





72
THE JOURNAL

OF

BIOLOGICAL CHEMISTRY

FOUNDED BY CHRISTIAN A. HERTER AND SUSTAINED IN PART BY THE CHRISTIAN A. HERTER
MEMORIAL FUND

EDITED BY

H. D. DAKIN, New York, N. Y. LAFAYETTE B. MENDEL, New Haven, Conn.
E. K. DUNHAM, New York, N. Y. A. N. RICHARDS, Philadelphia, Pa.
DONALD D. VAN SLYKE, New York, N. Y.

WITH THE COLLABORATION OF

J. J. ABEL, Baltimore, Md. P. A. LEVENE, New York, N. Y.
STANLEY R. BENEDICT, New York, N. Y. JACQUES LOEB, New York, N. Y.
R. H. CHITTENDEN, New Haven, Conn. A. S. LOEVENHART, Madison, Wis.
OTTO FOLIN, Boston, Mass. GRAHAM LUSK, New York, N. Y.
WILLIAM J. GIES, New York, N. Y. E. V. McCOLLUM, Baltimore, Md.
L. J. EENDERSON, Cambridge, Mass. A. B. MACALLUM, Toronto, Canada.
REID HUNT, Boston, Mass. J. J. R. MACLEOD, Cleveland, Ohio.
ANDREW HUNTER, Toronto, Canada. JOHN A. MANDEL, New York, N. Y.
W. A. JACOBS, New York, N. Y. A. P. MATHEWS, Chicago, Ill.
WALTER JONES, Baltimore, Md. F. G. NOVY, Ann Arbor, Mich.

THOMAS B. OSBORNE, New Haven, Conn.
T. BRAILSFORD ROBERTSON, Adelaide, Australia.
P. A. SHAFFER, St. Louis, Mo.
A. E. TAYLOR, Philadelphia, Pa.
F. P. UNDERHILL, New Haven, Conn.
V. C. VAUGHAN, Ann Arbor, Mich.
ALFRED J. WAKEMAN, New Haven, Conn.

VOLUME XL
BALTIMORE
1919

155-35-9
21/6/20

QP

501

577

v. 40 Δ 41

cop. 2

D.M
T

COPYRIGHT 1919
BY
THE JOURNAL OF BIOLOGICAL CHEMISTRY

PUBLISHED BY THE ROCKEFELLER INSTITUTE FOR MEDICAL RESEARCH FOR THE
JOURNAL OF BIOLOGICAL CHEMISTRY, INC.

WAVERLY PRESS
WILLIAMS & WILKINS COMPANY
BALTIMORE, U. S. A.

2
P
1/2

CONTENTS OF VOLUME XL.

No. 1, November, 1919.

LEVENE, P. A., and ROLF, IDA P., Cephalin. VII. The glycerophosphoric acid of cephalin.....	1
SHERWIN, CARL P., and HELFAND, MAX. Comparative metabolism of certain aromatic acids. III. Fate of <i>p</i> -nitrophenylacetic acid in the organism of fowl, dog, and man.....	17
BUELL, MARY V. Studies of blood regeneration. I. Effect of hemorrhage on alkaline reserve.....	29
BUELL, MARY V. Studies of blood regeneration. II. Effect of hemorrhage on nitrogen metabolism.....	63
ATKINSON, H. V., and LUSK, GRAHAM. Animal calorimetry. Sixteenth paper. The influence of lactic acid upon metabolism....	79
LEWIS, HOWARD B. The antiscorbatic value of the banana.....	91
VAN SLYKE, DONALD D., and SALVESEN, HARALD A. The determination of carbon monoxide in blood.....	103
SALVESEN, HARALD A. The determination of blood volume by the carbon monoxide method.....	109
BODANSKY, MEYER. A note on the determination of catalase in blood.	127
DOWELL, C. T., and MENAUL, PAUL. The action of furfurol and dextrose on amino-acids and protein hydrolsates.....	131
SOMMER, H. H., and HART, E. B. The heat coagulation of milk.....	137
KLEINER, ISRAEL S. The action of intravenous injections of pancreas emulsions in experimental diabetes.....	153
LEVENE, P. A. Crystalline guanylic acid.....	171
IKEGUCHI, TAKEO. A new sterol.....	175
ALLEN, E. R., and DAVISSON, B. S. On the relative accuracy of colorimetric and titrimetric procedures for determining nitrogen as ammonia.....	183
GAMBLE, JAMES L., and GOLDSCHMIDT, SAMUEL. A study of creatinuria in infants. I. Relation of creatinuria to acidosis. The elimination of ingested creatine and creatinine.....	199
GAMBLE, JAMES L., and GOLDSCHMIDT, SAMUEL. A study of creatinuria in infants. II. Relation of protein intake to urinary creatine....	215
HARDING, VICTOR JOHN, and YOUNG, ELRID G. Placental feeding and purine metabolism.....	227

No. 2, December, 1919.

MCCLENDON, J. F., COLE, W. C. C., ENGSTRAND, O., and MIDDLEKAUFF, J. E. The effects of malt and malt extracts on scurvy and the alkaline reserve of the blood.....	243
SHERWIN, CARL P., and KENNARD, K. SELLERS. Toxicity of phenylacetic acid.....	259
KENDALL, E. C., and OSTERBERG, A. E. The chemical identification of thyroxin. Second paper.....	265
VAN SLYKE, LUCIUS L., and BAKER, JOHN C. Carbonic acid and carbonates in cow's milk.....	335
VAN SLYKE, LUCIUS L., and BAKER, JOHN C. Conditions causing variation in the reaction of freshly-drawn milk.....	345
BAKER, JOHN C., and VAN SLYKE, LUCIUS L. A method for the preliminary detection of abnormal milk based on the hydrogen ion concentration.....	357
BAKER, JOHN C., and VAN SLYKE, LUCIUS L. A method for the determination of the keeping quality of milk.....	373
OSBORNE, THOMAS B., and WAKEMAN, ALFRED J. Extraction and concentration of the water-soluble vitamine from brewers' yeast.	383
LEVENE, P. A. Crystalline salts of uridinphosphoric acid.....	395
MITCHELL, H. H. On the identity of the water-soluble growth-promoting vitamine and the antineuritic vitamine.....	399
LEVENE, P. A. The structure of yeast nucleic acid. IV. Ammonia hydrolysis.....	415
MILLS, C. A. The activity of lung extract, as compared to extracts of other tissues, in inducing coagulation of the blood.....	425
JONES, D. BREESE, and JOHNS, CARL O. The hydrolysis of stizolobin, the globulin of the Chinese velvet bean, <i>Stizolobium niveum</i>	435
SUGIURA, KANEMATSU, and BENEDICT, STANLEY R. The nutritive value of the banana. II.....	449
MEIGS, EDWARD B., BLATHERWICK, N. R., and CARY, C. A. Further contributions to the physiology of phosphorus and calcium metabolism of dairy cows.....	469
STEENBOCK, H., and GROSS, E. G. Fat-soluble vitamine. II. The fat-soluble vitamine content of roots, together with some observations on their water-soluble vitamine content. Plate 1.....	501
RAIZISS, GEORGE W., KOLMER, JOHN A., and GAVRON, JOSEPH L. Chemotherapeutic studies on organic compounds containing mercury and arsenic.....	533
Index to Volume XL.....	553

CEPHALIN.

VII. THE GLYCEROPHOSPHORIC ACID OF CEPHALIN.

BY P. A. LEVENE AND IDA P. ROLF.

(From the Laboratories of The Rockefeller Institute for Medical Research.)

(Received for publication, August 2, 1919.)

The generally accepted structural formula of cephalin is as follows:

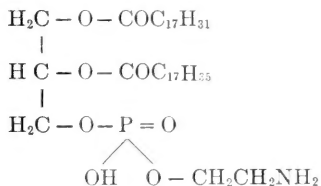

This conception presumes the existence of glycerophosphoric acid in the molecule of cephalin. Thudichum,¹ who discovered cephalin, also was the first to make this assumption. Every other worker who followed Thudichum made similar assumptions. Parnas² was the first to call attention to the lack of evidence in favor of the theory, though admitting the possibility of its correctness. MacLean in his monograph on "Lecithin and allied substances" presents a very lucid summary of the weak points of the theory.

The main objection to the conclusions of the older writers lies in the fact that the material employed by them was not a pure cephalin but a mixture of this substance with lecithin.

In recent years, Fränkel and Dimitz³ claimed to have identified glycerophosphoric acid as a component of cephalin. Unfortunately the evidence presented by these investigators is not con-

¹ Thudichum, J. L. W., *The chemical constitution of the brain*, London, 1884.

² Parnas, J., *Biochem. Z.*, 1909, xxii, 411.

³ Fränkel, S., and Dimitz, L., *Biochem. Z.*, 1909, xxi, 337.

vincing since they have failed to substantiate their claim with satisfactory analytical data. The analytical data are limited to one element; namely, barium.

Regardless of the meager proof of the nature of their substance, Fränkel and Dimitz have laid claim to a second very important discovery; namely, that the glycerophosphoric acid derived from cephalin was the optical isomer of the corresponding substance occurring in lecithin.

Willstätter and Lüdecke⁴ found that the glycerophosphoric acid obtained from lecithin was optically active and levorotary. The substance obtained by Fränkel and Dimitz was dextrorotary, and hence followed the claim that it was isomeric to the substance described by Willstätter and Lüdecke.

The presence of glycerophosphoric acid in the cephalin molecule seemed *a priori* quite probable in the light of facts discovered in recent years. Simultaneously, Foster⁵ and Levene and West⁶ have shown that glycerol is present in cephalin in the quantity required by the generally accepted theory.

Furthermore, it was found that the basic part of cephalin is amino ethyl alcohol, and that in this base the alcoholic group only is substituted, the amino group remaining free.

Theoretically there are only two alternative ways in which glycerol may be attached to the phosphoric acid, either directly (forming glycerophosphoric acid) or indirectly. If the linking were indirect, then the glycerol would be attached to the aminoethanol. If that were so, then the amino group could not be free in the molecule of cephalin. Thus the presence of glycerophosphoric acid in cephalin could have been accepted even before the substance was actually isolated, although for the final proof, the isolation of the substance would have been desirable. On the other hand, without isolating the substance there was no way to reach a decision as to which of the possible isomers of glycerophosphoric acid is the one present in the molecule of cephalin. True, the optical rotation of hydrolecithin and of hydrocephalin is practically identical in direction and magnitude. Levene and West⁷ have pointed out that this fact may be

⁴ Willstätter, R., and Lüdecke, K., *Ber. chem. Ges.*, 1904, xxxvii, 3753.

⁵ Foster, M. L., *J. Biol. Chem.*, 1915, xx, 403.

⁶ Levene, P. A., and West, C. J., *J. Biol. Chem.*, 1916, xxiv, 50.

⁷ Levene, P. A., and West, C. J., *J. Biol. Chem.*, 1918, xxxv, 287.

interpreted to signify that the glycerophosphoric acids in the two substances are identical. This conclusion contradicts the theory of Fränkel and Dimitz. Hence it became necessary to choose between the two views, and, in order to make the choice intelligently, an effort was made to isolate the glycerophosphoric acid of the cephalin molecule.

Glycerophosphoric Acid from Lecithin.

The present communication contains a report on the preparation of glycerophosphoric acid from both cephalin and lecithin. The latter was prepared for the following reasons. First, Willstätter and Lüdecke⁴ stated that the magnitude of the optical rotation of the glycerophosphoric acid from lecithin differed depending on the mode of preparation. Second, the directions for the preparation of the substances given by these authors are so meager that any one repeating the work could have no assurance that he was following exactly the conditions of Willstätter and Lüdecke. Under such circumstances if the glycerophosphoric acid prepared by us from cephalin was found different from the one of Willstätter and Lüdecke, the difference could have been ascribed not to the inherent properties of the substance, but to the manner of its preparation.

The glycerophosphoric acid obtained by us from lecithin resembled the one obtained by Willstätter and Lüdecke, in respect to the direction of its rotation. It was levorotary. However, the magnitude of the rotation of our substance was lower than the maximum rotation found by the earlier workers. The differences are probably due to differences in handling, since all the samples were partially racemized.

The maximum rotation found by us was $[\alpha]_D^{20} = -0.74$, by the other writers $[\alpha]_D^{20} = -1.71$.

In a general way the crude substance was prepared in the manner indicated by Willstätter and Lüdecke. However, for purification it was found convenient to convert the barium salt into the lead salt, to purify the lead salt, and then to reconvert this into the barium salt.

As a rule, the hydrolysis was brought about at room temperature; however, for the sake of comparison one experiment was

performed by boiling the hydrolysis mixture. This variation in the condition of hydrolysis remained without influence on the rotatory power of the resulting substance.

Hydrolysis of Cephalin.

After the most favorable conditions of hydrolysis of lecithin had been established, they were applied to the hydrolysis of cephalin. The result was practically identical. The glycerophosphoric acid obtained from cephalin, purified through conversion of the crude barium salt into the lead salt with subsequent reconversion of the latter into the barium salt, possessed the optical rotation of the same magnitude as the acid from lecithin; namely, $[\alpha]_D^{20} = -0.69$.

In this respect the result obtained by us is new. It establishes the fact that glycerophosphoric acid enters into the structure of cephalin, and further that the acid is identical with that present in lecithin. However, it is worthy of note that while the crude barium glycerophosphate obtained from lecithin always showed a levorotation, though of a comparatively low magnitude, the barium glycerophosphate from cephalin showed dextrorotation. The magnitude of this rotation was progressively descending on purification of the substance. All the dextrorotary samples were found to contain nitrogen, and the purification of the substance which led to the fall of the dextrorotation also led to the diminution in the nitrogen content. It is probable, therefore, that the claim of Fränkel and Dimitz to the discovery of a dextrorotary glycerophosphoric acid from cephalin was an error brought about by the fact that the substance analyzed by them was a mixture of glycerophosphoric acid with some product of intermediary hydrolysis.

EXPERIMENTAL.

Barium Glycerophosphoric Acid from Lecithin.

Hydrolysis at Low Temperature.

75 gm. of lecithin were obtained by the decomposition with ammonium carbonate of lecithin cadmium chloride containing 20 per cent amino nitrogen. This material was ground under water until a uniform emulsion was obtained, and then shaken

for 6 hours at room temperature with 1 liter of a saturated aqueous solution of barium hydroxide (the equivalent of $2\frac{1}{4}$ mols of $\text{Ba}(\text{OH})_2$). After standing for 3 hours, the mixture was filtered and the excess of barium contained in the filtrate removed quantitatively with sulfuric acid. The resulting filtrate was concentrated to a small bulk under diminished pressure, and the barium salt precipitated by pouring the thin syrup into several volumes of absolute alcohol. After one purification by dissolving in a small quantity of water, filtering through bone-black, and reprecipitating with alcohol, the yield of this material was 7.5 gm.

The barium salt obtained in this way was subjected to two more purifications by solution in water and precipitation by alcohol. Finally it was twice dissolved in a minimum amount of water and allowed to stand until it separated as a mass of heavy granules and non-crystalline scales. These were filtered with suction, washed with alcohol, and dried under diminished pressure. Obtained in this manner, the salt, when dry, is a light tan, granular material, which dissolves in water giving a clear yellow solution. Though very soluble in cold water it is not hygroscopic; on warming the cold solution a fine amorphous powder is precipitated which does not dissolve completely as the solution is cooled. It is insoluble in alcohol, ether, and acetone. All rotations were made in 20 per cent aqueous solution. A sample (No. 23) had the following composition. It contained no nitrogen.

0.1018 gm. of substance dried under diminished pressure at the temperature of zylene vapor gave on combustion 0.0472 gm. of CO_2 , 0.0248 gm. of H_2O , and 0.0712 gm. of ash.

0.2000 gm. of substance containing 7.36 per cent moisture gave 0.0666 mg. of $\text{Mg}_2\text{P}_2\text{O}_7$.

0.1000 gm. of substance containing 7.36 per cent moisture gave 0.0668 mg. of BaSO_4 .

	Calculated for $\text{C}_3\text{H}_7\text{O}_8\text{PBa}$.	Found. No. 23.
	<i>per cent</i>	<i>per cent</i>
C.....	11.71	12.64
H.....	2.29	2.72
P.....	10.10	10.02
Ba.....	44.68	42.43

The rotation of the substance was as follows:

$$[\alpha]_D^{20} = \frac{-0.075 \times 100}{1 \times 18.42} = -0.41.$$

As our investigation progressed, we found that the method of reprecipitation described above was not effective for the complete purification of the salts, as shown by their continued retention of nitrogen, and the process described below was applied to all our later products.

2 gm. of substance (No. 23) were dissolved in water. A 25 per cent aqueous solution of neutral lead acetate was added until precipitation was complete; the precipitate was filtered and thoroughly washed with water, alcohol, and ether. The lead salt thus isolated was suspended in water, and hydrogen sulfide passed through until the decomposition was complete. The lead sulfide was removed by filtration and the filtrate concentrated under diminished pressure to a small volume and made slightly alkaline to litmus with barium hydroxide. From the concentrated solution the barium salt was precipitated by adding several volumes of 95 per cent alcohol. The yield of this preparation, No. 63, was 1.5 gm.

When rapidly precipitated by alcohol, the barium salt separates in white amorphous flakes, which dry to a gleaming white powder. The color reported in the foregoing experiment is apparently due to an impurity as all samples obtained analytically pure were white when dry, and very readily soluble in water, giving colorless, water-clear solutions. If the salt after filtration is not dried either by washing with alcohol and ether or by rapid desiccation, the amorphous flakes undergo an apparent fusion and dry to a mass of colorless granules and scales. This granular form can also be obtained by precipitating the salt from a very concentrated aqueous solution by a gradual addition of alcohol.

0.101 gm. of substance dried under diminished pressure at temperature of xylene vapor gave on combustion 0.0438 gm. of CO_2 , 0.0194 gm. of H_2O , and 0.0742 gm. of ash.

0.2786 gm. of substance containing 9.11 per cent water gave 0.0912 gm. of $\text{Mg}_2\text{P}_2\text{O}_7$.

	Calculated for C ₃ H ₇ O ₆ PBa.	Found. No. 63.
	<i>per cent</i>	<i>per cent</i>
C.....	11.71	11.84
H.....	2.29	2.15
P.....	10.10	10.00
Ba.....	44.68	44.03

The rotation of No. 63 is

$$[\alpha]_D^{20} = \frac{-0.11 \times 100}{1 \times 18.82} = -0.58.$$

Both granular and flocculent forms after air-drying contain water of crystallization, the value of which is not constant, though in general it approaches $1\frac{3}{4}$ mols of H₂O. The nature of the substance, however, does not permit one to attribute too much importance to this value. After preliminary drying under diminished pressure over sulfuric acid at room temperature, the loss of water on complete drying was more constant, corresponding to C₃H₇O₆PBa·H₂O.

After air-drying, on desiccation over sulfuric acid under diminished pressure at the temperature of xylene vapor, 0.1108 gm. of No. 63 lost 0.0098 gm. of H₂O.

	Calculated for C ₃ H ₇ O ₆ PBa·1 $\frac{3}{4}$ H ₂ O.	Found. No. 63.
	<i>per cent</i>	<i>per cent</i>
H ₂ O	9.30	8.84

The substance was dried for 24 to 48 hours under diminished pressure over sulfuric acid at room temperature. On further drying to constant weight at the temperature of xylene vapor, 0.1100 gm. of No. 56 lost 0.0060 gm. of H₂O and 0.1092 gm. of No. 57 lost 0.0058 gm. of H₂O.

	Calculated for C ₃ H ₇ O ₆ PBa·H ₂ O.	Found.	
	<i>per cent</i>	No. 56. <i>per cent</i>	No. 57. <i>per cent</i>
H ₂ O.....	5.53	5.45	5.31

In order to be certain of the source of the glycerophosphoric acid, lecithin cadmium chloride was isolated from egg oil by the method recommended by Levene and West⁸ for the preparation of pure lecithin. The amino content of this material was negligible. From its cadmium salt the lecithin was isolated by treatment with (NH₄)₂CO₃ in boiling 85 per cent alcoholic solution.

⁸ Levene, P. A., and West, C. J., *J. Biol. Chem.*, 1918, xxxiv, 175.

75 gm. of this product were hydrolyzed with 1 liter of barium hydroxide solution, and the barium salt was isolated in the same manner as No. 23. 8 gm. of crude material were obtained from which the material most insoluble in alcohol was separated by repeated solution in water and fractional precipitation with small volumes of alcohol. After eighteen such reprecipitations, a substance (No. 55) of the following composition and analysis was obtained. It contained no nitrogen.

0.200 gm. of substance containing 5.03 per cent moisture gave 0.0706 gm. of $Mg_2P_2O_7$.

0.100 gm. of substance containing 5.03 per cent moisture gave 0.0690 gm. of $BaSO_4$.

	Calculated for $C_3H_7O_6PBa$.	Found. No. 55.
	<i>per cent</i>	<i>per cent</i>
N.....	0.00	0.00
P.....	10.10	10.36
Ba.....	44.68	42.75

$$[\alpha]_D^{20} = \frac{-0.12 \times 100}{1 \times 18.89} = -0.63.$$

That a longer period of hydrolysis would give a better yield and not affect the rotation adversely seemed probable, and was proved by hydrolyzing 100 gm. of lecithin for 16 hours with 1,350 cc. of a saturated barium hydroxide solution. When isolated by the method described for No. 23 the yield of the crude material was 35 gm. (90 per cent of the theory). After three precipitations from alcohol this material (No. 56) had the following composition.

0.200 gm. of substance containing 5.45 per cent moisture gave 0.0572 gm. of $Mg_2P_2O_7$.

0.100 gm. of substance containing 5.45 per cent moisture gave 0.0664 gm. of $BaSO_4$.

0.200 gm. of substance containing 5.45 per cent moisture used for Kjeldahl nitrogen determination required 0.26 cc. of 0.1 N HCl.

	Calculated for $C_3H_7O_6PBa$.	Found. No. 56.
	<i>per cent</i>	<i>per cent</i>
N.....	0.00	0.18
P.....	10.10	8.43
Ba.....	44.68	41.33

No. 56 was then further purified by precipitating the lead salt and decomposing this by the directions given above. The

resulting substance (No. 57) had the following composition and rotation. It contained no nitrogen.

0.200 gm. of substance containing 5.31 per cent moisture gave 0.0704 gm. of $Mg_2P_2O_7$.

0.100 gm. of substance containing 5.31 per cent moisture gave 0.0680 gm. of $BaSO_4$.

	Calculated for $C_3H_4O_6PBa$. <i>per cent</i>	Found. No. 57. <i>per cent</i>
N.....	0.00	0.00
P.....	10.10	10.38
Ba.....	44.68	42.26

$$[\alpha]_D^{20} = \frac{-0.09 \times 100}{1 \times 19.36} = -0.46.$$

A second purification through the lead salt resulted in No. 60, whose rotation was

$$[\alpha]_D^{20} = \frac{-0.14 \times 100}{1 \times 18.92} = -0.74.$$

A third purification by this method gave no further change in the rotation.

The final analysis after an additional precipitation with alcohol follows.

0.1026 gm. of substance dried *in vacuo* at temperature of xylene vapor gave on combustion 0.0482 gm. of CO_2 , 0.0248 gm. of H_2O , and 0.0774 gm. of ash.

0.200 gm. of substance containing 7.06 per cent moisture gave 0.0696 gm. of $Mg_2P_2O_7$.

	Calculated for $C_3H_4O_6PBa$. <i>per cent</i>	Found. No. 78. <i>per cent</i>
C.....	11.71	12.81
H.....	2.29	2.70
P.....	10.10	10.43
Ba.....	44.68	44.87

Hydrolysis at Higher Temperature.

97 gm. of lecithin cadmium chloride were dissolved in 250 cc. of boiling 50 per cent alcohol and this solution was added to one containing 103 gm. ($3\frac{1}{4}$ mols) of barium hydroxide in 1 liter of hot water. After 1 hour of gentle boiling the mixture was cooled and filtered. The excess of barium hydroxide was removed

from the filtrate by quantitative precipitation with sulfuric acid, and the filtered solution concentrated in vacuum to small bulk. The addition of an equal volume of 95 per cent alcohol precipitated the salt of glycerophosphoric acid, but the barium chloride formed in the course of the hydrolysis remained in solution. Thorough washing with 50 per cent alcohol removed all traces of chlorides from the filtered barium glycerophosphoric acid. After two preliminary precipitations by alcohol, the salt was converted into the lead salt, decomposed, and again reprecipitated as the barium salt by the directions given above.

The specific rotation of this substance was

$$[\alpha]_D^{20} = \frac{-0.03 \times 100}{1 \times 18.89} = -0.16.$$

A second purification by conversion into the lead salt raised this rotation as follows:

$$[\alpha]_D^{20} = \frac{-0.12 \times 100}{1 \times 18.89} = -0.63.$$

On analysis 0.102 gm. (No. 69), dried under diminished pressure over sulfuric acid at temperature of xylene vapor, gave on combustion 0.0234 gm. of H₂O, 0.0449 gm. of CO₂, and 0.0724 gm. of ash.

0.300 gm. (No. 69), containing 7.77 per cent moisture, gave 0.1021 gm. of Mg₂P₂O₇.

	Calculated for C ₃ H ₇ O ₆ PBa. <i>per cent</i>	Found. No. 69. <i>per cent</i>
C.....	11.71	12.00
H.....	2.29	2.56
P.....	10.10	10.28
Ba.....	44.68	41.19

Barium Glycerophosphoric Acid from Cephalin.

Preparation of Cephalin.

Three samples of cephalin were used as the source of the glycerophosphoric salts described below. All were obtained from ox brains by six extractions with ether containing 5 per cent water. This material, after evaporation of the ether, was precipitated with acetone and the fats and saturated phosphatides were removed from the precipitate by repeatedly dissolving in ether,

removing all material insoluble in ether at 0°, and reprecipitating by pouring into acetone. From the mixture of lecithin and cephalin thus obtained, the cephalin was separated by precipitating the ethereal solution with alcohol. The first sample of cephalin was purified by repeated precipitation by alcohol from ethereal solution and finally three precipitations from a solution in gasoline (B. P. 50–60°). The analysis of this material (No. 44) is given below.

The second sample, after three precipitations from an ethereal solution by alcohol, was shaken with water until a uniform emulsion was obtained. From this the cephalin was precipitated by dilute hydrochloric acid, separated by centrifuging, and thoroughly washed with acetone. Further purification was effected by repeatedly dissolving either in ether (saturated with water at room temperature) or in gasoline (B. P. 50–60°) and precipitating with alcohol. This material (No. 58) had the composition indicated below.

The third sample was prepared in the following manner. The crude cephalin was exhaustively extracted with alcohol at room temperature and then repeatedly reprecipitated by alcohol from ether or gasoline solution, until its amino content was that indicated in the analysis (No. 135) recorded below. Following this the material was emulsified with water, precipitated by hydrochloric acid, and the precipitate washed with alcohol.

No. 44.

0.5 gm. was dissolved in 5 cc. of glacial acetic acid.

2 cc. of this solution for Kjeldahl determination required 340 cc. of 0.1 N HCl = 0.00468 gm. of N.

2 cc. of this solution for Van Slyke determination gave 8.55 cc. of N at $T^{\circ} = 26^{\circ}\text{C}$. and $P = 757.1$ mm.; $N = 0.00476$ gm.

$$\text{Ratio } \frac{\text{NH}_2\text{N}}{\text{Total N}} = \frac{1}{1}$$

No. 58.

2 gm. of cephalin were hydrolyzed with HCl, neutralized, and concentrated to 25 cc.

5 cc. of this solution required for Kjeldahl determination 0.90 cc. of 0.1 N HCl = 0.00126 gm. of N.

2 cc. of this solution by Van Slyke determination gave 0.91 cc. of N at $T^{\circ} = 24^{\circ}$ and $P = 755.9$ mm.; $N = 0.000505$ gm.

$$\text{Ratio } \frac{\text{NH}_2\text{N}}{\text{Total N}} = \frac{1}{1}$$

No. 135.

0.2 gm. was dissolved in 10 cc. of glacial acetic acid.

5 cc. of this solution for Kjeldahl determination required 1.27 cc. of 0.1 N HCl = 0.001778 gm. of N.

1 cc. of this solution for Van Slyke determination gave 0.65 cc. of N at $T^\circ = 30^\circ$ and $P = 759.2$ mm.; $N = 0.003505$ gm.

$$\text{Ratio } \frac{\text{NH}_2\text{N}}{\text{Total N}} = \frac{1}{1}$$

Hydrolysis of Cephalin.

75 gm. of cephalin (No. 44) were hydrolyzed by shaking for 9 hours at room temperature with a liter of saturated barium hydroxide solution. The directions given for No. 23 were followed in working up the resulting mixture. On pouring the concentrated aqueous solution into alcohol a colloidal solution formed which was precipitated by the addition of a few cc. of an aqueous solution of barium acetate. After thirteen reprecipitations by alcohol from its aqueous solution, this material (No. 51) had the following composition and rotation.

0.200 gm. of substance containing 5.67 per cent moisture gave 0.0556 gm. of $\text{Mg}_2\text{P}_2\text{O}_7$.

0.100 gm. of substance containing 5.67 per cent moisture gave 0.0662 gm. of BaSO_4 .

0.200 gm. of substance used for Kjeldahl determination required 1.12 cc. of 0.1 N HCl.

	Calculated for $\text{C}_2\text{H}_7\text{O}_6\text{PBa}$.	Found. No. 51.
	<i>per cent</i>	<i>per cent</i>
N.....	0.00	0.83
P.....	10.10	8.21
Ba.....	44.68	41.28

$$[\alpha]_D^{20} = \frac{+0.15 \times 100}{1 \times 18.88} = +0.80.$$

No. 51 five times reprecipitated by alcohol still retained nitrogen.

0.200 gm. of substance (No. 53) containing 9.28 per cent moisture required for Kjeldahl determination 0.77 cc. of 0.1 N HCl.

	Calculated for C ₃ H ₇ O ₆ PBa. <i>per cent</i>	Found. No. 53. <i>per cent</i>
N.....	0.00	0.59

Its rotation was

$$[\alpha]_D^{20} = \frac{+0.08 \times 100}{1 \times 18.20} = +0.44.$$

Ten additional reprecipitations by alcohol gave a substance (No. 59) of the following composition and rotation.

0.200 gm. of substance containing 9.07 per cent moisture gave 0.0566 gm. of Mg₂P₂O₇.

0.100 gm. of substance containing 9.07 per cent moisture gave 0.0644 gm. of BaSO₄.

0.200 gm. of substance containing 9.07 per cent moisture used for Kjeldahl determination required 0.57 cc. of 0.1 N HCl.

	Calculated for C ₃ H ₇ O ₆ PBa. <i>per cent</i>	Found. No. 59. <i>per cent</i>
N.....	0.00	0.40
P.....	10.10	8.67
Ba.....	44.68	41.68

$$[\alpha]_D^{20} = \frac{+0.04 \times 100}{1 \times 18.19} = +0.22.$$

All these salts agreed in property and appearance with the salts derived from the hydrolysis of lecithin by the same sort of purification. They all retained a distinctly yellow color which could not be wholly removed by bone-blackening the aqueous solution. All specimens were very soluble in water and rotations were made on 20 per cent aqueous solutions.

The mother liquors from the purifications of No. 51 and its derivatives were concentrated in vacuum to a small bulk and precipitated with alcohol. The bulky precipitate was filtered and again dissolved in water. To this was added a 25 per cent aqueous solution of neutral lead acetate, and on standing lead glycerophosphoric acid settled out. This salt was filtered, suspended in water, and decomposed by hydrogen sulfide. The precipitated lead sulfide was filtered and the filtrate concentrated to a small bulk. The barium salt of glycerophosphoric acid was again isolated by adding barium hydroxide until slightly alkaline to litmus and precipitating with several volumes of alcohol. This

material was a glistening white, amorphous powder, identical in all characteristics with No. 63 obtained in an analogous manner from lecithin. Its composition and rotation were as follows. It contained no nitrogen.

0.1594 gm. of substance containing 5.56 per cent moisture gave 0.0548 gm. of $Mg_2P_2O_7$.

0.103 gm. of substance containing 5.56 per cent moisture gave 0.0752 gm. of $BaSO_4$.

	Calculated for $C_5H_7O_6PBa$. per cent	Found. No. 64. per cent
P.....	10.10	10.14
Ba.....	44.68	45.48

$$[\alpha]_D^{20} = \frac{-0.13 \times 100}{1 \times 18.97} = -0.69.$$

Another hydrolysis of cephalin was made on 75 gm. of cephalin (No. 58) which were shaken for 16 hours at room temperature with $2\frac{1}{4}$ mols of barium hydroxide. The barium glycerophosphoric acid was isolated by the method used in the previous experiments, and after a preliminary precipitation with alcohol, was purified by conversion to the lead salt, and reprecipitation as the barium salt, according to the directions given under the foregoing experiment. After two additional precipitations by alcohol from its aqueous solution, the yield of this material (No. 68) was 5 gm. and its composition and rotation were the following.

0.101 gm. of substance dried under diminished pressure over sulfuric acid at temperature of xylene vapor yielded on combustion 0.0520 gm. of CO_2 , 0.0218 gm. of H_2O , and 0.0684 gm. of ash.

0.200 gm. of substance containing 7.84 per cent moisture gave 0.0626 gm. of $Mg_2P_2O_7$.

	Calculated for $C_5H_7O_6PBa$. per cent	Found. No. 68. per cent
C.....	11.77	14.04
H.....	2.29	2.41
P.....	10.10	9.92
Ba.....	44.68	39.12

$$[\alpha]_D^{20} = \frac{-0.9 \times 100}{1 \times 18.40} = -0.49.$$

A second purification through the lead salt and one reprecipitation from alcohol gave a substance (No. 77) of the following composition and rotation.

0.099 gm. of substance dried under diminished pressure over sulfuric acid in xylene bath gave on combustion 0.0484 gm. of Mg_2CO_3 , 0.0222 gm. of H_2O , and 0.0692 gm. of ash.

0.300 gm. of substance containing 9.00 per cent moisture gave 0.0956 gm. of $Mg_2P_2O_7$.

	Calculated for $C_3H_7O_6PBa$. per cent	Found. No. 77. per cent
C.....	11.71	13.33
H.....	2.29	2.50
P.....	10.10	9.76
Ba.....	44.68	41.36

$$[\alpha]_D^{20} = \frac{-0.12 \times 100}{1 \times 18.00} = -0.67.$$

A third hydrolysis of cephalin was carried out in the same way on 50 gm. of cephalin (No. 135) and the purification of this material was exactly like that giving rise to No. 77. The analysis and rotation of this material were as follows:

0.1011 gm. of substance dried under diminished pressure over sulfuric acid in xylene bath, gave on combustion 0.044 gm. of CO_2 , 0.0216 gm. of H_2O , and 0.0724 gm. of ash.

0.200 gm. of substance containing 8.80 per cent moisture gave 0.0648 gm. of $Mg_2P_2O_7$.

	Calculated for $C_3H_7O_6PBa$. per cent	Found. No. 145. per cent
C.....	11.71	11.86
H.....	2.29	2.40
P.....	10.10	9.89
Ba.....	44.68	43.88

$$[\alpha]_D^{20} = \frac{-0.13 \times 100}{1 \times 20.05} = -0.65$$

Like the barium glycerophosphates obtained from lecithin, these salts, after air-drying, contained variable amounts of water of crystallization approaching $1\frac{3}{4}$ mols; while after desiccation under diminished pressure for about 24 hours at room temperature, a more constant content of water was retained, corresponding to $C_3H_7O_6PBa \cdot H_2O$.

On complete desiccation over H_2SO_4 under diminished pressure at the temperature of xylene vapor, the following results were obtained.

0.1256 gm. of No. 59, previously air-dried, lost 0.0114 gm. of H_2O .
 0.1088 " " " 77, " " " 0.0098 " " H_2O .
 0.1101 " " " 78, " " " 0.0093 " " H_2O .

	Calculated for $\text{C}_3\text{H}_7\text{O}_6\text{PBa}\cdot\frac{1}{2}\text{H}_2\text{O}$.	No. 59.	Found. No. 77.	No. 78.
	<i>per cent</i>	<i>per cent</i>	<i>per cent</i>	<i>per cent</i>
H_2O	9.30	9.07	9.00	9.29

The substance dried at room temperature under diminished pressure lost on drying to constant weight at the temperature of xylene vapor as follows:

0.1164 gm. of No. 51 lost 0.0066 gm. of H_2O .
 0.1116 " " " 64 " 0.0062 " " H_2O .

	Calculated for $\text{C}_3\text{H}_7\text{O}_6\text{PBa}\cdot\text{H}_2\text{O}$.	Found. No. 51.	No. 64.
	<i>per cent</i>	<i>per cent</i>	<i>per cent</i>
H_2O	5.53	5.67	5.56

COMPARATIVE METABOLISM OF CERTAIN AROMATIC ACIDS.

III. FATE OF P-NITROPHENYLACETIC ACID IN THE ORGANISM OF FOWL, DOG, AND MAN.

BY CARL P. SHERWIN AND MAX HELFAND.

(From the Laboratory of Fordham University Medical School, New York City.)

(Received for publication, August 25, 1919.) †

Many organic substances have been fed to animals to determine the process by which the animal body will dispose of them. If non-toxic, they may be wholly or at least in part oxidized and utilized for heat production. If toxic, such compounds must be detoxicated and eliminated as rapidly as possible. In the latter case we are able to study with a certain degree of precision what might be called the non-specific defense mechanism of the body.

We have already studied the method employed by the body when certain putrefactive compounds derived from phenylalanine and tyrosine are detoxicated and eliminated in the urine. Oxidation and reduction play a large part in this process of detoxication, but often a point is reached where β -oxidation of the side chain is no longer possible, and in this case conjugation seems to be the method most often employed by the animal body. Thus benzoic acid no longer subject to oxidation in the organism is coupled with glycocholic acid and eliminated in the urine as hippuric acid. Again, phenylacetic acid, which results from the action of bacteria on phenylalanine, cannot be oxidized by the tissues but is detoxicated by combining it with one of the shorter amino-acids. In this case the formation of the phenylacetic acid in the body of man and the lower animals seems to be the same type of reaction, but the process of detoxication is apparently more complicated in the animal than that taking place in the human body.

After feeding phenylacetic acid to animals such as dogs (1), rabbits (2), and monkeys (3), the acid appears in the urine com-

bined with glycocholic acid, as phenaceturic acid; when ingested by human beings (4), phenylacetic acid is excreted in the urine in combination with glutamine, as phenylacetylglutamine. It has also been shown (5) that there is a difference in the processes of detoxication employed by man and animals after the feeding of *p*-hydroxybenzoic acid and *p*-hydroxyphenylacetic acid.

In the literature, one finds little concerning the metabolism of nitro compounds and particularly aromatic nitro derivatives. Sieber and Smirnow (6) fed large doses of *p*-nitrobenzaldehyde to a dog and recovered small amounts of *p*-nitrohippuric acid urea from the dog's urine. Cohn (7) fed *p*-nitrobenzaldehyde to rabbits and isolated from their urine a compound made up of *p*-nitrobenzoic acid and *p*-acetylamino benzoic acid. Jaffe (8) fed "large amounts" (30 gm.) of *p*-nitrotoluene to a dog. He recovered some of the substance unchanged from the feces, some from the urine as *p*-nitrobenzoic acid, but most of it he found was eliminated in the urine as *p*-nitrohippuric acid urea. Bertagnini (9) ingested small quantities of nitrobenzoic acid at frequent intervals, thus ingesting in all 80 gm. during a period of several days. He was unable to prove the presence of either nitrobenzoic or nitrohippuric acid in the urine, but extracted from the urine an oily substance which gave nitrobenzoic acid and glycocholic acid on hydrolysis.

As there seemed to be no definite information in the literature regarding the fate of either the nitrobenzoic acids or nitrophenylacetic acids in the human body we decided to undertake some feeding experiments which eventually included not only man but the dog and fowl also. The compound used in these experiments was in each case *p*-nitrophenylacetic acid.

As oxidation of the side chain of phenylacetic acid seems impossible for either the animal or human body, there were several changes which this compound might undergo when ingested by a person. It seemed most probable that the nitro group should remain untouched and that a combination with glutamine or glycocholic acid should be formed, and perhaps urea should also be added to the *p*-nitrophenylacetylglutamine or *p*-nitrophenaceturic acid thus formed. On the other hand, a reduction of the nitro group was not impossible with a secondary acetylation of the amino group.

In the case of the dog it seemed most probable that *p*-nitrophenacetic acid or *p*-nitrophenacetic acid urea would be formed and eliminated in the urine.

The fowl seems to furnish, in most cases, large quantities of ornithine for the detoxication of foreign substances instead of glycocoll. Thus after feeding benzoic acid to chickens Jaffe (10) isolated from the urine a substance composed of 1 mol of ornithine and 2 mols of benzoic acid which he called ornithuric acid. Totani (11) after feeding phenylacetic acid to hens recovered a substance from the urine which he termed phenacetornithuric acid, and which was analogous to the compound isolated by Jaffe as it consisted of 2 mols of phenylacetic acid and 1 mol of ornithine.

Fate of p-Nitrophenylacetic Acid in the Human Organism.

The subject was a student of 70 kilos body weight and apparently in the best of health. The acid, being insoluble in water, could not be taken in the form of solution nor in capsules on account of bulk. A dose of 5 gm. of acid in crystalline form was accurately weighed out, taken into the mouth, and washed down with copious quantities of water. The acid possesses a very disagreeable taste not unlike pepper, with an after taste not unlike that of the copper salts.

The urine was collected for 48 hours after each dose of the acid, each collection was carefully neutralized with sodium carbonate as soon as voided, then the entire amount slowly evaporated on a water bath at low temperature. The urine when evaporated to a thick syrup was cooled below room temperature and acidified with H_3PO_4 until it showed an acid reaction with Congo red. This concentrated urine was placed in a continuous extracting apparatus and extracted for 5 hour periods with ether. The different ether extracts were placed in the ice box for a number of days to allow the formation of crystals. As no crystals appeared, the ether extracts were evaporated somewhat each day, then placed on ice over night. During this time no crystals appeared, so all the ether extracts were united and allowed to evaporate slowly at room temperature. As dryness was reached, only a yellow oil appeared and no crystalline substance. This

20 Metabolism of *p*-Nitrophenylacetic Acid

oily residue was dissolved in hot water, boiled with charcoal, filtered, and then allowed to cool. After a short time long yellow needles appeared in the solution and later the solution took on the form of a crystalline mass. The crystals were removed by suction and recrystallized several times from hot water. Dried at 80° they melted at 150–151.5°. The melting point as well as the crystalline form showed the substance to be *p*-nitrophenylacetic acid which had been eliminated in the urine unchanged.

Analysis.—0.1533 gm. of the substance required 8.60 cc. of 0.1 N sulfuric acid (Kjeldahl).

	Calculated for C ₈ H ₇ N O ₄ per cent	Found. per cent
N.....	7.74	7.84

Only *p*-nitrophenylacetic acid crystallized out of the water solution of the ether extract, so it was evaporated to a small volume and repeatedly extracted with ether to remove the last traces of *p*-nitrophenylacetic acid. Enough concentrated sulfuric acid was added to this water solution to produce a 30 per cent acid solution and the solution boiled under a reflux condenser for several hours. The acid solution was cooled and repeatedly extracted with ether to remove any *p*-nitrophenylacetic acid which might be present. The ether extracts were united, evaporated to dryness, and the residue dissolved in hot water. No trace of *p*-nitrophenylacetic acid appeared at any stage in this extract so it seemed that no compound of *p*-nitrophenylacetic acid had been extracted from the urine by the ether.

It seemed reasonable to expect a compound of *p*-nitrophenylacetic acid with either glycocoll or glutamine so the evaporated urine was again extracted repeatedly with alcohol. As *p*-nitrophenylacetic acid is quite insoluble in cold alcohol this substance should have crystallized out of the alcohol if present, but no crystals appeared. The alcoholic extracts were united and evaporated, but only large amounts of urea and some hippuric acid crystals appeared. The alcoholic extract was evaporated to dryness and dissolved in hot water, and the water solution acidified with sulfuric acid and boiled under a reflux condenser for several hours. This acid solution was cooled and extracted with ether but again no *p*-nitrophenylacetic acid was found. It appeared that no compound of *p*-nitrophenylacetic acid had been extracted

from the urine by the alcohol. The urine was further extracted with ethyl acetate and lastly with benzene following the same method as employed in the alcohol extraction, but no trace of the acid could be found. As a last resort a part of the evaporated urine was diluted with enough water to bring it into solution and strongly acidified with sulfuric acid. After boiling this for several hours it was cooled and extracted with ether to determine the amount of *p*-nitrophenylacetic acid which might have been split off from any compound existing in the urine. Again none of the acid appeared, so there certainly could have been no compound in the urine containing *p*-nitrophenylacetic acid.

After two 5 gm. doses of the acid had been ingested, a total of 6.87 gm. (68.70 per cent) of *p*-nitrophenylacetic acid was recovered from the urine as the uncombined acid.

It seems peculiar that this acid should be found free in the urine. While perhaps less toxic than phenylacetic acid, still some symptoms of intoxication such as nausea, headache, and diarrhea were experienced by the subject. It is certainly more irritating to the mucous membranes than benzoic acid, and benzoic acid taken in corresponding doses is almost quantitatively converted into hippuric acid.

Fate of p-Nitrophenylacetic Acid in the Organism of the Dog.

A dog of 32.70 kilos body weight was fed three doses of *p*-nitrophenylacetic acid. The acid crystals were pulverized and packed into large gelatin capsules. The capsules were inserted into large chunks of cooked meat which were thrown to the dog and swallowed without mastication. The first dose of the acid consisted of 5 gm.; a second dose of 5 gm. was fed 1 week later, followed by a third dose of 7 gm. 2 days later.

The dog was kept in a large metabolism cage and the urine collected for 48 hours after each dose of the acid. The different portions of urine collected during this time were united and evaporated to a thick syrup, acidified with H_2SO_4 , and extracted with ether for several hours in a continuous extracting apparatus. All portions of the ether used in this extraction were united and the ether was distilled off. The residue was dissolved in cold absolute ether, filtered, and the filtrate allowed to evaporate at room temperature. As no crystals appeared until the point of dryness was reached, the residue was redissolved in hot water,

boiled with charcoal, and allowed to stand in the ice box for 24 hours. Long yellow needles appeared in the solution and finally became almost a solid mass. The crystals were removed by suction and recrystallized from hot water. Dried at 80–90°, the crystals melted at 150–151.5°. The melting point as well as the characteristic solubility and crystalline structure of the substance showed it to be *p*-nitrophenylacetic acid which had been excreted in the urine unchanged. After a dose of 5 gm., 1.53 gm. of the acid were recovered from the urine while, after a dose of 5 gm. followed after 48 hours by a dose of 7 gm., 5.32 gm. of the *p*-nitrophenylacetic acid were isolated from the dog's urine.

The evaporated urine was removed from the ether-extracting apparatus and placed in a large separatory funnel. It was then extracted several times with large volumes of hot alcohol. The alcoholic extracts were united and slowly evaporated to dryness. The residue was dissolved in hot water, boiled with charcoal, and filtered. The filtrate was slowly evaporated by stages until crystals appeared on cooling. This substance which seemed quite insoluble in water was thus easily separated from urea, hippuric acid, and other alcohol-soluble urinary constituents. Recrystallized from hot water, the substance formed extremely long hair-like needles. When dry, the substance melted at 172–173°. The melting point, as well as the solubility and crystalline form of the substance, showed it to be identical with the *p*-nitrophenaceturic acid prepared synthetically by Hotter (12).

0.2761 gm. of substance required 11.45 cc. of 0.1 *N* NaOH for neutralization.

Calculated for $C_{10}H_{10}N_2O_5$: required 11.60 cc. of 0.1 *N* NaOH.

2 gm. of the substance were boiled for 2 hours with 30 per cent HCl, cooled, and the acid solution was extracted several times with ether. The ether extracts were evaporated to dryness and the residue was dissolved in hot water and boiled with charcoal. After filtering, the filtrate was allowed to stand for some hours and crystals of *p*-nitrophenylacetic acid appeared. These crystals when dried melted at 150–151°. The amount of *p*-nitrophenaceturic acid isolated from the urine after a 5 gm. dose of *p*-nitrophenylacetic acid was 0.757 gm., while after a dose of 5 gm. followed by 7 gm. of the acid, 2.873 gm. of *p*-nitrophenaceturic acid were recovered.

The fate of *p*-nitrophenylacetic acid in the organism of the dog is similar to that of its homologue *p*-nitrobenzoic acid.

The *p*-nitrotoluene fed to dogs (8) was first converted into *p*-nitrobenzoic acid, followed by a secondary reaction in which most of this substance was converted into *p*-nitrohippuric acid urea. The greater part of the *p*-nitrophenylacetic acid was excreted in the urine uncombined while a part of it was conjugated with glycocholic acid and excreted as *p*-nitrophenylacetic acid. None of the latter compound, however, was found in combination with urea. After feeding 5 gm. of the *p*-nitrophenylacetic acid, 1.53 gm. (30.60 per cent) were excreted in the urine unchanged, while only 0.757 gm. (15.14 per cent) was excreted as the glycocholic acid compound. Thus a total of only 2.287 gm. (45.64 per cent) of the substance were recovered from the urine. After feeding 5 gm. followed by 7 gm. of the substance, 5.32 gm. (44.35 per cent) were isolated from the urine as the free acid and 2.873 gm. were obtained from the urine as the glycocholic acid compound (*p*-nitrophenylacetic acid). Therefore after a total of 12 gm. had been fed, 61.47 per cent of the substance was recovered.

Fate of p-Nitrophenylacetic Acid in the Organism of the Fowl.

For this work a hen of 2.18 kilos body weight was selected. The acid was administered by means of a funnel and soft rubber tube. In this case a solution of the sodium salt was used and washed down with large quantities of water. The dose in each case amounted to 1 gm. of the acid. The substance proved quite toxic, as the hen refused to eat for some days after the first dose and showed marked signs of depression. The hen was kept in a metabolism cage and all excreta saved for 48 hours after each dose. The excreta, which were always very hard and dry, were stirred into a paste after the addition of sufficient amounts of water. To this mass dilute sulfuric acid was added until the reaction was strongly acid to Congo red. It was then immediately extracted with ethyl acetate alcohol (10:1) mixture in a continuous extracting apparatus. The first and second extracts were evaporated to one-fifth the original volume *in vacuo* at 40°, then placed on ice for 48 hours. This process was repeated until the extracts became very concentrated but no crystals appeared. After complete evaporation, there remained a black tar-like mass. This substance seemed to be entirely insoluble in cold water but

slightly soluble in hot water. On cooling the hot water solution, it became a milky emulsion and under the microscope was found to contain fine droplets of an oil-like substance held in suspension. On cooling to room temperature the liquid became clear with a light yellow, oily deposit on the sides of the receptacle. There appeared to be two different substances present, one an oil-like substance and a second black gum-like substance which was unaffected by water. The water was poured off and both substances were dried at 40°. The mixture was extracted for 12 hours with ether in a continuous extracting apparatus. Most of the black gummy substance remained in the extracting apparatus but changed in color to a dull gray. The yellow substance dissolved easily in ether. The ether extract was filtered and allowed to evaporate at room temperature, leaving a yellow crystalline deposit. This crystalline mass was dissolved in hot water and slowly cooled. Long yellow crystals appeared in the water solution. The crystals were removed and dried at 80°. The melting point was between 149-150°, so the substance was apparently *p*-nitrophenylacetic acid.

0.2018 gm. of the substance required 11.10 cc. of 0.1 N sulfuric acid (Kjeldahl).

	Calculated for C ₈ H ₇ N O ₄ per cent	Found, per cent
N	7.74	7.70

The residue from the ether extract was dissolved in warm alcohol and allowed to cool; as no crystals appeared, ether was added until the solution became turbid. The flask was tightly stoppered and placed in the ice box for 24 hours. A fine deposit of microscopic crystals was found on the bottom of the flask so these were filtered off and more ether was added. By repeating this process, enough of the material was gathered for further work. This substance appeared to be insoluble in water but easily soluble in alkaline solutions. The substance was dissolved in barium hydroxide and the excess of barium removed by passing CO₂ through the solution and filtering off the barium carbonate. The filtrate containing the barium salt of the substance was evaporated by stages to one-third its original volume. After standing in the ice box for several days, large leaf-like crystals appeared on the surface of the liquid and formed a solid crust. The potassium and sodium

salts of the acid were formed from the barium salt by adding a solution of sodium and potassium sulfate to the solution of the barium salt. These salts were found to be too hygroscopic for analysis. The water solutions of all the salts formed were found to be dextrorotatory.

To prepare the pure substance a solution of the barium salt was acidified with H_2SO_4 and extracted with alcohol. The alcohol solution was concentrated and a few drops of ether were added until the solution became turbid. After standing for several days in the ice box, short, thick, irregular needles appeared in the solution. These were recrystallized from an alcohol ether mixture and dried *in vacuo*. The dried substance melted at $184-185^\circ$.

The analysis gave the following results.

0.1321 gm. of the substance gave 0.2662 gm. of CO_2 and 0.0576 gm. of H_2O .

0.2371 gm. of the substance required 20.80 cc. of 0.1 N sulfuric acid (Kjeldahl).

Calculated for $C_{21} H_{22} N_4 O_8$: C = 54.99 per cent, H = 4.84 per cent, N = 12.22 per cent.

Found. C = 54.95 per cent, H = 4.99 per cent, and N = 12.30 per cent.

0.1191 gm. of the substance required 2.70 cc. of 0.1 N sodium hydroxide for neutralization. Calculated for $C_{21} H_{22} N_4 O_8$: 2.60 cc. of 0.1 N NaOH were required.

A weighed amount of the substance was boiled for 3 hours with a 30 per cent solution of HCl, cooled, and extracted with ether. The ether extracts were evaporated to dryness and the residue recrystallized from hot water. The resulting yellow crystals when dried melted at $148.5-150^\circ$.

0.1007 gm. of the substance required 5.45 cc. of 0.1 N sulfuric acid (Kjeldahl).

Calculated for $C_8 H_7 NO_3$: N = 7.74 per cent.

Found. N = 7.58 per cent.

This substance was *p*-nitrophenylacetic acid. The acid solution remaining after the ether extraction was evaporated *in vacuo* to drive off the excess of HCl. The residue was dissolved in a small amount of water and made alkaline with sodium carbonate. To this alkaline solution benzoyl chloride was added in small amounts at frequent intervals. During the entire period the solution was kept alkaline, shaken vigorously after each addition of benzoyl

chloride, and cooled as often as necessary. After 45 minutes the solution was removed from the separatory funnel and acidified with HCl. The acidified solution was extracted several times with ether to remove all benzoic acid formed. After standing for some time a mass of leaf-like crystals appeared. These crystals were washed chlorine-free and dissolved in warm alcohol. By cooling the solution leaf-like crystals of ornithuric acid appeared. The substance was pure ornithuric acid as was shown by the melting point of 184–185° and by the following analysis.

0.1262 gm. of the substance required 7.55 cc. of 0.1 N sulfuric acid (Kjeldahl).

0.1136 gm. of the substance gave 0.2801 gm. of CO₂ and 0.0624 gm. of H₂O.

Calculated for C₁₉ H₂₀ N₂ O₄: C = 67.02 per cent, H = 5.92 per cent, and N = 8.23 per cent.

Found. C = 67.23 per cent, H = 6.13 per cent, and N = 8.37 per cent.

This compound was identical with the ornithuric acid prepared by Jaffe (13), thus proving ornithine as the other constituent of the compound isolated from the excreta of the hen.

This compound must consist of 1 mol of ornithine and 2 mols of *p*-nitrophenylacetic acid and therefore has the following formula.

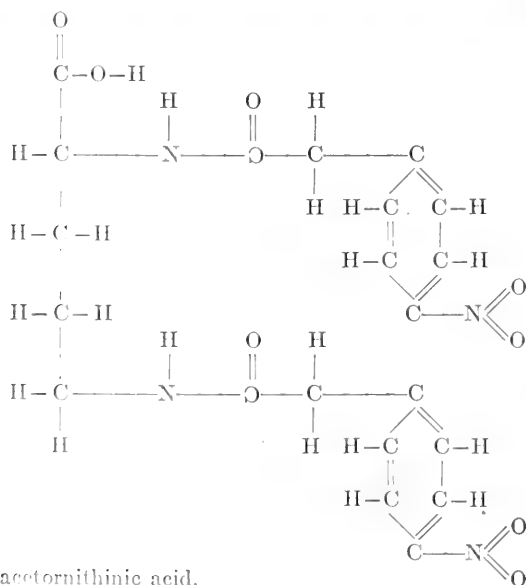

The combination of *p*-nitrophenylacetic acid with ornithine is quite in line with the results obtained by other investigators in experiments where fowls were used. In this case as in the experiments performed on the human being and on the dog no reduction or alteration of the nitro group was found in any case, as was reported by Cohn (7) after feeding rabbits *p*-nitrobenzaldehyde.

CONCLUSION.

1. *p*-Nitrophenylacetic acid was ingested by a man in 5 gm. doses. 68.70 per cent of the acid was recovered from the urine in an uncombined state. No compound of the acid was found in the urine.

2. *p*-Nitrophenylacetic acid was fed to a dog in 5 and 7 gm. doses. 61.47 per cent of the acid was isolated from the urine. Of this amount 44.35 per cent was in the uncombined state while 17.12 per cent was combined with glycocholic acid and excreted as *p*-nitrophenaceturic acid.

3. *p*-Nitrophenylacetic acid was fed to a hen in 1 gm. doses. Some of the acid was excreted uncombined but the greater portion was conjugated with ornithine, and excreted as *p*-nitrophenacet-ornithinic acid. This acid which had not been previously prepared was isolated, analyzed, and its structure determined. The barium, potassium, and sodium salts of the compound were prepared and found to be dextrorotatory.

BIBLIOGRAPHY.

1. Salkowski, E., and Salkowski, H., *Ber. chem. Ges.*, 1879, xii, 653.
2. Salkowski, E., and Salkowski, H., *Z. physiol. Chem.*, 1882-83, vii, 161.
3. Sherwin, C. P., *J. Biol. Chem.*, 1917, xxxi, 307.
4. Thierfelder, H., and Sherwin, C. P., *Ber. chem. Ges.*, 1915, xlvii, 2630; *Z. physiol. Chem.*, 1915, xciv, 1
5. Sherwin, C. P., *J. Biol. Chem.*, 1918, xxxvi, 309.
6. Sieber, N., and Smirnow, A., *Monatsh. Chem.*, 1887, viii, 88.
7. Cohn, R., *Z. physiol. Chem.*, 1893, xvii, 295.
8. Jaffe, M., *Ber. chem. Ges.*, 1874, vii, 1673.
9. Bertagnini, C., *Ann. Chem.*, 1851, lxxviii, 100.
10. Jaffe, M., *Ber. chem. Ges.*, 1877, x, 1925.
11. Totani, G., *Z. physiol. Chem.*, 1910, lxxviii, 75.
12. Hotter, E., *J. prakt. Chem.*, 1888, xxxviii, 110.
13. Jaffe, M., *Ber. chem. Ges.*, 1878, xi, 406.

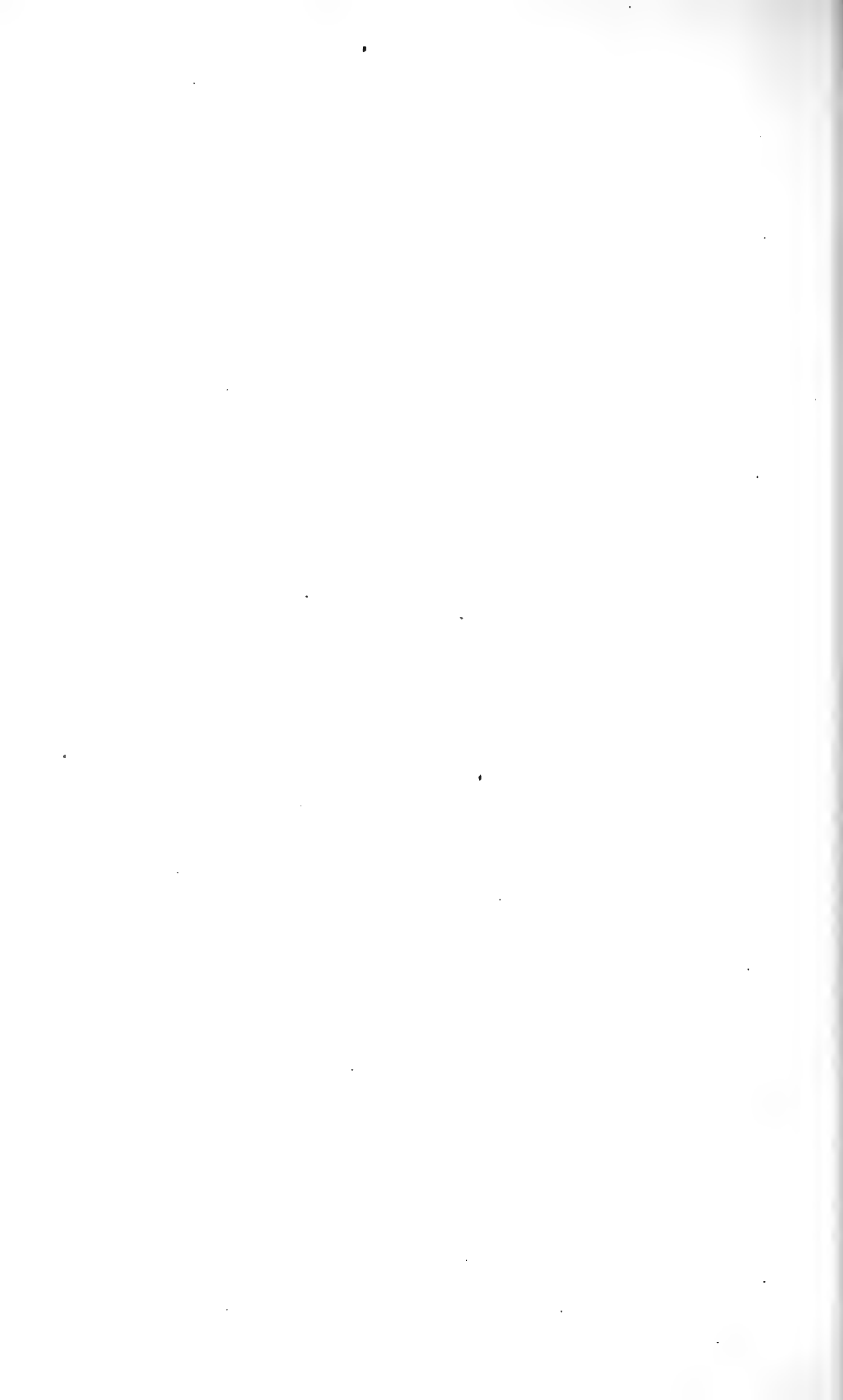

STUDIES OF BLOOD REGENERATION.*

I. EFFECT OF HEMORRHAGE ON ALKALINE RESERVE.

BY MARY V. BUELL.

(From the Department of Agricultural Chemistry, University of Wisconsin, Madison.)

(Received for publication, August 11, 1919.)

INTRODUCTION.

With the exception of Milroy's¹ work, no systematic attempt has been made, as far as the writer has been able to ascertain, to follow chemically the changes in alkaline reserve during the period immediately following hemorrhage. Since the Van Slyke² method has been devised, such a study has been greatly facilitated. Not only can more extensive data be obtained by the use of this method, due to its simplicity, but also the results so obtained have greater significance due to the fact that changes can be detected too small to influence the hydrogen ion concentration which Milroy determined.

The hemorrhages which Milroy¹ studied with cats and dogs were large (approximately one-third the total volume of blood). In all cases he found a distinct rise in the hydrogen ion concentration of the plasma, determined by the gas chain method; *i.e.*, a loss of reserve alkali. This change was most apparent in the cases in which the plasma was subjected to high concentrations of CO₂. Samples of blood drawn at intervals of 15 and 45 minutes after hemorrhage showed these distinct changes in reaction. Milroy concluded that there must have been rapid compensatory passage of the tissue fluids into the circulation, the fluid which first entered the circulation being extremely poor in reserve alkali. The greatest increase in hydrogen ion concentration was found after the 15 minute interval.

* The work described in this article forms part of a thesis submitted in partial fulfilment of the requirements for the degree of Doctor of Philosophy in the University of Wisconsin.

¹ Milroy, T. H., *J. Physiol.*, 1917, li, 259.

² Van Slyke, D. D., *J. Biol. Chem.*, 1917, xxx, 347.

Since hemorrhage uncomplicated by other conditions such as shock and anesthesia is rarely encountered clinically many studies of these conditions are closely interwoven. Cannon and his co-workers³ have studied clinically many cases of primary and secondary wound shock, hemorrhage, etc., with and without other complications, in a casualty clearing station near the front line trenches in France. In the uncomplicated hemorrhage cases, an examination of the blood disclosed lowered alkaline reserve. In cases of acidosis and low blood pressure due to shock, hemorrhage, or infection with the gas bacillus, the pulse was rapid, but did not vary with the degree of acidosis. As the acidosis became more extreme, the respiratory rate increased, fatal cases showing true "air hunger" before death. As regards the relative reduction in alkaline reserve by the conditions of shock, hemorrhage, and infection with gas bacillus, Cannon's figures indicate the probability that uncomplicated hemorrhage is not followed by so great a reduction of alkaline reserve as is shock and infection with gas bacillus when the blood pressures are equally reduced.

Penfield⁴ observed that acidosis developed gradually when the blood pressures of etherized dogs were brought to a low level by progressive hemorrhage, about 100 per cent of the total blood volume (calculated as 5 per cent of body weight) being removed. After varying lengths of time, the pressure was raised by infusion of different solutions. With one exception, death occurred only in those animals whose alkaline reserve was low.

Morriss⁵ studied the effect of ether anesthesia on the alkaline reserve, using Van Slyke's method. He found a reduction in the reserve alkali in every case, but this reduction was not dependent upon the duration of ether anesthesia or upon the extent of the operation. He also found that the alkaline reserve might decrease notably when the patient lost relatively little blood, and on the other hand, might not change greatly when conspicuous hemorrhage occurred. He concluded that a notable drop might occur in the carbon dioxide-combining power of the plasma during the first half hour of anesthesia.

³ Cannon, W. B., Fraser, J., and Hooper, A. N., *J. Am. Med. Assn.*, 1918, lxx, 526. Cannon, W. B., *ibid.*, 531.

⁴ Penfield, W. G., *Am. J. Physiol.*, 1919, xlviii, 121.

⁵ Morriss, W. H., *J. Am. Med. Assn.*, 1917, lxxviii, 1391.

The Reaction Regulator Mechanism.

Dependent upon the proper hydrogen ion concentration of the blood are such vital processes as the control of the respiratory and vasomotor centers, enzyme action, the swelling of colloids, and cellular oxidation. Fortunately the organism has a protective mechanism which guards against the acids which are constantly formed in the animal organism by the normal metabolism of its tissue and the foods ingested. This mechanism may be regarded as consisting of several factors; first, the function of the buffer salts; second, the ability of the organism to excrete the weak acids (carbonic and phosphoric acids) set free by stronger acids; and third, the ability of the organism to produce ammonia at the expense of urea.

Van Slyke's method for the determination of alkaline reserve is based upon the principle that the power of the organism to protect itself against the encroachment of acids is proportional to the bicarbonate content of the arterial blood. In actual practice Van Slyke analyzes the plasma obtained from centrifugation of venous blood and reports the "alkaline reserve" in terms of volumes per cent of carbon dioxide chemically bound by 100 cc. of plasma. The possibility that HCl may pass from plasma to cells or *vice versa*, depending on the CO₂ tension, makes the precaution necessary that the blood should always be at definite CO₂ tension when centrifuged, as well as when analyzed. Van Slyke² and Austin and Jonas⁶ carefully studied the effect on alkaline reserve of variations in the technique used in collecting the blood, and preparing the plasma for analysis.

The immediate cause and opportunity for this investigation were furnished by the plant for making serum to be used in vaccination against hog cholera, which is operated in connection with the College of Agriculture of the University of Wisconsin. In this plant large numbers of pigs are hyperimmunized against hog cholera. The animals are subsequently bled, the blood is defibrinized, and the serum used commercially. In this process, a certain routine, found by experience to be satisfactory and economical, has been established. Approximately 10 days after the animals have been hyperimmunized they are subjected to

⁶ Austin, J. H., and Jonas, L., *Am. J. Med. Sc.*, 1917, cliii, 81.

tail bleeding, if they have not lost in weight. After an interval of 7 days the pig is subjected to a second tail bleeding if it has not lost in weight, and after 7 more days the pig is slaughtered.

EXPERIMENTAL.

In preliminary experiments, the blood was treated by what will hereafter be referred to in this paper as the "open vessel method" or Method I. The blood was allowed to flow directly from the tail into a small open Erlenmeyer flask which contained sufficient potassium oxalate to prevent clotting. Under the conditions of the experiment, the blood spurted rapidly from the artery directly into the flask, and so came into minimum contact with the tissues. No needle or other apparatus was required in collecting the sample. The flask was then rotated once or twice to insure the oxalate being dissolved in the blood, and was then carried to the laboratory for centrifugation with as little agitation as possible. The interval between collection and centrifugation was approximately $\frac{1}{2}$ hour.

Standardization of Methods.

In order to discover the effect of this treatment on the alkaline reserve value, the following experiments were performed. Animals were kept at the laboratory in cages, and samples of blood were collected and treated under different conditions. In the first instance a stream of blood was allowed to spurt directly from the tail artery into a paraffined Erlenmeyer flask containing a small amount of potassium oxalate. The blood was centrifuged and the plasma analyzed by means of Van Slyke's technique.

This "open vessel method," when the blood was centrifuged and the plasma analyzed immediately, was very nearly comparable with Van Slyke's routine technique when he used a McRae needle for collection. By the open vessel method, it is true, the blood necessarily falls twice for a short distance through the air. This fact would seem to double the possibility for loss of carbon dioxide. So much less agitation was necessary, however, to insure thorough mixing of the oxalate with the blood in a receptacle like an Erlenmeyer flask that it seemed preferable to make the collections in such a flask rather than in a centrifuge tube.

This was particularly true in cases where the blood clotted rapidly, as after repeated hemorrhage. Because of the necessity, when working with a pig, of taking the blood samples from a cut tail, it was impossible to collect samples by Van Slyke's paraffin oil method; *i.e.*, without loss of some carbon dioxide.

Open Vessel Method.—Bloods collected by the open vessel method in the presence of sufficient potassium oxalate to prevent clotting were treated as follows.

I-a-1.—The blood was poured directly into centrifuge tubes, centrifuged, and the plasma analyzed at once (Curve I, Fig. 1).

I-a-2.—The blood was centrifuged as described under *I-a-1*. The clear plasma was pipetted into a paraffined weighing bottle, preserved in a refrigerator for 48 hours, and was then analyzed (Curve II, Fig. 1).

I-b.—The blood was allowed to remain in the Erlenmeyer flask in which it was collected for $\frac{1}{2}$ hour. It was then centrifuged and the plasma analyzed immediately (Curve III, Fig. 1).

I-c.—The technique was the same as *I-b*, the time before centrifugation being extended to 2 hours (Curve IV, Fig. 1).

In the second instance an effort was made to approximate Van Slyke's paraffin oil method by allowing the blood to flow directly from the tail artery into a paraffined separatory funnel which had been previously filled with alveolar air. This technique was called the "separatory funnel method" or Method II. Duplicate collections of the blood analyzed by the open vessel method were made by the separatory funnel method and the samples so obtained were treated in various manners. Since the separatory funnel method was more laborious, and the results obtained were not duplicated so easily, this method proved to have no advantage over Method I, and was consequently abandoned. For the sake of brevity, the analyses by this method are not reported here.

Table I gives the results of the preliminary analyses. In all cases the figures represent the volumes per cent of CO₂ obtained from 1 cc. of plasma, and are the average of closely agreeing duplicates. After the first three series, all collections were made in paraffined vessels.

All the samples reported in the same vertical column of Table I were taken from the same animal, one sample immediately following another, and were then treated in the various manners described. The blood for the first five series of determinations was obtained from a female; for the second four series from a male.

Each weighed approximately 200 pounds. The extreme variations in the alkaline reserve values of the blood from the same animal on different days will be discussed in detail later.

The column headed "average difference" was computed as follows. The first method of determination (the open vessel method, centrifuged and analyzed immediately) was arbitrarily selected as the standard. If subsequent determinations were lower, the difference was indicated by a negative sign, and if

TABLE I.
Effect of Various Methods on Alkaline Reserve Values.

Method.	Alkaline reserve of blood from Fig 1.					Alkaline reserve of blood from Fig 2.				Average differ- ence.
	June 27.	June 27.	June 28.	July 2.	July 3.	July 5.	July 5.	July 6.	July 8.	
	a. m.	p. m.	a. m.	a. m.	a. m.	a. m.	p. m.	a. m.	a. m.	
I-a-1. Centrifuged and analyzed immediately.	49.4	56.7	25.8	53.1	58.4	51.3	29.1	48.3	54.0	±0
I-a-2. Centrifuged immediately; analyzed after 2 days.	46.4	53.5	29.5	52.8	59.0	50.8	27.9	48.4		-4.5
I-b. Centrifuged after $\frac{1}{2}$ hour; then analyzed at once.	36.7	48.8	27.7	51.9	56.5	49.7	27.2	45.0	52.6	-3.3
I-c. Centrifuged after 2 hours; then analyzed at once.		49.2	29.6	51.9	54.1	46.5	26.3	44.2	50.3	-3.1

higher, by a positive sign. It will be seen that the average fall in alkaline reserve after intervals of $\frac{1}{2}$ and 2 hours respectively is almost identical, and the maximum variation in the entire series between these two values is 3.2 volumes per cent.

The results obtained by the open vessel method are expressed graphically in Fig. 1. The alkaline reserve values are plotted on the vertical axis, and values in the same series (that is on the bloods collected at the same time, but subjected to different techniques) are given the same position on the horizontal axis.

Consequently, consistent results among the different techniques should yield parallel lines. That the lines to a certain extent approximate the parallel is an indication not only that the results can, within limits, be duplicated, but also that the time element is not an all-important factor. In other words, samples analyzed $\frac{1}{2}$ hour or 2 hours after collection may not give identical values with the same samples analyzed immediately, but at least, corresponding time intervals yield samples that are, within limits, comparable. There is not extreme variation between short intervals, as, for instance, the $\frac{1}{2}$ and 2 hour intervals.

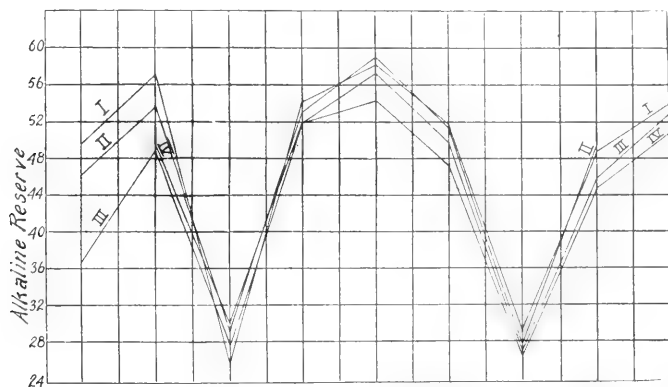

FIG. 1. Open vessel method. Illustrates the effect of different preliminary treatment on the alkaline reserve values of the same bloods. Alkaline reserve values are plotted on the ordinates and values obtained from the same collections, but analyzed by various techniques, are given the same position on the abscissæ. The general parallelism of the lines indicates that the results can be duplicated and that the various treatments yield consistent results.

Another attempt was made to find a technique which would be comparable with Van Slyke's method in which there was no loss of CO_2 during collection. Austin and Jonas⁶ found that when they brought the whole blood into equilibrium with alveolar air immediately before centrifugation, their results were slightly higher than results obtained by Van Slyke's method, but were consistent with them. Since the details of Austin and Jonas' procedure could not be found, the following procedure was adopted. This technique will subsequently be referred to as the "alveolar air method" or Method III.

The blood was allowed to flow directly from the tail blood vessels into a paraffined separatory funnel of 300 cc. capacity, into which sufficient potassium oxalate had been introduced to prevent clotting. The funnel was then turned upside down once or twice to insure the oxalate being mixed with the blood. Just before the blood was centrifuged, alveolar air was blown into the funnel, and the funnel was then rotated end over end at the rate of one complete revolution per second for 60 seconds. Alveolar air was again blown into the funnel, and the process was repeated. In all, three such aspirations were made. Theoretically, if the composition of the alveolar air in the funnel were 6 per cent CO_2 , then, during the three aspirations, 54 cc. of CO_2 , measured at the same temperature and pressure, would have been introduced. The average difference (as will be shown later) between simultaneous determinations by Methods I and III is approximately 10 volumes per cent, or 0.10 cc. of CO_2 for every 1.0 cc. of plasma. It is not known how much CO_2 is absorbed by the corpuscles under these conditions. Furthermore, a liquid and a gas are in equilibrium not when their percentage compositions are the same but when their partial pressures are equal; *i.e.*, when the pressure of the gas on the liquid is equal to the tendency of the gas to leave the surface of the liquid. Since the actual mass of CO_2 absorbed by the blood from the alveolar air was such a small proportion of the mass of CO_2 actually introduced, and since the alveolar air was introduced in three separate portions, and each time was allowed to come into intimate diffusion relations with the blood, it seemed highly probable that the blood had absorbed as much CO_2 as it could be made to hold under these conditions, and that this technique was comparable to that of Austin and Jonas in which they brought the blood into equilibrium with alveolar air before centrifuging. The whole blood was then drawn off from the separatory funnel into a centrifuge tube under paraffin oil and was centrifuged under a layer of the oil. A great many determinations of alkaline reserve were made from samples of blood which were simultaneously collected, centrifuged, and analyzed, one sample being treated in the manner described for Method I and another in the manner described for Method III. In Tables II, III, and IV and Figs. 2 to 8 will be found the records of the determinations so made. In some cases (Figs. 2,

3, and 4, and Table II) a definite effort was made to ascertain the effect on the alkaline reserve values of allowing the blood to stand varying lengths of time before being centrifuged. The object of this experiment was to standardize the methods which might be used in subsequent experiments. In this work it was not the absolute alkaline reserve values of the blood as it existed

TABLE II.

Effect of Time before Centrifugation on Alkaline Reserve Values by Various Methods.

Animal No.	Time after collection before centrifugation.	Alkaline reserve.		Temperature.	Remarks.
		Method I.	Method III.		
	<i>min.</i>			°C.	
3	70	54.3	60.5	32	See Fig. 2.
	70	53.7	59.6		
	185	51.7	55.6		
	185	50.1	56.9		
	360	50.6	53.5		
	360	50.1	53.5		
4	55	48.1	60.6	26	See Fig. 3.
	85	48.1	58.6		
	115	48.1	60.0		
	145	48.6	58.1		
	175	48.2	58.3		
	305	48.0	56.4		
5	75	26.7	41.4	22	See Fig. 4.
	105	26.4	40.9		
	135	26.2	39.7		
	165	25.9			
	195	26.7	25.9		

in the animal body which were sought, but the relative values before and after hemorrhage.

It was noticed early in the work that fairly constant differences existed between the values obtained by Methods I and III for different sets of samples collected and analyzed under the same conditions. For instance, on one day, the average difference of six sets of samples analyzed by Methods I and III was 4.9, the maximum variation from this average figure being ± 1.6 . On

another day, the average difference between the two methods run on the same number of samples was 8.2, the maximum variation from this figure being 1.9. Figs. 2 to 8 show that curves representing values obtained by the two methods for the most part run fairly parallel, each curve tending to afford evidence of the comparative accuracy of the data represented by the other. Furthermore, the curves plotted from data obtained by Method I are noticeably more regular, and hence are subject to fewer minor variations, than those plotted from data obtained by Method III. The degree of accuracy with which separate collections and centrifugations of samples could be duplicated by the two methods is indicated by the first series of data in Table II. An average of

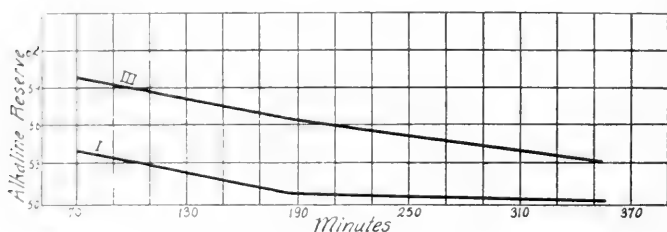

FIG. 2. On Curves I and III are plotted the alkaline reserve values obtained from samples collected at the same time, but allowed to stand definite periods of time before being centrifuged. Curve I represents values obtained by the open vessel method; Curve III, by the alveolar air method. Duplicate collections as well as duplicate analyses were made in each case, and average figures used. Temperature 32°C.

these duplicates was used in plotting Fig. 2. Although, as will be explained presently, Method III more nearly approaches an accurate picture of the true alkaline reserve values, results obtained by Method I are more easily duplicated, and apparently bear a more or less definite relation to the alkaline reserve values of the blood as it exists in the animal body.

A partial explanation for the variation in the relative values obtained by the two methods was found in the variation in temperature at the time when the samples were centrifuged. It happened that the data expressed in Fig. 2 were obtained on a summer day when the temperature was 32°C. The time in minutes after the samples were collected before they were centrifuged and

analyzed (or preserved in paraffined weighing bottles in an ice box) is plotted on the horizontal axis, the alkaline reserve values being plotted on the vertical axis. Although these data are very meager, they would seem to indicate that there was a small, though appreciable loss of CO_2 from the samples, even after the hour period, a point which was not illustrated in Fig. 1. To test further this possibility, two similar experiments were run, when the temperature was somewhat lower (Figs. 3 and 4). These results tend to uphold the conclusion that after the initial loss in CO_2 by a blood sample, which occurs during the first $\frac{1}{2}$ hour after the blood is drawn, there is very little subsequent loss during the following 2

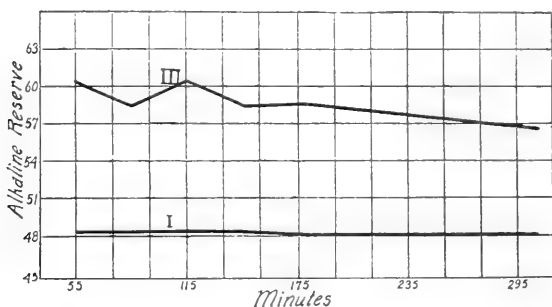

FIG. 3. Curve I represents alkaline reserve values obtained by the open vessel method on simultaneous collections which were allowed to stand varying lengths of time before centrifugation. Curve III represents values obtained on duplicate collections, treated by the alveolar air method. Temperature 26°C . In general, values obtained by Method III are higher than those obtained by Method I, but are consistent with them.

hours at ordinary temperatures; and that the values so obtained bear a more or less definite relation to those obtained when the blood is analyzed as soon as it is drawn. In only one case was a single value obtained which was entirely out of harmony with these ideas. This value is plotted at the last point in Curve III, Fig. 4. This plasma had been kept in an ice box for 4 days before it was analyzed. In general, the experience of the author entirely confirmed that of Van Slyke, inasmuch as plasma could be kept in an ice box for 7 days without appreciable loss in CO_2 content. The conclusion seems justifiable in this case that the plasma had undergone bacterial change or had become contaminated in some

other way. This contention is supported by another experiment. Two 15 cc. samples of blood (the alkaline reserve values of duplicate collections, by the open vessel method, were centrifuged and analyzed immediately, and were 53.8 and 58.4 respectively) were subjected for 15 minutes to the reduced pressure produced by a powerful vacuum pump. The blood was then centrifuged and analyzed, these values being 38.7 and 39.6 respectively. In these two cases, where the maximum loss of CO_2 might have been expected, the actual loss was 15.1 and 18.8 volumes per cent. Doubtless, then, the drop of 15.8 referred to above was not due to accidental loss of CO_2 .

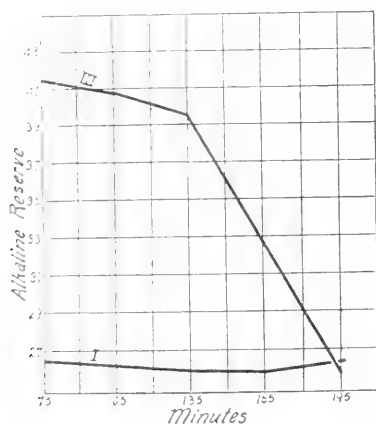

FIG. 4. Curve I represents values obtained by the open vessel method and Curve III by the alveolar air method, as in case of Figs. 2 and 3. Temperature 22°C . The plasma represented by the last point on Curve III had undoubtedly undergone bacterial change.

Although temperature is doubtless a contributing factor to the relative differences found in the analysis of duplicate samples by Methods I and III, examination of the curves indicates that, in general, larger differences were obtained when samples having comparatively high alkaline reserve values were analyzed. Fig. 8 illustrates this point. When the lowest values were reached at the 60 minute interval, the difference was 3 volumes per cent as compared with an initial difference of 15. If one had two solutions containing carbon dioxide in different proportions, and if one

manipulated these solutions in such a way that some carbon dioxide was lost, both solutions being treated in like manner, it seems reasonable to suppose that a larger mass of carbon dioxide would be lost by the solution containing the larger per cent of carbon dioxide. If one may reason by analogy, it seems logical that more carbon dioxide would be lost in the open vessel technique if the initial bicarbonate content were high than if it were low. Since loss of carbon dioxide is guarded against by Method III, greater differences between the two methods would be apparent when the initial bicarbonate content was comparatively high.

Influence of Hemorrhage on Alkaline Reserve.

The most surprising feature of the alkaline reserve values obtained in this preliminary work on methods was the fact that blood shed by the same animal varied tremendously on different days (Table I). The values recorded in the columns headed June 28 a.m. and July 5 p.m. were in each case obtained from the same animal as the values in the columns immediately preceding and following. The idea might be advanced that the drops in alkaline reserve were the result of loss of blood from a previous bleeding. This seems highly improbable, however, because in each bleeding in this series, not more than 100 cc. of blood were taken at a time. Furthermore, there was no relationship between the frequency of bleeding and the alkaline reserve values. As the experiment proceeded, it became evident that the high values were invariably associated with the bleedings which were accomplished without any struggle on the part of the animal before or at the time when the blood was drawn. The two extremely low values referred to were associated with violent struggling, and the intermediate values represented corresponding degrees of struggle. This point is further borne out by subsequent experiments. The data in Table III, which are taken from a series of tail bleedings, illustrate this point. In this table, a lower alkaline reserve value at the end of the bleeding is shown by a positive sign in the column headed "loss in alkaline reserve during bleeding," and *vice versa*. It is evident that, in those cases where little or no struggle took place during bleeding, the alkaline reserve values of the last 10 cc. of the large bleeding did not differ greatly from the values of the

first 10 cc. This fact is emphasized here in order that it may be borne in mind in connection with the data obtained in subsequent bleeding experiments.

In a preliminary experiment an attempt was made to follow the alkaline reserve values of a pig daily. Because of the difficulty in obtaining samples, and because the work of Milroy and others pointed to the fact that the drop in alkaline reserve caused by hemorrhage occurs soon after the blood is shed, no further attempts

TABLE III.

Typical Changes in Alkaline Reserve during the Process of Bleeding.

Animal No.	Weight.	Blood drawn.	Method.	Alkaline reserve.		Loss in alkaline reserve during bleeding.	Remarks.
				1st 10 cc. drawn.	Last 10 cc. drawn.		
21	289	1,400	I	47.3	43.9	+3.4	Quiet throughout; bled freely.
21	289	1,400	III	55.9	56.9	-1.0	
7	245	1,000	I	50.4	51.2	-0.8	Quiet throughout; bled slowly.
52	272	1,000	I	51.2	48.9	+2.3	Quiet throughout; bled slowly.
18	210	1,300	I	61.6	59.7	+1.9	Quiet throughout; bled freely.
18	210	1,300	III	69.2	68.1	+1.1	
6	291	1,400	I	45.1	29.1	+16.0	Quiet before bleeding; struggled violently during bleeding; bled freely.
6	291	1,400	III	54.5	36.1	+18.4	

were made to collect daily samples. The procedure subsequently adopted was as follows. The animal was confined in a crate, and the tail was shaved. A small portion of the tail was then cut off, and the first few cc. of blood (about 5 cc.) were discarded. When the blood spurted from the artery in a good stream, two small samples (about 10 cc. each) were collected for analysis by Methods I and III. The results from these samples in each case were plotted as the first points on the curves. The cut tail was introduced into the vacuum flask and sufficient blood was drawn

to approximate 6 cc. per pound of body weight. Two more small samples were then taken as before, and the time of sampling was noted. The intervals between the samples at the beginning and at the end of the large bleeding indicated the duration of bleeding. From these data the approximate rate of bleeding could be calculated. Since the rate of bleeding varied consider-

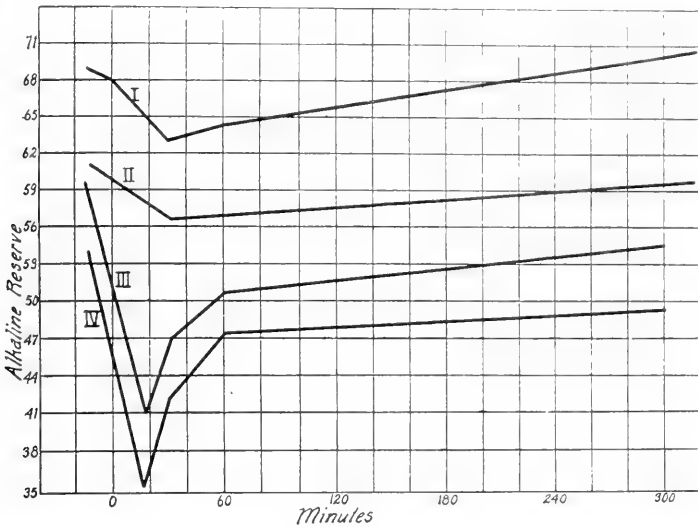

FIG. 5. Curve I (alveolar air method) and Curve II (open vessel method) illustrate the drop in alkaline reserve following the first hemorrhage of Sow 20. The time (abscissæ) is expressed in minutes before or after the large hemorrhage was completed; *i.e.*, the first point on the curves represents the alkaline reserve values of the first blood shed, the second point (at 0) the values of the last 10 cc. of the large bleeding. Curve III (alveolar air method) and Curve IV (open vessel method) represent a second hemorrhage of the same animal a week later (Table IV).

ably at different times, all subsequent samples were timed from the minute at which the large sample had been completely drawn. The animal was left in the crate, and the samples were taken at the intervals desired. Loss of blood between samples was prevented by tightly winding a rubber band around the end of the tail. At the end of the hour, the pig was taken from the crate, put into a pen, and was not disturbed until another sample was

TABLE IV.
Effect of Hemorrhage on Alkaline Reserve.

Animal No.	Description.	Weight.	Blood drawn.	Dose, cc.	Time of sampling.	Alkaline reserve.		Remarks.
						I.	III.	
20	Not hyper-immune, ♀	210	1,260		First 10 cc. of big bleeding.	61.6	69.2	Bleeding lasted 8 min.; very quiet throughout; no difficulty with respiration. (Fig. 5.)
					Last 10 " " "	59.7	68.1	
					30 min. after end of "	56.5	63.8	
					60 " " " "	57.4	64.9	
20 (7 days later.)	Not hyper-immune, ♀	234	1,400		317 " " " "	60.6	70.7	Struggled just when samples were taken at end of big bleeding; struggled considerably during first 1/2 hr. after bleeding; restless during second 1/2 hr.; respiration normal throughout; necessary to cut the tail again to collect the last sample; bleeding lasted 14 min. (Fig. 5.)
					First 10 cc. of big bleeding.	54.3	60.5	
					Last 10 " " "	46.6	50.8	
					15 min. after end of "	35.3	41.0	
21	Hyper-immune, ♀	299	1,333		30 " " " "	42.3	47.0	Bleeding lasted 8 min.; struggled when samples were taken; otherwise quiet throughout; respiration normal. (Fig. 6.)
					60 " " " "	47.6	50.9	
					300 " " " "	49.5	55.1	
					First 10 cc. of big bleeding.		53.0	
22	Hyper-immune, ♀	202	1,260		Last 10 " " "	37.9	47.0	Bleeding lasted 23 min.; poor bleeder; tail was cut 3 times during big bleeding; fairly quiet throughout, except when the last samples were taken. (Fig. 7.)
					15 min. after end of "	33.7	44.5	
					30 " " " "	30.9	37.7	
					60 " " " "	31.0	39.0	
					First 10 cc. of big bleeding.	48.1	60.6	
					Last 10 " " "	41.9	51.2	
					15 min. after end of "	41.9	50.7	
					30 " " " "	43.0	49.5	
					60 " " " "	48.0	60.5	
					330 " " " "	46.1	52.5	

23	Hyper-immune.	216	1,300	First 10 cc. of big bleedings.	26.7	41.4	Bleeding lasted 37 min.; blood usually dark; struggled all the time while in the crate (1½ hrs.); all analyses run in duplicate; animal survived. (Fig. 8.)
				Last 10 " "	12.3	23.4	
				15 min. after end of "	12.3	23.3	
				30 " "	12.1	14.0	
				60 " "	2.0*	5.0*	
				287 " "	21.7	26.2	

* These values were obtained by plotting the values given in Van Slyke's tables and reading these values from the curve.

taken in the same way at the end of an approximate 5 hour interval. In most cases it was a simple matter to obtain the 5 hour sample. Occasionally it became necessary to cut the tail again. In such cases the fact has been noted.

In the first experiment of this kind, samples were collected for analysis by both methods when 30 and 60 minutes had elapsed after the big sample had been drawn. In this case, as is shown by Curves I and II, Fig. 5, the drop in alkaline reserve was comparatively small, the lowest point being reached at the 30 minute interval. The 5 hour sample showed that the alkaline reserve

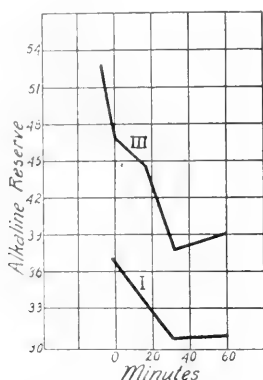

FIG. 6. Curve III (alveolar air method) and Curve I (open vessel method) illustrate the performance of Sow 21, a hyperimmune, during a second hemorrhage (Table IV).

was very nearly at its original value. Since the drop in alkaline reserve was so small (about 5 volumes per cent) it seemed likely that the low point on the curve had been missed. In the subsequent experiments, samples were taken 15 minutes after the end of the large bleeding also.

Curves III and IV, Fig. 5, show the performance of the same animal 7 days later, the total quantity of blood drawn being slightly larger than that taken the previous week. In this case, the alkaline reserve was consistently lower throughout. The drop in alkaline reserve on that day, due, presumably, to loss of blood, was much greater; the lowest point being reached at the end of 15 minutes.

Considerable data of this nature were accumulated, without any attempt at further analysis of these samples. The data are summarized in Table IV, and expressed graphically in Figs. 5, 6, 7, and 8. Further information concerning the drop in alkaline reserve associated with loss of blood is furnished by subsequent more elaborate experiments.

These experiments were of particular interest inasmuch as they indicated that there was great variation in the drop in alkaline reserve due to hemorrhage. It is a well recognized fact that after loss of blood, the blood volume is rapidly restored, and an efficient

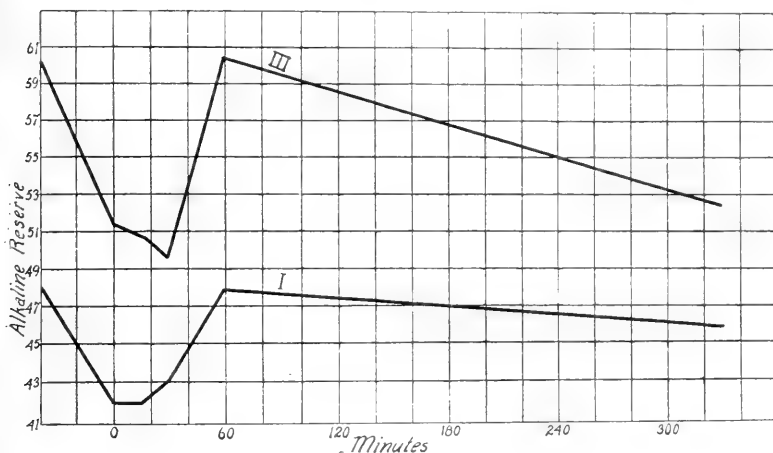

FIG. 7. Curve III (alveolar air method) and Curve I (open vessel method) illustrate the effect of a first hemorrhage on Sow 22 (Table IV).

blood pressure consequently maintained, by a dilution of the blood with the tissue fluids. Consequently, a drop in the total nitrogen content of the blood might be expected.

Two pigs (females, Nos. 7 and 8), which were not hyperimmune, were bled in the usual manner, the alkaline reserve values (obtained by the open vessel method) being recorded in Tables V and VI, and plotted in Figs. 9 and 10. Three successive bleedings were made on these two animals, at weekly intervals. The total nitrogen of the blood was determined by the Kjeldahl method, the samples being weighed in all cases. The results are averages of closely agreeing triplicate determinations. The usual drop in

percentage of nitrogen in 5 hours, due to hemorrhage of this magnitude, was 0.3 to 0.4 per cent. No explanation is advanced for the unusual drop of 1.01 per cent found in the second bleeding (Table V). More data on this point will be presented later. This experiment illustrates the individual reaction of animals subjected to the same treatment. The animals described in Tables V and VI were similar in size, weight, and sex, but one

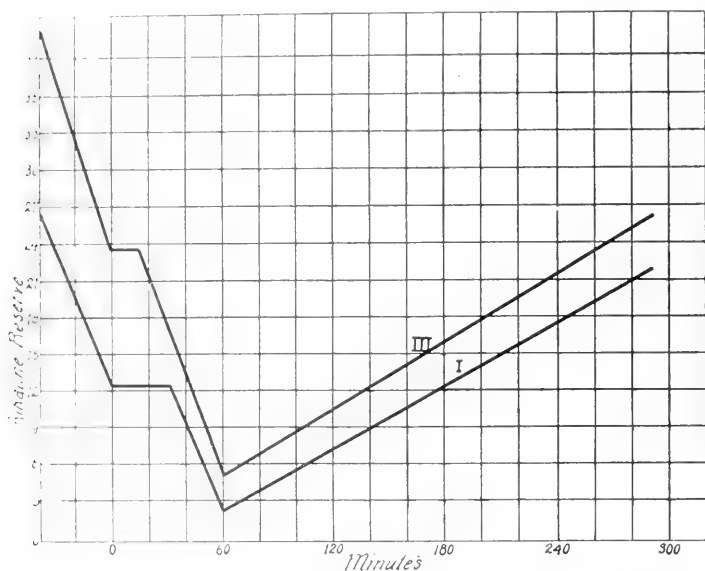

FIG. 8. Curve III (alveolar air method) and Curve I (open vessel method) illustrate the effect of a first hemorrhage on No. 23, a black male. The alkaline reserve values reached the lowest point encountered in this work. This experiment shows the combined effect of violent struggle plus hemorrhage in lowering alkaline reserve (Table IV).

suffered a greater loss in reserve alkali on bleeding than the other. No. 8 (Table VI) developed an acidosis, due to violent struggle and loss of blood, which was less severe, in terms of actual alkaline reserve values, than that developed by No. 7 (Table V, second bleeding) when she was quiet throughout. The drop in alkaline reserve was the same in both cases. It is evident from data gathered by the repeated bleeding of the same animal that the loss of reserve alkali immediately following hemorrhage was not

TABLE V.
Effect of Repeated Hemorrhage on Blood of Pig 7.

Date.	Weight. lbs.	Blood drawn. cc.	Time of sampling.	Alkaline reserve.		Total nitrogen.		Remarks.
				Volumes per cent.	Maximum drop.	Per cent.	Drop.	
1918 Oct. 4 1st bleeding.	270	1,625	First 10 cc. of big bleeding. Last 10 " " " 15 min. after end of " 30 " " " " 60 " " " " 325 " " " "	47.3 44.5 44.5 42.6 39.0 44.6	8.3	3.16	Fairly quiet throughout. (Fig. 9, Curve I.)	
Oct. 11 2nd bleeding.	280	1,680	First 10 cc. of big bleeding. Last 10 " " " 15 min. after end of " 30 " " " " 60 " " " " 297 " " " "	42.2 43.0 34.6 26.6 34.0 36.4	16.4	2.85 2.90	Fairly quiet throughout. (Fig. 9, Curve II.)	
Oct. 18 3rd bleeding.	276	1,650	First 10 cc. of big bleeding. Last 10 " " " 15 min. after end of " 30 " " " " 60 " " " " 300 " " " "	63.0 62.5 54.8 51.2 54.6 54.3	11.8	1.89 2.72	Fairly quiet throughout. (Fig. 9, Curve III.)	
							0.31 0.28	

TABLE VI.
Effect of Repeated Hemorrhage on Blood of Pig 8.

Date.	Weight.	Blood drawn	Time of sampling.	Alkaline reserve, Total nitrogen			Remarks.
				Vol- umes per cent.	Maxi- mum drop.	Per cent.	
Oct. 4 1st bleeding.	270	1,625	First 10 cc. of big bleeding.	56.7		2.89	Struggled considerably. (Fig. 10, Curve I.)
			Last 10 " " "	47.3			
			15 min. after end of "	47.3			
			30 " " " "	40.4	16.3		
			60 " " " "	44.6			
			288 " " " "	52.5		2.59 0.30	
Oct. 11 2nd bleeding.	298	1,790	First 10 cc. of big bleeding.	47.5		2.74	Uneasy during bleeding; then fairly quiet. (Fig. 10, Curve II.)
			Last 10 " " "	44.8	3.6		
			15 min. after end of "	43.9			
			30 " " " "	46.1			
			60 " " " "				
			260 " " " "	46.5		2.33 0.41	
Oct. 18 3rd bleeding.	276	1,650	First 10 cc. of big bleeding.	61.1		2.78	Fairly quiet throughout. (Fig. 10, Curve III.)
			Last 10 " " "	61.1	4.7		
			15 min. after end of "	56.4			
			30 " " " "	58.3			
			60 " " " "	58.3			
			283 " " " "	57.0		2.31 0.47	

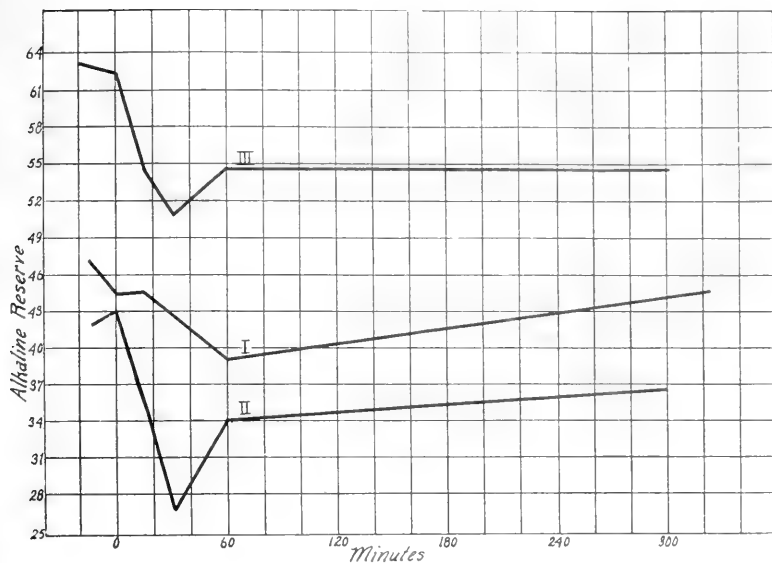

FIG. 9. Curves I, II, and III (open vessel method) illustrate the effect of a first, second, and third hemorrhage on a female, not hyperimmune (Table V).

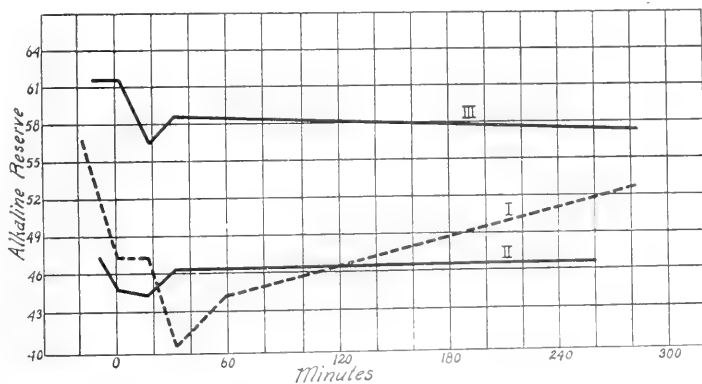

FIG. 10. Curves I, II, and III (open vessel method) illustrate the effect of a first, second, and third hemorrhage on a female, not hyperimmune (Table VI).

the only variation of alkaline reserve to which the animal was subject.

In many instances, the value obtained from the 5 hour sample was almost identical with that obtained from analysis of the first blood shed. The initial value obtained at the next series of bleedings, after the interval of 5 or 7 days, might be higher or lower. These animals were kept under ordinary farm conditions, and received a mixed diet.

Influence of Hemorrhage on Other Constituents.

These striking changes in the total nitrogen content of the blood made a study of the nitrogen distribution desirable.

Taylor and Lewis,⁷ working with dogs, found, when large quantities of blood were withdrawn hourly under continuous ether anesthesia, and the blood volume so lost was compensated by the injection of Ringer's solution, that the blood serum showed the following changes. (a) A progressive decrease in the total nitrogen and total protein of the serum was less than the theoretical dilution of the blood would account for. The authors found no evidence, however, for the assumption of any synthesis of serum globulin or serum albumin during the time of the experiments. (b) They also found such a large progressive rise in non-protein nitrogen of the serum that they concluded that the increase could not have been due to any mere washing out of the tissues. Urea and amino nitrogen were also found to be increased with bleeding. They said in conclusion, "It does not seem possible to resist the conclusion that the increase of non-protein nitrogen has been the result of an active process on the part of the tissues, due either to a setting free of stored amino-acids or to amino-acids derived from hydrolysis of tissue (cellular) protein or serum protein."

In the next experiment Pig 9 was bled seven times, the interval between bleedings being 5 days (with one exception). The alkaline reserve samples were collected at the usual intervals, whenever it seemed advisable to do so. Toward the end of the experiment, the blood clotted so rapidly and persistently that samples could not be obtained without cutting the tail. Non-

⁷ Taylor, A. E., and Lewis, H. B., *J. Biol. Chem.*, 1915, xxii, 71.

protein nitrogen was determined by the trichloroacetic acid modification of the Folin and Denis⁸ method. The ammonia was distilled according to the method of Bock and Benedict,⁹ and the distillate was Nesslerized. Urea was determined by Van Slyke and Cullen's¹⁰ modification of Marshall's urease method, the ammonia being Nesslerized according to the suggestion of Rose and Coleman.¹¹ Chlorides were determined by the method of McLean and Van Slyke,¹² the proteins being precipitated by means of copper sulfate in alkaline solution, according to the suggestion

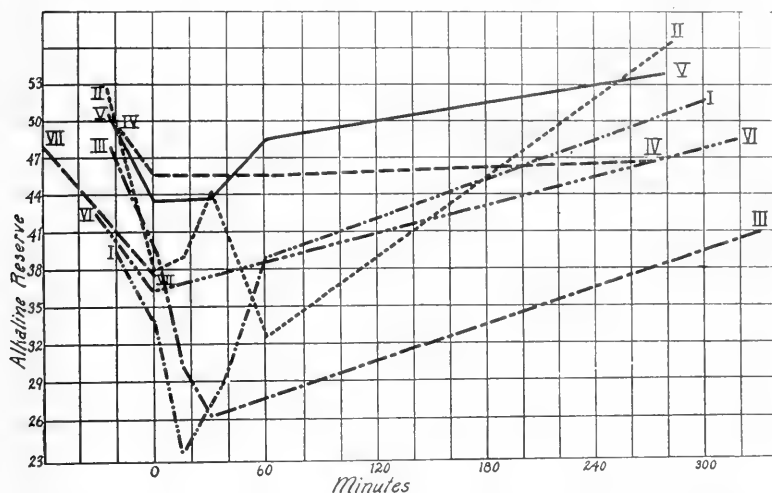

FIG. 11. Curves I to VII inclusive illustrate the effect of the first to the seventh bleeding of a female whose diet was limited to corn and tap water. (Table VII). All determinations were made by the open vessel method.

of Harding and Mason.¹³ All the determinations were run on whole blood, both on the first blood shed and also on the 5 hour samples. The results are summarized in Table VII and Fig. 11.

The diet of this animal was restricted to corn and tap water,

⁸ Greenwald, I., *J. Biol. Chem.*, 1915, xxi, 61.

⁹ Bock, J. C., and Benedict, S. R., *J. Biol. Chem.*, 1915, xx, 47.

¹⁰ Van Slyke, D. D., and Cullen, G. E., *J. Biol. Chem.*, 1914, xix, 211.

¹¹ Rose, A. R., and Coleman, K. R., *Biochem. Bull.*, 1914, iii, 411.

¹² McLean, F. C., and Van Slyke, D. D., *J. Biol. Chem.*, 1915, xxi, 361.

¹³ Harding, V. J., and Mason, E. H., *J. Biol. Chem.*, 1917, xxxi, 55.

TABLE VII.
Effect of Hemorrhage on Blood of Fig 9; Not Hyperimmune; Diet Limited to Corn and Water.

Date	Time of sampling	Volume per cent.	Alkaline reserve.	Total nitrogen.		Non-protein nitrogen.		Urea nitrogen.		Chlorides as NaCl.		Remarks.
				Per cent.	Difference	Per 100 gm.	Difference	Per 100 gm.	Difference	Per cent.	Difference	
Nov. 5 1st bleeding, 18 min.	Start of bleeding.	39.6		3.16						0.69		Uneasy toward end of bleeding, but did not struggle; fairly quiet after big bleeding; taken from crate at end of 1 hr. (Fig. 11.) Uneasy during bleeding; fairly quiet after; apparently exhausted when taken from crate at end of 1 hr.
	End "	34.0				27						
	15 min. after end.	23.7	15.9									
	30 "	26.0										
	60 "	38.7										
	300 "	51.7		2.72	-0.44	26	-1			0.75	+0.06	
Nov. 10 2nd bleeding, 27 min.	Start of bleeding.	52.7		2.57		29				0.74		Very restless during bleeding; squealed vociferously; breathed heavily; respiration 160 per min. at end of $\frac{1}{2}$ hr. (normal = 25-30); typical air hunger; tail would not bleed at end of 1 hr.; respiration 60; apparently normal after 5 hrs., respiration 40.
	End "	37.8										
	15 min. after end.	38.7										
	30 "	44.0										
	60 "	32.4	20.3									
	285 "	56.4		2.35	-0.17	29	=0.			0.76	+0.02	
Nov. 16 3rd bleeding, 24 min.	Start of bleeding.	48.0		2.50		28				9		
	End "	39.3										
	15 min. after end.	30.6										
	30 "	26.6	21.4									
	60 "											
	330 "	41.8		2.32	-0.27	34	+6	1.		+30.79	0.03	

Nov. 21 4th bleeding, 25 min.	257	770	Start of bleeding. End " " 30 min. after end. 60 " " " 270 " " "	50.4 45.8 45.8 45.8 46.7	4.6	2.54	31	13	0.73	Did not take full amount because of partial collapse of animal at previous bleeding; fairly quiet throughout; taken from the crate between samplings.	
Nov. 27 5th bleeding, 25 min.	256	1,470	Start of bleeding. End " " 30 min. after end. 60 " " " 275 " " "	50.4 43.7 43.7 48.5 54.0	4.7	2.68	24	8	0.73	Fairly quiet throughout; seemed to stand bleeding well; taken out of crate between samplings.	
Dec. 2 6th bleeding, 32 min.	256	1,400	Start of bleeding. End " " 315 min. after end.	42.4 36.4 48.5	6.0	2.45 2.87 2.32	28 29 32	+4 7 9	+60.72 0.74 +20.71	-0.01 -0.03	Extremely difficult to get samples, because of rapid clotting; pig nervous, but did not struggle. Almost impossible to get samples because of rapid clotting; tail cut again to get last sample; pig apparently in good condition.
Dec. 7 7th bleeding, 60 min.	255	1,500	Start of bleeding. End " "	47.3 37.3	10.0	2.74	27	7	0.74		

no salt being added to the ration. It is a recognized fact from the extensive work of Kerr, Hurwitz, and Whipple¹⁴ that diet plays an important part in the rate of regeneration of blood. Little work has been done, however, on the effect of diet on the chemical composition of the blood. The aim of this experiment was to investigate the ability of the animal to make good the losses in alkaline reserve, due to repeated severe hemorrhages on a poor and incomplete diet which was known to be acid-producing, without the addition of salts. In this experiment no records were kept of the daily intake, and the excreta were not analyzed.

The losses in alkaline reserve were much greater the first three times the animal was bled than they were subsequently, although the data on the last bleedings are not so extensive as might be desired, due to the great difficulty in obtaining samples. When a good arterial stream could not be obtained, the samples were not collected. Apparently the alkaline reserve value of the first blood shed on any day, under the conditions of these experiments, bears no relation to such factors as the number of times the animal has been bled previously, or the amount of blood taken at previous bleedings. Whether the variations in alkaline reserve from week to week are entirely due to the experimental procedure, or are influenced by other factors to some extent is difficult to say. It happens that the initial alkaline reserve on the 1st day when the animal was bled is the lowest initial value obtained, and that the initial value on the last day is very nearly as high as any obtained. It appears, then, that this animal was capable of maintaining an efficient alkaline reserve over a period of 5 weeks on a diet which was highly acid in character, even though a total volume of blood amounting to 10 liters was withdrawn from the system during this time. So far as could be ascertained no figures obtained by recent methods are available concerning the total amount of blood in the pig. If, however, one-twelfth of the body weight is assumed to be blood, then the theoretical volume of blood in the animal at the beginning of the experiment was approximately 9 liters. Since considerably more than the probable initial blood volume was withdrawn during this experiment, it is evident that a tremendous stimulus to metabolism was afforded.

In this connection, it is of interest to note the total nitrogen content of the blood at the various stages, and the distribution

¹⁴ Kerr, W. J., Hurwitz, S. H., and Whipple, G. H., *Am. J. Physiol.*, 1918-19, xlvii, 356, 370.

of the nitrogen, as far as data are available. Drops in the per cent of nitrogen during the first 5 hours after bleeding are of the same order of magnitude as those reported in the previous experiment. In this case, however, there was a further drop in nitrogen content after the first bleeding. The intervals between bleedings were shorter in this experiment than in the preceding experiment. Beginning with the fourth bleeding, it is interesting to watch the total nitrogen rise. The animal is evidently succeeding in restoring some of the lost protein of the blood, even under these conditions of repeated hemorrhage, until finally, with the seventh bleeding, the figure falls slightly. That the protein of the blood was actually being increased is evidenced by the data on the non-protein nitrogen and urea nitrogen content of the blood. Although in some cases these values were higher 5 hours after bleeding than at the beginning of bleeding, there seemed to be no great tendency for these forms of nitrogenous bodies to accumulate in the blood to any significant extent. It is to be expected that in the mobilization of nitrogenous compounds necessitated by the loss of blood, unavailable portions of nitrogenous compounds would have to be excreted; and hence that the normal products of protein metabolism would accumulate temporarily in the blood. Of course, the small rise in non-protein nitrogen and urea nitrogen indicated by analysis in reality represents a very much larger rise in these compounds when the conditions existing in the body are remembered. The blood has been largely diluted with tissue fluids and the total mass of actively functioning tissue (the blood) has been materially reduced. In some cases, a decrease of these bodies, as shown by analysis, might mean an actual increase in their production. The fourth bleeding, where a comparatively small volume of blood was withdrawn, is a case in point. Although no salts were added to this diet which is known to be poor in chlorides, the changes in the percentage of chlorides were too small to be significant.

DISCUSSION.

There was a great variation in the reaction of different animals to hemorrhages of the same relative magnitude, and in the reaction of the same individual at different times. When the

same individual was bled a number of times, in all cases in which the animal struggled the alkaline reserve values dropped lower than in those cases in which the animal remained quiet. This fact was so universal that it seems safe to conclude that, other factors being equal, the drop in alkaline reserve in pigs, following hemorrhages of this magnitude, varies directly with the amount of struggling. In many cases, bleeding was accomplished without any apparent struggle. In such cases the drop in alkaline reserve was always small. Doubtless, if more blood had been drawn the drop in alkaline reserve might have been considerably greater even though the animal remained perfectly quiet. Since larger hemorrhages were not attempted, no definite information can be reported on this point. It is true that there was considerable variation in the amount of blood drawn at different times, but there were so many other factors which influenced the alkaline reserve values that differences in these values could not be attributed entirely to differences in the volume of blood drawn. Table VII offers a case in point. In the case of the fourth bleeding, when a small volume of blood was removed, there was a small drop in alkaline reserve; but in the next bleeding, where almost twice the volume of blood was removed, the same drop in alkaline reserve was obtained. In the third bleeding when an unusually large volume was removed, there was a large drop in alkaline reserve, but this experiment was complicated by struggling. In general, when comparatively large volumes of blood were removed, there was a large drop in alkaline reserve, but in such cases the bleeding was almost invariably associated with struggle and restlessness. How much of the acidosis is attributable to actual loss of blood and how much to the struggling is difficult to say, the tendency to struggle doubtless being the direct result of the loss of blood.

The statement frequently made in the literature that hemorrhage is accompanied by loss in reserve alkali or by a condition of acidosis, has been based upon experiments, as far as the author has been able to ascertain, in which the experimental animal has been subjected to anesthesia. Since anesthesia is known to lower the alkaline reserve of an animal,⁵ the exact effect of the loss of blood is not clear. In the experiments described above this complicating factor has been eliminated. It is true that another

factor, struggle, has been introduced. The results obtained from the many hemorrhages which were successfully carried out without any apparent struggle afford evidence of the effect of loss of blood uncomplicated by anesthesia or struggle. The cases in which struggle took place are of particular interest inasmuch as more or less struggle usually accompanies the bleeding process. Furthermore, loss of blood in general is apt to be accompanied by struggle and nervous excitement.

Milroy's conclusion that there must have been very rapid compensatory passage of the tissue fluid into the circulation, the fluid first entering the circulation being extremely poor in reserve alkali, is not confirmed by these experiments in which the pig was the experimental animal and the Van Slyke apparatus was the means of measuring reserve alkali. In many cases the drop in alkaline reserve was slight. It is true that the hemorrhages which Milroy described were much more severe; but it seems reasonable to suppose that if the tissue fluids were poor in reserve alkali there would have been greater drops in alkaline reserve in many instances than were actually found.

The fact that one animal (Table VII and Fig. 11) when bled seven times at intervals of 5 days was able to maintain an efficient alkaline reserve throughout the experiment even though her diet was restricted to corn and water affords further evidence of the fact that acidosis is not the limiting factor which must be considered in the treatment of an animal which has lost a moderate amount of blood. It is true that diet undoubtedly is an extremely important factor in the rate of regeneration of blood.¹⁴

The rise in urea and non-protein nitrogen in the blood after bleeding might be caused by the breaking down of body proteins in an effort to replace the lost circulating protein. The urea might function also in maintaining normal osmotic relations.

CONCLUSIONS.

1. If the blood is allowed to flow directly from an artery into a paraffined vessel containing potassium oxalate, and if the blood so obtained is allowed to stand a definite time ($\frac{1}{2}$ to 2 hours)

before centrifugation, the alkaline reserve values obtained by analysis of the plasma by the Van Slyke method bear a fairly definite relation to the alkaline reserve of the blood as it exists in the body. These results can be duplicated with satisfactory accuracy.

2. Alkaline reserve values obtained in this manner are lower than values obtained when the blood is brought to a definite (CO_2) tension immediately after centrifugation, but, under definite conditions, are consistent with them.

3. When pigs were subjected to hemorrhages amounting to approximately 1.3 per cent of body weight, a study of the alkaline reserves of these animals immediately after the hemorrhages resulted in the following observations.

(a) Hemorrhages of this magnitude were usually accompanied by a somewhat lowered alkaline reserve during the first few hours after bleeding.

(b) When the animal remained perfectly quiet throughout the experiment, the drop in alkaline reserve was invariably small.

(c) If the animal struggled, the drop in alkaline reserve was much greater, this being noticeable soon after struggling took place.

(d) When the animal remained quiet, the maximum drop in alkaline reserve was reached within $\frac{1}{2}$ hour after the bleeding was completed. At the end of 5 hours, and often sooner, the alkaline reserve was near its original value.

(e) There was considerable variation in the reaction of different individuals.

(f) When the diet of one animal was restricted to corn and water and the animal was bled seven times at intervals of 5 days, the alkaline reserve value of the first blood shed on any day bore no relation to such factors as the number of times the animal had been bled previously, or the amount of blood (within the limits of these experiments) taken at previous bleedings.

4. The total nitrogen content of the blood always fell immediately after hemorrhage. There was a distinct tendency for the urea nitrogen and the non-protein nitrogen to rise. Although one animal was bled seven times while restricted to a diet of corn and water, the percentage of chlorides in the blood remained constant.

5. On an inadequate diet (corn and water) under conditions of repeated hemorrhage there was a distinct tendency toward regeneration of blood proteins.

Grateful acknowledgment is made of the valuable criticism and kindly cooperation of Professor Steenbock and Dr. Beach of the College of Agriculture, throughout the course of these experiments.

STUDIES OF BLOOD REGENERATION.*

II. EFFECT OF HEMORRHAGE ON NITROGEN METABOLISM.

By MARY V. BUELL.

(From the Department of Agricultural Chemistry, University of Wisconsin, Madison.)

(Received for publication, August 11, 1919.)

INTRODUCTION.

The changes in the chemical composition of the blood of the pig under conditions of repeated hemorrhage, reported in the previous paper¹ are of interest in the light of investigations of the effect of hemorrhage and acidosis on metabolism. Hawk and Gies² concluded that in dogs in nitrogen equilibrium hemorrhage stimulated nitrogen excretion. Kerr and his coworkers³ found that after plasmapheresis "The basal nitrogen metabolism shows no constant variation under these experimental conditions, with the exception of a primary rise in nitrogen elimination which occurs in the few days following the shock of the plasmapheresis." Haskins⁴ found a decided rise in the amount of total nitrogen excreted on the 2 days following hemorrhage.

EXPERIMENTAL.

Pig A, a female weighing 330 pounds, was confined in a large metabolism cage, and was fed 5 pounds of corn (maize meal) each day, and 4 liters of distilled water. (Later 5 liters of water

*The work described in this article forms part of a thesis submitted in partial fulfillment of the requirements for the degree of Doctor of Philosophy in the University of Wisconsin.

¹ Buell, M. V., *J. Biol. Chem.*, 1919, xl, 29.

² Hawk, P. B., and Gies, W. J., *Am. J. Physiol.*, 1904, xi, 171.

³ Kerr, W. J., Hurwitz, S. H., and Whipple, G. H., *Am. J. Physiol.*, 1918-19, xlvii, 356.

⁴ Haskins, H. D., *J. Biol. Chem.*, 1907, iii, 321.

TABLE I.

Effect of Repeated Hemorrhage on Urine of Pig A.

Date	Volume cc.	Specific gravity	Re- action	Total nitrogen	Uric acid	Uric acid from total N.		Creati- nine	Creati- nine N from total N.		Creatine from total N.	Ammo- nia N.		Urea N total N.	Urea N total N.		P ₂ O ₅	P ₂ O ₅ N	
						mg.	per cent		gm.	per cent		gm.	per cent		gm.	per cent			
1919																			
Jan. 11	820	1.037	5.8	19.3	309	0.48	1.56	2.17	322	0.52	2.22	11.5	13.4	69.5	1.18	0.22			
" 12	1,580		5.8	16.1	311	0.58	1.64	2.74	281	0.54	3.07	19.0	11.3	70.0	1.18	0.26			
" 13	2,525	1.013	6.8	16.6	282	0.51	1.41	2.29	363	0.68	2.75	16.5	11.8	70.9	2.63	0.16			
" 14	2,300	1.011	6.0	14.8	308	0.62	1.41	2.55	314	0.66	2.12	14.6	10.5	70.8	3.91	0.26			
" 15	2,675	1.010	6.0	17.4	366	0.63	1.69	3.00	372	0.66	2.59	14.8	12.3	70.7	4.05	0.23			
" 16	2,200	1.006	6.6	10.6	243	0.69	1.13	2.88	268	0.79	1.45	13.7	7.5	71.4	2.35	0.22			
" 17	3,310	1.007	5.6	25.5	418	0.49	2.45	2.58	439	0.54	3.92	15.4	16.4	64.4	6.27	0.25			
" 18	1,375	1.020	5.9	19.3	397	0.62	1.64	2.29	657	1.06	3.98	20.6	13.7	71.2	5.40	0.28			
" 19	2,350	1.014	6.0	22.7	329	0.43	1.72	2.04	831	1.14	3.32	14.6	15.8	69.7	5.20	0.23			
" 20	2,525	1.012	6.6	24.7	303	0.37	2.16	2.35	692	0.87	4.03	16.3	13.9	56.4	6.47	0.26			
" 21	1,415	1.014	6.6	14.7	271	0.55	1.58	2.88	619	1.31	2.78	18.8	8.9	60.2	3.73	0.25			
" 22	1,000	1.010	6.4	7.9			0.85	2.91	188	0.74					1.79	0.23			
" 23	2,300	1.023	6.4	26.4	419	0.48	2.83	2.89	278	0.33					9.85	0.37			
" 24	1,150	1.011	5.8	9.1	128	0.42	0.87	2.51	121	0.41	1.84	14.6	16.2	61.7	2.42	0.26			
" 25	1,050	1.018	5.8	14.6	256	0.52	1.36	2.50	481	1.02	1.95	13.3	10.2	69.9	3.38	0.23			
" 26	3,200	1.010	5.6	25.3	425	0.50	2.51	2.67	810	1.00	3.13	12.3	18.2	71.9	6.44	0.25			
" 27	780	1.013	5.6	7.7	112	0.44	0.80	2.82	294	1.19	0.98	12.8	5.3	69.4	1.67	0.22			
" 28	3,250	1.013	6.6	23.6	406	0.51	2.55	2.90	1,121	1.48	4.71	19.9	14.3	60.7	8.61	0.36			
" 29	2,020	1.012	5.6	13.6	263	0.46	1.46	2.87	428	0.98	1.85	13.5	9.5	66.8	6.33	0.46			
" 30	2,000	1.008	5.6	10.5	188	0.53	1.21	3.08	237	0.70	1.43	13.5	7.3	69.0	4.75	0.45			
" 31	2,600	1.015	6.8	14.9	278	0.57	1.48	2.67	270	0.45			5.2	35.4	6.92	0.46			

Feb.	1	1,750	1.017	5.8	20.3	348	0.51	1.81	2.40	825	1.26	3.95	19.4	10.7	52.8	5.20	0.25
"	2	2,500	1.010	5.9	14.6	188	0.38	1.41	2.60	572	1.22	2.00	13.7	10.5	71.8	4.26	0.29
"	3	2,500	1.017	5.6	29.0	441	0.46	2.58	2.40	1,513	1.63	7.13	24.6	16.1	55.5	10.83	0.37
"	4	2,700	1.016	5.6	21.7	377	0.52	1.97	2.41	923	1.32	2.82	13.0	15.4	70.9	7.16	0.33
"	5	1,950	1.010	5.6	11.7	293	0.52	1.05	2.41	435	1.15	1.49	12.7	8.7	74.1	4.71	0.40
"	6	2,120	1.017	5.6	19.7	356	0.54	1.82	2.48	542	0.85	5.50	27.9	10.5	53.2	7.06	0.36
"	7	3,500	1.012	5.6	29.3	464	0.47	2.77	2.54	956	1.01	6.87	23.4	17.1	58.3	10.29	0.35
"	8	1,175	1.020	5.8	20.1	455	0.68	1.58	2.10	1,053	1.63	1.79	8.9	14.4	71.5	3.92	0.19
"	9	2,550	1.018	6.1	10.6	177	0.50	1.27	3.22	537	1.57	1.94	18.2	12.3		3.16	0.33
"	10	3,000		6.4	29.3	482	0.49	2.50	2.29	1,018	1.08	5.22	17.7	19.0	65.0	7.52	0.26
"	11	2,450	1.009	6.0	12.7	223	0.52	1.13	2.39	605	1.47					3.71	0.29
"	12	1,900	1.013	5.6	18.5	330	0.53	2.20	3.19	946	1.59	2.84	15.6	12.3	66.3	5.78	0.31

were given.) No salts were added. After the animal had been kept under these conditions for 5 days, daily collections of the complete urinary excretion were made, and the following determinations were made: volume, specific gravity, hydrogen ion concentration by the Clark and Lubs⁵ method, total nitrogen by the Kjeldahl method, uric acid by the Benedict-Hitchcock⁶ modification of the Folin-Denis method, creatinine by Folin's colorimetric method, creatine by the Folin-Benedict⁷ method, ammonia nitrogen by Folin's aeration method, urea by Van Slyke and Cullen's⁸ modification of Marshall's urease method, the ammonia formed being titrated, and total phosphates by titration with uranium acetate. The animal was bled four times at intervals

TABLE II.
Period Averages of Urinary Analysis of Pig A.

Date.	Total nitrogen.		Creatinine.		Creatinine N from total N.		Creatine as creatinine.		Creatine N from total N.		Uric acid.		Uric acid N from total N.		Ammonia N.		Ammonia N from total N.		Urea N.		Urea N from total N.		Phosphates as P_2O_5 .		$\frac{P_2O_5}{N}$		
	gm.	gm.	per cent	mg.	per cent	mg.	per cent	gm.	per cent	gm.	per cent	gm.	per cent	gm.	per cent	gm.	per cent	gm.	per cent	gm.	per cent	gm.	per cent				
1919																											
Jan 11-17	17.21	1.61	2.52	337	0.61	320	0.56	2.59	15.4	11.9	69.2	3.95	0.23														
" 18-24	17.81	1.66	2.51	484	0.84	358	0.60	3.09	17.0	12.0	68.0	4.99	0.28														
" 25-31	15.81	1.62	2.77	520	1.03	274	0.52	3.06	19.4	10.1	64.1	5.45	0.34														
Feb. 1-7	20.91	1.90	2.44	823	1.23	340	0.49	4.25	20.3	12.7	60.8	7.07	0.34														
" 8-12	18.51	1.75	2.61	832	1.17	331	0.54	2.95	15.2	15.2	67.6	4.88	0.28														

of 7 days, in the ordinary manner from the tail, approximately 6 cc. of blood per pound of body weight being taken. The results of the daily analysis of the 24 hour collection of urine are given in Table I, and the period averages of these same data in Table II. The breaks in Table I indicate the occurrence of hemorrhage. The results of the blood analysis are given in Table III. The determinations, in this case, were made as described previously,¹ with the exception that the ammonia in the urea determinations was titrated

⁵ Clark, W. M., and Lubs, H. A., *J. Bacteriol.*, 1917, ii, 1.

⁶ Benedict, S. R., and Hitchcock, E. H., *J. Biol. Chem.*, 1915, xx, 619.

⁷ Benedict, S. R., *J. Biol. Chem.*, 1914, xviii, 191.

⁸ Van Slyke, D. D., and Cullen, G. E., *J. Biol. Chem.*, 1914, xix, 211.

instead of Nesslerized, a 5 cc. sample of blood being taken. The alkaline reserve values from this series of bleedings are plotted in Fig. 1. In general, the data illustrate the points which have already been discussed.¹ Of particular interest are the results

TABLE III.
Effect of Hemorrhage on Blood of Pig A.

Date.	Blood taken.	Duration of bleeding.	Time of sampling.	Alkaline re-serve.		Urea N per 100 cc. of blood.	Remarks.
				vol. per cent	Total N.		
1919	cc.	min.		vol. per cent	per cent	mg.	
Jan. 17	1,900	16	Beginning of bleed- ing.	48.1	2.89	26.3	Fairly quiet throughout.
			End of bleeding.	44.9			
			120 min. after end.	44.9	2.59	32.0	
" 24	2,100	18	Beginning of bleed- ing.	50.7	2.45	32.4	Fairly quiet throughout.
			End of bleeding.	50.7			
			15 min. after end.	50.7			
			120 min. " "	50.7	2.20	35.6	
" 31	1,850	30	Beginning of bleed- ing.	51.6	2.55	33.7	Quiet at first. Struggled con- siderably toward end of bleeding. Had to cut the tail to get the 15 min. sample.
			15 min. after end.	37.4			
			120 " " "	51.4	2.16	38.5	
Feb. 7	1,850	19	Beginning of bleed- ing.	53.4	2.53	26.0	Quiet at first. Struggled to- ward end of bleeding. Left pig in crate to take the hour sample but could not get a good stream. Blood clotted very rap- idly. Animal quite exhausted but did not de- velop air hunger.
			15 min. after end.	20.6	2.11	26.5	

obtained at the second bleeding, January 24. In this case, there was no drop in reserve alkali at all, even though a larger amount of blood was taken than at any other bleeding in the series. In the case of the fourth bleeding, February 7, the drop was extremely rapid, but there were no symptoms of air hunger, and the animal apparently suffered no untoward effects from the experiment.

The total nitrogen content was influenced by the hemorrhages much as in the previous experiments. Urea nitrogen was distinctly higher at the end of 2 hours than at the beginning of bleed-

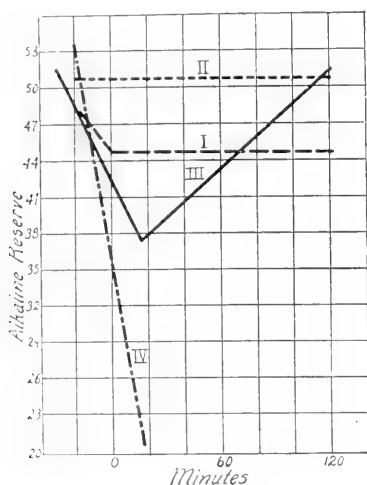

FIG. 1. Curves I, II, III, and IV illustrate the effect of the first, second, third, and fourth hemorrhage on the alkaline reserve of Pig A, which was kept in a metabolism cage and restricted to a diet of corn and distilled water (Tables I, II, and III). All determinations were made by the open vessel method.

ing. In the last bleeding (February 7) a determination of urea nitrogen was made at the end of 15 minutes. At this time the urea nitrogen was the same (a very slight rise) as at the beginning of the bleeding, although the total nitrogen had dropped considerably. In general, bleeding had the effect of raising the urea content of the blood within a short time after the blood was shed, and there was a tendency for the urea to remain high, although it dropped back to the original figure before the end of the experiment, in spite of the fact that the hemorrhages were regularly

repeated at intervals of 7 days. During this time of high urea content in the blood there was no increase in the excretion of urea in the urine (Table II).

In order to study the effect of hemorrhage on endogenous nitrogen metabolism, another animal, Pig B, a female, weighing 360 pounds, was confined in a metabolism cage, and after being fasted for 3 days, was offered distilled water and starch to which sufficient sodium chloride had been added to make the ration palatable enough to induce the animal to eat. After 3 days of starch feeding the sodium chloride was discontinued and daily collections of the urine were made. During the remainder of the experiment the animal received 4 pounds of corn-starch daily and about 5 liters of distilled water. In this way, exogenous nitrogen metabolism was reduced to a minimum, but sufficient calories were provided to cover the energy expenditure of the animal. The results of the daily analysis of the complete urinary excretion are given in Table IV, and the period averages of these results in Table V. This animal was bled twice, and 6 cc. of blood per pound of body weight were taken, the interval between bleedings being 5 days. The alkaline reserve values are given in Table VI.

Soon after the pig was taken from the crate at the end of the 1 hour period, she developed a severe case of air hunger. The respiration was shallow and rapid, about 180 a minute. She refused food and water and was extremely nervous. After several hours an attempt was made to give the animal distilled water by rectum. Several hundred cc. were retained. There was no urine during the first 24 hours after the bleeding. The urine on the following day was collected and analyzed in two separate portions. It was very deeply pigmented. On the following day, March 3, the pig was apparently much better. The respiration seemed normal. She had no difficulty in moving about, but continued to refuse food and water. Consequently the experiment was discontinued, and in an effort to save the animal 3 liters of milk in which 10 gm. of sodium acetate had been dissolved were administered by stomach tube. At night the pig was apparently normal, but was found dead in the morning, March 4, death being caused by a severe hemorrhage of the lungs. There was no reason to believe that death was due directly to the specific effects of the experimental procedure.

TABLE IV.

Daily Analysis of Urine of Pig B.

Date.	Urine.	Reaction.	Specific gravity.	Total N.		Creatinine.		Creatinine N from total N.		Creatinine as creatinine.		Creatinine N from total N.		Uric acid.	Uric acid N from total N.		Phosphates as P ₂ O ₅ .	P ₂ O ₅ /N
				gm.	gm.	per cent	mg.	per cent	mg.	per cent	mg.							
1919	cc.	pH																
Feb. 20	0																	
" 21	5,200	6.2	1.008	12.9	3.93	8.19	465	1.12	532	1.23	3.44	0.266						
" 22	4,150	6.6	1.006	9.5	1.90	5.46	432	1.41	374	1.17	2.63	0.275						
" 23	3,300	6.6	1.005	7.5	2.20	7.88	392	1.63	326	1.30	1.66	0.222						
" 24	2,650	6.6		4.6	1.47	8.60	112	0.75	189	1.23	0.92	0.201						
" 25	2,000	6.0	1.009	9.0	2.48	7.38	392	1.35	422	1.40	2.12	0.235						
" 26	2,900	6.4	1.006	7.6	1.63	5.70	347	1.41	249	0.97	0.95	0.124						
" 27	2,725	6.0	1.006	7.3	1.74	6.35	204	0.86	252	1.02	1.80	0.244						
" 28	4,300	6.0	1.003	7.8	2.53	8.66	358	1.42	288	1.10	1.83	0.233						
Mar. 1	3,700	5.8	1.002	5.0	2.22	11.83	345	2.12	304	1.81	1.13	0.225						
" 2	0																	
" 3	2,960			27.0	2.93		7,202	8.31	580	0.64	6.60	0.244						
" 3a*	1,460	6.0	1.021	12.2	1.58	3.47	3,789	9.62	292	0.71	3.50	0.28						
" 3b*	1,500	6.2	1.018	14.7	1.34	2.46	3,412	7.22	288	0.59	3.09	0.21						

* The urine excreted during this day was collected and analyzed in two separate portions, *a* and *b*; *a* represents the period from 8 a.m., March 2, to 5 p.m., March 2; *b* represents the period from 5 p.m., March 2, to 8 a.m., March 3.

The breaks in the table indicate the occurrence of hemorrhage.

TABLE V.

Period Averages of Urinary Analysis of Pig B.

Date.	Total N.	Creatinine.	Creatinine N from total N.		Creatinine as creatinine.		Uric acid.	Uric acid N from total N.		Phosphates as P ₂ O ₅ .	P ₂ O ₅ /N
			gm.	per cent	mg.	per cent		mg.	per cent		
Feb. 20-24	6.9	1.904	7.39	280	1.26	284	1.23	1.73	0.25		
" 25-Mar. 1	7.1	2.125	7.70	329	1.33	303	1.18	1.57	0.20		
Mar. 2-3	15.5	1.467	2.92	3,600	8.31	290	0.64	3.30	0.24		

TABLE VI.
Effect of Hemorrhage on Blood of Pig B.

Date.	Blood taken.	Duration of bleeding	Time of sampling.	Alkaline reserve.		Total N.	Remarks.	
				vol per cent.	per cent.			
1919	cc.	min.						
Feb. 24	2,100	30	Beginning of bleed-	53.8	3.06		Pig was quiet until the last $\frac{1}{2}$ hr. Then she struggled intermit-	
			ing.					
			End of bleeding.	56.0				tently. Seemed ex-
			15 min. after end.	56.0				hausted at the end
			30 " " "	53.8				of the hour. Respi-
60 " " "	43.9	2.86	ration was heavy and deep, about 70 per min.					
Mar. 1	2,100	45	Beginning of bleed-	49.0	2.74		Pig fairly quiet while in the crate. Strug-	
			ing.					
			15 min. after end.	56.6				gled a little inter-
			30 " " "	44.8				mittently during the
60 " " "	50.1	2.45	last $\frac{1}{2}$ hr.					

DISCUSSION.

The data obtained on the effect of repeated hemorrhage on the composition of the blood of pigs (Tables III and VI, and Figs. 1 and 2) supplement the data already reported in the previous paper. In one case, Fig. 1, Curve II, there was no drop in alkaline reserve after hemorrhage.

The data obtained from the urinary analysis of Pig A (Tables I and II) give no definite indication of increased nitrogen excretion due to hemorrhage. Although the collections were made at the same time each day, it is evident that in some cases the urine so obtained in reality represented a longer period than 24 hours, and in other cases a shorter period. When period averages are considered, the values vary in each direction and therefore cannot be interpreted as demonstrating a significant change. In the case of Pig B, however, where the nitrogen excretion represented endogenous metabolism only, there is a definite indication of increased nitrogen metabolism. This fact might be interpreted

as meaning that when no protein was furnished from which the animal could obtain fragments necessary to replace the lost tissue, there was greater autolysis of body tissue to make good the loss and also greater activity of the blood-making organs with a correspondingly increased excretion of the end-products of the metabolism of these organs. Since the data on the effect of hemorrhage on endogenous nitrogen metabolism is so limited, and since the experiment terminated fatally to the animal, leaving room for doubt as to the exact nature of the cause of death, too much stress should not be placed on the results.

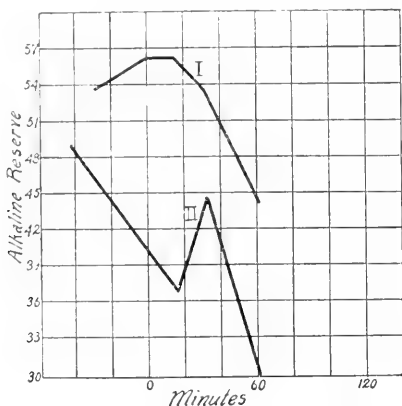

FIG. 2. Curves I and II (open vessel method) illustrate the effect of the first and second hemorrhages on Fig B. The pig was kept in a metabolism cage and the diet was restricted to starch and water. The last point on Curve II represents a sample of blood taken just before severe symptoms of air hunger set in (Tables IV, V, and VI).

In the case of Pig A the effect of hemorrhage on uric acid metabolism was too small to be significant. According to the theory of Lewis and his coworkers,⁹ amino-acids stimulate all cellular metabolism, with the result that after protein ingestion (in man) there is an increased excretion of uric-acid. If hemorrhage causes autolysis of tissue protein, an increased excretion of uric acid might be expected. Uric acid, however, is not the only end-product of purine metabolism in the pig. Under

⁹ Lewis, H. B., Dunn, M. S., and Doisy, E. A., *J. Biol. Chem.*, 1918, xxxvi, 9.

the stress produced by hemorrhage, it is conceivable that purine metabolism might be carried out of its normal course. In the case of Fig B, where uric acid excretion was entirely endogenous, the effect of the first bleeding is not clear. If amino-acids stimulate uric acid excretion, it would be expected that total nitrogen and uric acid would run parallel and consequently that the per cent of uric acid nitrogen would not rise. The fact that there was an increased uric acid excretion on the day following bleeding does not necessarily mean that there was an increased production of uric acid during that day, because of the uncertainty of the

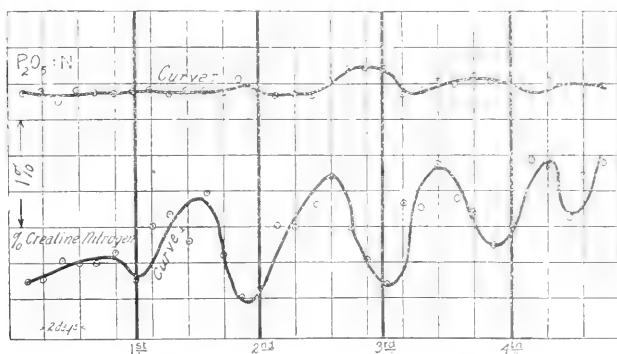

FIG. 3. Curve I represents the daily urinary fluctuation in the per cent of creatine nitrogen of total nitrogen. Days on which bleeding took place are represented by vertical lines. Bleeding stimulates creatine elimination. Curve II represents the daily fluctuation in the ratio of P_2O_5 to nitrogen. This ratio rises after the 18th day, and falls again on the day following bleeding (Fig A, Table I).

accuracy with which the samples represented a 24 hour period. The period averages show a slight increase in uric acid production after the first bleeding, too small, however, to be significant. If the first collections of urine after the second bleeding (there was no urine on the first day) represented a 48 hour excretion, then the actual amounts of uric acid excreted remained remarkably constant. In any case, the uric acid excretion was not at all proportional to the total nitrogen. Although there is no experimental evidence for this view, it is conceivable that those tissues which are comparatively low in nucleic acid, such as the

muscles, were autolyzed to a great extent, with the result that uric acid excretion was not proportional to nitrogen excretion.

Much emphasis has been laid on the constancy of the creatinine excretion for each individual. Haskins,⁴ however, found a significant decrease in the creatinine excretion following hemorrhage. It is true that in the case of Pig A there was considerable daily variation in the amounts of creatinine excreted. The percentages of creatinine nitrogen were fairly constant, however, particularly when period averages are considered. It happens that in each case there was a slightly diminished excretion of creatinine nitrogen, expressed as percentage of total nitrogen, on the day following bleeding. These drops fall well within the limits of daily variation, however, and therefore cannot be considered significant. An apparent fall in the per cent of creatinine nitrogen might, of course, be due to a corresponding increase in total nitrogen excretion. This experiment, therefore, affords no evidence that repeated hemorrhages of this magnitude influence the excretion of creatinine. In the case of Pig B, the period averages might seem to indicate that there was a significant reduction in creatinine output after the second bleeding. This effect, also, is directly dependent upon the accuracy with which this collection of urine represented the excretion of the 48 hours following bleeding. Since this point is in doubt, there is little reason to think that the creatinine value was actually lowered by bleeding.

In the case of Pig A, there seems to be no doubt that hemorrhage increased the excretion of creatine when both actual amounts of creatine and percentage of creatine nitrogen are considered. According to the conception of Underhill,¹⁰ that acidosis is a determining factor in the excretion of creatine (in rabbits) this result might be explained on the basis of the fact that hemorrhage is accompanied by lowered alkaline reserve. Several facts, however, are in opposition to this view. The data here presented on the effect of hemorrhage on alkaline reserve, ammonia excretion, and the hydrogen ion concentration of the urine, all point toward the fact that the acidosis produced by this experimental procedure was usually slight and of brief duration. Steenbock and Gross,¹¹

¹⁰ Underhill, F. P., *J. Biol. Chem.*, 1916, xxvii, 127.

¹¹ Steenbock, H., and Gross, E. G., *J. Biol. Chem.*, 1918, xxxvi, 265.

working with pigs, found that intensive protein-feeding resulted in increased creatine production even during alkalosis. The conclusion seems more plausible, therefore, that the increased creatinuria was caused by an alteration in the course of nitrogen metabolism due to hemorrhage.

When the exogenous nitrogen metabolism was eliminated (Fig B), the second bleeding brought about a tremendous rise in the

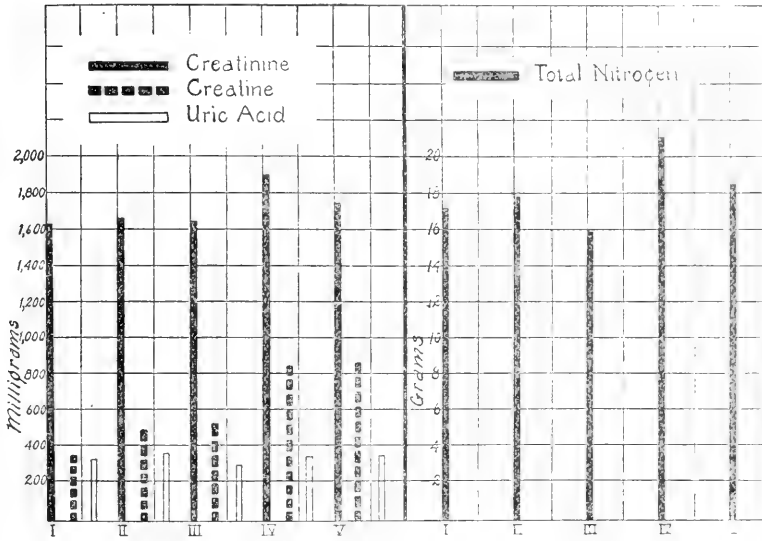

FIG. 4. The vertical lines represent the averages of the actual amounts of creatinine, creatine, uric acid, and total nitrogen respectively excreted during the various periods of the experiment. Line I represents the fore period, Line II the period between the first and second hemorrhages, Line III the period between the second and third hemorrhages, etc. (Fig A, Table II).

amount of creatine excreted, and also in the per cent of creatine nitrogen. It is true that other unknown factors beside simple hemorrhage may have entered into this effect. The picture suggests itself, however, that when the blood stream is suddenly flooded with the fragments resulting from the breaking down of protein of either endogenous or exogenous origin in such large amounts that the organism is unable to metabolize them in the

ordinary way, an increased creatine production and excretion results.

There are considerable data in the literature to show that acid-feeding, if sufficiently intensive, produces an increased excretion of phosphates in the urine in animals. Goto¹² found that acid-feeding produced no definite influence on the distribution of phosphates between urine and feces of rabbits. The data for Pig A show that the phosphate excretion in the urine was fairly constant until the 18th day of the experiment. At this point the ratio $\frac{P_2O_5}{N}$ rose definitely. This fact shows clearly, if it is assumed that there was no corresponding fall in fecal phosphate, that alkaline phosphates were being lost from the body, presumably to help neutralize the excess acid formed. The fact that the next two bleedings were followed on the next day by a decreased $\frac{P_2O_5}{N}$ ratio may indicate that the readily available phosphates were exhausted at the time, due to loss of large quantities of phosphoric acid in the blood withdrawn. In the case of Pig B, the $\frac{P_2O_5}{N}$ ratio remained fairly constant throughout. This effect would be expected on account of the short duration of the experiment; but it is of particular interest inasmuch as the nitrogen figure rose so high after the second bleeding, and no phosphates were supplied with the food.

It is a rather remarkable fact that the hydrogen ion concentration of the urine of Pig B suffered so little change after the second bleeding during the 48 hours when the animal was suffering from acute air hunger.

In the alkaline reserve values (Table VI) obtained after the second hemorrhage is found an interesting example of a preliminary fall in alkaline reserve with the usual attempt at rapid restoration, followed by a second sharp fall. It is unfortunate that samples of blood could not be drawn during the entire period of air hunger.

¹² Goto, K., *J. Biol. Chem.*, 1918, xxxvi, 355.

CONCLUSIONS.

1. On a diet of corn and water, under conditions of repeated hemorrhage, the creatine excretion of two animals (pigs) was definitely increased. This effect was cumulative.

2. When the diet was restricted to starch and water, the second hemorrhage caused an increased excretion of total nitrogen, phosphates, and creatine.

3. The theory that hemorrhages amounting to 6 cc. per pound of body weight are not necessarily accompanied by a severe grade of acidosis is supported by the following observations.

(a) The drops in alkaline reserve were slight and of short duration.

(b) There was no great increase in the ammonia nitrogen excretion after hemorrhage.

(c) The hydrogen ion concentration of the urine was not definitely influenced by hemorrhage.

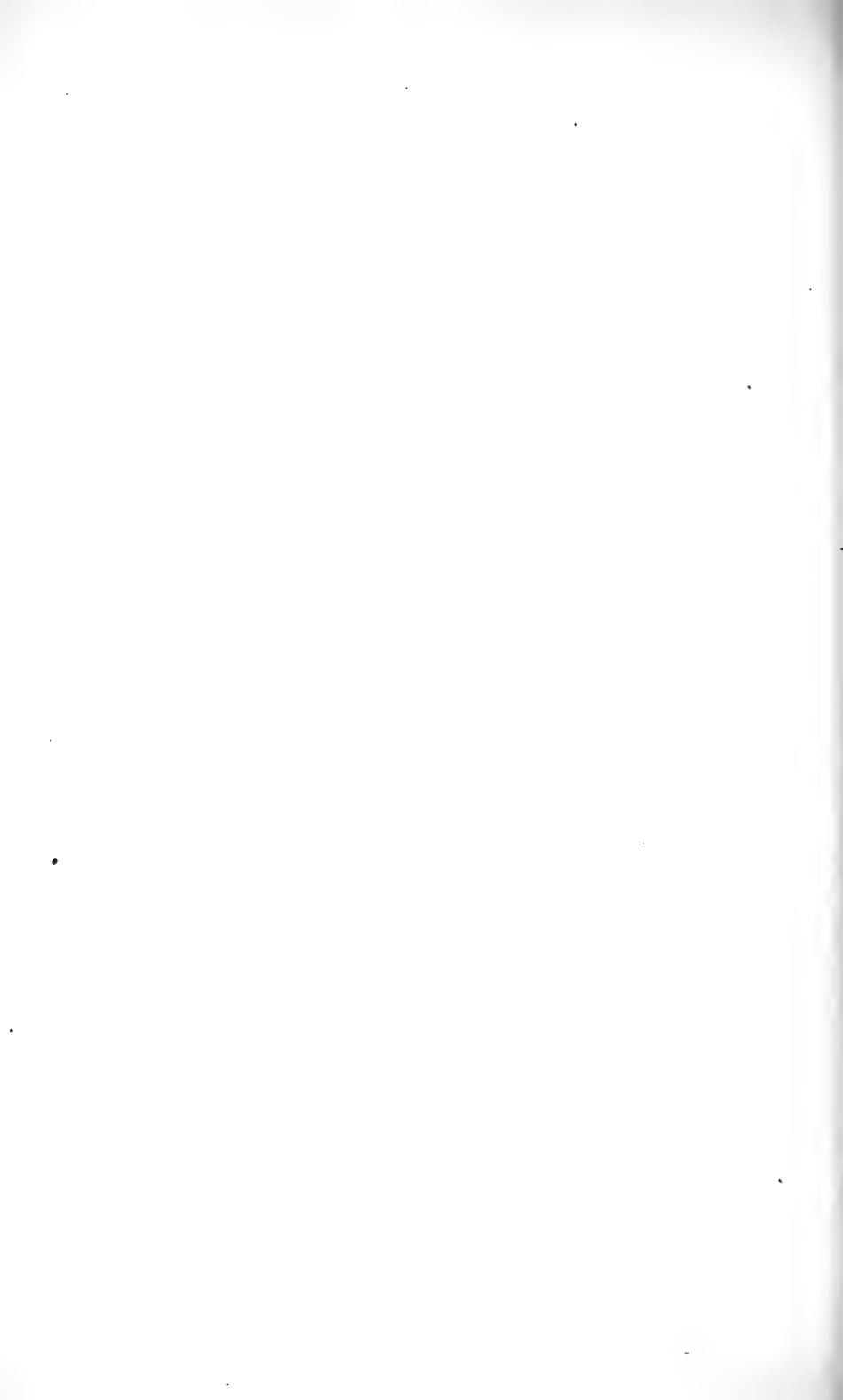

ANIMAL CALORIMETRY.

SIXTEENTH PAPER.

THE INFLUENCE OF LACTIC ACID UPON METABOLISM.*

BY H. V. ATKINSON AND GRAHAM LUSK.

WITH THE TECHNICAL ASSISTANCE OF G. F. SODERSTROM.†

(From the *Physiological Laboratory of Cornell University Medical College, New York City.*)

(Received for publication, September 15, 1919.)

The experiments of this laboratory have demonstrated that a causative element of the great increase in heat production after meat ingestion is due to the stimulus provided by the acid products of protein metabolism. Thus, when glycocoll and alanine are given to a dog the metabolism increases greatly (1, 2). The increased metabolism is not due to the process of deamination or of urea formation because the administration of glutamic acid (1) or of asparagine (3) (the latter having the same NH_2 content as glycocoll) is without influence upon metabolism. The increased function of the kidney is without influence, for neither urea nor sodium chloride, when administered in aqueous solution, has any power to increase the basal metabolism (4). These experiments also exclude an increased osmotic exchange between the blood stream and the cells as a cause of the specific dynamic action.

It might be objected that glycocoll and alanine, which sometimes produce vomiting, cause an increased metabolism through gastric or intestinal irritation, but urea and salt solutions also sometimes produce vomiting; yet when they are retained by the stomach there is no rise in heat production after their administration. Benedict and Emmes (5) have shown that the adminis-

* An abstract of this work was published as, *Calorimétrie comparée de l'ingestion de viande, d'acide lactique et d'alanine chez l'animal* (Lusk, G., *Compt. rend. Acad.*, 1919, clxviii, 1012).

† Of the Russell Sage Institute of Pathology, in affiliation with the Second Medical Division of Bellevue Hospital.

tration of severe cathartics does not cause the heat production to increase. Furthermore, the increased metabolism is not due to the sudden availability of glycocoll or of alanine as providers of heat because a considerable increase in metabolism is achieved when these substances are administered in phlorhizin glycosuria, under which conditions they are completely converted into glucose and urea without the liberation of energy by oxidation (2). The amino-acids themselves are not stimuli to metabolism, for Rubner (6, *a*) has correctly shown that that quota of the ingested protein which is absorbed as amino-acids and deposited as new protein in the body exercises no *specific dynamic* action, in other words, does not raise the heat production.

There is a fundamental distinction between the heat production induced by protein and that brought about by carbohydrates. Thus, when a fasting dog is caused to perform a measured quantity of work, his heat production is the same as when he is given sugar in abundant supply. If the dog is given meat and caused to do the same amount of work as before his energy production will be raised above the basal level by the increment of the *specific dynamic* influence of the meat superimposed upon the increment of metabolism produced by the performance of the work (7).

In this fact lies the proof that the character of the cause of the increased heat production after giving meat and carbohydrate is essentially different.

That the primary metabolites are different is also indicated by the fact that, though fructose, when given in phlorhizin glycosuria, is converted into glucose and as such completely eliminated in the urine, the intermediary metabolites involved in this chemical transformation do not cause any increase in the metabolism of the dog (2).

In this connection it is of interest to note that the alkaline reserve of the blood falls after the administration of meat, which indicates the production of acid metabolites; this is not in evidence after the ingestion of a vegetarian diet (8). Atkinson and Lusk (3) have demonstrated that 200 cc. of 0.4 per cent of hydrochloric acid will increase the heat production in the dog from 20 to 21.25 calories per hour.

Furthermore, in phosphorus poisoning, a condition in which large quantities of lactic acid are produced, the heat production

is increased (9). It also appears probable that the rise in heat production in severe anemias is due to the pathological production of lactic acid from carbohydrates, which production may be assumed to take place only in the absence of an adequate oxygen supply to the cells (10).

These considerations naturally lead one to the conclusion that lactic acid itself, if given to a dog, might cause an increase in the heat production, just as ingested alanine does, a presumption which proved to be justified.

Methods.

The dog was given the "standard diet" at 5 p.m.; then either (1) the "basal metabolism" was determined by the calorimeter on the following morning, 18 hours or more after food ingestion, or (2) the material to be investigated was given by stomach tube during the morning and the dog was then placed in the calorimeter at an environmental temperature of 25 or 26°C. The results in the two instances could be compared (2).

EXPERIMENTAL.

It was found that when 10 cc. of *d-l*-lactic acid containing 8 gm. of lactic acid in solution were dissolved in 500 cc. of water, the dog invariably violently vomited the material. In one instance when 500 cc. of pure warm water were administered the dog regurgitated a considerable amount of the ingesta as though the mass were too great to be retained. However, when 500 cc. of water containing 2.5 gm. of Liebig's extract of meat were given the fluid was always retained. Whether this difference was due to the saline content or to the flavoring extractives in the Liebig's extract is unknown, but it is certain that beef broth is more readily retained in the stomach than plain water. When 2.5 gm. of Liebig's extract were added to the 1.6 per cent solution of lactic acid described above the fluid was retained in about half the instances. At one time, after quite frequently repeated administrations, the lactic acid solution was persistently vomited whenever given and the completion of the work was delayed until the dog's stomach had recovered from its abnormal irritability. When the lactic acid

was diluted with 400 cc. (instead of 500 cc.) of water the resulting 2 per cent solution was vomited. The solution was always given at a temperature of 38°C.

Series 1.

In this short series of experiments a comparison of the metabolism, after giving 8 gm. of lactic acid, with that found after giving 8 gm. of alanine was made as shown in Table I.

TABLE I.
Dog XVIII, Series 1.

No. of experiment.	Date.	State of nutrition.	Hours of experiment.	R. Q.	Calories per hour.		Increase over indirect basal (17.8 calories).
					In-direct.	Direct.	
	1918						
20	Dec. 26	Basal metabolism.	1	0.84	17.8	15.9	
21	" 27	Lactic acid, 8 gm.; Liebig's extract, 2.5 gm.; water, 500 cc.	2	0.93	20.9	21.0	+3.1
22	" 31	Alanine, 8 gm.; Liebig's extract, 2.5 gm.; water, 150 cc.	2	0.90	19.3	19.2	+1.5

The urinary nitrogen in Experiment 20 was 0.085 gm. per hour; in Experiment 25 it was 0.113 gm. per hour. In Experiment 22 it was assumed that the metabolism of body protein furnished the same 0.113 gm. of nitrogen per hour as in Experiment 25, that 70 per cent of the total amount of *d-l*-alanine was metabolized, and that of this 23 per cent was metabolized in the 2nd, and 21 per cent in the 3rd hour after the ingestion of the material (11).

Since lactic acid and glucose yield almost the same number of calories per gm. and both yield a respiratory quotient of 1.00, the calculation of the heat production by the indirect method after the usual manner is entirely justified.

The experiments (Table I) indicate that 8 gm. of lactic acid administered in 500 cc. of water increase the metabolism from 17.8 to 20.9 calories, an increment of 3.1 calories, whereas 8 gm. of alanine given in 150 cc. of water cause an increase of only 1.5

calories. Unfortunately, no more alanine was available. The discrepancy between the results was due to the difference in the quantity of water ingested, as appears in the second series of experiments.

Series 2.

It was stated by Rubner (6, *b*) and substantiated in this laboratory that the ingestion of a solution of Liebig's extract of meat

TABLE II.
Dog XVIII, Series 2.

No. of experiment.	Date.	State of nutritiop.	Hours of experiment.	R.Q.	Calories per hour.		Increase over indirect (17.4 calories).
					In-direct.	Direct.	
	<i>1919</i>						
34	Feb. 24	Meat, 1,080 gm.	2	0.80	34.0	34.1	16.6
37	" 28	Basal metabolism.	2	0.85	17.3	17.0	
39	Mar. 3	"	3	0.85	17.6	17.2	
40	" 4	Lactic acid, 8 gm.; Liebig's extract, 2.5 gm.; water, 500 cc.	3	0.88	19.4	18.3	2.0
41	" 5	Basal metabolism.	3	0.82	17.5	16.7	
42	" 11	Liebig's extract, 2.5 gm.; water, 500 cc.	3	0.80	18.5	17.6	1.1
43	" 12	Basal metabolism.	2	0.81	17.1	17.0	
44	" 13	Liebig's extract, 2.5 gm.; water, 500 cc.	3	0.78	18.2	17.5	0.8
45	" 14	Liebig's extract, 2.5 gm.; water, 150 cc.	3	0.84	17.0	16.9	
		Average.....			19.6	19.1	

was without influence upon the heat production. The increase in metabolism after giving meat extract to Dog XVIII, as shown in Table II, seemed at first difficult of interpretation. However, it was demonstrated by Experiment 45 that when the volume of the fluid administered was reduced from 500 cc. to 150 cc. the trustworthiness of the older experiments was confirmed, for there was then no rise in the heat production.

However, whenever the larger volume of fluid was given there was a rapid elimination of it by the kidney, as is shown in Table III.

It appears, therefore, that during the transportation of a large quantity of fluid through the system the heat production rises about 1 calorie per hour above the basal level (in Experiment 42, 1.1 calories, in Experiment 44, 0.8 calorie). A similar phenomenon must also occur in man in the exercise of the habit of excessive beer drinking.

The result of these investigations modifies the interpretation to be placed upon Experiments 21 and 40 in which lactic acid was administered in 500 cc. of water and increases of 3.1 and 2.0 calories per hour were noted, 1 calorie must be deducted in order to give the true increment of the increase due to lactic acid. This would indicate increases of 2.1 and 1.0 calories due to 8 gm. of

TABLE III.

Quantity of Urine Eliminated after the Ingestion of 500 Cc. of Water Containing 2.5 Gm. of Liebig's Extract.

No. of experiment.	Duration of period.		Total volume.	Volume per hour.
	<i>hr.</i>	<i>min.</i>	<i>cc.</i>	<i>cc.</i>
21	3	4	315	104
24	4	15	420	99
26	4	15	420	99
42	3	50	420	110
44	4		375	94
Average.....				101

lactic acid, which increases are to be compared with an increase of 1.5 calories due to the ingestion of 8 gm. of alanine (the latter having been given in a quantity of water which would not have increased the heat production).

Having determined that 8 gm. of lactic acid and the same amount of alanine produced comparable effects, it remained to investigate the influence of 8 gm. of glucose upon the heat production. The first two materials under favorable conditions may be completely converted into the third. If the reverse reaction takes place, and if 8 gm. of glucose are to any degree convertible into lactic acid or alanine, the metabolism would surely be increased. This problem is answered in the third series of experiments.

Series 3.

A dog received 8 gm. of glucose dissolved in 150 cc. of water and the results given in Table IV were obtained.

It is evident from these results that glucose given in this small amount is without influence upon metabolism. It had been previously known that the administration of 20 gm. of glucose to a dog was almost without influence upon the basal metabolism (1).

TABLE IV.
Dog XVIII, Series 3.

No. of experiment.	Date.	State of nutrition.	Hours of experiment.	R. Q.	Calories per hour.	
					In-direct.	Direct.
	1919					
57	May 9	Basal metabolism.	3	0.87	16.6	16.8
58	" 10	Glucose, 8 gm.; water, 150 cc.	2	0.91	15.8	15.1

CONCLUSIONS.

1. 2.5 gm. of Liebig's extract of beef dissolved in 500 cc. of water facilitate the retention by the stomach of this quantity of fluid by a dog weighing about 11 kilos.

2. It also prevents at times the regurgitation of 500 cc. of a 1.6 per cent solution of lactic acid.

3. The quantity of heat produced by the dog after the ingestion of 2.5 gm. of Liebig's extract of beef dissolved in 150 cc. of water is the same as that of the basal metabolism, but when the mass of fluid given reaches 500 cc. there is an increase of 1 calorie per hour, during which experimental period the quantity of urine eliminated averages about 100 cc.

4. After allowing for this factor, it appears that the increased heat production after giving 8 gm. of *d-l*-lactic acid is 2.1 and 1 calories and is comparable with that obtained after giving 8 gm. of *d-l*-alanine, 1.5 calories.

5. Following the administration of 8 gm. of glucose in 150 cc. of water there is no rise whatever in the basal metabolism. It seems therefore improbable that either lactic acid or alanine is normally produced in appreciable quantities from ingested glucose.

TABLE V.—G

Date	Experiment No.	Time	CO ₂	O	R Q	H ₂ O	Urine, basal N.	Calories.							
								Protein.	Alanine.	Non-protein.	Indirect.	Direct.			
1918			gm.	gm.		gm.	gm.								
Dec. 26	20	11.26-12.26	6.10	5.29	0.84	7.04	0.085	2.25			15.52	17.77	15.93		
"	27	21 11.30-12.30	8.24	6.07	0.99	7.93	(0.113)*	3.00			18.09	21.09	21.37		
		12.30- 1.30	7.35	6.13	0.87	7.30	(0.113)	3.00			17.77	20.77	20.68		
"	31	22 11.30-12.30	7.40	5.69	0.95	6.82	(0.113)	3.00	4.47		11.84	19.31	20.25		
		12.30- 1.30	6.80	5.78	0.85	6.82	(0.113)	3.00	4.08		12.21	19.29	18.11		
1919															
Feb. 24	34	12.45- 2.45	12.59	7.71	0.83	18.81	1.57	41.62			-7.40	34.22	35.72		
		1.45- 2.45	11.64	7.71	0.77	18.45	1.57	41.62			-7.95	33.67	33.51		
"	28	37 11.00-12.00	6.30	5.52	0.83		0.169	4.48			13.88	18.36	17.52		
		12.00- 1.00	5.47	4.85	0.86	6.50	0.169	4.48			11.75	16.23	16.37		
Mar. 3	39	11.00-12.00	6.39	5.48	0.85	6.88	0.154	4.08			14.27	18.35	17.34		
		12.00- 1.00	5.97	5.09	0.85	6.13	0.154	4.08			12.96	17.04	15.64		
		1.00- 2.00	6.05	5.19	0.85	6.28	0.154	4.08			13.28	17.36	18.67		
"	4	40 11.00-12.00	6.96	5.64	0.90		(0.154)	4.08			15.04	19.12	17.43		
		12.00- 1.00	7.26	5.81	0.91	7.05	(0.154)	4.08			15.74	19.78	17.92		
		1.00- 2.00	6.75	5.81	0.85	6.46	(0.154)	4.08			15.38	19.46	19.50		
"	5	41 11.00-12.00	5.89	4.95	0.86		0.145	3.84			12.78	16.62	16.67		
		12.00- 1.00	6.07	5.47	0.81	7.28	0.145	3.84			14.28	18.12	16.46		
		1.00- 2.00	5.94	5.39	0.80	6.83	0.145	3.84			13.98	17.82	16.99		
"	11	42 11.00-12.00	6.19	5.52	0.82		(0.145)	3.84			14.49	18.33	16.57		
		12.00- 1.00	5.81	5.46	0.77	6.77	(0.145)	3.84			14.09	17.93	17.32		
		1.00- 2.00	6.37	5.81	0.80	6.65	(0.145)	3.84			15.38	19.22	18.90		
"	12	43 11.00-12.00	5.78	5.06	0.83	6.14	(0.145)	3.84			13.00	16.84	17.14		
		12.00- 1.00	5.77	5.24	0.80	6.16	(0.145)	3.84			13.48	17.32	16.83		
"	13	44 11.00-12.00	6.11	5.26	0.84			3.84			13.74	17.58	18.43		
		12.00- 1.00	5.83	5.66	0.75	6.60	(0.145)	3.84			14.64	18.48	17.12		
		1.00- 2.00	5.96	5.71	0.76	6.61	(0.145)	3.84			14.85	18.69	16.98		

* Nitrogen values in parentheses are assumed from nearby records of the basal

Summary of Dog XVIII.

Morning weight.	Behavior of dog.	Food.
1.35	Quiet.	Basal metabolism.
1.31	Slight movement. Quiet.	8 gm. lactic acid; 2.5 gm. meat extract; 500 cc. water at 10.35 a.m.
1.26	Slight movement between the 2 hours.	8 gm. alanine; 2.5 gm. meat extract; 150 cc. water at 10.30 a.m.
2.07	Several movements. " "	1,080 gm. meat at 9 a.m.
1.95	Slight movement. Quiet.	Basal metabolism.
1.77	Slight movement. Quiet Slight movement.	Basal metabolism.
1.77	Quiet. " "	8 gm. lactic acid; 2.5 gm. meat extract; 500 cc. water at 10.17 a.m.
	" Slight movement. " "	Basal metabolism.
1.55	Quiet. " Slight movement.	2.5 gm. meat extract; 500 cc. water at 10.20 a.m.
1.50	Quiet. "	Basal metabolism.
1.53	" " "	2.5 gm. meat extract; 500 cc. water at 10.15 a.m.

Date.	Experiment No.	Time.	CO ₂	O ₂	R.Q.	H ₂ O	Urine, basal N.	Calories.					
								Protein.	Alanine.	Non-protein.	Indirect.	Direct.	
1919			<i>gm.</i>	<i>gm.</i>		<i>gm.</i>	<i>gm.</i>						
Mar. 14	45	11.30-12.30	5.82	4.83	0.88	5.65	(0.145)	3.84		12.41	16.25	16.37	
		12.30- 1.30	5.98	5.40	0.81	5.84	(0.145)	3.84		14.04	17.88	16.28	
		1.30- 2.30	5.93	5.05	0.85	5.34	(0.145)	3.84		13.07	16.91	18.12	
May 9	57	11.45-12.45	5.81	4.90	0.86		0.150	3.98		12.46	16.44	15.39	
		12.45- 1.45	5.90	4.57	0.94	7.54	0.150	3.98		11.64	15.62	17.00	
		1.45- 2.45	6.01	5.35	0.82	7.44	0.150	3.98		13.79	17.77	17.98	
" 10	58	11.00-12.00	5.70	4.58	0.91		0.155	4.11		11.40	15.51	13.76	
		12.00- 1.00	5.95	4.71	0.92	6.92	0.155	4.11		11.90	16.01	16.33	

The authors wish to acknowledge the assistance of Messrs. J. T. Sheridan and W. M. Stobbs in carrying out these experiments. Mr. Sheridan, a student of brilliant promise, died of the grippe while the experiments were in progress.

ded.

ing nt.	Behavior of dog.	Food.
55	Quiet.	2.5 gm. meat extract; 150 cc. water at 10.25 a.m.
	“	
	“	
80	“	Basal metabolism.
	“	
	Slight movement.	
67	Quiet.	8 gm. glucose; 150 cc. water at 10.24 a.m.
	“	

BIBLIOGRAPHY.

1. Lusk, G., *J. Biol. Chem.*, 1912-13, xiii, 155.
2. Lusk, G., *J. Biol. Chem.*, 1915, xx, 555.
3. Atkinson, H. V., and Lusk, G., *J. Biol. Chem.*, 1918, xxxvi, 415.
4. Lusk, G., *J. Biol. Chem.*, 1912-13, xiii, 27.
5. Benedict, F. G., and Emmes, L. E., *Am. J. Physiol.*, 1912, xxx, 197.
6. Rubner, M., (a) *Die Gesetze des Energieverbrauchs bei der Ernährung*, Leipzig and Vienna, 1902, 256; (b) *ibid.*, 66.
7. Anderson, R. J., and Lusk, G., *J. Biol. Chem.*, 1917, xxxii, 421.
8. Hasselbalch, K. A., *Biochem. Z.*, 1912, xlvi, 403.
9. Lusk, G., *Am. J. Physiol.*, 1907, xix, 461.
10. Lusk, G., *The elements of the science of nutrition*, Philadelphia and London, 3rd edition, 1917, 262.
11. Csonka, F. A., *J. Biol. Chem.*, 1915, xx, 539.

THE ANTISCORBUTIC VALUE OF THE BANANA.

By HOWARD B. LEWIS.

(From the Laboratory of Physiological Chemistry, University of Illinois, Urbana.)

(Received for publication, August 14, 1919.)

The nutritive value of the banana as determined by its adequacy for the growth or maintenance of albino rats has recently been the subject of investigation by Sugiura and Benedict (1). Rats maintained on banana alone failed to increase in size and died after periods of 16 to 80 days without marked loss in weight. It was suggested that the physical properties of the banana might not be favorable for the utilization of the food materials in the digestive tract of the rat. Further experiments in which the banana supplied only a part of the ration indicated that the banana was lacking in adequate amounts of protein and the water-soluble accessory (water-soluble B). For the cure of infantile scurvy the banana has been observed to have little antiscorbutic value (2), being decidedly inferior to the juice of the potato or orange. No studies of the antiscorbutic value of the banana in experimental scorbutus of the guinea pig have been reported.

Three cases of scurvy developed in the group of rats on an exclusive banana diet in the experiments of Sugiura and Benedict (1). No clinical or postmortem observations are recorded, however. The rat is not commonly considered to be susceptible to experimental scurvy, and McCollum and Pitz (3) have shown that normal growth and reproduction are possible in the rat on diets which produce scurvy in the guinea pig. Similar results have been obtained by Cohen and Mendel (4). Harden and Zilva believe that the antiscorbutic factor is necessary for the normal growth of the rat (5) even though those animals do not develop the typical lesions generally associated with the disease. Like conclusions have been reached more recently by Drummond (6). Tozer (7) has also reported that in guinea pigs on

diets deficient in factors other than the antiscorbutic principle, notably the fat-soluble accessory, histological study may reveal a condition closely resembling that present in experimental scurvy. In view of these facts and of the absence of detailed clinical or autopsy data, it may be considered questionable whether Benedict and Sugiura were dealing with typical experimental scurvy in their rats.

The present series of experiments is concerned with the value of the banana as an antiscorbutic in experimental scurvy of the guinea pig.

EXPERIMENTAL.

The experimental animals were young guinea pigs, for the most part about 300 gm. in weight. The greater number of the animals were purchased from a local dealer, who bred small numbers of them, and in whose pens the sanitary conditions were known to be excellent. In later experiments it became necessary to purchase some animals from wholesale dealers. In all cases, however, the animals were kept under careful observation in the laboratory on mixed diets until it was established that they were in good health. The animals were confined in cages about 30 by 18 inches in dimension which allowed a reasonable amount of exercise. These cages were cleaned daily, steamed out with live steam on alternate days, and once a week were washed out with a weak solution of phenol. Food consumption was determined by daily weighing of the uneaten portion. With the exception of a few days at the outset of the experiments, the containers for the drinking water were sterilized daily. The guinea pigs were weighed on alternate days.

The symptoms which were taken as a criterion of the onset of scurvy were those described by Chick, Hume, and Skelton (8), and by Cohen and Mendel (4). In all cases, the clinical data were checked up by postmortem examination, although it was not possible to secure histological examination of the tissues.

Bananas as the Sole Source of Food.—Sugiura and Benedict (1) have shown that the banana is deficient in protein and water-soluble B, and that adequate nutrition of the white rat is impossible on a diet consisting solely of bananas. Inasmuch as the nutritive requirements of the guinea pig have not been worked

out in such detail as have those of the white rat, it was considered desirable to study the influence of the banana diet on the growth of young guinea pigs. Two typical experiments are presented in Chart 1. Guinea Pig K with an average daily consumption of over 65 gm. of banana lost weight rapidly and died on the 26th day. No clinical signs of scurvy were evident and the postmortem examination of the animal revealed a marked condition of inanition, but no lesions of scurvy. Similar results

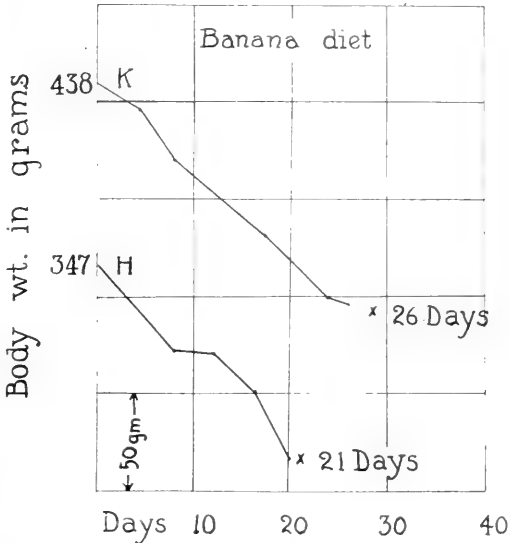

CHART 1. Guinea Pigs H and K received only ripe bananas, the average daily consumption being slightly over 50 and 65 gm. respectively. Both guinea pigs lost weight rapidly and died in 21 and 26 days respectively. No scorbutic symptoms were present at any time.

were obtained with Guinea Pig H whose average daily food consumption was somewhat less. The rapid decline in weight with no accompanying symptoms of scurvy was also shown in experiments (Chart 3) in which after a period of marked loss in weight the banana diet was supplemented by the addition of oatmeal. These results are similar to those reported by Sugiura and Benedict in experiments on white rats, although in the latter the decline in weight was less marked than in the present series.

Lack of the antiscorbutic factor can hardly be included in the list of the deficiencies of the banana as a foodstuff, since despite the marked malnutrition, as evidenced not only by failure of

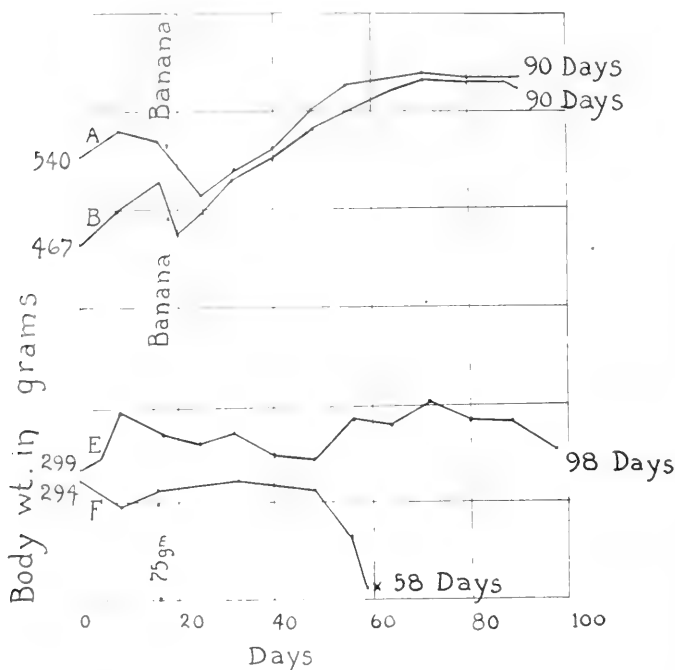

CHART 2. Guinea Pigs A and B received rolled oats *ad libitum* for 18 and 19 days respectively. At this point tenderness of the joints was evident and loss of weight was marked. Banana (35 gm.) added to the diet relieved the scorbutic symptoms and permitted slow growth. The animals were killed after 90 days. No signs of scurvy were observed on autopsy. Guinea Pigs E and F received rolled oats *ad libitum* and 35 and 25 gm. of banana respectively. No scorbutic symptoms developed. The oat intake of Guinea Pig F gradually diminished and the animal died after 58 days. Guinea Pig E was killed at the end of 98 days. Autopsy findings were normal in both cases.

growth, but even of maintenance on this diet, no scorbutic symptoms were observed.

Banana and Rolled Oats.—The early experiments of Holst and Frölich (9) and later investigations from other laboratories (3, 4,

10, and 11) have shown that guinea pigs on an exclusive cereal diet usually die in from 20 to 30 days with scorbutic symptoms. In Chart 2 and Table I are presented typical protocols of experiments in which banana supplemented the oatmeal diet. In the earlier

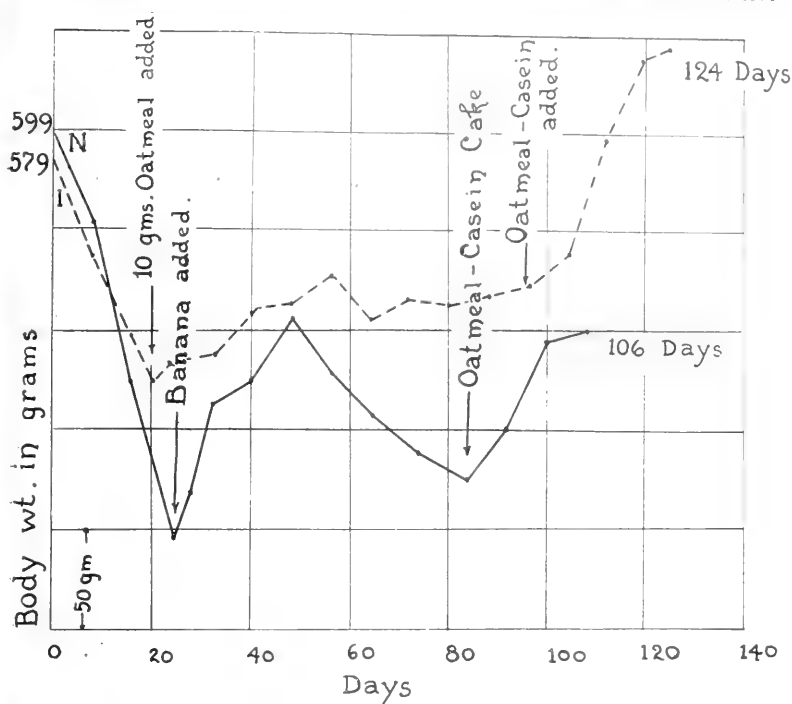

CHART 3. Guinea Pig I received an exclusive banana diet up to the 20th day; 10 gm. of oatmeal were then added until the 93rd day, after which the oatmeal-casein cake was fed in place of the oatmeal. The animal was free from clinical symptoms of scorbutus throughout the period of the experiment. Guinea Pig N received rolled oats only for 24 days. Soreness and slight enlargement of the joints developed about the 18th day. 30 gm. of banana as a supplement to the diet relieved the scorbutic symptoms although satisfactory growth was not made. When the oatmeal-casein cake was substituted for the rolled oats, rapid growth ensued.

part of the experiments bran was also added to the diet, but since the animals chose the rolled oats and left the bran unconsumed its use was discontinued. Provided the daily intake of banana could be maintained at 25 gm. or more, no scorbutic

TABLE I.

Guinea pig No.	Duration, <i>days</i>	Weight			Diet.	Notes.
		Initial:	Maximum:	Final.		
		<i>gm.</i>	<i>gm.</i>	<i>gm.</i>		
A	90	540	615	608	Oatmeal to 18th day; oatmeal and 35 gm. banana thereafter.	Marked loss in weight 12th to 18th day; slight gain to 60th day; no gain thereafter. Killed. No scurvy.
B	90	467	604	592	Oatmeal to 19th day; oatmeal and 35 gm. banana thereafter.	Marked decline in weight 14th to 20th day; gradual gain to 56th day. Killed. No scurvy.
C	26	687	693	483	Oatmeal.	Marked loss in weight after 18th day. Died. Scurvy.
D	34	320	331	238	Oatmeal and 10 to 15 gm. banana daily; banana eaten in small amounts only after 24th day.	Marked loss in weight after 20th day. Died. Severe scurvy.
E	98	295	358	317	Oatmeal and 35 gm. banana.	No growth; fluctuations in weight. Ate little food after 90th day. Killed. No scurvy.
F	58	290	299	213	Oatmeal and 25 gm. banana; diminished intake of oats toward end of experiment.	Progressive loss in weight with diminished food intake. Died. Inanition. No scurvy.
G	44	329	329	255	Oatmeal and 20 gm. banana.	Prolapse of rectum. Killed. Marked impaction of cecum. Mild scurvy.
H	21	347	364	247	Banana about 50 gm. daily.	Died. Inanition. No scurvy.
K	26	438	438	326	Banana about 65 gm. daily.	" " " "
I	124	579	641	641	Banana alone to 20th day; oatmeal and banana to 93rd day; oatmeal-cascin cake thereafter.	Marked loss in weight on banana diet; maintenance on banana-oat diet; vigorous growth on banana and oat cake.
M	73	754	754	416	Banana alone to 20th day; oatmeal and banana to end of experiment; little banana eaten last 2 weeks of experiment.	Died. Marked impaction of cecum. Severe scurvy.

TABLE I—Continued.

Guinea pig No.	Duration.	Weight.			Diet.	Notes.
		Initial	Maximum.	Final.		
	days	gm.	gm.	gm.		
N	106	599	643	505	Oatmeal to 24th day; oatmeal and 30 gm. banana to 75th day; oat cake and 30 gm. banana thereafter.	Loss in weight on oat diet; slight soreness of joints on 18th day; maintenance and slight growth on oat-banana diet; good growth on banana and oat cake. Killed. No scurvy.
S	86	235	431	423	Oatmeal and 25 gm. banana to 30th day; oat cake and 20 to 25 gm. banana thereafter.	Maintenance and slow growth on oat-banana diet; better growth on oat cake and banana. Killed. No scurvy.
T	48	308	308	187	Oatmeal to 12th day; oatmeal and 25 gm. banana to 30th day; oat cake thereafter.	Died. Marked clinical and postmortem symptoms of scurvy.
U	48	270	323	198	Oatmeal to 18th day; oatmeal and banana to 30th day; oat cake and banana to 36th day; oat cake alone thereafter.	Died. Severe scurvy.
V	86	272	491	491	Oatmeal to 18th day; oatmeal and banana to 29th; oat cake and 15 gm. banana thereafter.	Rapid gain in weight after addition of oat cake and banana. No scurvy.
W	86	276	477	477	Oatmeal to 20th day; oatmeal and banana to 28th day; oat cake and 25 gm. banana thereafter.	Loss in weight on oats alone; slight gain on banana-oat diet; rapid gain on oat cake and banana.
Y	24	352	352	223	Oat cake.	Rapid decline in weight after 16th day. Died. Scurvy.
Z	23	517	544	315	" "	Marked loss in weight after 14th day. Died. Mild scurvy.
10	81	230	500	495	Oat cake and 10 gm. banana.	Steady growth. In excellent condition at end of experiment.

TABLE I—*Concluded.*

Guinea pig No.	Duration.	Weight.			Diet.	Notes.
		Initial.	Maximum.	Final.		
		days	gm.	gm.		
11	83	238	335	332	Oat cake to 23rd day; oat cake and slightly less than 10 gm. banana thereafter; in last 10 days banana intake slightly above 10 gm.	Decline from 13th to 23rd day; increase to 39th day, decline to 49th day; steady gain thereafter. Soreness of joints from 30th to 67th day. In excellent condition at end of experiment.
12	72	258	433	433	Oat cake and 15 gm. banana.	Fair growth, no scurvy.
13	72	338	476	476	Oat cake and 15 gm. banana.	Fair growth; marked increase in weight during last 12 days. No scurvy.
14	72	273	518	518	Oat cake and 20 gm. banana.	General but somewhat irregular growth to 42nd day. Regular growth thereafter.
16	72	443	594	594	Oat cake and 20 gm. banana.	Fair growth. No scurvy.

symptoms were observed. Ingestion of quantities of banana less than this failed to give satisfactory protection against scurvy (Table I, Guinea Pigs D, G). Adult animals (Chart 2, Guinea Pigs A, B) maintained their weight or grew slowly, while younger animals (Chart 2, Guinea Pigs E, F) were barely able to maintain themselves, and in some cases showed marked decline in body weight, but no scorbutic symptoms, either clinical or postmortem. These results would seem to indicate that the banana is greatly inferior to most other fruits and vegetables as an antiscorbutic.

Inasmuch as the oat has been shown (3) to be deficient in the protein, inorganic salt, and fat-soluble A factors, and as the banana is also deficient in at least one of these same factors, it was felt that although the experiments had demonstrated a definite antiscorbutic value of the banana, the results could hardly be judged on the quantitative basis in view of the above mentioned deficiencies of the diet. A greater amount of the anti-

scorbutic principle may be requisite when the diet is not otherwise adequate to provide for normal growth and maintenance.

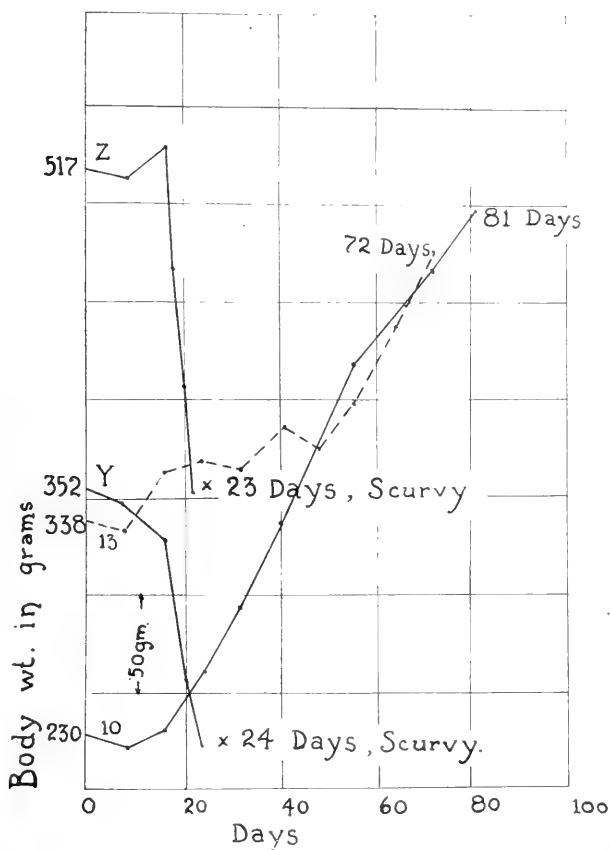

CHART 4. Guinea Pigs Y and Z were maintained on the oatmeal-casein cake without the addition of banana, and developed scurvy which resulted in death. Guinea Pigs 10 and 13 received the same diet with a supplement of 10 and 15 gm. of banana daily. The animals were in excellent condition throughout the course of the experiment.

Banana and Oatmeal-Casein Diet.—For the purpose of rendering the basal diet more nearly adequate for normal growth, the following ration was prepared.

Autoclaved rolled oats.....	500 gm.
Wheat bran.....	100 "
Purified casein.....	40 "
Raw milk.....	200 cc.
Calcium lactate.....	15 gm.
Sodium chloride.....	15 "
Distilled water.....	400 cc.

The oats were heated in an autoclave for 30 minutes at 120°. The dry ingredients were thoroughly mixed, the liquids added, the pasty mass was spread out in thin sheets, and dried at 75-80°. The resulting cake was relished by the animals so that little difficulty was experienced in securing a daily intake of 20 gm.

Guinea pigs maintained on this oatmeal cake developed scurvy as rapidly as on an exclusive oatmeal diet (Chart 4, also Guinea Pigs T, U, Table I). When this cake was supplemented by banana, not only was scurvy prevented, but rapid growth in young animals also occurred, growth which was in striking contrast to the results observed when banana supplemented an exclusive oat diet. This contrast is clearly shown in Chart 3. With this more complete diet protection against scurvy and normal growth were obtained with 10 to 15 gm. of banana. Thus Guinea Pig 10 (Chart 4) on a diet of 20 gm. of oat cake and 10 gm. of banana daily gained 265 gm. in 81 days, increasing in weight from 230 to 495 gm. Similar results were obtained with the other animals of this group (Guinea Pigs 10 to 16, Table I). It is evident that when supplementing a diet otherwise adequate, the banana has considerable value as an antiscorbutic, although its potency in this respect is not so great as that of the orange or potato.

SUMMARY.

1. Guinea pigs fed on an exclusive diet of bananas are unable to maintain their body weight and die in 20 to 30 days. Autopsy reveals a condition of marked inanition, but no lesions characteristic of scurvy.

2. Bananas in amounts greater than 25 gm. daily as a supplement to a diet of rolled oats prevent the onset of scurvy. Such a diet, however, does not permit normal growth in young animals. Less than 25 gm. of banana as a supplement to the oat diet does not protect against scurvy.

3. Scurvy can be readily produced experimentally on a diet of autoclaved rolled oats supplemented by bran, milk, casein, and inorganic salts. When such a diet is further supplemented by banana, 10 to 15 gm. will serve to protect against scurvy. Such a diet not only affords protection against scurvy but results in rapid growth of young guinea pigs.

4. These experiments suggest that a lower content of the anti-scorbutic principle may be sufficient to protect against scurvy if the diet is adequate in its content of the other essential dietary constituents.

BIBLIOGRAPHY.

1. Sugiura, K., and Benedict, S. R., *J. Biol. Chem.*, 1918, xxxvi, 171.
2. Hess, A. F., and Unger, L. J., *Am. J. Dis. Child.*, 1919, xvii, 221.
3. McCollum, E. V., and Pitz, W., *J. Biol. Chem.*, 1917, xxxi, 229.
4. Cohen, B., and Mendel, L. B., *J. Biol. Chem.*, 1918, xxxv, 425.
5. Harden, A., and Zilva, S. S., *Biochem. J.*, 1918, xii, 408.
6. Drummond, J. C., *Biochem. J.*, 1919, xiii, 77.
7. Tozer, F. M., in the appendix to Delf, E. M., *Biochem. J.*, 1918, xii, 416.
8. Chick, H., Hume, E. M., and Skelton, R. F., *Biochem. J.*, 1918, xii, 131.
9. Holst, A., and Fröhlich, T., *J. Hyg.*, 1907, vii, 634; *Z. Hyg.*, 1912, lxxii, 1; 1913, lxxv, 334.
10. Lewis, H. B., and Karr, W. G., *J. Biol. Chem.*, 1916-17, xxviii, 17.
11. Jackson, L., and Moore, J. J., *J. Infect. Dis.*, 1916, xix, 478.

THE DETERMINATION OF CARBON MONOXIDE IN BLOOD.

BY DONALD D. VAN SLYKE AND HARALD A. SALVESEN.

(From the Hospital of The Rockefeller Institute for Medical Research.)

(Received for publication, September 15, 1919.)

The determination of carbon monoxide in blood may be performed by gasometric, colorimetric, or spectrophotometric methods.

Previous gasometric methods have been laborious and most of them required special apparatus (as those of Gréchant, de Saint Martin, Nicloux, and others). The method employed by Zuntz and Plesch (1) seems to be the easiest. They determine the carbon monoxide in 1 cc. of blood, using ferricyanide to set the gases free (CO and O₂) and burn the CO to CO₂, which is absorbed by KOH. They calculate the amount of CO by the difference in pressure as in Haldane and Barcroft's method for blood gas analysis. According to the authors, the expulsion of the blood gases is finished after 1 hour.

The colorimetric method of Haldane (2) is based upon the fact that dilute carmine solutions have nearly the same color as dilute solutions of carbon monoxide hemoglobin. If it is known how much carmine has to be added to normal blood in order to give it the same color as blood completely saturated with carbon monoxide, and it is determined how much of the carmine must be added to normal blood to give it the color of the blood with the unknown content of CO, a simple calculation by proportion will give the degree of saturation with carbon monoxide.

This method seems to be very accurate in Haldane's hands, while others, like Krogh (3), and Zuntz and Plesch (1), have been unable to obtain good results with it. Plesch (4) has modified it, using a hemoglobin solution saturated with carbon monoxide instead of carmine for the titration.

104 Determination of Carbon Monoxide in Blood

Spectroscopic methods have been used by Hüfner and later by Hartridge (5). Krogh (6) has recently modified the method of the latter and used it for the determination of the oxygen capacity of very small amounts of blood; his method is still rather rough, but he hopes to make it more accurate with finer instruments.

An easy gasometric method seems still to be needed and we have worked out one which permits the determination of the carbon monoxide gasometrically in 2 cc. of blood in the course of 10 to 15 minutes. We have employed this method for the determination of the blood volume and for the study of the action of carbon monoxide on blood.

The Method.

The principle of our method is to set free the oxygen and carbon monoxide from their combination with hemoglobin in the blood by addition of ferricyanide and then to remove both gases with the help of a Torricellian vacuum in the Van Slyke apparatus for blood gas analysis. The oxygen is absorbed in the apparatus by alkaline pyrogallate and the volume of residual carbon monoxide is measured directly at atmospheric pressure, a correction being made for the small and constant amount of nitrogen gas physically dissolved by blood.

The procedure is, up to the time when the expelled gas is measured, exactly the same as that for the oxygen method described by Van Slyke (7), and it is therefore unnecessary to repeat it here; the same amount of blood and the same solutions are used, and only the shaking has to be continued a little longer before a constant reading is obtained. This takes about 2 to 3 minutes and is a little different for different species of blood; it probably depends upon the facility with which the blood is laked.

When the reading of the volume of the gas mixture, consisting of oxygen, carbon monoxide, and a little nitrogen, is constant, a solution of alkaline pyrogallate¹ is introduced into the cup of the apparatus, is covered by a thin layer of paraffin oil, and is allowed to flow slowly down the inner wall of the graduated part of the

¹ Prepared by dissolving 10 gm. of pyrogallie acid in 200 cc. of strong potassium hydroxide (160 gm. of KOH dissolved in 130 cc. of water).

apparatus. A little suction is produced during this part of the procedure by lowering the leveling bulb slightly.

The absorption of the oxygen is very rapid and is completed in less than 1 minute; the reading is taken and the pyrogallate solution introduced once more until a constant reading is obtained. The gas is then measured under barometric pressure in the same way as described by Van Slyke for carbon dioxide (8) and oxygen.

As the solution is very dark and it is a little difficult to get good readings of the meniscus, we have produced a new meniscus by letting a little water flow down after the pyrogallate solution; the water floats on the top of the fluid and one can get readings to about 0.002 cc. Instead of water a few drops of octyl alcohol may be used.

The apparatus is washed out twice with dilute ammonia solution after each determination.

Calculation.—The gas measured is reduced to standard conditions by multiplying by the factor $(0.999 - 0.0046 t) \times \frac{\text{Barometer}}{760}$, t being the temperature in °C. If 2 cc. of blood have been used, the values of this factor in Column 3 of Table I of Van Slyke's paper on oxygen² may be used, the result then being expressed in cc. of CO per 100 cc. of blood, when the nitrogen correction, 1.2 cc., is subtracted.³

EXPERIMENTAL.

Air was analyzed in the Van Slyke apparatus in order to find the best way of absorbing the oxygen. When the pyrogallate solution was introduced in the manner described above, the oxygen was absorbed in 30 seconds.

The method was tried in the following way. As the oxygen and the carbon monoxide replace each other in the combination with hemoglobin and the oxygen capacity equals the carbon monoxide capacity, blood with known percentages of carbon monoxide may be obtained by mixing different amounts of blood

² Van Slyke, D. D., *J. Biol. Chem.*, 1918, xxxiii, 130.

³ The nitrogen correction is 1.2 per cent, instead of the calculated value 0.9 per cent, when actually determined by Bohr and by ourselves.

106 Determination of Carbon Monoxide in Blood

saturated with carbon monoxide with blood saturated with air. By taking, for instance, one part of CO blood and four parts of O₂ blood, the analysis should give 20 per cent CO and 80 per cent O₂.

Table I shows the amounts of oxygen and carbon monoxide found by analysis and the amount calculated.

TABLE I.

No.	Blood used.	Found.			Calculated.			Kind of blood.
		Oxygen.	CO	Proportion of hemoglobin saturated with C.	Oxygen.	CO	Proportion of hemoglobin saturated with CO.	
	cc.	cc.	cc.	per cent	cc.	cc.	per cent	
1	2	0.212	0.206	50.7	0.209	0.209	50.0	Guinea pig.
2	2	0.208	0.210	49.8	0.209	0.209	50.0	Same blood.
3	2	0.118	0.240	32.9	0.117	0.238	33.3	Rabbit.
4	2	0.170	0.328	34.1	0.116	0.332	33.3	Ox.
5	2	0.088	0.250	26.0	0.084	0.252	25.0	Rabbit.
6		0.128	0.390	24.5	0.129	0.388	25.0	Ox.
7	2	0.068	0.240	22.1	0.062	0.246	20.0	Rabbit.
8	2	0.054	0.224	19.43	0.046	0.231	16.7	"
9	4	0.091	0.434	17.3	0.088	0.437	16.7	Same blood.

It is seen from Table I how closely the found values agree with those calculated, except in No. 8, where the discrepancy is 2.7 volumes per cent. By taking 4 cc. of the same blood instead of 2 cc., this error is brought down to 0.6 volume per cent. We therefore recommend the use of a little more blood, 3 or 4 cc. (and the correspondingly increased amount of ammonia), for analysis, if the percentage saturation of CO is very small and the actual amount of CO found in 2 cc. of blood is 0.05 cc. or less.

In two rather rough experiments, two guinea pigs were given illuminating gas under a bell jar until they fell unconscious. They were then taken out and blood was drawn by heart puncture for analysis. One of them died while the blood was being taken; the other recovered and behaved normally an hour afterwards.

Table II shows that a guinea pig can recover after carbon monoxide poisoning, even when the blood is 76.3 per cent saturated with carbon monoxide.

TABLE II.

	O ₂	CO	Satura- tion with CO.	Remarks.
	cc.	cc.	per cent	
Guinea Pig 1.....	0.115	0.353	75.4	Died during bleeding.
“ “ 2.....	0.080	0.258	76.3	Recovered.

SUMMARY.

A method is described for the determination of carbon monoxide in blood, the technique of which is exactly the same as that previously described by Van Slyke for the determination of oxygen, except that after the gases are extracted the oxygen is absorbed in the apparatus by introducing alkaline pyrogallate solution. The carbon monoxide remains and is measured directly at atmospheric pressure.

BIBLIOGRAPHY.

1. Zuntz, N., and Plesch, J., *Biochem. Z.*, 1908, xi, 47.
2. Haldane, J., *J. Physiol.*, 1895, xviii, 430. Douglas, C. G., and Haldane, J. S., *ibid.*, 1912-13, xlv, 309.
3. Krogh, A., *Skand. Arch. Physiol.*, 1910, xxiii, 218.
4. Plesch, J., *Z. exp. Path. u. Therap.*, 1909, vi, 407.
5. Hartridge, H., *J. Physiol.*, 1912, xlv, 1.
6. Krogh, A., *J. Physiol.*, 1919, lvi, 281.
7. Van Slyke, D. D., *J. Biol. Chem.*, 1918, xxxiii, 127.
8. Van Slyke, D. D., *J. Biol. Chem.*, 1917, xxx, 347.



THE DETERMINATION OF BLOOD VOLUME BY THE CARBON MONOXIDE METHOD.

By HARALD A. SALVESEN.

(From the Hospital of The Rockefeller Institute for Medical Research.)

(Received for publication, September 15, 1919.)

There is still much confusion regarding the exact value of the blood volume in human beings, though much work has been done in this field of investigation. Values for the blood volume for men are given, ranging from $\frac{1}{21}$ to $\frac{1}{8}$ of the body weight. These widely differing results have been obtained by the use of different methods.

There are one direct and several indirect methods for the determination of the blood volume.

Direct method.—Welcker (1) in 1854 was the first one to determine the blood volume by a method which still is regarded as the standard; he bled animals to death, washed out the vessels with water, and extracted the hemoglobin still remaining in the tissues by mincing the organs minus the bile and the content of the bowels, and placing them in water for several days. By comparing the hemoglobin content of the first blood and the blood washings and extracts brought together, he found the blood volumes of mammals to constitute $\frac{1}{13}$ of the body weight. The same value was obtained for human beings by Bischoff (2), who used this method on two criminals.

Welcker's method has been modified and improved by several investigators, but the general principle is the same as in 1854. The results obtained in animals with this method have differed because of incomplete washing and extraction, and the use of inexact methods for the hemoglobin determinations.

Indirect methods.—These methods must be used in experiments on living animals. There are various principles for the indirect determination of the blood volume. The best of them may be divided into two groups: (1) A known amount of an easily determinable substance, which is kept within the circulatory system for a sufficiently long time for thorough mixing, is introduced into the blood and the concentration of it deter-

mined. (2) The blood is either (a) diluted, or (b) concentrated in various ways, and the blood volume calculated from the variation in the content of hemoglobin or corpuscles.

Group 1. (a) Carbon Monoxide Method.—The principle of this method is to administer a certain amount of carbon monoxide gas to the individual, and then to determine the degree of saturation of the blood with CO or the actual amount of CO per unit of blood. It was first used by Gréhan and Quinquaud (3), and later by Haldane and Smith (4), Oerum (5), Douglas (6), Boycott and Douglas (7), and Plesch (8). (b) The dye method of Keith, Rowntree, and Geraghty (9) is the method most widely used for the present in clinical work. A dyestuff, vital red, is injected intravenously and determined colorimetrically in the blood. The relative amounts of plasma and corpuscles are determined by the hematocrit method. (c) The antitoxin method of von Behring (10) is based upon the observation that tetanus antitoxin remains in the circulation for a long period; a known amount is injected, and the concentration then determined in the blood. (d) The acacia method of Meek and Gasser (11) has been tried only in animals so far, and the experience is not large enough to judge of its utility. Acacia is injected and determined in the blood as furfuroolphloglucline.

Group 2. (a) Dilution Methods.—The only one of these methods which has withstood criticism is based upon the observation of Cohnstein and Zuntz (12) that isotonic sodium chloride solutions are kept in the circulation for a relatively long time, and diffuse very slowly out into the tissues; this is utilized for the determination of the blood volume, the red cells being counted before and after infusion. Plesch (8) seems to have developed this method to further exactness by determining the hemoglobin instead of the cells with the help of his chromophotometer. As the variations in the cell or hemoglobin content obtained by dilution hardly exceed 10 per cent, the exactness of the method evidently depends on how accurately these constituents of the blood can be determined.

(b) *Concentration Methods.*—The method of Tarchanoff (13), who determined the hemoglobin before and after a steam bath and the decrease in weight through loss of water, and calculated the blood volume from these two factors, has been justly criticized and cannot be relied upon, as the water may be derived from other sources in the body than the blood.

Quincke (14) transfused blood with a certain amount of red corpuscles to two anemic patients and calculated the blood volume from the increase in the red count. Lindeman (15) uses the same principle. These methods can only be used in anemia.

Of these methods only three are of practical value for physiological and clinical purposes; they are the carbon monoxide method, the infusion method of Cohnstein and Zuntz, and the vital red method.

The results obtained by these methods vary. In animals, both the carbon monoxide method and the infusion method have given nearly the same values as the Weleker method; Gréhan and Quinquaud (3) found in nine dogs values from $\frac{1}{11}$ to $\frac{1}{13.8}$ of the body weight with the CO method,

which correspond to Welcker's own results in dogs. Douglas (6) found a close agreement between the CO method and the bleeding method in five rabbits; Boycott and Douglas (7), repeating the experiments later, found a little higher value with the CO method (2 per cent). Plesch (8), in dogs, tried subsequently the CO, the infusion, and the bleeding method, and the results were uniform. The vital red method has never been checked up by the Welcker method as far as can be seen from the literature.

In human beings the results are widely different. Bischoff's values, $\frac{1}{13}$ of the body weight, were regarded as the standard until Haldane and Smith (4), with the CO method and carmine titration, in fourteen normal men found $\frac{1}{21}$, the highest value being $\frac{1}{16}$ and the lowest $\frac{1}{30}$ (in a very fat man). Oerum (5), using the same technique, found in men $\frac{1}{19.2}$, and in women $\frac{1}{21.8}$. Plesch (8), using a gasometric method for the CO determination in four men, found the average ratio $\frac{1}{17.9}$; also in five persons, some of whom were reported to be fat, he determined the blood volume with the infusion method and found $\frac{1}{19.1}$. Bischoff's results, therefore, seem to be too high, inasmuch as the two criminals were hardly normal individuals, one at least suffering from scurvy. The method used is also open to criticism.

Douglas (16), in 1910, made a series of determinations with the CO method on himself and another subject with Haldane's technique, but waited a longer time before he took the blood sample for analysis. These results show a mean value of $\frac{1}{13.9}$ for his own and $\frac{1}{12.5}$ for the other subject, values more in accordance with those of Bischoff. He found errors in Haldane and Smith's determinations due to incomplete mixing of the blood, as the blood sample was taken too early after the breathing of the carbon monoxide.

In 1915 Keith, Rowntree, and Geraghty (9), with their vital red method, found still higher values, the mean in normal men being $\frac{1}{11.8}$ of the weight. This method has never been controlled by the Welcker method as far as can be seen, but the authors show its reliability toward relative changes by drawing a certain amount of blood and finding a corresponding drop in the blood volume.

It may be seen from this review of the literature how uncertain is our knowledge of the blood volume in human beings. Since the carbon monoxide method in animals has given satisfactory results as compared with the standard method of Welcker, and

in human beings the results obtained by the various investigators have differed widely, it seems worth while to make further investigations in this field, especially since the technique used before has been rather difficult.

It seems certain, according to Douglas, that Haldane and Smith's figures are too small, and so must be the figures of Oerum, as he used the same technique. There remain, therefore, only the determinations of Plesch in four persons, giving the average of $\frac{1}{17.9}$ and those of Douglas, on himself and another man, giving the values of $\frac{1}{13.9}$ and $\frac{1}{12.5}$ of the body weight.

The carbon monoxide method has been criticized by Dreyer (17) and his coworkers, who, in rabbits, used Haldane and Smith's technique, and got so much divergence in the figures that they concluded it could not be used in its present form. They therefore determined the blood volume by injecting in rabbits' blood a known amount of agglutinin, determined the percentage in the serum, then washed out the circulation, and determined the percentage of agglutinin in the washing. They claim the blood volume to be a function of the surface area, so that, for instance, smaller rabbits have a relatively higher blood volume than the larger ones.

The adverse criticism of the carbon monoxide method may be due to the difficulty of the technique, as the carmine titration of Haldane requires long training and a highly developed color sense. All the carbon monoxide determinations in the present paper are performed with the help of the gasometric method, described in the preceding paper, which makes the whole technique much simpler and fitted for general use.

Blood Volume Determinations in Animals.

The results of numerous determinations of Boycott and Douglas (7) show that rabbits' blood constitutes from $\frac{1}{22}$ to $\frac{1}{18.1}$ of the body weight, as determined both with the carbon monoxide and the washing out method. The average of 52 rabbits with the washing out method was $\frac{1}{20.9}$, or 4.77 cc. of blood per 100

gm. of body weight, while the carbon monoxide method (with the carmine titration) gave a little higher result, $\frac{1}{18.1}$ or 5.5 cc. per 100 gm.

Methods.

The arrangement used was that described by Douglas (6). It is therefore unnecessary to repeat it here.

The principle is to let the rabbit breathe into a closed system which is supplied with arrangements for removing the carbonic acid and renewing the oxygen. A measured amount of carbon monoxide is introduced into the apparatus, and 10 minutes after the entire amount is given a sample of blood is drawn from the ear vein and analyzed for carbon monoxide. At the same time a sample of the air in the chamber is taken for determination of the O_2 , CO_2 , and CO . The blood volume is calculated from the amount of carbon monoxide absorbed by the animal and the concentration of it in the blood. As in Douglas' experiments, a tube connected with a bell jar, partly immersed in a glass of water, was introduced into the respiratory chamber, and served as an indicator of the pressure in the apparatus. While the air sample was drawn, the oxygen current was cut off and the water allowed to rise in the bell jar by raising the glass in order to compensate for the negative pressure produced by the sucking out of the air.

The capacity of the apparatus (the chamber and the air in the rubber tubing, the pump, and the bell jar) was 750 cc., a little larger than that of the apparatus employed by Douglas (6), and Boycott and Douglas (7).

The carbon monoxide was prepared by heating oxalic acid and concentrated sulfuric acid, and the gas was collected over water made alkaline with sodium hydroxide, with which the gas was shaken in order to get rid of the CO_2 . The gas was analyzed every 2nd day by shaking it in a Hempel pipette with cuprous chloride solution, which absorbs the carbon monoxide and O_2 , and from the amount of nitrogen left the air content of the gas was calculated. The gas first evolved was discarded. The carbon monoxide content of the rest was 95 to 98 per cent.

The carbon monoxide in the blood was determined by the method described in the preceding paper, the blood, 4.5 cc. in

all, being drawn from the ear vein without stasis and kept under paraffin oil; 2 cc. were used for each analysis. The hemoglobin was determined by the Palmer method (18). The air in the chamber was analyzed for O_2 and CO_2 in the Haldane-Henderson apparatus.

The determination of the carbon monoxide left in the chamber could not be made by gasometric methods, and the method of Haldane (19) was employed, the principle of which is to shake the carbon monoxide-containing air with blood, to estimate colorimetrically the percentage of saturation of the blood with carbon monoxide, and deduce from this value, and the percentage of O_2 present, the percentage of carbon monoxide in the air. As bloods of different species and also of different individuals show different dissociation curves for the carbon monoxide hemoglobin, as shown by Krogh (20) and Haldane (21), blood from a single sheep was used, in which the dissociation curve was previously determined (preceding paper). The dissociation curve is a hyperbola of the formula

$$\frac{(\text{O}_2 \text{ percentage in air})}{(\text{CO percentage in air})} \times \frac{\text{Hb CO}}{\text{Hb O}_2} = K$$

In the blood used $K = 179$ at 24° .

For the determination of the dissociation curve of the blood of our sheep, 5 cc. samples of the blood were rotated in bottles of known capacity (approximately 1 liter), filled with air plus known amounts of carbon monoxide. The blood was first placed in the bottle, which was then closed by a stopper containing a three-way capillary cock. A known volume (1 to 4 cc.) of analyzed CO gas was then forced in from a micro-gas-burette, in which the volume delivered could be read over mercury to within 0.002 cc. The tubes of the cock were filled with the CO before the measured amount was admitted into the bottle, so that errors due to dead space were avoided. The bottle with the blood and gas mixture was rotated for 2 hours at 24°C . Trial showed that equilibrium was obtained in this time. Samples of 2 cc. of blood were then withdrawn and used for the determination of O_2 and CO as described in the foregoing paper. The volume of CO taken up by the 5 cc. of blood was subtracted from the volume of CO originally added, in order to estimate the amount left in the gas

phase. The oxygen concentration remained that of atmospheric air.

The results obtained in four determinations are shown in the curve of Fig. 1. The curve is the hyperbola plotted from the formula, with 179 taken as the value of K ; the crosses represent the results experimentally obtained.

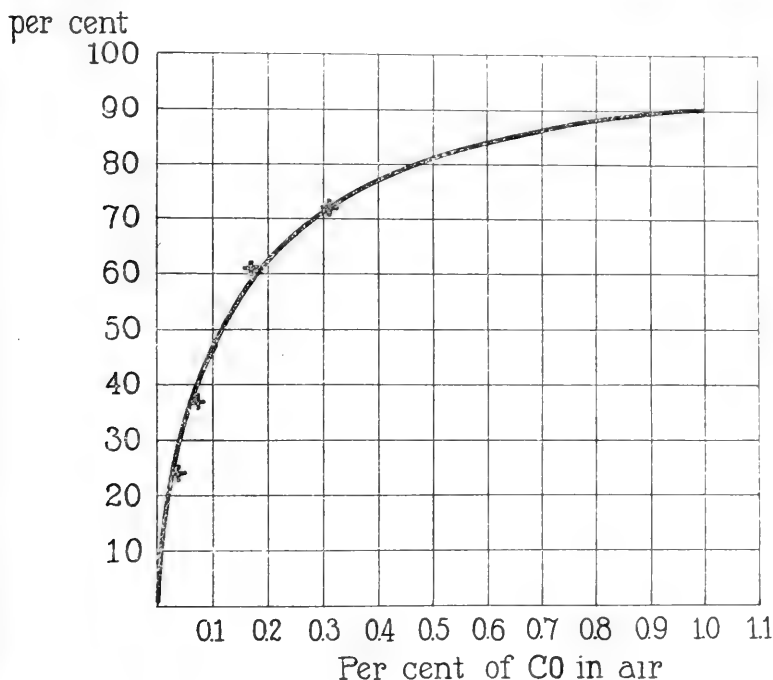

FIG. 1. The curve is the hyperbola plotted from the formula, with 179 taken as the value of K ; the crosses represent the results experimentally obtained.

The value of K being known, small percentages of CO in air could be ascertained by shaking the latter with a known volume of the blood and determining the Hb O₂ and Hb CO, the calculation being *per cent CO in air* = $\frac{21.9}{179} \times \frac{\text{Hb CO}}{\text{Hb O}_2}$. In calculating the actual percentage of CO in the gas-sampling tube allowance was made for the amount of CO taken up by the blood with which the air was shaken. The colorimetric determination was

made by the method employed by Plesch (8), which is very simple and which gave fairly good results when used on blood with known percentages of CO. The principle is: Three samples of the same blood are saturated; No. 1 with air, No. 2 with CO, and No. 3 with the air containing the unknown percentage of CO. 0.05 cc. of each sample is diluted with 10 cc. of a 1 per cent solution of Na_2CO_3 in each of three small test-tubes of equal bore. No. 2 is added to No. 1 until the color is the same as in No. 3. If, for instance, equal color is obtained by adding 2.5 cc. of No. 2 to 5 cc. of No. 1, then the degree of saturation is $\frac{2.5}{2.5+5} = 33.3$ per cent.

Results.

In fourteen rabbits taken from the stock the blood volume was determined. In two of the female rabbits the values obtained were much higher than the average, and they later proved to be pregnant. They were placed in a separate group and the blood volume determined again, post partum. In some of the other rabbits the blood volume also was determined twice. The results are given in Tables I to V.

TABLE I.
Normal Male Rabbits.

Rabbit No.	Date.	Weight.	Hemoglobin.	Blood volume.	Relation to body weight.	Cc. per 100 gm.
	1919	gm.	per cent	cc.		
77	July 3	1,500	(?)*	79.4	$\frac{1}{19.1}$	5.20
93	" 8	1,900	(?)*	95.7	$\frac{1}{19.9}$	5.02
89	" 10	1,600	93.4	80.9	$\frac{1}{19.8}$	5.05
80	" 10	2,250	94.3	107.1	$\frac{1}{21}$	4.76
99	" 14	3,010	86.2	146.9	$\frac{1}{20.5}$	4.88
82	" 14	2,200	87.7	115.4	$\frac{1}{19.06}$	5.25
98	" 15	2,200	93.4	111.1	$\frac{1}{19.8}$	5.05

* Determinations lost because of an incorrect hemoglobin standard.

TABLE II.
Normal Female Rabbits.

Rabbit No.	Date.	Weight.	Hemoglobin.	Blood volume.	Relation to body weight.	Cc. per 100 gm.
	1919	gm.	per cent	cc.		
66	July 2	2,300	(?)*	122.2	$\frac{1}{18.8}$	5.30
76	" 7	1,250	83.3	50.8	$\frac{1}{24.6}$	4.06
88	" 9	1,960	86.2	100.6	$\frac{1}{19.4}$	5.14
83	" 11	2,630	76.9	129.2	$\frac{1}{20.3}$	4.93
87	" 11	2,320	51.4	127.5	$\frac{1}{18.2}$	5.49

* Determination lost because of an incorrect standard.

TABLE III.
Repeated Determinations.
Male Rabbits.

Rabbit No.	Date.	Weight.	Hemoglobin.	Total oxygen capacity.	Blood volume.	Ratio.	Cc. per 100 gm.
	1919	gm.	per cent	cc.	cc.		
93	July 8	1,900	(?)*	(?)*	95.7	$\frac{1}{19.9}$	5.02
	" 21	1,940	59.3	10.14	92.4	$\frac{1}{21}$	4.76
77	" 3	1,500	(?)*	(?)*	79.4	$\frac{1}{19.1}$	5.20
	" 18	1,540	75.0	13.87	72.9	$\frac{1}{21.1}$	4.74
80	" 10	2,250	94.3	18.68	107.1	$\frac{1}{21.1}$	4.76
	" 17	2,270	90.9	17.54	102.1	$\frac{1}{22.2}$	4.50
99	" 14	3,010	86.2	21.08	146.9	$\frac{1}{20.5}$	4.88
	" 18	3,070	74.1	22.33	162.1	$\frac{1}{18.9}$	5.29

* Determination lost because of an incorrect standard.

TABLE IV.
Repeated Determinations.
Female Rabbits.

Rabbit No.	Date.	Weight.	Hemoglobin.	Total oxygen capacity.	Blood volume.	Ratio.	Cc. per 100 gm.
	1919	gm.	per cent	cc.	cc.		
76	July 7	1,250	83.3	7.83	50.8	$\frac{1}{24.6}$	4.06
	" 15	1,350	66.6	8.30	66.8	$\frac{1}{20.2}$	4.95
81	" 11	2,320	51.4	12.12	127.5	$\frac{1}{18.2}$	5.49
	" 17	2,300	47.4	11.44	129.0	$\frac{1}{17.8}$	5.62

TABLE V.
Blood Volume in Pregnant Rabbits before and after Term.

Rabbit No.	Determination made.	Date.	Weight.	Hemoglobin.	Total oxygen capacity.	Blood volume.	Ratio.	Cc. per 100 gm.	Remarks.
		1919	gm.	per cent	cc.	cc.			
65	Before.	July 8	2,650	69.4	22.86	177.3	$\frac{1}{14.9}$	6.70	Young ones, July 15.
	6 days post partum.	" 21	2,290	76.3	15.24	108.3	$\frac{1}{19.4}$	5.14	
87	Before.	" 9	2,560	94.0	24.29	141.1	$\frac{1}{18.1}$	5.52	Young ones, July 20.
	"	" 16	2,570	74.4	22.2	161.3	$\frac{1}{15.3}$	6.54	
	11 days after.	" 31	2,350	76.3	15.59	110.5	$\frac{1}{21.2}$	4.72	

In Tables III and IV is introduced a column, "total oxygen capacity," the figures in which indicate all the oxygen with which the blood is able to combine, calculated from the blood volume and the hemoglobin percentage. In our hemoglobin standard 100 per cent equals 18.5 volumes per cent of O₂.

DISCUSSION.

The results are expressed in parts of the crude body weight, though this may vary for various causes, such as food intake, content of bowels, etc. The average value for the blood volume in seven male rabbits (eleven determinations, Tables I and III) is $\frac{1}{20.21}$ of the body weight, or 4.95 cc. per 100 gm. The average in five non-pregnant female rabbits (seven determinations, Tables II and IV) is $\frac{1}{19.9}$ of the weight, or 5.02 cc. per 100 gm. If the two determinations from Table V in rabbits post partum are added, the mean for all seven females is the same, $\frac{1}{19.99}$, or 5.0 cc. per 100 gm. The results are in accordance with those obtained by Boycott (7) and coworkers with the washing out method.

The repeated determinations in Tables III and IV show a fairly close agreement in some of the rabbits, while in Rabbits 99 and 76 there is a considerable difference. But the total oxygen capacity is nearly constant in these two rabbits. Rabbit 76 had increased in weight from 1,250 to 1,350 gm., and to get comparable values the oxygen capacity in the first determination has to be multiplied by $\frac{1,350}{1,250} = 1.08$, and this gives the value of 8.46 cc. which is very close to the value found the second time, 8.30 cc. The same phenomenon is seen in the pregnant rabbit, No. 87, of Table V. The two determinations before partus gave $\frac{1}{18.1}$ and $\frac{1}{15.3}$ of the weight, which is a large increase in the blood volume. The hemoglobin concentration dropped, however, so that the oxygen capacity of the total blood supply of the animal remained constant, the blood merely having become diluted in the interval between determinations. About a week after partus the blood volume was again normal.

The blood volume of the rabbit, therefore, seems to be able to change normally, probably in the way that fluid passes in and out through the capillaries, a phenomenon in analogy with what has been observed in human beings in shock. Rabbits 99 (Table III), 76 (Table IV), and 87 (Table V), in which these changes in

the blood volume and constancy of the total oxygen capacity were so marked that they cannot be due to experimental error, show the smallest volume the first time, when they were unexperienced and scared when put into the apparatus, and a larger volume the second time, when they were used to the procedure. The material is too small, however, to draw any conclusion on this point, but Douglas has observed the same phenomenon of changes in the volume and constancy of oxygen capacity.

Table V shows the well known fact that pregnant animals have a larger blood volume absolutely and relatively than non-pregnant. A week post partum the blood volume is restored to the normal value.

Blood Volume Determinations in Human Beings.

The arrangement of apparatus was nearly the same as that described by Haldane and Smith (4), except that an ordinary Wolff bottle, filled with sticks of potassium hydroxide,¹ was used for the absorption of the carbonic acid, as seen in Fig. 2, and the experiments lasted longer, the subjects breathing for 10 to 15 minutes after the entire amount of carbon monoxide was given. The oxygen was supplied from a cylinder as rapidly as was necessary in order to keep the amount of gas in the bag approximately constant. The estimation of the relative volume of air in the bag was facilitated by placing the bag horizontally with a scale behind it as an indicator of the degree of filling.

The apparatus was filled with carbon monoxide to the three-way stop-cock before the experiment was started. The volume of the connecting parts and the bag, filled with air to the mark, was 3,700 cc. For the calculation of the amount of carbon monoxide left the volume of the lungs must be added; this is about 3,000 cc., and the total volume of the air in which the carbon monoxide was distributed thus was 6,700 cc.

The blood, being assumed to constitute not less than $\frac{1}{19}$ of the body weight, the amount of carbon monoxide given to the sub-

¹ Potassium hydroxide was used because of the high solubility of the potassium carbonate formed during the experiment; this carbonate was washed out by rinsing the sticks with water now and then.

ject was so calculated that the saturation of the blood with carbon monoxide would not exceed 20 to 25 per cent. For instance, with the body weight 70 kilos, hemoglobin 120 per cent, blood volume at least $\frac{70}{19} = 3.7$ liters, and as 100 per cent hemoglobin =

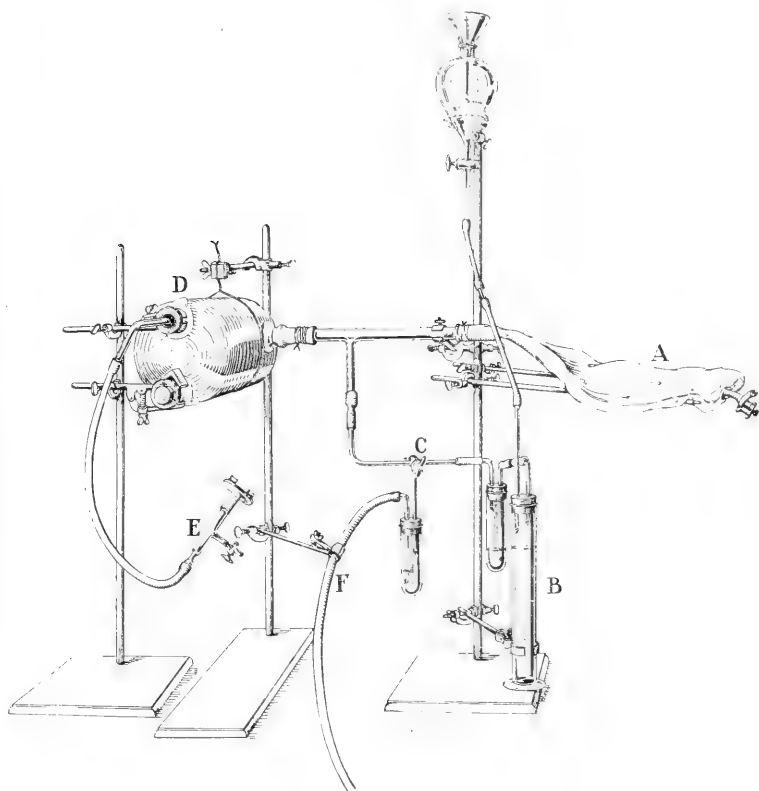

FIG. 2. A, rubber bag, B, volumetric measuring cylinder for carbon monoxide, C, three-way stop-cock, D, Wolff bottle for removing the carbon dioxide, E, mouthpiece, F, tubing connected with the oxygen cylinder.

18.5 volumes per cent of O_2 capacity, the capacity in this case would be 22.2 cc. per 100 cc. of blood; per 3,700 cc. it accordingly would be 821.4 cc. One, therefore, could safely give 164 cc. of carbon monoxide reduced to standard conditions (760 mm. and 0°).

The blood sample was drawn without stasis from the arm vein

and kept under paraffin oil. The carbon monoxide was determined by the method of Van Slyke and Salvesen,² 3 cc. being used for each determination, as the carbon monoxide content of the blood is rather small in these experiments.

The air in the bag was analyzed for oxygen, carbon dioxide, and carbon monoxide after each experiment, as in the animal experiments. In all except the last experiment the amount of carbon monoxide left was about 2 cc.: 1.47, 1.902, 2.53, 1.832, 1.96; average 1.938 cc. In the last experiment it was 4.42 cc., but in this case more oxygen was given than necessary, and the oxygen content of the bag was 33 per cent. This probably accounts for the slower absorption of the carbon monoxide, the dissociation curve of the carbon monoxide-hemoglobin being depressed when the oxygen percentage increases. If the experiments, therefore, are always performed in the same way, the amount of carbon monoxide left is constant, and if the apparatus has the same capacity as used in the present experiments, the correction which must be subtracted is 2 cc. The experiments done in this way are much simpler, the only determination which must be done being that of the carbon monoxide in the blood.

Six healthy individuals were examined, ranging in age from 23 to 37 years. The material was rather uniform as all were young people without any adipositas. The results are given in Table VI.

The average blood volume found was 3,888 cc., constituting $\frac{1}{16.8}$ of the weight, or 5.95 cc. per 100 gm. The extremes are $\frac{1}{14.3}$ and $\frac{1}{19.08}$. The largest volumes were found in Nos. 1 and 6, both of whom are tall and slim, especially No. 6 who is abnormally thin, and weighs much less than would correspond with his height. In No. 1 two determinations were made and the difference found is only 7 cc. of blood.

The mean value, then, is a little larger than that of Plesch, who found $\frac{1}{17.9}$ and smaller than that of Douglas, who found in two persons $\frac{1}{13.9}$ and $\frac{1}{12.5}$.

² Van Slyke, D. D., and Salvesen, H. A., *J. Biol. Chem.*, 1919, xl, 103.

All the persons experimented on felt comfortable, and did not have any disagreeable sensations. The breathing was easy, and even a certain degree of dyspnea is not likely to interfere with the use of this method in pathological cases. Former investigators

TABLE VI.
Blood Determinations in Human Beings.

No.	Date.	Name.	Age.		Dura- tion.	Hemo- glo- bin.	Blood volume.		
			Yrs.	Mo.			cc.	Ratio.	Cc. per 100 gm.
	1919		Yrs.	Mo.	Min.	Per cent			
1	July 28	Dr. H. S.	30	68.8	32	114	4,594	$\frac{1}{14.97}$	6.67
	Aug. 1	"		68.8	35	114	4,601	$\frac{1}{14.82}$	6.74
2	July 29	Mr. A. S.	26	60.9	28	124.9	3,464	$\frac{1}{17.6}$	5.68
3	" 29	Dr. H. A.	36	66.4	23	118	3,479	$\frac{1}{19.08}$	5.23
4	" 30	Dr. V. S.	37	72.7	27	113	3,877	$\frac{1}{18.7}$	5.35
5	" 31	Dr. J. T.	28	61	23	114	3,429	$\frac{1}{17.7}$	5.65
6	Aug. 1	Mr. R. T.	23	62.7	22	116	4,380	$\frac{1}{14.3}$	6.99
Average.				65.4			3,888	$\frac{1}{16.8}$	5.95

have used the carbon monoxide method in heart, kidney, and anemic cases without any difficulties.

It is hoped that the blood volume method with the easy technique for the carbon monoxide determination will be of more practical value than before.

SUMMARY.

Determinations of the blood volume by the carbon monoxide method with the simple technique previously described for the blood analysis have been made in fourteen rabbits and six normal men. Eleven determinations in seven male rabbits show an average blood volume of $\frac{1}{20.21}$ of the body weight, or 4.95 cc. per 100 gm. Nine determinations in five non-pregnant female rabbits show an average of $\frac{1}{19.99}$, or 5.0 cc. per 100 gm.

In two pregnant rabbits the blood volume was largely increased, absolutely and relatively; about a week post partum it was restored to normal again.

The blood volume of rabbits may change from time to time, but the total oxygen capacity remains constant.

Seven determinations in six healthy men show an average of $\frac{1}{16.8}$ of the body weight, or 5.95 cc. per 100 gm.

The author wishes to express his thanks to Dr. Donald D. Van Slyke on whose initiative this work was undertaken, and to Mr. Arthur H. Smith for his technical assistance during the experiments.

BIBLIOGRAPHY.

1. Welcker, H., Prager Vierteljahrschrift, 1854, iv, 154; *Z. ration. Med.*, 1858, iv, 145.
2. Bischoff, T. L. W., *Z. wissenschaft. Zool.*, 1856, vii, 331; 1858, ix, 65.
3. Gréhan and Quinquaud, E., *Compt. rend. Acad.*, 1882, xciv, 1450.
4. Haldane, J., and Smith, J. L., *J. Physiol.*, 1899-1900, xxv, 331.
5. Oerum, H. P. T., *Deutsch. Arch. Klin. Med.*, 1908, xciii, 356; *Festschrift Olaf Hammarsten*, Upsala, 1906.
6. Douglas, C. G., *J. Physiol.*, 1905-06, xxxiii, 493.
7. Boycott, A. E., and Douglas, C. G., *J. Path. and Bacteriol.*, 1909, xiii, 256; 1912-13, xvi, 485.
8. Plesch, J., *Z. exp. Path. u. Therap.*, 1909, vi, 380.
9. Keith, N. M., Rowntree, L. G., and Geraghty, J. T., *Arch. Int. Med.*, 1915, xvi, 517.
10. von Behring, *Münch med. Woch.*, 1911, lviii, 655.
11. Meck, W. J., and Gasser, H. S., *Am. J. Physiol.*, 1918-19, xlvii, 302.

12. Cohnstein, J., and Zuntz, N., *Arch. ges. Physiol.*, 1888, xlii, 303.
13. Tarchanoff, J. R., *Arch. ges. Physiol.*, 1880, xxiii, 548; 1881, xxiv, 525.
14. Quincke, H., *Deutsch. Arch. klin. Med.*, 1877, xx, 27.
15. Lindeman, E., *J. Am. Med. Assn.*, 1918, lxx, 1209.
16. Douglas, C. G., *J. Physiol.*, 1910, xl, 472.
17. Dreyer, G., and Ray, W., *J. Path. and Bacteriol.*, 1909, xiii, 344; 1912-13, xvi, 143.
18. Palmer, W. W., *J. Biol. Chem.*, 1918, xxxiii, 119.
19. Haldane, J., *J. Physiol.*, 1895, xviii, 463. See also Boycott and Douglas.
20. Krogh, A., *Skand. Arch. Physiol.*, 1910, xxiii, 217.
21. Haldane, J., Douglas, C. G., and Haldane, J. B., *J. Physiol.*, 1912, xlv, 309.

A NOTE ON THE DETERMINATION OF CATALASE IN BLOOD.*

By MEYER BODANSKY.

(From the Chemical Laboratory, U. S. Army General Hospital No. 9, Lakewood, N. J.)

(Received for publication, September 3, 1919.)

During the course of several hundred determinations of catalase in the blood of normal and pathological individuals according to the method employed by Burge,¹ the author observed a consistent variation of from 15 to 35 per cent in the volume of oxygen evolved, depending upon the hydrogen peroxide solution used. The hydrogen peroxide used in these determinations was prepared by diluting commercial 3 per cent hydrogen peroxide solution with an equal volume of distilled water.

Method.

0.2 cc. of the blood was placed in a small crucible which was introduced into a bottle containing 100 cc. of approximately 1.5 per cent (4.6 volume per cent) hydrogen peroxide and a drop of caprylic alcohol. The bottle, which was kept at 22°C. in a water bath, was shaken 120 double shakes per minute for 10 minutes and the oxygen evolved was conducted through rubber tubes into inverted burettes and measured. The volume of oxygen obtained varied between 275 and 425 cc. with different bloods.

In a later paper Burge² states that he found it necessary to use the same make of hydrogen peroxide in all the determinations as the different makes gave different results. For his work he

* Published with permission of the Chief of the Laboratory, Lt. T. E. Buckman.

¹ Burge, W. E., *Am. J. Physiol.*, 1916, xli, 153.

² Burge, W. E., Kennedy, J., and Neill, A. J., *Am. J. Physiol.*, 1917, xliii, 435.

purchased 200 liters of hydrogen peroxide which was kept in a container in a dark, cool place.

It has been found, in this laboratory, that different samples of the same make of hydrogen peroxide often gave results which differed by 15 to 35 per cent. Since all the samples contained the same preservative (acetanilide) in approximately the same amount (0.05 per cent), it was assumed that the discrepancies were due to the difference in the acidity of the various samples.

A series of experiments was performed to test this assumption. A set of H_2O_2 solutions, 5.8 volumes per cent, containing varying amounts of HCl or NaOH was prepared. As alkaline solutions of hydrogen peroxide decompose on standing, the solutions for these experiments were freshly prepared.

2 cc. of blood containing a slight trace of potassium oxalate were diluted to 200 cc. with distilled water. 5 cc. of this solution, equivalent to 0.05 cc. of the blood, were placed in a small crucible and introduced into a bottle containing 20 cc. of hydrogen peroxide solution and one drop of caprylic alcohol. The bottle, kept at 22°C . in a water bath, was shaken 120 double shakes per minute for 10 minutes. The oxygen evolved was conducted through rubber tubes into inverted burettes and the volumes measured at intervals of $\frac{1}{2}$ minute. All gas volumes were calculated to standard conditions; *i.e.*, 0°C . and 760 mm. Hg. pressure.

The results are given in Charts 1 and 2.

A reference to the charts will show the effect of acid and alkali on the velocity of the reaction. The activity of the enzyme catalase was completely inhibited when the hydrogen ion concentration was pH 1, and was slight in a concentration of pH 2. The velocity of the reaction increases as the acidity of the hydrogen peroxide is decreased and is greatest when the solution is slightly alkaline. The activity of the enzyme was considerably retarded when the concentration of the NaOH was above pH 11.

Falk, McGuire, and Blount³ point out that there is no well defined hydrogen ion concentration for maximum action with oxidase, peroxidase, and catalase. According to Sørensen,⁴ the

³ Falk, K. G., McGuire, G., and Blount, E., *J. Biol. Chem.*, 1919, xxxviii, 237.

⁴ Sørensen, S. P. L., *Biochem. Z.*, 1909, xxi, 288.

optimum hydrogen ion concentration for catalase depends on the duration of the reaction. Thus he finds pH 6.73 the optimum for 320 minutes, and pH 7.1 for 40 minutes. With blood catalase under the experimental conditions stated above, I find the optimum to be about pH 7.5 for 10 minutes, about pH 8 for 5 minutes, and about pH 10 for 2 minutes.

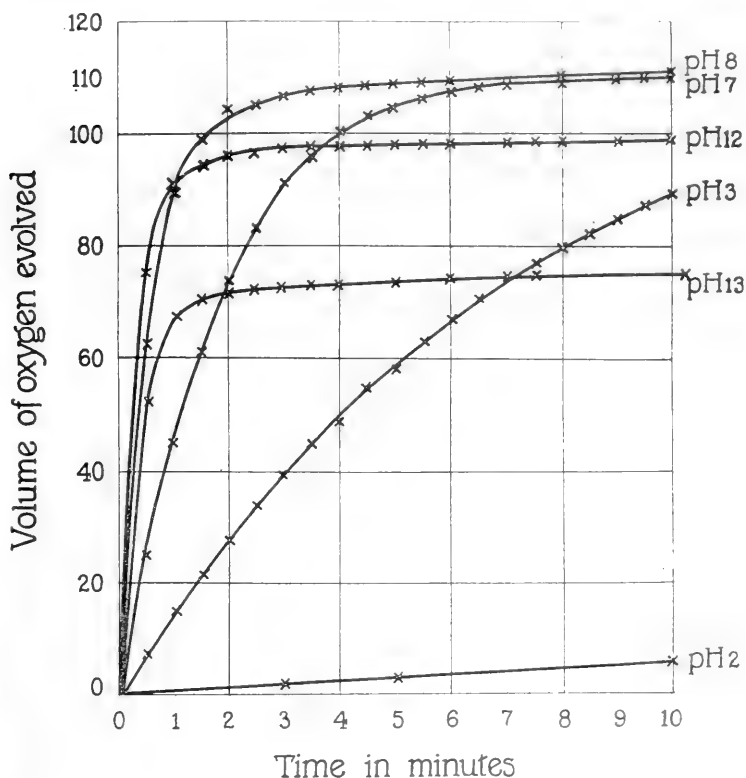

CHART 1. Curves showing the effect of the hydrogen ion concentration of the hydrogen peroxide on the velocity of the reaction between catalase and hydrogen peroxide.

As far as I am aware there is no satisfactory absolute method for the determination of catalase. Nearly all the methods in use give relative results. Slight changes in temperature, impurities in, and the reaction of the hydrogen peroxide influence the

reaction very materially. These experiments emphasize the caution which must be exercised in maintaining uniform conditions especially when a series of determinations is made over a long period of time.

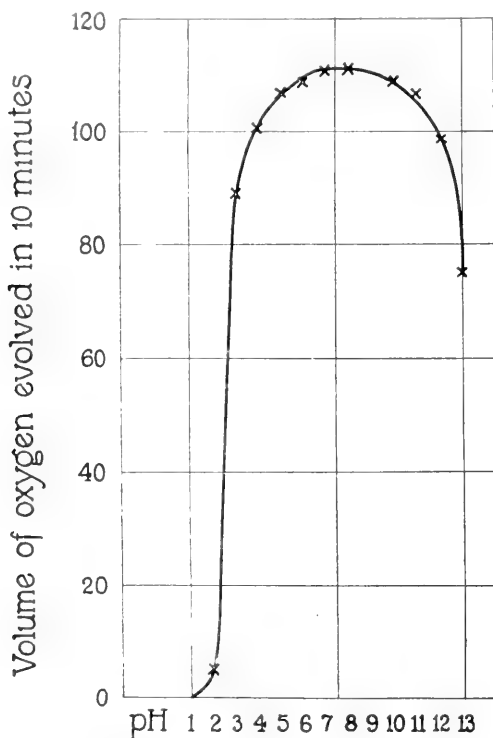

CHART 2. Curve showing the effect of the hydrogen ion concentration of the hydrogen peroxide on the volume of oxygen evolved in 10 minutes.

The author's thanks are due to Lieutenant T. E. Buckman and Lieutenant G. L. Foster of this laboratory for their helpful suggestions.

THE ACTION OF FURFUROL AND DEXTROSE ON AMINO-ACIDS AND PROTEIN HYDROLSATES.

BY C. T. DOWELL AND PAUL MENAUL.

(From the Agricultural Experiment Station, Oklahoma Agricultural and Mechanical College, Stillwater.)

(Received for publication, September 22, 1919.)

While hydrolyzing the whole plant, including the seed, of some grain sorghums, we noticed that a large amount of furfural was given off, and since we obtained an unusually large per cent of the nitrogen in the humin it occurred to us that this might be due to a reaction between the amino-acids and furfural. A survey of the literature seems to confirm this idea. For example Grindley and Slater¹ found 15.79 per cent of the nitrogen in the humin formed in the hydrolysis of alfalfa hay, which was a much larger amount than that found in any other substance. Nollau² obtained 13.75 per cent of humin nitrogen from wheat bran. Hart and Sure³ found 11.83 per cent of humin nitrogen when xylan was added in the hydrolysis of casein. Gortner⁴ studied the action of formaldehyde, benzaldehyde, and furfural on certain amino-acids and states that the humin nitrogen is probably due in great part to the formation of furfural in the hydrolysis of the protein.

We found, in attempting to apply the Van Slyke method to analysis of the hydrolsate from the grain sorghum plant, not only a large amount of humin nitrogen but also incomplete precipitation of basic acids which was unexpected as 15 gm. of phosphotungstic acid had been added. The addition of 50 gm. of the acid was required for complete precipitations. This amount precipitated from 30 to 33 per cent of the total nitrogen. Only

¹ Grindley, H. S., and Slater, M. E., *J. Am. Chem. Soc.*, 1915, xxxvii, 2762.

² Nollau, E. H., *J. Biol. Chem.*, 1915, xxi, 611.

³ Hart, E. B., and Sure, B., *J. Biol. Chem.*, 1916-17, xxviii, 241.

⁴ Gortner, R. A., *J. Biol. Chem.*, 1916, xxvi, 177.

a small amount of the precipitate redissolved on warming, nor was it possible to decompose it except to a slight extent with ether-amyl-alcohol mixture. Grindley, Nollau, and others who have applied this method to feedstuffs do not mention having had such difficulties. However, Brewster and Alsberg⁵ in an article which appeared after we had decided to discontinue our efforts to apply the method state that they obtained a much larger per cent of nitrogen in the phosphotungstic precipitate than should be obtained, and attributed this partly to the precipitation of the humin nitrogen by the phosphotungstic acid. They had the same difficulty as we in dissolving the precipitate. It seemed to us that this trouble was caused by the humin which remained in solution even after it was made alkaline, but was precipitated by the phosphotungstic acid.

These difficulties led us to study the action of furfurol and dextrose on amino-acids and protein hydrolsates. One would expect that some of the amino-acids would react more readily with aldehydes and sugars than would others, and if this is true it would make the application of the Van Slyke method to feedstuffs useless. The results obtained by McHargue⁶ in hydrolyzing casein in the presence of starch for different lengths of time might be due to the difference in reactivity of the amino-acids with sugars or aldehydes. We have succeeded in obtaining but a few of the amino-acids. However, it is thought worth while to report the results already obtained and also our study of the action of furfurol and dextrose on amino-acids and protein hydrolsates.

EXPERIMENTAL.

Action of Furfurol on Amino-Acids.

Determination of the amino nitrogen was made by the Van Slyke method on the stock solution of the amino-acids and on the solution boiled with HCl and furfurol in acid solution. The results are shown in Table I. Two trials were made with glycine without getting evidence of a reaction between it and furfurol.

It was found that furfurol, when boiled with HCl, changes into a black humin-like mass and it was thought that the decrease in

⁵ Brewster, J. F., and Alsberg, C. L., *J. Biol. Chem.*, 1919, xxxvii, 367.

⁶ McHargue, J. S., *J. Agric. Research*, 1918, xii, 1.

TABLE I.
Action of Furfural on Amino-Acids in 10 Per Cent HCl.

Acid.	Time boiled.	Amount of furfural.	Volume of amino N ₂ in 10 cc. of solution.	N ₂ recovered.
	<i>hrs.</i>	<i>cc.</i>		<i>per cent</i>
Tyrosine	2	0	5.9	89.8
"	2	1	5.3	
"	2	0	27.0	
"	2	2	24.5	90.7
Cystine.....	2	0	32.5	
"	2	1	27.5	84.6
Glycine.....	2	0	33.7	100.0
"	2	1.5	33.5	

amino nitrogen might be due to adsorption by this substance. To determine whether or not this was true 50 gm. of grain sorghum plant, ground to pass through a 20 mesh, were hydrolyzed in an autoclave at 20 pounds pressure in 10 per cent HCl for 3 hours (we had shown this to give complete hydrolysis) and the humin was washed with 2,500 cc. of hot water by decantation. It was then washed in the same way with another 2,500 cc. and this last was evaporated to 25 cc. and the amino nitrogen determined; 2.14 mg. were obtained. The 18 gm. of humin contained 165.4 mg. of amino nitrogen. This with a similar result showed that our results with the amino-acids given in Table I were not due to adsorption.

Action of Furfural on Protein Hydrolsates.

Samples of shrimp, casein, wool, and salmon were hydrolyzed in an autoclave as already described and, after filtering off the humin, portions of the solutions, which had been made neutral, were boiled in HCl solution with the addition of furfural. The results are shown in Table II. The substances were selected so as to have hydrolsates containing largely basic acids in some solutions and mono-acids in others.

TABLE II.
Action of Furfurol on Prot in Hydrolysates in Acid.

Hydrolysate.	Volume of amino N ₂ in 10 cc. of solution before treatment with furfurol.	Amount of furfurol.	Concentration of acid.	Time of boiling.	Volume of amino N ₂ in 10 cc. of solution after treatment with furfurol.	Amino N ₂ recovered.
	cc.	cc.	per cent	hrs.	cc.	per cent
Shrimp.....	29.4	1	10	2	29.0	98.6
Casein.....	12.0	1	10	2	11.5	95.8
Wool.....	27.3	1	10	2	26.3	96.4
Salmon.....	39.0	1	10	2	36.3	93.0
Shrimp.....	16.4	2	5	16	13.1	79.8
Wool.....	17.4	2	5	16	13.5	77.5
Salmon.....	23.35	2	5	16	17.5	74.9

TABLE III.
Effect of Concentration of Acid on Reaction between Furfurol and Casein Hydrolysate.

Concentration of HCl.	Time of boiling.	Amount of furfurol.	Volume of amino N ₂ in 10 cc. of solution before boiling.	Volume of amino N ₂ after boiling.	Amino N ₂ recovered.
per cent	hrs.	cc.			per cent
0	15	2	33.4	17.6	51.1
0	15	2	31.1	21.3	68.4
5	15	2	30.2	26.3	87.0
10	15	2	30.2	27.3	90.3
20	15	2	16.3	15.7	96.3

TABLE IV.
Effect of Concentration of Acid on Reaction between Dextrose and Casein Hydrolysates.

Concentration of HCl.	Time of boiling.	Concentration of Dextrose.	Volume of amino N ₂ in 10 cc. of solution before boiling.	Volume of amino N ₂ after boiling.	Amino N ₂ recovered.
per cent	hrs.	per cent			per cent
20	15	4	33.4	33.4	100.0
20	15	4	31.1	31.1	100.0
20	15	4	16.3	16.0	98.1
10	15	4	30.2	28.9	95.3
5	15	4	30.2	28.8	95.3
Neutral.	15	4	33.4	28.1	84.1
"	15	4	31.1	26.0	83.6

TABLE V.

Effect of Boiling Casein Hydrolsate in 20 Per Cent HCl for 15 Hours in the Presence of Arabinose, Starch, Gum Arabic, and Cellulose.

Name of substance.	Amount of substance.	Volume of amino N ₂ in 10 cc. of solution before boiling.	Volume of amino N ₂ after boiling.	Amino N ₂ recovered.
	<i>gm.</i>			<i>per cent</i>
Arabinose.....	1	16.3	15.4	94.4
Gum Arabic.....	2	16.3	15.9	97.5
Starch.....	2	16.3	15.8	96.9
Cellulose.....	2	16.3	15.8	96.9

SUMMARY.

1. Glycine does not react with furfural. There is no explanation of this since tyrosine and cystine give decided evidence of reaction.

2. It is shown that but a slight amount of the humin nitrogen is due to adsorption.

3. The hydrolsates of shrimp, casein, wool, and salmon react with furfural.

4. The greatest decrease in amino N₂ is obtained when the reaction between a protein hydrolsate and furfural takes place in a neutral or slightly acid solution. This is probably due to the fact that furfural forms a humin-like mass when boiled in acid solution.

5. The greatest effect is obtained in the reaction between dextrose and a protein hydrolsate when the solution is either neutral or slightly acid. This shows that dextrose reacts directly with the amino-acids and not through the intermediate formation of furfural as we thought might be true.

Our results with dextrose together with the fact that we seemed to get a precipitation of humin nitrogen with phosphotungstic acid leads us to think that the method proposed recently by Eckstein and Grindley⁷ for the analysis of feedstuffs by the Van Slyke method would lead to low results. In order to remove the carbohydrates, they digest the sample for 60 hours in 0.1 per cent

⁷ Eckstein, H. C., and Grindley, H. S., *J. Biol. Chem.*, 1919, xxxvii, 373.

hydrochloric acid. This converts starches to sugars, and since the acid concentration is low, the conditions are most favorable for the reaction of the sugars with the amino-acids. It is true that this concentration of acid would not hydrolyze much of the protein, but it should be remembered that there is a high per cent (30 to 40 per cent) of soluble nitrogen, mostly in the form of amino-acids, in many feedstuffs.

6. The results given in Table V show, as would be expected, that substances which yield either sugars or furfurol when boiled with hydrochloric acid decrease the amino nitrogen when boiled with a protein hydrosate.

7. It was found that complete hydrolysis of various proteins is brought about by heating in 10 per cent HCl in an autoclave for 3 hours at a pressure of 20 pounds.

THE HEAT COAGULATION OF MILK.*

BY H. H. SOMMER AND E. B. HART.

(From the Department of Agricultural Chemistry, University of Wisconsin, Madison.)

(Received for publication, September 17, 1919.)

The coagulation of milk by heat was first observed by Hammersten,¹ who found that it occurred at from 130–150°C. with different samples of milk. Since then the question has been studied very little, and no tenable explanation has ever been given for the difference in the coagulating points of milks from different cows. In recent years a knowledge of the factors which determine this difference has become very desirable, for these same factors undoubtedly determine whether a condensed milk will coagulate when it is sterilized. The coagulation of condensed milk on sterilizing causes serious losses in the milk-condensing industry.

In the manufacture of condensed milk, the fresh milk is first pasteurized or "preheated" at from 180–210°F. for from 1 to 20 minutes. The condensing is done under vacuum at 130–160°F. After the desired concentration has been attained, the milk is put into cans, sealed, and then sterilized at 224–240°F. for 20 to 50 minutes. It is during the sterilizing process that the coagulation occurs. Because it occurs so frequently, all the condensed milk is placed into shaking machines to break up any loose coagulum that may have formed. However, frequently the coagulum is so firm that even after shaking the milk remains lumpy. Such a product is rejected by the consuming public, and thus is a loss.

Manufacturers have sought to solve the problem by controlling the acidity of the milk. They have set an arbitrary standard such as 0.18 per cent acid (calculated as lactic acid), above which

* Published with the permission of the Director of the Wisconsin Agricultural Experiment Station.

¹ Quoted from literature referred to in Kastle, J. H., *Chemistry of milk*; *Hyg. Lab., Bull.* 56, 1909.

they reject all milk. This has led to much difficulty, because often, immediately after it is drawn from the cow, milk has a higher titratable acidity than 0.18 per cent. Thus the condenseries may be rejecting perfectly fresh milk, believing that they are remedying their difficulty in this way, although it has never been demonstrated that titratable acidity is related to the coagulation. The factors involved in the coagulation have never been determined, and no explanation is available on which to base a remedy for this difficulty.

To offer an explanation for the difference in the coagulating points of different milk samples the following factors were studied: titratable acidity, hydrogen ion concentration, concentration of the milk, and composition and balance of the milk salts.

The Heat Test.

The temperature at which the milk was heated was arbitrarily set at 136°C. At first the heating was done in an autoclave at 50 pounds pressure for 20 minutes, and in that way the milks were differentiated into coagulating and non-coagulating. With the autoclave, it took about 10 minutes to get up to the desired pressure; and, after the milk had been heated, the pressure had to be released gradually to prevent the milk from boiling over. The disadvantages of this method were such that there were no sharp limits from which to calculate the 20 minute interval, and it was impossible to determine the relative rates at which the milk samples coagulated.

To overcome these disadvantages the milk was placed into small glass tubes, sealed, and then heated in a xylene vapor bath which was constant at 136°C. within 0.5°C. The sealed tubes were clamped in a rack, so arranged that it could be tilted to invert the tubes, to see how the milk would flow, and in that way it was possible to determine the exact length of time required for each sample to coagulate. The milk in the sealed tubes was up to 136°C. in less than 1 minute, so the point from which to calculate the time was practically the instant the tubes were inserted into the vapor bath.

Titratable Acidity.

Since condenseries are attempting to remedy the coagulation problem by rejecting milk above 0.18 per cent acid (calculated as

TABLE I.
Titratable Acidity and Coagulation.

May 8, 1919.			May 10, 1919.			May 16, 1919.		
Cow No.	Titratable acidity.	Coagulation.	Cow No.	Titratable acidity.	Coagulation.	Cow No.	Titratable acidity.	Coagulation.
	Lactic acid.			Lactic acid.			Lactic acid.	
	<i>per cent</i>	<i>min.</i>		<i>per cent</i>	<i>min.</i>		<i>per cent</i>	<i>min.</i>
1	0.257	20—*	1	0.241	6	31	0.203	4½
2	0.235	3	2	0.231	11	2	0.193	20—
3	0.216	20—	26	0.228	5	1	0.192	20—
4	0.214	20—	31	0.222	5½	3	0.188	4½
5	0.210	8	27	0.212	6	27	0.188	6½
6	0.207	20—	3	0.212	5½	6	0.188	20—
7	0.206	6	4	0.211	20—	4	0.188	20—
28	0.201	20—	5	0.205	5½	28	0.186	20—
9	0.200	20—	9	0.197	20—	12	0.184	10
10	0.200	20—	28	0.199	20—	26	0.184	3
11	0.195	4½	6	0.195	20—	5	0.183	6½
12	0.191	20—	29	0.192	5½	9	0.182	20—
13	0.190	20—	10	0.190	20—	14	0.182	9
14	0.189	6½	13	0.186	9	29	0.182	1¾
15	0.182	20—	12	0.185	11	11	0.178	3½
16	0.179	4	11	0.184	5	13	0.175	4
8	0.174	9	8	0.174	20—	10	0.171	20—
17	0.172	20—	14	0.175	6½	30	0.165	20—
18	0.167	20—	15	0.172	20—	15	0.163	20—
19	0.158	12	17	0.166	20—	8	0.163	6½
20	0.157	20—	18	0.160	20—	17	0.156	20—
21	0.156	20—	30	0.162	4	18	0.154	20—
22	0.148	3	7	0.162	2	7	0.148	2
23	0.146	3½	21	0.157	20—	20	0.143	20—
24	0.143	20—	20	0.147	20—	19	0.135	20—
25	0.120	2	23	0.145	5½	22	0.133	2
			19	0.144	20—	23	0.130	4
			22	0.144	2	24	0.128	20—
			24	0.141	20	21	0.128	20—
			25	0.131	1½	25	0.102	1½

*20— = no coagulation in 20 minutes.

lactic acid), it was of interest to know how much variation there was in the titratable acidity of milk from individual cows, and what relation the acidity would bear to the coagulation. To study this, samples were taken from the University herd and titrated immediately, and the heat test in the xylene vapor bath applied as soon as possible. The results given in Table I were obtained.

The titratable acidity varies from 0.102 to 0.257 per cent. Out of the 86 samples, 45 are above 0.18 per cent.

In fresh milk there is no direct relation between titratable acidity and coagulation, as is evident from Table II. If fresh milk samples were more nearly alike in titratable acidity, then titratable acidity might bear a direct relationship to the heat

TABLE II.
Summary of Titratable Acidity and Coagulation.

Date.	No. of samples.	No. above 0.18 per cent acid.*	No. that are 20+ †	No. below 0.18 per cent acid. ‡	No. that are 20+.
May 8.....	26	15	5	11	6
" 10.....	30	14	7	16	7
" 16.....	30	16	11	14	6
Total.....	86	45	23	41	19

* Per cent above 0.18 per cent acidity, coagulating 20+ = 51.2 per cent.

† 20+ means coagulation within 20 minutes.

‡ Per cent below 0.18 per cent acidity, coagulating 20+ = 46.4 per cent.

coagulation of commercial milk samples. The acidity would then be a measure of the amount of fermentation that had taken place. Lactic acid fermentation lowers the coagulating point in two ways; (1) it changes the reaction, and (2) it lowers the citric acid content of the milk very rapidly.² Both of these are factors in lowering the coagulating point, as will be shown later.

Since fresh milk samples vary so widely in titratable acidity, it is impossible to measure the extent of acid fermentation in a sample by titration. For this reason it is impossible to use titratable acidity as a criterion of coagulability.

² Bosworth, A. W., and Prucha, M. J., *Tech. Bull. 14, N. Y. Agric. Exp. Station, 1910.*

TABLE III.
Hydrogen Ion Concentration and Coagulation.

Date.	Cow.	pH	C _H	Coagulation in 20 min.
<i>1919</i>				
Feb. 21	31	6.55	2.82×10^{-7}	+++*
	32	6.83	1.48×10^{-7}	+
	13	6.58	2.63×10^{-7}	+++
	24	6.83	1.48×10^{-7}	-
" 25	13	6.25	5.62×10^{-7}	-
	32	6.66	2.19×10^{-7}	-
	31	6.66	2.19×10^{-7}	+++
" 26	13	6.58	2.63×10^{-7}	+++
	32	6.69	2.04×10^{-7}	++
	31	6.70	1.99×10^{-7}	++
	24	6.73	1.86×10^{-7}	+
	14	6.70	1.99×10^{-7}	+++
" 27	13	6.44	3.62×10^{-7}	+
	32	6.64	2.29×10^{-7}	++
	31	6.64	2.29×10^{-7}	+++
" 27	24	6.70	1.99×10^{-7}	-
	14	6.44	3.62×10^{-7}	-
	33	6.59	2.56×10^{-7}	+++
" 28	13	6.50	3.16×10^{-7}	-
	31	6.94	1.15×10^{-7}	+++
	32	6.92	1.20×10^{-7}	-
	24	6.93	1.17×10^{-7}	++
	14	6.50	3.16×10^{-7}	-
	33	6.68	2.09×10^{-7}	+++
Mar. 3	13	6.67	2.14×10^{-7}	-
	31	6.84	1.44×10^{-7}	-
	33	6.69	2.04×10^{-7}	++
" 5	33	6.64	2.29×10^{-7}	+++
	13	6.64	2.29×10^{-7}	-
	31	6.93	1.17×10^{-7}	+
	32	6.79	1.62×10^{-7}	-
	24	6.79	1.62×10^{-7}	-
	14	6.58	2.63×10^{-7}	-
" 6	24	6.97	1.07×10^{-7}	+
	33	6.59	2.57×10^{-7}	+++
" 7	31	6.85	1.41×10^{-7}	+++
" 10	33	6.79	1.62×10^{-7}	+++

* Number of plus signs indicates degree of firmness.

Hydrogen Ion Concentration.

Titrate acidity does not give an index to true acidity, or hydrogen ion concentration, so that if there is any relation between acidity and coagulation, it would be most likely to exist between the hydrogen ion concentration and coagulation. To study this possibility the hydrogen ion concentration of fresh milk was determined by means of the gas chain method, and the heat test was applied by means of the autoclave. The results given in Table III were obtained.

From a study of the data it becomes evident that the hydrogen ion concentration is not the determining factor in the coagulation. Samples of equal C_H do not always respond alike to the heat test; one may remain liquid, and the other may form a firm coagulum. In a large number of cases samples of high C_H did not coagulate, whereas samples of lower C_H did, the exact reverse of what should happen if true acidity was the cause of the coagulation.

We must conclude from this that in fresh milk C_H is not the determining factor in the coagulation. However, it may become a factor, for if we change the reaction of a milk sample by adding small amounts of acids the coagulating point is lowered.

Concentration.

The concentration of the milk would be expected to influence the coagulating point. This was found to be the case when milk was diluted (Table IV).

TABLE IV.

Relation of Coagulation to Concentration.

25 cc. of milk + H ₂ O.		Coagulation time.
H ₂ O added.		
cc.		min.
0.0		1½
1.0		2
2.0		2¾
3.0		14
4.0		35-
5.0		35-
6.0		35-

Not only the concentration of the casein influences the coagulating point, but also the concentration of the serum. This was determined by comparing the effect of water dilution to the effect of dilution with milk serum obtained by filtering the milk through Pasteur-Chamberlain filters (Table V).

In the dilution with water, where the casein and the serum are both diluted, the effect is greater than where the casein alone is diluted by adding serum; therefore, the concentration of the serum is also a factor influencing the coagulating point.

Concentration of casein and of serum may in part explain the difference in the coagulating points of different milk samples.

TABLE V.
Relation of Coagulation to Concentration of Serum.

25 cc. of milk + serum.	
Serum added.	Coagulation time.
cc.	min.
0.0	1 $\frac{1}{2}$
0.1	1 $\frac{3}{4}$
0.2	2

25 cc. of milk + H ₂ O.	
H ₂ O added.	Coagulation time.
cc.	min.
0.0	1 $\frac{1}{2}$
0.1	2 $\frac{1}{2}$
0.2	4

However, in most cases, with the slight variation in concentration, this factor is of minor importance, just as C_H is. There must be another factor of greater importance.

Composition and Balance of Milk Salts.

Since electrolytes have a very marked effect upon the stability of colloids, we should expect that variations in the salt composition would influence the stability of the casein in the milk.

That the various salts exert an influence on the coagulating point was shown in a number of cases.

The effect of an addition of ammonium oxalate to milk that previously coagulated is shown in Table VI.

The removal of calcium by precipitation prevents coagulation in most cases and similarly in most cases the addition of small amounts of calcium salts lowers the coagulating point. This coagulation can again be balanced by means of sodium citrate or dipotassium phosphate (Tables VII, VIII, IX, and X). Coagulation caused by $MgCl_2$ or $BaCl_2$ can also be balanced by sodium citrate (Tables XI and XII).

In most cases coagulation can be prevented by the addition of citrates or phosphates, the coagulation being due to an excess of calcium and magnesium. However, in a few cases the addition of citrates or phosphates did not prevent coagulation, but rather

TABLE VI.
Ammonium Oxalate Prevents Coagulation.

5 cc. of milk + 10 per cent $(NH_4)_2 C_2O_4$.	Coagulation in 20 min.
$(NH_4)_2 C_2O_4$ added.	
<i>drops</i>	
0	+++
1	++
2	+
3	—
4	—

hastened it. In these cases the addition of the proper amount of calcium salts prevents coagulation or at least raises the coagulating point (Tables XIII and XIV).

From the data we see that the calcium and magnesium are balanced by the phosphates and citrates of the milk practically in gram-equivalent amounts. The sodium and potassium chlorides in the concentrations present do not have any marked influence on the coagulating point, so that the balance of the four constituents, calcium, magnesium, citrates, and phosphates, largely determines whether a milk will coagulate or not. If calcium and magnesium are in excess, the milk will coagulate on heating. If calcium and magnesium are properly balanced with the phosphates and citrates, the optimum stability obtains. If phosphates and citrates are in excess, coagulation will also result.

TABLE VII.
*Balance between Calcium and Citrates.**

25 cc. of milk plus.			Coagulation time.
m/2 Ca acetate.	m/2 Na citrate.	H ₂ O	
cc.	cc.	cc.	min.
0.0	0.0	1.3	3
0.3	0.0	1.0	$\frac{1}{2}$
0.3	0.1	0.9	2 $\frac{1}{2}$
0.3	0.2	0.8	3
0.3	0.3	0.7	2
0.3	0.4	0.6	1 $\frac{1}{2}$

*The sodium citrate consisted of 25 cc. of sodium m/2 citrate plus 3 cc. of m/2 citric acid. This solution was distinctly acid, so that the balancing effect could not have been due to neutralization of acidity by means of the sodium citrate.

TABLE VIII.
*Balance between Calcium and Citrates.**

25 cc. of milk plus.			Coagulation time.
m/2 Ca acetate.	m/2 Na citrate.	H ₂ O	
cc.	cc.	cc.	min.
0.0	0.0	1.6	4
0.4	0.0	1.2	$\frac{1}{2}$
0.4	0.2	1.0	40—
0.4	0.4	0.8	40—
0.4	0.6	0.6	2 $\frac{1}{4}$
0.4	0.8	0.4	2

*The sodium citrate consisted of 25 cc. of m/2 sodium citrate plus 1 cc. of m/2 citric acid.

TABLE IX.
Balance between Calcium and Citrates.

25 cc. of milk plus.			Coagulation time.
m/2 Ca acetate.	m/2 Na citrate.	H ₂ O	
cc.	cc.	cc.	min.
0.0	0.0	1.8	25—
0.8	0.0	1.0	$\frac{1}{8}$
0.8	0.4	0.6	$\frac{1}{8}$
0.8	0.6	0.4	25—
0.8	0.8	0.2	25—
0.8	1.0	0.0	4 $\frac{1}{2}$

TABLE X.
Balance between Calcium and Phosphates.

25 cc. of milk plus.			Coagulation time.
M/2 Ca acetate.	M/2 K ₂ HPO ₄	H ₂ O	
cc.	cc.	cc.	min.
0.0	0.0	1.2	20—
0.5	0.0	0.7	$\frac{1}{4}$
0.5	0.2	0.5	$\frac{3}{8}$
0.5	0.3	0.4	1
0.5	0.4	0.3	20—
0.5	0.5	0.2	20—
0.5	0.6	0.1	20—
0.5	0.7	0.0	6

TABLE XI.
Balance between Magnesium and Citrates.

25 cc. of milk plus.			Coagulation time.
M/2 MgCl ₂	M/2 Na citrate.	H ₂ O	
cc.	cc.	cc.	min.
0.0	0.0	0.7	20—
0.3	0.0	0.4	$\frac{1}{2}$
0.3	0.2	0.2	20—
0.3	0.3	0.1	20—
0.3	0.4	0.0	8

TABLE XII.
Balance between Barium and Citrates.

25 cc. of milk plus.			Coagulation time.
M/2 BaCl ₂	M/2 Na citrate.	H ₂ O	
cc.	cc.	cc.	min.
0.0	0.0	0.4	20—
0.2	0.0	0.2	$\frac{1}{8}$
0.2	0.2	0.0	20—

Thus the coagulation of a milk sample on heating may be due either to an excess or a deficiency of calcium and magnesium. We may explain this in the following manner. The casein of the milk is most stable with regard to heat coagulation when it is in combination with a definite amount of calcium. If the calcium

combined with the casein is above or below this optimum, the casein is not in its most stable condition. The calcium in the milk distributes itself between the casein, citrates, and phosphates chiefly. If the milk is high in citrate and phosphate content, more calcium is necessary in order that the casein may retain its optimum calcium content after competing with the citrates and phosphates. If the milk is high in calcium, there may not be

TABLE XIII.

A Sample in Which Calcium Prevents Coagulation.

25 cc. of milk plus.			Coagulation time.
m/2 Ca acetate.	m/2 Na citrate.	H ₂ O	
cc.	cc.	cc.	min.
0.0	0.0	0.8	1 $\frac{1}{2}$
0.2	0.0	0.6	20—
0.2	0.1	0.5	1 $\frac{1}{4}$
0.2	0.2	0.4	1
0.2	0.3	0.3	$\frac{3}{4}$
0.2	0.4	0.2	$\frac{3}{4}$

TABLE XIV.

A Sample in Which Calcium Raises the Coagulating Point.

25 cc. of milk plus.		Coagulation time.
m/4 Ca acetate.	H ₂ O	
cc.	cc.	min.
0.0	0.5	1 $\frac{3}{4}$
0.1	0.4	2
0.2	0.3	2 $\frac{1}{4}$
0.3	0.2	3
0.4	0.1	6
0.5	0.0	2 $\frac{1}{2}$

sufficient citrate and phosphate to compete with the casein to lower its calcium content to the optimum. In such a case the addition of citrates or phosphates makes the casein more stable by reducing its calcium content. The magnesium functions by replacing the calcium in the citrates and phosphates.

In most cases the coagulation is due to an excess of calcium and magnesium. It is possible to balance this excess by citrates,

TABLE XV.
Analyses to Show Balance between Salts as Related to Coagulation.

1	2	3	4	5	6	7	8	9	10	11	12	13	14	15
Sample No.	Citric acid.	P ₂ O ₅	CaO	MgO	Citric acid Gram-equivalent.	P ₂ O ₅ Gram-equivalent.	CaO Gram-equivalent.	MgO Gram-equivalent.	Citric acid + P ₂ O ₅ Gram-equivalent.	CaO + MgO Gram-equivalent.	Column 11 minus Column 10.	Column 12 minus 0.40.	Coagulation time.	Total solids.
	per cent	per cent	per cent	per cent									min.	per cent
1	0.100	0.216	0.189	0.023	0.52	1.91	3.38	0.56	2.46	3.94	+1.48	+1.08	1½	12.41
2	0.292	0.255	0.191	0.021	1.52	2.30	3.41	0.51	3.82	3.98	+0.16	-0.24	1½	15.02
3	0.191	0.236	0.184	0.025	0.99	2.13	3.29	0.62	3.12	3.91	+0.79	+0.39	2	13.55
4	0.130	0.193	0.148	0.022	0.68	1.74	2.64	0.55	2.42	3.19	+0.77	+0.37	2	9.79
5	0.165	0.292	0.189	0.022	0.86	2.63	3.38	0.55	3.49	3.93	+0.44	+0.04	3	15.20
6	0.145	0.277	0.210	0.021	0.76	2.50	3.75	0.53	3.26	4.28	+1.02	+0.62	3½	15.25
7	0.220	0.237	0.185	0.028	1.15	2.13	3.30	0.70	3.28	4.00	+0.72	+0.32	4	14.40
8	0.240	0.200	0.179	0.024	1.25	1.80	3.19	0.60	3.05	3.79	+0.74	+0.34	4	13.19
9	0.220	0.291	0.181	0.029	1.15	2.65	3.23	0.74	3.80	3.97	+0.17	-0.23	4½	14.30
10	0.207	0.280	0.204	0.025	1.08	2.52	3.64	0.63	3.60	4.27	+0.67	+0.27	4½	14.76
11	0.213	0.287	0.196	0.027	1.11	2.58	3.50	0.67	3.69	4.17	+0.48	+0.08	6½	14.14
12	0.161	0.278	0.190	0.026	0.85	2.49	3.39	0.65	3.34	4.04	+0.70	+0.30	6½	14.98
13	0.163	0.233	0.184	0.026	0.85	2.10	3.28	0.64	2.95	3.92	+0.87	+0.47	6½	14.02
14	0.124	0.258	0.170	0.025	0.65	2.32	3.04	0.62	2.97	3.66	+0.69	+0.29	9	14.14
15	0.312	0.246	0.204	0.023	1.62	2.21	3.64	0.59	3.83	4.24	+0.41	+0.01	10	13.23
16	0.194	0.273	0.158	0.024	1.01	2.46	2.82	0.60	3.47	3.42	-0.05	-0.45	20--	13.34
17	0.185	0.252	0.167	0.021	0.96	2.25	2.98	0.52	3.21	3.50	+0.29	-0.11	20--	13.75
18	0.168	0.262	0.164	0.026	0.88	2.36	2.93	0.65	3.24	3.58	+0.34	-0.06	20--	12.47

19	0.192	0.234	0.160	0.021	1.00	2.11	2.86	0.53	3.11	3.39	+0.28	-0.12	20-	12.61
20	0.210	0.249	0.193	0.025	1.09	2.24	3.45	0.61	3.33	4.06	+0.67	+0.27	20-	12.65
21	0.234	0.240	0.132	0.026	1.22	2.16	2.36	0.64	3.38	3.00	-0.38	-0.78	20-	14.17
22	0.213	0.196	0.145	0.019	1.11	1.76	2.59	0.46	2.87	3.05	+0.18	-0.22	20-	10.81
23	0.237	0.253	0.176	0.021	1.23	2.28	3.14	0.52	3.51	3.66	+0.15	-0.25	20-	13.41
24	0.225	0.240	0.158	0.022	1.17	2.16	2.82	0.55	3.33	3.37	+0.04	-0.36	20-	14.09
25	0.170	0.238	0.148	0.025	0.89	2.14	2.64	0.62	3.03	3.26	+0.33	-0.07	20-	14.39
26	0.243	0.196	0.164	0.023	1.27	1.77	2.93	0.57	3.04	3.50	+0.46	+0.06	20-	11.31
27	0.216	0.219	0.156	0.022	1.13	1.97	2.79	0.55	3.10	3.34	+0.21	-0.16	20-	12.59
28	0.238	0.201	0.162	0.022	1.24	2.62	2.89	0.54	3.86	3.43	-0.43	-0.83	20-	12.67
29	0.161	0.224	0.179	0.020	0.84	2.02	3.19	0.49	2.86	3.68	+0.82	+0.42	20-	13.60
30	0.144	0.206	0.139	0.020	0.75	1.85	2.48	0.51	2.60	2.99	+0.39	-0.01	20-	11.36

phosphates, carbonates, and other salts. It is also stated that danger of coagulation may be avoided in the actual practice of condensing milk by lengthening the "preheating" period, using higher temperatures. This may have the effect of lowering the soluble calcium content by precipitating part of it as insoluble calcium phosphate.¹

To demonstrate the importance of the salt balance in the coagulation of milk, a number of samples were analyzed for total citric acid, phosphorus, calcium, and magnesium (Columns 2, 3, 4, and 5, Table XV). To calculate the balance between citric acid and phosphates, and calcium and magnesium the percentages were converted into gram-equivalents as follows:

$$(a) \frac{\text{Citric acid}}{192} \times 100$$

$$(b) \frac{\text{P}_2\text{O}_5 \times 100}{71} \times \frac{7}{11}^*$$

$$(c) \frac{\text{CaO} \times 100}{56}$$

$$(d) \frac{\text{MgO} \times 100}{40}$$

* Multiply by $\frac{7}{11}$ because at pH 6.50, the average reaction of milk, the ratio of primary to secondary phosphate, is such that the mean basicity of the phosphates is approximately $\frac{7}{11}$ of what it would be if all the phosphates were secondary phosphates.

Column 10 shows the sum of citric and phosphoric acids in gram-equivalents; Column 11, the sum of calcium and magnesium in gram-equivalents. Column 12 shows the balance; a plus sign showing an excess of calcium and magnesium, and a minus sign showing an excess of citric and phosphoric acids. In only a few cases is there an excess of citric and phosphoric acids, and the excess is small. Those that coagulated had the largest excess of calcium and magnesium. To make this result more apparent, Column 13 shows the values of Column 12 minus 0.40. This figure was arbitrarily chosen and subtracted so as to make the coagulating samples have a plus sign and the non-coagulating samples have a minus sign. In five cases out of the thirty this result does not hold. However, the fact that, in twenty-five out of the thirty samples, those having the highest excess of calcium and magnesium

over citrates and phosphates coagulated and those having the lowest excess did not coagulate, indicates that this factor is very important.

The five exceptions may be due to the other factors, concentration and reaction. Samples 2 and 9, with their small excesses of calcium and magnesium, should not coagulate; however, both samples are high in total solids. Samples 20 and 26 did not coagulate although the excess of calcium and magnesium is high; again the explanation may lie partly in the concentration of the milk, both samples being low in total solids. If the pH had been determined we might have gained further insight into these exceptions and an explanation for the irregularity of Sample 29.

SUMMARY AND CONCLUSIONS.

1. The main factor in the heat coagulation of fresh milk is the composition of the milk salts. Apparently casein requires a definite optimum calcium content for its maximum stability. The calcium content of casein is largely controlled by the magnesium, citrates, and phosphates present.

2. In fresh milk there is no relation between titratable acidity and heat coagulation.

3. Acid fermentation in milk lowers the coagulating point by changing the reaction and by lowering the citric acid content. However, the titratable acidity of fresh milk samples varies so widely that it is impossible to determine the extent of acid fermentation by titration. Therefore it is impossible to use the acidity of milk as a criterion of coagulability.

4. Difference in concentration accounts partly for the difference in coagulation of fresh milk samples.

5. Hydrogen ion concentration is not the determining factor in fresh milk coagulation. It is nevertheless a factor in fresh milks, and in commercial milks it may become an important factor.

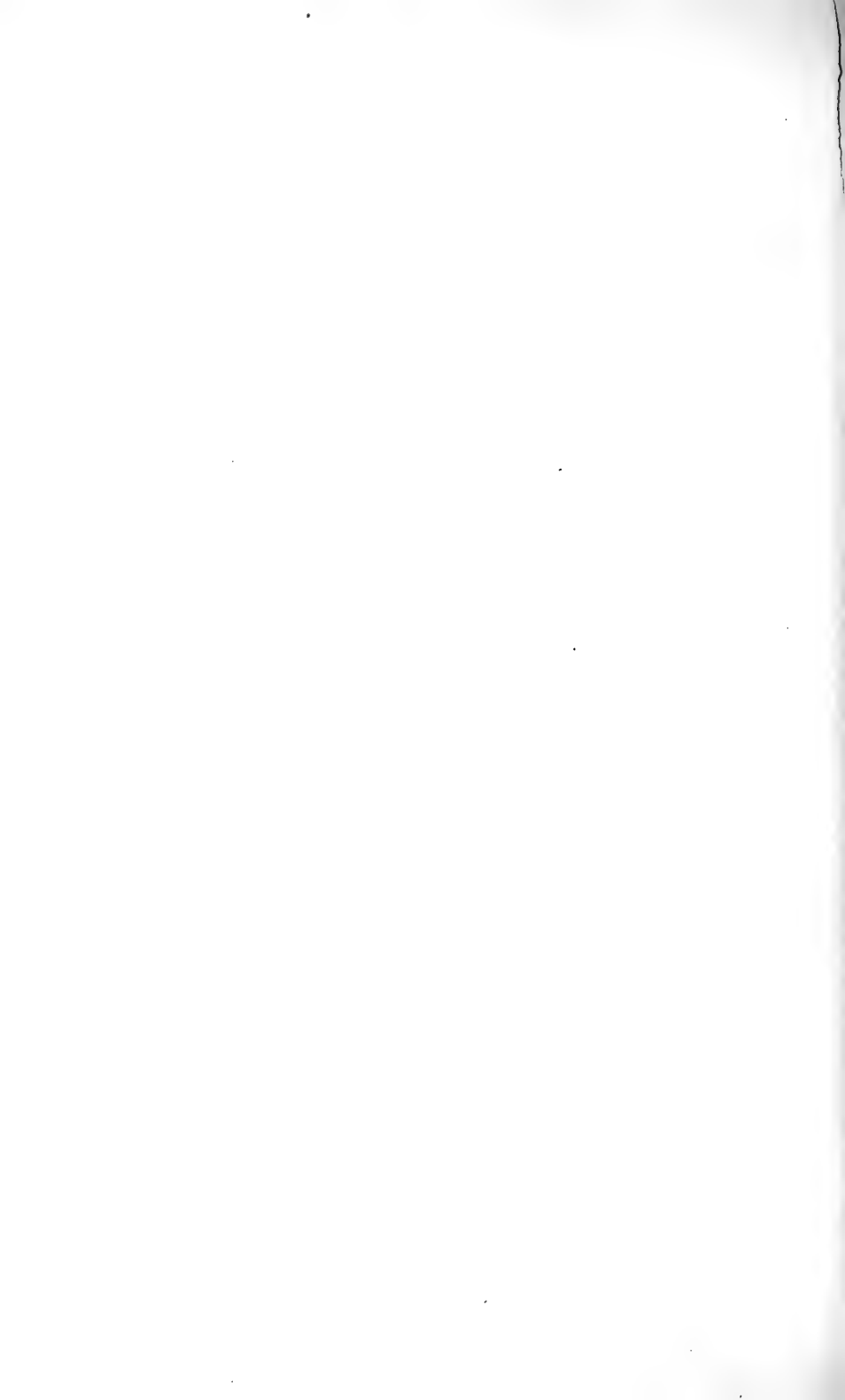

THE ACTION OF INTRAVENOUS INJECTIONS OF PANCREAS EMULSIONS IN EXPERIMENTAL DIABETES.

By ISRAEL S. KLEINER.

(From the Department of Physiology and Pharmacology of The Rockefeller Institute for Medical Research.)

(Received for publication, September 20, 1919.)

It is evident that the demonstration of a beneficial effect of a pancreas preparation, when administered parenterally to a diabetic animal, would be of importance both theoretically and practically. Theoretically it would support the internal secretion hypothesis of the origin of diabetes. Practically it would suggest a possible therapeutic application.

The early work in this field was either negative or, as Pflüger,¹ and Leschke² have shown, is open to serious criticism. The usual criterion was a lowering of the concentration of sugar in the urine or a diminution of the total 24 hour output of sugar. Either of these effects may easily be caused by a diminished intake of food, due to the loss of appetite usually resulting from the treatment, to a change in the character of the diet, or to an influence on the kidneys. In clinical experience, the *feeding* of pancreas preparations has sometimes seemed to have a favorable subjective effect but with no constant antidiabetic action. Often this appeared to be due to supplying the *external* secretion to patients in need of it. Parenteral administration usually has not given good results. In a brief résumé of the literature Allen³ says: "Though pancreas feeding may have at least a digestive value in some cases of diabetes, injections of pancreatic preparations have proved both useless and harmful. The failure began with Minkowski, and has continued to the present without an exception."

The more recent work may be summarized very briefly. Scott⁴ found that intravenous injections of water extracts of pancreatic tissue, which had previously been extracted with alcohol, diminished temporarily the

¹ Pflüger, E., *Arch. ges. Physiol.*, 1907, cxviii, 267.

² Leschke, E., *Arch. Physiol.*, 1910, 401.

³ Allen, F. M., *Studies concerning glycosuria and diabetes*, Cambridge, 1913, 815.

⁴ Scott, E. L., *Am. J. Physiol.*, 1911-12, xxix, 306.

154 Pancreas Emulsions in Experimental Diabetes

sugar excretion of diabetic dogs and lowered their D/N ratio. Murlin and Kramer⁵ injected boiled pancreatic extracts into depancreatized dogs and found a temporary reduction in the output of sugar. A mixed boiled extract of pancreas and duodenal mucosa produced a greater fall, and in one case a complete disappearance of the urinary sugar. The results were referred by these authors mainly to the sodium carbonate present in the extracts, because Ringer's solution, which had been brought to about the same degree of alkalinity as the medium used for the extract, was found to have similar effects. Later the preliminary announcement⁶ of the present work led Murlin and Kramer⁷ to try unboiled pancreatic extract. This was given by mouth, however, and was mixed with Na₂CO₃. A favorable influence on the respiratory quotient was observed in two experiments.

The present work was undertaken because of the remarkable influence which an emulsion of pancreas had been found to exert upon the disposition of intravenously injected dextrose in diabetic dogs. In normal animals⁸ large quantities of sugar, introduced intravenously, were promptly lost from the circulation; in diabetic animals,^{6,9} on the other hand, this occurred very slowly, as was shown by the fact that even an hour and a half after the end of the sugar infusion the blood sugar was still far above its original level. Now, when an emulsion of pancreas was mixed with the glucose solution to be injected, the diabetic animal handled the sugar in nearly a normal manner.⁶ Then the question naturally arose whether a similar pancreatic emulsion would not help the diabetic organism to dispose of its own excess sugar also.

In testing this question there were two principles which, we felt, should be followed. First, since the chemical properties of the effective substance or substances in the pancreas were unknown, it seemed necessary to avoid complicated procedures of purification; therefore, a simple water extraction with subsequent dilution with saline was adopted. Secondly, since depancreatization brings on its effect within a very short time, it appeared that normally the pancreas secretes its effective substance into the blood stream continually in very small amounts. It was therefore decided to

⁵ Murlin, J. R., and Kramer, B., *J. Biol. Chem.*, 1913, xv, 365.

⁶ Kleiner, I. S., and Meltzer, S. J., *Proc. Nat. Acad. Sc.*, 1915, i, 338.

⁷ Murlin, J. R., and Kramer, B., *J. Biol. Chem.*, 1916, xxvii, 517.

⁸ Kleiner, I. S., and Meltzer, S. J., *Am. J. Physiol.*, 1914, xxxiii, p. xvii. Kleiner, I. S., *J. Exp. Med.*, 1916, xxiii, 507.

⁹ Kleiner, I. S., and Meltzer, S. J., *Proc. Soc. Exp. Biol. and Med.*, 1914-15, xii, 58.

introduce the pancreatic preparation by the intravenous route very slowly and over an appreciable period; the results, however, might be expected to be observed during the injection and for only a few hours thereafter. These principles were followed and the results were very gratifying—in a word, the slow intravenous infusion of an aqueous pancreatic “emulsion” usually resulted in a temporary but marked decrease in the glycemia and glycosuria. The first few experiments were briefly reported in 1915.⁶ The present paper includes these experiments as well as a large number of experiments performed since the first communication.

Method.

Operation.—Total depancreatization was performed in the majority of cases. In three animals, used in the six most recent experiments, the “Allen” procedure, *i.e.* leaving a small remnant around the large pancreatic duct, was adopted. The operations were performed under ether anesthesia.

Preparation of “Emulsion”.—Fresh dog’s pancreas was bashed, mixed with three or four times its weight of sterile distilled water, and placed in the refrigerator. After a period of from 1 to 20 hours it was strained and squeezed through muslin. The fluid thus obtained was diluted with 5 volumes of sterile 0.9 per cent NaCl solution before injection. This dilute solution was faintly acid or neutral to litmus, light pink in color, and almost clear. At no stage was it filtered, nor was sodium carbonate or any other substance added. In one experiment (LP77a), Ringer’s solution was used in the extraction and also in the dilution; this did not lead to a better result. The emulsions of other tissues, used in the control experiments, were prepared in a similar manner.

Injection and Blood Sampling.—Some time before the infusion was to be given, the animals (in most of the experiments) received a small dose of morphine sulfate subcutaneously, usually about 1.5 mg. per kilo. Cannulas were then introduced under local anesthesia into a convenient vein and artery, for injection and blood sampling, respectively. In the six recent experiments no morphine was given and only one cannula (the venous) was introduced under local anesthesia (ethyl chloride). In this series

156 Pancreas Emulsions in Experimental Diabetes

the blood was drawn directly from an external jugular vein into a syringe. The urine was obtained by catheter in all cases.

Analytical Methods.—The blood sugar determinations were made by the Myers-Bailey¹⁰ modification of the Lewis-Benedict method. Glucose in the urine was estimated by a modification of the Pavy¹¹ method or by Benedict's¹² method. Hemoglobin was determined in most of the experiments by discharging 2 cc. of blood into dilute HCl (about 0.3 per cent) in a 250 cc. volumetric flask, diluting to this volume, and comparing the density of the color in a Duboseq colorimeter. The first blood sample of each experiment was used as the standard and was taken as 100 per cent for that experiment. Later the Sahli hemoglobinometer was used and, to avoid confusion, the results are similarly expressed.

Four illustrative protocols, including three injections of pancreas emulsion and one control, follow.

Experiment LP72a.—From Table I it will be observed that the high blood sugar value of 0.31 per cent fell to 0.14 per cent in the course of the 78 minute injection period and after another period of 90 minutes it was still low (0.13 per cent). Both of these figures, 0.14 and 0.13 per cent, are practically normal values, but emphasis is to be placed on the extent of the drop, from 0.31 to 0.13 per cent, a fall of 0.18 per cent, rather than upon the absolute value finally obtained. At the same time this decrease in the concentration of the blood sugar is not accompanied by any change in the hemoglobin value, or by an increased glycosuria. In other words it is not due to a dilution of the blood sugar by the injection fluid, or to a washing out of the sugar through the kidneys. In fact the kidney excretion of sugar is greatly diminished.

This was one of the few experiments in which the injection produced any noticeable general symptoms; there was first a fall and then a rise in temperature. There was no marked harmful effect of the infusion, however, as the animal was given a second infusion 2 days after the first and lived 2 days after that. The second infusion caused only a slight fall in the glycaemia (see LP72b in Table V).

¹⁰ Myers, V. C., and Bailey, C. V., *J. Biol. Chem.*, 1916, xxiv, 147.

¹¹ To be published shortly.

¹² Benedict, S. R., *J. Biol. Chem.*, 1911, ix, 57.

TABLE I.

*Experiment LP72a.**Male, 11.25 Kilos, Completely Depancreatized April 19, 1915.*

Date.	Time.		Blood sugar.	Hemoglobin in per cent of first sample.	Urine.			Temperature. °C.
					Volume.	Glucose.		
	<i>a.m.</i>		<i>per cent</i>		<i>cc.</i>	<i>per cent</i>	<i>gm. per hr.</i>	
Apr. 20	10.00	Injected 1.5 mg. of morphine sulfate per kilo subcutaneously.						
	10.23							39.1
	10.36	Cannulas have been introduced into left external jugular vein and right carotid artery under ethyl chloride and cocaine hydrochloride.						
	11.08				20	10.08		
	11.11		0.31	100				
	11.15	Injected intravenously						
	12.33	112 cc. of dilute pancreas emulsion prepared from the pancreas of this dog.						
	11.23	Cheyne-Stokes respiration during most of injection.						
	<i>p.m.</i>							
	12.34		0.14	101				37.9
	12.44				31.5	8.79	1.85	
	12.48							38.8
	1.00	Slight tremors of muscles of head and hind legs.						
	1.18							40.3
	1.35	Tremors have stopped.						
2.04		0.13	100					
2.15				42.5	1.62	0.46		
2.18							40.8	
<i>a.m.</i>								
Apr. 21	9.45	Not catheterized.			193	1.49		39.3

158 Pancreas Emulsions in Experimental Diabetes

Experiment LP76.—In Experiment LP76 (Table II), in spite of an intense hyperglycemia and glycosuria the administration of

TABLE II.

Experiment LP76.

Female, 9 Kilos, Completely Depancreatized May 11, 1915.

Date.	Time.		Blood sugar.	Hemoglobin in per cent of first sample.	Urine.			Temperature.	
					Volume.	Glucose.			
	<i>a. m.</i>		<i>per cent</i>		<i>cc.</i>	<i>per cent</i>	<i>gm. per hr.</i>	<i>°C.</i>	
May 12	10.15							38.5	
	10.40	Injected 1.4 mg. of morphine sulfate per kilo subcutaneously.							
	11.06	Cannulas have been introduced into left external jugular vein and left carotid artery under ethyl chloride and cocaine hydrochloride.							
	11.07	Catheterized.			111	+++			
	11.20							38.0	
	11.43				20.5	11.16	3.82		
	11.45			0.33	100				
	11.49	Injected intravenously							
	12.52	112 cc. dilute pancreas emulsion prepared from the pancreas of this dog.							
		<i>p. m.</i>							
		12 53				30	12.38	3.18	
		12 54		0.25	101				39.0
	1 13				14	3.64	0.33		
	2 27							39.5	
	2 29		0.23	103					
	2 43								

pancreatic emulsion reduced the blood sugar and urine sugar to a marked degree, (0.10 per cent), without producing any unfavorable symptoms or affecting the temperature very much. 2 days

later a different type of experiment was performed on this animal, after which it was killed with chloroform.

Experiment DP1a.—Experiment DP1a (Table III) was one of the more recent ones. No morphine was used and only an in-

TABLE III.

Experiment DP1a.

Female, 8.4 Kilos, 92 Per Cent of the Pancreas Removed on April 7, 1919, the Remnant Left Being in Communication with the Large Duct.

Date.	Time.		Blood sugar.	Hemoglobin in per cent of first sample.	Urine.			Temperature.
					Volume.	Glucose.		
			per cent		cc.	per cent	gm. per hr.	°C.
Apr. 8	a. m.							
	10.20		0.20	100				
	10.36	Catheterized.				1.25		
	11.19							38.8
	11.30	Under ethyl chloride a cannula has been inserted in the right external jugular vein.						
	11.33		0.21	102				
	11.43				16	8.0	1.15	
	11.49	Injected intravenously						
	12.31	60 cc. of dilute pancreas emulsion prepared from the pancreas of this dog.						
	p. m.							
	12.36		0.12	102				
	12.44				10	5.40	0.53	
2.15		0.08	96					
2.23				14	0.5	0.04		
2.26							40.4	
Apr. 9	a. m.							
	10.08		0.27	99	800	0.33	0.20	
	10.20	Catheterized.			20	3.62		
	10.26							38.5

jection cannula was introduced into a vein. The animal was kept on the board only during the necessary experimental procedures. The infusion of pancreas emulsion in this case caused no unfavorable symptoms and had a very striking effect on the glycemia.

160 Pancreas Emulsions in Experimental Diabetes

Before injection there was a constant and moderate hyperglycemia (0.20 and 0.21 per cent). At the end of the injection, the blood sugar had fallen to 0.12 per cent, practically a normal figure, and 1 hour and 39 minutes later the distinctly normal value, 0.08 per cent, was found. On the next morning hyperglycemia had again been established. The urinary sugar record is also of interest.

TABLE IV.

Experiment LP81a.

Male, 14.25 Kilos, Depancreatized June 7, 1915, at least 94 Per Cent of the Pancreas Removed.

Date.	Time.		Blood sugar.	Hemoglobin in per cent of first sample.	Urine.			Temperature.
					Volume.	Glucose.		
			per cent		cc.	per cent	gm. per hr.	°C.
June 8	a. m.							
	10.35	Injected 1.5 mg. of morphine sulfate per kilo subcutaneously.						
	11.19	Cannulas have been introduced into the left carotid artery and right jugular vein under ethyl chloride.						
	11.24							37.8
	11.43	Catheterized.			116	5.96		
	11.52		0.34	100				
	11.56	Injected intravenously						
	12.39	114 cc. of dilute emulsion of normal dog's submaxillary gland.						
	p. m.							
	12.41		0.32	95				
	1.08							38.3
	2.14		0.33	94				
	2.38				100	3.32	1.14	

The excretion of 1.15 gm. of glucose per hour before the injection was followed by a diminution to half that figure during the injection and thereafter only traces were excreted for at least an hour and a half (0.04 gm. per hour). The over night urine also contained very little sugar (0.2 gm. per hour) but it is evident that the kidney was not rendered permanently impermeable to

sugar because the next urine obtained by catheter contained 3.62 per cent dextrose.

On the following day (see DP1b in Table V) an injection of another pancreas preparation lowered the blood sugar from 0.27 to 0.20 per cent. The urinary sugar excretion was diminished very markedly; in one period no qualitative reaction whatever could be obtained.

Experiment LP81a.—In Table IV is given an outline of Experiment LP81a, one of the control experiments. The animal received an intravenous injection of submaxillary gland emulsion. The slight decrease in the blood sugar percentage is in marked contrast with the results obtained when pancreas emulsion was used, and runs parallel with the hemoglobin; *i.e.*, here what little effect there is may be referred to dilution by the intravenous injection of 114 cc. of fluid. The urinary data are insufficient in this experiment but indicate a possibly diminished output of sugar.

There were no noticeable general effects caused by the infusion and on the next day the administration of pancreatic emulsion lowered the blood sugar from 0.38 to 0.24 per cent (see LP81b, Table V).

In Table V all the experiments with pancreas emulsions are collected. It will be seen that in most of them there occurred a substantial reduction in the blood sugar. As the samples were not taken at short intervals it is quite probable that the lowest values were not discovered. However, normal or nearly normal figures were found in several cases. Study of the table indicates that, when effective, the emulsion produces an effect during the slow injection, because the blood sugar is usually lower at the end of the injection than at the beginning. The glycemia remains low or continues to fall for about $1\frac{1}{2}$ to $1\frac{3}{4}$ hours, and then, if we may trust the few figures at hand, it gradually rises. It is certain that the effect does not last many hours, for in a number of the experiments a sample of blood was taken on the following morning and invariably showed a hyperglycemic value.

In all except one experiment (LP75), there occurred a diminution in the excretion of sugar. In some cases this was quite marked, resulting in a urine reacting negatively to Benedict's qualitative test. Such urines, however, had normal color and specific gravity. In about half the experiments there was a

TABLE V.
Injection of Pancreatic Emulsions into Depancreatized Dogs.

Experiment N.	Blood sugar.				Sugar output in urine per hour.				Emulsion pre- pared from pan- creas of same or different animal.	Remarks.
	Before in- jection.		After in- jection.		Dur- ing in- jection.	After injection.				
	per cent	per cent	per cent	per cent		gm.	hrs.	gm.		
LP70	0.28	0.09	92	0.08	0.92	1.5	Tr.	1.4	Different.	This dog used for other experiments on pre- ceding day and again 5 days later. Slight symptoms produced by injection (see protocol, Table I). Used 2 days later for Experiment LP72b.
LP72a	0.31	0.14	91	0.13	1.85	1.50	46	42.5	Same.	
LP72b	0.28	0.22	93	0.22	0.88	1.40	61	15	"	No symptoms.
LP73	0.33	0.25	71	0.16	→	0.8	+	5*	"	Dog died 50 min. after end of injection; heart blood obtained 21 min. later. Peritonitis; perhaps 25 per cent of pancreas not re- moved.
LP74a	0.27	0.21	93	0.18	5.07	1.60	66	9	"	Used 4 days later for Experiment LP74b.
LP74b	0.23	0.18	92	0.13	1.54	1.50	0.07	5.5	Different.	Dog used on the next day for another ex- periment.
LP75	0.27	0.22	101	0.23	1.14	1.81	55	34	"	Killed 3 days later; about 8 per cent of pan- creas not removed.
LP76	0.33	0.25	97	0.23	3.20	1.60	32	14	Same.	Used this dog 2 days later for another ex- periment.
LP77a	0.21	0.17	95	0.16	0.66	1.60	0.05	23	"	Ringer's solution used in preparing emul- sion; pregnant animal; used 6 days later for LP77c.
LP77c	0.24	0.25	90	0.22	→	1.50	2*	23.5*	Different.	Dog used 6 days before for LP77a, and 4 days before for LP77b (Table VI).

LP81b	2	0.38	0.26	90	0.24	1.79	1.70	0.09	22.5	Different.	Received injection of submaxillary emulsion on preceding day (Experiment LP81a, Table VI); killed 2 days later; perhaps 6 per cent of pancreas not removed.
DPI a†	1	0.20 0.21	0.12	104	0.08	1.16	1.70	0.04	14 20	Same.	"Allen" procedure; 8 per cent of pancreas left; used 2 days later for Experiment DPIb.
DPI b†	3	0.25 0.27	0.21	94	0.20 240	>1.15	2.20	0.00	60 65	Different.	Killed on following day.
DP2 a†	2	0.31 0.30	0.24	107	0.19	1.00	1.70	0.04	38 18	Same.	"Allen" procedure; 4 per cent of pancreas left; used 3 days later for Experiment DP2b.
DP2 b†	5	0.30 0.33‡	0.26	81	0.17 164	1.20	1.10	0.00	26 83	Different.	Had been used 3 days before for Experiment DP2a; used 3 days later for Experiment DP2c.
DP2 c†	8	0.33	0.29	140	0.26 246	1.85 (24 hrs.)	2.00	0.00	39 66	Same.	Had been used for Experiments DP2 a and b.

* During and after injection.

† No morphine given.

‡ After feeding.

164 Pancreas Emulsions in Experimental Diabetes

TABLE VI.
Injections of Emulsions of Tissues, Other than Pancreatic, into Depancreatized Dogs.

Experiment No.	Days after operation.	Blood sugar.			Sugar output in urine per hour.			Tissue used for emulsion.	Remarks.			
		Before injection.		After injection.		During injection.	After injection.					
		per cent.	per cent.	min.	per cent.					gm.	cc.	
LP77b	3	0.23	0.26	92	0.28	1.07	→	1.8	0.15*	23.5*	Submaxillary gland.	Had been used 2 days before for Experiment LP77a; used 4 days later for Experiment LP77c see Table V); pregnant. Used on the following day for Experiment LP81b (Table V); perhaps 6 per cent of pancreas not removed. Required 4.2 mg. of morphine per kilo; considerable depression; died during night; cause of death could not be found at autopsy; 4 per cent of pancreas not removed. Killed on following day. Died 3 days later of pulmonary edema. "Allen" type; at time of this experiment glycosuria was not marked; had been used 4 days before for another experiment; chloroformed 6 weeks later; no morphine used.
LP81a	1	0.34	0.32	95	0.33	→	→	2.0	1.14*	100*	"	
LP81	1	0.31	0.31	92	0.36	→	→	1.8	0.08*	2.2*	"	
LP86	1	0.39	0.37	92	0.42	1.9	→	1.8	0.27*	11*	"	
LP83	1	0.41	0.36	101	0.35	4.75	→	1.7	2.12	28	Spleen.	
DP3†	5	0.31	0.32	114	0.32	0.28	→	3.0	0.20	26	Voluntary muscle.	
				193	0.32			21.5	>1.9	830		

*During and after injection.

†No morphine given.

Decided reduction in the volume of urine secreted in the 1½ hour period following the injection, indicating perhaps some temporary functional damage to the kidney; it is possible that this may be caused by the injection of any tissue extract. In the rest of the experiments there was no diminution in urinary flow even when the sugar output had practically ceased (see Experiments LP77a, DP1 a and b, DP2 a, b, and c, Table V).

The controls in which emulsions of several other tissues were injected are tabulated in Table VI. There was no marked effect

TABLE VII.

*Summary.**Maximum Reduction of Blood Sugar Produced by Injection of Tissue Emulsion.*

Marked reduction.			Moderate or no reduction.		
Experiment No.	Maximum reduction of blood sugar.	Kind of emulsion.	Experiment No.	Maximum reduction of blood sugar.	Kind of emulsion.
LP70	0.20	Pancreas.	LP72b	0.06	Pancreas.
LP72a	0.18	"	LP75	0.05	"
LP73	0.17	"	LP77a	0.05	"
LP74a	0.09	"	LP77c	0.02	"
LP74b	0.10	"	DP1b	0.07	"
LP76	0.10	"	DP2c	0.07	"
LP81b	0.14	"	LP77b	Increase.	Submaxillary gland.
DP1a	0.13	"	LPS1a	0.02	" "
DP2a	0.11	"	LPS4	Increase.	" "
DP2b	0.16	"	LPS6	0.02	" "
			LPS3	0.06	Spleen.
			DP3	Increase.	Muscle.

on the blood sugar in any of these tests. Injection of emulsion of spleen (Experiment LP83) was followed by a slight fall of blood sugar, from 0.41 to 0.35 per cent; this was the maximum effect observed in any of the controls. Indeed a slight increase in the blood sugar was observed in three experiments. The amount of sugar eliminated by the kidney was usually decreased to some extent, but not so much as in the pancreas injection experiments. In none of these controls, for instance, was a negative or weak Benedict's test obtained and it is probable that in some of these, as in many of the pancreas emulsion experi-

ments, we have to do with an impairment of the renal epithelium. The striking point in these six experiments is the regular failure to observe a marked lowering of the blood sugar as contrasted with the success when pancreas emulsion was used.

This difference is brought out in the summary (Table VII). Here it will be observed that ten out of sixteen pancreas emulsion injections resulted in a marked reduction of the blood sugar, the greatest reduction in each case falling in the range 0.09 to 0.20 per cent. The other six pancreas experiments, as well as all the controls, showed a reduction of only 0.07 per cent or less. Only one of all the sixteen pancreas experiments had practically a negative result (LP77c), while only one of the controls showed anything resembling a positive effect (LP83).

DISCUSSION.

Many investigators¹³ have recognized that the best evidence for the internal secretion theory of the origin of diabetes would be an antidiabetic effect of a pancreatic preparation, administered parenterally. The experiments just described show that such a result has been obtained, since the reduction of hyperglycemia is surely an antidiabetic effect, and the reduction of glycosuria is possibly partly of the same nature. The demonstration of the actual combustion of sugar has not been attempted although the additional proof, while not absolutely essential, would be welcome. A favorable effect upon the glycemia and glycosuria has, however, been established and there remain only a few points to be considered.

The reduction in glycemia is real, that is, it is not due to dilution. The hemoglobin values, given in the protocols, indicate that this is the case; the same holds true for all the pancreas injection experiments, although this has not been recorded in Table V. Furthermore, that it is not an accident, a mere coincidence, is proven by the fact that it occurred to a marked degree in ten out of sixteen experiments, and to some extent in fifteen out of sixteen. The controls include only one with any effect—and that an insignificant one—on blood sugar. In some cases

¹³ See, for example, Hédon, E., *Travaux de Physiologie*, Paris, 1898, 133. Pflüger, E., *Arch. ges. Physiol.*, 1907, cxviii, 271.

The pancreas emulsion injection resulted in changing a pronounced hyperglycemia to a normal blood sugar. It is quite likely that more of these cases occurred than were discovered, because the blood samples were not taken at short intervals.

No increased glycosuria occurred which could be said to account for the decrease in blood sugar. On the contrary, the elimination of sugar was decreased in every experiment except one, this being one in which the effect on the blood sugar was slight (Experiment LP75, Table V). The effect upon the urinary sugar generally lasted longer than that upon the blood sugar, but specimens of urine obtained by catheterization on the day following the injection usually contained high percentages of sugar. This would indicate that if the injection of an organ extract decreases the permeability of the kidney to sugar by a toxic action, the effect is only temporary. Since in the controls a similar, but less marked, transitory reduction of the urinary sugar output was observed, it is evident that *the mere reduction of glycosuria is no proof of a beneficial effect of any agent*. Observations of other investigators may be cited in this connection. Murlin and Kramer⁵ in one experiment found that an intravenous injection of a mixed boiled extract of pancreas and duodenal mucosa produced a marked fall in the sugar output of a diabetic dog, but that there was a rise in the blood sugar. Hédon¹⁴ has shown that transfusion of normal blood into diabetic animals may result in a diminished output of sugar with little if any reduction of the blood sugar level. He assumes that the diabetic complex consists of two phases, of which the renal is the first to be affected by the internal secretion of the pancreas. Is it not possible, however, that the introduction of a foreign blood had a toxic effect on the kidney? In fact Hédon himself admits that cross circulation between two diabetic dogs also diminishes glycosuria. The same criticism applies to all blood transfusion and related investigations^{15, 16} in

¹⁴ Hédon, E., *Compt. rend. Soc. biol.*, 1911, lxxi, 124.

¹⁵ Forschbach, J., *Arch. exp. Path. u. Pharmacol.*, 1908-09, lx, 131. This author united animals of the same litter (parabiosis) and later removed the pancreas of one, without causing more than a mild glycosuria. In one experiment (No. 5, p. 145) he reports a blood sugar of 0.32 per cent while the urine was sugar-free.

¹⁶ Drennan, F. M., *Am. J. Physiol.*, 1911, xxviii, 396.

which only the urine was examined. The same question might be asked regarding Scott's work,⁴ for he, too, used only the urinary output as an index of the action of his pancreatic extract.

It must be emphasized that the beneficial effects of the pancreas emulsion are not to be referred to sodium carbonate or any other alkali. *No alkali was used in preparing the pancreas emulsions.* The extractions were made with water and the dilutions of the extract, or emulsion, with 0.9 per cent NaCl. The resulting injection fluid was faintly acid to litmus. Our experiments, therefore, cannot be compared with Murlin and Kramer's^{5,7} because they always used an alkaline medium. The alkalinity itself is, according to these authors, largely responsible for the beneficial action of the various tissue extracts which they administered. In our experiments, on the other hand, the favorable effect of the pancreatic emulsion must be due to some ingredient peculiar to it, because no alkali was used in its preparation, and because the other tissue emulsions, prepared in a similar manner, had no such favorable effects.

The mechanism of the effect on the blood sugar may be considered briefly. There are several possibilities, corresponding to the several hypotheses for the mechanism of diabetes. The author does not wish to enter here into an extended discussion of these hypotheses, but wishes to point out how the results of this investigation apply in each case. For the "overproduction" theory the injection fluid may be held to contain a substance which decreases the output of sugar by the liver. If one believes that, in diabetes, the cells themselves lack the power to burn sugar—as many investigators do—it will be said that the pancreas emulsion contains the substance which stimulates the cells to this activity, or the "amboceptor" (Allen) which enables the cells to anchor sugar to their protoplasm.

Kleiner and Meltzer¹⁷ have indicated another explanation for some of the phenomena of diabetes; *i.e.*, a decreased permeability to sugar of the capillary endothelia and perhaps of other cells as well. Palmer¹⁸ has corroborated this by showing that the striated muscle of diabetic animals has a lower concentration of glucose

¹⁷ Kleiner, I. S., and Meltzer, S. J., *Proc. Soc. Exp. Biol. and Med.*, 1914-15, xii, 58.

¹⁸ Palmer, W. W., *J. Biol. Chem.*, 1917, xxx, 79.

than that of normal animals, if the respective levels of blood sugar are taken into account. We have also reported that pancreas emulsions enable diabetic animals to handle, in a nearly normal manner, large amounts of intravenously administered dextrose. This was taken to mean that the pancreas emulsion had restored the permeability, thus permitting the sugar to be absorbed and taken care of in the normal manner. The same explanation may be applied to the present experiments. In other words the pancreas emulsion perhaps contains some substance which alters the permeability of the capillary walls, allowing the diabetic sugar to go through them into the tissues. Another factor which may come into consideration is the state of the blood sugar. The author has presented evidence¹⁹ that the diabetic blood sugar is in a combined or poorly diffusible state. This indicates a further difficulty presented to the diabetic organism in its struggle to obtain sugar for its starving tissues. The enzymes present in the pancreas emulsion may be able to break up this combination setting free crystalloid glucose. This can diffuse readily through the tissues which at the same time have been rendered more permeable to it. This last possibility may be tested directly by the method already described.¹⁹

The question of the general toxicity of the extracts used requires a few words. It might be expected that an unfiltered tissue extract of this sort would produce grave symptoms when injected intravenously. This was not the case, however. The explanation seems to be that the extract was highly diluted and very slowly injected. In but few instances among the entire list of experiments was any depression or other unfavorable symptom observed. Furthermore, most of the animals received several infusions on different days and survived them. One dog died shortly after a pancreas emulsion injection, but death was apparently due to peritonitis. One control died a few hours after the injection of submaxillary emulsion, and another died of pulmonary edema 3 days after spleen emulsion had been administered.

The fact that these pancreas emulsions lower blood sugar in experimental diabetes without causing marked toxic effects indicates a possible therapeutic application to human beings. It is

¹⁹ Kleiner, I. S., *J. Biol. Chem.*, 1918, xxxiv, 471.

170 Pancreas Emulsions in Experimental Diabetes

true that the numerous attempts at pancreas therapy have been almost uniformly unsuccessful. However, the methods heretofore used have not resembled the one used in our experiments. This method is based on certain principles, discussed early in this paper, and is extremely simple. It is possible that the temporary effect which it produced in dogs might be duplicated in man and might be useful in certain emergencies. However, it is doubtful whether attempts along this line should be made until further knowledge has been obtained. It is important to know whether a filtered extract would be effective; and particularly whether an emulsion of the pancreas of another species would have its effect when injected into a diabetic dog. Other questions also arise. Do such injections raise the respiratory quotient? Could other paths of injection and other animals be used equally well? Finally the search for the effective agent or agents, their purification, concentration, and identification are suggested as promising fields for further work.

SUMMARY.

Diabetic dogs were given intravenous injections of unfiltered water extracts of fresh pancreas, diluted with 0.9 per cent NaCl solution. The preparation was administered very slowly and usually resulted in a marked decrease in the blood sugar. There was no compensating increase in urinary sugar, but rather a decrease, which may be partly due to a temporary toxic renal effect.

The result is regarded as further evidence for the internal secretion theory of experimental diabetes.

CRYSTALLINE GUANYLIC ACID.

By P. A. LEVENE.

(From the Laboratories of The Rockefeller Institute for Medical Research.)

(Received for publication, September 30, 1919.)

The theory of the polynucleotide structure of the yeast nucleic acid has been receiving confirmation in recent years through the investigations of several workers. Levene,¹ Jones and Kennedy,² and Thannhauser and Dorfmueller³ have described crystalline mononucleotides obtained from yeast nucleic acid. The present communication contains a report on guanylic acid obtained in crystalline form. It crystallized in the form of long prismatic needles having the same appearance as guanosine. The substance had all the properties of guanylic acid. It gelatinized in the presence of mineral impurities. A test for the presence of free phosphoric acid was negative. It had no melting point but turned brown at 208°C. The optical rotation in water solution was $[\alpha]_D^{20} = -7.5$, and in a 5 per cent ammoniacal solution $[\alpha]_D^{20} = -43.5$. On hydrolysis it gave guanosine or guanine sulfate depending on the conditions of the experiment. The free acid, when air-dry, crystallized with 2 mols of crystal water, and, when dried under diminished pressure at the temperature of a toluene vapor bath to constant weight, still retained $\frac{1}{2}$ mol of crystal water. The pure guanylic acid was converted into a crystalline brucine salt.

EXPERIMENTAL.

Crude brucine salt of guanylic acid was converted into the ammonium salt in the manner described in a previous publication.⁴ The ammonium salt was dissolved in hot water. The resulting

¹ Levene, P. A., *Proc. Soc. Exp. Biol. and Med.*, 1917-18, xv, 21.

² Jones W., and Kennedy, R. P., *J. Pharmacol. and Exp. Therap.*, 1919, xii, 253.

³ Thannhauser, S. J., and Dorfmueller, G., *Z. physiol. Chem.*, 1919, civ, 65.

⁴ Levene, P. A., *J. Biol. Chem.*, 1919, xxxix, 47.

solution was acidulated, and the substance precipitated by means of neutral lead acetate. The precipitate was repeatedly washed with water, then suspended in water, and freed from lead. The resulting solution was again precipitated with neutral lead, and the process repeated once more. Finally the solution obtained on decomposition of the lead salt gave on concentration under diminished pressure a crystalline deposit.

On drying under diminished pressure at the temperature of xylene vapor, the substance still retained $\frac{1}{2}$ mol of crystal water.

0.1084 gm. of the vacuum-dry substance gave 0.1274 gm. of CO_2 and 0.0424 gm. of H_2O .

0.1834 gm. of the substance used for Kjeldahl nitrogen estimation required 24.45 cc. of 0.1N acid for neutralization.

0.2757 gm. of the substance gave 0.0844 gm. of $\text{Mg}_2\text{P}_2\text{O}_7$.

	Calculated for $\text{C}_{10}\text{H}_{14}\text{N}_5\text{O}_8 + \frac{1}{2}\text{H}_2\text{O}$.	Found.
	per cent	per cent
C.....	32.24	32.05
H.....	4.03	4.38
N.....	18.80	18.67
P.....	8.33	8.55

In 10 per cent hydrochloric acid the substance was optically inactive. In aqueous solution the rotation was

$$[\alpha]_{\text{D}}^{20} = \frac{-0.15 \times 100}{1 \times 2} = -7.5$$

In 5 per cent aqueous ammonia solution the rotation was

$$[\alpha]_{\text{D}}^{25} = \frac{-0.87 \times 100}{1 \times 2} = -43.5$$

Acid Hydrolysis of the Substance.

2.0 gm. of the substance were dissolved in 20.0 cc. of 2 per cent sulfuric acid and boiled over a flame with a return condenser for 1 hour. The substance was filtered and allowed to cool. Soon a crystalline deposit formed. This was filtered and recrystallized out of 5 per cent sulfuric acid. The substance was dried over night over sulfuric acid in a vacuum desiccator.

0.0905 gm. of dry substance gave 27.6 cc. of nitrogen gas at $T^{\circ} = 25^{\circ} \text{C}$ and $P = 763$.

	Calculated for $(\text{C}_5\text{H}_7\text{N}_3\text{O})_2\text{H}_2\text{SO}_4$.	Found.
	per cent	per cent
N.....	35.00	35.08

Ammonia Hydrolysis.

2.5 gm. of the substance were dissolved in 50 cc. of water containing 5 cc. of ammonia water, and the solution was made up to 75 cc. It was then heated in a sealed tube for 4 hours at 135°C . On cooling, the contents of the tube practically solidified. The solid material was filtered on suction and the residue recrystallized twice out of water. The crystals had the characteristic appearance of guanosine. The yield of the recrystallized substance was 0.6 gm.

0.100 gm. of the substance employed for Kjeldahl nitrogen estimation required for neutralization 8.8 cc. of 0.1N acid.

	Calculated for $\text{C}_{10}\text{H}_{13}\text{N}_5\text{O}_5 \cdot 2\text{H}_2\text{O}$.	Found.
	per cent	per cent
N.....	21.94	21.98

The rotation of the substance was

$$[\alpha]_{\text{D}}^{20} = \frac{-0.66 \times 100}{1 \times 1} = -66.0$$

Since this rotation was slightly higher than the one previously recorded (-60.5), and since in the earlier work a less sensitive instrument was employed for the measurement, the rotation of a pure sample of guanosine was measured under exactly the same conditions as the sample obtained in the present work. The value obtained was

$$[\alpha]_{\text{D}}^{20} = \frac{-0.66 \times 100}{1 \times 1} = -66.0$$

Brucine Salt.

2 gm. of the crystalline guanlylic acid were dissolved in water and neutralized by means of a solution of brucine in methyl alcohol. A crystalline deposit formed immediately. This was

filtered off and recrystallized out of a 35 per cent solution of alcohol in water. The air-dry substance contracted at 217° (Anschutz thermometer), melted into a brown liquid at 233°, and effervesced at 240°C.

0.1000 gm. of the substance gave on combustion 0.1938 gm. of CO₂ and 0.0558 gm. of H₂O.

0.2000 gm. of the substance gave 18.2 cc. of nitrogen gas at T° = 25° and P = 759.

0.300 gm. of the substance gave 0.262 gm. of Mg₂P₂O₇.

	Calculated for C ₃₅ H ₆₁ N ₉ O ₁₆ ·7H ₂ O. <i>per cent</i>	Found. <i>per cent</i>
C.....	52.61	52.85
H.....	6.78	6.24
N.....	9.88	10.41
P.....	2.43	2.43

The rotation of the substance in 35 per cent alcohol solution was

$$[\alpha]_{\text{D}}^{20} = \frac{-0.52 \times 100}{1 \times 2} = -26.0$$

A NEW STEROL.

BY TAKEO IKEGUCHI.

(From the Medical-Chemical Institute of the Medical College of Osaka, Japan.)

(Received for publication, September 17, 1919.)

The sterols are probably contained in all cells, and there seems to be no doubt of their importance physiologically. Until now, however, the only property which has been conclusively proved is their antidotal effect toward the hemolytic action of the saponins.

If we take into account the poisonous action of some of the sterol derivatives upon the tissues of the heart, the biological significance of sterol affords an interesting field for research.

Whereas cholesterol, which is commonly found in animals, has received much attention, and its structure has been practically confirmed by Mauthner, Abderhalden, and especially by Windaus,¹

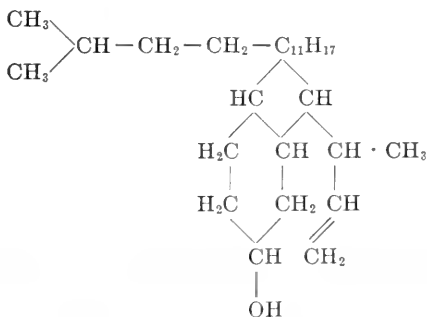

the other members of the sterol group, which occur in plants and fungi, have received but slight consideration.

Several varieties of sterol have been isolated from fungi. Tanret² obtained ergosterin and fungisterin from ergot; and Zellner³ separated a sterol, with the formula $\text{C}_{25}\text{H}_{46}\text{O}$, from the

¹ Windaus, A., *Ber. chem. Ges.*, 1912, xlv, 2421.

² Tanret, quoted by Windaus, A., in Abderhalden, E., *Biochemisches Handlexikon*, Berlin, 1911, iii, 309.

³ Zellner, J., quoted by Fodor-Halle, A., in Abderhalden, E., *Biochemisches Handlexikon*, Berlin, 1914, viii, 493.

toadstool. Up to the present, however, no one appears to have separated one identical sterol from different species of fungi, comparing it with other sterols and determining its structure. This is the reason for attempting investigation along this line.

In an earlier treatise,⁴ the writer described a sterol-like substance which he obtained from the *Lycoperdon*. During the course of the present research, he examined *Collybia shiitake*, from which he isolated another sterol in pure form. This he traced through *Armillaria elodes*, *Hydnum asparatum*, and *Lycoperdon gemmatum*.

Method of Preparation and General Tests.

100 gm. portions of each of the above mentioned fungi, dried as well as possible at room temperature, and then thoroughly in an oven at 70°C., were extracted with ether. The ether was then distilled, leaving in each case an oily residue, which soon coagulated into a cheesy mass containing the sought for crystals of sterol. The crystals were washed with petroleum ether and alcohol, and then recrystallized from a hot solution of the latter solvent. Each batch of fungi, treated in this manner, yielded about 0.1 gm. of long, colorless, hexagonal crystals.

All the crystals obtained gave the same color reactions. (1) The crystals were dissolved in chloroform; an equal volume of concentrated sulfuric acid was then carefully added so as to form a separate layer. From the contact surface between the two layers the lower sulfuric acid layer gradually became blood-red, while the chloroform layer turned brownish blue, there being a distinct green fluorescence in both layers. (2) To a chloroform solution of the crystals a little acetic anhydride and two drops of concentrated sulfuric acid were added. The mixture became at first rose-red, then successively blue, and dark green. (3) The crystals were dissolved in acetic anhydride. On adding a few drops of concentrated sulfuric acid the mixture turned first rose-red, then violet, then blue, and finally green. (4) The crystals do not give the oxysterol reaction.

Each of the above reactions is similar to the corresponding one for cholesterol. In the first test, however, where cholesterol is

⁴ Ikeguchi, T., *Z. physiol. Chem.*, 1914, xcii, 257.

concerned, the coloration shown by the two layers is reversed. It resembles the cholestanon⁵ reaction, but can be differentiated from the latter by the difference of color of the chloroform layer.

The crystals obtained, as indicated above, by the extraction of the various fungi are colorless and odorless and melt at 159–160°C. When exposed to the air for a long time or heated above 80°C., they become yellow in color. On ignition they emit an odor resembling that of isovaleric acid. They are readily soluble in ether, chloroform, and warm alcohol, with difficulty in cold alcohol and petroleum ether, and are insoluble in water.

In solution the substance is levorotatory. The sample to be determined was dissolved in chloroform and the measurements were made with a Landolt polariscope, using a 2 dm. tube. The specific rotation of the substances obtained from each fungus was nearly the same

Name of fungus.	Specific rotation ($[\alpha]_D^{20}$).
<i>Collybia shiitake</i>	–129.4
<i>Armillaria edodes</i>	–129.23
<i>Hydnum asparatum</i>	–129.55

and the results obtained by analysis were also nearly equal.

Name of fungus.	Weight of sample. gm.	CO ₂ gm.	H ₂ O gm.
<i>Collybia shiitake</i>	0.1464	0.4402	0.1464
<i>Armillaria edodes</i>	0.1086	0.3260	0.1110
<i>Hydnum asparatum</i>	0.1568	0.4746	0.1556

C per cent	Found. H per cent	Calculated (C ₂₀ H ₂₈ O ₂).	
		C per cent	H per cent
82.004	10.81	81.81	10.9
81.87	11.35		
82.02	10.95		

The yield of the substance obtained from the *Lycoperdon* was so small, owing to the difficulty of isolating it from other materials present, it could not be analyzed; however, there is no doubt that it is identical with others, agreeing with them in its crystal form, color reactions, and melting point.

⁵ Diels, O., and Abderhalden, E., *Ber. chem. Ges.*, 1904, xxxvii, 3099.

The sterol obtained probably occurs not only in the fungi above mentioned but throughout all classes of fungi, wherefore I shall name the compound mycoesterol.

According to the analytical results, mycoesterol may be regarded as an oxidation product of stigmasterol,⁶ and this, referring to the fact ascertained by Lifschutz that cholesterol is converted into oxycholesterol in the animal body, gives mycoesterol an added interest.

In order to ascertain whether mycoesterol is capable of preventing the hemolytic action of saponin, an experiment was carried out following Hausmann's method.⁷ 5 cc. of an ether solution of mycoesterol were gradually added with stirring to 5 cc. of saponin solution (0.1 gm. of saponin in 100 cc. of isotonic sodium chloride solution). The mixture was placed in an oven at 40°C. for 7 to 8 hours, then at 30°C. for 1 to 2 hours, after which the ether evaporated *in vacuo*. 1 and 2 cc. of the mixture thus prepared were added respectively to two 5 cc. portions of a floating solution of red corpuscles taken from a rabbit. The phenomenon of hemolysis occurred to a small extent in 24 hours, while a similar blood solution to which the saponin solution only had been added showed complete hemolysis instantaneously. Another similar solution with cholesterol in place of the mycoesterol showed no hemolysis at all even after 24 hours.

This experiment shows that mycoesterol, as well as cholesterol, is an antidote against saponin though its power is not so great.

*Digitonin Compound.*⁸—Mycoesterol was dissolved in boiling alcohol, and a 1 per cent alcohol solution of digitonin was added in excess until the mixture presented a slight turbidity. After standing for about 1 hour, crystals separated out which were filtered off, washed with alcohol and ether, and then recrystallized from methyl alcohol after adding a little water. The crystals melted at 242°C. with the evolution of gas.

The crystals are soluble in pyridine, and with difficulty in acetone and benzene. They give the typical Liebermann-Burhard reaction which serves to show that the crystals are a compound of mycoesterol and digitonin.

⁶ Windaus, A., and Hauth, A., *Ber. chem. Ges.*, 1906, xxxix, 4378.

⁷ Hausmann, W., *Beitr. chem. Physiol. u. Path.*, 1905, vi, 567.

⁸ Windaus, A., *Ber. chem. Ges.*, 1909, xlii, 244.

0.1320 gm. of substance (dried at 110°C.) gave 0.2998 gm. of CO₂ and 0.1034 gm. of H₂O.

Found.		Calculated (C ₂₃ H ₄₂ O ₃).	
C	H	C	H
per cent	per cent	per cent	per cent
61.94	8.70	62.119	8.64

According to Hausmann and Abderhalden, a sterol, containing an hydroxyl group and a double-bond in its molecule, is capable of preventing hemolysis by saponin, and when the hydroxyl group is replaced by another atom or group, or linked with such an atom or group, as is the case in an ether, its action disappears. If the double-bond is saturated, its action becomes weaker than that of the initial material. Referring to this conclusion, mycosterol probably contains a free hydroxyl group, but does not contain a double-bond. To test these assumptions the following experiments were carried out.

Acetylation.—In a small flask fitted with a condenser, 0.5 gm. of mycosterol and twenty times its volume of acetic anhydride were boiled gently on a sand bath for 5 hours. After standing, the crystals which precipitated out were filtered off, washed with acetic acid, and recrystallized from ether, melting at 169°C.

0.1524 gm. of substance gave 0.4448 gm. of CO₂ and 0.1504 gm. of H₂O.

Found.		Calculated (C ₂₂ H ₃₂ O ₃).	
C	H	C	H
per cent	per cent	per cent	per cent
79.59	10.96	79.66	10.37

Bromination.—0.123 gm. of mycosterol was dissolved in 5 cc. of ether and to this solution a bromoacetic acid mixture was added. The ether was then allowed to evaporate spontaneously, leaving colorless needle-shaped crystals. The melting point, color reaction, and solubilities agreed with those of mycosterol; therefore, the crystals may be considered to be the unchanged mycosterol.

It is evident from the above experiments that mycosterol contains at least one free hydroxyl group in its molecule, but does not contain a double-bond which can be tested by the methods above mentioned.

With regard to the manner in which the other atom of oxygen is linked up in the molecule of mycosterol, there are several possibilities. Reasoning from the oxidation products of cholesterol, however, the carbonyl group or hydroxyl group

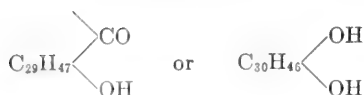

is most probably to be taken into account. Since mycoesterol, when treated with phenylhydrazine, does not form a phenylhydrazone, it may be concluded that it does not contain the carbonyl group for which this is a test. If the oxygen may exist as a carbonyl group it should be in a state which cannot be readily acted upon by phenylhydrazine, as oxycholesterol, obtained by Mauthner⁹ oxidizing cholesterol, does not readily form a phenylhydrazone, though containing the carbonyl group.

0.5 gm. of phenylhydrazine hydrochloride and 0.5 gm. of sodium acetate were added to 1 gm. of mycoesterol dissolved in warm alcohol. The mixture was heated for 1 hour on a water bath under a reflux condenser. Upon cooling crystals precipitated, which were filtered off by means of suction, washed with alcohol, and recrystallized from warm alcohol. The crystal form and the melting point were in agreement with those of mycoesterol, and as the compound contains no nitrogen, it must be mycoesterol itself.

Oxidation of Mycoesterol.—As has already been shown, mycoesterol has one hydroxyl group, which is verified by the action of acetic anhydride. Therefore, if the other oxygen exists as a hydroxyl group, it must be in a form which cannot be detected by acetylation, as is often the case with a tertiary alcohol group.¹⁰ The decision between the two possibilities can be made by examining the oxidation products of mycoesterol. On treatment of mycoesterol with chromic acid it yielded three different neutral crystalline products and an analysis of the substance of which the largest amount was obtained agreed with the compound $\text{C}_{30}\text{H}_{48}\text{O}_3$.

5 gm. of chromic acid dissolved in 10 cc. of acetic acid were carefully added to 10 gm. of mycoesterol which were suspended in 100 cc. of acetic acid. The mixture was heated on a water bath until it was deep green. The resultant solution was poured into a diluted sodium chloride solution, the whole then extracted with ether. The ether layer was treated with sodium chloride solution, then with sodium hydroxide solution to remove acid substances.

⁹ Mauthner, J., and Suida, W., *Monatsh. Chem.*, 1896, xvii, 582.

¹⁰ Diels, O., and Abderhalden, E., *Ber. chem. Ges.*, 1903, xxxvi, 3178.

The oily residue mixed with crystals formed on evaporation was washed with petroleum ether and benzene and recrystallized from acetone, melting at 188–189°C.

This substance is soluble in acetone, alcohol, and chloroform, and insoluble in water.

0.118 gm. of substance (dried at 105°C.) gave 0.3404 gm. of CO₂ and 0.1168 gm. of H₂O.

C per cent	Found.		Calculated (C ₃₀ H ₄₆ O ₃).	
	H per cent		C per cent	H per cent
78.67	10.99		78.94	10.53

According to these results the oxidation product may be regarded as an additional product of one atom of oxygen and one molecule of mycoesterol, for the number of carbon and hydrogen atoms remains equal to that in mycoesterol. Considering the relation of the new oxygen toward the molecule, two possibilities may be suggested; namely, either that one of the groups containing oxygen in the molecule of mycoesterol has been converted into a carbonyl group by the addition of one oxygen, or that a new group containing oxygen has been formed.



Since the oxidation products are neutral, the former case is out of the question, and since the number of hydrogen atoms in the molecule of the new substance is equal to that of the original mycoesterol, the hydroxyl group and the hydrocarbon group must have remained untouched.

It is, therefore, reasonable to conclude that in the molecule of the oxidation product two out of three groups containing oxygen remain the same as in mycoesterol, while the third is a newly formed hydroxyl group. To prove this point 1 gm. of the oxidation product was mixed with twenty times its volume of acetic anhydride and boiled gently on a sand bath for 5 hours. Upon cooling, water was added until the solution became a little turbid. Long needle-shaped crystals were precipitated which were washed thoroughly with a little ligroin and recrystallized from acetic acid, melting point 201–202°C.

0.1647 gm. of substance (dried at 105°C.) gave 0.4454 gm. of CO_2 and 0.141 gm. of H_2O .

C <i>per cent</i>	Found.		Calculated ($\text{C}_{36}\text{H}_{54}\text{O}_6$).	
	H <i>per cent</i>	H <i>per cent</i>	C <i>per cent</i>	H <i>per cent</i>
73.92	9.3		74.22	9.27

The substance which was obtained by treating the oxidation product with acetic anhydride is a triacetic ester as is shown in formula (1).

From this fact it may be concluded that two atoms of oxygen in mycosterol are contained as hydroxyl groups and mycosterol may be a dihydroxyl compound and its oxidation product a trihydroxyl compound.

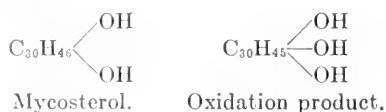

ON THE RELATIVE ACCURACY OF COLORIMETRIC AND TITRIMETRIC PROCEDURES FOR DETER- MINING NITROGEN AS AMMONIA.

BY E. R. ALLEN AND B. S. DAVISSON.

(From the Laboratories of Biological Chemistry, Washington University
Medical School, St. Louis, and the Laboratories of Soil Technol-
ogy, Ohio Agricultural Experiment Station, Wooster, Ohio.)

(Received for publication, September 30, 1919.)

INTRODUCTION.

The problems arising in connection with investigations in the field of soil biology frequently are concerned with the fixation and transformation of nitrogen and require nitrogen determinations made with greater accuracy than is the case in most other lines of work. While engaged in this field of research, we carried out a considerable number of studies on nitrogen methods. Among other points studied, the comparative accuracy of the colorimetric and titrimetric procedures for the determination of nitrogen in the ammonium form have been investigated.

In the matter of improvement and adaptation of nitrogen methods to particular fields of research, two workers, Folin in America and Mitscherlich in Germany, have been particularly active. Folin, working in the field of animal nutrition, has employed both colorimetric and titrimetric procedures and favors the former, whereas Mitscherlich, studying the problems of plant nutrition, has adhered to the titrimetric procedure. Folin and Farmer¹ used a modified Nessler-Winkler reagent in such a way that as much as 1.5 mg. of nitrogen may be determined colorimetrically without precipitation. By proper aliquoting, the quantity of nitrogen is kept below this amount.

Methods of this type have found quite wide favor, and certain modifications have been proposed from time to time by Folin and

¹ Folin, O., and Farmer, C. J., *J. Biol. Chem.*, 1912, xi, 493.

his associates. On the other hand Mitscherlich and Herz² used titration with ± 0.02 N solutions with a surprising degree of accuracy for amounts of nitrogen varying from 0.68 to 6.84 mg. However, it was not clear from the papers of these two workers which procedure was the more accurate, and therefore the work reported below on the probable error of the two procedures, as computed by the method of least squares, was carried out.

EXPERIMENTAL.

Reagents and Solutions.

Indicator Used.—The compound dimethylaminoazobenzene-*o*-carboxylic acid, or methyl red, is the most suitable indicator for the titration of weak bases as ammonia, and is extensively used at the present time. It has rightly supplanted the use of alizarine red, Congo red, cochineal, and lacmoid. Its end-point is so sharp, even in the presence of ammonia, that if proper conditions are observed very dilute solutions are titrated with ease and accuracy.

Titrimetric Standards.—Standard 0.02 N acid was prepared from pure sulfuric acid and carbon dioxide-free water, and standardized by the sodium carbonate method, which, according to Mitscherlich and Meeres,³ is the most accurate. Standard 0.02 N alkali was prepared from sodium hydroxide and carbon dioxide-free water.⁴ The titrations were made with the aid of 25 cc. burettes which were of regular 50 cc. length, but were correspondingly smaller in internal diameter, and were graduated to 0.05 cc.⁵ These burettes were calibrated by the Bureau of Standards for 20°C., and that temperature was maintained as nearly as possible.

Analytical Standards.—Standard solutions of ammonia were carefully prepared from ammonium hydroxide and from ammonium sulfate. The former were prepared from concentrated c. p. ammonium hydroxide and neutral⁶ distilled water, and the

² Mitscherlich, E. A., and Herz, P., *Landw. Jahrb.*, 1909, xxxviii, 279.

³ Mitscherlich, E. A., and Meeres, E., *Landw. Jahrb.*, 1910, xxxix, 345.

⁴ We have subsequently found that stock distilled water redistilled over acid permanganate is sufficiently pure for the preparation of standard solutions.

⁵ These were obtained from Emil Greiner and Company, New York.

⁶ The term "neutral water" as used in this paper refers to water neutral to methyl red.

exact strength determined by a series of titrations against the titrimetric standards. The ammonium sulfate standards were prepared from ammonium sulfate, repurified according to the directions of Folin.

Nessler Reagent.—This reagent was prepared according to the directions of the Standard Methods of the American Public Health Association.⁷

Nessler-Winkler Reagent.—This reagent was prepared according to the original direction of Winkler⁸ and used according to Folin and Farmer,⁹ who made the observation that if the reagent is diluted just before use (5 cc. to 25 cc.) larger amounts of ammonia may be Nesslerized without precipitation.

Colorimeter.—A study of the Krüss polarization, and Schreiner, Wolff, and Duboscq colorimeters led to the adoption of the last named as being the most suitable for colorimetric work. The instrument used was of the standard French pattern.

Probable Error of Nesslerization.

In Nesslerization the error lies principally in the difference in the amount of color produced by the action of the reagent on the ammonia and in matching the unknown against the standard.

⁷ Methods of water analysis of the American Public Health Association, Standard methods for the examination of water and sewage, Boston, 3rd edition, 1917, 16. 50 gm. of potassium iodide in a minimum quantity of cold water were treated with saturated solution of mercuric iodide until a slight precipitate persists permanently. Add 400 cc. of 50 per cent potassium hydroxide, clarified by sedimentation, and dilute to 1 liter, allow to settle, and decant.

⁸ Winkler, L. W., *Chem. Z.*, 1899, xxiii, 541. Hawk, P. B., Practical physiological chemistry, Philadelphia, 6th edition, 1918, 517.

"Mercuric iodide.....	10 gm.
Potassium ".....	5 "
Sodium hydroxide.....	20 "
Water.....	100 cc.

The mercuric iodide is rubbed up in a small mortar with water, worked into a flask, and the potassium iodide added. The sodium hydroxide is dissolved in the remaining water, and the cooled solution is added to the above solution. After settling and decanting, the solution is kept in a dark bottle."

⁹ Folin, O., and Farmer, C. J., *J. Biol. Chem.*, 1912, xi, 496.

The former error can be reduced to a minimum by observing all possible precautions to keep conditions uniform, such as the amount of reagent, temperature, time of standing before comparison, etc.; while the latter error may be decreased by increasing the number of readings. In all colorimetric work reported in this paper, six readings were made on each unknown and its standards. The error arising from matching of unequal column heights in the colorimeter was eliminated by preparing the "standard" and "unknown" of practically equal concentrations.

The standard Nessler reagent was retained for use with amounts of nitrogen of 0.5 mg. per 100 cc.¹⁰ or less, since it is more sensitive, and in the presence of small amounts of nitrogen more stable than is the modification of Winkler.¹¹

The Nessler-Winkler reagent was used according to the directions of Folin and Farmer.

By using these reagents with the above amounts of nitrogen and employing only redistilled water, there was not the slightest tendency towards the formation of cloudiness. The colors remained perfectly clear and manifested no tendency to precipitate even after several hours. The use of ordinary distilled water, freed from ammonia by bromine and caustic soda, for diluting the reagent and making the Nesslerized solution to the mark, as has been recommended by Folin and Denis,¹² did not prove satisfactory, as there was some tendency for cloudiness to form on the addition of the reagent.

For amounts of ammonia nitrogen of 0.5 mg. and less, using the standard Nessler reagent, the procedure was as follows: The

¹⁰ The expressions "mg. N" and "mg. N per 100 cc." used in this paper in connection with Nesslerization refer to mg. of nitrogen contained in the colorimeter solution; *i.e.*, the solution after the addition of the Nessler reagent and dilution to the mark.

¹¹ This is probably due to the difference in the proportions of the mercuric salts and the potassium iodide in the two reagents. The sensitiveness increases with addition of mercuric salts and decreases by the addition of potassium iodide (see Olsen, J. C., *Quantitative chemical analysis*, New York, 5th edition, 1916, 412). Folin and Denis (Folin, O., and Denis, W., *J. Biol. Chem.*, 1916, xxvi, 479) point out, however, that for satisfactory results with their modified reagent, it should contain more potassium iodide than does the standard Nessler's reagent.

¹² Folin, O., and Denis, W., *J. Biol. Chem.*, 1912, xi, 534.

desired amounts of ammonia were measured into 100 cc. graduated flasks from the ammonium hydroxide or ammonium sulfate standards by means of burettes. These solutions were then diluted to approximately 90 cc. with ammonia-free water, 2 cc. of Nessler's reagent were added, and the solutions were made to the mark. After 15 minutes, portions of the solutions were transferred to the colorimeter cylinders, and the colors compared, as mentioned above. The standard was set at 40 mm. and three of the six readings were made after adjusting the unknown from above, and three after adjusting from below.

For amounts of nitrogen equal to 0.5 mg. or more per 100 cc. requiring the Nessler-Winkler reagent, the procedure is the same except that the solutions are made to 70 cc. in the flasks, 25 cc. of the diluted reagent added; they are then made to the mark, and the colorimetric comparisons made against a 20 mm. standard 30 minutes after adding the reagent. Six readings were made as described above.

The desired amounts of ammonia nitrogen were obtained by using the following amounts of dilute solutions:

N ₂ mg.	Solution. cc.	Normality.
0.10	10.0	N/1,400
0.50	50.0	N/1,400
1.00	10.0	N/140

For each amount of nitrogen, ten solutions (also ten standards¹³) were Nesslerized. Although the probable error of a method should be obtained by employing the results from a great many determinations using the procedure involved, the *order of magnitude* of the error of the procedure can be shown by using ten typical determinations of the procedure studied.

The probable error, r , of each individual observation is calculated with the aid of the formula

$$r = \pm 0.6745 \sqrt{\frac{\sum \Delta^2}{n-1}}$$

in which Δ indicates the deviation of each value from the mean, and n the number of observations. The results are shown in Table I.

¹³ The ammonium sulfate solutions were taken as "standards," the hydroxide solutions as "unknowns."

The results show that the probable error increases with increasing amounts of nitrogen. This must unavoidably be the case since with the larger amounts of nitrogen the colors produced are intense, a low column height (≈ 20 mm.) must be used in the colorimeter, and very slight differences in readings result in marked differences in the value found for mg. of nitrogen.

Computations were next made to ascertain to what extent the errors in the colorimetric procedure as used lay in the readings themselves and to what extent in the color produced by the reagent.

TABLE I.
Probable Error of Nesslerization.

Determination No.	Nitrogen taken.		
	mg. 0.10	mg. 0.50	mg. 1.00
	Found.		
1	0.106	0.468	0.972
2	0.098	0.516	0.996
3	0.102	0.511	1.014
4	0.102	0.497	1.013
5	0.103	0.508	1.004
6	0.102	0.489	0.995
7	0.104	0.507	1.008
8	0.105	0.476	0.962
9	0.108	0.504	0.995
10	0.106	0.487	1.002
Average.....	0.103	0.496	0.996
<i>r</i>	± 0.0019	± 0.0107	± 0.0114
<i>r</i> expressed as per cent.....	1.8	2.1	1.1

As stated above, each colorimetric determination is the average of six readings, and of course possesses an error, that of reading the colorimeter. That is, if we designate the value obtained by the colorimetric determination by a and its error by e the correct value is equal to $a \pm e$. In a series of determinations, we designate these values by $a_1 \pm e_1, a_2 \pm e_2, a_3 \pm e_3, \dots, a_n \pm e_n$. Where the values of a_1, a_2, a_3 are obtained by averaging a number of readings as was done in this case, the values of e_1, e_2, e_3 , *i.e.* the probable error R_1, R_2, R_3 of the average, may be computed with the aid of the formula

$$R = \pm 0.6745 \sqrt{\frac{\sum \Delta^2}{n(n-1)}}$$

The values of R_1 to R_5 (e_1 to e_5) were computed for a_1 to a_5 of the determinations of 1 mg. portions, reported in Table I. The results appear in Table II.

Since the values obtained for R_1 to R_5 are in every case less than the value ± 0.0114 obtained for the probable error of a set of determinations, it follows that the color produced by the same amount of nitrogen is not perfectly concordant in a series of determinations.

The error in the colorimetric method for nitrogen then increases with increasing amounts of nitrogen, and is due in part to error in

TABLE II.

Probable Error of Arithmetical Mean of Colorimeter Readings on the Same Solution.

Reading No.	Determination No.				
	1	2	3	4	5
1	0.982	1.006	1.006	1.001	1.011
2	0.965	0.996	1.015	1.021	1.011
3	0.961	0.988	1.011	1.015	1.006
4	0.982	1.001	1.025	1.025	0.996
5	0.961	0.992	1.011	1.001	1.006
6	0.978	0.992	1.015	1.015	0.996

a_1 0.972, a_2 0.996, a_3 1.014, a_4 1.013, a_5 1.004.

$R_1 = \pm 0.0028$, $R_2 = \pm 0.0018$, $R_3 = \pm 0.0016$, $R_4 = \pm 0.0028$, $R_5 = \pm 0.0019$.

measurement, and in part to differences in the amounts of color produced by the reagent under the conditions of the determinations.

The Probable Error of Titration.

In order to avoid all error due to the solubility of the glassware commonly employed as titrimetric flasks, well seasoned Pyrex glass Erlenmeyer (300 cc.) flasks were used in determining the probable error of titration.

Standard ammonium hydroxide was run into the titration flasks from a burette, 25 cc. of 0.02 N acid were added, then sufficient neutral water was added to bring the volume to 100 cc., the con-

tents were boiled to expel carbon dioxide, and after cooling to 10–15° the titration was completed, using 0.02 N alkali. The error reported here includes the error of the burettes, but since this is less than that tolerated by the Bureau of Standards, the errors reported in Table III are essentially attributable to the titration alone.

TABLE III.
Probable Error of Ammonia Determination by Titration.

Nitrogen taken.			
<i>mg.</i> 0.100	<i>mg.</i> 0.500	<i>mg.</i> 1.00	
Found.			
0.101	0.502	1.001	
0.098	0.505	1.002	
0.093	0.505	0.995	
0.098	0.505	1.001	
0.093	0.510	0.992	
0.099	0.508	1.001	
0.093	0.499	0.992	
0.101	0.508	1.005	
0.098	0.502	1.005	
0.093	0.502	1.006	
Average.....	0.097	0.505	1.000
<i>r</i>	±0.0022	±0.0022	±0.0035
<i>r</i> expressed as per cent.....	2.06	0.38	0.35

The results of the two methods of ammonia determinations as summarized in Table IV show some interesting differences.

TABLE IV.

Nesslerization.			Titration.	
N ₂ taken.	Probable error.	Error.	Probable error.	Error.
<i>mg.</i>	<i>mg.</i>	<i>per cent</i>	<i>mg.</i>	<i>per cent</i>
0.10	±0.0019	1.80	±0.0022	2.06
0.50	±0.0107	2.10	±0.0022	0.38
1.00	±0.0114	1.10	±0.0035	0.35

The probable error of Nesslerization is variable and tends to increase with increasing amounts of ammonia while that of

titration remains practically constant. For quantities of nitrogen above 0.50 mg. portions, titration must be considered more accurate than Nesslerization. With considerably less than 0.50 mg. portions of ammonia nitrogen, Nesslerization is slightly more accurate than titration.

The Probable Error of Distillation and Titration.

It sometimes happens that the ammonia in an unknown may be determined directly by Nesslerization, whereas in the case of the titration procedure, the ammonia must always be transferred by distillation (or aeration) to a measured amount of standard acid. Indeed Folin and Denis,¹⁴ and Folin and Bell¹⁵ have recently proposed a series of very convenient methods in which the nitrogen is determined directly by Nesslerization. Thus the question arises as to the error of titration plus the error of distillation. Accordingly the following series of determinations was carried out.

The distilling apparatus used in estimating the probable error of distillation and titration has been previously described.¹⁶ This apparatus is of Pyrex glass with the exception of one close rubber connection which was found not to vitiate the results when working with very small amounts of nitrogen. While this type of apparatus is not recommended for general analytical work, it has been found excellent for the most careful work where small differences must be determined. However, by using the devices described elsewhere,¹⁷ together with good block tin condensers, and the modified Benedict procedure of distillation¹⁸ very accurate results can be obtained with small amounts of nitrogen. The results obtained on 1 mg. of nitrogen are reported in Table V.

The probable error of distillation and titration is of the same order of magnitude as the probable error of titration alone. In other words the error of titration and distillation on a 1 mg. portion

¹⁴ Folin, O., and Denis, W., *J. Biol. Chem.*, 1916, xxvi, 473, 491, 497, 501, 505.

¹⁵ Folin, O., and Bell, R. D., *J. Biol. Chem.*, 1917, xxix, 329.

¹⁶ Allen, E. R., and Davisson, B. S., *Ann. Missouri Bot. Gardens*, 1919, vi, 45.

¹⁷ Davisson, B. S., *J. Ind. and Eng. Chem.*, 1919, xi, 465.

¹⁸ Allen, E. R., *Ann. Missouri Bot. Gardens*, 1919, vi, 23.

is less than that accompanying direct Nesslerization of an equal amount.

Although no data are included here for larger amounts of nitrogen, the probable error remains almost constant in absolute value and decreases in percentage with larger amounts of nitrogen. Considerable data on more complicated apparatus and with larger amounts of ammonia nitrogen showed but little greater error.¹⁹

TABLE V.
Probable Error of Distillation and Titration.

Nitrogen taken.	
	mg
	1.00
	Found.
	1.005
	0.996
	1.010
	0.998
	1.013
	1.002
	0.996
	1.007
	1.005
	1.005
Average.....	1.0037
<i>t</i>	±0.0038

Preparation, Preservation, and Use of 0.02 N Solutions.

Since more precaution must be taken in the use of 0.02 N solutions than is usually observed in volumetric analysis, it seems worth while to record at this point the procedures which, after extended trial, have proved satisfactory.

As an acidimetric standard we have found sodium carbonate satisfactory from the standpoint of convenience and accuracy. It has the advantage that the standardization is carried out under conditions practically the same as are encountered in the regular work.

¹⁹ Allen, E. R., *J. Ind. and Eng. Chem.*, 1915, vii, 521. Davisson, B. S., Allen, E. R., and Stubblefield, B. M., *ibid.*, 1916, viii, 896. Davisson, B. S., *ibid.*, 1918, x, 600; 1919, xi, 465.

The sodium carbonate is prepared from pure sodium bicarbonate by heating to 270–300° in platinum until constant weight is obtained. The bicarbonate is easily prepared in a high degree of purity, either by recrystallizing of a high grade product,²⁰ or by carbonating a filtered concentrated solution of normal carbonate.

It has been our practice never to prepare solutions *exactly* 0.02 N. The volumetric adjustment of large volumes of solutions is not entirely trustworthy unless the final solution is restandardized. Where logarithmic computations are used nothing is to be gained by having the solutions of an exact fraction of normality unless perhaps when they are used for a variety of purposes. Moreover, in the process of standardization no attempt is made to weigh out an exact amount of a molar weight of sodium carbonate, since such a procedure is inconvenient and, because of the prolonged exposure of the powdered material to the air, is likely to be inaccurate.

20 or 25 cc. portions of approximately 0.02 N acid are titrated each time. The sodium carbonate equivalent to such quantities of solutions is a rather small amount to weigh with extreme accuracy. This difficulty is, however, readily avoided by the method of aliquoting which has been recommended by Eastlack.²¹ The strength of the acid is expressed as its *nitrogen titer*; *i.e.*, its *nitrogen equivalent in gm. (or mg.) per cc.* The computation is easily made with the aid of logarithms.

It has been our practice to prepare 8 to 10 liter portions of solutions at one time. The reservoir bottles are provided with soda-lime guard tubes and the solutions are supplied to the burettes preferably through siphon tubes of Pyrex glass. The acid solution does not change strength appreciably on standing. In Table VI are given the results of change in concentration of a solution of approximately 0.02 N H₂SO₄. The original volume was 8 liters.

The sodium carbonate was in all cases prepared from Kahlbaum's bicarbonate "Zur Analyse." In Standardization I the bicarbonate was recrystallized, while in the subsequent standardizations this step was omitted. The variations in the first four determinations are insignificant. The higher value reported in

²⁰ Olsen, J. C., Text-book of quantitative chemical analysis, New York, 5th edition, 1916, 259.

²¹ Eastlack, H. E., *J. Am. Chem. Soc.*, 1918, xl, 620.

the last standardization may have been due to the fact that when the standardization was made, less than 1 liter remained in the bottle, and the walls of the bottle were covered with water which had vaporized and condensed.²² The maximum variation, however, between the lowest and highest value in the above standardizations amounts to only 0.0018 mg. of nitrogen per 1 cc. or 0.045 mg. per 25 cc. of acid, an error therefore of less than 1 per cent, and which may be disregarded except in the most exact work. Another large bottle of acid, which had been in use for a little over 11 months, showed a nitrogen titer of 0.2835 mg. at the beginning and 0.2850 at the end of this period.

The question of the deterioration of ± 0.02 N alkali solution was also studied. In Table VII are given the results of the determinations at different intervals.

TABLE VI.
Standardizations of Approximately 0.02 N H₂SO₄.

Standardization No.	Date.	Nitrogen titer.
I	Nov. 19, 1917	0.2825
II	" 13, "	0.2827
III	Dec. 17, "	0.2833
IV	Jan. 23, 1918	0.2833
V	Mar. 26, "	0.2843

From this it is seen that the change in strength of the alkali solution in 1 month is quite appreciable. It has become our practice to check the alkali solution every week. No attempt has been made to prepare or keep the alkali exactly equivalent to the acid since the cc. of alkali obtained in any titration is readily converted into cc. of alkali exactly equivalent to the acid with the aid of the equation.

$$\log c = \log A - \log \frac{\text{cc. of alkali}}{\text{cc. of acid}} \left(\text{or } + \log \frac{\text{cc. of acid}}{\text{cc. of alkali}} \right)$$

where c = cc. of alkali of exactly the same strength as the acid and A = the observed cc. of alkali. The ratio $\left(\frac{\text{cc. of alkali}}{\text{cc. of acid}} \right)$ is, of course, determined in previous titrations.

²² It has subsequently been found that a layer of white paraffin oil on the surfaces of the solutions prevents loss from evaporation.

In the use of 0.02 N solutions certain precautions are naturally necessary which may be disregarded in the more concentrated solutions. We have found that neglecting any of the following measures introduces an appreciable error.

1. The volume of solution in the titrating flasks should be kept small and constant (*i.e.* within 100 to 125 cc.), and should be well cooled and free from carbon dioxide. This procedure reduces the error from the hydrolysis of the indicator salt to a small and constant magnitude, and insures a sharp and certain end-point.

2. An approximately constant amount of standard acid should be used in each titration in order to avoid any "salt effect" on the indicator. Thus, if the ratio between the acid and the alkali is established on 25 cc. portions and 50 cc. of acid are used in a determination, a slight error is introduced.

TABLE VII.

Change in Strength of \pm 0.02 N Alkali.

Determination No.	Date.	Alkali equivalent to 25 cc. of acid.
I	Nov. 9, 1917	25.72
II	Dec. 14, "	25.55
III	Jan. 16, 1918	25.47
IV	Feb. 14, "	25.34
V	Mar. 20, "	25.16

3. Standard solutions must be properly prepared and their strength determined in the dilution in which they are finally used.

4. Solutions which have stood 12 hours or more in the burettes must be discarded.

5. The titration flasks must be of practically insoluble glass. Pyrex glass is the only material (except transparent quartz) which we have found to be entirely satisfactory.

DISCUSSION.

From the results reported above, which represent it is believed a fair measure of the relative accuracies of the titrimetric and colorimetric methods for determining ammonia, it seems that the latter are slightly more accurate. Both types of determinations have been made, it is true, under conditions more nearly ideal than

one can attain in general practice, yet the conditions described for accurate titrations may be more nearly attained than can those for satisfactory Nesslerization. Titrimetric procedures have the added advantage over the colorimetric in that they are applicable to a wide range of nitrogen values, and hence by a regulation of the size of the sample the error due to aliquoting may be kept smaller. For example, if we have a quantity of material for analysis containing 10 gm. of nitrogen, $\frac{1}{10,000}$ of the material would be taken for the determination by the colorimetric procedure. If our readings show 1.00 mg., the value is obviously 1.00 ± 0.0114 mg., and the amount of nitrogen in the material sampled would be between the limits of 10.114 and 9.886 gm. Only the first digit to the right of the decimal would be of any significance. On the other hand, if the titrimetric method is used, $\frac{1}{2,000}$ of the material may be taken for analysis. If our determination shows a value of 5.000 mg., the true value is 5.000 ± 0.0038 mg., and our final value lies between the limits 10.008 and 9.992, in which case the first digit to the right of the decimal is significant, the second doubtful, and the third of no significance. Expressed in another way the error in the colorimetric and titrimetric procedures would be under the best conditions 0.228 and 0.015 gm. respectively.

The disadvantage of the colorimetric determination of ammonium nitrogen is that the reaction involved is imperfectly understood, and it is not surprising, therefore, that in spite of the different modifications of the Nessler reagent which have appeared, the appearance of clouds and precipitates cannot be avoided with certainty by different workers.

Aside from this point, it is our opinion that the colorimetric methods are, even under the best conditions, more subject to personal error than are volumetric or titrimetric procedures. The accurate measurement of color is a more elusive and difficult operation than is generally believed and many colorimetric procedures are quite faulty in theory.

Some of the more common sources of error will be briefly considered. One which may become quite appreciable in routine colorimetric work (but which was avoided in the determinations reported above) is that due to unequal column heights, especially if the procedure of setting the standard at a definite height and

adjusting the unknown is too rigidly followed. The fact must not be lost sight of that the ordinary equation of colorimetry

$$c_1 = c_2 \frac{h_2}{h_1}$$

is based on the incorrect assumption that the solvent has no effect on the passage of light. If this error is reduced to a negligible magnitude either by the preparation of a large number of standards or by the scrupulous filtering of all solutions, as has been recommended by Krüss and Krüss²³ for colorimetric procedures in general, then the procedure becomes distinctly time-consuming.

It is of interest to note in this connection that Dehn²⁴ in a recent paper on "Fallacies in colorimetry," after pointing out the unsoundness of many existing procedures, concludes that in Folin's method of creatinine estimation, by way of illustration, there are twelve probable sources of error. A similar array also exists in the colorimetric determination of ammonium nitrogen. These fundamental errors of colorimetry probably account for the skepticism with which many chemists are inclined to view colorimetric procedures.

In view of these points we have therefore adhered to the titrimetric procedures in our work on nitrogen methods.

While the colorimetric procedures for the determination of nitrogen have been of great service because of their brevity, it should be recognized that except when dealing with amounts of nitrogen less than a few tenths mg., titrimetric methods are capable of greater accuracy and should be chosen where exact results are required.

²³ Krüss, G., and Krüss, H., *Kolorimetrie und quantitative Spektralanalyse in ihrer Anwendung in der Chemie*, Hamburg, 1909, 31.

²⁴ Dehn, W. H., *J. Am. Chem. Soc.*, 1917, xxxix, 1392, 1399.



A STUDY OF CREATINURIA IN INFANTS.

I. RELATION OF CREATINURIA TO ACIDOSIS. THE ELIMINATION OF INGESTED CREATINE AND CREATININE.

BY JAMES L. GAMBLE AND SAMUEL GOLDSCHMIDT.

(From the Laboratory of the Department of Pediatrics, and the Hunterian Laboratory of Experimental Pathology, Johns Hopkins University, Baltimore.)

(Received for publication, August 2, 1919.)

Creatine apparently never appears in the urine of a normal adult male in appreciable amounts. Normal women¹ excrete creatine periodically, while infants and children² exhibit a creatinuria regularly on normal diets. Creatine metabolism must, therefore, be studied in both sexes, and at different stages of growth, if a complete set of facts regarding the processes concerned is to be obtained. We have undertaken to put to experimental test in the male infant certain factors supposed to bear relation to creatinuria. We have also made measurements of the elimination of ingested creatine and creatinine by infants, there being no quantitative data at hand on this point at this age.

Methods.

The subjects used for the experiments described in this and the succeeding paper were infants obtained from a well conducted home for foundlings. One of them, Subject G, was a normal infant. The others failed to come up to the specifications for normal infants only in the respect that they were more or less underweight. There was in no instance a history of recent nutritional disturbance, or, during the experimental periods, symptoms

¹ Krause, R. A., *Quart. J. Exp. Physiol.*, 1911, iv, 293. Rose, M. S., *J. Biol. Chem.*, 1917, xxxii, 1.

² Rose, W. C., *J. Biol. Chem.*, 1911-12, x, 265. Folin, O., and Denis, W., *ibid.*, 1912, xi, 253.

of malnutrition. They all made moderate or rapid gains in weight on the experimental diets. The diet was in all cases cow's milk, the various modifications of which, as regards the protein, butter fat, and lactose content, are indicated in Tables I and II. The quantity of food given was carefully measured and all of it was taken. There was always a foreperiod of several days on the experimental diet before the collection of urine specimens was begun.

The urine collection periods were of 2 or more days duration. The infant during this time was immobilized by means of a comfortably arranged metabolism frame. The urine was preserved with 5 per cent thymol in chloroform. The bottle receiving the urine was stoppered and shaken every 4 hours to insure thorough disinfection, and at the end of 12 hours was replaced by a second bottle and put in an ice box. The regularly close agreement of the day to day figures indicates the quantitative collections obtained.

Creatinine and creatine were determined by the methods of Folin.³ Conversion of creatine was obtained by autoclaving the urine samples, 5 to 10 cc., at 130° for 18 to 20 minutes with 1 cc. of *N* hydrochloric acid. The acid was neutralized by adding an equivalent of 10 per cent sodium hydroxide before developing the color. Total nitrogen in milk and urine was determined by the Kjeldahl method. The factors of acid excretion in the urine, hydrogen ion concentration, titratable acidity, and ammonia, were measured as directed by Palmer and Henderson.⁴

Relation of Acidosis to Creatinuria.

One gathers from the literature the impression that acidosis stands accepted as a cause of creatinuria, or, at least, as a factor in its production. It is our belief that the presence of an actual acidosis has been in most instances only a matter of inference, and, furthermore, that in conditions where acidosis and creatinuria undoubtedly do occur together evidence of a causal relationship is lacking.

³ Folin, O., *J. Biol. Chem.*, 1914, xvii, 469.

⁴ Palmer, W. W., and Henderson, L. J., *Arch. Int. Med.*, 1913, xii, 153.

Krause and Cramer,⁵ in 1910, pointed out that creatinuria occurs in all conditions which lead to an acidosis. They cited chiefly the creatinuria of starvation and of diabetes. At that time, however, the fallacy of regularly inferring an acidosis from the presence in the urine of ketone acids was prevalent. Since we know now that production of ketone acids is only occasionally of such degree as to cause an acidosis it is obviously incorrect to regard the occurrence together of ketonuria and creatinuria as proof of the relation of the latter to acidosis.

Underhill⁶ has published results of experiments with rabbits, designed to show a relation between creatinuria and diets which produce an acid urine. An acid urine was produced by giving the rabbits a grain diet composed of corn and oats. On this diet, creatine was regularly found in the urine. When carrots were given, instead of the grain diet, creatine was found in the urine in greatly diminished quantity, or was absent. Underhill considered these results as proof of a relationship between creatinuria and acidosis. The presence of acidosis "was considered indicated when the urine of the rabbit became strongly acid, as shown by determination of the hydrogen ion concentration. . . . In the sense of the term acidosis as used here, that is, a condition of alkali depletion, the assumption given above is undoubtedly correct since ordinarily the rabbit secretes urine which is strongly alkaline." Since rabbits cannot provide the base ammonia in compensation for an unusual acid production, it is probable, though not definitely proven by the acid urine, that the rabbits Underhill experimented with did develop an acidosis.

From the well established facts in regard to the process of acid excretion in man, it is absolutely incorrect to assume a depletion of fixed alkali from an unusually acid urine. The neutrality mechanism in man is remarkably extensible and is capable of neutralizing and conveying into the urine unusually large amounts of acid without disturbance of the acid-base equilibrium within the body. The gross adjustment for an unusual acid production is an increase in production of ammonia. The fine adjustment, by means of which the reaction of the blood is maintained at the

⁵ Krause, R. A., and Cramer, W., *J. Physiol.*, 1910, xl, p. lxi.

⁶ Underhill, F. P., *J. Biol. Chem.*, 1916, xxvii, 127, 141.

TABLE I.
Effect of Ingested Alkali and Acid upon Output of Urinary Creatine.

Experiment No.	Date.	Protein per day.	Voi- ume.	Total N.	pH	Urine						Pre- formed creat- inine.	Creat- ine as creat- inine.	Remarks	
						Titra- table acid 0.1%.	NH ₃ 0.1%.	Total acid 0.1%.	Total creat- inine.	mg.	mg.				cc.
1 Control period.	1917														
	Mar. 17	20	500		6.4	44	125	169			78			Milk, 600 cc.	
	" 18	20	550		6.4	41	130	171			76			Barley water, 300 cc.	
	" 19	20	500		6.4	36	121	157			77			Lactose, 40 gm.	
	" 20	20	490		6.5	32	118	150			79				
Averages...	20	510	1.89		6.4	38	124	162			78	59			
Experimental period.	Mar. 21	20	500		8.0	-43	32				82			Same food + 4 gm. of NaHCO ₃ .	
	" 22	20	490		8.2	-39	40				82			Same food + 4 gm. of NaHCO ₃ .	
	" 23	20	540		8.1	-40	40				81			Same food + 4 gm. of NaHCO ₃ .	
	" 24	20	470		8.3	-40	35				84			Same food + 4 gm. of NaHCO ₃ .	
	Averages...	20	500	1.97		8.2	-41	37	-4			82	54		
2 Control period.	May 7	30	490		6.2	100	240	340			82	105		Whole milk, 900 cc.	
	" 8	30	490		6.4	90	204	294			81	94		Lactose, 20 gm.	
	Averages...	30	490	4.37		95	222	317			82	100			

Subject G, age 10 months; weight 6.5 to 7.1 kg.

Experimental period.	May 10	30	570		7.6	-100	92	191	83	109	Began NaHCO ₃ 36 hrs. before and continued through May 10. 4 gm. per day. No NaHCO ₃ given.
	" 11	30	520		7.6	-25	92	190	82	108	
	Averages...	30	545		7.6	-65	92	191	83	109	
3	May 21	12	590		6.4	36	95	116	65	51	16 per cent cream, 390 cc.
Control period.	" 22	12	500		6.4	30	91	100	60	40	Water, 730 cc.
	" 23	12	540		6.4	37	76	112	63	49	Lactose, 50 gm.
	Averages...	12	543	1.20	6.4	34	86	120	63	47	
Experimental period.	May 25	12	590		5.9	52	100	152	61	55	Administered 100 cc. of 0.1N HCl.
	" 26	12	600		5.9	60	119	179	63	53	No acid given.
	Averages...	12	595	-	5.9	56	109	165	62	54	
Subject M, age 14 months; weight 6.5 kg.											
4	May 21	7	690		6.2	30	90	120	70	60	16 per cent cream, 230 cc.
Control period.	" 22	7	640		6.2	32	94	126	72	64	Water, 900 cc.
	" 23	7	650		6.2	33	84	117	70	63	Lactose, 30 gm.
	" 24	7	620		6.2	31	92	123	68	62	
	Averages...	7	650	0.84	6.2	32	90	122	70	62	
Experimental period.	May 27	7	680	-	8.2	-32	31	-1	71	60	4 gm. of NaHCO ₃ daily; begun May 26.

normal pH is managed by excretion of the phosphates in correct relative amounts. Slight variations in acid production may be entirely compensated by variation in the relative amounts of the phosphates excreted, the ammonia factor remaining stationary. The acidity of the urine on normal diets may, for this reason, vary widely, the pH being frequently as great as when acidosis is present. It is therefore impossible to obtain from the pH of the urine a dependable indication of the presence of an acidosis.

It is equally incorrect to assume that diets containing an unusually large amount of acid-producing elements, or which lead to the production of abnormal acids, will necessarily cause an acidosis. Acidosis cannot safely be considered indicated unless a depletion of the fixed alkali of the blood has been demonstrated. Denis and Minot⁷ have been able to obtain with women subjects an excretion of creatine by giving diets unusually high in protein; which necessarily contain a large quantity of acid-forming elements. They have found that the addition of sodium bicarbonate to this diet produces no appreciable effect on the creatinuria. This result shows very clearly that a wide variation in the acid-base value of a diet may bear no relation to creatine excretion.

We have thought it worth while to illustrate this point further by adding acid or base to the food of infants. The results of these experiments are tabulated in Table I. We present the results of a single experiment in which 100 cc. of 0.1 N hydrochloric acid were given to an infant in its food, in divided amounts, during the course of 24 hours. There is a well marked effect on the factors concerned in acid excretion during the day the acid was given, and also on the day following. The value for creatine excretion remains the same as during the control period. We gave sodium bicarbonate freely in several instances, but did not find a change in the quantities of creatine eliminated.

We have been able to find a record of but one set of experiments in which creatine was measured in the presence of a demonstrated acidosis. Sawyer, Stevens, and Baumann,⁸ using as subjects male children, were able to produce quite regularly a depletion of the fixed alkali of the blood by giving a high fat and low carbo-

⁷ Denis, W., and Minot, A. S., *J. Biol. Chem.*, 1919, xxxvii, 245.

⁸ Sawyer, M., Stevens, F. A., and Baumann, L., *Am. J. Dis. Child.*, 1918, xv, 1.

hydrate diet. They found in all their experiments that during the period of acidosis there was a well marked increase in the excretion of creatine. They were also usually able to obtain a lowering of the bicarbonate of the blood by giving a low calorie diet, with nearly always an increase in creatine excretion. They found, however, in three instances an increase in creatine excretion on the low calorie diet without a reduction of blood bicarbonate. Their results suggest a relationship of acidosis to creatinuria. Such an inference cannot, however, be drawn with certainty because of the wide variation in the diet of factors other than those related to acid production. The authors themselves express their belief that the creatinuria was not due to the acidosis *per se*. We would suggest that the increase in creatine excretion may have been due to an abnormal protein metabolism, caused, in one case, by an inadequate intake of protein and, in the other, by the absence of the protein-sparing effect of carbohydrate. As compared with its value on the normal control diet, the nitrogen in the urine was relatively high during the low calorie periods and absolutely high during the high fat intake periods.

We would say in conclusion that variations in the acid-base value of normal diets cannot possibly bear relation to creatinuria in man for the reason that they are never of sufficient magnitude to disturb the normal acid-base equilibrium within the body. As regards the relation to creatine excretion of acidosis produced by abnormal diets, we do not find in the literature satisfactory evidence indicating acidosis *per se* as a factor concerned in causing or increasing creatinuria.

The Elimination of Ingested Creatine and Creatinine in Infants.

It is well established by the original investigations of Folin⁹ and of Klercker¹⁰ that large amounts of creatine may be ingested by adult men with a failure of creatinuria. Moreover, doses of creatine, which fail to produce creatinuria on a low protein diet, cause a creatine output on a high protein intake. Only a small percentage of the ingested creatine appears in the urine

⁹ Folin, O., Festschrift für Olof Hammersten, Upsala, 1906.

¹⁰ af Klercker, K. O., *Beitr. Chem. Physiol. u. Path.*, 1906, viii, 59; *Biochem. Z.*, 1907, iii, 45.

in any case, and for the most part, the ingested nitrogen remains unaccounted for in the urine.

Mellanby¹¹ suggested that the results given above may be due to the action of intestinal bacteria in destroying the ingested creatine. In fact, Twort and Mellanby¹² have isolated a bacillus from the human feces which destroys creatine. Hence, according to these authors, in creatine-feeding experiments this factor must be taken into account. While the validity of this observation cannot be denied, it must be pointed out that according to more recent investigations, in which the creatine is introduced parenterally, the original contention of Folin and of Klercker is confirmed. Lyman and Trimby¹³ find that 76 per cent of the creatine nitrogen, injected subcutaneously into man, remains unaccounted for in the urine. Meyers and Fine,¹⁴ and Rose and Dimmitt,¹⁵ after ingestion, as well as Lyman and Trimby¹³ after injection of creatine, believe that they found an increased output of urinary creatinine which they attribute to converted creatine. In this finding they stand in opposition to the results of Folin⁹ and of Klercker.¹⁰

When creatinine is fed to adult men, observers are agreed that greater amounts are eliminated than is the case with creatine. Folin⁹ and Rose and Dimmitt¹⁵ report recovery of 80 per cent of the creatinine ingested.

Krause¹⁶ investigated the fate of exogenous creatine in two girls (aged 6 and 11 years), and two boys (aged 5 and 8 years); the older of each sex was not excreting creatine. He finds that, in children, relatively small amounts of creatine (0.3 to 0.35 gm.) lead to an increased creatinuria if one already existed, or to a creatinuria where there was none previously. The author concludes that in children the power of "assimilating" creatine, if measured in absolute amounts, is less developed than in adults. Further, this is true even when the power of "assimilating" creatine is calculated per kilo of body weight; and the younger the child the less ingested creatine can it retain.

¹¹ Mellanby, E., *J. Physiol.*, 1907-08, xxxvi, 447.

¹² Twort, F. W., and Mellanby, E., *J. Physiol.*, 1912, xliv, 43.

¹³ Lyman, J. F., and Trimby, J. C., *J. Biol. Chem.*, 1917, xxix, 1.

¹⁴ Meyers, V. C., and Fine, M. S., *J. Biol. Chem.*, 1915, xxi, 377.

¹⁵ Rose, W. C., and Dimmitt, F. W., *J. Biol. Chem.*, 1916, xxvi, 345.

¹⁶ Krause, R. A., *Quart. J. Exp. Physiol.*, 1914, vii, 87.

The investigation to be presented herewith was instituted in order to test the effect of ingested creatine upon the creatinuria of infants, not only because of the interest attached to the data thus obtained, but also since they are necessary in connection with results presented in the paper which follows.

Both subjects used were of the male sex and creatine was a constant urinary constituent. The creatine and creatinine administered were dissolved in the total amount of milk to be fed during the day. Hence, the subject received but a small amount of creatine or creatinine at each feeding.

The creatine was a pure preparation free from creatinine and contained 1 mol of water of crystallization. The amounts noted in the protocols, however, are calculated as anhydrous. The creatinine was likewise a pure preparation isolated from urine.

EXPERIMENTAL.

In the experiments detailed in Table II, it is apparent that even on a low protein diet (Experiments 1 and 5), from 12 to 16 mg. per kilo, or an absolute amount of 88 mg., suffice to cause an increased urinary creatine. No attempt is made to determine the least amount of ingested creatine which would lead to such an increase, but indications are that it would be very small.

As regards the completeness of excretion, it will be noted that in Experiments 1, 2, and 5, on a low protein diet, 24 to 34 per cent of the ingested creatine is recovered in the urine during the first 24 hours. It must be recalled that, in these experiments, the creatine administered was mixed with the food and given throughout the day with each feeding. As a result it is found that the urine of the 2nd day still contains extra creatine. Hence, if the total extra creatine excreted in 2 days is calculated, we obtain figures of from 35 to 58 per cent.

In Experiment 3, the subject is on a high protein level. The afterperiod is considerably lengthened in order to study more completely the lag in creatine excretion. In this experiment, taking the 1 day foreperiod as the normal output, in the first 24 hours there is an extra excretion of 52 per cent of the creatine ingested. Moreover, it will be seen that the urinary creatine continues to be high for at least 3 days after the day of feeding.

TABLE II.
Effect of Ingested Creatine and Creatinine upon Urinary Creatine and Creatinine.

Experiment No.	Date.	Weight, kg.	No. of days on diet	Pro- tein per day.	Total N			Urine			Remarks.	
					gm.	mg.	mg.	Total creat- inine	Pre- formed creat- inine.	Crea- tinins creat- inine.		Crea- tine- time.
Subject G, age 10 months.												
1 Control period.	1917 May 31	7.2	18	12	1.57	136	71	65	75	Low protein { 16 per cent cream. diet } water.		
	June 1			12	—	156	71	85	99	Urine contained acetone during 3 days of experiment.		
Experimental period.	June 1			12	—	156	71	85	99	Administered in food 0.088 gm. of creatinine. Extra creatinine excreted on 1st day = 24 mg. = 27 per cent of ingested creatinine.		
	" 2			12	—	143	72	71	82	Total extra creatinine excreted in 2 days = 31 mg. = 35 per cent of ingested creatinine.		
2 Control period.	June 9	7.7	26	12	0.84	137	75	62	72	Low protein { 16 per cent cream. diet } lactose. water.		
	June 10			12	—	215	75	140	162	Administered in food 0.264 gm. of creatinine. Extra creatinine excreted on 1st day = 90 mg. = 31 per cent of ingested creatinine.		
Experimental period.	" 11			12	—	176	76	100	116	Total extra creatinine excreted in 2 days = 134 mg. = 51 per cent of ingested creatinine.		

3 Control period.	June 25	8.2	9	40	5.16	194	87	107	124	High protein { whole milk. diet Administered in food 0.264 gm. of creatine. Extra creatine excreted on 1st day = 136 mg. = 52 per cent of ingested creatine. Total extra creatine excreted in 2 days = 193 mg. = 73 per cent of ingested creatine. Total extra creatine excreted in 3 days = 229 mg. = 87 per cent of ingested creatine. Total extra creatine excreted in 4 days = 259 mg. = 98 per cent of ingested creatine. Total extra creatine excreted in 5 days = 270 mg. = 102 per cent of ingested creatine.
	June 26			40	—	317	93	224	260	
	" 27			40	—	242	86	156	181	
	" 28			40	—	233	95	138	160	
	" 29			40	—	222	89	133	154	
	" 30			40	—	204	88	116	135	
4 Control period.	June 19	8.2	2	40	5.30	218	83	135	157	High protein { skim milk. diet Administered in food 0.2 gm. of creatine. Extra creatine excreted 1st day = 101 mg. = 50 per cent of ingested creatine. Total extra creatine excreted in 2 days = 124 mg. = 62 per cent of ingested creatine.
	" 20			40	—	216	84	132	153	
	June 21			40	—	314	185	129	150	
	" 22			40	—	234	107	127	147	
Experimental period.										

TABLE II. *Continued.*

Experiment No.	Date.	Weight, <i>kg.</i>	No. of days on diet.	Protein per day.	Urine.				Remarks.	
					Total N.	Total creatinine.	Pre-formed creatinine.	Creatinine.		
Subject N., age 8 months.										
5 Control period.	1917 June 4	5.4	3	6	0.50	68	56	12	14	Low protein lactose-water.
	" 5			6		68	56	12	11	
	" 6				6		84	51	30	35
Experimental period.	" 7			6		91	53	38	44	Extra creatine excreted in 2 days = 51 mg. = 58 per cent of ingested creatine.

These increases are greater than the experimental variations from day to day. In the first 2 days 73 per cent of the ingested creatine is excreted, in 3 days 87 per cent, and in 4 days 98 per cent. The figure on the 5th day is still slightly higher than the foreperiod, so that the total excretion is 102 per cent. Allowing 10 per cent, a very liberal allowance, for a possible variation in the normal excretion, the figure for creatine on the 5th day may be considered as a return to the normal. Therefore, the average normal excretion is between 124 and 135 mg. (130 mg.). On this basis we get a total extra excretion of creatine of 235 mg., or 89 per cent of the amount ingested.

Experiment 4 presents an isolated experiment on creatinine ingestion. In a period of 2 days, 62 per cent of the ingested creatinine appears in the urine. The daily output during this time is still not down to the normal figure of the foreperiod, hence it is possible that, had the period been lengthened, more creatinine might have been excreted.

These experiments show no evidence of the conversion of ingested creatine into creatinine or *vice versa*.

DISCUSSION.

The results given above show: first, that in the infant small amounts of ingested creatine lead to an increased urinary output. Second, there is evidence that in infants the ingested creatine is nearly or completely eliminated during a period of several days. Third, from a comparison with experiments in the literature of the behavior of creatine ingested by adult men with the behavior in the infants studied by us, the following points are suggested: (a) smaller absolute amounts of ingested creatine lead to urinary excretion of creatine in infants than is the case with adult males; (b) ingested creatine is more completely excreted by the infant than by the adult male; (c) although the comparison presents greater difficulties of demonstration, there is an indication that, per kilo of body weight, smaller quantities of ingested creatine lead to excretion of creatine in infants than in adult males.

In Experiments 1 and 5 (Table II), where the lowest protein level obtains, it is found that from 12 to 16 mg. of creatine per kilo of body weight or an absolute amount of 88 mg. is sufficient

to cause an increased urinary creatine of from 35 to 58 per cent in 2 days. Under similar conditions in the adult male, Folin⁹ found it necessary to administer 6 gm. (in three portions) before excretion of creatine is obtained, and even then but 16 per cent of the amount ingested is recovered. Klercker¹⁰ took 2.06 gm. (22 mg. per kilo) of creatine on a low protein diet with failure of excretion. Plimmer, Dick, and Lieb¹⁷ are compelled to administer 2.5 gm. of creatine to an adult man, on an average protein intake, before creatinuria occurs. This amounts to 34.7 mg. per kilo of body weight.

On a high protein level (Experiment 3), the excretion in our subject is somewhat greater in an equal interval of time than on a low level of protein intake. Of the ingested creatine (264 mg. or 32 mg. per kilo of body weight), 73 per cent is eliminated in 2 days, and nearly, if not all, in an interval of 5 days. On a high protein level Folin⁹ found that ingestion of 5 gm. of creatine (in three portions) leads to the excretion of 36 to 54 per cent of the amount ingested. Klercker finds that under like conditions when 2.59 gm. are taken (28 mg. per kilo) but 30 per cent of the ingested creatine is excreted.

The results obtained by us are in accord with those obtained by Krause¹⁶ on older children, although this author did not observe the complete excretion of creatine which is indicated in our experiment.

In the normal adult (Folin,⁹ Klercker,¹⁰ and Meyers and Fine¹⁴), there is no such lag leading to a complete excretion of creatine as is observed in Experiment 3.

Powis and Raper¹⁸ found that upon feeding 206 mg. of creatine to a girl 4 years old, with amyotonia congenita, there was an increased creatine excretion for 48 hours following its administration, leading to a nearly total elimination of the ingested creatine.

Determinations of creatine tolerance for children and adults of both sexes have not been made, and from scattered observations in the literature, accurate comparisons are impossible. However, on the basis of our experiments, it seems justifiable to say that

¹⁷ Plimmer, R. H. A., Dick, M., and Lieb, C. C., *J. Physiol.*, 1909-10; xxxix, 98.

¹⁸ Powis, F., and Raper, H. S., *Biochem. J.*, 1916, x, 363.

in the infant the tolerance is much less than in the adult, and, furthermore, excretion is more complete in the infant than in the adult.

The significance and bearing of these results on recent work will be brought out in the next paper.

CONCLUSIONS.

1. Variations in the acid-base intake have no effect on the creatinuria of infants.

2. There is no satisfactory evidence that acidosis *per se* is a factor in the production of creatinuria.

3. Small amounts of ingested creatine lead to an increase of the creatinuria in infants. In a single experiment, on a high protein diet, a practically complete elimination of ingested creatine was observed.

4. There is evidence that the infant differs radically from the adult in its behavior towards ingested creatine.



A STUDY OF CREATINURIA IN INFANTS.

II. RELATION OF PROTEIN INTAKE TO URINARY CREATINE.

BY JAMES L. GAMBLE AND SAMUEL GOLDSCHMIDT.

(From the Laboratory of the Department of Pediatrics, and the Hunterian Laboratory of Experimental Pathology, Johns Hopkins University, Baltimore.)

(Received for publication, August 2, 1919.)

Effect on Creatine Excretion of Different Levels of Protein Intake Obtained by Giving Milk or Milk Dilutions.

The relation to creatinuria of various dietary factors has been suggested and investigated. Recent investigations seem to indicate quite definitely a relation of creatinuria to the size of the protein intake.¹ In as far as these observations apply to infants, investigators are confronted with the difficulty of administering a creatine-free diet. We shall present data in this paper which show that, in the infant on a milk diet, the protein intake *per se* is not entirely responsible for the increased output of creatine obtained by increasing the intake of milk.

One of us² several years ago, during a study of the nitrogenous end-products found in the urine of an infant at different levels of protein intake, noted that during the period when the least amount of protein was given there was an almost complete disappearance of creatine from the urine. As the quantity of protein in the food was increased, the amount of creatine in the urine rose steadily. The creatinine excretion preserved throughout the experiment a closely constant value. During all the experimental periods the infant received a normal caloric intake, and the nitrogen balance was positive. The size of the protein intake, as a factor concerned in determining the quantity of creatine in the urine,

¹ Denis, W., *J. Biol. Chem.*, 1917, xxx, 47. Denis, W., and Kramer, J. G., *ibid.*, 189. Denis, W., and Minot, A. S., *ibid.*, 1917, xxxi, 561.

² Talbot, F. B., and Gamble, J. L., *Am. J. Dis. Child.*, 1916, xii, 333.

seemed clearly indicated by this experiment. Folin and Denis³ had previously suggested that this effect might be obtained in children by varying the quantity of protein given. They based their assumption on the theory that the normal creatinuria of children is due to a much higher level of protein consumption in proportion to body mass than is the case with adults.

We undertook some time ago to confirm these findings by repeating the experiment with several infants. Soon after we had begun our work, Denis and Kramer¹ published the results of similarly devised experiments, using as subjects several children and one infant. They found a wide difference in the amount of creatine in the urine when the excretion on high and low protein diets was compared. They conclude, "that the amount of creatine found in the urine of children is directly dependent on the intake of protein, being high when large quantities of protein (creatinine-free) are ingested, decreasing and in some cases disappearing entirely when the child is fed a diet of an extremely low protein content." The protein constituents of the high protein diet given the children were eggs, cheese, gelatin, and milk. A mixture of whole and fat-free milk constituted the high protein food of the infant. During the low protein period, the infant received 40 per cent cream, oatmeal water, and lactose.

In the experiments on infants, to be reported in this paper, different levels of protein were obtained in quite the same way, except that for the low protein periods we used a dilution of 16 per cent cream. We therefore did not feed so small a quantity of protein as did Denis and Kramer,¹ which possibly accounts for the fact that we did not obtain in any instance a complete disappearance of creatine from the urine. A proper caloric value was obtained in the cream dilutions by the addition of lactose. The methods employed have been described in the preceding paper.

Results of Experiments.

The results of our experiments are given in Table I. They are substantially in agreement with those of Denis and Kramer.¹ A high excretion on whole milk and a low excretion on diluted cream is obtained in both instances. Dilutions of whole milk give an

³ Folin, O., and Denis, W., *J. Biol. Chem.*, 1912, xi, 253.

TABLE I.

Effect on Creatine Excretion of Increasing the Quantity of Milk Given.

Food.	Fore-period.	Date.	Urine.			Creatine Weight, as creatinine.
			Nitrogen.	Creatinine.	Weight.	
Experiment 1. Subject M, age 14 months; underweight.						
1	<i>days</i>	1917	<i>gm.</i>	<i>mg.</i>	<i>mg.</i>	<i>kg.</i>
16 per cent cream, 224 cc.						
Water, 896 cc.	5	Mar. 22		70	60	6.5
Lactose, 56 gm. ($\frac{1}{3}$ whole milk.)		" 23		72	61	
		" 24		70	63	
		" 25		68	62	
7 gm. protein.			0.84	70	62	
2						
$\frac{1}{2}$ whole milk + lactose 47 gm., 1,120 cc.	5	Apr. 2		76	75	6.6
		" 3		70	68	
		" 4		68	61	
		" 5		69	64	
18 gm. protein			2.14	71	67	
3						
Whole milk + lactose 20 gm., 1,120 cc.	2	Apr. 18		72	97	6.7
		" 19		71	93	
		" 20		76	89	
36 gm. protein.			4.56	73	91	
4						
Whole milk + lactose, continued.	14	Apr. 30		80	110	6.7
		May 1		79	107	
		" 2		81	99	
		" 3		82	120	
		" 4		74	117	
			4.62	79	111	
5						
Whole milk + lactose, continued.	22	May 8		81	125	6.8
		" 9		81	124	
			5.08	81	124	

TABLE 1—*Concluded.**Effect on Creatine Excretion of Decreasing the Quantity of Milk Given.*

Food.	Fore-period.	Date.	Urine.			Weight.
			Nitrogen.	Creatinine.	Creatine as creatinine.	
Experiment 2. Subject G, age 10 months; normal infant.						
1	<i>days</i>	<i>1917</i>	<i>gm.</i>	<i>mg.</i>	<i>mg.</i>	<i>kg.</i>
Whole milk + lactose 20 gm., 900 cc. 30 gm. protein.	13	May 11		84	109	6.8
		" 12		82	108	
			4.37	83	108	
2						
16 per cent cream, 390 cc. Water, 730 cc. ($\frac{1}{3}$ whole milk.) 12 gm. protein.	2	May 15		72	79	6.5
		" 16		71	69	
		" 17		69	53	
		" 18		61	49	
			1.86	68	63	
3						
Same + lactose, 50 gm.	8	May 21		65	51	6.9
		" 22		60	40	
		" 23		63	49	
				1.20	63	

intermediate value. It should be noted, however, that in the case of Subject M there is still a considerable excretion of creatine when the food given is cream diluted four times. We are inclined to doubt the possibility that creatine could have been made to disappear by giving still less protein.

The fact that the increase in creatine excretion takes place quite gradually, on changing from a low to a high protein intake, appears in the tables. In the case of Subject M, the increase in creatine excretion on a high protein intake is followed over a period of 3 weeks, and even then we cannot be certain that it has reached a stationary value. It will also be noted that on changing from a high to a low protein intake (Subject G) the decrease in creatine excretion, while it takes place more rapidly, nevertheless requires

a period of days to reach a fixed level. In order to indicate the relation of this time factor to our results, we have placed in the tables, in the column marked "foreperiod," the number of days the infants were on a given protein intake before the observation period was begun.

Besides the increase in creatine excretion as the level of protein intake is raised, there is also a gradual but definite increase in creatinine elimination (Subject M). Greatly lowering the protein intake produces a well marked decrease in creatinine excretion (Subject G). A relation of protein intake to creatinine excretion is not discernible in the tables of the results of Denis and Kramer's¹ experiments.

Effect on Creatine Excretion of Varying the Amount of Whey Given.

Different levels of protein intake were obtained in the experiments just described by giving whole milk, whole milk diluted, or 16 per cent cream diluted. The infants, therefore, received various amounts of cow's milk. The resultant effect on creatine excretion is evident. However, from the results of experiments described below, it appears clearly that creatine excretion in infants, fed on cow's milk, cannot be related directly to protein intake *per se*.

Although milk has been regularly and largely used as a constituent of creatine-free diets, it has long been known that milk is not creatine-free. The quantity of creatine in cow's milk has been considered so small as to bear no appreciable relation to creatine excretion. In the case of infants, however, whose sole food is milk, and who take a relatively large volume of it, it would seem that its creatine content ought to be considered.

Using the method of Wilson and Plass,⁴ we have obtained figures for preformed creatinine of \approx 1.0 mg., and for creatine of 6 to 11 mg. per 100 cc. of cow's milk. Folin's method⁵ may give results equally high. The older infants, with whom we experimented, received during the period of high protein feeding more than a liter of milk. If the value of creatine content given above is approximately correct, variation in the quantity of preformed

⁴ Wilson, D. W., and Plass, E. D., *J. Biol. Chem.*, 1917, xxix, 413.

⁵ Folin, O., *J. Biol. Chem.*, 1914, xvii, 475.

creatine in the food would be sufficient to account for the difference between the quantities of creatine in the urine, when large and small amounts of cow's milk were given. We very much doubt their correctness.

Denis and Minot⁶ have recently reported that the values obtained by Folin's method are twice too high. We submit, however, that it is extremely difficult to determine the quantity of creatine present in milk. We have, by various devices, tried to obtain a dependable color of sufficient intensity to read accurately, but have been quite unable to attain the conviction that we could measure the quantity of creatine present with even approximate accuracy. We have had no better success with the recently published method of Denis and Minot.⁶

In an experiment described in the preceding paper, it was found that creatine fed to an infant was excreted apparently quantitatively. This result greatly increased our suspicion that the preformed creatine present in cow's milk may be a large factor in the creatine excretion of infants. Having decided that we were unable to test this point directly by measuring the creatine content of milk, we undertook to obtain indirect evidence by observing the effect on creatine excretion of varying the amount of whey in the food. Creatine may reasonably be supposed to be in solution in milk. If this is true, its quantity in the infant's food will be proportional to the amount of whey present.

Results of Experiments.

The results of these experiments are given in Table II. In Experiments 1 and 2, three experimental diets were used. The infant was first given diluted cream, then undiluted whole milk, and, finally, diluted cream plus purified casein to such extent as to raise the protein value of the mixture to nearly that of undiluted milk. In Experiment 1 the excretion of creatine falls to the same low value on the diluted cream plus casein diet (Period 3) as when diluted cream alone is given (Period 1), in spite of the fact that the protein intake on the former diet is three times that when diluted cream alone is given. When the protein intake is increased by administration of skim milk (Period 2), the creatine excretion

⁶ Denis, W., and Minot, A. S., *J. Biol. Chem.*, 1919, xxxvii, 353.

TABLE II.

Effect on Creatine Excretion of Varying the Quantity of Whey in the Food.

Food.	Fore-period.	Date.	Urine.			Weight.
			Nitro-gen.	Creat-inine.	Creatine as creat-inine.	
Experiment 1. Subject G, age 10 months; normal infant.						
1	<i>days</i>	<i>1917</i>	<i>gm.</i>	<i>mg.</i>	<i>mg.</i>	<i>kg.</i>
16 per cent cream, 390 cc. Water, 730 cc. Lactose, 50 gm.	8	May 21 " 22 " 23		65 60 63	51 40 49	
12 gm. protein.			1.20	63	47	6.9
2						
Skim milk, 1,120 cc. 40 gm. protein.	6	June 19 " 20		83 84	135 132	
			5.30	84	133	8.2
3						
16 per cent cream, 280 cc. Water, 840 cc. Casein, 30 gm. Lactose, 60 gm.	5	July 6 " 7		79 83	44 48	
38 gm. protein.			3.84	81	46	8.2
Experiment 2. Subject S, age 8 months; undernourished.						
1						
16 per cent cream, 168 cc. Barley water, 672 cc. Lactose, 60 gm. ($\frac{1}{4}$ whole milk.) 5 gm. protein.	3	June 5 " 6		56 56	12 12	
			0.50	56	12	5.4
2						
Whole milk, 900 cc. 30 gm. protein.	10	June 18 " 19		56 55	59 58	
			3.78	56	58	5.5
3						
16 per cent cream, 230 cc. Ba ley water, 760 cc. Casein, 20 gm. Lactose, 45 gm. 27 gm. protein.	8	July 5 " 6		55 53	48 47	
			3.03	54	47	5.9

TABLE II—Concluded.

Food.	Fore-period.	Date.	Urine.			Weight.
			Nitrogen.	Creatinine.	Creatine as creatinine.	
Experiment 3. Subject X, age 16 months; underweight.						
1	days	1919	gm.	mg.	mg.	kg.
Whole milk, 1,180 cc.	5	Apr. 2		83	80	
		" 3		81	78	
		" 4		81	84	
Nitrogen, 5.34 gm.			4.41	82	81	5.9
2						
Water, 1,050 cc.	7	Apr. 22		81*	18	
Curd from 1,500 cc. milk.		" 23		90	22	
Dextri-maltose, 70 gm.		" 24		91	19	
Nitrogen, 4.20 gm.			2.60	88	20	
Experiment 4. Subject R, age 2 yrs.; underweight.						
1						
Whole milk, 1,120 cc.	3	Mar. 20		78	93	
		" 21		81	89	
Nitrogen, 5.61 gm.			4.40	80	91	6.8
2						
16 per cent cream, 320 cc.]	2	Apr. 9		93	105	
Whey, 800 cc.						
Lactose, 24 gm.		" 10		99	104	
Nitrogen, 2.26 gm.			1.43	96	104	7.2
3						
16 per cent cream, 320 cc.]	5	Apr. 25		91	34	
Water, 800 cc.						
Casein, 24 gm.		" 26		89	34	
Lactose, 24 gm.						
Nitrogen, 4.35 gm.			3.21	90	34	6.9
Experiment 5. Subject C, age 4 months; slightly underweight.						
1						
Breast milk, 620 cc.	1	Apr. 4		46	10	
		" 5		47	11	
		" 6		45	11	
Nitrogen, 1.01 gm.			0.42	46	11	4.5
2						
16 per cent cream, 134 cc.]	3	Apr. 19		55	51	
Whey, 536 cc.		" 20		60	40	
Lactose, 7 gm.		" 21		69	41	
Nitrogen, 1.15 gm.			0.81	61	44	4.6

* Computed from a 12 hr. specimen.

is markedly increased. In Experiment 2, with a similar experimental procedure, the same result is not obtained; the creatine excretion remains nearly as high on the diluted cream plus casein diet (Period 3), as during the whole milk period (Period 2). In Experiment 4, however, there is also found a much lower creatine excretion on a cream plus casein mixture than occurs when whole milk is fed. Although the protein intakes are not exactly the same, the difference is slight, and, furthermore, the differences in creatine output are out of proportion to the slight variation in protein.

In another experiment (No. 3), four times as much creatine is found in the urine on a whole milk diet as when curd without whey is given. The effect of diluting cream with whey is tested in Experiment 4 and it is found that somewhat more creatine is excreted than when the food is whole milk, containing more than double the amount of protein.

We obtained with a 4 months infant a breast milk period (Experiment 5) and find the excretion of creatine low. Breast milk protein is, in contrast with cow's milk protein, largely composed of whey proteins. This infant was then given a cream and whey mixture of nearly the same nitrogen value as breast milk, and containing casein and whey in approximately the same proportions as breast milk. The creatine excretion on this food is four times as great as on breast milk. This observation suggests that cow's milk may contain a great deal more creatine than breast milk. Inference from the results of this experiment is difficult, however, from the fact that the urine during the cream and whey period contains double the amount of nitrogen found when the food was breast milk, although the nitrogen intake was the same.

Creatinine excretion is increased in Experiment 1, when the food was changed from diluted cream to skim milk, and the same effect is obtained in Experiment 4, when whey was added to the cream. In both instances the higher value for creatinine excretion is maintained when the diet was changed to a protein intake composed mostly of casein, although on this diet there is, in these experiments, a marked decrease in creatine excretion. No effect on creatinine was observed in Experiment 2.

Discussion of Results.

The most obvious inference to be obtained from these results is that creatine contained in cow's milk may be a large factor in the creatinuria of infants fed on modification of cow's milk. We are altogether uninformed as to the actual value for creatine in cow's milk, and therefore admit the possibility of the presence in the whey of a precursor of creatine. One point clearly brought out is that the creatinuria of infants cannot be directly referred to the total protein value of the milk given. We do not wish to argue that the values for creatine excretion obtained by Denis and Kramer¹ in children may have been due to the milk portion of the high protein diet used. We feel, however, that the as yet undetermined value for the creatine content of milk makes somewhat uncertain the interpretation of the significance of creatinuria when milk forms part of a supposedly creatine-free diet.

The increased creatinine excretion on whole milk and on cream and whey may very well have been due to the larger amount of creatinine in the food than was the case when diluted cream was given. The fact that the creatinine excretion remained high, when the high protein intake was composed nearly altogether of casein (Experiments 1, 2, and 4), requires some other explanation. We can only suggest with diffidence that it is conceivable that an increase in endogenous metabolism may have been caused by the effect on basal metabolism of the high protein intake. The specific dynamic effect of protein has been shown to be very large in infants.⁷

Steenbock and Gross⁸ have reported an increase of creatinuria in starving pigs when they are given casein. The results of our experiments on infants are not in agreement with this finding. Such a discrepancy of result is not, however, surprising when the wide difference in experimental conditions is taken into consideration. The basis of Steenbock and Gross' experiments is a starving metabolism, whereas the subjects of our experiments received an adequate caloric intake.

¹ Howland, J., *Tr. 15th Internat. Congr. Hyg. and Demog.*, 1913, ii, pt. 2, 438. Hoobler, B. R., *Am. J. Dis. Child.*, 1915, x, 153.

⁷ Steenbock, H., and Gross, E. G., *J. Biol. Chem.*, 1918, xxxvi, 265.

SUMMARY.

We present the results of experiments which indicate that the creatine excretion of infants bears a relation to the quantity of cow's milk fed, and also results of other experiments which indicate that the quantity of whey given is more directly related to the degree of creatinuria than is the total protein value of the food.

On the assumption that preformed creatine in milk modifications is in proportion to the quantity of whey present, our results suggest that the ingestion of creatine is probably a large factor in the creatinuria of infants fed on cow's milk. The desirability of a more definite knowledge of the creatine content of cow's milk is indicated.

Note.—Since this paper was completed for publication Denis and coworkers have published creatine and creatinine determinations on human and cow's milk (*J. Biol. Chem.*, 1919, xxxviii, 453; xxxix, 47), using the method of Denis and Minot.⁶ The amounts found are smaller than those obtained by earlier methods, yet, on the basis of the above work, are sufficient to produce changes in urinary creatine upon varying the quantities of whole milk fed to infants. The suggestion above, from an isolated experiment, that cow's milk may contain more creatine than human milk, is not borne out by Denis' figures.

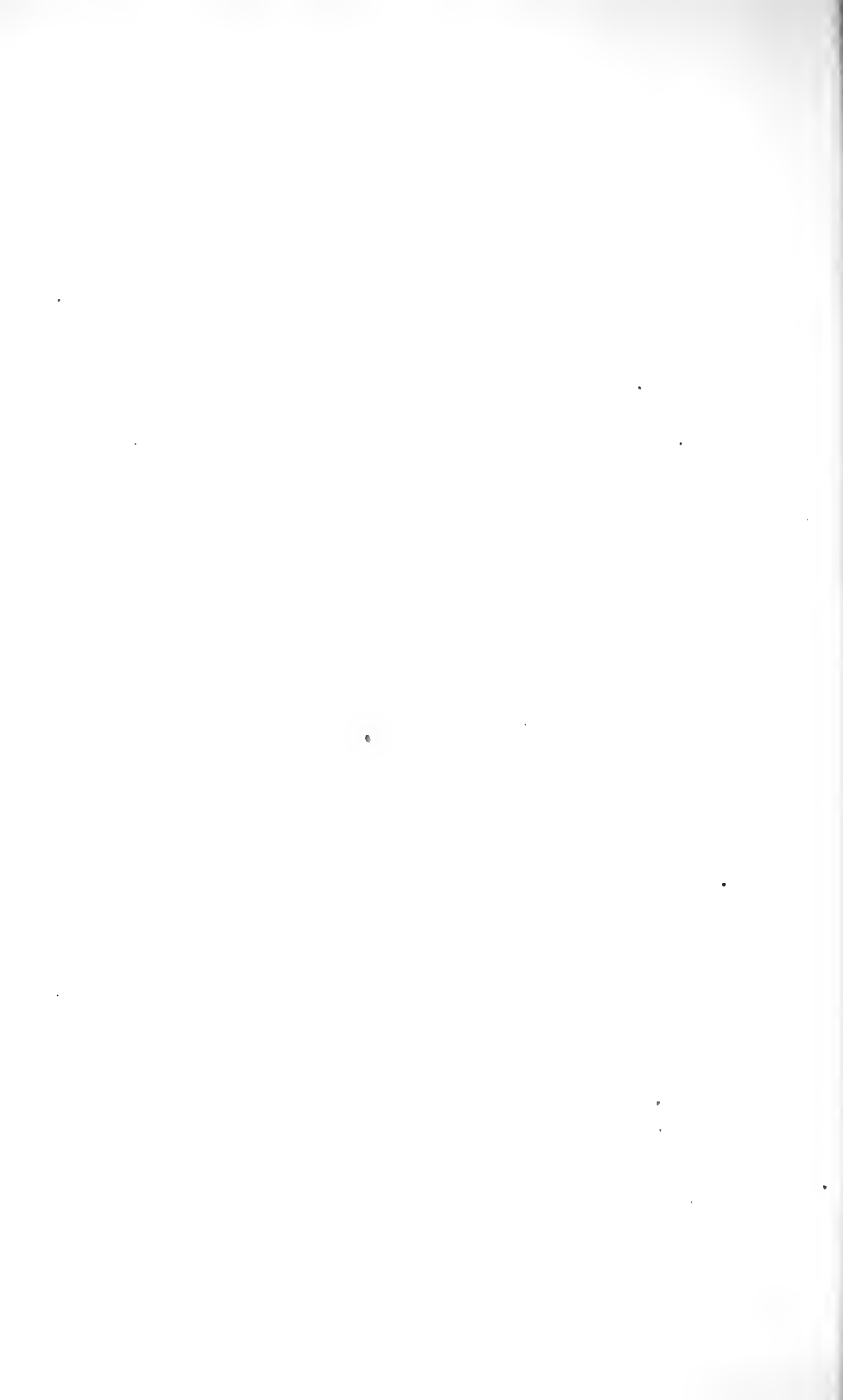

PLACENTAL FEEDING AND PURINE METABOLISM.

BY VICTOR JOHN HARDING AND ELRID G. YOUNG.

(From the Biochemical Laboratory, McGill University, Montreal.)

(Received for publication, September 12, 1919.)

In a previous paper Harding and Fort¹ made the suggestion that if the placenta played an active part in the nutrition of the fetus such a rôle might perhaps be found in its influence on the purine metabolism. This was suggested by the fact that their placental preparation proved to be unusually rich in arginine when compared with other organs of the human body, and also by the fact that Ackroyd and Hopkins² had adduced evidence to show that arginine and histidine could be regarded as the precursors of synthetic purines in the growing rat.

EXPERIMENTAL.

In order to obtain experimental evidence either for or against the supposition, it was decided to institute a series of feeding experiments in which the influence of the placenta could be contrasted with that of other proteins which might possibly serve as reserve sources of one or more amino-acids for the fetus. Placental feeding was compared with muscle feeding, and the effect on the excretion of allantoin and uric acid noted in the growing dog (not in the adult). The puppy was chosen as the experimental animal, as it gave us the opportunity to use the meat powder and placenta in moderate quantities; moreover, the quantity of food could be readily controlled, and a sufficient amount of urine was available for daily analysis. In addition, we wished to obtain evidence on the condition of creatinuria which is present in puppies and kittens according to Closson,³ and our experiments were thus

¹ Harding, V. J., and Fort, C. A., *J. Biol. Chem.*, 1918, xxxv, 29.

² Ackroyd, H., and Hopkins, F. G., *Biochem. J.*, 1916, x, 551.

³ Closson, O. E., *Am. J. Physiol.*, 1906, xvi, 252.

designed for a double purpose. Our experiments on creatinuria will be reported in a later communication. The kitten was found to be unsuited as an experimental animal. Confinement in a metabolism cage soon causes loss of appetite in the most robust animal. Even with the puppy it was found advisable to institute a "free" day every 3 or 4 days to insure a continuance of health. On the "free" day the puppy received the experimental diet but was not confined in the metabolism cage. The puppies used were usually between 3 and 4 months of age. Before the experiment they were kept on an initial purine-free diet, mainly of bread and milk. Their weight was recorded at regular intervals and showed that they were making satisfactory growth before and during the experimental periods.

A preliminary investigation, in which a number of puppies was allowed to eat a diet of bread, milk, and potatoes *ad libitum*, and on which they made satisfactory growth, showed us that about 100 calories per kilo of body weight could be considered as ample. Our experimental diets were consequently based on this figure. The following diets were used.

Diet.	Weight.	Content.			Calories.
		Protein.	Carbohydrate.	Fat.	
	<i>gm.</i>	<i>gm.</i>	<i>gm.</i>	<i>gm.</i>	
Initial purine-free.....		16.5	62.6	8.6	404.3
Milk.....	200				
Bread.....	100				
Meat.....		15.6	75.0	0.3	373.8
Potato.....	250				
Dextrin*.....	35				
Meat powder.....	15				
Placenta.....		15.6	75.0	0.4	373.9
Potato.....	250				
Dextrin*.....	35				
Placenta powder.....	15				

* Dextrin was sometimes replaced by corn-starch and occasionally in part by cane sugar.

The day's rations were divided into two portions, supplied in the morning and evening, and were greedily eaten by the puppies. The potatoes were always very thoroughly boiled, and whenever corn-starch was

used it was made into a paste before being mixed with the remainder of the diet. These details, although seemingly insignificant, proved to be essential to the success of the experiments.

Meat Preparation.

The meat powder was prepared from lean round steak. All visible fat and connective tissue were cut away, and the meat was passed through a mincing machine. The minced meat was then placed in boiling water for a period of 10 to 15 minutes. By means of cheese-cloth the coagulated mass was strained from the aqueous solution and much liquid fat. It was then reminced, and boiled again for a second and a third period. By this time practically all the fat and most of the extractives had been removed. After the last filtration, the remainder was spread out on coarse filter paper and rapidly air-dried at ordinary temperature. The brittle, dark brown material remaining was then ground to a fine powder in a mill and kept ready for use in tightly stoppered bottles. When wanted for use, the amount required was weighed out and allowed to absorb water before adding it to the potato and dextrin or corn-starch. A determination of nitrogen by the Kjeldahl method showed 13.6 per cent of the dried substance.

Placenta Preparation.

The placenta,⁴ immediately on delivery, was placed in a jar of sterile salt solution, covered by a layer of toluene, and the whole brought to the laboratory within a few hours. The fresh placenta was first washed free from large masses of clotted blood. Then the umbilical cord and free membranes extending beyond the mass of chorionic villi were cut off as short as possible. The placenta was next placed ventral side up in a large basin and the remaining membrane dissected away. It was found possible by this means to remove practically all the large blood vessels. The remaining mass was thoroughly washed under the tap, then torn up into small pieces and again washed, and finally strained through cheese-cloth. The product was then finely minced in a mincing machine, and the remaining blood was removed by placing this material in tall glass jars through which a stream of cold water constantly circulated. To prevent loss of material a piece of cheese-cloth was tied over the top of the jar. The washing occupied from 6 to 12 hours, depending on the condition of the placenta. The washed mass was filtered through cheese-cloth and then coagulated by immersion in boiling water, faintly acidified by acetic acid, for a period of 10 minutes. At this stage the coagulated placenta was again passed through a mincing machine and subjected to further boiling in water for another two periods of 10 minutes each. After the final boiling

⁴ The placentas were obtained from the Montreal Maternity Hospital, and our thanks are due to the authorities for their kindness and cooperation.

the mass was filtered at the pump, washed with distilled water, and air-dried. It was then ground to a fine powder in a mill, so that it passed through an 80 mesh sieve, and was preserved in stoppered bottles until required. About 1 kilo of material was thus prepared, representing forty-three placentas. A determination of nitrogen showed 13.7 per cent of the dry weight.

Total Purine Determination.

The two experimental diets are not purine-free. Both the meat and placenta contain nucleoproteins and water-soluble purines. The total purine content of muscle is given by Burian and Schur⁵ as about 0.055 gm. of purine nitrogen per 100 gm. of fresh tissue. Placenta has been examined by Wells and Corper⁶ who found 0.057 gm. of purine nitrogen in 100 gm. of fresh tissue. Thus, in the fresh state, the two tissues have practically identical purine contents. In both our diets, however, washing of the protein had been resorted to, and we felt it incumbent upon us to determine directly the purine content of our meat and placental powders.

30 gm. of meat or placental powder were boiled under a reflux condenser with 1 liter of 6 per cent sulfuric acid for 18 hours. The residue was filtered off and submitted to a further hydrolysis with 500 cc. of 5 per cent sulfuric acid for 12 hours. A slight residue from this hydrolysis was neglected. The filtrates were then neutralized separately by sodium hydrate and brought back to a condition of slight acidity with dilute acetic acid. They were next separately treated at the boiling point with copper sulfate as a 10 per cent solution and saturated sodium bisulfite solution, added alternately until a pronounced precipitate of cuprous oxide was visible. The filtrate from the second hydrolysis gave very little precipitate. The cuprous purine precipitates were united and decomposed in warm water by saturation with hydrogen sulfide. The filtrate and washings from this decomposition were next evaporated down to about 500 cc., and the purines again precipitated by copper sulfate and saturated sodium bisulfite solutions. The decomposition of the cuprous compounds was carried out as before, and the purine filtrates were concentrated to about 75 cc. This was washed into a 100 cc. volumetric flask quantitatively and diluted to the mark. A determination of nitrogen in the solution was made on aliquot parts by the Kjeldahl method and the results calculated as purine nitrogen.

30 gm. of meat powder gave 0.0360 gm. of N = 0.9 per cent of total N of meat.

30 gm. of placental powder gave 0.060 gm. of N = 1.47 per cent of total N of placenta.

Burian, R., and Schur, H., *Arch. ges. Physiol.*, 1900, lxxx, 241.

⁶Wells, H. G., and Corper, H. J., *J. Biol. Chem.*, 1909, vi, 469.

The two experimental diets thus differed in their purine-content by about 12 mg. per day. This small difference is insufficient to influence our results, for the differences which we have observed are far beyond that figure. In order to follow the influence of the placenta feeding upon the purine metabolism, we have determined the excretion of allantoin and of uric acid.

Urine Analysis.

The total nitrogen was determined by the Kjeldahl-Gunning process. The allantoin was determined by the process proposed by Plimmer and Skelton.⁷ We have found this method, or rather our variation of it, very useful; and if the allantoin is not too small in amount, it gives an accurate determination. The Folin magnesium chloride method for the determination of urea hydrolyzes urea and allantoin into ammonia which, together with the preformed ammonia, is distilled into an excess of standard acid from an alkaline solution. The urea and preformed ammonia were determined by the urease method devised by Van Slyke and Cullen.⁸ The difference gives the allantoin in terms of ammonia. We have modified the Folin magnesium chloride method⁹ to suit our own convenience. In its original form, in our hands, it always required constant attention. Our modification, though a little more time-consuming, can be left unattended while other work is proceeding.

Pipette 5 cc. of urine into a 200 cc. Erlenmeyer flask, and add 5 cc. of concentrated HCl from burette and 20 gm. of crystalline magnesium chloride, together with a small cube of paraffin wax about the size of a marble. The magnesium chloride should be ammonia-free or have its ammonia content determined by blank tests. It has been our experience that the commercial salt is more likely to be ammonia-free than the so called c. p. high priced article. A reflux condenser about 45 cm. in length and 1 cm. in diameter is attached to the flask and a large safety thistle tube to the upper end of the condenser. The safety tube also carries at the top a stopper with a glass tube bent at right angles. Without these safeguards we found it impossible to avoid loss by

⁷ Plimmer, R. H. A., and Skelton, R. F., *Biochem. J.*, 1914, viii, 70, 641.

⁸ Van Slyke, D. D., and Cullen, G. E., *J. Biol. Chem.*, 1914, xix, 211.

⁹ Folin, O., *Am. J. Physiol.*, 1905, xiii, 46.

spraying: Having the condenser jacket empty, a medium sized Bunsen flame is played over the bottom of the flask until the contents boil fairly vigorously. Regulating the flame to maintain this rate of ebullition, the evaporation is continued until marked frothing occurs. This takes about 5 to 10 minutes. By gradually reducing the size of the flame, the frothing is easily controlled, and the concentration is continued until the flame of 1 inch in height is reached. This heat just serves to keep the solution boiling and is maintained for a period of 2 hours. Occasionally very little frothing occurs, and in these cases the concentration is continued until each drop of liquid falling back from the condenser causes a marked spattering of the contents of the flask. Boiling gently for 2 hours continues from this point. The concentration to be aimed at is just short of saturation of magnesium chloride at that temperature. We have found that the primary boiling hydrolyzes the urea, and the second the allantoin. During the second period of boiling under constant conditions, a stream of cold water is run through the condenser. During this second period the determination requires no attention, as there is no danger under these conditions of the liquid in the flask becoming alkaline. At the end of 2 hours, the flask is allowed to cool, and the ammonia determined as in an ordinary Kjeldahl operation, using 10 cc. of 10 per cent sodium hydrate to render the contents of the distillation flask alkaline.

In order to prove the accuracy of this procedure for the determination of allantoin, it was deemed advisable to make tests on various concentrations of pure urea and allantoin solutions. The urea was determined by the urease method of Van Slyke and Cullen, while the Kjeldahl method of total nitrogen estimation served to check the mixed solutions. 2.5013 gm. of pure urea were dissolved in 100 cc. of distilled water and 0.5005 gm. of allantoin was dissolved in a like volume of water.

Urea determinations.

1. By urease method on 0.5 cc. of solution.

HCl N/20 cc.	NaOH N/20 cc.	Urea N mg. per cc.
10	1.65	
10	1.65	
10	1.58	
10	1.58	
Average		11.69

2. By Kjeldahl method on 5 cc. of solution.

	HCl $\frac{N}{10}$ cc.	NaOH $\frac{N}{10}$ cc.	Urea N mg. per cc.
	50	8.73	
	50	8.70	
Average.....			11.69
Calculated.....			11.68

Urea plus allantoin.

1. By modified method, using 5 cc. of urea + 5 cc. of allantoin solutions.

	HCl $\frac{N}{10}$ cc.	NaOH $\frac{N}{10}$ cc.	N mg. per cc.
	55	6.95	
	55	6.90	
Average.....			13.52

2. By Kjeldahl method.

	HCl $\frac{N}{10}$ cc.	NaOH $\frac{N}{10}$ cc.	N mg. per cc.
	50	2.00	
	50	2.10	
Average.....			13.54
Calculated.....			13.47
Allantoin determined.....			1.83
“ calculated.....			1.79

The pure solutions were next diluted ten times with distilled water and the determinations repeated omitting the Kjeldahl estimations.

Urea determinations.

1. By urease method on 0.5 cc. of solution.

	HCl 0.01973 N cc.	NaOH 0.02475 N cc.	N mg. per cc.
	25	18.22	
	25	18.24	
Average.....			1.157
Calculated.....			1.168

Urea plus allantoin.

1. By modified method on 5 cc. of urea + 5 cc. of allantoin.

	HCl $\frac{N}{10}$ cc.	NaOH $\frac{N}{10}$ cc.	N mg. per cc.
	10	3.80	
	10	3.85	
Average.....			1.342
Calculated.....			1.347
Allantoin determined.....			0.185
“ calculated.....			0.179

234 Placental Feeding and Purine Metabolism

TABLE I.
Urine Analysis.

Puppy W.											
Meat diet.					Placenta diet.						
Date.	Total N.	Urea N.	Creatinine N.	Allantoin N.	Uric acid N.	Date.	Total N.	Urea N.	Creatinine N.	Allantoin N.	Uric acid N.
1918	mg.	mg.	mg.	mg.	mg.	1918	mg.	mg.	mg.	mg.	mg.
Apr. 6	1,099	784.3	25.38	24.98	1.45	Apr. 13	Free day.				
" 7	1,032	651.2	24.83	72.80	0.33	" 14	1,615	1,154	25.65	92.45	9.25
" 8	1,689	1,113	24.30		1.00	" 15	1,503	955.4	25.70	215.01	8.44
" 9	Free day.					" 16	1,908	981.8	26.55	218.5	11.24
" 10	1,176	851.1	26.3	21.45	1.80	" 17	Free day.				
" 11	1,153	825.4	22.36	96.00	0.0	" 18	1,764	1,214	32.08	165.5	9.77
" 12	1,274	890.4	27.87	60.24	2.70	" 19	1,433	1,030	32.15	43.05	6.42
Average.....				55.09	1.21					146.91	9.02

TABLE II.
Urine Analysis.

Puppy G.											
Meat Diet.					Placenta diet.						
Date.	Total N.	Urea N.	Creatinine N.	Allantoin N.	Uric acid N.	Date.	Total N.	Urea N.	Creatinine N.	Allantoin N.	Uric acid N.
1918	mg.	mg.	mg.	mg.	mg.	1918	mg.	mg.	mg.	mg.	mg.
Apr. 6	1,033	626.1	20.27	42.55	0.23	Apr. 13	Free day.				
" 7	881	591.7	17.18	75.63	0.0	" 14	1,241	861.4	20.42	103.95	1.18
" 8	1,236	797.3	22.61	96.90	0.74	" 15	1,248	838.5	27.87	248.6	3.46
" 9	Free day.					" 16	1,319	864.4	24.05	107.2	4.18
" 10	1,172	828.7	24.38		0.0	" 17	Free day.				
" 11	1,180	960.5	24.05	136.50	1.67	" 18	1,122	893.0	25.37	71.29	5.11
" 12	1,293	916.4	24.50	52.65	1.83	" 19	1,193	837.0	22.73	62.40	3.76
Average.....				80.85	0.74					118.70	3.54

TABLE III.
Urine Analysis.

Puppy N.											
Meat diet.					Placenta diet.						
Date.	Total N.	Urea N.	Creatinine N.	Allantoin N.	Uric acid N.	Date.	Total N.	Urea N.	Creatinine N.	Allantoin N.	Uric acid N.
1918	mg.	mg.	mg.	mg.	mg.	1918	mg.	mg.	mg.	mg.	mg.
June 24	1,526	1,175	21.16	91.0	4.73	June 30	Puppy taking food normally.				
" 25	1,512	1,075	20.16	117.6	5.25	July 1	1,637	1,056	21.39	267.1	9.48
" 26	1,006	1,161	20.06	67.50	4.97	" "	1,758	1,224	24.23	228.0	8.27
" 27	Free day.					" "	1,541	988	23.10	241.0	8.46
" 28	1,602	1,050	20.34	141.7	5.14	" 4	Free day.				
" 29	Puppy not taking food.					" 5	1,474	1,037	27.36	182.0	8.75
						" 6	1,496	960	28.78	182.0	8.15
Average											
										220.2	8.62
										111.0	5.5

Uric acid was determined colorimetrically by the Folin-Macallum¹⁰ method as modified by Benedict and Hitchcock.¹¹ In the earlier part of the experiments, we were much troubled by turbidity arising in the solutions, but on using the modified Benedict uric acid reagent,¹² this difficulty disappeared.

As a check on the collection of urine, creatinine was determined by the micro method of Folin,¹³ using creatinine zinc chloride as a standard, and picric acid purified according to the method of Folin and Doisy.¹⁴ The creatine determinations also formed an essential part of the investigation on creatinuria. The urines were preserved under toluene and all analyses were carried out within 36 hours. With the diets adopted we were untroubled by any fecal contamination of the urine. Glucose was absent from all urines as judged by Benedict's qualitative test. Likewise acetoacetic acid was never observed, although tested for by the nitroprusside method of Harding and Ruttan.¹⁵ The results are given in Tables I to III.

The protocols of the allantoin determinations and the weight records are appended in Tables IV, V, and VI.

TABLE IV.
Weight Records.

Date.	Puppy W.	Puppy G.	Date.	Puppy N.
<i>1918</i>	<i>gm.</i>	<i>gm.</i>	<i>1918</i>	<i>gm.</i>
Apr. 3	2,935	2,650	June 20	2,840
" 6	3,010	2,695	" 26	3,105
" 10	3,100	2,730	" 30	3,140
" 13	3,165	2,790	July 4	3,160
" 17	3,320	2,855	" 8	3,250
" 20	3,400	2,975	" 11	3,460
			" 15	3,270
			" 17	3,410

¹⁰ Folin, O., and Macallum, A. B., *J. Biol. Chem.*, 1912, xi, 265.

¹¹ Benedict, S. R., and Hitchcock, E. H., *J. Biol. Chem.*, 1915, xx, 619.

¹² Newirth, I., *J. Biol. Chem.*, 1917, xxix, 478 (Note 4).

¹³ Folin, O., *J. Biol. Chem.*, 1914, xvii, 469.

¹⁴ Folin, O., and Doisy, E. A., *J. Biol. Chem.*, 1916-17, xxviii, 349.

¹⁵ Harding, V. J., and Ruttan, R. F., *Biochem. J.*, 1912, vi, 445.

TABLE V.
Allantoin Determinations.

Date.	Puppy W.			Puppy G.		
	HCl N/10	NaOH N/10	Allantoin N.	HCl N/10	NaOH N/10	Allantoin N.
<i>1918</i>	<i>cc.</i>	<i>cc.</i>	<i>mg. per cc.</i>	<i>cc.</i>	<i>cc.</i>	<i>mg. per cc.</i>
Apr. 6	25	1.90	0.18	25	1.70	0.38
	25	1.87		25	1.68	
" 7	25	3.52	0.56	30	4.20	0.79
	25	3.50		30	4.20	
" 8				25	3.25	0.58
				25	3.20	
" 10	25	7.06	0.11			
	26	8.13				
" 11	25	13.80	0.30	25	13.80	0.42
	25	13.85		25	13.75	
" 12	25	9.50	0.25	25	9.20	0.27
	25	9.55		25	9.30	
" 14	50	4.58	0.86	25.5	2.85	0.63
	50	4.60		25.5	2.83	
" 15	75	18.75	2.47	25	3.43	1.28
	75	18.70		25	3.47	
" 16	25	28.30	0.87	25	8.50	0.46
	25	28.32		25	8.30	
" 18	25	0.37	0.77	25	6.20	0.36
	25	0.37		25	6.30	
" 19	25	3.69	0.21	25	2.85	0.40
	25	3.65		25	2.90	

TABLE VI.
Allantoin Determinations.

Puppy N.				
Date.	HCl N/10	NaOH N/10		Allantoin N.
		1	2	
<i>1918</i>	<i>cc.</i>	<i>cc.</i>	<i>cc.</i>	<i>mg. per cc.</i>
June 24	25	12.15	12.20	0.201
" 25	25	3.15	3.15	0.492
" 26	25	4.30	4.20	0.250
" 28	25	3.50	3.45	0.545
July 1	25	13.45	13.35	0.490
" 2	25	10.70	10.70	0.480
" 3	25	8.70	8.65	0.700
" 5	25	11.85	11.95	0.449
" 6	25	12.25	12.25	0.462
" 8	25	15.05	15.00	0.274
" 9	25	16.45	16.65	0.228
" 10	25	11.70	11.70	0.286

DISCUSSION.

It is evident from an inspection of the figures given in Tables I to III that the feeding of placenta resulted in an increase in the excretion of both allantoin and uric acid. The smallest rise is shown by Puppy G, but even here the result is beyond the range of experimental error. Large fluctuations occur in the allantoin excretion; so large that in two cases the variations overlap in the two experimental periods, and at first led us to believe that there was something fundamentally wrong with our analytical technique. A revision of this, however, failed to show any serious error from this source except that it was realized afresh that extreme care must be taken over the allantoin determinations when there was only a small amount present. As a further check, however, the uric acid was determined. This, in the case of Puppies W and G, was made some weeks after the other analyses, but in Puppy N it was carried out concurrently with them. As the uric acid figures show a similar increase during the period of placental feeding, we were confirmed in our opinion that the latter diet resulted in an increase in purine metabolism when contrasted with meat or muscle feeding. Furthermore, in Puppy N a return to the original meat diet led to a prompt drop in the allantoin and uric acid to their original level. The increase on the placenta diet is too large to be ascribed to the difference in purine content of the two diets. In the meat diet 18 mg. of purine N were supplied per day; in the placenta diet this was increased to 30 mg. per day, giving the small difference of 12 mg. of purine N in favor of the placenta diet. This was the same for each puppy. The total increase in purine N estimated in the urine (allantoin N plus uric acid N) was 41.65, 99.63, and 118.60 mg. respectively for Puppies G, W, and N.

The possibility, too, of increased purine catabolism due to mere stimulation may also be dismissed. Both diets possessed the same nitrogen content, both were equally well absorbed, and similar amounts of nitrogen were found in the urines of the two periods. Both meat and placenta had been deprived of their extractives by water. It would appear then that the cause of the difference in the purine excretion under the two diets must be sought in their amino-acid make-up.

In an important paper entitled "Feeding experiments with deficiencies in the amino-acid supply: arginine and histidine as possible precursors of purines," Ackroyd and Hopkins,² as mentioned before, came to the conclusion that these two amino-acids either together or separately can act as the raw material for the synthesis of purines in the animal body. It is a generally accepted fact that such a synthesis occurs, and naturally the presence of the glyoxaline ring in both purines and histidine, and a similarity of arrangement of carbon and nitrogen atoms in arginine and the pyrimidine nucleus, had long ago pointed to these two particular amino-acids as the probable source of such a synthesis. Abderhalden together with Einbeck¹⁶ and Schmid¹⁷ had attempted to obtain experimental evidence in favor of such a connection without success. Ackroyd and Hopkins owe their positive evidence to a better selection of experimental conditions. They point out that in the adult animal such a synthetic process is of necessity at a minimum, and the evidence may well escape observation. Also that to supply an animal either in full-nutrition or in a fasting condition with a large amount of an amino-acid suddenly is to supply it in excess of its current needs and to insure its catabolism by the most rapid path. If there now exists any alternative, a path involving a synthesis would be avoided.¹⁸

In their evidence, Ackroyd and Hopkins observe the effect on growth and upon the excretion of allantoin in the growing rat of the withdrawal of arginine and histidine from the diet. The original diet, which was entirely adequate, contained caseinogen as its protein. The caseinogen was hydrolyzed by acid and tryptophane and cystine was added, thus rendering it complete in regard to its amino-acid make-up. On this diet the rats made satisfactory though not entirely normal growth. The removal of arginine and histidine led to a prompt loss in body weight and a

¹⁶ Abderhalden, E., and Einbeck, H., *Z. physiol. Chem.*, 1909, lxii, 322.

¹⁷ Abderhalden, E., Einbeck, H., and Schmid, J., *Z. physiol. Chem.*, 1910, lxxviii, 395.

¹⁸ The acceptance of this argument involves the assumption of the rapid adaptability of the organism. Otherwise the presentation of a large amount of a particular amino-acid would involve its metabolism by all paths in accordance with the active masses of material and the relative rates of the chemical reactions.

fall in the allantoin excretion of 40 to 50 per cent. The withdrawal of only one of the two amino-acids, however, was followed by maintenance of weight, occasionally with a slight rise, and a drop in the allantoin excretion of about 17 per cent. It would seem as though arginine or histidine acted independently as an essential amino-acid, and functioned as a raw material for the synthesis of the purine ring in the growing rat. The fall in allantoin excretion is not a direct outcome of the drop in body weight occurring on the withdrawal of arginine and histidine, as the removal of tryptophane from the diet occasions a loss in weight without a corresponding decrease in the allantoin excretion, although irregularities in the purine metabolism were noticed in one case.

In attempting to contrast our two experimental diets, we were surprised to find no analysis of lean round steak made according to the Van Slyke method. We therefore utilized as the basis of our calculations the results of Thrun and Trowbridge¹⁹ on a veal composite. In Table VII is given the amino-acid content of meat and placenta diets calculated in this way. We have also included the average results of two analyses of human skeletal muscle made by Drummond.²⁰ The figures for the veal composite and human muscle do not differ markedly.

An inspection of the table shows that the meat diet is high in lysine as compared with the placenta diet and low in arginine. Taking its arginine and histidine content together, the placenta diet represents an increase of 50 per cent. As no special function has as yet been discovered for lysine, and as the results show that an interpretation of our experimental figures must be sought in an increment in the placental diet, we are inclined to look upon our results as strongly supporting those of Ackroyd and Hopkins. We should also like to emphasize that in our experiments the uric acid excretion was increased, as well as the allantoin excretion, during the period of placental feeding. This we think important in view of the results of Benedict²¹ on the purine metabolism of the Dalmatian hound in which the allantoin and the uric

¹⁹ Thrun, W. E., and Trowbridge, P. F., *J. Biol. Chem.*, 1917, xxxiv, 343.

²⁰ Drummond, J. C., *Biochem. J.*, 1916, x, 473.

²¹ Benedict, S. R., *J. Lab. Clin. Med.*, 1916-17, ii, 1.

acid do not always follow parallel excretory paths. The increase in the uric acid shows unmistakably, in our minds, a synthesis of an actual *purine* ring.

Moreover, it should be again pointed out that in our experiments the animals were in full nutrition, as evidenced by their growth records. The high arginine and histidine diet resulted in an increase in the synthetic processes. In this respect our experiments differed markedly from those of Ackroyd and Hopkins, and our results are not in accordance with some of the postulates expressed in that paper.

TABLE VII.

Nitrogen partition.	Placenta (Harding and Fort). ¹	Placenta diet.	Veal com- posite* (Thrun and Trow- bridge).	Meat diet.	Human skeletal muscle (Drum- mond).
	<i>per cent</i>	<i>mg. per day</i>	<i>per cent</i>	<i>mg. per day</i>	<i>per cent</i>
Arginine N.....	22.54	450.8	13.3	266.0	11.17
Histidine N.....	3.12	62.4	5.0	100.0	4.25
Lysine N.....	7.22	144.4	13.5	270.0	13.15
Cystine N.....	1.36	27.2	1.00	20.0	0.85
Monoamino N.....	51.15		60.50		58.00
Non-amino N.....	5.85				4.30

* Calculated from figures given in Table II, by Thrun, W. E., and Trowbridge, P. F., *J. Biol. Chem.*, 1917, xxxiv, 351.

Lastly, how far these results may be taken as indicative of a function of the placenta is a matter for further experimental inquiry. It is certain that the high arginine content of the placenta, its ready hydrolysis by all classes of proteoclastic enzymes,²² and the formation of allantoin and uric acid in feeding experiments with the young dog would go to show that one of its possible functions may be to act as a reserve store of arginine for purine synthesis in the fetus. The results of Lewis and Doisy,²³ who by feeding men diets high in arginine and histidine were unable to obtain any increase in the uric acid output, need not be considered as antagonistic to our view. With adolescence may come a cessation or an impairment of the synthetic processes.

²² Harding, V. J., and Young, E. G., *J. Biol. Chem.*, 1918, xxxvi, 575.

²³ Lewis, H. B., and Doisy, E. A., *J. Biol. Chem.*, 1918, xxxvi, 1.

SUMMARY.

From comparative feeding experiments on young dogs with equivalent diets containing muscle protein and placenta protein, the excretion of allantoin was found to rise markedly on the placenta diet.

The excretion of uric acid parallels that of allantoin and the conclusion is drawn that the comparatively large amount of arginine present in the placental diet is responsible for the increase in purine metabolism.

A modification of the Plimmer and Skelton method of determining allantoin is described and proofs of its accuracy are given.

THE EFFECTS OF MALT AND MALT EXTRACTS ON SCURVY AND THE ALKALINE RESERVE OF THE BLOOD.

By J. F. McCLENDON, W. C. C. COLE, O. ENGSTRAND, AND J. E. MIDDLEKAUFF.

(From the Physiological Laboratory of the University of Minnesota Medical School, Minneapolis.)

(Received for publication, August 25, 1919.)

It has been well established that scurvy may be prevented or cured by eating fresh raw food. The object of the present paper is to determine whether, in the entire absence of fresh foods, scurvy may be prevented or cured by malt products suitable for food for infants and adults. Cereal grains may be easily transported and stored so as to preserve their sprouting capacity and there would be no necessity of a shortage of them, and hence no necessity of scurvy if the scurvy-ridden communities knew how to use them. Wiltshire has shown that human scurvy may be cured with sprouted beans, and Greig advocates their use in the army, but one of us has tested the sprouting of beans in army camps and under various climatic conditions and found them far less resistant to mould than are any of the cereal grains except maize. Germination tests on many samples of beans bought from civilians showed that they were incapable of sprouting under any conditions. Army beans that showed over 90 per cent germination were attacked by mould if the temperature rose above 15° at night.

The relative importance of this work depends on the prevalence of scurvy, but we have not been able to obtain complete information on this subject. During the Civil War 30,741 cases of scurvy among white troops were recorded. Bruntz and Spillmann designate "trench-foot" as a prescorbutic condition. Many cases of scurvy have been diagnosed as such only after treatment on the supposition that the lesions were due to another cause.

Durand finds that canned milk (which has been repeatedly shown to be deficient in antiscorbutics) causes dental caries in

infants. In examinations of young children whose infant histories were known, 53 to 74 per cent showed dental caries following a diet of canned milk, whereas breast-fed children showed 28 to 42 per cent dental caries. If the soundness of teeth depends on antiscorbutics in the diet, the subject is one of greater importance than it has generally been considered.

Soon after Holst and Fröhlich in Norway began their work on scurvy in guinea pigs, Fürst, working in their laboratory, showed that fresh sprouted barley is sufficient in antiscorbutic principles, but that these properties are lost in the drying of the malt, as is usually done in the beer industry. Weill and Mouriquand have disputed the fact that sprouting barley contains antiscorbutic substances but they admit that the young barley plant is effective in this way. Chick and Hume, and Cohen and Mendel have also found antiscorbutics in sprouting grains (oats, barley).

Since barley grains yield an acid ash and Wright has claimed that scurvy is the result of acidosis, we eliminated this possible objection by determinations of the alkaline reserve of the blood in scurvy as compared with that in health. We used guinea pigs because they are the classical animals for the study of scurvy and also rabbits since they are particularly susceptible to acidosis. In order to control the ash of the food we took two equal weights of barley, sprouted one part, and fed it to one animal, and fed the other part, unsprouted, to an animal of the same size. Brown has shown that the barley grain loses or gains no salts by steeping as long as it is alive and that the salts gained by the steep water come from the husk. Since guinea pigs do not eat the husk, we assume that the one eating dry barley gets the same salts as the one eating the same weight of sprouted barley. The guinea pigs were kept in cages of $\frac{1}{4}$ inch wire screen, with partitions so that each guinea pig had a separate compartment. They learned to drink out of inverted tubes filled with water.

The barley was sprouted by the drum method, large, wide-mouthed glass jars serving as drums. The jars were placed on two parallel steel shafts, 2 cm. in diameter, 200 cm. long, and placed 10 cm. apart. Both shafts were rotated in the same direction by means of a small electric motor and worm-gear. The friction of the shafts on the jars caused them to rotate very slowly. Cool, moist air was supplied by means of an aspirator pump and trans-

mitted by tubes projecting into the mouths of the jars. Two adjacent jars were placed with their mouths facing one another and air was supplied to both of them by means of a T-tube. Seed barley¹ was placed in a jar together with the amount of water it would absorb in 24 hours rotation, and at the end of that time it was washed, drained, and the rotation continued until the sprouting was complete. If the temperature within the jar approached 30° during the first 48 hours, death of some grains might occur, but after the first 48 hours (or, more correctly, after the

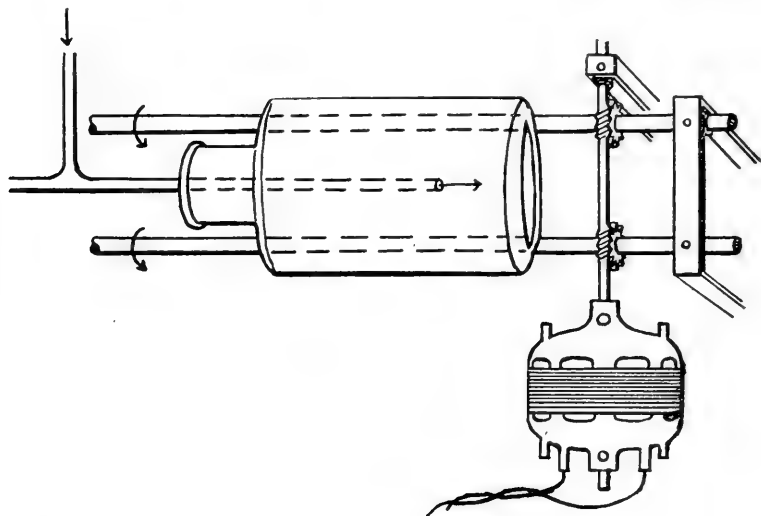

FIG. 1.

acrosipre appeared), the temperature might be raised to 30° with impunity. Since rise in temperature decreases the time required for sprouting, we never let it fall below 20°. The original design of the apparatus is shown in Fig. 1.

In determining the alkaline reserve, twelve guinea pigs and six rabbits were used. The animals were weighed every day, but the weight curves in this paper are smoothed so as to obliterate the confusing details since we were unable to compare the curves

¹ We are indebted to the cooperation of Professor A. C. Army for the seed barley.

in their original form. The weight curves of the guinea pigs are shown in Fig. 2. The spaces on the ordinate represent differences of 100 gm. in weight, and the spaces on the abscissa intervals of 30 days. The curves of the animals fed on sprouted barley (with aerspire 1 inch long) are represented by unbroken lines, and the curves of the animals on dry barley by broken lines. The animals are numbered 1 to 6 beginning with the smallest (200 gm.) at the left. It may be seen that the animals on sprouted grain lost little if anything in weight, whereas those on dry grain lost rapidly.

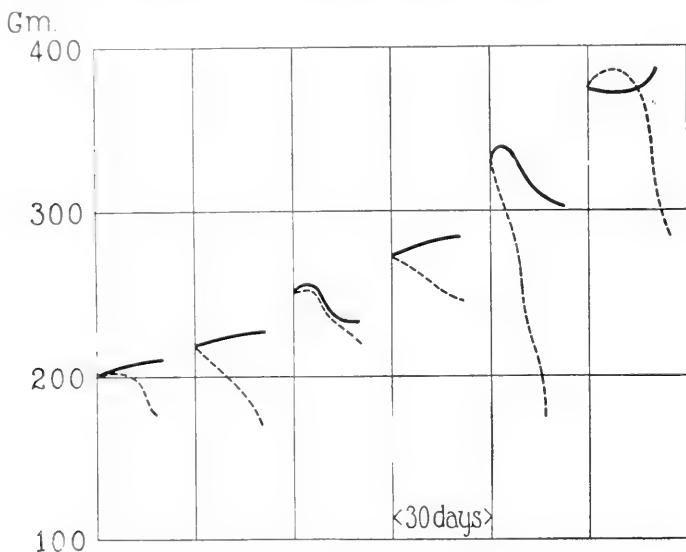

FIG. 2.

This was not due to lack of water as both sets were supplied with water *ad libitum*, and the dry grain was fed in a dish of water. The fifth guinea pig on dry grain died in 17 days, the remaining were bled to death in 20 to 25 days, and all showed hemorrhages characteristic of scurvy. None of the guinea pigs on sprouted grain showed scurvy symptoms.

The alkaline reserve was determined by a modification of the Van Slyke, Stillman, and Cullen method. We found their method satisfactory, but modified it a little so as to compare more readily our previous data with the present determinations.

Neutral red fades in the standard solutions and we found that dibromothymolsulfonephthalein was more permanent and gave striking color changes, but we did not have enough of it and confined our determinations to neutral red, making new standards every day. For standards, we used the borax mixtures of Palitzsch since they are better and cheaper than phosphate mixtures. Since Palitzsch does not show the continuous curve for these mixtures, and we determined ours with the hydrogen electrode, we give the following directions for making them.

We made stock solutions of 0.05 molecular borax and 0.2 molecular boric acid and protected them in resistance glass flasks with automatic burettes with soda-lime tubes. We used reagent borax dried in air as it came from the manufacturer, noting that none of the crystals was moist or had effloresced. We recrystallized the boric acid and dried it in a desiccator. The water was freshly distilled and CO₂-free air was blown through it for 15 minutes. The following table shows the pH and the per cent of the borax stock solution, the remainder being boric acid stock solution.²

pH.	6.6	6.7	6.8	6.9	7.0	7.1	7.2	7.3	7.4	7.5	7.6	7.7	7.8	7.9
Per cent of borax.	2.5	2.7	3.2	3.9	5.0	6.1	7.4	9.9	10.6	12.7	15.1	17.7	20.5	23.7
pH.	8.0	8.1	8.2	8.3	8.4	8.5	8.6	8.7	8.8	8.9	9.0	9.1	9.2	
Per cent of borax.	27.3	30.9	35.2	39.7	44.4	49.3	54.7	60.7	67.4	74.5	81.5	89.2	96.8	

We found that the dilution of plasma recommended by Van Slyke is sufficient, as we got practically the same results with double or quadruple that dilution, but that the CO₂ remaining in the plasma after rotation made a difference of about two drops in the titration. This is no objection to Van Slyke's method, but we wished to blow out the CO₂ as thoroughly as we did in the electrometric method in order to compare results by the two methods. The flask was rotated by an electric motor while a stream of CO₂-free air was blown through it, as shown in Fig. 3.

² We are indebted to Professor Grace Medes for most of the work in preparing the standards.

248 Effects of Malt and Malt Extracts on Scurvy

The method may be summarized as follows: Tubes were prepared for the blood by drying in them enough 25 per cent potassium oxalate solution to make 0.2 per cent dry oxalate in the blood. The animal was anesthetized lightly with ether and the blood was drawn from the left ventricle (carotid in rabbits) and centrifuged immediately. 1 cc. of plasma was introduced in a 100 cc. flask of resistance glass and 20 cc. of distilled water, 0.3 cc. of 0.1 per cent solution of neutral red, and 3 cc. of 0.01 N HCl were added. Three similar flasks were made up with 25 cc. of

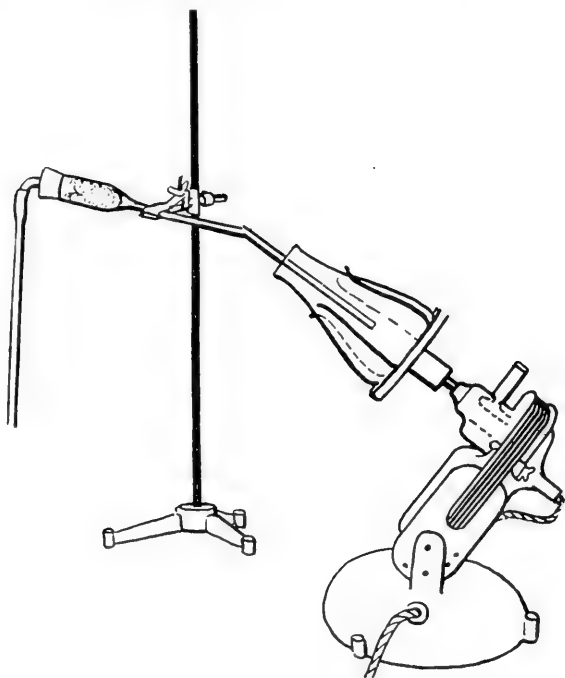

FIG. 3.

standard solution and 0.3 cc. of indicator in each, showing pH = 6.6, 7.0, and 7.4. The plasma flask was rotated 5 minutes and, if the color came within range of the standards, more acid was added, but it is not necessary normally to add more acid. The plasma was then titrated in the same flask with 0.01 normal solution of CO_2 -free NaOH to the three standard colors in succession. Both

acid and alkali were made up with CO₂-free distilled water and kept in automatic burettes that fill from the top so that the solutions do not pass through a greased stop-cock before entering the burette.

The following table shows the alkaline reserve in terms of a normal solution, as titrated to the three standards. Owing to changes in ionization by dilution, we prefer not to say what pH is the correct end-point, but any end-point may be noted by drawing a curve through the three points.

No.	Scurvy guinea pigs (dry barley). [*]			Controls (barley with 1 in. sprouts).		
	pH			pH		
	6.6	7.0	7.4	6.6	7.0	7.4
1	0.026	0.024	0.021	0.016	0.014	0.012
2	0.021	0.019	0.017	0.018	0.016	0.014
3	0.034	0.032	0.026	0.021	0.019	0.017
4	0.020	0.019	0.017	0.020	0.019	0.017
5				0.022	0.021	0.019
6	0.022	0.020	0.017	0.019	0.018	0.016

It may be seen from the table that with the exception of Scurvy Guinea Pig 3, which was in a moribund condition with dark venous blood, there is no essential difference between the alkaline reserve of those with and without scurvy. If the alkaline reserve changed during ether anesthesia, and differently in different individuals, that would account for the slight differences shown, but not for the similarities of the two groups. We must conclude that acidosis has nothing to do with scurvy in the guinea pig.

The weight curves of the rabbits are shown in Fig. 4, those on sprouted grain are shown by unbroken lines and those on dry grain by broken lines. The spaces on the ordinate represent differences of 300 gm. in weight, and the space on the abscissa represents an interval of 20 days. The rabbits were numbered 1 to 3 beginning with the pair at the top (900 gm.). The rabbits on sprouted barley remained nearly constant in weight, while those on dry barley lost and two of them died before blood was drawn. The 900 gm. rabbit on dry grain showed scurvy lesions when blood was drawn on the 21st day. Before the beginning of the experiment, all the rabbits had been kept together and fed on oats and

250 Effects of Malt and Malt Extracts on Scurvy

hay. Hence they were particularly susceptible to a scorbutic diet. The alkaline reserve is shown in the following table.

No.	Scurvy rabbits (dry barley).			Controls (barley with 1 in. sprouts).		
	pH			pH		
	6.6	7.0	7.4	6.6	7.0	7.4
1	0.008	0.006	0.003	0.009	0.008	0.004
2				0.011	0.010	0.008
3				0.007	0.006	0.004

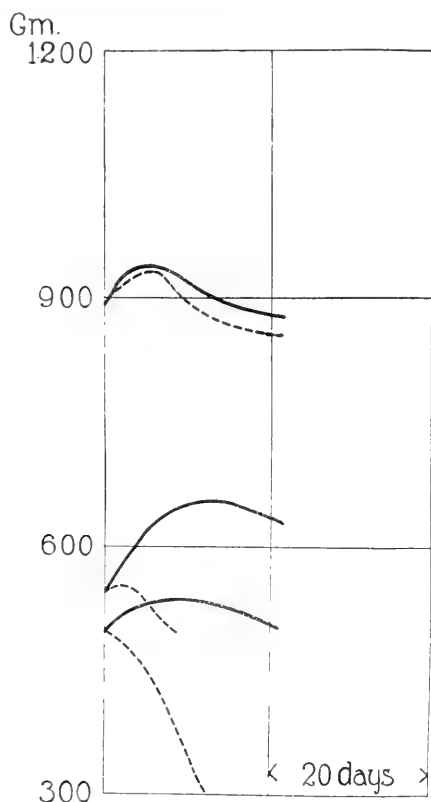

FIG. 4.

In our previous determinations on rabbits fed on carrots and hay (McClendon, von Meysenbug, Engstrand, and King), the

alkaline reserve was found to be about 0.020, and hence both sets of the above rabbits show acidosis due to the deficiency of alkali in the exclusive barley diet. The scurvy rabbit does not show a significant difference in alkaline reserve from the controls, and therefore we may conclude that acidosis has nothing to do with scurvy in rabbits, but may be a factor in the early death of the animals.

According to Fürst, barley sprouted for 3 days prevents scurvy, whereas Weill and Mouriquand found that 10 days sprouting was required. These workers do not record the temperature, and since the rate of sprouting is more than doubled by a rise of 10° in temperature, it is necessary to control and record the temperature or determine the degree of sprouting by the length of root and acrospire. In the following experiment an attempt is made to determine the degree of sprouting and quantity of malt necessary to prevent scurvy in the guinea pig, but an epidemic of pneumonia made the data fragmentary.

In this experiment barley seedlings of three ages were used (1 day, 2 days, and 3 days). In 1 day the roots were $\frac{1}{8}$ inch in length, in 2 days the acrospire was visible, and in 3 days the acrospire projected $\frac{1}{2}$ inch beyond the grain. The growth curves of the guinea pigs are shown in Fig. 5. Fifteen of these guinea pigs were divided into five sets, numbered 1 to 5, and arranged from left to right (Fig. 5). The curves of the guinea pigs fed on 1 day sprouts are shown by unbroken lines, those on 2 day sprouts by broken lines, and those on 3 day sprouts by dotted lines. The divisions on the ordinate represent differences of 100 gm. in weight, and those on the abscissa intervals of 30 days. The first set was fed 1 gm. of sprouts, the second set 2 gm., the third set 3 gm., the fourth set 4 gm., and the fifth set 5 gm. per 100 gm. of body weight of guinea pig per day, and they had oats and water *ad libitum*.

It may be seen from the curves that nearly all the guinea pigs began to gain in weight and then to lose; the end of the curve represents the early death. Besides this series, one guinea pig, represented by the chain of circles in Fig. 5, was fed oats and 2 day sprouted barley *ad libitum* and he ate less than 25 gm. per day of the latter. He died at the end of 33 days with no symptoms of scurvy. The fact that guinea pigs of this weight die of scurvy

252 Effects of Malt and Malt Extracts on Scurvy

in about 20 days indicates that 2 day sprouts contain an appreciable amount of antiscorbutic substance. Another guinea pig, represented by the chain of crosses in Fig. 5, was fed oats and 3 day sprouted barley *ad libitum*, and ate less than 25 gm. per day of the latter. He gained in weight for 32 days. The decline in weight following was apparently accompanied by an infection that caused death of some of the guinea pigs, but was manifested by a coryza and dyspnea in this one. At the end of the 48th day we discontinued the oats and gave him the sprouts and autoclaved

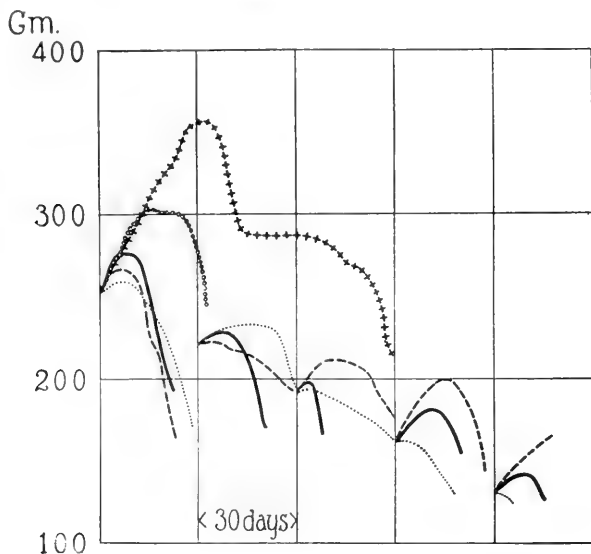

FIG. 5.

biscuit containing condensed milk for a few days, and then fed him exclusively on sprouted barley and water until he died at the end of 90 days without symptoms of scurvy. Since barley is deficient in salts, protein, and fat-soluble A, as shown by Steenbock, Kent, and Gross, and salts, at least, cannot be synthesized in the sprouting of the barley, the death of this guinea pig might have been due to lack of salts.

Since the above experiments show that barley, sprouted until the aerspire is $\frac{1}{2}$ inch long or longer, contains considerable antiscorbutic substance (and the same is true of other grains) efforts

were made to prepare sprouted grain for human food and yet preserve the antiscorbutic substance. The husks of barley make it poor eating, but wheat and rye offer no mechanical difficulties. If sprouted wheat and rye are heated to 70° , the starch is gelatinized and it may be eaten as a salad or breakfast food. Three guinea pigs were fed exclusively with wheat and rye sprouted until the acrospire projected $\frac{1}{2}$ inch beyond the grain and placed in water of 70° until the starch was gelatinized. Their growth curves are the first three beginning at the left in Fig. 6. The weight is marked on the ordinate and the divisions on the abscissa represent intervals of 30 days. None of these animals showed symptoms of scurvy, but two of them died rather early. The

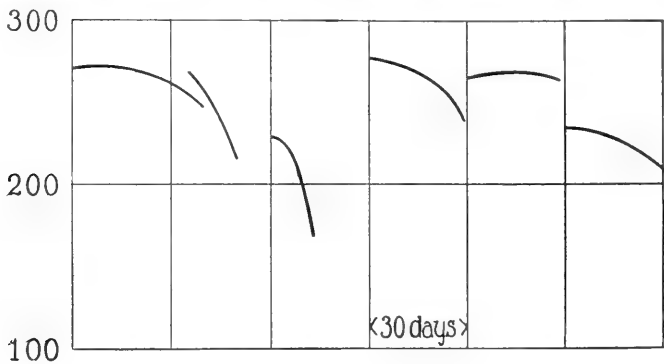

FIG. 6.

fact that one of them lived 34 days and showed no scurvy symptoms at autopsy shows that the sprouted wheat and rye contain antiscorbutic substances which are not destroyed by heating to 70° to gelatinize the starch. Another guinea pig shown in Fig. 8 was cured of scurvy by a similar diet.

Since the whole grain cannot be fed to infants, we attempted to prepare a juice containing the antiscorbutic substance. Since the antiscorbutic substance probably exists in the cells of the acrospire or roots, and it is difficult to crush these cells, we used a special mill for the purpose, shown in Fig. 7. This mill has polished steel rollers, 2.25 inches in diameter, and differs from an ordinary malt mill in that the rollers are geared to one another and there are scrapers to remove the crushed sprouts. A pulley wheel, 2 feet in diameter, was fitted to one of the rolls and driven

by a belt. Sprouted wheat or rye showed a tendency to slide out of the groove between the rolls, but sprouted barley fed well into the mill owing to the roughness of the husk. After the sprouted barley was crushed between the rolls it was placed in a canvas bag in a press capable of exerting a pressure of 5,000 pounds to the square inch. It was found, however, that very little juice came out of it at full pressure and a new bag had to be used each time. By adding water before pressing, less pressure was sufficient and the bag lasted longer.

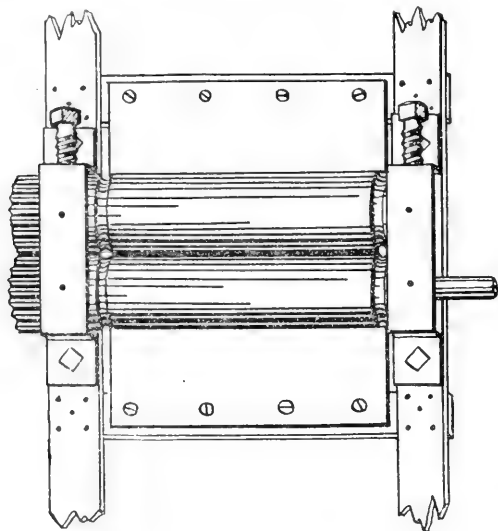

FIG. 7.

Three guinea pigs, whose weight curves are shown in the right half of Fig. 6, were fed with the juice of barley with the acripsire $\frac{1}{2}$ inch beyond the grain and water *ad libitum*. They almost maintained their weight, lived about 30 days, and showed no signs of scurvy at autopsy. One guinea pig, shown in Fig. 8, was cured of scurvy with this juice. This indicates that the juice contains sufficient antiscorbutic substance. It has a grassy taste, but probably could be fed to babies without much difficulty. No doubt the grain could be practically freed from bacteria before sprouting (Duggar and Davis).

Since very little starch is hydrolyzed during the sprouting and most of it remains in the press, an attempt was made to mash the green malt so that the carbohydrate would appear in the extract. Barley with sprouts $\frac{1}{2}$ inch long (aerospire extending $\frac{1}{2}$ inch beyond the grain) was crushed by passing it through a clothes wringer with rubber rolls, mixed with twice its weight of water, and heated to 70° to gelatinize the starch. It was allowed to remain in the same vessel until the starch iodide reaction disappeared, which required about an hour, and then strained and pressed so that the extract ran into a glass distilling flask with a side neck. A rubber stopper was inserted through which passed a capillary tube extending to the bottom of the flask. The flask was placed in a water bath, heated to 70° , and suction was applied to the side neck so as to evaporate the contents. A fine stream of air bubbles, liberated from the end of the capillary tube, prevented bumping. When the malt extract was evaporated to the consistency of a very thick syrup, *i.e.* the thickest syrup that could easily be removed from the flask, it was stored in glass jars until used. A slight amount of oxidase remained in the extract and caused a very slow darkening of the surface exposed to air. Fermentation was prevented by the evaporation, but mould would grow very slowly on the surface if planted there. Some of this extract has been kept for 5 months in good condition.

The weight curves of the guinea pigs fed on this malt extract are shown in Fig. 8. The body weight is marked on the ordinate, and the divisions on the abscissa represent intervals of 25 days. The guinea pigs were divided into six pairs which were fed on increasing quantities of extract from left to right, 0, 5, 10, 15, 20, and 25 gm. per guinea pig per day mixed with a dough or mush. The mush for one guinea pig consisted of 12 gm. of Graham flour, 12 gm. of rolled oats, 12 cc. of evaporated milk, and 1 cc. of a salt solution containing 25 per cent NaCl and 6 per cent CaCl₂, together with the designated quantity of extract. The mixture was a mush only with the larger quantity of extract, and a stiff dough with the smaller quantities. Water was given *ad libitum* as in all the above experiments. All the animals lost weight finally, although they ate greedily until they all showed symptoms of scurvy (tender swollen joints, falling hair, and loose molars) at about the 15th day, after which they ate less. The larger guinea pig of the fourth

256 Effects of Malt and Malt Extracts on Scurvy

pair showed marked scurvy on the 16th day and was transferred to a diet of sprouted wheat and rye heated to 70° , as shown by the broken line continuation of his curve in Fig. 8. He gained considerably in weight, and the scurvy symptoms rapidly disappeared so that none was found at the autopsy on the 26th day. This indicates that the process of heating to 70° to gelatinize the starch does not destroy the antiscorbutic substance. The reason all the

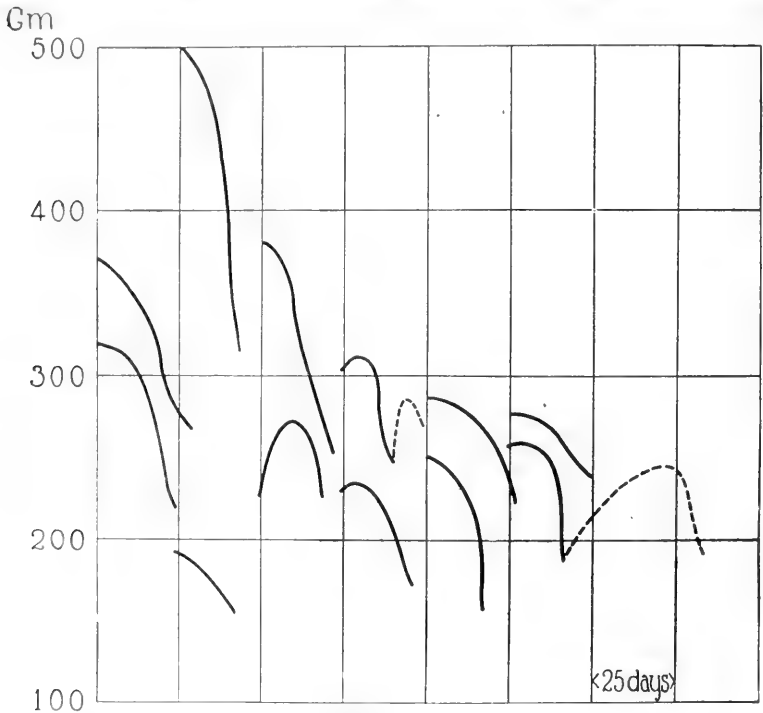

FIG. 8.

animals developed scurvy may lie in the possibility that the sprouts were not sufficiently crushed and the antiscorbutic substance was never extracted from them. The smaller guinea pig of the sixth pair developed marked scurvy with swollen wrists (which when touched provoked a squeal), loose molars, and bloody diarrhea. About the 20th day he could scarcely move about his cage and was changed to a diet of raw juice of sprouted barley crushed between steel rolls, as shown by the broken line continuing

his curve in Fig. 8. He gained rapidly in weight and lost all scurvy symptoms but finally began to lose and died on the 60th day showing no signs of scurvy on autopsy.

With the exception of the two animals cured of scurvy, the diagnosis of scurvy in all of the twelve was confirmed on autopsy. The first pair, receiving no malt extract, lost weight but little more rapidly than the average of those fed extract. Since Fürst has shown that commercial malt extract is deficient in antiscorbutic substance, and the same is true of beer according to Smith, it seems probable that the only way to get the antiscorbutic substance into the extract is to crush the green malt between rolls that thoroughly break up the cells of the acrospire. It is also desirable to sprout the grain to a more advanced stage than is done merely for the development of diastase.

At autopsy some guinea pigs showed impacted cecums, but this was only in case the animal died of scurvy and never if it was killed when the scurvy symptoms first appeared. We assume that the impacted cecum, as observed by McCollum and Pitz, is due to the fact that the guinea pig drinks little water during the last day or so of its life.³

CONCLUSIONS.

Acidosis has nothing to do with scurvy.

Sprouted cereal grains, especially after the acrospire projects $\frac{1}{2}$ inch beyond the grain, are rich in antiscorbutic substance (in this we merely extend the work of Fürst, and Cohen and Mendel).

The antiscorbutic substance in sprouted grain is not destroyed by heating to 70° to gelatinize the starch.

The antiscorbutic substance may be extracted from sprouted barley after crushing it between steel rolls that are so close together that the cells of the acrospire are crushed. In order to make the green malt feed between the rolls they must be geared to one another so as to turn at the same rate.

³ The keeper of the stock rabbits said he fed one rabbit in a separate cage exclusively on oats for 9 months. One of us at autopsy of this rabbit found no marked gross lesions except a fragility of the bones. One rib had broken spontaneously. Rabbits are much more resistant to scurvy than are guinea pigs.

BIBLIOGRAPHY.

- Brown, A. J., *Proc. Roy. Soc. London, Series B*, 1909, lxxxii, 82.
Bruntz, L., and Spillmann, L., *Compt. rend. Soc. biol.*, 1919, lxxxii, 8.
Chick, H., and Hume, M., *Tr. Soc. Trop. Med. and Hyg.*, 1917, x, 141.
Cohen, B., and Mendel, L. B., *J. Biol. Chem.*, 1918, xxxv, 425.
Duggar, B. M., and Davis, A. W., *Ann. Missouri Bot. Garden*, 1919, vi, 159.
Durand, J. I., *J. Am. Med. Assn.*, 1916, lxxvii, 564.
Fürst, V., *Z. Hyg. u. Infektionskrankh.*, 1912, lxxii, 121.
Greig, E. D. W., *Indian J. Med. Research*, 1916-17, iv, 818.
Holst, A., and Frölich, T., *J. Hyg.*, 1907, vii, 63.
McClendon, J. F., von Meysenbug, L., Engstrand, O. J., and King, F.,
J. Biol. Chem., 1919, xxxviii, 539.
McCollum, E. V., and Pitz, W., *J. Biol. Chem.*, 1917, xxxi, 229.
Palitzsch, S., *Compt. rend. trav. Lab. Carlsberg*, 1916, xi, 199.
Smith, A. H., *Lancet*, 1918, ii, 813.
Steenboek, H., Kent, H. E., and Gross, E. G., *J. Biol. Chem.*, 1918, xxxv, 61.
Van Slyke, D. D., Stillman, E., and Cullen, G. E., *J. Biol. Chem.*, 1919,
xxxviii, 167.
Weill, E., and Mouriquand, G., *Compt. rend. Soc. biol.*, 1917, lxxx, 33;
1918, lxxxii, 432, 607; *J. physiol. et path. gen.*, 1918, xvii, 849.
Wiltshire, H. W., *Lancet*, 1918, ii, 811.
Wright, A. E., *Army Med. Dep. Rep. 1895*, 1896, xxxvii, 394.

TOXICITY OF PHENYLACETIC ACID.

By CARL P. SHERWIN AND K. SELLERS KENNARD.

(From the Laboratory of Fordham University Medical School, New York City.)

(Received for publication, October 7, 1919.)

The retention of protein material in the intestine and its subsequent putrefaction leads to the formation and absorption of many protein decomposition products which are more or less harmful to the organism.

Phenylalanine on putrefaction yields three different aromatic acids, phenylpropionic acid, phenylacetic acid, and benzoic acid, while tyrosine undergoes analogous decomposition.

However, if phenylpropionic acid (1) is introduced into the gastrointestinal tract and absorbed, no phenylacetic acid is formed but it is subjected to the process of β -oxidation, loses two C atoms, and is changed directly into benzoic acid.

The benzoic acid combines with glycocoll and is excreted in the urine as hippuric acid. *p*-Hydroxyphenyl propionic acid (1) in a like manner is oxidized to *p*-hydroxybenzoic acid and is excreted as *p*-hydroxyhippuric acid. Phenylacetic acid resists oxidation and remains to be altered by combination with other compounds.

Salkowski (2) considered the acid relatively non-toxic and believed that it existed even in normal human urine as the free acid. This was perhaps because he had found only the combined acid in the urine of animals, such as dogs (2, 3), rabbits, and horses and was unable to isolate either the free or combined acid from human urine.

Huppert (4) fed phenylacetic acid to patients suffering from alkaptonuria and proved that the acid aided no way in the formation of homogentisic acid but was unable to find even a trace of the acid after feeding the patient a 10 gm. dose.

Hotter (5), who ingested the acid himself, could find neither the combined or uncombined acid in his urine, so concluded

that it was oxidized to benzoic acid and excreted as hippuric acid. Phenylacetic acid is particularly interesting from a physiological standpoint on account of its different metabolic action in the organism of man, animal, and fowl.

In the human body, the acid is combined with glutamine and excreted as phenylacetyl glutamine (6). This is the only case so far recorded where the amino-acid glutamine has been used by the body for the purpose of detoxicating a poisonous substance. Animals fed on phenylacetic acid detoxicate it by joining it with glycocoll and excreting it as phenaceturic acid (2).

After feeding the acid to a hen, Totani (7) isolated a compound from the excreta which he terms phenacetornithuric acid. This substance is a combination of one molecule of ornithine with two molecules of phenylacetic acid.

Phenylacetic acid, while found in only small amounts in the normal human body is one of the most important protein putrefaction products and is by no means as non-toxic as was previously supposed.

A hen weighing 2.23 kilos, after receiving 1 gm. of the acid, refused to eat. A second dose of 1 gm. 3 days later caused the hen to lose weight and develop marked signs of intoxication. A dog weighing 32.6 kilos was able to take 3 gm. of the acid with no apparent signs of discomfort; however, after receiving a dose of 7 gm. of the acid it became very thirsty, refused to eat, seemed to be greatly nauseated, and vomited several times.

A monkey of 4.2 kilos body weight, which received a dose of 1 gm. and refused to eat for several days, also developed a marked diarrhea. Twelve adult humans (male) after ingesting 5 gm. each of the acid showed in every case practically the same symptoms. The sodium salt of the acid was dissolved in 200 to 300 cc. of water and rapidly drunk. In 15 to 30 minutes after the ingestion of the acid, the subject became thirsty and this symptom was rapidly followed by a feeling of hunger. If food was ingested, symptoms of nausea developed; in case no food was taken, a feeling of dizziness resulted, followed either by drowsiness or increased nervousness. One subject weighing 59.1 kilos ingested as much as 16 gm. of the acid within a period of 2 hours. Within a few minutes, the usual sensation of dizziness and hunger developed, so the subject partook of an unusually heavy meal and went to bed.

1 hour after ingesting the last of the acid, he was unable even to stand unsupported. After sleeping soundly for 6 hours, he awoke and drank 1 liter of water, immediately fell asleep, and again slept soundly for nearly 8 hours. On waking he demanded water and drank more than $1\frac{1}{2}$ liters. He complained of nausea, headache, pain in the eyes, and of loud ringing in the ears. He was able to sit alone but seemed unable to stand unsupported or to correlate his movements. After another 4 hours of sleep, he appeared quite refreshed and normal in every way. In this case there was no sign of diarrhea but on the contrary he presented an obstinate case of constipation, which lasted for about 3 weeks.

In many respects the symptoms of poisoning by this acid resemble those of alcoholic poisoning.

EXPERIMENTAL.

In order to determine the toxicity of the acid, we decided to feed a small dog increasing doses of the substance and to determine if possible the minimum dose which would cause death and to study as carefully as possible any pathological changes produced by the acid.

A small dog of 7.5 kilos body weight was selected and placed in a metabolism cage for observation. The acid was fed to the dog as a water solution of the sodium salt by means of a stomach tube. On the 1st day of the experiment, he received 1 gm. of the acid. On each succeeding day, the dose of the acid was increased by 1 gm.

During the first 24 hours of the experiment following the 1 gm. dose of the acid, the dog showed no signs of discomfort but ate as usual and showed no signs of abnormal thirst. On the 2nd day after receiving the 2 gm. of the acid, the dog showed an abnormal appetite and drank often but only a small amount of water each time. On the 3rd day, he showed signs of drowsiness, but ate as much as usual and drank a large amount of water. On the 4th day, the dog refused to eat, spent most of the time in sleep, and seemed scarcely able to stand when removed from the cage. He was unable to walk and weighed at this time only 6.35 kilos. On the 6th day he still refused to eat and seemed to be in a semicomatose condition.

Up to this time there had been no signs of albumin in the urine but at this point a sufficient quantity was present to give a decided reaction. On the 7th day of the experiment, the dog appeared very weak and after receiving 7 gm. of the acid, underwent a series of convulsions during which time he vomited most of the acid. As much of this acid as possible was reclaimed and weighed. The total amount vomited was approximately 5.5 gm. so the dog received in fact only about 1.5 gm. of the phenylacetic acid on the 7th day.

For about 2½ hours after receiving this last dose of the acid, he appeared quite lifeless, then suddenly underwent a second series of convulsions, which ended in death.

Autopsy.—Performed about 6 hours after death. Male dog weighing 6.30 kilos. Gross examination of the organs presented no morphological lesions with the exception that the kidneys on section were congested and somewhat swollen, the cortex being pale; medulla congested, capsule non-adherent. Portions of liver, kidney, spleen, stomach, and alimentary canal were taken for microscopic examination. The specimens were fixed in Orth's fluid and mounted in paraffin. Sections were cut 6 microns in thickness and examined with ½ oil immersion, ocular 10.

Microscopic Examination.—The tunica fibrosa of the kidney does not appear to be thickened and the nuclear elements show no deficiency in staining qualities. The capillaries in the cortex corticis are engorged and the cellular elements within them appear disintegrated. While there is a general engorgement of the blood vessels, of the cortical portion of the organ, there is no extravasation of blood in the interstitial tissue.

The epithelium of the proximal convoluted tubules is much swollen and granular, so that the lumen of the tubule is in many places completely occluded by the approximation of the distal edge of the epithelial cells. Some of the tubules contain in their lumen the remains of broken down epithelial cells but this is in localities distinct from those in which the lumen is occluded and may indicate epithelial areas, which bore the effects of a greater toxic action of the drug. Blood elements are not seen within the tubules.

A glistening, hyaline material is found in the lumen of many of the tubules and in the cytoplasm of many cells the same material is seen. The engorgement of the capillaries between the tubules is marked. The degeneration of the epithelium is most marked in the proximal convoluted tubules in the neighborhood of the Malphigian corpuscles, becoming less marked as the descending loop is approached.

The arched collecting tubules are filled with the hyaline material and their epithelium, including the nuclei, is in many places destroyed. The epithelium of Bowman's capsule is likewise destroyed in many of the

renal corpuscles and while shrinkage of the glomerulus from the capsule is not present in every instance, yet it occurs in many of the corpuscles, particularly in those near the boundary zone of the medulla, and in the capsular space an exudate of hyaline and granular material and blood cells is present.

A round cell infiltration of the stroma of the glomerulus occurs and the capillaries of the tuft are engorged with blood.

In the medulla of the kidney, both limbs of Henle's loop show marked destructive changes of their epithelium. This in many places is totally disintegrated, so that the lumen of the tubules is filled with a mass of cellular remains and misplaced nuclei and a fine reticular mass, staining deeply with eosin, is present. Such epithelial cells as are not destroyed are detached in places from the wall of the tubules.

The epithelium of the straight collecting tubules does not appear affected by the action of the drug. All the cells are in place, the nuclei distinct, and the cytoplasm is clear. The nuclear membrane is distinct and the lumen of the tubule, for the most part, empty.

The interstitial tissue was not altered in appearance or amount.

The microscopic examination of the liver shows the cells to contain a number of globular refracted spaces, varying in size and in some instances occupying the greater part of the cell. The staining quality of many of the nuclei of the liver cells was markedly deficient. Unfortunately a section was not stained for fat.

The spleen was negative.

The stomach and intestines presented nothing of note.

SUMMARY.

The microscopic findings would seem to indicate that as a result of excessive doses of phenylacetic acid in the dog, the secreting epithelium of the proximal convoluted tube of the kidney is markedly affected; that the endothelium of the blood vessels is not affected; that the epithelium of the arched collecting tubule shows evidence of a destructive action, while that of the straight collecting tubule appears to escape.

The secreting epithelium of the limbs of Henle's loop is most distinctly involved; the fact that the interstitial tissue of the kidney is not injured and that the liver changes is in all probability secondary.

BIBLIOGRAPHY.

1. Schotten, C., *Z. physiol. Chem.*, 1882-83, vii, 27.
2. Salkowski, E., *Z. physiol. Chem.*, 1885, ix, 229.
3. Salkowski, E., *Ber. chem. Ges.*, 1884, xvii, 3010. Salkowski, E., and Salkowski, H., *ibid.*, 1879, xii, 653; *Z. physiol. Chem.*, 1882-83, vii, 161.
4. Huppert, Z. *physiol. Chem.*, 1897, xxiii, 412.
5. Hotter, E., *J. prakt. Chem.*, 1888, xxxviii, 97.
6. Thierfelder, H., and Sherwin, C. P., *Ber. chem. Ges.*, 1914, xlvii, 2630; *Z. physiol. Chem.*, 1915, xciv, 1.
7. Totani, G., *Z. physiol. Chem.*, 1910, lxxviii, 75.

THE CHEMICAL IDENTIFICATION OF THYROXIN.

SECOND PAPER.*

By E. C. KENDALL AND A. E. OSTERBERG.

(From the Section of Biochemistry, Mayo Foundation, Rochester, Minn.)

(Received for publication, September 15, 1919.)

Thyroxin is a white, highly crystalline substance, odorless, and tasteless. It may be separated from aqueous or alcoholic solutions in microscopic crystals which are not soluble in any organic solvent, except those which are strongly basic or acidic in nature. It is soluble in alcohol in the presence of mineral acid or an alkali metal hydroxide. It is stable toward heat, and its melting point is in the neighborhood of 250°C. Since it is odorless and colorless and is not easily affected by oxidation and reduction, its most important chemical and physical properties are concerned with the acidic and basic groups within the molecule. Thyroxin is a weak acid, but possesses basic properties in the presence of mineral acids.

In 1915, it was suggested that the organic nucleus in thyroxin is indole (1). Its solubility in alkali metal hydroxides, but not in carbonates, indicated that it was of phenolic nature, and its salt-forming power with acids was attributed to an imino group. After it was known that thyroxin contained about 60 per cent of iodine, and before the empirical and structural formulas were determined, the chemical properties of the molecule were best expressed by di-iodo-di-hydroxy-indole.

The first derivative of thyroxin, which helped to give an insight into its chemical structure, was the sulfate. Thyroxin which was precipitated from alkaline alcohol by acetic acid was found to contain 65 per cent of iodine. Thyroxin, precipitated by boiling an aqueous ammoniacal solution, also contained 65 per cent of iodine. Thyroxin, precipitated by adding sulfuric acid to an aqueous alkaline solution and boiling, was found to contain 60 per cent of iodine. The difference in iodine content was shown to be due to the formation of a salt with sulfuric acid, and by estimating the molecular weight of thyroxin from the molecular weight of

* First paper is published in *The Journal of Biological Chemistry*, 1919, xxxix, 125.

sulfuric acid, it was found to be 585. With hydrochloric acid substituted for sulfuric, an iodine content, slightly higher than theoretical, indicated that the hydrochloride was hydrolyzed to some extent. Thyroxin in free form precipitates as needles, but the hydrochloride separates in flat, rectangular, and star-shaped plates. Examination of the crystals of the hydrochloride, which contained more iodine than theoretical, showed both the free form and the



FIG. 1. The hydrochloride of thyroxin which separates in flat plates, rectangular, or star-shaped.

hydrochloride. The sulfate of thyroxin does not hydrolyze with water so readily as the hydrochloride (Figs. 1 and 2).

Ultimate analysis of thyroxin gave the percentages of carbon, hydrogen, oxygen, nitrogen, and iodine, and from these and the molecular weight determination of 586 the empirical formula was shown to be $C_{11}H_{16}O_3NI_2$. In constructing the structural formula we were guided by the following:

1. *Acidic Properties.*—Thyroxin is readily soluble in sodium, ammonium, and potassium hydroxide, and is insoluble in sodium, ammonium, and potassium carbonate as ordinarily tested. It is soluble in aqueous sodium and potassium carbonate, however, if very little carbonate is added and the solution boiled. It is precipitated by carbon dioxide from an alkaline solution. The empirical formula and these acidic properties, therefore, suggest the presence of one carboxyl group, which has very weak acidic properties, and a hydroxy group.

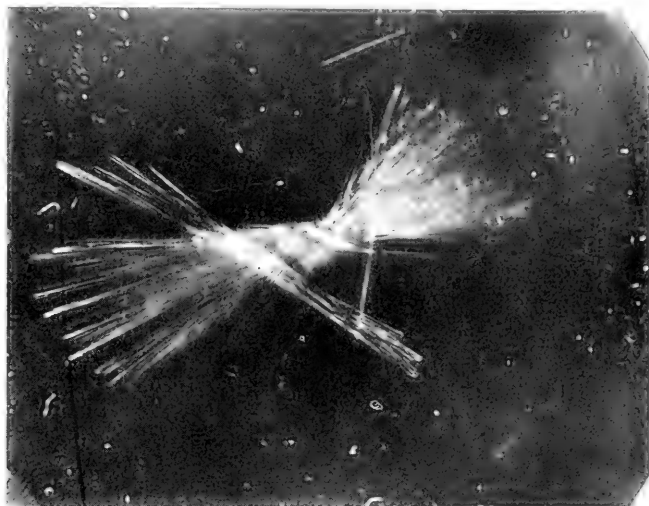
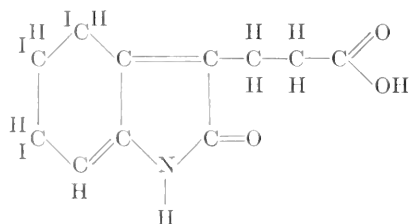

FIG. 2. The free form of thyroxin separated as a sheaf of needles.

2. *Basic Properties.*—Thyroxin forms salts with mineral acids, but not with weak organic acids. This, together with the fact that thyroxin forms a ureide with cyanic acid, is evidence for the presence of an imino group. The identification of the indole nucleus by the pine-splinter reaction after alkaline fusion was evidence that the imino group was present as in indole. Accepting the presence of the indole nucleus, there remained three extra carbon atoms, a carboxyl group, a hydroxy group, three atoms of iodine, and three extra hydrogen atoms, whose positions in the molecule were to be determined. Since tautomerism is common in the indole group, it seemed probable that the position of the

hydroxy group was adjacent to the imino, and that the three carbon atoms including the terminal carboxyl were attached to No. 3 position¹ of the indole nucleus. This structural formula, approximating that of tryptophane, satisfied all that was known concerning the chemical properties of the molecule except the position of the three iodine atoms and the three extra hydrogen atoms. As no special difference was demonstrable between the reactivity of the three atoms of iodine, it seemed most probable that they were all attached to the benzene ring, and as three extra hydrogen atoms would be required, if the iodine was added to, and not substituted for, hydrogen on the ring, they also were placed on the benzene ring. This formula is a tetra-hydro derivative of indole, the three atoms of iodine being substituted for three of hydrogen on the reduced benzene ring.



4, 5, 6 tri-hydro-4, 5, 6 tri-iodo,-2 oxy,-beta indolepropionic acid.

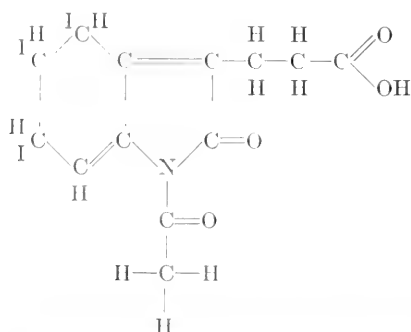

¹ In this paper the positions in the indole nucleus will be referred to as follows.



In proving the formula the first derivatives were those involving the imino group. By the addition of acetic anhydride to a slightly alkaline, alcoholic solution of thyroxin, the hydrogen of the imino is replaced with acetyl and the acetyl derivative may be separated in crystalline form by the addition of sulfuric acid and water and the removal of the alcohol by boiling under

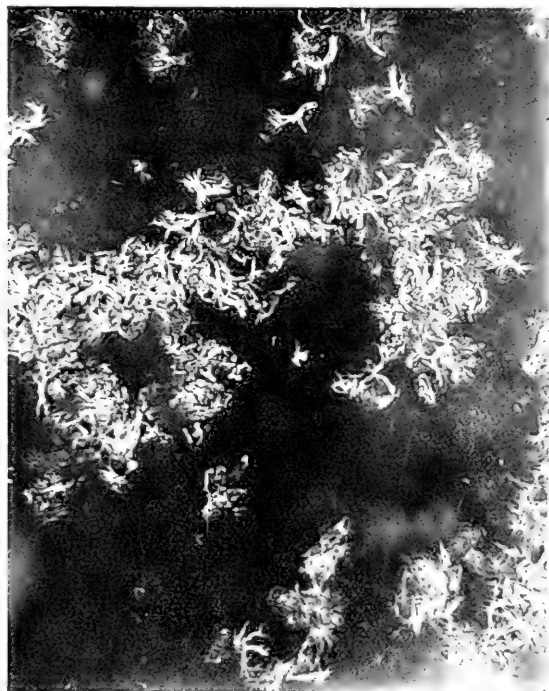

FIG. 3. The crystal form of the acetyl derivative of thyroxin.

diminished pressure. The sulfate of the acetyl of thyroxin is thus formed. This is dissolved in a small amount of alcohol and when added to boiling water the acetyl of thyroxin separates in pure form (Fig. 3). The melting point of the acetyl is slightly lower than that of thyroxin, it crystallizes in the form of needles more curved and much shorter than those of thyroxin, and although thyroxin is insoluble in all organic solvents the acetyl is readily

270 The Chemical Identification of Thyroxin

soluble in alcohol, ether, ethyl-acetate, and dilute aqueous ammonia and pyridine. The close approximation, by analysis, of the theoretical percentage of iodine in the acetyl, 60.77, corroborates the molecular weight of 585.

Another derivative of the imino group which is easily formed is the ureide.

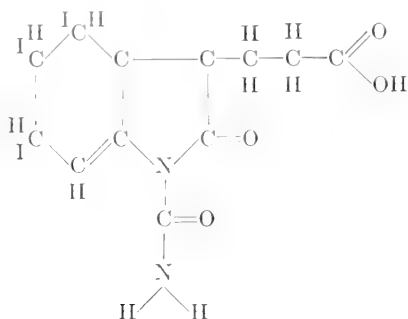

This is made by the addition of a salt of thyroxin, either the sodium or zinc salt, to acetic acid to which potassium cyanate has already been added. Cyanic acid reacts with thyroxin with the formation of the ureide. It separates from boiling water in curved needle form and has very closely the same solubilities as the acetyl (Fig. 4). Analysis of the ureide shows the percentage of iodine to agree with the theoretical, 60.67. This is a third confirmation of the molecular weight 585. Although thyroxin forms a stable salt with sulfuric acid which is not hydrolyzed by boiling in dilute sulfuric acid, the addition of the acetyl or ureide groups to the imino increases the acidic properties of the imino, and these derivatives do not form stable salts with sulfuric acid except at low temperatures. Boiling the sulfate in dilute sulfuric acid causes a complete hydrolysis and separation of the acetyl or ureide in free form. The presence of the imino group in thyroxin is established by identification of the indole nucleus, the formation of the acetyl and ureide derivatives, and by the power to form salts with mineral acids.

The evidence for the carboxyl and hydroxy groups is as follows: Thyroxin is extremely insoluble in aqueous solutions of all acids, including carbonic. It is very easily soluble in sodium potassium and ammonium hydroxide, but the weakness of the acidic groups

on the molecule is shown by the fact that boiling water alone causes a complete hydrolysis of the ammonium salt and free thyroxin may be precipitated in crystalline form by boiling an aqueous or alcoholic solution of its ammonium salt. Dilute solutions of sodium and potassium carbonate will dissolve only a small amount of thyroxin in the cold, but it is soluble in very dilute solutions of

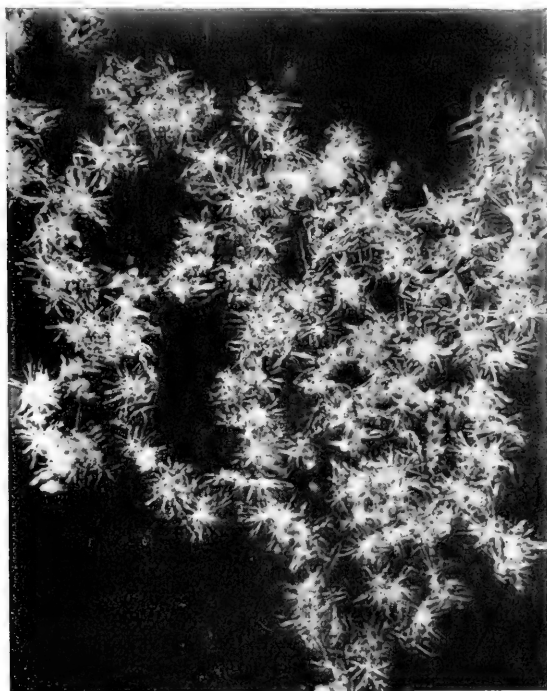

FIG. 4. The crystal form of the ureide derivative of thyroxin.

sodium and potassium carbonate at 100°C. However, on cooling such a solution, a mono-metal salt of thyroxin separates in crystalline form. If an excess of carbonate is present at first, the mono-salt of thyroxin is so insoluble in the presence of the excess sodium or potassium carbonate that most of the thyroxin being tested remains insoluble. The addition of a very slight amount of sodium or potassium hydroxide to a solution containing a

suspension of thyroxin in the presence of sodium or potassium carbonate immediately carries the thyroxin into solution. These reactions suggest that there are present in thyroxin both carboxyl and hydroxy groups. The carboxyl group reacts with carbonates but the resulting mono-salt is so slightly soluble that the presence of excess carbonate forces the mono-salt out of solution. The hydroxy group in the presence of carbonates alone does not react, but the addition of hydroxide to such a solution forms a metal salt with the hydroxy group, and the di-metal salt is readily soluble.

Still further evidence for this action is found in the barium salt. Barium chloride added to a sodium hydroxide solution of thyroxin precipitates thyroxin in needle crystals, usually twined, or in sheaves or bundles. If this is filtered off it is found to be slightly soluble in boiling water. On cooling and with the addition of a soluble barium salt to the solution, the barium salt of thyroxin recrystallizes quantitatively. If red litmus paper is dipped into a boiling aqueous suspension of the barium salt, the solution reacts neutral, but wherever the crystals of the barium salt come in contact with the paper the color of the indicator is changed to blue, showing that hydrolysis of the barium salt has occurred. If sodium hydroxide is added to an aqueous suspension of the barium salt of thyroxin the barium salt is dissolved and becomes almost as soluble as the sodium salt. This behavior is explained by the fact that the second hydroxyl group of barium hydroxide is not sufficiently strong to form a soluble salt with the hydroxy group of thyroxin. In the presence of boiling water the hydroxy group of thyroxin and one hydroxy group of barium exist in free form, barium forming a salt only with the carboxyl group in thyroxin. Both hydroxy and carboxyl groups are slowly hydrolyzed by prolonged boiling of the barium salt in water.

The difference between the two acid groups is also shown in a sodium potassium, or ammonium hydroxide solution of thyroxin. If carbon dioxide is bubbled through such a solution so as to produce sodium carbonate, but not bicarbonate, the hydroxy group is freed from metal and the mono-metal salt of thyroxin separates in flat crystals, oval, rectangular, or square. If an excess of carbon dioxide is passed through the solution, the carboxyl group also is freed and thyroxin will separate. The sepa-

ration of the monosodium salt occurs at the point where the hydroxy group has been freed, but the carboxyl group is still in the form of a salt (Figs. 5 and 6).

While endeavoring to separate the metal salts for analysis the monosodium, potassium, and ammonium salts of thyroxin were prepared by dissolving thyroxin in strong solutions of the hydroxides and passing carbon dioxide through these until the



FIG. 5. The monopotassium salt of thyroxin which separates in small flat plates, rectangular, or square.

mono-metal salt separated. The crystals were filtered on a small Buchner funnel, and washed with water. It was found that approximately 60 per cent of the amount of thyroxin taken was left on the funnel after drying in the supposed form of the monosodium, potassium, and ammonium salts. It was also found that if the salt was washed on the funnel with a 20 per cent solution of

sodium or potassium chloride, and not with water, the compound did not melt. When, however, the mono-salt was washed with water the sodium, potassium, and ammonium salts all had the same melting point, 204° . Since the mono-salt of thyroxin does not melt and the sodium, potassium, and ammonium salts, washed with water, all melt at exactly the same point, it seemed probable



FIG. 6. The monoammonium salt of thyroxin which separates in long blades.

that the washing with water was sufficient to hydrolyze the very weak carboxyl, with the result that free thyroxin was left on the paper, the base being entirely washed away. In order to determine this the monoammonium salt was prepared as above, filtered, and washed with water and then analyzed for ammonia by means of Nesslerization. Nesslerization, although an exceedingly sensitive test for ammonia, failed to show the presence of even the

faintest trace of ammonia in the supposed monoammonium salt of thyroxin. It was therefore evident that by washing the mono-sodium, ammonium, and potassium salts of thyroxin with water the weak carboxyl group can be completely hydrolyzed, and since the hydroxy group already was in the free form, the molecule existed with both carboxyl and hydroxy groups uncombined with metal.



FIG. 7. The disilver salt of thyroxin which separates in large, flat, rectangular and square plates, often occurring in sheaf form and twined.

Evidence that a di-metal derivative of thyroxin does form is furnished by the silver salt. Although a disilver salt containing the theoretical amount of iodine has not been prepared, this salt has been made with so much silver present that it amounted to 92 per cent of the theoretical for the addition of two atoms of silver to the molecule. The reason why the theoretical disilver salt

cannot be prepared is undoubtedly due to the weakness of the hydroxy group (Fig. 7). When the disilver salt, which is highly crystalline, is washed in order to remove the excess of silver nitrate and ammonia which are used in its formation, the hydroxy group hydrolyzes to some extent, and the amount of silver remaining is slightly less than theoretical.



FIG. 8. The dipotassium salt of thyroxin which separates in flat plates with rough, irregular edges.

[Di-basic salts of sodium, ammonium, and potassium are formed by dissolving thyroxin in the respective hydroxides, and adding a corresponding salt of the alkali preferably the chloride until the di-alkali salt of thyroxin becomes insoluble and precipitates in crystal form (Fig. 8). Di-basic salts, which are only slightly soluble, have also been prepared with barium, calcium, magnesium, nickel, zinc,

and copper (Fig. 9). Although all these salts may be made in beautifully crystalline and characteristic form, it is impossible to filter and separate them in a high state of purity by washing with water. Just as hydrolysis of the hydroxy group caused a lower silver content than theoretical with the silver salt, the hydrolysis of the hydroxy group with the barium salt shows a lower percentage

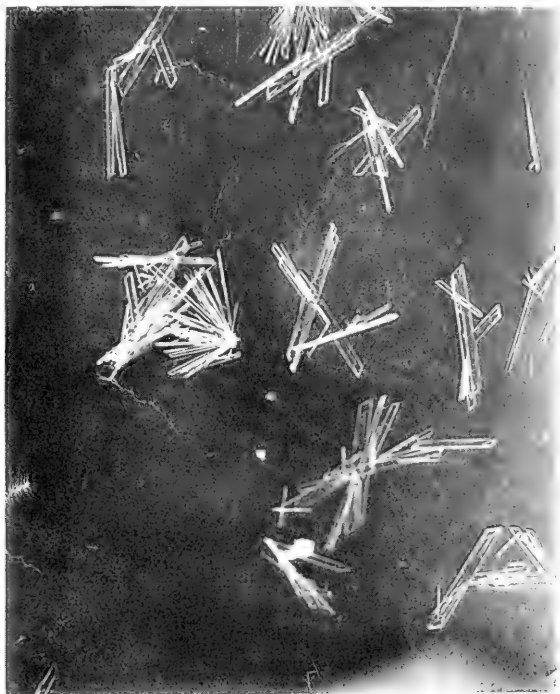

FIG. 9. The zinc salt of thyroxine which separates as long, flat blades in bundles and rosettes.

of iodine than theoretical. However, the weight of barium added is about twice that required for the mono-metal salt. With the less basic properties of calcium, magnesium, zinc, nickel, and copper, even greater differences occur between the amount calculated for a di-metal salt and the amount found. But in every case since the amount of metal present nearly agreed with that required

for a di-basic salt, the possibility that these are mono-basic salts is excluded. All salts of thyroxin which are insoluble in water such as the silver, copper, zinc, nickel, calcium, and magnesium are soluble in sodium hydroxide. The solubility is probably due to the same reactions that occur with the barium salt. The weak basic properties of the metals are insufficient to form soluble di-basic salts, but sodium hydroxide carries the salt into solution by adding to the hydroxy group of thyroxin.

Other evidence for the carboxyl and hydroxy groups is furnished by the dimethyl ester. Methyl iodide added to an alcoholic suspension of the silver salt forms the dimethyl ester. This is soluble in alcohol but insoluble in water even in the presence of sodium hydroxide. By heating in dilute alcoholic sodium hydroxide, hydrolysis of the methyl ester of the carboxyl occurs and the oxymethyl derivative is obtained.

Tautomeric Forms of Thyroxin.

Thyroxin reacts in the presence of alkalis forming dibasic salts, but differences between the two acidic groups indicate that one is a carboxyl and one a hydroxy group. When thyroxin exists in this form, which will be called the enol, the hydroxy group is adjacent to the nitrogen but there is a double-bond between the nitrogen and the alpha carbon, and no hydrogen is attached to the nitrogen.

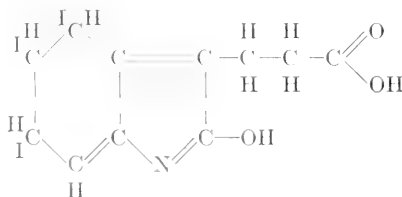

In acid solution thyroxin forms derivatives which demonstrate the presence of an imino group and exists in its tautomeric form, with imino carbonyl groups adjacent. This will be called the keto form. When thyroxin was first isolated it was in the keto form and although it seemed probable that the hydrogen migrated in alkaline solution with a change from carbonyl to hydroxy groups, no quantitative data were available for proof of the hypothesis.

When the mono-metal salts of sodium, ammonium, and potassium were prepared by freeing the hydroxy group in alkaline solution with carbon dioxide, it was found that by washing with water complete hydrolysis of the carboxyl also occurred. When the hydrolysis of the ammonium salt was carried out at 100° both acidic groups were not only freed but, in addition, the boiling water caused



FIG. 10. The crystals of the enol form of thyroxine.

a change from the enol to the keto form. However, if the mono-metal salts are hydrolyzed with cold water the enol form is retained. There are many differences in the chemical properties of the enol and keto forms, but the most striking difference is in the melting point. The melting point of the enol form is 204°, that of the keto, 250°.

When the enol form of thyroxine was prepared by cold hydrolysis of its ammonium salt, it still retained the crystal form of this salt,

but by dissolving the crystals in pyridine and adding water the enol form separated in its own characteristic crystal form (Fig. 10). The enol form of thyroxin separates in needle crystals which are much shorter than those of the keto form and always occur in rosettes or sheaf-like bundles. Crystallization does not alter the melting point.



FIG. 11. The simultaneous crystallization of both enol and keto forms of thyroxin from an aqueous pyridine solution.

The keto form of thyroxin is by far the more stable and, unless precautions are observed, the enol form readily passes over into the keto. The most important factors influencing the change from enol to keto form are the presence of water and the hydrogen ion concentration. By adding water to a pyridine solution of the enol form, conditions may be produced in which both enol and keto forms simultaneously crystallize (Fig. 11). On long standing even

at room temperature, the enol form slowly changes over to the keto and the keto form alone separates. Since the chief chemical properties of thyroxin are due to its basic and acidic groups, a brief summary of solubilities and reactions of the two tautomeric forms is of interest.

The enol form of thyroxin is much more soluble than the keto, and the solubility may be used as a test of the form in which thyroxin is present. For example, the keto form is insoluble in all organic solvents, such as all alcohols, ether, chloroform, ethyl acetate, acetone, carbon disulfide, quinoline, pyridine, anhydrous or aqueous, and aniline. The enol form is readily soluble in anhydrous or aqueous pyridine. Therefore, pyridine alone is not sufficiently basic to change the keto into the enol form, but when this change has been produced pyridine readily dissolves thyroxin. Since ammonium hydroxide in water, alcohol, or pyridine will change the keto form to the enol, but pyridine cannot produce this change, the hydroxyl ion concentration necessary for the conversion from one tautomeric form to the other lies between the basicity of dilute ammonium hydroxide and that of pyridine. Since the enol changes to the keto in a boiling aqueous pyridine solution, the acidity necessary for the tautomeric change in this direction lies between the narrow limits of the hydrogen ion concentration of a cold and a boiling aqueous solution of pyridine. The limits for the change in tautomeric form are at the same time the limits of solubility for thyroxin in alkaline solution. Thyroxin is soluble in enol form, in pyridine and quinoline, but any higher concentration of hydrogen ion causes the change to the keto form and limits the solubility of thyroxin in alkalies. Thyroxin in the keto form remains insoluble in all organic solvents with hydrogen ion concentrations equal to or less than that of glacial acetic acid. It is soluble in formic acid, but the subsequent addition of water causes thyroxin to separate again. Although acetic acid will not make thyroxin soluble in alcohol the addition of a mineral acid renders thyroxin readily soluble in alcohol. Solubility under these conditions is evidence for the formation of salts with the imino group.

The acid and basic properties of thyroxin therefore lie between these two limits: (1) The formation of salts with acids through the imino group of the keto form with formic acid, but not acetic;

and (2) the formation of salts with alkalies through both the carboxyl and hydroxy groups with dilute ammonia, but not with pyridine. Lying between these two limits are the formation of mono-metal salts through the carboxyl alone in the presence of carbonates but not bicarbonates, and finally the complete precipitation of thyroxin from the alkali metal salts by carbonic acid or by hydrolysis with water in a boiling ammoniacal solution. The mono-metal salts of thyroxin are but slightly soluble in water but are easily soluble in alcohol. The solubility in alcohol is due to the fact that although only the carboxyl group is combined with metal, the molecule is in the enol and not the keto form.

The imino group of thyroxin reacts with all acids stronger than and including formic acid, but no acid salt of thyroxin is appreciably soluble in water, and even the sulfate which is the most soluble is only very slightly so. The great insolubility of the keto form of thyroxin is one of the most important factors permitting the isolation of the compound. The insolubility of thyroxin is also of importance in a consideration of its chemical properties. As soon as the proper conditions exist in any solution for the formation of the keto form of thyroxin, the reactive groups are thrown almost completely out of the sphere of reaction by the insolubility of the compound.

The keto form of thyroxin is soluble in organic solvents only when some acid is present which is capable of forming an acid salt with the imino group. Thyroxin may be conveniently purified by dissolving either in alkaline alcohol with the addition of acetic acid, or by dissolving in acid alcohol with the addition of sodium acetate. In the presence of acetic acid the imino group does not form a salt and thyroxin precipitates in needle form.

Open-Ring Form of Thyroxin.

Since thyroxin in keto form is insoluble in bases weaker than ammonium hydroxide and is insoluble in alcohol in the presence of acids weaker than formic, there is a wide range of hydrogen ion concentration in which pure thyroxin is insoluble. These limits of solubility, however, apply only to pure thyroxin in aqueous and alcoholic solutions. In the presence of certain substances, changes in the acid and basic groups occur and the solubilities of

thyroxin are materially altered and extended. In the presence of the products resulting from alkaline hydrolysis of the thyroid proteins the solubility of thyroxin is so greatly altered that it is completely soluble in carbonic acid, and even acetic acid produces an incomplete precipitation. Hydrochloric and sulfuric acids precipitate thyroxin under these conditions, but in excess they redissolve a considerable percentage of the total amount present. The increased solubility in acids indicates an increase in the strength of the basic groups of the thyroxin molecule. Although pure thyroxin is practically insoluble in pyridine, sodium carbonate, barium hydroxide, and alcohol, partially purified thyroxin is readily soluble in the presence of all these reagents. The increased solubility in weak alkalies indicates an increase in the strength of the acidic groups in the thyroxin molecule. These changes in the chemical properties of thyroxin are most marked during the early stages of purification while there is a large percentage of impurities present, but that the alteration is due entirely to the impurities is disproved by the fact that both increased acidic and basic properties persist even after the removal of all but a trace of the impurities. Furthermore, the addition of certain substances to a solution of pure thyroxin brings about a similar increase in both basic and acidic properties. The solubility of partially purified thyroxin in weak alkalies is in such striking contrast to the solubility of pure thyroxin that it cannot be explained except by a change in the structure of the molecule other than the two tautomeric forms described above. The exact nature of this change was suggested by a study of the acetyl.

In all derivatives of thyroxin involving the hydrogen of the imino group, it is impossible to make the enol form, as the hydroxy group cannot exist. Because of the absence of the hydroxy group these derivatives should form mono-basic salts through the carboxyl group alone, they should be more insoluble in alkalies, and should form insoluble barium and silver salts. Since acid salts of the imino are soluble in alcohol, acetic acid, and ethyl acetate, it seemed probable that derivatives attached to the imino would also make the molecule soluble in these reagents. After the acetyl and ureide were prepared in pure form they were found to be easily soluble in alcohol, acetic acid, and ethyl acetate, but instead of being less soluble in alkalies, the acetyl was more soluble and could be held in solution with as weak a base as pyridine alone.

284 The Chemical Identification of Thyroxin

The acetyl was not only more soluble in weak organic bases but it also formed a silver salt which was completely soluble in dilute ammonium hydroxide. The silver salt of thyroxin will separate from strong ammonium hydroxide, but the silver salt of the acetyl is so soluble that it is impossible to prepare it in the presence of ammonia. By dissolving the acetyl in pyridine, however, the addition of silver nitrate produces a voluminous precipitate which may be washed, dried, and analyzed. When this was done it was found that the acetyl had formed a di-basic salt with silver. The formation of a di-basic salt by the acetyl indicated the presence within the molecule of another acidic group other than the terminal carboxyl. The simplest change by which a carboxyl group could be formed would be by introduction of a molecule of water between the imino and carbonyl groups, changing the imino carbonyl groups to amino carboxyl groups, and in the case of the acetyl the amino group is combined with one acetyl radical.

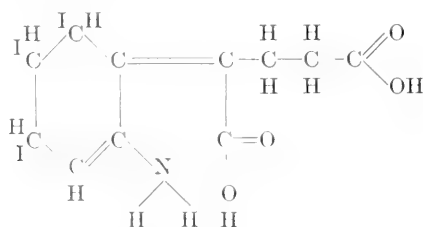

The presence of the acetyl radical in place of the imino hydrogen prevents the tautomeric change to the enol form, but in place of this, the ring opens even in the presence of weak organic bases. The acetyl attached to the amino group, however, does not prevent the closure of the ring, and if an alkaline solution of the acetyl, which is present in the open-ring form, is added to a dilute mineral acid at 100°, the ring closes and the acetyl separates in crystalline form. In addition to the disilver salt of the acetyl, the zinc salt has been made, and di-basic sodium, ammonium, and potassium salts of the open-ring form of the acetyl may be prepared by dissolving in the respective hydroxides and adding a corresponding salt, the chloride or acetate, until the salt of the acetyl becomes insoluble (Figs. 12 to 15). If sodium hydroxide and sodium acetate are used, very large, flat, jagged plates result;

with sodium hydroxide and sodium chloride short needle crystals are formed.

Barium and calcium salts of the acetyl can also be formed by the addition of barium or calcium chloride to a solution of the acetyl in dilute sodium hydroxide or pyridine. An excess of pyridine dissolves the salt.



FIG. 12. The disodium salt of the acetyl derivative separated from a sodium chloride solution.

After the physical and chemical properties of the acetyl derivative had been established, it was found that a most striking resemblance existed between partially purified thyroxin and the acetyl. The acetyl differs from thyroxin in having wider limits of solubility in weak bases, and the greatest difference between partially purified and pure thyroxin is the solubility of the former in weaker alkalies as sodium carbonate, barium hydroxide, pyridine,

and in alcohol. These reactions suggested that in partially purified thyroxin the structure of the molecule is similar to that of the acetyl. But the possibility that an acid radical was attached to the imino group, as in the acetyl, could be excluded by the fact that the thyroxin could be separated in keto form. The increase in both acidic and basic properties, its close resemblance in chemical

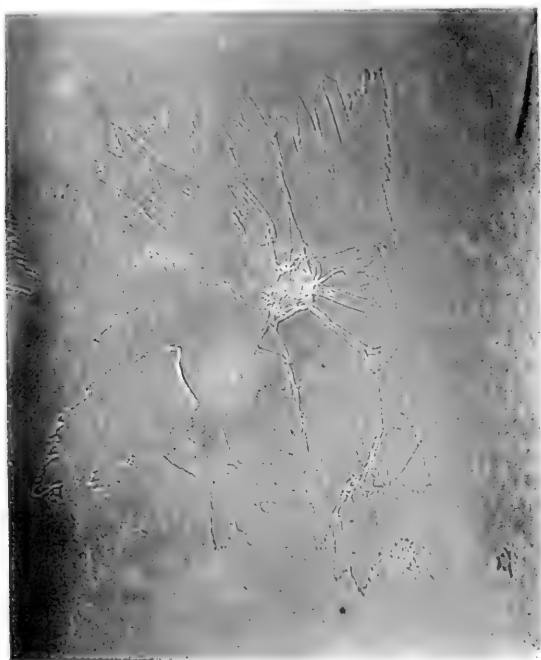

FIG. 13. The disodium salt of the acetyl derivative separated from a sodium acetate solution.

reactions to the acetyl, and the fact that it could be separated in the keto form suggest that in partially purified thyroxin the molecule is present neither in the keto nor enol forms, but that the pyrrole ring exists in open form, the elements of water entering between the carbonyl and imino groups.

This structure of the molecule of thyroxin will be called the open-ring form. The open-ring form of indole derivatives con-

taining an alpha carbonyl group is of common occurrence, but thyroxin is perhaps unique in the great ease with which the ring opens and the great difficulty with which the ring closes in the presence of certain substances.

Although the open-ring structure of thyroxin was first suggested by a study of the acetyl, further investigation has amply confirmed this hypothesis, and brought to light the delicately balanced



FIG. 14. The dipotassium salt of the acetyl derivative.

reactions, which, in all probability, are involved when the substance functions physiologically. These reactions are concerned with the opening and closing of the ring and the formation of salts with acids by the amino and imino groups. When sulfuric acid is added to a slightly alkaline alcoholic solution of thyroxin and the alcohol is distilled, the sulfate of thyroxin separates, the sulfate radical being attached to the imino group. However,

if sulfuric acid is added to an alkaline aqueous solution of thyroxin, the resulting precipitate is not the imino sulfate of thyroxin. Analysis of this precipitate for its iodine content showed that thyroxin had not precipitated in free form but contained one equivalent of acid. Further investigation showed that thyroxin precipitates with one equivalent of acid, not only with sulfuric



FIG. 15. The dipotassium salt of the ureide of thyroxin which separates in a manner similar to the dipotassium salt of the acetyl derivative.

but with weak organic acids and that even carbonic acid adds to thyroxin when carbon dioxide is passed through an alkaline solution. The sulfate, chloride, phosphate, trichloracetate, oxalate, formate, acetate, and carbonate of thyroxin have been prepared. All these salts are soluble in alcohol and have melting points which are strangely similar, all of them melting at about 204° . Although the imino group of thyroxin in keto form is so feebly

basic that in hot dilute hydrochloric solution the acid radical is hydrolyzed and the imino group exists in free form, when the enol form of thyroxin is precipitated by an acid, an equivalent of acid is contained in the precipitate attached to thyroxin. If any of these salts, prepared by acidifying an alkaline solution of thyroxin, are removed from solution, suspended in distilled water, and boiled, a change occurs, and thyroxin

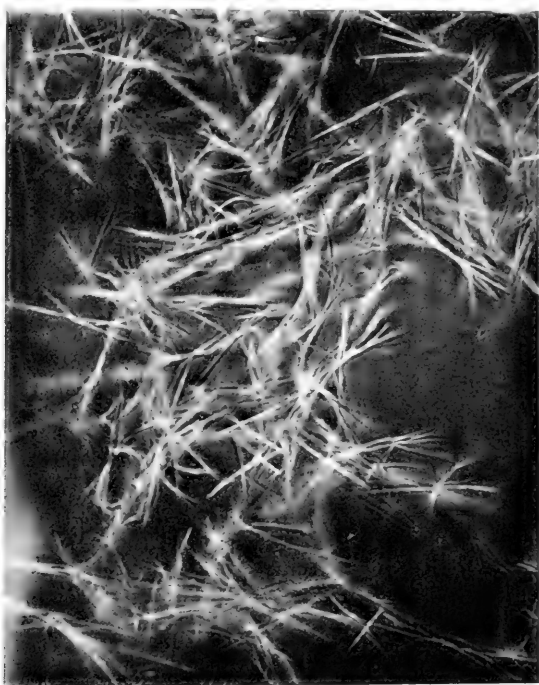
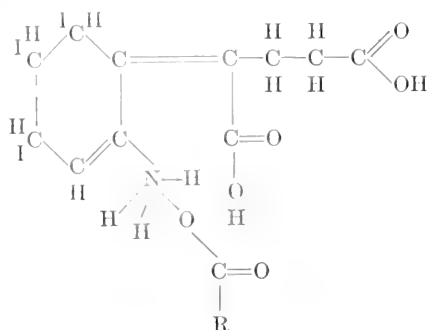

FIG. 16. Crystals of thyroxin in the amino carboxyl form.

precipitates in long, bundle blades. These blades differ from the keto form of thyroxin in being soluble in alcohol and having a melting point of 225° . If instead of suspending the acid salts in distilled water, they are added to a dilute solution of hydrochloric or sulfuric acid and are then boiled, the keto form of thyroxin separates. These reactions are interpreted as follows:

When an acid is added to the enol form of thyroxin, the nitrogen becomes pentad and the acid radical adds to the nitrogen. In

aqueous solution the pyrrole ring is no longer stable and the elements of water add between the pentad nitrogen and the carbonyl group forming a carboxyl group and an acid salt of the amino group.



In cold water solution this reaction occurs not only with sulfuric and strong organic acids, such as trichloroacetic and oxalic but even carbonic acid is capable of adding to the amino group. When the amino salt is suspended in distilled water and boiled, the amino group is hydrolyzed free from the acid, and the carboxyl group which is adjacent to the amino group forms a salt with the amino group. The compound then exists in an amino carboxyl salt form, the acid used in precipitating thyroxin having been expelled from the amino group by hydrolysis with water.

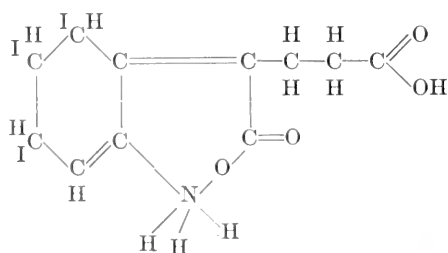

This form of thyroxin differs from both the keto and enol forms in having the addition of the elements of water. It has a melting point of 225° and is soluble in alcohol (Fig. 16). It is converted into the keto form very easily, merely solution in alcohol

is sufficient to expel the water, and the keto form of thyroxin then separates. It is impossible to separate the amino carboxyl salt form of thyroxin from solutions containing a high percentage of alcohol. Further investigation showed that this is also true of pyridine and other organic solvents. It is necessary to have water present in order to force the opening of the pyrrole ring.

If any acid salt of the amino group of the open-ring form of thyroxin is suspended in distilled water and boiled, the carboxyl



FIG. 17. Crystals of the amino carbonate of thyroxin.

group in thyroxin, which is adjacent to the amino, will displace the acid radical attached to the amino, and the amino carboxyl salt form of thyroxin results. If the acid radical which is added to the amino is sufficiently strong and an excess of the acid is present, the ring does not remain open, but the elements of water are expelled and the strong acid radical is either hydrolyzed from the imino group or remains attached as an acid salt of the imino group. The closing of the ring of an amino-acid salt is influenced by many factors, such as the amount of acid present, the strength of the acid, and the presence of organic solvents, such as pyridine

or alcohol. Strong acids promptly close the ring, forming imino salts; weak acids are expelled from the amino, and the molecule exists in the amino carboxyl form. The presence of organic solvents such as alcohol results in the closing of the ring and the formation of imino salts with strong acids, or the displacement of the acid with the separation of thyroxin in keto form. If an



FIG. 18. A mixture of the crystals of the amino formate changing into the amino carboxyl salt form of thyroxin. The long needles are the amino carboxyl crystals.

amino-acid salt of the open-ring form is washed free from all acid, suspended in neutral water, and boiled, the acid is promptly hydrolyzed from the amino group and the amino carboxyl salt form results, but in the absence of excess acid in solution this form of thyroxin is unstable at 100°C ., water is rapidly expelled from the ring, and the keto form of thyroxin separates in very

fine, thread-like crystals. Under proper conditions all three forms may be present at the same time (Figs. 17 to 19).

Since acids added to the enol form of thyroxin in aqueous solution cause an opening of the ring, the question arose as to whether the opening of the pyrrole ring is the primary action, or whether it is secondary to the existence of the nitrogen in the pentad form. That the opening of the ring occurs without passing

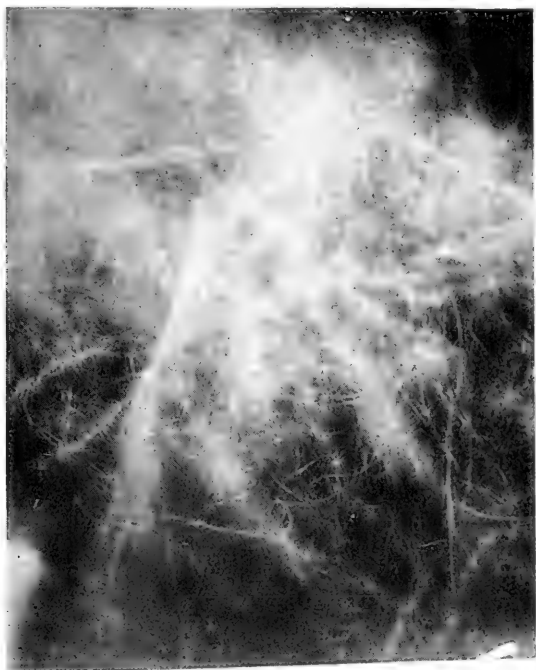

FIG. 19. A mixture of amino carboxyl crystals changing into the keto form of thyroxin. The long needles are crystals of the amino carboxyl form of thyroxin.

through the enol form is shown by the formation of the amino sulfate directly from the imino sulfate (Figs. 20 and 21). When the imino sulfate is present in a small amount of alcohol and water is added, the ring opens and the amino sulfate separates even though the molecule had existed in the keto form. The formation of amino salts from imino salts shows that the ring opens

readily when the nitrogen is in the pentad state, but that the opening of the ring also occurs directly from the enol form in a solution slightly alkaline may also be shown. When the disodium salt of thyroxin is dissolved in cold water and ammonium chloride is added to the solution, the sodium is hydrolyzed from hydroxy and carboxyl groups, resulting in the precipitation of thyroxin in the enol form. If this suspension of the enol form is now boiled



FIG. 20. The imino sulfate of thyroxin separated from a hot solution.

the crystal form changes into the typical amino carboxyl salt form, the melting point of which is 225° . The crystals are also readily soluble in alcohol which excludes the possibility of their being in the keto form. A more direct evidence of the existence of thyroxin in open-ring form is obtained by dissolving the disodium salt in hot water and adding ammonium chloride to this hot solution. Instead of thyroxin separating in the enol form, it

separates directly as the amino carboxyl salt form. The most important factor in this reaction is the presence of excess alkali. If much alkali is present, the molecule exists in the enol form and addition of ammonium chloride will cause a separation of the monoammonium salt.

From these results it would appear that in acid alcohol solutions thyroxin exists in the keto form. In the presence of excess alkali

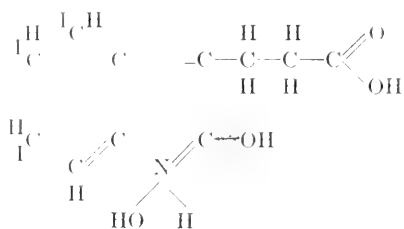

Fig. 21. The amino sulfate of thyroxin formed from the imino sulfate of thyroxin by the addition of water to an alcoholic solution of imino sulfate.

in aqueous solution thyroxin exists in the enol form, but as the neutral point is reached from either direction there is a tendency for the ring to open. In a hot neutral solution the ring does open. In a cold neutral solution even carbonic acid will open the ring and add to the amino group.

The Amino Hydrate Form of Thyroxin.

The pyrrole ring of thyroxin not only has a tendency to take up water between the imino and carbonyl groups and exist in amino carboxyl form, but the amino group is so strongly basic that in a slightly alkaline solution the elements of water will add to the nitrogen forming the amino hydrate.



This form of thyroxin is tautomeric with the amino carboxyl form. It is very readily prepared by heating an alkaline solution of thyroxin, removing the solution from the flame, and adding 10 per cent ammonium chloride. The solution becomes turbid, and fine branching crystals separate (Fig. 22). The melting point of this form of thyroxin is 216°. If these crystals are suspended in distilled water containing a small amount of formic acid and the solution is boiled, the crystals are changed into their tautomeric amino carboxyl form, whose melting point is 225° (Figs. 23 and 24).

One form of thyroxin changes into another so easily that enol and keto forms will crystallize simultaneously out of the same solution, and amino-acid salt, amino carboxyl salt, and keto forms may all be present at the same time, one form changing into another as the boiling of the solution is continued. The ready change of thyroxin from one form to another is explained by the great ease with which the pyrrole ring opens and the elements of water are added to the molecule. This reaction does not occur with indole or isatin and was not at first easily explained in the case of thyroxin. While engaged in the preparation of the intermediate products for the synthesis of thyroxin, our attention was drawn to the fact that the explanation of the peculiar properties of the imino group in the pyrrole ring of thyroxin is the presence

of the hydro groups in the benzene ring. Aniline is a feeble base and the imino group in indole is still more feebly basic. Hexahydro-aniline has such a strongly basic amino group that it will combine with carbon dioxide from the air, and it has a very caustic action on the skin. It is the addition, therefore, of four hydro groups to the molecule that so modifies the nucleus giving basic

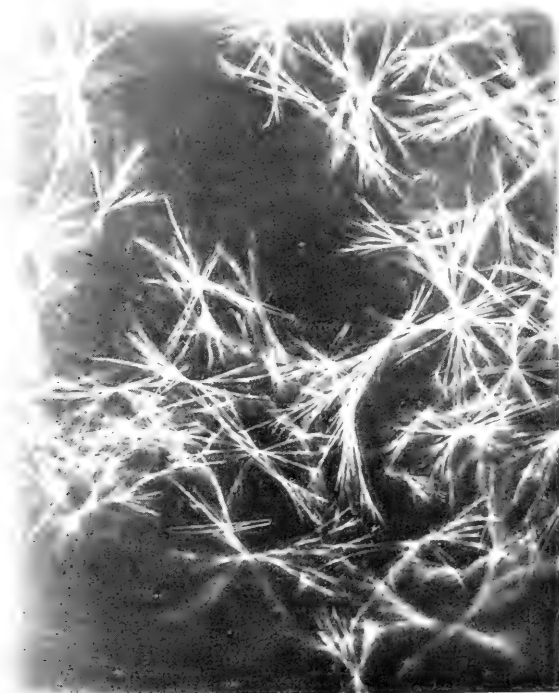

FIG. 22. The crystals of the amino hydrate form of thyroxin.

properties to the imino group of the pyrrole ring of thyroxin. Speculation as to the properties of the compound in which the three iodines are replaced by three hydrogens may be deferred until the substance is prepared synthetically, but that the imino group of the pyrrole ring will be still more basic in this compound would naturally follow from the general law that addition of halogen to the benzene ring renders the ring more acidic. The

position and reason for the three extra hydrogens in thyroxin were unknown and were very puzzling until the reactions of the compound involving the amino and imino groups caused the necessity of explaining this action by some modification of the indole nucleus. Since the introduction of the six hydro groups in aniline greatly increases the basicity of the amino group, the addition of four hydro groups to the indole nucleus of thyroxin is an adequate



FIG. 23. A mixture of enol and keto forms of thyroxin crystallizing simultaneously from the same solution.

explanation of the increased basicity of its amino group. The instability of the pyrrole ring of thyroxin in contrast to that of indole, and other unreduced derivatives of pyrrole is due to the increased basic properties of the nitrogen in thyroxin. This point is well illustrated in the stability of the amino carboxyl form. In neutral solution the nitrogen tends to become triad, the pyrrole

ring is more stable than the amino carboxyl salt, and thyroxin separates in keto form. If a slight amount of acid is present, the nitrogen remains in the pentad state and the amino carboxyl form is so stable that it is impossible to expel water from the molecule and make the keto form. The difference in the basicity of the nitrogen when changing from the open- to the closed-ring forms is probably involved when thyroxin functions physio-



FIG. 24. A mixture of the crystals of the amino carboxyl form changing into the keto form. The small rosettes are crystals of thyroxin in the keto form.

logically. But the unique chemical properties of thyroxin are also due in large measure to the carbonyl group adjacent to the imino, and the reactivity of the substance *in vivo* and *in vitro* is due to the presence of this oxy group in the indole nucleus. It was for this reason that the compound was named thyr-oxy-indole or thyroxin.

After it was found that thyroxin forms amino salts with feeble carboxyl groups, it was of especial interest to form the amino salt of thyroxin with glycine. Reserving a study of the reaction between thyroxin and the amino-acids for a further communication, merely the formation of an amino-acid salt between thyroxin and glycine will be reported in this paper.

Since acid added to the enol form of thyroxin results in the formation of an amino salt, it seemed probable that at least a portion of the nitrogen of thyroxin should react as amino nitrogen with nitrous acid when the molecule existed in the amino-acid salt form. This was tried and it was found that when an alkaline aqueous solution of thyroxin was added to a Van Slyke amino-acid apparatus, approximately 70 per cent of the total nitrogen present was liberated as amino nitrogen. When the keto form of thyroxin was used, no nitrogen was evolved. When the amino carboxyl form of thyroxin is added to nitrous acid, about 15 per cent of its total nitrogen is evolved as amino nitrogen. The reason that a quantitative evolution of amino nitrogen does not occur with the last mentioned form in 3 minutes is because the crystals are insoluble and the reaction takes place at a very slow rate.

When nitrous acid is added to an alcoholic solution or to an aqueous suspension of thyroxin in the presence of hydrochloric acid, a yellow color is produced. Upon the addition of ammonia this is changed to a deep red which in dilute solution is pink. This color reaction is convenient for a rough qualitative test for thyroxin. However, if acetic or sulfuric acid is used in place of hydrochloric, a fainter yellow color is produced, and the addition of ammonia gives a yellowish orange instead of a red color.

During the purification of thyroxin, the presence of colloidal impurities is sufficient to cause the opening of the ring and also to prevent the closing of the ring. When an alkaline solution of thyroxin is acidified the precipitate carries down many of the impurities present as salts of the amino group and hence no quantitative separation can be effected by precipitation with an acid. The chief problem in the isolation of thyroxin is to close the ring in the presence of the impurities, and thereby produce chemical properties specific to the thyroxin molecule, which permit of a separation. This difficulty in closing the open-ring form of thyroxin is well illustrated in the course of its purification. Approxi-

mately 50 per cent of the iodine content in the early steps of the separation of thyroxin is soluble in barium hydroxide. This barium-soluble portion may be hydrolyzed by heating with barium hydroxide for many hours, precipitated with acid, given another treatment with barium hydroxide, and this process continued as many as seven or eight times without rendering thyroxin insoluble in barium hydroxide. This treatment, however, slowly separates many of the impurities and the percentage of iodine in the dry material may reach as high as 58 per cent. Thyroxin in this open-ring form contains sufficient impurities to impart a distinctly yellow color, and it is readily soluble in sodium carbonate, barium hydroxide, pyridine, and alcohol. By chance such a preparation was dissolved in sodium carbonate solution and was allowed to stand 7 weeks. At the end of that time a white residue had separated and settled to the bottom of the flask. Examination showed this to be the monosodium salt of thyroxin. Although the material was in the open-ring form when dissolved in the carbonate, on long standing the ring had closed and the compound thereby became insoluble in sodium carbonate.

The open-ring form of thyroxin cannot be precipitated from alcohol with acetic acid. The keto form of thyroxin is very nearly quantitatively precipitated from alcohol by acetic acid, but as long as impurities are present, an alcoholic solution of the open-ring form of thyroxin may be allowed to stand several weeks without any trace of thyroxin separating. If, however, an alcoholic solution of thyroxin is slowly evaporated on the water bath, the evaporation causes a partial separation. A yellow oily tar creeps up the inclined bottom of the evaporating dish and forms a ring as the alcohol evaporates. At the spot where the last trace of alcohol was left, a dry crusty material, which is almost white, shows the partial separation of thyroxin in the keto form. This property of thyroxin to separate from alcohol, even in the presence of impurities, is the reaction by which thyroxin was first isolated. The alcohol in this case was evaporated unintentionally, and, although the entire sample of thyroxin had been completely soluble in the alcohol, the slow evaporation and subsequent heating at 100° was sufficient to close the ring in a small percentage of the total amount with the result that it was insoluble on the addition of more alcohol. This method of sepa-

ration is not of great value for the isolation of the compound. The best method so far determined for the closing of the ring is to dissolve thyroxin in alcohol containing sodium hydroxide, and pass carbon dioxide through the solution, freeing both hydroxy and carboxyl groups. Most of the sodium carbonate is insoluble and is removed by filtration. The alcohol is distilled, leaving an aqueous sodium carbonate solution of thyroxin but still in open-ring form. Allowing this to stand for several days will cause a separation of the monosodium salt in the enol form which may be purified by similar treatment.

Oxidation and Reduction of Thyroxin.

Quantitative oxidation and reduction experiments with thyroxin have not been carried out because of the amount of material which would be required in order to isolate the products. Thyroxin is more susceptible to reduction than to oxidation. Zinc in alkaline or acid solution breaks off iodine and appears to alter the organic nucleus. Thyroxin is reduced when heated in the presence of any metal in alkaline solution other than nickel and the heavy metals, silver, gold, and platinum. Thyroxin is stable in the presence of mild oxidizing agents. Hydrogen peroxide produces no immediate effect and in a cold acid suspension the molecule will resist oxidation with potassium dichromate or iodic acid. Potassium permanganate or bromine in hot aqueous solution causes the breaking down of the molecule. Benedict's copper solution, for the determination of sugar, causes an oxidation of thyroxin in the presence of sodium hydroxide. In the presence of ammonium hydroxide alone, thyroxin is stable in Benedict's solution heated to boiling. Free iodine if added to an alkaline solution produces a precipitate and apparently brings about a deep-seated reaction within the molecule. In acetic acid or acid alcohol, iodine has very little, if any, effect on thyroxin even at the temperature of boiling acetic acid. Further investigation showed that, in the presence of iodine,¹ thyroxin is stable in the keto form, but not in the enol form. The changes produced by oxidation with chlorine, bromine, and iodine, have not been determined, but in alkaline solutions yellow tarry products are formed. Since the enol form of thyroxin is so

much less stable than the keto, the weakness in the molecule appears to be in the linkage of the nitrogen, and the point of cleavage is probably between the nitrogen and the hydroxy groups. When the imino carbonyl groups are present, the molecule is much more resistant to oxidation by halogen.

Another point of weakness within the molecule exists in the benzene ring. The completely reduced benzene ring readily passes over into a six carbon, straight chain form. Hexa-hydrophenol may be readily oxidized to adipic acid by the action of dilute nitric acid. In thyroxin the benzene ring is in the tetrahydro form, and it is highly probable that the one double-bond which is present will break down with the formation of an open chain structure. A reaction similar to this is found in the oxidation of the tetra-hydro-benzene ring of sedanonic acid (2) to straight chain acids.

Due to the weakness of the linkages to the nitrogen in thyroxin, it is impossible to hydrolyze derivatives from the imino group. After the acetyl radical has been attached to the imino group, it cannot be hydrolyzed with sodium or potassium hydroxide. When treated with alkali, the compound precipitates as a di-metal salt, and is thrown out of solution. If sufficiently drastic action is applied to bring about the hydrolysis, disruption of the molecule occurs.

Thyroxin upon exposure to the sunlight in weak alkaline solution is very unstable. Within 24 hours the solution changes from colorless to a pink, or faint yellow, which deepens on standing to a brown color, depending on the amount of thyroxin present. Simultaneously with the discoloration a distinct aromatic odor is produced slightly resembling that of nicotine. Such a solution, when tested for iodine by means of starch in acid solution, shows that no iodine has been broken off in the free form. If, however, a small amount of potassium iodide is added, iodine is immediately liberated, which indicates that the iodine within the thyroxin molecule was not broken off either as hydriodic acid or as iodine, but in the form of hypoiodous acid. On longer standing a test for free iodine is given without the addition of potassium iodide and the amount of hypoiodous acid is much reduced. After several weeks no test for iodine or hypoiodous acid is given, but all the iodine is found in the form of hydriodic

acid. The reduction of the hypiodous acid to hydriodic acid is probably brought about by the hydroindole nucleus. The finding that iodine is broken off from the thyroxin molecule in the form of hypiodous acid and not as hydriodic has direct bearing on the physiologic action of the molecule within the body.

The Acetyl Derivative.

With the acetyl, sunlight produces a similar reaction, but in this case the solution is found to contain both hypiodous acid and iodine. The acetyl derivative, therefore, is more susceptible to oxidation than thyroxin, and brings about a much more rapid reduction of the hypiodous acid to iodine and hydriodic acid.

So unstable is the acetyl under certain conditions that there is a spontaneous liberation of iodine from the molecule and the simultaneous oxidation of the organic nucleus, resulting in a change of color and the production of a yellow tarry material. The conditions under which it is produced appear to be in a solution of approximately the neutrality of distilled water. If barium or calcium chloride is added to a sodium hydroxide solution of the acetyl, and the solution is boiled, no decomposition of the barium or calcium salts occurs. If magnesium chloride is used in place of barium or calcium, the basicity of magnesium hydroxide is insufficient to prevent the decomposition of the acetyl, and there is a spontaneous liberation of iodine accompanied with production of a blue color, which changes to green, and finally to yellow. This same reaction occurs if the sodium salt of the acetyl is dissolved in distilled water and allowed to stand without the addition of sodium hydroxide. Also if the disodium salt is filtered on a small Buchner funnel, washed with sodium chloride, and allowed to stand in a moist condition there is rapid liberation of iodine and production of bluish green colors, which fade to yellow. If small pieces of the acetyl in dry form are added to water, alcohol, or pyridine containing alkali, the solution of the solid material is accompanied by decomposition in part with a liberation of iodine and discoloration. If the acetyl is dissolved in alcohol the addition of sodium hydroxide to the solution will form the sodium salt of the acetyl without decomposition or liberation of iodine. Furthermore, an alkaline solution can be added to acid with precipi-

tation of the acetyl without decomposition. In both acid and alkaline solutions the acetyl is as stable as thyroxin, but at the neutral point a spontaneous decomposition occurs. One of the factors which affects this reaction is the mass of material present. In dilute solutions the decomposition of the acetyl is very much slower, and in sufficiently dilute solutions it may not occur at all. This effect of the mass of material explains why solution in alcohol prevents the destruction of the acetyl with addition of alkali. The mechanism is essentially the diminution of the concentration of the acetyl. Great difficulty was encountered in the preparation of the acetyl until the factors influencing the decomposition were discovered. As thyroxin does not react in this way no difficulty was anticipated, and it was only after identification of free iodine in the solutions of the acetyl which had turned bluish green that an insight into the mechanism was obtained. Why the acetyl derivative spontaneously decomposes at the neutral point and gives off iodine in the free form instead of hypiodous acid, as occurs with thyroxin, is not known.

The reactions resulting in the oxidation of the acetyl and liberation of iodine are also given by the ureide under similar conditions. This excludes the possibility that the acetyl radical is necessary for the decomposition and suggests that the reason for the instability is the replacing of the imino hydrogen by a larger group.

When this decomposition has occurred in part, the products cannot be removed from the rest of the material, and it is impossible to separate the acetyl in free form. The tarry products resulting from the decomposition of a small part prevent the crystallization of the rest of the acetyl. The retention of impurities by the acetyl is very similar to the retaining of impurities by partially purified thyroxin.

Beside the spontaneous decomposition, other reactions which are specific to the acetyl were found which will be discussed at this time. It was found that when the acetyl was freshly precipitated from an alkaline solution by an acid it is soluble in ether. After it has been separated in crystalline form and dried it is insoluble in ether. This difference in solubility is undoubtedly due to the acetyl existing in open-ring form when precipitated from cold water solution. The closed-ring form is insoluble in ether.

When the acetyl derivative is prepared by adding acetic anhydride to an alkaline alcoholic solution of thyroxin, and the alcoholic solution of the acetyl is then added to ether the acetyl is removed only partially by subsequent extraction of the ether with sodium hydroxide. A large amount of the acetyl remains in the ether. If the ether solution is tested with nitrous acid the usual reaction with the production of a yellow color turning to red with the addition of ammonia, does not occur. After alcoholic sodium hydroxide is added and the solution is heated, a typical reaction with nitrous acid will take place. Another difference of the acetyl before and after the treatment of the ether solution with alkali is shown in the solubility of the acetyl in alkalies. If the ether is evaporated before alkaline hydrolysis, the acetyl is found to be very difficultly soluble in aqueous sodium hydroxide. After hydrolysis in alkaline alcohol, the acetyl is very easily soluble in dilute alkali. The non-reactivity with nitrous acid and insolubility in alkali may be due either to the formation of an inner salt between the carboxyl and imino, or to the formation of a diacetyl derivative. Treatment with alkalies hydrolyzes either the acid salt or one acetyl group, and the acetyl in free form is liberated.

The Action of Sunlight on Thyroxin, and the Production of Colored Compounds from Thyroxin.

When thyroxin, the acetyl, or the ureide is dissolved in dilute sodium hydroxide and allowed to stand in the sunlight, the solution slowly changes, and in the course of 12 to 72 hours develops a distinctly pink color. On further standing the pink color is changed to yellow. When the carbonic acid derivative was prepared by treating thyroxin with phosgene, it was found to be unstable and changed to a deep pink. When the sodium or barium salt of thyroxin is allowed to stand exposed to sunlight in a dry form, it also develops a pink color. With the barium salt this action does not occur in the dark, or when the salt is covered with water. The development of the pink color in each case is accompanied by the splitting off of iodine in the form of hypoiodous acid. This pink color was first noticed on the edges and outside of white porcelain casseroles which were used to extract

the barium salt of thyroxin with sodium hydroxide. Where the solution dried and was exposed to heat and light the pink color developed. Later this was shown to be due to the thyroxin itself and not to the impurities present. The chemical structure of the pink-colored compound is still unknown, but it appears probable that it is an oxidation product of the hydroindole nucleus. The effect of light on the separation of thyroxin is of importance, and loss of thyroxin due to the action of light may amount to a considerable percentage of the total unless precautions are observed not to permit the action of direct sunlight to destroy the partially purified thyroxin.

Effect of Acid and Alkali on Thyroxin.

No quantitative determinations have been made as yet concerning the ultimate products of alkaline hydrolysis because of the amount required to isolate the decomposition products. Thyroxin is not affected at room temperature by any concentration of aqueous sodium hydroxide. It is soluble in dilute alkali and after the concentration has reached 10 to 15 per cent the disodium salt separates. The further addition of alkali renders the sodium salt more insoluble but it does not cause any destruction of thyroxin. Although thyroxin is stable in sodium hydroxide at room temperature, when it is heated above 110° in the presence of strong sodium hydroxide, there is a destruction of the molecule with the splitting off of sodium iodide, and eventually the liberation of indole which may be identified by the pine-splinter reaction. The amount of indole liberated is not quantitative and it is probable that only traces of the hydroindole nucleus appear as indole.

In acids thyroxin is not so stable as in the presence of alkali. In aqueous solutions of pure thyroxin, hydrochloric or sulfuric acids precipitate the hydrochloride or sulfate of thyroxin, and, since these are insoluble, the destruction of thyroxin is prevented. However, when thyroxin is present in open-ring form, strong acids bring about reactions with the impurities and oily tarry products result. In alcohol solutions prolonged action of hydrochloric acid causes a destruction in part even with pure thyroxin, resulting in the production of a brown discoloration. Poly-

merization of indole compounds in the presence of acid is well established, and it seems probable that this explains the destructive action of acids on thyroxin.

A Consideration of Other Possible Structural Formulas.

Accepting the empirical formula as $C_{11}H_{10}O_3NI_3$, the carbonyl group in the molecule could be present as a ketone, either attached to the side chain or to the benzene ring. That this is not the case is shown by the failure of thyroxin to react with hydrazine, phenylhydrazine, or semicarbazone. The carbonyl group adjacent to the imino should not react with hydrazine and the failure of thyroxin to react is evidence corroborating the hypothesis that the carbonyl group is adjacent to the imino. The positions of the three iodine atoms, the three extra hydrogen atoms, and the three carbon atoms in excess of the indole nucleus have not been determined by substitution or by decomposition products. The most conclusive proof of the position of the three carbon atoms and the terminal carboxyl would be furnished by the synthesis of thyroxin. The synthesis of thyroxin will be reported in another paper, but at this time the synthesis of the compound will be cited as evidence for the correctness of the structural formula assigned in regard to the position of the three carbon atoms with terminal carboxyl. The establishment of the fact that thyroxin does not rotate polarized light excludes an asymmetric carbon atom and confirms the arrangement of the double-bonds.

The Crystal Form and Melting Point of Thyroxin.

The keto form of thyroxin crystallizes in six distinctly different forms (Figs. 25 to 30). Each of the seven other forms of thyroxin has characteristic crystal forms. The di-basic and mono-basic metal salts and the amino- and imino acid salts of thyroxin also have characteristic forms.

The crystal forms of imino acid salts and of di- and mono-metal salts are flat plates for the most part. The other crystal forms are long branching needle blades or thread-like needles which occur in rosettes, or in sheaves, or in tangled masses.

Beside the type of crystal, all these forms and derivatives of thyroxin also have characteristic melting points. For these reasons microscopic study of the crystals and the determination of the melting point are the two methods which have proved of greatest value during this investigation. The determination of iodine is not of such value because the iodine content of any one



FIG. 25.

FIGS. 25 to 30. Six different types of crystals in which the keto form of thyroxin separates.

form may vary within wide limits without greatly affecting either the melting point or the crystal form. A good illustration of this is in the keto form of thyroxin. The keto form of thyroxin when pure melts at 250° , when slightly impure the melting point drops to 246° or 245° , and when grossly contaminated with impurities it drops to 240° . This point, however, appears to be the limiting value below which the keto form seldom melts. It appears that

merely dissolving thyroxin in alkali and precipitating it causes a slight decomposition. The decomposition products are retained by the pure thyroxin and are separated with great difficulty. However, the presence of these impurities rarely exceeds the amount which lowers the melting point to the neighborhood of 240° . Microscopically the keto type of crystals could be identi-

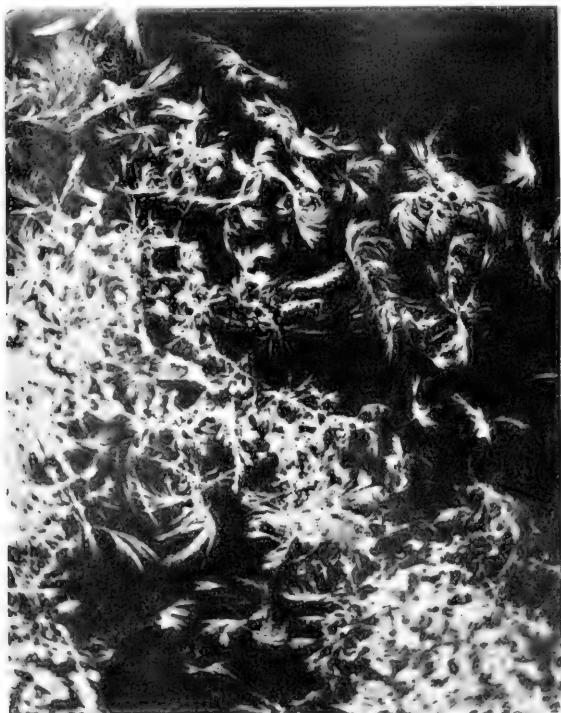

FIG. 26.

fied, and the melting point of 240° or above would confirm the form in which thyroxin existed but the iodine content might vary as much as 2.5 per cent from the theoretical. The keto form melts the highest of all forms or derivatives of thyroxin, from 240 – 250° , the amino carboxyl form melts in the neighborhood of 225° ; the amino hydrate melts at 216° , and the enol form at 204° ; the imino acid salts melt at about 228° ; the amino-acid

salts in the neighborhood of 204° ; the derivatives of thyroxin attached to the imino, in closed-ring form, melt at about 238° and in open-ring form at about 152° . It is apparent that the melting points of different forms and derivatives are so widely separated that no misinterpretation could result except in cases of mixtures, and the crystal form is so definite that mixtures can

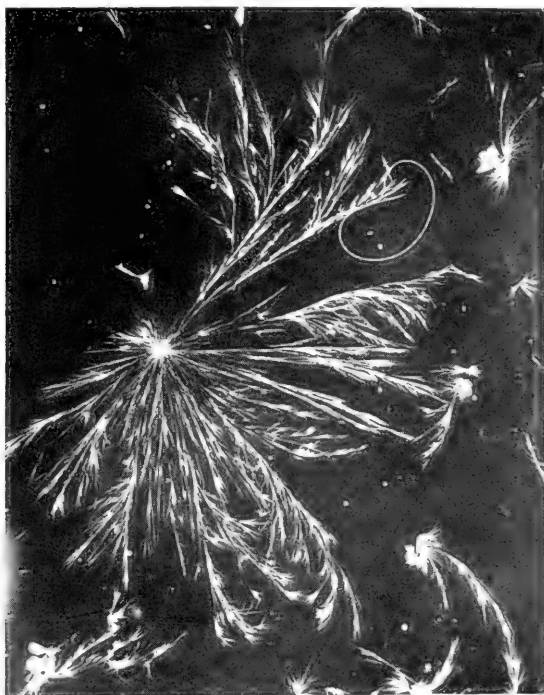

FIG. 27.

be identified under the microscope. It has been found, however, that the melting point varies greatly with the rate of heating. One sample of thyroxin, which melted at 240° when heated at the rate of 10° increase per minute, melted at 248° when heated at the rate of 18° increase per minute, and at 221° when heated at the rate of 0.6° increase per minute.



FIG. 28.



FIG. 29.

For a routine determination we have adopted the rate of 10° increase per minute, and when the melting point is observed under these conditions each form of thyroxin and its derivatives agree very closely in their melting points, with other samples of the same form.

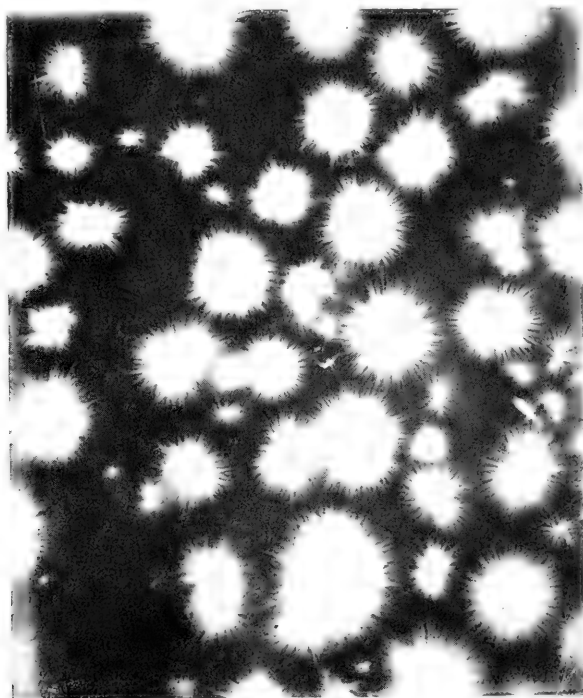

FIG. 30.

EXPERIMENTAL.

The Percentage of Iodine in Thyroxin.

Eighteen different samples of thyroxin have been prepared, the weights of the samples ranging from 900 mg. to 5 gm. All the samples contained at least 63.5 per cent of iodine and six

were purified until they contained approximately 65 per cent of iodine. The iodine content² of Samples 1 to 6 is as follows:

*Iodine Content of Thyroxin.*²

Sample 1.	5.10 mg.	contained	3.31 mg.	of iodine	= 64.81 per cent.
“ 2.	5.12 “	“	3.32 “	“	= 64.86 “ “
“ 3.	5.24 “	“	3.41 “	“	= 65.02 “ “
“ 4.	5.10 “	“	3.32 “	“	= 65.00 “ “
“ 5.	25.3 “	“	16.45 “	“	= 65.00 “ “
“ 6.	4.51 “	“	2.66 “	“	= 65.02 “ “

Precipitation of thyroxin from alkaline alcohol with acetic acid, or by boiling an ammoniacal solution, does not vary the percentage of iodine. Precipitated with acetic acid from alkaline alcohol the iodine content of thyroxin was 64.95 per cent. Precipitation of the same preparation by boiling an ammoniacal solution gave an iodine content of 64.92 per cent. 50 mg. of thyroxin were dissolved in 200 cc. of water containing 3 cc. of concentrated ammonium hydroxide. The solution was boiled down to 100 cc. 100 cc. of water were added and the solution was boiled for a few minutes, cooled, and filtered. 15 cc. of filtrate contained 0.20 mg. of iodine.

Solubility = one part in 48,800.

Ultimate Analysis of Thyroxin.

Sample No.	Weight of sample.	CO ₂	H ₂ O	Carbon.	Hydrogen.	Iodine.
	<i>mg.</i>	<i>mg.</i>	<i>mg.</i>	<i>per cent</i>	<i>per cent</i>	<i>per cent</i>
7	201.4	175.2	32.3	23.72	1.78	64.95
7	171.2	148.0	26.9	23.57	1.74	64.95
8	291.0	248.8	45.7	23.32	1.74	64.92
9	124.2	101.9	18.5	22.37	1.65	65.02

102 mg. of thyroxin contained 2.27 mg. of nitrogen = 2.23 per cent.

	Carbon.	Hydrogen.	Oxygen.	Nitrogen.	Iodine.
	<i>per cent</i>	<i>per cent</i>	<i>per cent</i>	<i>per cent</i>	<i>per cent</i>
Calculated for C ₁₁ H ₂ O N I ₂	22.56	1.70	8.20	2.39	65.10
Found.....	22.37	1.65	8.73	2.23	65.02

² The iodine was determined by a method published in 1914, which has been modified recently so that it is now applicable for the determination of small amounts of iodine to a high degree of accuracy (The determination of iodine in connection with studies in thyroid activity, Kendall, E. C., *J. Biol. Chem.*, 1914, xix, 251).

Solubility of Keto Form of Thyroxin.

50 mg. of thyroxin were dissolved in 200 cc. of dilute sodium hydroxide. 20 cc. of 50 per cent hydrochloric acid were added and the solution was boiled; 15 cc. of the filtrate contained 0.116 mg. of iodine.

Solubility = one part in 84,000.

The Sulfate of Thyroxin.—For the preparation of the sulfate 50 mg. of thyroxin are dissolved in 200 cc. of water containing 50 to 100 mg. of sodium hydroxide; 20 cc. of 50 per cent sulfuric acid are added, and the solution is boiled. The sulfate of thyroxin is soluble at 100°, but on cooling settles to the bottom of the container in oval-shaped plates. It may be filtered on a Buchner funnel, washed with water, and dried in a desiccator.

Analysis of the Sulfate of Thyroxin.

Sample 1. 5.48 mg. contained 3.27 mg. of iodine = 59.71 per cent.

" 2. 25.00 " " 15.00 " " " = 60.00 " "

114.4 mg. of thyroxin sulfate gave 86.9 mg. of carbon dioxide, 18.1 mg. of water; 5.08 mg. contained 3.04 mg. of iodine.

	Carbon.	Hydrogen.	Iodine.
	<i>per cent</i>	<i>per cent</i>	<i>per cent</i>
Calculated for $C_{11}H_{11}O_5NI_3S_2$	20.82	1.73	60.09
Found.....	20.71	1.75	59.92

50 mg. of thyroxin were dissolved in 200 cc. of sodium hydroxide precipitated with 20 cc. of 50 per cent sulfuric acid, and the solution was boiled; 15 cc. of the cooled filtrate contained 0.127 mg. of iodine.

Solubility = one part in 76,900.

The Hydrochloride of Thyroxin.—The hydrochloride of thyroxin is best prepared by dissolving a small amount of thyroxin, 15 to 25 mg. in 5 or 6 cc. of alcohol containing 2 to 3 cc. of 50 per cent hydrochloric acid. 1 to 2 cc. of water are added, and the alcohol is boiled off in a test-tube. After most of the alcohol has been distilled the hydrochloride will separate in flat, glistening plates. If too small an amount of acid is used, or too much water, the hydrochloride will hydrolyze, and the plates will change to needles.

The Metal Salts of Thyroxin.—Dry crystalline thyroxin is readily soluble in sodium and potassium hydroxides in the cold, if the concentration of the alkali is less than 10 to 15 per cent. Thyroxin is insoluble in sodium or potassium hydroxide in the cold if the alkali is stronger than 15 to 20 per cent, but it is more soluble in strong alkali if the solution is warmed. In a mixture of 66 per cent of alcohol and 33 per cent of water containing 1 per cent of sodium hydroxide, thyroxin may be dissolved to the extent of about 4 per cent. It is still more soluble in hot solutions but on cooling will separate as the di-metal salt. Thyroxin is not readily soluble in dilute ammonia, but concentrated ammonia will dissolve about 1.8 per cent of thyroxin.

The Di-Basic Sodium and Potassium Salts.—100 mg. of thyroxin are dissolved in 20 cc. of dilute sodium hydroxide and to this are added 150 cc. of a solution of 10 per cent sodium hydroxide containing 20 per cent of sodium chloride. If a precipitate occurs the solution is warmed and the clear solution is then allowed to stand until cold. The exact concentrations of sodium chloride and hydroxide are not important. The disodium salt readily separates in any solution containing a high concentration of sodium salts. If the strongly alkaline solution is decanted and replaced with 15 per cent sodium chloride solution, the crystals may be filtered through a Buchner funnel on paper. They are insoluble in 10 to 15 per cent sodium chloride and may be washed and dried. The disodium salt cannot be prepared in pure form for analysis as washing with water dissolves the salt, and it passes through the paper. The di-basic potassium salt is prepared in a way similar to that used for the sodium salt. The diammonium salt is prepared by dissolving thyroxin in hot concentrated ammonium hydroxide and allowing the solution to cool. Flat, rectangular crystals of the diammonium salt will separate.

The Alkaline Earth Salts of Thyroxin.—The barium, calcium, and magnesium salts of thyroxin are prepared by dissolving 50 to 100 mg. of thyroxin in 100 cc. of dilute sodium hydroxide using as small an amount of alkali as possible to carry the thyroxin into solution. The solution is heated to boiling and 20 cc. of a 20 per cent solution of barium, calcium, or magnesium chloride are added to the hot solution of thyroxin. Carbon dioxide is excluded by placing the beaker in an atmosphere free of carbon

dioxide. The magnesium and calcium salts are very slightly soluble in boiling water. 500 cc. of boiling water will dissolve between 100 and 150 mg. of the barium salt. The barium salt may be suspended in boiling water and the solution filtered through a Buchner funnel into a suction flask. 30 cc. of 20 per cent barium chloride are now added to the filtrate and the barium salt is allowed to recrystallize. Only a negligible amount of thyroxin is soluble in the presence of this amount of barium chloride. The barium salt under these conditions is unstable and will slowly turn a pink color. Analysis for iodine shows a lower iodine content than that calculated.

Iodine Content of Barium Salt.

Sample 1.	6.76 mg.	contained	3.26 mg.	of iodine	=	48.51	per cent.
"	2.598	"	3.00	"	"	50.24	"
Calculated for $\text{BaC}_{11}\text{H}_5\text{O}_3\text{NI}_3$:						52.91	"

If the barium salt is filtered and dried there is a slow decomposition and the color of the salt becomes yellowish gray.

Silver, Copper, Nickel, and Zinc Salts of Thyroxin.—The silver, copper, nickel, and zinc salts are prepared by dissolving 50 to 100 mg. of thyroxin in 25 to 50 cc. of concentrated ammonia. 25 cc. of a 10 per cent solution of silver nitrate, copper sulfate, nickel sulfate, or zinc sulfate are made ammoniacal with strong ammonia so that the precipitated hydroxide is just carried into solution, and there is a slight excess of ammonia. The solution of the metal is now added to the ammoniacal solution of thyroxin, and after standing a short time the crystals of the metal salt will separate. If too much ammonia is used, a larger amount of the solution of the metal may be required to start the crystallization. Allowing it to stand over night will insure a more complete precipitation. Sodium hydroxide may be used for the solution of thyroxin, but, since the metal salt of thyroxin is more soluble in sodium hydroxide, ammonium hydroxide has been found to be the most satisfactory solution. The silver, copper, nickel, or zinc salts suspended in water or dilute ammonia are soluble on the addition of several cc. of 30 per cent sodium hydroxide solution.

Iodine Content of Silver Salt.

Sample 1.	4.86 mg.	contained	2.37 mg.	of iodine	=	48.74 per cent.
"	2.4.96 "	"	2.44 "	" " "	=	49.15 " "
"	3.4.00 "	"	1.97 "	" " "	=	49.34 " "
"	4.4.06 "	"	1.99 "	" " "	=	49.10 " "
"	5.4.54 "	"	2.23 "	" " "	=	49.20 " "
"	6.4.08 "	"	1.96 "	" " "	=	48.00 " "
"	7.6.02 "	"	2.93 "	" " "	=	48.60 " "
"	8.4.38 "	"	2.09 "	" " "	=	47.73 " "
Calculated for	$\text{Ag}_2\text{C}_{11}\text{H}_5\text{O}_3\text{NI}_3$:				47.74	" "
"	$\text{AgC}_{11}\text{H}_5\text{O}_3\text{NI}_3$:				55.06	" "

The average of these eight determinations is 48.73 per cent iodine. The iodine content indicates the addition of 92 per cent of the theoretical amount for a di-metal salt and 184 per cent of the amount required for a mono-metal salt. The higher iodine content than that calculated for a di-metal salt is undoubtedly due to the hydrolysis of the hydroxy group. In the zinc salt, the amount of iodine was found to be 56.95 per cent. The calculated amount for the zinc salt is 58.79 per cent, but the calculated amount of iodine in the zinc salt in which hydrolysis of the hydroxy group had occurred would be 57.12 per cent. The close agreement between the amount found and the latter figure is evidence that hydrolysis of the hydroxy group also occurs in the zinc salt of thyroxin. The low iodine content of the salts of the diad metals, barium and zinc, and the high iodine content of the salt of the monad metal, silver, suggest that in all di-metal salts of thyroxin hydrolysis of the hydroxy group is brought about by washing the salt with water.

Preparation of Mono-Metal Salts.—100 mg. of thyroxin are dissolved in 150 cc. of 1 per cent sodium hydroxide, and carbon dioxide is bubbled through the solution until thyroxin is precipitated. The suspension is now heated until solution is complete. On cooling, the monosodium salt separates in crystal form. The separation of the mono-salt is assisted by the presence of sodium salts and is hindered by too great a dilution. An excess of carbon dioxide must not be passed through the solution, as free thyroxin will be precipitated. The preparation of the potassium salt is similar to that of the sodium salt. In preparing the ammonium salt, strong ammonium hydroxide is much better than dilute, as

the solubility of the ammonium salt is thereby decreased. If the mono-metal salt is filtered on a Buchner funnel and washed with 10 to 15 per cent sodium, ammonium, or potassium chloride, it is not dissolved through the paper. If washed with cold water, about 40 per cent is dissolved and 60 per cent of the amount of thyroxin taken remains on the paper in the form of free thyroxin in the enol form.

Nesslerization of the Hydrolyzed Monoammonium Salt of Thyroxin.

50 mg. of the residue left on the paper after washing the mono-ammonium salt with water were dissolved in 60 cc. of ammonia-free water containing a small amount of sodium hydroxide. The addition of 15 cc. of Nessler's solution and dilution to 100 cc. produced no color, showing hydrolysis of the monoammonium salt was complete.

Solubility of Monosodium Salt.—5 cc. of 0.10 per cent sodium carbonate dissolved about 15 mg. of dry thyroxin in keto form, when the solution was heated to boiling. Most of the thyroxin reprecipitated on cooling to 20°, but not as the monosodium salt. The crystals were needles or very small rosettes. 1 cc. of the filtrate contained 0.76 mg. of iodine = 1.17 mg. of thyroxin.

Solubility = one part in 850.

5 cc. of 1 per cent sodium carbonate dissolved 85 to 90 mg. of thyroxin at almost the boiling point. Probably more than this amount could be dissolved but as the solution began to turn yellow the heating was stopped. On cooling to 23°, needles in clusters and square plates of monosodium salt separated. 1 cc. of filtrate contained 1.14 mg. of iodine = 1.75 mg. of thyroxin.

Solubility = one part in 570.

The Enol Form of Thyroxin.—The enol form of thyroxin is the most difficult to prepare in crystalline form, but is very easily prepared in the crystal form of the mono-metal salts by cold water hydrolysis of the monoammonium, sodium, or potassium salts. 10 to 20 mg. of the enol form in dry powder is readily soluble in 1 to 2 cc. of pyridine. The addition of 10 to 15 cc. of water will produce a cloudiness. On long standing (24 hours), the thyroxin will precipitate. Depending on conditions of the concentration of pyridine and the amount of thyroxin present,

the thyroxin may precipitate in keto form. This may be distinguished under the microscope as long bundles, or sheaves of needles. The enol form separates in either rosettes, or short bundles of needles. The enol form of thyroxin is also soluble in quinoline. Other ways to prepare the enol form of thyroxin is to add ammonium chloride to a cold solution of the disodium salt in water which does not contain an excess of alkali, or to dissolve the disodium salt of thyroxin in alcohol and add water and ammonium chloride. A mixture of both keto and enol crystals usually results if much alcohol is present.

10 to 15 mg. of dry crystals of the keto form of thyroxin may be boiled with 5 to 10 cc. of pyridine without going into solution. The addition of a very small amount of dilute ammonia will change the thyroxin to the enol form and carry it into solution. The water may then be boiled off and the enol form remains soluble in pyridine. If 15 to 20 mg. of the enol form of thyroxin are dissolved in 2 to 3 cc. of pyridine in a test-tube, and to this 10 to 15 cc. of water are added, and the solution is boiled, after the pyridine has been removed by distillation, thyroxin will separate in the keto form similar to the precipitation of thyroxin from a boiling ammoniacal solution.

25 mg. of thyroxin added in the keto form to 10 cc. of water in the presence of 1 gm. of sodium carbonate will not dissolve. If alcohol is used instead of water and the alcohol is boiled, the sodium carbonate does not dissolve but the thyroxin is carried into solution. The monosodium salt of thyroxin in the enol form produced by the alcoholic suspension of sodium carbonate is readily soluble in alcohol.

The Amino-Acid Salt Form of Thyroxin.—For the preparation of amino-acid salts, thyroxin is dissolved in a small amount of sodium hydroxide in a large volume of water, and to this carbon dioxide or other organic acid is added until thyroxin precipitates. The voluminous precipitate is filtered, washed, and dried. In order to prepare the amino salts in crystalline form, other expedients may be used. For the preparation of the amino sulfate, thyroxin is dissolved either in formic acid or in alcohol containing a small amount of sulfuric acid. The alcohol is concentrated to small volume, and water is quickly added in large volume.

Solubility of Thyroxin in Amino Salt Form.

Hydrochloride.—50 mg. of thyroxin were dissolved in 200 cc. of dilute sodium hydroxide, and precipitated at 25°C. with a slight excess of hydrochloric acid, 15 cc. of the filtrate, after removing the precipitate of thyroxin, contained 0.037 mg. of iodine.

Solubility = one part in 263,000.

Carbonate.—50 mg. of thyroxin were dissolved in 200 cc. of dilute sodium hydroxide, and precipitated by passing carbon dioxide through the solution; 15 cc. of the filtrate contained 0.012 mg. of iodine.

Solubility = one part in 815,000.

Iodine Content of Amino Carbonate.

5.8 mg. contained 3.137 mg. of iodine = 60.57 per cent.

Calculated for $C_{11}H_{12}O_4NI_3(H_2CO_3)_{\frac{1}{2}}$ = 60.09 " "

The slightly higher figure for iodine than the calculated amount is probably due to separation of the thyroxin in either the enol or amino hydrate form, or to the hydrolysis of the amino carbonate and formation of the amino carboxyl. This sample of thyroxin contained 65.02 per cent of iodine when precipitated in keto form.

The Amino Carboxyl Form of Thyroxin.—The amino carboxyl form is prepared by suspending the amino-acid salt form of thyroxin in water in the presence of a small amount of weak organic acid, such as acetic, and boiling the solution. The acid radical is expelled from the amino group, and the adjacent carboxyl group forms an amino carboxyl salt. It can also be prepared by dissolving the disodium salt of thyroxin in a large volume of water, heating to boiling, adding ammonium chloride, and continuing the boiling. The amino carboxyl form of thyroxin separates.

If no acid is present the elements of water may be expelled from the molecule and thyroxin will separate in keto form.

Iodine Content of Hydrolyzed Amino-Acid Salts.

A sample of amino carbonate was suspended in neutral distilled water and the solution was boiled 3 minutes. This was not sufficiently long to complete the hydrolysis.

5.38 mg. contained 3.321 mg. of iodine = 61.72 per cent.

The same sample boiled 15 minutes showed that all of the carbonate had been expelled and also that some of the amino carboxyl form had been converted into the keto form.

5.2 mg. contained 3.305 mg. of iodine = 63.56 per cent.

A sample of amino sulfate suspended in distilled water and boiled more nearly approximated the amino carboxyl form, but in this case all the sulfate radical was not hydrolyzed.

5.0 mg. contained 3.135 mg. of iodine = 62.72 per cent.

Calculated for amino carbonate, 60.09 per cent iodine.

"	"	"	sulfate,	58.43	"	"	"
"	"	"	carboxyl,	63.18	"	"	"

Preparation of the Amino Hydrate Form.—Thyroxin is dissolved in a large volume of water with a moderate excess of sodium hydroxide. The solution is heated to boiling and then removed from the flame, and 10 per cent ammonium chloride is slowly added to the amount of 10 to 15 cc. The solution becomes turbid, and long branching crystals separate. The limits of the concentration of the hydrogen ion and the temperature for the formation of the enol, amino hydrate, amino carboxyl, and the keto forms are very narrow. If thyroxin is dissolved in a few mg. of sodium hydroxide, and the solution is diluted to about 400 cc., and divided into four equal parts, each of the four different forms of thyroxin may be prepared from these solutions merely by varying the conditions of the precipitation. Ammonium chloride added to one of the solutions in the cold, will precipitate the thyroxin in the enol form, or as the monoammonium salt in flat plates. If ammonium chloride is added to the second solution, which has been heated to boiling, and then removed from the flame, the amino hydrate form will separate. If the amino hydrate is precipitated in the third, and the solution containing a suspension of the amino hydrate is heated to boiling and the boiling continued, the crystals will change into the amino carboxyl form. If a large excess of ammonium chloride is added to the fourth solution, and the solution is boiled, thyroxin will separate in the keto form.

Open-Ring Form in the Presence of Impurities.—The percentage of iodine in the open-ring form of thyroxin, which is still soluble

in pyridine, sodium carbonate, barium hydroxide, and alcohol, may be between 50 and 60 per cent.

Iodine Content of Thyroxin Still in Open-Ring Form.

Sample 1.	5.00 mg.	contained	2.51 mg.	of iodine	=	50.28	per cent.
"	2. 3.92	"	"	2.13	"	"	" = 54.21
"	3. 6.44	"	"	3.51	"	"	" = 54.46
"	4. 4.16	"	"	2.43	"	"	" = 58.53

The solubility of these samples in alcohol, sodium carbonate, and barium hydroxide showed that although the amount of impurities present was very small, the ring still existed in open form.

Colloidal Substances Producing the Open-Ring Form of Thyroxin.—50 to 100 mg. of pure thyroxin, added to the impurities which are separated during the process of purification, will become readily soluble in alcohol, sodium carbonate, and barium hydroxide, showing the change from the keto to the open-ring form. Gelatin and proteins of blood produce the same changes, but the amino-acids resulting from the hydrolysis of gelatin will not change the solubility of thyroxin in barium hydroxide, alcohol, or sodium carbonate.

The Acetyl Derivative.

Preparation of the Acetyl.—In the preparation of the acetyl it is necessary to use pure thyroxin. The presence of even a small amount of impurities makes it impossible to crystallize the acetyl and it will separate only as an oily tar. 100 mg. of pure thyroxin are added to 20 cc. of alcohol containing 100 mg. of sodium hydroxide. After the thyroxin is entirely dissolved 2 cc. of acetic anhydride are added. The solution is allowed to stand for 30 minutes, 5 cc. of water and 5 cc. of 50 per cent sulfuric acid are added, and the alcohol is evaporated by boiling in a 200 cc. distilling flask under diminished pressure. The temperature is not allowed to go above 40°C. Crystals of the sulfate of the acetyl separate as the alcohol is removed. These are dissolved in about 15 cc. of alcohol which is filtered and added to a beaker containing 200 cc. of boiling water and 5 cc. of 50 per cent sulfuric acid. The addition of the first few drops of the alcohol solution of the acetyl does not cause a precipitate but further addition of the alcohol solution causes a precipitation in crystalline form of the free acetyl.

Purification of the acetyl may also be carried out by dissolving the acetyl sulfate in 25 cc. of alcohol and adding 5 gm. of sodium acetate and 10 cc. of 30 per cent sodium hydroxide. After the alcohol has been removed by boiling under diminished pressure, the disodium salt of the acetyl will separate in large, flat plates. The sodium salt may then be dissolved in alcohol and precipitated by addition to a boiling solution of dilute sulfuric acid as described above.

Many samples of the acetyl have been prepared and analyzed. Some of the results are as follows:

Analysis of the Acetyl of Thyroxin.

Sample 1.	5.26 mg.	contained	3.20 mg.	of iodine	=	60.91 per cent.
"	2.5.20 "	"	3.17 "	"	"	= 60.96 " "
"	3.3.12 "	"	1.90 "	"	"	= 60.85 " "
"	4.5.12 "	"	3.11 "	"	"	= 60.67 " "
"	5.5.16 "	"	3.14 "	"	"	= 60.83 " "
"	6.5.10 "	"	3.11 "	"	"	= 60.93 " "
"	7.5.10 "	"	3.09 "	"	"	= 60.61 " "
"	8.5.04 "	"	3.05 "	"	"	= 60.52 " "
"	9.5.02 "	"	3.05 "	"	"	= 60.74 " "

97.9 mg. of acetyl gave 90.1 mg. of carbon dioxide and 16.2 mg. of water; 5.10 mg. contained 3.10 mg. of iodine.

	Carbon.	Hydrogen.	Iodine.
	<i>per cent</i>	<i>per cent</i>	<i>per cent</i>
Calculated for $C_{13}H_{12}O_4NI_3$	24.88	1.93	60.77
Found.....	25.09	1.85	60.86

The Sulfate of the Acetyl Derivative.—If the acetyl derivative is dissolved in alcohol and added to boiling dilute sulfuric acid, the acetyl precipitates in free form without the addition of sulfuric acid attached to the imino group. If, however, sulfuric acid is added to the alcohol solution of the acetyl and the alcohol is evaporated either at room temperature by a current of air or by boiling under diminished pressure at a low temperature, the sulfate of the acetyl separates in needle crystals.

Analysis of the Sulfate of the Acetyl.

Sample 1.	5.02 mg.	contained	2.84 mg.	of iodine	=	56.66 per cent.
"	2.5.52 "	"	3.12 "	"	"	= 56.52 " "
"	3.6.2 "	"	3.51 "	"	"	= 56.61 " "

111.5 mg. of the sulfate of the acetyl gave 94.8 mg. of carbon dioxide and 19.7 mg. of water; 5.52 mg. contained 3.12 mg. of iodine.

	Carbon.	Hydrogen.	Iodine.
	<i>per cent</i>	<i>per cent</i>	<i>per cent</i>
Calculated for $C_{13}H_{13}O_6NI_3S_3$	23.07	1.92	56.36
Found.....	23.18	1.91	56.52

Although thyroxin is insoluble in pyridine, alcohol, ethyl acetate, or acetic acid, the acetyl is soluble in all these reagents. When the acetyl is precipitated from an alkaline solution by the addition of an acid, it is at first soluble in ether and may be extracted out of the water by placing in a separatory funnel with ether. After the acetyl has been prepared in pure form and dried, it is insoluble in ether.

*The Di-Metal Derivatives of the Acetyl.*³ -The sodium, ammonium, and potassium salts of the acetyl are prepared as with thyroxin. 100 mg. of the acetyl are dissolved in 10 cc. of alcohol, to which are added 10 cc. of 30 per cent sodium hydroxide and 5 gm. of sodium acetate. The di-metal salt will separate in large, flat crystals if the alcohol is evaporated under diminished pressure. The temperature may be raised to that of boiling water without decomposition of the acetyl by the sodium hydroxide as no hydrolysis of the acetyl occurs under these conditions. If sodium chloride is substituted for sodium acetate in a solution similar to the one mentioned above and the alcohol is evaporated, the sodium salt of thyroxin separates in small plates.

The barium and calcium salts of the acetyl are prepared by dissolving 25 to 50 mg. of the acetyl in the least possible amount of alcohol, 2 to 3 cc., adding water and $\frac{1}{2}$ to 1 cc. of pyridine; the solution is boiled until the alcohol is volatilized, care being taken not to decompose the acetyl by prolonged boiling. To the pyridine solution of the acetyl a 40 per cent solution of barium or calcium chloride is slowly added, and the solution is heated to boiling. The alkaline earth salt of the acetyl will separate. It is readily soluble in an excess of pyridine. If the solution is heated for too long a time hydrolysis will occur. The salt may be filtered and washed without decomposition.

³ In working with the acetyl, it is always necessary to dissolve the dry powder in alcohol before making it alkaline. Unless this is done, some of the acetyl will spontaneously decompose during the solution of the powder in alkali.

The reactions of thyroxin indicate that the molecule exists in both open- and closed-ring forms. The chemical properties of the acetyl are evidence that this derivative also exists in open- and closed-ring forms. The sodium salt of the acetyl washed with dilute acetic acid is completely hydrolyzed. When prepared in this way, however, its melting point is found to be 152° . When this material is dissolved in alcohol and added to boiling dilute sulfuric acid, the acetyl separates in closed-ring form, and the melting point is 238° . This suggests that in the sodium salt the acetyl exists in open-ring form, and hydrolysis of the sodium from the molecule leaves the open-ring structure. This is further corroborated by analysis of the silver salt.

Preparation of the Silver Salt of the Acetyl.—If the acetyl is dissolved in alcohol and then made alkaline with sodium hydroxide and the alcohol evaporated, the addition of ammonia and silver nitrate produces no precipitate. This is also true of thyroxin in the open-ring form. If 50 mg. of the acetyl are dissolved in 2 to 3 cc. of alcohol, to which are added 2 to 3 cc. of pyridine and 10 cc. of water, and the alcohol is removed by boiling, the addition of silver nitrate to the aqueous pyridine solution of thyroxin will cause a precipitate to form. This is not crystalline in nature, although under some conditions it may be possible to separate it in crystal form. The silver salt may be filtered on a Buchner funnel and washed with water without decomposition.

5.14 mg. of the silver salt of the acetyl contained 2.26 mg. of iodine = 44.06 per cent.

Calculated for $\text{Ag}_2\text{C}_{13}\text{H}_{12}\text{O}_5\text{NI}_3$ iodine = 44.35 per cent.

“ “ $\text{Ag C}_{13}\text{H}_{11}\text{O}_4\text{NI}_3$ “ = 51.91 “ “

The iodine content of the silver salt of the acetyl indicates the addition of 2 per cent too much silver for the disilver salt of the open-ring form of the acetyl, and 220 per cent too much silver for the mono-salt of the closed-ring form. These results, proving conclusively that not one but two atoms of silver had added to the acetyl, show that in an alkaline solution the acetyl exists in open-ring form.

The open-ring structure of the acetyl is also indicated by the increased solubility of the acetyl in weak bases such as pyridine, quinoline, and very dilute ammonia. The terminal carboxyl in

thyroxin is so weak that the acetyl derivative would not be soluble in these reagents in the closed-ring form.

Preparation of the Ureide.—Only pure thyroxin should be used in preparation of the ureide for the same reasons given under the preparation of the acetyl. 100 mg. of disodium or zinc salt of thyroxin are added to 10 to 15 cc. of glacial acetic acid containing 200 mg. of potassium cyanate. Solution of the salt of thyroxin should be completed as the ureide is soluble in acetic acid. 5 cc. of water, 5 cc. of alcohol, and 5 cc. of 50 per cent sulfuric acid are added and the alcohol, water, and acetic acid are removed under diminished pressure, the same as in the preparation of the acetyl. The sulfate of the ureide is dissolved in 15 cc. of alcohol, filtered, and slowly added to a beaker containing 200 cc. of water and 5 cc. of 50 per cent sulfuric acid, which is heated to boiling. The ureide separates in crystal rosettes or needles.

Sample 1.	4.78 mg. of ureide contained	2.91 mg. of iodine	= 60.81 per cent.
"	2. 5.04 " " "	3.07 " " "	= 61.03 " "
"	3. 5.02 " " "	3.05 " " "	= 60.74 " "
Calculated for $C_{12}H_{11}O_3N_2I_3 = 60.67$ per cent.			

Preparation of the Methyl Ester.—100 mg. of the silver salt of thyroxin are suspended in 20 cc. of alcohol to which are added 4 to 5 cc. of methyl iodide. The crystals are occasionally stirred and allowed to stand at a temperature of 40 to 50° for several hours until decomposition of the silver salt is complete. This is indicated by separation of silver iodide in voluminous form. The silver iodide is removed by filtration. If the alcohol is allowed to evaporate, the dimethyl derivative crystallizes in the form of fine threads. They may be separated by formation of the sulfate similar to the preparation of the acetyl. 5 cc. of water and 5 cc. of 50 per cent sulfuric acid are added to the alcohol filtrate from the silver iodide and the alcohol is removed by distillation under diminished pressure. The dimethyl derivative separates probably as the sulfate. It is insoluble in water, but soluble in alcohol. Treatment with alcoholic sodium hydroxide frees the carboxyl group, and the monomethyl derivative is then slightly soluble in aqueous sodium hydroxide. The methyl ester is very difficultly purified and has not been prepared containing a theoretical percentage of iodine. It appears to retain silver iodide even after repeated precipitation.

The Action of Nitrous Acid on Thyroxin.—25 mg. of thyroxin dissolved in 2 cc. of dilute sodium hydroxide were added to the deaminizing chamber of the Van Slyke apparatus, and the usual procedure was followed, shaking for 3 minutes. 0.69 cc. of nitrogen was evolved. The apparatus was allowed to stand 9 minutes and was again shaken for 3 minutes; 0.06 cc. of nitrogen was obtained. 4 minutes later it was again shaken for 3 minutes and 0.04 cc. was obtained. The total, liberated in 22 minutes, showed 1.72 per cent amino nitrogen which is 72 per cent of the total nitrogen contained in the molecule.

Another 25 mg. sample of thyroxin, after 3 minutes shaking, liberated 0.75 cc. of nitrogen. This is equivalent to 1.60 per cent of amino nitrogen in the molecule and is 67 per cent of the total nitrogen.

25 mg. of the amino carboxyl salt form of thyroxin suspended in 2 cc. after 3 minutes shaking gave 0.08 cc. 10 minutes later, after 3 minutes more shaking, 0.06 cc., and 10 minutes later, after 3 minutes shaking, 0.04 cc.; total amount liberated = 0.18 cc. which is equivalent to 0.093 mg. of amino nitrogen, and is 16 per cent of the total nitrogen. 10 mg. of keto form of thyroxin suspended in 2 cc. of water gave no amino nitrogen.

The amino nitrogen in 25 mg. of the acetyl was determined as described above. After 3 minutes 0.11 cc., and after 10½ minutes, 0.11 cc. more of nitrogen were liberated. The nitrogen in the amino form amounted to 24 per cent of the total nitrogen in the molecule.

The nitrogen in isatin and indole, given off as amino nitrogen, was determined. 100 mg. of isatin after 4 minutes gave 1.72 cc. and after 5 minutes more gave 0.41 cc. of nitrogen. This volume was equivalent to 1.13 mg. of nitrogen and amounted to 12 per cent of the total nitrogen present. 100 mg. of indole gave 1.27 cc. after 3 minutes, and 0.34 cc. of nitrogen after 4 minutes more shaking. This is equivalent to 0.86 mg. and is 7 per cent of the total nitrogen in indole.

Besides the action of nitrous acid on thyroxin liberating some of the nitrogen as amino nitrogen, a characteristic color reaction is produced. A few mg. of pure thyroxin, added to 5 cc. of alcohol containing three to four drops of 50 per cent hydrochloric to which are added five or six drops of 1 per cent sodium nitrite solution,

will develop a yellow color. This is increased by boiling. If the solution is cooled and concentrated ammonia is added until distinctly alkaline, a pink color is produced. This is a sensitive reaction for thyroxin, a distinct color being produced by one part of thyroxin in 40,000 parts of solution. If acetic or sulfuric acid is substituted for hydrochloric, the yellow color is not so deep and the addition of ammonia does not produce a pink color but gives a yellowish orange color. If the sample of thyroxin is impure, a yellow instead of a pink color is produced with ammonia. The acetyl and ureide derivatives give the same reaction, producing a pink color with ammonia.

The Pine-Splinter Reaction for Indole.—From 15 to 20 mg. of thyroxin are placed in a test-tube with 5 cc. of 30 per cent sodium hydroxide and sufficient water to carry the thyroxin into solution. As the excess of water is boiled off, thyroxin will precipitate as a disodium salt, but on further heating, after the water has been almost completely driven off and the temperature of the solution has been raised to between 100 and 200°, the disodium salt is again dissolved and a faint indole-like odor is given off. A pine-splinter moistened with hydrochloric acid is turned red by the vapors given off from the fusion.

The Effect of Thyroxin on Polarized Light.—1 gm. of thyroxin was dissolved in 20 cc. of alcohol and 7 cc. of water containing 300 mg. of sodium hydroxide. The solution was filtered and placed in a 2 dm. tube and its effect on polarized light was determined. No rotation of light could be determined. The solution of thyroxin was then placed in a 1 dm. tube. No rotation of the light could be determined.

The Effect of Hydrazine on Thyroxin.—If thyroxin is added to hydrazine hydrate, it immediately dissolves. If water is added, thyroxin remains in solution. The addition of carbon dioxide precipitates thyroxin as the amino carbonate. If the solution of thyroxin in the hydrazine hydrate is boiled after the addition of water, thyroxin precipitates as from ammoniacal solutions. No condensation with hydrazine, phenylhydrazine, semicarbazone, or hydroxylamine could be demonstrated when thyroxin was dissolved in alkaline alcohol to which these reagents were added, in acid alcohol to which these reagents were added, together with sodium carbonate or pyridine, or when dissolved in pyridine to

which the reagents were added. Either decomposed products due to heating at too high temperature or unchanged thyroxin were recovered.

The Melting Points of Thyroxin and Its Derivatives.—The following melting points of thyroxin in its several forms and its derivatives are recorded to illustrate the agreement between different samples (Tables I to IX). It is evident that among some of the derivatives fairly large variations occur, but between any two different forms the differences are much greater than that found between the melting points of two samples of the same derivatives.

The following salts of thyroxin and its derivatives were not melted when heated to 260°: di- and monosodium salt of thyroxin; di- and monopotassium salt of thyroxin; barium salt of thyroxin; disilver salt of thyroxin; disodium salt of acetyl; disilver salt of acetyl; calcium salt of acetyl.

TABLE I.
The Melting Point of the Keto Form of Thyroxin.

No. of sample.	Slight browning.	Sublime or mist.	First droplets.	Completely melted.	Froth.
125			248	250	250
32			241	248	248.9
123			235	247	247
124			240	246	246
81			243	245	246
91			241	242	243
107			241	242	242
115			239	242	242
119			239	241	241.5
117			237	241	241
97			236	240	241
28			195	240	241.5
80			239	240	240
59			238	239	240.5
51			236	239	240

TABLE II.
The Melting Point of the Enol Form of Thyroxin.

No. of sample.	Slight browning.	Sublime or mist.	First droplets.	Completely melted.	Froth.
40	190		200	202	205
41	180		200	205	205
42	190		200	204.5	204.5
43	160	190	200	204	204
44	160	190	202	208	208
46	170	190	200	202	204
49	165	190	203	206	206
50	165		196	201	201
53	150		198	203	204
55	160	190	200	202	204
108	160		198	204	205
109	180	198	206	208	208
110	170		200	202	203
111				203	205

TABLE III.
The Melting Point of the Amino Hydrate Form.

No. of sample.	Slight browning.	Sublime or mist.	First droplets.	Completely melted.	Froth.
129			214	216	216.5
114			207	212	214

TABLE IV.
The Melting Point of the Amino Carboxyl Salt Form.

No. of sample.	Slight browning.	Sublime or mist.	First droplets.	Completely melted.	Froth.
86	215		219	220	221
88			216	218	221
89			216	218	219
95			219.5	221	222
100			222	223.5	223.5
105			222	223	223.5
112			216	220	221
113			217	221	222
118			221	222	222.5
120			221	224	224
121			222	224	225
127			218	222	223
130				225.5	226

TABLE V.
The Melting Point of Acid Salts of the Amino Group.

	No. of sample.	Slight browning.	Sublime or mist.	First droplets.	Completely melted.	Froth.
Amino sulfate.....	83		182	207	208	208.5
“ “	93	162		202	204	204
“ “	103	180		206	207	208
“ oxalate.....	104	180		206	207	208
“ formate.....	101			202	205	208
“ “	76	150		190	205	206.5
“ “	84		180	202	204	204
“ “	82	160			204	205
“ acetate.....	102			202	205	208
“ carbonate.....	87	160		204	206	206

TABLE VI.
The Melting Point of the Acetyl.

No. of sample.	Slight browning.	Sublime or mist.	First droplets.	Completely melted.	Froth.
34			220	228	230
30			225	235	236
29			215	223	232

TABLE VII.
The Melting Point of the Sulfate of the Acetyl.

No. of sample.	Slight browning.	Sublime or mist.	First droplets.	Completely melted.	Froth.
27			111	150	200
25				122	190
24			100	106	150

TABLE VIII.
The Melting Point of the Acetyl in Open-Ring Form.

No. of sample.	Slight browning.	Sublime or mist.	First droplets.	Completely melted.	Froth.
8			150	160	174
35				155	155
11			146	152	216

TABLE IX.
The Melting Point of the Ureide.

No. of sample.	Slight browning.	Sublime or mist.	First droplets.	Completely melted.	Froth.
21				225	225

SUMMARY.

The most important physical and chemical properties of thyroxin may be summarized as follows:

1. Thyroxin is a colorless, odorless, crystalline substance, insoluble in aqueous solutions of all acids including carbonic. It is soluble in sodium, ammonium, and potassium hydroxides, and is very slightly soluble in sodium and potassium carbonate. Besides forming salts with metals, thyroxin also forms salts with acids.

2. The iodine content of thyroxin and the iodine content of the sulfate salt were found to be 65 and 60 per cent respectively. This established the molecular weight of 585. Ultimate analysis and a study of the derivatives of thyroxin show the structural formula to be 4, 5, 6 tri-hydro-4, 5, 6 tri-iodo,-2 oxy,-beta indolepropionic acid.

3. In the presence of alkali metal hydroxides, thyroxin forms di-basic salts through the carboxyl and hydroxy groups. In the presence of carbonates, thyroxin forms mono-basic salts with the carboxyl group alone. The imino group forms salts with mineral and formic acids but not with acetic. The salts of mineral acids are soluble in alcohol, but no acid salt of thyroxin is appreciably soluble in water. Thyroxin forms derivatives through the imino nitrogen, such as the acetyl and ureide, and through its carboxyl and hydroxy groups, such as the dimethyl derivative.

4. Thyroxin exists in four distinct forms: (1) The keto form with the imino carbonyl groups, melting point 250°; (2) the enol form in which the hydrogen migrates from the imino to the carbonyl forming the hydroxy group, melting point 204°; (3) an opening form in which the elements of water enter the molecule between the imino and carbonyl groups forming an open-ring structure with amino and carboxyl groups, which exist in salt formation, called the amino carboxyl salt form, melting point 225°; and (4) a tautomeric form of this in which the elements of water

add to the nitrogen making the amino hydrate form, melting point 216° . If an acid is added to an enol form of thyroxin, the ring opens and the acid forms an amino-acid salt. The reason why weak organic acids including carbonic can add to the nitrogen of thyroxin-forming amino salts is because the ring is unstable in neutral aqueous solutions and the nitrogen tends to exist in the pentad state adding either the elements of water and forming an amino hydrate, or adding a carboxyl and forming an amino salt. These reactions could occur only with a strongly basic group. The amino group of aniline and the imino group of indole or isatin are too feebly basic to react the same as thyroxin with weak organic acids.

5. Thyroxin is not easily oxidized or reduced, but will yield to both oxidation and reduction if sufficiently strong agents are used.

6. In alkaline solutions the iodine is broken off from the thyroxin molecule not as free iodine but as hypiodous acid. This reaction is accelerated by sunlight. Sunlight also produces pink color compounds from the colorless thyroxin molecule.

BIBLIOGRAPHY.

1. Kendall, E. C., The isolation in crystalline form of the compound containing iodine, which occurs in the thyroid, *J. Am. Med. Assn.*, 1915, lxiv, 2042.
2. Ciamician, G., and Silber, P., Ueber die Constitution der riechenden Bestandtheile des Sellerieöls, *Ber. chem. Ges.*, 1897, xxx, 1419.

CARBONIC ACID AND CARBONATES IN COW'S MILK.

BY LUCIUS L. VAN SLYKE AND JOHN C. BAKER.

(From the Chemical Laboratory of the New York Agricultural Experiment Station, Geneva.)

(Received for publication, July 26, 1919.)

The amount of carbonic acid present in cow's milk has been the subject of several investigations.¹⁻⁵ The results reported by these investigators vary from 1.84 to 7.65 per cent of CO₂ by volume. It is not necessary to review the methods which have been employed to obtain the CO₂ from milk for measurement farther than to say that they have varied from extraction by means of a vacuum pump to expulsion by heat and have been more or less open to inaccuracy; nor is it important to consider previous methods used in measuring the amount of CO₂.

The results of our work are presented under the following divisions: (I) determination of CO₂ in milk; (II) relation of pasteurized milk to CO₂; (III) the form in which CO₂ exists in milk; (IV) the tension of CO₂ in milk.

I. Determination of CO₂ in Milk.

In measuring the amount of CO₂ in milk, we have used Van Slyke's method^{6,7} in the determination of CO₂ in blood plasma, with certain modifications required to adapt the method to conditions present in milk.

¹ Hoppe, F., *Virchows Arch. path. Anat. u. Physiol.*, 1859, xvii, 417.

² Setschenow, *Z. ration. Med.*, 1861, x, 285.

³ Pflüger, E., *Arch. ges. Physiol.*, 1869, ii, 166.

⁴ Thörner, W., *Chem. Z.*, 1894, xviii, 1845.

⁵ Marshall, C. E., *Michigan Agric. Exp. Station, Special Bull. No. 16.*, 1902.

⁶ Van Slyke, D. D., *J. Biol. Chem.*, 1917, xxx, 347.

⁷ Van Slyke, D. D., and Cullen, G. E., *J. Biol. Chem.*, 1917, xxx, 291.

Our method of procedure will be described under the five heads following: (1) drawing milk from cow's udder; (2) sampling the milk drawn; (3) determination of CO_2 ; (4) results obtained with different milks; (5) determination of CO_2 in milk by exhaustion.

1. *Method of Drawing Milk.*—In order to prevent loss of CO_2 , it is of primary importance to have under complete control the method of drawing from the cow's udder the sample of milk in which CO_2 is to be measured. We have found the following method satisfactory: A silver milking-tube is inserted into the teat and the milk flows readily from the udder through this tube. To prevent the milk from coming into contact with the air, it is collected in a 100 cc. cylinder provided with a close fitting two-hole rubber stopper. Through one hole passes a glass tube extending to the bottom of the cylinder, and this tube is connected at its upper end by rubber tubing with the milking-tube. Passing through the second hole of the rubber stopper is a short glass tube which serves as an outlet for the air in the cylinder while it is being filled with milk. With this arrangement, the milk flows slowly and quietly into the cylinder without exposure to the air. The cylinder fills from the bottom upward, displacing the air until the milk fills the cylinder completely or even to slight overflowing. If desired, the surface of the milk can be protected from the air by a layer of thin paraffin oil but we have not found this necessary.

2. *Taking Sample for CO_2 Determination.*—It is essential that the samples for the determination of CO_2 be taken from the cylinder as soon as practicable after the milk is drawn from the udder, because, on standing, the rising of the fat-globules to the surface changes the composition of the different layers of milk, and also there may be diffusion of the CO_2 from the upper surface if the top of the cylinder is not entirely filled with milk. The best method of taking the sample from the cylinder is the following: One end of a 2 cc. pipette is connected to the tube leading to the bottom of the cylinder. Then one blows into the short tube, forcing the portion of milk last drawn from the udder to flow into the pipette until the milk overflows from the pipette, displacing all the air. The sample then passes from the lower part of the cylinder into the pipette without exposure to the air, without loss of CO_2 , without being subject to appreciable change

of pressure, and without disturbance of the body of the milk in the cylinder. It has been found that the portion of milk first drawn from the udder and occupying the upper portion of the cylinder does not fairly represent the CO_2 content of the entire milking.

3. *Determination of CO_2 .*—The 2 cc. sample of milk is run into the Van Slyke CO_2 apparatus. Only slight modifications are required in the method as described by Van Slyke. We find that 5 per cent sulfuric acid and other mineral acids coagulate the milk and the coagulum interferes with the operation by clogging the apparatus, making it difficult to remove the CO_2 completely from the mixture. Concentration of such acids greater than 5 per cent was also found unsatisfactory. As the result of numerous experiments with different acids and concentrations, we find that a 20 per cent solution of lactic acid obviates all difficulties and meets all requirements, dissolving the casein quickly and completely and giving the same corrections as apply to the use of 5 per cent sulfuric acid. In all our work here reported, the amount of CO_2 was determined by absorption with a 5 per cent solution of NaOH instead of making a correction for inert gases. The results are the same by either process.

4. *Results Obtained with Different Milks.*—In Table I we give the results furnished by the examination of twenty-five samples of cow's milk, drawn from the individual quarters of the udder. In addition to the amount of CO_2 in the milk, we give in each case the pH value and also the titration value expressed as cc. of alkali required to neutralize 100 cc. of milk to phenolphthalein. The results are arranged in the order of the pH values.

A study of the data embodied in Table I leads to the following statements:

1. With the increase of the value of pH, that is, with decrease of hydrogen ion concentration, there is a general tendency for the CO_2 content of the milks to increase and for the degree of acidity, as measured by titration, to decrease. This is not so marked between the pH values of 6.50 and 6.65 as it is above pH 6.65. Below pH 6.65, the CO_2 content varies between 7 and 10 per cent, while above pH 6.65 it increases somewhat uniformly from 12 at pH 6.70 to 86 at pH 7.16.

2. The acidity, as measured by titration, varies below pH 6.65 more or less irregularly between 16 and 20 cc. of 0.1 N alkali per 100 cc. of milk, while above pH 6.65, the values decrease quite uniformly from 16 down to 4 cc.

3. In comparison with the values obtained by other workers, our lowest CO₂ values are about equal to, or higher than, the highest values previously reported. Thus, the highest figure heretofore published is 7.65 per cent of CO₂ by volume, while most of our values range from 8 up to 56 per cent in milks which

TABLE I.
Amount of CO₂ in Cow's Milk.

CO ₂ (corrected) by volume.	pH value.	0.1 N alkali required to neutralize 100 cc. of milk.	CO ₂ (corrected) by volume.	pH value.	0.1 N alkali required to neutralize 100 cc. of milk.
<i>per cent</i>		<i>cc.</i>	<i>per cent</i>		<i>cc.</i>
8	6.50	19.1	9	6.62	17.2
7	6.52	20.0	10	6.63	18.0
8	6.53	18.0	10	6.65	16.6
10	6.54	16.0	12	6.70	15.4
10	6.55	17.2	12	6.80	16.0
8	6.55	18.4	18	6.82	13.0
11	6.57	17.2	14	6.86	14.0
10	6.58	17.8	22	6.90	12.0
10	6.58	16.9	33	6.92	12.0
10	6.58	18.4	24	7.00	10.0
9	6.60	18.2	56	7.05	6.0
10	6.61	16.8	86	7.16	4.0
10	6.62	17.8			

appeared by ordinary inspection to be normal. In the milks examined by us which were known to be normal, the value most frequently found is about 10 per cent. However, our work has not been sufficiently extensive as yet to enable us to indicate positively a general average figure or an average range for normal milk.

5. *Determination of CO₂ in Milk by Exhaustion.*—It was desirable to ascertain whether it is possible to remove the CO₂ completely from milk for determination simply by vacuum exhaustion. We have found that this can be done by observing certain precautions. The milk must be spread out in a thin layer during the

exhaustion. We placed 10 cc. of milk of the usual reaction (pH 6.5 to 6.65) in a 200 cc. separatory funnel and exhausted this for 2 minutes, turning the funnel end over end slowly in order to spread the milk in a thin layer over the interior surface of the funnel as completely as possible. Air was then admitted and the exhaustion repeated, after which the determination of CO_2 in the sample was made.⁸

Another portion (100 cc.) of the same milk was then placed in a 200 cc. separatory funnel and inverted. This was exhausted for 1 hour without any agitation of the milk, after which the amount of CO_2 in the sample was determined. We give the results of the two experiments in Table II.

TABLE II.
Results of Removal of CO_2 from Milk by Vacuum Exhaustion.

Original milk.		After exhaustion without agitation.		After exhaustion with agitation in a thin layer.	
pH value.	CO_2 by volume.	pH value.	CO_2 by volume.	pH value.	CO_2 by volume.
	<i>per cent</i>		<i>per cent</i>		<i>per cent</i>
6.54	10	6.57	4	6.60	0.0
6.86	14	6.92	7	6.98	0.0
6.92	22	7.00	9	7.06	0.0

These results make prominent certain points, as follows:

1. The CO_2 of milk can be completely removed by vacuum exhaustion, as shown by the results given in the last column of Table II, provided the milk is agitated and kept in a thin layer, the amount of milk used being small enough to permit control of these conditions. If the milk subjected to exhaustion is not agitated and exposed in a thin layer, the CO_2 is not completely removed, as shown by the results given in the fourth column of Table II. In previous work done by others, in which vacuum exhaustion was relied upon to remove the CO_2 from milk, the removal was incomplete, owing to failure to observe the conditions required for complete exhaustion, as in the case of the results reported by Setschenow² and by Marshall.⁵

⁸ Cullen, G. E., *J. Biol. Chem.*, 1917, xxx, 369.

2. The removal of CO_2 from milk results in an increase in the value of pH, that is, a decrease in the hydrogen ion concentration or, stated in another way, the milk becomes less acid, though to an amount that cannot be made appreciable by titration in normal milks. In the first sample in Table II, the original milk, containing 10 per cent by volume of CO_2 has a pH value of 6.54, which increases to 6.57 when the CO_2 is reduced to 4 per cent, and which increases farther to pH 6.60 when the CO_2 is completely removed.

II. Relation of Pasteurized Milk to CO_2 .

The observation stated in the preceding paragraph led us to make a study of some results which we had obtained in another investigation relating to the effect of pasteurization upon the reaction of milk. We had noticed that pasteurization, if properly performed, is without observable effect in changing the hydrogen ion concentration of milk. Our experiment was repeated with the modification that the CO_2 was completely removed from the milk by exhaustion before heating. The two experiments gave results as recorded in Table III.

TABLE III.

Effect of Removal of CO_2 on Reaction of Pasteurized Milk:

Before removal of CO_2 .				After removal of CO_2 .			
Before heating.		After heating at 63°C. for 15 min.		Before heating.		After heating at 63°C. for 15 min.	
pH value.	CO_2 by volume.	pH value.	CO_2 by volume.	pH value.	CO_2 by volume.	pH value.	CO_2 by volume.
	<i>per cent</i>		<i>per cent</i>		<i>per cent</i>		<i>per cent</i>
6.54	10	6.54	2	6.60	0	6.56	0

In studying the results of these two experiments, we notice:

1. In the milk in which CO_2 is not removed before heating, the pH value remains the same before and after heating, even though the per cent of CO_2 is decreased by the heating from 10 to 2 per cent.

2. In the milk in which CO_2 is completely removed by exhaustion before heating, the pH value decreases from 6.60 to 6.56, that is, the hydrogen ion concentration increases appreciably.

3. We have not yet carried our work far enough to furnish an explanation of the fact noted, but the inference appears justified that some chemical change occurs in the milk during pasteurization which results in an increase of hydrogen ion concentration, when CO_2 is absent, but that in the presence of CO_2 any change in the hydrogen ion concentration is, in some way not yet known, masked or offset by the loss of CO_2 which escapes from the milk during heating.

4. The decrease of CO_2 in pasteurized milk suggests that the CO_2 content of milk might be made the basis of a method for distinguishing pasteurized from normal milk. We are doing additional work in order to determine the limits of effectiveness of such a method.

III. Form in which CO_2 Exists in Milk.

It has been generally assumed that CO_2 exists in milk as uncombined carbonic acid. From the fact that the reaction of milk is less acid than that given by a corresponding solution of CO_2 in water, it appears probable that the CO_2 in milk is present in part as carbonic acid and in part as bicarbonate. To determine the proportion of CO_2 existing in milk as carbonic acid and as bicarbonate, two methods are available; (1) by calculation based on the application of the law of mass action, and (2) by direct determination. The results obtained by either of these methods can be regarded as only approximate, owing to the high dilution of CO_2 in milk.

1. *Calculation Based on Application of the Law of Mass Action.*—In a solution containing H_2CO_3 and RHCO_3 , there exist in accordance with the law of mass action definite quantitative relations between the hydrogen ion concentration of the solution and the relative amounts of H_2CO_3 . These relations are expressed by the following equations:

$$C_{\text{H}} = K \frac{\text{H}_2\text{CO}_3}{\text{CO}_3} = K \frac{\text{H}_2\text{CO}_3}{\alpha \text{RHCO}_3},$$

in which α is the degree of dissociation of RHCO_3 into R^+ and HCO_3 , and K is the ionization constant of H_2CO_3 . From the foregoing, we have $\frac{\text{H}_2\text{CO}_3}{\text{RHCO}_3} = \frac{\alpha C_{\text{H}}}{K}$. Therefore, to determine the ratio

between bicarbonate and carbonic acid, we need only to know the values of K , C_{II} , and α for $\text{RHC}'\text{O}_3$ (as NaHCO_3). According to Michaelis and Rona,⁹ K equals 4.4×10^{-7} ; the C_{II} value of average milk is about 0.25×10^{-6} ; the value of α is difficult to determine with more than an approximate degree of accuracy under the conditions present in milk, but by a method similar to that of Michaelis and Rona, we obtain a value which makes the ionization of the bicarbonate in milk about 80 per cent.

Applying these values in the equation, $\frac{\text{H}_2\text{CO}_3}{\text{RHC}'\text{O}_3} = \frac{\alpha C_{II}}{K}$ we have

$$\frac{0.80 \times 0.25 \times 10^{-6}}{4.4 \times 10^{-7}} = \frac{10}{22}$$

This result means that the CO_2 exists in milk in approximately the relation of one part of H_2CO_3 for two parts of bicarbonate, or that one-third of the CO_2 exists as H_2CO_3 and two-thirds as bicarbonate.

2. *Proportion of Bicarbonate Acid and Bicarbonate Determined by Experiment.*—The second method of ascertaining the proportion of CO_2 in milk present as carbonic acid and bicarbonate is based on the isohydric principle. A solution of carbonate containing a molecular concentration equal to that of milk would, if adjusted to the same hydrogen ion concentration, have approximately the same relative proportions of carbonic acid and bicarbonate. Milk is approximately a 0.01 N solution of H_2CO_3 . In carrying out the details of our experiment, we dilute 10 cc. of a 0.1 N solution of Na_2CO_3 to 100 cc. with water free from CO_2 . Then we add a solution of 0.1 N HCl until the reaction is the same as that commonly found in milk (C_{II} , 0.25×10^{-6}). This requires 6.6 cc. of the acid. Of the 6.6 cc. of the 0.1 N HCl thus required 5 cc. are used to change Na_2CO_3 into NaHCO_3 , leaving 1.6 cc. of 0.1 N HCl to act upon the NaHCO_3 and form H_2CO_3 . In changing the 100 cc. of 0.01 N Na_2CO_3 solution into NaHCO_3 , the resulting 100 cc. of 0.01 N NaHCO_3 has only one-half the neutralizing power of the Na_2CO_3 solution. Therefore, 1.6 cc. of 0.1 N HCl neutralizes 3.2 cc. of the 100 cc. of 0.01 N NaHCO_3 solution, forming 32 cc. of 0.01 N H_2CO_3 and leaving 68 cc. of 0.01 N NaHCO_3 . These results furnish the ratio, 32 H_2CO_3 : 68 NaHCO_3 , or, approximately, the ratio of 1 : 2 ; that is, one-third

⁹ Michaelis, L., and Rona, P., *Biochem. Z.*, 1914, lxxvii, 182.

part of the CO_2 exists in the solution as H_2CO_3 and two-thirds as NaHCO_3 , a result which is in close agreement with that obtained by application of the law of mass action.

In this connection it is interesting to note that Marshall⁵ states that CO_2 is not completely removed from milk by his method of vacuum exhaustion, owing, as he seems to think, to a slow generation of CO_2 in the milk. This is readily explained by the presence of bicarbonate in milk, which gradually gives up its CO_2 under reduced pressure as a result of the reaction of bicarbonate with some of the salts contained in milk.

IV. *The CO_2 Tension in Milk.*

The CO_2 tension in milk is about the same as in most fluids of the animal body. Using McClendon's chart¹⁰ we find by extrapolation of values that the CO_2 tension at 20°C . of a 0.01 N solution, pH 6.6, is approximately equal to 50 to 55 mm. of mercury. It is a matter of interest to notice that the CO_2 tension of blood under the conditions is given by him as 47 mm. Comparing this with the value for milk, one would expect a lower value in blood, because the latter is exposed to air in the lungs and, therefore, subject to loss of CO_2 by removal.

SUMMARY.

1. Milk is drawn from the cow's udder into a 100 cc. cylinder so as to fill the cylinder from the bottom upward, thus avoiding mixture with air or loss of CO_2 . For the determination of CO_2 , 2 cc. of milk are forced from the cylinder into the Van Slyke CO_2 apparatus without loss of CO_2 . A 20 per cent solution of lactic acid is used to free the CO_2 in carbonates.

2. In the case of twenty-five samples of milk drawn from separate quarters of the udder, the CO_2 varies from 7 per cent by volume to 86 per cent; the pH value varies from 6.50 to 7.16, in a general way increasing with the CO_2 content; the degree of acidity, as measured by titration, tends to decrease with increase of CO_2 content. In comparison with the results of other workers, the results obtained by us are higher. The CO_2 content of normal milk appears to be about 10 per cent by volume.

¹⁰ McClendon, J. F., *J. Biol. Chem.*, 1917, xxx, 274.

3. It is possible to remove CO_2 from milk completely by vacuum exhaustion provided the milk is spread in a thin layer and kept in motion.

4. When milk is pasteurized, the CO_2 content is decreased, but the pH value remains unchanged. However, if the CO_2 is completely removed before pasteurization, then the pH value appears to decrease slightly after pasteurization.

5. CO_2 exists in milk as H_2CO_3 and as bicarbonate, probably NaHCO_3 , the ratio being about one part of H_2CO_3 and two parts of NaHCO_3 .

6. The CO_2 tension in milk is calculated to be about equal to 50 to 55 mm. of mercury at 20°C . in case of a 0.01 N solution with a pH value of 6.60.

CONDITIONS CAUSING VARIATION IN THE REACTION OF FRESHLY-DRAWN MILK.

BY LUCIUS L. VAN SLYKE AND JOHN C. BAKER.

(From the Chemical Laboratory of the New York Agricultural Experiment Station, Geneva.)

(Received for publication, July 26, 1919.)

The most sensitive method of measuring the reaction of milk is by measurement of the hydrogen ion concentration. This method has been employed by several investigators¹⁻⁷ in connection with the study of milk and it has been utilized in the work here presented.

The results of previous investigations show cow's milk, when freshly drawn, to have a reaction, expressed in terms of pH values, varying from 6.39 to 6.81, the range in most cases being between 6.50 and 6.65.

It appeared to us desirable to ascertain the extent of variation in large numbers of milks obtained directly from cows and to learn further, if possible, the causes of such differences. The results of our work will be discussed under the following headings: (1) Extent of variation of reaction in cow's milk, (2) variation in different quarters of the udder, (3) relation of reaction of milk to composition, (4) effect of abnormal conditions in the udder.

Extent of Variation of Reaction in Cow's Milk.

In undertaking to establish in our own experience the extent to which the reaction of fresh milk varies, we measured the hydrogen ion concentration in over 300 samples obtained from two herds of

¹ van Dam, W., *Rev. gén. Lait*, 1908, vii, 121.

² Allemann, O., *Biochem. Z.*, 1912, lxxv, 346.

³ Taylor, H. B., *J. Proc. Roy. Soc. N. S. Wales*, 1913, lxxvii, pt. 2, 174.

⁴ Davidsohn, H., *Z. Kinderheilk.*, 1913, ix, 14.

⁵ Clark, W. M., *J. Med. Research*, 1914-15, xxxi, 431.

⁶ Milroy, T. H., *Pharmacol. J.*, 1914, xciii, 350.

⁷ Foa, C., *Compt. rend. Soc. biol.*, 1904, lix, 51.

cows; one was a herd of Jerseys and the other of Holstein-Friesians. The samples used in our work were drawn separately from the individual quarters of the udder and the reaction was determined in each. In obtaining the samples, the first few streams of milk were thrown away and then enough more was drawn for use in our experiments. The results do not, therefore, represent the complete milking of the entire udder but only the foremilk of each quarter of the udder. The use of milk from individual quarters of the udder gives a greater variation in results than would be found if we used only samples representing the mixed milk of a complete milking of the entire udder. The use of the foremilk is very convenient for our purpose and is justifiable, since in our experience the reaction rarely changes appreciably in normal milks in portions successively drawn during milking, provided there is no excessive disturbance of the udder.

In Table I we give summarized results of our work with over 300 samples of milk, the reaction being stated in terms of pH values.

TABLE I.

		pH 6.50 to 6.60.	pH 6.60 to 6.68.	pH 6.68 to 6.76.	pH 6.76 to 6.84.	pH 6.84 to 6.92.	pH 6.92 to 7.00.	pH 7.00 to 7.20.	Total number of samples.
Herd 1..	Number of samples.	78	35	23	7	6	2	2	153
	Per cent of total.	51	22.9	15	4.6	3.9	1.3	1.3	—
Herd 2..	Number of samples.	61	32	27	15	9	6	5	155
	Per cent of total.	39.4	20.6	17.4	9.7	5.8	3.9	3.2	—

The samples of milk from the two herds of cows show quite as wide a range of hydrogen ion concentration as we have found in our entire experience up to the present time, working with a great variety of milks, though it is probable that somewhat wider variations may occur. Our results indicate that the reaction of fresh normal milk, expressed in terms of pH values, lies between 6.50 and 6.75 or 6.80. In Herd 1, 136 samples, or nearly 90 per cent of all the samples, and in Herd 2, 120 samples, or over 77 per cent, are below pH 6.76, that is, an average of 83 per cent of all

the samples examined for these two herds. These figures are in agreement with results previously published, except that we find a small proportion of milks which are less acid, the pH values reaching as high as 7.2. We usually find that milks of such abnormally low acidity are sufficiently normal in appearance to pass the ordinary methods of market inspection when mixed in the commercial supply with other milks that are normal. The wide range of values obtained by us is doubtless due to the fact that the samples of milk used in our work represent individual quarters of the udder and not the complete mixed milk drawn from the entire udder at one milking. The mixed milk of a herd shows still smaller variation than that from single cows.

Variation of the Reaction of Milk in Different Quarters of the Udder.

It is a matter of interest to show at this point to what extent milk drawn from different quarters of a cow's udder may vary in reaction. In Table II we give results obtained with twenty cows. The hydrogen ion concentration in these samples was determined approximately by means of brom-cresol purple used as an indicator, as described on page 364. The results are given in two forms. The range of pH values from 6.50 to values above 7 is divided into seven groups, indicated by number, and after each such group number there is given in parenthesis the corresponding range of specific values.

A study of the tabulated data suggests the following points of interest.

1. The reaction found to be the more common is that showing the higher acidity. Out of the 80 samples of milk drawn from the quarters of the udders of the twenty cows used in the work, 39, or nearly 50 per cent, are in Group 1, showing the highest acid reaction (pH 6.50 to 6.60); 21, or over 26 per cent, are in Group 2 (pH 6.60 to 6.68); 14, or over 17 per cent, are in Group 3 (pH 6.68 to 6.76); these three groups contain 92.5 per cent of the total. Group 4 (pH 6.76 to 6.84) contains three samples, while the least acid groups, 5, 6, and 7, contain only one sample each.

2. These results indicate that the hydrogen ion concentration of normal mixed milk, when fresh, is that representing the most

acid reaction found by us (pH 6.50 to 6.60), the variations being in the direction of decreased acidity.

3. Comparing the different quarters of the udder in individual cows, we find that there are only four (Nos. 16, 19, 20, 14) in which the reaction is the same in all quarters; and in these cases the re-

TABLE II.

Results Showing Variation in Reaction of Milk Drawn from Different Quarters of Udder.

Cow No.	Quarter of udder.							
	Right front.		Left front.		Right hind.		Left hind.	
	Group.	pH	Group.	pH	Group.	pH	Group.	pH
16	1	(6.50-6.60)	1	(6.50-6.60)	1	(6.50-6.60)	1	(6.50-6.60)
19	1	" "	1	" "	1	" "	1	" "
20	1	" "	1	" "	1	" "	1	" "
14	2	(6.60-6.68)	2	(6.60-6.68)	2	(6.60-6.68)	2	(6.60-6.68)
2	2	" "	1	(6.50-6.60)	1	(6.50-6.60)	1	(6.50-6.60)
13	1	(6.50-6.60)	2	(6.60-6.68)	1	" "	1	" "
15	1	" "	3	(6.68-6.76)	1	" "	1	" "
10	3	(6.68-6.76)	2	(6.60-6.68)	2	(6.60-6.68)	2	(6.60-6.68)
12	5	(6.84-6.92)	3	(6.68-6.76)	3	(6.68-6.76)	3	(6.68-6.76)
1	2	(6.60-6.68)	2	(6.60-6.68)	1	(6.50-6.60)	1	(6.50-6.60)
5	2	" "	1	(6.50-6.60)	1	" "	2	(6.60-6.68)
9	3	(6.68-6.76)	3	(6.68-6.76)	1	" "	1	(6.50-6.60)
4	1	(6.50-6.60)	1	(6.50-6.60)	2	(6.60-6.68)	3	(6.68-6.76)
8	2	(6.60-6.68)	2	(6.60-6.68)	1	(6.50-6.60)	3	(6.68-6.76)
6	2	" "	3	(6.68-6.76)	1	" "	2	(6.60-6.68)
17	3	(6.68-6.76)	2	(6.60-6.68)	3	(6.68-6.76)	1	(6.50-6.60)
11	4	(6.76-6.84)	1	(6.50-6.60)	3	(6.68-6.76)	1	" "
18	1	(6.50-6.60)	1	" "	4	(6.76-6.84)	3	(6.68-6.76)
7	2	(6.60-6.68)	1	" "	1	(6.50-6.60)	6	(6.92-7.00)
3	1	(6.50-6.60)	2	(6.60-6.68)	7	(7.00-7.20)	4	(6.76-6.84)

action is that of the most acid groups, 1 and 2. In another examination of the same twenty cows, ten individuals were found to give a uniform reaction in the milk from all quarters, eight showing pH 6.50 to 6.60 and two, pH 6.60 to 6.68. In Table II the milk of only five animals (Nos. 12, 11, 18, 7, 3) departs markedly from the normal reaction, and in these cases the ab-

normal condition appears in only six of the twenty individual quarters.

4. While it is not the purpose of this article to discuss in detail the causes of these observed variations in reaction in the milk from the different quarters of the udder, we may state in passing that such variations must be due to some physiological condition of the animal, either a specific bacterial infection of the udder or a more general constitutional condition, such as variation in base and acid relations in the blood stream.

Relation of the Reaction of Milk to Composition.

Attention has been called to the fact that the reaction most commonly prevalent in freshly-drawn milk is the one that is most acid, and that the variation is all in the direction of decreased acidity; and, further, that the number of samples in which the acidity decreases is found to fall off rapidly with the greater decrease of acidity.

It was desired to ascertain, if possible, some of the conditions under which decrease of acidity occurs. Our attention was first turned to a study of possible relations that might exist between changes in reaction and changes in composition of milk. We made analyses of several samples of freshly-drawn milk in the case of cows which had previously been found to give milk varying noticeably in reaction from normal. Each sample of milk was drawn from one quarter of the udder, the entire contents being drawn, except in certain cases to which attention is called. All the samples were from cows whose milk was going into the local market supply. There was nothing abnormal that was observable in the appearance of the milk or of the cows, except that the milk with the least acid reaction had the characteristic bluish appearance of what we commonly call "thin" or "poor" milk.

The results are given in Table III, the analyses being arranged in the order of pH values, beginning with the most acid.

An examination of the data in Table III suggests that there are certain points of correspondence between the reaction of milk and the composition.

We observe that, with a decrease of acidity, there is a marked tendency toward a decrease in the specific gravity and in the per-

centage of total solids, fat, solids-not-fat, casein, and sugar; but, on the other hand, an increase in albumin and proteins other than casein, and in the ash and also in the chlorine. There is, further, as we have shown in another article (p. 338) an increase in CO₂ content with decrease of acidity.

TABLE III.

Results Showing Reaction of Milk in Relation to Composition.

Cow No.	pH value.	Total solids.	Fat.	Total proteins.	Casein.	Proteins other than casein.	Sugar.	Ash.	Chlorine.	Specific gravity.
		<i>per cent</i>	<i>per cent</i>	<i>per cent</i>	<i>per cent</i>	<i>per cent</i>	<i>per cent</i>	<i>per cent</i>	<i>per cent</i>	
1	6.53	12.81	4.50	3.21	2.55	0.66	4.60	0.70	0.09	1.029
2	6.56	12.07	3.60	3.32	2.56	0.76	4.60	0.65	0.12	1.031
3	6.58	14.57	5.40	3.60	2.75	0.85	5.10	0.72	0.10	1.032
4*	6.60	13.30	3.80	3.31	2.62	0.69	5.20	0.69	0.11	1.030
5	6.70	12.10	3.60	3.21	2.50	0.71	4.40	0.86	0.13	1.030
6†	6.80	13.29	4.30	4.49	2.84	1.65	3.70	0.71	0.14	1.028
7	6.85	13.74	5.40	3.00	2.20	0.80	4.50	0.81	0.14	1.030
8	6.91	9.41	1.20	3.02	2.05	0.97	4.16	0.79	0.14	1.030
9	6.95	10.58	2.40	3.14	2.05	1.09	3.80	0.83	0.16	1.030
10	6.96	10.48	3.40	2.45	1.69	0.76	3.80	0.83	0.14	1.026
11	6.98	10.41	2.80	2.80	1.79	1.01	4.00	0.81	0.15	1.027
12‡	7.00	12.42	5.65	2.73	1.63	1.10	3.20	0.84	0.18	1.022
13	7.04	10.10	2.20	3.23	2.26	0.97	3.70	0.84	0.16	1.030
14*	7.06	8.85	2.80	2.64	1.50	1.14	2.60	0.91	0.22	1.021
15	7.15	9.13	2.10	3.14	1.71	1.43	3.00	0.89	0.21	1.026

* The sample was the last portion of milk drawn from the udder (strippings).

† The sample was from a cow in the last stage of lactation, being nearly "dry."

‡ The sample was from a cow just beginning the period of lactation, or "fresh in milk."

These findings raise the question as to whether there is any reason for the correspondence existing between the observed changes in reaction and composition. These changes are such as would be expected, if we were to add blood-serum or lymph to normal milk and they are also in agreement with the results re-

ported by others⁸⁻¹⁶ who have worked with milk from diseased udders, though our samples were from udders which were apparently in normal condition.

This phase of the question brings us to a consideration of abnormal conditions of the udder in relation to the reaction of milk.

The Reaction of Milk in Relation to the Presence of Leucocytes and Bacteria in the Udder.

All the samples of milks used by us were from udders which were apparently in a condition of normal health under casual observation; but a special examination of those samples (Table III) showing a reaction indicated by pH values above 6.70 was made for leucocytes and streptococci. For the work done in making these examinations, we are under obligation to Miss Mildred C. Davis, City Bacteriologist of Geneva. Use was made of Breed's¹⁷ method of direct-counting in the milk. The results of the work are given in Table IV.

The results in Table IV indicate in a general way that decreased acidity in fresh milk is related to infection of the udder. Decrease of acidity is shown to be associated with increase of leucocytes, provided acid-producing streptococci are not present in sufficient numbers to neutralize such effect. Thus, in No. 7, we have a milk not far from normal in reaction, even though it contains a large number of leucocytes (20 million per cc.), a number which in Samples 14 and 15 gives a marked relative decrease in acid reaction; but this condition in No. 7 appears to be accounted for by the relatively large number of acid-producing streptococci (1 million per cc.), the acid produced offsetting the decrease of acidity caused by leucocytes.

⁸ Storch, V., *Jahresb. Thierchem.*, 1884, xiv, 170; 1889, xix, 157.

⁹ Hoyberg, H. M., *Z. Fleisch.-u. Milchhyg.*, 1911, xxi, 1.

¹⁰ Fetzer, L. W., *Eighth Internat. Cong. Applied Chem.*, 1912, xix, 111.

¹¹ Chrétien, M., *Hyg. viande et lait*, 1912, vi, 382.

¹² Allemann, O., *Milkwirtsch. Centr.*, 1915, xlv, 122.

¹³ Zaribnicky, F., *Arch. wissenschaft. u. prakt. tierheilk.*, 1913-14, xl, 355.

¹⁴ Henderson, J. B., and Meston, L. A., *Chem. News*, 1914, cx, 275, 283; 1915, cxi, 51.

¹⁵ Bahr, L., *Z. Fleisch.-u. Milchhyg.*, 1913-14, xxiv, 251, 288, 370, 398, 472.

¹⁶ Foa, C., *Compt. rend. Soc. biol.*, 1905, lix, 51.

¹⁷ Breed, R. S., *New York Agric. Exp. Station, Techn. Bull.* 49, 1916.

Reaction of Milk

TABLE IV.

Relation of Leucocytes and Streptococci to the Reaction of Milk.

Cow No.	pH value.	No. of leucocytes per cc.	No. of streptococci per cc.
		<i>millions</i>	<i>millions</i>
6	6.80	1	0.1
7	6.85	20	1.0
8	6.91	3	Small number.
9	6.95	5	" "
10	6.96	10	" "
11	6.98	8.4	" "
12	7.00	4	0.2
13	7.04	3	Small number.
14	7.06	20	0.5
15	7.15	21	0.3

A further study was made of five samples of milk in which the approximate pH value was determined by means of brom-cresol purple used as an indicator, the microscopic examination for leucocytes and streptococci being made by Miss Davis. The results are given in Table V.

TABLE V.

Results of Examination of Milk for Leucocytes and Streptococci.

Sample No.	Approximate pH value.	Cells.	Acid production.
1	6.68-6.76	Many leucocytes. Streptococci, innumerable and in clumps at bottom of tube.	Marked acid production by clumps at bottom of tube within 1 hour after milking.
2	6.72-6.80	5 million leucocytes per cc. Streptococci, innumerable, separate, and in clumps.	Marked acid production by clumps at bottom of tube within 30 minutes after milking.
3	6.76-6.84	Many leucocytes. Streptococci, innumerable, separate, and in clumps at bottom of tube.	Marked acid production by clumps at bottom of tube within 30 minutes after milking.
4	Over 7.00	Leucocytes, innumerable; few streptococci.	No acid production apparent.
5	" 7.00	Leucocytes, innumerable; few streptococci.	No acid production apparent.

Summarizing the results embodied in Table V, we notice:

1. In Samples 4 and 5, containing innumerable leucocytes and showing evidence of the presence of garget, there were few streptococci and the acidity was lowest. On standing a few hours, these samples furnished no evidence of increase of acidity.

2. In Samples 1, 2, and 3, which were the more acid ones, there were immense numbers of streptococci, especially in clumps; and while there were also many leucocytes, there was an increase of acidity within a very short time after the milk was drawn from the udder.

3. It appears highly probable that the greater acidity in the milks containing enormous numbers of streptococci is due to the formation of acid by these organisms, especially in view of the fact that milk from diseased udders, containing large numbers of leucocytes with few streptococci, shows the lowest degree of acidity found in fresh milk. In other words, we find milks that contain large numbers of leucocytes and are abnormally low in acidity when streptococci are present in only small numbers or entirely absent usually show appreciably higher acidity when streptococci are present in large numbers.

A Suggested Explanation of the Decreased Acidity in Abnormal Milks.

We have already stated that the correspondence existing between the observed changes in reaction and composition of milk may be accounted for on the supposition that the change in the direction of decreased acidity is due to the presence of blood-serum or lymph. Decrease of acidity in fresh milk is observed in case of diseased udders and may, therefore, be due to the direct filtration of blood-serum or lymph into the lumen of the alveoli without transformation by the gland cells or through lesions caused by bacterial activity. This view harmonizes with several facts. (1) It is in harmony with the changes in composition of the milk; (2) it is in agreement with the hydrogen ion concentration shown by normal milk (pH 6.50 to 6.60), and that shown by blood-serum (about pH 7.60); (3) it harmonizes with the variation found by us in the CO₂ content of milk, normal milk containing about 10 per cent by volume and blood-serum, 65 per cent; and (4) it is in agreement with the increasing number of leucocytes found in the less acid milks.

Further proof of the presence of blood-serum or lymph in most of the abnormal milks (pH 6.90 to 7.20) examined by us is the existence of fibrin in such samples, as shown by Doane's method.¹⁸

Another method of proof was undertaken, which was to ascertain if glucose is present in the abnormal milks under discussion. If serum passes unchanged into milk, glucose should be present in such abnormal samples in appreciable amount. We were, however, unable in any case to find the slightest trace of glucose in these abnormal milks. If glucose is absent from the serum present in these milks, the glucose in the blood-serum must be changed into another compound by some agent present in the milk in the udder, which might be udder cells or some enzyme. The question calls for further investigation.

The method used by us for the detection of glucose is the following: Proteins are precipitated by 70 per cent alcohol and the filtrate evaporated to dryness. This residue is extracted first with ether and then with hot 95 per cent alcohol. The alcoholic extract is evaporated to dryness and the residue again extracted and the extract evaporated to dryness, after which the residue is extracted with a small amount of ether. This residue is used for the osazone test. Glucose added to milk can be recovered easily by this method.

SUMMARY.

1. The object of the investigation was the study of the extent and causes of the variation of the hydrogen ion concentration in freshly-drawn cow's milk.

2. In the case of over 300 samples of fresh milk, the pH value varied from 6.50 to 7.20, being under 6.76 in 80 per cent of the samples.

3. In the case of the milk from 20 cows, it was found that the pH value of the milk from different quarters of the udder varied greatly but in most cases the variations were not large.

4. The pH value is found to vary with the composition of the milk. In general, with a decrease of acidity, there is a marked tendency toward a decrease in specific gravity, and in percentage of fat, total solids, solids-not-fat, casein, and lactose, but an increase in proteins other than casein and in ash and chlorine.

¹⁸ Doane, C. F., *Maryland Agric. Exp. Station, Bull. 102, 1905.*

5. These changes in composition are such as would be expected in case blood-serum or lymph were added to normal fresh milk. Abnormal conditions in the udder might cause such addition.

6. Examination of milks of abnormally low acidity, having a pH value above 6.80, indicates that the reaction is accompanied by the presence of large numbers of leucocytes, though the reaction in such cases may be neutralized by the presence of large numbers of acid-producing streptococci.

7. While the belief in the presence of blood-serum or lymph in such milk is supported by several considerations, a careful test for glucose proved negative.

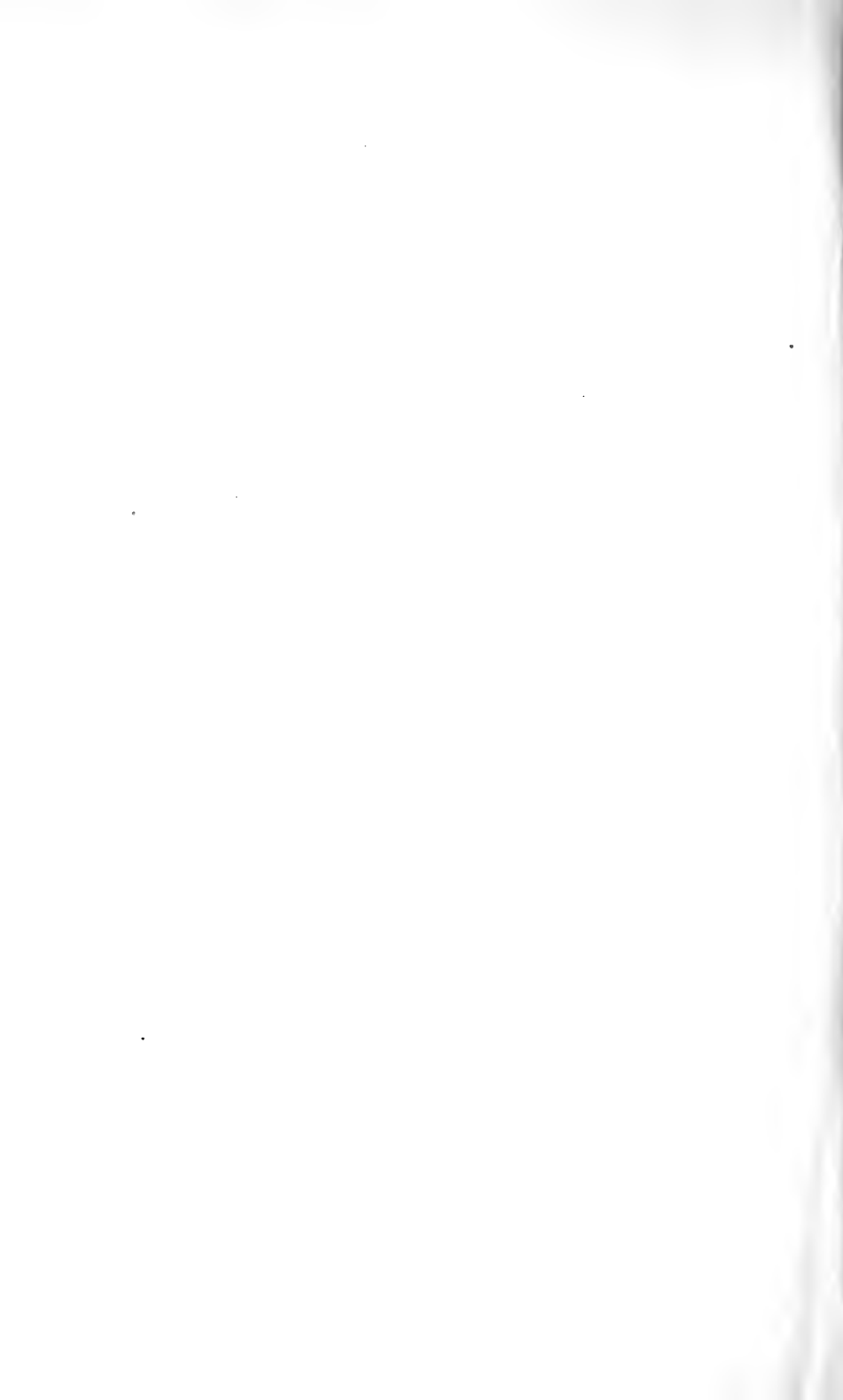

A METHOD FOR THE PRELIMINARY DETECTION OF ABNORMAL MILK BASED ON THE HYDROGEN ION CONCENTRATION.

BY JOHN C. BAKER AND LUCIUS L. VAN SLYKE.

*(From the Chemical Laboratory of the New York Agricultural Experiment
Station, Geneva.)*

(Received for publication, October 8, 1919.)

INTRODUCTION.

In the official inspection of market milk, the primary object is to detect samples that are abnormal in composition as well as in sanitary character. The full examination of a large number of samples for the purpose of detecting an occasional abnormal one involves a relatively large amount of inefficiency in attaining the object. Attempts have been made to minimize the labor of inspection by using some quick and simple method which would serve the purpose of enabling one to detect suspicious samples; and only those samples which showed some evidence of abnormality by such preliminary test would be selected for further detailed examination in the laboratory, in order to confirm or disprove the suspicion. In examining market milk for the purpose of quickly identifying abnormal samples, inspectors have been limited in their methods to the use of the hydrometer or lactometer, except that in some cases the senses of smell, taste, and sight could also be employed to advantage. The determination of the specific gravity of milk has found its chief use in enabling one to select samples which appear to give evidence of being watered or skimmed. It has been repeatedly shown that specific gravity as a basis for accurate judgment in identifying abnormal milks may be wholly misleading. The need of a more comprehensive and reliable method has long been realized.

The Relation of Hydrogen Ion Concentration to Normal and Abnormal Milks.

In making a study of the hydrogen ion concentration of freshly-drawn milks, normal and abnormal, and also of normal milks subjected to various conditions of change, it was found that the hydrogen ion concentration is very sensitive to certain conditions, among which are (1) production of acid by bacteria, (2) the addition of formaldehyde solution, (3) the addition of acids, (4) heating above a certain temperature, (5) abnormal or diseased milks, (6) addition of water, (7) addition of alkali or alkaline salts, (8) removal of fat. The first four conditions increase the hydrogen ion concentration, that is, render the reaction of the milk more acid than normal, while the other conditions render the reaction of the milk less acid than normal.

It occurred to us that, if it were possible to obtain an indicator having a neutral point near that of normal milk and yet showing an appreciable color in normal milk, which would be sufficiently sensitive to show observable change of color with slight change of hydrogen ion concentration, such an indicator might find application as the basis of a method to be used for the purpose of quickly indicating the probability of normality or abnormality in a milk. The first suggestion of an indicator meeting these conditions came to us in connection with the work published by Clark and Lubs¹ on "A substitute for litmus for use in milk cultures." They made use of a dye, known as dibrom-ortho-cresol-sulfon-phthalein, the name being shortened for convenience to "brom-cresol purple." This dye was found by them to possess properties which make it a reliable and brilliant indicator for the colorimetric determination of hydrogen ion concentration in milk.²

We first made use of brom-cresol purple in testing its applicability to the detection of increased acidity in milk when formed by bacterial action, and found that it is extremely sensitive in comparison with phenolphthalein, which is the indicator in common use in titration for the determination of the degree of acidity

¹ Clark, W. M., and Lubs, H. A., *J. Agric. Research*, 1917, x, 105.

² This dye can be purchased from Hynson, Wescott, and Dunning, Baltimore, Md. In ordering this dye the full name should be used.

in milk. Further extension of the use of brom-cresol purple demonstrated its practicability in detecting other conditions, especially those mentioned above.

OUTLINE OF PROPOSED METHOD.

Before describing the detailed operation of the method, we will give a brief statement, outlining its main features. The use of brom-cresol purple in this application to the preliminary detection of abnormal milks consists in adding to one drop of a saturated water solution of the dye 3 cc. of milk and then observing the color. In the case of average milks that are normal in character, such, for example, as good market milk, the color is very uniform, being a bluish-gray. In the case of a milk giving a color differing appreciably from this, there is ground for suspicion that it is not normal. The color given by different milks may be lighter or darker, ranging from a bright yellow at one extreme to a deep blue at the other. *The color is made lighter by acids, acid salts, formaldehyde solution, and also by heating above the usual point of pasteurization. The color becomes deeper blue in the case of milk from diseased udders, watered milk, skimmed milk, and milk containing added alkali or an alkaline salt.*

If a preliminary test with brom-cresol purple gives a color lighter than in the case of normal milk, then a sample can be taken by the inspector to be used in making a further detailed examination in the laboratory for acidity, formaldehyde, and overheating. If the color is darker than normal, then a sample is taken to ascertain whether the abnormality is due to the addition of water, alkaline salts, removal of fat, or to the presence of milk from a diseased udder.

Attention should be called here to some conditions which modify the characteristic color given by brom-cresol purple solution with average normal milk.

1. *Effect of High Percentage of Milk-Fat.*—The presence of extra fat, as in the case of rich milks (5 per cent or more) gives an appreciably lighter color than in the case of the ordinary market milks containing 3 to 4 per cent of milk-fat.

2. *Effect of High-Colored Milk.* In the case of milks produced by cows at fresh pasture, the milk has a decided yellow color which modifies the color reaction with brom-cresol purple.

3. *Effect of the Removal of Milk-Fat.*— When fat is removed from milk, the resulting skim-milk gives with brom-cresol purple a darker color than does the same milk before the removal of fat.

These differences in color are due to the fact the fat-globules do not give the same reaction color as normal milk with brom-cresol purple and they thus modify by their presence the color of the indicator in the milk. The fat dissolves some of the dye which always appears yellow in the fat. The effect of milk-fat upon the reaction color can be readily observed if one notices the color at once after mixing the milk and the solution of brom-cresol purple and then again after the fat-globules have risen to form a cream layer at the upper surface. It will be seen that the color is lighter at the start than it is after the cream has risen and, further, that the cream layer shows little or no color. The difference is more marked with increase of milk-fat.

OPERATION OF METHOD.

1. *Preparation of Indicator.*

Brom-cresol purple is ground to a fine powder and dissolved in distilled water to saturation, about 0.1 gm. being used for 100 cc. of water. Saturation can be hastened by heating the mixture on a water bath, then cooling to room temperature, and filtering. The saturated solution contains about 0.09 per cent of the dye.

2. *Apparatus.*

The only apparatus required is the following: a burette, test-tubes, a pipette, and a test-tube holder.

The burette is used for the purpose of measuring the indicator. The delivery is so controlled that each drop measures 0.05 cc.

The test-tubes which we have found most convenient for use in making the test are flat-bottomed specimen tubes made of Pyrex glass, holding about 8 cc. They are about 4 inches long and $\frac{1}{2}$ inch in diameter. It is essential that all the tubes used should be uniform in color and in thickness of walls.

We have found it convenient to provide a special holder for these tubes, making it easy to compare the color by arranging the tubes in a line side by side in close contact without concealing any portion of the milk column.

Ordinary 3 cc. pipettes are used for measuring the milk to be used.

3. Performing the Operation.

The different steps in carrying out the details of the method consist of (a) measuring the indicator, (b) measuring the milk, (c) observation of the color, and (d) interpretation of the results.

(a) *Measuring the Indicator.*—The test-tubes are placed in the holder with the open end up. The burette is filled with the solution of brom-cresol purple, and the stop-cock so adjusted that it delivers drops measuring 0.05 cc. at the rate of about one drop in 2 seconds. The test-tubes are placed under the burette tip, one by one in turn, exactly one drop being allowed for each tube. The delivery is so controlled that each drop falls free from the burette tip into the test-tube without touching the walls of the tube before the drop separates from the burette tip. This procedure enables one to deliver the same amount of indicator into each test-tube with rapidity. There are two advantages in using only one drop of indicator. The first is the minimum dilution of the added milk and the second is that the tubes can be carried about without danger of losing the indicator.

(b) *Measuring the Milk Sample.*—The milk is added to each test-tube with a 3 cc. pipette and is thoroughly mixed with the indicator, which may be conveniently done either by shaking the tube or by drawing the mixture of milk and indicator into the pipette and allowing it to flow back into the test-tube. In our experience the proportion of 3 cc. of milk and one drop of brom-cresol purple solution enables one to observe the shades of color to best advantage in most cases, but in some cases we have obtained somewhat better results in observing color changes with 5 cc. of milk for one drop of indicator.

(c) *Observation of Color Change.*—The ability to distinguish shades of color in the change of reaction in milk is the chief point of difficulty and, therefore, the observation of shades of color

constitutes the main source of weakness in its application. The method cannot be used successfully by one whose eye is lacking in appreciation of different shades of color to such an extent that training does not enable one to overcome such deficiency. However, in our experience, any person with normal sensitiveness to color changes can acquire the ability to observe such changes as take place in milk treated with brom-cresol purple solution with an accuracy which will make the application of the method useful. The fundamental difficulty lies in the lack of a fixed color standard which is applicable under all conditions as a basis of comparison. In the examination of market milks, it usually suffices to assume that a large proportion of the samples is normal in reaction and that, therefore, in a collection of numerous samples, those which give the same color with the solution of brom-cresol purple are generally normal, while those samples which are lighter or darker are open to the suspicion of being abnormal in some respect and should be further examined by supplementary methods. It will be well usually, however, especially for those who are unaccustomed to the use of the method, to prepare a series of known standardized colors to be used as a basis of comparison in observing the reaction of unknown milks to which the test is applied.

Preparation of the Color Standard.—The prepared color standard represents approximately certain ranges of hydrogen ion concentration. Briefly stated, the preparation of such a standard consists in adding increasing amounts of standard alkali to a mixture of normal milk and brom-cresol purple solution. The preparation of the series of standard colors to be used for comparison is carried out in the following manner.

(1st) Selection of Milk.—The milk to be used in the preparation of the color standard should meet two requirements. First, it should have approximately the same general composition as that of the milks to be examined; and, second, it should have a normal reaction. In respect to composition, usually any normal market milk containing between 3 and 4 per cent of fat will be satisfactory in the inspection of market milks. When milks containing over 4.5 per cent of fat are to be tested, it is well to use for the color standard a milk containing about the same percentage of fat. In the case of partially skimmed milks, milk with less

than the normal percentage of fat should be used. The differences in color caused by the presence of varying percentages of fat can be largely overcome, when necessary, by removing the cream with a centrifuge from all the milks to be examined, using skim-milk in the preparation of the color standard. However, it should be stated that the color given by skim-milk obtained from milk rich in fat may be slightly different from that given by skim-milk obtained from milk poor in fat. After one has had some experience in studying the effect of different milks upon the solution of brom-cresol purple, it will be found that the matter of the selection of the milk for making a color standard is simpler than it might appear from the foregoing statements.

In respect to the reaction, the milk to be used in preparing the color standard should not have an acidity in excess of an equivalent of 18 cc. of 0.1 N NaOH per 100 cc. of milk. The determination is made by titrating 10 cc. of milk without dilution with the alkali, using 0.5 cc. of a neutralized, alcoholic solution of phenolphthalein for indicator. The reaction of the milk to be used for the color standard can be further tested by adding brom-cresol purple solution and comparing the resulting color with that given by this indicator with samples of milk of known normal character. If the reaction is uniform with that of the known normal milks, the milk can be satisfactorily used for the color standard. Usually a milk having an acidity equivalent to 1.8 cc. of 0.1 N NaOH per 10 cc. of milk is found to be satisfactory.

(2nd) *Preparation of Standard Color Series.*—Measure eight portions of milk of 10 cc. each into separate test-tubes and to each portion add the amount of 0.1 N NaOH indicated below.

Test-tube No.	1	2	3	4	5	6	7	8
No. of drops of 0.1 N NaOH.....	0	2	4	6	8	10	12	14

The alkali is added to the tubes from a burette, using the same precautions in regard to uniform size of drops and their delivery as have been already given for measuring the brom-cresol purple solution. The alkali and milk are thoroughly mixed. Of the mixture in each tube take 3 cc. and one drop of brom-cresol purple solution, making a series of eight mixtures contained in the kind of test-tubes previously described. These give a range

of colors to be used as a standard for comparison in testing unknown milks. The reaction color in each tube corresponds approximately to the following pH values.

No. in series.....	1	2	3	4	5	6	7	8
cc. of 0.1 N NaOH used.	0	0.1	0.2	0.3	0.4	0.5	0.6	0.7
pH value.	6.5	6.6	6.67	6.75	6.82	6.90	6.98	7.05
	to	to	to	to	to	to	to	to
	6.6	6.67	6.75	6.82	6.90	6.98	7.05	7.13
Symbol for reaction color	N	N-1	N-2	N-3	N-4	N-5	N-6	N-7

As a matter of convenience in tabulating results, we append a series of symbols to indicate the pH values, N standing for normal reaction and N followed by the minus sign and figures ranging from 1 to 7, indicating decreased acidity corresponding to increasing pH values.

It should be emphasized here that this method gives the reaction only approximately and the accuracy of the results may be interfered with by various conditions apart from the true reaction. Of such interfering factors, one which is especially influential in affecting the color is the degree of opaqueness. Milks of relatively low acidity tend to be less opaque than those of normal acidity. As a result the surface color observed is reflected from a greater depth and with a corresponding increase in the intensity of the color in the presence of brom-cresol purple solution, thus indicating a reaction less acid than that indicated by the standard. When necessary, this source of interference can be obviated by so diluting the standard series with water after the addition of alkali and before the addition of the brom-cresol purple solution that the milk to be used as a standard will resemble in its appearance of opaqueness that of the unknown milk. The milk thus diluted is then used in making up a special standard series by addition of indicator. While the addition of water changes the reaction of the standard somewhat, the test of the reaction by the color is made more accurate than if the standard is undiluted.

Another factor which may render less accurate the use of the standard in determining the reaction of unknown milks is the initial reaction of the milk used for the standard. If, for example, the initial reaction is pH 6.5 in one case and pH 6.6 in another,

there would be a difference of 0.1 pH in applying the standard to the reaction of unknown milks.

(d) *Interpretation of Color.*—In examining the samples of milk in the test-tubes after addition of the milk to the brom-cresol purple solution, one makes comparison with the prepared color standard; or, in the absence of such a standard, one selects those samples which differ in color markedly from those samples which, according to experienced observation, appear normal, either before or after the separation of the cream. Such samples as appear to be abnormal by showing a deeper blue shade of color, indicating decreased acidity, are open to the suspicion of being watered, or skimmed, or treated with alkaline salts, or containing excessive numbers of leucocytes as in milk from diseased udders. Which of these suspicions is justified can be ascertained by the determination (1) of the freezing-point, (2) of the percentage of milk-fat or the ratio of fat to proteins, (3) of the specific gravity, (4) of the total solids, (5) of the presence of alkaline salts, especially sodium bicarbonate and borax, (6) of the numbers of leucocytes by direct microscopic examination by Breed's method,³ and (7) of CO₂⁴ by Van Slyke's method modified by us for use in connection with milk.

In the case of samples showing a color lighter than normal with the brom-cresol purple solution, indicating an abnormal degree of acidity, there is awakened the suspicion of bacterial acid production, the presence of formaldehyde, overheating, or the presence of added acid salts; or the lighter color may be due to a high percentage of milk-fat. Which of these indications is correct is determined as follows: A direct count of the number of bacteria³ is often sufficient. If this fails to show the presence of excessive numbers of bacteria, then a test should be made for the presence of formaldehyde, and, if this is not present, the percentage of milk-fat is determined; and, further, in order to see if the light color is due to overheating, the determination of carbon dioxide should be made and Storck's test may also be applied.

³ Breed, R. S., *New York Agric. Exp. Station, Techn. Bull.* 49, 1916.

⁴ Van Slyke, L. L., and Baker, J. C., *J. Biol. Chem.*, 1919, xl, 337.

RESULTS OF APPLICATION OF METHOD.

Relation between the Reaction of Milk and the Presence of Added Water and of Garget.

We have made application of this preliminary test extensively in the case of market milk and especially in connection with watered milk and milks containing garget and also milks with a high bacterial content.

Of 570 samples of market milk to which the test was applied, 64 samples, of which 52 showed decreased acidity, were selected by the brom-cresol purple test for more detailed examination in relation to the presence of added water and high leucocyte content. The results of the work are summarized in Table I. Each sample of market milk represented a single can of milk as delivered at the milk station by the producer. Milk from the same producer was sampled on several different days in those cases in which there was cause for suspecting the milk to be abnormal. Most of the samples giving a normal color reaction (N) were selected from the milk of producers whose milk appeared on previous inspection to show signs of being watered but which gave a normal reaction at the time of this sampling. There are given in addition results in the case of a few samples (Nos. 23 to 28) of milk obtained from different quarters of the udders of cows, some of which were known to have udder infection, and there are also three samples (No. 6) of normal mixed milk from our Station herd.

An examination of the results contained in Table I leads to the following summarized statements:

1. Of the selected 64 samples of market milk, 52 show a color reaction less acid than normal and 12, a normal reaction.

2. In all the samples giving a normal color reaction, the depression of the freezing-point varies between -0.54 and -0.57° . In the 52 samples of market milk showing a reaction less acid than normal, constituting nearly 10 per cent of all the samples examined by the color test, 39 samples show a depression of the freezing-point varying from -0.468 to -0.538° , thus indicating the presence of added water. In 18 samples giving N-1 color reaction (pH 6.6 to 6.67), 10 samples show watering by the

TABLE I.

Results of Examination of Market Milk by Brom-cresol Purple Test.

Herd No.	Reaction.	Depression of freezing-point.	Garget.	Herd No.	Reaction.	Depression of freezing-point.	Garget.
		<i>degree</i>				<i>degree</i>	
1	N	0.569	0	13	N-2	0.538	0
2	"	0.558	0	13-a	"	0.509	0
3	"	0.558	0	14	"	0.477	0
4	"	0.560	0	14-a	N	0.548	0
4-a	"	0.560	0	14-b	N-2	0.530	0
6	"	0.548	0	14-c	"	0.512	0
5	"	0.552	0	14-d	"	0.490	0
6-a	"	0.555	0	14-e	"	0.523	0
6-b	"	0.562	0	14-f	"	0.503	0
7	N-1	0.536	Present.	14-g	"	0.513	0
7-a	N	0.546	0	14-h	"	0.520	0
7-b	N-1	0.546	Present.	14-i	"	0.525	0
7-c	"	0.550	"	14-j	"	0.500	0
7-d	"	0.536	"	14-k	"	0.530	0
7-e	N	0.558	0	15	"	0.518	0
7-f	N-1	0.552	Present.	15-a	"	0.536	Present.
7-g	"	0.549	"	15-b	"	0.543	"
7-h	"	0.549	0	15-c	N-1	0.518	0
7-i	N	0.553	0	16	N-2	0.523	0
8	N-1	0.528	0	16-a	"	0.506	0
8-a	"	0.547	0	16-b	N-1	0.512	0
8-b	N-2	0.530	0	16-c	N	0.556	0
8-c	N-1	0.545	0	16-d	N-2	0.496	0
8-d	"	0.538	0	17	"	0.494	0
8-e	N-2	0.541	0	18	N-3	0.519	0
8-f	N-1	0.563	Present.	19	N-2	0.530	0
8-g	N-2	0.540	0	20	N-1	0.491	0
9	"	0.518	0	21	"	0.531	0
9-a	"	0.531	0	22	N-2	0.540	0
9-b	"	0.512	0	22-a	"	0.540	0
9-c	N-1	0.530	0				
10	N-2	0.500	0	23	N	0.558	0
10-a	N-1	0.512	0	24	"	0.558	0
10-b	N	0.558	0	25	N-4	0.510	Present.
10-c	N-3	0.470	0	26	"	0.563	"
11	"	0.468	0	27	N-5	0.558	"
12	"	0.519	0	28	"	0.548	"

freezing-point determination, while 8 do not. Of these 8 samples, the decreased acidity is due to the presence of garget in 5 cases. The other 3 cases are on the borderline as shown by the freezing-point depression. In 30 samples showing N-2 color reaction (pH 6.67 to 6.75), 25 contain added water according to the freezing-point, while 5 are just on the border line, showing a freezing-point depression varying from -0.54° (in 3 cases) to -0.543° . In the case of 4 samples (10-c, 11, 12, 18), giving a color reaction of N-3 (pH 6.75 to 6.82), all showed the pres-

TABLE II.
Results of Examination by Herds.

Herd No.	No. of times examined.	No. of samples with subnormal reaction.	No. of samples watered.	No. of samples with garget.
7	10	7	0	6
8	8	8	3*	1
9	4	4	4	0
10	4	3	3	0
11	1	1	1	0
12	1	1	1	0
13	2	2	2	0
14	12	11	11	0
15	4	4	3†	1
16	5	4	4	0
17	1	1	1	0
18	1	1	1	0
19	1	1	1	0
20	1	1	1	0
21	1	1	1	0
22	2	2	0	2

* 2 others doubtful.

† 1 other doubtful.

ence of added water by the freezing-point. In the case of 2 samples (25, 26), having a color reaction of N-4 (pH 6.82 to 6.90) and of 2 samples (27, 28) with a reaction of N-5 (pH 6.90 to 6.98), the decreased acidity was due in every case to garget, the determination of the freezing-point showing the milks to be entirely normal in water content. For further details regarding the reaction of milk to udder infection see page 351.

3. The number of dairies furnishing the 570 samples of milk examined was 46. In the case of 16 dairies, the milks showed a

subnormal or decreased acid reaction by the brom-cresol purple test. Three-fourths of these subnormal samples came from a few herds. It was found that in one of these the milk was being watered regularly and some of the milk from the other herds gave evidence of severe mastitis. Table II shows the number of milks of subnormal reaction in the case of the 16 herds and indicates also the total number of examinations and the number of times the samples were found watered and, in addition, the cases where garget was present.

It is seen that in the case of the 16 herds, 58 examinations of milk were made; in 52 samples, the reaction was found to be subnormal or of decreased acidity. In these 52 cases, 37 showed clear evidence of watering by the depression of the freezing-point and 3 others were so close to the border line as to be open to a strong suspicion of being watered. There were three herds in which persistent addition of water was shown.

4. The 6 samples, 23-28, were drawn from the udders under our direct supervision. Four of these showed a subnormal reaction, owing to the presence of garget, and the freezing-point test shows that the percentage of water is not excessive. A complete chemical analysis of these four samples would undoubtedly show an abnormal composition according to our work (page 350).

Relation Between the Reaction of Milk and the Bacterial Content.

Milks showing a reaction above normal acidity, as indicated by giving with brom-cresol purple solution a lighter color, were examined for their bacterial content. Of the 570 samples examined, 16 gave a lighter color than normal, of which 11 were found by Miss Mildred C. Davis, the City Bacteriologist; to contain over 10,000,000 bacteria per cc. by the direct-count method.³ In the case of two of the other samples, the light color was due to high milk-fat content, bacteria not being present in large numbers.

A further study was made at the Laboratories of the Department of Health of New York City through the courtesy of the Director, Dr. Wm. H. Park. Of the 11 samples found showing a light color with brom-cresol purple solution, four contained

over 1,000,000 bacteria per cc. by the plate-count method and six showed high percentage of milk-fat with low bacterial content.

SUGGESTIONS.

It has been stated already that the main source of weakness in the application of this method is the observation of the shade of color given by the sample of milk with brom-eresol purple solution. It is, therefore, important that, before one attempts to use the method in practical application, some special work be done in a study of the shades of color of the brom-eresol purple solution in milk under a great variety of conditions. For example, taking some fresh normal milk of average composition, that is, with 3 to 4 per cent of milk-fat, a portion is treated with brom-eresol purple solution in the manner described (page 361), and then other portions are treated by the addition of definite amounts of 0.1 N alkali, just as in the preparation of the standard color series (page 363), and other portions by 0.1 N lactic acid, while other portions are diluted with definite amounts of water, and others are skimmed, and others have cream added to them. Also the results of the action of definite amounts of formaldehyde added to portions of the milk should be studied; and also the effects of the addition of varying amounts of sodium bicarbonate, borax, etc. Portions of milk heated to various temperatures are similarly studied. A similar complete study should be made with different samples of normal milk until one is able to distinguish different shades of color so far as they have a meaning in practical applications of the test.

It should be emphasized here again that the application of the brom-eresol purple test is not to be regarded as final but only as preliminary and suggestive. Its chief value is to be found in the fact that, when properly used, it will greatly minimize the work involved in official milk inspection, because it will point in most cases directly to the milks that are abnormal and, therefore, indicate which samples need further detailed work to confirm or disprove the suspicion aroused by the result of the preliminary test.

SUMMARY.

The method described as a means for the preliminary detection of abnormal milks is based upon the use of the dye, dibrom-ortho-cresol-sulfon-phthalein, the name being abbreviated to brom-cresol purple. One drop of a saturated water solution is mixed with 3 cc. of milk and the color is observed. Normal fresh milk gives a grayish-blue color. The production of a darker or lighter color serves to awaken suspicion in regard to the normal character of the milk. The color is made lighter by acids, formaldehyde, and also by heating above the usual point of pasteurization. The color becomes deeper blue in the case of milk from diseased udders, watered milk, skimmed milk, and milk containing added alkaline salts. In the inspection of milk, a sample is taken for further detailed examination in the laboratory if the color is sufficiently lighter or darker than normal to indicate the probability of some abnormal condition.

The method has been applied and results are reported for 570 samples of market milk. Watered milk was detected and also milk containing excessive numbers of leucocytes. A standard of colors can be prepared by which comparison can be made and conclusions more easily reached as to the normality or abnormality of the samples examined.



A METHOD FOR THE DETERMINATION OF THE KEEPING QUALITY OF MILK.

BY JOHN C. BAKER AND LUCIUS L. VAN SLYKE.

(From the Chemical Laboratory of the New York Agricultural Experiment
Station, Geneva.)

(Received for publication, October 8, 1919.)

INTRODUCTION.

Keeping quality or keeping power is an expression used to indicate the length of time milk remains sweet and otherwise palatable and suitable for direct consumption. This is obviously an important factor in estimating the commercial value of market milk, since milk that is sour or otherwise unpalatable is comparatively valueless for direct use, however rich it may be in fat and other solids.

Various methods have been proposed for measuring the keeping quality of milk but these have been found unsatisfactory in actual practice. Therefore, a method which can be utilized to furnish consistent results in measuring, even though only approximately, the keeping quality of different milks is needed.

Proposed Method.

We have found that the brom-cresol purple test (see page 359) can, with simple modifications in technique, be applied to the measurement of certain factors affecting the keeping power of milk. In applying the test for this purpose, the test-tubes and pipettes must be sterilized before use and the milk in the test-tubes must be incubated for a stated length of time at a definite temperature. Examination of the milk after incubation furnishes evidence in respect to the keeping power of milk as shown by one or more of several possible changes that may take place in the milk. Such changes can be divided into two classes, first, those affecting the color of brom-cresol purple, which show a

change of reaction in the milk due to the production of acid or less often to the formation of alkali salts; and, second, other accompanying or succeeding changes, such as curdling of the milk due to coagulation of casein, digestion of casein, changes in the character of the coagulated or curdled milk, production of gas, and the development of abnormal odor and taste.

Non-Germicidal Effect of Brom-Cresol Purple Solution.

In order to be of value as a means of measuring the keeping quality of milk by the reaction, it is essential that the brom-cresol purple solution should not, under the conditions used, show any germicidal effect sufficient to interfere with the growth of bacteria in milk. In order to test this fundamental requirement, pure cultures of *Bacterium lactis acidi* were added to freshly pasteurized skim-milk; one portion of this was treated with brom-cresol purple solution and both portions were incubated at 20°C. At intervals the brom-cresol purple test was applied to samples taken from the incubated portion of milk containing none of the indicator, and comparison was made with the portion to which brom-cresol purple had been added at the start. Also samples of the two portions of milk were titrated with alkali. These tests were made many times with different milks, but in no case was there observable any difference in behavior. The same tests were also applied in numerous cases to two portions of a milk undergoing the process of natural souring, using both unheated and pasteurized milk, without showing any difference. The results all go to show that the brom-cresol purple solution has no germicidal effect under the conditions used. However, it is advisable to take precaution to use for this test only brom-cresol purple that is wholly free from the odor of phenol or cresol, as suggested by Clark and Lubs.¹ In our experience it is not difficult to obtain this.

Production of Acid.

In considering the application of the brom-cresol purple test to the measurement of the keeping quality of milk as shown by the formation of acid in milk, we will present the subject under

¹ Clark, W. M., and Lubs, H. A., *J. Agric. Research*, 1917, x, 105.

the two heads, localization of acid production and degrees of acid production.

Localization of Acid Production.—In the natural souring of milk standing undisturbed, the formation of acid rarely proceeds uniformly through the body of the milk but is largely localized, especially in the earlier stages of the process. Acid is usually first formed in appreciable amount at the upper surface next the cream layer, or less often in the layer at the bottom of the container, or it may appear in some cases simultaneously in both the top and bottom layers. Less frequently it may start in the layer of milk next the side walls of the container.

When acid is formed first at the upper surface of the milk, it is probably due to the fact that the organisms are enmeshed and carried upward with the rising fat-globules and are thus concentrated in the upper layer. The bacteria left in the body of the milk after the rising of the fat-globules would tend, under the downward pulling effect of gravity, to settle at the bottom of the container. Generally, the number carried up is apparently greater than that carried down. Such a concentration of bacteria in the top or bottom layer of the milk would have the effect of making the brom-cresol purple test more sensitive as a result of more rapid formation of acid. The effect of acid development is more commonly shown first in the upper layer, though sometimes in the lower or less often in the side layer. But whether it starts at the top or bottom or side, the process of acid production works from the starting area or areas through the main body of the milk.

Degrees of Acidity.—It would be desirable, if it were possible, to distinguish different degrees of increasing acidity by preparing a color standard representing different values of hydrogen ion concentration, similar to the method described on page 363 for determining the approximate hydrogen ion concentration of milk when its acidity is less than that of normal milk. This is impossible for several reasons and especially because, as pointed out above, the production of acid is localized and not distributed uniformly through the body of the milk. However, we have found that it is possible, with some experience, to distinguish readily not less than four degrees or stages of acidity by changes of color, varying from the grayish-blue observed with normal

fresh milk to a pure yellow occurring in milk sufficiently sour to undergo coagulation, which occurs at about pH 4.65. These four stages or degrees of acidity can be distinguished by the following description.

(1) The first stage or beginning of acid production (A_1) is indicated by the first sign of change from the grayish-blue color of normal milk to a lighter shade observable in any portion of the milk. This is most often distinguishable at the upper surface of the milk just under the cream layer, though it may occur at the bottom layer of the milk or less frequently at the side walls of the containing vessel.

(2) The second stage (A_2) shows distinct acid production and is indicated when the milk in a test-tube gives evidence of more extensive and marked change of color than in case of A_1 . The main body of the milk, however, still retains a grayish-blue color more or less interspersed with, but predominant over, yellowish or greenish-yellow shades. The prevailing color may be bluish or a dull shade of bluish-green.

(3) The third stage (A_3) shows marked acid production and is indicated when the color of the milk in the test-tube appears greenish to greenish-yellow; the yellow is predominant through the body of the milk, though not complete, but is more or less interspersed with shades intermediate between dull green and yellow.

(4) The fourth stage (A_4) of acid production is easily observable, since the color is a pure, fairly uniform yellow, free from every trace of bluish or greenish tints. The curdling of the milk usually occurs at this stage and is generally, though not always, readily seen.

It can easily be understood that these divisions are somewhat arbitrary and not always capable of sharp separation but they afford a practical basis for differentiating milks, furnishing a test which greatly exceeds in delicacy and ease of application the usual titration methods. With experience in distinguishing shades of color, it is easily possible to carry the division of classes further if desired; but usually the four broad classes described above suffice for most purposes.

Other Changes in Milk.

Changes other than those produced by acid formation can also be observed, and to these attention will be briefly called. Such changes may occur only after somewhat prolonged incubation in the case of good market milks, but they appear more quickly in the case of milks which have been drawn more than 24 hours before incubation, or in the case of milks drawn under unfavorable conditions as to cleanliness and not kept at a sufficiently low temperature. It should be stated here that while these changes have been studied by bacteriologists, it is essential that they be given special attention and further study under the conditions of the proposed test.

1. *Production of alkali* during incubation is shown by decreased acidity and is indicated by increase of depth of the grayish-blue color given with normal milk by the brom-cresol purple solution.

2. *Digestion of casein* is observable just below the cream layer and is indicated by the appearance of a layer of more or less clear solution.

3. *Gas production* is easily observed, indicating the presence of gas-producing organisms. This test is especially valuable in connection with milk to be used for cheese-making.

4. *The contraction or shrinking of the curd* or coagulated casein into a smaller mass is easily seen when it occurs. This is accompanied by the separation of more or less clear whey.

5. *Any abnormal odor or taste* is readily ascertained by any one having well developed senses of smell and taste. Such abnormal conditions have been noticed in our experience only in the case of milks which had shown marked change in reaction as indicated by the color given with brom-cresol purple solution.

RESULTS OF APPLICATION OF THE METHOD.

In applying the brom-cresol purple test to the measurement of acid production in relation to the keeping quality of milk, two separate series of experiments will be presented. In the first series, the samples used were taken from individual cans of milk as delivered by producers at the two collecting stations handling the supply of the city of Geneva. In the second series,

the samples were obtained from the regular milk supply of New York City.

1. *The Geneva Samples.*—In applying our method to 389 samples obtained in Geneva, we have had the cooperation of the city bacteriologist, Miss Mildred C. Davis, who classified the samples into groups by microscopical examination, using the direct-counting method.²

The results are summarized in Table I.

In interpreting the results of the microscopical examination with reference to the fitness or keeping quality of milk for domestic use, milks in Class I are regarded as excellent, in Class II as satisfactory, in Class III as unsatisfactory, and in Class IV as

TABLE I.

Comparison of Results of Brom-Cresol Purple Test with Classification by Microscopical Examination.

Class.	No. of individual bacteria per cc. of milk.	No. of samples examined.	No. of samples changing color.	No. of samples not changing color.	Milk showing good keeping quality.	Milk showing poor keeping quality.
					per cent.	per cent.
I	Below 350,000.....	283	41	242	85.5	14.5
II	Between 350,000 and 1,000,000.....	21	6	15	71.5	28.5
III	“ 1,000,000 and 10,000,000..	52	33	19	36.5	63.5
IV	Over 10,000,000.....	33	27	6	18.0	82.0

very unsatisfactory. While there is a general correspondence between the results obtained by the microscopical examination and by the brom-cresol purple test, the agreement is not complete. In Class I, representing milk of excellent quality by microscopical examination, 242 samples out of 283 show no change by the brom-cresol purple solution, thus confirming the results of the microscopical examination; but 41 samples out of the 283, or 14.5 per cent, show sufficient increase of acidity to be detected by the brom-cresol purple solution. In Class II, of the 21 samples graded as satisfactory by microscopic examination, 6 samples, or 28.5 per cent, show increase of acidity with brom-cresol purple solution. In Class III, 52 samples are graded as unsatisfactory

² Breed, R. S., *New York Agric. Exp. Station, Techn. Bull. 49, 1916.*

by the microscopic method, while 19 samples, or 36.5 per cent, fail to show increased acidity. In Class IV, 33 samples are graded as very unsatisfactory by the microscopical method, but of these there are 6, or 18.0 per cent, which show no increase of acidity. These observed differences of interpretation in the application of these two methods to the determination of keeping quality in milk are what might be expected under the conditions and are easily explained. The brom-cresol purple test is here applied to detect increase of acidity while the microscopical examination includes all kinds of bacteria and not merely those capable of producing acid. It is obvious that in the case of bacteria producing no acid or only very small amounts under the conditions of the test, the brom-cresol purple test would not be expected to apply as it does in the case of marked acid producers.

2. *The New York City Samples.*—These samples were obtained in the regular inspection work of the city milk supply, through the courtesy of Dr. Wm. H. Park, Director of the Laboratories of the Department of Health. We are indebted also to Dr. Hazel Hatfield for the work done in making the bacteriological examinations of the samples. There were examined 220 samples of unheated or raw milk and 186 of pasteurized milk. The bacteriological examination was made by the official plate method after incubation at 37°C. The tests with brom-cresol purple solution were made in all cases on samples incubated at 18°C. for 24 hours. This temperature is higher than that found in efficient household refrigerators, but it may be regarded as representing approximately the average temperature at which milk is kept after delivery to the consumer.

The division into classes on the basis of bacterial content has been carried farther than in case of the Geneva milks, providing fifteen different divisions as shown in Table II.

The results with the raw milks examined in New York City show, in general, that when the numbers of bacteria increase, there is an increase in the percentage of samples showing increase of acidity. Milks with high bacterial content usually show poor keeping quality by the brom-cresol purple test, while those containing small numbers of bacteria generally show good keeping quality by the color test. However, some milks with fairly high

Keeping Quality of Milk

TABLE II.

Results of Examination of New York City Milks.

Class	Raw Pasteur- ized.	No. of colonies developed per cc. of milk.	No. of samples.	No. of samples showing change of reaction.	No. of samples not show- ing change of reaction.	Milk classed as poor by		Milk classed as good by	
						per cent	per cent	per cent	per cent
I	R	Below 1,000.....	0	0	0	0	0	—	—
II	"	Between 1,000 and 5,000....	4	0	4	0	0	100	100
III	"	" 5,000 " 10,000....	6	0	6	0	0	100	100
IV	"	" 10,000 " 20,000....	4	3	1	75	25		
V	"	" 20,000 " 30,000....	10	5	5	50	50		
VI	"	" 30,000 " 60,000....	17	14	3	82.4	17.6		
VII	"	" 60,000 " 100,000....	23	22	1	95.7	4.3		
VIII	"	" 100,000 " 150,000....	25	20	5	80	20		
IX	"	" 150,000 " 250,000....	57	54	3	94.7	5.3		
X	"	" 250,000 " 400,000....	16	14	2	87.5	12.5		
XI	"	" 400,000 " 600,000....	16	16	0	100	0		
XII	"	" 600,000 " 1,000,000....	20	20	0	100	0		
XIII	"	" 1,000,000 " 1,500,000....	10	9	1	90	10		
XIV	"	" 1,500,000 " 3,000,000....	7	7	0	100	0		
XV	"	Over 3,000,000.....	5	5	0	100	0		
I	P	Below 1,000.....	4	0	4	0	100		
II	"	Between 1,000 and 5,000....	16	1	15	6.2	93.8		
III	"	" 5,000 " 10,000....	9	1	8	11	89		
IV	"	" 10,000 " 20,000....	32	0	32	0	100		
V	"	" 20,000 " 30,000....	32	2	30	6.2	93.8		
VI	"	" 30,000 " 60,000....	28	3	25	10.7	89.3		
VII	"	" 60,000 " 100,000....	20	5	15	25	75		
VIII	"	" 100,000 " 150,000....	15	9	6	60	40		
IX	"	" 150,000 " 250,000....	13	12	1	92.3	7.7		
X	"	" 250,000 " 400,000....	4	2	2	50	50		
XI	"	" 400,000 " 600,000....	5	5	0	100	0		
XII	"	" 600,000 " 1,000,000....	3	3	0	100	0		
XIII	"	" 1,000,000 " 1,500,000....	5	5	0	100	0		
XIV	"	" 1,500,000 " 3,000,000....	0						
XV	"	Over 3,000,000.....	0						

bacterial content show good keeping quality, while some with a low content show poor keeping quality, by the brom-cresol purple test.

With pasteurized milks we obtain similar results, except that a large proportion of the milks with the higher bacterial content show good keeping quality by the brom-cresol purple test.

The results obtained with the New York City milks are not properly comparable with those obtained with the Geneva milks, especially for two reasons. In the first place, the two methods of obtaining the bacterial content, Breed's direct-counting method and the so-called official plate method, do not give results sufficiently comparable for our purpose. In the second place, the New York City milks average probably not less than 24 hours old when the samples are used for laboratory work, while the Geneva samples are not more than 6 to 16 hours old.

In the summary of the results here presented, we do not give the varying degrees of acidity developed on incubation but only the general fact of an increase. Data in greater detail are being collected.

Additional Work.

While some observations have been made on the relation of the other factors to keeping quality, much additional work remains to be done along the following lines: (1) Digestion of casein, (2) production of alkali, (3) production of gas, (4) taste and odor, (5) relation of age of milk to temperature and length of time of incubation.

SUMMARY.

1. Brom-cresol purple can be used to measure approximately and relatively the keeping quality of milk. The test is applied in the manner described in the article preceding (page 357), with the modification that the pipettes and test-tubes used are sterilized before sampling the milk, and, further, the samples of milk in the test-tubes must be incubated a given time at a given temperature (usually 18° to 20° C.). The milk is examined for changes of color at 24 hour intervals. The main factor shown by this test as related to keeping quality is production of acid, but

additional factors to be observed are coagulation of casein, digestion of casein, production of alkali, production of gas, development of abnormal odor and taste.

2. In showing the development of acidity, four stages of progress are distinguishable through change of color, varying from the grayish-blue of brom-cresol purple in normal milk to a final clear yellow, the intermediate stages showing mixtures of color. In comparing this test with the bacterial count, it is found that in general large numbers of bacteria and increase of acidity are in fair correlation.

3. The other factors related to keeping quality, such as digestion, gas, alkali production, and abnormal odor and taste, are readily observable, but frequently not until after 24 hours of incubation.

EXTRACTION AND CONCENTRATION OF THE WATER-SOLUBLE VITAMINE FROM BREWERS' YEAST.*

BY THOMAS B. OSBORNE AND ALFRED J. WAKEMAN.

(From the Laboratory of the Connecticut Agricultural Experiment Station,
New Haven.)

(Received for publication, October 1, 1919.)

In making experiments to determine the nutritive value of individual proteins it is necessary to employ a source of the water-soluble vitamine in the synthetic diet. Heretofore it has been customary to feed some natural product such as protein-free milk, wheat embryo, or yeast to supply the necessary amount of this vitamine. All such products, however, contain relatively considerable quantities of nitrogenous substances, including proteins, hence there is always a question as to whether, or not, these so supplement deficiencies in the protein being tested as to give more or less misleading results. Such criticisms are not entirely unjustified because the nitrogen supplied together with the vitamine may be equal to 10 to 12 per cent of the nitrogen fed. Since some of such nitrogen belongs to protein and most of this to amino-acids identical with those contained in the protein being tested there is little reason to believe that the results of the experimental feeding are seriously affected. Nevertheless there is always a possibility that this may happen and we have had a feeling that some of our results may have been affected to a noticeable extent. A concentrated preparation of the water-soluble vitamine would also be of value for feeding experiments with inorganic salts as well as with individual carbohydrates. With a view to producing such a preparation we have attempted to concentrate the water-soluble vitamine in a fraction of yeast.

We have long known that the water-soluble vitamine is insoluble in absolute alcohol, hence it seemed probable that by

* The expenses of this investigation were shared by the Connecticut Agricultural Experiment Station and the Carnegie Institution of Washington, D. C.

fractionally precipitating the aqueous extract with alcohol this might be concentrated in a fraction and thus be obtained together with a comparatively small proportion of the other constituents of the yeast.

The first step towards this end was the preparation of an aqueous extract which should contain as much of the vitamine and as little of the other constituents of the yeast as possible. Almost all investigators who have attempted to separate the water-soluble vitamine from yeast have apparently considered it necessary to bring into solution as much as possible of the contents of the yeast cells. To accomplish this they have generally allowed the yeast to undergo autolysis, whereby a considerable part of the protein, as well as of other constituents of the yeast, is converted into water-soluble products largely of unknown character.

If the protein in the living yeast could be coagulated by boiling water before undergoing any autolytic change, and the water-soluble vitamine be simultaneously extracted, the conditions for a concentration of this vitamine in a fraction of the water extract would be greatly simplified.

EXPERIMENTAL.

Several liters of fresh bottom yeast were obtained directly from a brewery, and immediately diluted with ice water. After centrifuging, the sediment was washed twice more in the same way. The moist, washed yeast weighed 264 gm., equal to 48 gm. dried at 107°. This was stirred gradually into 1 liter of boiling distilled water containing 10 cc. of 1 per cent acetic acid. After boiling for about 2 minutes the solids were separated from the extract with the centrifuge. The residue was washed once by boiling with 0.01 per cent acetic acid and, after centrifuging, the extracts were united and concentrated to 500 cc. This concentrated extract contained 8.14 gm. of solids, equal to 17.1 per cent of the dry yeast, and 0.666 gm. of nitrogen, equal to 14.4 per cent of the original yeast nitrogen, or to 8.18 per cent of the solids of the extract.

Although this extract contained less than one-fifth of the yeast solids it contained nearly all the water-soluble vitamine.

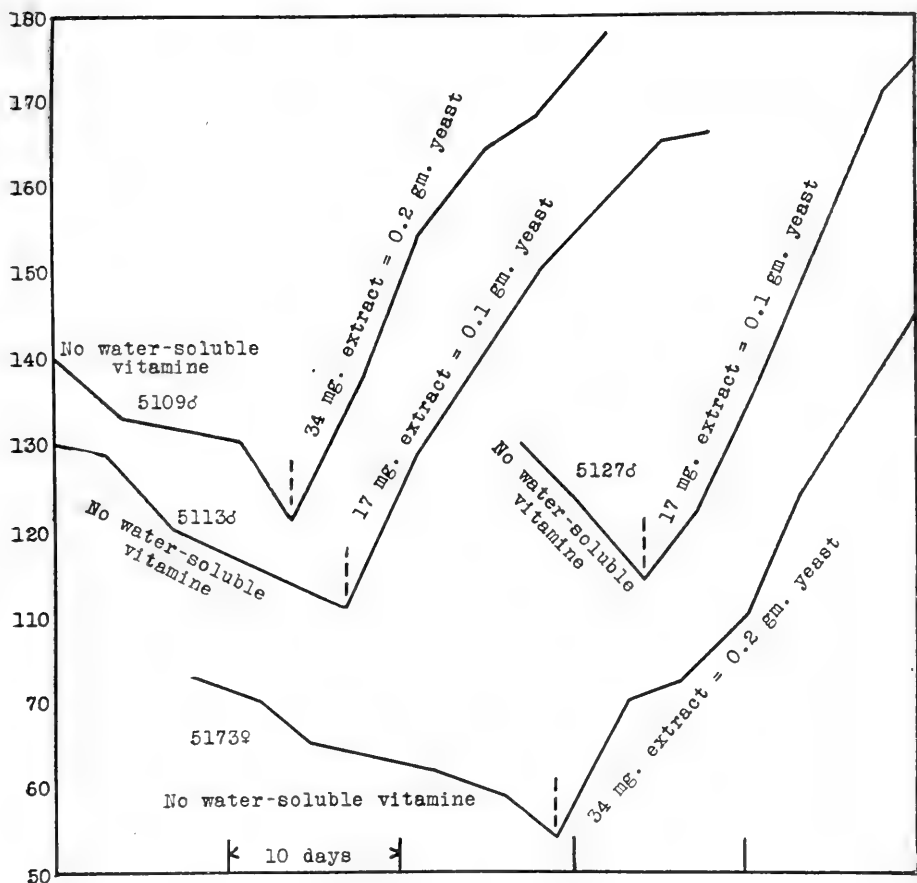

CHART I. Young rats declining on a diet free from water-soluble vitamine recover when the solids extracted from live yeast by boiling water are added in a quantity equal to 0.1 to 0.2 gm. of the original yeast.

Chart I (see Rats 5113 and 5127) shows that daily doses of 17 mg. of the solids of this extract promoted the recovery and rapid growth of young rats declining on a diet free from the water-soluble vitamine, but which in other respects was adequate. When 34 mg. of the yeast extract were fed (see Rats 5109 and 5173) the rate of gain was no greater, hence it appears that the smaller dose supplied as much of the water-soluble vitamine as

these animals needed. These doses were equivalent to only 0.1 and to 0.2 gm. respectively of the original dried yeast. Usually 0.1 gm. of dried yeast is not sufficient to promote such a vigorous gain of weight as these rats showed, hence we conclude that this boiling water extract contained nearly all the water-soluble vitamine of the yeast from which it was derived.

When we found that this aqueous extract was so rich in the water-soluble vitamine, a similar extract from a larger quantity of fresh bottom yeast was subjected to fractional precipitation by alcohol. After washing with ice water, the 4.5 kilos of the moist yeast, equal to 830 gm. dried at 107°, were stirred slowly into 10 liters of boiling water containing 0.01 per cent of acetic acid. After boiling about 5 minutes the extract was readily filtered through folded soft papers. The residue was washed once by boiling with 5 liters of 0.01 per cent acetic acid and the washings, united with the main extract, were concentrated to 2 liters. This contained 140 gm. of solids, equal to 16.9 per cent of the dry yeast, and 12.02 gm. of nitrogen, equal to 13.7 per cent of the original yeast nitrogen, or to 8.6 per cent of the solids of the extract. These are substantially the same proportions as were found in the preceding experiments.

The concentrated extract was then poured into 3 liters of 93 per cent alcohol, making the alcoholic content of the mixture about 52 per cent by weight. The flocculent precipitate, Fraction I, which separated, when washed with 52 per cent alcohol, digested with absolute alcohol, and dried over sulfuric acid, formed a nearly white powder, equal to 35.9 gm. dried at 107°. This fraction formed 4.3 per cent of the dry yeast or 25.6 per cent of the solids of the water extract. It contained 1.72 gm. of nitrogen, equal to 1.9 per cent of the original yeast nitrogen, or to 4.8 per cent of the precipitate. Its ash content was 47.15 per cent.

The filtrate and washings from Fraction I were concentrated to 300 cc. and poured into 1,960 cc. of 93 per cent alcohol, making the alcoholic content of the mixture about 79 per cent by weight. The precipitate, Fraction II, thereby produced was washed once with 79 per cent alcohol, and then twice dissolved in about 100 cc. of water, and reprecipitated by pouring into enough alcohol to make the alcoholic concentration 90 per cent by weight. After

digesting under absolute alcohol and drying over sulfuric acid a light-colored, friable product was obtained equal to 51.8 gm. dried at 107°, or to 37 per cent of the solids of the extract, or to 6.2 per cent of the dried yeast. This contained 7.5 per cent of nitrogen, equal to 4.5 per cent of the nitrogen of the original yeast, and 10.65 per cent of ash.

The united solutions from Fraction II were concentrated to a small volume and poured into enough absolute alcohol to make the alcoholic concentration of the mixture 90 per cent by weight. The precipitate which separated, Fraction III, was dissolved in 100 cc. of water and again precipitated by alcohol at 90 per cent. Since this precipitate was gummy it was again dissolved in about 30 cc. of water and the solution poured into 500 cc. of absolute alcohol. The still gummy precipitate was digested with absolute

TABLE I.

	Solids.	Nitrogen.	Solids.		Nitrogen.		Ash of fraction.
			Of yeast.	Of water extract.	Of fraction.	Of yeast.	
			<i>per cent</i>	<i>per cent</i>	<i>per cent</i>	<i>per cent</i>	
	<i>gm.</i>	<i>gm.</i>					<i>per cent</i>
Water extract.....	140.0	12.0	16.9	100.0	8.6	13.72	21.70
Fraction I.....	35.9	1.7	4.3	25.6	4.8	1.94	47.15
“ II.....	51.8	3.9	6.2	37.0	7.5	4.45	10.65
“ III.....	13.9	1.8	1.6	9.9	13.1	2.06	15.90
“ IV.....	36.1	3.9	4.4	25.8	10.8	4.45	15.90

alcohol and dried over sulfuric acid. Fraction III weighed 13.85 gm. dried at 107°, equal to 1.6 per cent of the original dried yeast, or to 9.9 per cent of the solids of the water extract, and contained 1.81 gm. of nitrogen equal to 13.1 per cent of the fraction, or to 2.06 per cent of the yeast nitrogen. Its ash content was 15.9 per cent.

The strong alcoholic solutions from Fraction III were united and concentrated to small volume. Owing to the gummy character of the dissolved solids these were preserved in strong alcohol. This solution contained solids, Fraction IV, equal to 36.1 gm. dried at 107°, equivalent to 4.4 per cent of the original yeast or to 25.8 per cent of the solids of the water extract. It contained 10.83 per cent of nitrogen, equivalent to 4.5 per cent of the yeast nitrogen, and 15.9 per cent of ash. The results of this fractionation are summarized in Table I.

If the water-soluble vitamine was wholly concentrated in any one of these fractions quantities of each equivalent to the original yeast from which it was derived should be as effective as the latter in promoting the recovery of young rats declining on a diet free from this accessory. As 0.2 gm. of the entire yeast has proved to be sufficient for this purpose, and 0.1 gm. usually to be insufficient, these fractions were mixed with starch in such proportion as to make the mixture contain the same percentage of the fraction as did the original yeast. Thus 0.2 gm. of the starch-fraction mixtures contained of Fraction I 8.6 mg., II 12.4 mg., III 3.2 mg., IV 8.8 mg. Since Fraction II formed a larger percentage of the yeast than did any of the other fractions the absolute amount of each of these fractions in the respective starch mixtures was less than that of Fraction II. The feeding experiments to be described consequently do not afford a strict comparison of the efficiency of the fractions relatively to one another. They do, however, enable us to determine in which fraction the greater part of the total water-soluble vitamine of the yeast was concentrated. Charts II, III, and IV show the results of such feeding experiments. Chart II (Rats 5191, 5199, and 5291) shows that no appreciable gain of weight was made when doses of Fraction I equivalent to 0.2 gm. of yeast were fed daily. That this fraction was not wholly free from the water-soluble vitamine is shown by the slight gains made by Rats 5191 and 5291 after doubling the dose. When Rat 5199 was given daily doses of Fraction II corresponding to 0.2 gm. of yeast, it gained weight rapidly. Chart III shows that Rats 5116 and 5289 which received daily doses of Fraction II equivalent to 0.2 gm. of yeast gained weight rapidly. Rat 5116 when given 0.2 gm. of yeast grew no faster. Rat 5198 which received a daily dose of Fraction II equivalent to only 0.1 gm. of yeast made a fairly rapid gain of weight although only 6.2 mg. of the fraction were fed. Chart IV shows that Rats 5054 and 5288, to which doses of Fraction III equivalent to 0.2 gm. of yeast were given each day, and Rats 5039 and 5131, to which similar doses of Fraction IV were given, gained so little weight that it is evident that neither of these fractions contained as large a proportion of the water-soluble vitamine of the original yeast as did Fraction II. The slight gain of weight made by the rats having Frac-

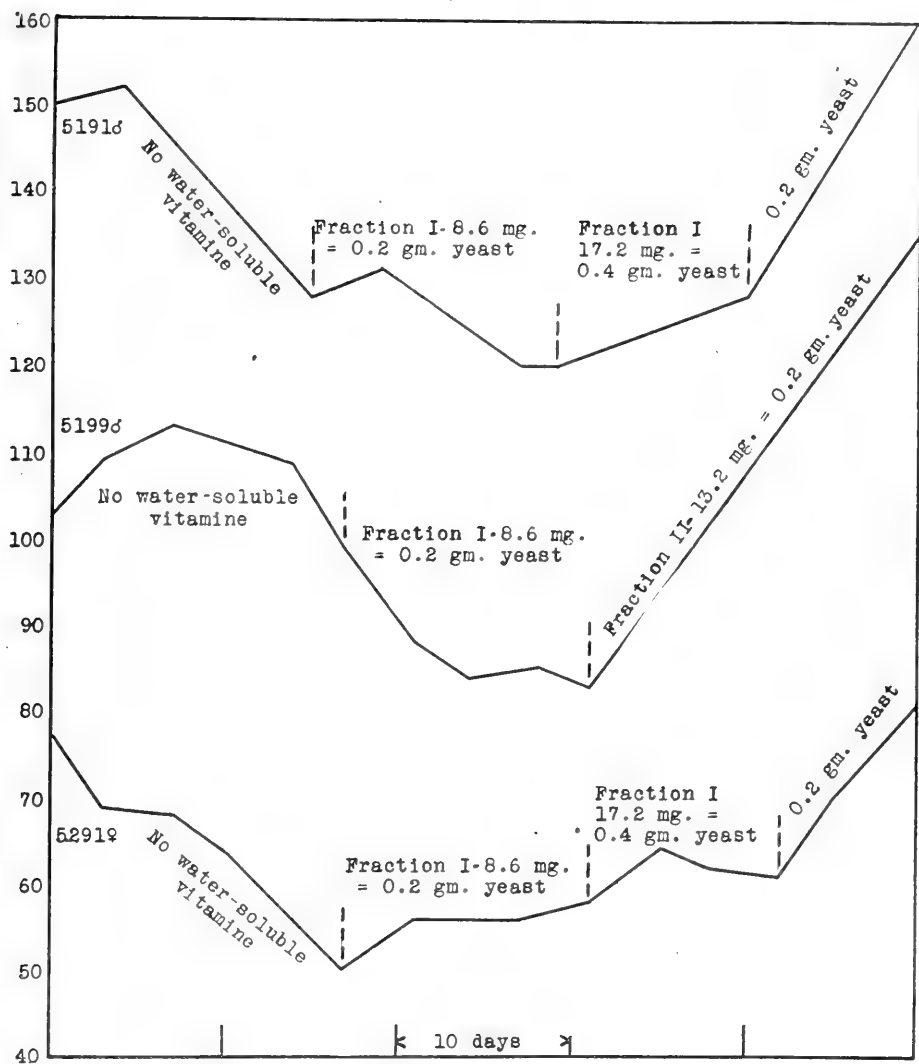

CHART II. Young rats after declining on a diet free from water-soluble vitamins fail to recover when quantities of Fraction I, equivalent to 0.2 gm. of yeast are added daily to their diets, but recover when given similar proportions of Fraction II or 0.2 gm. of yeast. Even doubling the quantity of Fraction I caused very little gain in weight.

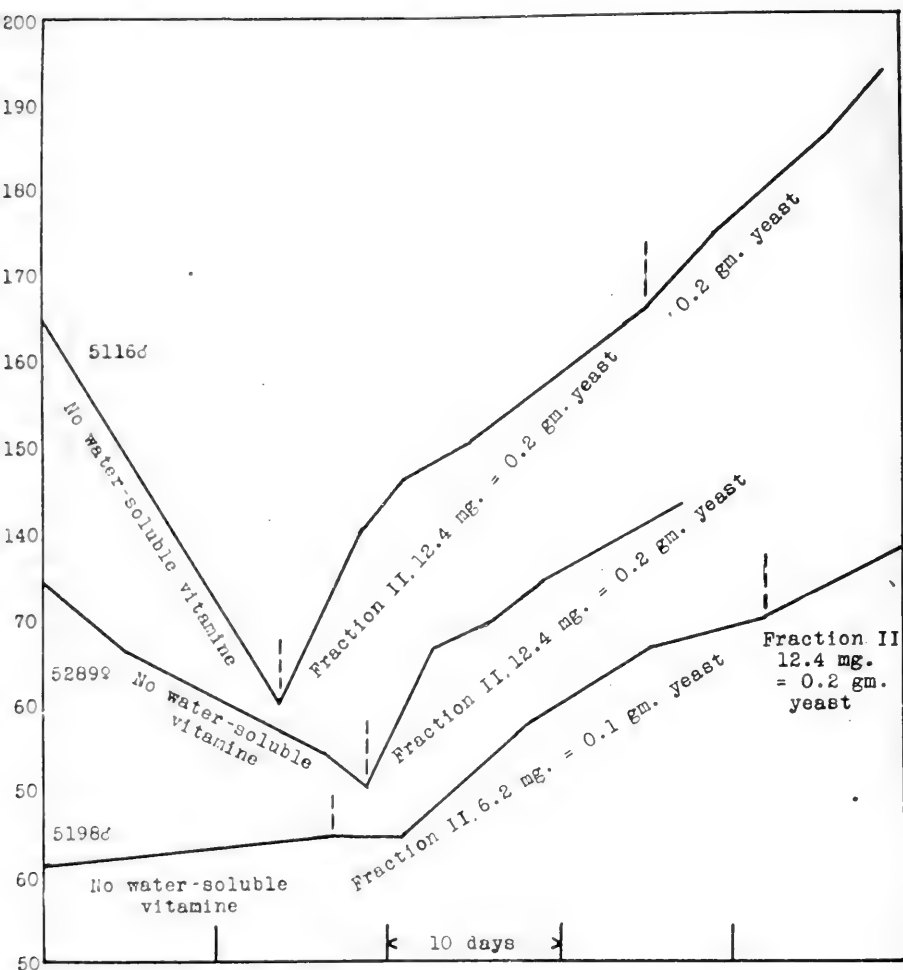

CHART III. Young rats declining on a diet free from water-soluble vitamine recover when given quantities of Fraction II equivalent to 0.2 or 0.1 gm. respectively of yeast. When 0.2 gm. of yeast was given to Rat 5116 in-stead of Fraction II it did not gain any faster.

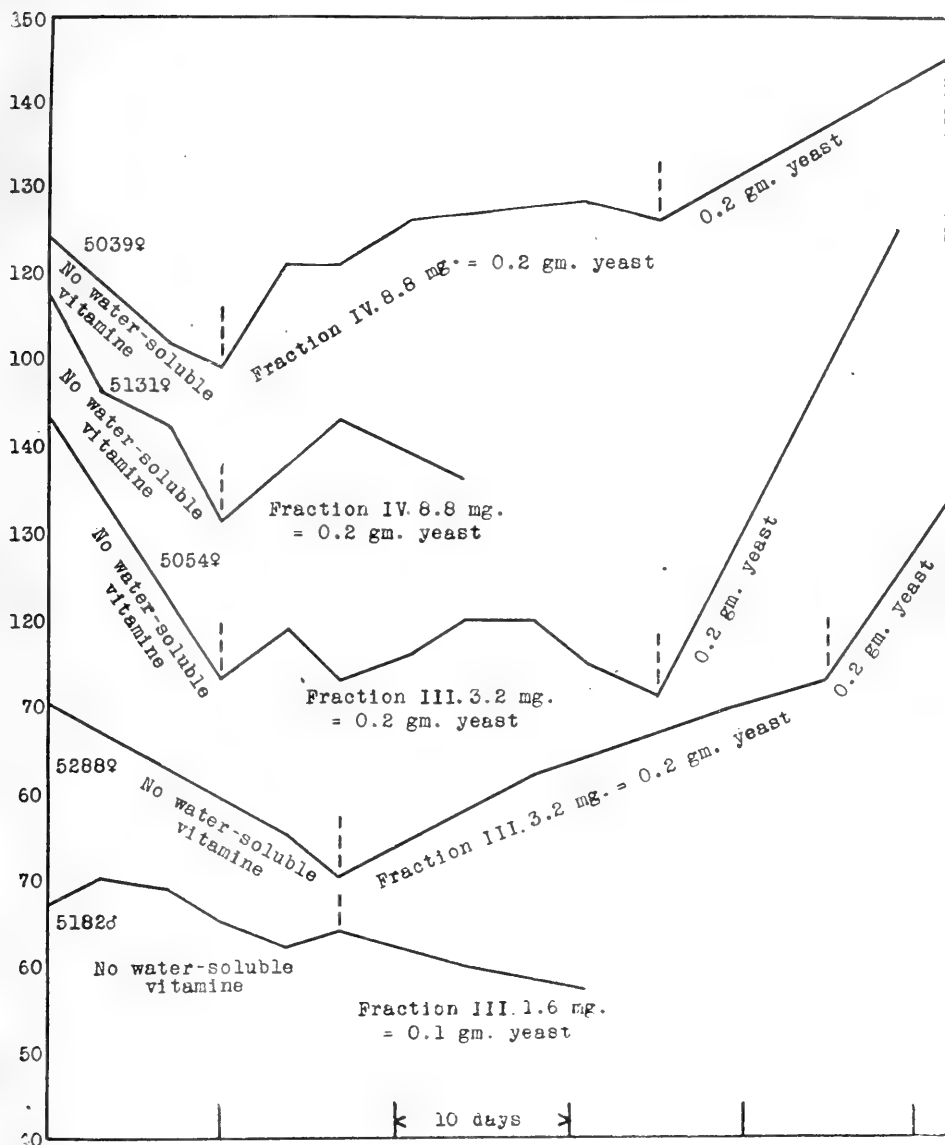

CHART IV. Young rats declining on a diet free from the water-soluble vitamine fail to recover when given quantities of Fractions III or IV equivalent to 0.2 gm. of the original yeast. Recovery is prompt when 0.2 gm. of yeast is given.

tions III and IV indicates, however, that these fractions contained some of the water-soluble vitamine. In view of the fact that daily doses of only 3.2 mg. of Fraction III enabled Rat 5288 to make a relatively considerable gain of weight shows that this fraction contained, weight for weight, as much, if not more, of the water-soluble vitamine as did Fraction II. However, since Fraction III amounted to only 1.6 per cent. of the yeast it contained only a relatively small part of the total water-soluble vitamine. There can be no question therefore that Fraction II contained most of the water-soluble vitamine originally present in the yeast.

Having thus found that the greater part of the water-soluble vitamine can be concentrated in about 6 per cent of the yeast solids it is now possible to supply enough of this vitamine for normal nutrition without introducing such relatively large quantities of nitrogenous substances of unknown nature as have heretofore usually been necessary. Whether the method of fractionation here described is superior to precipitation by adsorption on Lloyd's¹ reagent remains to be determined, but it would seem as if our Fraction II offered advantages for the further study of many problems concerning the water-soluble vitamine. According to Seidell, Lloyd's reagent adsorbs 4.5 per cent of the nitrogen from the autolyzed yeast filtrate simultaneously with the vitamine, whereas our Fraction II contained 4.46 per cent of the total yeast nitrogen or 31.8 per cent of the nitrogen of the yeast extract.

As this Fraction II is easily prepared in large quantities it will certainly afford a better crude material for further study than does the autolyzed yeast filtrate which contains a large proportion of the products of autolysis derived from the yeast protein which, as our experiments show, are not concerned in the activity of vitamine preparations made from yeast. The chief advantage of the procedure here described lies in the preparation of the aqueous extract, for by avoiding autolysis the proportion of water-soluble constituents of the extract is reduced to a minimum while the quantity of water-soluble vitamine in the extract is apparently not diminished.

¹ Seidell, A., *J. Biol. Chem.*, 1917, xxix, 145.

It will be a matter of interest to learn more than is now known about the chemical nature of the constituents of this water extract of the living yeast, not only in connection with further attempts to concentrate the water-soluble vitamine, but also as a contribution to the chemistry of cytoplasm.

As yet we have made only a preliminary examination of this interesting mixture. That it consists chiefly of nitrogenous substances is indicated by its content of about 8.5 per cent of nitrogen. Proteins are not present in amounts detectable by saturating with ammonium sulfate, or by potassium ferrocyanide and acetic acid. A biuret reaction has been obtained only by very carefully applying this test to the part precipitated by 52 per cent alcohol. Inorganic constituents are also abundant, because the ash forms over 20 per cent of the dry solids. The different types of nitrogen in the water extract in percentage of the total nitrogen are shown in Table II.

TABLE II.
Types of Nitrogen in Per Cent of Total Nitrogen.

	Humus N.	NH ₃ N.	NH ₂ N.	Basic N.	Purine N.
Before hydrolysis.....	0	0	42	50	0
After "	0.64	1.56	60	50	18

The above figures indicate the presence of relatively large proportions of nucleic acid, amino-acids, and peptides, but as yet none of these has been isolated. Phosphatides are probably absent, because the ether extracts from Fractions II, III, and IV, the latter soluble in strong alcohol, failed to give any precipitate when poured into acetone.

Fraction II which contains most of the water-soluble vitamine presents greater interest than the aqueous extract. This fraction is very soluble in water, its solution being distinctly acid to litmus. Relatively considerable quantities of alkali are needed to produce a neutral reaction to litmus and not a little more must be added before an alkaline reaction results. Only a trace of a precipitate separates from the neutralized solution.

The unneutralized solution gives a large precipitate with lead acetate. Barium chloride causes only a turbidity, but yields an

abundant precipitate when the solution is previously neutralized with sodium hydroxide. Silver nitrate does likewise.

Baryta solution gives a voluminous precipitate which contains about 25 per cent of the solids of the fraction and a relatively small part of its nitrogen. About 25 per cent more of the fraction is thrown out of the alkaline filtrate from the barium precipitate by silver nitrate. This precipitate, when thoroughly washed with baryta solution, contains nearly one-half the nitrogen of the fraction. The aqueous solution of Fraction II when acidified with sulfuric acid yields a very large precipitate with phosphotungstic acid. Mercuric chloride gives a precipitate; copper sulfate gives none. An aqueous or alcoholic solution of picric acid gives a precipitate if enough is added. Whether any one of the above precipitates contains some or all of the water-soluble vitamine remains to be determined.

Such preliminary observations indicate that a variety of substances are present in this fraction, but give no clue to the nature of the water-soluble vitamine. We have provided ourselves with several kilos of this active yeast fraction and are now engaged in a systematic study of its constituents.

CRYSTALLINE SALTS OF URIDINPHOSPHORIC ACID.

By P. A. LEVENE.

(From the Laboratories of The Rockefeller Institute for Medical Research.)

(Received for publication, October 31, 1919.)

Uridinphosphoric acid was previously described in form of its crystalline brucine and barium salts.¹ The identification of a nucleotide in form of its brucine salts was found not sufficiently reliable. The crystallization of the barium salt of uridinphosphoric is a slow and tedious process. Hence it was desirable to find such salts of the nucleotide which could be crystallized with readiness when one is in possession even of only a small quantity of material. In this communication are described several such salts; namely, the mono- and the diammonium salts of uridinphosphoric acid, the neutral lead salt, and the brucine salt prepared from the crystalline ammonium salt.

The neutral ammonium salt is readily prepared from the brucine salt and crystallizes as heavy, elongated prisms. In aqueous solution its optical rotation is $[\alpha]_D^{20} = +21.0$. It crystallizes with one crystal water.

The mono-basic salt crystallizes in form of long, prismatic needles. It is very soluble in cold and hot water, and in hot glacial acetic acid. In aqueous solution it has an optical rotation of $[\alpha]_D^{20} = +13.0$. The air-dry substance contains no crystal water.

The neutral lead salt crystallizes in long needles, and was found very useful in obtaining pure uridinphosphoric acid when the original brucine salt had not been sufficiently purified.

The brucine salt was prepared in order to establish the constants of the compounds, since there was no conclusive evidence as to the absolute purity of the brucine salt obtained on fractionation of the mixed brucine nucleotides derived from the products of hydrolysis of nucleic acid.

¹ Levene, P. A., *Proc. Soc. Exp. Biol. and Med.*, 1917, xv, 21; *J. Biol. Chem.*, 1918, xxxiii, 229.

EXPERIMENTAL.

Di-basic ammonium salt was prepared by decomposing with aqueous ammonium hydroxide a solution of the brucine salt of uridinphosphoric acid in 35 per cent alcohol. The brucine salt of the mononucleotide was obtained either on acid or on ammonia hydrolysis of yeast nucleic acid.

The crude ammonium salt was dissolved in a minimum volume of hot water and to the solution hot methyl alcohol was added to very slight opalescence. On standing over night a deposit of heavy crystals formed. In subsequent experiments crystallization began immediately after addition of alcohol, if the solution was seeded with a crystal of the pure substance. The substance decomposed at 185°C. (uncorrected).

0.0994 gm. of the substance gave 0.1048 gm. of CO₂ and 0.0486 gm. of H₂O.

0.1000 gm. of the substance analyzed for Kjeldahl nitrogen estimation required 10.68 cc. of 0.1 N acid.

0.3000 gm. of the substance gave 0.0870 gm. of Mg₂P₂O₇.

	Calculated for C ₉ H ₁₉ N ₄ PO ₇ + $\frac{1}{2}$ H ₂ O. per cent	Found. per cent
C.....	29.11	28.75
H.....	5.42	5.47
N.....	15.22	14.95
P.....	8.44	8.08

The optical rotation of the substance was as follows.

$$[\alpha]_D^{20} = \frac{+ 0.42 \times 100}{1 \times 2} = + 21.0$$

Mono-basic ammonium salt was prepared in the following way: 2.0 gm. of the neutral salt were dissolved in 15.0 cc. of glacial acetic acid, and to the hot solution hot ethyl acetate was added dropwise. Care was taken to wait with further addition until the precipitate forming on contact of ethyl acetate with the solution had disappeared. After a slight opalescence was established, the solution was allowed to stand over night. A crystalline sediment was found in form of balls consisting of long needles. In subsequent experiments, if the solution in glacial acetic was seeded with the pure substance, crystallization began immedi-

ately. The air-dry substance contracted at 210°C. (corrected) and decomposed at 242°C. (corrected).

0.1000 gm. of the substance gave 0.1142 gm. of CO₂ and 0.0452 gm. of H₂O.

0.1000 gm. of the substance employed for Kjeldahl nitrogen estimation required for neutralization 8.8 cc. of 0.1 N acid.

0.3000 gm. of the substance gave 0.0943 gm. of Mg₂P₂O₇.

	Calculated for C ₉ H ₁₈ N ₃ PO ₉ . per cent	Found. per cent
C.....	31.66	31.14
H.....	4.73	5.05
N.....	12.32	12.32
P.....	9.09	8.76

The optical rotation of the aqueous solution was as follows.

$$[\alpha]_D^{20} = \frac{+ 0.26 \times 100}{1 \times 2} = + 13.0$$

Neutral lead salt was prepared in the following way: 2.0 gm. of the neutral ammonium salt were dissolved in 50 cc. of water; to the solution 10 cc. of glacial acetic acid were added, and to the hot solution of the nucleotide a hot solution of neutral lead acetate was added. Immediately a gelatinous precipitate formed which, on boiling, disappeared nearly completely. The solution was filtered and seeded with a few crystals obtained from a test-tube experiment. Crystallization in long needles began immediately. The crystals once formed are very little soluble in boiling water.

Dried to constant weight the substance had the following composition.

0.1070 gm. of the substance gave 0.0788 gm. of CO₂ and 0.0206 gm. of H₂O.

0.1856 gm. of the substance employed for Kjeldahl nitrogen estimation required for neutralization 6.90 cc. of 0.1 N acid.

0.2782 gm. of the substance gave 0.0573 gm. of Mg₂P₂O₇.

	Calculated for C ₉ H ₁₁ N ₃ PO ₉ Pb. per cent	Found. per cent
C.....	20.40	20.08
H.....	2.10	2.21
N.....	5.29	5.21
P.....	5.86	5.74

Brucine Salt of Uridinphosphoric Acid.—About 4.0 gm. of the neutral ammonium salt were converted into the lead salt. This was freed from lead by means of hydrogen sulfide and the brucine salt was obtained in the usual way. The salt was recrystallized twice, each time out of 1,500 cc. of 35 per cent alcohol.

The air-dry substance effervesced without becoming transparent at 185°C. (corrected) and contracted and melted without further decomposition at 195°C. (corrected).

The air-dry substance had the following composition.

0.0996 gm. of the substance gave 0.1948 gm. of CO₂ and 0.0591 gm. of H₂O.

0.2000 gm. of the substance gave 12.8 cc. of nitrogen gas at T° = 24°C., at P = 759 mm.

0.3000 gm. of the substance gave 0.0270 gm. of Mg₂P₂O₇.

	Calculated for C ₁₁ H ₁₃ N ₇ PO ₄ (C ₂₃ H ₂₇ N ₃ O ₄) ₂ +7H ₂ O.	Found.
	<i>per cent</i>	<i>per cent</i>
C.....	53.30	53.33
H.....	6.43	6.64
N.....	6.79	7.35
P.....	2.50	2.51

The rotation of the substance, owing to the insolubility of the substance, was taken in great dilution, and was as follows.

$$[\alpha]_D^{20} = \frac{-0.16 \times 100}{2 \times 0.4} = -20.0$$

ON THE IDENTITY OF THE WATER-SOLUBLE GROWTH-PROMOTING VITAMINE AND THE ANTINEURITIC VITAMINE.

BY H. H. MITCHELL.

(From the Department of Animal Husbandry, University of Illinois, Urbana.)

(Received for publication, October 13, 1919.)

The vitamine requirements of animals have been investigated along two distinct lines; *i.e.*, (1) through a study of the nutritive deficiencies of rations containing only known chemical compounds, and (2) through a study of the prevention and cure of certain diseases definitely referable to faulty diet. By the first line of investigation it has been repeatedly demonstrated that, besides the well known constituents of plant and animal tissues, the higher mammals require for the maintenance of health, and even of life, and for the production of normal growth small amounts of substances of unknown composition, more or less widely distributed throughout natural food products. At least two such substances are required. One is associated with certain animal fats and fresh leafy vegetables especially, and variously referred to as the fat-soluble vitamine or growth-promoting substance, or as fat-soluble A, a convenient abbreviated term introduced by McCollum and Kennedy, which unfortunately has not the general currency that it deserves. The other growth-promoting substance is never associated with fats, but is especially rich in the glandular tissues of animals, hens' eggs, the embryos of seeds, and the leaves of plants. It is spoken of as the water-soluble growth-promoting vitamine or as water-soluble B (McCollum). Any assertion that the common sources of either of these vitamins contain only one indispensable substance is based purely upon circumstantial evidence.

By the second line of investigation it has been shown with reasonable certainty that there are at least two diseases referable to faulty diet, the cause of which, in each case, is a deficiency in

the diet of an unknown substance associated with natural food products. These two diseases, beri-beri and scurvy in man (or polyneuritis in pigeons and scurvy in guinea pigs), are "deficiency diseases" in the sense that they may result when an animal subsists on food containing all the known and well recognized constituents of a complete diet, and may be cured, except for serious organic lesions, by adding to such a diet small amounts of extracts of certain natural food products. The unknown substances involved in the production of these two deficiency diseases have been called the antineuritic vitamine and the antiscorbutic vitamine, respectively, and their distribution in plant and animal tissues, their solubilities, and chemical properties have been the subject of a large amount of research. Besides these two deficiency diseases, no others are generally recognized as such. A condition of sore, inflamed eyes, which, according to McCollum, should be diagnosed as xerophthalmia, often results from a deficiency of sources of fat-soluble A in the diet. While McCollum definitely classifies this condition as a deficiency disease, it does not seem to be generally recognized as such, and a reasonable doubt may exist as to whether it invariably results from a deficiency of fat-soluble A and whether its etiology does not involve an infection avoidable by exercising proper sanitary measures alone.¹

It is evident that the numerous recent investigations on vitamins that have been undertaken by many workers, especially in America and England, have seriously complicated the problem of the nutritive requirements of animals. Any experimental evidence that would simplify this situation would therefore be doubly welcome. However, an undue simplification, based upon insufficient evidence, would lead to confusion and might seriously impede progress. One possibility that would simplify matters would be a clear-cut demonstration that two or more of these vitamins are in fact identical. That fat-soluble A and water-soluble B are identical, or that the antineuritic and antiscorbutic vitamins are identical, may be ruled out at once on the evidence at present available. However, the identity of water-soluble B and the antineuritic vitamine is a possibility not definitely dis-

¹ Bulley, E. C., *Biochem. J.*, 1919, xiii, 103.

posed of in this summary manner. In fact, the belief exists in many quarters that such an identity exists. This belief ranges from positive conviction, through tacit acceptance, to a frank weighing of probabilities. On the one hand is the statement of McCollum and his coworkers that: "Xerophthalmia and polyneuritis are abundantly demonstrated to have their origin in the lack of a sufficient amount of the fat-soluble A and water-soluble B respectively in the diet."² Evidently as the result of this unequivocal attitude of McCollum, some investigators use the terms "water-soluble B" and "antineuritic vitamine" interchangeably. Osborne and Mendel are more conservative: "Whether or not the antineuritic component [of yeast] is identical with the growth-promoting one is a question which as yet has received no definite answer. . . ."³ Again, after referring to studies of the protective, curative, or antineuritic properties of certain animal tissues, they say: "That the substance which induces the remarkable recoveries which have been described in these cases is identical with the water-soluble hormone which is so essential for growth and maintenance is as yet merely a matter of conjecture."⁴

In view of the importance of the question of the identity of these two vitamins, one essential for the maintenance of life and growth, the other for the prevention of multiple neuritis, and in view of the lack of general acceptance of the affirmative statement of McCollum and coworkers, a somewhat searching critical consideration of the evidence may render a real service in clarifying the issue and indicating the most likely points of future attack.

The conclusion that the two vitamins are identical seems to be based upon the following grounds. (1) The distribution of the two substances in natural food products is very similar and the correlation between the actual amounts (in as far as these have been measured by biological tests) found in different products appears to be close. (2) The lack of known sources of water-soluble B in the diet of various species of experimental animals

² McCollum, E. V., Simmonds, N., and Parsons, H. T., *J. Biol. Chem.*, 1918, xxxiii, 413.

³ Osborne, T. B., and Mendel, L. B., *J. Biol. Chem.*, 1917, xxxi, 154.

⁴ Osborne, T. B., and Mendel, L. B., *J. Biol. Chem.*, 1917, xxxii, 311.

seems generally, if not always, to result in symptoms of nerve degeneration and paralysis. (3) Extracts of natural food products possessing growth-promoting properties are said to contain very probably only one indispensable vitamine, though supplementing satisfactorily a ration containing no other possible source of antineuritic vitamine. (4) The solubilities of the two vitamins in the common solvents are said to be identical. (5) Attempts at isolating the two vitamins have shown that they possess identical precipitants and adsorbents. (6) The stabilities of the two substances, especially to acids, alkalis, and elevated temperatures, seem to be similar if not identical.

Critical analyses of these points are presented in order.

1. While the distribution of the two vitamins among natural food products is strikingly similar in many respects, there are some instances where the correlation is not close. Through the work of Osborne and Mendel,⁵ it has been shown that green vegetables, such as cabbage and spinach, are rather rich sources of water-soluble B, compared, for example, with the whole cereal grains. McCollum and Kennedy,⁶ however, have found that cabbage contains the antineuritic factor in "a quite low concentration," a conclusion confirmed by some recent work of Chick and Hume.⁷ These investigators have concluded from experiments on the relative vitamine content of a large range of different foodstuffs that fresh and desiccated vegetables, including the cabbage, onion, and carrot, are poor sources of the antineuritic vitamine as compared with whole wheat, being about on a par with fresh meat. Fresh meat is known to be a poor source of both water-soluble B and the antineuritic vitamine,⁸ but, on the other hand, the carrot seems to be rich in water-soluble B,⁹ though poor in antineuritic vitamine. Again, Chick and Hume have found the potato to have a very low content of antineuritic vitamine, having practically no value as a preventive against avian

⁵ Osborne, T. B., and Mendel, L. B., *J. Biol. Chem.*, 1919, xxxvii, 187.

⁶ McCollum, E. V., and Kennedy, C., *J. Biol. Chem.*, 1916, xxiv, 496.

⁷ Chick, H., and Hume, E. M., *Tr. Soc. Trop. Med. and Hyg.*, 1916-17, x, 156

⁸ Osborne, T. B., and Mendel, L. B., *J. Biol. Chem.*, 1917, xxxii, 309. Cooper, E. A., *J. Hyg.*, 1912, xii, 436; 1914, xiv, 12.

⁹ Sugura, K., and Benedict, S. R., *J. Biol. Chem.*, 1918, xxxvi, 171, 191.

polyneuritis, a result confirmed by Vedder and Clark,¹⁰ though McCollum and Kennedy claim that potato juice possesses a moderate curative power. As regards its content of water-soluble B, however, McCollum, Simmonds, and Parsons¹¹ have shown that the potato, when constituting 84.5 per cent of the ration of rats, provides enough of this vitamine for normal growth. Chamberlain, Vedder, and Williams¹² found water extract of onions to have no curative effect on polyneuritic pigeons, though Osborne and Mendel¹³ discovered considerable water-soluble B in this food as well as in turnips, beets, and tomatoes.

The green vegetables, and roots and tubers seem in general, therefore, to contain rich or moderate amounts of the growth-promoting water-soluble vitamine, and small amounts or none at all of the antineuritic vitamine. If this relation is abundantly confirmed by future research, it may of itself effectively dispose of any contention of the identity of the two vitamines. The evidence as it stands, however, does not amount to finality for several reasons. Much recent work has shown that the vitamine content of fresh vegetables, and roots and tubers is extremely variable, depending apparently on the freshness and maturity of the material. No experiments appear to have been carried out on the antineuritic and the growth-promoting properties of the same vegetable samples. Again, the experimental polyneuritis of pigeons is almost invariably induced by a diet of polished rice in investigations on the comparative antineuritic properties of foods. Polished rice, however, is defective in several factors besides the antineuritic factor. It is therefore probable that foods containing comparable amounts of this vitamine may be unequally effective in preventing or curing the polyneuritic symptoms, depending upon the extent to which they supplement polished rice in these other respects. Conversely, foods containing unequal concentrations of the antineuritic principle may have their relative values as sources of the vitamine distorted for

¹⁰ Vedder, E. B., and Clark, E., *Philippine J. Sc., Section B*, 1912, vii, 423.

¹¹ McCollum, E. V., Simmonds, N., and Parsons, H. T., *J. Biol. Chem.*, 1918, xxxvi, 208.

¹² Chamberlain, W. P., Vedder, E. B., and Williams, R. R., *Philippine J. Sc., Section B*, 1912, vii, 45.

¹³ Osborne, T. B., and Mendel, L. B., *J. Biol. Chem.*, 1919, xxxix, 29.

the same reason. The argument is illustrated by the experience of Campbell and Chick with scorbutic rations.¹⁴ A ration of oats, bran, and water produces death from scurvy in guinea pigs in 3 to 4 weeks. However, the addition of 60 cc. of autoclaved milk, a food containing no demonstrable antiscorbutic value, delays the onset of scurvy from 1 to 3 weeks, evidently simply by correcting the deficiencies of the basal ration in factors other than the antiscorbutic.

Further evidence, out of harmony with the assumption that water-soluble B and the antineuritic vitamine are identical, is afforded by experiments on unpolished rice. McCollum and Davis¹⁵ have shown reason to believe that unhusked rice is adequately supplemented by casein, salts, and butter fat, similar to the other cereal seeds. Gibson and Concepcion,¹⁶ however, report experiments on pigeons indicating an incomplete protection against polyneuritis afforded by an exclusive diet of unhusked rice. Six fowls were fed on palay (unhusked rice), three for 2 months, two for 3 months, and one for 4 months. While they developed no symptoms of neuritis in this time, on postmortem examination, the sciatic nerves showed distinct degenerative changes in every case on being stained by the Marchi method. The degeneration corresponded to that obtained with birds fed for 2 weeks or more on milled rice. In fact, the degeneration in two of the birds was more pronounced than can be observed in some subjects that have died of rice polyneuritis. In the case of man, also, analogous results have been reported.¹⁷

2. The lack of known sources of water-soluble B in the diet of rats has frequently been said to result in symptoms of paralysis of the hind legs, and the conclusion has been drawn that a well defined neuritis existed. Such symptoms, however, are not universally noted as a result of subsistence on rations totally lacking in water-soluble B,¹⁸ and the conclusion that they invariably

¹⁴ Campbell, M. E. D., and Chick, H., *Lancet*, 1919, ii, 320.

¹⁵ McCollum, E. V., and Davis, M., *J. Biol. Chem.*, 1915, xxiii, 230.

¹⁶ Gibson, R. B., and Concepcion, I., *Philippine J. Sc.*, Section B, 1914, ix, 119.

¹⁷ Strong, R. P., and Crowell, B. C., *Philippine J. Sc.*, Section B, 1912, vii, 414. Shibayama, *J. Trop. Med. and Hyg.*, 1913, xvi, 284.

¹⁸ Osborne, T. B., Wakeman, A. J., and Ferry, E. L., *J. Biol. Chem.*, 1919, xxxix, 35.

develop cannot be verified. Even when animals do develop such symptoms it does not seem to be specific to a deficiency of this vitamine. Hart, Miller, and McCollum¹⁹ report experiments on pigs on a large number of rations, leading in many cases to paralysis of the hind quarters, and, as brought out by the histological examination of sections of the spinal cord, to marked edema and degeneration of the motor cells. They conclude from this work:

“Malnutrition, histologically characterized by nerve degeneration, may result from the absence of certain factors in the diet as in the case of beri-beri. A similar condition may likewise arise from the presence of toxic materials in apparently normal food products, and in the presence of all known factors essential for continued growth and well-being.”

It can hardly be contended, therefore, that the appearance of neuritic conditions in experimental animals is an unequivocal indication of a deficiency in antineuritic vitamine.

3. The existence of two indispensable unknown substances in water and alcohol extracts of natural foods is doubted by McCollum and Simmonds²⁰ on the basis of the following evidence.

“In the experimental part of this paper it is shown that the water-soluble B is not extracted directly from beans, wheat germ, or pig kidney by ether, benzene, or acetone, but is readily extracted in great part by alcohol. After being removed by alcohol it is shown to be soluble in benzene, but very slightly soluble in acetone. The probability that there should be two or more physiologically indispensable substances in what we term water-soluble B, both or all of which should show the same solubility relations with three solvents, is relatively small and lends support to our view that the substance which protects animals against polyneuritis is the only essential complex in the extracts described.”

While the argument is directed particularly against the theory that scurvy is a deficiency disease, it is just as forceful against any theory that water-soluble B and the antineuritic vitamine are not one and the same thing. Thus, McCollum's theory of the nutritive requirements of animals, which, because of its simplicity and the unequivocal terms in which it is stated, has

¹⁹ Hart, E. B., Miller, W. S., and McCollum, E. V., *J. Biol. Chem.*, 1916, xxv, 239.

²⁰ McCollum, E. V., and Simmonds, N., *J. Biol. Chem.*, 1918, xxxiii, 62.

gained many advocates, has no room for two vitamins possessing the solubilities of water-soluble B. The argument is not particularly impressive, being entirely of a circumstantial character. In fact, it is quite conceivable that the treatment of natural foods with boiling alcohol breaks up combinations of vitamins with other substances, so that removal of the water-soluble B by this solvent may have been a combination of chemical and purely solvent action. A crucial experiment that would dispose of this possibility would have been to boil the food with alcohol in a reflux condenser for a short time only, evaporate off the alcohol, and then test with acetone and benzene for extraction of the active substance.

4. The solubilities of the water-soluble B and the antineuritic vitamin are very largely similar. Both are soluble in water and dilute alcohol and are ordinarily stated to be insoluble in fat solvents. Solubility in absolute alcohol is variously stated for both substances. Osborne and Mendel, and Drummond²¹ claim that the water-soluble growth-promoting substance of yeast is insoluble in absolute alcohol, and McCollum and Simmonds²⁰ have found it to be only incompletely soluble in 95 per cent alcohol. On the other hand, Eijkman²² claims that the antineuritic substance of yeast is extracted by strong alcohol. The neuritic curative substance of rice polishings has been repeatedly extracted by Funk²³ and Fraser and Stanton²⁴ by absolute alcohol and appears to be readily soluble in this reagent. Cooper⁸ has also shown that the antineuritic vitamin of dried beef is extracted by absolute alcohol, and that the constituent of egg yolk that cures polyneuritis in pigeons is readily extractable with ether²⁵ from the dried yolk. After extraction with ether, a further yield was obtained from the residue by means of absolute alcohol.

While the evidence for the solubility of the two vitamins in alcohol is incomplete and somewhat conflicting, though lending

²¹ Osborne, T. B., and Mendel, L. B., *J. Biol. Chem.*, 1917, xxxi, 158.
Drummond, J. C., *Biochem. J.*, 1917, xi, 261.

²² Eijkman, C., *Arch. Schiffs- u. Tropenhyg.*, 1911, xv, 698.

Funk, C., *J. Physiol.*, 1911-12, xliii, 395.

²⁴ Fraser, H., and Stanton, A. T., *Lancet*, 1910, ii, 1755.

²⁵ McCollum and his coworkers have repeatedly shown that water-soluble B is not extracted by ether from food materials.

support to the conclusion that the growth-promoting factor is considerably less soluble than the antineuritic, some clear-cut evidence exists of a distinct difference in solubility in acetone and benzene, mainly from the work of McCollum and his associates. Thus, McCollum and Kennedy²⁶ conclude from many experiments on the curative properties of various extracts of wheat embryo for polyneuritic pigeons that acetone and benzene extract from this material, previously rendered fat-free by extraction with ether, the substance which relieves the symptoms of polyneuritis in pigeons. Alcohol (95 per cent), water, acetone, and benzene extracts of fat-free wheat embryo were all shown to be capable of curing polyneuritic pigeons, and, as far as can be judged from the protocols of the experiments, the cure was just about as readily accomplished with acetone and benzene extracts as with alcohol and water extracts. At most, the superiority of the latter was slight.

Entirely different results were obtained by McCollum and Simmonds²⁷ in later investigations on the solubility of water-soluble B. In investigating the growth-promoting properties of extracts of raw and cooked navy beans, wheat embryo, and pig kidney added to a basal ration deficient only in water-soluble B, they were able to show that acetone and benzene do not extract the water-soluble B from these products to any appreciable extent. Slight indications that the acetone extract carried traces of this vitamine were encountered, but they were still led to believe that most of the substance remained in the residue. This work confirmed some previous work by McCollum and Davis²⁸ on the supplementary action of acetone extracts of wheat embryo on polished rice. After extraction of the water-soluble B by alcohol, it was found by McCollum and Simmonds to be only slightly soluble in acetone, and many times more soluble in benzene.

²⁶ McCollum, E. V., and Kennedy, C., *J. Biol. Chem.*, 1916, xxiv, 491.

²⁷ McCollum, E. V., and Simmonds, N., *J. Biol. Chem.*, 1918, xxxiii, 55.

²⁸ McCollum, E. V., and Davis, M., *J. Biol. Chem.*, 1915, xxiii, 229, 230.

This investigation and the preceding one are open to the criticism that no food intake records are given in order that the reader may judge whether a change in ration was effective by reason of a difference in food intake or of a difference in food composition, and also that the experimental periods were often too short to indicate any effect at all.

Recently Steenbock²⁹ has reported that by means of neutral solvents there was prepared a water-acetone-soluble fraction from egg yolk which in small doses by intraperitoneal injections was able to cure a pigeon suffering from polyneuritis.

From the work quoted, therefore, the evidence lends support to the conclusion that the water-soluble B is not extracted from food materials to any appreciable extent by either acetone or benzene, and that when extracted it is still only slightly soluble in acetone, though readily soluble in benzene. The antineuritic vitamine, however, seems to be readily extracted from wheat embryo by acetone and benzene, and to be readily soluble in both of these solvents.

5. Attempts to isolate the antineuritic vitamine from rice polishings and yeast have been much more numerous and have given more definite results than similar attempts with the water-soluble B. The antineuritic vitamine has been shown to be quantitatively precipitated by phosphotungstic acid in 5 per cent sulfuric acid solution, giving a phosphotungstate insoluble in acetone. It is also completely precipitated by silver nitrate and barium hydroxide, only partially precipitated by mercuric chloride, and is not precipitated by platinic chloride. It is quantitatively adsorbed by animal charcoal, fullers' earth, and by hydrated aluminium silicate (Lloyd's reagent). The antineuritic vitamine is also dialyzable.

Funk and Macallum³⁰ have attempted a similar fractionation of the water-soluble B from yeast with indifferent success. They showed that phosphotungstic acid precipitated the growth-promoting substance, and that the filtrate from this precipitation was inactive. However, only a small fraction of the growth-promoting capacity of the yeast was found to have survived this precipitation. Subsequent decomposition of the precipitate and reprecipitation with silver nitrate and baryta precipitated a fraction, whose growth-promoting effect was "not sufficiently marked to encourage further investigation." Lloyd's reagent was also used as a precipitant without much success, as the rats on the filtrate also showed increments in growth. According to the authors:

²⁹ Steenbock, H., *J. Biol. Chem.*, 1917, xxix, p. xxvii.

³⁰ Funk, C., and Macallum, A. B., *J. Biol. Chem.*, 1916, xxvii, 63.

"The results obtained so far clearly indicate that the growth-promoting substance is analogous to and possibly identical with the beri-beri vitamine. . . . However, it must be admitted that while it is uncertain whether these two substances are chemically different, the results obtained do not exclude such a possibility."

Eddy³¹ showed that the water-soluble portion of the alcoholic extract of sheep pancreas contains a substance capable of inducing marked increase in growth when added to a ration very low, if not lacking, in vitamins. This substance was removed from the extract with Lloyd's reagent, though the completeness of removal was not tested. It was also precipitated by phosphotungstic acid. A criticism of the work of Funk and Macallum and of Eddy is that the basal ration used in making the biological tests, besides their deficiency of water-soluble B, could not have contained more than a trace of fat-soluble A.

A more extensive and better planned experiment was reported by Drummond,³² investigating the water-soluble B from yeast. Drummond was able to show that the growth-promoting substance is dialyzable. From the dialysate phosphotungstic acid precipitated a fraction possessing very slight growth-promoting activity, while the unprecipitated fraction possessed none. The distinction between the two fractions was slight and in the absence of food intake records is not susceptible of unequivocal interpretation. In another experiment, better growth curves were obtained when the fraction represented by the phosphotungstic acid insoluble in acetone was used than when that contained in the phosphotungstic acid soluble in acetone was used. Even smaller differences were observed between the growth curves of these two groups, however, than in the preceding experiment. Upon fractionation of yeast dialysate with silver nitrate and baryta, the precipitate produced with silver nitrate (purine fraction) had no effect on growth, while that produced on the further addition of baryta (pyrimidine fraction) contained small traces of vitamine.

While Drummond's results support the view that water-soluble B and the antineuritic vitamine are identical, they do not constitute a demonstration. The lack of food intake records complicates their interpretation, while the large losses of vita-

³¹ Eddy, W. H., *J. Biol. Chem.*, 1916, xxvii, 113.

³² Drummond, J. C., *Biochem. J.*, 1917, xi, 255.

mine as soon as precipitation was resorted to finds no parallel in analogous work with the antineuritic substance. For example, Funk showed that the water solution of an alcoholic extract of rice polishings when tested on pigeons suffering from polyneuritis was effective in doses corresponding to about 20 gm. of the original polishings. On precipitation of the solution with phosphotungstic acid, decomposition of the precipitate with baryta, precipitation of the excess barium with sulfuric acid, neutralization and evaporation *in vacuo*, and extraction of the residue with absolute alcohol, the extract was found to be effective as a curative for polyneuritic pigeons in doses corresponding to about 40 gm. of the original polishings. This would indicate a loss of some 50 per cent in antineuritic efficiency, a much smaller loss than seems to result with water-soluble B, even when the manipulations after the phosphotungstic acid precipitation are simplified by decomposing the precipitate with an amyl-alcohol-ether mixture, and eliminating the absolute alcohol extraction. The ready adsorption of water-soluble B by precipitates of all descriptions postulated by Drummond, in explaining the large losses during chemical manipulation, does not seem to be a property of the antineuritic vitamine. Thus, Emmett and McKim³³ show that while this vitamine is adsorbed by fullers' earth and Lloyd's reagent it is not adsorbed by the kieselguhrs or infusorial earths, indicating a selective adsorption by the former. Being readily dialyzable, there seems to be no compelling reason for believing it to be indiscriminately adsorbed by precipitates of all kinds.

6. The stability of both water-soluble B and the antineuritic vitamine to acids seems to be great. Even boiling the vitamins with concentrated mineral acids does not seem to destroy them to any appreciable extent, though some results reported by Drummond³² may be interpreted as indicating a partial destruction of water-soluble B by boiling with 20 per cent sulfuric acid for 10 hours, a result not in harmony with the work of Funk on antineuritic vitamine. Both vitamins seem to be stable to even concentrated alkalis at room temperature.³¹ At the boiling tempera-

³³ Emmett, A. D., and McKim, L. H., *J. Biol. Chem.*, 1917, xxxii, 409.

³¹ The conclusion of Fraser and Stanton (Fraser, H., and Stanton, A. T., *Lancet*, 1915, i, 1021), to the effect that exposure of antineuritic preparations to 0.5 per cent sodium hydroxide at room temperature very quickly destroyed their curative properties for polyneuritic pigeons, has not been confirmed by recent investigations.

ture the antineuritic vitamine seems to be very rapidly destroyed by alkalis,²⁹ though experiments on this point are too few to warrant drawing definite conclusions. Water-soluble B does not seem to be destroyed particularly rapidly by dilute alkalis at high temperatures. While Drummond³² found that hot 5 per cent sodium hydroxide in 5 hours tends to destroy the growth-promoting properties of yeast preparations, Osborne, Wakeman, and Ferry¹⁸ were unable to detect the slightest destruction of this vitamine in dry brewers' yeast after digesting for 21.5 hours with 0.1 \times sodium hydroxide and subsequently heating on the water bath for 2 hours. The conflicting results of McCollum and Simmonds,²⁰ and of Daniels and McClurg³⁵ on alkali of greater strength cannot at present be evaluated. For the proper solution of the question, food intake records must be considered.

While both water-soluble B and antineuritic vitamine do not seem to be destroyed by long exposure to a temperature of 100°C. or even slightly higher, the evidence is conflicting for temperatures of 120°C. Early investigations on the antineuritic vitamine in general substantiate the conclusion that 1 to 2 hours exposure to this temperature either totally destroys the antineuritic efficiency or markedly lowers it. The recent systematic investigation of Chick and Hume³⁶ indicates that the curative properties of wheat embryo and yeast extract are rapidly destroyed at 120°C. Wheat embryo, heated at 118–124°C. for 2 hours, failed to effect a complete cure of polyneuritis in pigeons when given in doses four times as large as the effective dose of unheated embryo. Heated at 110–117°C. for 40 minutes, it required more than twice as much embryo. Experiments with yeast extract showed a slower destruction of the antineuritic substance, since when heated at 120°C. for 2 hours 10 cc. of extract seemed to be as effective in curative action as 4 cc. of the unheated extract.

Unfortunately no strictly quantitative work on the effect of heat on water-soluble B, comparable to the investigations of Chick and Hume on the antineuritic vitamine, has been reported. McCollum and Davis³⁷ have shown that rats grow normally on

²⁹ Daniels, A. L., and McClurg, N. I., *J. Biol. Chem.*, 1919, xxxvii, 201.

³⁶ Chick, H., and Hume, E. M., *Proc. Roy. Soc. London, Series B*, 1917–19, xc, 60.

³⁷ McCollum, E. V., and Davis, M., *J. Biol. Chem.*, 1915, xxiii, 247.

rations containing 10 per cent of evaporated whey, heated in an autoclave at 15 pounds pressure (120°C.) for 1 hour, as the sole source of water-soluble B. In view of the low content of milk in this vitamine it does not seem probable that any appreciable destruction could have occurred in this experiment. In another experiment, 13.3 per cent of wheat embryo heated in the autoclave for 1 hour served as the sole source of water-soluble B, supporting normal growth and reproduction. McCollum, Simmonds, and Pitz³⁵ showed that rations containing as low as 25 per cent of navy beans, moistened, and heated in the autoclave for 75 minutes at 15 pounds pressure, supported normal growth and reproduction in rats. Daniels and McCurg³⁵ heated navy beans, soy beans, and cabbage in a pressure cooker for 15 to 40 minutes at 120°C. and found them to be suitable sources of water-soluble B in the ration of rats when included in excessive amounts. No definite conclusions can be deduced from this experiment, however, as to the rate of destruction of the vitamine if any destruction occurred. Drummond³² found that heating yeast dialysate for 30 minutes at 120°C. impaired its value as a source of water-soluble B, but the growth curves illustrating his experiment afford no basis for assuming any great destruction of vitamine, since only 6 per cent of the preparations tested was included in the rations as the sole source of water-soluble B.

The experiments just reviewed on the stabilities of the water-soluble growth-promoting vitamine and of the antineuritic vitamine, afford no sure basis of distinction though they are suggestive as indicating a greater stability of the former to hot alkali and to temperatures above 100°C.

In evaluating the data on the occurrence and properties of the two vitamins cited above, there seems to be very good reason for doubting their identity. In settling the question definitely, however, there is need of experiments in which different foods and preparations from foods are tested both for their growth-promoting properties and their curative effects on polyneuritic pigeons. Until such work is done in a quantitative way, dogmatic assertion that a lack of water-soluble B leads to polyneuritis or beri-beri, or an interchangeable use of the terms

³⁵ McCollum, E. V., Simmonds, N., and Pitz, W., *J. Biol. Chem.*, 1917, xxix, 521.

“water-soluble B” and “antineuritic vitamine” serves no purpose, tending rather to impede progress in this direction. It is significant that while many investigators in nutrition regard the etiology of beri-beri as definitely cleared up, the medical profession in those parts of the world where beri-beri is endemic are not at all convinced of the fact, and still believe that a definite infection is involved along with malnutrition.³⁹ Furthermore, Gibson and Concepcion¹⁶ say that in the Philippine Islands the therapeutic use of rice bran or extracts and preparations of rice bran has not given the specific results for man which were expected from theoretical considerations of the etiology of the disease, although the mortality has been greatly reduced. Williams and Johnston⁴⁰ also are veering away from the orthodox view of the cause of beri-beri in favor of a toxic view. They have been able to transmit polyneuritis to a pigeon, subsisting on unhusked rice, by feeding it the minced internal organs of birds that had died of the disease. This bird, 9 days after the ingestion of the diseased organs, developed all the typical symptoms of polyneuritis precisely as do birds fed on polished rice. The 2nd day thereafter the bird became completely prostrated, displayed increasingly severe retraction of the neck and labored breathing, and died. In view of such reports it cannot be doubted that many points in the etiology of polyneuritis and of beri-beri still need to be cleared up, and that premature deductions from a limited amount of experimental data do not hasten but can only defer the ultimate solution.

³⁹ See for example the discussion by medical men of the paper of Chick and Hume presented before the Society of Tropical Medicine and Hygiene (Chick, H., and Hume, E. M., *Tr. Soc. Trop. Med. and Hyg.*, 1916-17, x, 179-186).

⁴⁰ Williams, R. R., and Johnston, J. A., *Philippine J. Sc., Section B*, 1915, x, 337.

THE STRUCTURE OF YEAST NUCLEIC ACID.

IV. AMMONIA HYDROLYSIS.

BY P. A. LEVENE.

(From the Laboratories of The Rockefeller Institute for Medical Research.)

(Received for publication, November 1, 1919.)

The tetranucleotide theory of the structure of yeast nucleic acid was first enunciated by the writer¹ and was subsequently conclusively demonstrated by the experimental evidence furnished by Levene and Jacobs,² and by Levene and La Forge.³ The facts on which the theory was based were: first, the isolation of four nucleosides; second, the isolation of simple pyrimidine nucleotides. These were obtained on partial hydrolysis of yeast nucleic acid. The third fact, important for the development of the theory, was the elucidation of the order of linkage of the components of one simple mononucleotide.⁴

The experimental data obtained until that phase of work permitted no rational formulation of the mode of linkage between individual mononucleotides. Our original graphic representation of the entire molecule of yeast nucleic acid had only an arbitrary schematic sense. In a publication on thymus nucleic acid, Levene and Jacobs made that point clear. Owing to pressure of other work, our own investigations into the problem of the linkage of the mononucleotides was making slow progress, when Thannhauser with his collaborators,⁵ and Jones with his collaborators⁶ entered the field of nucleic acid study.

¹ Levene, P. A., *Biochem. Z.*, 1909, xvii, 121.

² Levene, P. A., and Jacobs, W. A., *Ber. chem. Ges.*, 1909, xlii, 2475, 2703; 1910, xliii, 3151; 1911, xliv, 1027.

³ Levene, P. A., and La Forge, F. B., *Ber. chem. Ges.*, 1912, xlv, 608, 3164.

⁴ Levene, P. A., and Jacobs, W. A., *Ber. chem. Ges.*, 1908, xli, 2704; 1909, xlii, 335, 1198.

⁵ Thannhauser, S. J., *Z. physiol. Chem.*, 1914, xci, 329. Thannhauser, S. J., and Dorfmueller, G., *ibid.*, 1917, c, 121.

⁶ Jones, W., and Richards, A. E., *J. Biol. Chem.*, 1914, xvii, 71. Jones, W., and Germann, H. C., *ibid.*, 1916, xxv, 93. Jones, W., and Read, B. E., *ibid.*, 1917, xxix, 123; xxxi, 39.

By means of either enzyme action or by methods of chemical hydrolysis, they obtained intermediate substances which were regarded by them as di- and trinucleotides.

The methods of hydrolysis employed by them in some instances were identical with those employed by us in other instances, slightly modified. The method of separating simple nucleotides as their brucine salts was also introduced by us.

Thannhauser first announced the isolation of a trinucleotide from the products of digestion of nucleic acid by enzymes. Later, Thannhauser and Dorfmueller hydrolyzed nucleic acid by means of 25 per cent ammonia and supposedly cleaved the molecule into uridinphosphoric acid and a trinucleotide containing the remaining three nucleotides. On acid hydrolysis with 2 per cent sulfuric acid these authors obtained only uridinphosphoric acid. This publication appeared in Germany in 1917 and did not reach us until 1919. In 1914, Jones and Richards described experiments by which they thought they had cleaved nucleic acid into two dinucleotides; guanin-cytosine, and adenin-uridin dinucleotides. Subsequently, Jones and his coworkers described the same two dinucleotides which they obtained on hydrolysis of yeast nucleic acid by heating the acid in an autoclave in a 2.5 per cent ammoniacal solution for $1\frac{1}{2}$ hours at a temperature of 115°C . On the other hand, on hydrolysis by means of dilute acids, Jones and Read described a cytidin-uracil dinucleotide. On the basis of their respective findings, Jones and Thannhauser presented theories of the mode of linkage between the nucleotides.

According to Jones the structure of yeast nucleic acid is as follows:

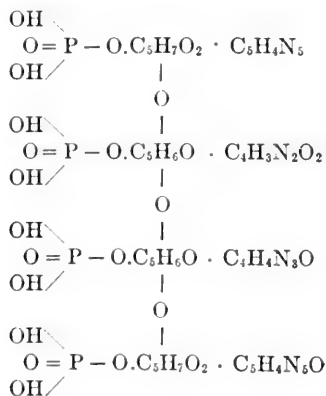

Thannhauser, on the other hand, presents the linkage of the nucleotides in the following way:⁷

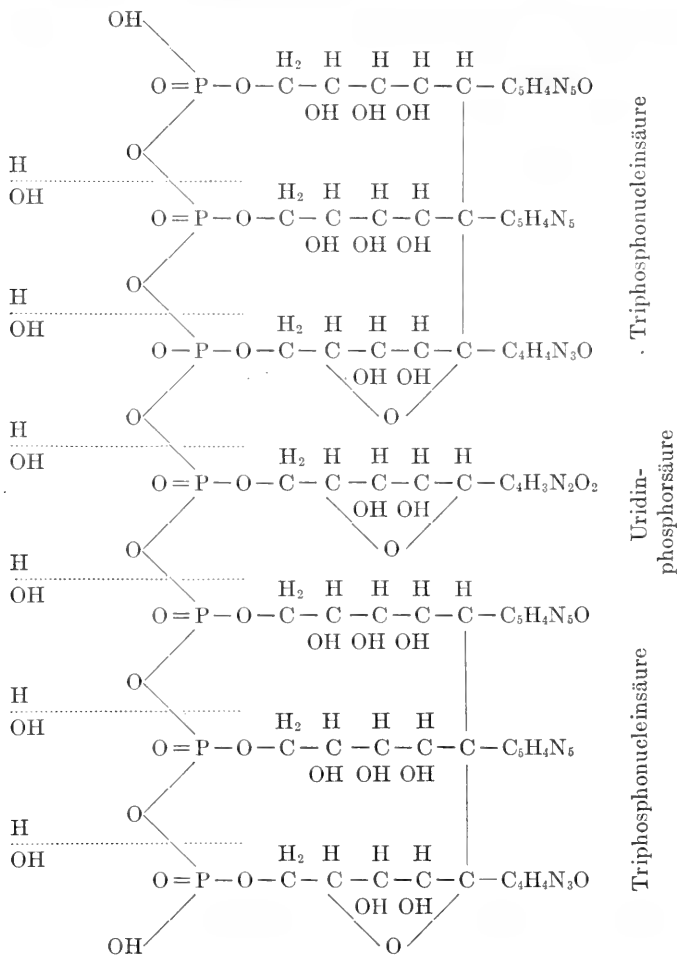

⁷ In Thannhauser's representation there is an oversight in regard to the cytidin linking.

It is given

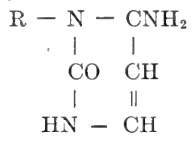

It should be

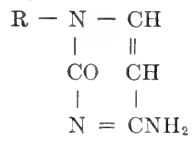

These theories are based on the following considerations:

That of Jones on the assumption of the reality of the dinucleotides, and on the observations that the so called dinucleotides are tetra-basic. The theory of Thannhauser is based on the assumption of the belief in the reality of the trinucleotide, and second, on the fact that the so called trinucleotide is hexo-basic.

In previous communications we have criticized the conclusions of these writers, on the assumption that their observations were correct.⁸ In a later communication,⁹ we have shown that the cytidin-uridin dinucleotide was a mixture of uridin and cytidin mononucleotides. Uridinphosphoric acid was obtained as a crystalline barium salt. It may be mentioned here that optical rotation of the crystalline salt air-dry was $[\alpha]_D^{20} = 3.5$, or dry and barium-free $[\alpha]_D^{20} = 5.83$, whereas Thannhauser and Dorfmueller found for their uridinphosphoric acid + 14.4.

On the other hand the barium salt of the cytidinphosphoric acid had the optical rotation of $[\alpha]_D^{20} = + 14.0$ or barium-free and dry $[\alpha]_D^{20} = + 23.3$ which agrees with the recent finding of Thannhauser for the crystalline cytidinphosphoric acid, which was $[\alpha]_D^{20} = 23$. Thus it is possible that the substance described by Thannhauser as uridinphosphoric acid was of a lesser degree of purity than that of the cytidinphosphoric acid.

In a still later publication¹⁰ we reported on the finding that the so called cytidin-uridin dinucleotide was fractionated by us into uridinphosphoric and adenosinphosphoric acids. The former was identified as the crystalline barium salt, the latter as the brucine salt, which at the time of that publication was converted into the barium salt. Since from a large quantity of brucine salt there was obtained only a small quantity of a barium salt analyzing satisfactorily for the salt of the adenosin nucleotide, the publication of the analytical data on that nucleotide was delayed. It was subsequently found that adenosinphosphoric acid is identified most conveniently as the free acid. Crystalline adenosinphosphoric acid was described by Jones and Kennedy;¹¹ the substance obtained by us differed from that of

⁸ Levene, P. A., *J. Biol. Chem.*, 1917, xxxi, 591.

⁹ Levene, P. A., *Proc. Soc. Exp. Biol. and Med.*, 1917, xv, 21.

¹⁰ Levene, P. A., *J. Biol. Chem.*, 1918, xxxiii, 425.

¹¹ Jones, W., and Kennedy, R. P., *J. Pharmacol. and Exp. Therap.*, 1919, xiii, 45.

Jones only in the fact that our material dried in air contained no crystal water, whereas the substance of Jones contained one crystal water. The optical rotation of our substance is $[\alpha]_D^{20} = -38.5$. Whereas the rotation of adenosinphosphoric acid remains constant either in water or in 5 per cent ammonia water, the rotation of guanosinphosphoric acid shows a marked increase in its levorotation in ammonia water. This point may serve for differentiation between the two nucleotides. Thus it is proven that the adenin-uridin dinucleotide is a mixture of two mononucleotides.

The fraction which was originally regarded by Jones as a guanin-cytosine dinucleotide, and from which Read isolated an amorphous guanylic acid, was also found by us to consist principally of guanosinphosphoric acid. In addition a small proportion of uridinphosphoric acid was found in this fraction. The presence of the latter nucleotide might have escaped isolation if not for its recently described property of forming a crystalline lead salt.

The guanylic acid was isolated in a crystalline form, and constituted the greater part of the fraction.

The method of hydrolysis employed by us consisted in heating the nucleic acid in a 2.5 per cent aqueous ammonia solution for 1 hour at 100°C. Thus the treatment was milder than the one employed by either Jones or Thannhauser. Thus the present findings nullify the experimental evidence in support of the theories of Jones and of Thannhauser. From the theoretical point of view, the theory of Thannhauser is not very tenable for the reason that a carbon to carbon-linking implies a very strong union, whereas the polynucleotide is readily dismembered into mononucleotides. Thannhauser, in fact, accepts it himself with great reserve. As regards the ether-linking accepted by Jones, it must be remarked that, as a rule, an ether-linking represents a very firm union. If one accepts that this rule does not apply to carbohydrates linked in ether form, he should present experimental evidence in support of this view.

However, if the work of Jones and of Thannhauser failed to support their speculations regarding the mode of linkage of the mononucleotides, it has been of great importance in furnishing further proof of the nucleotide structure of yeast nucleic acid;

and also, in making it possible to show that the molecule of nucleic acid is readily decomposed into mononucleotides, and that the linkage between all nucleotides is of the same order.

On the basis of considerations such as these the linkage of the nucleotides could be expressed most simply in the following way:

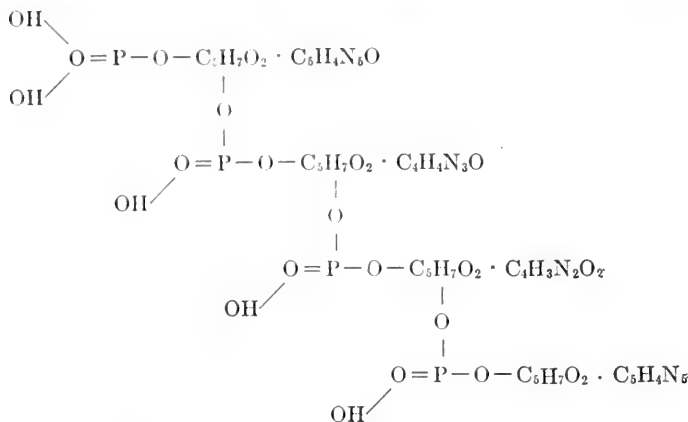

For the present this form expresses the facts known about the structure of yeast nucleic acid. New facts and new evidence may cause its alteration, but there is no doubt as to the polynucleotide structure of the yeast nucleic acid.

It is unfortunate that, owing to war conditions, the work of Thannhauser was not known to us earlier, also that apparently our work was not known to Thannhauser.

EXPERIMENTAL.

The mode of hydrolysis was practically the same as that described in a previous communication,¹⁰ with a difference in one detail; namely, the temperature of the autoclave was maintained at 100°C.

Treatment of the product of hydrolysis was also the same as described in that communication, and essentially the same as employed by Jones and his collaborators. The fraction precipitated by 98 per cent alcohol will be referred to as guanin fraction, and that remaining in solution as adenin fraction.

Adenin fraction was treated in exactly the same manner as that described in the previous communication. The brucine salt was recrystallized nine times with boiling 35 per cent alcohol.

The crystalline deposit consisted of uridinphosphoric acid previously described. The first three mother liquors, on concentration, gave a brucine salt containing C = 53.00, H = 6.40, and N = 10 per cent. The subsequent six mother liquors, on concentration, gave a brucine salt containing N = 8.5 per cent.

The brucine salt of the first three mother liquors was transferred into the ammonium salt. Originally the ammonium salts were converted into the barium salt. Barium salts, having analytical value sufficiently approaching that required by the theory, were obtained only after many purifications which were associated with much loss. Finally, an attempt was made to transform the ammonium salt into the free nucleotide. This was accomplished without difficulty in the following manner. To the hot solution of the ammonium salt, while the mixture was agitated, a hot solution of neutral lead acetate was added in a slow stream. When the necessary volume of lead acetate (25 per cent solution) was added, the mixture was brought to a boil and filtered. The precipitate was washed in a mortar and filtered; the operation was repeated three times. Finally the precipitate was suspended in water, treated with hydrogen sulfide, and the filtrate from lead sulfide was concentrated under diminished pressure at room temperature. On standing, adenosinphosphoric acid crystallized in long needles resembling the free nucleoside. The substance differed from that described by Jones in that it crystallized without crystal water. The analysis of the air-dry substance was as follows:

0.1010 gm. of the substance gave 0.1268 gm. of CO_2 and 0.0368 gm. of H_2O .

0.1000 gm. of the substance employed for Kjeldahl nitrogen estimation required for neutralization 14.26 cc. of 0.1 N acid.

0.3000 gm. of the substance gave 0.0940 gm. of $\text{Mg}_2\text{P}_2\text{O}_7$.

	Calculated for $\text{C}_{10}\text{H}_{14}\text{N}_6\text{P}_7\text{O}_7$. per cent	Found. per cent
C.....	34.57	34.24
H.....	4.07	4.08
N.....	20.17	19.96
P.....	8.94	8.73

The optical rotation of the substance in aqueous solution was

$$[\alpha]_D^{20} = \frac{-0.77 \times 100}{1 \times 2} = -38.5$$

In a solution of 5 per cent ammonia water the rotation was

$$[\alpha]_D^{20} = \frac{-0.80 \times 100}{1 \times 2} = -40.0$$

Hydrolysis of the Adenosinphosphoric Acid.—2 gm. of the substance in 35 cc. of 1 per cent sulfuric acid were boiled over flame with reflux condenser for 1 hour. The product of hydrolysis was neutralized with sodium hydroxide and to the neutral solution aqueous picric acid was added as long as a precipitate formed. The precipitate was dissolved in hot water and allowed to crystallize.

The analysis of the air-dry substance was as follows:

0.1000 gm. of the substance gave 26.2 cc. of nitrogen gas at $T^\circ = 26^\circ\text{C}$. and $P = 752$ mm.

	Calculated for $\text{C}_5\text{H}_8\text{N}_6\text{C}_2\text{H}_2(\text{OH})(\text{NO}_2)_2 + \text{H}_2\text{O}$.	Found.
	per cent	per cent
N.....	29.32	29.60

The substance decomposed at 177°C . (uncorrected).

Brucine Salt of Adenosinphosphoric Acid.—2 gm. of the nucleotide were dissolved in hot water and the solution was neutralized with a solution of brucine in methyl alcohol. On cooling, the solution nearly solidified. The crystals of the brucine salt of the nucleotide were filtered off with suction, and the substance was recrystallized three times out of 35 per cent alcohol.

The air-dry substance on heating in a sealed capillary tube melted as follows: At 177°C . it began slightly to contract; at 195° , the substance effervesced, remaining perfectly colorless; at 225° a second point of effervescence was observed, the substance turning dark. The substance analyzed as follows:

0.1020 gm. of the substance gave 0.1978 gm. of CO_2 and 0.0572 gm. of H_2O .

0.2000 gm. of the substance gave 17.6 cc. of nitrogen gas at $T^\circ = 24^\circ\text{C}$., $P = 769$ mm.

0.3000 gm. of the substance gave 0.0244 gm. of $\text{Mg}_2\text{P}_2\text{O}_7$.

	Calculated for $C_{10}H_{14}N_5PO_7 \cdot (C_{23}H_{26}O_4N_2)_2 \cdot 7H_2O$.	Found.
	per cent	per cent
C.....	53.28	52.88
H.....	6.40	6.28
N.....	10.00	10.23
P.....	2.47	2.27

The rotation of the substance was

$$[\alpha]_D^{20} = \frac{-0.74 \times 100}{1 \times 2} = -37.0$$

The *guanin fraction* consisted principally of guanosinphosphoric acid (guanylic acid). It was treated in a general way in the manner indicated by Read. The lead salts were converted into the brucine salts, and these were fractionated in the same manner as the salts of the adenin fraction. However, the substance obtained from all the nine mother liquors contained over 10 per cent of nitrogen and only the fraction constituting the ultimate crystalline deposit contained on analysis about 8.75 per cent of nitrogen. Surprisingly also this fraction consisted in the main of guanylic acid. The brucine salts were converted into the ammonium salts. These were dissolved in boiling water and to the hot solution a hot solution of lead acetate was added in a slow stream. The mixture was then brought to a boil and filtered hot. The lead precipitate was freed from lead and concentrated under diminished pressure at room temperature. Generally an amorphous, somewhat gelatinous precipitate settles out. In some instances the solution turns into a semiliquid jelly. To bring about final crystallization, no general rule can be given. At times repeated precipitation with lead acetate will lead to a filtrate which, on concentration, solidifies into a crystalline mass. Often it is advisable to precipitate the nucleotide by means of lead acetate fractionally. The later fractions as a rule crystallize with less difficulty.

The properties and analysis of the crystalline guanylic acid were described in a previous communication.¹²

When the brucine salts with 8.75 per cent of nitrogen were converted into ammonium salts, and when these were taken up

¹²Levene, P. A., *J. Biol. Chem.*, 1919, xl, 171.

in hot water, part of the substance remained insoluble. This residue consisted of brucine salt which escaped, being converted into ammonium salt. The brucine salt on analysis showed a nitrogen content of $N = 7.8$ per cent. This brucine salt was then converted into the ammonium salt. The latter was dissolved in boiling water, and a hot solution of neutral lead acetate was added. The mixture was brought to a boil and filtered hot. The filtrate was seeded with a few crystals of the lead salt of uridinphosphoric acid, and allowed to stand near a hot water bath. It was found that when the cooling of the filtrate proceeded rapidly a gelatinous lead salt settled out. If, however, the cooling was progressing slowly the lead salt of uridinphosphoric acid settled out in crystalline form. For analysis the substance was dried to constant weight under diminished pressure at the temperature of xylene vapor. It analyzed as follows:

0.1118 gm. of the substance gave 0.0856 gm. of CO_2 and 0.0218 gm. of H_2O .

0.1848 gm. of the substance employed for Kjeldahl nitrogen estimation required for neutralization 7.7 cc. of 0.1 N acid.

0.2772 gm. of the substance gave 0.0574 gm. of $Mg_2P_2O_7$.

	Calculated for $C_9H_{11}N_2PO_7Pb$. <i>per cent</i>	Found. <i>per cent</i>
C.....	20.40	20.73
H.....	2.10	2.18
N.....	5.29	5.84
P.....	5.86	5.78

THE ACTIVITY OF LUNG EXTRACT, AS COMPARED TO EXTRACTS OF OTHER TISSUES, IN INDUCING COAGULATION OF THE BLOOD.

By C. A. MILLS.

(From the Department of Biochemistry, University of Cincinnati, Cincinnati.)

(Received for publication, October 14, 1919.)

Wherry and Ervin (1), in experimenting with the intravenous injection of extracts of tuberculous lung tissue, found that very small doses of an extract of normal as well as tuberculous lung tissue would produce death in a few seconds in rabbits and guinea pigs. It was at their request that I undertook to discover the cause of the sudden death in these cases.

The extracts were made by grinding the fresh lung tissue well with sand in a mortar, adding gradually while stirring 10 cc. of 0.9 per cent NaCl for each gm. of tissue taken. The mixture was then centrifuged for 20 to 30 minutes at about 3,000 revolutions per minute and the slightly cloudy, reddish solution used for the injections. It was found by trial that 0.3 cc. of this solution injected *rapidly* into the ear vein of a rabbit weighing 1,000 to 1,500 gm. caused respiratory symptoms of irregular breathing and uneasiness in 20 to 30 seconds, weakness and prostration shortly afterwards, and death with convulsions and respiratory spasms usually within 1 minute after the injection. If a larger dose, such as 0.5 cc., was injected rapidly into a rabbit of this size respiratory symptoms began in 20 seconds and death, accompanied by violent convulsions and spasms, followed within 10 seconds. For rabbits of 1,800 to 2,500 gm. the dose necessary to produce death was 0.4 cc. so that the reaction is in a measure quantitative.

On examination of the rabbits immediately after cessation of the spasms, the heart was usually found beating rhythmically, although there were sometimes arrhythmias and fibrillation. All organs appeared normal, the lungs always being found collapsed

after opening the thorax. On opening the heart or vessels, larger or smaller clots were always found and sometimes the whole blood was found to be coagulated, especially if more than the minimum fatal dose was given. In cases where the whole blood was not clotted, the escaping fluid portion clotted more slowly than normal, the length of time before the occurrence of spontaneous clotting varying from a few minutes to a day.

These observations lead to the conclusion that in these cases death was due in a large measure at least to intravascular clotting, the symptoms probably resulting from the complete asphyxia of the nervous system. Although the death resembled that of anaphylaxis, yet in contradistinction to the latter the lungs were always found to collapse on opening the thorax, whereas in deaths from anaphylaxis the lungs do not collapse.

I therefore undertook the study of the particular power of lung tissue in causing thrombosis, as I was unable to find any reference to the peculiar toxicity of lung extracts in this respect. This study has resulted in showing the very remarkable thromboplastic power of the lungs, a power far surpassing that of any other tissue of the body.

Intravascular coagulation from the intravenous injection of tissue extracts has been known to be possible for many years. Quoting from Carpenter (2),

"The contact of dead animal matter with the blood appears to promote the coagulation of its fibrin in a very remarkable degree; occasioning coagula to form, whilst it is yet actively moving in the vessels of the living body. Thus M. Dupuy found that the injection of cerebral substance into the veins of an animal occasioned its death almost as instantaneously as if prussic acid had been administered; the circulation being rapidly brought to a stand, by the formation of voluminous clots in the heart and large vessels. These experiments were repeated and confirmed by M. de Blainville. (Gazette Medicale, 1834, p. 521.) The same effect is produced with still more potency, when the substance injected is rather undergoing degradation, than actually dead; for it then seems to act somewhat after the manner of a ferment, producing a marked diminution in the vitality of the solids and fluids with which it may be brought in contact. Such is pre-eminently the case with *pus*, as was long ago observed by Hunter and as Mr. H. Lee has since determined more precisely. It was found by the latter, that healthy blood received into a cup containing some offensive *pus* coagulated in *two* minutes; whilst another sample of the same blood, received into a clean vessel of similar size and shape, required *fifteen* minutes for its complete coagulation."

Wooldridge (3), working from 1881 to 1889, was the first, however, to attempt to isolate the active thromboplastic material from the tissue extracts and to make a thorough study of the action of such extracts. He used extracts prepared from testes, thymus, and lymph glands, extracting the fresh tissues with water and precipitating the active material from the solution by making it strongly acid with acetic acid. The precipitate was then washed in water and dissolved in very dilute carbonate solution. Such solutions he found to produce thrombosis throughout the whole vascular system of rabbits after rapid intravenous injections, but in dogs, clots were usually found only in the portal system. In any case, if the animal survived the thrombosis, a second injection within 24 hours was without effect, and blood drawn after such injection had a greatly diminished coagulability, spontaneous coagulation often being delayed as long as 24 hours. The remarkable fact was discovered that the addition of more of the tissue extract to this blood outside the body produced coagulation in a few minutes. He observed that the degree of non-coagulability of the blood was in a measure proportional to the extent of the thrombosis.

In studying the extracts to determine the active substance, he decided that a protein-phospholipin compound was responsible for the results. This compound could be extracted from the acetic acid precipitate with dilute alkali. He states that the solution was not a true solution since the dissolved substance would not pass through a clay cell. If he extracted this precipitate with alcohol and ether the activity of the undissolved residue was lost, so that the phospholipin must be a necessary part of the compound. Also on digestion of the solution with pepsin and hydrochloric acid, the phospholipin, with a small amount of the protein, was precipitated, and the remaining solution had lost its activity. The precipitate was active. Examination of the phospholipin convinced him it was a lecithin-like substance, although purified lecithin from egg yolk was not active. Lecithin prepared from other tissues gave him the same results as the tissue extracts. Wooldridge was not familiar with cephalin at that time, so that he did not identify the active phospholipins as cephalin which was present as an impurity in his tissue lecithin, although he did show that not all lecithin prepa-

rations were active. More recent work in Howell's laboratory (4) indicated that the phospholipin inducing coagulation discovered by Wooldridge is cephalin, but the strange fact appeared from my experiments that although the nervous tissue is the tissue believed to be the richest in cephalin, yet extracts of the brain made in the same way as these lung extracts did not cause intravascular coagulation and death in rabbits in doses up to 3 cc. for an 1,800 gm. rabbit. It was therefore deemed advisable to compare as quantitatively as possible the thromboplastic activity of lung tissue extracts with that of extracts of other tissues of the body.

Fresh tissues of dogs killed in ether anesthesia and rabbits were used in making extracts similar to the lung extract described above, that is, for every gm. of the fresh tissue, after grinding thoroughly with sand, 10 cc. of 0.9 per cent NaCl solution were added, mixed well, and centrifuged to remove all solid particles. Extracts thus made were found to undergo a gradual loss of their power to induce coagulation when injected into the circulation or of hastening coagulation when added to blood outside the body. When standing at 5°C. very little change occurred in the first few days, but activity had almost disappeared at the end of 3 weeks. This loss of activity was not due to a settling out of the active matter formerly in suspension, since on shaking and injecting, or adding precipitate and solution mixed, the diminution of activity persisted. It might be, however, that a gradual agglomeration of particles had occurred leading to a smaller number of larger aggregates with a resulting diminution of surface and hence of activity. This rather than a chemical change might explain the progressive loss of power. This possibility will be further investigated.

The activity of the tissue extracts prepared as described were tested in two ways, (1) by injections into the blood stream of dogs and rabbits, and (2) by testing their power of hastening coagulation when added to peptone and oxalate plasma outside the body. In the latter case the test-tube method for determining the coagulation time was used, coagulation being considered complete when the tube could be inverted without spilling the contents. If care was taken in shaking the tubes and in keeping all other factors constant, this method was considered sufficiently accurate for this work.

Peptone plasma and oxalated plasma of dog's blood were used in most of the tests, although two sets of rabbit tissue extracts were tested on rabbit blood rendered partially non-coagulable by a process which will be described in another paper.

In order to compare the activity of the extracts of the different tissues, one method was to find the amount of the various extracts necessary to induce coagulation of 1 cc. of peptone plasma in the same time as a definite amount of lung extract. Another method used was to add the same amount of the different extracts to oxalate plasma and compare the amount of acceleration of coagulation of the plasma by serum. All tests were carried out in a water bath at 38–40°C.

Tables I and II indicate the results of the tests carried out with the extracts of the tissues of two different dogs.

The pancreas, skeletal muscle, thyroid, and omentum contained so little of the thromboplastic material that they would not accelerate the coagulation to 30 seconds in any amount, so the figures for them are approximations derived from the degree of lessening of coagulation time by increasing amounts of the extracts.

TABLE I.

Tissue extract used (dog).	Time of coagulation of 1 cc. of oxalate dog plasma, by 3 drops of extract and 6 drops of serum.*	
	Tissues of Dog I.	Tissues of Dog II.
	<i>min.</i>	<i>min.</i>
Lung.....	$\frac{1}{2}$	$\frac{1}{2}$
Kidney.....	4	4
Testes.....	7	6
Brain.....	8 $\frac{1}{2}$	6
Heart.....	8	7
Spleen.....	9	4
Bone marrow.....	7	7
Adrenal.....	8	8 $\frac{1}{2}$
Liver.....	11	8
Omentum.....	9	16
Skeletal muscle.....	14	12
Pancreas.....	14	14
Thyroid.....	14	15

* 1 cc. of oxalate plasma and 6 drops of serum (with no extract) showed no coagulation in 1 $\frac{1}{2}$ hours, but were coagulated in 24 hours.

Activity of Lung Extract

TABLE II.

Tissue extract used (dog).	Amount of extract necessary to coagulate 1 cc. of peptone dog plasma in 30 seconds.	
	Tissues of Dog I.	Tissues of Dog II.
	<i>gtt.</i>	<i>gtt.</i>
Lung.....	2	2
Kidney.....	5	5
Testes.....	8	15
Brain.....	7	6
Heart.....	20	12
Spleen.....	4	4
Bone marrow.....	20	20
Adrenal.....	6	20
Liver.....	25	20
Omentum.....	30 +	30 +
Skeletal muscle.....	30 +	30 +
Pancreas.....	40 +	30 +
Thyroid.....	30 +	20 +

The activity of extracts of the tissues of two rabbits on partially non-coagulable rabbit blood is shown in Table III.

TABLE III.

Tissue extract used (rabbit).	Amount of extract necessary to clot 1 cc. of rabbit blood.	
	90 seconds. Tissues of Rabbit I.	70 seconds. Tissues of Rabbit II.
	<i>gtt.</i>	<i>gtt.</i>
Lung.....	1	1
Kidney.....	5	5
Heart.....	5	5
Thymus.....		3
Spleen.....	8	4
Brain.....	8	13
Skin.....		10
Testes.....		20 +
Ovary.....	22	
Uterus.....	20	
Liver.....	30 +	30
Bone marrow.....		20 +
Pancreas.....		20 +
Adrenal.....	26 +	20 +
Omentum.....	30	
Skeletal muscle.....	30 +	30 +

Here again some of the tissues were so poor in the active substance that they would not clot the blood in the specified time in any amount, so that the figures given are only approximations.

In every case studied the lung extract was found to be much stronger than that from any other tissue, being from two to thirty times as strong as the other tissues in accelerating coagulation. Kidney, heart, brain, spleen, thymus, and skin come next in activity, somewhat in the order named. Then, certain other tissues, pancreas, skeletal muscle, liver, bone marrow, omentum, and adrenal, showed only slight thromboplastic activity as compared to the lung tissue.

Having thus established the predominant thromboplastic power of the lung extracts I next attempted to discover whether the toxicity from intravenous injections of these extracts paralleled their thromboplastic activity. To this end injections were made into rats and rabbits. In using rats the injections were made directly into the heart, but with rabbits injections were into an ear vein. Adult white rats, weighing about 350 gm., were used. They were found to be much less affected by partial coagulation of the blood in the vessels than rabbits, quick death being produced only by almost solid intravascular coagulation following injections of relatively large doses of the extracts. Most of the extracts of rabbits and rat tissues would not produce coagulation in rats in doses up to 3 cc. when made up in the usual way, so double strengths of these extracts were used, that is, only half the usual amount of saline solution was used for each gm. of fresh tissue. These extracts were labeled ($\times 2$). Table IV indicates the dosages of the various extracts necessary to produce rather extensive coagulation in the vessels of the rats.

In intravenous injections into rabbits only two of the tissue extracts proved fatal, death occurring in rabbits after only slight thrombosis. Lung extract was fatal in doses of 0.3 to 0.4 cc. and kidney extract ($\times 2$) was fatal in a dose of 2.0 cc. producing only a slight amount of thrombosis, and with death occurring after a delay of $2\frac{1}{2}$ minutes. None of the other tissue extracts was fatal in doses up to 3.0 cc. Wooldridge reports solid thrombosis of the whole system in rabbits with injections of thymus, testes, and lymph gland extracts, but he used many times the amount of material for injections that was used in these cases.

Thus he used $\frac{1}{2}$ to 1 gm. of the washed acetic acid precipitate from the extracts to obtain such solid intravascular coagulations.

From these intravenous injections into rats and rabbits as described above, it is evident that the extracts are toxic in much the same order as they exhibit thromboplastic activity in extravascular coagulation, lung extract being much the most active of all tissue extracts in each case.

Most hemostatic preparations on the market today are prepared from brain material, but from the results of the above experiments it would seem that lung tissue would afford a much stronger hemostatic. Battelli (5) describes a method for preparing such material from fresh horse or sheep lungs.

TABLE IV.

Extract used.	Coagulative dosage for rats.
	cc.
Rat lung extract.....	0.5
“ kidney “	1.0
“ “ “ (×2).....	0.9
“ brain “ (×2).....	1.1
Rabbit lung extract.....	0.4
“ kidney “ (×2).....	0.9
“ brain “	3.0
“ “ “ (×2).....	1.0
“ heart “ (×2).....	1.5
“ liver “ (×2).....	2.0

The significance of such a strong thromboplastic activity in lung tissue, and not so very much less in kidney tissue, is an interesting question. Is it a protective mechanism against possible hemorrhages in these organs in which the rich capillary network is covered only by a one celled layer of epithelium? This high activity of the lung tissue may perhaps have an especial function in certain diseases, such as pneumonia, where there occurs such an extensive destruction of lung tissue. With the extremely rich blood supply in all parts of the lungs one would expect severe hemorrhages in these cases, but the hemorrhages are, in fact, not one of the main characteristics of this disease. May it not be the liberation of this active material by the tissue destruction which protects against extensive hemorrhages? The

one extract of the skin tested was also found to possess considerable thromboplastic activity, again denoting a possible protective mechanism.

The investigation of the nature of the active principle in lung extract is being carried further and will form the subject of another paper.

SUMMARY.

1. Sudden death from the intravenous injection of lung tissue extract is apparently due to intravascular coagulation, although there is a possibility of anaphylactic effect on the lungs, not sufficient, however, to keep them from collapsing on opening the thorax.

2. Tissue extracts were tested as to their thromboplastic activity on the blood both intra- and extravascularly. Lung extracts were found far more active than the extracts of any other tissue, kidney coming second, and then heart, brain, spleen, thymus, testes, skin, somewhat in the order named. The remaining tissues were weakly active as compared to lung, some of them showing very slight thromboplastic action.

3. Lung tissue offers a possible source for the preparation of a strong hemostatic.

4. The strong coagulative activity of lung and kidney tissues, and to a lesser degree of skin, is suggestive of a possible protective mechanism against hemorrhage.

BIBLIOGRAPHY.

1. Wherry, W. B., and Ervin, D. M., *J. Infect. Dis.*, 1918, xxiii, 240.
2. Carpenter, W. B., *Carpenter's principles of human physiology*, London, 1869, 239.
3. Wooldridge, L. C., *On the chemistry of the blood, and other scientific papers*, London, 1893, Croonian lecture on the coagulation of the blood.
4. Howell, W. H., *Am. J. Physiol.*, 1912-13, xxxi, 1.
5. Battelli, F., *Compt. rend. Soc. biol.*, 1910, lxxviii, 789; abstracted in *Chem. Abstr.*, 1910, iv, 2513.

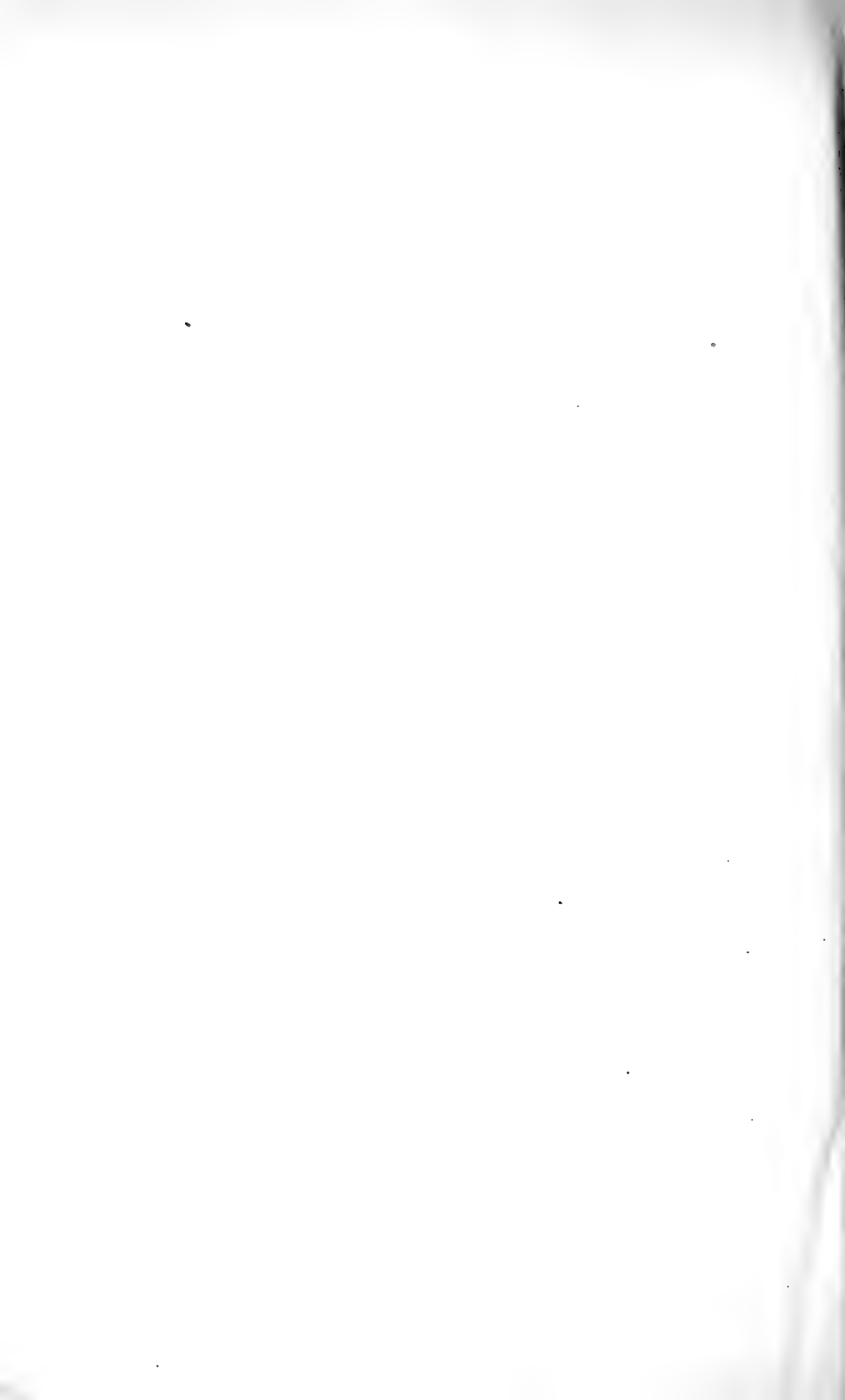

THE HYDROLYSIS OF STIZOLOBIN, THE GLOBULIN OF THE CHINESE VELVET BEAN, STIZOLOBIUM NIVEUM.

BY D. BREESE JONES AND CARL O. JOHNS.

(From the Protein Investigation Laboratory, Bureau of Chemistry, Department of Agriculture, Washington.)

(Received for publication, October 28, 1919.)

The preparation of the globulin used for this hydrolysis is described in a previous publication from this laboratory (1).

The hydrolysis and the determination of the resulting amino-acids were carried out, for the greater part, in the usual manner, with a few exceptions which will be noted later.

A slight modification of the customary method of drying the ether solutions of the esters with anhydrous sodium sulfate was made. It seems very probable that during the extraction of the esters with ether, after their liberation with sodium ethylate, or with sodium hydroxide, as is sometimes necessary after the second esterification, some of the alkali passes into the ether, and later decomposes to some extent the easily hydrolyzed esters. Accordingly, finely powdered ammonium chloride was mixed with the sodium sulfate used for drying the ether solution of the esters. Any caustic alkali present would thus be removed by the action of ammonium chloride, with the formation of sodium chloride and ammonia, and in this way the hydrolysis of the esters reduced to a minimum.

The method of Levene and Van Slyke (2) for the separation of alanine from valine by means of phosphotungstic acid was used with good results.

The percentages of basic amino-acids in stizolobin, as determined by the Van Slyke method, have already been published (1).

The percentages of the various amino-acids obtained by the hydrolysis of stizolobin are summarized in Table I. For the sake of comparison, the percentages of amino-acids found in phaseolin,

the globulin of the white navy bean, *Phaseolus vulgaris*, are also given.

As is seen, the summation of the hydrolysis of stizolobin, although comparatively high, falls far short of accounting for the theoretical amount of hydrolysis products which should result. Some time ago we became convinced that with the methods now in use one cannot hope to account quantitatively for nearly all

TABLE I.
Percentage of Amino-Acids in Stizolobin and Phaseolin.

	Stizolobin.	Phaseolin.*
	<i>per cent</i>	<i>per cent</i>
Glycine.....	1.66	0.6
Alanine.....	2.41	1.8
Valine.....	2.88	1.0
Leucine.....	9.02	9.7
Proline.....	4.00	2.8
Phenylalanine.....	3.10	3.3
Aspartic acid.....	9.23	5.3
Glutamic acid.....	14.59	14.6
Hydroxyglutamic acid.....	2.81	
Serine.....	0.67	0.4
Tyrosine.....	6.24†	2.2
Cystine.....	1.13	
Arginine.....	7.14	4.9
Histidine.....	2.27	2.0
Lysine.....	8.51	4.0
Tryptophane.....	Present.	
Ammonia.....	1.55	2.1
Total.....	77.21	54.7

* Osborne, T. B., and Clapp, S. II., *Am. J. Physiol.*, 1907, xviii, 295.

† By the colorimetric method of Folin and Denis.

the products which proteins yield on hydrolysis, but that methods must be developed whereby the products of hydrolysis can be separated more directly than by esterifying the amino-acids and distilling the esters as originally worked out by Fischer. As is well known, it is rarely if ever a 100 per cent esterification of a pure organic acid can be accomplished, and when one considers the complex mixture which results from the hydrolysis of a protein, consisting of eighteen or more amino-acids, humin, and other

secondary decomposition products, a high percentage esterification can hardly be expected. The hope of attaining anywhere near a theoretically complete summation is therefore practically excluded from the beginning. We have been working for some time on the direct determination of the amino-acids in another protein by methods which do not involve the process of esterification and distillation of esters. This work is still in progress.

A method for the determination of proline without involving the esterification of the amino-acids is described. The products of hydrolysis of the protein, after having first removed the bases and mineral acids, are obtained in a dry powdered form, from which the proline is extracted with boiling absolute alcohol. The non-amino nitrogen in the solution is determined and the per cent of proline calculated. Several determinations made in this way gave results closely agreeing with each other, and also with the percentage obtained from the esters.

Since the work on this hydrolysis was completed an article published by Dakin (3) appeared in which he describes a method for the partial separation of the amino-acids in a hydrolysis mixture by extracting the aqueous solution of amino-acids with butyl alcohol, and in which is also described for the first time the isolation and properties of the new amino-acid, hydroxyglutaminic acid. By means of this method, Dakin states that the products of hydrolysis of a protein may be readily separated almost completely into the following five groups:

(1) Monoamino-acids, both aliphatic and aromatic, insoluble in alcohol but extracted by butyl alcohol.

(2) Proline, soluble in alcohol and extracted by butyl alcohol.

(3) Peptide anhydrides (diketopiperazines), extracted by butyl alcohol but separated from (2) by sparing solubility in alcohol or water.

(4) Dicarboxylic acids, not extracted by butyl alcohol.

(5) Diamino-acids, not extracted by butyl alcohol but separable from (4) by phosphotungstic acid and other means.

In order to check up by this method the results we had already obtained for aspartic and glutaminic acids in stizolobin by the ester method, as well as to look for hydroxyglutaminic acid, some of the residues of amino-acids remaining from the direct determination of proline were examined by this method for

aspartic, glutaminic, and hydroxyglutaminic acids. 2.81 per cent of hydroxyglutaminic acid was obtained in the form of the difficultly soluble silver salt.

One of the most striking results of this examination is the extraordinarily high percentage of aspartic acid obtained; namely, 9.23 per cent. As the amount obtained from the esters was only 5.70 per cent, it is highly indicative that the percentages of aspartic acid obtained in previous hydrolyses of proteins do not nearly represent the actual amount present.

The amount of glutaminic acid obtained by this method was somewhat lower than that obtained from the large hydrolysis, due to the fact that some of this amino-acid had been previously removed in the form of pyrrolidonecarboxylic acid, while making the proline determination.

The method outlined by Dakin will doubtless prove of great value in the further development of methods for the direct separation and determination of the products of hydrolysis of proteins.

EXPERIMENTAL.

A quantity of stizolobin, equivalent to 405 gm. of the ash and moisture-free protein, was hydrolyzed in two separate portions of 200 and 240 gm. each, with 1,300 cc. of hydrochloric acid (specific gravity 1.1), by first heating on a steam bath until nearly all the protein had dissolved. The hydrolysis was then continued by boiling the solutions in an oil bath for 30 hours. The solutions were then concentrated to about one-half their original volumes, and after removal of most of the color by treatment with norite, were saturated, cold, with dry hydrochloric acid gas. After standing for about a week at nearly 0°, the glutaminic acid hydrochloride was removed by filtration. There were finally obtained, after removal of ammonia with barium hydroxide in the usual way, 27.23 and 24.83 gm., respectively, of glutaminic acid hydrochloride, equivalent to a total of 41.72 gm. of the free acid. This amount, together with the 17.28 gm. subsequently isolated from the esters, is equivalent to 14.59 per cent of the stizolobin.

The glutaminic acid hydrochloride decomposed with effervescence at 197°. The free acid, obtained by decomposing the

hydrochloride with an equivalent amount of normal potassium hydroxide, decomposed at 202° and was analyzed with the following results:

0.1491 gm. of substance gave 0.2249 gm. of carbon dioxide and 0.0872 gm. of water.

	Calculated for C ₅ H ₉ O ₄ N.	Found.
C.....	40.80	41.14
H.....	6.12	6.54

The filtrates and washings from the above direct determination of glutaminic acid hydrochloride were united and concentrated to a heavy syrup. This residue was freed from water by repeated evaporations with alcohol under reduced pressure and esterified in the usual way, with the exception that no zinc chloride was used. After liberating the esters with sodium ethylate the sodium chloride was removed by centrifugation and the alcohol distilled from the esters under reduced pressure. The alcohol was reserved for further examination. On stirring the syrupy residue of esters with ether nearly all dissolved, but on dilution with more ether a flocculent precipitate separated which soon settled and formed a sticky, viscous layer. The addition of ether was continued until only a slight turbidity was produced. The ether extracts were filtered and dried in the usual way over anhydrous sodium sulfate.

The sodium chloride obtained from the alcoholic solution of the esters was dissolved in water and the solution saturated with hydrochloric acid gas. The salt which separated was removed by filtration. To the filtrate was added the above mentioned sticky residue which did not dissolve in the ether when extracting the esters. The solution was then subjected to a second esterification. The residue of ester hydrochlorides left after removing the alcohol by distillation was very viscous. It was therefore dissolved in enough absolute alcohol to form a thin syrup. After cooling to 0° the esters were liberated by the cautious addition of an aqueous 50 per cent solution of sodium hydroxide. The esters were extracted with ether and dried over anhydrous sodium sulfate to which was added a little powdered ammonium chloride.

The ether was removed from the esters by distillation at atmospheric pressure. 332 gm. of esters were obtained, 128 gm. of which were obtained from the second esterification.

Alcohol Distilled from the Esters.—The alcohol which had been distilled from the esters was acidified with hydrochloric acid and the solution evaporated to dryness under reduced pressure. The residue of ester hydrochlorides was hydrolyzed by boiling with dilute hydrochloric acid, and the solution evaporated to dryness. After expelling ammonia by boiling with barium hydroxide, and subsequent removal of barium and hydrochloric acid, there were obtained 8.48 gm. of amino-acids. The amino-acids insoluble in absolute alcohol weighed 6.66 gm. Both the proline and the other amino-acids were added to the corresponding portions of Fraction I of the distilled esters.

Ether Distilled from the Esters.—The ether distilled from the esters was strongly acidified with a dry alcoholic solution of hydrochloric acid, and allowed to stand at nearly 0° for several weeks. The white crystalline product which separated was boiled with barium hydroxide to remove ammonia. The barium and hydrochloric acid were then quantitatively removed, and after concentrating the solution to a small volume 3.81 gm. of glycine separated, which, for identification, was converted into its ethyl ester hydrochloride. The latter crystallized from alcohol in the characteristic long prisms or needles which melted sharply to a clear oil at 144°.

0.1987 gm. of substance required 14.15 cc. of 0.1 N sulfuric acid.

	Calculated for	Found.
	$C_4H_{10}O_2NCl$.	
N.....	10.04	10.03

The glycine thus obtained, together with that subsequently isolated from the distilled esters, amounted to 6.72 gm. or 1.66 per cent of the protein.

The amino-acids present in the form of their esters in the original ether filtrate from the glycine ester hydrochloride were regenerated and weighed 9.24 gm., of which 6.88 gm. were insoluble in absolute alcohol. The latter and the alcoholic extract of proline were added to similar portions of Fraction I of the distilled esters.

The esters obtained after distilling off the ether were separated into the following fractions in the usual way by distillation under reduced pressure:

Fraction.	Tempera- ture of the bath.	Tempera- ture of the vapors.	Pressure.	Weight.
	°C.	°C.	mm.	gm.
I.....	100	50	35	21
II.....	113	85	3	85
III.....	135	107	3	61
Distillation residue.....				131
Contents of the liquid air tube....				10

The contents of the liquid air tube were made strongly acid with hydrochloric acid and hydrolyzed by boiling for several hours. After expelling the ammonia with barium hydroxide and subsequent removal of barium and hydrochloric acid there were obtained 2.87 gm. of amino-acids, of which 2.04 gm. were insoluble in absolute alcohol. The latter were added to Fraction I.

Fraction I.—The esters of this fraction, which also contained some alcohol, were hydrolyzed in the usual way by boiling with water. There were obtained 4.64 gm. of amino-acids, 3.73 gm. of which were insoluble in absolute alcohol. To the latter were added the alcohol-insoluble amino-acids obtained from the following sources: (1) The alcohol distilled from the esters, 6.66 gm.; (2) the ether distilled from the esters, 6.88 gm.; (3) the contents of the liquid air tube, 2.04 gm.; (4) the precipitate which separated on standing from the united alcoholic extracts of proline, 2.30 gm. From this mixture were isolated by means of the lead salts, 5.62 gm. of leucine and 2.64 gm. of valine. The leucine had the following composition:

0.1825 gm. of substance gave 0.3678 gm. of carbon dioxide and 0.1671 gm. of water.

	Calculated for $C_6H_{13}O_2N$.	Found.
C.....	54.96	54.96
H.....	9.99	10.24

Analysis of the valine gave the following results:

0.1495 gm. of substance gave 0.2828 gm. of carbon dioxide and 0.1319 gm. of water.

	Calculated for $C_5H_{11}O_2N$.	Found.
C.....	51.28	51.59
H.....	9.47	9.80

The filtrates from the above leucine and valine were united, the amino-acids esterified and the resulting product was examined for glycine. There were obtained 5.0 gm. of glycine ester hydrochloride, equivalent to 2.69 gm. of glycine. The glycine ester hydrochloride crystallized from alcohol in the characteristic needles which melted sharply at 144°C.

The filtrate from the glycine ester hydrochloride, after having quantitatively removed the hydrochloric acid, yielded 7.37 gm. of alanine which crystallized in needles and prisms.

0.2028 gm. of substance gave 0.3004 gm. of carbon dioxide and 0.1377 gm. of water.

	Calculated for $C_3H_7O_2N$.	Found.
C.....	40.41	40.40
H.....	7.92	7.54

A small amount of glycine (0.22 gm.) was further separated (4) from the filtrate from the alanine, in the form of its picrate, which decomposed with effervescence at 195°C.

Fraction II.—This fraction yielded 52 gm. of amino-acids of which 42.6 gm. were insoluble in absolute alcohol. By direct fractional crystallization 16.50 gm. of leucine and 3.29 gm. of valine were obtained. Analysis of the leucine showed it to have the following composition:

0.1459 gm. of substance gave 0.2937 gm. of carbon dioxide and 0.1313 gm. of water.

	Calculated for $C_6H_{13}O_2N$.	Found.
C.....	54.96	54.90
H.....	9.99	9.99

The valine gave the following results on analysis:

0.1666 gm. of substance gave 0.3151 gm. of carbon dioxide and 0.1426 gm. of water.

	Calculated for $C_5H_{11}O_2N$.	Found.
C.....	51.28	51.58
H.....	9.47	9.51

A mixture of leucine and valine, after subjection to Levene and Van Slyke's lead salt method of separation, yielded 14.44 gm. of leucine and 2.43 gm. of valine.

A fraction was further obtained consisting of a mixture of alanine and valine. The amino-acids of this mixture were separated by means of phosphotungstic acid according to Levene and Van Slyke's method (2). 3.32 gm. of valine and 2.38 gm. of alanine were thus obtained.

All the alcoholic extracts of proline were united and allowed to stand for several days. The precipitate which had separated, after having been filtered off and washed with absolute alcohol, weighed 2.30 gm., and was added to the amino-acids of Fraction I. The clear solution was then evaporated to dryness under reduced pressure. The residue was completely soluble in cold absolute alcohol. The solution was again evaporated to dryness and the residue dissolved in water and made up to a volume of 500 cc. The total nitrogen in the solution was 2.6023 gm., and the amino nitrogen 0.7399 gm. The difference, or non-amino nitrogen, 1.8623 gm. corresponds to 15.30 gm. of proline, equivalent to 3.77 per cent of the proline. Special experiments for the direct determination of proline are described.

Fraction III.—Phenylalanine ester was separated from this fraction in the usual way by extraction with ether. After hydrolyzing the ester with hydrochloric acid, and decomposing the hydrochloride with ammonia, 4.16 gm. of phenylalanine were obtained.

0.1531 gm. of substance gave 0.3660 gm. of carbon dioxide and 0.0948 gm. of water.

	Calculated for	Found.
	$C_9H_{11}O_2N$.	
C.....	65.45	65.20
H.....	6.66	6.88

The esters remaining after the removal of the phenylalanine were hydrolyzed with barium hydroxide, and yielded 2.92 gm. of aspartic acid as the barium salt, and 15.80 gm. in the form of the copper salt. The free aspartic acid gave the following results on analysis:

0.1664 gm. of substance gave 0.2200 gm. of carbon dioxide and 0.0825 gm. of water.

	Calculated for	Found.
	$C_4H_7O_4N$.	
C.....	36.09	36.06
H.....	5.26	5.51

The copper aspartate was analyzed with the following results:

0.2503 gm. of substance (air-dried) gave 0.0717 gm. of copper oxide.

	Calculated for $C_7H_{12}O_4NCu \cdot 4H_2O$	Found.
Cu.....	23.07	22.90

There were also obtained 2.73 gm. of a substance which after several recrystallizations from water separated in the form of rather indefinite, microscopic, octagonal plates. Analysis showed these crystals to contain 35.20 per cent carbon, 7.00 per cent hydrogen, and 12.47 per cent nitrogen. The small amount of the substance in hand, and its high degree of solubility, prevented further examination of this material. Its solubility, crystalline form, sweetish taste, and composition, as above noted, leave little or no doubt that this substance was chiefly serine. Especially significant in supporting this conclusion is the high percentage of nitrogen found, as serine contains nearly 3 per cent more nitrogen than any of the other amino-acids usually found as products of protein hydrolysis, except proline. Serine theoretically contains 34.29 per cent carbon, 6.67 per cent hydrogen, and 13.33 per cent nitrogen.

Distillation Residue.—The residue remaining after the distillation of the esters was dissolved in water and shaken with ether to separate the phenylalanine, of which 8.41 gm. were obtained.

The aqueous layer was concentrated somewhat and sufficient concentrated hydrochloric acid added to make the solution about 25 per cent. This solution was boiled for 12 hours in order to hydrolyze any pyrrolidonecarboxylic acid that might be present. It was then concentrated to a small volume, and saturated cold with hydrochloric acid gas. After standing for a long time at 0°, 17.52 gm. of glutaminic acid hydrochloride were isolated. It decomposed with effervescence at 197°. The filtrates from the glutaminic acid hydrochloride were united and the bases removed with phosphotungstic acid. From the resulting solution, after removing the hydrochloric and phosphotungstic acids, there were further obtained 4.4 gm. of aspartic acid and 3.24 gm. of glutaminic acid.

Tyrosine.—Tyrosine was determined by the colorimetric method of Folin and Denis (5, 6). 1 gm. of stizolobin was boiled

for 12 hours with 20 per cent hydrochloric acid. The tyrosine was found to be equivalent to 6.24 per cent of the protein.

As the percentage of tyrosine obtained by this method is usually 2 or 3 per cent higher than that obtained by direct isolation of the amino-acid, due to the extreme difficulty of separating all the tyrosine from the other products of hydrolysis, a direct determination of tyrosine was made for comparison. 50 gm. of the protein were accordingly hydrolyzed with hydrochloric acid, and as much as possible of the latter was removed by distillation under reduced pressure. The calculated amount of normal potassium hydroxide to react with the chlorine remaining in the residue was then added. There were obtained from the resulting solution by careful fractional crystallization, 2.42 gm. of tyrosine, equivalent to 5.25 per cent of the protein. That not all the tyrosine was removed even then was indicated by the fact that the mother liquors still gave a strong positive test with Millon's reagent.

The tyrosine which was isolated gave the following results on analysis:

0.2036 gm. of substance required 11.2 cc. of 0.1 N HCl.

	Calculated for	Found.
	$C_9H_{11}O_3N$.	
N.....	7.73	7.72

Proline.—Several determinations of proline were made directly without involving the ester method of Fischer. The following procedure gave consistent results, which closely agreed with the percentage obtained by the ester method: 10 gm. of the protein are hydrolyzed by boiling with 20 per cent hydrochloric acid for about 30 hours. The solution is then concentrated under reduced pressure to a thick syrup, and the residue dissolved in water. After filtering off the suspended humin, the solution is made up to 200 cc. containing 3.5 per cent hydrochloric acid, and phosphotungstic acid added until all precipitation has ceased. After standing for 48 hours the precipitate is filtered off and washed in the usual way. Phosphotungstic acid is then removed from the filtrate by means of ether and amyl alcohol, and the solution of amino-acids boiled with a slight excess of barium hydroxide in order to remove any ammonia or phosphotungstic

acid that might be present. After filtering, the excess of barium is removed quantitatively with sulfuric acid and the solution made slightly alkaline with sodium hydroxide, in order to neutralize the hydrochloric acid present. The solution is then reacidified with acetic acid and evaporated to dryness, and the dry, finely powdered residue of amino-acids extracted by boiling with absolute alcohol for about $1\frac{1}{2}$ hours. The alcoholic extract is acidified with hydrochloric acid and the alcohol removed by distillation under reduced pressure. The residue is then boiled for 10 to 15 hours with 25 per cent hydrochloric acid to regenerate any glutaminic acid from pyrrolidonecarboxylic acid which may have been formed during the preceding operations. The solution is then freed from hydrochloric acid as completely as possible by distillation under reduced pressure, the residue dissolved in water and made slightly alkaline with sodium hydroxide, and then reacidified with acetic acid. The resulting solution is made up to 100 cc. and amino nitrogen and total nitrogen are determined in 10 cc. aliquot portions. From these data the amount of proline is calculated. Eight determinations of proline made in this way gave closely agreeing results the average of which was 4 per cent.

The Di-Basic Amino-Acids.—As the residues of the amino-acids remaining from some of the direct proline determinations were on hand they were examined for the di-basic amino-acids according to the method of Dakin (3). Four of these residues, which represented 40 gm. of stizolobin, were united and used for the analysis. The proline, ammonia, bases, and most of the tyrosine had been previously removed. The amino-acids were dissolved in about 600 cc. of water and extracted with butyl alcohol, according to Dakin's directions. The extraction was continued for about 38 hours, at the end of which time there were practically no more acids being carried over by the butyl alcohol. As the amount of material available for this extraction was too small for a complete analysis, the monoamino-acids which had been carried over by the butyl alcohol were not further examined. The aqueous solution which had been extracted was examined for glutaminic acid in the usual way. 4.41 gm. of glutaminic acid, isolated as the hydrochloride, were obtained. This corresponds to 11.02 per cent of the protein. This percentage is somewhat lower than that which we obtained from

the main hydrolysis. This was to be expected, since some of the glutamic acid was lost during the extractions for proline by being converted into pyrrolidonecarboxylic acid. The proline extract was always boiled with 25 per cent hydrochloric acid before determining amino nitrogen, and it was always found that some of the glutamic acid had been converted into pyrrolidonecarboxylic acid.

The amino-acids in the filtrate from the glutamic acid hydrochloride were converted into their calcium salts, according to Foreman's method (7), and the aspartic acid was isolated as the copper salt. An unusually large amount of the copper salt separated in the characteristic crystalline form. The air-dried salt weighed 7.69 gm., and without recrystallizing gave the following results on analysis:

0.2082 gm. of substance gave 0.0602 gm. of copper oxide.

	Calculated for $C_4H_5O_4NCu \cdot 4\frac{1}{2}H_2O$.	Found.
Cu.....	23.07	23.10

The above amount of copper aspartate is equivalent to 3.69 gm. of the free acid which is 9.23 per cent of the protein. This is 3.53 per cent more than was obtained from the esters.

Copper was removed from the filtrate from the copper aspartate, and the solution examined for hydroxyglutamic acid by precipitating the acid in the form of its silver salt, according to Dakin's method. There were obtained 2.63 gm. of the difficultly soluble silver salt, which is equivalent to 1.12 gm. of hydroxyglutamic acid, or 2.81 per cent of the protein.

0.2378 gm. of substance gave 0.1803 gm. of silver chloride.

	Calculated for $C_6H_7O_5NAg$.	Found.
Ag	57.26	57.07

SUMMARY.

The globulin of the Chinese velvet bean has been hydrolyzed and the percentages of the resulting amino-acids determined (see Table I).

A modification of the usual method of determining proline is described.

Aspartic acid was determined both by the usual ester method and by the method, recently published by Dakin, of extraction of the solution of amino-acids with butyl alcohol. The yield obtained by the former method was 5.70 per cent, while by the latter method the unusually high percentage of 9.23 per cent was obtained. By means of the extraction method 2.81 per cent of hydroxyglutaminic acid was also obtained.

BIBLIOGRAPHY.

1. Johns, C. O., and Finks, A. J., *J. Biol. Chem.*, 1918, xxxiv, 429.
2. Levene, P. A., and Van Slyke, D. D., *J. Biol. Chem.*, 1913-14, xvi, 103.
3. Dakin, H. D., *Biochem. J.*, 1918, xii, 290.
4. Levene, P. A., and Van Slyke, D. D., *J. Biol. Chem.*, 1912, xii, 285.
5. Folin, O., and Denis, W., *J. Biol. Chem.*, 1912, xii, 245.
6. Johns, C. O., and Jones, D. B., *J. Biol. Chem.*, 1918, xxxvi, 319.
7. Foreman, F. W., *Biochem. J.*, 1914-15, viii, 463.

THE NUTRITIVE VALUE OF THE BANANA. II.

BY KANEMATSU SUGIURA AND STANLEY R. BENEDICT.

(From the Huntington Fund for Cancer Research, Memorial Hospital, and the Harriman Research Laboratory, Roosevelt Hospital, New York.)

(Received for publication, October 10, 1919.)

Introduction and Object of the Investigation.

It has been shown in a preceding article¹ that bananas alone as a food do not produce growth of young albino rats. The addition of 16 per cent of purified casein, which supplied the protein deficiency of the food, and 0.5 per cent of yeast preparation, or of aqueous or alcoholic extract of fresh carrots, which supplemented the shortage of water-soluble accessory substance, constituted a complete diet for the growth, maintenance, and reproduction of albino rats. Such a diet was not adequate, however, for the production of proper milk by the mother. We stated that the addition of a small amount (10 cc.) of cow's milk to the mother's diet from the time of birth of the young until they are weaned is absolutely imperative, if the young are to survive and to maintain normal growth.

Further experiments on this point are shown in Tables I, II, and III, from which it is clearly seen that the new-born whose mothers were fed with a ration made up of bananas, casein, and yeast failed to grow and died from starvation, or were killed by the mother shortly after they were born, except in one instance where the young were reared but their body weights were very much below normal. The mother of these lost 10 gm. of her body weight during 1 month of lactation. On the other hand, the addition of cow's milk to the same diet made it a proper diet for the production of suitable milk during the period of lactation. The mothers maintained their body weights on this diet, and Rats 49 and 219 gained in body weight. The health and condition of these animals appeared normal in all respects.

¹ Sugiura, K., and Benedict, S. R., *J. Biol. Chem.*, 1918, xxxvi, 171.

The aim of the present investigation has been to study the unknown chemical substance or substances present in milk, which are indispensable for the growth of young animals during the period of lactation.

Review of Previous Investigations.

Of all foods, milk is the most important. It contains all the nutrients essential for growth. The important constituents of milk are water, fats, casein,² lactalbumin,^{3,4} lactoglobulin,^{4,5} lactose, lecithin,⁶ cholesterol,⁷ urea,⁸ ammonia,⁹ the purine bases, alcohol-soluble protein,¹⁰ inorganic salts, enzymes, and unidentified accessory factors.^{11,12} Many foreign substances, such as flavors, condiments, and stimulants, introduced with the food, are secreted in the milk.

A brief review of the more characteristic investigations relating to milk production of adult animals and to the subsequent growth of young may throw light on the nature of the catalytic substances present in milk.

Decaisne,¹³ during the siege of Paris, made an observation upon the milk production of forty-three women and the behavior of their infants. Twelve strong, healthy women had plenty of milk of good quality and their children obtained enough milk at the expense of catabolized tissue of the mothers. Fifteen women had little milk of poor quality. Their children became weak and had enteritis. Sixteen women had very little milk and more than three-fourths of the children died from starvation. Most of the forty-three women appeared to be suffering from malnutrition. Milk analyses revealed that the amount of fats, casein, milk-sugar, and salts was diminished while albumin increased as a result of insufficient nutrition.

McCollum and Davis¹⁴ have shown that young rats maintained normal growth for periods of 70 to 120 days on a ration of purified food substances

² Vernois, A.-G.-M., and Becquerel, A., *Ann. Hyg.*, 1853, xlix, 257; 1, 43.

³ Sebelien, J., *Z. physiol. Chem.*, 1885, ix, 445.

⁴ Halliburton, W. D., *J. Physiol.*, 1890, xi, 448.

⁵ Sebelien, J., *J. Physiol.*, 1891, xii, 95.

⁶ Stoklasa, J., *Z. physiol. Chem.*, 1897, xxiii, 343.

⁷ Filia, A., *Riv. clin. pediat.*, 1914, xii, 339.

⁸ Schöndorff, B., *Arch. ges. Physiol.*, 1900, lxxxi, 42.

⁹ Sherman, H. C., Berg, W. N., Cohen, L. J., and Whitman, W. G., *J. Biol. Chem.*, 1907, iii, 171.

¹⁰ Osborne, T. B., and Wakeman, A. J., *J. Biol. Chem.*, 1918, xxxiii, 7.

¹¹ Osborne, T. B., and Mendel, L. B., *Carnegie Institution of Washington, Publication No. 156*, 1911, pts. 1 and 2.

¹² Hopkins, F. G., *J. Physiol.*, 1912, xlv, 425.

¹³ Decaisne, E., *Gaz. méd.*, 1871, xxvi, 317.

¹⁴ McCollum, E. V., and Davis, M., *J. Biol. Chem.*, 1913, xv, 167.

consisting of casein, carbohydrate, and salt mixtures or the same ration in which a part of the carbohydrates was replaced by lard. Upon these rations females did not become pregnant; however, upon the addition of 1 gm. of ether extract of egg or butter, not only was growth resumed but they also became pregnant and gave birth to young. Some of the young animals were eaten by their mothers; others were reared but were very much undersized. The cause of the subnormal growth of young was due to the insufficient milk production of the mothers.

Osborne and Mendel,¹⁵ working with young white rats, found that the milk food, which consisted of milk powder, 60 per cent, starch, 12 per cent, and lard, 28 per cent, was an adequate diet and animals not only had grown from infancy to full maturity, but also gave birth to young which in turn thrived upon the same diet.

Hart and Humphrey,¹⁶ using two grades of Holsteins, showed that the nitrogen of alfalfa hay is quite efficient for milk protein building. From the fact that alfalfa hay contains a relatively small amount of acid amide nitrogen and a much greater amount of amino-acid nitrogen, they drew the conclusion that the real nutritive nitrogen value of alfalfa hay lay in the amino-acid nitrogen. They made¹⁷ a comparison of the relative efficiency of the ingestion of the proteins of milk, corn, and wheat grain on milk production; they found milk protein most effective and wheat grain least effective. During the negative nitrogen balance which followed corn or wheat protein ingestion they observed enhanced tissue autolysis. The production of milk remained the same both in volume and concentration for a short period at the expense of catabolized tissue.

McCollum, Simmonds, and Pitz¹⁸ found that young rats were able to grow normally upon a ration containing wheat, casein, dextrin, butter fat, and salt mixture. Females gave birth to litters of young, but the mothers failed to rear young on this diet. The lack of suitable milk production by the mother was due to the shortage of the water-soluble accessory factor in the milk. These results are the experimental proof of their earlier statement that the unidentified fat-soluble and water-soluble accessory substances of the diet "pass into the milk only as they are present in the diet of the mother, and that milks may vary in their growth-promoting power when the diets of the lactating animals differ widely in their satisfactoriness for the growth of young."¹⁹

Daniels and Nichols,²⁰ working with the soy bean rations, came to the conclusion that very young rats required a greater amount of fat-soluble accessory factor than adults to pass the early growing period successfully.

¹⁵ Osborne, T. B., and Mendel, L. B., *J. Biol. Chem.*, 1913, xv, 311.

¹⁶ Hart, E. B., and Humphrey, G. C., *J. Biol. Chem.*, 1914, xix, 127.

¹⁷ Hart, E. B., and Humphrey, G. C., *J. Biol. Chem.*, 1915, xxi, 239.

¹⁸ McCollum, E. V., Simmonds, N., and Pitz, W., *J. Biol. Chem.*, 1916-17, xxviii, 211.

¹⁹ McCollum, E. V., Simmonds, N., and Pitz, W., *J. Biol. Chem.*, 1916, xxvii, 33.

²⁰ Daniels, A. L., and Nichols, N. B., *J. Biol. Chem.*, 1917, xxxii, 91.

Loeb and Northrop²¹ have been able to show that the imago of the fruit fly (*Drosophila*) can live on "glucose-agar" alone, while the larvæ cannot grow on "glucose-agar" unless yeast is added. The larvæ needed an adequate diet for body building while the imago, the full grown organism, appeared to be in no need of such growth-inducing substances as are present in yeast.

Stepp²² has pointed out that the substance in cow's milk, which in minute quantities suffices to induce normal growth of young mice when added to an inadequate diet, is not fat, cholesterin, lecithin, or salts.

Meigs and Marsh²³ obtained two unknown substances from cow's milk, one alcohol-soluble and the other ether-soluble, which are claimed to be important constituents of diets. The former substance contained 13.8 per cent of nitrogen and its ash showed the presence of phosphorus; while the latter contained no nitrogen, but contained a considerable amount of sulfur. The amount of these substances diminished with the progress of lactation.

Methods and Material Employed.

The albino rats used by us were raised in our own laboratory. They were fed with wheat bread soaked in whole milk, fresh carrots, and occasionally a small amount of fresh meat (beef). This normal diet was designated as Ration X.

The animals were from 90 to 300 days old. This includes the period of rapid growth and the attainment of maturity. Also the most successful reproductions occur in this period. Pregnant animals on a normal diet were placed in separate metal cages, having sawdust- and newspaper-sprinkled floors, as soon as their condition was discovered and were put on the special diets which were continued until the end of the experimental period. In choosing the pregnant females among normally fed animals, care was taken to select only those in good health. A large number of pregnant rats were fed with the normal diet at the same time that the experimental diets were being investigated.

The animals were weighed together upon the day of birth (less than 12 hours after birth) and every alternate day. The size of the litter as well as the physical condition and body weight of the mother at the birth of the young and during the experi-

²¹ Loeb, J., and Northrop, J. H., *J. Biol. Chem.*, 1917, xxxii, 103.

²² Stepp, W., *Z. Biol.*, 1911-12, lvii, 135.

²³ Meigs, E. B., and Marsh, H. L., *J. Biol. Chem.*, 1913-14, xvi, 147.

mental period were recorded. The sex of the new-born animals was determined by the method devised by Jackson.²⁴

It is a well known fact that generally male albino rats weigh more than females throughout life. King²⁵ has found in 85 litters examined that the average weight at birth of the male albino rats is 4.54 gm., and that of the females is 4.27 gm.; while Jackson²⁴ reported 5.13 gm. for males and 4.89 gm. for females in 63 and 66 animals respectively. The different factors which might influence the body weight of the albino rats at birth are summarized by King as follows: (a) The age of the mother; (b) the physical condition of the mother; (c) the body weight of the mother; (d) the size of the litter; (e) the position of the litter in the litter series; and (f) the length of the gestation period.²⁵

King's interesting graphic comparison²⁶ shows that during the first 60 days the growth curve of female albino rats runs very closely to the growth curve of the males, but then the curves begin to separate rapidly; *i.e.*, males surpassing females in body weight.

We have not attempted to weigh young males and females separately during the first 30 days for two reasons: first, there is no object in the determination of the body weights at definite ages; second, we are interested only in seeing what difference there is in the body weight and general condition of the young when the mother's diet is changed to the experimental diet.

The relative effective value of foods was determined by the change in the body weights of young rats at seven selected ages; namely, at birth, and on the 5th, 10th, 15th, 20th, 25th, and 30th days, and comparing these weights with those of young whose mothers were fed on a normal diet.

The following rations were employed in this investigation and the methods of preparation for the individual food substances are discussed in detail.

²⁴ Jackson, C. M., *Biol. Bull.*, 1912, xxiii, 171.

²⁵ King, H. D., *Anat. Rec.*, 1915, ix, 213.

²⁶ King, H. D., *Anat. Rec.*, 1915, ix, 751.

Ration N.

Bread.
Carrots.
Milk.

Ration Y.

	<i>per cent</i>
Bananas	83.5
Casein	16.0
Yeast	0.5

Ration M.

	<i>per cent</i>
Bananas	83.5
Casein	16.00
Yeast	0.5
Milk	10.0 cc. each animal.

Ration P.

	<i>per cent</i>
Bananas	83.0
Casein	16.0
Yeast	0.5
Protein-free milk	0.5

Ration S.

	<i>per cent</i>
Bananas	83.22
Casein	16.00
Yeast	0.50
Salt mixture	0.28

Ration N.S.

	<i>per cent</i>
Bananas	83.22
Casein	16.00
Yeast	0.50
Natural salt mixture	0.28

Ration L.

	<i>per cent</i>
Bananas	83.00
Casein	16.00
Yeast	0.50
Lactose	0.50

Bananas.—In a recent article Hess and Unger²⁷ have shown that fresh young vegetables possess a much greater amount of antiscorbutic and growth-promoting substances than old vegetables.

²⁷ Hess, A. F., and Unger, L. J., *J. Biol. Chem.*, 1919, xxxviii, 293.

Abderhalden and Lampé²⁸ and Funk²⁹ showed that cooked polished rice took much longer to produce polyneuritis in pigeons than uncooked polished rice. They suggested that the beneficial action of the cooked rice was due partly to the intake of relatively smaller amounts of carbohydrate by the birds.

In a preliminary communication,¹ we have reported that a banana diet maintained the life of young albino rats much longer than when fed on carrots as the sole food. We believed that the difference in the nutrition of young animals when fed upon these closely allied forms of foods is due partly to a difference in the degree of digestibility. Another example of how easily digestible foods influence the maintenance of animal life is seen in the fact that rats can live very much longer on the cooked white potato (Irish) than on uncooked potato. Detailed investigation on the nutritive value of potato will be given in a later paper. Throughout the experiments we used only the edible portion of well ripened, golden yellow bananas.

Casein.—McCullum and Davis have purified casein without any application of high temperature since they learned that the prolonged heating even at temperatures of 90–100°C. causes deterioration of the nutritive properties of milk. The growth curves showed the absence of unknown growth-promoting substances in their purified casein.³⁰ They have observed that heating casein in a moist condition for 1 hour in an autoclave at 15 pounds pressure destroys its biological value as a complete protein.³¹ This particular point is true when a ration contained 5 per cent casein,³² but when a ration contained 10 per cent casein,³³ the difference of the nutritive value in the heated and unheated casein is not clearly shown.

Funk and Macallum,³⁴ in order to free commercial casein from the traces of unknown accessory substances, extracted it by

²⁸ Abderhalden, E., and Lampé, A. E., *Z. ges. exp. Med.*, 1913, i, 296.

²⁹ Funk, C., *Z. physiol. Chem.*, 1914, lxxxix, 373.

³⁰ McCullum, E. V., and Davis, M., *J. Biol. Chem.*, 1915, xxiii, 231.

³¹ McCullum, E. V., and Davis, M., *J. Biol. Chem.*, 1915, xxiii, 247.

³² McCullum and Davis, ³¹ Chart 5.

³³ McCullum and Davis, ³¹ Chart 6.

³⁴ Funk, C., and Macallum, A. B., *Z. physiol. Chem.*, 1914, xcii, 13; *J. Biol. Chem.*, 1916, xxvii, 51.

refluxing for 6 hours with boiling 95 per cent alcohol. They found that the process did not alter the nutritive properties of the protein.

Drummond³⁵ has extracted the dried caseinogen with two changes of alcohol for 6 hours at 60°C., and then with ether for 6 hours. This method of purification did not make it unsuitable for the rats. However, he has observed in two cases that when the caseinogen was extracted with hot alcohol in a slightly moist condition, there was some chemical change and it lost its protein value.

The casein we employed was prepared from commercial, washed casein by boiling for 2 hours with 95 per cent ethyl alcohol. It was filtered after standing over night at room temperature and the casein washed well with fresh alcohol and then allowed to dry in the air. A former experiment³⁶ showed clearly that our purified casein was free from unidentified accessory factors, it was not toxic, and it possessed full biological value as a complete protein.

Yeast.—The shortage of water-soluble accessory substance in bananas was supplied from yeast.^{37,38} Fresh yeast³⁹ was filtered, pressed, dried in the air at room temperature, and was then well ground. During drying, mold has generally grown on the surface of the yeast.

Protein-Free Milk.—The fact that young white rats have failed to grow upon the isolated food substances, but rapid recovery of health and growth have followed when 28 per cent of protein-free milk has replaced the inorganic elements and a part of the carbohydrate in food, led Osborne and Mendel to conclude that their natural protein-free milk contains unidentified water-soluble accessory substances.⁴⁰ Later Osborne and Mendel³⁸

³⁵ Drummond, J. C., *Biochem. J.*, 1916, x, 89.

³⁶ Sugiura, K., and Benedict, S. R., *J. Biol. Chem.*, 1919, xxxix, 421, Experiment 1.

³⁷ Funk, C., and Macallum, A. B., *J. Biol. Chem.*, 1915, xxiii, 413.

³⁸ Osborne, T. B., and Mendel, L. B., *J. Biol. Chem.*, 1917, xxxi, 149.

³⁹ The yeast was obtained from the Lion Brewery, New York City.

⁴⁰ Osborne, T. B., and Mendel, L. B., *Carnegie Institution of Washington, Publication No. 156*, 1911, pt. 2; *Z. physiol. Chem.*, 1912, lxxx, 356; *J. Biol. Chem.*, 1912, xii, 473; 1913, xv, 311; 1915, xx, 351; 1916, xxvi, 1.

have shown that the protein-free milk appeared to contain a new unidentified accessory substance which is not present in yeast.

We have prepared natural protein-free milk from fresh skimmed milk⁴¹ according to the procedure used by Osborne and Mendel.⁴² Different chemical analyses show that the contents of our preparations are nearly the same as those found by Osborne and Mendel.

Salt Mixtures.—The importance of the individual inorganic salts in the rôle of nutrition has been clearly shown and discussed.^{42, 43} Our artificial salt mixture was prepared according to Osborne and Mendel.⁴⁴ The natural salt mixture was prepared by igniting our protein-free milk until entirely free from carbon. The inorganic residue gave 14.3 per cent of the original material.

Lactose.—Hopkins and Neville,⁴⁵ Sweet, Corson-White, and Saxon,⁴⁶ McCollum and Davis,⁴⁷ and Drummond³⁵ have clearly shown that the lactose, prepared from milk, may contain traces of impurities which act as a growth-promoting substance, and such substances can be removed by means of purification with 95 per cent alcohol.

We have purified lactose (Merck) by means of recrystallization from ethyl alcohol. The crystalline lactose was dried in a vacuum desiccator over sulfuric acid.

⁴¹ The milk was obtained from the Walker-Gordon Laboratory Company, New York City.

⁴² Osborne, T. B., and Mendel, L. B., *Carnegie Institution of Washington, Publication No. 156*, 1911, pt. 2.

⁴³ Röhlmann, F., *Allg. med. Central.-Z.*, 1908, lxxvii, 129. McCollum, E. V., *Am. J. Physiol.*, 1909-10, xxv, 120. Evvard, J. M., Dox, A. W., and Guernsey, S. C., *Am. J. Physiol.*, 1914, xxxiv, 312. Hart, E. B., and McCollum, E. V., *J. Biol. Chem.*, 1914, xix, 373. Hogan, A. G., *J. Biol. Chem.*, 1916, xxvii, 193. Osborne, T. B., and Mendel, L. B., *J. Biol. Chem.*, 1918, xxxiv, 131. Steenbock, H., Kent, H. E., and Gross, E. G., *J. Biol. Chem.*, 1918, xxxv, 61. Sherman, H. C., *Chemistry of food and nutrition*, New York, 2nd edition, 1918, 234.

⁴⁴ Osborne, T. B., and Mendel, L. B., *J. Biol. Chem.*, 1913, xv, 317, Salt Mixture IV, minus the lactose.

⁴⁵ Hopkins, F. G., and Neville, A., *Biochem. J.*, 1913, vii, 97.

⁴⁶ Sweet, J. E., Corson-White, E. P., and Saxon, G. J., *J. Biol. Chem.*, 1915, xxi, 309.

⁴⁷ McCollum, E. V., and Davis, M., *J. Biol. Chem.*, 1915, xxiii, 181.

Experimental Results.

Our experimental results are compiled in Tables I to VII.

From the experiments we obtained the following facts:

(1) The comparative number of young born per litter from mothers fed with different rations is summarized in Table VIII. (2) The average number of days when the young from mothers fed on the different diets opened their eyes was noted and found to be 15.6 for Ration N, 16.0 for Ration Y, 16.0 for Ration M, 15.6 for Ration P, and 15.9 for Ration L. (3) The total per cents of young rats which were born under the following diets and which have thrived during the experimental periods of 30 days were found to be with the normal diet, 71; with Ration Y, 20; with Ration M, 87; with Ration P, 71; and with Ration L, 26. (4) The addition of 0.5 per cent of protein-free milk to the mother's diet, which consisted of bananas, 83.0, casein, 16.0, and yeast, 0.5 per cent, not only maintained her body weight throughout the lactation period, but also gave excellent milk supply both in quantity and quality (Table IV). (5) The amount of the food, Ration P, eaten by the mother during the lactation period increased as lactation progressed. (6) The addition of 0.28 per cent of salt mixture, either artificial or natural, had no beneficial action upon the banana-casein-yeast diet (Tables V and VI). (7) The addition of 0.5 per cent of purified lactose to the banana-casein-yeast diet increased slightly its nutritive value. A small number of young were reared by the mothers on this diet, but their body weights were very much below normal (Table VII). (8) Table IX shows more clearly the relative effective value of foods. The weights are the average of the rats which survived during the experimental periods. These figures are compiled from Tables I to VII.

TABLE I.
Ration N.—Bread, Carrots, Milk.

Mother.		No. of litter.		Average body weight of males and females together.							Remarks.
No.	Body weight. gm.	Males.	Females.	Birth.	5th day.	10th day.	15th day.	20th day.	25th day.	30th day.	
60	147	4	6	3.81	5.66	7.45	9.83	13.30	17.27	22.08	1 ♀ died on the 17th; 1 ♂ on the 18th; 1 ♀ on the 21st day; rest grew; somewhat undersized. 1 ♂ died shortly after birth; rest died on the 2nd day.
60	160	5	5	3.90	*						
282	130	4	5	4.93	7.23	10.72	13.93	17.72	21.50	24.18	Animals grew well; general condition excellent. 1 ♀ died shortly after birth; rest killed and eaten on the 12th day.
283	178	4	3	5.21	9.70	13.59	†				
294	204	2	3	5.62	10.17	16.76	24.15	32.92	41.74	47.04	Animals grew well; general condition excellent. " " somewhat undersized.
219	138	7	1	5.00	7.41	10.12	11.55	13.26	17.52	21.80	
104	178	7	1	4.85	8.05	11.27	14.79	18.18	21.96	24.05	" " well; general condition excellent. Killed and eaten on the 17th day.
374	198	9	3	5.03	8.04	10.91	13.26	†			
376	144	4	5	4.35	7.31	12.26	16.33	20.29	25.01	31.77	1 ♂ and 1 ♀ eaten on the 2nd day; rest grew well; general condition excellent. Animals grew well; general condition excellent.
377	163	5	5	4.74	7.26	11.12	14.94	19.91	24.45	30.89	
431	153	5	3	5.09	7.74	10.51	13.63	18.05	22.90	28.30	" " " " " " " " " " " "
445	106	3	1	5.15	8.39	12.92	18.25	25.40	32.90	41.00	
249	167	7	3	4.34	5.77	8.19	11.18	14.59	17.99	22.09	" " somewhat undersized. " " well; general condition excellent.
481	225	4	2	5.98	11.04	17.90	25.20	32.98	43.34	51.84	

* Died.

† Animals were killed and eaten by mother.

TABLE II.
Ration Y.—Bananas 83.5, Casein 16.0, Yeast 0.5 Per Cent.

No.	Mother.	Body weight.	No. of litter.		Average body weight of males and females together.										Remarks.
			Males.	Females.	Birth.	5th day.	10th day.	15th day.	20th day.	25th day.	30th day.				
		gm.			gm.	gm.	gm.	gm.	gm.	gm.	gm.	gm.	gm.	gm.	
65		126	3	2	4.33	*									2 ♂ died on the 1st day; 1 ♂ and 1 ♀ on the 3rd day; 1 ♀ on the 4th day.
77		117	2	0	5.01	*									All died on the 1st day.
65		117	4	5	2.93	*									2 ♀ died on the 1st day; rest died on the 2nd day.
193†		128	3	3	4.45	6.00	6.02	*							2 ♀ and 1 ♂ died on the 9th; on the 11th 1 ♂; on the 12th 1 ♂ and 1 ♀.
219†		135	5	7	3.73	6.13	8.43	10.48	11.33	12.62	16.53				1 ♂ died on the 26th day, and 1 ♂ eaten; rest poor and development retarded.
220†		103	5	4	4.16	5.13	7.28	9.40	11.03	†					3 ♂ and 2 ♀ died on the 21st day, and 1 ♂ and 2 ♀ eaten; on the 22nd day 1 ♂ died.
62†		125	3	4	4.39	4.00	†								1 ♂ died on the 2nd day; 1 ♂ died and 1 ♀ eaten on the 4th; on the 6th 3 ♀ died and 1 ♂ eaten.

* Died.

† Animals were on normal diet when they became pregnant.

‡ Animals were killed and eaten by mother.

TABLE III.
Ration M.—Bananas 83.5, Casein 16.0, Yeast 0.5 Per Cent and Milk 10 Cc. for Each Animal.

Mother. No.	No. of litter.		Average body weight of males and females together.							Remarks.
	Males.	Females.	Birth.	5th day.	10th day.	15th day.	20th day.	25th day.	30th day.	
	gm.		gm.	gm.	gm.	gm.	gm.	gm.	gm.	
49*	132	4	3.98	7.00	8.86	13.38	17.18	21.78	26.13	2 ♂ and 2 ♀ died on the 2nd day; rest grew well; general condition excellent.
91*	124	5	4.02	6.72	9.57	11.63	12.82	15.80	19.15	Animals grew; somewhat undersized.
283†	151	2	5.05	7.44	13.14	17.43	22.00	26.95	32.17	“ “ well; general condition excellent.
219†	144	3	4.27	6.60	9.86	12.27	17.91	22.09	28.14	“ “ “ “ “ “

* Animals were on Ration Y when they became pregnant.

† Animals were on normal diet when they became pregnant.

TABLE IV.
Ration P. — Bananas 83.0, Casein 16.0, Yeast 0.5, Protein-Free Milk 0.5 Per Cent.

Mother, No.	Body weight, gm.	No. of litter.		Average body weight of males and females together.							Remarks.
		Males.	Fe- males.	Birth.	5th day.	10th day.	15th day.	20th day.	25th day.	30th day.	
65*	123	3	2	4.80	6.64	9.94	13.67	16.97	23.31	32.89	Animals grew well; general condition excellent.
210	124	1	5	4.35	7.35	11.55	15.50	19.72	26.96	32.91	" " " "
222*	130	4	3	4.22	†						All died on the 1st day.
49†	139	4	3	4.29	6.77	11.52	15.26	18.54	27.12	36.17	Animals grew well; general condition excellent.
101†	183	1	7	5.15	8.35	11.92	14.32	15.78	20.31	24.20	General condition poor and development re- tarded.
196*	143	2	3	4.91	10.67	16.14	20.64	27.16	38.11	45.51	Animals grew well; general condition excellent.
248*	152	4	3	5.01	8.83	12.46	†				1 ♂ died on the 2nd day; during 11th day all eaten.

* Animals were on normal diet when they became pregnant.

† Died.

‡ Animals were killed and eaten by mother.

TABLE V.
Ration S.—Bananas 83.22, Cascin 16.00, Yeast 0.50, Salt Mixture 0.28 Per Cent.

Mother.	No. of litter.		Average body weight of males and females together.							Remarks.
	Body weight.	Males.	Fe-males.	Birth.	5th day.	10th day.	15th day.	20th day.	25th day.	
	<i>gm.</i>			<i>gm.</i>	<i>gm.</i>	<i>gm.</i>	<i>gm.</i>	<i>gm.</i>	<i>gm.</i>	<i>gm.</i>
214*	117	4	3	4.06	†					
217*	108	4	4	3.53	†					
282*	142	2	3	4.88	5.24	†				

* Animals were on normal diet when they became pregnant.

† Died.

‡ Animals were killed and eaten by mother.

1 ♂ and 1 ♀ died shortly after birth; rest died on the 2nd day.
 3 ♂ and 2 ♀ died on the 1st day; rest died on the 2nd day.
 All eaten on the 6th day.

TABLE VI.
Ration N.S.—Bananas 83.22, Cascin 16.00, Yeast 0.50, Natural Salt Mixture 0.28 Per Cent.

Mother.	No. of litter.		Average body weight of males and females together.							Remarks.
	Body weight.	Male.	Fe-male.	Birth.	5th day.	10th day.	15th day.	20th day.	25th day.	
	<i>gm.</i>			<i>gm.</i>	<i>gm.</i>	<i>gm.</i>	<i>gm.</i>	<i>gm.</i>	<i>gm.</i>	<i>gm.</i>
376*	198	5	3	4.07	5.28	†				
374*	162	2	4	4.32	†					

* Animals were on normal diet when they became pregnant.

† Died.

‡ Animals were killed and eaten by mother.

1 ♂ and 1 ♀ died on the 3rd; on the 4th 2 ♂ and 1 ♀; and on the 6th the rest died.
 Killed and eaten on the 2nd day.

TABLE VII.
Ration I.—Bananas 83.0, Casein 16.0, Yeast 0.5, Lactose 0.5 Per Cent.

No. *	Moth. †	No. of litter.	Average body weight of males and females together.										Remarks.
			Body weight gm.	Male.	Female.	Birth.	5th day.	10th day.	15th day.	20th day.	25th day.	30th day.	
60	157	5	3	4.22	†	gm.	gm.	gm.	gm.	gm.	gm.	gm.	Eaten on the 2nd day.
234	111	2	3	4.64	7.00	10.04	13.71	16.25	19.24	20.52	Animals grew; somewhat undersized.		
217	121	2	4	5.14	4.70	†					1 ♀ died on the 5th; on the 6th day 2 ♂ and 2 ♀ died and 1 ♀ eaten.		
219	142	?		†							Killed and eaten by mother.		
280	131	6	2	3.87	4.62	†					2 ♂ died on the 2nd day; on the 3rd 2 ♂ and 1 ♀ eaten; on the 6th 1 ♂ and 1 ♀ eaten; rest died on the 7th day.		
220	131	5	2	4.13	5.76	7.43	8.89	9.97	11.86	13.63	General condition poor; development retarded.		
217	142	3	3	5.00	6.00	†					All young died during the 8th day.		
378	127	5	2	5.32	7.33	8.58	7.58	8.35	†		2 ♂ and 1 ♀ died on the 15th day; on the 16th 1 ♀; on the 20th day 3 ♂.		
385	151	2	4	5.02	7.03	10.50	14.44	19.18	23.62	28.09	Animals grew well; general condition excellent.		
411	119	5	4	4.21	7.04	9.79	16.68	19.58	23.13	27.90	1 ♀ eaten on the 2nd day; on the 3rd 1 ♂ eaten; on the 9th 1 ♀; on the 11th day 1 ♂ died; rest grew well; general condition excellent.		
341	113	3	3	3.93	5.37	7.03	6.75	6.23	†		1 ♂ died shortly after birth; on the 2nd 1 ♀; 1 ♂ on the 17th; 1 ♀ on the 18th; rest died on the 20th day.		
374	155	2	3	4.02	†						Mother ate all on the 2nd day.		

473	152	2	6	4.78	6.90	7.25	8.30	8.65	9.79	10.60	1 ♂ eaten on the 2nd day; on the 13th 1 ♀ died; on the 24th 2 ♀ died; on the 28th 1 ♀; on the 29th 2 ♀ eaten; rest, general condition poor; development retarded.
376	190	5	3	4.81	7.66	12.18	15.26	17.48	19.64	22.66	2 ♂ eaten on the 2nd day; on the 6th day 1 ♂ eaten; rest grew, somewhat undersized.
249	130	6	4	3.30	†						5 eaten on the 1st day; on the 2nd 1 ♂ and 1 ♀; on the 3rd 1 ♂ and 1 ♀; on the 4th 1 ♂. All young died on 7th day.
276	115	6	0	4.03	4.13	†					“ “ “ “ 8th “
341	118	4	3	4.57	4.38	†					1 ♂ eaten shortly after birth; on 2nd day 1 ♂ and 2 ♀ eaten; rest grew well; general condition excellent.
385	116	3	2	4.59	7.12	11.82	16.05	22.16	26.24	29.82	

* All animals were on normal diet when they became pregnant.

† Animals were killed and eaten by mother.

‡ Died.

TABLE VIII.

Mother's ration.	No. of litters examined.	Average no. of young per litter.
N.	14	8.3
Y.	7	7.1
M.	4	7.8
P.	7	6.9
S.	3	6.7
N.S.	2	7.0
L.	18	6.5

TABLE IX.

Day of determination.	Weight of rats on experimental diets.						
	Ration N	Ration Y.	Ration M.	Ration P.	Ration S.	Ration N. S.	Ration L.
	gm.	gm.	gm.	gm.	gm.	gm.	gm.
Birth.	4.86	4.14	4.33	4.68	4.16	4.20	4.45
5th.	7.98	5.32	6.94	8.10	5.24	5.28	6.07
10th.	11.82	7.24	10.36	12.26	*	*	9.40
15th.	15.59	9.94	13.68	15.88			12.03
20th.	20.60	11.18	17.48	19.63			14.21
25th.	26.05	12.62	21.66	27.16			19.07
30th.	31.37	16.53	26.40	34.34			21.89

* Died.

DISCUSSION.

Our results show that whole milk, or protein-free milk is effective in making a banana-casein-yeast diet complete for milk production.

According to Osborne and Mendel,¹¹ their protein-free milk contains 0.48 per cent of non-protein nitrogen, and 0.28 per cent of protein nitrogen. They have stated that the amount of milk protein in the protein-free milk was not the cause of inducing the growth of the retarded animals. On the other hand, McCollum and Davis¹⁵ argue that the nitrogen of the protein-free milk is equivalent to milk protein nitrogen as a nutrient for young rats. Osborne and Mendel¹⁵ answer the criticism of McCollum

¹⁵ McCollum, E. V., and Davis, M., *J. Biol. Chem.*, 1915, xx, 641.

and Davis by showing very remarkably different chemical properties possessed by the protein-free milk and yeast. They say:

“On a ration of purified casein, ‘artificial protein-free milk,’ starch, lard, butter fat, and 1.5 per cent of dried yeast, rats of both sexes have grown from about 50 gm. body weight to maturity, and have even produced young. . . . Adult rats have been maintained for more than 300 days. For some as yet unknown reason the majority of the rats grew normally when the protein used was casein, whereas they have usually failed when it was edestin, and almost invariably when lactalbumin, cotton seed globulin, cotton seed proteins, or squash seed globulin was fed. This result surprised us because all of these proteins⁴⁹ had earlier led to normal growth when used in rations containing natural ‘protein-free milk.’ ”

From these experiments, Osborne and Mendel make the suggestion that the unknown nitrogenous constituents in the protein-free milk may supply the unrecognized deficient substances in these proteins. Assuming Osborne and Mendel's figures to be correct, we added only 0.0088 per cent of milk protein from the protein-free milk. We believe this amount does not exercise any influential effect upon the nutritive efficiency of the dietary.

Interesting investigation on the nature of lactalbumin as a complete protein has been made by Emmett and Luros.⁵⁰ They concluded, from the fact that lactose supplemented lactalbumin, that the former either acted as a buffer to overcome the toxicity present in the diet, or it adsorbed a new water-soluble growth-promoting substance.

In a recent paper, Kennedy⁵¹ has reported that protein-free milk contains “either unprecipitated protein, or peptids of considerable size.”

CONCLUSIONS.

1. A diet consisting of bananas, 83.0 per cent, casein, 16.0 per cent, yeast, 0.5 per cent, and protein-free milk, 0.5 per cent is an adequate diet for the growth, maintenance, reproduction, and perfect milk production of the albino rats.

⁴⁹ Osborne, T. B., and Mendel, L. B., *J. Biol. Chem.*, 1912, xii, 473; 1915, xx, 351; 1916, xxvi, 1.

⁵⁰ Emmett, A. D., and Luros, G. O., *J. Biol. Chem.*, 1919, xxxviii, 147.

⁵¹ Kennedy, C., *J. Am. Chem. Soc.*, 1919, xli, 388.

2. Protein-free milk contains a substance which is needed for suitable milk production by the mother.

3. This substance appears not to be associated with purified milk-sugar or inorganic constituents of milk.

4. This peculiarity possessed by the protein-free milk indicates that it contains a new accessory substance which is lacking in yeast.

5. Our experiments suggest that a combination of bananas and milk, in proper proportion, constitutes a complete food.

FURTHER CONTRIBUTIONS TO THE PHYSIOLOGY OF PHOSPHORUS AND CALCIUM METABOLISM OF DAIRY COWS.*

BY EDWARD B. MEIGS, N. R. BLATHERWICK, AND C. A. CARY.

WITH THE COLLABORATION OF T. E. WOODWARD.

(From the Research Laboratories of the Dairy Division, Bureau of Animal Industry, United States Department of Agriculture.)

(Received for publication, September 24, 1919.)

Recent work has made it seem probable that the amount of calcium and phosphorus contained in the rations of dairy cows is a matter of great practical importance. In a comprehensive series of experiments on liberally milking cows, Forbes and co-workers¹ have found that the calcium balances were always negative and the phosphorus balances usually so; and this in spite of the fact that the rations were liberal and, in many cases, contained more calcium and phosphorus than is ordinarily fed even to high producing cows.

In view of these and other results with the same general tendency, it seems desirable that calcium and phosphorus metabolism in dairy cows be intensively studied; and we have recently carried out a series of experiments on cows in which the calcium, phosphorus, and nitrogen balances were followed.

Objects of the Experiments.

Our experiments were planned to throw light on a number of points. It has been the custom at the Government Farm at Beltsville, Md., as it probably is on most dairy farms, to feed cows according to their milk yield. As the milk yield decreases

*Published with the permission of the Secretary of Agriculture.

¹ Forbes, E. B., Beegle, F. M., Fritz, C. M., Morgan, L. E., and Rhue, S. N., *Ohio Agric. Exp. Station, Bull. 295*, 1916; *ibid.*, *Bull. 308*, 1917. Forbes, E. B., Halverson, J. O., and Morgan, L. E., *ibid.*, *Bull. 330*, 1918.

with the progress of lactation, the feed—particularly the grain—is reduced, and reaches its lowest point when the cow becomes altogether dry, generally only a few weeks before the next calf is born. The routine ration fed to the dry cows at Beltsville is shown in Table III, as the ration fed to Cow 51 from February 17 to March 10, 1919. It contains sufficient protein, fat, and carbohydrate to provide liberally for the maintenance of the cow and the growth of the unborn calf, as calculated from the figures given in the standard text-books.

In most dairy rations, the grain contains a large proportion of the phosphorus, and the ration in question is no exception to this rule (Table V). As it is the grain which is chiefly reduced in the rations of the dry cows, it becomes an interesting question whether these cows receive sufficient phosphorus to provide for the optimum milk yield in the next lactation.

We have recently reported experiments in which the concentration of phosphorus in the blood plasma of dry, pregnant cows has been followed.² Though the cows were fed a much higher grain ration than the one in question, there was nevertheless a decided tendency for the concentration of phosphorus in the blood plasma to fall off toward the end of pregnancy. In other unpublished experiments, we have found that this tendency is more marked when the grain ration is lower.

We are engaged at present in carrying out experiments to determine whether the ration described above can be improved from the practical standpoint by adding sodium phosphate to it, and by feeding it in a manner which we judged would facilitate the absorption of phosphorus. There is considerable evidence to show that the absorption of phosphorus from the intestinal tract may be hindered by the simultaneous presence of calcium compounds.^{3,4} We have, therefore, attempted to separate the calcium

² Meigs, E. B., Blatherwick, N. R., and Cary, C. A., *J. Biol. Chem.*, 1919, xxxvii, 1. The experiments in question are referred to on pp. 45 and 46.

³ Hammarsten, O., A text-book of physiological chemistry, translated by Mandel, J. A., New York and London, 7th edition, 1915, 762. Forbes, E. B., with collaborators, *Ohio Agric. Exp. Station, Techn. Bull. 6*, 1915, 66.

⁴ Bertram, J., *Z. Biol.*, 1878, xiv, 335.

and phosphorus compounds in the intestinal tract by feeding the grain and hay of the rations on alternate days. This method of feeding is shown in Table III as the ration fed to Cow 63 from February 17 to March 10.

The milk yield of cows fed, for several weeks before calving, in this manner has been compared with that of control animals fed like Cow 51, February 17 to March 10 (Table III). So far, about a dozen experiments and controls have been carried through altogether, and the results indicate that the cows on the experimental feeding gain weight and improve in condition at least as satisfactorily as the controls and that their milk yield in the next succeeding lactation is decidedly larger.

We do not consider the results sufficiently numerous as yet to be final, and we are carrying out further experiments of the same sort. But, in the meantime, we wished to study the effects of the experimental feeding on calcium and phosphorus assimilation, and the experiments to be reported in this article have been planned with that end in view.

This made it possible to study the effects of feeding phosphate on the urinary and fecal excretion of phosphorus. We have previously shown that feeding phosphate tends to increase the concentration of phosphorus in the blood.⁵ It seemed worth while, therefore, to take a certain number of blood samples during the course of the balance experiments and to study the triple relationship between phosphorus in the rations, in the blood, and in the urine.

General Plan of Experiments.

Two healthy, grade Holstein cows were selected, each of which had been dry for about a month. Each had been fed for some time previous to the beginning of the experiment on the same ration that she was to have during the first part of the experiment. Both were in the last third of pregnancy. One, No. 51, was due to calve on April 17, 1919, 59 days after the beginning of the experiment, the other, No. 63, on May 4, 1919, 76 days after the beginning of the experiment. Their weights are given in Table I.

⁵ Meigs, E. B., Blatherwick, N. R., and Cary, C. A., *J. Biol. Chem.*, 1919, xxxvii, 45.

On February 17, 1919, the cows were brought into the stalls in which the experiment was to be carried out. These stalls, in the basement of the laboratory building, were built of wood. Their construction was in general similar to that to which the cows were accustomed. They were provided with mangers so constructed as to prevent effectively the scattering of the rations, and with beds made of several layers of sacking. The cows were held in stanchions like those to which they were accustomed. The temperature in the experiment room ranged from 10–18°C.

The urine and feces were collected in essentially the same manner as in Forbes'¹ experiments. Three men were employed, each of whom remained behind the cows for 8 hours out of the 24, and were provided with shovels and large, galvanized iron dippers in which to catch the feces and urine, respectively, before they reached the ground. In addition, a long, galvanized iron pan was placed behind each cow to catch any of the excreta that might accidentally fall. The feces caught in the shovels were transferred to covered, galvanized iron garbage cans, and the urine caught in the dippers was transferred to glass carboys. The excreta which fell accidentally were placed in separate receptacles and weighed. The total amount, however, throughout the course of the experiments was so small that no conceivable departure of its composition from the average could have had any perceptible effect on the results. It was therefore simply brought into the calculation as a part of the daily amount of excreta voided, but was not separately analyzed.

The experimental day began and ended at 10 a.m. At this time the urine and feces collected in the previous 24 hours were weighed and aliquot samples of each were set aside. As an aliquot from the feces we took $\frac{1}{50}$ of the total amount voided in the 24 hours and added a small amount of chloroform as a preservative. From the urine we took two aliquots in each case, one for the nitrogen determination, and the other for the calcium and phosphorus determinations. The first of these amounted to 20 cc. per pound of urine voided, and was preserved with a small amount of chloroform. The second amounted to 100 cc. per pound of urine voided. To this quantity enough strong HCl was added to make the resulting mixture distinctly acid to litmus after all the CO₂ had been driven off. The amount of HCl added was measured and recorded, and a small amount of chloroform was added.

The experimental period lasted in each case for 4 days. The aliquots obtained during this period were thoroughly mixed, and in this way representative samples were obtained for analysis. The results, however, are given as the daily average for each of the 4 day periods.

On February 17, 1919, a blood sample was obtained from each cow at about 8 a.m.; the cows were brought into the experimental stalls about 9 a.m., and their urine was collected for the next 18 hours. From February 18 until March 2, 1919, inclusive, the urine and feces were not collected, but otherwise the cows were kept under the same routine as during the collection periods. The rations given to each are shown in Table III.

The balance experiment began on March 3. About 8 a.m. on this date a second blood sample was obtained from each cow, and at 10 a.m. the collection of the urine and feces was begun. This was continued until 10 a.m. on March 11, the intervening 8 days being divided into two 4 day collection periods as described above. On the morning of March 11, a third blood sample was obtained from each cow, and the rations were reversed as shown in Table III. The period from March 11 to 20, inclusive, served as an intermediate period to accustom the cows to the new rations. The excreta were not collected.

On the morning of March 21, it was evident that No. 51 was going to abort, and she had to be discarded as a subject for the experiment. The abortion took place that evening. The calf was born dead, but it weighed about 30 kilos and was well formed for a calf born 4 weeks too early. A few weeks later No. 51 was tested for contagious abortion and reacted positively.

It was decided to carry the experiment on with No. 63 as originally planned, and to substitute for No. 51 another cow, No. 66, which had for 88 days previously been receiving the same alternated rations that were supplied to No. 51 from March 11 to 20. This cow was a grade Guernsey, and was neither pregnant nor milking, but it was thought that some further data could be obtained from her in regard to the effects of phosphate feeding on the concentration of phosphorus in the blood and the elimination of phosphorus and calcium in the urine.

At 7.30 on the morning of March 21, therefore, blood samples were obtained from Nos. 63 and 66 and at 10 a.m. the collection

of urine and feces was started. It was continued as before for two 4 day periods. At the end of the second one, blood samples were again taken and the experiment was concluded.

No. 63 gave birth to a normal calf, which weighed 31.4 kilos, on the morning of April 25, 1919.

The cows were, of course, closely watched for any abnormalities of appetite or general behavior. No. 51 showed no outward sign of disturbance by the experimental routine at any time, except that she drank less water during the collection periods than during the intermediate period (Table II).

No. 63, on the other hand, gave signs of being disturbed by various parts of the procedure. During the preliminary period (February 17 to March 2), she refused a part of her ration, although she had eaten it well for the entire previous 2 weeks in the general barn; her silage had to be reduced. She consumed the reduced ration for a day or two, but began to refuse some of it again as soon as the collection of urine and feces began. During the first 60 hours of the first collection period, she did not lie down in her stall, probably on account of abrasions which had developed on her hips and shoulders, and toward the end of this 60 hours she became obviously extremely nervous and uncomfortable. The difficulty was overcome by providing her with sacks filled with straw for a bed.⁵ Like No. 51, she drank less water in the collection periods than in the intermediate period. She also consistently refused some of her hay and silage in the collection periods in spite of the fact that her ration had been cut down. During the intermediate period, March 11 to 20, she refused only very small portions of her feed (Table IV).

No. 66, March 21 to 28, suffered, of course, from the double disturbance of new surroundings and collection of urine and feces. Her appetite was not much affected. She ate her rations, except for the stems of the hay and the cobs in the silage, but she drank very little water, and was obviously nervous under the experimental routine. She would start when anyone went near her or touched her, and would often begin the act of urination, and then discontinue it when the attendant approached her.

⁵ All cows were provided with beds of this sort from the beginning of the intermediate period, Mar. 11 to 20.

Analytical Methods.

In undertaking our analyses of the materials fed to the cattle, we realized keenly the difficulties which might lead us into error. The errors to be expected may be summed up under two heads; those due to the fact that all the feeding materials contain a considerable and more or less inconstant percentage of water, and those due to the difficulty of obtaining representative samples for analysis—particularly from such materials as corn silage and alfalfa hay. Our preliminary experience showed us that these difficulties are very real.

They are to be avoided by grinding large samples, by thorough mixing of the ground material, and by making sufficiently numerous moisture determinations. The process of grinding often produces very considerable changes in water content, which must be adequately controlled.

We evolved a procedure which gave satisfactory results, but we do not think it necessary to give it in detail. Its detailed description would occupy a great deal of space, and the precautions are such as would occur to anyone seriously interested in the subject. We prepared enough hay and grain at the beginning to last through the experiment; but with the silage we found it advantageous to take out aliquot samples for analysis from each feed. The aliquots for each collection period were thoroughly mixed and analyzed separately from those of the other periods, and in our tables, therefore, the composition of the silage fed is given for each period separately. The composition of the various feeds is given in Table V; and the composition of the feed refused, in Table VI. In a footnote to Table IV are given details concerning the manner in which the feed refused was handled.

The analytical methods used, were, in general, those described in our previous article.⁵ Some modifications have, however, been introduced as indicated below.

For calcium determinations we ashed some of our samples of feces and some of our samples of hay in platinum crucibles over a free flame or in an electric furnace, instead of with nitric and sulfuric acids. We found it most convenient to determine calcium in urine directly without ashing, as suggested by McCrudden.⁷

⁷ McCrudden, F. H., *J. Biol. Chem.*, 1911-12, x, 199.

In some calcium determinations, also, in material ashed with nitric and sulfuric acids, we omitted the preliminary precipitation of the calcium as sulfate, our new procedure being as follows:

The acid ash is boiled with about 25 cc. of water as usual and then made up to approximately 75 cc. with water. One drop of 0.006 per cent phenolsulfonephthalein is added and 28 per cent NH_3 until the color changes through yellow to pink. The mixture is cooled and 10 per cent HCl is added drop by drop until the color changes back to clear yellow; 10 cc. of 0.5 \times HCl and 10 cc. of 1.75 per cent $\text{H}_2\text{C}_2\text{O}_4$ are then added; the mixture is heated to boiling; 20 cc. of saturated $(\text{NH}_4)_2\text{C}_2\text{O}_4$ solution are added; and the mixture is kept gently boiling until the precipitate becomes coarse (15 to 30 minutes). It is then cooled to 50° or below, 10 cc. of 10 per cent $\text{NaC}_2\text{H}_3\text{O}_2$ are added, and the calcium in the oxalate precipitate is determined according to the procedure given in our earlier article.

With these exceptions our analyses were carried out exactly as described in our earlier article; and, in the cases where we departed from the old procedure, we carried out parallel analyses on the same samples of material and satisfied ourselves that the two methods gave the same results. We determined the moisture in our material by drying to constant weight at a temperature between 103 and 107° .

We had a good deal of difficulty with the urine. Cow's urine often contains so little calcium and phosphorus that large samples must be taken if accurate results are to be obtained. To evaporate these large samples and ash the residues over a flame is very tedious and troublesome, while, if the samples are ashed with acid mixture, much difficulty is encountered on account of the high content of hippuric acid which changes to benzoic acid during the ashing. After trying various procedures we found that it was most satisfactory to determine calcium without ashing as described above, and to determine phosphorus in samples which had been ashed with sulfuric and nitric acids. The aliquot samples of urine were immediately mixed with enough hydrochloric acid to drive off all the carbonate and render them distinctly acid to litmus, and this treatment brought about the precipitation of a large proportion of the hippuric acid. Calcium and phosphorus were determined after filtering this off. For the determination of nitrogen,

of course, it was necessary to set aside other aliquots not acidified and preserved only with a small amount of chloroform.

The blood samples were treated and analyzed as described in our previous article, except that in some cases a change was made in the procedure for calcium, as described above.

In regard to the size of the samples and the accuracy of the determinations in the case of the blood, the remarks given in our earlier article apply also to this investigation. The figures given in our tables for the composition of blood and plasma are the averages of duplicates which generally agreed with one another within 5 per cent.⁸ The same remark applies also to our figures for the composition of the urine. For the feeds and feces we were able to take optimum samples, and the duplicates generally agreed more closely.

The results of our experiments are given in Tables I to XII at the end of the article.

Calcium and Phosphorus Metabolism in Balance Experiments.

Our results show a peculiar relation between calcium and phosphorus assimilation which seems to us to call for very careful consideration. In every period except that of March 3 to 6, in the case of No. 51, phosphorus was assimilated in larger absolute quantity than calcium. The phosphorus balances were positive throughout, while two out of the eight calcium balances were negative.

In six out of the eight periods, we were dealing with cows which were carrying calves, and at or beyond the 7th month of pregnancy. It is possible to form an approximate estimate of the rapidity with which calcium and phosphorus are assimilated by the embryo calf in the last 2 months of its intrauterine existence. A calf, according to Forbes and Keith,⁹ contains about 1.65 per cent CaO and 1.53 per cent P₂O₅ in its body, and a new-born calf weighs

⁸ The difference obtained by subtracting one figure from the other was 5 per cent or less of the larger.

⁹ Forbes, E. B., and Keith, M. H., *Ohio Agric. Exp. Station, Techn. Bull.* 5, 1914, 106.

about 35 kilos. A new-born calf, therefore, would have about 413 gm. of calcium and 234 gm. of phosphorus in its body.

Forbes and Keith (page 110)⁹ give the weights and the CaO and P₂O₅ contents of human embryos at various stages. As the human and bovine gestation periods are very nearly the same, the figures given may be taken as an approximate representation of the progress of things in the case of the calf. The human embryo at 7 months weighs about one-third of what it weighs at term, and its body contains about two-thirds the percentage of calcium and phosphorus that is contained in that of the new-born infant. The 7 months embryo, therefore, would contain about two-ninths of the absolute quantities of calcium and phosphorus contained in the new-born infant or calf. $\frac{2}{9}$ of 413 is approximately 92, and $\frac{2}{9}$ of 234 is 52. In the last 60 days of intrauterine life, therefore, the embryo calf must assimilate about 321 gm. of calcium or 5.3 gm. a day, and about 182 gm. of phosphorus, or 3.0 gm. a day. These figures are of course only rough approximations, but they are quite accurate enough for our purposes.

Reference to Table X shows that the daily phosphorus assimilation of Cows 51 and 63 was sometimes above and sometimes below 3.0. The average for the six periods in which these cows were studied is 3.33, which corresponds satisfactorily with the calculated figure.

The results with regard to calcium metabolism are strikingly different. The calcium assimilation of our pregnant cows was always well below 5.3, the nearest figure to this being 3.5 for No. 51, March 3 to 6. The average daily calcium assimilation for our pregnant cows was only 1.44 gm. This means that if the calves were growing at all as they should during the periods of the balance experiments their mothers must have been transferring considerable quantities of calcium from their own bones to those of their offspring.

One's first idea is that our rations must have been markedly deficient in calcium. We do not think that this was the case. We fed alfalfa hay, and the rations contained from 30 to 40 gm. of calcium daily. This quantity is generally considered liberal; and if our rations had been markedly deficient in calcium, the bad effects should have shown themselves in imperfectly formed calves and in reduced subsequent milk yield; because both cows were on

approximately the same rations they received during the collection periods for from 7 to 11 weeks before calving. None of these bad effects showed itself. It is true that No. 51 aborted, but there was much contagious abortion in the herd at the time, and she was shown to have the disease. The premature calf was large and well formed for a calf born nearly 4 weeks ahead of time, and had certainly died only a few hours before its birth. No. 63 gave birth to a fair sized and perfectly normal calf at about the right time. Both cows have given much more milk in the lactation periods succeeding the experiments than they had ever given before.

We think that the true explanation of our results on calcium and phosphorus assimilation is quite different from that which has been suggested; and, in order to bring out certain important aspects of the subject, we wish to call attention to the proportions of calcium and phosphorus contained in the bodies of certain mammals, and to the results which have been obtained in balance experiments on the same species of mammals in the past.

The ratio $\frac{\text{Ca}}{\text{P}}$ contained in the whole bodies of mammals is fairly constant, and somewhat higher in mature than in new-born animals. For mature cattle and sheep this ratio is about 1.9:1; for mature pigs about 1.6:1.¹⁰ Growing cattle and sheep must therefore, on the average, assimilate at least 1.9 parts by weight of Ca for 1 part by weight of P; growing pigs must assimilate about 1.6 parts of Ca for 1 part of P. The figures obtained in balance experiments carried out in the past deviate largely from these ratios and almost universally in the same direction.

We have made a representative study of the balance experiments carried out in the last 60 years, selecting those which included work on the calcium and phosphorus balances of healthy growing animals fed on normal or nearly normal rations.^{11, 12, 13} In these

¹⁰ Forbes and Keith.⁹ These ratios represent absolute weights, not equivalents.

¹¹ Lehmann, J., *Landw. Ver.-Stat.*, 1859, i, 68. von Gohren, T., *ibid.*, 1861, iii, 161. Soxhlet, *Erste Bericht über Arbeiten der landwirtschaftlichen-chemischen Versuchs-Station in Wien*, 1870-71, 101. Weiske, H., *J. Landw.*, 1873, xxi, 139. Hofmeister, V., *Landw. Ver.-Stat.*, 1873, xvi, 126. Köhler, A., Honcamp, F., Just, M., Volhard, J., Popp, M., and Zahn.

twelve researches are included the results of 136 separate experiments. In all but eighteen of these the ratio $\frac{\text{Ca assimilation}}{\text{P assimilation}}$ is less than 1.9 for the cattle and sheep, and less than 1.6 for the pigs.

The unanimity with which balance experiments on growing animals show a deficiency in calcium intake as compared to phosphorus intake becomes still more impressive if the contrary cases are examined critically. Two of these are from the work of Hofmeister. In the same article that author gives figures for mature sheep which are plainly incorrect. The figures for the mature and growing sheep were obtained by the same methods, and it is justifiable, therefore, to doubt the adequacy of the experimental methods. A satisfactory criticism of Hofmeister's work is given by Neumann.¹³

Six of the other cases in which the calcium assimilation was not deficient occur in the work of Forbes, Beegle, Fritz, and Mensching on pigs. The pigs in question had been for 51 days on rations which contained from five to ten times as much phosphorus as calcium. Their calcium and phosphorus assimilation was followed during this period, and the calcium assimilation was always observed to be markedly deficient with respect to the phosphorus. At the end of the 51 days they were changed to a "meat meal" or skim milk ration with a comparatively high calcium content, and it is under these circumstances that the $\frac{\text{Ca}}{\text{P}}$ ratio becomes a little larger than the expected one.

Four more cases in which the calcium assimilation was not deficient with respect to the phosphorus are those of Sawyer, Baumann, and Stevens in their work on human beings. In this work, however, the phosphorus balances were negative throughout; and the results, therefore, cannot be taken as representing anything approaching average conditions in growing human beings.

O., *Landw. Ver.-Stat.*, 1904-05, lxi, 451. Köhler, A., Honcamp, F., and Eisenkolbe, P., *ibid.*, 1907, lxxv, 349. Forbes, E. B., with collaborators, *Ohio Agric. Exp. Station, Techn. Bull.* 6, 1915. Forbes, E. B., Beegle, F. M., Fritz, C. M., and Mensching, J. E., *Ohio Agric. Exp. Station, Bull.* 271, 1914. Sawyer, M., Baumann, L., and Stevens, F., *J. Biol. Chem.*, 1918, xxxiii, 103.

¹² Weiske, H., *Landw. Jahrb.*, 1880, ix, 205.

¹³ Neumann, J., *J. Landw.*, 1893, xli, 343.

Out of the 136 individual experiments on growing animals, therefore, the calcium intake is deficient with respect to the phosphorus in 118; and of the eighteen which do not exhibit this peculiarity, two are open to grave suspicion of experimental error, six were carried out under conditions which quite unusually favored an excessive calcium intake, and four are of such nature that they cannot be regarded as representing growth at all.

Of the remaining six, two occur in the work of Weiske. Lambs were kept on a fairly uniform ration between the ages of 4 and 14 months, and 8 day balance periods were run at intervals of about a month. If the conditions under which animals are put in balance experiments do not disturb calcium and phosphorus metabolism, this procedure ought certainly to give a representative picture of the manner in which these elements are assimilated between the ages of 4 and 14 months, in lambs.

The whole experiment falls readily into two main periods. The first of these lasted a little more than 2 months, and in it the ratio $\frac{\text{Ca assimilation}}{\text{P assimilation}}$ was a little larger than is to be expected. The second period includes the last $7\frac{1}{2}$ months of the experiment, during which the ratio $\frac{\text{Ca assimilation}}{\text{P assimilation}}$ was decidedly smaller than the expected one. The markedly low $\frac{\text{Ca}}{\text{P}}$ ratios during the last $7\frac{1}{2}$ months much more than compensate for the slightly high ones during the first $2\frac{1}{2}$ months; so that, if the figures were representative, the lambs' bodies at the end of the experiment would have contained much less calcium in proportion to phosphorus than is normal.

In view of the many chances of error to which balance experiments are subject, it seems to us remarkable that they should agree so nearly universally in any particular; and we think that the results point unmistakably to the conclusion that calcium assimilation is interfered with by the conditions to which animals have been subjected in these experiments.

We have studied with interest the experiments in which calcium and phosphorus metabolism have been followed in mature animals not subject to any special demand for these elements, and in mature milking animals. We do not think it worth while to give

any detailed discussion of the first of these classes of experiments. As was to have been expected, both calcium and phosphorus balances are sometimes positive and sometimes negative, but the figures are usually small, and there is no very marked general tendency for either element to be gained or lost faster than the other. It does not seem to us that these results have any bearing, one way or the other, on the view which we have gained from our study of the results on growing animals. In mature animals which are neither pregnant nor lactating, the assimilative requirements for calcium and phosphorus are small in comparison to those met by the young animal and by the pregnant or lactating female; and it is not to be expected that the mildly unusual conditions which accompany a well conducted balance experiment could show themselves very definitely as a reduction in calcium assimilation.^{12, 14} But the results which have been obtained from milking animals seem to us to lend strong support to the view that the conditions of balance experiments interfere with the absorption¹⁵ of calcium and to be incomprehensible on any other basis.

We are familiar with experiments by three independent sets of investigators, in which the calcium and phosphorus balances were followed in milking cows.^{1, 16} In two of these investigations, namely, those of Anger and Forbes, most of the cows were fed on what might be called normal average rations, and the results can be conveniently considered together. Both calcium and phosphorus balances were generally negative, and the authors conclude that it is usual for milking cows to be taking these elements from their bodies in order to put them into the milk.

It is natural to suppose that the calcium and phosphorus lost by the cows in Anger's and in Forbes' experiments came from the bones. The calcium must have come chiefly from the bones, for

¹² Experiments of this kind have been carried out by Hofmeister, V., *Landw. Ver.-Stat.*, 1873, xvi, 343. Wellman, O., *Arch. ges. Physiol.*, 1908, cxxi, 508. Sherman, H. C., Gillett, L. H., and Pope, H. M., *J. Biol. Chem.*, 1918, xxxiv, 373. Sherman, H. C., Wheeler, L., and Yates, A. B., *ibid.*, 383.

¹³ We think it better to use the word "absorption" for milking animals, and to reserve the term "assimilation" for the cases where the absorbed material is actually retained in the body.

¹⁴ Anger, A., Inaugural dissertation, Bonn, 1898. Hart, E. B., McCollum, E. V., and Humphrey, G. C., *Am. J. Physiol.*, 1909, xxiv, 86.

the calcium content of the mammalian soft tissues is so small that the subjects of these experiments often lost in 3 or 4 days more calcium than is contained in the whole body of a cow outside of her bones and teeth.

The $\frac{\text{Ca}}{\text{P}}$ ratio in bone is about 2.15. But the average daily calcium loss divided by the average daily phosphorus loss in Anger's and in Forbes' experiments deviates largely from this ratio. In Anger's experiments it is 12.23; and in the three sets of experiments reported by Forbes¹ it is 9.07, 213.00, and 3.62 respectively. The calcium loss is largely in excess of what it should be if the process is simply a wasting of bone tissue.

The results are very difficult to reconcile with our results, which appear to show that pregnant cows readily absorb enough phosphorus from their food to supply the growing embryo, but that they are usually compelled to supply calcium to their offspring from their own bones. As many cows are always either pregnant or milking, or both, through a large proportion of their lives, these results taken together would seem to point to the impossible conclusion that the normal milch cow is constantly changing the $\frac{\text{Ca}}{\text{P}}$ ratio of her body in the direction of more phosphorus and less calcium throughout the whole period of her useful life.

The experiment of Hart, McCollum, and Humphrey has been included in this discussion because of the very surprising nature of the conclusions to be drawn from it on the supposition that the calcium and phosphorus metabolism of cows is not disturbed by the collection of their excreta. A single milking cow was kept for 110 consecutive days on known rations low in calcium, and the excreta were collected during 25 days of this period so that the calcium and phosphorus balances could be followed. If it is supposed that the results obtained in the collection periods can be applied to the whole 110 days, it would follow that during this period the cow lost about 25 per cent of all the calcium contained in her body and remained very nearly in phosphorus equilibrium. We should have to suppose, therefore, either that the composition of her bones was profoundly altered, or that 25 per cent of the phosphorus lost from the bones along with the calcium was stored in the soft tissues.

Weiske¹⁷ has studied the bones of a milking goat which was kept for 50 days on a low calcium ration. His results show that the change in the $\frac{\text{Ca}}{\text{P}}$ ratio of the bones produced by this treatment is negligible. And Hart, McCollum, and Fuller¹⁸ have furnished excellent evidence against the possibility of producing any considerable changes in the phosphorus content of the mammalian soft tissues. It seems to us, therefore, that the experiment of Hart, McCollum, and Humphrey¹⁶ can best be interpreted by supposing that their figures for calcium and phosphorus metabolism during the collection periods are not representative for the whole 110 days of the experiment, and that in the intermediate periods the cow largely made up the marked calcium deficiency produced during the collection periods.

The situation may be summed up as follows. There is an apparent contradiction between the results obtained regarding the calcium and phosphorus balances of growing animals and what is known regarding the calcium and phosphorus content of the bodies of the same species of animals. There is a similar contradiction between results that have been obtained regarding the calcium and phosphorus balances of milking animals, and results obtained from studying the bones of milking animals. Finally, the results which have been obtained regarding the calcium and phosphorus balances of milking cows appear to be irreconcilable with those which have been obtained regarding those balances in cows toward the end of pregnancy. All these difficulties would be removed by making the assumption that the conditions to which animals have been subjected in balance experiments are likely to interfere with calcium absorption.

We are the more ready to make this assumption, because it is in full agreement with recent striking scientific evidence in regard to the effects of emotional disturbance on the digestive processes. It has been shown by numerous investigators that comparatively mild disagreeable stimuli are capable of producing disturbances in the nervous system which may inhibit the secretion of the

¹⁷ Weiske, H., *Z. Biol.*, 1871, vii, 179, 333.

¹⁸ Hart, E. B., McCollum, E. V., and Fuller, J. G., *Univ. Wisconsin Agric. Exp. Station, Research Bull. 1*, 1909.

digestive juices and the movements of the alimentary tract for considerable periods. A good review of the subject with references to the literature is given by Cannon.¹⁹

Our Own Evidence in Regard to Disturbance and Calcium Assimilation.

Throughout our own experiments, two 4 day collection periods followed each other without any change at all in the experimental routine; and in each case, except that of No. 66, the two collection periods followed a preliminary 10 day period without any change in routine except the introduction of the collection of urine and feces. If the collection of urine and feces produced no disturbance in metabolism, the metabolic behavior of the cows should have been the same in each case in the first of the 4 day collection periods as in the immediately following one; and the same, as far as it was followed, in the preliminary periods as in the collection periods. This was not the case.

It has been our experience that any slight change in the surroundings of a cow or disturbance of her habits is likely to cause a reduction in the amount of water which she will drink. The water taken by Nos. 51 and 63 in the collection periods, March 3 to 10, in the intermediate period, March 11 to 20, and in the collection periods, March 21 to 28, was followed (Table II). Both cows took decidedly more water in the intermediate period than in any of the collection periods.

Much more evidence pointing in the same direction can be obtained by comparing the metabolic processes of the cows in the first collection periods and in the immediately succeeding ones. But, before discussing this evidence, it must be pointed out that certain accidents occurred in the course of the experiments which must be taken into account in interpreting the results.

No. 63 developed abrasions during the preliminary period, February 17 to March 2, and refused to lie down during the first 60 hours of the collection period, March 3 to 6. On the evening of March 5, she was provided with a softer bed, and there was no trouble after that. Further, No. 51 could not be used in

¹⁹ Cannon, W. B., *Bodily changes in pain, hunger, fear and rage*, New York and London, 1915, Chapter I, 1-20.

the experiment after March 21; No. 66 was unexpectedly substituted for her, and went through the two collection periods, March 21 to 24 and 25 to 28, without any preliminary period in the experimental surroundings. In her case, therefore, the additional factor of new surroundings was added to that of the mere collection of urine and feces.

Table II shows that No. 51 drank more water from March 3 to 6 than from March 7 to 10; and No. 63, more from March 21 to 24 than from March 25 to 28. These results suggest that the collection of urine and feces produced more disturbance during the second of the two consecutive 4 day collection periods than during the first one. It is true that No. 63 drank more water from March 7 to 10 than from March 3 to 6; and No. 66, more from March 25 to 28 than from March 21 to 24. But neither of these results is really out of harmony with the suggestion indicated above. In the case of No. 63 an additional disturbing factor was introduced during the period March 3 to 6 by the fact that the abrasions which had developed on her hips and shoulders prevented her from lying down. The case of No. 66, on the other hand, may well be discarded from the discussion, for, in addition to the fact that she had had no preliminary period in the experimental stall, the water which she drank on March 21 could not be determined.

The manner in which our cows took their water, therefore, suggests that a disturbance was produced by the collection of their urine and feces, which was cumulative for a considerable period and produced more marked effects in the second 4 days of collection than in the first 4. This suggestion is strongly confirmed by a study of the nitrogen, calcium, and phosphorus balances given in Table X. In every case, except that of No. 63, March 3 to 10, where the exceptional disturbance was accidentally introduced in the first 4 days, the assimilation of all three elements occurred more rapidly in the first of the 4 day collection periods than in the immediately succeeding one. In the case of No. 63, March 3 to 10, the relations are reversed for all three elements.

It seems surprising perhaps at first sight that assimilation was generally better in the first than in the second 4 day collection period. It might have been expected that the cows would be more accustomed to the collection of their excreta in the second period, and that their assimilative processes would therefore

have been more nearly normal. But we can see no escape from the facts, and the circumstance that the relations are reversed in the case of No. 63, March 3 to 10, seems to us decidedly to strengthen the case. Steenbock and Hart²⁰ have reported results which show how persistent may be the tendency toward a negative calcium balance under the conditions of a balance experiment, and how this tendency may be overcome by a short period of relief from these conditions.

Our results are in agreement with those of past experiments in showing that the assimilation of calcium is more quickly and more profoundly affected by the experimental procedure than that of either phosphorus or nitrogen. It has already been pointed out that the phosphorus assimilation in Nos. 51 and 63 was about enough on the average to supply the phosphorus needed by their growing unborn calves, but that the calcium assimilation was never sufficient for this in any single period. It must be pointed out in addition that the fluctuations in calcium assimilation as between the first and second 4 day periods were greater both relatively and absolutely in every case than the similar fluctuations for either phosphorus or nitrogen.

The Effects on Calcium, Phosphorus, and Nitrogen Assimilation of Feeding Sodium Phosphate and Alternating the Grain and Hay Rations.

For convenience the rations fed to No. 63, March 3 to 10, and to No. 66, March 21 to 28, will be called the "experimental rations," while the rations fed to No. 51, March 3 to 10, and to No. 63, March 21 to 28, will be called the "control rations."

The results indicate that phosphorus assimilation is favored by feeding the experimental rations. Although it is clear from certain aspects of the results that phosphorus assimilation is interfered with by disturbance, and that the cows on the experimental rations were decidedly more disturbed than those on the control rations, nevertheless, the cows fed the experimental rations assimilated phosphorus uniformly more rapidly than the controls.

In regard to calcium assimilation the results are not so consistent but on the whole they favor the view that this process also occurs

²⁰ Steenbock, H., and Hart, E. B., *J. Biol. Chem.*, 1913, xiv, 59.

more rapidly in the cows fed the experimental rations. It is true that the most rapid calcium assimilation occurs in the case of No. 51, March 3 to 10, on the control ration. But this cow was decidedly less disturbed by the experimental conditions than any of the others, and she was, in addition, the largest, the most robust, and the best milker of the three. All the other results are consistent in indicating that calcium assimilation occurs more rapidly during the experimental feeding. No. 63, for instance, was assimilating calcium more rapidly during the experimental period, March 3 to 10, than during the control period, March 21 to 28, although she was much more disturbed by the experimental procedure during the first than during the second of these periods; and even No. 66, though she was not carrying a calf, and was evidently much upset by the double disturbance of new surroundings and collection of her urine and feces during the period March 21 to 28, nevertheless, assimilated calcium more rapidly on the experimental rations during this period than did No. 63 during the same period on the control rations.

The results appear to indicate that the experimental feeding is unfavorable to nitrogen assimilation. But we have kept cows for long periods on the experimental rations, and have found that they gained weight at least as well and remained in at least as good general condition as others on the control rations (page 471). We do not think, therefore, that the experimental rations are unfavorable to nitrogen assimilation, and we are inclined to attribute the reduced nitrogen assimilation of No. 63 on these rations to the facts that, when on these rations, she was at an earlier stage of pregnancy and more disturbed by the experimental procedure. That No. 66 should have assimilated nitrogen as fast as the other two cows is not to be expected, as she was not carrying a calf; and the fact that her nitrogen balance was positive at all indicates that the experimental feeding is not unfavorable to nitrogen assimilation.

Calcium and Phosphorus in Food, Blood, and Urine.

In Table XII we have brought together our results on urine and on blood plasma collected approximately simultaneously. The results there given indicate that there is a connection between

the phosphate feeding, the concentration of inorganic phosphorus in the blood plasma, and the amount of phosphorus excreted in the urine. No. 63, for instance, during the period March 3 to 10, when she was fed phosphate, had an average concentration of about 0.0063 per cent phosphorus in her plasma and was excreting about 0.88 gm. daily in her urine. During the period March 21 to 28, when she received no phosphate, her plasma phosphorus dropped to 0.0052 per cent and her daily urinary phosphorus excretion to about one-ninth of what it was previously. No. 51, March 3 to 10, received no phosphate, had a plasma phosphorus of about 0.0056 per cent, and was excreting less than 0.1 gm. of phosphorus in her daily urine.

Closer examination of the figures, however, shows that the urinary excretion of phosphorus does not depend entirely on the concentration of inorganic phosphorus in the plasma. No. 66, March 21 to 28, for instance, had a decidedly higher plasma phosphorus than either No. 51, March 3 to 10, or No. 63, March 21 to 28, and was, nevertheless, excreting less phosphorus in her daily urine. And if the figures given for No. 63 for February 17, March 3, and March 11 are examined, it will be found that there is an inverse relation between the plasma phosphorus and the daily urinary phosphorus excretion.

We are inclined to suspect that these disturbances of the relation between the concentrations of plasma phosphorus and urinary phosphorus were connected with differences in the acid-base equilibrium of our animals; but, in the present inadequate state of our knowledge, we do not think it worth while to discuss this matter further.

We obtained wide variations in the amount of calcium excreted in the urine, in spite of the fact that all our cows at all times received about the same amount of calcium in their rations, and that there was little variation in the concentration of calcium in their blood plasma. In looking for an explanation for these variations, we have been struck by the fact that there is an inverse relation between the concentrations of urinary calcium and phosphorus in our experiments, and we think that this circumstance has some significance. Bertram⁴ and Rüdél²¹ have reported

²¹ Rüdél, G., *Arch. Exp. Path. u. Pharmacol.*, 1894, xxxiii, 79.

results which indicate a tendency toward inverse relationship between the calcium and phosphorus of mammalian urine, and it is of course impossible that an alkaline fluid such as average cow's urine could hold much calcium and phosphate in solution at the same time.

But we do not think it worth while to discuss the mechanism of these relationships at the present time. The chief value of the results which we are considering lies in the demonstration that the amount of calcium excreted in the urine is largely independent of the concentration of calcium in the blood plasma.

SUMMARY.

1. The separate collection of urine and feces by attendants, as practiced in balance experiments on cows, produces a nervous disturbance in the animals which interferes markedly with the assimilation of calcium, and, to a less degree, with that of nitrogen and phosphorus. A critical examination of the results of balance experiments carried out in the past indicates that, in the great majority of instances, the experimental procedure has interfered with calcium assimilation.

2. The assimilation of phosphorus by pregnant cows, and probably that of calcium also, is favored by adding disodium phosphate to the grain and feeding the grain and hay of the ration on alternate days.

3. The urinary excretion of phosphorus is markedly influenced by the concentration of inorganic phosphorus in the blood plasma. But our results show that it is influenced also by another factor, which may be connected with the acid-base equilibrium of the body.

4. In our experiments there has been an inverse relation between the amounts of calcium and phosphorus excreted in the urine. But we have no doubt that this relation is easily disturbed by other influences, particularly the relation between the acids and bases of the ration.

TABLE I.
Weights of Cows.

Date.	No. 51.	No. 63.	Date.	No. 51.	No. 63.
<i>1919</i>	<i>kg.</i>	<i>kg.</i>	<i>1919</i>	<i>kg.</i>	<i>kg.</i>
Feb. 14	529.5	478.6	Mar. 18	540.9	462.3
" 15	515.5	481.4	" 19	542.6	461.4
" 16	514.1	479.1	" 20	550.0	461.4
Average.....	519.7	479.7	544.5	461.7
Feb. 26	524.1	465.5			
" 27	529.1	465.9			
" 28	525.9	467.7			
Average.....	526.4	466.4			
				No. 66.	
Mar. 11	540.5	461.4	Mar. 29	397.7	481.8
" 12	542.7	460.0	" 30	408.6	476.8
" 13	538.6	461.4	" 31	401.8	473.6
Average.....	540.6	460.9	402.7	477.4

TABLE II.
Water Drunk by Cows.*

Date.	No. 51.	No. 63.	Date.	No. 51.	No. 63.
1919	kg.	kg.	1919	kg.	kg.
Mar. 3	20.41	19.50	Mar. 19	26.62	20.41
" 4	16.19	5.10	" 20	21.63	20.01
" 5	20.95	12.22			
" 6	21.60	17.55			
Average.....	19.79	13.59	23.88	21.07
				No. 66.	
Mar. 7	16.92	20.13	Mar. 21	Undeter- mined.†	16.87
" 8	0.00	20.07	" 22	0.00	16.36
" 9	18.65	6.38	" 23	13.89	24.58
" 10	13.55	23.95	" 24	7.85	16.84
Average.....	12.28	17.63	7.25‡	18.66
Mar. 11	13.58	17.86	Mar. 25	18.82	9.07
" 12	31.35	18.09	" 26	16.78	27.47
" 13	27.07	23.22	" 27	13.15	15.88
" 14	21.94	20.04	" 28	12.02	17.97
" 15	26.11	24.55			
" 16	22.96	21.43			
" 17	26.42	25.46			
" 18	21.12	19.67			
Average.....	15.19	17.60

* The water supplied to the cows was tap water. Samples of it were analyzed for calcium and phosphorus, and it was found to contain 0.9 mg. of calcium per liter, and only a trace of phosphorus. The phosphorus content was certainly less than 0.005 mg. per liter. As none of the cows ever took as much as 30 liters of water in a day, the calcium and phosphorus which they got from the water may be disregarded in calculating the balances.

† No. 66 had free access to a water trough during the early morning of March 21, and in the afternoon she drank 10.55 kg. of water.

‡ Average calculated from water drunk during last 3 days of test.

TABLE III.
 Feed Offered to Cows.*

Date.	No. 51.			No. 63.		
	Grain without phosphate.†	Alfalfa hay.	Corn silage.	Grain with phosphate.‡	Alfalfa hay.	Corn silage.
1919	<i>gm.</i>	<i>gm.</i>	<i>gm.</i>	<i>gm.</i>	<i>gm.</i>	<i>gm.</i>
Feb. 17	1,361	1,814	13,608	0	3,628	13,608
“ 18	1,361	1,814	13,608	2,722	0	13,608
“ 19	1,361	1,814	13,608	0	3,628	13,608
“ 20	1,361	1,814	13,608	2,722	0	13,608
	Same till Mar. 1.			Same till Mar. 1.		
Mar. 1	1,361	1,814	13,608	0	3,628	5,413
“ 2	1,361	1,814	13,608	2,722	0	10,886
“ 3	1,361	1,814	13,608	0	3,628	10,886
	Same till Mar. 11.			Same till Mar. 11.		
Date.	Grain with phosphate.‡	Alfalfa hay.	Corn silage.	Grain without phosphate.†	Alfalfa hay.	Corn silage.
1919	<i>gm.</i>	<i>gm.</i>	<i>gm.</i>	<i>gm.</i>	<i>gm.</i>	<i>gm.</i>
Mar. 11	0	3,628	13,608	1,361	1,814	10,886
“ 12	2,722	0	13,608	1,361	1,814	10,886
	Same till Mar. 21.			Same till Mar. 21.		
Date.	No. 66.			No. 63.		
Date.	Grain with phosphate.‡	Alfalfa hay.	Corn silage.	Grain without phosphate.†	Alfalfa hay.	Corn silage.
1919	<i>gm.</i>	<i>gm.</i>	<i>gm.</i>	<i>gm.</i>	<i>gm.</i>	<i>gm.</i>
Mar. 21	0	3,628	13,608	1,361	1,814	10,886
“ 22	2,722	0	10,886	1,361	1,814	10,886
“ 23	0	3,628	10,886	1,361	1,814	10,886
	Same till Mar. 29.			Same till Mar. 29.		

* From Jan. 31 to Feb. 16 inclusive No. 51 had received the same ration as that given Feb. 17 to Mar. 11; No. 63, from Feb. 3 to 16, the same as from Feb. 17 to 28; No. 66, from Dec. 18, 1917, to Mar. 20, 1919, inclusive, the same as from Mar. 21 to 28, except that throughout the earlier period her daily silage was 13,608. All three cows had eaten satisfactorily the rations they received before being put on the experiment.

† Grain without phosphate composed of 50 parts of corn and cob meal, 40 parts of wheat bran, 20 parts of cottonseed meal, and 1 part of NaCl.

‡ Grain with phosphate composed of 50 parts of corn and cob meal, 40 parts of wheat bran, 20 parts of cottonseed meal, 1 part of NaCl, and 10 parts of Na_2HPO_4 with about 9 molecules of water of crystallization.

TABLE IV.
*Feed Refused by Cows; Totals for Periods.**

Period.	No. 51.	No. 63.
<i>1919</i>		
Feb. 17-Mar. 2	0	Approximately 900 gm. of grain, 100 gm. of hay, 4,000 gm. of silage.
Mar. 3-6	0	6,237 gm. of a mixture of hay and silage.
" 7-10	0	Approximately 1,300 gm. of a mixture of hay and silage.
" 11-20	0	Negligible quantities; not weighed.
	No. 66.	No. 63.
Mar. 21-24	Approximately 3,000 gm. of pieces of cob and stem.	Approximately 300 gm. of a mixture of hay and silage.
" 25-28	Approximately 2,500 gm. of pieces of cob and stem.	Approximately 1,200 gm. of a mixture of hay and silage.

*The feed refused was, in most cases, dried without being weighed. There was no object in obtaining its moisture content as it had always lain for some time in the manger, and contained, therefore, a different amount of moisture from the feed originally offered. The dried refused feed was weighed and analyzed for nitrogen, calcium, and phosphorus (Table VI). The figures give a fairly accurate idea of the proportions of grain, hay, and silage contained in the various samples of feed refused.

TABLE V.
Composition of Materials Fed.

Feed.	Water.	Nitrogen.	Calcium.	Phosphorus.	
	<i>per cent</i>	<i>per cent</i>	<i>per cent</i>	<i>per cent</i>	
Grain with phosphate.....	17.59	2.1036	0.0659	1.4727	
“ without “	13.84	2.1837	0.0707	0.7007	
Hay.....	16.73	1.8754	1.3103	0.2138	
Silage {	Mar. 3-6.....	66.91	0.3951	0.1035	0.0733
	“ 7-10.....	69.21	0.3400	0.0926	0.0650
	“ 21-24.....	69.98	0.3321	0.1001	0.0671
	“ 25-28.....	67.45	0.3102	0.1037	0.0686

TABLE VI.
Nitrogen, Calcium, and Phosphorus in Feed Refused. Absolute Quantities of Elements in Daily Average Quantities of Feed Refused.

Cow No.	Period.	Nitrogen.	Calcium.	Phosphorus.
	<i>1919</i>	<i>gm.</i>	<i>gm.</i>	<i>gm.</i>
63	Mar. 3-6.....	8.99	3.4975	1.5328
	“ 7-10.....	2.38	1.0963	0.4866
	“ 21-24.....	0.69	0.3566	0.0991
	“ 25-28.....	2.75	1.4264	0.3962
66	Mar. 21-24.....	2.71	0.7559	0.6819
	“ 25-28.....	1.81	0.6218	0.5770

TABLE VII.
Absolute Quantities of Feces and Urine Voided during Collection Periods.

Date.	No. 51.		No. 63.		Date.	No. 66.		No. 63.	
	Feces.	Urine.	Feces.	Urine.		Feces.	Urine.	Feces.	Urine.
1919					1919				
Mar. 3	19,674	4,593	15,422	4,352	Mar. 21	13,749	6,124	13,919	3,515
" 4	18,031	4,905	17,151	4,678	" 22	10,801	3,147	15,138	3,487
" 5	16,188	5,103	11,879	4,649	" 23	11,992	4,253	17,549	3,260
" 6	13,721	4,536	12,786	3,572	" 24	13,580	3,062	17,436	3,175
Total.....	67,614	19,137	57,238	17,251	50,122	16,586	64,042	13,437
Average.....	16,903	4,784	14,309	4,313	12,530	4,146	16,010	3,359
Mar. 7	15,082	4,196	17,436	0	Mar. 25	13,636	3,742	20,355	3,600
" 8	14,260	4,990	15,196	6,861	" 26	11,850	3,544	18,257	3,969
" 9	14,571	4,593	17,123	3,062	" 27	11,312	4,026	15,649	3,856
" 10	14,006	6,832	16,642	3,317	" 28	12,219	3,544	18,285	1,673
Total.....	57,919	20,611	66,397	13,240	49,017	14,856	72,546	13,098
Average.....	14,480	5,153	16,599	3,310	12,254	3,714	18,136	3,274

TABLE VIII.
Composition of Moist Feces.

Period.	No. 51.				No. 63.			
	Water.	Nitro- gen.	Cal- cium.	Phos- phorus.	Water.	Nitro- gen.	Cal- cium.	Phos- phorus.
<i>1919</i>	<i>per cent</i>	<i>per cent</i>	<i>per cent</i>	<i>per cent</i>	<i>per cent</i>	<i>per cent</i>	<i>per cent</i>	<i>per cent</i>
Mar. 3-6.....	85.86	0.2950	0.2037	0.1178	85.45	0.3212	0.2200	0.1820
“ 7-10.....	85.09	0.3095	0.2438	0.1390	86.63	0.2912	0.1925	0.1560
	No. 66.				No. 63.			
Mar. 21-24.....	83.84	0.3441	0.2393	0.1881	86.19	0.2921	0.2017	0.1004
“ 25-28.....	82.66	0.3608	0.3043	0.2436	85.91	0.2839	0.1984	0.1017

TABLE IX.
Composition of Urine.

Period.	No. 51.				No. 63.			
	Specific gravity.	Nitro- gen.	Cal- cium.	Phos- phorus.	Specific gravity.	Nitro- gen.	Cal- cium.	Phos- phorus.
<i>1919</i>		<i>per cent</i>	<i>per cent</i>	<i>per cent</i>		<i>per cent</i>	<i>per cent</i>	<i>per cent</i>
Mar. 3-6.....	1.037	1.0824	0.0183	0.0019	1.038	1.0832	0.0007	0.0208
“ 7-10.....	1.035	0.9928	0.0183	0.0016	1.038	1.3196	0.0009	0.0263
	No. 66.				No. 63.			
Mar. 21-24.....	1.042	1.2311	0.0121	0.0020	1.037	1.0789	0.0016	0.0032
“ 25-28.....	1.045	1.4203	0.0090	0.0021	1.036	0.9352	0.0013	0.0031

TABLE X.

Average Daily Intake, Output, and Balance of Nitrogen, Calcium, and Phosphorus.

Cow No.	Period.	Nitrogen.	Calcium.	Phosphorus.
		Food. Feces. Urine. Balance.	Food. Feces. Urine. Balance.	Food. Feces. Urine. Balance.
	1919	<i>gm.</i>	<i>gm.</i>	<i>gm.</i>
51	Mar. 3-6	117.50	38.81	23.39
		49.87	34.43	19.91
		51.78	0.88	0.09
		+15.85	+3.50	+3.39
51	Mar. 7-10	110.01	37.33	22.27
		44.81	35.30	20.13
		51.16	0.94	0.08
		+14.04	+1.09	+2.06
63	Mar. 3-6	96.66	32.42	30.37
		45.96	31.48	26.04
		46.72	0.03	0.90
		+3.98	+0.91	+3.43
63	Mar. 7-10	97.29	33.63	30.51
		48.34	31.95	25.89
		43.68	0.03	0.87
		+5.27	+1.65	+3.75
66	Mar. 21-24	98.36	35.47	30.99
		43.12	29.99	23.57
		51.04	0.50	0.08
		+4.20	+4.98	+7.34
66	Mar. 25-28	94.61	35.32	30.85
		44.21	37.29	29.85
		52.75	0.33	0.08
		-2.35	-2.30	+0.92
63	Mar. 21-24	99.20	35.27	20.61
		46.77	32.29	16.07
		36.24	0.05	0.11
		+16.19	+2.93	+4.43
63	Mar. 25-28	94.76	34.59	20.49
		51.49	35.98	18.45
		30.62	0.04	0.10
		+12.65	-1.43	+1.94

TABLE XI.
Composition of Blood Samples.

Cow No.	Date.	Total blood P per 100 gm.	Blood corpuscles.	Plasma.			Calcium per 100 gm.
				Phosphorus.			
				Total per 100 gm.	Lipoid* per 100 gm. calculated.	Inorganic per 100 gm.	
	1919	mg.	vol. per cent	mg.	mg.	mg.	
51	Feb. 17	15.7	34.6	9.9	4.9	5.0	Not determined.
	Mar. 3	15.9	34.1	10.1	4.3	5.8	" "
	" 11	15.3	32.5	9.6	4.2	5.4	9.5
63	Feb. 17	18.3	38.9	12.3	5.2	7.1	Not determined.
	Mar. 3	18.2	41.0	11.5	5.3	6.2	" "
	" 11	17.4	40.4	11.9	5.4	6.5	9.7
	" 21	17.2	39.4	9.6	4.4	5.2	9.6
	" 29	17.5	42.6	10.3	5.0	5.3	9.5
66	Mar. 21	18.1	40.4	11.9	6.0	5.9	10.1
	" 29	17.9	45.8	12.1	6.1	6.0	9.7

*Lipoid phosphorus calculated by subtracting inorganic from total (Meigs, E. B., Blatherwick, N. R., and Cary, C. A., *J. Biol. Chem.*, 1919, xxxvii, 10-17).

TABLE XII.
*Calcium and Phosphorus in Urine and Blood Plasma.**

Cow No.	Date.	Plasma.		Urine.			
		Calcium.	Inorganic phosphorus.	Calcium.	Phosphorus.	Daily calcium excretion.	Daily phosphorus excretion.
		<i>per cent</i>	<i>per cent</i>	<i>per cent</i>	<i>per cent</i>	<i>gm.</i>	<i>gm.</i>
51	1919 Feb. 17	Not determined.	0.0050	Not determined.	0.0017	Not determined.	0.0689
	Mar. 3	" "	0.0058	0.0183	0.0019	0.8755	0.0907
	" 11	0.0095	0.0054	0.0183	0.0016	0.9425	0.0818
63	Feb. 17	Not determined.	0.0071	Not determined.	0.0099	Not determined.	0.3817
	Mar. 3	" "	0.0062	0.0007	0.0208	0.0303	0.8979
	" 11	0.0097	0.0065	0.0009	0.0263	0.0293	0.8706
	" 21	0.0096	0.0052	0.0016	0.0032	0.0543	0.1093
	" 29	0.0095	0.0053	0.0013	0.0031	0.0423	0.1006
66	Mar. 21	0.0101	0.0059	0.0121	0.0020	0.5000	0.0827
	" 29	0.0097	0.0060	0.0090	0.0021	0.3340	0.0774

*In this table the concentrations of calcium and phosphorus in the blood plasma are taken as corresponding to the concentrations in the urine of the nearest collection period. For instance, the plasma obtained Mar. 3 is taken as corresponding to the urine collected in the period Mar. 3-6; the plasma obtained Mar. 11, to the urine collected Mar. 7-10; and so on. On Feb. 17, 18 hour samples of urine were specially collected to compare with the blood samples obtained on that date.

FAT-SOLUBLE VITAMINE.*

II. THE FAT-SOLUBLE VITAMINE CONTENT OF ROOTS, TOGETHER WITH SOME OBSERVATIONS ON THEIR WATER-SOLUBLE VITAMINE CONTENT.

BY H. STEENBOCK AND E. G. GROSS.

WITH THE COOPERATION OF M. T. SELL.

*(From the Laboratory of Agricultural Chemistry, University of Wisconsin,
Madison.)*

PLATE 1.

(Received for publication, October 24, 1919.)

In the evolution of the modern conception of the dietary needs of the body there has come an appreciation of the significance of small amounts of those indispensable nutritive factors known as vitamins; but unfortunately with this appreciation there has been aroused much apprehension in the minds of many in regard to the wisdom of omitting certain foods from the human diet for fear of unknowingly reducing the vitamin content of the diet to dangerous limits. While it is not intended to depreciate the value of discretion in the selection of the ingredients of the diet for reasons other than satisfying the requirements of palatability, good proteins, and mineral elements, it is deemed rather unfortunate that conclusions should have been hastily drawn and promiscuously applied after only a limited survey of the dietary properties of our naturally occurring foods had been made, and especially when such were made with animals about which we have no information as to their requirements when compared with those of man. Taking into consideration the apparent limitations imposed on methods of experimental inquiry now in use, what seems most desirable above all else—after the development of sufficient theory to serve as a suitable working basis—is the accumulation of sufficient data which may give an insight into the specific comparative nutritive properties of dif-

* Published with the permission of the Director of the Wisconsin Agricultural Experiment Station.

ferent foods. Such information seems especially called for by the great interest shown by dietitians in the occurrence and stability of the vitamins.

It is now generally recognized that of the substances which are collectively known as vitamins there are three distinct kinds; namely, the water-soluble or antineuritic vitamin, the fat-soluble or antixerophthalmic vitamin, and the antiscorbutic vitamin. In the present series of papers it is planned to confine the discussion to the fat-soluble vitamin, but incidentally certain points of interest in connection with the water-soluble vitamin will be mentioned, especially with reference to the determination of the amount present so that it could not possibly be a limiting factor in the performance of the animals on any of the rations which it was desired to test for the relative fat-soluble vitamin content. Various phases of the water-soluble vitamin question will be published in another connection.

The specific growth-promoting property which is now associated with the occurrence of the fat-soluble vitamin was first dissected from different factors, though functioning in a similar capacity, when McCollum and Davis¹ in 1913, in a study of the value of different salt mixtures, observed that in a synthetic ration an ether extract of butter or egg yolk had a stimulating action on growth which was not possessed by other fats such as lard or olive oil. Very shortly thereafter Osborne and Mendel² published experiments, some of them of 180 days duration, where it was pointed out that their milk rations had special dietary properties not found in their milk-free rations and that this characteristic seemed to be true of rations carrying an equivalent amount of butter as well. Later³ they demonstrated in very conclusive experiments, more so than any published up to that time, that this property resided in the butter fat. Furthermore, they substantiated McCollum and Davis' observation that egg yolk fat was efficient in this respect and added that "some other oils" were no more efficient than lard. In 1914 Osborne and Mendel⁴ reported

¹ McCollum, E. V., and Davis, M., *J. Biol. Chem.*, 1913, xv, 167.

² Osborne, T. B., and Mendel, L. B., *J. Biol. Chem.*, 1913, xv, 311.

³ Osborne, T. B., and Mendel, L. B., *J. Biol. Chem.*, 1913-14, xvi, 423.

⁴ Osborne, T. B., and Mendel, L. B., *J. Biol. Chem.*, 1914, xvii, 402.

"We have likewise obtained uniform success by substituting cod liver oil for a portion of the lard in our standard diets. . . . In contrast with this are the uniformly observed failures of almond oil to restore growth when it had ceased on the usual lard food mixtures."

It is not intended to give here a résumé of the findings of others with respect to the occurrence of the fat-soluble vitamine in fats, grains, leaves, and other food materials, as that has already been done in a most excellent manner by Osborne and Mendel⁵ and by Emmett and Luros,⁶ nor do we intend to comment extensively as to the merits of the recorded observations. It is, however, safe to venture that the time is not yet ripe to warrant general classification of foods into groups rich, poor, and free from fat-soluble vitamine as general methods of experimentation, especially in reference to vitamine content of the basal food ingredients, period of observation, and control of experimental animals, differ so greatly in different laboratories that the conclusions of the different observers are hardly comparable. Furthermore, there is much reason to believe, as will be brought out in later papers, that the variation in the fat-soluble vitamine content of naturally occurring food materials, even when harvested at the same stage of development, is tremendous. No doubt there lies here the foundation for many interesting correlations in the functional rôle of specific substances in both plant and animal kingdoms, the significance of which can scarcely be predicted.

One correlation that has been advanced is an apparent attempt to associate a richness in vitamine content with the occurrence of a preponderance of actively functioning cells.⁷ This deduction would seem to be based on a recognition of the great indispensibility of the vitamines for growth and an assumption that the vitamines are equally indispensable in individual physiological processes, none the less active, but of a highly specialized character. Suffice it to say that as nothing of the specific internal rôle of vitamines is known outside of the pharmacological findings of Uhlmann,⁸ who, however, worked with extracts

⁵ Osborne, T. B., and Mendel, L. B., *J. Biol. Chem.*, 1917, xxxii, 309.

⁶ Emmet, A. D., and Luros, G. O., *J. Biol. Chem.*, 1919, xxxviii, 441.

⁷ McCollum, E. V., *J. Home Econ.*, 1918, x, 195.

⁸ Uhlmann, F., *Z. Biol.*, 1917-18, lxviii, 419, 457.

of very complex character, such generalizations appear gratuitous. In this connection a high vitamine content of liver tissue, instead of being due to or associated with its activity as a glandular organ, might with equal propriety be assumed on the basis of its well known functions as a storage organ, or might possibly be attributed to the absorption of substances not indispensable to the organ but absorbed due to an inefficiency of the mechanism which excludes the entrance of substances in amounts greater than the needs as these substances are brought to it in the portal circulation. Similarly, the high vitamine content of the kidney may be said to be due to the temporary retention of the vitamins as unutilizable amounts of them found in the ration are eliminated.

One thing appears reasonably certain: In the plant kingdom the occurrence of the vitamine cannot always be associated with a preponderance of actively functioning cells as distinguished from those that serve primarily as storage organs. This is brought out in an analysis of our data on the occurrence of the fat-soluble vitamine in tubers and roots even though all must be considered storage organs for those constituents that are needed by the growing plant in the following season.⁹ The sweet potato, as an example of the tuber, is rich in this vitamine, while the rutabaga and the potato contain relatively little of this constituent. Similarly, among the roots carrots contain much of it as has been suggested by the work of Denton and Kohman,¹⁰ while mangels and sugar beets are poor in it. Results will be discussed in further detail under the various following experimental headings.

EXPERIMENTAL.

The relative amounts of vitamine present in the tubers and roots were determined by incorporating various percentages of them in a basal rat ration which already satisfied all other nutritive requirements, and which was as free from the vitamins as ordinary methods of laboratory manipulation could produce them. We have repeatedly demonstrated that the basal constituents of our rations were too poor in vitamins to influence in any way

⁹ Steenbock, H., *Science*, 1918, xlvii, 119.

¹⁰ Denton, M. C., and Kohman, E., *J. Biol. Chem.*, 1918, xxxvi, 249.

the conclusions at which we have arrived, but on the other hand we make no claim that very small amounts of some vitamins may still not have been present and thus may have influenced in degree—though not in character—failure in maintenance, growth, reproduction, and rearing of the young as indicated by the experimental rats. This will readily be appreciated on inspection of the charts in the various groups. When failure in growth or maintenance resulted and this was suspected as being due to a vitamin deficiency this was often incontrovertibly established by adding additional water or fat-soluble vitamin and noting the result. The water-soluble vitamin was added in the form of an alcoholic extract of ether-extracted wheat embryo evaporated on dextrin, while the fat-soluble vitamin was added as found in butter fat obtained by melting and filtering butter fat at a low temperature. The dextrin used was partially dextrinized corn-starch prepared by heating the starch with 0.1 per cent citric acid solution in an autoclave for a number of hours and then drying and grinding it. The casein was prepared from commercial casein by washing it repeatedly with distilled water acidified with acetic acid for an entire week and then drying and pulverizing it. Salts were incorporated in the rations in the form of artificial salt mixtures prepared from purified reagents.¹¹

¹¹ The salt mixtures used had the following composition,—

Salt 35:

NaCl.....	1.0
CaCO ₃	1.5

Salt 1:

NaCl.....	0.173
MgSO ₄ (anhydrous).....	0.266
NaH ₂ PO ₄ H ₂ O.....	0.347
K ₂ HPO ₄	0.954
CaH ₄ (PO ₄) ₂ H ₂ O.....	0.540
Fe citrate.....	0.118
Ca lactate.....	1.300

Salt 32:

NaCl.....	0.202
MgSO ₄ (anhydrous).....	0.311
Na ₂ HPO ₄ 12H ₂ O.....	0.526
K ₂ HPO ₄	1.115
Ca ₂ H ₂ (PO ₄) ₂ H ₂ O.....	1.116
Ca lactate.....	0.289
Fe citrate.....	0.138

When these experiments were initiated no data on the heat stability of the fat-soluble vitamine as found in plant materials were available. From the work of McCollum and Davis who showed that this vitamine was still contained in the yolk of hard boiled eggs¹² and from the work of Osborne and Mendel¹³ on the stability of the vitamine in butter fat the idea was generally prevalent that this vitamine was thermostable. We¹⁴ did not find this conclusion generally acceptable after we had demonstrated to our satisfaction that though the reaction is one of slow velocity the fat-soluble vitamine in butter fat is destroyed by heat. It might be mentioned that this observation has since been substantiated by Drummond.¹⁵ As in the materials that we used, the vitamines are in contact with many different compounds and as no data on the stability of the vitamine under these conditions were available we were forced to adopt the procedure of carrying out all our drying operations at a low temperature wherever possible as the roots had to be dried for comminution and introduction into the ration. Usually the roots were dried at room temperature in an air current and later over anhydrous calcium chloride. In isolated instances, as later noted, it was necessary to use higher temperatures and in some instances it was even found necessary to cook the roots to make them digestible. Later on as our experiments progressed we found that the fat-soluble vitamine as found in plant materials was very stable to heat¹⁶ so that we were able to allow ourselves more leeway in the variety of treatments to which the materials were subjected. Variations from the regular procedure are noted and discussed under the various experimental groups.

Fat-Soluble Vitamine in Carrots.

The roots were washed free from all extraneous material and then pulped on a power beet rasp. In this condition they dried readily in an air current at room temperature. To secure fine

¹² McCollum, E. V., and Davis, M., *Proc. Soc. Exp. Biol. and Med.*, 1913-14, xi, 101.

¹³ Osborne, T. B., and Mendel, L. B., *J. Biol. Chem.*, 1915, xx, 381.

¹⁴ Steenbock, H., Boutwell, P. W., and Kent, H. E., *J. Biol. Chem.*, 1918, xxxv, 517.

¹⁵ Drummond, J. C., *Biochem. J.*, 1919, xiii, 81.

¹⁶ Unpublished data.

comminution they were often dried over calcium chloride for a few days after which they could readily be ground to an impalpable powder in a ball mill. Usually, however, grinding in an Excelsior mill was sufficient to pulverize the pulp to a degree which prevented any picking out of the ration by the experimental animals. With the high sugar content of carrots good consumption of a high percentage carrot ration was generally secured. They were fed at levels of 5, 10, 15, 25, and 60 per cent with and without water-soluble and fat-soluble vitamine additions.

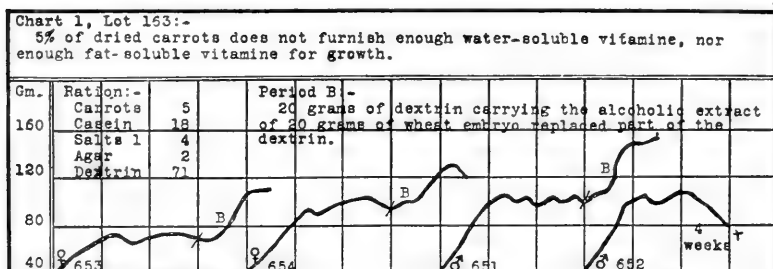

CHART 1. As seen in the chart when a ration satisfactory in all other respects is dependent for its vitamine content on 5 per cent of dried carrots there results partial failure in the growth performance which is not entirely corrected by an addition of water-soluble vitamine in the form of an alcoholic extract of ether-extracted wheat embryo. This indicates that this amount of dried carrots does not furnish a sufficiency of either the water or the fat-soluble vitamine. Rat 652 had an attack of xerophthalmia after having been on the ration 6 weeks. It was, however, but a mild attack as later during its 12th week its eyes were in good condition. At this time and for 3 weeks previously it was losing weight rapidly which appeared to be caused by the insufficiency of water-soluble vitamine as it succumbed to an acute attack of polyneuritis. Rat 653 was blinded by xerophthalmia at the end of the 10th week, but no irreparable damage was done by the acute inflammation and 2 weeks later its eyes were entirely normal. We have in this lot an instance where presence of a subnormal amount of one vitamine was apparently brought to light by a similar situation with respect to another vitamine. When the deficiency of the water-soluble vitamine was corrected the amount of fat-soluble vitamine originally present was able to allow some further growth to result. This statement can be made on the basis of results brought out later (Charts 8 to 34) which indicate that the amount of fat-soluble vitamine introduced with the water-soluble vitamine could not have been responsible for the temporary response when this was added. It brings out one of the innumerable instances where a tendency to one nutritive deficiency heightens the susceptibility and results in the onset of symptoms resulting from similar or other unfavorable environmental conditions.

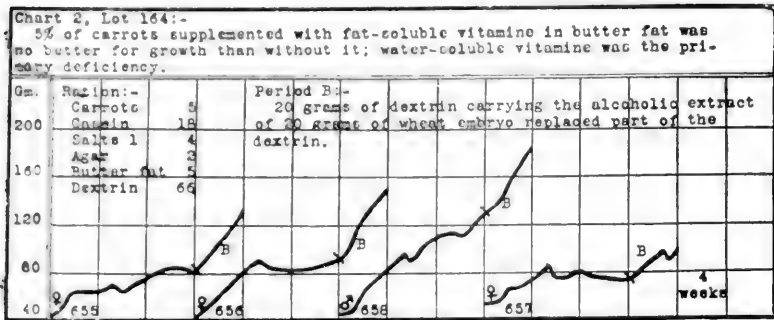

CHART 2. In this lot when the ration was already fortified with additional fat-soluble vitamine in the form of butter fat, while the growth performance was not any better than without this addition, the augmented rapidity of growth was remarkable when additional water-soluble vitamine was added as indicated in Chart 1. This shows—what had been surmised—that the primary vitamine deficiency in a ration carrying only 5 per cent of dried carrots is due to an insufficiency of the water-soluble vitamine.

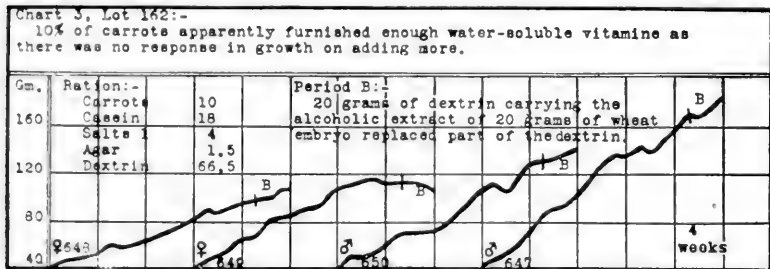

CHART 3. It appears that a ration carrying 10 per cent of dried carrots contains enough water-soluble vitamine to allow considerable growth. This is inferred from the fact that in this lot no response in augmented rapidity of growth resulted when more water-soluble vitamine was added when it was established that even in a ration carrying 5 per cent of carrots the primary deficiency was one of this vitamine. Growth here too was far from normal, but as the animals remained in fine condition during the 20 weeks of experimentation it may be taken as another instance where a ration may not be glaringly deficient in any one dietary factor, but still a suboptimal content of a number of dietetically indispensable constituents may still prevent growth from proceeding at the normal rate.

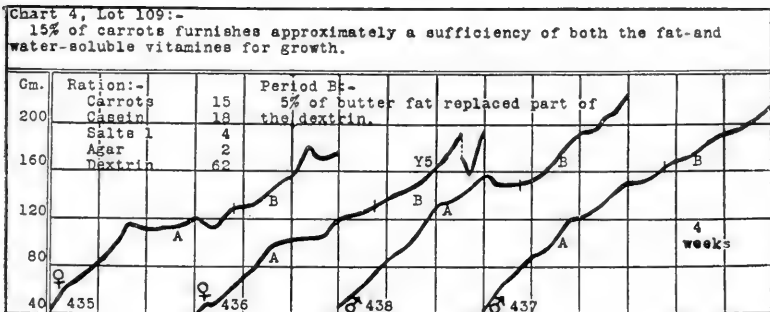

CHART 4. On a ration containing 15 per cent of carrots as the sole source of vitamins, rats are able to continue their growth to maturity at a rate slightly below that possible on our basal ration when suitably supplemented. Rat 436, after the ration had been supplemented with an additional amount of the fat-soluble vitamin, which had no apparent effect on growth, produced a litter of five young. While normal in weight—they weighed 25 gm.—they failed to be nourished by the mother rat and soon succumbed. An individual failure of this kind has, however, no special significance as regards reproduction.

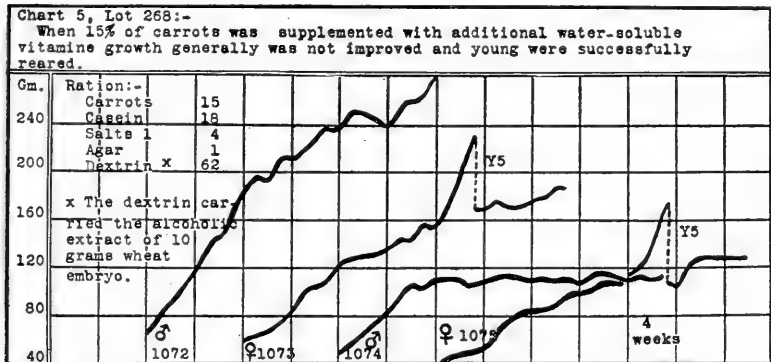

CHART 5. 15 per cent of carrots when supplemented with an additional amount of the water-soluble vitamin did not, with one exception, induce any better growth than when not so supplemented (Chart 3). Rats 1074 and 1075 were decidedly stunted. They gave the impression of being shorter in body length than their weight would normally call for. We have never seen this effect occur in rats where normal growth was disturbed by a lack of vitamins in the diet, but it is a common occurrence where stunting has resulted from digestive disturbances. That the poor growth performance of these animals was not due to a vitamin deficiency is distinctly indicated by the fact that Rats 1073 and 1075 reared five out

of the ten young that they produced. In our experience, the quantity of vitamins required by the rat for normal milk production is considerably greater than that necessary for normal growth. The young reared were, however, far from being normal as they did not attain an average weight of 45 gm. until they were 55 days old; normally in our stock this weight is attained in less than half that time. When weaned, some of the young were very much bloated which gave us our first evidence that the analysis, attributing the cause of the small size of Rats 1074 and 1075 to digestive disturbances rather than to a vitamin deficiency, was probably correct.

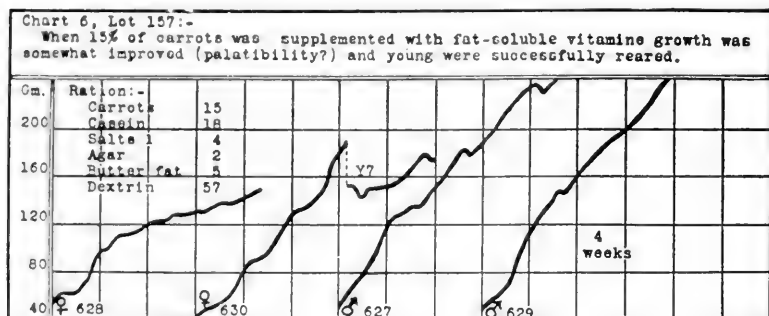

CHART 6. Lot 157 offers additional evidence to that already brought out in Lot 268, Chart 5, that 15 per cent of carrots introduces enough water-soluble vitamins into the diet for normal growth requirements and even for the rearing of some young. In fact there must have been a considerable excess for growth otherwise young could not have been reared as conditions in the tract could not be considered normal. To a certain extent, growth in this lot is better than in Lot 268 where butter fat was not added and water-soluble vitamins was added instead, but it is not pronounced enough to be given special significance.

As in Lot 268 young were reared although only two out of the seven and that at approximately the same subnormal rate, the two together weighing only 111 gm. when 56 days old. In the light of this it is certain that the retarded development of the young was not caused by an insufficiency of the fat-soluble vitamins. Furthermore, in none of the animals was there ever any indication of xerophthalmia.

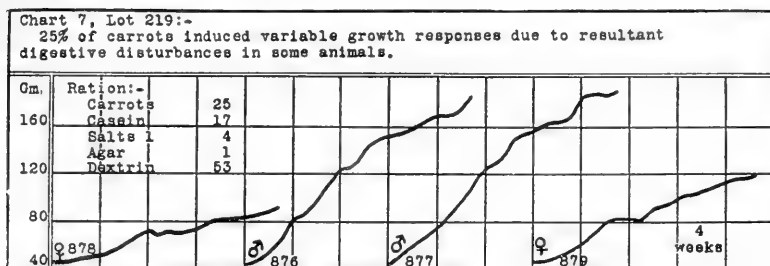

CHART 7. As already indicated by the results pictured in Charts 5 and 6 a high content of carrots in the ration is liable to cause digestive disturbances and as a result of difference in the power of resistance to these disturbances there is considerable variation in the growth performance of different animals. When the amount of carrots is increased to 25 per cent these differences become still more marked as the disturbances are aggravated so that tympanites was regularly observed.

It is to be noted that the results obtained on these carrot rations even when carrying but a low percentage of carrots were never entirely satisfactory from the standpoint of normal nutrition. When the carrot content was too low, the vitamine deficiency would become evident, and if too high or even just high enough for the proper vitamine relations, the large amount of fermentable but indigestible carbohydrate introduced into the ration would cause digestive disturbances and the resultant marked interference with normal growth. For this reason it was not considered advisable to introduce more than 25 per cent of carrots into the ration. In one case where as much as 60 per cent of carrots was fed diarrhea and tympanites always resulted and rendered the results difficult of interpretation.

By adopting such a low level of carrots in the diet that the disturbing effects were minimized, we were able to demonstrate that carrots are remarkably rich in the fat-soluble vitamine. In spite of growth not being entirely satisfactory, this is the only conclusion that can be arrived at in view of our findings that on as low a level as 15 per cent of carrots as the sole source of the fat-soluble vitamine female rats are able to raise their young without any indications of a deficiency.

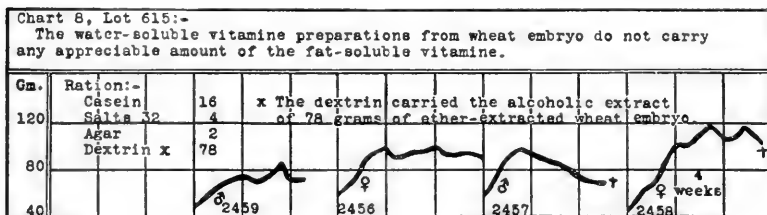

CHART 8. In experiments where additional water-soluble vitamine was added the amount of fat-soluble vitamine added with it was extremely

small as brought out by the growth performance of Rats 2456 and 2459 where they received almost three times as much of the preparation as any of the other experimental groups. In this group Rat 2458 died from xerophthalmia and Rats 2456 and 2459 both had inflamed eyes at the time of their death. It is not necessary therefore to make any reservations in the conclusions so far drawn with respect to the amounts of fat-soluble vitamine present in those rations where water-soluble vitamine had also been added.

From our data and from what is known of their antiscorbutic properties it appears that the practice of feeding carrots in lieu of green materials in vogue by many small animal breeders is dietetically justified from the vitamine standpoint alone. It is also possible that herein lies experimental justification for the use of carrot juice as an adjuvant to the boiled milk diet of children.

Fat-Soluble Vitamine in Swedes or Rutabagas.

The roots used in these experiments were of a pale yellow color and of excellent quality. They were washed, pulped, and then dried in an air current at room temperature and subsequently over calcium chloride to facilitate their comminution in our milling apparatus. When fed, exposure to the air and light had bleached them until they were almost void of all yellow color.

Chart 9, Lot 181:-
15% of rutabagas carries plenty of the water-soluble vitamine not only for growth but even for the rearing of young.

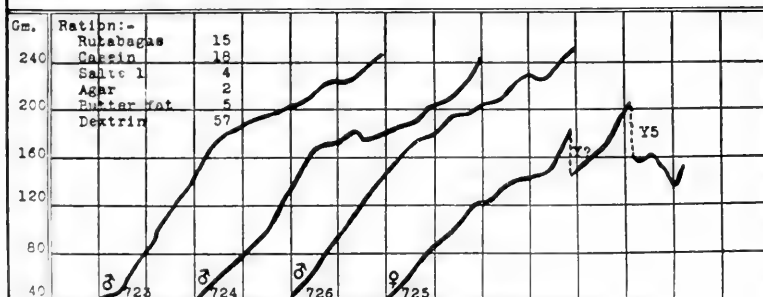

CHART 9. As it is always necessary to insure a sufficiency of all the dietary requirements outside of the unknown which it is desired to determine, a diet containing 15 per cent of rutabagas suitably supplemented with casain and salts was also supplemented with a sufficiency of the fat-soluble vitamine as found in butter fat to allow determination of the

amount of water-soluble vitamine present. As is seen in the chart, growth was practically normal, furthermore Rat 725 reared her second litter of young to weaning. Their growth was not entirely normal, yet they averaged 42 gm. in weight when 33 days old which speaks well for the nutritive sufficiency of the ration. All the rats were in good condition at the time of termination of the experiment, 24 weeks after its inauguration.

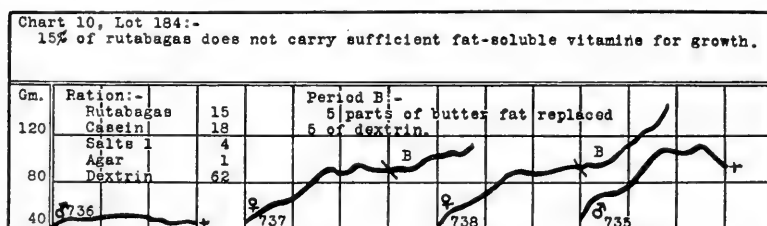

CHART 10. With a sufficiency of the water-soluble vitamine in 15 per cent of rutabagas established (Chart 9), it was comparatively an easy matter to determine its relative fat-soluble vitamine content. Unlike carrots (Chart 4) 15 per cent of rutabagas as the sole source of the fat-soluble vitamine leads to early indications of its deficiency. Rat 735 became afflicted with xerophthalmia which ultimately, after 12 weeks, was the immediate cause of its death. Rat 737 likewise contracted xerophthalmia, but on the addition of fat-soluble vitamine in the form of butter fat, the inflammation disappeared rapidly so that no further signs of it were noted during the last 6 weeks of the experiment; simultaneously it more than maintained its weight and appeared to be in fair nutritive condition. Rat 738, while it had not contracted xerophthalmia, improved remarkably in appearance after the addition of butter fat to its ration. It was short, however, and gave the impression of having been stunted not by a nutritive deficiency, but by digestive disturbances.

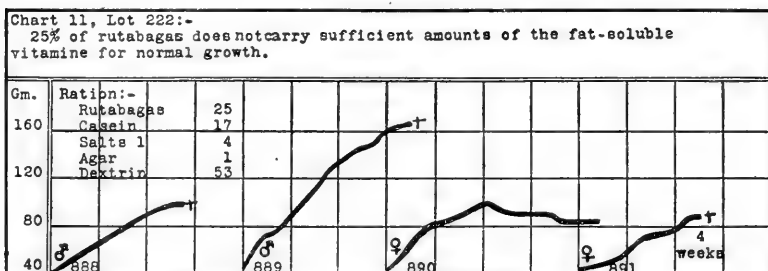

CHART 11. When the amount of rutabagas was increased to 25 per cent of the ration the demands for fat-soluble vitamine still remained unsatisfied. This cannot be inferred from the observed failure of normal

growth to result because digestive disturbances attributed to the hemi-cellulose variety of carbohydrates complicated the situation just as in the case of the carrots. Rat 890 was the only rat that contracted xerophthalmia. Rat 889 was bloated almost continually and ultimately died from this condition. We are inclined to believe that the more pronounced tympanites was due to the greater amount of food consumed by this animal. If it consumed more food, this would easily explain its more pronounced growth as thereby its vitamine intake was satisfied. In such instances as this individual records of food consumption would facilitate the interpretation of data. In most instances, however, accurate conclusions can be arrived at by the law of averages. In the case of Rats 888 and 891 no tympanites was observed and at the time of their death their eyes were perfectly normal.

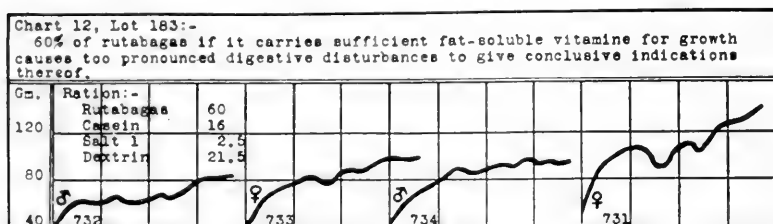

CHART 12. Whether sufficient amounts of fat-soluble vitamine to satisfy the requirements for growth in the rat can be introduced into the ration with dried rutabagas is difficult of determination. Whenever large amounts of the root are incorporated in the diet digestive disturbance which appeared even when only 25 per cent of the root was fed became so aggravated that normal growth was impossible. At a level of 60 per cent it is noteworthy that while the diet was rendered distinctly unfavorable for growth on account of the persistent tympanites and occasional diarrhea no xerophthalmia was observed in any of the animals during the 15 weeks of the experimental period. If the rutabagas contained none of the fat-soluble vitamine it was to be expected that xerophthalmia would have resulted in the presence of these digestive disturbances and over such a protracted period. But final conclusions cannot be arrived at with these limited data. There is no question, however, that if rutabagas contain any demonstrable amounts of the fat-soluble vitamine they are not to be considered comparable to those found in carrots.

Fat-Soluble Vitamine In Dasheens.¹⁷

The dasheens, both corms and roots of medium size and free from foreign material, were sliced without peeling and then dried

¹⁷ The common name of dasheen is taro, and the scientific name *Caladium colucasia*.

at room temperature in an air current. In this condition they could be readily ground to a fine powder and incorporated in the ration. No difficulty in securing consumption was observed.

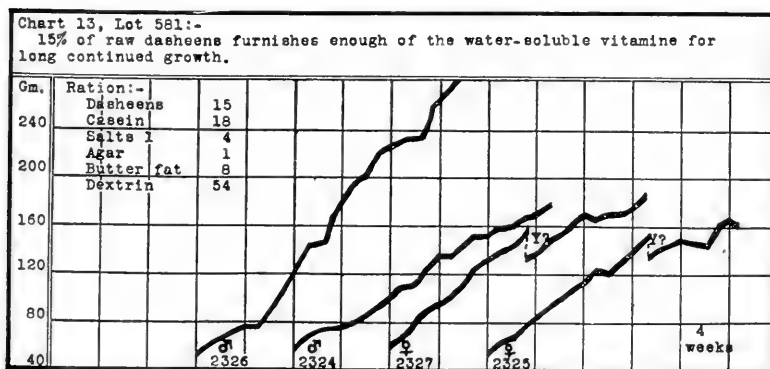

CHART 13. From the performance of the animals in this lot there remains no question but what dasheens are abundantly supplied with the water-soluble vitamine to support long continued growth of the rat. It is true that the observed growth was not what could be considered normal, but nevertheless for our purposes of comparison the results must be considered very satisfactory especially in view of the fact that no rations which can be considered synthetic in any sense of the word are entirely satisfactory even for growth and certainly not for reproduction and rearing of the young.

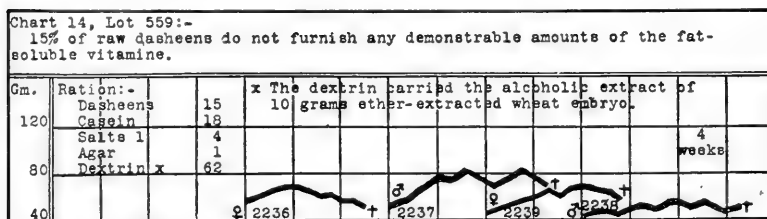

CHART 14. In a ration provided with a liberal excess of the water-soluble vitamine and all other nutritive factors, outside of the fat-soluble vitamine necessary for growth, provided for, 15 per cent of dasheens does not take care of this deficiency to allow even the minimum amount of growth. Rat 2339 became blinded by the resultant xerophthalmia but the other rats in their miserable condition became infested with lice, making it difficult to ascertain definitely before their death—which followed shortly—whether or not the inflamed condition of the eyes was due to the fat-soluble vitamine deficiency or to the irritation. Under the conditions,

the consistent failure of growth together with the occurrence of one clean-cut case of xerophthalmia speaks decisively for a fat-soluble vitamine deficiency in this ration.

In several instances attempts were made to feed a higher percentage of dasheens. This resulted in complete failure, but for reasons which had hitherto not been appreciated. When raw dasheens are fed in liberal amounts it becomes evident that they are very difficultly digestible which fact became especially evident when the amount was increased to as high a content as 80 per cent of the rations. Even though the rations were complete in every way the indigestibility of raw dasheen starch prevented the rats from even maintaining themselves. Large quantities of the feed were devoured at times and bulky fecal residues were eliminated due to the excretion of undigested starch as indicated by the iodine potassium iodide reaction. Autopsy of a number of animals indicated that the abdominal distention which had at first been taken as due to gaseous fermentation was in reality due to an abnormal enlargement of the cecum and large intestine in accommodation to the accumulation of the undigested food.

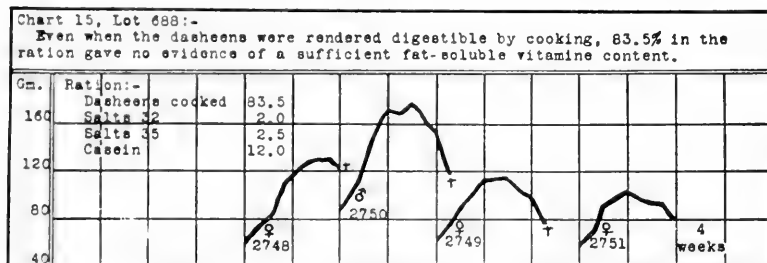

CHART 15. As the indigestibility of the starch precluded the possibility of demonstrating the low fat-soluble vitamine content of dasheens it became necessary to cook them. When cooked, difficulty in the digestibility of the starch was no longer observed, but neither was there made evident the presence of a fat-soluble vitamine content. Viewed in the light of results obtained later we are thoroughly convinced that the data are representative of what would have been obtained on the raw dasheens if results had not been obscured by their indigestibility. It is probable that in spite of their indigestibility when 15 per cent of the raw dasheens was fed if they had contained any demonstrable amount of the vitamine it would still have been shown by the growth responses as the demonstration of the presence of the water-soluble vitamine was not

interfered with by this condition (Chart 13). Furthermore the dasheens fed were cooked at a low temperature (5 pounds steam pressure for 20 minutes) and were then dried at room temperature in an air current. From what we now know of the stability of the fat-soluble vitamine in plant materials the amount destroyed must have been very small if at all demonstrable by feeding experiments. If the fat-soluble vitamine occurs at all in the dasheens it should here have become evident.

Fat-Soluble Vitamine in Red Beets.

The red beets of medium size were scrubbed thoroughly, then sliced, and dried in an air current at room temperature. Under these conditions and even when kept over anhydrous calcium chloride for some weeks they did not dry enough to make it possible to grind them. Only by drying them in a thin layer for 20 minutes at 90° did they become brittle enough to grind and later pulverize to an impalpable powder in a ball mill.

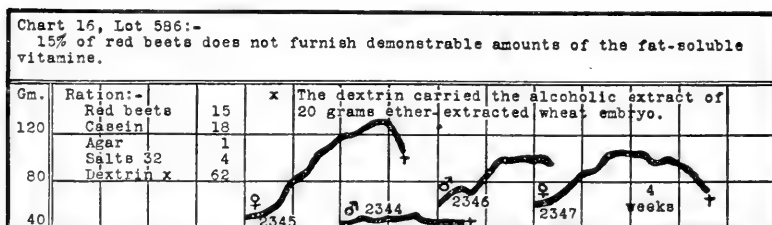

CHART 16. In a ration complete in its content of the dietary essentials requisite for fairly good growth with the exception of the fat-soluble vitamine 15 per cent of red beets does not furnish enough of this vitamine. None of the rats grew at the normal rate for even a limited time and one, Rat 2344, remained absolutely stationary in body weight. Rats 2345 and 2347 developed bad cases of xerophthalmia which persisted to the time of their death. Rat 2344 died without any specific symptoms of vitamine deficiency.

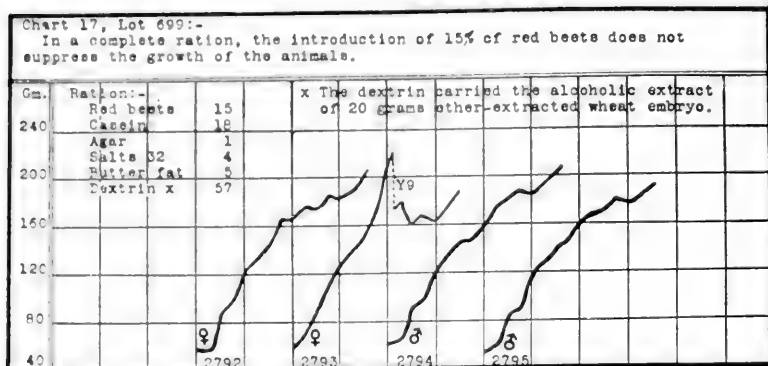

CHART 17. Proof that the failure of growth in Lot 586, Chart 16, was not due to any unfavorable factors in the diet introduced with the 15 per cent of red beets is brought out by this lot of animals. When added to a complete diet no prejudicial effects were observed. It must be remembered, however, that this evidence is not absolute as in a satisfactory ration factors slightly detrimental in action would be obscured by the greater powers of resistance of the animal under these conditions. It can be safely concluded that red beets are very low in or practically free from the fat-soluble vitamine.

Fat-Soluble Vitamine in Parsnips.

The roots were sliced and then dried at room temperature in an air current. While fairly dry, they were sufficiently hygroscopic to remain tough until dried over calcium chloride; after that, they could be readily pulverized. The comminuted preparation was of a faint but clear yellow color which appeared to have greater permanency than the yellow of the rutabagas which as already noted bleached out rapidly.

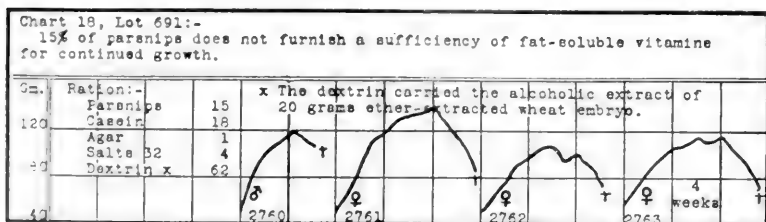

CHART 18. In two experimental lots of which the record of only one, viz. 691, which showed the most growth is here reproduced no evi-

dence of a sufficiency of the fat-soluble vitamine for growth was obtained. Rat 2760 had a severe attack of indigestion resulting in diarrhea which probably was indicative of an unfavorable character of the carbohydrate in the root as demonstrated in the case of the carrot and rutabaga. Rats 2761, 2762, and 2763 all had inflamed eyes at the time of their death, but as the eyes did not become purulent before death we are not positive whether we were dealing with xerophthalmia due to fat-soluble vitamine deficiency or not. In view of the ultimate failure in the growth performance of the rats in two lots, though the ration was initially apparently relished by the animals, together with the incipient eye inflammations we believe we are justified in concluding that parsnips are poor in their fat-soluble vitamine content. We did not determine whether larger amounts might not have been satisfying in furnishing this vitamine.

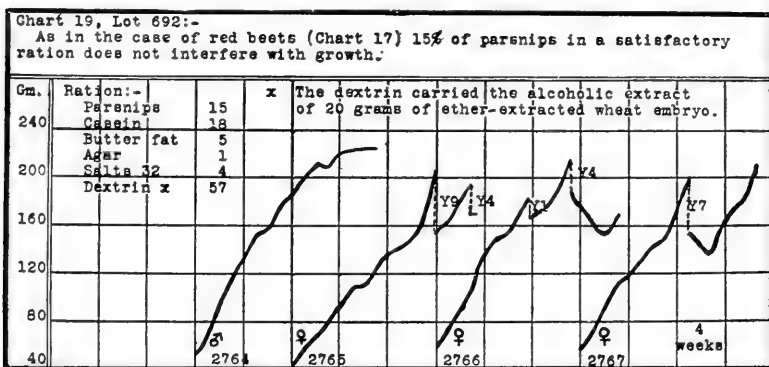

CHART 19. This record makes it positive that failure in Lot 691, Chart 18, was not due to harmful constituents or unpalatable constituents in the parsnips as growth was uniformly satisfactory when the ration was complete. In the 1st week the average consumption was 39 gm. per rat as compared with 40 gm. in Lot 691, in the 2nd week 53 gm. as compared with 57, and in the 3rd week 64 as compared with 64. These records were obtained by means of a special feeding device which it is believed gives as satisfactory data of food consumption as it is possible to secure with rations of the physical characteristics here employed.

Fat-Soluble Vitamine in Potatoes.

The data on the vitamine content of potatoes here reproduced were obtained at various intervals over a considerable period of time and of all the records accumulated, only a few have been presented to indicate the nature of the problem and to present the general trend of the results obtained.

The tubers were bought on the open market and were of medium size. They were washed free from dirt and then sliced without paring. Those fed raw were dried at room temperature while those fed cooked were autoclaved at 15 pounds pressure from 60 to 75 minutes. Generally after cooking they were dried in an oven at 90°C. An exception to this procedure is to be noted, Chart 24, Lot 719, where they were dried in an air current at about 30°C.

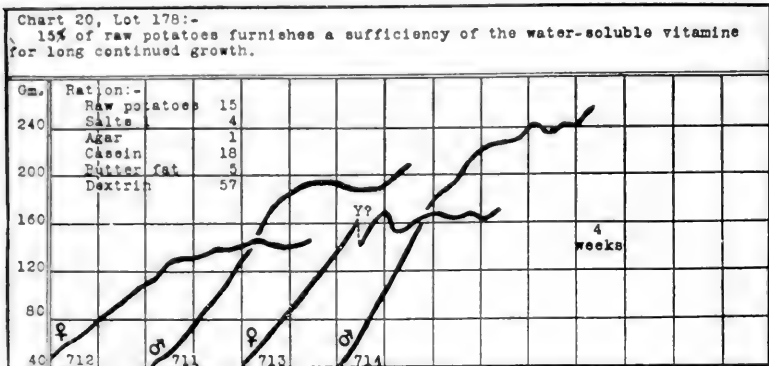

CHART 20. Potatoes furnish us with another instance of the relatively large amounts of water-soluble vitamine present in proportion to the animal's requirements for growth. This does not necessarily mean that the amount present in their diet is generally much larger than the animal requires for its physiological well being—though evidence points in this direction—but it does mean that on a diet of roots the animal is certain to feel the need of other constituents before that of the water-soluble vitamine.

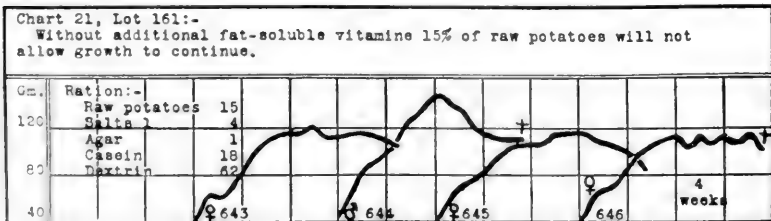

CHART 21. When the ration fed to Lot 178, Chart 20, was not provided with fat-soluble vitamine in addition to that furnished by the 15 per cent of raw potatoes, failure in nutrition results. Here again, then, we have an instance where, relative to the needs of the animal for growth, a

deficiency in the fat-soluble vitamine becomes especially evident. After failure to grow had been decisively indicated the ration was changed to the extent that five parts of dextrin were replaced by five of butter fat. Before the effect of this vitamine addition had become evident the animals died, death being directly due to their poor nutritive condition.

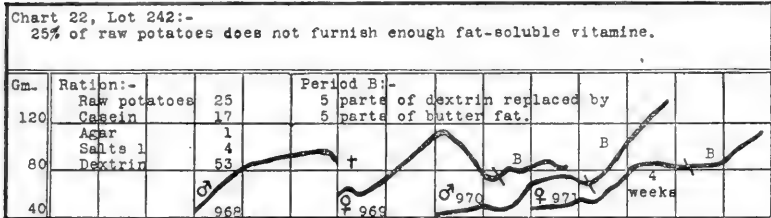

CHART 22. With such amounts of fat-soluble vitamine as are present when 25 per cent of the ration is supplied as raw potatoes, the observed growth performance was less than on 15 per cent (Chart 21, Lot 161). This is due to the fact, as was discovered later when large amounts of raw potatoes were fed, that raw potato starch is digested with great difficulty by the rat. Therefore, as the amount of potato in the ration was increased, such improvement as would result from any additional amount of the fat-soluble vitamine present was masked by the unfavorable effect of the decrease in the amount of available energy. There remains, however, absolutely no doubt that the failure of continued maintenance on this ration was primarily caused by a lack of the fat-soluble vitamine as Rats 968, 969, and 971 all contracted xerophthalmia while on the ration.

In the light of what has been said the improvement in the condition of the rats when butter fat was added as indicated on the chart should not be accepted without reserve as being due to the fat-soluble vitamine thereby added. In part the beneficial results are to be attributed also to the increased intake in the required amount of energy of which the animal was otherwise deprived by the indigestibility of the starch.

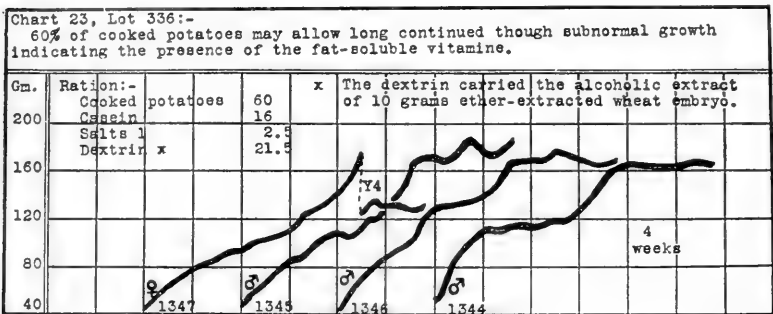

CHART 23. As when even low percentages of raw potatoes were present in the ration there was marked evidence of their indigestibility it

obviously was an impossibility to attempt to demonstrate the presence of the fat-soluble vitamine in such potatoes. Much as we felt disinclined, we were forced to cook them to render them digestible. On potatoes so treated, much to our surprise, the rats continued to grow for a considerable period of time and later maintained themselves for a period of 23 weeks with but 60 per cent of potatoes in the ration as the source of the fat-soluble vitamine. At the end of this time none of the rats gave signs of impending nutritive failure.

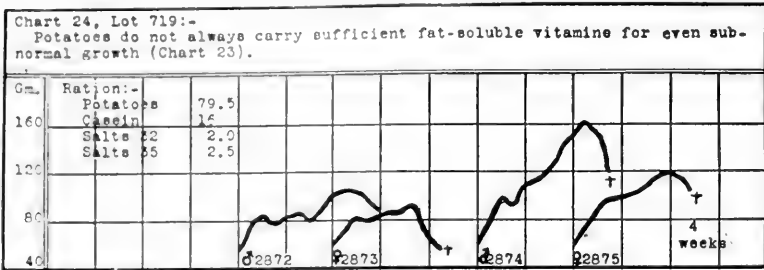

CHART 24. That much reliance is not to be placed on the general occurrence of the fat-soluble vitamine in the potato is brought out in this experiment. The potatoes used were from a different lot, but were prepared for feeding as those used for Lot 330 with the exception that later they were air-dried so that the treatment to which they were subjected was even milder than that used in the other instance and therefore more of the original vitamine content should have been preserved. The general miserable condition of these animals testified to the fact that even with 19 per cent more of potatoes in the ration as compared with Lot 336 there was far less fat-soluble vitamine demonstrable. We are forced to the conclusion that there is considerable variation in the fat-soluble vitamine content of potatoes, a fact the importance of which we did not appreciate until similar observations of variations were obtained with other plant materials. In general it is believed safe to infer that potatoes may contain enough of the fat-soluble vitamine for normal growth, but generally they can be considered poor in their content of this dietary essential.

Fat-Soluble Vitamine in Mangels.

The mangels used in these experiments were a variety known as sugar mangels which are considered of superior value on account of their higher sugar content to the ordinary mangels used as fed by the animal husbandman and so extensively used by the Germans for human food during the time of food scarcity in 1917. They were washed, pulped on a power beet rasp, and then

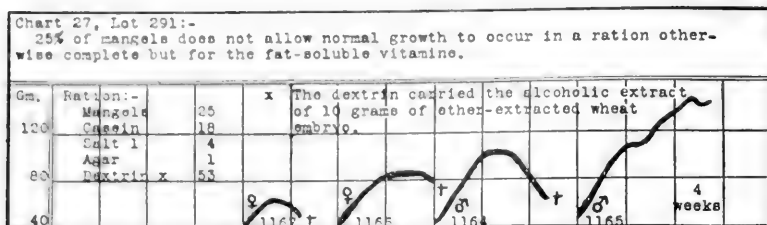

CHART 27. Besides their poverty in the water-soluble vitamine mangels are also deficient in the fat-soluble vitamine as indicated by the results of this experimental group. Rats 1164, 1166, and 1167 died when in a very miserable condition due to a poor nutritive state of the skin. The general condition of Rat 1165 was no better than the others, but it maintained its weight better for the time that the experiment was continued.

Fat-Soluble Vitamine in Sugar Beets.

Sugar beets prepared for feeding by pulping and then drying in an air current at room temperature and finally over calcium chloride indicated the same general vitamine relations as the mangels.

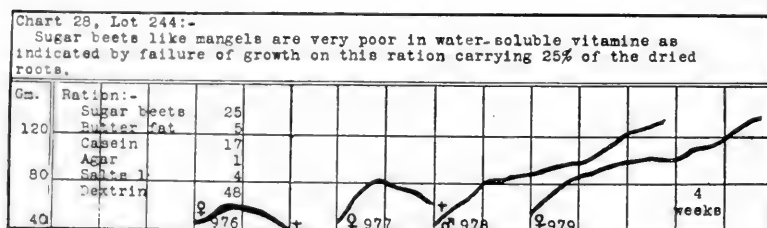

CHART 28. Rats 976 and 977 failed to live longer than 8 weeks on a ration dependent for the water-soluble vitamine on the amount introduced with 25 per cent of sugar beets. Their death was directly due to this deficiency as both died after having shown severe convulsive symptoms common in attacks of polyneuritis. Rats 978 and 979 did not succumb to this deficiency; neither was their growth satisfactory. Such variations are merely instances of certain individuals being better able to withstand an unfavorable environment.

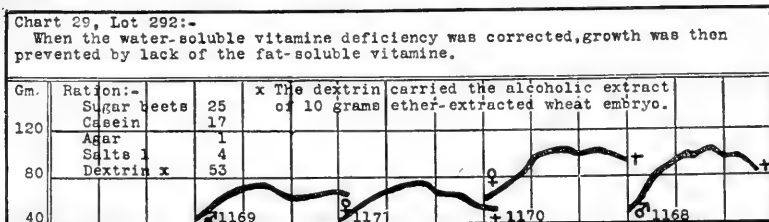

CHART 29. The evidence for a fat-soluble vitamine deficiency in a ration dependent for this dietary essential on 25 per cent of sugar beets was so pronounced that no further experiments to determine this were inaugurated; Rat 1169 was totally blinded by the xerophthalmia, Rat 1170 contracted xerophthalmia in one of its eyes before death, and Rat 1171 in both eyes. It was only in the case of Rat 1168 that no symptoms of vitamine deficiency outside of failure to grow were observed.

Fat-Soluble Vitamine in Yellow Sweet Potatoes.

Next to the Irish potato there is no tuber or root crop which enters into the make-up of the human diet to such a large extent as the yellow sweet potato, especially when it is in season as its poor keeping qualities more than anything else has prevented its continued use. The favor with which it is received in the American home makes a comparison of its dietary properties with the Irish potato important.

The potatoes used for most of the following investigations were peeled potatoes that had been dried at a temperature of 50-60°C. In three instances air-dried potatoes were fed for purposes of comparison.

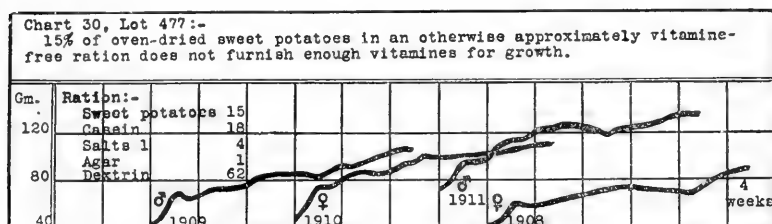

CHART 30. 15 per cent of sweet potatoes as a source of vitamins in the diet of young growing rats led to a very peculiar rate of increase in weight. Growth at a very slow rate was continued for 22 weeks during which there were no signs of polyneuritis or xerophthalmia. The form of the curve, together with the general body condition of the animal—

recorded as good with the exception of Rat 1908 which was designated fair - is most suggestive of a water-soluble vitamine deficiency. Evidently there was just enough vitamine present to maintain the animals. It remained to establish whether or not at this level of sweet potato feeding a deficiency of the fat-soluble vitamine did occur.

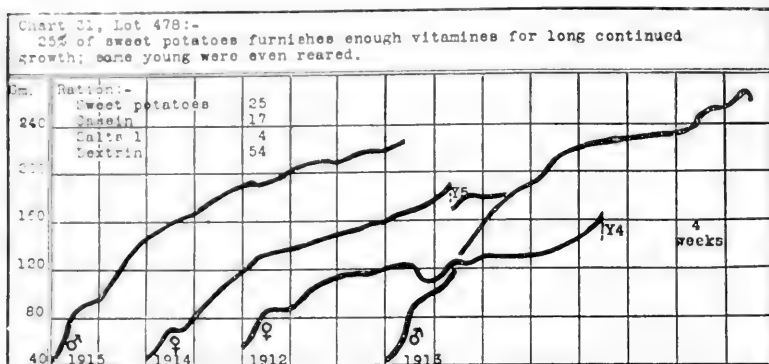

CHART 31. That growth on sweet potato vitamins becomes possible is shown when such an amount of sweet potatoes is introduced into the ration that it makes up 25 per cent of the total. This experimental group indicates that in the previous lot (Lot 477, Chart 30) failure of growth was not primarily due to any unsatisfactory factors introduced into the ration with the potatoes and that therefore it must have been due to a lack of vitamine. The performance of this group of animals is rather remarkable, not only in the growth responses, but also in the fact that one animal, Rat 1914, raised young. She raised three out of a litter of five to an average weight of 37 gm. in 5 weeks. Though undersized they were in good condition.

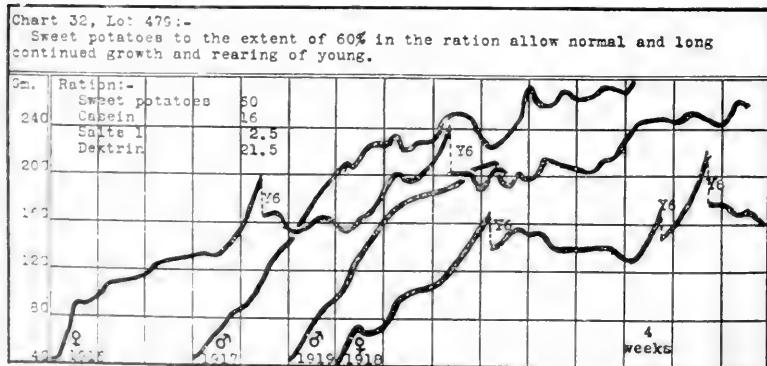

CHART 32. With the per cent of sweet potatoes increased to 60 the growth responses are more nearly what could be considered normal for the

rats of our colony. But as noted on the chart there occurred numerous variations in the weights of the individuals which are indicative of digestive disturbances as often indicated by the bloat observed from time to time. That the vitamine requirement for growth must have been generously satisfied must be inferred from the record of reproduction. Rat 1916 raised five out of a litter of six young to an average weight of 48 gm. in 5 weeks and 4 days, and all of six young from a second litter to an average weight of 42 gm. in 5 weeks (see Plate 1). The other female, Rat 1918, raised two young out of her first litter of six to an average weight of 38 gm. in 7 weeks and all of eight young in her third litter to an average weight of 61 gm. in 7 weeks and 4 days. The second litter was not raised for reasons unknown as they disappeared from the cage a few days after birth, evidently having been consumed by the mother. There certainly is nothing to indicate that the sweet potato cannot be an important source of vitamine in the diet. None of these animals showed any signs of premature senility at 10 months which is further evidence of the satisfactoriness of the diet.

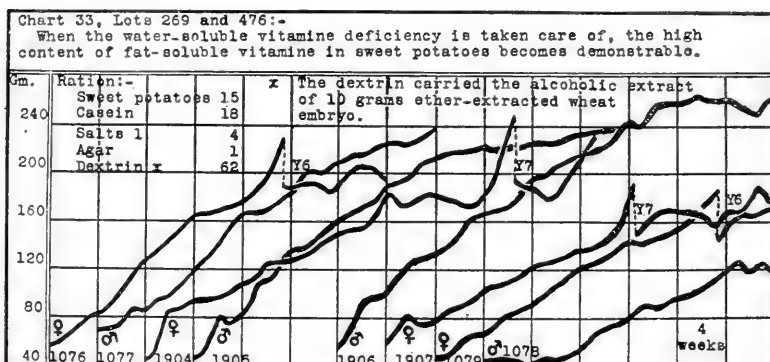

CHART 33. The experimental results of two separate feeding trials indicate that the primary vitamine deficiency in our sweet potato material was the water-soluble vitamine deficiency. When this was corrected by the addition of an alcoholic extract of ether-extracted wheat embryo fairly good growth, together with rearing of the young, became possible. Neither the growth of the original lots nor the growth of the offspring was normal, but nevertheless the performance was remarkable as growth was long continued. Rat 1077 in the 19th week developed an edematous eye and Rat 1078 an inflamed eye. These abnormal conditions were temporary and later entirely disappeared. They were diagnosed as not being caused by a fat-soluble vitamine deficiency and, as the attacks were not of long duration and were not accompanied by great losses in weight, they were taken as being due to trauma. This later appeared entirely justifiable in view of the success in reproduction. Rat 1076 raised four young to an average weight of 59 gm. in 9 weeks, and Rats

1904 and 1907 five young to an average weight of 44 gm. in 7 weeks and 4 days. These must not be taken as instances of satisfactory rearing of young, as their rate of development was only approximately one-half of what it should be; it was remarkable that young were raised at all.

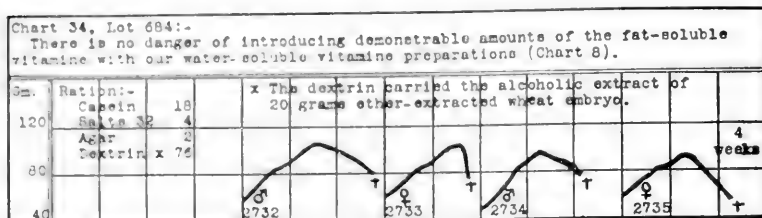

CHART 34. While we had demonstrated once before (Chart 8) that our water-soluble vitamin preparation contains little if any fat-soluble vitamins, the demonstration, on account of the importance of the data just discussed, was here repeated. On a ration containing the alcoholic extract of 20 gm. of ether-extracted wheat embryo as the sole possible source of the fat-soluble vitamins all the rats succumbed within 3 months and all had infected eyes, although Rat 2732 owed its death directly to an abscess on its jaw and Rat 2733 to a pulmonary infection. The results prove that the growth in Lots 269 and 476, Chart 33, could not possibly have been due to the high fat-soluble vitamin content of the water-soluble vitamin extract.

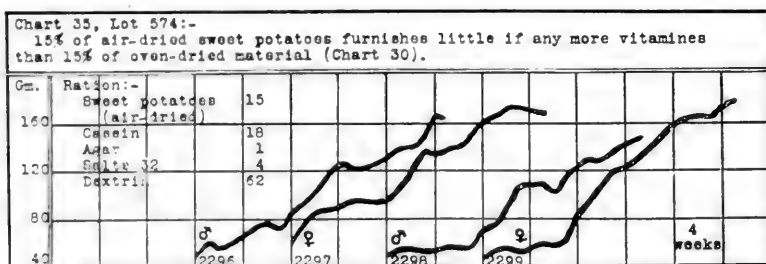

CHART 35. In spite of the data on the stability of the water-soluble vitamins now at hand in the literature, it cannot be taken for granted that the vitamins are left intact in the process of drying where temperatures higher than room temperature are employed. The sweet potatoes used in this and the following two lots were obtained on the local market. They were peeled, then sliced, and dried in an air current at room temperature. On them, at a level of 15 per cent as the source of vitamins, growth was slow and indicated a lack of vitamins as in Lot 477, Chart 30, of the oven-dried material.

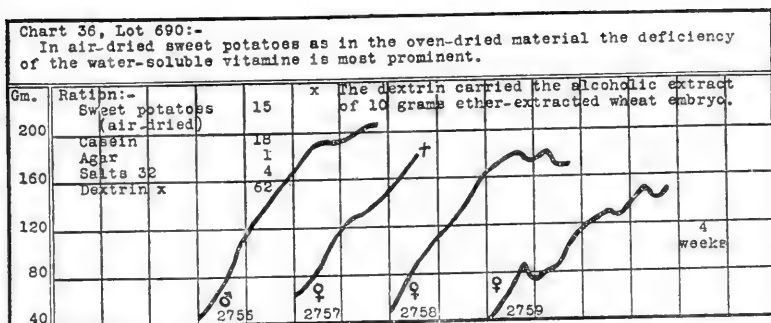

CHART 36. 15 per cent of the air-dried sweet potatoes when fortified with water-soluble vitamine enables more rapid growth to occur than without this addition. The experiment has not yet been concluded, but the indications are that the order of magnitude of the vitamine deficiencies of a vitamine-free ration having its vitamine introduced with small percentages of air-dried sweet potatoes are of the same character as those of the oven-dried material.

CONCLUSION.

From the data of the present series of investigations it is seen that the vitamine relations in roots may be of a widely differing character. With 15 per cent of the diet made up of roots as the source of the fat-soluble vitamine we have in the case of the yellow sweet potato and carrot normal growth and even rearing of the young made possible, but in the case of the rutabaga, dasheen, red beet, parsnip, potato, mangel, and sugar beet complete failure resulted. In fact, in some instances failure at such higher levels as were dried—25 per cent in the case of the mangel and sugar beet and 83 per cent in case of the dasheen—was also observed.

Likewise, from the data here presented—which are representative of a large number of experiments—the conclusion seems warranted that tubers and roots are not necessarily to be classed with food materials grossly deficient in their fat-soluble vitamine content. While in some instances it is true that there is little or no fat-soluble vitamine demonstrable, in other instances there is enough present to warrant their classification with respect to their content of this dietary essential with leafy materials rather than with our cereal grains such as maize, wheat, barley, or oats.

It must not be taken for granted that absolute comparisons of the amounts of the vitamine to be found in different plant materials are possible as our knowledge of the occurrence of the vitamine is too limited. At any rate it is probable that not until we know something of the function of this vitamine in the plant kingdom, or at least know something of its association with specific principles or physiological processes that general statements on the basis of such limited data as here presented will be warranted. The danger of drawing conclusions from limited data is brought out graphically in the case of the experiments carried out on potatoes. In only one out of two instances was the presence of the fat-soluble vitamine demonstrated when different samples were fed at high levels. We believe that this is only one of numerous instances of variation in the natural occurrence of vitamine which later may be easily understood as their physiological rôle is appreciated. We believe, however, that our general conclusions in regard to the especially high fat-soluble vitamine content of carrots and yellow sweet potatoes as compared with red beets, parsnips, rutabagas, sugar beets, potatoes, mangels, and dasheens will not need qualification.

The water-soluble vitamine relations as brought out in our experiments are also worthy of some comment. In the case of the carrot, rutabaga, and dasheen 15 per cent of the material furnished enough of this vitamine for growth. Of sweet potatoes a somewhat larger amount was necessary, but of the sugar beet and mangel, even as much as 25 per cent of the ration gave no evidence of furnishing this compound.

In comparing the relative amounts of fat-soluble vitamine and water-soluble vitamine occurring in the various materials studied it is noteworthy that there is no evident relation between them as measured by the amount required to enable the rat to grow. While in dasheens no fat-soluble vitamine could be demonstrated no matter what the amount fed—though 15 per cent furnished enough water-soluble vitamine—in carrots on the other hand enough of both the fat- and water-soluble vitamine was furnished by an amount equivalent to 15 per cent of the ration. Again, in mangels and sugar beets both vitamins were present in such small amounts, if at all, that they could not be demonstrated when fed at a 25 per cent level. From the standpoint of plant

physiology it is difficult to surmise just what these relations signify, but most certainly it does not appear justifiable to associate generally great physiological activity with an abundance of vitamine.

Acknowledgments and thanks are due to Dr. J. S. Caldwell, Dr. R. A. Young, and Dr. P. H. Dorsett of the Bureau of Plant Industry, Washington, D. C., for cooperation in the experiments to the extent of supplying the authors with dasheens and sweet potatoes suitable for these experiments.

EXPLANATION OF PLATE 1.

FIG. 1. Rat 1916 was raised on a ration which derived its entire content of vitamine, both fat- and water-soluble, from sweet potatoes which made up 60 per cent of it (Chart 32). Started on the ration at 45 gm. September 9, 1918, she weighed 215 gm. June 9, 1919. As seen from the picture she was in excellent nutritive condition just after she had raised the second litter of young.

FIG. 2. Two out of the litter of six young all of which were raised by Rat 1916 on the 60 per cent sweet potato ration as the source of vitamines. When photographed at the age of 5 weeks and 4 days they averaged 53 gm. in weight. Though normally on our stock ration they would have weighed this 12 days sooner, their performance on this restricted ration is none the less remarkable.

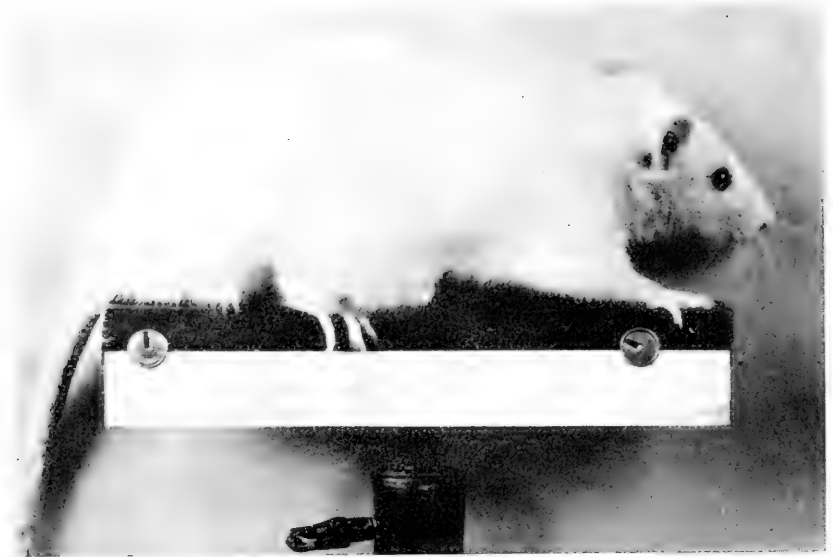

FIG. 1.



FIG. 2.

(Steenbock and Gross: Fat-soluble vitamins. II.)



CHEMOTHERAPEUTIC STUDIES ON ORGANIC COMPOUNDS CONTAINING MERCURY AND ARSENIC.*

BY GEORGE W. RAIZISS, JOHN A. KOLMER, AND JOSEPH L. GAVRON.

(From the Dermatological Research Laboratories, Philadelphia.)

(Received for publication, October 29, 1919.)

The valuable properties of mercury compounds in the treatment of spirochete infections are well known. Prior to the discovery of the dihydrochloride of diaminodioxarsenobenzene, widely known as salvarsan, mercury compounds were practically the only remedies known for syphilis. While the modern therapy of syphilis is primarily based on the use of salvarsan, metallic mercury, and its inorganic and organic derivatives remain important aids in combating the infection. The elaboration of a mercury compound possessing more powerful spirochetocidal properties, also less toxicity for the body than any of the known mercury compounds, is of great importance. Attempts to synthesize such a compound were numerous (1). As yet none of the new organic mercury compounds has shown superior properties in the treatment of syphilis which would make it more useful than any of the old mercury preparations employed for years by physicians.

The researches of Dimroth (2), Pesci (3), Schrauth and Schoeller (4), and others suggest the advisability of dividing organic mercury compounds in three classes.

To one class belong the full complex compounds in which mercury is attached to carbon of two organic compounds as for instance in Pesci's mercury dibenzoic acid:

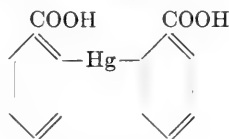

* This work was made possible by funds accruing from the dispensing of arsphenamine.

Fischer (5) and also Müller, Schoeller, and Schrauth (6) demonstrated that mercury compounds of the foregoing type are less toxic, but at the same time therapeutically less active than any other class. The reason probably lies in the fact that mercury is so firmly bound to the carbon atoms as to be almost entirely deprived of its metallic properties. This view is supported by observation that mercury cannot be split off even when these compounds are treated with hydrogen sulfide in boiling hot solution.

To the second group comprising the pseudocomplex compounds, belong mercury salts of organic acids, also compounds where hydrogen of a hydroxyl or amino group is replaced by the metal. They are characterized by the ease with which mercury is split off by the action of diluted solutions of caustic soda or hydrogen sulfide in the cold.

The last and most important group includes the so called half complex mercury compounds in which one valence of the metal is attached to the carbon atom of the benzene ring and the other to an inorganic group such as hydroxyl, halogen, or an acetic acid radical. This group is characterized by a comparative stability.

The firmness with which mercury is bound to the organic compound is decidedly greater in half complex compounds than in pseudocomplex. It varies with different compounds and is probably dependent upon the presence of various other groups in the benzene ring.

It is possible that there is relationship between the firmness of the position of mercury in the organic compound and the therapeutic or germicidal effect. Such a relationship, however, can not yet be established.

Two of the authors, for the past 5 years, have been engaged in a series of chemotherapeutic studies with Dr. Jay Frank Schamberg. Organic mercury compounds were to a considerable extent the subject of these investigations. The half complex compounds were thought to be the most suitable for chemotherapeutic study and a considerable number were prepared. Their chemical and biological properties will be the subject of this and subsequent papers. In this communication we intend to describe a class of aromatic organic arsenical compounds in which mercury was introduced.

It appeared to us particularly interesting to synthesize compounds where both mercury and arsenic were present in the molecule, as the combined effect of these elements, we thought, might be of greater therapeutic value. Only very few organic compounds containing mercury and arsenic have been described in the literature. Practically no data about their biological properties have been given.

We prepared mercurial derivatives of various phenylarsinic acids. Mercury could not be introduced into aromatic compounds containing trivalent arsenic, for instance, in arspenamine, inasmuch as oxidation occurred almost immediately with the resulting formation of metallic mercury.

EXPERIMENTAL.

3-Nitroarsanilic Acid-Mercuric Acetate, No. 76.

10 gm. of 3-nitroarsanilic acid were suspended in about 75 cc. of water and dissolved by the addition of 22 cc. of 15 per cent sodium hydroxide (the amount necessary to form a disodium salt). This was mixed with a solution of 13.0 gm. of mercuric acetate dissolved in 70 cc. of water (12.1 gm. = 1 mol) containing a little acetic acid to prevent the formation of any basic salt. A yellow precipitate was thrown down immediately. The whole was allowed to stand for 48 hours in the cold with vigorous mixing from time to time. Then the precipitate was filtered off, washed thoroughly with water, then methyl alcohol, and finally with ether, and dried in the desiccator over sulfuric acid.

Yield = 15.3 gm. = 77 per cent of the theoretical.

	Nitrogen. <i>per cent</i>	Mercury. <i>per cent</i>	Arsenic. <i>per cent</i>
<i>Analysis.</i> —Calculated.....	5.38	38.46	14.42
Found.....	5.73	38.38	14.52

These results are in agreement with the following formula:

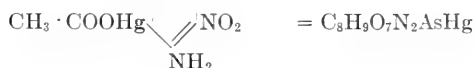
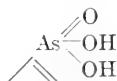

Properties.—A bright yellow powder soluble in very dilute sodium hydroxide on warming. It is slightly soluble in methyl alcohol, insoluble in cold or warm ethyl alcohol, ether, and acetone. Soluble in glacial acetic acid at ordinary temperature, also in 15 per cent acetic acid on warming and in 10 per cent hydrochloric acid.

3-Nitro-4-Hydroxyphenylarsinic Acid-Mercuric Acetate, No. 95.

10 gm. of 3-nitro-4-hydroxyphenylarsinic acid were dissolved using 50 cc. of water and 20 cc. of 15 per cent sodium hydroxide. To the deep yellow solution were added 12.5 gm. of mercuric acetate (12 gm. = 1 mol) in 65 cc. of water and a little acetic acid. A yellow precipitate was formed which was insoluble in 0.5 per cent sodium hydroxide. The whole was heated on a water bath for $1\frac{1}{2}$ to 2 hours when a sample dissolved completely in 0.5 per cent sodium hydroxide, thereby showing the absence of any free mercury ions. After thorough cooling, the precipitate was filtered off, washed thoroughly with water, methyl alcohol, and ether, and then dried in a desiccator over sulfuric acid.

It may be purified by dissolving in dilute sodium hydroxide and reprecipitating with acetic acid.

Yield = 13.5 gm. = 68 per cent of the theoretical.

	Nitrogen. per cent	Mercury. per cent	Arsenic. per cent
<i>Analysis.</i> —Calculated.....	2.69	38.39	14.40
Found.....	{ 2.61	38.05	14.50
	{ 2.82		

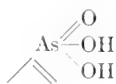

Properties.—A yellow powder soluble in dilute sodium hydroxide forming a yellow solution, insoluble in both cold and warm methyl and ethyl alcohol, ether, acetone, and glacial acetic acid.

3:5-Dinitro-4-Hydroxyphenylarsinic Acid-Mercuric Acetate,
No. 126.

10 gm. of 3:5-dinitro-4-hydroxyphenylarsinic acid were dissolved in 10 cc. of methyl alcohol by warming on a water bath. 12 gm. of mercuric acetate (10.0 gm. = 1 mol) were dissolved in 75 cc. of methyl alcohol with the addition of a few drops of acetic acid, and the two solutions mixed in the cold. The mixture was warmed on the water bath with a reflux condenser for about 10 hours until no free mercury ions could be detected by 0.5 per cent sodium hydroxide.

The precipitate was filtered off, washed thoroughly with methyl alcohol and then with ether, and dried in the desiccator.

Yield = 11.0 gm. = 60 per cent of the theoretical.

	Nitrogen. per cent	Mercury. per cent	Arsenic. per cent
<i>Analysis.</i> —Calculated.....	4.96	35.34	13.25
Found.....	4.72	35.35	13.60

These results correspond with the following formula:

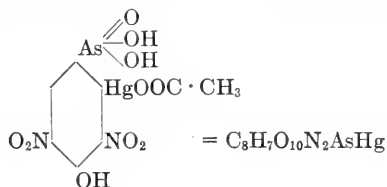

Properties.—A bright yellow powder only partially soluble in dilute sodium hydroxide. A pale yellow turbidity persists. It is insoluble in methyl and ethyl alcohol, ether, and acetone.

3-Amino-4-Hydroxyphenylarsinic Acid-Mercuric Acetate, No. 96.

10 gm. of 3-amino-4-hydroxyphenylarsinic acid were dissolved in 75 cc. of water and 21 cc. of 15 per cent sodium hydroxide at room temperature (because warming an alkaline solution of the above amino compound would oxidize it). A dark brown solution was thus formed. This was mixed with a solution of 14.0 gm. of mercuric acetate (13.6 gm. = 1 mol) dissolved in 70 cc. of water and a little glacial acetic acid. The mixture was kept cooled in ice water.

A light brown precipitate formed immediately. The whole was well shaken for about $\frac{1}{2}$ hour, during which time the color of the precipitate gradually darkened. It was filtered off, washed with water, methyl alcohol, and ether, and dried in the desiccator.

It may be purified by dissolving in dilute sodium hydroxide and reprecipitating with acetic acid.

Yield = 17.5 gm. = 83 per cent of the theoretical.

	Nitrogen. per cent	Mercury. per cent	Arsenic. per cent
<i>Analysis</i> .—Calculated.....	2.85	40.73	15.27
Found.....	2.83	40.60	15.25

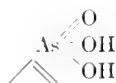

Properties.—A brown powder soluble in dilute sodium hydroxide. This solution splits off metallic mercury within a few minutes which is deposited as a fine, gray powder. It is insoluble in the usual organic solvents, slightly soluble in cold glacial acetic acid and also 10 per cent hydrochloric acid.

3:5-Diamino-4-Hydroxyphenylarsinic Acid-Mercuric Acetate,
No. 125.

10 gm. of 3:5-diamino-4-hydroxyphenylarsinic acid were dissolved in 100 cc. of water and 22 cc. of 15 per cent sodium hydroxide, thereby forming a disodium salt. A brown solution was obtained. This was mixed with a solution of 13.5 gm. of mercuric acetate (13.0 gm. = 1 mol) dissolved in 70 cc. of water and a little acetic acid. The mixture was kept cold by immersing in ice water and was vigorously mixed for about $\frac{1}{2}$ hour, at the end of which time a sample of the precipitate dissolved completely in 0.5 per cent sodium hydroxide. The precipitate was filtered off, washed thoroughly with water, methyl alcohol, and ether, and dried in the desiccator.

It may be purified by dissolving in 1 per cent sodium hydroxide and reprecipitating with dilute acetic acid.

Yield = 13 gm. = 65 per cent of the theoretical.

	Nitrogen. per cent	Mercury. per cent	Arsenic. per cent
<i>Analysis.</i> —Calculated.....	5.53	39.53	14.82
Found.....	6.06	38.87	14.84

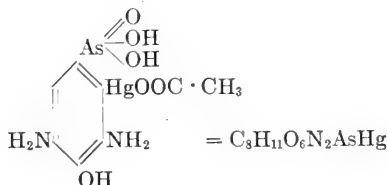

Properties.—A dark brown powder soluble in very dilute sodium hydroxide. The solution on standing splits off metallic mercury. Insoluble in the usual organic solvents. Partially soluble in cold glacial acetic acid. Soluble in 10 per cent hydrochloric acid.

4-Carboxyphenylarsinic Acid- or p-Benzarsinic Acid-Mercuric Acetate, No. 127.

10 gm. of *p*-benzarsinic acid were dissolved in 75 cc. of water and 11.0 cc. of 15 per cent sodium hydroxide by warming on the water bath. This was mixed at ordinary temperature with a solution of 13.5 gm. of mercuric acetate (13.0 gm. = 1 mol) in 70 cc. of water. A white precipitate formed immediately. The whole was warmed on the water bath for about 1 hour, when a sample of the filtrate no longer showed the presence of mercury ions. The precipitate was filtered off, washed thoroughly with water, methyl alcohol, and ether, and dried in the desiccator.

Yield = 13.5 gm. = 67 per cent of the theoretical.

	Mercury. per cent	Arsenic. per cent
<i>Analysis.</i> —Calculated.....	39.68	14.88
Found.....	{ 39.80 39.75	15.13

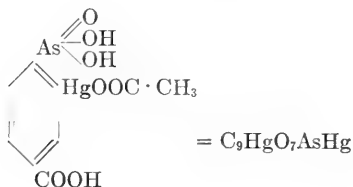

Properties.—A cream-colored powder insoluble in sodium hydroxide, a yellow precipitate being formed. Soluble in dilute hydrochloric acid, concentrated sodium chloride solution, and in glacial acetic acid on warming. Insoluble in hot or cold methyl or ethyl alcohol, ether, and acetone.

Diacetyl-3:5-Diamino-4-Hydroxyphenylarsinic Acid-Mercuric Acetate, No. 97.

10 gm. of diacetyl-3:5-diamino-4-hydroxyphenylarsinic acid were dissolved in 175 cc. of methyl alcohol by warming on the steam bath. The dark brown solution obtained was mixed in the cold with 10 gm. of mercuric acetate (9.6 gm. = 1 mol) dissolved in 60 cc. of methyl alcohol. After shaking for about 20 minutes a dark gray precipitate settled out, which was filtered off and washed thoroughly with methyl alcohol and ether, and dried in a desiccator.

This compound could not be further purified because of its instability. The results obtained for mercury are not quite in accord with the assumed formula. No other formula could be suggested. The nitrogen and arsenic values were found to agree with the assumed formula.

Yield = 15 gm. = 86 per cent of the theoretical.

	Nitrogen. <i>per cent</i>	Mercury. <i>per cent</i>	Arsenic. <i>per cent</i>
<i>Analysis.</i> —Calculated.....	4.75	33.90	12.71
Found.....	4.65	36.40	13.05

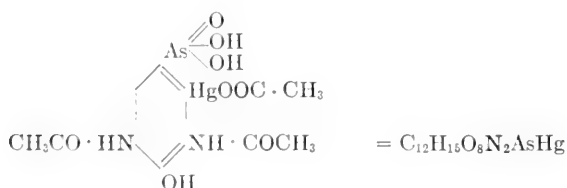

Properties.—A gray powder soluble in dilute sodium hydroxide forming a brown solution. This on standing becomes turbid, and finally metallic mercury is split off. It is insoluble in the usual organic solvents. Partly soluble in cold glacial acetic acid.

3-Bromoarsanilic Acid-Mercuric Acetate, No. 121.

10 gm. of 3-bromoarsanilic acid were dissolved in 100 cc. of water. To this were added 18 cc. of sodium hydroxide and a solution of 11.0 gm. of mercuric acetate (10.5 gm. = 1 mol) in 65 cc. of water and the whole was well mixed. After heating on a steam bath for about 3 hours, no mercury ions could be detected by 0.5 per cent sodium hydroxide. After cooling, the precipitate was filtered, washed with water, methyl alcohol, and ether, and then dried in the desiccator.

Yield = 15 gm. = 80 per cent of the theoretical.

	Nitrogen. per cent	Mercury. per cent	Arsenic. per cent
<i>Analysis.</i> —Calculated.....	2.53	36.10	13.54
Found.....	2.74	36.15	13.52

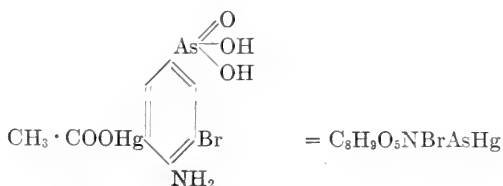

Properties.—A white powder insoluble in the usual organic solvents. Soluble in dilute sodium hydroxide, warm glacial acetic acid, and 10 per cent hydrochloric acid.

3-Bromooxalylarsanilic Acid-Mercuric Acetate, No. 122.

10 gm. of 3-bromooxalylarsanilic acid were dissolved in 150 cc. of water and 15 cc. of sodium hydroxide, to which was added a solution of 9.5 gm. of mercuric acetate (8.6 gm. = 1 mol) dissolved in 60 cc. of water. The mixture was heated on the steam bath for about 2 hours when a sample dissolved completely in sodium hydroxide. The precipitate was filtered, washed with water, ethyl alcohol, and ether, and dried in the desiccator.

Yield = 8.5 gm. = 50 per cent of the theoretical.

	Nitrogen. per cent	Mercury. per cent	Arsenic. per cent
<i>Analysis.</i> —Calculated.....	2.24	31.95	11.98
Found.....	2.19	{ 32.30 32.37	11.65

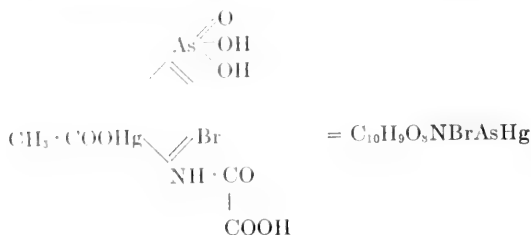

Properties.—A white powder insoluble in organic solvents and acetone. Soluble in very dilute sodium hydroxide. If this solution is allowed to stand metallic mercury splits off.

Biological Experiments.

These new compounds were subject to a series of routine biological tests for (a) antiseptic and germicidal activity for staphylococci, *Bacillus typhosus*, and a spore-bearing microorganism *Bacillus anthracis*, (b) toxicity for white rats, and (c) for trypanocidal activity against infections with *Trypanosoma equiperdum* in white rats.

Results of Antiseptic or Bacteriostatic Tests.—In conducting these tests varying dilutions of solutions of the different compounds in amounts of 1 cc. were placed in sterile test-tubes and further diluted by the addition of 5 cc. of nutrient broth and seeding with 0.5 cc. of filtered, 24 hour broth cultures of the respective microorganisms. Each series of tubes was observed over a period of 5 days and the highest final dilution showing retardation of growth was recorded as the antiseptic or bacteriostatic strength of the compound. Subcultures or solid media have regularly shown that these antiseptic values do not correspond to the germicidal activity inasmuch as viable microorganisms may be recovered, but the technique is very simple, serves to bring out the finer differences in antiseptic values of the different compounds, and has proved of much value in former studies with compounds of this class for determining their influence upon bacterial activity.

The results of tests with this series of new compounds and with mercuric chloride and mercurphen are summarized in Table I and have shown the following.

1. As a general rule a higher antiseptic activity was displayed against staphylococci than *Bacillus typhosus*. This is particularly true of sodium oxy-mercury orthonitrophenolate (mercuropen) as previously described (7) and is apparent with several of the new compounds included in this series; namely, Nos. 76, 95, 97, 121, and 122. Compounds 96 and 125 did not show this peculiar and interesting superior antiseptic activity for staphylococci.

2. Two of these compounds, namely Nos. 97 and 121, have also displayed striking antiseptic activity for the bacilli and spores of anthrax, which is a distinguishing characteristic of mercuropen.

TABLE I.

Results of Antiseptic or Bacteriostatic Tests of Compounds in a Menstruum of Nutrient Broth.

Substance.	Mercury.	Highest antiseptic solution for		
		<i>Staphylococcus aureus.</i>	<i>Bacillus typhosus.</i>	<i>Bacillus anthracis.</i>
	<i>per cent</i>			
Bichloride Hg.	74	1: 600,000	1: 360,000	1: 600,000
Mercurophen.	53	1: 2,400,000	1: 360,000	>1: 2,400,000
No. 76.	38.3	1: 420,000	1: 180,000	1: 180,000
" 95.	38	1: 180,000	1: 42,000	1: 36,000
" 96.	40.6	1: 60,000 (?)	1: 60,000	1: 54,000
" 97.	36.4	1: 420,000	1: 180,000	>1: 2,000,000
" 121.	36.1	1: 480,000	1: 180,000	1: 600,000
" 122.	32.3	1: 540,000	1: 180,000	1: 180,000
" 125.	38.8	1: 360,000	1: 240,000	1: 120,000

Additional tests with compounds of this series which could be prepared in sufficiently concentrated solutions, have shown that a marked reduction in antiseptic activity occurs in the presence of large amounts of protein, as when the tests are conducted in a menstruum of serum. The results of tests shown in Table II were obtained by adding to varying dilutions of the compounds in water in amounts of 1 cc. an equal amount of sterile human serum and seeding with 0.05 cc. of filtered, 24 hour broth cultures of *Staphylococcus aureus*; the results indicate the highest antiseptic or bacteriostatic activities of the various compounds in a menstruum of 50 per cent human serum.

TABLE II.

Results of Antiseptic or Bacteriostatic Tests of Compounds in a Menstruum of Human Serum for *Staphylococcus aureus*.

Substance.	Mercury.	Highest antiseptic solution for <i>Staphylococcus aureus</i> .
	per cent	
Bichloride Hg.....	74	1:5,400
Mereurophen.....	53	1:6,000
No. 76.....	38.3	1:6,000
" 96.....	40.6	1:4,800
" 121.....	36.1	1:6,000
" 123.....	32.3	1:4,800
" 125.....	38.8	1:5,400

Results of Toxicity Tests.—These tests were conducted by injecting white rats intravenously with varying doses of the new compounds per kilo of body weight and so prepared that the dose for each animal was contained in exactly 1 cc. The injections were made in a saphenous vein and at the rate of 1 cc. per minute. Following injection the animals were observed for a period of 2 weeks. The results of these tests are shown in Table III and summarized in Table IV with the inclusion of mercuric chloride and mereurophen for purposes of comparison.

A few compounds were also tested by intramuscular injection into the muscles of the thigh of white rats and the results with Nos. 96 and 97 are shown in Table V.

Previous studies in these laboratories with ordinary mercurial compounds (8) have shown that toxicity is somewhat proportional to the content in mercury and this condition is apparently true of these new compounds as judged by the highest tolerated doses at the end of a 10 day period of observation. An exception to this general rule is apparent with mereurophen which is generally borne by experimental animals in doses higher than expected according to the percentage of mercury present and to which attention has been drawn in the investigations previously mentioned (7).

Results of Trypanocidal Tests.—These experiments were conducted by infecting white rats with approximately known numbers (9) of a virulent strain of *Trypanosoma equiperdum* by intraperitoneal or subcutaneous injection 24 hours before the intravenous injection of the compounds in varying dosage per kilo of

TABLE III.

Results of Toxicity Tests by Intravenous Injection in Rats.

Compound No.	Name of compound.	Mercury.	Weight of rat.		Results in days.																	
			per cent	gm.	mg.	Dose per kilo.	1	2	3	4	5	6	7	8	9	10	11	12	13	14		
95	3-Nitro-4-hydroxy-phenylarsinic acid-mercuric acetate.	38.05	79	10	*																	
			117	8																		
			78	4		D																
			180	2																		
96	3-Amino-4-hydroxy-phenylarsinic acid-mercuric acetate.	40.6	160	30	D																	
			195	20	D																	
			130	10			D															
			185	5																		
97	Diacetyl-3:5-diamino-4-hydroxy-phenylarsinic acid-mercuric acetate.	36.4	107	10						D												
			98	8					D													
			138	6																		
			114	2																		
121	3-Bromoarsanilic acid-mercuric acetate.	36.15	140	30	D																	
			350	20	D																	
			120	10			D															
			185	5																		
122	3-Bromooxalyl-arsanilic acid-mercuric acetate.	32.3	120	30	D																	
			130	20	D																	
			160	10		D																
			115	5																		
125	3:5-Diamino-4-hydroxyphenyl-arsinic acid-mercuric acetate.	38.87	165	30				D														
			155	20	D																	
			100	10				D														
			130	5																		

* Died.

body weight; each dose was prepared separately and contained in 1 cc. for each animal. Numerous controls were infected at the same time and in the same manner but were not injected with the compounds. Following the injections of drugs the blood of

each animal was examined daily for trypanosomes by direct microscopical examination until death occurred.

The results of these therapeutic tests are shown in Tables VI and VII. As previous studies have shown (10) mercurial compounds cannot be given in sufficient dosage to exert more than a minor and temporary influence upon experimental trypanosomiasis with this strain of trypanosomes and similar results were observed with the new compounds herein described.

TABLE VI.

*Results of Therapeutic Tests with Trypanosoma equiperdum.**

Compound No.	Name of compound.	No.	Weight of rat.		Dose per kilo.	Results in days.						
			gm.	mg.		1	2	3	4	5	6	7
95	3-Nitro-4-hydroxyphenylarsinic acid-mercuric acetate.	1	90	12	—	+	+	+	+	+	+	D
		2	87	10	—	+	+	+	+	+	+	D
		3	84	8	D							
		4	85	6	—	+	+	+	+	+	+	D
96	3-Amino-4-hydroxyphenylarsinic acid-mercuric acetate.	5	145	8	—	+	+	D				
		6	220	4	—	+	+	+	D			
		7	210	2	—	+	+	+	D			
Controls.	0	8	115	0	Few.	+	+	+	+	+	D	
		9	144	0	"	+	+	+	+	+	+	D
		10	114	0	"	+	+	+	+	+	+	D
		11	140	0	"	+	+	+	+	+	+	D

* Rats infected by intraperitoneal injection of 180,000 trypanosomes 24 hours before the intravenous injection of the drugs.

Entirely different results may be expected in tests with rabbits infected with *Treponema pallidum* and we hope to be able to report later on this phase of the problem, when these laborious experiments are sufficiently concluded to permit of drawing comparisons and conclusions.

Further tests conducted with a new technique previously described (11), consisting in mixing in test-tubes the blood of rats showing the presence of very large numbers of these trypanosomes with an equal quantity of solutions of the new compounds

and testing for trypanocidal activity by injecting portions of the mixture intraperitoneally in rats after standing for varying periods of time at 37°C. in a water bath, have shown a high degree of trypanocidal activity on the part of several of these compounds; the results observed with two of them (Nos. 95 and 97) are shown in Table VIII.

TABLE VII.

*Results of Therapeutic Tests with Trypanosoma equiperdum.**

Compound No.	Name of compound.	Weight of rat.		Dose per kilo.	Results in days.				
		gm.	mg.		1	2	3	4	5
95	3-Nitro-4-hydroxyphenylarsinic acid-mercuric acetate.	185	2	Few.	+	+	+		D
		145	1	"	+	+	+		D
		140	$\frac{1}{2}$	"	+				D
97	Diacetyl-3:5-diamino-4-hydroxyphenylarsinic acid-mercuric acetate.	180	2	"	+	+			D
		175	1	"	+				D
		175	$\frac{1}{2}$	"	+	+			D
121	3-Bromoarsanilic acid-mercuric acetate.	220	2	"	+	+			D
		190	1	"	+	+	+		D
		185	$\frac{1}{2}$	"	+	+	+		D
122	2-Bromooxalyarsanilic acid-mercuric acetate.	160	2	"	+				D
		200	1	"	+	+	+		D
		210	$\frac{1}{2}$	"	+	+	+		D
Controls.		170	0	"	+	+	+		D
		160	0	+	+	+			D
		175	0	+	+	+			D

* Rats infected by subcutaneous injection of 800,000 trypanosomes 24 hours before the intravenous injection of the drugs.

The technique is quite delicate and serves to show whether or not compounds too toxic for administration in sufficient amounts to influence experimental trypanosomiasis in living animals possess trypanocidal activity as tested by this combined *in vitro-vivo* method.

TABLE VIII.

Results of Trypanocidal Tests with the Combined *in Vitro-Vivo* Technique.

Compound No.	Name of compound.	Weight of rat.	Dose.*	Results in days.															
				1	2	3	4	5	6	7	8	9	10	15					
95	3-Nitro-4-hydroxy-phenylarsinic acid-mercuric acetate.	gm.	mg.																
		84	0.001	-	-	-	-	D											
		77	0.0005	-	-	-	-	D											
		55	0.00025	-	-	-	-	D											
		114	0.000125	-	-	-	-	D											
		63	0.000625	-	-	-	-	-	-	-	-	-	-	-	-	-	-	-	
97	Diacetyl-3:5-diamino-4-hydroxy-phenylarsinic acid-mercuric acetate.	81	0.001	-	-	-	-	-	-	-	-	-	-	-	-	-	-	-	
		122	0.0005	-	-	-	-	-	-	-	-	-	-	-	-	-	-	-	-
		82	0.00025	-	-	-	-	-	-	-	-	-	-	-	-	-	-	-	-
		102	0.000125	-	-	-	-	-	-	-	-	-	-	-	-	-	-	-	-
		92	0.0000625	-	-	-	-	+	+	+	D								
Controls.	0	65	0	+	+	+	+	+	D										
		62	0	-	+	+	+	+	D										
		60	0	-	+	+	+	+	D										

* Final amount of drug acting upon the trypanosomes contained in the blood of rats.

Conclusions.

1. The new compounds herein described possess less antibacterial activity than mercuric chloride but are likewise lower in content of mercury; a number of these compounds have shown a particularly increased activity against staphylococci and a few against a spore-forming bacillus, namely *Bacillus subtilis*, as compared with mercuric chloride.

2. The antibacterial activities of the new compounds tested showed a marked reduction in a menstruum rich in serum proteins.

3. The toxicity of these compounds for white rats bears a general relation to their content in mercury.

4. The new compounds possess trypanocidal activity as tested by an *in vitro-vivo* method but cannot be administered to living animals in sufficient amounts to appreciably influence the course of experimental trypanosomiasis.

Methods of Analysis.

Nitrogen was determined by the ordinary Kjeldahl method. In the cases of compounds containing nitro groups the latter were first reduced. Mercury and arsenic were determined from the same sample. 0.2 gm. was decomposed by 25 cc. of concentrated sulfuric acid, diluted with water, and the mercury and arsenic were precipitated together by hydrogen sulfide. After filtering and washing, the arsenic sulfide was dissolved in ammonia and the arsenic determined gravimetrically in the usual way as magnesium pyroarsenate. The mercuric sulfide was washed successively with methyl alcohol, carbon bisulfide, and acetone, dried, and weighed. The washing with organic solvents, etc. was repeated until the weight of the mercuric sulfide remained constant.¹

Stability.

In order to determine the degree of firmness with which the mercury was attached to the nuclear carbon, we devised the following method. 100 mg. of the compound are dissolved in a small quantity of dilute sodium hydroxide in a 25 cc. glass-stoppered cylinder and dilute acetic acid added drop by drop until the precipitate, which forms, just barely redissolves. The solution is diluted with water up to 25 cc., 5 cc. of 5 per cent neutral ammonium sulfide are introduced, and the mixture is shaken. The time required for the complete precipitation of mercuric sulfide is noted. If this precipitate does not come down within 30 minutes the compound is regarded as being unaffected. The mixture is then heated to 80°C. and maintained at this temperature, noting the time of the precipitation of mercury. If the result is negative after $\frac{1}{2}$ hour, a new solution of the compound is made up and treated this time with hydrogen sulfide, first at ordinary temperature, then at 80°C., and finally at its boiling temperature if necessary. None of the compounds described in this article required treatment with hydrogen sulfide. The results obtained are given in Table IX.

¹ This method of analysis was suggested to us by Dr. W. Jacobs and Dr. M. Heidelberger for which we take this occasion to express our appreciation.

TABLE IX.

Compound.	Ammonium sulfide in cold.	Ammonium sulfide at 80° C.
3-Nitroarsanilic acid-mercuric acetate.	Precipitated immediately.	
3-Nitro-4-hydroxyphenylarsinic acid-mercuric acetate.	Precipitated in 30 min.	
3:5-Dinitro-4-hydroxyphenylarsinic acid-mercuric acetate.	Precipitated immediately.	
3-Amino-4-hydroxyphenylarsinic acid-mercuric acetate.	Partial precipitation.	Complete after 19 min.
3:5-Diamino-4-hydroxyphenylarsinic acid-mercuric acetate.	Slight precipitate.	Complete precipitation in $\frac{1}{2}$ hr.
Diacetyl-3:5-diamino-4-hydroxyphenylarsinic acid-mercuric acetate.	Precipitated immediately.	
<i>p</i> -Benzarsenic acid-mercuric acetate.	" "	
3-Bromoarsanilic acid-mercuric acetate.	" "	
3-Bromooxalylarsanilic acid-mercuric acetate.	" "	

SUMMARY.

1. The presence of the arsenic acid group in the molecule of organic compounds described in this paper apparently does not interfere with the entrance of the mercury group. The half complex compounds thus formed are characterized by a comparative stability in alkaline solution. The splitting off of metallic mercury occurs only in compounds containing an amino group which has also been frequently observed in non-arsenical compounds.

2. The process of formation of the organic arsenical mercury compounds and their chemical properties do not differ substantially from organic mercury compounds containing no arsenic acid group.

3. The toxic effect on the animal body as it appeared to us is mainly caused by the mercury group. The arsenic acid group neither increases nor decreases the toxicity of the compounds.

4. To our disappointment, the curative influence of these new compounds in experimental trypanosomiasis and also the germicidal effect *in vitro* were not superior to the ordinary organic mercury compounds.

5. As in every other chemotherapeutic investigation the apparently negative therapeutic results with the compounds herein described cannot be accepted as definitely characteristic for the arsenical mercury compounds. Our studies were limited to a comparatively small number of compounds and further studies might result in the discovery of a powerful trypanocidal or germicidal containing both mercury and arsenic.

BIBLIOGRAPHY.

1. Schamberg, J. F., Kolmer, J. A., and Raiziss, G. W., *Am. J. Syph.*, 1917, i, 4-8.
2. Dimroth, O., *Ber. chem. Ges.*, 1898, xxxi, 2154.
3. Pesci, L., *Chem. Zentr.*, 1901, 1081.
4. Schrauth, W., and Schoeller, W., *Biochem. Z.*, 1911, xxxii, 509.
5. Fischer, E., *Ber. chem. Ges.*, 1907, xl, 386.
6. Müller, F., Schoeller, W., and Schrauth, W., *Biochem. Z.*, 1911, xxxiii, 381.
7. Schamberg, J. F., Kolmer, J. A., and Raiziss, G. W., *J. Infect. Dis.*, 1919, xxiv, 547.
8. Schamberg, J. F., Kolmer, J. A., and Raiziss, G. W., *J. Cutan. Dis.*, 1915, xxiii, 819.
9. Kolmer, J. A., *J. Infect. Dis.*, 1915, xvii, 79.
10. Schamberg, J. F., Kolmer, J. A., and Raiziss, G. W., *Am. J. Syph.*, 1917, i, 1.
11. Kolmer, J. A., Schamberg, J. F., and Raiziss, G. W., *J. Infect. Dis.*, 1917, xx, 10.

INDEX TO VOLUME XL.

- A**CID, carbonic, and carbonates
in cow's milk, 335
—, glycerophosphoric, of cephalin,
1
—, guanylic, crystalline, 171
—, lactic, influence upon metab-
olism, 79
—, *p*-nitrophenylacetic, in the or-
ganism of fowl, dog, and man, 17
—, phenylacetic, toxicity, 259
—, uridinphosphoric, crystalline
salts of, 395
—, yeast nucleic, structure, 415
Acidosis, relation of creatinuria.
Elimination of ingested crea-
tine and creatinine, 199
Acids, amino-, and protein hydrol-
sates, action of furfural and
dextrose on, 131
—, aromatic, comparative metab-
olism, 17
Alkaline reserve, effect of hemor-
rhage, 29
— of the blood and scurvy,
effects of malt and malt ex-
tracts, 243
ALLEN, E. R., and DAVISSON, B. S.
On the relative accuracy of
colorimetric and titrimetric
procedures for determining ni-
trogen as ammonia, 183
Amino-acids and protein hydrol-
sates, action of furfural and
dextrose on, 131
Ammonia hydrolysis of yeast nu-
cleic acid, 415
—, relative accuracy of colori-
metric and titrimetric proce-
dures for determining nitrogen,
183
Antineuritic vitamine and water-
soluble growth-promoting vita-
mine, identity of, 399
Antiscorbutic value of the banana,
91
Aromatic acids, comparative me-
tabolism, 17
Arsenic and mercury, chemothera-
peutic studies on organic com-
pounds containing, 533
ATKINSON, H. V., and LUSK,
GRAHAM. Animal calorimetry.
Sixteenth paper. The in-
fluence of lactic acid upon
metabolism, 79
BAKER, JOHN C., and VAN SLYKE,
LUCIUS L. A method for the
determination of the keeping
quality of milk, 373
— and —. — — — —
preliminary detection of abnor-
mal milk based on the hydrogen
ion concentration, 357
—. See VAN SLYKE and BAKER,
335, 345
Banana, antiscorbutic value, 91
—, nutritive value, 449
Bean, Chinese velvet, *Stizolobium*
niveum, hydrolysis of stizolobin,
the globulin of, 435
BENEDICT, STANLEY R. See SU-
GIURA and BENEDICT, 449
BLATHERWICK, B. R. See MEIGS,
BLATHERWICK, and CARY, 469
Blood, activity of lung extract, as
compared to extracts of other
tissues, in inducing coagula-
tion, 425

- Blood, alkaline reserve of, and scurvy, effects of malt and malt extracts, 243
 —, determination of carbon monoxide, 103
 —, — — catalase, 127
 — regeneration, studies, 29, 63
 — volume, determination by the carbon monoxide method, 109
- BODANSKY, MEYER. A note on the determination of catalase in blood, 127
- BUELL, MARY V. Studies of blood regeneration. I. Effect of hemorrhage on alkaline reserve, 29. II. Effect of hemorrhage on nitrogen metabolism, 63
- C**ALCIUM and phosphorus metabolism of dairy cows, further contributions to the physiology of, 469
- Calorimetry, animal, 79
- Carbon monoxide, determination in blood, 103
 — — method, determination of blood volume, 109
- Carbonates and carbonic acid in cow's milk, 335
- Carbonic acid and carbonates in cow's milk, 335
- CARY, C. A. See MEIGS, BLATHERWICK, and CARY, 469
- Catalase, determination in blood, 127
- Cephalin, glycerophosphoric acid of, 1
- Chemotherapeutic studies on organic compounds containing mercury and arsenic, 533
- Coagulation of blood, activity of lung extract, as compared to extracts of other tissues, in inducing, 425
 — — milk by heat, 137
- COLE, W. C. C. See McCLENDON, COLE, ENGSTRAND, and MIDDLEKAUFF, 243
- Colorimetric and titrimetric procedures for determining nitrogen as ammonia, relative accuracy, 183
- Compounds, organic, containing mercury and arsenic, chemotherapeutic studies, 533
- Creatine and creatinine, elimination of ingested. Relation of creatinuria to acidosis, 199
 —, urinary, relation of protein intake, 215
- Creatinine and creatine, elimination of ingested. Relation of creatinuria to acidosis, 199
- Creatinuria in infants, 199, 215
 —, relation to acidosis. Elimination of ingested creatine and creatinine, 199
- Crystalline guanlylic acid, 171
 — salts of uridinphosphoric acid, 395
- D**AVISSON, B. S. See ALLEN and DAVISSON, 183
- Determination of blood volume by the carbon monoxide method, 109
 — — carbon monoxide in blood, 103
 — — catalase in blood, 127
 — — keeping quality of milk, 373
 — — nitrogen as ammonia, relative accuracy of colorimetric and titrimetric procedures, 183
- Dextrose and furfural, action on amino-acids and protein hydrolates, 131
- Diabetes, experimental, action of intravenous injections of pancreas emulsions, 153

- DOWELL, C. T., and MENAUL, PAUL. The action of furfural and dextrose on amino-acids and protein hydrolsates, 131
- EMULSIONS**, pancreas, action of intravenous injections in experimental diabetes, 153
- ENGSTRAND, O. See McCLENDON, COLE, ENGSTRAND, and MIDDLEKAUFF, 243
- Extract, lung, activity, as compared to extracts of other tissues, in inducing coagulation of the blood, 425
- Extraction and concentration of the water-soluble vitamine from brewers' yeast, 383
- Extracts, malt, and malt, effects on scurvy and the alkaline reserve of the blood, 243
- FAT**-soluble vitamine, 501
- — — content of roots, together with some observations on their water-soluble vitamine content, 501
- Furfural and dextrose, action on amino-acids and protein hydrolsates, 131
- GAMBLE**, JAMES L., and GOLDSCHMIDT, SAMUEL. A study of creatinuria in infants. I. Relation of creatinuria to acidosis. The elimination of ingested creatine and creatinine, 199. II. Relation of protein intake to urinary creatine, 215
- GAVRON, JOSEPH L. See RAIZISS, KOLMER, and GAVRON, 533
- Globulin of the Chinese velvet bean, *Stizolobium niveum*, hydrolysis of stizolobin, 435
- Glycerophosphoric acid of cephalin, 1
- GOLDSCHMIDT, SAMUEL. See GAMBLE and GOLDSCHMIDT, 199, 215
- GROSS, E. G. See STEENBOCK and GROSS, 501
- Growth-promoting water-soluble vitamine and the antineuritic vitamine, identity of, 399
- Guanylic acid, crystalline, 171
- HARDING**, VICTOR JOHN, and YOUNG, ELRID G. Placental feeding and purine metabolism, 227
- HART, E. B. See SOMMER and HART, 137
- Heat coagulation of milk, 137
- HELFAND, MAX. See SHERWIN and HELFAND, 17
- Hemorrhage, effect on alkaline reserve, 29
- , —, — — — nitrogen metabolism, 63
- Hydrogen ion concentration, method for preliminary detection of abnormal milk, 357
- Hydrolsates, protein, and amino-acids, action of furfural and dextrose on, 131
- Hydrolysis, ammonia, of yeast nucleic acid, 415
- of stizolobin, the globulin of the Chinese velvet bean, *Stizolobium niveum*, 435
- IKEGUCHI**, TAKEO. A new sterol, 175
- Infants, creatinuria in, 199, 215
- Injections, intravenous, of pancreas emulsions in experimental diabetes, 153
- Intravenous injections of pancreas emulsions in experimental diabetes, 153
- JOHNS**, CARL O. See JONES and JOHNS, 435

- JONES, D. BREESE, and JOHNS, CARL O. The hydrolysis of stizolobin, the globulin of the Chinese velvet bean, *Stizolobium niveum*, 435
- K**ENDALL, E. C., and OSTERBERG, A. E. The chemical identification of thyroxin. Second paper, 265
- KENNARD, K. SELLERS. See SHERWIN and KENNARD, 259
- KLEINER, ISRAEL S. The action of intravenous injections of pancreas emulsions in experimental diabetes, 153
- KOLMER, JOHN A. See RAIZISS, KOLMER, and GAVRON, 533
- L**ACTIC acid, influence upon metabolism, 79
- LEVENE, P. A., and ROLF, IDA P. Cephalin. VII. The glycerophosphoric acid of cephalin, 1.
- . Crystalline guanylic acid, 171
- . — salts of uridinphosphoric acid, 395
- . The structure of yeast nucleic acid. IV. Ammonia hydrolysis, 415
- LEWIS, HOWARD B. The antiscorbic value of the banana, 91
- Lung extract, activity, as compared to extracts of other tissues, in inducing coagulation of the blood, 425
- LUSK, GRAHAM. See ATKINSON and LUSK, 79
- M**ALT and malt extracts, effects on scurvy and the alkaline reserve of the blood, 243
- extracts and malt, effects on scurvy and the alkaline reserve of the blood, 243
- McCLENDON, J. F., COLE, W. C. C., ENGSTRAND, O., and MIDDLEKAUFF, J. E. The effects of malt and malt extracts on scurvy and the alkaline reserve of the blood, 243
- MEIGS, EDWARD B., BLATHERWICK, N. R., and CARY, C. A. Further contributions to the physiology of phosphorus and calcium metabolism of dairy cows, 469
- MENAU, PAUL. See DOWELL and MENAU, 131
- Mercury and arsenic, chemotherapeutic studies on organic compounds containing, 533
- Metabolism, comparative, of certain aromatic acids, 17
- , influence of lactic acid, 79
- , nitrogen, effect of hemorrhage, 63
- , phosphorus and calcium, of dairy cows, further contributions to the physiology of, 469
- , purine, and placental feeding, 227
- Method, carbon monoxide, determination of blood volume, 109
- for determination of keeping quality of milk, 373
- — preliminary detection of abnormal milk based on hydrogen ion concentration, 357
- Methods, colorimetric and titrimetric, relative accuracy for determining nitrogen as ammonia, 183
- MIDDLEKAUFF, J. E. See McCLENDON, COLE, ENGSTRAND, and MIDDLEKAUFF, 243
- Milk, abnormal, method for preliminary detection based on the hydrogen ion concentration, 357
- cow's, carbonic acid and carbonates in, 335

- Milk, freshly-drawn, conditions causing variation in reaction, 345
 —, heat coagulation, 137
 —, method for determination of keeping quality, 373
- MILLS, C. A. The activity of lung extract, as compared to extracts of other tissues, in inducing coagulation of the blood, 425
- MITCHELL, H. H. On the identity of the water-soluble growth-promoting vitamine and the antineuritic vitamine, 399
- NITROGEN** as ammonia, relative accuracy of colorimetric and titrimetric procedures for determining, 183
 — metabolism, effect of hemorrhage, 63
p-Nitrophenylacetic acid in the organism of fowl, dog, and man, 17
 Nucleic acid, yeast, structure, 415
 Nutritive value of the banana, 449
- OSBORNE**, THOMAS B., and WAKEMAN, ALFRED J. Extraction and concentration of the water-soluble vitamine from brewers' yeast, 383
- OSTERBERG, A. E. See KENDALL and OSTERBERG, 265
- PANCREAS** emulsions, action of intravenous injections in experimental diabetes, 153
- Phenylacetic acid, toxicity, 259
- Phosphorus and calcium metabolism of dairy cows, further contributions to the physiology of, 469
- Placental feeding and purine metabolism, 227
- Protein hydrosates and amino-acids, action of furfural and dextrose on, 131
- Protein intake, relation to urinary creatine, 215
- Purine metabolism and placental feeding, 227
- RAIZISS**, GEORGE W., KOLMER, JOHN A., and GAVRON, JOSEPH L. Chemotherapeutic studies on organic compounds containing mercury and arsenic, 533
- Regeneration, blood, studies, 29, 63
- ROLF, IDA P. See LEVENE and ROLF, 1
- SALTS**, crystalline, of uridinphosphoric acid, 395
- SALVESEN, HARALD A. See VAN SLYKE and SALVESEN, 103
 —. The determination of blood volume by the carbon monoxide method, 109
- Scurvy and alkaline reserve of the blood, effects of malt and malt extracts, 243
- SHERWIN, CARL P., and HELFAND, MAX. Comparative metabolism of certain aromatic acids. III. Fate of *p*-nitrophenylacetic acid in the organism of fowl, dog, and man, 17
 — and KENNARD, K. SELLERS. Toxicity of phenylacetic acid, 259
- SOMMER, H. H., and HART, E. B. The heat coagulation of milk, 137
- STEENBOCK, H., and GROSS, E. G. Fat-soluble vitamine. II. The fat-soluble vitamine content of roots, together with some observations on their water-soluble vitamine content, 501
- Sterol, new, 175
- Stizolobin, the globulin of the Chinese velvet bean, *Stizolobium niveum*, hydrolysis, 435

- Stizolobium nireum*, the Chinese velvet bean, hydrolysis of stizolobin, the globulin of, 435
- SUGIURA, KANEMATSU, and BENE-DICT, STANLEY R. The nutritive value of the banana. II, 449
- THYROXIN**, chemical identification, 265
- Tissues, extracts as compared with lung extract, in inducing coagulation of the blood, 425
- Titrimetric and colorimetric procedures for determining nitrogen as ammonia, relative accuracy, 183
- Toxicity of phenylacetic acid, 259
- URIDINPHOSPHORIC** acid, crystalline salts of, 395
- Urinary creatine, relation of protein intake, 215
- VAN SLYKE**, DONALD D., and SALVESEN, HARALD A. The determination of carbon monoxide in blood, 103
- VAN SLYKE**, LUCIUS L., and BAKER, JOHN C. Carbonic acid and carbonates in cow's milk, 335
- and —. Conditions causing variation in the reaction of freshly-drawn milk, 345
- . See BAKER and VAN SLYKE, 357, 373
- Vitamine, antineuritic, and water-soluble growth-promoting vitamine, identity of, 399
- , fat-soluble, 501
- , —, content of roots, together with some observations on their water-soluble content, 501
- , water-soluble, content, the fat-soluble vitamine content of roots, together with some observations on, 501
- , —, extraction and concentration from brewers' yeast, 383
- , — growth-promoting, and the antineuritic vitamine, identity of, 399
- WAKEMAN**, ALFRED J. See OSBORNE and WAKEMAN, 383
- Water-soluble growth-promoting vitamine and the antineuritic vitamine, identity of, 399
- vitamine content, the fat-soluble vitamine content of roots, together with some observations on, 501
- —, extraction and concentration from brewers' yeast, 383
- YEAST**, brewers', extraction and concentration of water-soluble vitamine, 383
- nucleic acid, structure, 415
- YOUNG**, ELRID G. See HARDING and YOUNG, 227

T

THE JOURNAL

OF

BIOLOGICAL CHEMISTRY

FOUNDED BY CHRISTIAN A. HERTER AND SUSTAINED IN PART BY THE CHRISTIAN A. HERTER
MEMORIAL FUND

EDITED BY

H. D. DAKIN, New York, N. Y. LAFAYETTE B. MENDEL, New Haven, Conn.
E. K. DUNHAM, New York, N. Y. A. N. RICHARDS, Philadelphia, Pa.
DONALD D. VAN SLYKE, New York, N. Y.

WITH THE COLLABORATION OF

J. J. ABEL, Baltimore, Md.	P. A. LEVENE, New York, N. Y.
STANLEY R. BENEDICT, New York, N. Y.	JACQUES LOEB, New York, N. Y.
R. H. CHITTENDEN, New Haven, Conn.	A. S. LOEVENHART, Madison, Wis.
OTTO FOLIN, Boston, Mass.	GRAHAM LUSK, New York, N. Y.
WILLIAM J. GIES, New York, N. Y.	E. V. McCOLLUM, Baltimore, Md.
L. J. HENDERSON, Cambridge, Mass.	A. B. MACALLUM, Toronto, Canada.
REID HUNT, Boston, Mass.	J. J. R. MACLEOD, Cleveland, Ohio.
ANDREW HUNTER, Toronto, Canada.	JOHN A. MANDEL, New York, N. Y.
W. A. JACOBS, New York, N. Y.	A. P. MATHEWS, Chicago, Ill.
WALTER JONES, Baltimore, Md.	F. G. NOVY, Ann Arbor, Mich.
THOMAS B. OSBORNE, New Haven, Conn.	
T. BRAILSFORD ROBERTSON, Adelaide, Australia.	
P. A. SHAFFER, St. Louis, Mo.	
A. E. TAYLOR, Philadelphia, Pa.	
F. P. UNDERHILL, New Haven, Conn.	
V. C. VAUGHAN, Ann Arbor, Mich.	
ALFRED J. WAKEMAN, New Haven, Conn.	

VOLUME XLI
BALTIMORE
1920

COPYRIGHT 1920
BY
THE JOURNAL OF BIOLOGICAL CHEMISTRY

PUBLISHED BY THE ROCKEFELLER INSTITUTE FOR MEDICAL RESEARCH FOR THE
JOURNAL OF BIOLOGICAL CHEMISTRY, INC.

WAVERLY PRESS
THE WILLIAMS & WILKINS COMPANY
BALTIMORE, U. S. A.

CONTENTS OF VOLUME XLI.

No. 1, January, 1920.

LEVENE, P. A. Crystalline uridinphosphoric acid.....	1
JAMIESON, GEORGE S. The determination of saccharin in urine.....	3
HARVEY, R. B. A thermoregulator with the characteristics of the Beckmann thermometer. Plate 1.....	9
BUNKER, JOHN W. M. The determination of hydrogen ion concentration.....	11
KREMERS, R. E., and HALL, J. A. On the identification of citric acid in the tomato.....	15
LEVENE, P. A. The structure of yeast nucleic acid. V. Ammonia hydrolysis.....	19
ZOLLER, HARPER F. Quantitative estimation of indole in biological media.....	25
ZOLLER, HARPER F. Influence of hydrogen ion concentration upon the volatility of indole from aqueous solution.....	37
OLMSTED, W. H. Availability of carbohydrate in certain vegetables..	45
TATUM, ARTHUR L. Alkaline reserve capacity of whole blood and carbohydrate mobilization as affected by hemorrhage.....	59
WELKER, WILLIAM H., and WILLIAMSON, CHARLES SPENCER. Hemoglobin. I. Optical constants.....	75
STEENBOCK, H., and BOUTWELL, P. W. Fat-soluble vitamine. III. The comparative nutritive value of white and yellow maizes. Plate 2.....	81
SHERMAN, H. C. Protein requirement of maintenance in man and the nutritive efficiency of bread protein.....	97
ALBRECHT, P. G. Effect of iodides on the autolysis of liver tissue... 111	111
MYERS, ROLLIN G. I. A chemical study of the blood of several invertebrate animals.....	119
MYERS, ROLLIN G. II. A chemical study of whale blood.....	137

No. 2, February, 1920.

INGVALDSEN, T., and BAUMAN, L. Note on the preparation of <i>p</i> -dimethylaminobenzaldehyde.....	145
INGVALDSEN, T., and BAUMAN, L. Note on the oxidation of sugars by mercuric acetate in the presence of ammonia.....	147
STEENBOCK, H., and GROSS, E. G. Fat-soluble vitamine. IV. The fat-soluble vitamine content of green plant tissues together with some observations on their water-soluble vitamine content... 149	149
STEENBOCK, H., and BOUTWELL, P. W. Fat-soluble vitamine. V. Thermostability of the fat-soluble vitamine in plant materials. 163	163
SHERMAN, H. C. Phosphorus requirement of maintenance in man... 173	173

PETERSON, W. H., and FRED, E. B. The rôle of pentose-fermenting bacteria in the production of corn silage.....	181
MYERS, F. J., and McCLENDON, J. F. Note on the hydrogen ion concentration of the human duodenum.....	187
STADIE, WILLIAM C., and VAN SLYKE, DONALD D. Studies of acidosis. XV. Carbon dioxide content and capacity in arterial and venous blood plasma.....	191
BUCKNER, G. DAVIS, and MARTIN, J. H. Effect of calcium on the composition of the eggs and carcass of laying hens.....	195
HALVERSON, J. O., and WELLS, E. B. Note on a short modification of the official chlorine method for feeds, feces, and urine.....	205
ROBSCHT, FRIEDA S. A comparative study of hemoglobin determination by various methods.....	209
HOLMES, ARTHUR D., and DEUEL, HARRY J., JR. Digestibility of certain miscellaneous vegetable fats.....	227
STADIE, WILLIAM C. A method for the determination of methemoglobin in blood.....	237
CSONKA, F. A. A study of the nephelometric values of cholesterol and the higher fatty acids. II.....	243
LA FORGE, F. B. The heptoses from gulose and some of their derivatives.....	251
COHEN, SEYMOUR J. Studies on the secretion of gastric juice.....	257
KRAMER, B. Direct quantitative determination of potassium and sodium in small quantities of blood.....	263

No. 3, March, 1920.

OSBORNE, THOMAS B., and MENDEL, LAFAYETTE B. Nutritive value of the proteins of the barley, oat, rye, and wheat kernels.....	275
BURGE, W. E., and BURGE, E. L. Effect of the chlorine substitution products of methane, acetaldehyde, and of sodium acetate on catalase production.....	307
WOODYATT, R. T. An improved volumetric pump for continuous intravenous injections. Plate 3.....	315
SPEAKMAN, HORACE B. Biochemistry of the acetone and butyl alcohol fermentation of starch by <i>Bacillus granulobacter pectinovorum</i>	319
AUSTIN, J. HAROLD, and VAN SLYKE, DONALD D. Determination of chlorides in whole blood.....	345
ROSE, MARY SWARTZ. Experiments on the utilization of the calcium of carrots by man.....	349
DENIS, W., and MINOT, A. S. Effects of feeding with calcium salts on the calcium content of the blood.....	357
DENIS, W. Determination of magnesium in blood.....	363
FOLIN, OTTO, and WU, HSIEN. A system of blood analysis. Supplement I. A simplified and improved method for determination of sugar.....	367

FINKS, A. J., and JOHNS, CARL O. Distribution of the basic nitrogen in phaseolin.....	375
JOHNS, CARL O., and FINKS, A. J. Studies in nutrition. II. The rôle of cystine in nutrition as exemplified by nutrition experiments with the proteins of the navy bean, <i>Phaseolus vulgaris</i> ...	379
JOHNS, CARL O., FINKS, A. J., and PAUL, MABEL S. Studies in nutrition. III. The nutritive value of commercial corn gluten meal.....	391
HENDERSON, LAWRENCE J. The equilibrium between oxygen and carbonic acid in blood.....	401
PETERSON, W. H., and FRED, E. B. The fermentation of fructose by <i>Lactobacillus pentoaceticus</i> , n. sp.....	431
OSBORNE, THOMAS B., and MENDEL, LAFAYETTE B. Nutritive factors in plant tissues. III. Further observation on the distribution of water-soluble vitamine.....	451
Proceedings of the American Society of Biological Chemists, XIII...	i
Proceedings of the American Society of Biological Chemists, Inc., XIV.	xxix

No. 4, April, 1920.

KOHMAN, EDWARD F., and SHONLE, H. A. The digestibility of chicken skin.....	469
COLLIP, J. B. Effect of sleep upon the alkali reserve of the plasma...	473
DOX, ARTHUR W., and ROARK, G. W., JR. The utilization of α -methylglucoside by <i>Aspergillus niger</i>	475
LEVENE, P. A. Properties of the nucleotides obtained from yeast nucleic acid. Plates 4 and 5.....	483
SANDO, CHARLES E., and BARTLETT, H. H. Rutin, the flavone pigment of <i>Escholtzia californica</i> Cham. Plates 6 and 7.....	495
SHORT, JAMES J. The formation of acetone bodies following ether anesthesia and their relation to the plasma bicarbonate.....	503
OSBORNE, THOMAS B., and MENDEL, LAFAYETTE B. Milk as a source of water-soluble vitamine. II.....	515
THEIS, RUTH C., and BAGG, HALSEY J. The effect of intravenous injections of active deposit of radium on metabolism in the dog.	525
HOWARD, FREDERICK H. The determination of the refractivity of hemoglobin in solution.....	537
OSBORNE, THOMAS B., and MENDEL, LAFAYETTE B. Nutritive factors in plant tissues. IV. Fat-soluble vitamine.....	549
VAN SLYKE, DONALD D., and PALMER, W. W. Studies of acidosis. XVI. The titration of organic acids in the urine.....	567
CULLEN, GLENN E., and VAN SLYKE, DONALD D. Determination of the fibrin, globulin, and albumin nitrogen of blood plasma.....	587
HAMMETT, FREDERICK S. Studies of variations in the chemical composition of human blood.....	599
SOMMER, H. H., and HART, E. B. The heat coagulation of milk.....	617
KOEHLER, A. E. A new 0.1 N calomel electrode design.....	619
Index to Volume XLI.....	621

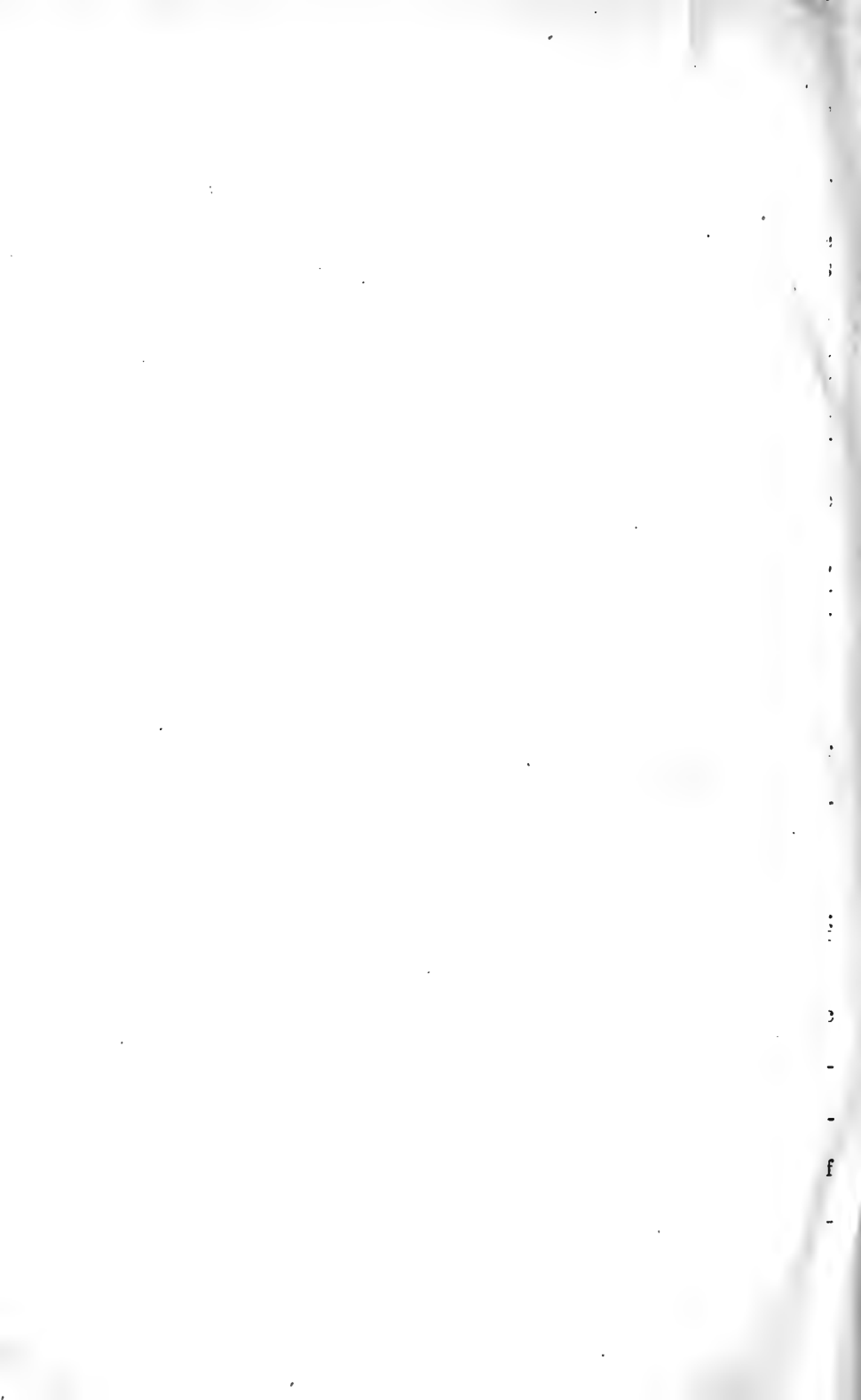

CRYSTALLINE URIDINPHOSPHORIC ACID.

By P. A. LEVENE.

(From the Laboratories of The Rockefeller Institute for Medical Research.)

(Received for publication, November 28, 1919.)

In previous communications¹ crystalline salts of uridinphosphoric acid were described. They were the brucine salt, two ammonium salts, the lead, and the barium salt. Nearly every one has its value in the process of preparation of the free uridinphosphoric acid. The insolubility of the brucine salt is the property on which is based the separation of this from a mixture containing other nucleotides. The ammonium salt is the transition step from the brucine salt to every other salt; the lead salt serves for separation of the nucleotide in its pure state, and hence for its identification when the nucleotide is available in only small quantities. For final identification the crystalline nucleotide offers the most satisfactory material. It was prepared in the following manner.

The diammonium salt described in the previous communication was converted into the lead salt. This was suspended in water, and through the suspension a stream of hydrogen sulfide gas was passed. The filtrate from lead sulfide was freed from hydrogen sulfide by distillation under diminished pressure at room temperature. To the clear solution of the nucleotide a solution of neutral lead acetate was added to form again the lead salt. The lead salt was again treated with hydrogen sulfide as before, the resulting clear solution was concentrated under diminished pressure to a small volume, and then placed in a vacuum desiccator, where it was allowed to concentrate slowly under diminished pressure. When the solution attained the thickness of glycerol it was dissolved in hot 99.5 per cent alcohol and again placed in a vacuum desiccator and allowed to concentrate under diminished

¹ Levene, P. A., *Proc. Soc. Exp. Biol. and Med.*, 1917, xv, 21; *J. Biol. Chem.*, 1918, xxxiii, 229; 1919, xl, 395.

pressure over sulfuric acid. This operation was repeated many times and finally the thick syrup crystallized into a nearly solid, sticky mass. In order to separate the crystals from the viscous mother liquor the material was triturated with a very small quantity of hot anhydrous methyl alcohol. The crystalline material was then washed with cold methyl alcohol, and finally the substance was suspended in dry methyl alcohol. The mixture was brought to a boil and then the crystals were filtered off. The mother liquors and the wash alcohol on standing under diminished pressure over sulfuric acid gave a second crop of crystals. The substance had the melting point M. P. = 202° (corrected) with decomposition and the following composition.

0.1000 gm. of the substance gave 0.1231 gm. of CO₂ and 0.0376 gm. of H₂O.

0.2000 " " " " employed for Kjeldahl nitrogen estimation required 12.36 cc. of 0.1 N acid for neutralization.

0.3000 gm. of the substance gave 0.1020 gm. of Mg₂P₂O₇.

	Calculated for C ₉ H ₁₃ N ₂ PO ₉ <i>per cent</i>	Found. <i>per cent</i>
C	33.32	33.40
H	4.05	4.18
N	8.64	8.65
P	9.58	9.48

The optical rotation of the substance was

$$[\alpha]_D^{20} = \frac{+ 0.21 \times 100}{1 \times 2} = + 10.5$$

Thus every one of the four nucleotides composing the molecule of yeast nucleic acid has now been prepared in crystalline form.

THE DETERMINATION OF SACCHARIN IN URINE.

BY GEORGE S. JAMIESON.

(From the Bureau of Chemistry, U. S. Department of Agriculture.)

(Received for publication, November 25, 1919.)

The method to be described is based upon the quantitative extraction of the saccharin with ether from the acidified urine which had been previously treated with normal lead acetate and filtered. The sulfur of the extracted saccharin was determined as barium sulfate, after the fusion of the residue from the ether with sodium carbonate. The amount of saccharin present was found by multiplying the weight of the barium sulfate by 0.7844. Ether was chosen as the most suitable solvent because it had been shown by Marden¹ that saccharin could be readily extracted in a quantitative manner with ether from aqueous solutions which had been acidified with hydrochloric acid. For references upon the determination of saccharin the reader may consult the researches described by Gnadinger,² and Seeker and Wolf.³

It has been found by employing the modification of the sulfur method used for the determination of saccharin in food substances, described below, that satisfactory results can be obtained for amounts of saccharin varying from 1 mg. upwards per 100 cc. of urine. Smaller amounts of saccharin could probably be estimated with some accuracy by using larger quantities of urine for the analysis. A detailed description of the procedure will be given so that other analysts may obtain accurate results with this method.

In order to test the method, a standard solution was prepared which contained 1 mg. of saccharin per cc. The saccharin used was a high grade commercial product which had been previously analyzed in order to determine its purity. It melted at about

¹ Marden, J. W., *J. Ind. and Eng. Chem.*, 1914, vi, 315.

² Gnadinger, C. B., *J. Assn. Off. Agric. Chem.*, 1917, iii, 23-33.

³ Seeker, A. F., and Wolf, M. G., *J. Assn. Off. Agric. Chem.*, 1917, iii, 38-43.

220°C. The ignition of about 0.2 gm. on a platinum foil left no perceptible residue. The amount of actual saccharin present in the sample was determined by the well known Reid method⁴ and it was found to contain 98.79 per cent (average of two closely agreeing analyses). On the basis of the analyses, 2 liters of solution were prepared so that 1 cc. should contain 1 mg. of saccharin. This solution was standardized by determining the amount of saccharin present in measured volumes by the sulfur method described below. The average of two closely agreeing analyses gave the value 1 cc. = 0.00100 gm. of saccharin, which is in agreement with the results previously obtained by the Reid method. Measured quantities of the standard saccharin solution were added to 100 cc. portions of urine which was sometimes fresh and at other times 1 or 2 days old. To each solution, 10 cc. of a 20 per cent normal lead acetate solution were added and after thorough stirring the solution was allowed to stand for an hour before filtration. It was found essential to heat urine which contained albumin almost to boiling for a few minutes, and then add the lead acetate solution, otherwise unbreakable emulsions were formed when the aqueous solution was agitated with ether to extract the saccharin. After heating, the solutions were allowed to stand for 1 hour before filtration as previously described.

Since it is important to add a slight but distinct excess of lead acetate over that required for the precipitation of the compounds which if left in the solution would interfere with the extraction of the saccharin by ether, by causing the formation of emulsions, it is necessary to make some preliminary experiments to determine the proper volume of lead acetate required for each urine. It has been observed that a weak urine requires somewhat less lead acetate than a strong, highly colored urine. However, after a little experience, one can closely estimate the proper amount of lead acetate required, in the majority of cases, from the color of the urine to be examined. On the other hand, if more than a slight excess of lead acetate over the required amount was present, the precipitated lead chloride formed when the solution was strongly acidified with hydrochloric acid previous to the ether extractions was found to interfere with the complete recovery of

⁴ Reid, E. E. *Am. Chem. J.*, 1899, xxi, 461.

the saccharin present. The solution was filtered by suction through a mat of paper pulp about 0.5 cm. thick. The paper pulp was prepared by stirring filter clippings with enough concentrated hydrochloric acid to moisten it until it was thoroughly disintegrated. Then about 15 volumes of water were added and, after shaking, the mixture was ready for use. When the proper thickness of mat had been obtained in a 6 cm. funnel, it was washed three times with about 50 cc. of water each time to remove the acid. When the lead precipitate was in the funnel and most of the solution had filtered through, it was washed four times, using about 10 cc. of water each time. During the first part of the filtration, a gentle suction was used, but when the precipitate was ready for washing, the full suction was used. The suction was continued until no more filtrate was obtained even after the precipitate had been firmly pressed to a hard mass with a spatula. It should be added that the funnel and precipitate were washed again with a small quantity of water after the precipitate had cracked just before pressing it down with the spatula. It was found that the filtration, including the washing and pressing of the precipitate, usually required about 1 hour. It is most important that every piece of apparatus used in the analysis be rinsed absolutely free from sulfates and furthermore the analysis must be made in a room where sulfuric acid is not volatilized. The filtrate was transferred to a suitably sized separatory funnel and the filtering flask was rinsed twice with about 5 cc. of water. Then 15 cc. of concentrated hydrochloric acid were added and, after mixing, 55 cc. of ether were added. The contents of the funnel were shaken for 2 minutes. After the layers had separated for about 10 minutes, the aqueous solution was drawn into a clean beaker. The ether was rotated in order to wash the sides of the funnel as free as possible from water. When the water had settled to the bottom of the funnel, it was tapped off. The ether was poured into a 600 cc. beaker and evaporated by directing a gentle current of air on the surface. The aqueous solution was returned to the funnel and extracted again with 50 cc. of ether in precisely the same manner as before. The second ether extract was added to the beaker containing the first extract and a third extraction using the same volume of ether was made. When the combined ether extracts had been evaporated as completely as

possible with the air current, the remaining moisture was removed by heating the beaker on a steam bath. Care was taken not to heat so strongly as to cause the solution to boil. It is very important not to allow a single drop of aqueous solution to be carried along when transferring the ether to the beaker from the separatory funnel. The residue from the ether was allowed to cool to room temperature and treated with about 12 cc. of absolute ether by pouring it around the upper edge of the beaker so as to wash down the saccharin adhering to the sides. The ether was allowed to remain on the residue for 5 minutes; then it was transferred to a 30 cc. nickel crucible. While the ether was being evaporated by a gentle current of air directed on the surface of the liquid, the residue was extracted again with 12 cc. of absolute ether. This ether extract was added to the crucible. A third portion of about 15 cc. of absolute ether was added to the residue which was detached from the sides and bottom of the beaker by rubbing with a stout glass rod. A rubber-tipped rod must not be employed. This extract was filtered to remove the suspended sediment through a 5 cm. filter into the crucible. The beaker was rinsed and the residue was stirred with another 15 cc. portion of ether which was filtered and added to the crucible. Then the filter was washed by adding about 5 cc. more of ether around the upper edge. When the ether had evaporated, about 2 gm. of anhydrous sodium carbonate were added. The sodium carbonate was spread, by means of a small spatula, up the sides of the crucible as far as the residue extended. The nickel crucible was placed in a porcelain crucible and heated for 10 minutes with a low flame. Then the flame was gradually increased to its full capacity. At this point, the porcelain crucible was removed and the nickel crucible was heated directly for 5 minutes at the highest temperature of the burner. When the crucible was cold, 20 cc. of water were added and, after standing for about 10 minutes, the contents of the crucible were heated almost to boiling. The solution was filtered through a 9 cm. washed filter and the crucible was rinsed several times with warm water. After washing the filter four times with water, the beaker containing the filtrate was covered and the solution was acidified with 5 cc. of hydrochloric acid. The solution was heated for 5 minutes on the steam bath before adding 10 cc. of a 10 per cent solution of barium chloride to

precipitate the sulfate. When the solution had been heated for about 3 hours, it was allowed to cool to about 50°C. It was filtered on a carefully prepared Gooch crucible and washed with 60 to 75 cc. of water. In filtering small amounts of barium sulfate, it was found best to use a very gentle suction until after the final washing had ceased running through. At this point the suction was increased very gradually until the maximum was reached. The crucible containing the precipitate was placed in a porcelain crucible and heated for a short time with a small flame. Then it was heated with the full flame for 5 minutes. When the crucible

TABLE I.

No.	Saccharin taken with 100 cc. urine.	Barium sulfate found.	Saccharin cal- culated.	Error.
	<i>gm.</i>	<i>gm.</i>	<i>gm.</i>	<i>gm.</i>
1	0.0120	0.0149	0.0117	-0.0003
2	0.0120	0.0153	0.0120	0.0000
3	0.0080	0.0099	0.0078	-0.0002
4	0.0080	0.0102	0.0080	0.0000
5	0.0005	0.0007	0.0005	0.0000
6	0.0051	0.0064	0.0052	+0.0001
7	0.0040	0.0050	0.0039	-0.0001
8	0.0030	0.0040	0.0031	+0.0001
9	0.0010	0.0015	0.0012	+0.0002
10	0.0020	0.0027	0.0021	+0.0001
11	0.0020	0.0032	0.0024	+0.0004
12	0.0030	0.0040	0.0031	+0.0001
13	0.0050	0.0060	0.0047	-0.0003
14	0.0050	0.0062	0.0050	0.0000
15	0.0100	0.0126	0.0099	-0.0001

had cooled for 20 minutes it was weighed. The weight of barium sulfate obtained after deducting the blank correction described below was multiplied by 0.7844 to obtain the weight of saccharin which it represented. A blank analysis for sulfate was made using all the reagents in the same amounts as in the actual experiments and less than 0.1 mg. of barium sulfate was obtained. Several blank analyses were made at various times carrying out the entire process with 100 cc. portions of urine as described above. The average of the blank analyses amounted to 0.7 mg. of barium sulfate which has been deducted from the weights of barium sulfate given in Table I.

From the table of analyses it will be observed that very satisfactory results were obtained. In order to obtain good results, it is most essential that the directions given above should be executed with the greatest care possible. Furthermore, before attempting to apply this method a sufficient number of blank analyses should be made, if possible, upon urine of the subject to be experimented upon, so that the proper correction can be applied in connection with the determination of saccharin.

SUMMARY.

Urine is treated with a solution of lead acetate and filtered. After acidifying with hydrochloric acid, the saccharin is extracted by ether, the ether removed by evaporation, and the saccharin extracted from the residue with ether. The ether is removed and the resulting residue is fused with sodium carbonate and the sulfur determined as barium sulfate. The amount of saccharin is calculated from the sulfur found after making a correction for the blank. The experimental results obtained by the analysis of urines, to which known amounts of saccharin had been added, show that the method is capable of giving satisfactory results providing that the directions are followed exactly as described in every detail.

A THERMOREGULATOR WITH THE CHARACTERISTICS OF THE BECKMANN THERMOMETER.

BY R. B. HARVEY.

*(From the Bureau of Plant Industry, United States Department of
Agriculture, Washington.)*

PLATE I.

(Received for publication, November 17, 1919.)

In working at low temperatures in a constant temperature chamber it was found desirable to reduce the heat capacity of the thermoregulator as much as possible in order to give quick response to small changes in temperature of the air. It was found advantageous also to have the thermoregulator show the same lag effects as the standard measuring instrument, the Beckmann thermometer.

The instrument here shown (Plate 1) can be set easily at any temperature desired between -20 and $+250^{\circ}\text{C}$. Approximate settings can be made by warming or cooling the mercury bulb until the upper level of the column reaches the desired point on the setting scale. For making more accurate settings a slight blow will separate a series of small globules of mercury from either portion after the mercury is divided approximately by means of the scale. As many of these droplets as are desired can be added to the contents of the bulb by turning the instrument upside down. The capillary is sufficiently large to allow the mercury in the bulb to flow through it easily when the column is broken by a slight blow with a pencil. The instrument is thus more easily set than the ordinary Beckmann thermometer.

The lower platinum contact should be made in an enlargement of the capillary to prevent sticking of the mercury at that point. The upper contact is placed at the end of the capillary so that small temperature changes will make or break the circuit. The mercury column is of sufficient diameter to carry the current required to operate a 150 ohm relay using 2 or 4 volts. The heating circuit should be broken by a relay.

When run on test in the air bath with a standard Beckmann thermometer the air temperature was regulated within $\pm 0.004^{\circ}\text{C}$. when stirred vigorously. The accuracy of regulation of the air temperature varies greatly with the heat capacity of the source of heat and the rate of stirring.



(Harvey: Thermoregulator.)



THE DETERMINATION OF HYDROGEN ION CONCENTRATION.

By JOHN W. M. BUNKER.

(From the Department of Bacteriology, Digestive Ferments Company, Detroit.)

(Received for publication, November 12, 1919.)

The reasons for the measurement of reaction of culture media and biologic fluids in terms of pH are well covered by numerous publications upon the subject. The art of making the determination is still susceptible of great variations in method. Certain principles concerning the technique of electrolytic determinations are important. The electrode itself should be as simple in construction as possible, in order that it may be easily cleaned and easily replaced. The measurement of small quantities of test liquid should be possible. Easy attainment of equilibrium in the solution should be expected. Those parts of the apparatus which come in contact with test liquids should be easily subjected to sterilization.

An electrode and vessel are here described which fulfil some of these requirements. In its design, ideas have been borrowed freely from published work and through personal observations. It is a modification of the bubbling electrode, used in a closed vessel.

The tube used to conduct the hydrogen gas to the platinum wire of the hydrogen electrode is the essential part of this apparatus. It is indicated by E in Fig. 1. This is a piece of glass tubing of $\frac{5}{16}$ inch internal bore with a side arm of small diameter joined to it at approximately 1 inch from the top. The $\frac{5}{16}$ inch tubing is about 5 inches long over all. In its preparation it is sealed at the bottom and then heated on one lower "corner," and a bubble at this point is blown and later broken with a file. The edges of the lip which remain are fire-polished, and then the end of the tube is heated and the round hole thus obtained is contracted to an approximately oval shape.

The hydrogen electrode itself, B, is made from a piece of $\frac{1}{8}$ inch tubing with a short piece of platinum wire sealed in at the bottom, projecting outside about $\frac{1}{8}$ inch, and inside far enough to make contact with mercury C, with which the lower part of this tube is filled. A small rubber stopper A is fitted tightly around this tube at about 1 inch from the top. The entire electrode is about 6 inches long. In assembling the apparatus, the electrode tube B

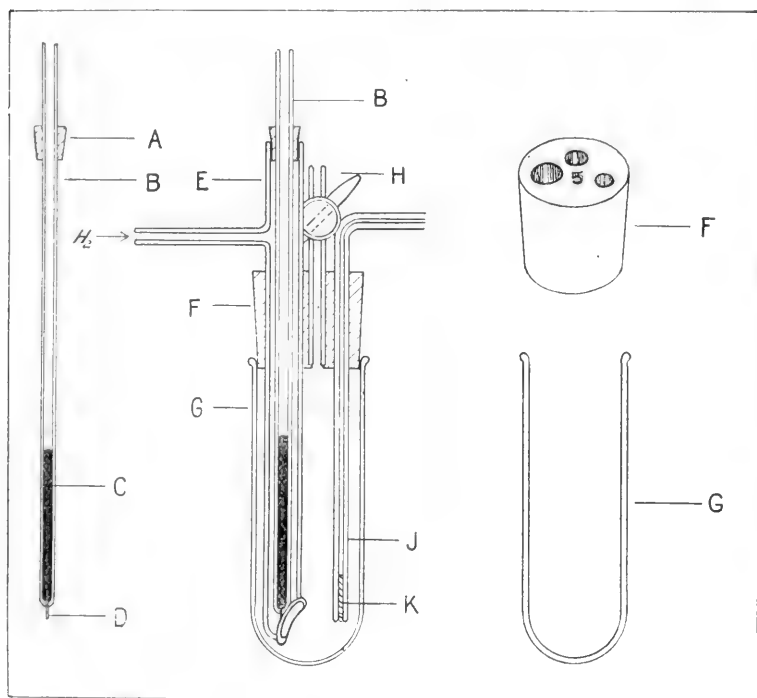

FIG. 1. Diagram of hydrogen electrode.

with its stopper A is inserted in tube E and pushed down tightly, and so adjusted that the platinum wire D is opposite the orifice in the lower end of the tube E. The exact point of this must be determined by trial, as must the size and shape of the orifice. When the assembled electrode is dipped in a liquid, and gas is bubbled through it in the direction indicated, there should form a large bubble at the base of the tube E which is held together

by the walls of the tube until it has travelled far enough for the level of the liquid within the tube to have reached a point below the platinum wire, thus exposing the wire to hydrogen gas. The bubble is pushed out of the tube and, as it leaves, the liquid rushes in behind it up into the tube, and should again bathe the platinum needle in liquid. This gives the effect of the rocking electrode of Clark,¹ in which the platinum electrode itself is bathed alternately in liquid and in gas. If the orifice is too wide, the bubble will be pushed out before it has travelled far enough to clear the platinum needle, and in that case the tube E must be dried, reheated in the flame, and the opening constricted.

The electrode vessel G which we call a pH tube, is an ordinary test-tube of 1 inch internal diameter, and approximately 3 inches in length. The exact dimensions are not important. We have a supply of these tubes on hand, carefully washed and dried properly, and stored away ready for determinations. When a series of determinations of pH is to be made, the proper number of tubes is selected, each is given its proper liquid, and is set up in a rack ready to use. One by one each may then be pushed up under the hydrogen electrode against the rubber stopper F and, as soon as the determination is read, slipped out to make way for the next.

The rubber stopper F is a No. 5 stopper with three holes made by cork borers to receive tightly the tube E and the outlet tube H with its stop-cock, and to receive not so tightly, the potassium chloride arm J, which is made of small capillary tubing. The rubber stopper is slipped up over the hydrogen electrode tube E and fastened to it with cement or shellac. The outlet tube H which carries a stop-cock is inserted into the rubber stopper, and also cemented in place. The stopper remains on the tube E at all times. The capillary tube J plugged at the end with a bit of cotton wicking K makes the connection between the saturated potassium chloride of the calomel half-cell and the test liquid. The tube J slips up and down in the stopper and should fit as tightly as possible, still allowing the necessary motion. The apparatus is assembled as in Fig. 1. Hydrogen gas is bubbled through the inlet tube for approximately 30 seconds at a rapid

¹Clark, W. M., *J. Biol. Chem.*, 1915, xxiii, 475.

rate, with the outlet tube H open and the potassium chloride arm J lifted out of the test liquid. Then the stream of hydrogen is slowed down to such a rate that the bubble travels in the lower end of the tube E once every 2 seconds. This is maintained for about 1 minute. The relation of the parts, the volume of liquid, and the size of the bubble of hydrogen liberated are such that adequate stirring of the test liquid is obtained by the bubbling, and it is not necessary to shake or rock the apparatus. At the end of the bubbling the hydrogen is shut off, by an external stop-cock, just after a bubble of gas has been liberated from the tube E and the liquid has assumed a level in the tube above the platinum needle D. The stop-cock in the outlet tube is immediately closed, thus insuring an atmosphere of hydrogen gas over the test liquid in a closed vessel. The potassium chloride arm J is then lowered so that contact is made, and reading is taken by whatever electro-metric apparatus is available.

If it is desirable to avoid all chance of contact-potential error, the wicking K in the potassium chloride arm J may be dispensed with, and, after the arm J is lowered to the bottom of the pH tube E, potassium chloride may be run in under the test solution in order to make a wide zone of contact between the potassium chloride and the test solution, the arm J, of course, being lowered to make contact with the volume of potassium chloride in the bottom of the tube G, and the stop-cock outside of the apparatus closed to prevent further inflow of potassium chloride. There will always be enough potassium chloride between the stop-cock and its jacket to transmit the necessary E. M. F. In the writer's opinion the error is less and the convenience greater if the wicking is retained in the potassium chloride arm, and the outside stop-cock is left open in order to insure plenty of electrolyte along the whole course which the current must travel.

The apparatus is designed to meet the requirements of quick, accurate determinations in large numbers, and has been in use satisfactorily for a long period of time. A number of electrode parts B may be made from the same piece of platinum wire and, when treated in the same way as to blacking, may be substituted in the apparatus when necessary without loss of accuracy. All electrodes must of course be tested as to blacking against a standard acetate or other known buffer solution.

ON THE IDENTIFICATION OF CITRIC ACID IN THE TOMATO.

BY R. E. KREMERS AND J. A. HALL.

(From the Phytochemical Laboratory of Edward Kremers, University of Wisconsin, Madison.)

(Received for publication, November 11, 1919.)

In spite of the large amount of work which has been done on the chemistry of the tomato, Hansen,¹ working in this laboratory a few years ago, was the first to isolate citric acid in crystal form from the juice of the tomato and to make an elementary analysis of his material. With more material available, it was desired to repeat Hansen's experiments. The recent work of Reid² and his colaborers suggested the application of derivatives of citric acid to its identification.

Citric Acid Triphenacyl Ester.—In order to familiarize ourselves with the procedure, the reaction was applied to U. S. P. sodium citrate. Instead of using the phenacyl bromide in slight excess, as Reid suggests, our experience seems to indicate that a slight excess of sodium citrate is preferable. The record of a typical experiment is as follows: 3.263 gm. of sodium citrate were dissolved in 27.5 cc. of water and 5.4114 gm. of phenacyl bromide and 55 cc. of 95 per cent alcohol were added. Alcohol has the property of precipitating an aqueous solution of Na citrate. On continued refluxing with frequent agitation the aqueous layer gradually disappears. The attainment of homogeneity is a good indication that the reaction is nearly complete. Refluxing on a boiling water bath was continued for 4 hours. The reaction mixture was poured into a crystallizing dish, set upon the water bath after the

¹ Unpublished results.

² Reid, E. E., *J. Am. Chem. Soc.*, 1917, xxxix, 124. Lyman, J. A., and Reid, E. E., *J. Am. Chem. Soc.*, 1917, xxxix, 701. Lyons, E., and Reid, E. E., *J. Am. Chem. Soc.*, 1917, xxxix, 1727. Rather, J. B., and Reid, E. E., *J. Am. Chem. Soc.*, 1919, xli, 75.

flame had been extinguished, and allowed to stand. If in a day or two the precipitate has not crystallized, it is redissolved in hot 95 per cent alcohol, from which it is usually obtained crystalline. Melting point 105° . Reid found 104° .

Unfortunately Reid gives no analytical data for his compounds. The following results were obtained with our material.

Combustion.—(No. 1.) 0.2159 gm. of ester gave 0.0975 gm. of H_2O and 0.5243 gm. of CO_2 .

(No. 2.) 0.2452 gm. of ester gave 0.1133 gm. of H_2O and 0.5907 gm. of CO_2 .

	Carbon. <i>per cent</i>	Hydrogen. <i>per cent</i>	Oxygen. <i>per cent</i>
No. 1.....	66.23	5.00	28.77
" 2.....	65.70	5.14	29.16
Theoretical.....	65.93	4.76	29.31

Saponification.—A quantitative saponification was undertaken several times; each time the results were too high for a tri-ester and no definite end-point could be located. Even cold $N/2$ NaOH gave too high results. According to Beilstein, phenacyl alcohol is readily decomposed even by dilute alkali.

Although Reid had obtained practically negative results in his attempts to prepare mono-*p*-nitrobenzyl esters of di-basic acids, it seemed worth while to try at least a few orienting experiments along the same line before proceeding with the acids from the tomato. Accordingly di- and monosodium citrate were prepared according to the directions of Heldt.³

The phenacyl esters were prepared in the same manner as the tri-ester; *i.e.*, the Na salt was slightly in excess of the theoretical quantity. The esters were crystallized as before.

	Di-ester. $^{\circ}C.$	Mono-ester. $^{\circ}C.$
M. P. of ester.....	104-105	104.5
M. P. mixed with tri-ester.....	105	104.5

Therefore the triphenacyl ester separates in each case. Perhaps the simplest explanation, in the absence of more experimental data, is that Heldt's mono- and disodium citrates are not truly named, but are merely mixtures of trisodium citrate and citric

³ Heldt, W., *Ann. Chem.*, 1843, xlvii, 157.

acid having the analytical composition indicated by their names. The method of preparation and the fact that Heldt prepared no corresponding salts by double decomposition with other metals rather support this supposition.

Application to the Tomato.

Material.—The material was obtained by saturating strained tomato pulp⁴ with calcium hydroxide; the Ca citrate is thereupon precipitated by boiling. That the material thus prepared is not nearly pure Ca citrate is shown by the analysis for Ca.

Found 15.6 per cent. Ca citrate requires 24.1 per cent.

The impure Ca salt did not yield crystals when brought into reaction with phenacyl bromide. Its purification was undertaken as follows after various trials:

The impure Ca salt was converted into the Na salt by boiling with Na_2CO_3 . Ca citrate was reprecipitated by adding NH_4Cl and CaCl_2 in excess to the solution of the Na salt, boiling and filtering while hot. The Ca salt dissolves in 50 per cent acetic acid on continuous stirring, from which solution the Pb salt is precipitated by basic Pb acetate. The Pb salt was decomposed by H_2S , the citric acid solution filtered from the Pb sulfide, concentrated *in vacuo*, and crystallized in a vacuum desiccator. The triphenacyl ester was then prepared as follows:

0.7382 gm. of citric acid dissolved in 9 cc. of water was neutralized with 0.5389 gm. of Na_2CO_3 . 1.61 gm. of phenacyl bromide dissolved in 18 cc. of alcohol were added and the mixture was refluxed for 3 hours. The reaction mixture was crystallized; yield 0.52 gm., melting point $104\text{--}105^\circ$. Mixed with ester from U. S. P. sodium citrate, melting point was $104\text{--}105^\circ$.

Therefore the presence of citric acid in the tomato juice has been shown by means of its triphenacyl ester.

⁴ For the material at our disposal we are much indebted to the Tomato Products Company of Paoli, Ind.



THE STRUCTURE OF YEAST NUCLEIC ACID.

V. AMMONIA HYDROLYSIS.

By P. A. LEVENE.

(From the Laboratories of The Rockefeller Institute for Medical Research.)

(Received for publication, December 1, 1919.)

In the preceding publication of this series¹ the statement was made that on mild hydrolysis with 5 per cent ammonia at a temperature of 100°C. yeast nucleic acid is broken up into four mononucleotides. The publication contained a report of the isolation of only three of these. At the time when that publication went to press, the fourth nucleotide had been isolated in the form of the brucine salt. However, we have learned that for the identification of a nucleotide one cannot depend on the analysis of only the brucine salt, when this salt is obtained from a mixture of brucine salts of several nucleotides.

The present publication contains a report on the isolation of the fourth nucleotide, the crystalline cytidinphosphoric acid. It also presents an example showing that not only the brucine salts, but also the free nucleotides are capable of forming mixed crystals, which may furnish analytical data very nearly approaching those required by polynucleotides. A crystalline substance was isolated, which, on the basis of its elementary analysis, could easily have been taken for an adenosin-uridin dinucleotide. On recrystallization from dilute alcohol, the substance was fractionated into cytidinphosphoric and adenosinphosphoric acids. Thus it is evident that the danger of error is extremely great if one assumes the existence of di- or trinucleotides on the basis of the results of elementary analysis.

EXPERIMENTAL.

The material for the present work was the brucine salts of the adenine fraction. It was stated in the preceding communication that these brucine salts were recrystallized nine times out of

¹ Levene, P. A., *J. Biol. Chem.*, 1919, xl, 415.

35 per cent alcohol. The final product consisted of the brucine salt of uridinphosphoric in a practically pure state. This was demonstrated by the fact that, when the brucine salt was converted into the ammonium salt, this without further purification was in a crystalline state and had an elementary composition required by the theory of that salt.

The first three mother liquors combined and concentrated yielded a brucine salt containing 10 per cent nitrogen, which served for the isolation of adenosinphosphoric acid described in the preceding publication.

The mother liquors from the fourth to the ninth (inclusive) recrystallizations served as starting material for the isolation of cytidinphosphoric acid. The crude brucine salts obtained on concentration of the mother liquors were first fractionated by means of methyl alcohol. For this purpose the brucine salts were suspended in methyl alcohol, boiled for 15 minutes on boiling water bath, and filtered while hot. There were obtained an insoluble part A and the mother liquor, which on cooling deposited a sediment B; the mother liquor from B on concentration under diminished pressure gave a third precipitate C. The last was too small for further work. Fraction A was recrystallized three times out of 35 per cent alcohol. The brucine salt had a nitrogen content $N = 7.71$ per cent. It was converted into the ammonium salt, and this into the lead salt. The latter was suspended in water. Through the suspension hydrogen sulfide gas was passed and the filtrate from lead sulfide was concentrated to small volume under diminished pressure, finally placed in vacuum desiccator over sulfuric acid, and allowed to crystallize under diminished pressure. When the solution was concentrated to the consistency of a syrup, there began to form a crystalline deposit consisting of long needles. The mother liquor was very viscous and the crystals were freed from it by repeated washing with hot methyl alcohol. Apparently the mother liquor contained some uridinphosphoric, which is extremely soluble in water.

The crystalline substance was analyzed without recrystallization. It had a melting point M.P. = 225°C . (corrected) with decomposition. The analysis of the substance was as follows.

0.1106 gm. of the substance employed for Kjeldahl nitrogen estimation required 10.34 cc. of 0.1 N acid.

	Calculated for $C_9H_{14}N_4PO_8$ per cent	Found. per cent
N.....	13.00	13.09

The optical rotation of the substance was as follows.

$$[\alpha]_D^{20} = \frac{+1.05 \times 100}{1 \times 2} = +52.5$$

The rotation of the cytidinphosphoric acid isolated by Thannhauser was $[\alpha]_D^{20} = +23.3$, and the value calculated from the barium salt described by the writer was also $[\alpha]_D^{20} = +23$. The reason for this discrepancy will have to be established. The two latter preparations were obtained on acid hydrolysis.

Fraction B was recrystallized four times out of 35 per cent alcohol. The resulting substance was converted into the ammonium salt, which in its turn was converted into the lead salt, and this was freed from lead and thus a solution of free nucleotides was obtained. This was concentrated under diminished pressure and the solution allowed to crystallize in the open air. Crystallization began rapidly and was completed after 3 days. The crystal form differed from that of the pure nucleotides. The latter appear in form of long fine needles, while these had the appearance of heavy prisms. The substance was recrystallized once out of hot water and then had the following composition.

0.1170 gm. of the substance gave 0.1453 gm. of CO_2 and 0.0419 gm. of H_2O .

0.1930 gm. of the substance employed for Kjeldahl nitrogen estimation required 20.60 cc. of 0.1 N acid for neutralization.

0.2845 gm. of the substance gave 0.0954 gm. of $Mg_2P_2O_7$.

	Calculated for $C_{19}H_{25}N_7O_{13}P_2$ per cent	Found. per cent
C.....	34.90	33.86
H.....	3.86	4.12
N.....	15.01	14.94
P.....	9.50	9.19

The optical rotation of this substance was

$$[\alpha]_D^{20} = \frac{+0.40 \times 100}{1 \times 2} = +20.0$$

Thus the substance could easily be taken for a dinucleotide. It was separated into two fractions in the following manner: 4.8 gm. of the substance were dissolved in 150 cc. of hot water, and to this solution 300 cc. of 99.5 per cent alcohol were added gradually. On cooling a crystalline deposit began to form. After 1 hour this was removed by filtration. The yield of the air-dry material was 2.8 gm. (Fraction A). In the mother liquor on concentration under diminished pressure a deposit formed consisting of long needles (Fraction B).

Fraction A₁ analyzed as follows.

0.1006 gm. of the substance gave 0.1216 gm. of CO₂ and 0.040 gm. of H₂O.
0.2000 " " " " employed for Kjeldahl nitrogen estimation
required 18.92 cc. of 0.1 N acid.

0.2940 gm. of the substance gave 0.0982 gm. of Mg₂P₂O₇.

The optical rotation of the substance was

$$[\alpha]_D^{25} = \frac{+0.80 \times 100}{1 \times 2} = +40.0$$

Once recrystallized out of water the substance analyzed as follows.

0.0986 gm. of the substance gave 0.1206 gm. of CO₂ and 0.041 gm. of H₂O.

0.1973 gm. of the substance employed for Kjeldahl nitrogen estimation
required for neutralization 18.33 cc. of 0.1 N acid.

The optical rotation of the substance was

$$[\alpha]_D^{25} = \frac{+0.86 \times 100}{1 \times 2} = +43$$

	Calculated for C ₉ H ₁₄ N ₃ PO ₄ per cent	Sample A ₁ per cent	Found. Sample A ₂ per cent
C.....	33.42	33.57	33.35
H.....	4.37	4.44	4.64
N.....	13.00	13.51	13.01
P.....	9.61	9.30	

Fraction B₁ analyzed as follows.

0.2000 gm. of the substance employed for Kjeldahl nitrogen estimation
required for neutralization 26.24 cc. of 0.1 N acid.

	Calculated for $C_{10}H_{11}N_6PO_7$ <i>per cent</i>	Found. <i>per cent</i>
N.....	20.17	18.44

The optical rotation of the substance was

$$[\alpha]_D^{20} = \frac{-0.78 \times 100}{1 \times 2} = -39.0$$



QUANTITATIVE ESTIMATION OF INDOLE IN BIOLOGICAL MEDIA.*

BY HARPER F. ZOLLER.

(From the Research Laboratories of the Dairy Division, Bureau of Animal Industry, United States Department of Agriculture, Washington.)

(Received for publication, November 25, 1919.)

The demand for a rapid and yet delicate method for quantitatively estimating indole arose from a study of its progressive formation in certain bacterial cultures in this laboratory. It is rather remarkable that few methods have been proposed for determining this important product of the metabolism of certain microorganisms. Among those deserving attention are the suggestions of Herter and Foster (1), for the successful application of which we are indebted to Gorter and de Graff (2), and more especially to Bergeim (3); also the application of the nitroso reaction by von Moraczewskii (4) and by Nonnotte and Demanche (5). Both these methods depend upon the use of very sensitive color reactions.

The use of the color reaction of Ehrlich (*p*-dimethylamino-benzaldehyde) was considered but dismissed after a few trials for several reasons: (a) it reacts readily with phenolic compounds; (b) it is extremely slow in attaining equilibrium as regards its full deep color (6); (c) it is a difficult compound to obtain, and was expensive at the time of the investigation; and (d) the reagent deteriorates rapidly.

The method as devised by Bergeim, employing the very sensitive color reaction of Herter and Foster (beta-naphtha-quinone-sodium-monosulfonate), is fairly dependable and sensitive, but is objectionable in several respects. In the first place the reaction cannot be used in the presence of phenols or ammonia, which necessitates the separation of the indole from these substances by distillation. Solutions of beta-naphtha-quinone-sodium-mono-

* Published with the permission of the Secretary of Agriculture.

sulfonate deteriorate rapidly, the compound being subject to ready oxidation. At present it is difficult to obtain the reagent upon the open market, although this objection is hardly valid, since the compound could be produced if the demand were prevalent. A more serious objection, and one common to all methods involving the use of the colorimeter, is the question of the expense of the instrument. Many laboratories do not possess a standard colorimeter.

As proposed, the method of Bergeim requires the cumbersome and laborious process of steam distillation for the separation of the indole from the fecal suspensions. Since many substances seem to interfere with the accuracy of the determination it is necessary to repeat the steam distillation process, in the first instance using an alkaline medium and afterwards an acid one. Bergeim points out the use of Folin and Bell's exchange silicate (*permutit*) (7) for the absorption of ammonia, and his results seem to show that it is possible by its use to evade one of the distillations, although the employment of *permutit* following the first steam distillation requires considerable manipulation. In my own experience it has been found possible to remove small quantities of several of the alkylamines with exchange silicate, notably monomethyl- and monoethyl- and dimethyl-amine.

In 1908 Nonnotte and Demanche (5) published a method which proffered the possibilities of being developed into one possessing great simplicity as well as accuracy. They made use of the familiar nitrite color reaction of Baeyer (8) and Nencki (9), which involves the addition of a dilute nitrite solution to an aqueous solution of indole, and following this with a few drops of hydrochloric, sulfuric, or nitric acid. Nonnotte and Demanche specify ten drops of 1 per cent nitrite and four drops of concentrated sulfuric acid to 10 cc. of the centrifuged medium. The intensity of the color, after a given time limit, is compared to a series of standard tubes containing known quantities of indole treated as above.

Hopkins and Cole in 1903 (10) and Herter (11) in 1908 made extensive study of the chromogen of the "urorosein" urine reaction and discovered that indoleacetic acid as well as indole could be responsible for the red color produced when urines containing nitrites were treated with HCl or H₂SO₄. Herter also found that

p-dimethyl-amino-benzaldehyde reacted with indoleacetic acid to give a coloration similar to that with indole. With this in mind it is obvious that Nonnotte and Demanche's use of the nitroso reaction in cultures, freshly centrifuged to relieve turbidity, is fraught with grave danger, since indoleacetic acid (skatole carbonic acid, Salkowski (12)) is reported to have been isolated from cultures of *Bacillus coli* by Hopkins and Cole (10) and putrefactive mixtures by Salkowski (12). Homer (6), in a recent and very exhaustive study of the chromogen of the urochrome and allied reactions, has more clearly identified the precursors of these color changes. For most purposes it should be conceded that, in order to render even the detection of indole in bacterial cultures and other media at all sensitive and reliable, it is necessary to apply the test to the distillate after proper distillation. The limitations for a proper distillation formed the objective of a separate study and the results are reported in another paper (13).

Another fact which was evidently lost sight of by Nonnotte and Demanche is the solubility of nitroso-indole in weakly acid solutions. When a solution, containing a concentration of indole greater than 0.15 mg. per 10.0 cc. of solution, is treated with nitrite and acid the red nitroso-indole compound supersaturates the solution and gradually settles on the side of the container. The discovery that the sensitivity of the nitroso reaction with indole could be increased more than threefold by resorting to a few cc. of either isoamyl (primary) or isobutyl (primary) alcohol at once suggested the value of the test for detection. The alcohol completely extracts the nitroso-indole and rises to the surface, thereby concentrating to a small area the full amount of color. This discovery, together with the result that these solutions of nitroso-indole possess great permanence over long periods of time, led us to believe that the method of Nonnotte and Demanche could be so improved as to furnish one of reliable application.

Separation of Indole from Complex Mixtures.

Technique.—As reported in another study (13) it was found that the method of steam distillation could be abandoned for the more available one of direct distillation, provided recognition was given to the tendency of indole to volatilize more readily from solutions

made alkaline above a certain hydrogen ion concentration and within the limit of no hydrolytic action. The particular range of hydrogen ion concentration which gave complete volatilization of the indole from the distilling flask when 75 per cent of the contents had been driven over, and which showed no indication of loss of indole through destructive action, was from pH 8.5 to 10.5; the highest alkalinity studied was pH 10.5. The point arbitrarily chosen to which all solutions should be adjusted before distilling is pH 9.2. This point was taken in the first place because of the ease of adjusting the reaction of the solution to this intensity of acidity. At pH 9.2 phenol- or cresolphthalein¹ are both at their medium of intensity of clear red-violet color, while thymolphthalein fails to show a visible blue color (the first appearance of color with thymolphthalein is between pH 9.3 to 9.4). In the second place the degree of foaming increases with protein solutions as the alkalinity increases, while at the point chosen very little trouble was experienced. Furthermore, higher alkalinities tend toward harsh hydrolysis of protein material and liberate quantities of ammonia. While small amounts of ammonia were not found to hamper the delicacy of the test in any way, large amounts may just as well be avoided.

The frothing in alkaline solutions may be checked in a large measure by the addition of various compounds, but in the case of my own experience a little care exercised during the distillation was all that was needed. One precaution that was uniformly taken was to seal one end of a glass tube about 6 to 8 mm. in diameter and insert it into the distilling flask with the open end on the bottom of the flask beneath the surface of the liquid and the opposite end resting against the neck of the flask so that it would remain in this position throughout the distillation. A constant flow of vapor is maintained by this form of ebullator and the tendency to foam is diminished. Many of the high boiling point compounds used to reduce foaming are solvents for indole and thereby tend to concentrate it in different regions within the distilling flask. Phenylether as proposed by Mitchell

¹ The color transitions of phenolphthalein and *o*-cresolphthalein occur in approximately the same zone of hydrogen ion concentration. The latter indicator may be used more advantageously in deeply colored media since its color changes are more brilliant than those of phenolphthalein.

and Eckstein (14) gives as satisfactory results as any in solutions where the tendency to foam is abnormally great.

A satisfactory procedure when working with bacterial cultures is to grow them in Florence Pyrex flasks of 300 cc. capacity, employing 100 cc. of medium per flask. Connect the flask with an upright water-cooled condenser so that the discharge of the condensate is rapid and complete. A rubber stopper covered with tin-foil provides a clean and vapor-tight connection between flask and condenser.

Adjustment of Reaction.—The culture or medium containing indole is adjusted by the addition of normal NaOH to the desired degree of hydrogen ion concentration as shown by phenolphthalein and checked by thymolphthalein. This may be accomplished, *where extreme accuracy is desired*, by pipetting 10 cc. of the medium into a test-tube, adding five drops of the 0.02 per cent indicator solution, and then adding alkali drop by drop until the depth of color matches the depth of color produced by the same quantity of the indicator in 10 cc. of a standard buffer mixture. This standard buffer mixture may be prepared to represent a true hydrogen ion concentration of pH 9.2, or any other decided upon for the distillation, by following the method proposed by Clark and Lubs (15). If the 10 cc. of medium represent one-tenth of the total volume to be distilled, then by multiplying the number of drops or cc. of alkali required for the one-tenth portion by nine, the quantity of alkali necessary for the remaining 90 cc. to reach the same pH will be determined. A burette is convenient for holding and measuring the alkali. The 10 cc. portion containing the indicator and alkali may be returned to the flask for distillation.

If no standard buffer mixture is at hand it is possible to adjust the reaction directly in the flasks, and *this is to be recommended in all cases of laboratory routine and when working with pathogenic organisms*. All that is necessary in this case is to run normal alkali into the solution until phenolphthalein shows a full red and thymolphthalein shows no blue. One drop of indicator as it falls on the surface of the medium is sufficient to indicate these pH values when observed at the point of contact. The writer has successfully used a porcelain-spot test-plate for determining the reaction. Two or more drops of media and one drop of the 0.02 per cent indicator solution give excellent definition.

The distillation is continued until all but about 10 cc. has been driven over, the distillate being collected in a 100 cc. volumetric flask and made up to the mark. This represents the total indole from the culture.

Determination of Indole.

Preparation of Standards.—10 mg. of pure indole are dissolved in 100 cc. of distilled water, warming the water slightly if necessary. A set of 10 test-tubes $\frac{1}{2}$ inch in diameter and of uniform thickness and color are arranged and numbered to receive portions of the above indole standard delivered from a burette graduated in 0.1 cc. (0.01 cc. if obtainable). It has been found useful to arrange the following concentrations in the tubes: 0.02, 0.04, 0.06, 0.08, 0.10, 0.12, 0.14, 0.16, 0.18, and 0.20 mg. of indole respectively. Water is now added to the tubes to approximate a total of 10 cc. To each tube are added two drops of a 1.0 per cent solution of sodium nitrite (NaNO_2) and five drops of concentrated sulfuric acid. Each tube is carefully shaken by inversion. After standing for about 5 minutes each tube is extracted with three portions (3 cc. per portion) of isoamyl or isobutyl alcohol. These three extractions are combined in one test-tube and made up to exactly 10 cc. with the pure extractant; this represents the total nitroso-indole from the respective indole standards. Both isoamyl and isobutyl alcohols, under the conditions of the test, form clear strata above the water portion without emulsification and can be drawn off by means of a pipette, the stem of which is bent at right angle and possesses a soft rubber tube. The test-tubes can be marked at the 10 cc. volume point.

These alcoholic nitroso-indole standards are thoroughly reliable for a working period of a week or longer. They may be placed in subdued light when not in use. They have been observed for a period of 2 months in strong light and the only change observed was a slightly increased detail of the absorption bands. No new bands were noticed; neither was there shifting of the old. No change was apparent to the eye.

Details of Test.—An aliquot of the distillate from the indole separation is pipetted into a test-tube of convenient size; the aliquot may be 10, 15, or 20 cc., or larger, just so that no more

than 0.20 mg. of indole is present in it. If the quantity of indole is known to be small then a larger aliquot is necessary, since there must be at least 0.01 mg. in order to compare with the above mentioned standards. Of course any similar set of indole standards may be made up, employing different concentrations. For instance Nonnotte and Demanche advised the use of the drop system in measuring the indole solutions for the nitroso-indole standards. This latter system is obviously very faulty, and was found to yield varying results.

The aliquot of distillate is measured into a test-tube and two drops of 1.0 per cent NaNO_2 solution are then added, this being followed by five drops of concentrated sulfuric acid. The test-tube is shaken and allowed to stand about 5 minutes for the nitroso reaction to approach equilibrium. It is then extracted with three portions (3 cc. per portion) of isobutyl or isoamyl alcohol as before, and each portion is drawn off with a pipette and run into a test-tube of the same dimensions and quality as those which hold the standards. This tube should previously be marked at the 10.0 cc. volume point, so that after adding the last portion of extraction it may be made up to the mark and compared with the standards. It is advisable to run duplicates on the distillates at the same time. With a little experience it is possible to interpolate very accurately between successive 0.02 mg. standards by matching the relative intensity.

If it is desired to work with smaller portions of cultures or biological products the same procedure as outlined above may be followed, with the added precaution of diluting the mixture or culture to 100 cc. before distilling. In this case it may be necessary to work with the entire distillate, when a small separatory funnel will be found convenient.

Comparison of the Nitroso-Indole Method with the Beta-Naphtha-Quinone-Sodium-Monosulfonate Method as Applied by Bergeim.

2.5 mg. of Eimer and Amend indole were dissolved in 200 cc. of distilled water. This was used as standard for the comparative determinations, portions of which were carefully measured into tubes from which the contained indole was extracted. Chloro-

form, as suggested by Bergeim, was used as an extractant when following his method. Isobutyl (primary) alcohol was used to extract the nitroso-indole. A 1.0 cc. solution of indole containing 0.10 mg. was diluted, treated with beta-naphtha-quinone-sodium-monosulfonate² and extracted with chloroform, and the total chloroformic extract was made up to 15 cc. This was used as

TABLE I.

Description of experiment.	Indole.			
	Bergeim method.		Zoller method.	
	In portion.	Found.	In portion.	Found.
	mg.	mg.	mg.	mg.
15 cc. portions of prepared indole solution	0.1375	{0.1362 0.1365	0.1375	{0.1350 0.1350
10 cc. portions of prepared indole solution	0.1250	{0.1246 0.1248	0.1250	{0.1300 0.1250
200 cc. culture of <i>B. coli</i> grown on medium for 30 hrs.; 100 cc. by Bergeim method, 100 cc. by Zoller method*		{0.465 0.468		{0.478 0.476
10 cc. portion of preparation + 1.0 per cent of phenol			0.1250	{0.1275 0.1250
10 cc. portion + 1.0 cc. of 0.1N NH ₃ .			0.1250	{0.1300 0.1250

* Time required for Bergeim's separation and test, 3.5 hrs.; for Zoller's separation and test, 1.0 hr.

standard in a Duboseq colorimeter for all determinations which were based upon Bergeim's method.

As a further test of the practicability of the proposed method for estimating indole, a culture of *Bacillus coli* (Lab. No. fg) was grown in 500 cc. of a medium of 1.0 per cent Difco peptone, 0.5

² The writer uses this opportunity to thank Dr. O. Bergeim, of the Jefferson Medical College, Philadelphia, Pa., for a liberal quantity of beta-naphtha-quinone-sodium-monosulfonate furnished for indole determinations.

per cent K_2HPO_4 , and 0.1 per cent dextrose for 30 hours. Two portions of 100 cc. each were simultaneously removed from this culture, and the indole was removed from one portion by Bergeim's double distillation method, and from the other portion by the scheme involving adjustment of reaction and distillation as outlined in this paper. The indole was determined in portions of the separate distillates and calculated to milligrams of total indole in 100 cc. of the culture. The results are presented in Table I.

DISCUSSION.

It should be remembered that skatole is not an infringing danger to the success of the proposed method. Fischer (16) and Brieger (17) as well as Salkowski pointed out that nitroso-skatole, if formed, was white and insoluble in the acid solution in which it is formed. The writer has found it to be only slightly soluble in isobutyl alcohol, and it did not give absorption in the visible portion of the spectrum. It seems likely therefore that skatole would not interfere in the determination.

Indoleacetic acid, as previously mentioned, reacts similarly with nitrous acid to give a red nitroso-indoleacetic acid. This may be responsible for the "cholera-red" reaction of Nencki (18) as well as the urosein. Since indoleacetic acid is non-volatile with water vapor it is eliminated as a danger to the accuracy of the test.

It is very likely that the formation of nitroso-indole follows the reaction

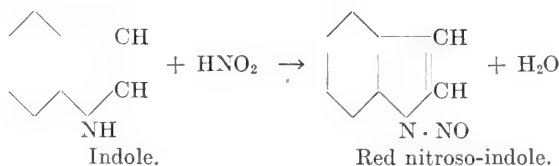

Nitroso-indole is readily soluble in methyl alcohol and can be crystallized from it in flesh-colored, shiny leaves or flakes. These seem to remain unchanged for long periods of time and suggest the possibility of preparing standards directly from the purified crystals. The crystals melt at 170°C . (uncorrected), with decomposition.

The nitroso-indole reaction, when supplemented with the alcohol extraction, becomes an exceedingly sensitive and convenient way of detecting the presence of indole. The relative sensitivity of Herter's naphthaquinone reaction and the nitroso reaction were found to be respectively 1:2,000,000 and 1:1,500,000. The extraction of the excess of the reagent in the former case by the chloroform reduces noticeably its sensitiveness. It is also necessary that the naphthaquinone reagent be freshly prepared in order to secure best results. With the nitroso-indole test the only precautions necessary are the proper concentrations of nitrite solution and acid. Excess nitrite or acid tends to displace the sensitiveness. The most effective working limits for the reaction as applied seem to be those given in the above method. It is important to know that the alcoholic solutions of nitroso-indole are much more stable than the aqueous solutions.

Recently a number of investigators have used the vanillin test proposed by Steensma (19). Blumenthal (20) reported in 1909 a very careful survey of the color reaction between various aromatic aldehydes, including vanillin, and indole and skatole. While many of these aldehydes yield beautiful color reactions with indole and skatole, their sensitiveness is greatly impaired because of the high reactivity of the aldehydes for other compounds such as phenols and ammonia. The danger of performing the vanillin test in cultures of organisms is at once apparent. The yellow-orange color which develops when indole and vanillin are brought together in acid solution is very readily masked, as well as duplicated by other substances. When the test is applied to the indole distillate from such cultures its delicacy is only slightly more enhanced and even then is not so discriminating between the homologues as the nitroso-indole, *p*-dimethyl-amino-benzaldehyde, or naphtha-quinone-monosulfonate reactions. The arguments brought forward for its extreme delicacy are mainly fallacious in view of these facts. The writer, therefore, believes that a note of warning should be sounded against its promiscuous use in bacteriological work.

The rate at which the equilibrium of the nitroso-indole reaction is reached depends upon the factors of concentration and temperature. It is notable that with temperatures above normal, 30 to 90°C., the full depth of color is obtained in a few seconds. Higher

temperatures tend to destroy the colored chromogen when in aqueous solutions. In pure isobutyl alcohol the color is not destroyed even after several hours' heating at temperatures around 100°C. Inasmuch as indole is volatile with water vapor, the rate being chiefly dependent upon temperatures, it is unwise to conduct the test or determination at temperatures above 30°C.

It seems that the features of readily available reagents and simplicity and speed of performance are in themselves sufficient to recommend the proposed method to any one. In addition to these points it is well to consider the fact that indole occurs in biological media in the extremes of concentrations and that the foregoing method as devised is particularly adapted to measure these extremes. Since the evidence reported shows it to check favorably with the best from the standpoint of accuracy and its sensitiveness to be less affected by contaminating substances, it should find very general application.

SUMMARY.

1. The limitations of the nitroso-indole reaction of Baeyer have been studied with the idea of improving and standardizing the Nonnotte and Demanche application of it to the quantitative determination of indole.

2. The method evolved is simple, reliable, and rapid, and requires only the reagents and apparatus common to most laboratories.

3. The indole is separated from the parent mass by one direct distillation. The limitations of this distillation have been reported elsewhere (13) and are dependent upon the hydrogen ion concentration of the medium.

4. Use of the nitroso reaction, when accompanied by an alcohol solvent, for testing the distillate from biological media for the presence of indole is advocated. A warning is sounded against the use of the vanillin-acid test for indole.

BIBLIOGRAPHY.

1. Herter, C. A., and Foster, M. L., *J. Biol. Chem.*, 1906-07, ii, 267.
2. Gorter, E., and de Graff, W. C., *Compt. rend. Soc. biol.*, 1908, lxiv, 402.
3. Bergeim, O., *J. Biol. Chem.*, 1917, xxxii, 17.
4. von Moraczewskii, V., *Z. physiol. Chem.*, 1908, lv, 42.
5. Nonnotte, M., and Demanche, R., *Compt. rend. Soc. biol.*, 1908, lxiv, 658.
6. Homer, A., *J. Biol. Chem.*, 1915, xxii, 345.
7. Folin, O., and Bell, R. D., *J. Biol. Chem.*, 1917, xxix, 329.
8. Baeyer, A., *Ann. Chem. u. Pharm.*, 1870, Suppl. 7, 56.
9. Nencki, M., *Ber. chem. Ges.*, 1875, viii, 1517.
10. Hopkins, F. G., and Cole, S. W., *J. Physiol.*, 1903, xxix, 451.
11. Herter, C. A., *J. Biol. Chem.*, 1908, iv, 253.
12. Salkowski, E., *Z. physiol. Chem.*, 1883-84, viii, 425.
13. Zoller, H. F., *J. Biol. Chem.*, 1920, xli, 37.
14. Mitchell, H. H., and Eekstein, H. C., *J. Biol. Chem.*, 1918, xxxiii, 373.
15. Clark, W. M., and Lubs, H. A., *J. Bacteriol.*, 1917, ii, 1.
16. Fischer, E., *Ann. Chem. u. Pharm.*, 1886, ccxxxvi, 137.
17. Brieger, L., *Ber. chem. Ges.*, 1879, xii, 1985.
18. Nencki, M., *Ber. chem. Ges.*, 1901, xxxiv, 201.
19. Steensma, F. A., *Z. physiol. Chem.*, 1906, xlvii, 25.
20. Blumenthal, F., *Biochem. Z.*, 1909, xix, 525.

INFLUENCE OF HYDROGEN ION CONCENTRATION UPON THE VOLATILITY OF INDOLE FROM AQUEOUS SOLUTION.*

BY HARPER F. ZOLLER.

(From the Research Laboratories of the Dairy Division, Bureau of Animal Industry, United States Department of Agriculture, Washington.)

(Received for publication, November 25, 1919.)

The methods in common practice for the separation of indole from biological mixtures stipulate the addition of either acid or alkali of strong concentration to the flasks of suspended material from which the indole is to be driven by steam distillation or direct boiling. The purpose of such treatment is, doubtless, to prevent the volatilization of interfering substances by neutralizing them *in situ*. Not infrequently one finds the direction to double distill; *i.e.*, distill first from alkali with steam and then acidify the distillate and redistill with steam or *vice versa*. In the procedures published in the literature no apparent thought is given to the final reaction of the medium, or to the reserve alkalinity or acidity which it possesses. No attempt is made to identify the concentration of the acid or alkali with its chance effect upon the indole molecule, either internally or externally. It is the purpose of this paper, therefore, to report the results of a study aimed toward the defining of standard conditions for the separation of indole from various media. In projecting the study two objectives were sought. One was to determine whether steam distillation could be safely abandoned for direct distillation. The other was to ascertain whether or not the conditions for such a separation would destroy the indole molecule.

Since indole is an aromatic imine possessing basic properties—although the degree of basicity is greatly modified by the orien-

* Published with the permission of the Secretary of Agriculture.

tation within the double-ring structure (as proved by the catalytic reduction of indole into *o*-toluidine and methane)—(1) we should expect it to form associated compounds with strong acids. In this expectation we are not disappointed, for the compounds indole nitrate (2) and indole hydrochloride (3) have been isolated. The methods of isolation and their properties suggest that these compounds are very loosely associated. The fact that indole may be removed from a strong acid solution by steam, when proper cautions are observed, tends to justify this assumption.

As previously mentioned, the concentration of acid employed in the isolation of indole has been rather high, although varying through a wide range. It is well known that a hydrogen ion concentration maintained at 1.0×10^{-6} is amply sufficient to prevent the volatilization of ammonia from aqueous solutions. In many instances in the practice of distilling indole with water vapor the hydrogen ion concentration is in excess of 1.0×10^{-1} . Now it was thought that the rate at which indole volatilized from aqueous solutions, adjusted to definite initial hydrogen ion concentration, might be of value in defining the conditions under which the distillation of indole could be safely conducted.

One could anticipate, inasmuch as indole possesses feebly basic properties, that it would volatilize more freely from an alkaline solution. To what extent the alkalinity might be carried without producing disintegration of the indole molecule has never been, to the writer's knowledge, published. This might be roughly ascertained by determining the indole distilled and that remaining in the distillation flasks after a series of diverging alkalinities had been run. This, of course, would necessitate the assumption that the products resulting from the action of alkali on indole do not act like indole toward the test reagents. Such an assumption is only partially justifiable. In very strong alkali solutions indole converts first to indoxyl and thence to indigo blue, following the course of a true oxidation. Neither of these substances would confuse the nitroso test for indole.

With these considerations in mind and with a rather rapid method of determining indole at hand (4), the following study was made.

Experimental A.

Twelve Florence-shaped, 250 cc., Pyrex flasks were provided. Into each were poured 90 cc. of distilled water containing 1.0 mg. of indole. The hydrogen ion concentration of each solution was initially adjusted to the respective pH values, the term $\text{pH} = \log \frac{1}{\text{hydrogen ion}}$ being that adopted by Sørensen (5).

Flask No.	pH	Indicator.	Flask No.	pH	Indicator.
A	1.0	Thymol blue.	G	6.0	Bromocresol purple.
B	2.0	" "	H	7.0	Phenol red.
C	3.0	Bromophenol blue.	I	7.6	" "
D	4.0	" "	J	8.0	Cresol "
E	4.4	Methyl red.	K	9.0	Cresolphthalein.
F	5.0	" "	L	10.0	Thymolphthalein.
			M	10.5	"

In adjusting the reaction of the solutions use was made of a 0.1 N solution of HCl and 0.1 N disodium hydrogen phosphate ($\text{Na}_2\text{HPO}_4 \cdot 2\text{H}_2\text{O}$) for the range of pH 1.0 to 8.0, while for the range of pH 9.0 to 10.5 a 0.1 N NaOH solution in conjunction with the Na_2HPO_4 solution. Burettes carried the solutions mentioned. The indicators developed and reported by Clark and Lubs (6) were employed for accurately determining the initial pH points. In addition, thymolphthalein served to determine the concentrations pH 10.0 and 10.5. The total volume of solution within the flasks was finally adjusted to 100 cc. with distilled water. They were then placed upon an iron wire gauze over a free flame of a Bunsen burner and the contents directly distilled through glass connections into an upright, short tube (water jacket 7.0 inches) condenser. The condensate was collected in 50, 25, and 15 cc. portions, and in the noted order, graduated cylinders acting as collectors. The quantity of indole in each portion was determined by the nitroso-indole method (4). The amount of indole remaining in the flasks was also determined in the same manner.

It should be mentioned that a glass tube ebullator was placed in each flask before distilling in order to insure a constant flow of vapor into the condenser. The more alkaline solutions, pH 9.0 to 10.5, were carefully watched to prevent foaming. It was undesirable in this study to add chemical foam reducers since the majority of them (amyl, octyl, and heptyl alcohol and phenyl ether) are solvents for indole and immiscible with water; hence their use would introduce the question of effect upon the volatility of indole.

The results of the experiment above are included in Table I. The values in the last column, expressing the per cent of volatility of indole from aqueous solution at different pH values are shown graphically in Fig. 1.

TABLE I.

Reaction of solution.	Indole in aqueous solution.					
	Flask.	50 cc.	25 cc.	15 cc.	Flask.	Distilling in first 75 cc.
<i>pH</i>	<i>mg.</i>	<i>mg.</i>	<i>mg.</i>	<i>mg.</i>	<i>mg.</i>	<i>per cent</i>
1.0	1.000	0.610	0.205	0.13	0.050	81.5
2.0	1.000	0.590	0.200	0.140	0.065	79.0
3.0	1.000	0.605	0.220	0.125	0.050	82.5
4.0	1.000	0.570	0.205	0.140	0.090	77.5
4.4	1.000	0.585	0.190	0.125	0.100	77.5
5.0	1.000	0.585	0.210	0.105	0.095	79.5
6.0	1.000	0.690	0.205	0.080	0.030	89.5
7.0	1.000	0.785	0.185	0.025	0.000	97.0
7.6	1.000	0.855	0.130	0.015	0.000	98.5
8.0	1.000	0.860	0.135	0.010	0.000	99.5
9.0	1.000	0.906	0.090	0.000	0.000	99.6
10.0	1.000	0.915	0.086	0.000	0.000	100.1
10.5	1.000	0.912	0.084	0.000	0.000	99.6

Since it might be construed that the above values would not be approached in complex media, although such media possessed corresponding pH values, it was, therefore, desirable to repeat the above experiments, employing a protein suspension in lieu of the aqueous solutions of indole. Consequently a medium was prepared which possessed approximately the following compositions: 2.0 per cent Difco peptone, 0.1 per cent dextrose, and 1.0 per cent K_2HPO_4 .

50 cc. of this medium were measured into each of the above flasks. 1.0 mg. of indole was added in the form of 10 cc. of a 0.1 per cent solution. The corresponding pH values were adjusted in the various flasks, eliminating pH 4.4 and 7.6. The final volume of solution was made up to 100 cc. and distilled as in the previous study. Flasks holding solutions at pH 9.0, 10.0, and 10.5 received 1.0 cc. of phenylether each to prevent excessive foaming. The results are reported in Table II.

TABLE II.

Reaction of suspension.	Indole in protein suspension.			
	Flasks.	50 cc.	25 cc.	Distilling in first 75 cc.
<i>pH</i>	<i>mg.</i>	<i>mg.</i>	<i>mg.</i>	<i>per cent</i>
1.0	1.000	0.585	0.205	79.0
2.0	1.000	0.600	0.200	80.0
3.0	1.000	0.595	0.210	80.5
4.0	1.000	0.595	0.205	80.0
5.0	1.000	0.590	0.220	81.0
6.0	1.000	0.620	0.240	86.0
7.0	1.000	0.725	0.200	92.5
8.0	1.000	0.875	0.115	99.0
9.0	1.000	0.890	0.105	99.5
10.0	1.000	0.910	0.080	99.0
10.5	1.000	0.905	0.095	100.0

No attempt was made herein to determine the distribution of indole beyond the first 50 and 25 cc. portion of distillate. It was assumed that no greater destruction of indole would occur in the mixed medium than in the purer solutions. Considerable ammonia was evolved from the last two flasks. The rate of volatilization of the indole was plotted against the pH and is reproduced in Fig. 2.

Experimental B.

In order to further establish the rate of volatility another set of aqueous solutions of indole was prepared according to methods followed under A, except that 2.0 mg. of indole were dissolved in a total volume of 200 cc. The range of pH was, with the exception of 4.4 and 7.6, the same as in Table I. Each solution of indole was placed in a gas-washing bottle possessing gas-tight junctures. This bottle was in turn set into a water bath (the water bath was maintained at 50°C. throughout the experiment) and then connected to a train of three other bottles B, C, and D. Bottle B contained distilled water, C 50 per cent NaOH, and D an improvised glass gas meter so constructed that 20 cc. of air were passed at each dump. Communication was now established between the bottle carrying the indole solution and the vacuum line, and the rate of suction so adjusted that 1,000 cc. of CO₂-free air passed through the indole solution each minute for 60 minutes.

After aerating each solution for 1 hour they were again adjusted to 200 cc. and the indole content was determined in an aliquot. The per cent of loss of indole is plotted against the pH and is represented in Fig. 3.

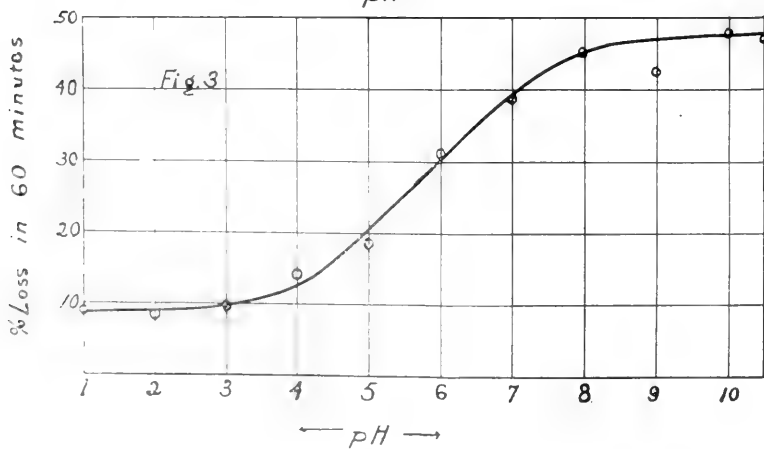
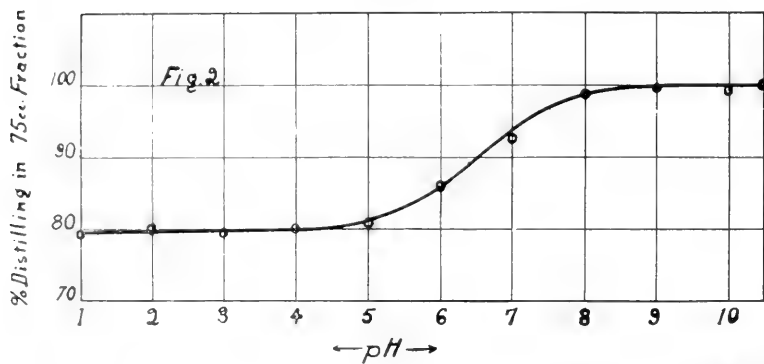
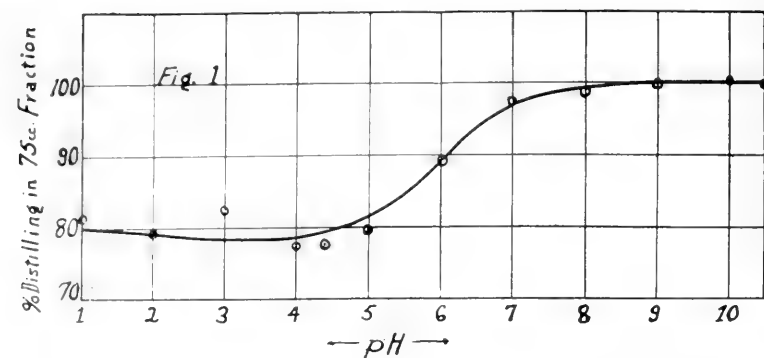

DISCUSSION.

It is clear from the published results that the tendency is towards an increased volatility of indole from solutions possessing a hydrogen ion concentration of 1.0×10^{-8} and less; or in terms of Sørensen's nomenclature, pH 8.0 to 10.5. There was no reason for the studying of acidities or alkalinities of a higher order, since the ranges of those investigated are extreme enough for all practical purposes.

The comparative regularity of the distillations as performed, and the completeness of the volatilization of the indole in the first 75 cc. of distillate from aqueous solutions possessing an initial pH of 8.0 and higher, suggest that the practice of steam distillation is unnecessary. A mixture containing indole and adjusted to a pH of 9.0 to 10.0 will not volatilize any phenols, but will permit some ammonia, skatole, and other volatile bases to be driven over with water vapor. Ammonia may be removed by shaking out with exchange silicate (permutit) or yellow mercuric oxide (7), while permutit will also remove small amounts of certain alkylamines. Neither of these absorbents will remove indole or skatole. A further test pointing to the regularity of the distillation was conducted by distilling 100 cc. of a solution containing 1.0 mg. of indole, buffered at an initial pH of 9.0, from a Duclaux still patterned after that designed by Gillespie and Walters (8). Nine successive 10 cc. portions of the distillate were collected and separately analyzed for indole. The ninth fraction was free from indole while the eighth contained less than 0.01 mg.

The application of this principle of direct distillation of indole from crude mixtures has been practiced in connection with some bacteriological work in this laboratory and with satisfying results. The method as applied is discussed in another paper (4). It may be remarked that the method is much preferable to the cumbersome one of steam distillation, especially when dealing with pathogenic organisms.

SUMMARY.

1. The range of most rapid volatilization of indole from the aqueous solutions studied is from pH 8.0 to 10.5.

2. Hydrogen ion concentrations greater than 1.0×10^{-6} caused a decrease in volatility of indole with water vapor, probably due to the formation of weakly associated combinations between indole and acid in aqueous solution.

3. Hydrogen ion concentrations of the order of pH 10.5 have no appreciable destructive action on the indole molecule under the conditions of the study.

4. The results from the experiments performed suggest that the practice of steam distillation can be supplanted by direct distillation with equal accuracy when the reaction of the solution is taken into account. This direct method of distillation has been practiced in a routine investigation in this laboratory and found reliable and commendable.

BIBLIOGRAPHY.

1. Carrasco, O., and Padoa, M., *Atti r. Accad. Lincei rendic.*, 1906, xv, pt. 1, 699.
2. Salkowski, E., *Z. physiol. Chem.*, 1884, viii, 425.
3. Baeyer, A., *Am. d. Cherner. Pharm.*, 1870, Suppl. 7, 56.
4. Zoller, H. F., *J. Biol. Chem.*, 1920, xli, 125.
5. Sørensen, S. P. L., *Ergebn. Physiol.*, 1912, xii, 393.
6. Clark, W. M., and Lubs, H. A., *J. Bacteriol.*, 1917, ii, 1.
7. Francois, M., *J. Pharm. et Chim.*, 1907, xxv, 517.
8. Gillespie, L. J., and Walters, E. H., *J. Am. Chem. Soc.*, 1917, xxxix, 2031.

AVAILABILITY OF CARBOHYDRATE IN CERTAIN VEGETABLES.

BY W. H. OLMSTED.

(From the Laboratories of the Departments of Medicine and of Biological
Chemistry, Washington University School of Medicine,
St. Louis.)

(Received for publication, November 11, 1919.)

The extensive use of certain vegetables of low carbohydrate content, such as spinach, cabbage, cauliflower, and lettuce, in the diet of patients suffering from diabetes during the determination of their carbohydrate tolerance makes it desirable to know with considerable accuracy the amount of sugar-forming substance which these foods contain. The recorded analyses permit only a doubtful calculation of the desired information, because among other reasons much of the carbohydrate is "fiber" which presumably is not digested or absorbed by man; the availability of the starch may be more or less uncertain depending upon the extent to which it is liberated from its protecting cell structure by cooking, mastication, and digestion; and because certain organic acids, which by hydrolysis and reduction methods are not determined as carbohydrate, may form sugar after absorption from the intestine. Furthermore, published analyses¹ usually give carbohydrate as determined only by difference, and the combined errors thus fall on this constituent. While such figures represent more or less correctly total carbohydrate, with or without fiber, there is no assurance that they indicate the amount of carbohydrate available to the body when the materials are eaten. Thus, Lusk² fed cauliflower to a phloridzined dog without detecting sugar production, yet by analysis cauliflower contains 3.7 per cent carbohydrate.

¹ Atwater, W. O., and Bryant, A. P., *U. S. Dept. Agric., Bull. 28*, revised, 1906.

² Lusk, G., *Am. J. Physiol.*, 1910-11, xxvii, 467.

It was, therefore, decided to determine by more direct methods the sugar-forming material in those vegetables which are commonly used in the dietaries of diabetics in order to be able to calculate more exactly the available carbohydrate in such diets.

Four methods have been used for the determination of carbohydrate in foodstuffs. First is the method most commonly used by which carbohydrate is calculated by difference after direct determination of fat, protein ($N \times 6.25$), ash, water, and insoluble fiber; second, direct hydrolysis by mineral acid and the subsequent determination of reducing sugar; third, preliminary hydrolysis of starch by diastase to dextrins, maltose, and glucose, followed by copper reduction and determination by polariscope or by acid hydrolysis for the conversion to glucose which is then determined by reduction; and fourth, analysis by means of the phloridzinated animal. We have used the last two methods named.

The use of the phloridzinated dogs should give results indicating the total available sugar-forming substance, including sugar formed by such substances as protein and organic acids; while the results of the diastase method should indicate only reducing sugars, preformed, and from the hydrolysis of starch.

Analysis in Vitro by Diastase and Copper Reduction.

The direct hydrolysis of the vegetable material by boiling hydrochloric acid is objectionable because of the hydrolysis of the indigestible fiber and because as shown by Davis and Daish³ 5 or 6 per cent of the maltose may be decomposed and lost.

The milder and more selective action of a diastase as the hydrolytic agent for the starch seems therefore preferable, and has been used for our analyses. Of the commercial diastases available, that of the *Aspergillus oryzae*, the "taka-diastase," proved the most satisfactory, in that hydrolysis was more complete. Results with a 10 per cent extract of malt as recommended in the official methods⁴ gave only 90 to 95 per cent with pure starch. Davis and Daish³ used taka-diastase successfully in their determinations of starch in certain leaves.

³ Davis, W. A., and Daish, A. J., *J. Agric. Sci.*, 1914, vi, 152.

⁴ *J. Assn. Offic. Agric. Chem.*, 1916, ii, pt. 1, 110.

For the determination of the sugar formed by the action of diastase, Davis and Daish used the combined methods of reduction and optical activity of the solutions. We have preferred to employ a secondary hydrolysis of the maltose and any residual polysaccharide by heating with a minimum concentration of acid and to determine the resulting glucose by copper reduction. While this acid hydrolysis probably leads to some decomposition of sugar, the loss under the conditions used is not greater than about 2 per cent and is probably within the limit of error of other stages in the procedure. The acid hydrolysis was carried out on the individual portions taken for analysis in centrifuge tubes placed in boiling water bath under which condition there is less destruction of sugar than occurs in boiling with a reflux condenser.

The principles in the determination were: The thorough trituration and maceration of vegetable samples; the action of 0.1 gm. of taka-diaastase on watery samples at 37°C. for 18 hours; filtration, hydrolysis, and the determination of glucose by Fehling's solution, using Bertrand's method for titration of cuprous oxide.

Procedure.

Samples of the vegetables were carefully selected, put through the finest food chopper, and 20 to 50 gm. weighed out, care being taken to retain the water squeezed out in grinding. These samples were put into a flask with reflux condenser and boiled on a hot plate 1 or 2 hours in 100 to 150 cc. of water. After cooking the sediment was macerated to a paste in a mortar. The only vegetable which offered any difficulty was lettuce and it was found impossible to macerate the leaves, even after prolonged boiling. After combining mother liquor and paste, each sample was washed into a 250 cc. flask and boiled again in a water bath 15 minutes, then cooled to 37°C., and 0.1 gm. of taka-diaastase was added to each flask. All samples were incubated 17 hours at 37°C. with a few drops of toluene as a preservative. After incubation the flasks were made up to volume, well shaken, and 100 cc. taken. 5 cc. of a molecular solution of neutral lead acetate were added to precipitate tannins and gums. Samples were filtered, the filtrate being tested with lead for completeness of precipitation. 10 cc. of filtrate—equaling 9.52 cc. of the original—were taken for determination.

The hydrolysis of sugars, reduction of copper, and the titration by Bertrand's method were done in 50 cc. centrifuge tubes.⁵ To 10 cc. of the

⁵ Schaffer, P. A., *J. Biol. Chem.*, 1914, xix, 285.

TABLE I.

Analysis of Starch by Taka-Diastase and Hydrolysis.

Two samples of Kahlbaum's arrowroot starch, dry weight 0.88 gm., were washed into 250 cc. volumetric flasks with 150 cc. of water. Gelatinized 15 minutes in boiling water bath; cooled to 37°C. and 0.1 gm. of commercial taka-diastase added. Samples incubated at 37° for 20 hours.

100 cc. of starch-diastase mixture were taken to which were added 5 cc. of a molecular solution of neutral lead acetate.

10 cc. of filtrate, representing 9.52 cc. of the original, were taken for determination (36.85 mg. of dextrose).

Samples hydrolyzed 2½ hrs., concentration of acid 0.7 N.

0.01 N permanganate.	Copper.	Copper corrected for blanks.	Glucose.	Theoretical.
cc.	mg.	mg.	mg.	per cent
31.3	79.3	73.2	36.9	100.1
31.2	79.0	72.9	36.8	99.8
31.0	78.5	72.4	36.5	99.0
31.4	79.4	73.3	37.0	100.4

TABLE II.

Summary of Analyses by Taka-Diastase.

Vegetable.	Weight of the sample.	No. of samples.	Average glucose in aliquot (9.52 cc.) samples.	Average glucose in samples.	Carbohydrate as glucose.
	gm.		mg.	gm.	per cent
Potato.....	5	6	35.5	0.930	18.6
Lettuce.....	50	4	18.9	0.495	1.0
Cabbage.....	20	4	33.5	0.877	4.38
Cauliflower.....	30	6	32.1	0.840	2.80
Cabbage, thrice boiled.....	30	5	4.7	0.123	0.4
Cauliflower, " ".....	30	6	10.2	0.267	0.8

TABLE III.

Analyses of Vegetables by Taka-Diastase and by Atwater and Bryant Compared.

	Taka-diastase.	Atwater and Bryant.
Cabbage.....	4.4	4.5
" thrice cooked.....	0.4	
Cauliflower.....	2.8	3.7
" thrice cooked.....	0.8	
Lettuce.....	1.0	2.2

filtrate were added 2 cc. of 7 N hydrochloric acid and water to give a volume of 20 cc. The final concentration of acid was thus 0.7 N. The tubes were placed in a gently boiling water bath 2½ hours. After hydrolysis the acid was almost neutralized with a measured amount of strong sodium hydroxide, 20 cc. of mixed Fehling's solution were added, and the tubes heated in a boiling water bath exactly 10 minutes. Tubes were centrifuged 3 minutes, the excess Fehling's solution was decanted, and cuprous oxide washed twice with 20 cc. of water, centrifuging and decanting each time. After decanting following the last washing, copper was dissolved in 1 to 2 cc. of strong ferric sulfate-sulfuric acid and titrated with 0.04 N potassium permanganate solution. Blanks were always run on 0.1 gm. of taka-diastrase and on the mixed Fehling's solution, the titration of blanks being deducted from titration of cuprous oxide of the sample. The number of cc. of 0.04 N permanganate used multiplied by 2.54 gives the mg. of glucose present in 9.52 cc. of sample. The Bertrand titration was checked by titrating solutions of pure anhydrous glucose.

The use of centrifuge tubes simplifies the process considerably but limits the amount of mixed Fehling's solution that can be used. Experiments showed that 20 cc. of mixed Fehling's solution gives accurate results when between 30 and 40 mg. of dextrose are present. So in the determinations the amount of the sample was so arranged as to give amounts of dextrose within these limits as near as possible.

This method applied to pure, dry, arrowroot starch gave results shown in Table I. As applied to potato, cabbage, cauliflower, and lettuce the method gave results shown in Table II.

The results of analyses of cabbage, cauliflower, and lettuce by the use of taka-diastrase were lower than the accepted analyses of Atwater and Bryant; this was especially true of lettuce. Table III is a comparison of analyses.

The extensive use of thrice cooked cabbage and cauliflower in the treatment of diabetes suggested the analyses of these as prepared in the diet kitchen according to Joslin.⁶ The results show that 60 to 90 per cent of the carbohydrate is lost in the cooking water.

Experiments with Phloridzinized Animals.

The phloridzinization of dogs was conducted after the method of Sansum and Woodyatt;⁷ namely, 48 hours of complete fasting followed by 1 gm. of phloridzin in oil subcutaneously every 12

⁶ Joslin, E. P., *Treatment of diabetes mellitus*, Philadelphia and New York, 1916.

⁷ Sansum, W. D., and Woodyatt, R. T., *J. Biol. Chem.*, 1916, xxiv, 327.

hours and adrenalin, 0.01 mg. per kilo of body weight of animal, subcutaneously every 6 hours.

Sansum and Woodyatt,⁸ Lusk, Janney,⁹ and others have previously used phloridzinized animals as a method of carbohydrate analysis. The animals were kept in clean metabolism cages and catheterized at the end of each experimental period. The urines were preserved with toluene and made up to 1,000 or 1,500 cc.

Nitrogen in urine was determined by Kjeldahl and sugar by the same technique used with plant extracts, clearing with lead acetate, reduction of Fehling's solution, and titration of copper by Bertrand. All urines were read in a polariscope but more accurate D:N ratios were obtained by determining glucose by reduction.

The urine from some dogs gave low glucose figures when calculated from polariscopic readings. In other animals the difference between the results calculated from polariscope and reduction was not great. In Tables IV and V glucose calculated by both methods is given. In Table IV the difference is not very great, but in Table V it is considerable. It will be seen that the D:N ratios calculated from polariscopic values are low, being below 3.00. The presence of levorotatory substances in dog urine is well known and for that reason the determination of glucose by reduction is more accurate. Determinations by polariscope should not be accepted in such work.

Feeding 200 to 500 gm. of bulky vegetables presented some difficulty. The animals refused to eat them of their own volition, but by mixing melted lard with the cooked vegetables and placing the mixture in the animal's mouth, it would always be quickly and often eagerly swallowed. Any liquor left after feeding the bulky material was fed by stomach tube. No vomiting of feedings was experienced. The vegetables were prepared in the same manner used in analysis by diastase, care being taken to boil down water to a minimum. The results are, therefore, for cooked vegetables. If eaten raw the amount of starch digested would doubtless be less.

⁸ Sansum, W. D., and Woodyatt, R. T., *J. Biol. Chem.*, 1916, xxiv, 23.

⁹ Janney, N. W., *J. Biol. Chem.*, 1915, xx, 321.

The extra sugar in all experiments was calculated by the usual method from the average of the starvation D:N ratios of the periods before and after the feeding periods. At the foot of each table are given these ratios. The starvation ratios multiplied by the nitrogen elimination of the feeding periods gives the sugar arising from the protein and this amount subtracted from the sugar excreted during feeding period gives the extra glucose arising from carbohydrate material fed.

The periods where vegetables were fed were made 24 hours in length. It was found that 24 to 30 hours are required for the elimination of all the extra glucose. This slow elimination of extra sugar from such sources of carbohydrate must be taken into account in any experiments where vegetables are fed to phloridzinized animals. In some of the experiments the amount of extra glucose was very small. But the large amount of material, and careful verification of analysis and calculations have convinced us that these amounts of glucose arose from the material fed.

Table IV gives the result from a dog to which was given glucose as a control. The calculation gives a recovery of from 94 to 107 per cent of the sugar fed. It is of interest to note that the sugar fed in Period IV had been racemized by boiling alkaline phosphate solution until the solution was no longer optically active. In the organism, it was, however, converted again quantitatively into dextroglucose. The results indicate satisfactory recovery of available carbohydrate.

Sansum and Woodyatt⁸ obtained from 50 to 75 per cent of dextrose fed by mouth to phloridzinized dogs; Csonka¹⁰ recovered 100 per cent in his experiments.

Table V shows recovery of 17.3 dextrose from 500 gm. of cauliflower or 3.4 per cent of weight. Although Lusk² found no extra sugar after 20 gm. of cauliflower fed to a phloridzinized animal, the small amount of ingested material may well account for his result. By analysis 2.8 per cent of weight of cauliflower was found to be carbohydrate.

¹⁰ Csonka, F. A., *J. Biol. Chem.*, 1916, xxvi, 93.

TABLE IV.

Dog 7 Phloridzinized after 2 Days of Fasting; Weight, 13 Kilos.

10 gm. of sugar given in Period IV were boiled 3 hours in a di-basic phosphate solution of pH 8. The rotation of this solution by polariscope was zero.

The sugar given in Period VII was 10 gm. of pure anhydrous dextrose dissolved in distilled water. Sugar solutions were given by stomach tube.

Period.	Time.	Total N.	Glucose by polariscope.	D: N	Glucose by reduction.	D: N	Extra sugar.	Remarks.
		gm.	gm.		gm.		gm.	
I	1917 Mar. 6, 6 p.m.- 12 m., 6 hrs.	4.58	13.3	2.90	15.0	3.28		
II	Mar. 7, 12 m.- 6 a.m., 6 hrs.	4.01	11.0	2.75	12.7	3.17		
III	Mar. 7, 6 a.m.- 12 n., 6 hrs.	3.84	11.6	3.02	12.2	3.17		
IV	Mar. 7, 12 n.- 6 p.m., 6 hrs.	3.60	19.4	5.18	20.5	5.48	10.7	10 gm. of sugar phosphate mixture given at beginning of Period IV.
V	Mar. 7, 6 p.m.- 12 m., 6 hrs.	3.44	12.3	3.57	12.8	3.72	(10.4)	Extra sugar in parenthesis calculated from polariscope reading.
VI	Mar. 8, 12 m.- 6 a.m., 6 hrs.	3.71	11.2	3.02	12.1	3.26		
VII	Mar. 8, 6 a.m.- 12 n., 6 hrs.	3.65	19.3	5.27	20.2	5.52	9.4	10 gm. of sugar given at beginning of Period VII.
VIII	Mar. 8, 12 n.- 6 p.m., 6 hrs.	3.21	10.0	3.11	11.1	3.45	(8.4)	
IX	Mar. 8, 6 p.m.- 12 m., 6 hrs.	3.32	10.2	3.07	11.2	3.37		
X	Mar. 9, 12 m.- 6 a.m., 6 hrs.	3.48	10.0	2.87	10.8	3.09		

Average D: N of Periods II, III, and VI 3.21.

" " " " VI, IX, " X 3.20.

TABLE V.

*Cauliflower.**Dog 5 Phloridzinized after Fasting; Weight, 14.5 Kilos.*

Period	Time.	Total N.	Glucose by polari- scope.	D: N	Glucose by reduc- tion.	D: N	Extra sugar.	Remarks.
		gm.	gm.		gm.			
	<i>1917</i>							
I	Feb. 13, 6 p.m.- 12 m., 6 hrs.	5.13	21.1	4.11	25.4	4.95		
II	Feb. 14, 12 m.- 6 a.m., 6 hrs.	7.06	20.1	2.85	22.8	3.23		
III	Feb. 14, 6 a.m.- 12 n., 6 hrs.	5.23	13.9	2.66	16.4	3.13		
IV	Feb. 14, 12 n.- 12 n., Feb. 15, 24 hrs.	17.54	64.0	3.65	73.5	4.18	17.3 (15.1)	During first 6 hrs. of Period IV 500 gm. of cauli- flower fed. Ex- tra sugar in parenthesis cal- culated from polariscope readings.
V	Feb. 15, 12 n.- 6 p.m., 6 hrs.	4.74	14.8	3.12	16.8	3.55		
VI	Feb. 15, 6 p.m.- 12 m., 6 hrs.	4.21	12.7	3.02	14.2	3.37		
VII	Feb. 16, 12 m.- 6 a.m., 6 hrs.	4.02	11.7	2.91	13.3	3.31		

Average D: N of Periods II, III, VI, and VII 3.21.

Available carbohydrate 3.6 per cent.

Table VI shows that from 200 gm. of cabbage 10 gm. of glucose were recovered, or 5 per cent of the weight of material fed. By diastase analysis 4.4 per cent was found. The difference is possibly within the limits of the variation in samples, or may indicate the formation of glucose from organic acids or other substances. In the case of both cabbage and cauliflower some-

what lower results were obtained from analysis than by dog method.

TABLE VI.

*Cabbage.**Dog 4 Phloridzinized after Fasting; Weight, 8 Kilos.*

Period.	Time.	Total N.	Glucose by re- duction.	D:N	Extra sugar.	Remarks.
	1917	gm.	gm.		gm.	
I	Jan. 31, 12 n.-6 p.m., 6 hrs.	4.27	13.7	3.20		
II	Jan. 31, 6 p.m.-12 m., 6 hrs.	4.01	13.0	3.22		
III	Feb. 1, 12 m.-6 a.m., 6 hrs.	3.71	14.0	3.77		
IV	Feb. 1, 6 a.m.-6 a.m., Feb. 2, 24 hrs.	12.84	57.6	4.48		
V	Feb. 2, 6 a.m.-12 n., 6 hrs.	2.72	10.0	3.68	10.1	100 gm. of cabbage given at beginning of Period IV; 100 gm. 6 hrs. later. A little lard.
VI	Feb. 2, 12 n.-6 p.m., 6 hrs.	1.75	6.3	3.60		Animal exhausted.

Average D: N of Periods III and VI 3.68.

Available carbohydrate 5 per cent.

Tables VII and VIII show that nearly all the carbohydrates may be washed out of the vegetables by cooking. Snyder and coworkers¹¹ cooked whole heads of cabbage, determining the carbohydrate before and after cooking by the Sachasse method, and found a loss of 34 per cent of carbohydrate and fat. The

¹¹ Snyder, H., Frisby, A. J., and Bryant, A. P., *U. S. Dept. Agric., Bull.* 43, 1897.

TABLE VII.

*Thrice Boiled Cabbage.***Dog 2 Phloridzined after Fasting; Weight, 12.8 Kilos.*

Period.	Time.	Total N.	Glucose by re- duction.	D: N	Extra sugar.	Remarks.
	1917	gm.	gm.		gm.	
I	Feb. 13, 6 p.m.-12 m., 6 hrs.	3.26	14.8	4.54		
II	Feb. 14, 12 m.-6 a.m., 6 hrs.	3.92	16.0	4.08		
III	Feb. 14, 6 a.m.-12 n., 6 hrs.	3.64	14.0	3.84		
IV	Feb. 14, 12 n.-12 n., Feb. 15, 24 hrs.	13.43	50.0	3.72	1.7	During first 6 hrs. of Period IV 300 gm. of thrice boiled cabbage plus a little lard.
V	Feb. 15, 12 n.-6 p.m., 6 hrs.	3.30	13.5	4.08		
VI	Feb. 15, 6 p.m.-12 m., 6 hrs.	3.19	11.8	3.70		
VII	Feb. 16, 12 m.-6 a.m., 6 hrs.	3.11	11.1	3.57		

* Thrice boiled by method of Joslin.⁶

Average D: N for Periods III, VI, and VII 3.70.

Available carbohydrate 0.5 per cent.

greater losses in our analysis are due to the fine division of the sample before cooking.

Table IX shows the recovery of 5.9 gm. of glucose, or 1.2 per cent of weight, from 500 gm. of spinach. It is regretted that we have no analysis of spinach, but the accepted analysis by difference gives 2.3 per cent carbohydrate. The analysis of lettuce by taka-diastrase gave 1.0 per cent carbohydrate. The per cent

as analyzed by difference is 2.2. This data although incomplete would indicate less of available carbohydrate in the green leafy vegetables than earlier analyses indicate.

TABLE VIII.

*Thrice Boiled Cauliflower.**
Dog 6 Phloridzinized after Fasting; Weight, 17 Kilos.

Period.	Time.	Total N	Glucose by re- duction	D: N	Extra sugar.	Remarks.
		gm.	gm.			
I	Feb. 13, 6 p.m.-12 m., 6 hrs.	2.36	17.3	7.3		
II	Feb. 14, 12 m.-6 a.m., 6 hrs.	3.37	13.6	4.0		
III	Feb. 14, 6 a.m.-12 n., 6 hrs.	3.79	13.5	3.55		
IV	Feb. 14, 12 n.-12 n., Feb. 15, 24 hrs.	16.62	59.7	3.59	4.3	500 gm. of thrice boiled cauliflower given during first 3 hours of this period. A little lard added.
V	Feb. 15, 12 n.-6 p.m., 6 hrs.	3.78	12.3	3.25		
VI	Feb. 15, 6 p.m.-12 m., 6 hrs.	3.68	12.4	3.37		
VII	Feb. 16, 12 m.-6 a.m., 6 hrs.	3.46	11.0	3.18		

* Thrice boiled by method of Joslin.⁶

Average D: N of Periods III, V, VI, and VII 3.34.

Available carbohydrate 0.8 per cent.

TABLE IX.

*Spinach.**Dog 1 Phloridzinized after Fasting; Weight, 17 Kilos.*

Period.	Time.	Total N.	Glucose	D:N	Extra sugar.	Remarks.
	1917	gm.	gm.		gm.	
I	Feb. 6, 6 p.m.-12 m., 6 hrs.	3.96	14.8	3.74		
II	Feb. 7, 12 m.-6 a.m., 6 hrs.	4.21	14.0	3.32		
III	Feb. 7, 6 a.m.-12 n., 6 hrs.	4.11	13.5	3.28		
IV	Feb. 7, 12 n.-12 n., Feb. 8, 24 hrs.	16.28	57.0	3.53	5.9	100 gm. of spinach plus a little lard, given during the first 6 hours.
V	Feb. 8, 12 n.-6 p.m., 6 hrs.	3.78	14.5	3.83		
VI	Feb. 8, 6 p.m.-12 m., 6 hrs.	3.67	12.4	3.36		40 gm. of lard given at beginning of this period.
VII	Feb. 9, 12 m.-6 a.m., 6 hrs.	3.17	10.2	3.21		

Average D: N of Periods II, III, VI, and VII 3.29.

Available carbohydrate 1.2 per cent.

SUMMARY.

Vegetables usually used in low carbohydrate diets for diabetic patients were analyzed by the use of diastase and copper reduction, and by feeding to phloridzinized dogs with the following results.

Vegetable.	Available carbohydrate or glucose.		
	Taka- diastase.	Phloridzin- ized dog.	Atwater and Bryant.
	<i>per cent</i>	<i>per cent</i>	<i>per cent</i>
Cabbage.....	4.4	5.0	4.5
" thrice cooked.....	0.4	0.5	
Cauliflower.....	2.8	3.4	3.7
" thrice cooked.....	0.8	0.8	
Spinach.....		1.2	2.3
Lettuce.....	1.0		2.2

It is a pleasure to express my appreciation to Professor P. A. Shaffer, who suggested this work, for his constant interest and help.

ALKALINE RESERVE CAPACITY OF WHOLE BLOOD AND CARBOHYDRATE MOBILIZATION AS AFFECTED BY HEMORRHAGE.

BY ARTHUR L. TATUM.

*(From the Laboratory of Physiological Chemistry and Pharmacology,
University of Chicago, Chicago.)*

(Received for publication, November 17, 1919.)

Hemorrhage as an etiological factor in the causation of hyperglycemia has been for a number of years the subject of considerable investigation. Schenck (1) in 1894 made an extended study of the conditions under which hemorrhage may produce hyperglycemia. He found that when hemorrhage was produced after ligation of the liver vessels there resulted instead of an increase of blood sugar, an actual decrease, thus pointing to the liver as the source of the increased sugar, and when hemorrhage produces hyperglycemia it does so by some effect directly or indirectly upon hepatic activity. Rose (2) and also Andersson (3) made studies of the hyperglycemia of hemorrhage but did not make any essential contribution to the theory of the mechanism of its production. Nishi (4), in 1909, eliminated the function of the adrenal glands as necessary factors since he found that hyperglycemia was still produced in adrenalectomized animals following hemorrhage. Scott (5) accepted these results though admitting that emotional states may under certain conditions be a factor.

The work up to the present, so far as I am aware, does not provide a satisfactory explanation of the cause of the outpouring of sugar after hemorrhage. There might be considered emotion, changes in proportion of plasma to cells, which in itself should give an apparent rather than a real hyperglycemia, and lastly specific blood changes owing to replacement of a certain volume of blood by tissue lymph or to lack of blood volume.

In attempting to verify the generally accepted statement that hemorrhage is causative of hyperglycemia I obtained a series

of results which at first appeared inconsistent. In a series of about twenty experiments, only about half resulted in an increase in blood sugar and also in plasma sugar. The amount of hemorrhage was of about the same order of magnitude, or so nearly so that no consistent relationship appeared evident between body weight, amount of blood loss, and production of increase in sugar. In other words, the occurrence of hyperglycemia did not appear to be dependent solely upon overreaching a given volume of blood loss per body weight, but upon some controlling factor being more affected in some instances than in others. Thus it might be that the quantity of blood loss was near the limiting threshold of tolerance, such that only in a portion of the whole series of animals did there occur hyperglycemia. The rest of the series might logically be expected to have developed hyperglycemia with a larger blood loss.

Having in mind the facts recently emphasized by Murlin and Sweet (6) and by McDanell and Underhill (7) that an increase in acids was productive of a greater susceptibility toward the production of hyperglycemia and that injections of alkalis retard or prevent the development of hyperglycemia by ether, epinephrine, and other agents, it was thought that a change in the acid-base equilibrium in the body, indicated by that in the blood, may be the immediate determining factor.

The work of this paper is the report of an effort to gain further insight into some of the factors involved in the control of sugar mobilization after hemorrhage with contributory evidence regarding a chemical controlling mechanism of sugar balance.

Methods.

Blood and Plasma Sugar.

Rabbits alone were used in this series of experiments. Most of the previous study of the effects of hemorrhage on blood sugar by earlier investigators have been made on rabbits. They do not as a rule give much or any evidence of excitement on handling, are easily bled from the ear vein without any anesthetic and without struggling, and are well supplied with hepatic glycogen. Blood was drawn from the ear by cutting into but not through the marginal ear vein. The blood was collected in small wide-mouthed bottles or centrifuge tubes containing enough potassium oxalate to prevent clotting. The subsequent hemorrhages for the purpose of

studying the effects of the loss of blood were made after a period of 1 hour, more or less, as specified in the tables.

Anesthetics were purposely avoided even at the expense of increased difficulty of withdrawing of blood. The use of an anesthetic adds complications since it is impossible to standardize anesthesia and its effects on the blood contents and on activity of body cells. Different animals respond somewhat differently to ether even though care is especially taken in regard to intensity of anesthesia and its duration. This has been often observed in study of hyperglycemia following ether anesthesia. While hyperglycemia always follows, its grade varies considerably in comparing different animals. Consequently the additional variable incurred by anesthetics was purposely avoided.

For blood sugar determinations, the method of Lewis and Benedict (8), as modified by Myers and Bailey (9), was used. The Shreiner colorimeter was used for color comparison. This instrument was found to be very satisfactory for this purpose especially after placing tubes of black paper in the inner tubes to prevent the halo of paler color coming in through the sides.

Recent investigations (10) have shown some difficulty in the use of the method of Benedict for absolute quantitative estimations of reducing substances since the amount of color produced does not appear to be strictly proportional to sugar present, requiring corrections for wide limits. Yet on the use of the method for relative rather than absolute values the method appears to be entirely adequate and possesses the great advantage of simplicity and quickness when comparative values are to be utilized.

For plasma sugar determination, the blood was centrifuged as quickly as possible after hemorrhage to avoid glycolysis. Proportions of cells to plasma were determined by use of graduated centrifuge tubes, stoppered and centrifuged a fixed length of time, or until a constant volume of cells was obtained. This reading, while not so accurate perhaps as the hematocrit or specific gravity measurements, was deemed sufficiently accurate for the purposes at hand.

In the consideration of blood sugar it is recognized that blood contains reducing substances other than sugar, but fermentation tests have demonstrated that most of the reducing substance is sugar, and while other substances may be appreciable, perhaps of more importance than has been generally recognized, the inexactness in names of substances measured does not at all invalidate the fundamental arguments of this paper.

Alkaline Reserve Capacity.

The alkali-acid status of the blood was assayed by determinations of the alkaline reserve capacity of whole blood rather than CO₂ content of whole blood, or of plasma, or the CO₂-binding capacity of plasma alone. It is to be realized that venous blood is *more* or *less* venous according to the local conditions at the moment, and that therefore venosity of venous blood is itself a variable. This would appear also a considerable item

when blood is drawn for clinical purposes from the basilic vein after the application of a constrictor to distend the vein. Consequently it would seem desirable to reduce the condition of drawn blood to a standard. This was on tentative theoretical grounds approximated by rendering venous blood arterial by allowing it to come to a state of equilibrium with alveolar air which essentially renders the venous blood arterial and furthermore to a standard degree of arterialization.

The alkaline reserve CO_2 apparatus of Van Slyke (11) was used, though the technique has been somewhat adapted. Instead of using 5 per cent sulfuric acid, a 20 per cent solution of tartaric acid was used as recommended by Henderson and Morriss (12) for their special method. This acid does not seriously precipitate proteins as does sulfuric acid and consequently the extractor is very easily cleaned after each extraction by first running in 2 or 3 cc. of 10 per cent sodium hydroxide solution for the absorption of the carbon dioxide extracted from the acid-blood mixture. Then by the use of boiled distilled water the whole apparatus is readily cleaned by two or three washings. Any emulsified mercury is run out of the apparatus to be washed and dried by cotton and filter paper.

Again, owing to the fact as explained by Van Slyke that carbon dioxide is not completely extracted by fifteen successive shakings but should be corrected for unextracted carbon dioxide or by reextraction, I have adopted the procedure of allowing the mercury and acid-blood mixture to fall to the middle or lower third of the lower side reservoir after thorough mixing in the larger upper reservoir as Van Slyke directed, then raising the side reservoir to allow the fluid to reach just the upper aperture of the lower gas-cock. This now is turned allowing mercury to rise to bring the extracted gas to atmospheric pressure. Reading is now made, then the process is repeated twice after which the readings are usually constant for any given specimen.

In this paper corrections as recommended by Van Slyke are not given, since it is not absolute amounts of gas at standard conditions of saturation (temperature and atmospheric pressure) but it is *variations* in these amounts that under the same conditions indicate sufficiently for our purpose physiological variations. Furthermore normal differences in reserve capacity of different animals appear to be between considerable limits, especially in

herbivorous animals like the rabbit, while smaller but real variations are observed in the dog and in man. This relative measure obviously would not be satisfactory in a precise determination of critical points such as the lower limiting threshold of capacity from which an animal may or may not recover.

Effect of Hemorrhage on Hyperglycemia Production.

In performing a series of hemorrhages in rabbits to determine the constancy of production of hyperglycemia after a blood loss of a fairly constant proportion of total blood volume, there

TABLE I.
Blood Sugar before and after Hemorrhage. Control Experiments.

Rabbit No.	Weight.	Sex.	Blood sugar per cc.				Cells in whole blood.		Hemorrhage per kilo.	Total hemorrhage.
			Whole blood.		Plasma.		Before.	After.		
			Before.	After.	Before.	After.				
	kg.		mg.	mg.	mg.	mg.	per cent	per cent	cc.	cc.
27	1.6		1.18	1.02	1.59	1.26	31.0	27.0	18.7	30
28	1.4		1.17	1.26	1.51	1.68	34.0	23.0	21.4	30
29	1.2		1.23	1.59	1.51	1.68	31.6	21.3	25.0	30
31	1.43	♂	1.06	1.00	1.45	1.27	43.0	35.0	15.4	22
32	1.98	♀	1.22	1.29	1.38	1.51	28.0	27.0	10.1	20
33	1.1	♀	1.07	1.46	1.27	1.46	36.0	29.0	18.1	20
34	1.5		1.33	1.37	1.46	1.37	27.0	21.0	16.6	25
35	1.9	♀	1.29	1.29	1.51	1.37	37.0	31.5	13.1	25
36	1.3	♂	1.13	1.41	1.26	1.41	35.0	29.0	11.5	15
37	1.2		1.04	1.03	1.17	1.03	34.0	28.0	16.6	20
38	1.2	♀	1.37	1.61	1.61	1.80	37.5	27.0	16.6	20
40	1.48	♀	1.22	1.22	1.96	1.33	37.5	30.0	12.1	18
41	1.5	♂	1.29	1.46	1.35	1.56	30.7	28.7	13.3	20
42	1.7	♀	1.14	1.14	1.13	1.15	32.5	27.5	12.9	22
43	3.0	♀	1.08	1.02	1.17	1.14	38.0	34.5	7.0	22

appeared great irregularity of its production. As seen in Table I, approximately half the experiments developed a rise in blood sugar concentration of a significant amount while the remainder of the series suffered no demonstrable change in sugar content. This fact leads to the conclusion that it is not the mere loss of a given volume of blood *per se* but upon some other factor affected

TABLE II.
Blood Sugar and Alkaline Reserve Capacity of Whole Blood in Hemorrhage.

Animal No.	Sex.	Weight. kg.	Time.	Hemorrhage.*		Reserve capacity.	Notes.	
				cc.	mg.			
1919								
114B40	♀	2.4	Nov. 3,	2.00 p.m.	5.0	1.08	0.59	
				3.00 "	5.0	1.08	0.63	
				4.00 "	30.0	1.37	0.62	
				4.45 "	5.0	1.29	0.56	
115B40	♀	1.9	" 4,	2.00 "	5.0	1.22	0.67	
				2.45 "	5.0	1.26	0.70	
				3.30 "	26.0	1.67	0.66	
				4.15 "	5.0	2.38	0.63	
116B40	♂	3.1	" 6,	2.20 "	5.0	1.13	0.66	
				3.00 "	5.0	1.37	0.66	
				3.45 "	30.0	1.46	0.66	
				4.30 "	5.0	1.67	0.66	
				5.15 "	30.0	1.41	0.66	
				5.45 "	5.0	1.37	0.64	
117B40	♀	2.7	" 7,	2.00 "	5.0	1.73	0.63	
				2.50 "	5.0	1.61	0.65	
				3.45 "	30.0	1.56	0.66	
				4.30 "	5.0	1.73	0.65	
				5.15 "	30.0	2.16	0.60	
				5.45 "	5.0	2.82	0.54	
58B40	♀	1.8	Aug. 13,	3.15 "	4.0	1.55	0.77	
				4.00 "	4.0	1.46	0.73	
				5.00 "	18.0	1.50	0.71	
			" 14,	6.00 "	4.0	1.67	0.55	
				3.00 "	4.0	1.37	0.68	
				" 15,	9.30 a.m.	4.0	1.46	0.65
					11.00 "	18.5	1.41	0.64
				2.00 p.m.	4.0	1.74	0.68	
				3.00 "	14.0	2.05	0.62	
				4.30 "	4.0	1.81	0.64	
5.30 "	14.0	3.01	0.42					

* In Tables II, IV, and VI when the hemorrhage exceeded 5 cc. in any instance the last 5 cc. drawn were used for analysis.

TABLE II—*Concluded.*

Animal No.	Sex.	Weight. <i>kg.</i>	Time.		Hemorrhage.	Blood sugar per	Reserve capac-	Notes.
					<i>cc.</i>	<i>cc.</i> of blood.	ity.	
88B40	♀	1.5	<i>1919</i>					Fasting 24 hrs. before and throughout the experiment.
			Aug. 24,	4.00 p.m.	4.0	1.16	0.63	
				5.00 "	29.0	1.41	0.60	
				6.00 "	4.0	1.67	0.57	
				7.00 "	11.0	2.38	0.52	
	" 25,	11.00 "	4.0	1.56	0.66			
64B40	♀	1.7	" 21,	2.30 "	4.0	1.33	0.56	
				5.30 "	27.0	2.05	0.44	
			" 22,	2.30 "	4.0	1.29	0.72	
				3.30 "	4.0	1.37	0.68	
				4.30 "	16.0	1.67	0.60	
				6.00 "	14.0	3.01	0.46	
	" 23,	9.00 a.m.	5.0	1.37	0.63			
61B40	♀	1.4	Aug. 18,	2.00 p.m.	4.0	1.19	0.63	
				3.00 "	4.0	1.29	0.61	
				4.00 "	25.0	1.41	0.64	
				5.00 "	4.0	1.88	0.63	
				6.00 "	19.0	2.51	0.50	
			" 19,	2.15 "	4.0	1.14	0.68	

in some instances by the loss of blood. Extending the hemorrhage to a sufficient amount invariably gives rise to a marked hyperglycemia (Table II). A surprising feature, in a number of the experiments, is the early appearance of hyperglycemia, many times being quite marked at the termination of a hemorrhage as determined by the analysis of specimens of blood obtained at the termination of the hemorrhage lasting from 10 to 15 minutes. This has also been observed by Andersson (3). In this connection it may be stated that such early appearances of hyperglycemia did not appear to be dependent upon emotional states, at least as far as these are manifested by outward signs.

Because of the view of Murlin and Underhill that the acid-base balance in the blood, and in turn in the body cells, particularly in the liver, determines the mobilization of dextrose from its storage reservoirs of glycogen, it was anticipated that a hemorrhage sufficient to produce hyperglycemia might produce changes in the acid-base balance of demonstrable grade. Consequently, studies were made simultaneously of blood sugar and of alkaline reserve capacity of whole blood. From Table II it is seen that this is the case. Those experiments in which a rise in sugar appeared were usually those in which there occurred a fall in alkaline reserve capacity of whole blood. The fall in reserve capacity, furthermore, usually appeared as soon as there appeared a rise in sugar. Those instances in which no rise of sugar appeared usually did not present a fall in reserve capacity.

Furthermore, after 12 to 24 hours, whether the animals had or had not been kept from food before and during the experiment, the sugar content fell to normal while the reserve capacity rose to and sometimes exceeded normal for that animal. The two values appeared to bear a reciprocal relationship. Fasting to a moderate extent (with access to water) from 24 to 48 hours did not prevent a return to normal values for both sugar and reserve capacity. This is taken to mean that a compensation had taken place within the body cells perhaps by hepatic action in ammonia formation from protein metabolism. This could liberate an equivalent amount of sodium bicarbonate and restore the neutrality balance.

Although no quantitative study was made of the respiratory volume, I could in no case foretell the onset or occurrence of hyperglycemia by excitement or struggling, or hyperpnea in certain of the animals in which this occurred. In other words, hyperpnea or struggling, such as occurred in our tame, frequently handled rabbits, was not necessarily concomitant with either a demonstrable fall in reserve or rise in sugar. The conclusion is not made, however, that sufficiently prolonged excitement and hyperpnea might not of itself have produced parallel blood changes. Such a problem concerns this thesis only to the extent of not being the causative factor within these series of experiments.

Effect of Alimentary Administration of Alkalies and Acids.

So far in this investigation there appears a reciprocal relationship between the rise in blood (or plasma) sugar and the fall in alkaline reserve capacity of whole blood after hemorrhage. Which of these two factors is causative and which resultant is not directly answerable from the preceding experiments. This question is approached experimentally from two directions; first, by considering that the fall in reserve capacity of blood reflects the acid-base balance in body cells and hence represents the cause of the hyperglycemia, namely cellular acidosis, second, by considering

TABLE III.

Effect on Blood Sugar of Administration of 0.6 Gm. of NaHCO₃ by Stomach 2 to 3 Hrs. before Hemorrhage.

Rabbit No.	Weight.	Sex.	Blood sugar per cc. of blood.				Cells in whole blood.		Hemorrhage per kilo.	Total hemorrhage.
			Whole blood.		Plasma.		Before.	After.		
			Before.	After.	Before.	After.				
			kg.	mg.	mg.	mg.	mg.	per cent		
46	1.3	♂	1.19	1.20	1.10	1.16	27.0	21.0	15.3	20
47	1.98	♀	1.26	1.33	1.46	1.41	33.3	28.2	10.1	20
48	1.98	♂	1.33	1.26	1.46	1.40	41.0	35.3	10.1	20
54	1.32	♀	1.26	1.26	1.37	1.39	35.5	30.0	15.1	20

hyperglycemia after hemorrhage to cause the fall in alkaline reserve capacity of whole blood by virtue of incomplete oxidation of metabolites.

On the basis of a fall in reserve by any internal mechanism acting as the causative factor it was thought that by increasing the potential alkali in the body animals should be less subject to hyperglycemia after hemorrhage than normal controls. Hence capsules of sodium bicarbonate were given by mouth and later the animals subjected to hemorrhage of the same order of magnitude as in the preceding series. As seen from Tables III and IV hyperglycemia was, indeed, retarded in appearance. Quite by accident, following overenthusiasm over this means of medica-

tion, it was found that large quantities of bicarbonate actually facilitate the appearance of hyperglycemia on hemorrhage. This, however, appears readily explicable on the basis of Moore's work (13), in which he observes a circulatory injury by excessive tissue alkalosis which in this instance could readily explain the rise in sugar values by hepatic congestion, particularly in conjunction with a reduction in "basal blood flow" from hemorrhage as proposed by Gesell (14).

TABLE IV.

Blood Sugar and Alkaline Reserve Capacity of Whole Blood after Alkali Administration.

Animal No.	Weight.	Sex.	Time.	Hemorrhage.	Blood sugar per cc. of blood.		Reserve capacity.	NaHCO ₃
					cc.	mg.		
	<i>kg.</i>		<i>1919</i>					
101B40	2.6	♀	Oct. 17, 2.45 p.m.					2.1
			4.45 "	5	1.26	0.78		
			5.30 "	5	1.33	0.85		
			6.00 "	45	1.33	0.77		
109B40	1.9	♀	" 27, 9.10 a.m.					2.1
			10.10 "	5	1.29	0.93		
			11.00 "					0.7
			11.05 "	5	1.45	0.76		
			11.45 "	29	2.51	0.72		
112B40	2.1	♀	" 28, 8.30 "					0.7
			9.10 "	5	1.13	0.69		
			10.20 "	5	1.03			
			10.45 "	30	1.05	0.74		

If the basis just proposed is logical, then a diminution of body reserve in alkali by administration of acids should render the animals more subject to hyperglycemia by hemorrhage. This line of attack requires careful control since no one doubts that acids do produce of themselves hyperglycemia when given in sufficient quantity. Consequently hemorrhage was attempted after preliminary examinations had demonstrated that sugar and reserve values were approaching normal. This eliminates the

danger of development of further hyperglycemia from absorption of acid rather than from hemorrhage itself. Tables V and VI illustrate the effects of hemorrhage after acid (KH_2PO_4) administration by mouth.

While both alkali and acid administration are coupled with danger of complicating factors, it is given as contributory evidence on this thesis.

TABLE V.

Effect on Blood Sugar of Administration of 0.6 Gm. of KH_2PO_4 2 Hrs. previous to First Hemorrhage.

Rabbit No.	Weight.	Sex.	Blood sugar per cc. of blood.				Cells in whole blood.		Hemorrhage per kilo.	Total hemorrhage.
			Whole blood.		Plasma.		Before.	After.		
			Before.	After.	Before.	After.				
	<i>kg.</i>		<i>mg.</i>	<i>mg.</i>	<i>mg.</i>	<i>mg.</i>	<i>per cent</i>	<i>per cent</i>	<i>cc.</i>	<i>cc.</i>
49	1.9	♀	1.46	1.61	1.74	1.88	37.0	32.6	10.5	20
50	2.6	♀	1.46	1.61	1.59	1.74	32.3	30.6	7.6	20
51a*	2.6	♀	1.19	1.20	1.37	1.39	41.5	38.0	7.6	20
51b	2.6	♀	1.46	1.50	1.50	1.65	31.0	21.0	7.6	20
53	2.2	♀	1.46	1.56	1.56	1.74	33.5	30.0	9.0	20
S4a†	2.8	♀	0.98	0.94					1.0	3
S4b	2.8	♀	1.05	1.05					1.0	3

* Large fat rabbit with full stomach. This animal was kept from food for 18 hrs., when the experiment was repeated as No. 51b.

† In order to answer a possible objection to this series, that the increase in blood sugar after hemorrhage may be due to the continued absorption or activity of the acid rather than to the effects of hemorrhage, Rabbit S4a was fed the 0.6 gm. of KH_2PO_4 as in the rest of the series, but differing from these in that a minimum amount of blood was withdrawn. The test was repeated after 24 hrs. fasting, similar to No. 51b. The blood sugar did not rise at either time, eliminating, at least as far as one experiment may be considered as control, the direct effects of acid alone as a possible cause of the increased sugar.

TABLE VI.

Effect on Blood Sugar and Alkaline Reserve Capacity of Whole Blood of Acid Administration.

Animal No.	Weight.		Sex.	Time.	Hemorrhage.	Blood sugar per cc. of blood.		Alkaline reserve capacity.	KH ₂ PO ₄	Notes.
	kg.	gms.				cc.	mg.			
103B40	2.1	♂	1919						0.8	Struggled.
			Oct. 20,	9.30 a.m.	5					
				10.30 "	5	1.03	0.60			
				11.30 "	5	1.08	0.45			
				1.45 p.m.	5	0.98	0.63			
	2.40 "	30	1.25	0.56						
107B40	2.1	♀	"	23,	8.30 a.m.	5	1.03	0.54	0.8	
					10.00 "	5	1.00	0.60		
					10.30 "	28	1.13	0.59		
					10.50 "	5	1.05	0.55		
					11.30 "	5	1.05	0.55		
113B40	2.1	♀	"	28,	3.10 p.m.				0.8	
					4.00 "	5	1.46	0.62		
					4.45 "	5	1.46	0.59		
					5.30 "	29	1.74	0.58		

Effects of Dextrose Injections.

Taking up the problem from the point of view that the hyperglycemia is causative and the fall in reserve capacity is resultant, we performed some experiments by observing the values of blood sugar and alkaline reserve after dextrose injections. As seen from Table VII, the blood sugar was increased but with no detectable change in reserve capacity. It is not, however, inferred that by using prolonged injections and in greater quantities that an acidosis in the newer sense may not be produced (15), yet it does not seem probable from these results that the sugar increase in this investigation is the cause but is rather the result of changes of cellular reaction.

TABLE VII.

Effect on Blood Sugar and Alkaline Reserve Capacity of Whole Blood of Dextrose Injections.

Animal No.	Weight.	Sex.	Time.	Hemor- rhage.	Blood sugar per cc. of blood.	Alka- line reserve.	20 per cent dextrose injected in- travenously.	
	<i>kg.</i>		<i>1919</i>	<i>cc.</i>	<i>mg.</i>		<i>cc.</i>	
92B40	2.4	♀	Oct. 7, 10.30 a.m.	5	1.35	0.70	5	
					5	1.46		0.65
					5	1.54		0.65
					5	1.96		0.65
					5	1.54		0.62
94B40	2.5	♀	" 8, 1.20 "	5	1.46	0.68	5	
					5	1.37		0.64
					5	1.76		0.68
					5	1.37		0.54
96B40	2.0	♀	" 9, 2.00 "	5	1.33	0.70	6	
					5	1.33		0.67
					5	2.05		0.65
					5	1.37		0.63

DISCUSSION.

The results of the experiments described appear to indicate that hemorrhage produces a rise in blood sugar by changes in the state of acid-base balance in body cells, which state is fairly well reflected in corresponding changes in the general circulation. The chief seat of action is probably the liver, for this is the location of glycogen storage most readily affected. Furthermore, the observations of Schenck have shown that ligation of liver vessels prevents hyperglycemia from hemorrhage. The observations of Gesell that hemorrhage lowers alkaline reserve capacity of plasma led him to conclude this was responsible for tissue asphyxia by the diminished "basal blood flow." This tissue asphyxia is effective presumably chiefly in the liver, and hence may be restated by speaking of local changes in acid-base balance in favor of intracellular acidity, a condition generally

thought adequate to facilitate glycogenolysis. A change in hepatic blood might be far more instructively studied since it is conceivable that local changes might be masked to a considerable extent by mixing with systemic blood. Direct study of portal or hepatic artery blood *versus* hepatic vein blood does not at present appear feasible since such an investigation would necessitate extensive abdominal trauma together with anesthesia both of which factors involve serious contraindications towards direct observation.

From the observations (1) that a rise in blood sugar (also plasma sugar) occurs simultaneously with a fall in alkaline reserve capacity of whole blood, (2) that alkalis administered by mouth, which enrich the portal vein blood in alkali, retard the onset of hyperglycemia, while (3) acids by the same route increase the susceptibility to hyperglycemia on hemorrhage, and further (4) that artificial enrichment of blood in sugar by injection in small quantities does not immediately produce a fall in reserve, the conclusion seems warranted that hemorrhage produces hepatic asphyxia in such a way that acids accumulate in liver cells and there promote glycogenolysis. These conditions then lay the responsibility of the rise in sugar upon the fall in alkali in cells. This fall in alkali in cells is fairly well reflected in the state of the blood in the general circulation since all tissues are more or less subjected to the same diminution of basal blood flow, yet local hepatic changes may not necessarily be quantitatively determined by systemic blood study owing to the factor of mixture of hepatic vein blood with systemic blood. The increase in sugar would not appear to be due to concentration of sugar in the blood owing to passage of water from the circulation as emphasized by Epstein (16) in certain conditions since the proportion of plasma to whole blood or to corpuscles may be found much increased $\frac{1}{2}$ to 1 hour after hemorrhage, while both the whole blood and the plasma contain an increased quantity of sugar.

The author believes that the evidences presented support the contentions of Murlin and of Underhill and their collaborators that the acid-base balance in the blood and ultimately that in the body cells, particularly the liver, is one important factor determining the state of glycogenolysis as well as glycogenesis, and that further the hyperglycemia of hemorrhage can be ration-

ally explained not by invoking obscure factors such as shock, depletion, anemia, or emotional states, but on the basis of a disturbance in normal neutrality.

SUMMARY.

1. Whole arterialized blood was used in a study of alkaline reserve capacity.

2. Hemorrhage produces, if its grade is properly chosen, a reciprocal change in both a fall in the alkaline reserve capacity of whole blood and rise in blood and plasma sugar concentration.

3. Hyperglycemia and fall in reserve capacity of whole blood frequently appear within a few minutes after hemorrhage.

4. Recovery from both the reduction in alkaline reserve capacity of whole blood and the hyperglycemia occurs promptly within a relatively few hours even in the limited fasting animal.

5. Hemorrhage produces hyperglycemia more readily when the total bodily alkaline reserve is diminished by administration of acid and less readily when proper amounts of alkali are given.

6. One effective cause of sugar changes in the blood appears to be a disturbance in the acid-base balance in tissue cells indicated by that of the circulating blood in general.

BIBLIOGRAPHY.

1. Schenk, F., *Arch. ges. Physiol.*, 1894, lvii, 553.
2. Rose, U., *Arch. exp. Path. u. Pharmakol.*, 1903, 1, 15.
3. Andersson, N., *Biochem. Z.*, 1908, xii, 1.
4. Nishi, M., *Arch. exp. Path. u. Pharmakol.*, 1909, lxi, 186.
5. Scott, E. L., *Am. J. Physiol.*, 1914, xxxiv, 271.
6. Murlin, J. R., and Sweet, J. E., *J. Biol. Chem.*, 1916-17, xxviii, 261.
7. McDanell, L., and Underhill, F. P., *J. Biol. Chem.*, 1917, xxix, 227.
8. Lewis, R. C., and Benedict, S. R., *J. Biol. Chem.*, 1915, xx, 61.
9. Myers, V. C., and Bailey, C. V., *J. Biol. Chem.*, 1916, xxiv, 147.
10. Addis, T., and Shevsky, A. E., *J. Biol. Chem.*, 1918, xxxv, 43.
11. Van Slyke, D. D., *J. Biol. Chem.*, 1917, xxx, 347.
12. Henderson, Y., and Morriss, W. H., *J. Biol. Chem.*, 1917, xxxi, 217.
13. Moore, B., *J. Physiol.*, 1919, liii, p. xxxvi.
14. Gesell, R., *Am. J. Physiol.*, 1918-19, xlvi, 468.
15. Macleod, J. J. R., and Fulk, M. E., *Am. J. Physiol.*, 1916, xlii, 193.
16. Epstein, A. A., *Proc. Soc. Exp. Biol. and Med.*, 1916, xiii, 67.

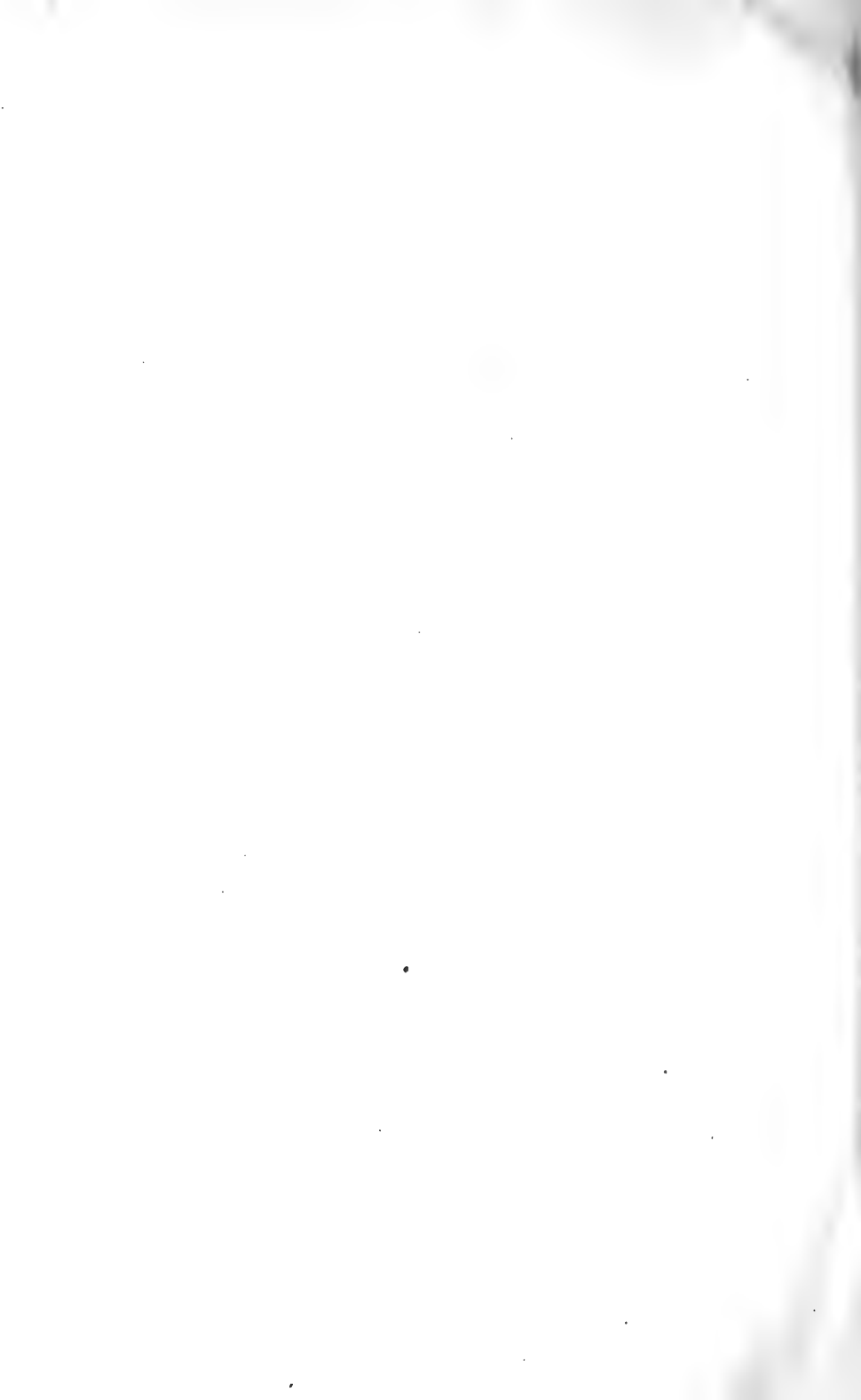

HEMOGLOBIN.

I. OPTICAL CONSTANTS.

BY WILLIAM H. WELKER AND CHARLES SPENCER WILLIAMSON.

(From the Departments of Medicine, and Physiology and Physiological Chemistry, College of Medicine, University of Illinois, Chicago.)

(Received for publication, December 1, 1919.)

INTRODUCTION.

In 1873, Vierordt (1) announced the definite relation of the concentration of colored solutions to the extinction coefficients of the same, in the spectrophotometer. He expressed the relation in the formula $A = \frac{c}{a}$ in which A represents the absorption constant for the substance, c , the concentration in gm. per cc., and a , the extinction coefficient. (By later writers, E is used to indicate the extinction coefficient.)

The extinction coefficient is the reciprocal of the thickness of solutions required to reduce light of unit intensity to that of 0.1 unit intensity. This epoch-making work of Vierordt made possible a new line of investigation in connection with substances forming colored solutions. Among various substances studied was hemoglobin. Von Noorden (2), Otto (3), Lambing (4), Hufner (5), de Saint-Martin (6), Bardachzi (7), Aron and Müller (8), Butterfield (9), and Letsche (10) made a study of hemoglobin and compared the hemoglobin from some of the different species. The results that these investigators obtained did not vary sufficiently to show that the hemoglobins differed markedly in so far as their absorption coefficients were concerned. The work of Korniloff (11), Sczelkow (12), Krüger (13), and Velichi (14) seemed to indicate that the hemoglobins were not all the same since they obtained different extinction coefficients for some of them. Sczelkow explained the differences obtained by him on the basis of differences in concentration of the hemoglobin solutions he employed.

The work of Reichert and Brown (15) gave evidence that crystal forms of the hemoglobins from various species were so different that it was possible to identify species by them. Marshall and Welker (16) discovered an improvement in the method for the preparation of hemoglobin crystals. As prepared by the older methods, the solutions of hemoglobin always contain small amounts of other colloids. These colloids were removed by treatment with aluminium hydroxide cream. This treatment yielded hemoglobin solutions in the case of nearly all species which would crystallize readily. With the difference in crystal form in mind and with a fairly easy method for obtaining crystallized hemoglobin available, the study of the absorption coefficients of the hemoglobin of various species was undertaken.

EXPERIMENTAL.

Blood was drawn into a flask and defibrinated by shaking with glass beads. The defibrinated blood was strained through cheese-cloth and then centrifugalized until the corpuscles were fairly well sedimented. The corpuscles were washed with isotonic sodium chloride solution three or four times, thus removing the major portion of the serum protein. The washed corpuscles were laked by means of ether. This was added, a few drops at a time, and the liquid agitated to insure thorough mixing, and the process continued until a clear solution was obtained. If the solution was so concentrated as to be viscid, it was diluted with water and then treated with an approximately equal volume of aluminium cream. The cream was thoroughly mixed with the solution, and the mixture was then placed on a filter. The solutions of hemoglobin thus prepared were quite clear. They were cooled to a temperature of about 0°C ., and treated with absolute alcohol which had also been cooled to about 0°C . until the percentage of alcohol amounted to from 20 to 30 per cent. The percentage of alcohol required depended upon the concentration of the hemoglobin solution, and also upon the solubility of the particular hemoglobin. Solutions of hemoglobin thus treated with alcohol were allowed to stand at a temperature of a few degrees below 0°C . until crystallization was complete. The crystals were then loosened from the

sides of the flask containing the solution, by agitation of the liquid. The crystals were washed by means of 25 per cent alcohol at 0°C. by decantation or by centrifugalization in a cup (17) specially built for this purpose. It is necessary that this low temperature be maintained while the hemoglobin is being washed with the diluted alcohol. If the temperature rises appreciably above 0° the hemoglobin is changed from a crystalline substance over into an amorphous substance. Some of the crystals were roughly dried by placing them on absorbent paper, and transferred to a weighing bottle of known weight. A sample of the moist hemoglobin was weighed out, dissolved in a small quantity of 0.1 per cent sodium carbonate solution, transferred quantitatively to a standard 10 cc. volumetric flask, and diluted to the mark with distilled water. After thorough mixing, a trial dilution of this fluid was made in such a way as to make the total dilution such that, when placed in the spectrophotometer, the readings would be somewhere between 70 and 80, that is, in that portion of the curve where, according to experience, the readings were most accurate. After determining approximately what the dilution should be to bring the reading at that portion of the curve indicated, an accurate dilution was made and this placed in the spectrophotometer and the readings were taken. The figures given for the optical constants represent the mean of ten readings in each position from at least two separate and closely agreeing dilutions. At least two separate crystallizations were made from each separate species of blood, using a different animal for each crystallization.

In this investigation we used the Hufner apparatus in which the thickness of layer of solution remains constant, and E is determined by measuring intensity of the remaining light. This is accomplished by means of an analyzing Nicol prism. It has been shown that the extinction coefficient E is equal to $-2 \log \cos \theta$ where θ is the angle of rotation just referred to. In order to obtain E , the angle of rotation θ necessary to produce equality in the upper and lower field is measured and E can then be computed. Bürker has computed a curve of coefficient E for angle of rotation from 60 to 80 degrees. Having determined the angle of rotation the values of E can be read directly from this curve. The curve used in this investigation appears

to be derived from the two published previously by Bürker (18). The experimental methods used in connection with the spectrophotometric work are fully described by Williamson (19) in a previous paper.

The balance of the hemoglobin in the weighing bottle was dried to constant weight over sulfuric acid. From the figures obtained for the moisture content of this sample, the dried weight of the sample used in the spectrophotometer was calculated. After we had determined the concentration of solution and the extinction coefficient, it was a simple matter to arrive at the

TABLE I.
Absorption Coefficients.

Animal.	A'_0	A_0
Dog.....	0.001191	0.001878
Ox.....	0.001187	0.001909
Cat.....	0.001137	0.001778
Chicken.....	0.001277	0.002002
Guinea pig.....	0.001180	0.001895
Rat.....	0.001130	0.001777
Sheep.....	0.001224	0.001934
Horse.....	0.001164	0.001846
Pig.....	0.001253	0.001988
Human.....	0.001179	0.001851

value of the absorption coefficient. Determinations were made on the hemoglobins of the dog, ox, cat, chicken, guinea pig, rat, sheep, horse, pig, and man. The results are shown in Table I.

DISCUSSION.

The figures obtained vary somewhat from those obtained by other investigators. The experimental conditions of this investigation were not precisely the same as those used by the former investigators. Our readings were made in spectral region 534.0 to 542.0 while those of Hüfner were made in the region 531.5 to 542.5 and those of Butterfield in the region 533.5 to 542.0. There were other slight differences in the conditions. Butterfield (9) has pointed out that minor differences in these conditions change the results appreciably. This may possibly explain the differences in results.

CONCLUSIONS.

From the results obtained in this experiment, it would appear that there is not sufficient difference in the absorption coefficients of the hemoglobin of various species to serve as a means of identification of the species. This finding confirms the conclusions of most of the previous investigators.

BIBLIOGRAPHY.

1. Vierordt, K., *Die Anwendung des Spectralapparates zur Photometrie der Absorptionsspectren und zur quantitativen chemischen Analyse*, Tübingen, 1873, 28.
2. von Noorden, C., *Z. physiol. Chem.*, 1880, iv, 9.
3. Otto, J., *Z. physiol. Chem.*, 1882-83, vii, 57.
4. Lambing, *Revue biologique du Nord de la France*, 1889; quoted by de Saint-Martin.
5. Hüfner, G., *Arch. Physiol.*, 1894, 138.
6. de Saint-Martin, L. G., *Dosage de l'hémoglobine et analyse quantitative d'un mélange de deux de ses variétés au moyen du spectrophotomètre*, Paris, 1898, 87.
7. Bardachzi, F., *Z. physiol. Chem.*, 1906, xlix, 465.
8. Aron, H., and Müller, F., *Arch. Physiol.*, 1906, suppl., 109.
9. Butterfield, E. E., *Z. physiol. Chem.*, 1909, lxii, 173.
10. Letsche, E., *Z. physiol. Chem.*, 1912, lxxvi, 243.
11. Korniloff, A. A., *Z. Biol.*, 1876, xii, 515.
12. Sezelkow, *Arch. ges. Physiol.*, 1887, xli, 373.
13. Krüger, F., *Z. physiol. Chem.*, 1898, xxv, 256.
14. Velichi, J., *Deutsch med. Woch., vereins-beilage*, 1900, xxvi, 148.
15. Reichert, E. T., and Brown, A. P., *Carnegie Inst. of Washington, Publication No. 116*, 1909.
16. Marshall, J., and Welker, W. H., *J. Am. Chem. Soc.*, 1913, xxxv, 820.
17. Welker, W. H., *J. Lab. and Clin. Med.*, 1919, v, 125.
18. Bürker, K., in Tiegerstedt, R., *Handb. der physiologischen Methodik*, Leipsic, 1911, ii, pt. 1, 190, 194.
19. Williamson, C. S., *Arch. Int. Med.*, 1916, xviii, 505.

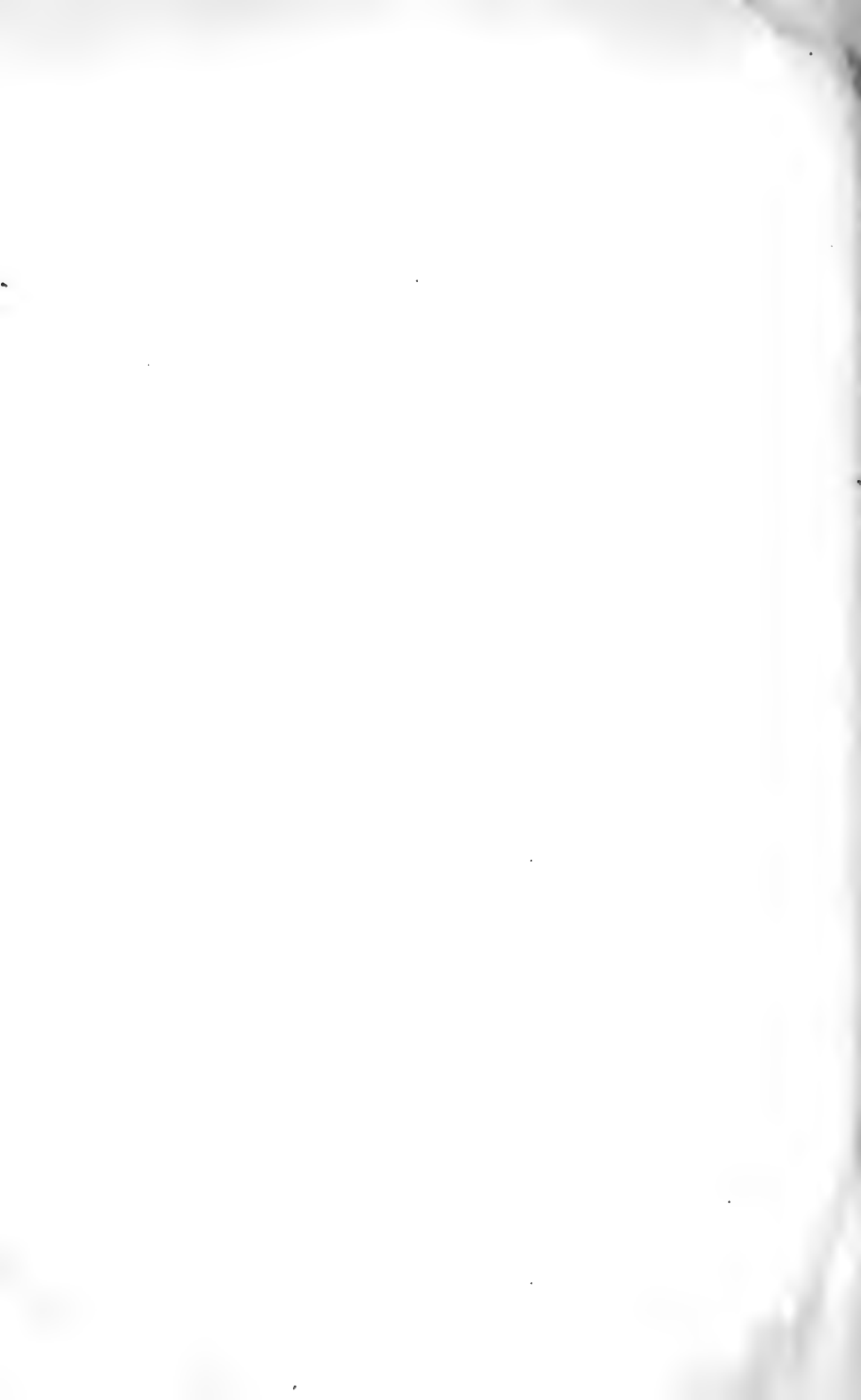

FAT-SOLUBLE VITAMINE.*

III. THE COMPARATIVE NUTRITIVE VALUE OF WHITE AND YELLOW MAIZES.

BY H. STEENBOCK AND P. W. BOUTWELL.

WITH THE COOPERATION OF E. G. GROSS AND MARIANA T. SELL.

(From the Laboratory of Agricultural Chemistry, University of Wisconsin, Madison.)

PLATE 2.

(Received for publication, November 25, 1919.)

In the preceding paper of this series (1) we emphasized the necessity of using caution when attempting to generalize in regard to the probable occurrence or non-occurrence of the fat-soluble vitamine in plant or animal tissues. In the data therein presented we indicated that tissues serving in the capacity of storage organs in the plant kingdom might nevertheless contain relatively large amounts of the fat-soluble vitamine. It was found to be an unwarranted procedure to conclude that only tissues of great activity contain large amounts of the fat-soluble vitamine as has been the tendency on the part of certain investigators in this field. In instances where no differences in biological activity were apparent nevertheless great variations in fat-soluble vitamine occurred. For instance, the carrot and the yellow sweet potato were found to contain so much of the fat-soluble vitamine that as a source of this dietary essential it was necessary to class them with leafy materials rather than with the cereal grains such as barley, wheat, oats, or even maize¹ which are acknowledged to contain relatively little of it. On the other hand, the mangel, sugar beet, red beet, parsnip, dasheen,

* Published with the permission of the Director of the Wisconsin Experiment Station.

¹ In American usage, corn is a specific term used for the designation of the grain *Zea mays*, but as in foreign English speaking countries this is not the case we have used the term maize.

rutabaga, and potato, though also admittedly storage organs, were found to be decidedly deficient in it. It was moreover emphasized that, though the conclusions in regard to the relative amounts of this vitamine occurring in the different materials that were investigated were undoubtedly correct, the values were not to be considered as absolute, as, for reasons unknown, differences in the amounts present were found to occur as indicated in the vitamine content of different samples of potatoes.

That such differences undoubtedly occurred we were impressed with, when 2 years ago we started to compare the fat-soluble vitamine content of cereal grains. From the statements prevalent in the literature at that time (2) we had received the impression that maize, as an example, was very poor in its content of this dietary constituent. We were therefore considerably surprised when in our experimental lots most of our rats on yellow maize—when this was suitably supplemented with vitamine-free protein and salts—continued to grow and ultimately reached maturity and maintained themselves in good condition with no signs of malnutrition; in fact not a single instance of xerophthalmia, which usually results secondarily from the fat-soluble vitamine deficiency, was recorded in these experimental groups. Obviously the case against maize as a fat-soluble vitamine deficient food was not so strong as the investigation of others had led us to believe.

As our data on the distribution of this dietary essential accumulated we were impressed with the fact that there appeared to be a remarkable coincidence in the occurrence of yellow plant pigments and resultant success in nutrition when all other requirements outside of the fat-soluble vitamine were known to be satisfied (3). For instance, both the carrot and sweet potato which are highly impregnated with yellow pigment were found to supplement successfully rations known to be deficient in this vitamine. Other roots not so pigmented were found impotent. Butter rich in pigment is very efficient and similarly oleo oils containing the pigment show a considerable fat-soluble vitamine content. Taking another example, we have in the case of the leafy parts of plants both the growth-promoting property and the appearance of yellow plant pigments associated, though here the yellow pigments are masked by the chlorophyll. At the present

time many such correlations have been made by us and shall later be presented in their proper connections. Suffice it to say that since these general premises have apparently justified abstract inferences in regard to the probable occurrence or absence of the fat-soluble vitamine on the color basis, it appeared probable that such correlations might be extended to that of the white and yellow maize kernels to which we shall here confine our consideration. It was recalled that at one time a fat-soluble vitamine deficiency in the ration of our stock animals was indicated and that at about this time white maize instead of yellow maize had been fed as a part of their ration. No etiological connection between the two, however, was established at this time.

In the data that follow, especially as will be seen from data graphically presented in the various charts, the surmised of the differences in comparative dietary efficiency of white and yellow maize due to fat-soluble vitamine content in correlation with the occurrence of yellow pigments was substantiated. White maize, in every case where the experimental animals were dependent on it for their fat-soluble vitamine, produced absolute nutritional failure. On the other hand, yellow maize under similar conditions gave good and, even if not in most cases, sometimes normal results.

EXPERIMENTAL.

In general, the same experimental procedure that has almost become a standard in this laboratory in the last 2 years was used in these experiments. With a few exceptions, where the ration available imposed limitations, four young rats were kept in a group and fed as such but, as noted in the graphs, sometimes data with more than four animals are recorded. In these cases the experiments were repeated and the combined data presented in one chart. No record of the amounts of the rations consumed by the animals was kept other than that indicated by the total amounts of rations consumed which made no allowance for that wasted in the cages which often totals to a considerable quantity. While accurate consumption records are much to be desired and in many instances are even indispensable for validating certain conclusions it was felt that our general conclusions would not necessitate the additional labor which the keeping of such records

would entail, especially when on such a palatable food material as maize no critical variation in amounts consumed by the animals was to be expected.

In preparation for the ration, the maize was finely ground, and mixed with casein— which had previously been made vitamine-free by very dilute acetic acid extraction—and with salts. As maize at the level fed in the experiments carries plenty of the water-soluble vitamine for growth no supplementation with this vitamine was necessary to make growth possible when all the other dietary requirements were complied with. In the main, the experiments were confined to white and yellow maize, but in addition there was investigated a red maize carrying a white endosperm, a red maize carrying a yellow endosperm, and a variegated maize of red, yellow, white, and blue effects caused by variations in the distribution of these pigments between the pericarp, the aleurone layer, and the endosperm. The specific make-up of the rations is indicated in the various charts.

Fat-Soluble Vitamine in Yellow Maize.

The yellow maizes fed were such as were well recognized as distinct varieties grown in the corn-producing sections of the United States. They were represented by Reid's yellow dent, grown extensively in the corn belt; Murdock, grown in the northern corn belt; Golden Glow, Wisconsin No. 12, grown in central and southern Wisconsin, and an early yellow dent known as Wisconsin No. 8, grown in central and north central Wisconsin.

In Chart 1 are shown the curves of growth of nineteen young rats put on the yellow corn ration soon after weaning. As seen in the chart, in general, a very satisfactory degree of growth was observed with the rats on these different varieties of maize. It is true that there obtain some variations in the growth performance of the animals, but with the limited data available these differences are not to be associated offhand with variations in vitamine content, but rather are to be attributed to variations in the natural ability of the animal to grow irrespective of the character of the ration. It is not meant to infer that differences in vitamine content may not have obtained, but rather that these were not indicated unequivocally by the experimental technique employed. In a number of instances a poor showing in growth response or ultimate failure may require special mention.

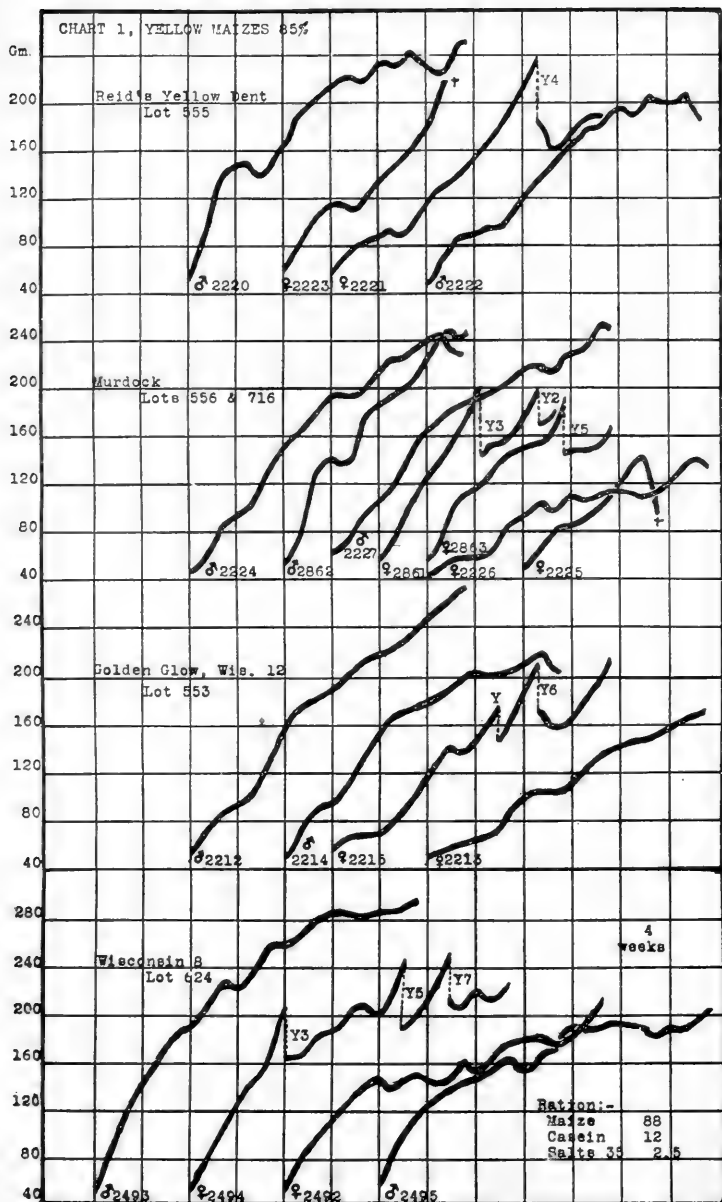

CHART 1.

In Lot 555 fed Reid's yellow dent, Rat 2223 died suddenly as a result of impaction of the stomach with large pieces of shavings gathered from the litter used in the cage. Her growth had been entirely normal. In Lots 556 and 716 fed the Murdock variety of yellow maize, Rats 2225 and 2226 gave poor results. Of these, the rapid failure of Rat 2225 is to be attributed to an infection localized in the generative organs, but the cause of the subnormal growth of Rat 2226 could not be ascertained. She appeared to be in good condition except for her weight. A similar statement can be made in regard to the case of Rat 2213 of the Golden Glow group, Lot 553. In Lot 624 fed Wisconsin No. 8, no special comments are necessary except with respect to Rat 2492 which failed to expel her fetus and necessitated our chloroforming her.

One fact which stands out dominantly is that of the nine pregnancies which occurred on yellow maize not one resulted in the production or rearing of young to the weaning stage. A statement of the individual conditions may bring this out forcibly.

In Lot 555, Rat 2221 gave birth to a litter of four young which were raised to an average weight of 20 gm. in 17 days. Though slightly undersized for their age they were in good condition until one day they were found, one dead and the others very lethargic and in apparent distress. The following day all were dead. In the Murdock group, Lot 716 produced three litters of young; of these Rat 2861 nursed one individual from her first litter to a weight of 30 gm. when it died, but none of her second litter lived longer than a few days; Rat 2863 nursed her young for 10 days when they too were found missing. On Wisconsin No. 12, Lot 553, Rat 2215 came near raising her second litter. While the first litter died on the day of birth the second litter containing six individuals was nursed for 3 weeks. Normal young in our colony average about 38 gm. at this age, but these six weighed only 111 gm. and died at the end of the 4th week. Wisconsin No. 8 supported reproduction no better in Lot 624. Here Rat 2494 lost her first two litters before they were a week old and her third when slightly over 3 weeks, though it had been reduced to four animals; yet the mother remained in excellent condition.

Offhand, this failure of reproduction is not to be associated with the fat-soluble vitamine relations, but the data here presented do not give us a basis for further comment.

In Chart 1 is indicated how, over a period of about 6 months, many rats on a ration in which yellow corn served as the sole source of fat-soluble vitamins grow at a rate which is to be considered normal. That growth can be continued over a longer period of time is shown in Chart 2. The rats of this group were fed a similar ration to those whose growth curves are shown in Chart 1 differing only in that to the 88 gm. of maize and the 12 of casein 0.75 gm. of sodium chloride, 4.43 gm. of calcium lactate, and 0.14 gm. of iron citrate were added instead of the 1.0 gm. of sodium chloride and 1.5 gm. of calcium carbonate. On this ration Rat 1707' and 1705' grew over a period of 13 months at

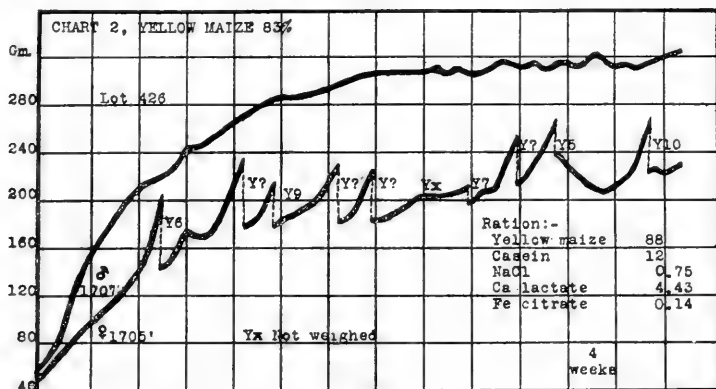

CHART 2.

rates which can be considered normal though it is probably true that the initial rapid increase of weight was not continued for so long a period as might have been expected for the average of our colony, but this may not have been entirely due to a limitation of the fat-soluble vitamins factor, as the same result has often been obtained on other supposedly good rations—including yellow maize—which we had supplemented with this vitamins. In the case of the female, no doubt her numerous pregnancies delayed her growth; yet she maintained herself in excellent condition. The male grew better, yet after the first 8 months of growth it became rather rough in appearance although there was no evidence of any cutaneous infections; its eyes remained large and bright and it continued to be sexually potent to the time

of writing. Unequivocal indications of a fat-soluble vitamine deficiency may then be said to have been totally absent.

It was noted in the discussion of the graphs in Chart 1 that absolute failure in the rearing of the young was the rule. This was duplicated in the first eight pregnancies of this female, in fact all the young were found dead shortly after birth or else were found missing before any record of their number or weight had been obtained. Our data on this are complete with one exception where by an oversight with a change in the laboratory staff the rat was not weighed or closely observed for 3 weeks, and so it is not known how long that litter lived. To provide more favorable conditions for the rearing of the young, the young of the ninth pregnancy were reduced in number to three animals shortly after birth. These were reared rapidly, averaging 36 gm. in weight at the end of 3 weeks and 45 gm. at the end of 4 weeks which is a rate of growth that can be considered normal. With the tenth litter reduced to four animals this performance was duplicated. We have therefore secured information showing that it is possible to secure the rearing of some young on a ration where yellow maize is the sole source of the fat-soluble vitamine. In instances where lactating mothers were transferred when mature from our standard stock ration to the corn ration fed in this lot, no difficulty in the rearing of young has been experienced, in fact, both the experimental Rats 1707' and 1705', whose history was just discussed, were members of a litter brought up under these conditions. It is thus indicated that, when rats make their growth on such a ration and have later the added demands of lactation imposed on them, they cannot meet the requirements of the situation as they can when they have been reared on a better ration. But it is not to be inferred that the fat-soluble vitamine is necessarily the limiting factor. Furthermore, it remains to be seen if the fact that the young of the earlier pregnancies were not reared, while those of the later were, has any special significance.

Fat-Soluble Vitamine Content of White Maizes.

When young rats at an entirely comparable period in their development to those shown in Charts 1 and 2 are put on white maize supplemented with purified proteins and salts, failure in

growth and even in maintenance of life rapidly ensues. This is shown in Chart 3. In the dissection of these data we are limited in the conclusions that we can draw by the fact that differences in growth performances can, to a certain extent—not determined—be attributed to variations in the growth impulse of the animals. To a very great degree these differences should be erased by the method we used in the selection of our animals, because in this procedure animals are selected for differ-

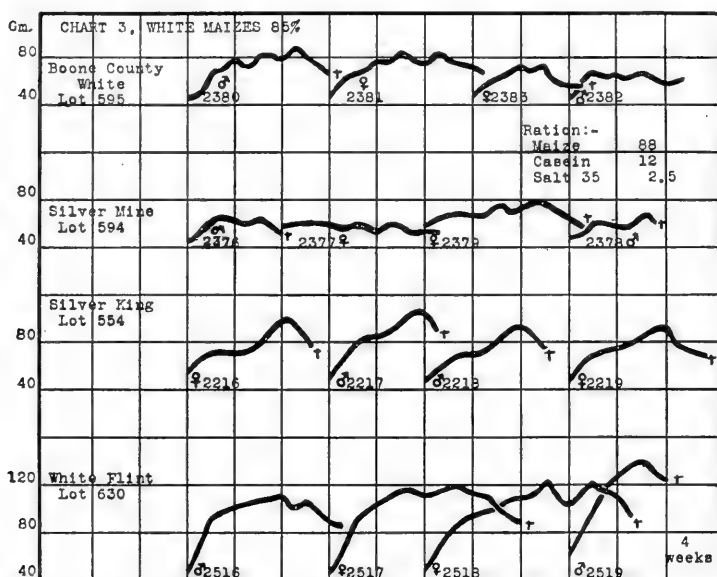

CHART 3.

ences in coat patterns from a group of 50 to 100 of suitable age and size gathered in one cage. In this way the chances are that few if any groups of four consisted of individuals from only one litter and therefore they would be unlikely to have similar inherited tendencies. With this in mind it appears rather remarkable that there should obtain such similarity in the character of the curves of growth of the animals within the groups and such distinguishing features—at least in the amount of growth—among the different groups if differences in nutritive value did not obtain. We are inclined to believe that the better

growth performance of the White Flint group was due to a greater fat-soluble vitamine content. This is noteworthy especially as the White Flint maize though a commercial white corn was not a "dead" white in comparison with the Silver Mine variety. Some allowance must be made for the difference in appearance bound to result in a flint maize as compared with the dent, yet making this allowance this variety appeared to have a distinct tinge of yellow both in the grain and as a meal. We do not care to stress this point reserving our conclusions until appearances are verified by chemical examination, but with the evidence given by the growth curves we believe it highly probable that there are differences in the vitamine content of the so called white maizes corresponding to their degree of yellow pigmentation. Certain it is that all these varieties are far different in their fat-soluble vitamine content from those of the yellow variety.

In the four lots receiving white maize as the sole source of the fat-soluble vitamine in their ration we had abundant demonstration of its deficiency in this constituent by the observed symptom complex which while not entirely specific yet in a large group of animals gives indications of the exact nutritive status with a fair degree of certainty. First in importance there is the failure of growth ending in failure of maintenance of life; second there is the often occurring inflammation of the eyes, a conjunctivitis or xerophthalmia as pointed out by Osborne and Mendel; and thirdly there may prevail the general condition of malnutrition of the skin as indicated by encrustation of the ears, warts on the nose, infection on the tail and feet, and even sores on the body itself. All these occur singly or collectively, but as they are not absolutely specific they are to be considered suggestive symptoms instead. In the group of rats all failed to grow and no doubt all would have died if the experiments had been continued a short time longer as twelve of the sixteen animals died during the time of observation. Of the total, nine had contracted an infection in one or both eyes and three had cutaneous infections.

Comparative Fat-Soluble Vitamine Content of White and Yellow Maizes.

In order to bring out the limitations in the amounts of fat-soluble vitamine in yellow and white maize more concretely than the previous lots had indicated two experimental groups were fed these grains in which 50 instead of 88 parts of the ration—exclusive of the added salts—consisted of maize (Chart 4). The results are obvious. They indicate that with a reduction in the amount of white maize in the ration growth is little worse than with some of the white maizes at the higher level. Unfortunately the white maize fed in this lot was not of any standard variety.

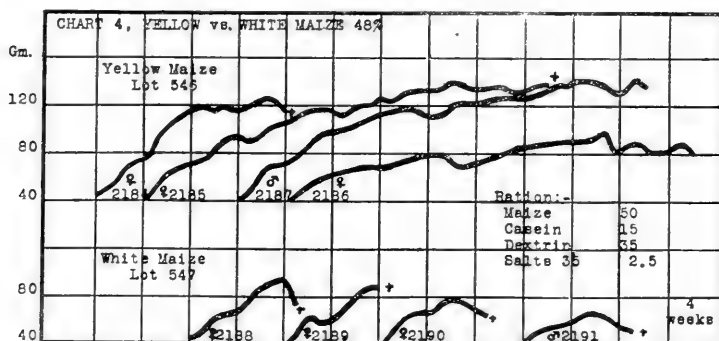

CHART 4.

but was obtained on the local market as a distinctly white variety so direct comparisons are not possible, but apparently it seems safe to infer that certain white maizes contain so little of the fat-soluble vitamine that as a source of this dietary essential they can be considered valueless. This is the only conclusion that can be arrived at when it is seen that a reduction in the amount of white maize in the ration causes so little difference in the resultant growth. Such growth as is observed must be attributed to the fat-soluble vitamine stored in the body of the animal. Three of the animals, *viz.* Rats 2188, 2190, and 2191, developed xerophthalmia, but Rat 2189 died without any visible signs of infection.

With the yellow maize a reduction of the amount in the ration from 85 to 48 per cent gives a definite corresponding reduction in the amount of growth. Growth was possible at only about one-

half the normal rate from which we may infer—as the reduction in maize and therefore vitamine content was approximately 40 per cent—that yellow maize when fed in maximum amounts contains just sufficient fat-soluble vitamine to make normal growth possible.

Fat-Soluble Vitamine Content of Red Maizes.

With a relation between the occurrence of the yellow pigment and the growth-promoting property associated with the fat-soluble vitamine established in the case of yellow maize, it re-

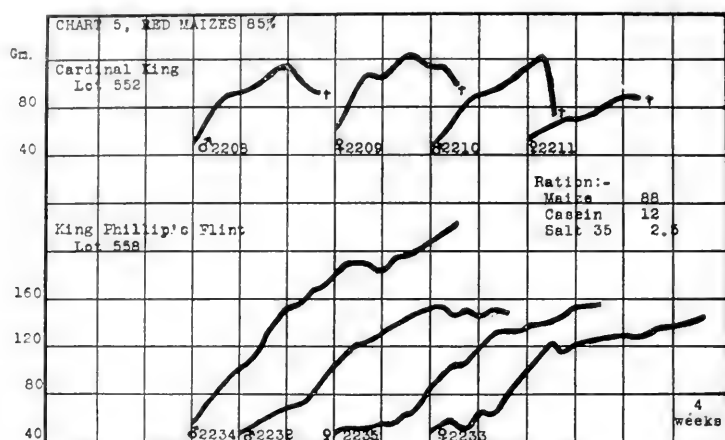

CHART 5.

mained to determine what the situation might be in the case of maizes of other colors. This opportunity presented itself with two varieties known respectively as Cardinal King and King Phillip's Flint. It is seen at a glance in Chart 5 that failure on the former ensued rapidly while on the latter growth continued at a subnormal rate for 22 weeks when the experiment was terminated. The difference can again be correlated with reference to the presence of yellow pigments for while both varieties were red, the Cardinal King had a white endosperm while the King Phillip's Flint had a yellow endosperm; the former has no visible yellow pigments, while the latter has considerable.

The rats on Cardinal King in Lot 552 succumbed to the fat-soluble vitamine deficiency very rapidly, all dying in less than 12 weeks after they had been put on the ration. Their behavior was very similar to those on the white maize, Chart 3. All except Rat 2211 contracted xerophthalmia.

On King Phillip's Flint when the experiment was discontinued—almost 23 weeks after its inauguration—all the animals were rated as being in good condition giving no evidence of eye infections or cutaneous malnutrition.

Fat-Soluble Vitamine Content of Variegated Maize.

Maize, as indicated by the innumerable so called varieties which are grown in the United States, offers many opportunities for the intermingling of characters not only in habit of growth, but also in color. In variegated maize many color characteristics

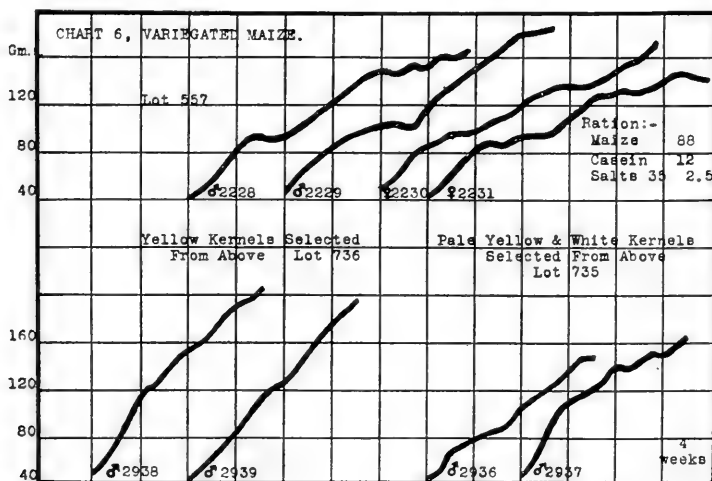

CHART 6.

may be associated in the same kernel or in different kernels on the same cob. Such a maize was the sample whose fat-soluble vitamine content was demonstrated in Lot 557, Chart 6. All the rats grew a little better than one-half the normal rate and were in good condition when the experiment was discontinued.

It is noteworthy that there again the maize fed had a very large proportion of its kernels bearing varying amounts of yellow pigment especially in the endosperm, but some of the kernels were distinctly white and others, when pigmented, had a white endosperm.

It remained to establish how closely the fat-soluble vitamine was associated with the yellow pigments in this sample of maize where color characteristics were so closely interwoven that from the hereditary standpoint it was impossible to predict what the color distribution in the crop from any one kernel would be. To determine this, the seeds predominatingly yellow were selected by hand from those pale yellow or more nearly white. The results are shown in Lots 735 and 736. As before, the intimate association of yellow pigment and the property attributed to the occurrence of the fat-soluble vitamine obtains. We believe all our data substantiate this thesis beyond a doubt.

Supplementation of White Maize with Fat-Soluble Vitamine.

As all our rations, outside of the fat-soluble vitamine, contained all the generally recognized required ingredients of a complete ration and as many of our animals on the white maize rations consistently, singly or collectively, gave all the symptoms of a fat-soluble vitamine deficiency there remains no alternative but to conclude that the failure of rats to grow on white maize rations is due to a lack of fat-soluble vitamine. It seems rather remarkable that these differences in the nutritive value of the maizes should not have been generally recognized especially when it is considered that both are used in large amounts for feeding animals. As a matter of fact it has been reported by some stockmen that yellow maize is superior to white maize, but again by others it has been as stoutly denied. As chemical analysis for determining nutritive values of feeds has indicated no differences in digestible fat, protein, nitrogen-free extract, fiber, and ash, the entire matter has been given little attention in nutrition fields, as the limitations of such analysis have been little realized (4). Chart 7 indicates, if data obtained with rats are applicable to other animals, that from the practical standpoint this difference of opinion may be based on justifiable grounds. Ordi-

narily materials rich in the fat-soluble vitamine are consumed by man, as well as by animals, in sufficient amounts to supplement the fat-soluble vitamine-poor foods efficiently. But under restricted feeding conditions the situation is far different. It ap-

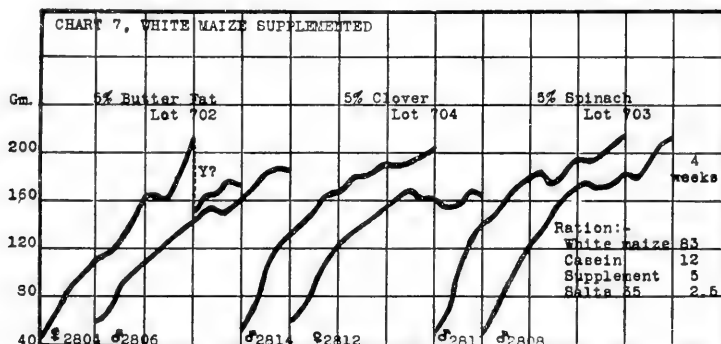

CHART 7.

pears a curious reflection on human instinct that in the United States and Mexico white maize is preferred to yellow maize as a major constituent of the diet, especially when it is considered that this is the case in sections where restricted rations are common.

CONCLUSIONS.

The occurrence of yellow pigment and the growth-promoting property attributed to the presence of the fat-soluble vitamine seem to be intimately associated in the maize kernel.

Yellow maize contains enough of the fat-soluble vitamine to allow growth at the normal rate to take place in the rat; reproduction was possible, but usually was a failure; maintenance without premature signs of senility was also observed.

White maize does not contain any demonstrable amounts of the fat-soluble vitamine. In attempts to have it serve as the source of fat-soluble vitamine it seldom allows rats to remain alive longer than 3 months. One commercially so called white maize allowed a certain amount of growth to take place, but close inspection indicated the presence of some yellow pigment.

Red maize with a white endosperm free from yellow pigment gave the same results as white maize; red maize with a yellow

endosperm gave results though not of the same degree, yet approximately that of yellow maize.

A variegated maize of red, yellow, white, and blue effects due to variation in color distribution in different kernels between pericarp, aleurone layer, and endosperm gave results intermediate between those obtained with yellow and white maize; in correlation most of the kernels had yellow endosperms, the rest had white endosperms.

When from the variegated maize the yellow kernels were selected from those that were white or a very pale yellow and fed to young rats, the performance of growth was distinctly better on the former.

In a mixed diet containing maize the fat-soluble vitamine deficiency of white maize is easily taken care of by the supplementary action of other foods rich in this dietary essential.

BIBLIOGRAPHY.

1. Steenbock, H., and Gross, E. G., *J. Biol. Chem.*, 1919, xl, 501.
2. McCollum, E. V., Simmonds, N., and Pitz, W., *Am. J. Physiol.*, 1916, xli, 374.
3. Steenbock, H., *Science*, 1919, 1, 352.
4. Henry, W. A., and Morrison, F. B., *Feeds and feeding*, Madison, 15th edition, 1915, 150.

EXPLANATION OF PLATE 2.

FIG. 1. Rat 2215, female, after having been fed for 78 days on a ration in which all the fat-soluble vitamine was supplied by 85 per cent of yellow maize. When started on the ration it weighed 59 gm.; when photographed 137 gm. Note its good nutritive condition. For weight record see Chart 1, Lot 553.

FIG. 2. White Rat 2377, female, and hooded Rat 2379, female, after having been fed for 92 days on a ration in which all the fat-soluble vitamine was supplied by 85 per cent of white maize. For weight records see Chart 3, Lot 594. The white individual originally weighed 47 gm.; when photographed it weighed 53 gm. Its ears were infected, but its eyes were normal.

The hooded rat originally weighed 57 gm.; when photographed it weighed 60 gm. Note the encrustation of the ears and the inflamed eye. It died 2 days later.

✓
90



FIG. 1.



FIG. 2.

(Steenbock and Boutwell: Fat-Soluble Vitamine. III.)



PROTEIN REQUIREMENT OF MAINTENANCE IN MAN AND THE NUTRITIVE EFFICIENCY OF BREAD PROTEIN.

BY H. C. SHERMAN.

WITH THE COOPERATION OF L. H. GILLETT AND EMIL OSTERBERG.

(From the Department of Chemistry, Columbia University, New York.)

(Received for publication, November 13, 1919.)

In connection with our studies of nutritive requirements and of the efficiency of the proteins of the cereal grains in the maintenance metabolism of man¹ we have taken occasion to bring together the results of such of the earlier experiments upon the protein requirement of maintenance as seem to lend themselves to direct quantitative comparison. The purpose of the present paper is to present as concisely as possible the net result of this study of the literature together with the data of our own experiments upon a dietary in which nearly all the nitrogen was taken in the form of wheat bread.

An attempt to determine the protein requirement of maintenance, even for any one kind of protein, would ideally involve adherence to an otherwise uniform diet with complete findings of nitrogen intake and output and with periodical increase or decrease of protein consumption without alteration of the energy supply, until it is shown that the body can maintain itself in nitrogen equilibrium on a certain amount of protein, of the kind or kinds which the diet in question furnishes, and not on any smaller amount. The recorded investigations which meet all these conditions are not sufficiently numerous, nor do they cover a sufficient number of men and women or a sufficient range of foods to form a satisfactory basis for any general deduction as to

¹ Sherman, H. C., Gillett, L. H., and Pope, H. M., *J. Biol. Chem.*, 1918, xxxiv, 373. Sherman, H. C., Wheeler, L., and Yates, A. B., *ibid.*, 1918, xxxiv, 383. Sherman, H. C., and Winters, J. C., *ibid.*, 1918, xxxv, 307. Sherman, H. C., Winters, J. C., and Phillips, V., *ibid.*, 1919, xxxix, 53.

the amount of protein required in normal adult maintenance. In attempting such a deduction, proper consideration must also be given to the much larger number of experiments in which the balance of intake and output of nitrogen has been determined with subjects living on low protein diets under conditions so arranged and controlled as to make it probable that the rate of protein metabolism was at least approximating the minimum at which normal equilibrium could be maintained.

Probably the best present indication of the normal protein or nitrogen requirement is to be obtained by averaging the observed nitrogen output in all available experiments in which the intake appears to have been barely sufficient or not quite sufficient to result in equilibrium of intake and output.

Since the protein minimum thus determined is influenced by the protein-sparing action of carbohydrates and fats, the results will be comparable, and will bear directly upon the practical problems of protein requirement in food economics, only in those cases in which the energy value of the experimental ration is at least approximately adjusted to the energy requirement of the subject.

Many of the published experiments which were designed to test the amounts of protein required in normal nutrition are now seen to have given misleadingly high results either because the food was reduced as a whole, thus creating a deficit in the energy intake which interfered with the economical use of the protein, or because, influenced by past overestimates of the protein requirement, the experimenters did not sufficiently reduce the amount of protein in the food to make a real test of the minimum on which equilibrium could be established and maintained.

Given a proper adjustment of the energy value and a sufficiently restricted proportion of protein in the experimental ration, the question arises as to how closely the nitrogen output must agree with the intake in order that it may be accepted as indicating the approximate requirement of the subject under the conditions of the experiment.

A plus balance or exact equilibrium of nitrogen intake and output always suggests the question whether equilibrium might not have been again established if the nitrogen intake had been further reduced, in which case the given result was obviously higher than the amount actually required. Whether the observed

output is such an overestimate or is a fair approximation to the amount really required for equilibrium can often be judged with a fair degree of confidence from a detailed and critical study of the investigation as a whole. At any rate, when there is nitrogen equilibrium on a low protein intake it seems safe to conclude that the diet is at least meeting all the requirements of the protein metabolism of maintenance.

Also, when the nitrogen output is only slightly greater than the intake it seems permissible to regard the output as approximating the amount on which equilibrium could have been maintained; for while it is conceivable that a small loss of body nitrogen may represent a real inadequacy of the intake, perhaps as regards some particular amino-acid, yet it is usually much more probable that a small negative balance means simply that the body has not yet completed the adjustment of its output to its intake and that a continuation of the experiment would have shown a lower output. Thus while it is possible that the output may sometimes be smaller than the amount which would be required for equilibrium, yet from the large amount of evidence now available it seems fairly certain that any error of this sort can have but very slight influence upon the final average, and in all probability is more than offset by the tendency toward high results introduced through including in the average a considerable number of experiments in which the protein of the diet was not reduced to a sufficient extent, and for a long enough time, to show the real minimum at which normal equilibrium could be maintained.

In order to minimize the personal equation in our interpretation of the work of others, we have uniformly excluded from Table I all experiments showing a loss of body nitrogen greater than 1 gm. per day even though in some cases this necessitated the omission of data of undoubted value.

There remained 109 experiments belonging to twenty-five different investigations and including 67 experiments upon twenty-nine men and forty-two experiments upon eight women subjects. For convenience of comparison the total nitrogen output per day (urine and feces) is computed to a basis of 70 kilos of body weight and multiplied by 6.25 to express the corresponding amount of protein which is tabulated as the "indicated protein requirement" in each of the 109 experiments as shown in Table I.

TABLE I.*

Indicated Protein Requirements per 70 Kilos of Body Weight.

Experi- ment No.	Indi- cated protein require- ment.	Experi- ment No.	Indi- cated protein require- ment.	Experi- ment No.	Indi- cated protein require- ment.	Experi- ment No.	Indi- cated protein require- ment.	Experi- ment No.	Indi- cated protein require- ment.
	gm.		gm.		gm.		gm.		gm.
1	39	23	45	45	31	67	56	89	37
2	38	24	49	46	37	68	57	90	38
3	45	25	56	47	45	69	60	91	39
4	33	26	47	48	50	70	57	92	39
5	30	27	62	49	39	71	54	93	39
6	65	28	61	50	52	72	51	94	43
7	61	29	55	51	52	73	52	95	40
8	41	30	53	52	42	74	54	96	39
9	50	31	53	53	42	75	54	97	43
10	43	32	61	54	24	76	53	98	38
11	37	33	40	55	21	77	53	99	37
12	29	34	56	56	33	78	44	100	33
13	59	35	43	57	32	79	45	101	37
14	57	36	42	58	32	80	46	102	41
15	49	37	41	59	39	81	46	103	51
16	42	38	39	60	50	82	42	104	44
17	50	39	48	61	58	83	41	105	42
18	48	40	46	62	37	84	36	106	32
19	49	41	38	63	41	85	38	107	35
20	54	42	47	64	44	86	39	108	34
21	36	43	36	65	59	87	39	109	32
22	47	44	37	66	60	88	38		
Average.....									44.4

* Experiments 1 and 2, Hirschfeld, F., *Arch. ges. Physiol.*, 1887, xli, 533. No. 3, Hirschfeld, F., *Virchows Arch. path. Anat.*, 1888, cxiv, 301. Nos. 4 and 5, Klemperer, G., *Z. klin. Med.*, 1889, xvi, 550. Nos. 6 and 7, Viot, C., *Z. Biol.*, 1889, xxv, 232. No. 8, Pechsel, Eiweissbedarf des gesunden Mensch., Dissertation, Berlin, 1890 (*U. S. Dept. Agric., Bull.* 45, 1895). No. 9, Lapieque, L., *Arch. Physiol.*, 1894, Series 5, vi, 596. Nos. 10 and 11, Sivén, V. O., *Skand. Arch. Physiol.*, 1900, x, 91. No. 12, Sivén, V. O., *ibid.*, 1901, xi, 308. No. 13, Albu, *Z. klin. Med.*, 1901, xliii, 75. Nos. 14 to 20, Jaffe, M. E., *U. S. Dept. Agric. Bull.* 132, 1902. No. 21, Caspari, W., and Glaessner, K., *Z. diät. physik. Therap.*, 1903, vii, 475. Nos. 22 to 33, Chittenden, R. H., *Physiological economy in nutrition*, New York, 1904. No. 31, Aron, H., and Hoeson, F., *Biochem. Z.*, 1911, xxxii, 189. Nos. 35 to 38, Hindhede, M., *Skand. Arch. Physiol.*, 1912, xxvii, 277; Nos. 39 to 46, 1913, xxx, 97; Nos. 47 to 55, 1914, xxxi, 259. Nos. 56 to 61, Abderhalden, E.,

The 67 experiments upon men show an average "indicated protein requirement" of 0.633 gm. per kilo, while the 42 experiments with women average 0.637 gm. per kilo of body weight. It seems unnecessary, therefore, to distinguish between the sexes in this discussion since we are dealing with data calculated to a uniform basis of body weight.

The general average of the 109 experiments shows an indicated requirement of 0.635 gm. of protein per kilo of body weight, or 44.4 gm. per "average man" of 70 kilos, per day. Two considerations, one favorable the other unfavorable, should be kept in mind in attempting to judge the scientific value of this average. On the one hand, it represents a very large amount of work in several different laboratories and on many subjects, both men and women, so that errors due to individual peculiarities of subjects, diets or conditions, or the personal equation of the investigator are minimized. On the other hand, the data of individual experiments are rather divergent, ranging from a minimum of 21 gm. to a maximum of 65 gm. per 70 kilos. It should perhaps be noted that the very large majority of these experiments (94 in 109) yield values within the limits of 29 to 56 gm. per 70 kilos, and that these more concordant data taken separately show an indicated protein requirement averaging 42.8 gm. per 70 kilos based on 94 experiments covering thirty-four subjects (twenty-six men and eight women) studied in twenty-three different investigations. If we go a step further in rejecting the extremes, we find within the limits of 30 to 50 gm. per 70 kilos per day, 76 experiments belonging to nineteen different investigations, including twenty-four subjects (twenty men and four women) and averaging 40.6 gm. per man of 70 kilos, or 0.58 gm. per kilo of body weight per day.

Ewald, G., Fodor, A., Röse, C., *Arch. ges. Physiol.*, 1914-15, clx, 511. Nos. 62 to 64, Rose, M. S., and Cooper, L. E., *J. Biol. Chem.*, 1917, xxx, 201.) Nos. 65 to 72, Sherman, H. C., Gillett, L. H., and Pope, H. M., *ibid.*, 1918, xxxiv, 373. Nos. 73 to 77, Sherman, H. C., Wheeler, L., and Yates, A. B., *ibid.*, 1918, xxxiv, 383. Nos. 78 to 93, Sherman, H. C., and Winters, J. C., *ibid.*, 1918, xxxv, 301. Nos. 94 to 102, Sherman, H. C., Winters, J. C., and Phillips, V., *ibid.*, 1919, xxxix, 53. Nos. 103 and 104, Sherman, H. C., and Rose, A. R., not previously published. No. 105, Sherman, H. C., and Beegle, F. M., not previously published. Nos. 106 to 109, Sherman, H. C., and Osterberg, E., not previously published.

Thus according as we include all 109, or 94, or 76 experiments in the average it becomes respectively 0.635, 0.61, or 0.58 gm. per kilo, or in round numbers 45, 43, or 41 gm. per man of 70 kilos per day. It will be noted that the more critical the selection of the experiments to be included in the average the lower the indicated protein requirement becomes. There would appear to be a smaller probable error in estimating the average protein requirement at about 0.6 gm. per kilo, or 42 gm. per 70 kilos, per day, than at any higher figure. It should also be noted that the final data of nearly all the more extended and the more closely controlled investigations fall below rather than above this average.

From a general review of all the experiments included in this compilation it appears to us that the chief cause of variation was the differing duration of the investigations and the differing extent to which the subject had accustomed himself to a low protein diet. In the work thus far published this seems to have been a more influential factor in determining the amount of protein apparently required for maintenance in the human adult than was the nature of the protein fed.

We have previously shown that the protein of rations consisting essentially of corn (maize) meal or oatmeal supplemented by only small amounts of milk, the latter furnishing but one-tenth to one-fifth of the food protein, may be fully as efficient in the maintenance metabolism of man as the average protein of ordinary mixed diets has been found to be in the work of previous investigators. Because of the large extent to which the majority of the people of this country and of Europe depend upon bread as their chief source of protein as well as energy, it seems well to give in this connection the data of our chief series of experiments in which ordinary (white) wheat bread furnished almost all the protein of the food.

Experiments upon the Efficiency of Bread Protein in Maintenance Metabolism.—The subject, E. O., a man weighing 80 kilos, took on each of 15 successive days a ration consisting of 400 gm. of bread, 150 (or, during the last 6 days, 200) gm. of butter, and 300 gm. of apple. The 15 days were divided into five experimental periods of 3 days each, the foods and feces being collected, sampled, and analyzed separately for each of these periods. Urine was collected and analyzed separately for each 24 hours. The work

thus constitutes a series of five complete balance experiments each of 3 days duration and following each other without intermission. The data of nitrogen intake and output are shown in Tables II and III.

In these experiments bread furnished over 95 per cent of the protein consumed, yet allowing the first 3 days for adjustment it will be seen that practical equilibrium was maintained on an intake of a little less than 0.5 gm. of protein per kilo of body weight per day. Thus the protein of wheat bread showed as high an efficiency in the maintenance metabolism of man as would be expected of the protein of mixed diet in general. The bread was ordinary white bread purchased from a New York City

TABLE II.

Food Eaten with Daily Intake of Nitrogen from Each Source. Experiments with E. O., Weight 80 Kilos.

Kind of food.	Experiment 1.	Experiment 2.	Experiment 3.	Experiment 4.	Experiment 5.
	<i>gm.</i>	<i>gm.</i>	<i>gm.</i>	<i>gm.</i>	<i>gm.</i>
Bread.....	400	400	400	400	400
Butter.....	150	150	150	200	200
Apple.....	300	300	300	300	300
Nitrogen from bread.....	5.77	5.87	5.76	5.71	5.72
“ “ butter.....	0.13	0.13	0.13	0.18	0.18
“ “ apple.....	0.11	0.09	0.11	0.11	0.12
Total per day.....	6.01	6.09	6.00	6.00	6.02
Protein per day.....	38	38	38	38	38

bakery. Probably the customary small amount of milk was used in making the bread—exactly how much or in what form we were not permitted to ascertain. That the bread did not contain any unusual proportion of milk or milk powder was shown by determining its content of phosphorus and calcium as well as of nitrogen.

Thus it does not seem necessary to discriminate against bread protein as compared with the protein of staple foods in general in so far as the requirements of adult maintenance alone are concerned. This result is in opposition to the claims of Karl Thomas but is in accordance with the findings of Hindhede and of Morgan

and Hintze in their experiments upon man, as well as with the work of this laboratory on the efficiency of maize and oat proteins in adult human nutrition, and is in harmony with the findings both of Osborne and Mendel and of McCollum and his

TABLE III.
Daily Intake and Output of Nitrogen. Experiments with E. O.

Experiment No.	Day.	Body weight.	Nitrogen.				
			In food.	In urine.	In feces.	Output.	Balance.
		<i>kg.</i>	<i>gm.</i>	<i>gm.</i>	<i>gm.</i>	<i>gm.</i>	
1	1st	81.0	6.0	6.6			
	2nd		6.0	6.6			
	3rd		6.0	6.6			
Average			6.0	6.6	0.7	7.3	-1.3
2	4th	80.5	6.1	5.5			
	5th		6.1	4.3			
	6th		6.1	5.1			
Average			6.1	5.0	0.9	5.9	+0.2
3	7th	80.5	6.0	5.2			
	8th		6.0	5.4			
	9th		6.0	5.7			
Average			6.0	5.4	1.0	6.4	-0.4
4	10th	80.5	6.0	6.0			
	11th		6.0	4.5			
	12th		6.0	5.2			
Average			6.0	5.2	1.0	6.2	-0.2
5	13th	80.3	6.0	4.5			
	14th		6.0	5.1			
	15th	79.8	6.0	4.7			
Average			6.0	4.8	1.0	5.8	+0.2

associates that the proteins of cereal grains need only be fed in very moderate quantity to provide for the maintenance of body weight in adult rats. Thus Osborne and Mendel found the body weight maintained by food mixtures which contained only

^t 6.5 to 7 per cent of the proteins of the whole wheat kernel,² which, as these food mixtures contained about 25 per cent fat, would mean that wheat protein sufficient to furnish from 5 to 6 per cent of the total calories of the food consumed was sufficient for maintenance. McCollum³ gives 4.5 per cent of oat protein or 6 per cent of wheat or maize protein as the proportion necessary to maintain body weight in adult rats. In McCollum's food mixtures the percentage of protein by weight would be about the percentage of protein calories in the total calories of the food.

Thus the feeding experiments upon rats are fairly consistent in indicating that the amount of grain protein required for adult maintenance (in this case judged by body weight) is about 6 per cent of the total food calories. Turning to the experiments upon the maintenance of nitrogen equilibrium in man, we see from the data above cited an indicated average protein requirement of about 0.6 gm. of protein per kilo of body weight per day. This corresponds to 2.4 protein calories, or 6 per cent of the 40 calories per kilo which is commonly accepted as a fair average energy requirement for moderately active men and women. Thus it would appear that the protein minimum for normal adult maintenance is very similar for man and the rat if the protein is stated in terms of the total calories of food consumed. It does not necessarily follow that the protein requirement of growth will be proportionately as high for the child as for the young rat. The percentage rate of growth is very much greater in the young rat than in the child and healthy children are usually more active than the average of young rats at corresponding stages of growth. From these facts it is to be expected that the requirement for protein relative to calories will be greater in the case of the young rat than of the child at a corresponding stage of development. Relative to body weight, the protein requirement of growth is of course higher than that of maintenance, in either species. Of at least equal importance is the fact that the amino-acid make-up of the food protein is a more prominent factor in the problem of growth than in that of maintenance. In connection with the well known work of Hopkins, of Osborne and Mendel, and of

² Osborne, T. B., and Mendel, L. B., *J. Biol. Chem.*, 1919, xxxvii, 557.

³ McCollum, E. V., *Newer knowledge of nutrition*, New York, 1918, 75.

McCullum this fact has been discussed in terms of the functions of individual amino-acids both as tissue constituents and as possible precursors of hormones and it has been suggested that the protein requirement of maintenance may actually be a requirement for certain amino-acids for transformation into hormones, that the repair processes of maintenance may not involve the disruption and resynthesis of entire protein molecules, or that some of the amino-acids may be used over again in the repair processes. It may also be helpful to think of the protein metabolism not only in terms of building and repair, but also of maintaining the equilibrium which exists between proteins and amino-acids in the cells of the animal tissues. In such a cell there is a constant tendency toward removal of amino-acids by deamination, offset by the inflow of amino-acids derived from food protein and brought to the tissue cell by the blood stream. Concentration of any of the amino-acids into which tissue proteins tend to be hydrolyzed may therefore be expected to help in pushing the reaction, **amino-acids** \rightleftharpoons **protein**, toward the right; in other words, *any* of these amino-acids will function in the *maintenance* of body protein, whereas for the synthesis of new protein as in *growth*, *all* the amino-acids would be needed. Hence it is quite reasonable that proteins of very different efficiency for growth may show much more nearly equal efficiency in the normal maintenance nutrition of adults.

It is well known that as a group the proteins of the cereal grains are less rich in certain amino-acids essential to animal tissue, notably lysine and tryptophane, than are several other of the food proteins; and it is reasonable to expect that such differences in chemical structure among proteins imply corresponding differences in nutritive efficiency. But deficiencies established by experiments with isolated proteins do not necessarily imply corresponding deficiencies in the nutritive value of the natural mixtures of proteins found in our ordinary articles of food. Most experiments designed to compare the nutritive efficiencies of the proteins of different foods have been performed upon laboratory animals during growth, since the nutritive requirements of growth naturally tend to accentuate the differences of food value among proteins which the experiments are designed to discover or demonstrate. Largely for the same reason, however, there is

danger that generalizations from such experiments may lead to exaggerated impressions. On the other hand, we would avoid giving an exaggerated impression in the other direction when we point out that any amino-acid such as results from hydrolysis of body protein may be expected to function in the maintenance metabolism. It is not probable that a molecule of tissue protein is hydrolyzed into a great number of molecules of amino-acids, of for example, fifteen different kinds, in a single step. Autolysis experiments indicate rather that there are successive splittings more or less similar to those which occur in digestive proteolysis, with liberation of amino-acids throughout the process as well as at the end. Any one amino-acid, then, could be expected to check the process only at the point at which that amino-acid would be liberated from the catabolizing protein molecule. If, however, we feed a protein which furnishes considerable amounts of, for example, twelve out of fifteen of the amino-acids in question, then even though the three which are lacking are strictly essential there will still be twelve chances in fifteen of checking the catabolism of the body protein at an early stage, with corresponding efficiency of the incomplete food protein in the protein metabolism of maintenance.

The efficiencies actually found in our typical experiments in which the protein consumed was almost entirely in the form of ordinary wheat bread, or of hard bread made from corn-meal or oatmeal, may be summarized as follows.

Subject R, a man of 80 kilos, established nitrogen equilibrium on a diet of 400 gm. of white wheat bread, 200 gm. of butter, and 300 gm. of apple per day furnishing in all 2,700 calories and 6.0 gm. of nitrogen of which latter 96 per cent was in the form of bread. Thus 37.5 gm. of protein for a man of 80 kilos, corresponding to 33 gm. for a man of average weight (70 kilos), sufficed for the maintenance of normal equilibrium.

Subject O, a woman of 55 kilos, maintained approximate equilibrium (losing less than 0.5 gm. of nitrogen per day) on a diet of corn-meal, butter, sugar, and apple which furnished 2,030 calories and 4.36 gm. of nitrogen per day, all the latter being maize protein except the small amount furnished by the apple. The actual intake of protein was 27 gm. per day. This corresponds to 34 gm. of protein per 70 kilos of body weight per

day. When 100 gm. of milk were added to the diet, making the actual intake of protein 30 gm. (equivalent to 37 gm. per 70 kilos) of which 88 per cent was from corn-meal, 10 per cent from milk, and 2 per cent from apple, the protein supply proved more than sufficient and the subject stored nitrogen. To compare these data with those of the preceding series would somewhat unduly favor the wheat in the comparison since Subject R was considerably older than Subject O and carried a larger proportion of adipose tissue. Under the circumstances, therefore, it seems proper to conclude that the corn protein has shown itself equally efficient with that of wheat in these experiments.

The experiments upon the efficiency of the proteins in oatmeal were carried out with two young women as subjects. The first, Subject O, weight 55 kilos, was the same who had served in the corn-meal experiments just described. The second, Subject P, weighed 67 kilos. Corn-starch was mixed with the oatmeal in such proportions that the cereal part of the diet should furnish practically the same proportions of protein, starch, and calories as in the experiments with corn-meal. The other foods of the experimental diet were substantially as in the corn-meal experiments. Subject O here took the same amount of oat protein which she had taken of corn protein previously. Subject P took amounts of food approximately in proportion to her higher body weight. The main periods of the oatmeal experiment were made parallel to that in which Subject O had taken with the corn-meal diet 100 gm. of milk per day and had stored a small amount of nitrogen. With the oatmeal diet and 100 gm. of milk, Subject O showed nitrogen equilibrium and Subject P a slight storage. In the shorter periods without milk the losses of body nitrogen though small were slightly larger than in the corresponding experiments with corn-meal. It is doubtful if the differences are larger than may be due to the unavoidable fluctuations of nitrogen output in such experiments. The results indicate therefore that the protein of the oatmeal was practically as efficient as the protein of wheat flour or corn-meal.

With all three of the cereal grains tested (wheat, maize, and oats) it was found that a diet, in which about nine-tenths of the protein was derived from the cereal in the form commonly used as human food, the small remainder being furnished by milk or

apple, need contain only 33 to 40 gm. of protein per 70 kilos of body weight, or about 0.5 gm. per kilo, in order to meet the protein requirement of maintenance in adult human nutrition.

The proteins of wheat, corn, and oats appear to be about equally efficient in adult human nutrition and need only be supplemented with small amounts of milk in order to be fully as efficient as the proteins of ordinary mixed diets have been found to be in earlier investigations. Our findings for these cereal proteins are therefore similar to that of Hindhede for wheat bread and show their efficiency to be much higher than was reported by Karl Thomas for either wheat or maize.

Thus from the more recent and more carefully controlled experiments it appears that, even when the protein of the food is almost entirely derived from bread or other grain products, with a diet adequate in energy value a daily intake of about 0.5 gm. of protein per kilo of body weight is sufficient to meet the actual requirements of maintenance in healthy men and women. While if numerous older experiments having a tendency to high results are included the average is somewhat less than $\frac{2}{3}$ gm. of protein per kilo of body weight. A standard allowance of 1 gm. of protein per kilo of body weight per day appears, therefore, to provide a margin of safety of 50 to 100 per cent as far as the requirements of adult maintenance are concerned.

It is plainly desirable in all cases that grain products be supplemented by milk products, and it is clear that in providing for needs of growing children and of pregnant or nursing mothers the proportion of milk in the diet should be more liberal than it need be when only maintenance is concerned; this both because of the superior amino-acid make-up of the milk proteins and to provide amply for the mineral elements and vitamins as well.

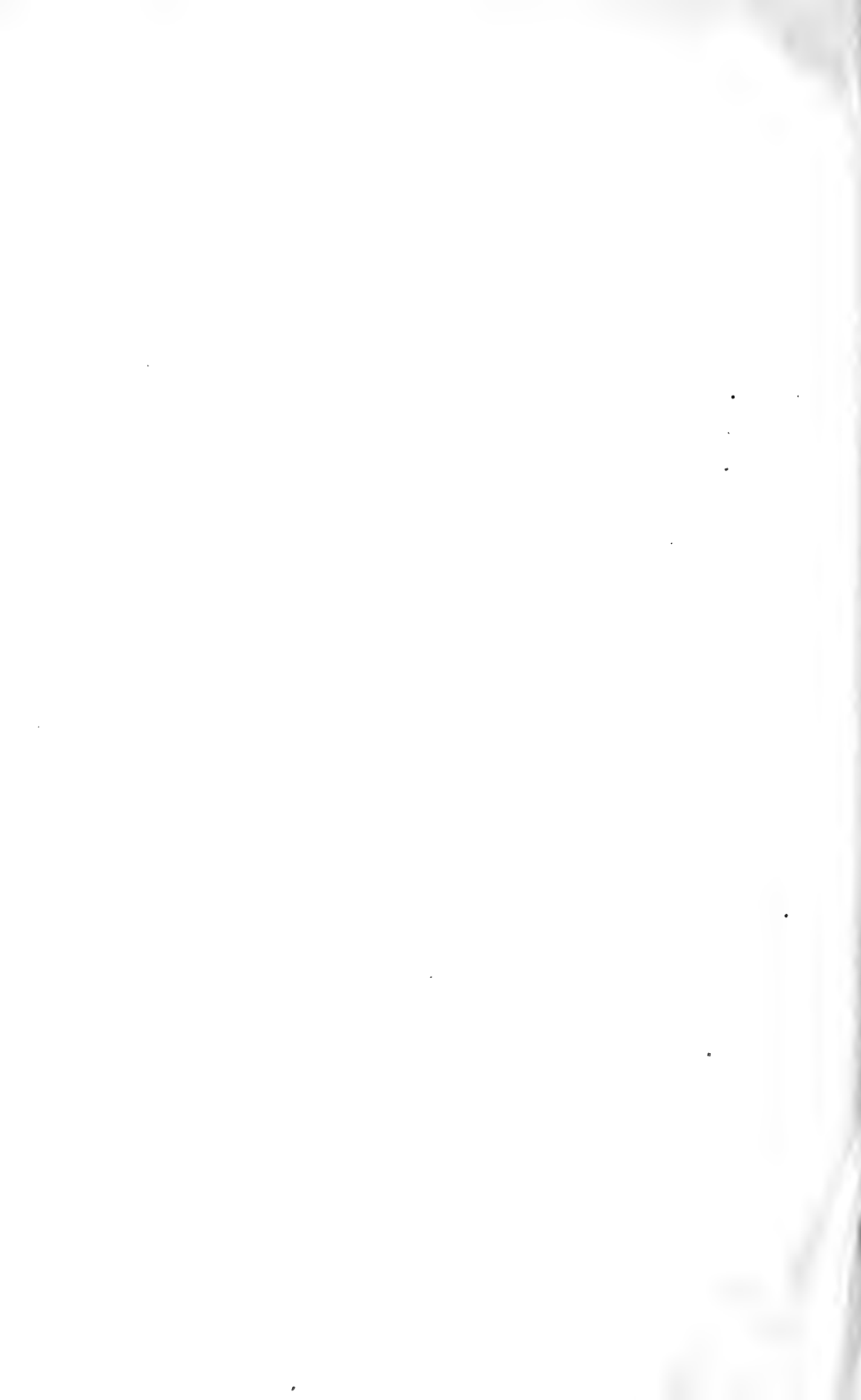

EFFECT OF IODIDES ON THE AUTOLYSIS OF LIVER TISSUE.

By P. G. ALBRECHT.

*(From the Laboratory of Physiological Chemistry, College of Medicine,
University of Illinois, Chicago.)*

(Received for publication, November 10, 1919.)

INTRODUCTION.

The medical literature affords much information concerning the therapeutic value of iodides among which may be mentioned germicidal action, stimulation of the production of opsonins, causation of leucocytosis, increased flow of lymph, and promotion of absorption by increasing the permeability of the vessel walls, but very little can be gathered regarding the chemical changes which the various iodine compounds undergo in the body. Their action on the tissue of the liver, lung, and spleen has been studied by Kepinow (1), but faulty technique has in general yielded inconclusive results as Kaschiwabara (2) demonstrated. Administration of KI was found to accelerate autolysis by Stookey (3) and Kepinow. KI added directly to comminuted liver tissue gave no or little acceleration. The slight acceleration is attributed by Morse (4) to increased acidity from liberation of HI. It is difficult to see how this could occur and no experimental proof is furnished. Considering the question of autolysis from the standpoint of protein cleavage, the literature offers but little information. I have therefore undertaken to examine the effects of NaI on the autolysis of liver proteins.

EXPERIMENTAL.

In order to make the results of the investigation comparable with those of others, the methods of Bradley and Morse (5) were employed with the introduction of a few minor modifications; first, instead of filtering the digest through filter paper it was

TABLE I

NaI solution, <i>P. roseol.</i>	days										2.94	
	13.0	0.03	0.05	0.1	0.15	0.25	0.50	0.75	1.00	1.5		
Total nitrogen, cc.	13.0	13.0	13.0	11.10	11.99	11.99	11.99	11.99	11.99	11.99	11.96	
Dissolved nitrogen, control, cc.	1	3.75	3.60	3.82	3.25	3.50	3.50	3.50	3.50	3.50	3.50	3.50
	2	5.96	6.00	5.60	4.60	5.40	5.40	5.40	5.40	5.40	5.40	5.40
	4	6.06	6.46	6.36	4.70	6.00	6.00	6.00	6.00	6.00	6.00	6.00
	6	7.00	7.00	6.76	5.20	7.16	7.16	7.16	7.16	7.16	7.16	7.16
	8	7.50	7.40	7.00	5.40	7.66	7.66	7.66	7.66	7.66	7.66	7.66
Dissolved nitrogen + NaI solution, cc.	1	3.75	3.60	3.82	3.25	3.50	3.50	3.50	3.50	3.50	3.50	3.50
	2	5.60	5.76	5.60	4.86	6.20	6.20	6.00	5.80	5.80	5.70	5.36
	4	6.56	6.36	5.90	5.00	6.10	6.06	6.30	6.10	6.20	6.00	6.16
	6	6.90	6.90	6.50	5.16	7.00	6.90	7.20	7.10	6.60	6.66	7.20
	8	7.36	7.36	6.96	5.56	7.60	7.46	8.00	7.56	7.40	7.36	7.76
Dissolved ammonia nitrogen, control, cc.	1	0.80	0.80	0.80	0.80	0.80	0.80	0.80	0.80	0.80	0.80	0.80
	2	1.00	1.00	1.00	1.00	1.00	1.00	1.00	1.00	1.00	1.00	1.00
	4	1.20	1.20	1.20	1.20	1.20	1.20	1.20	1.20	1.20	1.20	1.20
	6	1.30	1.30	1.30	1.40	1.40	1.40	1.40	1.40	1.40	1.40	1.40
	8	1.50	1.40	1.40	1.40	1.40	1.40	1.40	1.40	1.40	1.40	1.40
Dissolved ammonia nitrogen + NaI solution, cc.	1	0.80	0.80	0.80	0.80	0.80	0.80	0.80	0.80	0.80	0.80	0.80
	2	1.00	1.00	0.90	1.00	1.00	1.00	1.10	1.20	1.00	1.00	1.00
	4	1.20	1.10	1.00	1.30	1.20	1.20	1.40	1.40	1.40	1.30	1.40
	6	1.30	1.20	1.30	1.30	1.40	1.40	1.40	1.40	1.40	1.40	1.50
	8	1.40	1.40	1.40	1.50	1.50	1.40	1.50	1.40	1.40	1.40	1.50

TABLE I.—*Concluded.*

NaI solution, per cent.....	0.03	0.03	0.05	0.1	0.1+	0.25+	0.5+	0.75+	1.0+	1.5+	2.0+
	13.0	13.0	13.0	11.10	11.90	11.90	11.90	11.90	11.90	11.90	11.90
Total nitrogen, cc.....											
	<i>days</i>										
Cleavage ammonia nitrogen +NaI solution, cc.	2	0.20	0.10	0.20	0.20	0.30	0.20	0.30	0.20	0.20	0.20
	4	0.40	0.40	0.30	0.40	0.50	0.60	0.70	0.60	0.60	0.60
	6	0.60	0.50	0.40	0.60	0.60	0.60	0.70	0.60	0.60	0.70
	8	0.70	0.60	0.60	0.80	0.70	0.60	0.80	0.60	0.60	0.70
Cleavage amino nitrogen, con- trol, mg.	2	1.80	2.00	3.60	2.80	3.80	3.80	3.80	3.80	3.80	3.80
	4	4.40	5.40	6.60	6.20	9.20	9.20	9.20	9.20	9.20	9.20
	6	7.80	7.20	10.20	8.80	10.60	10.60	10.60	10.60	10.60	10.60
	8	8.20	9.40	11.00	11.60	13.60	13.60	13.60	13.60	13.60	13.60
Cleavage amino nitrogen +NaI solution, mg.	2	2.00	2.80	3.00	3.40	4.20	4.20	4.20	3.60	3.20	4.20
	4	4.80	5.20	6.00	6.60	8.60	8.60	8.20	10.00	8.40	8.80
	6	8.00	7.80	9.60	8.60	10.80	11.80	11.00	10.60	10.60	11.20
	8	8.40	9.20	11.40	12.00	12.80	12.80	13.00	11.80	10.60	11.40

centrifuged until the supernatant liquid was free from visible solid particles, and second, the tannin precipitation method (6) was replaced by the aluminium cream method (7). Ammonia and amino-acid production during the process of liver autolysis in presence of iodides has never been determined.

DISCUSSION.

According to Morse, KI solution of a concentration of 0.2 to 1.0 per cent slightly accelerates autolysis, with inhibition above 1.0 per cent. The results of this investigation confirm his findings only to some extent.

The results in Table I are expressed in cc. of 0.2 N HCl, except that amino nitrogen is expressed in mg. per 1 gm. of fresh liver tissue. The figures in Column 2 indicate the intervals of days: 1 = immediately; 2 = after 2 days; 4 = after 4 days; 6 = after 6 days; 8 = after 8 days.

Dissolved nitrogen (total), dissolved ammonia nitrogen, and dissolved amino nitrogen were determined in the centrifugalized digest.

Cleavage nitrogen (total), cleavage ammonia nitrogen, and cleavage amino nitrogen were determined in the filtrate from the aluminium cream precipitation method.

The results in Table II are obtained by subtracting the control figures from those of the iodides, and the result is multiplied by 100. In concentrations of sodium iodide from 0.1 to 1 per cent an increase is observed especially in the dissolved nitrogen, in the earlier days of incubation. Higher iodide concentration, from 1.5 to 2 per cent, tends also to give higher figures for this nitrogen. However, this proves by no means that NaI is responsible for this increase as far as its action as stimulus for proteolysis is concerned. On the contrary if sodium iodide behaves as other inorganic neutral salts do, according to Preti (8), it would inhibit instead of accelerate proteolysis, when employed in these concentrations. There is further a possibility that the ionized sodium iodide is responsible for the formation of soluble ion-protein compound which behaves in many respects as soluble protein.

116 Iodides and Autolysis of Liver Tissue

A slight variation in dissolved ammonia nitrogen and cleavage ammonia nitrogen is noticed, which I am not in a position to explain.

TABLE II.

NaI solution, per cent.		0.03	0.03	0.05	0.1	0.1	0.25	0.5	0.75	1.0	1.5	2.0
	<i>days</i>											
Dissolved ni- trogen (N), cc.	2	-36	-24	0	26	6	80	60	40	40	10	-4
	4	-10	-10	-46	30	10	6	30	10	20	0	16
	6	-10	-10	-26	-4	-16	-26	4	-6	-56	-50	4
	8	-14	-4	-4	16	-6	-20	34	-10	-26	-30	10
Dissolved am- monia nitro- gen (NH ₃ - N), cc.	2	0	0	-10	0	0	0	10	20	0	0	0
	4	0	-10	-20	10	10	0	20	20	20	10	20
	6	0	-10	0	10	0	0	0	0	0	0	10
	8	-10	0	0	10	10	0	10	0	0	0	10
Dissolved am- ino nitrogen (NH ₂ -N), mg.	2	-60	40	100	-20	-40	40	20	40	60	0	-60
	4	-40	0	80	40	0	100	100	0	220	80	240
	6	-40	60	-40	40	220	200	120	120	80	0	20
	8	20	60	20	-60	-20	-100	0	20	-120	-280	-280
Cleavage ni- trogen (N), cc.	2	-16	0	10	0	-4	-10	-10	-10	0	0	0
	4	0	4	-6	0	6	20	6	6	16	10	6
	6	-10	-10	6	20	-10	14	0	-6	4	-30	20
	8	0	10	4	-14	4	14	6	6	0	-60	4
Cleavage am- monia nitro- gen (NH ₃ - N), cc.	2	0	-10	0	0	0	10	0	10	0	0	0
	4	0	0	-10	-10	30	10	20	30	20	20	20
	6	10	10	-10	0	10	0	0	10	0	0	10
	8	0	10	10	10	10	10	0	20	0	0	10
Cleavage am- ino nitrogen (NH ₂ -N), mg.	2	20	80	-60	60	20	40	40	40	-20	-60	40
	4	40	-20	-60	40	-60	-60	0	-100	80	-80	-40
	6	20	60	-60	-20	20	120	-80	40	0	0	60
	8	20	-20	40	40	-140	-80	-80	-60	-180	-300	-220

The results of dissolved amino nitrogen are high compared with the cleavage amino nitrogen. This stands to reason, taking into consideration the methods employed. Aluminium cream will precipitate colloidal material, which will not be removed by the centrifugalization method, hence the figures of the latter are higher.

CONCLUSION.

It is evident from the results of this investigation that sodium iodide in concentrations of 0.03 to 2 per cent added to a suspension of liver pulp has no effect on the autolysis of this tissue.

BIBLIOGRAPHY.

1. Kepinow, L., *Biochem. Z.*, 1911, xxxvii, 238.
2. Kaschiwabara, M., *Z. physiol. Chem.*, 1912, lxxxii, 425.
3. Stookey, L. B., *Proc. Soc. Exp. Biol. and Med.*, 1907-08, v, 119.
4. Morse, M., *J. Biol. Chem.*, 1915, xxii, 125.
5. Bradley, H. C., and Morse, M., *J. Biol. Chem.*, 1915, xxi, 209.
6. Plimmer, R. H. A., *Practical organic and bio-chemistry*, London, 1915.
7. Welker, W. H., and Falls, F. H., *J. Biol. Chem.*, 1916, xxv, 567.
8. Preti, L., *Z. physiol. Chem.*, 1909, lx, 317.



I. A CHEMICAL STUDY OF THE BLOOD OF SEVERAL INVERTEBRATE ANIMALS.*

By ROLLIN G. MYERS.

(From the Department of Chemistry and Hopkins Marine Station of Stanford University, Palo Alto.)

(Received for publication, November 17, 1919.)

A study of the literature reveals the existence of comparatively few communications related to this particular field. The earliest work appears to be that of Macallum (1), dealing with the inorganic constituents of the blood of vertebrates and invertebrates. Other investigations somewhat closely related were made by Lipschütz (2), on the metabolism of fishes during starvation; Botazzi (3), on the peritoneal fluid and blood of sea animals; Jona (4), on freezing point values of the blood and body fluids of certain mammals, fish, and crustacea; Okuda (5), dealing with the quantitative determination of creatinine and creatine in some fishes, mollusks, and crustacea; and Fandard and Ranc (6), on sugar in the blood of the sea turtle.

The results embodied in these communications are greatly limited, however. The earlier workers were handicapped by the lack of accurate methods, and hence could not extend their studies to any great length. In later years the only work which has a comparative value when studied with that of the present paper is that of Denis (7), and of Wilson and Adolph (8), dealing with the determination of certain nitrogenous substances in the blood of fresh and salt water fishes; *e.g.*, shark, ray, mackerel, carp, and a few others.

In view of the general lack of information concerning the composition of the blood of invertebrate animals, it is evident that any substantial addition to our knowledge in this field

* This paper is a part of a thesis presented to the Department of Chemistry of Stanford University in partial fulfillment of the requirements for the degree of Doctor of Philosophy.

would be of distinct interest. The immediate object of this investigation was the collection of chemical data along this line, with the added purpose of making a comparative study of the data obtained with relation to that from the more highly evolved animals. It is hoped that this study may bring to light a certain number of general relationships, which will enlarge our ideas of general metabolism, and, more remotely perhaps, assist the zoologist in tracing out some of the less clear biogenetic relationships.

The following invertebrate forms were studied.

Cœlenterates: The jellyfish, *Phacellophora camtschatica*.

Echinoderms: Two species of starfishes, *Pisaster ochraceus* and *Picnropodia helianthoides*. One species of sea urchin, *Strongylocentrotus francescames*.

Mollusks: Two species of clams, *Schizotherus nuttalli* and *Saxidomus nuttalli*. Two species of abalone, *Haliotis rufescens*, and the supposedly primitive molluscan form *Cryptochiton stelleri*.

Crustaceans: Two species of crabs, *Cancer productus* and *Cancer antennarius*. In this case the blood of the two species was mixed.

All the samples of blood were collected from the living animal, (a) by exposing the deeper surfaces, (b) by severing wholly or in part a blood vessel, and (c) by maceration of the tissues.

Where it was possible a specific gravity determination was made, and this was followed by a quantitative and qualitative chemical examination. The quantitative determinations made were total nitrogen, non-protein nitrogen, urea and ammonia nitrogen, amino-acid nitrogen, preformed and total creatinine, uric acid, sugar, cholesterol, chlorides as sodium chloride, calcium as calcium oxide, total solids, and ash. The qualitative tests included the reaction to litmus, the biuret, Millon's, Hopkins-Cole, xanthoproteic tests, and that for loosely combined sulfur.

In general the chemical examination was made directly after the blood was collected. Oxalate or citrate was added only in those cases in which experience had shown that coagulation would occur before the analysis could be undertaken. The samples were kept in tightly stoppered containers which were placed on ice. Toluene was added when conditions made this step advisable. Quantitative determinations were usually run in dupli-

cate, sometimes in triplicate. Analyses were repeated in all cases where there was the least doubt of the accuracy of the results. Relatively complete analyses were made, when the quantity of blood in a given sample permitted this to be done. In several cases repeated analyses of the blood from the same species of animal, collected at different times, were conducted. Whole blood was used in every case, and was composite, from two or nineteen or twenty forms of the same species being represented in the samples analyzed.

The methods followed in the collection of the samples were different for the various species studied. While the jellyfish, *Phacellophora*, possesses no celomic fluid or blood, it was included on account of its zoological position. Consisting largely of amorphous jelly-like mesoglea, quite firm to the touch, it was readily reduced to a fairly homogeneous liquid by gentle maceration through cheese-cloth.

In the case of the starfish, as much as possible of the extraneous sea water was removed, and then several of the rays were clipped off a few centimeters from their distal ends. The exuding liquid was allowed to drain into vessels arranged for the purpose. In the later samples the liquid was filtered through a loose tuft of absorbent cotton.

The procedure was slightly different for the sea urchin. In this case several incisions were made in the membrane surrounding the oral cavity. The animal was drained in the manner previously described, and the liquid filtered as before.

On account of the rather definite circulatory system of the mollusks, the procedure used in the preliminary stages of the work was limited to the selection of some of the larger blood vessels. Later on, however, a quicker and easier method was devised. Rather deep cavities were cut in the foot, for example, of the abalone, *Haliotis rufescens*, or in the gilt-cleft of the *Cryptochiton stelleri*. The blood filled these cavities rapidly and was removed by means of a small pipette with a curved end connected with a suction flask. Or in the case of the abalone, a part of the shell was broken and one of the branchial vessels exposed. This was partially severed, a fairly large hypodermic needle inserted, held securely in place with a small pair of forceps, and the blood carried over into a flask by suction. For

some unknown reason this method did not always yield an abundant supply of blood. A similar method was used for clams. The shell was broken and the position of the heart determined. The pericardial membrane was then severed as well as the superior vena cava and the blood running into the cavity removed in the manner previously described. This, however, is a tedious process. In order to facilitate matters the exposed body of the clam was superficially cut in several places and then gently macerated. The liquid collected was filtered through loose cotton. Total nitrogen determinations made showed a value of 39.98 mg. per 100 cc. of blood obtained in this manner, as compared with 39.92 mg. in blood collected from the pericardial cavity. Thus the difference is slight and the maceration method is to be preferred for simplicity as well as quickness.

The methods used for collecting crab blood were not essentially different from those previously described. Coagulation of the blood of these animals proceeds very rapidly after it is drawn—fibrin frequently separating out before sufficient oxalate is dissolved to prevent it.

Methods of Analysis.

Methods for blood analysis have thus far had a rather narrow application. The protein nitrogen for vertebrate blood has varied in round numbers from 2,800 to 3,700 mg. per 100 cc. of blood. The limits of the mineral constituents perhaps could be truthfully set at 400 to 600 mg. per 100 cc. These values are in decided contrast to those obtained in this investigation from the blood of invertebrate animals. Here the limits for the protein nitrogen vary from 1.5 mg. in the twenty ray starfish to 358 mg. in the crab, and for the mineral constituents from approximately 2,500 to 3,000 mg. per 100 cc. in the various species studied. In fact, comparatively speaking, these numbers are just the reverse in magnitude of those for the common vertebrates. In view of these striking differences, the presumption appears to favor the conclusion that occasional changes in the ordinary analytical procedures would be necessary. Experience in general has justified this view.

For preliminary removal of proteins the 50 per cent solution of trichloroacetic acid, used by Greenwald (9) and others, was by far the most satisfactory precipitant examined.¹ In some instances one precipitation was all that was necessary, the filtrate remaining free from any insoluble matter after considerable concentration. In many cases, however, it was necessary to digest the mixture in boiling water for 15 or 20 minutes to obtain the best effects. Enough of the acid was used to produce a concentration of from 6 to 8 per cent.

The freshly prepared 25 per cent solution of *m*-phosphoric acid recommended by Folin and Denis was not so satisfactory. The filtrates were in general cloudy, and even digestion in boiling water, a procedure which might be questioned, failed to accomplish the end desired. Concentration seemed to be the only recourse. There is, of course, the possibility always present of a union between the acid or some of its derivatives and the protein to form soluble products. This effect is very likely to take place when *m*-phosphoric acid is used, according to Folin and Denis, particularly where the acid is not fresh. Heating would of course favor this condition. Whether trichloroacetic acid would react similarly does not seem to be known, but experience seems to be against such a possibility. In any case any solution of the protein would vitiate the whole procedure.

Picrate-picric acid solution proved a most excellent precipitant, but its special character limited its use.

Alcohol was also used, but evaporation always yielded appreciable quantities of protein.

0.01 *N* acetic acid as a general precipitant was to be criticized in much the same way as *m*-phosphoric acid.

Kaolin as an absorbent of protein was satisfactory.

For total nitrogen, the Kjeldahl-Gunning method was followed, a small quantity of copper sulfate serving as catalyzer.

Non-protein nitrogen was determined by the method of Folin and Denis (10) and also by applying the Kjeldahl method to the protein-free filtrate. On account of the difficulty attendant on the absorption of

¹ The recently described protein precipitant for use in blood analysis, tungstic acid, recommended by Folin and Wu (Folin, O., and Wu, H., *J. Biol. Chem.*, 1919, xxxviii, 81), was not used, since the investigation was nearly completed when the method came to the notice of the author.

color by the silicious insoluble matter, most of the determinations were made by the latter method. In most cases a sufficient supply of blood permitted this choice.

The determination of urea nitrogen was made by the methods of Folin and Denis (11) and Van Slyke and Cullen (12). Latterly the first of these methods was preferred, but with certain modifications. Instead of an emulsion of soy bean, a urease preparation was used either in the form of a powder or of a phosphate solution, according to Van Slyke and Cullen. The blood with the urease was digested at 45-50°C. for 30 minutes or longer, the remaining procedure being similar to that of Folin and Denis, except that 10 cc. of the filtrate were aerated into a known volume of a 0.2 N sulfuric acid solution to which was added ammonium sulfate equivalent to 0.05 mg. of nitrogen per cc., explanation of which will be made later. To expel the ammonia, 15 cc. of saturated potassium carbonate solution were used. The absorbent was then Nesslerized in the usual manner, a 100 cc. volumetric flask being used. The color comparisons were made by a Duboseq colorimeter with the standard set at 20 mm. Control determinations were made by subjecting urea solutions of known concentration to the action of urease, and completing the determination in the same manner as the unknown.

The determination of ammonia nitrogen was made according to the method of Folin and Denis (13) though with considerable modification influenced to some extent by the results of Barnett (14). 10 cc. of the blood were mixed with 15 cc. of saturated potassium carbonate solution and the mixture was aerated into a definite volume of 0.2 N sulfuric acid solution containing 0.05 mg. of ammonium sulfate per cc. The absorbent solution was then Nesslerized according to the method of Folin and Denis, and a colorimetric determination made with the standard set at 20 mm. Since a definite quantity of ammonia nitrogen was used to start with in the absorbent, this was subtracted from the total. The remainder represented the ammonia nitrogen in the blood. As will be noted a similar procedure was used in the determination of urea. The advantages of aerating into a standard solution of ammonium sulfate made acid with sulfuric acid are easily seen in this determination. The accessory apparatus of polarimeter tubes and condenser is eliminated. The depth of shade of the Nessler solution can be varied to suit the eye. Finally Nesslerizations can be made in 100 cc. volumetric flasks and after a little practice the standard can be so adjusted to the unknown that the reading will vary not more than 4 or 5 mm. from 20. The same remarks may well apply for the determination of urea nitrogen. The gain in simplicity is considerable.

In general the author does not look on aeration procedures with any great degree of favor. In spite of protective tubes and capacious aeration cylinders, it was necessary occasionally to make repeated determinations. The distillation procedure is perhaps more preferable.

The observation made by Barnett (14) that the quantity of ammonia nitrogen increases in the blood on standing was followed in its practical

significance by conducting the determination as soon as possible after the blood was drawn. That there is a decided increase in the quantity of ammonia on standing is in general agreement with the author's findings. This, it might be mentioned, is particularly true for whale blood.

Amino-acid nitrogen was determined by means of the Van Slyke (15) micro apparatus. In the initial treatment of the sample, the procedure of Bock (16) was followed. Several determinations were made, but only two are given in the table. In sea urchin, abalone, and crab blood values varying from 30 to 70 mg. per 100 cc. were obtained. The determinations were not always made directly after the blood was drawn. The post-mortem formation of amino compounds, or the action of certain substances in the blood on the nitrite used, might account for these high values. In any case there appear to be certain disturbing conditions.

Preformed and total creatinine were determined according to the method of Denis (17). In some cases 10 cc. of the standard were added to the unknown, and the determination was made. The picric acid used was tested according to the method of Folin and Doisy (18) and was found to satisfy the requirements. The principal difficulty experienced was the failure of color to develop after the prescribed amount of 10 per cent sodium hydroxide was added. Precipitates usually formed after the base was added. In order to overcome the first of these difficulties a cautious addition in excess of from 0.5 to 1 cc. of the base was made. Within narrow limits a variation in the base used had no influence on the reading when the experiment was conducted on standard creatinine solutions of the same concentrations. Precipitates were eliminated by centrifugalization. These difficulties appeared to be accentuated in determinations of total creatinine.

Uric acid was determined by the method of Folin and Denis (19). For amounts of uric acid which are found in human blood or of an approximate magnitude, no trouble was experienced. When only traces of the acid exist, and these in the presence of about 3 per cent sodium chloride, difficulties were encountered which were not entirely overcome. In order to render measurable the traces which appeared to be unmistakably present, from 30 to 50 cc. of the blood were used. The crystallizing out of considerable quantities of sodium chloride on evaporation appeared to vitiate the determination. Definite quantities of uric acid were then added to 3 per cent sodium chloride solution, but it seemed to be impossible to recover anything like the quantity of acid added. The large excess of sodium chloride may hinder perhaps the formation of silver urate by its mass action effect. Indications are that the method must be considerably modified to determine small quantities of uric acid under the conditions described.

Sugar was determined by the method of Lewis and Benedict (20). The picramic acid for the standard was prepared² according to the later method

² The work of preparation was kindly performed for the author by Dr. E. Oertly of Stanford University.

of Egerer (21). The only difficulty met with was in the application of the method to certain samples of blood such as that of the starfish, where the protein was very low. In this case the precipitate formed was difficult to remove by filtration. The precipitate appeared in the form of a suspension which did not readily settle.

For cholesterol, the method of Myers and Wardell (22) was used. Two modifications were introduced after several experiments. Instead of the standard "naphthol green B," a standard solution of Kahlbaum's cholesterol 1.0 mg. per 100 cc. in chloroform was used. The original procedure of taking an aliquot part of the extract was changed and the whole volume was concentrated to 5 cc. This modification was made necessary on account of the small quantities of cholesterol present, even when 3 to 5 cc. of the original blood were used.

It was found that the unknown as well as the standard cholesterol solutions possessed a decided bluish tint after performing the Liebermann-Burchard reaction. Hence good comparisons could not be made with the dye used as a standard. The blue shade observed is in decided disagreement with the observations made by Luden (23) in connection with the same reaction.

A final difficulty, not fully overcome, was the formation of a reddish shade in the extracts. This increased after adding the sulfuric acid and acetic anhydride. The shade seemed to develop to the greatest extent in clam blood. In the light of Luden's work the conclusion may be drawn that this color is due to icteric substances in the blood. At any rate, the color comparisons were made most difficult on account of this condition.

Chlorides as sodium chloride were determined according to the method of Rappleye (24). The method is simple and the end-point sharp for the chlorides in most invertebrate blood. When the sodium chloride is less than 0.6 per cent, the end-point becomes somewhat uncertain. Only 1 cc. of blood was used for the determinations, the amount of the silver nitrate solution varying from 15 to 20 cc. These quantities are slightly different from those prescribed by the method. In the author's view the method is considerably more simple than that of Van Slyke and McLean, and equally as accurate.

For total solids, ash, and calcium as the oxide, 5 to 10 cc. of the blood were evaporated to dryness in a weighed porcelain crucible over a water bath, and the residue was dried to constant weight at 110-115°C. This represented the total solids. The residue was then ignited, the temperature being kept as low as possible to avoid volatilization of the alkalis—a condition not always easy to accomplish in removing the last trace of the carbon—and then weighed. This represented the ash. The latter was then extracted with 15 to 20 cc. of concentrated hydrochloric acid, and the calcium as the oxide determined in general according to the method of McCrudden (25).

Specific gravity determinations were made at 20°C. by a pycnometer bottle.

The values in Table I exhibit several differences when compared with similar determinations made on the more highly developed animals. The exceptionally high content of inorganic salts, 2,900 to 3,200 mg., and the low protein nitrogen content, 0.7 to 340 mg. per 100 cc. of the blood, may be taken in illustration.

The influence of high saline content on osmotic pressure is obvious. The relatively small amount of urea and other organic crystalloids in the samples of blood examined clearly proves that the osmotic pressure is for the most part caused by the inorganic constituents. In any case the osmotic pressure is nearly the same as sea water ($\Delta = 1.81-2.8^\circ$) (26). In the more highly developed elasmobranch fishes this pressure is undoubtedly produced to a notable degree by the very large quantities of urea present in the blood, a constituent present in only small quantities in invertebrate blood. Neither the invertebrates examined nor the elasmobranch fishes appear to be independent of the surrounding medium in this regard. Neither set of forms has any means which enable them to influence their own osmotic pressure. This is in direct contrast to the marine and fresh water teleost fishes where probably a reduced saline as well as a urea content effects a material lowering of the osmotic pressure of $\Delta = 0.7^\circ$. As pointed out by Wilson and Adolph (27), these species are partially independent of changes in the surrounding medium. Undoubtedly the gills of these fishes have been modified in some way which enables them to adapt themselves to conditions of this kind.

That the low protein content of the blood of the invertebrate animals has a decided influence on its viscosity can hardly be doubted. Compared with the viscosity of the more highly developed marine forms and the mammals it should be considerably lower. In mollusk and crustacean blood the increased protein content would be parallel to an increased viscosity, and this in turn is associated with an improved cardiac and circulatory apparatus.

The buffer effects of the protein in mammalian blood in maintaining the required hydrogen ion concentration probably prevail in the blood of invertebrates, this value approximately being from 6.4 to 6.7 pH if the alkaline reaction to litmus is considered (Table II).

TABLE I.
Quantitative Data per 100 Cc. of Blood.*

Animal.	Specific gravity.	Solids.	Ash.	Ca as CaO.	Cl as NaCl.	Total N.	Non-protein N.	Urea + NH ₃ N.	Urea.	NH ₃ N.	NH ₃ amino N.	Creatinine.		Uric acid.	Sugar.	Cholesterol.	Remarks.	
												Performed.	Total.					
		mg.	mg.	mg.	mg.	mg.	mg.	mg.	mg.	mg.	mg.	mg.	mg.	mg.	mg.	mg.		
Jellyfish, <i>Phacelophora camtschatica</i> .						44	12	5.0				0.01	0.30	0.29	109		Obtained from Monterey Bay, Cal.	
5 ray starfish, <i>Pisaster ochraceus</i> .				53	3,225	5	4.4	1.0	0			0.01	0.13	0.12		0.9	Obtained from Monterey Bay, Cal.	
20 ray starfish, <i>Picnopodia helianthoides</i> .				56	3,225	6	4.0	2.0							29	1.0	Obtained from Monterey Bay, Cal.	
Sea urchin, <i>Stron-glyocentrotus franciscanus</i> .	1.024	3,485	2,992	63	3,140	12	8.6	1.0	0.92	0.08		0.11	0.27	0.16	Trace.	61	4.0	Obtained from Monterey Bay, Cal.
Clam, <i>Saxidomus nuttalli</i> .		4,330	2,800	307		44	11.0					0.28			50		Obtained from Moss Landing, Cal.	
						59	13.0	10.0	9.05	0.95		0.31	0.74	0.43	77			
<i>Schizothorus nuttalli</i> .	1.029	4,208	3,290	193	3,190	40	14.0	3.6	2.94	0.66	8.0	0.38	0.80	0.42	Trace.	74	2.0	Obtained from Moss Landing, Cal.

TABLE II.
Qualitative Data on Samples of Whole Blood.

Animal.	Color of blood.	Litmus.	Reaction.				
			Xanthoproteic.	Millon.	Hopkins-Cole.	Lead.	Buret.
Jellyfish, <i>Phacelophora cam-</i> <i>tschatici</i>	Colorless, macerate.	Slightly alkaline.	Medium.	Medium.	Quite strong.	Weak.	Medium.
<i>Cryptochiton stelleri</i>	Dark am- ber.	"	Medium.	Medium.	Weak.	Weak.	Medium.
Sea urchin, <i>Strongylocentrotus</i> , <i>francescames</i>	Orange.	"	Medium.	Medium.	Weak.	Weak.	Medium.
Abalone, <i>Haliotis rufescens</i>	Light in- digo blue.	"	Quite strong.	Quite strong.	Strong.	Very strong.	Pinkish.
Clam, <i>Schizothorus natali</i> .	Bluish tint.	"	Medium.	Medium.	Weak.	Quite strong.	Medium.
Crab, <i>Cancer productus</i> and <i>antennarius</i>	Light greenish blue.	"	Strong.	Quite strong.	Very strong.	Strong.	Pinkish.

The high values for calcium oxide, from 53 to 307 mg. per 100 cc. of blood are in accord with what one might expect in view of the considerable demand on the part of the invertebrate animals for the calcareous matter needed for the shell. The largest amount, 307 mg. per 100 cc. of blood, occurs in the *Saxidomus* clam. The shell of this species is much heavier than that of the associated *Schizotherus* clam. But if this criterion is taken to account for the difference in the amount of the calcium salts observed, it is somewhat difficult to account for the lower values 74 to 87 mg. per 100 cc. in abalone blood. A qualitative observation favors the view, however, that the proportion of the body of the clam to its shell is considerably less than in the case of the abalone.

Compared to several mammals, *e.g.* human blood 9.5 to 11 mg. per 100 cc., the calcium salts found in invertebrate blood may be several times as great.

The proportion of urea nitrogen to non-protein nitrogen appears to vary within rather wide limits. This is true for the echinoderms, 22 to 62 per cent of the non-protein nitrogen being represented as urea nitrogen in the blood of starfishes and 11 per cent in the one sample of sea urchin blood examined. In the mollusks and the one sample of crustacean blood the amounts vary from 7 to 70 per cent, though the mean value would fall more nearly between 10 and 20 per cent. The tendency then seems to be toward conditions similar to those which prevail in the blood of the teleost and ganoid fishes. The additional fact that the urea nitrogen is 40 per cent of the non-protein nitrogen in the flesh of the jellyfish examined has further interest.

The partition of the urea nitrogen between the form elements and the plasma was not studied. The form elements, however, comprise only a small proportion of the total nitrogen of the blood, it is believed. This appeared to be true particularly in the case of *Schizotherus* clam blood. The indications are that the urea is found principally in the plasma.

The ammonia, preformed creatinine, and total creatinine content of the blood of the echinoderms, mollusks, and crustaceans examined was in general considerably lower than the same constituents observed in the elasmobranch, teleost, and ganoid fishes (28). The amount of ammonia seemed to approximate more

closely that found in mammalian blood, though the creatinine and creatine are still lower even in this case. In addition to this the amount of creatine found in invertebrate blood was only a little greater frequently than the preformed creatinine. In starfish blood the creatine appears to be greatly in excess of the preformed creatinine, however.

The occurrence, at most only in minute traces, of uric acid in the blood of most of these animals agrees with the findings of Denis, in respect to the blood of the elasmobranch fishes. In the blood of the crab the amount of uric acid is relatively high, 4.7 mg. per 100 cc., and considerably in excess of that found in human blood; *e.g.*, 0.7 to 3.7 mg. per 100 cc. In this regard the metabolism of the crab appears to be similar to that of the birds and reptiles.

The amino-acid nitrogen probably makes up a large part of the remainder of the non-protein nitrogen, though only two determinations can be given to support this statement.

Sugar was found in all the samples of invertebrate blood examined, and varies from 29 to 90 mg. per 100 cc. of the blood. These values are similar in magnitude to those of human blood, *e.g.* 20 to 150, and perhaps other mammals. The only other determinations of sugar made on invertebrates were those of Fandard and Ranc (29) in the blood of a fasting turtle. Their values range from 82 to 95 mg. per 100 cc. of the blood, which are in agreement with those of the author for abalone and crab blood. The extreme variation does not appear to be wide in any of the animals examined. In respect to the invertebrate blood, it is interesting to speculate on the manner in which these animals maintain the amounts of sugar observed, in the presence of so much sodium chloride. At least in man the injection of 1 per cent salt solution intravenously becomes a glycretic in causing a decided increase of the blood sugar in the urine. The relatively large amounts of calcium salts in the blood of invertebrates may lessen the permeability of the excretory membranes as they do apparently in man (30).

The quantity of cholesterol found was small in all the bloods examined, the variation extending from about 1 to 6 mg. per 100 cc. of blood. Compared with the values given for human blood (30 to 60 mg. per 100 cc.) they appear to be very low.

There seems to be considerable scarcity of data for cholesterol in the blood of mammals as well as of fishes. Hence any comparison must be extremely limited.

Finally it is of extreme interest to note the occurrence of several of the combined amino-acids, *e.g.* tyrosine, tryptophane, and cystine, in the tissue and the blood of these marine forms (Table II). If the qualitative tests are significant, the relatively large amounts of combined cystine and tryptophane in abalone and crab blood are most interesting.

SUMMARY.

The following determinations were made on the blood of several invertebrate animals: Specific gravity, total solids, calcium as calcium oxide, chlorine as sodium chloride, total nitrogen, non-protein, urea, ammonia, and amino-acid nitrogen, preformed and total creatinine, uric acid, sugar, and cholesterol. These values are found in Table I.

The osmotic pressure of the blood of these animals is about the same as sea water, and in this respect they agree with the elasmobranch fishes; *e.g.*, shark and ray. The major part of the osmotic pressure is due to the high saline content and not to the urea as in the elasmobranch fishes.

The very possible influence of low protein content in the blood on the lowered viscosity and the probable increase of this factor in the blood of the Mollusca and Crustacea is accompanied by a more highly developed circulatory system.

The urea content is relatively low, though the mean value is higher than that observed in some of the marine and fresh water fishes.

The ammonia, preformed creatinine, and creatine were generally lower than in the blood of the vertebrate fishes and other mammals.

The amino-acid nitrogen probably makes up the larger part of the non-protein nitrogen.

Sugar was found in the blood of every invertebrate examined and in relatively large quantities. In comparison with the sugar in the blood of other forms, the differences were not great.

Cholesterol was found in very small quantities. In comparison with the blood of man, the amounts were low.

The combined amino-acids, tyrosine, cystine, and tryptophane, the two latter in considerable quantities, were shown to be present in most of the blood(s), and in one case the tissue, of the invertebrate animals examined.

In conclusion the author wishes to express his great indebtedness to Professor R. E. Swain, whose many suggestions and practical assistance had a most happy influence on the success of this investigation as well as that connected with whale blood reported in the following paper.

In connection with the collection of the blood samples, the author wishes to acknowledge also the invaluable assistance of Professor Walter K. Fisher of the Hopkins Marine Station of Stanford University, Monterey, California.

BIBLIOGRAPHY.

1. Macallum, A. B., *Proc. Roy. Soc. London, Series B*, 1909-10, lxxxii, 602.
2. Lipschütz, A., *Z. allg. Physiol.*, 1911, xii, 118.
3. Botazzi, F., *Z. Chem. Ind. Kolloid*, 1911, v, 36.
4. Jona, J. L., *Biochem. J.*, 1912, vi, 130.
5. Okuda, Y., *Orig. Com. 8th Internat. Cong. Appl. Chem.*, 1912, xviii, 275-281.
6. Fandard, L., and Ranc, A., *Compt. rend. Soc. biol.*, 1913, lxxiii, 437.
7. Denis, W., *J. Biol. Chem.*, 1913-14, xvi, 389.
8. Wilson, D. W., and Adolph, E. F., *J. Biol. Chem.*, 1917, xxix, 405.
9. Greenwald, I., *J. Biol. Chem.*, 1918, xxxiv, 97.
10. Folin, O., and Denis, W., *J. Biol. Chem.*, 1916, xxvi, 491.
11. Folin, O., and Denis, W., *J. Biol. Chem.*, 1916, xxvi, 505.
12. Van Slyke, D. D., and Cullen, G. E., *J. Biol. Chem.*, 1914, xix, 211.
13. Folin, O., and Denis, W., *J. Biol. Chem.*, 1912, xi, 532.
14. Barnett, G. D., *J. Biol. Chem.*, 1917, xxix, 459.
15. Van Slyke, D. D., *J. Biol. Chem.*, 1913-14, xvi, 121.
16. Bock, J. C., *J. Biol. Chem.*, 1917, xxix, 191.
17. Denis, W., *J. Biol. Chem.*, 1918, xxxv, 513.
18. Folin, O., and Doisy, E. A., *J. Biol. Chem.*, 1916-17, xxviii, 349.
19. Folin, O., and Denis, W., *J. Biol. Chem.*, 1912-13, xiii, 469.
20. Lewis, R. C., and Benedict, S. R., *J. Biol. Chem.*, 1915, xx, 61.
Benedict, S. R., *J. Biol. Chem.*, 1918, xxiv, 203.
21. Egerer, G., *J. Biol. Chem.*, 1918, xxxv, 565.
22. Myers, V. C., and Wardell, E. L., *J. Biol. Chem.*, 1918, xxxvi, 147.
23. Luden, G., *J. Biol. Chem.*, 1917, xxix, 463.
24. Rappleye, W. C., *J. Biol. Chem.*, 1918, xxxv, 509.

25. McCrudden, F. H., *J. Biol. Chem.*, 1909-10, vii, 83.
26. Garrey, W. E., *Biol. Bull.*, 1915, xxviii, 77. Botazzi, F., *Ergebn. Physiol.*, 1908, vii, 161.
27. Wilson, D. W., and Adolph, E. F., *J. Biol. Chem.*, 1917, xxix, 405.
28. Denis, W., *J. Biol. Chem.*, 1913-14, xvi, 390. Wilson, D. W., and Adolph, E. F., *J. Biol. Chem.*, 1917, xxix, 405.
29. Fandard, L., and Ranc, A., *Compt. rend. Soc. biol.*, 1912, lxxiii, 437.
30. Fischer, M. H., *Univ. California Publications, Physiology*, 1902-04, i, 77, 87.

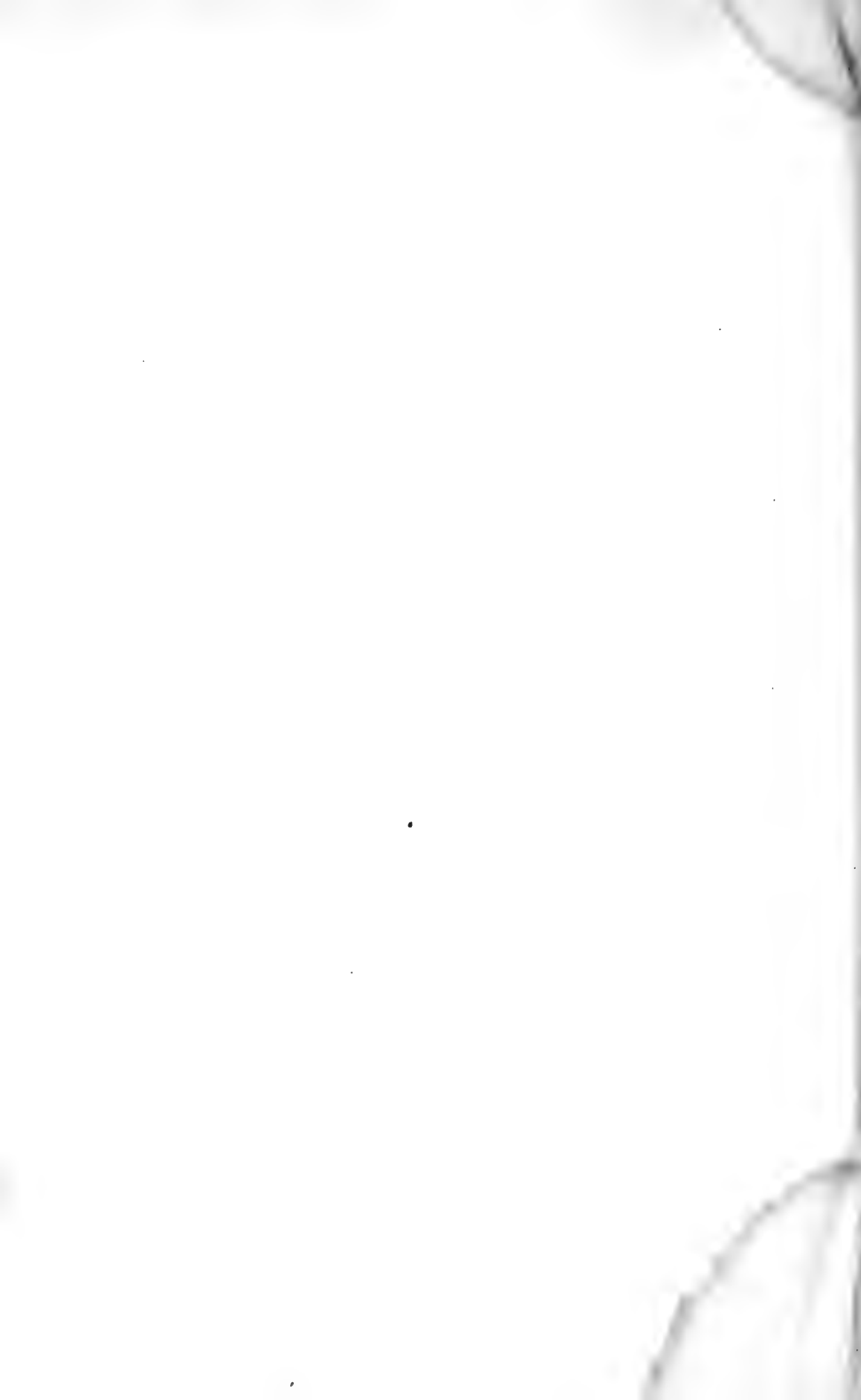

II. A CHEMICAL STUDY OF WHALE BLOOD.*

By ROLLIN G. MYERS.

(From the Department of Chemistry and Hopkins Marine Station of Stanford University, Palo Alto.)

(Received for publication, November 17, 1919.)

A study of the literature revealed an almost complete lack of any work done in connection with the chemistry of whale blood. There seems, indeed, to be a general lack of information in respect to the zoological side as well. This paper then becomes an entirely new addition to the chemical knowledge of the whale, in particular to that of its blood. While not extensive, as far as repeated analyses are concerned, the work at least is a beginning for more extended examinations.

Two species only are included; the humpback whale *Megaptera versabilis* Cope, and the sperm-whale *Physeter macrocephalus* Linneus.

It was impossible to obtain the blood directly after the animal was killed. 3 or 4 hours, sometimes more, frequently elapsed before the sample was obtained. The blood was obtained from the freshly exposed and deeper muscular regions of the animal. The blood gushed from these regions in large quantities and no difficulty was experienced in getting it. It was quite warm and clotting ensued only some time after it was drawn. The ordinary methods failed to recover any fibrin from the blood of the humpback whale. The amount obtained from sperm-whale blood was relatively small compared to the blood used. Oxalate was added, except in samples where total solid determinations were made. The first humpback whale sample was taken from the thoracic cavity. The blood is probably not very pure, but it was decided to include it in the tabulation.

* This paper is part of a thesis presented to the Department of Chemistry of Stanford University in partial fulfillment of the requirements for the degree of Doctor of Philosophy.

TABLE I.
 Analyses per 100 Cc. of Whale Blood.

Animal.	Date.	Specific gravity.	Total solids.	Ca as CaO.	Cl as NaCl.	Total N.	Non-protein N.	Urea + NH ₃ N.	Urea.	NH ₃ N.	NH ₃ -acid N.	Creatinine.		Uric acid.	Sugar.	Cholesterol.	Remarks.
												Performed.	Total.				
Humpback whale, <i>Megaptera terrae</i> <i>versabilis</i> Cope. 1*	1919																Killed in Monterey Bay, Cal.
	Mar. 24					1,177	325	160	156	4.0		2.2		400			
Sperm-whale, <i>Physeter mac- rocephalus</i> Linnaeus. †	"	1.038		15.8	580	2,237	221	137	122.5	14.5	59	17.6	39.2	65.1	266	12.6	Killed in Monterey, Bay, Cal.
	May 1	1.061	22,025	13.7	509	3,518	116	74	71.6	2.4	31	5.3	14.2	8.9	2.1	118	

* The blood was probably impure, since it was selected from drainings into the thoracic cavity.

† This animal was about 40 feet long and had an estimated weight of 35 tons. This species belongs to the whale bone whales. A larger species is the so called "sulfur bottom" or baline whale. The latter grow to the length of 95 feet. The humpback feeds on large quantities of sardines and anchovies. Their stomachs have been known to contain from 2 to 3 tons of these fish.

‡ The specimen from which the blood was obtained had a length of 65 feet 9 inches. The lower jaw was about 8 to 9 feet in length, and had 48 teeth 2 to 3 inches in diameter, and was narrow and tapering. The head was about one-third the length of the whole body. The weight of the animal was variously estimated at from 80 to 90 tons. Blubber was 6 to 8 inches in thickness. Of the spermaceti recovered, there were 90 barrels from the whole animal, 32 barrels coming from the head alone. The exposed intestines had a dark, though bright fluorescent green color. The stomach contained a shark 10 feet 2 inches long, the pigmented layer of whose skin only having been attacked by the gastric juices, the skin of a partially digested seal, and 8 feet of fishing line with six hooks. While the flesh of the humpback whale is used for food, the flesh of this species is not. The sperm-whale appears to be entirely carnivorous in habits, squid and devil fish being favored articles of diet. When wounded it will attack the pursuing boat, according to reports. The author was favored with most of the above data by Mr. Chester I. Dennis, an official of the California Sea Products Company, Moss Landing, Cal.

The methods of analysis employed were the same as those used in the examination of invertebrate blood (see page 122). Little if any difficulty was experienced in the application of these methods.

In contrast to invertebrate blood, *m*-phosphoric acid solution gave clear filtrates. These, however, precipitated small quantities of protein on evaporation.

In the cholesterol determinations the reddish shade noted in the previous paper was also present in the extracts of whale blood.

A study of Table I reveals noteworthy differences in the composition of humpback and sperm-whale blood. Not only are these differences exhibited in the protein content, and in the nitrogen partition, but in some of the other constituents as well. Our general ignorance of the habits and life of these animals renders somewhat abortive all attempts to account satisfactorily for these differences. Both animals appear to be carnivoral feeders, though the sperm-whale, in contrast with the humpback, devours larger animals. Many other conditions would have to be considered, however, and the whole question will remain obscure until our knowledge becomes more definite and extended.

In respect to the humpback whale the large quantity of urea in the non-protein fraction would have a considerable influence on the osmotic pressure of the blood. This would be considerably lower than that of sea water, of invertebrate and elasmobranch fish blood, though higher than that of the marine and fresh water teleost fishes. The value $\Delta = 0.8 - 0.9^\circ$, would perhaps be an approximation. The blood of the sperm-whale is considerably lower than this, the range of this value being similar in magnitude to that of the teleost fishes ($\Delta = 0.7^\circ$). The osmotic pressure of the blood of both species however is higher than that of the blood of several of the land mammals; *e.g.*, $\Delta = 0.6^\circ$. Evidently both species are relatively independent of changes in the medium, which would give them a wide foraging capacity. It is somewhat interesting in this connection to speculate on the ability of the whale to adapt itself to a fresh water medium.

The striking contrast in the amounts of protein in the blood of the humpback (13,981 mg.) and the sperm-whale (20,775 mg.

per 100 cc.) suggests interesting possibilities. From one point of view the increased viscosity of sperm-whale blood might call for changes in the circulatory apparatus over that of the humpback whale. From another point of view the decreased buffer property of the protein in the latter species would lower its power over the former in absorbing acids or bases during metabolism. It is conceivable that this point could have considerable significance in relation to special conditions tending to disturb the hydrogen ion concentration of the blood, the sperm-whale being considerably favored in this regard over the other species. In respect to human blood, at least, the protein of the blood of the sperm-whale is practically the same in quantity. As can be seen this does not hold true for the humpback.

The percentage of urea nitrogen in the non-protein content is much the same for both animals. In sperm-whale blood it is slightly over 60 per cent and in humpback whale blood 48 per cent. These are high values for mammals. They are also in excess of those for the blood of invertebrates, as well as for the marine and fresh water teleost and ganoid fishes, the blood of only the elasmobranch fishes exhibiting a greater percentage.

The quantity of the amino-acid nitrogen is also greater than that found in land mammals (1). In addition to this it makes up the larger part of non-protein nitrogen after subtracting the urea nitrogen.

The creatinine and creatine content is also relatively high for mammals.

The amount of uric acid found was not so excessive though its range more closely approximates that present in birds and reptiles.

The amount of the inorganic constituents does not differ greatly from that observed in human blood and other mammals. The effect of these substances on the osmotic pressure is very slight in comparison with that in the blood of the invertebrate animals.

The total solids and the specific gravity appear to vary considerably from human blood (specific gravity 1.026 to 1.030; solids 21,000 to 24,000 mg. per 100 cc.). The specific gravity of sperm-whale blood is much higher, though the solids are of a mean value.

The large amount of sugar in humpback whale blood appears to be rather excessive compared with human blood; that of the

sperm-whale, however, is much the same as that found in the latter. In both species it is much higher than that observed in the blood of invertebrates.

The cholesterol values obtained in the blood of both species are within the range found in human blood (30 to 60 mg. per 100 cc.), though very high compared to the amounts found in the blood of invertebrates.

The composition of whale blood seems to show several anomalies to that of other animals. Doubtless the peculiar habits of this animal and the fact that it is a marine mammal may help to account for these differences.

Further it is interesting to speculate on the special character of a metabolism which not only elaborates larger quantities of fat but the wax, spermaceti (cetyl palmitate), as well. Such phenomena only serve to make more impressive the marvelous lability of the chemical processes involved in the general metabolism of animal life.

SUMMARY.

Analyses of the blood of the humpback and sperm-whale were made. These analyses include the determination of specific gravity, solids, calcium as calcium oxide, chlorine as sodium chloride, total nitrogen, non-protein, urea, and ammonia nitrogen, creatinine and creatine, amino-acid nitrogen, uric acid, sugar, and cholesterol. These data are to be found in Table I.

The osmotic pressure of the blood of both species is undoubtedly higher than in other mammals ($\Delta = 0.7-0.9^\circ$ approximately) but lower than that of the elasmobranch fishes and the invertebrates.

A considerable variation exists in the quantity of protein in the blood of the two species. In the sperm-whale it is nearly the same as that in human blood (21,000 mg. per 100 cc.). In the other species it is less than two-thirds as great.

The urea content is high for mammals, as well as the percentage of urea nitrogen in the non-protein fraction. Nor are the invertebrates or some fishes excepted in this respect, though the content of urea in the blood of the elasmobranchs exceeds that of whale blood.

The content of amino-acid nitrogen, of ammonia nitrogen, and of creatinine and creatine is generally higher in whale blood than in the other mammals, some marine invertebrates, and fish.

The uric acid content was not found to be excessive. It would probably range rather closely to that of birds and reptiles.

In respect to the amounts of the sugar and cholesterol, the former appeared to be excessive in the blood of only the hump-back whale, though in the blood of the other species the amount found was similar to that found in human blood. The amounts of cholesterol in the blood of both species had much the same range of magnitude as is observed in human blood.

The amount of the mineral constituents was much the same as in other mammalian blood.

The specific gravity of sperm-whale blood is much higher than that of human blood, and for the other species it closely approximates the latter.

BIBLIOGRAPHY.

1. Bock, J. C., *J. Biol. Chem.*, 1917, xxix, 191.



NOTE ON THE PREPARATION OF *p*-DIMETHYLAMINO- BENZALDEHYDE.

BY T. INGVALDSEN AND L. BAUMAN.

(From the Department of Internal Medicine, State University of Iowa, Iowa City.)

(Received for publication, December 12, 1919.)

During the war there was a shortage of *p*-dimethylaminobenzaldehyde. This compound is the chief ingredient of Ehrlich's reagent which is used for the determination of urobilinogen in the urine, feces, and bile. As there appeared to be a demand for this substance by physicians and investigators it was desirable to attempt to simplify the method of preparation. Several methods are to be found in the literature. The method of Ullmann and Frey¹ appeared simple and easy of execution. It consists of the following steps: (a) The preparation of *p*-nitrosodimethylaniline; (b) the reaction of (a) with *p*-dimethylaminobenzyl alcohol; (c) the cleavage of anhydro-*p*-dimethylaminobenzaldehyde-*p*-aminodimethylaniline and liberation of the desired aldehyde.

The reaction involved in step (b) is as follows.

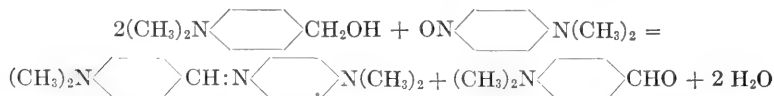

As an excess of the nitroso body is used, the second molecule of aldehyde is partially converted into the benzylidene body.

Experience has led us to modify the procedure in several respects. The isolation of the hydrochloride of the benzylidene compound is omitted. The decomposition of the free base by formaldehyde and acetic acid is carried out at room temperature. The crude aldehyde is purified by distillation in a partial vacuum.

¹ Ullmann, F., and Frey, B., *Ber. chem. Ges.*, 1904; xxxvii, 855.

Preparation of p-Dimethylaminobenzaldehyde.

300 gm. of technical dimethylaniline are dissolved in 1,500 cc. of dilute hydrochloric acid (1:1) and placed in a freezing mixture. A saturated solution of 180 gm. of sodium nitrite in water is added slowly from a dropping funnel while the reaction mixture is being agitated by a mechanical stirrer. The operation requires about 1 hour. The nitroso body is filtered with suction and washed with the dilute hydrochloric acid. In the meantime 360 gm. of dimethylaniline, 250 cc. of formaldehyde, and 600 cc. of concentrated hydrochloric acid are mixed in a large beaker which is heated on the boiling water bath for about 10 minutes after which the nitroso compound is added at once. The violent reaction which ensues is completed in about 5 minutes. After cooling and diluting with water, the base is precipitated by the addition of commercial sodium hydroxide (lye) until all the red color has disappeared. The solid is removed by filtration and washed with tap water.

The moist base is transferred to a heavy beaker and covered with 2,000 cc. of 50 per cent acetic acid and 500 cc. of commercial formaldehyde. The mixture is stirred until 20 minutes after the benzylidene compound has gone into solution. The aldehyde separates as a crystalline mass after adding 1,000 cc. of water and crushed ice. After 12 hours refrigeration the solid is filtered off and washed until the washings are perfectly clear. It is dried at room temperature. Yield 260 gm.

Purification is carried out by distillation of the *dry* aldehyde from an oil bath. At 43 mm. pressure it distills at 200°. The hot distillate is treated with 200 cc. of 95 per cent alcohol, poured into a large mortar, and stirred while distilled water is gradually added. All large lumps must be broken up with the pestle. The product is then transferred to a large beaker containing 1,000 cc. of water and 25 cc. of glacial acetic acid. Yield 250 gm. of pure product melting at 73°C. The approximate cost is about 5 cents per gm.

NOTE ON THE OXIDATION OF SUGARS BY MERCURIC ACETATE IN THE PRESENCE OF AMMONIA.

BY T. INGVALDSEN AND L. BAUMAN.

(From the Department of Internal Medicine, State University of Iowa, Iowa City.)

(Received for publication, December 12, 1919.)

In the past a number of investigators have studied the oxidation of sugars by mercuric salts with the object of obtaining a method for their qualitative or quantitative determination. Herzfeld¹ found that glucose is readily oxidized by red mercuric oxide in the presence of barium hydroxide. Heffter² obtained gluconic acid by boiling a glucose solution with yellow mercuric oxide.

Ammonium gluconate and ammonium galactonate may be obtained in a 50 per cent yield by the action of mercuric acetate on glucose or galactose in the presence of ammonia. Mannose and lactose are also oxidized by this method but the ammonium salts of their respective acids cannot be isolated in crystalline form.

Preparation of Ammonium Gluconate and Galactonate.

10 gm. of glucose dissolved in 100 cc. of water are treated with 25 gm. of mercuric acetate and 15 cc. of concentrated ammonia solution and allowed to remain at room temperature over night. The solution is then placed on the water bath for 12 hours, saturated with hydrogen sulfide, filtered, purified with bone-black, and evaporated in a partial vacuum. Ammonium gluconate crystallizes when the remaining syrup is treated with alcohol. The crystals occur as thin hexagonal plates and melt at 155–157° (uncorrected). The physical constants are similar to those obtained by Irvine, Thomson, and Garrett³ and also to those of a

¹ Herzfeld, A., *Ann. Chem.*, 1888, ccxlv, 27.

² Heffter, A., *Ber. chem. Ges.*, 1889, xxii, 1049.

³ Irvine, J. C., Thomson, R. F., and Garrett, C. S., *J. Chem. Soc.*, 1913, ciii, 238.

148 Oxidation of Sugars by Mercuric Acetate

sample of ammonium gluconate obtained by the oxidation of glucose with bromine. The yield is 6 gm. from 10 gm. of glucose. The recrystallized substance analyzed as follows.

0.4156 gm. required 19.5 cc. of 0.1 N sulfuric acid (Kjeldahl).
Calculated for $C_6H_{15}O_7N$ 6.57 per cent. Found 6.56 per cent.
The specific rotation was $+13.63^\circ$.

$$[\alpha]_D^{20} = \frac{6.3192 \times +3.21^\circ}{1.3642 \times 1.0908}$$

Ammonium galactonate when prepared by the above method crystallizes in small needles. The yield is 7 gm. from 10 gm. of galactose. The melting point is $155-157^\circ$.

The recrystallized sample analyzed as follows.

0.3388 gm. required 15.9 cc. of 0.1 sulfuric acid (Kjeldahl).
Calculated for $C_6H_{14}O_7N$ 6.56 per cent of nitrogen. Found 6.57 per cent.

The specific rotation was $+3.33^\circ$.

$$[\alpha]_D^{20} = \frac{6.3116 \times +0.75^\circ}{1.2986 \times 1.0946}$$

FAT-SOLUBLE VITAMINE.*

IV. THE FAT-SOLUBLE VITAMINE CONTENT OF GREEN PLANT TISSUES TOGETHER WITH SOME OBSERVATIONS ON THEIR WATER-SOLUBLE VITAMINE CONTENT.

BY H. STEENBOCK AND E. G. GROSS.

WITH THE COOPERATION OF MARIANA T. SELL.

(From the Laboratory of Agricultural Chemistry, University of Wisconsin, Madison.)

(Received for publication, December 6, 1919.)

While the mere isolation and the determination of properties of substances found in the plant and animal kingdom are most fascinating and stimulating procedures in the chemical laboratory, such work becomes especially engaging from the biochemical point of view, when speculation as to the rôle of the multitudinous array of compounds is injected into the work. Viewed from this angle, there is little wonder that the attention of many biochemists should, at devious times, have been absorbed in the work of isolating organic acids, carbohydrates, proteins, alcohols, esters, and bases with the prospect of securing an idea as to the origin, the interrelations, and the fate of these substances.

In animal physiology, work of this nature has yielded far reaching results in the formulation of our present day conceptions of the relations of the individual to his nutritional environment. Especially is this evident in problems pertaining to energy relations and those concerned with the constructive process of growth and maintenance. But, as these have been developed, it has become increasingly evident that, if our conception of physiological processes in various fields is to be built up symmetrically, it becomes imperative that information on the nature of the vitamins be accumulated so that their specific rôle in the animal body can be determined. Funk (1), and Braddon and Cooper (2), who sur-

* Published with the permission of the Director of the Wisconsin Agricultural Experiment Station.

mised a relation between polyneuritis as caused by an insufficiency of the water-soluble vitamine and carbohydrate metabolism, and then Drummond (3), who investigated the effect of the water-soluble vitamine on nitrogen metabolism and the effect of the fat-soluble vitamine on fat metabolism, are the only investigators—as far as we know—who sought to associate the rôle of vitamines with the general body metabolism.

It is true that much of immediate practical importance in vitamine relations may be gained by a study of the dietary properties of various foodstuffs fed singly and in combinations, but it is not to be questioned that ultimately a true conception of problems in nutrition is dependent on the determination of the occurrence of various substances in foods and a development of an appreciation of their physiological rôle. We refer here to the effect of various substances on secretion, motor activity, irritability, conductivity, permeability, and cell proliferation all of which are concerned in such a gross physiological process as growth.

In the field of vitamine physiology, progress in the suggested direction is beset with many difficulties as shown by the fact that no vitamine has as yet been isolated. If it is not the lability of the compound in question, it is its extreme chemical indifference to such reagents as are ordinarily used to modify solubilities that prevents its separation from its environment. The present state of our knowledge is such that any indications as to the probable nature of a vitamine is worthy of investigation. In the case of the fat-soluble vitamine we have adopted as our working hypothesis (4) that it is either identical with or else chemically related to certain yellow plant pigments. With this as a clue, which is an outgrowth of their often observed association in nature (5), methods leading to the extraction of certain yellow pigments have given us many pigmented solutions carrying the fat-soluble vitamine. While this appears promising, it seemed imperative—before developing this work extensively—to accumulate information as to the best sources available for the isolation of this dietary essential and also to determine its stability in such materials.

Unfortunately data on the distribution of the fat-soluble vitamine are very limited in the literature, and, such as there are, were to a large extent obtained when the laboratory technique of determining dietary relations was not so highly developed as it is

at the present time. This situation has been discussed by Osborne and Mendel (6) in a preliminary communication in which they have submitted some data, but here again their data are not directly comparable with ours so that we have been obliged to continue with our accumulation of information to bring out what we shall present later. In the present paper we present data on the fat-soluble vitamine content of alfalfa, clover, spinach, lettuce, cabbage, and chard, and in addition present some data on their water-soluble vitamine content as well.

EXPERIMENTAL.

As in the previous papers of this series (5, 7, 8) the relative amount of fat-soluble vitamine present in the various plant tissues was determined by establishing the minimum amount—down to 5 per cent of the ration—necessary to satisfy the growth impulse of a recently weaned young rat for a period of at least 4 months. Using this technique it is, of course, necessary to have the young animals, as near as possible, of the same age and in good condition at the start of the experiment. Furthermore, it is imperative to know that in the experimental ration all other dietary requirements are complied with, so that growth is possible when a deficiency in the fat-soluble vitamine content does not occur or when it is corrected. Such a ration is readily formulated in a basal mixture consisting of purified casein, dextrin, agar, salts,¹ and water-soluble vitamine. The latter was usually incorporated as an alcoholic solution of ether-extracted wheat embryo, but sometimes as ether-extracted wheat embryo itself. As a rule, four experimental animals were fed in a group to eliminate individual differences by the law of averages.

Fat-Soluble Vitamine Content of Alfalfa.

Probably more of the statements relative to the fat-soluble vitamine content of leafy materials are based on data obtained with alfalfa than with any other materials, but unfortunately one is unable to glean from the information available, as pointed out

¹ For composition of salt mixtures see Steenbock, H., Boutwell, P. W., and Kent, H. E., *J. Biol. Chem.*, 1919, xxxv, 517; Steenbock, H., and Gross, E. G., *J. Biol. Chem.*, 1919, xl, 501.

thermore, young were successfully reared. Rat 683 raised two young out of a litter of seven to an average weight of 42 gm. in 32 days. While the time for rearing was prolonged 8 to 10 days beyond the normal, the fact that the rearing of young was possible gives indisputable evidence of the richness of alfalfa in the fat-soluble vitamine as the other ingredients of the ration have repeatedly been shown to be free from it. How much less than 5 per cent of the ration might have been constituted of alfalfa and

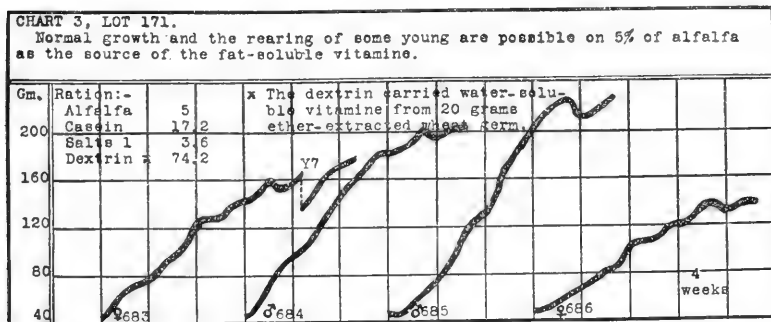

CHART 3.

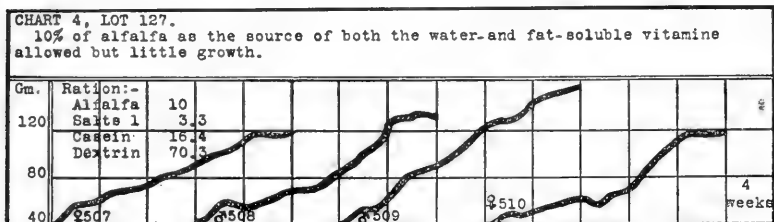

CHART 4.

still have produced results such as the above we have not determined, but we are inclined to think that with our material we had reached approximately the lowest level possible. This is suggested by the curves of growth and the behavior of the young.

Having established that normal growth and the rearing of some young are possible on 5 per cent of alfalfa no question of a fat-soluble vitamine deficiency could be raised in the case of a ration containing 10 per cent of alfalfa, as shown in Chart 4. Failure to grow at the normal rate must be attributed to a lack of a sufficient

amount of the water-soluble vitamine as in the lots pictured in Charts 1 and 2. No symptoms such as the convulsions of polyneuritis were observed nor were they expected as animals growing at the rate indicated will often continue their subnormal rate of growth for many months with no signs of collapse.

When the amount of alfalfa was increased to 15 per cent, Chart 5, the requirements of the rat for both the fat- and water-soluble vitamins were satisfied; normal growth and the rearing of young became possible. Rat 342 raised three young to an average weight of 43 gm. in 4 weeks.

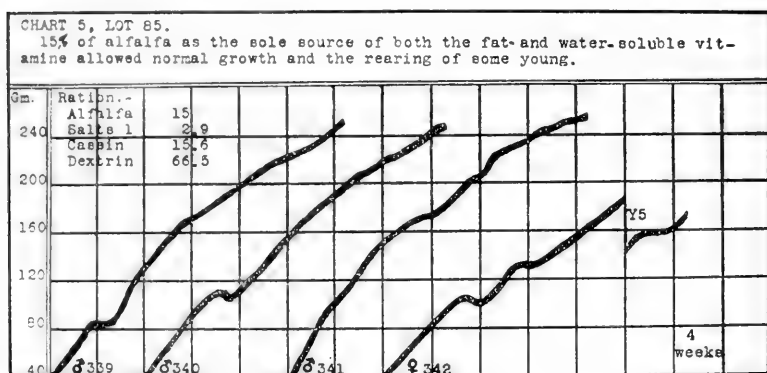

CHART 5.

Fat-Soluble Vitamine Content of Clover.

The clover used in these experiments was red clover which had completed its growth and almost its blossoming as only an occasional red blossom appeared among the numerous turning heads. It was dried in the laboratory at room temperature, then ground to a meal, and as such incorporated in the ration.

Chart 6 shows definitely that our clover fed at a 5 per cent level like the alfalfa (Chart 1) did not introduce sufficient water-soluble vitamine into our basal ration to allow growth. The fat-soluble vitamine on the other hand was introduced in considerable amounts with this amount of clover as is evident from the prompt inception of growth in Rats 2328, 2329, and 2331 when the water-soluble vitamine deficiency was corrected by the addition of an

alcoholic extract from ether-extracted wheat embryo. Rat 2330 had died as a result of lack of the water-soluble vitamins before the addition was made.

In Chart 7 are shown the curves of growth of rats on 5 per cent of clover as the source of fat-soluble vitamins in the ration when the water-soluble vitamin deficiency had been corrected from the

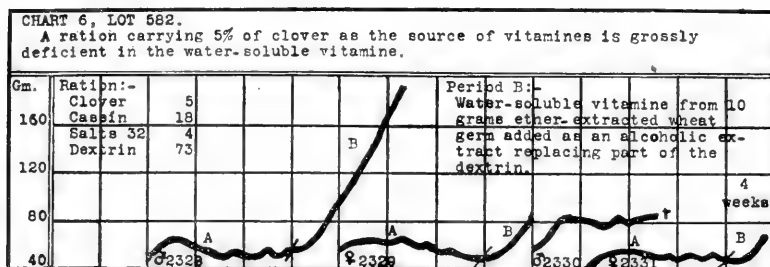

CHART 6.

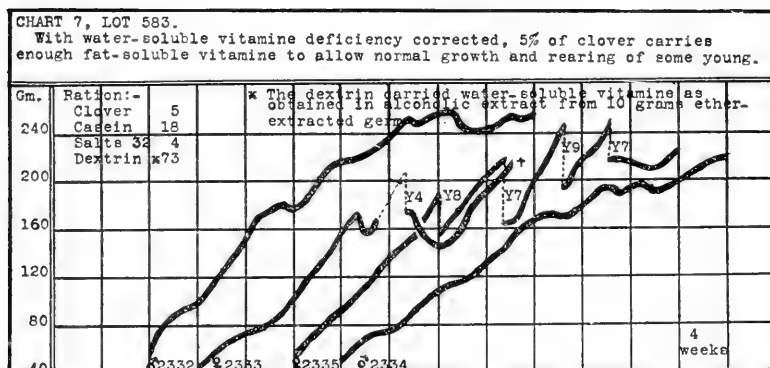

CHART 7.

very start of the experiment by an extract of wheat germ. Growth approximating normal was the result and, as in the case of alfalfa when fed at this level, young were reared though at a subnormal rate of growth. By way of illustration, Rat 2333 raised two out of a litter of four weighing 6 gm. as an average to an average weight of 36 gm. in 9 weeks. They were very small for their age as they should have had this weight when 3 weeks old, but they continued to grow on the ration and when discarded were rated as being

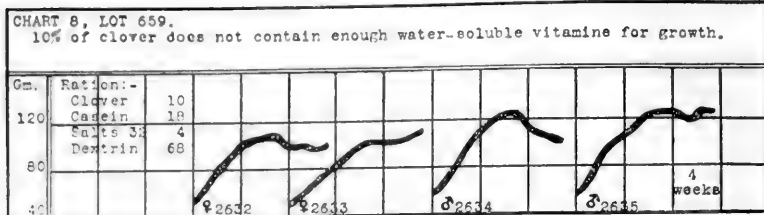

CHART 8.

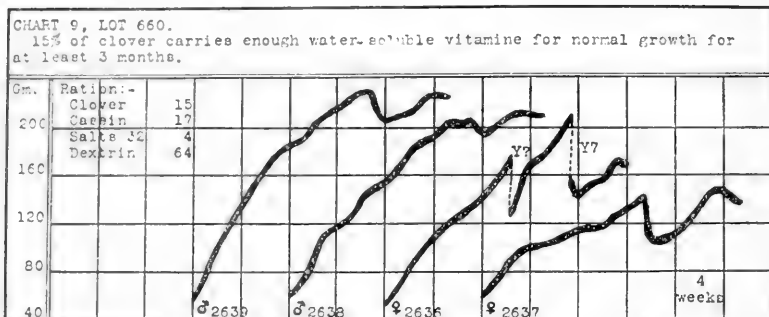

CHART 9.

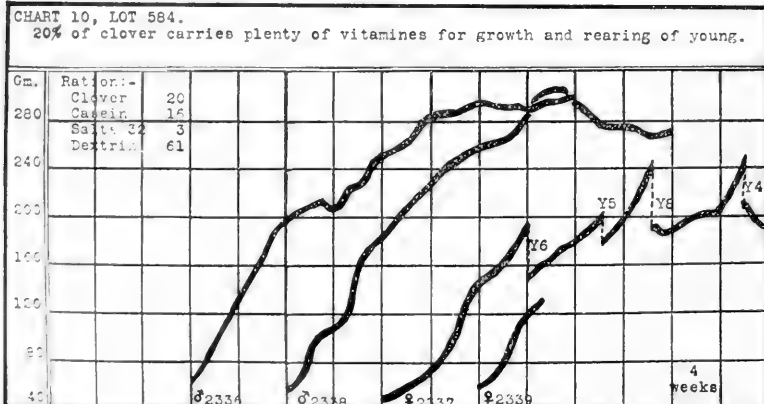

CHART 10.

in good condition. Rat 2335 did not raise her first three litters, but two out of her fourth litter were raised in 6 weeks and 4 days to an average weight of 42 gm., which again is distinctly sub-normal.

Having established the dietary efficiency of clover as a source of the fat-soluble vitamine when fed at a 5 per cent level, especially for growth, it must be concluded that the failure of growth when the clover was fed at a 10 per cent level as supplemented in our standard basal ration (Chart 8) must have been due to a water-soluble vitamine deficiency. When increased to 15 per cent (Chart 9) the rate of growth approached the normal. It was not, however, until 20 per cent of the ration was constituted of dried clover that growth was entirely satisfactory and that young were successfully reared (Chart 10). Rat 2339 was accidentally killed by the attendant, but Rat 2337 raised four of her litter of eight to an average weight of 44 gm. in 4 weeks. Her first and second litters were not raised which may, however, have been due to negligence as after parturition she was not segregated from the other members of this group. Under such conditions a perfectly healthy, well nourished animal sometimes discontinues nursing her young and death results from starvation.

Fat-Soluble Vitamine Content of Cabbage.

For these experiments cabbage as purchased on the local market was cut up fine and dried in the laboratory in an air current at room temperature. When in air-dried condition it was finally desiccated over CaCl_2 and then ground to a flour for incorporation in the ration.

The growth of rats on 5 per cent of this cabbage as the source of water-soluble vitamine shown in Chart 11 bears testimony that cabbage is not very rich in this vitamine; yet as the curves of growth are better than those where 5 per cent of alfalfa and clover (Charts 1 and 6) was the source of this vitamine, it is possible that cabbage may contain more of it. In spite of the comparatively greater initial weekly increments of growth, when failure threatened to ensue, decline in weight was prompt and decisive and moreover in two of the animals, Rats 715 and 716, observed convulsions of polyneuritis left no doubt as to the exact status

of their nutritive condition. With cabbage increased in amount to 15 per cent of the ration (Chart 12) the degree of growth and its maintenance were much improved and in three of the four animals it could be considered normal. Young were not reared.

As a source of the fat-soluble vitamine we had little success in demonstrating that cabbage is very efficient for probably a number of reasons. For one thing, cabbage when fed at high levels

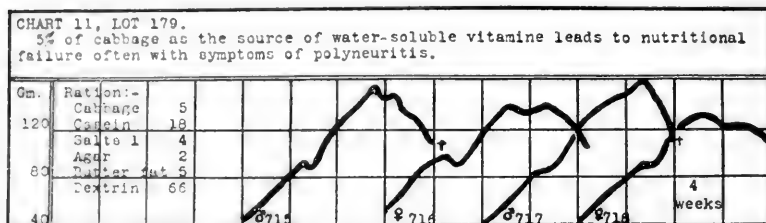

CHART 11.

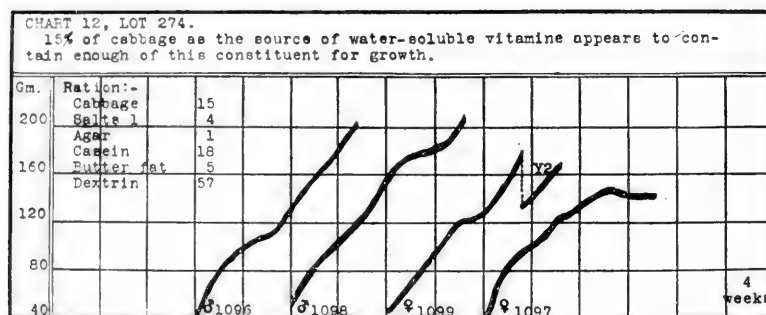

CHART 12.

is very liable to cause digestive disturbances which result in a decreased food intake with therefore a complication in the number of factors operative in the inhibition of growth. With 15 per cent of the ration constituted of cabbage, Rats 668, 669, and 670 were able to grow at a subnormal rate and maintain themselves without any of the secondary symptoms of a fat-soluble vitamine deficiency for 26 weeks which argues strongly for the presence of considerable amounts of this vitamine, yet when the amount was increased at this point by the addition of butter fat a prompt ac-

celeration in the rate of growth occurred (Chart 13). From our data we are inclined to conclude that cabbage is not a good material for the isolation of the fat-soluble vitamine, especially as with its extraction unpalatable volatile oils are removed in large amounts.

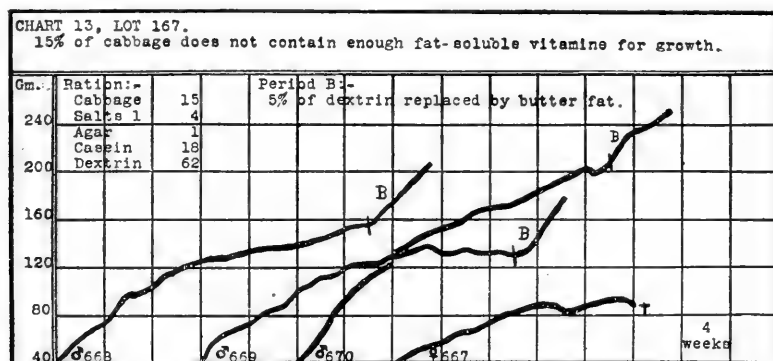

CHART 13.

Fat-Soluble Vitamine Content of Lettuce, Spinach, and Chard.

The plant materials lettuce, spinach, and chard as used in these experiments represented the stems as well as leaves of the plants as sold on the markets for household use. They were dried at room temperature in an air current and ground to a meal.

As the amounts of the above materials were limited, our observations here are not so extensive as with alfalfa and clover. Our technique was also modified in that water-soluble vitamine in all the rations was incorporated as ether-extracted wheat embryo—since from previous experience we had reason to believe that these materials were deficient in it. From the fat-soluble vitamine standpoint the use of wheat germ was entirely justifiable as with it none of this vitamine appeared to be introduced in the ration (Chart 14).

Charts 15, 16, and 17 show that 5 per cent respectively of lettuce, spinach, and chard in our basal ration furnishes enough fat-soluble vitamine for long continued though somewhat subnormal growth. Few young were produced and none was reared, but in no case

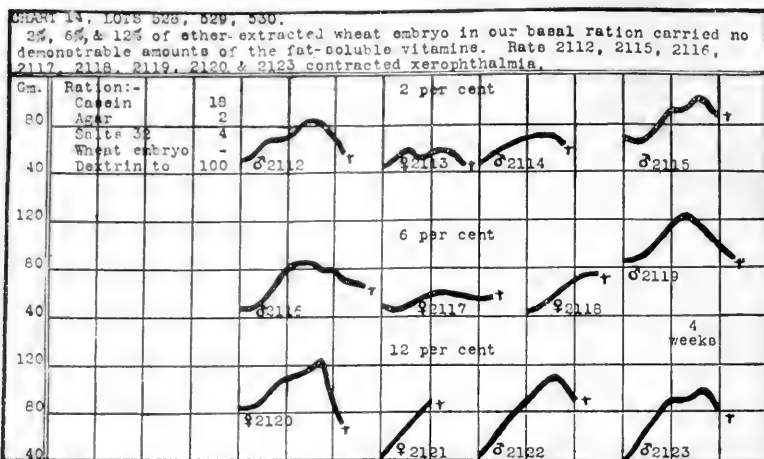

CHART 14.

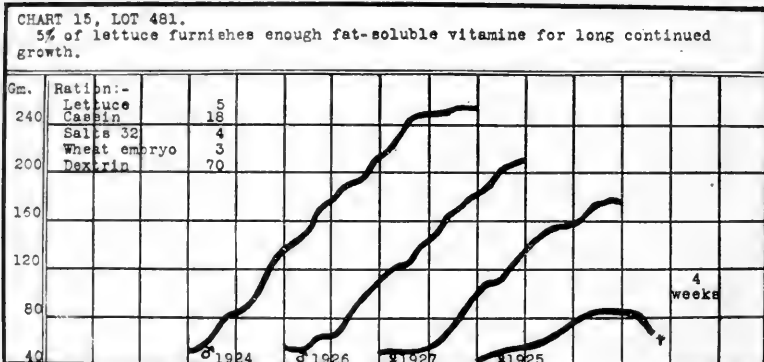

CHART 15.

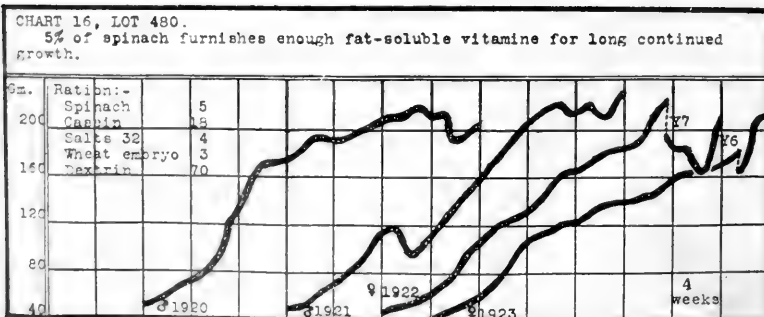

CHART 16.

was there any evidence of xerophthalmia. As judged by appearance, which is far more indicative of an animal's condition than evidence of weight relations alone, the spinach group was in the best condition and the lettuce the poorest.

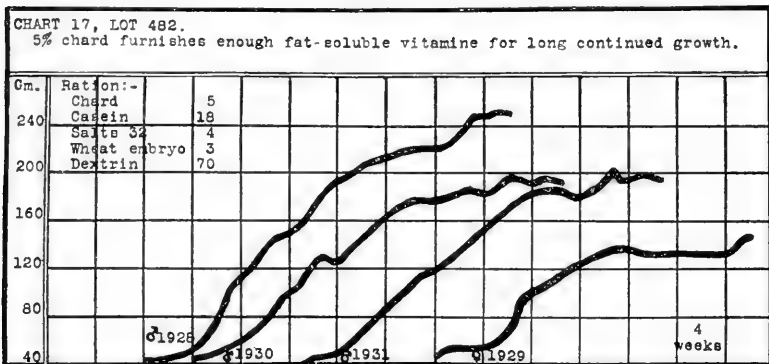

CHART 17.

DISCUSSION.

Whatever may be the reason in the physiological economy of the plant, it appears that of the plant structures the leaves are generally richest in the fat-soluble vitamine, some roots are next in order and last, at least of those investigated, are grains. In this we can see no correlation in the occurrence of the vitamine and the storage function as repeatedly enunciated by McCollum (9), but on the other hand we are assuming for our working hypothesis that where certain yellow plant pigments occur there we may look for the presence of the fat-soluble vitamine. In harmony with this, it is seen that cabbage in the head, containing little pigment, is not to be compared in physiological activity with the other leafy substances and of these latter, lettuce, also somewhat etiolated, is the poorest. Further details of this will be presented later as work now in progress is completed.

SUMMARY.

5 per cent of clover or alfalfa as the sole source of fat-soluble vitamine in a ration, when other dietary requirements are satisfied, allows normal growth and the rearing of some young.

Lettuce, spinach, and chard contain fat-soluble vitamine in amounts of similar magnitude, but of these lettuce may be the poorest.

In harmony with our theory of fat-soluble vitamine distribution and the occurrence of certain yellow plant pigments cabbage does not contain much of this vitamine as is shown by the poor results obtained even when fed at a 15 per cent level.

While 10 per cent of alfalfa and clover was inefficient, 15 per cent of either furnished enough water-soluble vitamine for normal growth; 20 per cent of clover gave still better results.

Cabbage furnished enough water-soluble vitamine when fed at a 15 per cent level.

BIBLIOGRAPHY.

1. Funk, C., *Z. physiol. Chem.*, 1914, lxxxix, 378.
2. Braddon, W. L., and Cooper, E. A., *J. Hyg.*, 1914, xiv, 351.
3. Drummond, J. C., *Biochem. J.*, 1918, xii, 25; 1919, xiii, 95.
4. Steenbock, H., *Science*, 1919, l, 352.
5. Steenbock, H., and Boutwell, P. W., *J. Biol. Chem.*, 1920, xli, 81.
6. Osborne, T. B., and Mendel, L. B., *J. Biol. Chem.*, 1919, xxxvii, 187.
7. Steenbock, H., Boutwell, P. W., and Kent, H., *J. Biol. Chem.*, 1918, xxxv, 517.
8. Steenbock, H., and Gross, E. G., *J. Biol. Chem.*, 1919, xl, 501.
9. McCollum, E. V., *J. Home Econ.*, 1918, x, 195.

FAT-SOLUBLE VITAMINE.*

V. THERMOSTABILITY OF THE FAT-SOLUBLE VITAMINE IN PLANT MATERIALS.

BY H. STEENBOCK AND P. W. BOUTWELL.

WITH THE COOPERATION OF MARIANA T. SELL AND E. G. GROSS.

(From the Laboratory of Agricultural Chemistry, University of Wisconsin, Madison.)

(Received for publication, December 23, 1919.)

In the immediately preceding paper of this series (1) we have stated the necessity of securing definite knowledge of the stability of the fat-soluble vitamine as one of the preliminaries leading to its isolation. In regard to the stability of this vitamine there appears to be no unanimity of opinion. Osborne and Mendel (2), and McCollum and Davis (3) are sponsors for the statement that it is thermostable—though the former observed one instance of its destruction by aging—while Steenbock, Boutwell, and Kent (4), and Drummond (5) have shown that it is not so stable as is generally accepted, in fact the latter was inclined to believe that he was dealing with an enzyme-like compound. While we are not inclined to subscribe to Drummond's surmial, yet we have obtained abundant evidence that under certain conditions this vitamine is very labile, but we also have available evidence that under other conditions it may be very stable. These differences can be readily reconciled as it would be surprising indeed if variations in the stability of this substance should not occur in the very varied chemical environment in which it has been found.

The first information in this connection was presented by McCollum and Davis (3) who found extracts of egg still efficient though the yolks had previously been coagulated by heat. Osborne and Mendel (2) suspected that the impotency of commercial lard might be due to the rather drastic heat treatment to

* Published with the permission of the Director of the Wisconsin Agricultural Experiment Station.

which the pig tissues had been subjected in the process of extraction, but this was found unwarranted as lard prepared by them in the laboratory with minimum exposure to heat was found just as inactive. Furthermore, butter fat treated with live steam for 2½ hours was still found a source of the vitamine, though it is not stated how much was required to demonstrate that it was present in adequate amounts. Subsequently these same investigators (6) report that butter fat kept at temperatures of 8-18° in the dark and also when exposed to the light did not lose its vitamine. Butter oil obtained by removal of the harder fats from butter by crystallization from warm absolute alcohol, on the other hand, gradually lost its activity even when kept at 8° and in the dark. Drummond (7) found that cod liver oil and whale oil, both of which had been obtained by steam digestion of the tissues, were still very active and therefore surmised that the vitamine was thermostable. Later, however, he substantiated the findings of Steenbock, Boutwell, and Kent (4) that its thermostability in fats such as butter is not very great. Osborne and Mendel (8) have shown that pig tissues such as liver, heart, and kidney contained the fat-soluble vitamine even though they had been dried at 90° for some hours.

In this brief résumé of the literature it is seen how little the matter of the stability of the fat-soluble vitamine has been investigated. It is believed that the data of the different investigators in this field are substantially true to fact and that the variance of opinion is due to a failure to appreciate that the reaction of destruction may be one of low velocity impeded or accelerated by secondary factors. In a ration containing twice as much vitamine as necessary for normal growth no evidence of its destruction would of course be obtained even though one-half of the amount present might have been destroyed by the treatment. In addition, there is no doubt that there obtains a great difference in the stability of the vitamine as found in different materials. This is brought out in the comparison of our previous data with those in the present paper in which are presented data on its thermostability in various plant materials.

EXPERIMENTAL.

The experimental technique used in these experiments was substantially the same as outlined in other publications of this series (1, 4, 9, 10) to which the reader is referred for details. Rats were used as the experimental animals. Shortly after weaning, they were placed on a diet which in its mixture of ingredients was known to satisfy all the dietary requirements of the animal except for the fat-soluble vitamine. The introduction of this latter component was left to that moiety of the ration which consisted of the heated plant materials. These were prepared by autoclaving them for 3 hours at approximately 15 pounds pressure—after soaking in water as they were all air-dried—and then drying them at room temperature in an air current. It was expected that by heating in the autoclave considerable amounts of the vitamine had been destroyed and with this in mind it was thought preferable to dry the materials finally at room temperature rather than in an oven. The growth curves are presented as evidence of the efficiency of the ration in furnishing the requisite amount of the fat-soluble vitamine.

In Chart 1 are presented data obtained with yellow maize, chard, and alfalfa. The maize was of the variety known as Golden Glow or Wisconsin No. 12 and was part of a lot of which the vitamine content had been determined (10). At that time reasons were given for concluding that yellow maize contains just sufficient fat-soluble vitamine to allow normal growth in some animals, but not in all. With this in mind the observed rate of growth of Rats 2503 and 2500, which is of normal proportions, has considerable significance. The somewhat subnormal rate of Rats 2501 and 2502 does not detract from this, as, by the law of averages, it is what might have been expected with animals fed on the unheated maize due to variations in the ability to grow on slightly deficient diets. It is believed safe to conclude that none of the fat-soluble vitamine of yellow maize was destroyed by autoclaving at 15 pounds pressure for 3 hours.

Chard as one of the leafy plant materials has been shown to be comparatively rich in its content of the fat-soluble vitamine (1); 5 per cent being sufficient in a low calorie ration for long continued growth. Autoclaving does not appear to result in a

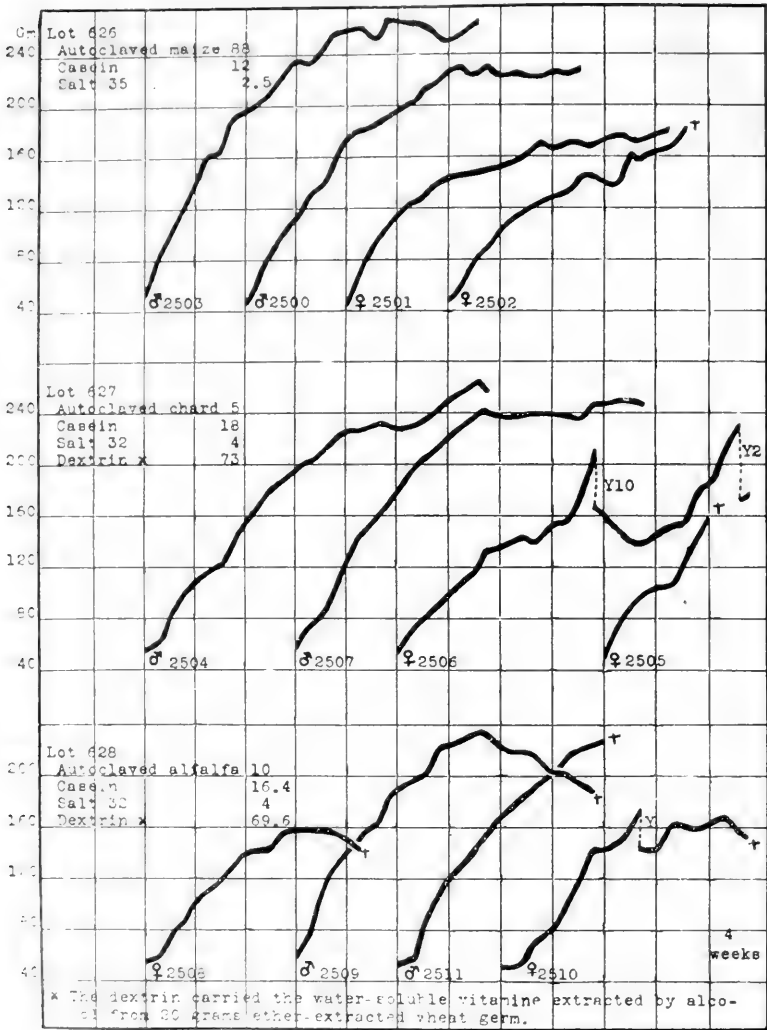

CHART 1.

diminution of its vitamine content as evident from the remarkable performance of the rats in Lot 627, Rat 2506 even rearing two out of its first litter when reduced to five young. If comparisons are made in the curves of growth of rats in this lot with those in the previous publication (1) where the unheated chard was fed, it will be noted that the latter are more nearly normal. It is believed that this discrepancy can be accounted for by the fact that the rats getting the unheated chard had water-soluble vitamine introduced in their rations as ether-extracted wheat embryo which is more depressing in its effect on growth than an alcoholic extract of the same.

In the experiment designed to bring out the effect of heat on alfalfa the autoclaved alfalfa was fed at a level at least twice as high as necessary for normal growth so that a low degree of vitamine destruction would have remained undetected. As it was, the rats grew normally on this ration for 3 to 4 weeks indicating a sufficiency of the vitamine and then declined and died. Rats 2508 and 2509, and possibly 2510, as further indications of a fat-soluble vitamine deficiency, contracted xerophthalmia before death. The condition of Rat 2511 indicated respiratory difficulty, but was not further examined. It hardly appears justifiable to conclude that a fat-soluble vitamine destruction by heat alone was responsible for this condition, especially in view of the excellent growth that had prevailed up to the time of the incidence of the disease. We reserve drawing final conclusions as either one of two possibilities appears acceptable. Either the rapid decline of the animals was occasioned by infection with an especially virulent form of the organism or organisms responsible for xerophthalmia or else while the fat-soluble vitamine was not destroyed by the heat treatment itself it was made more susceptible to destruction—possibly by liberation from combinations—by the agents operative in the aging process. What these are we do not know, but it is to be remembered that the alfalfa used in these experiments was a commercial alfalfa meal of which the history with respect to method of curing was not known. In one series of experiments carried out 2 years ago we found that the vitamine was not destroyed in the ensiling process. When green immature alfalfa was kept in a 20 gallon tub sealed air tight a considerable temperature and acidity developed in the course of 7 days. At

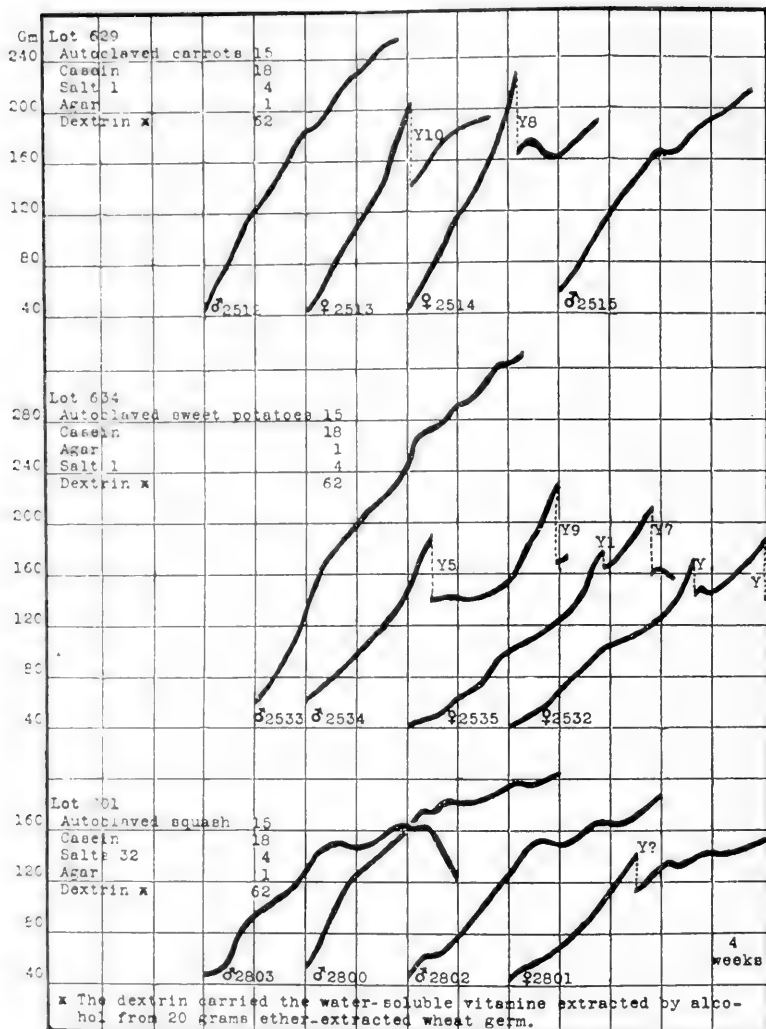

CHART 2.

the conclusion of this period the material when air-dried and fed at a 10 per cent level as the source of both the fat- and water-soluble vitamines allowed a 40 gm. male rat to attain a weight of 240 gm. in 16 weeks. Here we had a considerable acidity acting at a temperature of approximately 35° in the absence of oxygen and later—in the air drying process at room temperature—in the presence of oxygen with no complete destruction of either vitamine.

Carrots and sweet potatoes (9) both excellent sources of the fat-soluble vitamine suffer no appreciable loss of their vitamine by being autoclaved at 15 pounds pressure for 3 hours and then dried at room temperature. This is shown in Chart 2, Lots 629 and 634, where rats made very satisfactory growth when fed with

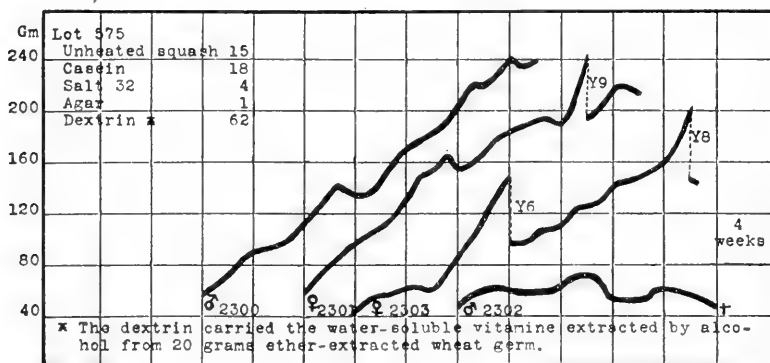

CHART 3.

these materials at 15 per cent levels. In the previous publication a fairly satisfactory degree of growth was reported with the unheated material. That the performance was here improved by the heating process is to be attributed to the reduction of the tendency to tympanites induced by the hemicelluloses in the raw materials. On both heated carrots and sweet potatoes young were successfully reared; Rat 2514, receiving carrots, raising five out of her litter of eight to an average weight of 44 gm. in 4½ weeks and Rat 2534, on sweet potatoes, raising a litter of five to an average weight of 49 gm. in 6 weeks. In view of the performance of the rats on the unheated materials we do not believe that this would have been possible if there had been any considerable destruction of the fat-soluble vitamine.

Up to the present there have not been available any data on the vitamine content of squash. If our theory of the association of certain yellow pigments and the fat-soluble vitamine (10, 11) is generally applicable in the plant kingdom it was to be surmised that the Hubbard squash which has flesh of a golden yellow would be rich in this constituent. We have not yet tested other varieties, but this particular variety was found to contain considerable amounts of the vitamine (Chart 3, Lot 575). Furthermore, like the other materials tested, its vitamine was not destroyed by autoclaving at 15 pounds pressure for 3 hours (Chart 2, Lot 701). The squash used in these experiments had been prepared, after peeling, by drying at room temperature in an air current and later over anhydrous calcium chloride. For autoclaving, it was soaked in water and after autoclaving it was again dried at room temperature. With neither the raw nor the heated squash was the growth entirely satisfactory, but that this was not due to a vitamine deficiency is attested to by the fact that in Lot 575 Rat 2303 successfully reared five young out of her litter of six to an average weight of 49 gm. in 7 weeks.⁹ Though this rate of growth was decidedly subnormal they were very active and of good appearance which would not have been the case if there had been a deficiency of the fat-soluble vitamine.

SUMMARY.

A process of heat treatment consisting of autoclaving for 3 hours at 15 pounds pressure does not destroy any of the fat-soluble vitamine as found in yellow maize. Neither does this treatment cause any noticeable destruction of the vitamine in chard, carrots, sweet potatoes, and squash as demonstrated when these materials are fed in percentages of the ration varying from 5 to 15. If some destruction occurred it was not detected, but with the amounts fed it is not believed that it could have occurred to any considerable degree, otherwise normal growth or long continued growth with reproduction would not have been possible. In the case of alfalfa the data are not decisive, but it appears that the autoclaving process in itself did not destroy the vitamine to the extent that a deficiency in the ration was thereby induced. Neither in a short time experiment was any deleterious action

of the ensiling process on the fat-soluble vitamine demonstrable. Our experiments demonstrate that the fat-soluble vitamine as found in the plant kingdom in a grain, in leaf and stem tissue, in fleshy roots, and in a cucurbitous vegetable is comparatively stable at a high temperature.

BIBLIOGRAPHY.

1. Steenbock, H., and Gross, E. G., *J. Biol. Chem.*, 1920, xli, 149.
2. Osborne, T. B., and Mendel, L. B., *J. Biol. Chem.*, 1915, xx, 379.
3. McCollum, E. V., and Davis, M., *Proc. Soc. Exp. Biol. and Med.*, 1913-14, xi, 101.
4. Steenbock, H., Boutwell, P. W., and Kent, H. E., *J. Biol. Chem.*, 1918, xxxv, 517.
5. Drummond, J. C., *Biochem. J.*, 1919, xiii, 81.
6. Osborne, T. B., and Mendel, L. B., *J. Biol. Chem.*, 1915, xxiv, 37.
7. Drummond, J. C., *J. Physiol.*, 1918-19, lii, 95.
8. Osborne, T. B., and Mendel, L. B., *J. Biol. Chem.*, 1918, xxxiv, 17.
9. Steenbock, H., and Gross, E. G., *J. Biol. Chem.*, 1919, xl, 501.
10. Steenbock, H., and Boutwell, P. W., *J. Biol. Chem.*, 1920, xli, 81.
11. Steenbock, H., *Science*, 1919, l, 352.



PHOSPHORUS REQUIREMENT OF MAINTENANCE IN MAN.*

By H. C. SHERMAN.

WITH THE COOPERATION OF A. R. ROSE, MATHILDE KOCH, ELIZABETH
MATHEWS, AND EMIL OSTERBERG.

(From the Department of Chemistry, Columbia University, New York.)

(Received for publication, December 15, 1919.)

It has for some years been inferred from the observations upon intake and output, and recently demonstrated conclusively by feeding experiments with rations otherwise adequate but deficient in one or more of the inorganic elements,¹ that considerable amounts of phosphorus are required in the normal nutrition of animals. Less emphasis than formerly is now placed upon the form of chemical combination in which the phosphorus is furnished by the food. Thus it becomes logical to discuss the amounts of phosphorus required for nutrition under different conditions without necessarily giving detailed consideration to the nature of the food intake in each case. Special interest attaches to the phosphorus requirement in man because the practise of so milling the cereal grains that the phosphorus-rich portions go to the feeding of farm animals while the parts poor in phosphorus are used for human food makes the danger of phosphorus deficiency relatively greater in human than in animal nutrition, unless it is found by adequate quantitative investigation that this tendency is fully offset by certain factors of safety of which two may be especially mentioned: (1) Growth is relatively less rapid in the child than in the young of most domesticated animals, while muscular activity at corresponding ages is probably fully as pronounced; (2) adult man may in the majority of cases be somewhat more active than the average of those adult farm animals which are

* Published as contribution No. 331 from the Department of Chemistry, Columbia University.

¹ Osborne, T. B., and Mendel, L. B., *J. Biol. Chem.*, 1918, xxxiv, 131.

kept merely in a condition of maintenance or fattening as distinguished from those which serve as draft animals. For either or both of these reasons it may be that the ratio of phosphorus requirement to energy requirement is enough lower in man than in his farm animals to counterbalance the tendency to a lower percentage of phosphorus in his food, as long as his total food intake is adequate to meet his energy requirement. That grain products may constitute a smaller proportion of the entire food intake of man than of many farm animals may or may not be a factor of safety—for, while some foods such as milk and eggs are very effective supplements to the grain products in this respect (as in several others), other foods equally widely used such as butter and sugar are practically devoid of phosphorus compounds so that their inclusion in the dietary puts man at a further disadvantage in respect to his phosphorus intake.

During the past 15 years a considerable number of experiments upon the phosphorus requirement of maintenance in man have been carried out in this laboratory. The data of several of these have been included in papers previously published, sometimes with,² sometimes without,³ specific discussion of their bearing upon the present problem. The purpose of this paper is to place on record such of our experimental data as have not appeared elsewhere, and to summarize briefly the evidence of all available experiments which now seem to us to permit of direct quantitative comparison.

Experimental Data Not Recorded in Previous Papers.

Subject F, a woman of 64 kilos (studied in 1911), on a diet of bread, meat, potato, rice, prunes, butter, sugar, and tea which was estimated to furnish 0.95 gm. of phosphorus per day, showed the following average elimination in four successive periods of 3 days each which followed each other without intermission: in urine, 0.55, 0.53, 0.45, 0.50; in feces, 0.27, 0.30, 0.19, 0.23 gm.

² Sherman, H. C., Mettler, A. J., and Sinclair, J. E., *U. S. Dept. Agric., Office Exp. Stations, Bull.* 227, 1910. Sherman, H. C., Gillett, L. H., and Pope, H. M., *J. Biol. Chem.*, 1918, xxxiv, 373. Sherman, H. C., Wheeler, L., and Yates, A. B., *J. Biol. Chem.*, 1918, xxxiv, 383.

³ Sherman, H. C., and Winters, J. C., *J. Biol. Chem.*, 1918, xxxv, 307.

respectively. It is possible that the actual intake may have been somewhat less than the analytical data indicate due to an accident which permitted partial drying of some of the foods while the samples were being taken for analysis. This, however, would in no wise affect the data of the output which we take to be an approximate indication of the phosphorus requirement of this subject (see Nos. 21 to 24 in Table I).

Subject I, a man of 61 kilos studied by A. R. Rose and the writer in 1912, took a diet consisting of bread, wheat farina, rice, egg white, milk, butter, coffee, and apple sauce, giving an intake in five successive experiments of 0.65, 0.65, 0.64, 0.56, and 0.56 gm. of phosphorus per day. These experiments followed each other without intermission and were preceded by 3 days of similar diet. The average daily output of phosphorus in each of the five experiments was as follows: in urine, 0.57, 0.60, 0.56, 0.46, 0.43; in feces, 0.26, 0.12, 0.14, 0.16, 0.09 gm. respectively. There was thus a slight minus balance at first and practical equilibrium in the latter part of the time covered by the investigation. The data of output calculated to uniform basis appear under Nos. 25 to 29 in Table I.

Subject H, a woman of 65 kilos studied in 1914, took a diet of bread, butter, wheat breakfast food, meat, potato, peanuts, and oranges with an intake of 0.61 gm. of phosphorus per day and an average daily output in each of three successive 3 day experiments as follows: in urine, 0.60, 0.68, 0.76; in feces, 0.17, 0.17, 0.19 gm. respectively (Nos. 30 to 32 in Table I).

Subject E, a man of 69 kilos studied in 1916, after 10 days on phosphorus-poor food, took during a 3 day experiment a diet of bread, butter, meat, apple, and milk furnishing 0.76 gm. of phosphorus, while the daily output for the same 3 day period was: in urine, 0.75; in feces, 0.18 gm. (No. 71 in Table I).

Subject R, a man of 80 kilos (1916), took during a period of 15 days in five experiments of 3 days each, a diet of bread, butter, and apples which furnished in the successive periods 0.56, 0.53, 0.49, 0.52, 0.57 gm. of phosphorus per day; the average daily output during each experiment was: in urine, 0.61, 0.46, 0.51, 0.43, 0.44; in feces, 0.19, 0.16, 0.19, 0.19, 0.15 gm. respectively (Nos. 72 to 76 in Table I).

TABLE I.*

Indicated Phosphorus Requirements for Maintenance per 70 Kilos of Body Weight per Day.

Experiment No.	Phosphorus.	Experiment No.	Phosphorus.	Experiment No.	Phosphorus.
	gm.		gm.		gm.
1	0.87	33†	0.84	65†	1.04
2	0.95	34†	0.85	66†	0.80
3	0.83	35†	0.71	67†	0.89
4	1.02	36†	0.74	68†	0.89
5	1.09	37†	0.74	69†	0.89
6	0.78	38†	0.69	70†	0.98
7	0.89	39†	0.76	71	0.95
8	0.68	40†	0.76	72	0.70
9	0.73	41†	0.68	73	0.54
10	1.06	42†	0.90	74	0.62
11	1.13	43†	0.89	75	0.54
12	1.12	44†	1.14	76	0.52
13	0.98	45†	1.01	77†	0.85
14	1.19	46†	1.01	78†	0.88
15	1.04	47†	0.95	79†	0.78
16	0.90	48†	1.07	80†	0.76
17	0.96	49†	1.04	81†	0.82
18	1.13	50†	1.03	82†	0.88
19	1.04	51†	0.85	83†	0.89
20	1.02	52†	0.94	84	0.77
21†	0.90	53†	0.91	85	0.79
22†	0.91	54†	0.91	86	0.69
23†	0.70	55†	0.88	87†	0.72
24†	0.80	56†	0.90	88†	0.74
25	0.96	57†	1.06	89†	0.75
26	0.83	58†	1.01	90†	0.65
27	0.81	59†	1.01	91†	0.72
28	0.72	60†	1.03	92†	0.80
29	0.60	61†	0.90	93†	0.81
30†	0.83	62†	1.08	94†	1.20
31†	0.93	63†	1.07	95†	1.17
32†	1.03	64†	0.90		
Average.....					0.88

* Experiment 1, Sivén, V. O., *Skand. Arch. Physiol.*, 1901, xi, 308. Nos. 2 and 3, Gumpert, E., *Med. Klin.*, 1905, i, 1037. Nos. 4 and 5, Sherman, H. C., Mettler, A. J. and Sinclair, J. E., *U. S. Dept. Agric., Office of Exp. Stations, Bull.* 227, 1910. Nos. 6 to 9, Hämäläinen, J., and Helme, W.,

Subject Q, a man of 68 kilos (1917), took a diet of bread and milk which furnished in three successive 4 day experiments daily intakes of 0.70, 0.51, and 0.53 gm. of phosphorus respectively. The corresponding data of output were: in urine 0.58, 0.53, 0.53; in feces 0.20, 0.24, 0.12 gm. of phosphorus per day (Nos. 84 to 86 in Table I).

General Comparison of Available Data.

For convenience of comparison and discussion the data of these experiments and of all available previously published experiments which seem to be quantitatively comparable, have been calculated to the uniform basis of phosphorus output per day per 70 kilos of body weight on the same general principle as in the similar study of the protein requirement of maintenance.⁴ The data of "indicated phosphorus requirement" thus found are summarized in Table I.

It will be seen that the data of the 95 experiments range from a minimum of 0.52 to a maximum of 1.20 gm. with an average of 0.88 gm. of phosphorus per 70 kilos of body weight per day. The experiments upon men average 0.87 gm. and those upon women average 0.89 gm. per 70 kilos per day. The range of variation among the experiments is here quite similar (proportionately) to that found in a corresponding compilation of ex-

Skand. Arch. Physiol., 1907, xix, 182. Nos. 10 to 13, Berg, R., *Biochem. Z.*, 1911, xxx, 107. Nos. 14 to 20, Aron, H., and Hocson, F., *Biochem. Z.*, 1911, xxxii, 189. Nos. 21 to 24, Koch, M., and Sherman, H. C., not previously published. Nos. 25 to 29, Rose, A. R., and Sherman, H. C., not previously published. Nos. 30 to 32, Sherman, H. C., and Mathews, E. M., not previously published. Nos. 33 to 50, Sherman, H. C., Gillett, L. H., and Pope, H. M., *J. Biol. Chem.*, 1918, xxxiv, 373. Nos. 51 to 63, Sherman, H. C., Wheeler, L., and Yates, A. B., *J. Biol. Chem.*, 1918, xxxiv, 383. Nos. 64 to 70, Sherman, H. C., Gillett, L. H., and Pope, H. M., *J. Biol. Chem.*, 1918, xxxiv, 373. No. 71, Sherman, H. C., not previously published. Nos. 72 to 76, Sherman, H. C., and Osterberg, E., not previously published. Nos. 77 to 83, Sherman, H. C., Wheeler, L., and Yates, A. B., *J. Biol. Chem.*, 1918, xxxiv, 383. Nos. 84 to 86, Sherman, H. C., and Beegle, F. M., not previously published. Nos. 87 to 95, Sherman, H. C., and Winters, J. C., *J. Biol. Chem.*, 1918, xxxv, 307.

† Experiments upon women.

⁴ Sherman, H. C., *J. Biol. Chem.*, 1920, xli, 97.

periments upon the protein requirement. The same causes of variation are doubtless operative, but to different degrees in the two cases. In the study of protein requirement the earlier experiments in general tended to give high results because of failure to plan the diets properly or to continue them for a long enough time. These errors probably play less part in the phosphorus experiments here quoted since they are in the main of recent date and have been planned and carried out with these considerations in mind. As the experiments are arranged chronologically in Table I, it may be seen at a glance that there is no marked tendency to lower results among the later experiments. Probably, therefore, the question whether or not the experiment was sufficiently controlled and continued for a long enough time to test actual requirements was a less disturbing factor here than in the study of protein requirement. The function of phosphates in the maintenance of neutrality in the body may be one reason for the variations in the phosphorus output, although it has been shown⁵ that the surplus acid arising from the normal metabolism of a diet in which the acid-forming elements predominate may be eliminated in part as ammonia salt and in part as increased acidity of urine without necessarily increasing the output of phosphorus.

It is possible too that the nature of the phosphorus compounds of the intake may be of more significance than has usually been assumed during recent years. The fact that inorganic forms of phosphorus may serve to meet all the requirements of the phosphorus metabolism does not necessarily imply that all the phosphorus compounds of the intake have exactly the same quantitative efficiency in nutrition, when supplied in amounts barely adequate to meet actual needs.

While several of the factors determining the phosphorus output remain for further quantitative investigation, we are probably justified in concluding that we now know the phosphorus requirement with about the same probable accuracy that the protein requirement is known, and that about one-fortieth to one-fiftieth as much phosphorus (reckoned as element) as of protein is required in the maintenance metabolism of man.

⁵ Sherman, H. C., and Gettler, A. O., *J. Biol. Chem.*, 1912, xi, 323.

Compared with the quantities actually required for maintenance, the average food intake of typical American households appears to provide a somewhat more liberal margin of protein than of phosphorus. Yet in a detailed study of the food supplies of 224 families or other groups of people selected as typical of the population of different parts of the United States only eight showed less than 0.88 gm. of phosphorus per man per day and in all but two of these cases the phosphorus content would have reached this figure if the food consumed (without change in its character) had been increased in amount to a level of 3,000 calories per man per day. The two cases which apparently contained less than the average actual requirement of phosphorus and would still have been thus deficient if the food had been sufficient in amount to cover the energy requirement amply were both reported from southern states. McCollum, Simmonds, and Parsons, in discussing the results of experiments upon rats with diets made up in imitation of those whose use has been described as resulting in pellagra in man, express the opinion that "it may well be that the preponderance of products of the endosperm of seeds made the phosphorus content of the diet too low."⁶ This is in addition to the inadequacy of the food as regards calcium, fat-soluble A, and certain amino-acids, which they regard as characterizing the "pellagra-producing" diets of the South. Outside of the southern regions where the food supply consists too largely of patent flour or new process (degerminated) corn-meal supplemented chiefly by sugars and fats, the danger that a freely chosen American dietary will be deficient in either protein or phosphorus does not appear serious, in the light of our present evidence, so far as the requirements of maintenance are concerned.

What quantities of phosphorus in the food will best meet the requirements of growth, pregnancy, and lactation remains to be determined.

⁶ McCollum, E. V., Simmonds, N., and Parsons, H. T., *J. Biol. Chem.*, 1919, xxxviii, 130.

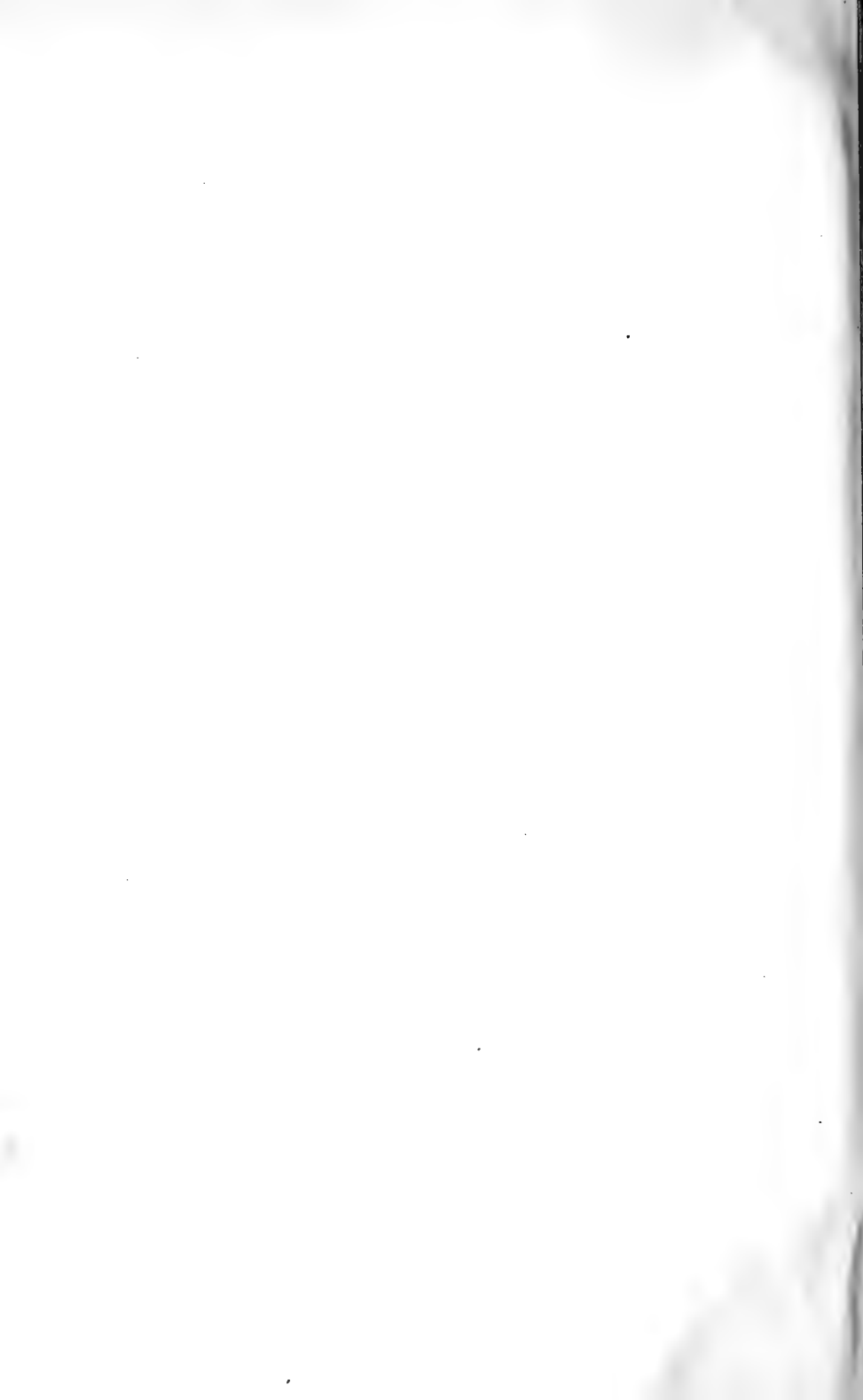

THE RÔLE OF PENTOSE-FERMENTING BACTERIA IN THE PRODUCTION OF CORN SILAGE.*

BY W. H. PETERSON AND E. B. FRED.

(From the Departments of Agricultural Chemistry and Agricultural Bacteriology, University of Wisconsin, Madison.)

(Received for publication, December 19, 1919.)

In a previous publication¹ on the xylose-fermenting bacteria, it was noted that these organisms are easily isolated from silage, and apparently occur there in large numbers. Their optimum temperature for fermentation was shown to be about 27°C.; which is approximately the average temperature found in ensiled corn. In relation to oxygen supply the pentose fermenters are most active when subjected to a low oxygen tension and will ferment xylose under anaerobic conditions. In this respect the reduced oxygen supply usually found in a silo should furnish suitable conditions for their growth.

The pentose fermenters are particularly characterized by the ease and rapidity with which they ferment pentoses, producing acetic acid and lactic acid as the chief end-products. Unpublished data on their power to ferment other sugars led to the interesting observation that from glucose they formed large quantities of alcohol, lactic acid, carbon dioxide, and small quantities of acetic acid. The fermentation of fructose by these organisms results in the formation of a characteristic product, mannitol. Dox and Plaisance² have isolated mannitol from silage in consider-

* This work was in part supported by a grant from the special research fund of the University of Wisconsin.

Published with the permission of the Director of the Wisconsin Agricultural Experiment Station.

¹ Fred, E. B., Peterson, W. H., and Davenport, A., *J. Biol. Chem.*, 1919, xxxix, 347.

² Dox, A. W., and Plaisance, C. P., *Iowa Agric. Exp. Station, Research Bull.* 42, 1917.

182 Pentose-Fermenting Bacteria and Silage

able quantities and its presence there is generally attributed to bacterial action.

Since xylose, or xylose-yielding substances, glucose, fructose, and other sugars, are found in abundance in green corn and since the above fermentation products are the chief chemical compounds formed in silage, a study of the relationship of these bacteria to silage production was undertaken.

For many years the relationship of microorganisms and of plant enzymes to the fermentation of silage has been studied. Some investigators have concluded that microorganisms are solely responsible for the changes in the ensilage, others that the plant enzymes are the chief causative agent. A third group of investigators has held that both factors are involved in this fermentation.³

In this article a brief report is presented of the results obtained from the inoculation of corn fodder at the time it was placed in the silo.

EXPERIMENTAL.

Numerous investigators have shown that normal silage can be produced under laboratory conditions by filling small containers with the cut corn and allowing the ensiled material to stand at a suitable temperature for a short time. The silage thus made possesses the same odor and taste, and yields on analysis the same products as silage made in the usual way. In these experiments, milk bottles closed with a one-hole rubber stopper through which passed a bent glass tube were used. The free end of the glass tube was sealed with mercury by inserting it into a test-tube containing 2 or 3 inches of mercury. Such an arrangement has been used with excellent results by Professor E. G. Hastings of the Agricultural Bacteriology Department in the experimental study of silage.

The first series was packed with rather green corn on September 5, 1919, and when filled contained 350 gm. of material in

³ For a review of the literature see Dox, A. W., and Neidig, R. E., *Iowa Agric. Exp. Station, Research Bull.* 7, 1912. Neidig, R. E., *Iowa Agric. Exp. Station, Research Bull.* 16, 1914. Sherman, J. M., *J. Bacteriol.*, 1916, i, 452. Lamb, A. R., *J. Agric. Research*, 1917, viii, 378. Hunter, O. W., *J. Agric. Research*, 1917, x, 82.

each bottle. Two bottles were used as controls and, except for the addition of 50 cc. of water, were untreated. Two others were sterilized, 50 cc. of sterilized water added, and kept as sterilized controls. Four bottles were sterilized and subsequently inoculated in duplicate with 50 cc. of a water suspension of the pentose-fermenting bacteria, Cultures 41-11 and 118-8. In order to insure growth, another set of bottles was inoculated with the same organism suspended in yeast water. The addition of this yeast water was found to be unnecessary as the bacteria grew just as well in the bottles to which no yeast water was added. The bottles were then incubated for 10 days at 27°C. During the period of incubation a strong evolution of gas was noted in all the bottles except in the sterilized uninoculated controls. In these a negative pressure was indicated by the mercury rising in the glass tube. When the bottles were opened, all except the sterilized uninoculated controls had about the same odor and taste as that of a normal silage. The contents of each bottle were put through a meat chopper to insure a uniform material, a sample was taken for the moisture determination, and as much juice expressed from the remainder as could be obtained with a strong hand press. This juice was analyzed for volatile and non-volatile acids by the usual methods; *viz.*, steam distillation for volatile acids and ether extraction of the residue from the steam distillation for non-volatile acids. The treatment of the corn fodder together with the results of the analyses is given in Table I.

An examination of the results of this table shows that in the unsterilized group there is a large production of acids and alcohol. A comparison of the products formed in the unsterilized silage with and without pentose fermenters added shows that the addition of these organisms caused a noticeable increase in volatile acid, non-volatile acid, and alcohol. These bacteria in the presence of the microorganisms commonly found in silage were able to bring about well defined differences in the chemical composition of silage.

In the sterilized group the action of these organisms is much more striking than in the raw and uninoculated group. In the absence of plant enzymes and microorganisms these bacteria brought about a decided increase in volatile and non-volatile

184 Pentose-Fermenting Bacteria and Silage

acid, and also produced a small amount of alcohol. When compared with the products naturally present in the sterilized, uninoculated silage, it is evident that the pentose-fermenting bacteria are very active in fermentation of sterilized corn fodder. It is of particular interest that these bacteria in the absence of other forms are able to produce in large amounts the chief substances which are characteristic of silage. From the data, it

TABLE I.
Analysis of Silage Formed from Corn with and without Inoculation.

Treatment.	100 gm. of dry silage.			
	Moisture.	Volatile acid as acetic.	Non-volatile acid as lactic.	Alcohol as ethyl alcohol.
	<i>per cent</i>	<i>gm.</i>	<i>gm.</i>	<i>gm.</i>
Untreated corn.	80.4	0.684	6.253	2.007
Unsterilized and inoculated with Culture 41-11.	81.1	1.502	7.357	2.631
Unsterilized and inoculated with Culture 118-S.	80.4	1.480	8.389	2.552
Sterilized control.	76.2	0.240*	1.999*	
" inoculated with Culture 41-11.	78.1	1.476	4.598	0.557
" " " " 118-S.	77.2	1.207	4.387	0.311
Sterilized control plus yeast water.	76.5	0.255	1.474	
" plus yeast water inoculated with Culture 41-11.	78.1	1.370	3.454	0.543
Sterilized, plus yeast water inoculated with Culture 118-S.	78.8	1.495	4.748	0.736

* These high values are no doubt due largely to chemical changes incident to the high temperature and length of time of sterilization.

appears that the pentose fermenters either in the presence or in the absence of other microorganisms are capable of bringing about an acid fermentation of silage which is comparable with that of normal silage.

From the data for the third group, sterilized corn plus yeast water and bacteria, it will be noted that the yeast water has little if any effect on fermentation.

On September 25, another series of bottles was set up in order to study the effect of inoculation by other acid-producing bacteria

as well as the pentose fermenters. The organisms chosen were *Bacillus lactis acidi* and *Bacillus bulgaricus*. The quantity of carbon dioxide produced by the pentose fermenters was determined in this series. This was absorbed in strong alkali and the latter analyzed by means of the Van Slyke apparatus for the determination of carbon dioxide in blood and in other carbonate solutions. The results are given in Table II.

TABLE II.

Effect of Inoculation with Different Types of Acid-Producing Bacteria.

Treatment.	100 gm. of dry silage.				
	Moisture.	Volatile acid as acetic.	Non-volatile acid as lactic.	Ethyl alcohol.	Carbon dioxide.
	<i>per cent</i>	<i>gm.</i>	<i>gm.</i>	<i>gm.</i>	<i>gm.</i>
Untreated corn.	74.6	2.436	2.844	0.908	Not determined.
Sterilized and uninoculated.	72.9	0.352	2.002	None.	“ “
Unsterilized and inoculated with <i>B. lactis acidi</i> .	67.0	1.033	2.862	0.966	“ “
Sterilized and inoculated with <i>B. lactis acidi</i> .	70.8	0.339	2.305	None.	“ “
Unsterilized and inoculated with <i>B. bulgaricus</i> .	70.3	1.231	3.007	“	“ “
Sterilized and inoculated with <i>B. bulgaricus</i> .	68.6	0.493	Lost.	“	“ “
Sterilized and inoculated with pentose fermenter No. 41-11.	71.9	1.562	3.801	0.568	0.876
Sterilized and inoculated with pentose fermenter No. 118-8.	73.0	1.335	3.475	Lost.	1.088

A study of the data of Table II clearly reveals the superiority of the pentose fermenters as compared with the other two types of bacteria in the formation of the substances usually found in silage. The latter produced little or no increase over the controls while the influence of the former is manifest in every case where they were present.

Carbon dioxide is shown to be produced by the pentose bacteria in large quantities but no comparison with the other organisms in this respect can be made as the quantity of gas evolved from these cultures was not determined.

SUMMARY.

The results of the experiments reported in this paper indicate that the pentose-fermenting bacteria are capable of bringing about decided changes in raw or in sterilized corn tissue. When added to raw corn fodder, these organisms are able to compete with the fermentation processes which normally occur. In sterilized silage the pentose fermenters develop rapidly and produce the substances commonly found in good silage; *viz.*, acetic acid, lactic acid, ethyl alcohol, and carbon dioxide.

From the standpoint of temperature, oxygen supply, and fermentable compounds, silage offers a suitable medium for the growth of the pentose fermenters. The authors feel that the results indicate that these bacteria play an important part in the formation of corn silage.

NOTE ON THE HYDROGEN ION CONCENTRATION OF THE HUMAN DUODENUM.

BY F. J. MYERS AND J. F. McCLENDON.

(From the Physiological Laboratory of the University of Minnesota Medical School, Minneapolis.)

(Received for publication, December 29, 1919.)

It has long been known that the stomach is acid in comparison to the ileum, and it follows from this that the reaction of the duodenum must be influenced by the opening of the pylorus. According to Cannon, the opening of the pylorus is controlled by the acidity of this region, but it has been shown by a number of workers, most recently by Luckhardt, Phillips, and Carlson, that the motor phenomena of the stomach have a great influence on the passage of its contents through the pylorus. Perhaps the following description is nearly correct: Acid influences the tone of the pylorus but whenever this is less than the tone of the stomach or duodenum the passage of fluid may occur. The passage must necessarily be toward the region of lesser tone and is not always in the same direction, as shown by the fact, known for a long time, that the stomach contents may occasionally be bile-stained. Since the chyme is acid and the pancreatic juice alkaline, the relative rate of the flow of these two into the duodenum must influence its reaction.

In 1915 Dr. John P. Schneider gave one of us two samples of human duodenal contents which were found to be of pH 1.5 and 7.61. He had been removing the duodenal contents from many of his patients with an Einhorn duodenal tube in order to estimate the bile pigments. He allowed the duodenal contents to syphon out of the tube and found that the flow was intermittent. Sometimes the fluid spurted out and it was then acid to litmus whereas otherwise it was not acid to litmus (paper). It was shown by McClendon that the duodenum of the infant, although always acid, was very variable, the reaction sometimes approach-

ing neutrality (pH = 6.3). Long and Fenger, using the duodenal tube, observed great variation in the adult duodenum (pH = 3.80 to 7.81). The technique used in the present paper differs from theirs only in the use of the hydrogen electrode described by McClendon and Magoon.

The Einhorn duodenal tube was swallowed by one of us (F.J.M.) and allowed to descend to the first mark, then carefully lowered to the second mark. The subject was then placed on his right side on a couch, with his hips elevated. An average of about 3.5 hours was required before the end of the tube with the lead

TABLE I.

Meal.	Food taken.	pH
Breakfast.	Hot cakes, toast, coffee.	3.80
"	Bacon, rice, coffee.	3.20
"	Corn flakes and cream, eggs, toast.	6.98
Luncheon.	Beef, potatoes, tomatoes, pie.	4.60
"	Pork, " eggplant, cake.	5.00
Breakfast.	Hot cakes, pineapple sauce, coffee.	7.21
"	Toast, raspberry sauce.	7.40
"	Ham, eggs, toast, coffee.	7.54
Luncheon.	Beef, potatoes, corn, ice-cream.	7.00
"	" " bread, melon, iced tea.	7.82
"	Potatoes, carrots, pie, cake, ice-cream, milk.	7.60
"*	Beef, onions, potatoes, pie, cake followed by bismuth.	7.54

* The fluoroscope was used in conjunction with bismuth and the duodenal tube after the digestion of the food was well under way.

weight seemed to be in the duodenum. The degree of traction on the tube was at first used as an index of its passage of the pylorus, but since some of the samples were acid we began to doubt that the pylorus had been passed, and confirmed this by use of the fluoroscope, for which our thanks are due the University Hospital.

In Table I the determinations that were acid and those that were alkaline are separated for comparison. We have no doubts that the acid samples came from the duodenum, since all samples were taken about 3 or 4 hours after the last meal and it has been shown by McClendon that the pH of the stomach at this time was between 1 and 2.5 in all normal individuals examined, whereas

the acid samples reported in Table I have a pH between 3.2 and 6.98.

After the position of the lead weight on the end of the duodenal tube in the duodenum was shown by means of the fluoroscope, it

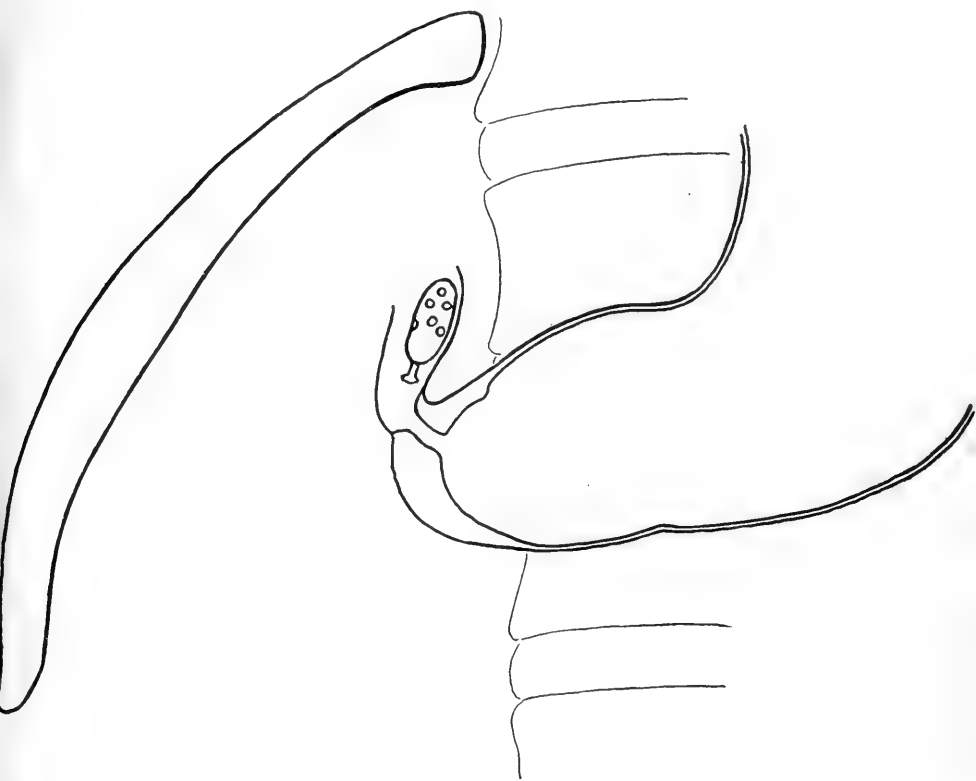

FIG. 1.

was drawn down toward the pylorus by traction on the tube and a photograph taken. A tracing from the x-ray plate is shown in Fig. 1. The dim edges of shadows in the plate were sharpened by free-hand drawing in making the tracing.

CONCLUSIONS.

The reaction of the duodenum between 3 and 4 hours after meals was usually found to fluctuate around the neutral point, but the extreme range on the acid side was greater than on the alkaline side, possibly due to the spurting of gastric contents into the duodenum.

BIBLIOGRAPHY.

- Cannon, W. B., *Am. J. Physiol.*, 1907-08, xx, 283.
Long, J. H., and Fenger, F., *J. Am. Chem. Soc.*, 1917, xxxix, 1278.
Luckhardt, A. B., Phillips, H. T., and Carlson, A. J., *Am. J. Physiol.*, 1919, 1, 57.
McClendon, J. F., *Am. J. Physiol.*, 1915, xxxviii, 191.
McClendon, J. F., and Magoon, C. A., *J. Biol. Chem.*, 1916, xxv, 669.

STUDIES OF ACIDOSIS.

XV. CARBON DIOXIDE CONTENT AND CAPACITY IN ARTERIAL AND VENOUS BLOOD PLASMA.

By WILLIAM C. STADIE AND DONALD D. VAN SLYKE.

(From the Hospital of The Rockefeller Institute for Medical Research.)

(Received for publication, December 29, 1919.)

According to the facts at our disposal, the bicarbonate content of the arterial blood plasma appears to be the blood figure most accurately indicating the alkaline reserve of the body fluids as a whole (Van Slyke and Cullen, 1917; Palmer and VanSlyke, 1917). In man it has heretofore been necessary to depend upon bicarbonate determinations in the venous blood as the closest practicable approximation to the arterial bicarbonate. In practice this has been estimated by determining the carbon dioxide capacity; that is, the CO_2 content of the plasma after saturation with air containing CO_2 at approximately the tension of normal alveolar air (Van Slyke and Cullen, 1917). The reliability of such determinations for the diagnosis of acidosis in metabolic diseases may be considered as demonstrated by the tests to which the method has been put in various laboratories, but it nevertheless remains desirable to compare the results thus obtained on the venous plasma with the actual arterial bicarbonate. The utilization of a technique for arterial punctures (Stadie, 1919) has rendered it possible to make this comparison in a series of patients, and the results are presented in this paper. Altogether thirty individuals were studied, most of whom had bronchopneumonia or lobar pneumonia of varying degrees of severity. A few normal individuals are included.

Methods.

The arterial blood was obtained as previously outlined (Stadie, 1919). The venous blood was taken without stasis, and, as a rule, 1 to 3 minutes after the arterial; both arterial and venous bloods were collected out of contact with air under albolene.

The CO_2 content and capacity were determined by the methods of Van Slyke (1917) and Van Slyke and Cullen (1917) respectively. The blood, collected under albolene to prevent loss or gain of CO_2 , was centrifuged, and 1 cc. samples of the plasma were withdrawn and discharged into the cup of the Van Slyke apparatus under a little ammonia to prevent escape of CO_2 . After thus determining the CO_2 content, the remaining plasma was saturated with air containing approximately 5.5 volumes per cent of CO_2 , and the CO_2 capacity then determined.

In calculating CO_2 capacity (by Table I, Van Slyke and Cullen, 1917) the CO_2 physically dissolved (H_2CO_3) is subtracted, so that the results represent only CO_2 bound as bicarbonate.

In calculating the CO_2 content, however (by Table I, Van Slyke, 1917), no subtraction for physically dissolved CO_2 is made, and the data represent total CO_2 from NaHCO_3 and H_2CO_3 together. The free CO_2 in normal arterial plasma is about 3 volumes per cent; that is, a CO_2 content of 65 volumes per cent represents approximately 62 volumes per cent of bicarbonate CO_2 and 3 volumes per cent of free carbonic acid CO_2 .

The arterial oxygen unsaturation, or the percentage of hemoglobin in the arterial blood not combined with oxygen, was calculated as described by Lundsgaard (1918) using Van Slyke's method (1918) for the oxygen determinations. The oxygen content of the arterial blood was determined, and then a portion was thoroughly aerated, and the oxygen capacity determined.

$$\text{Per cent oxygen unsaturation} = \frac{\text{O}_2 \text{ capacity} - \text{O}_2 \text{ content}}{\text{O}_2 \text{ capacity}} \times 100.$$

In normal individuals at rest the arterial unsaturation averages about 5 per cent, 95 per cent of the hemoglobin in the arterial blood being saturated with oxygen. Figures for the unsaturation higher than 8 per cent indicate incomplete oxygenation of the arterial blood.

The results are given in Table I. In a few cases the arterial CO_2 content equals or slightly exceeds the venous. This may have been due to the short differences in time between the drawing of arterial and venous bloods, or to a summation of experimental errors in the two determinations. The latter factor cannot be excluded because in many cases the amount of material did not permit analyses in duplicate. It is believed,

TABLE I.

Case No.	Arterial plasma.		Venous plasma.		A	B	C	Arterial oxygen unsaturation.
	CO ₂ content.	CO ₂ capacity.	CO ₂ content.	CO ₂ capacity.	Arterial content	Arterial content	Arterial content	
	<i>vol. per cent</i>	<i>vol. per cent</i>	<i>vol. per cent</i>	<i>vol. per cent</i>	Arterial capacity	Venous capacity	Venous content	
3		60.3		60.3				11.9
	65.7	67.2	66.6	70.0	0.978	0.939	0.988	9.0
	69.9		74.6	75.8		0.922	0.937	6.0
	70.8	72.9	71.1	72.9	0.971	0.971	0.996	0
6	65.2		71.8	69.2		0.942	0.942	
8			67.3	73.7				8.1
9	50.3	56.8	50.8	54.9	0.886	0.916	0.990	68.2
10	69.0	73.0	68.4	71.6	0.945	0.964	1.009	4.6
11	57.3	62.4	59.2	64.9	0.918	0.883	0.968	10.1
12	62.6	67.5	66.0	68.9	0.928	0.909	0.948	8.9
	59.5	66.5	63.8	69.4	0.895	0.857	0.933	6.3
13	56.2	61.7	60.1	64.6	0.911	0.870	0.935	13.7
	63.5	66.2	62.5	66.2	0.959	0.959	1.016	2.8
14	61.9	62.1	64.7	65.0	0.997	0.952	0.957	7.5
	63.2	70.0			0.903			20.7
15	55.5	62.3	60.9	66.3	0.891	0.837	0.911	7.8
	63.1	65.3	67.4	69.1	0.966	0.913	0.936	7.3
16	55.8	59.4	59.7	66.7	0.939	0.837	0.935	14.1
17	59.6	62.2	60.5	62.2	0.958	0.958	0.985	16.3
	69.1	71.6	77.6	78.1	0.965	0.885	0.891	11.5
18	56.0	63.3	57.8	63.3	0.885	0.885	0.969	16.6
	61.4	64.0	59.0	64.0	0.959	0.960	1.041	16.5
19			63.1	70.8				38.2
	63.9	68.4	65.8	68.4	0.934	0.934	0.971	7.9
	57.1	76.5	61.8	76.0	0.746	0.751	0.924	0
20	55.7	62.0		61.1	0.898	0.912		13.4
22	63.3	70.8	71.1	75.5	0.894	0.838	0.891	19.5
	46.8	51.9	51.5	50.0	0.902	0.936	0.909	25.1
23	66.8	62.1	69.7	69.6	1.076	0.960	0.959	15.1
			67.2	78.1				8.9
24	64.5	66.2	71.2	68.1	0.974	0.947	0.906	2.4
25			54.9	50.9				44.1
26	63.7		71.9				0.886	5.2
30	50.2	52.6	57.3	65.8	0.954	0.763	0.876	24.9
33	55.5	60.0	58.4	57.2	0.925	0.970	0.950	23.4
34	58.8	61.4			0.958			14.9
	53.3	57.2	53.3	59.2	0.932	0.900	1.000	33.5
	56.7	58.8			0.964			25.9
38	56.1	57.8			0.971			10.7
	56.2		60.6	63.2		0.889	0.927	8.4
	57.4	61.0	59.3	66.8	0.941	0.859	0.968	14.5
40	59.8	59.5			1.005			
41	55.7	61.0			0.913			
42	50.8	51.4			0.988			
Average.....					0.938	0.904	0.950	

however, that the number of determinations is sufficient to rule out the influence of such factors on the results viewed as a whole. The latter seem to justify the following conclusions.

CONCLUSIONS.

1. The carbon dioxide capacity (NaHCO_3) of the venous blood plasma in man determined by the technique of Van Slyke and Cullen (1917) parallels the arterial plasma carbon dioxide content ($\text{NaHCO}_3 + \text{H}_2\text{CO}_3$), which it exceeds on the average by about one-tenth. As the arterial CO_2 is 95 per cent due to bicarbonate, the above results mean that the venous plasma carbon dioxide capacity parallels the arterial plasma bicarbonate, averaging about 115 per cent as great (Column B of Table I).

2. The carbon dioxide *content* of plasma from venous blood drawn without stasis parallels the arterial slightly more closely than does the venous carbon dioxide capacity and averages 105 per cent of the arterial content (Column C).

3. Consequently, for estimating the alkaline reserve in man, the venous plasma may be used for CO_2 determination directly, without resaturation with carbon dioxide, if the blood is centrifuged and the plasma brought to analysis without opportunity for escape of CO_2 .

4. Even when pulmonary conditions in pneumonia become so unfavorable for gasexchange that the arterial blood is incompletely oxygenated (high oxygen unsaturation), the arterial and venous carbon dioxide values are not increased above the usual normal levels. This might be expected from the fact shown by Krogh and Krogh (1910) that the lungs maintain approximate equality of carbon dioxide tension between arterial blood and alveolar air much more readily than they maintain equality of oxygen tension.

BIBLIOGRAPHY.

- Krogh, A., and Krogh, M., *Skand. Arch. Physiol.*, 1910, xxiii, 179.
Lundsgaard, C., *J. Biol. Chem.*, 1918, xxxiii, 133.
Palmer, W. W., and Van Slyke, D. D., *J. Biol. Chem.*, 1917, xxxii, 499.
Stadie, W. C., *J. Exp. Med.*, 1919, xxx, 215.
Van Slyke, D. D., *J. Biol. Chem.*, 1917, xxx, 347.
Van Slyke, D. D., *J. Biol. Chem.*, 1918, xxxiii, 127.
Van Slyke, D. D., and Cullen, G. E., *J. Biol. Chem.*, 1917, xxx, 289.

EFFECT OF CALCIUM ON THE COMPOSITION OF THE EGGS AND CARCASS OF LAYING HENS.

BY G. DAVIS BUCKNER AND J. H. MARTIN.

(From the Kentucky Agricultural Experiment Station, Lexington.)

(Received for publication, December 4, 1919.)

In connection with certain studies concerning the growth of the White Leghorn hen, an experiment was planned to determine the effect produced by grit, oyster shell, and limestone on the composition of the eggs laid when fed in connection with an ordinary ration used for laying hens; and also to determine what would be the ultimate effect on the body of the hens of the continued laying of eggs in the absence of calcium other than that contained in the food. In other words, it was proposed to determine the composition of eggs of hens whose supply of calcium was limited to that contained in a dry mash and mixed grains (having a low calcium content) as compared with the composition of the eggs from hens receiving all the calcium they might desire from oyster shell and ground limestone. It also seemed important to determine to what degree the continued laying of eggs, on a limited intake of calcium, would lower the calcium content of the carcass of the hen before she should stop laying. The corresponding distribution of magnesium and phosphorus was also to be determined.

With these ends in view, forty pure bred, White Leghorn pullets were selected from the same incubator hatching and divided into four lots of ten each, having approximately the same development and vigor. These were placed in four separate hen houses which were identical in every way, and during the entire experiment the pullets were not allowed access to the ground, thus eliminating any possible chance of their obtaining inorganic material from undesired sources. These lots were designated Nos. 1, 2, 3, and 4 and all received the same ration; namely, a dry mash composed of 6 parts corn-meal, 3 parts bran, 3 parts middlings,

196 Calcium of Eggs and Carcass of Laying Hens

5 parts meat meal, and 5 parts charcoal; and a grain mixture of 16 parts wheat, 16 parts cracked corn, and 8 parts oats. These foods were supplemented in Pen 2 with grit, in No. 3 with grit and oyster shell, and in No. 4 with grit and limestone; whereas Pen 1 received no additional mineral matter. The percentages of calcium, magnesium, and phosphorus in the foods and the supplemental mineral material are given in Table I, calculated as the oxides.

At the beginning of the experiment, December 1, 1918, separate analyses were made of the shell and of the contents of an average egg. Also a representative pullet was killed and the head, skin, feathers, feet, and intestines with the contents of the gizzard were discarded, to eliminate any extraneous matter. The two large upper bones (femur and tibia) of both legs were dissected

TABLE I.
Analysis of the Materials Fed.

Material.	Crude ash.	Calcium oxide (CaO).	Magnesium oxide (MgO).	Phosphorus pentoxide (P ₂ O ₅).
	<i>per cent</i>	<i>per cent</i>	<i>per cent</i>	<i>per cent</i>
Grain mixture.....	2.37	0.0013	0.0006	0.0078
Mash ".....	7.75	0.0192	0.0024	0.0182
Grit.....		1.00	0.82	0.09
Oyster shell.....		51.85	0.37	0.12
Limestone.....		47.95	1.00	0.18

out and, after being freed from adhering material, were analyzed separately from the remaining part of the carcass. During the progress of the experiment, when marked visible changes appeared in the hens, an egg was obtained on the same day from each of the four lots and, after being carefully cleaned with distilled water, the shells and their contents were separately analyzed for calcium, magnesium, and phosphorus. Also, whenever a hen broke down, she was killed and analyzed as stated above.

As the experiment advanced it was noticed that the general condition of Lots 1 and 2 was not so good as that of Lots 3 and 4 which received the calcium supplement. It will be seen in Table II that deaths occurred in each lot except Lot 3; they occurred from various causes which are not of such a character as would result directly from lack of proper nourishment. In Lot 1 there

was no instance of a complete breakdown similar to those that occurred in Lot 2 on March 9th and May 20th. It seems most probable that this breaking down in Lot 2 was due to individual weakness rather than to the grit supplementing their ration, which was the only point in which the ration differed from that of Lot 1. The average number of eggs laid per hen, per month, was approximately the same in Lots 1 and 2, while in Lot 4 the average was 13.5 per cent greater than that of Lot 3, which may or may not be attributed to individual variation.

In all lots, March and April seem to be the periods of greatest average egg production and while this production was less in all

TABLE II.
Mortality and Egg Record.

Lot No.	December.		January.		February.		March.		April.		May.		Average No. of eggs per hen.				
	No. of hens.	Total eggs. No. of eggs per hen.	No. of hens.	Total eggs. No. of eggs per hen.	No. of hens.	Total eggs. No. of eggs per hen.	No. of hens.	Total eggs. No. of eggs per hen.	No. of hens.	Total eggs. No. of eggs per hen.	No. of hens.	Total eggs. No. of eggs per hen.		Total eggs laid in 6 months.			
1	10	00	10	16 1.6	10	54 5.4	9*	80	8.9	9	120	13.3	9	21	2.3	291	31.5
2	10	20.2	9†	27 3.0	8†	51 6.4	7‡	71	10.1	7	41	5.8	7	37	5.3	229	30.6
3	10	00	10	20 2.0	10	86 8.6	10	171	17.1	10	122	12.2	10	89	8.9	488	48.8
4	10	30.3	10	43 4.3	9*	73 8.1	9	143	15.9	9	137	15.2	8*	102	12.8	491	56.4

* Cause of death unknown.

† Death caused by chicken pox.

‡ This hen was killed after breaking down and was analyzed; see Table V.

lots during the month of May than it was in March or April, yet it can plainly be seen that the lack of mineral matter increased the difference.

As will be seen in Tables III and IV, which give the analyses of the egg shells and their contents, an egg was analyzed December 1, which marked the starting of the experiment, and on February 12, or approximately 10 weeks later, an egg was analyzed from each lot, since it was noticed at this time that the general appearance of Lots 1 and 2 did not equal that of Lots 3 and 4. This difference became more exaggerated as time passed until, on March 8th, a hen in Lot 2 broke down. She was unsteady and remained in a squatting position, unless disturbed. On the day

198 Calcium of Eggs and Carcass of Laying Hens

following, the hen could not stand and, since her appetite was practically gone, she was killed and analyzed as described elsewhere. The results of these analyses are shown in Table V. At this point an egg was obtained from each lot and analyzed.

TABLE III.
Analyses of Shells of Eggs from All Lots.

Date.	Lot No.	Total shell.		Total ash.		Calcium, as CaO, in ash.		Magnesium, as MgO, in ash.		Phosphorus, as P ₂ O ₅ , in ash.	
		gm.	per cent	gm.	per cent	gm.	per cent	gm.	per cent	gm.	per cent
Dec. 1, 1918	Normal.	4.702	58.55	2.753	58.55	2.720	98.10	0.019	0.71	0.019	0.70
Feb. 12, 1919	1	5.129	57.13	2.930	57.13	2.850	97.25	0.018	0.62	0.020	0.69
	2	4.660	55.47	2.586	55.47	2.525	97.65	0.016	0.62	0.013	0.51
	3	5.742	53.69	3.083	53.69	3.030	97.30	0.023	0.77	0.020	0.65
	4	5.853	54.53	3.191	54.53	3.129	98.05	0.019	0.61	0.023	0.74
Mar. 8, "	1	4.685	54.25	2.541	54.25	2.475	97.40	0.018	0.74	0.015	0.59
	2	3.910	54.20	2.119	54.20	2.093	98.80	0.012	0.61	0.011	0.54
	3	5.725	55.41	3.172	55.41	3.123	98.45	0.019	0.63	0.012	0.40
	4	4.563	55.28	2.522	55.28	2.482	98.40	0.013	0.54	0.018	0.73
" 22, "	1	3.608	53.61	1.934	53.61	1.895	98.00	0.013	0.72	0.012	0.67
	2	3.775	53.92	2.035	53.92	1.986	97.95	0.017	0.87	0.011	0.57
	3	5.879	54.82	3.222	54.82	3.164	98.20	Lost.	Lost.	0.013	0.41
	4	5.903	54.03	3.189	54.03	3.119	97.80	0.024	0.76	0.022	0.70
May 20, "	1	*									
	2	3.050	52.61	1.604	52.61	1.577	98.30	0.013	0.81	0.009	0.62
	3	4.664	56.12	2.497	56.12	2.447	98.00	0.022	0.89	0.015	0.60
	4	5.269	56.11	2.956	56.11	2.885	97.60	0.027	0.93	0.028	0.97
June 1, "	1	2.949	53.03	1.564	53.03	1.524	97.50	0.013	0.89	0.009	0.60
	2	2.797	55.14	1.542	55.14	1.500	97.20	0.015	1.03	0.013	0.86
	3	3.233	60.46	1.954	60.46	1.918	98.15	0.015	0.80	0.017	0.90
	4	4.320	58.32	2.519	58.32	2.471	98.10	0.022	0.90	0.016	0.65

* The shell of the egg obtained from Lot 1 on May 20 was so thin that it broke in handling.

On March 22, May 20, and June 1 an egg was obtained from each lot and analyzed and, since, on June 1, the hens in Lots 1 and 2 were in a state bordering on a general breakdown and had practically ceased laying eggs, the experiment was brought to a

close and an average hen from each lot was killed and analyzed. In Table VI will be found the analyses of the carcasses and leg bones of hens from each of the four lots, made 6 months after the start of the experiment.

TABLE IV.

Analyses of the Contents of Eggs from All Lots.

Date.	Lot No.	Total con- tents.		Total ash.		Calcium, as CaO, in ash.		Magnesium, as MgO, in ash.		Phosphorus, as P ₂ O ₅ , in ash.	
		gm.	gm.	per cent	gm.	per cent	gm.	per cent	gm.	per cent	
Dec. 1, 1918	Normal.	43.216	0.410	0.95	0.033	8.12	0.006	1.46	0.164	40.05	
Feb. 12, 1919	1	44.095	0.423	0.96	0.034	8.05	0.005	1.38	0.157	37.20	
	2	41.711	0.354	0.85	0.030	8.31	0.005	1.58	0.155	44.00	
	3	47.022	0.456	0.97	0.038	8.50	0.007	1.57	0.181	39.77	
	4	39.612	0.380	0.96	0.032	8.55	0.005	1.33	0.161	42.40	
Mar. 8, "	1	49.702	0.412	0.83	0.030	7.44	0.006	1.45	0.164	39.71	
	2	52.110	0.437	0.84	0.035	8.04	0.004	1.78	0.144	33.00	
	3	44.201	0.419	0.95	0.033	7.93	0.004	1.13	0.184	44.04	
	4	42.846	0.372	0.87	0.028	7.51	0.005	1.34	0.164	44.11	
" 22, "	1	37.800	0.378	1.00	0.030	7.98	0.004	1.12	0.141	37.51	
	2	44.315	0.398	0.90	0.025	6.45	0.003	0.81	0.148	37.31	
	3	52.080	0.479	0.92	0.039	8.34	0.005	1.22	0.194	40.50	
	4	52.413	0.487	0.93	0.038	8.05	0.004	0.87	Lost.	Lost.	
May 20, "	1	*									
	2	39.788	0.338	0.85	0.023	6.86	0.005	1.52	0.125	37.20	
	3	45.042	0.427	0.95	0.035	8.32	0.005	1.37	0.206	48.20	
	4	44.215	0.415	0.97	0.034	8.31	0.004	1.12	0.206	49.60	
June 1, "	1	37.161	0.308	0.83	0.020	6.50	0.003	1.14	0.121	39.50	
	2	35.083	0.287	0.82	0.021	8.10	0.003	1.06	0.113	46.00	
	3	37.521	0.352	0.94	0.037	10.80	0.004	1.40	0.162	46.10	
	4	51.019	0.474	0.93	0.033	7.19	0.005	1.09	0.233	49.20	

* The shell of the egg obtained from Lot 1 on May 20th was so thin that it broke in handling.

In analyzing the separate portions of the ash of the materials under consideration, the phosphorus was determined by the method of the Association of Official Agricultural Chemists,¹

¹Wiley, H. W., Official and provisional methods of analysis, U. S. Dept. Agric., Bureau of Chemistry, Bull. 107, revised, 1912.

200 Calcium of Eggs and Carcass of Laying Hens

TABLE V.
Analyses of Normal Hen and a Hen That Had Broken Down in Lot 2.

Date.	Lot No.	Part analyzed.	Total weight of part analyzed.		Total ash.		Calcium, as CaO, in ash.		Magnesium, as MgO, in ash.		Phosphorus, as P ₂ O ₅ , in ash.	
			gm.	per cent	gm.	per cent	gm.	per cent	gm.	per cent	gm.	per cent
Dec. 1, 1918	Normal.	Carcass. 4 leg bones.	727.00	2.79	20.305	2.79	7.563	37.25	0.213	1.05	7.750	38.17
	"		24.34	29.70	7.235	29.70	3.766	52.05	0.048	0.07	2.841	39.27
Total.....			751.34		27.540		11.329		0.261		10.591	
Mar. 9, 1919	Broken down in Lot 2.	Carcass. 4 leg bones.	513.50	2.91	14.934	2.91	5.354	35.85	0.158	1.06	6.318	42.31
			19.05	19.86	3.783	19.86	1.920	50.75	0.024	0.64	1.494	39.50
Total.....			532.55		18.717		7.274		0.182		7.812	

TABLE VI.
Analyses of Carcasses and Leg Bones of Hens from All Lots, at the End of the Experiment, June 1, 1919.

Date.	Lot No.	Part analyzed.	Total weight of part analyzed.	Total ash.		Calcium, as CaO, in ash.		Magnesium, as MgO, in ash.		Phosphorus, as P ₂ O ₅ , in ash.	
				gm.	per cent	gm.	per cent	gm.	per cent	gm.	per cent
June 1, 1919	1	Carcass.	629.00	23.269	3.69	7.213	31.00	0.235	1.01	7.574	32.55
			32.00	8.586	26.83	4.602	53.60	0.059	0.69	3.484	40.58
	Total.....	661.00	31.855		11.815			0.294		11.058	
	2	Carcass.	552.00	15.274	2.76	4.643	30.4	0.139	0.91	4.803	31.45
			24.90	4.509	18.10	2.371	52.6	0.025	0.57	1.739	38.58
	Total.....	576.90	19.783		7.014			0.164		6.543	
	3	Carcass.	836.00	27.020	3.23	10.470	38.75	0.375	1.38	10.851	40.16
			33.00	11.338	34.36	6.240	55.04	0.329	2.91	4.382	38.66
	Total.....	869.00	38.358		16.710			0.704		15.233	
	4	Carcass.	731.00	26.400	3.61	9.570	36.25	0.398	1.51	9.240	35.00
			32.00	8.005	25.02	4.419	55.20	0.249	3.11	3.216	40.18
	Total.....	763.00	34.405		13.989			0.647		12.456	

while calcium and magnesium were determined according to the method of McCrudden.²

From Tables III and IV it will be seen that there is little variation in the percentages of ash, calcium, magnesium, and phosphorus in the egg shells and the contents of the eggs in all four lots during the 6 months over which the experiment lasted. However, there was a decided tendency in Lots 1 and 2 for the total weights of the shell to become smaller as the experiment advanced; in other words, the shell became progressively thinner. On May 20 the shell of the egg obtained from Lot 1 was so thin that it broke in handling and was lost. In the case of Lots 1 and 2, on June 1, the eggs were handled in cotton-padded boxes, to prevent breaking. In no case was a shell-less egg obtained from these four lots.

In Table V we see that the total weight of the parts of the hen which broke down on March 9 was 218.79 gm. less than the normal hen that was over 3 months younger. One of the most interesting points in the comparison of the analyses of these two hens is the great difference in the percentage of ash, while there is practically no difference in the percentage of calcium, magnesium, and phosphorus in the ash. In other words, there seems to be a stable equilibrium in this connection which exists even though there is a marked difference in the total quantity. As will be seen in Table VI, magnesium fails to adhere to this rule.

In Table VI the comparative analyses of the carcasses and leg bones of hens from Lots 1, 2, 3, and 4 show that the hens of Lots 1 and 2 weigh appreciably less than those of Lots 3 and 4 and that there is a general depletion of the quantities of ash, calcium, magnesium, and phosphorus in Lots 1 and 2.

It would seem from a study of the foregoing figures that the following conclusions are justified.

1. Laying hens whose supply of calcium is limited to that naturally occurring in the food will continue laying eggs until there is a general depletion of magnesium, phosphorus, and calcium in their bones and carcasses.

² McCrudden, F. H., The quantitative separation of calcium and magnesium in the presence of phosphates and small amounts of iron devised especially for the analysis of foods, urine and feces, *J. Biol. Chem.*, 1909-10, vii, 83.

2. As long as the economy of the hens permitted the formation of an egg shell, the contents of the egg remained reasonably constant, thereby permitting an average supply of calcium, magnesium, and phosphorus for the proper development of the embryo of the chick.

3. 10 weeks elapse before there is a noticeable change in the general condition of hens receiving no mineral matter other than that naturally occurring in the food such as that fed to Lots 1 and 2.

4. It would seem most probable that the breaking down of certain hens before the expiration of 6 months was caused by individual weakness.

5. Since no shell-less eggs were laid in Lots 1 and 2, it would indicate that the lack of calcium is not the fundamental cause of their formation.

6. The percentages of calcium and of phosphorus in the bones of the hens in all lots were reasonably constant during this experiment, thus indicating a stable equilibrium between the two elements.

7. The continued laying of eggs, under the calcium restrictions of this experiment, does not materially alter the percentage mineral composition of the egg shells or their contents. There is, however, a gradual thinning of the egg shells.

8. Under the conditions governing this experiment, the addition of limestone or oyster shell to the ration increases the production of eggs 69.4 per cent as shown by the average egg production of Lots 1 and 2 when compared with that of Lots 3 and 4.

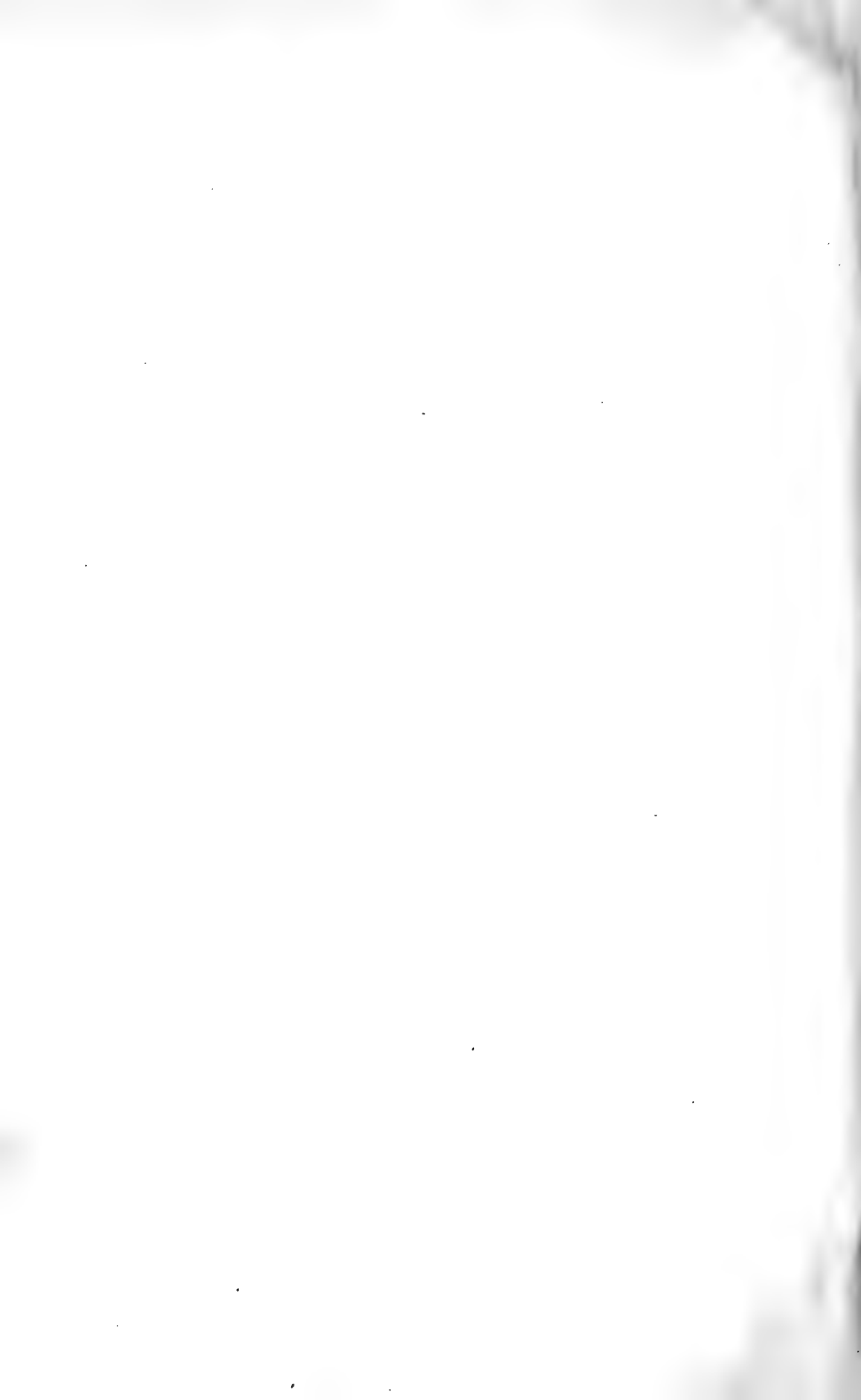

NOTE ON A SHORT MODIFICATION OF THE OFFICIAL CHLORINE METHOD FOR FEEDS, FECES, AND URINE.

BY J. O. HALVERSON AND E. B. WELLS.

(From the Department of Nutrition, Ohio Agricultural Experiment Station, Wooster.)

(Received for publication, December 29, 1919.)

The determination of chlorine in blood or body fluids has resulted in a modification of the Volhard method by Rappleye¹ and in the development of an iodometric method by McLean and Van Slyke² both of which aim to give better and more distinct end-points than the above official method³ and therefore more accurate results.

The concentration of the NaCl estimated by them in blood involved a magnitude of 400 to 600 mg. per 100 cc. of liquid. The magnitude of chlorine estimated in feeds, feces, and swine urine is less than 100 mg., consisting respectively of 39, 19, and 104 mg. or the actual amount estimated per determination was 3.8, 3.6, and 14.0 mg. The estimation of such small quantities by the official Volhard method as usually done does not give as consistent results as desired.⁴

This is chiefly because of the volumetric strength of the reagents employed, the indefiniteness of the end-point in titration, and the difficulty of washing out excess AgNO₃ from the precipitated AgCl without obtaining a slightly turbid filtrate which renders the end-point less distinct. The process of washing the excess AgNO₃ out is also long and tedious resulting in a bulky filtrate which gives a less distinct end-point.

¹ Rappleye, W. C., *J. Biol. Chem.*, 1918, xxxv, 509.

² McLean, F. C., and Van Slyke, D. D., *J. Biol. Chem.*, 1915, xxi, 361.

³ *J. Assn. Offic. Agric. Chem.*, 1915-16, i, p. xxxii.

⁴ Halverson, J. O., and Schulz, J. A., *J. Am. Chem. Soc.*, 1919, xli, 440.

For these reasons the modification given below was adopted. This consisted in eliminating the step of washing excess AgNO_3 out from the AgCl precipitate and substituting titration of an aliquot of the clear filtrate directly after filtering off the AgCl precipitate. This procedure gives the same results as the official method when the latter is refined by using weaker reagents of AgNO_3 and of NH_4CNS , and using a burette with the latter reading to 0.05 cc. in which the NH_4CNS is capable of being estimated to 0.01 cc. Further, a definite smaller volume of solution is always titrated.

The Proposed Modification.

After the digestion of the alkaline ash with dilute nitric acid the solution is filtered into a beaker and the residue washed with hot water to a total volume not exceeding 75 cc. To the boiling solution on the hot plate is gradually added 0.05 N AgNO_3 , chlorine being slowly precipitated. The volume is then reduced to 25 or 30 cc. by boiling which allows the precipitate to coagulate and gives a perfectly clear solution. The solution is allowed to cool, when it is carefully transferred to a 100 cc. volumetric flask, made up to mark, and is then gently mixed by inverting the flask several times. Let stand 3 to 4 hours or, if convenient, over night thus allowing the precipitate to settle. Filter through a dry filter paper into a dry beaker. Pipette out 95 cc. into a 200 cc. Erlenmeyer flask.⁵ Add 2 cc. of ferric nitrate indicator,⁶ titrate the excess AgNO_3 with NH_4CNS , which is one-half the strength of the AgNO_3 ,⁷ against a white background using a burette reading to 0.05 cc. and capable of being estimated to 0.01 cc.

The number of cc. of NH_4CNS used, increased by $\frac{100}{95}$, gives the equivalent cc. for the total charge taken. Cc. of AgNO_3 —
 (cc. of $\text{NH}_4\text{CNS} \times \frac{100}{95} \times \text{factor}) = \text{cc. of } \text{AgNO}_3 \text{ used.}$

⁵ A 47.5 cc. pipette is conveniently used here.

⁶ 125 cc. of concentrated nitric acid are added to 325 cc. of water; boiled until colorless. 50 cc. of a saturated solution of ferric nitrate are added.

⁷ 0.05 N AgNO_3 is used; 1 cc. is approximately equivalent to 1.5 mg. of chlorine.

In Table I are given results by the refined official Volhard method and also with the proposed modification included. It is seen that the small differences, part of a milligram, per 100 gm. or per 100 cc. are of the same order of magnitude as obtained by McLean and Van Slyke.²

TABLE I.

*Comparison of the Modified Chlorine Method with the Official Chlorine (Volhard) Method.**

Material tested.	Quantity taken.	Chlorine by official method.†		Quantity taken.	Chlorine by modified method.		Difference per 100 gm. or cc.
		Found.	Per 100 gm. or cc.		Found.	Per 100 gm. or cc.	
		mg.	mg.		mg.	mg.	mg.
Corn.....	10.00 gm.	3.99	39.9	10.00 gm.	4.08	40.8	0.9
Linseed oil meal.....	10.00 "	3.82	38.2	10.00 "	3.89	38.9	0.7
Wheat middlings.....	10.00 "	3.61	36.1	10.00 "	3.69	36.9	0.8
Swine feces 1.....	18.00 "	3.84	21.3	16.97 "	3.65	21.5	0.2
" " 2.....	18.09 "	3.24	17.9	18.31 "	3.47	18.9	1.0
" " 3.....	17.95 "	3.06	17.0	17.64 "	3.09	17.5	0.5
" " 4.....	18.04 "	3.74	20.7	18.61 "	3.96	21.3	0.4
" urine 5.....	10.00 cc.	9.49	94.9	10.00 cc.	9.43	94.3	0.6
" " 6.....	10.00 "	9.13	91.3	10.00 "	9.22	92.2	0.9
" " 7.....	10.00 "	12.10	121.0	10.00 "	12.18	121.8	0.8
" " 8.....	10.00 "	10.70	107.0	10.00 "	10.74	107.4	0.4

* All samples were done in triplicate. Averages are given.

† 1 cc. of AgNO_3 was equivalent to 1.492 mg. of chlorine while the ratio for NH_4CNS was 1.2755; the ratio of NH_4CNS for the modified method was 0.5076.

Both the official Volhard and the modified method were checked against salts of known chlorine content, also against dried c. p. NaCl . The proposed method varied from a few hundredths to 0.6 or 0.7 per cent while the official Volhard method by the usual procedure varied 1 to 2 per cent from theory.

By this method clear solutions of small definite volumes for titration are obtained thus avoiding the frequent turbidity encountered and the tedious washing of the AgCl precipitate free from the excess AgNO_3 .

The authors wish to thank Dr. E. B. Forbes for courtesies rendered.

A COMPARATIVE STUDY OF HEMOGLOBIN DETERMINATION BY VARIOUS METHODS.

By FRIEDA S. ROBSCHEIT.

(From the George Williams Hooper Foundation for Medical Research, University of California Medical School, San Francisco.)

(Received for publication, November 3, 1919.)

The regeneration of hemoglobin and red cells following simple anemia has been studied in this laboratory for more than 2 years. A preliminary report of this work by Whipple and Hooper (13) has appeared and it is obvious that this curve of hemoglobin regeneration can be influenced by a number of diet factors. In this work it is essential that there be an accurate determination of hemoglobin. For this reason a comparative study of many hemoglobin methods was undertaken. It is believed that the method finally adopted for this work will be of value to other workers in the experimental field as well as to hospital and school laboratories where routine hemoglobin readings are so frequent. It need not be stated that much of the work expended upon routine hemoglobin determination is a total loss because the instrument used has not been standardized or the method is inaccurate. Too little is known as to the normal hemoglobin value in human beings as affected by age, altitude, climate, etc. No comparison is possible until some accurate standard is adopted for the routine work.

The earlier anemia work in this laboratory was done with Sahli's method using his modification of Gowers' instrument. It was soon apparent that incorrect results were being obtained and that the hemoglobin percentages were considerably higher than they should be when correlated with the other blood findings. The standard color tubes when checked against the oxygen capacity method of Van Slyke (12) showed great variations in color density. New tubes were purchased and when standardized showed much fading varying from 5 to 20 per cent. The

results obtained with these tubes were therefore sufficiently erroneous to warrant the discarding of this method for hemoglobin determination.

The Palmer carbon monoxide method was next tested and accurate results were obtained, provided the standard solutions were frequently checked.

Since the publication of Newcomer's method based on spectrophotometric data this method has also been carefully investigated, as well as a combination of Palmer's and Sahli's method with slight modifications described below.

History of Methods.

I. Acid Hematin Method.—Sahli (10), finding that methods employing artificial color standards were not satisfactory, brought forth the acid hematin method. Hemoglobin is converted into acid hematin by the addition of $0.1 \times \text{HCl}$ and then compared with a standard of like material. Numerous criticisms of the method have appeared and as many modifications been offered. Berzeller (2) claimed that the presence of lipoids alters readings. Stäubli (11) called attention to the time factor for maximum color development. Palmer (9) claimed that the standard is not permanent, that there is considerable delay in maximum color development, and that the method is not applicable for blood of different species. Haessler and Newcomer (4) offered a modification in the instrument used, using eleven standard tubes of different concentrations for comparison. Lilliendahl-Petersen (7) employed Sahli's principle in a Tallquist form. Newcomer (8) recently published a method of hemoglobin determination by comparing an acid hematin suspension of blood with a piece of brown-colored glass of definite thickness. The method is based on spectrophotometric data. The comparison is made with a Duboseq type of colorimeter.

II. Carbon Monoxide Method.—Hoppe-Seyler in 1892 (6) published his procedure of accurately determining hemoglobin in the form of carbon monoxide hemoglobin. The technical difficulties involved were too numerous for general adoption of the method.

Haldane (5) 8 years later revived Hoppe-Seyler's principle of hemoglobin determination but in a much simpler form. He used Gowers' instrument.

Palmer (9) in 1918 published a method which has found much favor. The principle is that of Hoppe-Seyler's procedure; *i.e.*, a color comparison of carbon monoxide hemoglobin solution with a standard of known hemoglobin content. Ammonia solution is used as a diluent instead of water. The color comparison is made in a Duboscq colorimeter.

EXPERIMENTAL.

I. Palmer Method.—We have used Palmer's method with only slight modifications. All experiments carried on during this investigation have been done on dogs. All blood is obtained by venous puncture. About 10 cc. of blood are drawn from the jugular vein with a glass syringe and emptied into a graduated centrifuge tube containing 2 cc. of a 1.6 per cent sodium oxalate solution. The plasma obtained by centrifugalization is carefully pipetted off, the tube slightly tilted, and a 1 cc. calibrated pipette of small lumen quickly inserted with the finger closing the opening at the upper end. Blood is slowly drawn up to the 1 cc. mark, the pipette is thoroughly wiped on the outside, and its contents are transferred into a small test-tube. The pipette is carefully rinsed in 2 cc. of N salt solution previously measured with this same pipette and emptied into a test-tube similar to the one containing the blood. This salt solution, now containing some red cells, is then carefully added to the 1 cc. of blood and the whole thoroughly mixed avoiding of course too vigorous shaking. Extreme care must be taken with this procedure so that the suspension of packed red blood cells is truly a dilution of one in three. The latter was ascertained to be the most convenient dilution, for the hemoglobin of our normal dogs is usually considerably over 100 per cent, frequently showing readings of 130 to 140 per cent. From the diluted blood cells suspension a 1 per cent solution of blood is made. 1 cc. of the diluted blood, 1:3, is drawn up into the same pipette used for diluting the packed cells as well as for measuring the original amount, is transferred to a 100 cc. volumetric flask containing

the 0.4 per cent ammonia solution, and made up to the 100 cc. mark with this same diluent. The solution is thoroughly mixed and at once saturated with carbon monoxide and read immediately. The percentage of hemoglobin obtained is multiplied by three—the packed red cells having been previously diluted 1:3—and this figure again multiplied by the red cell percentage of the blood computed from the hematocrit readings. In order to determine the accuracy of this apparently roundabout procedure, which is employed to prevent further bleeding for hemoglobin determination, readings were made from whole blood collected from the vein directly into a vessel containing sufficient dry sodium oxalate to prevent clotting and compared with the figures

TABLE I.*

Hemoglobin of packed red blood cells diluted 1:3.	Undiluted packed red cells.	Red cells from hematocrit.	Estimated hemoglobin from packed cells.	Hemoglobin of whole blood direct.	Difference.
<i>per cent</i>	<i>per cent</i>	<i>per cent</i>	<i>per cent</i>	<i>per cent</i>	
69	207	46.0	95	94	+1
57	171	48.0	82	83	-1
67	201	40.0	80	80	0
59	177	47.2	84	84	0
62.1	186.3	50.5	94	94	0
76.9	230.7	42.6	98	97	+1
63.0	189	38.4	73	73	0

* This work has been repeated and similar results have been obtained.

obtained by our means. Table I demonstrates the accuracy of the method as we employ it. It is obvious that by increasing the amount of hemoglobin used we tend to diminish any error of the method. 1 cc. of packed red cells should give more accurate readings than 20 mm. of whole blood.

Palmer's technique for the preparation of his standards has been closely adhered to. Palmer used either defibrinated ox or human blood. We have tried whole as well as defibrinated blood. Furthermore, blood obtained from different species has been investigated. In some cases blood has been obtained aseptically and the standard prepared from it with all aseptic precautions. With other standards only the usual cleanliness has been exercised.

The figures in Table II demonstrate the amount of fading of standards during the time of observation.

TABLE II.
Change in Color Value of Palmer Standards of Hemoglobin.

Standard No.	Source of blood.	Aug. 8, 1918.	Aug. 23, 1918.	Sept. 20, 1918.	Oct. 21, 1918.	Nov. 15, 1918.	Dec. 24, 1918.	Jan. 24, 1919.	Mar. 5, 1919.	April 1, 1919.	May 16, 1919.	June 23, 1919.	Aug. 5, 1919.	Sept. 7, 1919.	Oct. 21, 1919.	Total fading, per cent	Remarks.
I	Dog (whole).	100	99	90	75	73	74	74	74	71	75	76	75	75	82	29	Discarded. brownish tinge last 3 months.
II	Goat " sterile.	100	100	85	80	73	74	74	75	75	75	75	75	75	75	26	Discarded. brownish tinge last 3 months.
III	Dog (defibrinated).			100	99	89	87	86	86	80	80	81	82	82	82	20	No color change.
IV	Human "			100	93	100	93	89	89	84	84	84	85	85	84	16	" "
V	Sheep "			100	98	100	98	100	98	91	91	92	90	90	90	10	" "
VI	Dog (whole).			100	93	100	93	100	93	88	88	87	85	86	15	15	Spoiled.
VII	" (defibrinated).			100	100	100	100	100	100	100	100	100	100	100	0	0	No color change.
VIII	" "			100	99	100	99	100	99	99	99	99	99	96	5	5	" "

Discussion of Table II.

No. I showed the greatest fading, 29 per cent in 8 months, the maximum change taking place during the first 2 months. The slight color change did not interfere with color comparison.

No. II was prepared from goat blood with aseptic precautions and kept sterile throughout the experiment. Neither the fragility of red cells nor bacterial decomposition seems to play an important rôle in the fading of color. The change was nearly as much as with No. I, the maximum fading taking place during the first 3 months.

The curve of No. III is more promising, defibrinated blood showing slightly better keeping qualities than whole blood. The fading was not so rapid nor so much as in Standards I and II, nor was any color change apparent.

No. IV prepared from pooled defibrinated human blood showed about the same stability of color as defibrinated dog blood. The greatest change took place during the first 2 months; after that the fading was slight.

We were more successful in keeping No. V, prepared from defibrinated sheep blood, for the maximum fading was but 10 per cent as compared with 16 and 20 per cent when using defibrinated human and dog blood.

No. VI, having as its source whole dog blood, faded 15 per cent during 6 months, not so much as Standards I and II also prepared from whole blood, but still slightly more than when the blood was previously defibrinated.

Standard VII again prepared from defibrinated dog blood was the only one which remained unchanged during the period of observation, 7 months.

Standard VIII, for which defibrinated dog blood was again employed, showed a fading of 5 per cent during 5 months. While more promising than the earlier ones, still the change is too much for accurate hemoglobin determinations.

Another standard prepared from whole dog blood to determine again the difference obtained with whole and defibrinated blood is but 2 months old. The fading already amounts to 7 per cent during this period.

II. Acid Hematin Method.—Because of the uncertain stability of carbon monoxide hemoglobin solutions we have attempted to solve the problem by searching for a more stable color standard. In view of Sahli's work acid hematin was tried again. It offers an easier color comparison than do the reds of oxyhemoglobin and carbon monoxide hemoglobin. Sahli in his original work obtained satisfactory results, as did several of his coworkers. We have combined Palmer's method with Sahli's principle, that is, determined hemoglobin in the form of acid hematin, employing Palmer's method of standardization. The sealed tubes containing dilute acid hematin suspension as purchased (Sahli instrument) are unsatisfactory as was pointed out in the history of the methods. The thought that acid hematin in a more concentrated form might not fade so readily arose, and therefore 5, 10, and 20 per cent suspensions were investigated. Our method of procedure was as follows:

The oxygen capacity of a sample of dog's blood was determined by Van Slyke's method and the hemoglobin content computed therefrom. An acid hematin standard in the form of a 20 per cent suspension, so diluted that a 1 per cent dilution prepared from it would read 100 per cent, was made. Because of our experience with whole and defibrinated blood in the preparation of standards for the carbon monoxide method we employed defibrinated blood for our first standard. It is well known and has been mentioned in the history of acid hematin methods that the time factor for allowing the maximum color of acid hematin to develop plays a very important rôle. This standard, after preparation and dilution, was allowed to stand 24 hours to insure correct readings. A 1 per cent dilution prepared from the 20 per cent suspension was of course employed for direct color comparison. The same time factor was used for the blood to be tested. A 1 per cent suspension of blood is used for the determination of hemoglobin. 0.1 N HCl is employed throughout the procedure, for the original standard suspensions as well as for all further dilutions. The strength of HCl used within a certain limit is immaterial. We tried N, 0.1 N, and 0.5 N and obtained identical readings. Stronger solutions than N caused precipitation. The entire amount of diluent is used at once, that is, 1 cc. of diluted packed red cells is discharged

into the volumetric flask containing about 50 cc. of 0.1 N HCl, then mixed, and the volume made up to the 100 cc. mark with 0.1 N HCl. The suspension is then allowed to stand 24 hours in the ice chest, thoroughly shaken again, for it must be remem-

TABLE III.
Hemoglobin.

Palmer's method.	Author's modification.
<i>per cent</i>	<i>per cent</i>
75	74
70	70
77	76
77	77
74	73
73	73
74	74
75	74
76	75
73	73
64	64
63	63
76	76
45	45
60	60
84	85
69	69

TABLE IV.

Van Slyke's oxygen capacity method	Palmer's method.	Author's modification.
<i>per cent</i>	<i>per cent</i>	<i>per cent</i>
113	113	114
117	118	117
99	98	99
124	124	124
109	108	109

bered that we are dealing with a suspension and not a solution, and then read. The method of hemoglobin determination is exactly like that of Palmer's method and the readings obtained are almost identical as illustrated by the figures given in Tables III and IV.

The source of light used for color comparison makes little difference. Light from a northern exposure or that originating from a nitrogen-filled bulb filtered through "Daylite" glass gives equally good readings. The slight turbidity of the acid hematin suspension, and it is very slight in a 1 per cent dilution, does not in the least interfere with an accurate color comparison.

Different standards have been prepared, 5, 10, and 20 per cent suspensions, defibrinated as well as whole blood, also blood from different species. In fact, standards have been made up from the same sample of blood, one diluted for carbon monoxide hemoglobin determinations and the other in the form of acid hematin suspensions. The standards have been checked up once a month as those for Palmer's method. Material for the 1 per cent dilution has been withdrawn from the stock bottles once each week, and the container resealed with paraffin. On prolonged standing some of the hematin settles to the bottom of the container but when the mixture is thoroughly shaken again the readings obtained are unchanged. It is of course very essential that all acid hematin suspensions, whether dilute or concentrated, are thoroughly mixed before using.

The keeping qualities, or rather stability of color density, are best demonstrated by Tables V, VI, VII, and VIII.

Standard IVa (Table V) faded 4 per cent during a time interval of 11 months. The change was apparent during the 1st month. In the same period of time the carbon monoxide standard had faded 16 per cent.

These tables (V, VI, VII, and VIII) demonstrate the keeping qualities of our acid hematin mixtures. Up to the present time the last three have remained practically unchanged. We shall continue to check up these suspensions once each month in order to determine just how long they will remain stable.

A 1 per cent standard diluted from Standard VIIa at the time of preparation, April 1, 1919, and simply kept in an Erlenmeyer flask in the ice chest still read 100 per cent on October 21, 1919. Another 1 per cent suspension diluted from the defibrinated sheep blood standard and kept under the same conditions as the one mentioned above also remained unchanged during the period of observation, 4 months. For exactly how long a period the 1 per cent dilution would remain stable we do not at present

know. We consider it safe to make up our 1 per cent suspensions from the stock mixture once each month. It may be of some importance that all these standards were preserved in an

TABLE V.

Standard IVa; Acid Hematin. Defibrinated Human Blood Prepared Nov. 25, 1918.

Date.	New standard prepared.	Standard IVa.	Amount of fading.	Amount of fading of carbon monoxide standard.	Remarks.	
			<i>per cent</i>	<i>per cent</i>		
<i>1918</i>						
Dec. 24.....	100	97	3	7	Carbon monoxide standard was prepared from the same sample of blood.	
<i>1919</i>						
Jan. 24.....	100	97	3	11		
Mar. 5.....	100	96	4	11		
Apr. 1.....	100	97	3	16		
May 15.....	100	96	4	16		
June 23.....	100	97	3	16		
Aug. 6.....	100	96	4	15		
Sept. 7.....	100	96	4	15		
Oct. 21.....	100	96	4	16		

TABLE VI.

Standard Va; Acid Hematin. Defibrinated Sheep Blood Prepared Jan. 24, 1919.

Date.	New standard prepared.	Standard Va.	Amount of fading.	Amount of fading of carbon monoxide standard.	Remarks.
			<i>per cent</i>	<i>per cent</i>	
<i>1919</i>					
Mar. 5.....	100	100	0	2	Carbon monoxide standard was prepared from the same sample of blood.
Apr. 1.....	100	100	0	9	
May 15.....	100	100	0	9	
June 23.....	100	100	0	8	
Aug. 6.....	100	100	0	10	
Sept. 7.....	100	100	0	10	
Oct. 21.....	100	100	0	10	

ice chest with fairly constant temperature, fluctuations rarely exceeding 1-4°C.

TABLE VII.

Standard VIa; Acid Hematin. Whole Dog's Blood Prepared Mar. 5, 1919.

Date.	New standard prepared.	Standard VIa.	Amount of fading.	Amount of fading of carbon monoxide standard.	Remarks.
			<i>per cent</i>	<i>per cent</i>	
<i>1919</i>					
Apr. 1.....	100	100	0	7	Carbon monoxide standard prepared from the same sample of blood.
May 15.....	100	100	0	12	
June 23.....	100	99	1	13	
Aug. 6.....	100	100	0	15	
Sept. 7.....	100	100	0	14	
Oct. 21.....	100	100	0	Spoiled.	

TABLE VIII.

Standard VIIa; Acid Hematin. Defibrinated Dog's Blood Prepared Apr. 1, 1919.

Date.	New standard prepared.	Standard VIIa.	Amount of fading.	Amount of fading of carbon monoxide standard.	Remarks.
			<i>per cent</i>	<i>per cent</i>	
<i>1919</i>					
May 15.....	100	100	0	0	Carbon monoxide standard prepared from the same sample of blood.
June 23.....	100	100	0	0	
Aug. 6.....	100	100	0	0	
Sept. 7.....	100	100	0	0	
Oct. 21.....	100	100	0	0	

III. Newcomer Method.—While this investigation was being carried on Newcomer published his new method of estimation of hemoglobin, details of which have been described above. A piece of this brown semaphore glass 0.96 mm. in thickness was tested and gave most satisfactory readings when compared with Palmer's figures as shown in Table IX.

A Dubosq colorimeter is used in this laboratory and the brown glass inserted above the plunger. The corresponding cup is partially filled with distilled water for the reasons mentioned by Newcomer. As a source of light for these hemoglobin determinations either the lamp containing "Daylite" glass or light from a northern exposure gave equally satisfactory results. While the colors of the glass 0.96 mm. in thickness and the acid hematin suspension of the blood to be tested matched satisfac-

torily, the color is very light, almost a lemon-yellow when matched. It is therefore quite evident that this is somewhat of a disadvantage for darker shades are more easily matched and of course there is no means of regulating the depth of standard color as one does when using liquid mixtures. For example, with our liquid standards set at 10 the resulting readings of the test fluids range usually between 10 and 13, while with the colored glass, at least with the piece of this particular thickness, the readings are around 5 to 7 and are not so accurate as those around 10 or 12 with the Duboseq instrument.

TABLE IX.

Palmer's method.	Newcomer's method (glass 0.96 mm. thick).	Difference.
<i>per cent</i>	<i>per cent</i>	
113	114	+1
116	114	-2
99	100	+1
107	108	+1
98	101	+3
117	118	+1
100	100	0
100	100	0
100	101	+1
100	103	+3
100	99.2	-0.8
Average difference		+0.73

The added advantage of course is that all artificial standards like this glass are supposedly permanent in color and this obviates the necessity of liquid standard preparations. Because of the pale color of the standard glass we purchased another piece somewhat thicker—1.02 mm.—hoping to obtain easier readings. While the color was slightly darker in this new piece our readings were not so accurate as is evident from the figures cited (Table X).

The difference in readings (Table X) was more than with the piece 0.96 mm. in thickness, an average of 0.73 higher with the former glass as compared to 2.4 points lower with the thicker one. We feel certain that this larger difference is due to the

fact that with the piece 1.02 mm. thick the color, although darker, is not so readily matched. The suspension of acid hematin demonstrates of course a very slight turbidity, the lack of which is very noticeable when using the heavier glass. The color of the latter is a clear yellowish brown while the acid hematin because of its slight opaqueness seems a somewhat different shade of brown. Some of the readings cited were made by different workers in the laboratory and the same difficulty was voiced by all that the colors do not seem to be quite the same. Two pieces of glass placed one on top of the other, each 1.02 mm. in thickness, increased the difference in readings considerably, as

TABLE X.

Palmer's method.	Newcomer's method (glass 1.02 mm. thick).	Difference.
<i>per cent</i>	<i>per cent</i>	
64	62	-2
63	60	-3
76	72	-4
45	47	+2
60	56	-4
84	81	-3
69	66	-3
Average difference		-2.4

well as the difficulty of exact color match. Newcomer (8) states that it is impossible to secure an artificial color match which runs true through a range of thicknesses. While the actual difference in thickness of the pieces of glass purchased—using of course only one at a time—seems slight, a decided difference in color match is apparent.

In view of the above mentioned difficulties we prefer using the liquid acid hematin standards.

DISCUSSION.

In summarizing our observations with the Palmer method it is evident that as long as the standard solutions are prepared once a month very accurate results may be obtained. The method itself is certainly simple and easily carried out by even

comparatively inexperienced laboratory workers. The main disadvantage lies in the color fading of the standard solutions. Among nine different standards observed for a period of from 2 to 13 months we have found but one solution which for nearly 7 months remained unchanged. The remaining eight all faded sufficiently to prohibit their use for accurate work, with one exception possibly—Standard VIII—which demonstrated a fading of only 5 per cent during a 5 months period. Considering the figures presented it seems that better results were obtainable with blood previously defibrinated than with whole blood. For a time interval of 3 months the standard solutions prepared from defibrinated blood demonstrated a fading of from 0 to 13 per cent as compared with 13 to 27 per cent evident in those mixtures originating from whole blood. We have never encountered any difficulty with reference to a true change of color, at least during a period of 6 months. During the last few months of observation a very slight brownish tinge was noticeable but never sufficient to interfere seriously with a color comparison, excepting perhaps Nos. I and VI, which were discarded after 8 months observation. The greatest change in color density in standards prepared from whole blood apparently takes place during the first 2 months and reaches its maximum during the 3rd month. From then on the change is but comparatively little and remains so, in some instances for a year or over. With the defibrinated blood, I think we have a standard of better keeping qualities; the change is not quite so pronounced. Although two of the defibrinated blood mixtures, Nos. III and IV, showed a fading of 11 per cent each during a time interval of 2 months, we have three others where the change was considerably less, one solution demonstrating but a 5 per cent loss of color within 5 months, another remaining unchanged for nearly 7 months, and a third fading 10 per cent in 9 months.

The type of hemoglobin evidently plays no important rôle, dog's blood apparently giving as satisfactory results as goat's, sheep's, or human blood; or rather the other species mentioned offer no more stable hemoglobin solutions than dog's blood.

Bacterial decomposition does not seem to be a very important factor, for blood obtained aseptically and the hemoglobin solution prepared with sterile precautions demonstrated no more

stable qualities than did those standards prepared with only the usual care and cleanliness.

It should be mentioned here that all these stated observations pertain to the stock solutions, the 20 per cent dilutions. We have never attempted to keep the 1 per cent dilutions prepared from the concentrated mixtures for more than a week, at least under experimental conditions existing here. A 1 per cent solution prepared will not fade within a week if kept on ice and resaturated with carbon monoxide each time the container is opened. After that time interval a change does take place which although not apparent to the eye is readily demonstrable when checked against the oxygen capacity method. Appleton (1) states that the 1 per cent solutions prepared by her began to deteriorate in from 2 to 4 weeks. During her investigation the diluted solution was kept saturated by a continual flow of gas. Why such a difference in stability occurs we do not know. Frequent opening of containers and resaturation with CO seem to give no better results than resaturation once a month. While a standard is being used for routine work it is necessary to open the container once each week in order to procure the necessary material for one 1 per cent dilution.

From the tables of acid hematin standards, it is readily seen that, while these acid hematin mixtures may change in time, they certainly have proved themselves to be much more stable than the carbon monoxide solutions. One may with perfect safety and with complete assurance of obtaining accurate results employ these acid hematin suspensions for 6 months at least. The stock mixtures above mentioned will of course be observed to determine just how long they actually remain unchanged.

The method of preparing blood for hemoglobin determinations in the form of acid hematin is slightly simpler than the carbon monoxide method, for the former makes unnecessary the extra step of saturation with carbon monoxide. The slight disadvantage is the time interval necessary for the maximum color of acid hematin to develop. In using large quantities of blood (at least much greater amounts than are used clinically) we have allowed 24 hours. This, however, is not necessary as a 1 hour interval gives accurate reading. We have observed no difference between figures obtained after 60 minutes standing and 24 hours.

The latter time happened to be more convenient in our experimental work. Newcomer published a table with his method showing the exact percentages of color development of acid hematin in given periods of time. He considers 40 minutes as safe.

Palmer in his publication states that blood of different species cannot be used for hemoglobin determinations in the form of acid hematin. As will be seen from our tables, we have standards prepared from human, dog's, and sheep's blood and have compared human blood with both dog's and sheep's blood standards without encountering any difficulty whatsoever. The comparisons have been made in all combinations possible with our material and readings have checked accurately. The figures presented in the tables readily answer the question of stability. While the latter may not be permanent or remain unchanged indefinitely, still it is much less time-consuming to prepare a fresh standard once every 6 months instead of once each month as we have had to do when employing the carbon monoxide method.

The Newcomer method would of course be the best solution of the entire problem, but as mentioned before the color match is not exact. The use of as simple a standard as a piece of colored glass certainly is a great advantage. The difference in color may not be so apparent to all eyes. The table accompanying the glass standard is an asset, as it definitely settles the question of time interval for development of the maximum color of acid hematin, and thus does away with one of the disadvantages of the earlier acid hematin methods.

Since the completion of this work a communication of Cohen and Smith (3) has appeared which confirms much of this work. They suggest the same standard solution because of its stability under army camp conditions.

CONCLUSIONS.

1. The Sahli hemoglobin method when using the color tubes accompanying the instrument gives very inaccurate results because of the decided variance in color density of the standard tubes, due to fading.

2. The Palmer method offers very satisfactory means of hemoglobin determinations if the standard solutions are freshly prepared. The method itself is very simple and may be successfully carried out by anyone familiar with colorimetry. The standard solutions prepared in the laboratory although carefully made have not been sufficiently stable to insure accurate determinations over periods of more than 3 to 4 weeks.

3. Newcomer's method obviates many difficulties heretofore observed with other procedures and gives good results with the glass 0.96 mm. in thickness, although the color is quite pale. When using the heavier glass, 1.02 mm. in thickness, the color match is only approximate and the figures obtained are not so satisfactory as those resulting from use of the thinner piece.

4. A method is presented applying Palmer's procedure to Sahli's principle which has proved most satisfactory. It removes the difficulty we encountered with Palmer's method, the lack of stability of color in the standard solutions. It has the advantage of an easier color match than that of red tint. The standards prepared have remained sufficiently unchanged for a period of 11 months to insure accurate hemoglobin determinations during this long period.

It may be suggested that for routine hospital work an acid hematin standard prepared in this way and kept at relatively constant temperature will remain unchanged for 8 months or longer. 1 per cent solutions may be prepared from time to time from the standard concentrated solution and this 1 per cent solution can be used to fill the standard tube of the common Sahli hemoglobinometer. This insures an accurate base line for hemoglobin determinations and with refilling of the Sahli tubes once a month will give accurate clinical determinations. Such clinical determinations are not the rule and are much to be desired.

BIBLIOGRAPHY.

1. Appleton, V. B., *J. Biol. Chem.*, 1918, xxxiv, 369.
2. Berzeller, L., *Biochem. Z.* 1918, lxxxvii, 23.
3. Cohen, B., and Smith, A. H., *J. Biol. Chem.*, 1919, xxxix, 489.
4. Haessler, H., and Newcomer, H. S., *Arch. Int. Med.*, 1916, xvii, 806.
5. Haldane, J., *J. Physiol.*, 1899-1900, xxv, 295; 1900-1901, xxvi, 497.
Haldane, J., and Smith, J. L., *J. Physiol.*, 1899-1900, xxv, 331.

6. Hoppe-Seyler, F., *Z. physiol. Chem.*, 1891-92, xvi, 505.
Hoppe-Seyler, G., *Z. physiol. Chem.*, 1895-96, xxi, 461.
7. Lilliendahl-Petersen, N., *Berl. klin. Woch.*, 1914, li, 551.
8. Newcomer, H. S., *J. Biol. Chem.*, 1919, xxxvii, 465.
9. Palmer, W. W., *J. Biol. Chem.*, 1918, xxxiii, 119.
10. Sahli, H., *Lehrbuch der klinischen untersuchungs-methoden*, **Leipzig**,
4th edition, 1905, 655-664; 5th edition, 1909, 845; *Verhandl. Kong.
innere Med.* 1902, xx, 230; *Jahresb. Fortsch. Thierchem.*, 1903, xxxii,
232.
11. Stäubli, C., *Münch. med. Woch.*, 1911, lviii, 2429.
12. Van Slyke, D. D., *J. Biol. Chem.*, 1918, xxxiii, 127.
13. Whipple, G. H., and Hooper, C. W., *Am. J. Physiol.*, 1917-18, xlv,
573, 577.

DIGESTIBILITY OF CERTAIN MISCELLANEOUS VEGETABLE FATS.*

BY ARTHUR D. HOLMES AND HARRY J. DEUEL, JR.

*(From the Office of Home Economics, U. S. Department of Agriculture,
Washington.)*

(Received for publication, November 29, 1919.)

INTRODUCTION.

The shortage of food fats which existed during the war will, in all probability, be more or less permanent. For this reason it seemed desirable to obtain information on the nutritive value of some oils which have either not been used as foods or only used as such to a limited extent, but which might perhaps be thus used in case of need.

This office has made similar studies of the digestibility of about 50 more or less common fats and oils (1). The results seem to indicate that the digestibility coefficient of the fats having melting points above body temperature (37°) varies inversely with the melting point (2). It has also been found that most of the common oils are from 93 to 98 per cent utilized by the human body. Nevertheless, some oils were found to cause digestive disturbances and some oils are less tolerated by the body than others. Therefore, before we can say whether or not an oil or fat is suitable for use in the human dietary, we must know not only its coefficient of digestibility but also its effect on the human body when eaten in quantities at least equal to those in which butter or other common fat is used in the average dietary.

This paper records the digestibility of avocado and cupuassú bean fats, and cohune, hempseed, palm-kernel, and poppy-seed oils. Avocado fat is eaten largely in parts of the tropics, and

* Prepared under the direction of Dr. C. F. Langworthy, Chief, Office of Home Economics. Published with permission of the Secretary of Agriculture.

to some extent in this country as it occurs in the fruit; but the other oils studied have been used for food purposes only in a limited way, if at all, in this country. The study of the nutritive value of these oils seemed valuable not only on account of its interest in the field of nutrition but also on account of its very practical bearing upon our food supply, especially in times of shortage of the more common fats.

EXPERIMENTAL.

General Procedure.

The methods followed in the tests here reported are essentially the same as those followed in the previous digestion experiments conducted by this office. The fats, with the exception of avocado fat, were incorporated in a special corn-starch blanc-mange or pudding, and this was eaten with a basal ration consisting of a commercial wheat biscuit, oranges, and sugar, which supplied only a very small amount of fat in the total ration in comparison to that eaten in the blanc-mange. The avocado fat was eaten as it occurs in the fresh fruit pulp with a basal ration of milk and crackers, which supplied considerably less than one-half as much fat as was furnished by the avocados. Tea or coffee without cream was used if desired.

The amount of food eaten was accurately weighed and the weight of the water-dried feces for the experimental period was recorded. The methods for the separation of feces, analyses, etc. were the same as those reported in earlier papers (1).

The subjects who assisted in these tests were men, apparently in normal health, ranging in age from 20 to 40 years, who were students in local universities. They were familiar with this type of work and thoroughly trustworthy.

I. Avocado Fat.—The avocado (*Persea gratissima*) is a fruit indigenous to tropical and subtropical regions in the western hemisphere. In the United States it is cultivated to an increasing extent in Florida and California. The avocado, because of the large amount of fat it contains and because of its pleasant taste, seemed of interest to study. The avocados which we used in our experiments contained about 15 per cent fat, although Condit and Jaffa (3) state the average fat content to be about 20 per

cent. It is supposed to be present in the form of an emulsion, which probably accounts for the difficulty in expressing it from the pulp (Table I). Mattil (4), in two tests made during the progress of our experiments, using a basal ration of Graham crackers, cottage cheese, and milk, reports the digestibility of the total fat in a diet in which avocado fat was the predominating fat constituent as 93.7 per cent and 89.1 per cent. If the same correction which we made in our experiments for the fat of the diet of accessory foods is applied, the average of Mattil's figures becomes practically identical with the 88 per cent which we report for the digestibility of avocado fat alone. There were no

TABLE I.

Summary of Digestion Experiments with Avocado Fat in a Simple Mixed Diet.

Experiment No.	Subject.	Digestibility of entire ration.				Estimated digestibility of avocado fat alone.
		Protein.	Fat.	Carbo- hydrate.	Ash.	
		<i>per cent</i>	<i>per cent</i>	<i>per cent</i>	<i>per cent</i>	<i>per cent</i>
527	H. R. G.	85.0	90.8	96.1	74.9	88.3
529	P. K.	88.0	90.4	97.4	76.0	88.5
530	C. J. W.	84.5	88.7	97.6	73.7	86.8
Average		85.8	90.0	97.0	74.9	87.9

physiological disturbances caused by the ingestion of the avocado fat. The maximum intake by one subject was 124 gm. of avocado fat per day, while the average intake per man per day was 100 gm.

II. Cohune Oil.—Cohune oil is obtained from the kernel of the cohune palm (*Attalea cohune*), which grows quite extensively in Central America. The oil resembles coconut oil both in taste and odor, but has not been used very largely, due to the great difficulty experienced in breaking the very hard outer shell of the nut. At room temperature, the oil¹ has only a trace of solid fat. The subjects ate on an average of 52 gm. of cohune oil per man per day, while one subject ate 64 gm. per day for the experimental period (Table II). The oil was very well assimilated, being on an average 99 per cent digested, and produced no abnormal physiological effects.

¹ The sample used in this experiment was obtained through the courtesy of H. S. Bailey of the Bureau of Chemistry.

230 Digestibility of Certain Vegetable Fats

III. Cupuassú Fat.—The cupuassú fat is obtained by pressing the seeds which occur in the pulp of the fruit of the cupuassú tree (*Theobroma grandiflora* Schum), which is one of the most important fruit trees of Pará Brazil. Cupuassú fat has not been used for food purposes in this country. Nevertheless it seemed

TABLE II.

Summary of Digestion Experiments with Cohune Oil in a Simple Mixed Diet.

Experiment No.	Subject.	Digestibility of entire ration.				Estimated digestibility of cohune oil alone.
		Protein.	Fat.	Carbo-hydrate.	Ash.	
		<i>per cent</i>	<i>per cent</i>	<i>per cent</i>	<i>per cent</i>	<i>per cent</i>
621	A. A. F.	64.0	94.7	96.2	66.2	99.5
622	P. K.	68.8	94.9	97.0	80.0	98.6
623	J. C. M.	53.8	94.0	94.5	69.5	99.3
624	C. J. W.	67.3	94.6	95.6	77.5	98.8
Average		63.5	94.6	95.8	73.3	99.1

TABLE III.

Summary of Digestion Experiments with Cupuassú Fat in a Simple Mixed Diet.

Experiment No.	Subject.	Digestibility of entire ration.				Estimated digestibility of cupuassú fat alone.
		Protein.	Fat.	Carbo-hydrate.	Ash.	
		<i>per cent</i>	<i>per cent</i>	<i>per cent</i>	<i>per cent</i>	<i>per cent</i>
637	A. A. F.	78.4	91.0	97.4	63.3	95.3
638	P. K.	69.1	88.4	96.5	48.8	94.1
639	J. C. M.	77.5	89.6	96.1	54.2	95.0
640	C. J. W.	75.7	86.3	96.2	57.0	92.1
Average		75.2	88.8	96.6	55.8	94.1

to be a fat worth attention, since on account of the abundance of the cupuassú trees in Brazil it would be available in fairly large quantities.

It is a light yellow fat, solid at ordinary temperatures, and possessing the odor of cacao butter (Table III). The average digestibility, 94.1 per cent, found for cupuassú fat agrees very closely with that of cocoa butter, 94.7 per cent found in previous investigations (5). Only 41 gm. of cupuassú fat were consumed

on an average per man per day. The cupuassú fat caused slight physiological disturbances, such as nausea and looseness of the bowels, similar to those noted in the experiments with cocoa butter.

IV. Hempseed Oil.—Hempseed oil is expressed from the seeds of the hemp plant (*Cannabis sativa*). It is a yellowish green oil which has had practically no use as a food in this country, but has been almost wholly used for industrial purposes. It was eaten without aversion and caused no physiological disturbances. In our experiments hempseed oil was very completely assimilated, being on an average 98.5 per cent digested (Table IV). The subjects ate on an average 54 gm. per man per day, while one subject ate 57 gm. per day without any ill effects.

TABLE IV.

Summary of Digestion Experiments with Hempseed Oil in a Simple Mixed Diet.

Experiment No.	Subject.	Digestibility of entire ration.				Estimated digestibility of hempseed oil alone.
		Protein.	Fat.	Carbo- hydrate.	Ash.	
		<i>per cent</i>	<i>per cent</i>	<i>per cent</i>	<i>per cent</i>	<i>per cent</i>
906	J. F. C.	79.1	94.4	97.4	75.8	98.1
909	G. S. M.	56.4	94.7	96.3	65.0	99.5
910	W. O'C.	65.8	94.0	97.2	63.9	97.9
Average		67.1	94.4	97.0	68.2	98.5

V. Palm-Kernel Oil.—Palm-kernel oil is one of the two oils obtained from the fruit of an African palm tree (*Elaeis guineensis*). It is obtained by pressing the interior portion of the kernels. Palm oil, obtained from the exterior of the fruit, is rarely used for food purposes outside of the countries in which it is produced, but finds commercial application in the United States in the tin plate industry. The palm-kernel oil used in this experiment was obtained by cracking the kernels by hand and expressing the oil from the meats by a small sized, continuous process oil expeller. The oil possessed a pleasant odor and flavor much resembling coconut oil, but had a somewhat higher melting point, being a white solid at ordinary temperatures. The subjects ate on an average 100 gm. of palm-kernel oil per man per day

232 Digestibility of Certain Vegetable Fats

(Table V). The maximum intake was 121 gm. per day for the experimental period. The palm-kernel oil was very well assimilated, being 98 per cent utilized by the body, and it caused no physiological disturbances.

TABLE V.

Summary of Digestion Experiments with Palm-Kernel Oil in a Simple Mixed Diet.

Experiment No.	Subject.	Digestibility of entire ration.				Estimated digestibility of palm-kernel oil alone.
		Protein.	Fat.	Carbo- hydrate.	Ash.	
		<i>per cent</i>	<i>per cent</i>	<i>per cent</i>	<i>per cent</i>	<i>per cent</i>
685	A. A. F.	56.3	94.2	96.1	32.6	97.7
686	P. K.	81.0	93.9	99.2	82.7	95.1
687	J. C. M.	67.2	97.5	96.5	64.8	99.9
688	A. A. R.	39.3	95.7	95.6	45.7	99.3
Average		61.0	95.3	96.9	56.5	98.0

TABLE VI.

Summary of Digestion Experiments with Poppy-Seed Oil in a Simple Mixed Diet.

Experiment No.	Subject.	Digestibility of entire ration.				Estimated digestibility of poppy-seed oil alone.
		Protein.	Fat.	Carbo- hydrate.	Ash.	
		<i>per cent</i>	<i>per cent</i>	<i>per cent</i>	<i>per cent</i>	<i>per cent</i>
956	J. F. C.	62.4	92.8	96.1	57.3	96.1
957	F. K.	47.3	91.4	96.6	58.7	96.9
958	G. S. M.	67.0	93.4	96.7	56.7	98.5
959	W. O'C.	38.7	89.6	97.2	41.3	94.8
981	E. L. M.	58.0	89.2	96.4	47.7	95.1
982	G. S. M.	58.7	95.5	96.0	57.2	100.0
983	W. O'C.	11.5	87.4	96.5	32.7	92.9
Average		49.1	91.3	96.5	50.2	96.3

VI. Poppy-Seed Oil.—Poppy-seed oil is obtained by pressing the oil from the seeds of *Papaver album* and *Papaver nigrum*, two varieties of poppy, which are largely grown in the Orient. The best qualities of oil are used largely for edible purposes in Europe, but to a much smaller extent here. The best grades are used also for

artists' paints and other special technical purposes, while poorer qualities are used for soap-making. The oil used in these experiments was a good grade commercial oil which had a light yellow color and was without pronounced odor or flavor. It had the

TABLE VII.

Average Amount of Blanc-Mange and Total Food per Man per Day.

Diet.	Weight.	Water.	Protein.	Fat.	Carbohydrate.	Ash.	Fuel value.
	gm.	gm.	gm.	gm.	gm.	gm.	cal.
Avocado fat:							
Fat-rich avocado pulp . . .	688.4	547.8	6.0	99.8	30.0	4.7	1,042
Total food	1,603.4	1,194.9	43.0	153.9	198.2	13.5	2,350
Cohune oil:							
Fat-rich blanc-mange . . .	650.2	342.9	14.2	52.3	234.4	6.4	1,465
Total food	1,131.8	628.9	28.2	54.6	410.4	9.7	2,246
Cupuassú fat:							
Fat-rich blanc-mange . . .	536.0	310.9	22.5	39.9	159.5	3.2	1,087
Total food	902.6	496.5	36.3	42.0	321.6	6.1	1,810
Hempseed oil:							
Fat-rich blanc-mange . . .	406.8	177.2	7.3	53.5	165.7	3.1	1,174
Total food	1,026.2	538.5	21.2	55.8	403.9	6.7	2,205
Palm-kernel oil:							
Fat-rich blanc-mange . . .	577.7	251.9	9.8	100.3	213.0	2.7	1,785
Total food	1,001.2	490.7	22.9	102.4	379.5	5.6	2,531
Poppy-seed oil:							
Fat-rich blanc-mange	356.8	154.9	6.4	49.0	144.5	2.3	1,045
Total food	916.3	521.6	17.8	50.9	320.4	5.6	1,810

following constants: Iodine number 135.50, refractive index at 40°C. 63, and 1.24 per cent of free fatty acid. The subjects ate on an average 50 gm. of poppy-seed oil and one subject ate 60 gm. daily for the experimental period. The oil caused no physiological disturbances and was well assimilated by the body, being 96.3 per cent digested (Table VI).

234 Digestibility of Certain Vegetable Fats

Table VII reports the average amount of the fat-rich blanc-mange eaten per man per day and also the average total food consumed. Table VIII reports the coefficients of digestibility obtained by averaging the results of each group of experiments.

TABLE VIII.

Average Digestibility of Diet and Estimated Digestibility of Fats Studied.

Kind of fat.	No. of experiments.	Digestibility of entire ration.				Estimated digestibility of fats studied.
		Protein.	Fat.	Carbohy- drates.	Ash.	
		<i>per cent</i>	<i>per cent</i>	<i>per cent</i>	<i>per cent</i>	
Avocado fat	3	85.8	90.0	97.0	74.9	87.9
Cohune oil	4	63.5	94.6	95.8	73.3	99.1
Cupuassú fat	4	75.2	88.8	96.6	55.8	94.1
Hempseed oil	3	67.1	94.4	97.0	68.2	98.5
Palm-kernel oil	4	61.0	95.3	96.9	56.5	98.0
Poppy-seed oil	7	49.1	91.3	96.5	50.2	96.3

SUMMARY.

1. The digestibility of several fats and oils has been studied. The digestibility coefficients obtained were: Avocado fat, 87.9 per cent; cohune oil, 99.1 per cent; cupuassú fat, 94.1 per cent; hempseed oil, 98.5 per cent; palm-kernel oil, 98.0 per cent; and poppy-seed oil, 96.3 per cent.

2. The digestibility of the protein and carbohydrate of the entire ration was essentially the same as that in other experiments of a similar nature, indicating that the fats exercised no unusual effect on the utilization of these constituents.

3. These fats and oils, with the possible exception of cupuassú fat, which caused slight disturbances, produced no abnormal physiological effects and may be regarded as satisfactory for food purposes. Cohune, hempseed, palm-kernel, and poppy-seed oils especially are very highly utilized by the human body.

BIBLIOGRAPHY.

1. Langworthy, C. F., and Holmes, A. D., *U. S. Agric. Dept., Bull. 310*, 1915; *Bull. 505*, 1917; *Bull. 507*, 1917. Holmes, A. D., *U. S. Agric. Dept., Bull. 613*, 1919; *Bull. 630*, 1918; *Bull. 687*, 1918; *Bull. 781*, 1919.
2. Langworthy, C. F., and Holmes, A. D., *U. S. Agric. Dept., Bull. 310*, 1915, 21.
3. Condit, I. J., and Jaffa, M. E., *California College of Agric. Exp. Station, Bull. 254*, 1915, 381.
4. Mattil, *Ann. Ref. California, Avocado Assn.*, 1916, 93.
5. Langworthy, C. F., and Holmes, A. D., *U. S. Agric. Dept., Bull. 505*, 1917, 17, 18.



A METHOD FOR THE DETERMINATION OF METHEMOGLOBIN IN BLOOD.

BY WILLIAM C. STADIE.

(From the Hospital of The Rockefeller Institute for Medical Research.)

(Received for publication, December 29, 1919.)

In the course of experimental work on the production of methemoglobin in pneumococcal infections it became desirable to have some simple method for the determination of methemoglobin in blood. The author was unable to find in the literature any method other than the complex and time-consuming spectrophotometric method, which requires an elaborate apparatus and is not very suitable when many determinations have to be made. The method outlined below is simple, quickly performed, and has given satisfactory results in a study of methemoglobin formation which will be published shortly.

Principle of the Method.—The method depends upon the fact that both hemoglobin and methemoglobin are changed quantitatively to cyanhemoglobin by dilute solutions of potassium cyanide. The color of the latter is a brilliant orange-red and is very suitable for colorimetric comparison. The change of methemoglobin to cyanhemoglobin is rapid, even in the cold. Hemoglobin, however, changes slowly at room temperature, and must be heated to 50°C. for about $\frac{1}{2}$ hour for complete conversion. That the cyanhemoglobin from hemoglobin is identical with that from methemoglobin is shown by the identical absorption spectra in the two cases.

In practice the difficulty arising from the slow conversion of hemoglobin into cyanhemoglobin is avoided by converting all the hemoglobin present into methemoglobin by the use of a little potassium ferricyanide, and then converting the methemoglobin into cyanhemoglobin. The resulting solution of cyanhemoglobin is compared with a standard of known strength in a Duboscq colorimeter.

The total amount of hemoglobin plus methemoglobin having been thus determined colorimetrically, the hemoglobin content of the blood containing the two pigments (hemoglobin and methemoglobin) is determined separately from the oxygen capacity, employing the technique outlined in Van Slyke's¹ gasometric determination of hemoglobin. The hemoglobin determined by the oxygen capacity is subtracted from the hemoglobin plus methemoglobin determined together as cyanhemoglobin; the difference is the methemoglobin.

Details of the Method.—Oxalated whole blood is used. 2.00 cc. of the blood are placed in a 100 cc. flask and 50 cc. of water are added which effect hemolysis in a few seconds. 0.5 cc. of a 0.1 M (3.0 per cent) solution of potassium ferricyanide is added, and the

TABLE I.

Factors for Calculating Results from Analysis of 2 Cc. of Blood Saturated with Air.

Temperature.	Air physically dissolved by 2 cc. of blood. Subtract from gas volume to obtain corrected gas volume representing O ₂ set free from hemoglobin.	Factor by which corrected gas volume is multiplied in order to give hemoglobin in 100 cc. of blood.
°C.	cc.	gm.
15	0.037	$34.7 \times \frac{B}{760}$
16	0.036	34.6
17	0.036	34.3
18	0.035	34.2
19	0.035	34.0
20	0.034	33.9
21	0.033	33.7
22	0.033	33.5
23	0.032	33.4
24	0.032	33.1
25	0.031	33.0
26	0.030	32.9
27	0.030	32.6
28	0.029	32.5
29	0.029	32.3
30	0.028	32.1

¹ Van Slyke, D. D., *J. Biol. Chem.*, 1918, xxxiii, 127.

flask allowed to stand for 15 to 20 minutes. (It was found that these conditions are optimum for the complete conversion of the hemoglobin to methemoglobin, only the faintest visible hemoglobin band being present at the end of 20 minutes with this amount of potassium ferricyanide.) 5 cc. of a 0.1 per cent potassium cyanide solution are now added. The change to cyanhemoglobin is immediate. Water is added to the mark and the solution compared with a standard of known strength in a colorimeter. The result is the hemoglobin plus methemoglobin, which we express as gm. of "total hemoglobin" per 100 cc. of blood.

A small portion (4 to 5 cc.) of the blood or hemoglobin solution is aerated in a funnel and its total oxygen capacity determined by the Van Slyke method. Barcroft² has shown that under these conditions (180 mm. of oxygen tension, 0 mm. of carbon dioxide tension, and room temperature) the hemoglobin is practically 100 per cent saturated. Therefore the oxygen capacity corresponds to the amount of hemoglobin present, and by dividing by 1.34 (the volume of oxygen combined with 1 gm. of hemoglobin) we obtain the gm. of hemoglobin per 100 cc. of blood. For convenience of calculation the factors for the conversion of cc. of gas combined with 2 cc. of blood into gm. of hemoglobin per 100 cc. of blood are given in Table I (modified from Van Slyke¹).

Preparation of Standard.—The standard is prepared from fresh whole oxalated or defibrinated blood which is known to contain no methemoglobin. The hemoglobin content (gm. per 100 cc.) is determined gasometrically. 500 cc. of standard are made by placing 10 cc. of the blood in a 500 cc. flask, hemolyzing with about 300 cc. of water, and adding 2.5 cc. of the potassium ferricyanide solution. After 20 minutes, 25 cc. of the potassium cyanide solution are added and the mixture is diluted to the mark. The blood pigment value of this solution is known from the gasometric determinations and the unknown may be compared directly with it or suitable dilutions of the standard may be made.

² Barcroft, J., *The respiratory function of the blood*, Cambridge, 1914.

Calculation of Results.—An example will make this clear.

Strength of standard 15.0 gm. of hemoglobin per 100 cc. of blood.
 Comparison of cyanhemoglobin in colorimeter; Standard 10, Unknown 12.
 Unknown has $\frac{1}{2}$ of 15.0 or 12.5 gm. of total blood pigment per 100 cc.
 Gasometric determination of hemoglobin 10.0 gm. per 100 cc.
 Therefore, sample has 12.5—10.0 or 2.5 gm. of methemoglobin per 100 cc.

DISCUSSION.

The deep orange-red color of the cyanhemoglobin is adapted to accurate color comparisons. Fiftyfold dilution of normal blood, containing approximately 15 gm. of hemoglobin per 100 cc., gives about the optimum depth of color. A 1:100 dilution gives too light a color and requires that the standard be set at 20.

TABLE II.

Hemoglobin + methemoglobin observed per 100 cc. (Colorimetric.)	Hemoglobin calculated per 100 cc. (Gasometric).	Methemoglobin observed per 100 cc.	Methemoglobin calculated per 100 cc.
gm.	gm.	gm.	gm.
6.89	6.74	0.15	0.00
6.89	6.43	0.31	0.46
6.86	6.15	0.69	0.71
6.62	4.56	2.17	2.06
6.58	0.20	6.54	6.38

The author has attempted to determine methemoglobin colorimetrically in blood by converting it, with the hemoglobin, into carbon monoxide hemoglobin, for estimation by the Palmer³ method, and into acid hematin for estimation by the Sahli principle; but both attempts were unsuccessful, since methemoglobin does not form products with carbon monoxide or acid which can be colorimetrically compared with the products formed from hemoglobin.

Results.—A solution of hemoglobin obtained from sheep's cells previously washed with saline was used. A gasometric determination of this solution showed it to contain 6.74 gm. of hemoglobin per 100 cc. Part of this solution was shaken for $\frac{1}{2}$ hour with an amount of potassium ferrieyanide calculated to change all of it

³ Palmer, W. W., *J. Biol. Chem.*, 1918, xxxiii, 119.

to methemoglobin. The hemoglobin content of this solution (gasometric) was 0.20 gm. per 100 cc. These two solutions were mixed in various proportions so as to make solutions containing varying but known amounts of hemoglobin and methemoglobin. The methemoglobin content was then determined as outlined above, using a standard from ox blood which had been prepared a few days before. The results are shown in Table II.

CONCLUSIONS.

A colorimetric method for the determination of blood pigments is given which is simple and rapid, and which, combined with a simultaneous determination of the hemoglobin by the gasometric method of Van Slyke, gives the methemoglobin content of the blood.



A STUDY OF THE NEPHELOMETRIC VALUES OF CHOLESTEROL AND THE HIGHER FATTY ACIDS. II.

By F. A. CSONKA.

(From the Laboratory of Dr. James P. McKelvy, Pittsburgh.)

(Received for publication, December 8, 1919.)

Among the many influencing factors which govern the nephelometric value (N. V.) of fatty acids and cholesterol, I wish to discuss, in the present paper, certain important ones in their relation to saponification, because practically all quantitative fat determinations necessitate such a procedure. These factors consist of, on the one hand, substances which are essential to the determination, such as the reagents, or those which facilitate the production of colloidal suspensions, designated as protective colloids; and, on the other hand, conditions like heat, concentration, and the sequence of mixing the reagents in the development of turbidity.

However, before we apply either a procedure like saponification, or employ a protective colloid, we must ascertain its influence on the nephelometric values of the substances in question; an increase in the value is always to be desired, but a decrease is liable to render the determination less delicate, and therefore unsatisfactory as a micro method. Studies of this type are of interest not only as a preliminary step to the development of a new method, but also as a means of discovering the defects or proving the accuracy of a method already in use.

In the first paper,¹ where the suggested term nephelometric value was defined, the importance of acid concentration upon the nephelometric values of the fatty ingredients was emphasized and it was shown that fatty acids, as well as cholesterol, have specific nephelometric values. To overcome the difficulties caused by the fact that there exists a difference between the

¹ Csonka, F. A., *J. Biol. Chem.*, 1918, xxxiv, 577.

nephelometric values of the constituents of fat extracts, the first thought was to use a mixture for the standard, composed similarly to that of the unknown. The reliability of the result depends upon the extent of our success in reproducing the unknown mixture in the standard. Another suggestion would be to separate the ingredients of the fat extracts, although that would complicate the otherwise simple and rapid method. The ideal modification would be to employ such a technique as would render equal the nephelometric values of the various ingredients; the possibilities of regulating the nephelometric values by the factors referred to above will be demonstrated in the experimental part of this paper.

The present work is merely a preliminary study of the possibilities and as yet does not suggest any one procedure as preferable. The decision as to which of the above suggestions should be applied as the more useful in the nephelometric determination of fat will be considered in a later publication.

Methods.

Oleic acid and cholesterol were selected for the subjects of the present investigations, because they show the largest differences in their nephelometric values. The technique of these experiments, which is similar to that described in a previous article,¹ is such that the conclusions are directly applicable to the technique of Bloor's blood fat determination.

By the method described in the first paper,¹ the turbidity was produced by adding the HCl after the water had been added to the alcoholic solution of the fat; this was Technique A. In Technique B the sequence was reversed, the alcoholic solution of the fat being added to the water, and then the turbidity produced by adding the HCl as previously. In Series 1, oleic acid, cholesterol, and olive oil were used unmodified. In Series 2, the above mentioned substances were put through the saponification procedure by adding 2 cc. of *N* NaOH to the alcoholic solution in a 150 cc. beaker and placing this in a boiling water bath for 15 minutes to insure evaporation to dryness. To the residue were added 4 cc. of alcohol and the whole was warmed carefully to dissolve the fatty material. In those experiments, where the influence of gelatin upon the nephelometric value of oleic acid was studied, the amount of distilled water was substituted by a solution containing 50 mg. of gelatin. The final volume of the solution in which turbidity is produced is 50 cc. with 0.2 *N* acidity (HCl) and containing 4 cc. of 95 per cent alcohol. For comparison a permanent standard was employed, as previously described. Experiment A 1 with oleic acid was repeated many times during this work, as it is very im-

portant to be sure that the intensity of the nephelometric field (permanent standard) remains unchanged throughout. Readings were taken every 5 minutes for $\frac{1}{2}$ hour. The intensity of the nephelometric field used (permanent standard) is equal to the intensity of the turbidity produced by 2 mg. of the oleic acid after a lapse of 5 minutes, with the vernier set at the height of 51.9 mm. (Technique A, Series 1). The nephelometric values were calculated on that basis in all the experiments reported in this paper.

DISCUSSION.

As a result of the investigation described in the previous paper,¹ we conclude that in quantitative determinations it is erroneous to compare materials having different nephelometric values. From the experiments shown in Table I, it is evident that the saponification procedure alters the nephelometric value of the substance, and therefore it is advisable to treat the standard in the same manner as the unknown. In his first publication, Bloor² advocated the use of unsaponified triolein as a standard, later substituting for this oleic acid. By so doing, he overlooked the first source of error and disregarded the second.

The nephelometric value depends upon the conditions under which turbidity is produced; on account of the inconsistent and contradictory behavior of the different substances, the technique which is the more desirable must be previously determined in each individual case. For instance, we find that the nephelometric values of oleic acid and cholesterol in Series 1 are practically the same, whichever technique is employed, while Technique B gives higher values for Series 2. On the other hand, if we compare the result on olive oil³ which was selected to represent the glycerides in general (Table II), we find very little difference in Series 2, while Series 1 shows a pronounced difference; the values being much higher according to Technique A than to B.

By observing the changes of the nephelometric values within certain time intervals, it is interesting to note the difference between the changes shown by oleic acid and cholesterol; namely, the nephelometric value of the former is highest at the first reading and then decreases, while that of the latter shows a con-

¹ Bloor, W. R., *J. Biol. Chem.*, 1914, xvii, 377; 1915, xxiii, 317.

² The olive oil was dissolved in an alcohol-ether mixture for the stock solution.

TABLE II.

Solution tested.	Amount.	Technique.	Turbidity produced.											
			5 min.		10 min.		15 min.		20 min.		25 min.		30 min.	
			Read- ing.	N. V.	Read- ing.	N. V.	Read- ing.	N. V.	Read- ing.	N. V.	Read- ing.	N. V.	Read- ing.	N. V.
Olive oil.....	mg. 2	A1	mm. 51.3	1.01	mm. 56.9	0.91	mm. 60.2	0.86	mm. 62.3	0.83	mm. 65.9	0.79	mm. 68.2	0.76
".....	2	A2	57.5	0.90	63.9	0.81	69.0	0.75	72.3	0.72	76.6	0.68	78.7	0.66
".....	2	B1	61.8	0.84	68.5	0.76	75.0	0.69	80.4	0.65	85.6	0.61	88.6	0.60
".....	2	B2	57.8	0.90	65.3	0.79	70.4	0.74	73.2	0.71	76.6	0.68	81.4	0.64

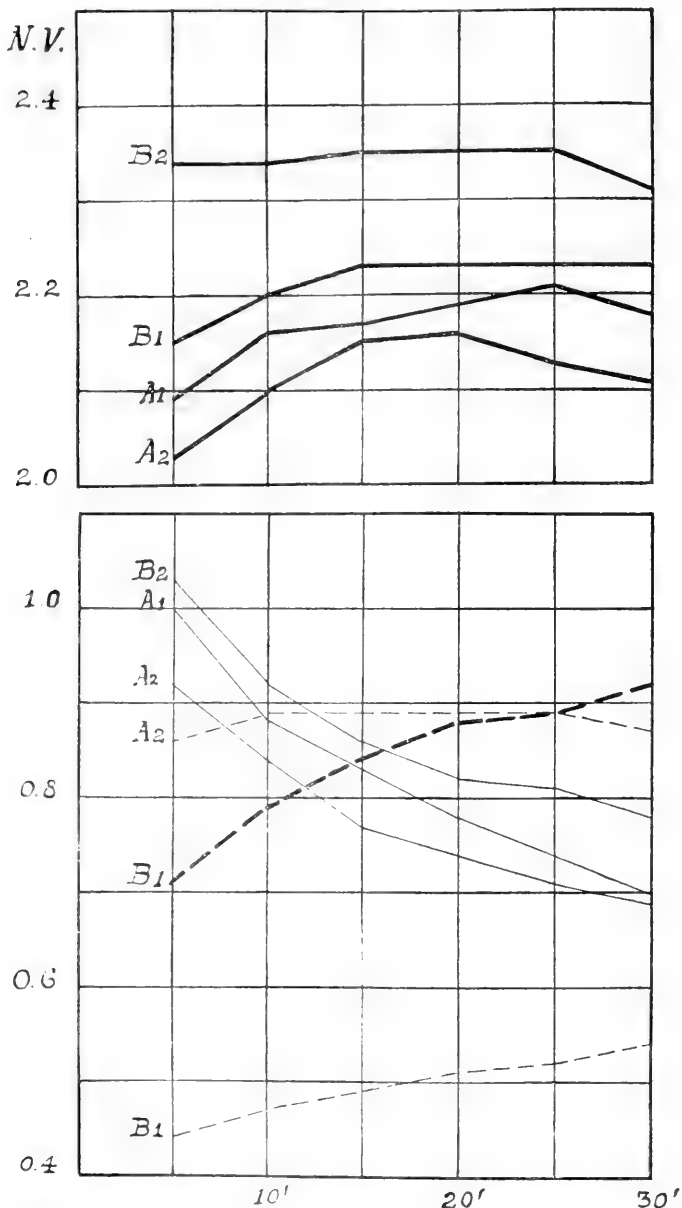

CHART 1. Changes of the nephelometric values (N. V.) within the first half hour.

Cholesterol — Oleic acid —
 " with gelatin - - - " " with gelatin - - -

tinuous increase throughout the 30 minute interval. Chart I presents this variation graphically.

That it is possible to change not only the height, but also the entire direction of the curve is exemplified by the use of gelatin as a protective colloid, as first suggested by Murlin. With oleic acid (Series 1) the nephelometric value is more than 50 per cent lower after a lapse of 5 minutes and while this steadily increases it does not attain its maximum height within the 30 minute interval. In Series 2 the nephelometric values range between narrow limits, and are but slightly lowered. Determinations A1 and B2 were not successful; fairly constant readings could be obtained only in case of A2 and B1. Furthermore, applying Technique A the author was unable to produce a fine suspension of cholesterol in the presence of gelatin, even when the cholesterol was mixed with oleic acid, as the former separated into clumps on the surface. The presence of gelatin decreases the nephelometric value of cholesterol over 60 per cent when the turbidity is produced according to Technique B. A bluish tint is always observed in the nephelometric field whenever gelatin is used, which makes the reading somewhat difficult.

SUMMARY.

Oleic acid and cholesterol were the subjects of investigation. The nephelometric values of these substances were found to be influenced by the saponification procedure as well as by the addition of certain substances which alone, under similar circumstances, do not produce any turbidity. These influencing agents are exemplified by the use of gelatin as a protective colloid.

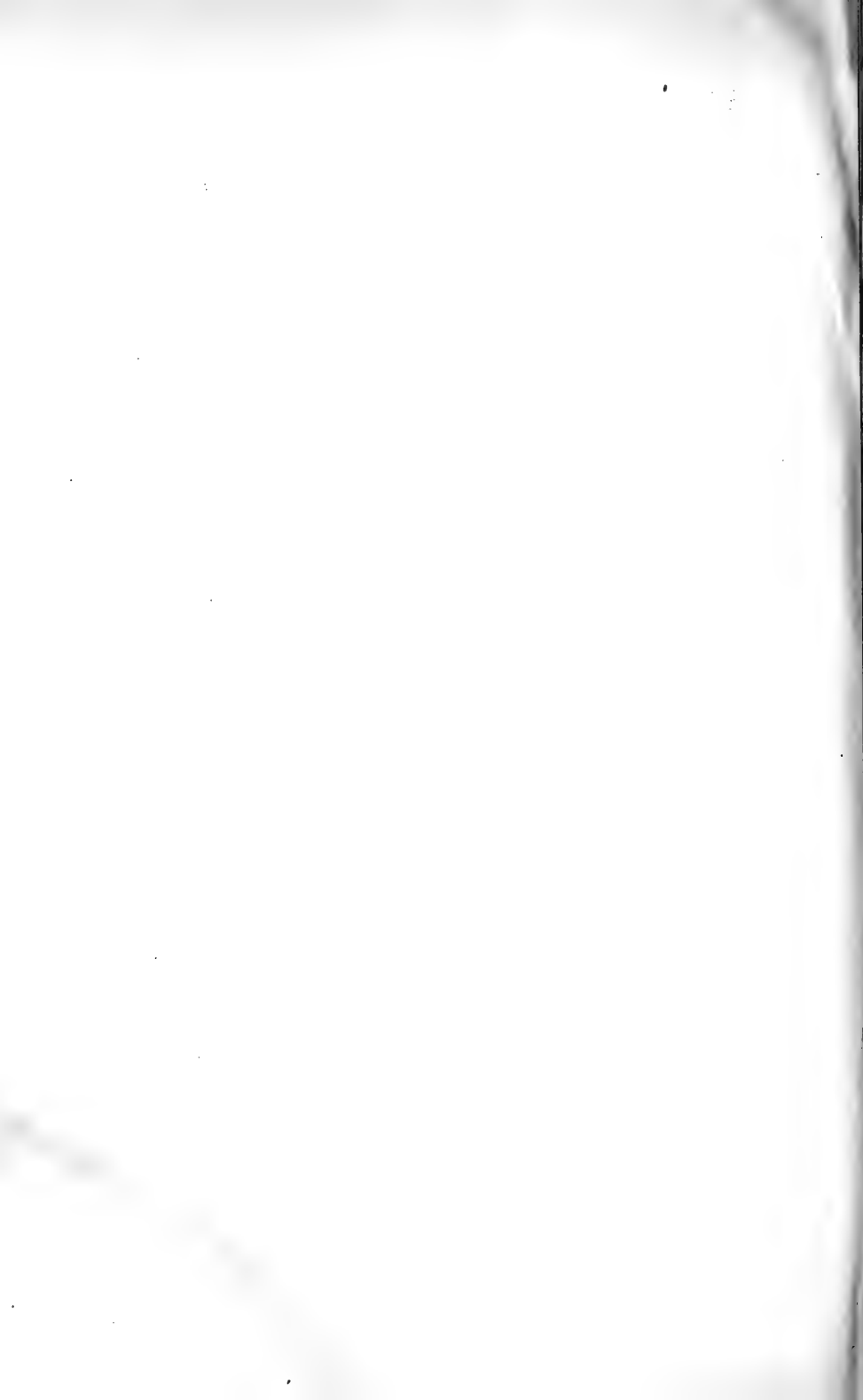

THE HEPTOSES FROM GULOSE AND SOME OF THEIR DERIVATIVES.

BY F. B. LA FORGE.

(From the Bureau of Chemistry, United States Department of Agriculture, Washington.)

(Received for publication, December 31, 1919.)

Of the sixteen theoretically possible heptoses of the *d* series, the following, as well as some of their derivatives, have been prepared and studied; α -glucoheptose,¹ β -glucoheptose,¹ α -mannoheptose,² β -mannoheptose,³ α -galaheptose,³ and β -galaheptose.³ The number of possible heptitols, if optical isomerism is disregarded, obtained by reduction of these sugars is only ten, since the same heptitol may be formed from two different sugars. Thus, Peirce⁴ showed the identity of α -*d*-mannoheptitol with α -*l*-galaheptitol.

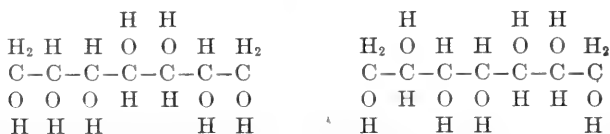

Likewise β -galaheptitol should be identical with one of the heptitols from gulose.

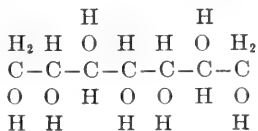

In the present paper the preparation from gulose of two new heptoses and their derivatives will be described and the identity of one of these with β -*d*-galaheptitol established.

¹ Fischer, E., *Ann. Chem.*, 1892, cclxx, 64.

² Fischer, E., and Passmore, F., *Ber. chem. Ges.*, 1890, xxiii, 2226.

³ Fischer, E., *Ann. Chem.*, 1895, cclxxxviii, 139.

⁴ Peirce, G., *J. Biol. Chem.*, 1915, xxiii, 327.

EXPERIMENTAL.

 α - and β -d-Guloheptonic Acids from Gulose.

80 gm. of gulose from the carefully purified hydrazone⁵ were dissolved in 200 cc. of water and slightly more than the calculated amount of hydrocyanic acid was added together with a few drops of ammonia to catalyze the reaction. The solution soon began to warm up, showing that reaction was taking place. After about 8 hours 25 gm. of sulfuric acid, diluted with a small amount of water, were added and the reaction products allowed to stand over night.

The solution was then strongly diluted, 150 gm. of barium hydroxide were added to it, and the ammonia was expelled by boiling. The barium was precipitated by a very slight excess of sulfuric acid and the barium sulfate removed by filtration with suction. The resulting solution contained the mixture of α - and β -guloheptonic acids. These could be obtained as a colorless syrup by decolorizing and evaporating the solution.

Barium Salt of α -Guloheptonic Acid.

For the preparation of this derivative the solution obtained from the above mentioned amount of gulose in 200 cc. of water was exactly neutralized while warm with a concentrated solution of barium hydroxide and then allowed to stand in the ice box. After several days the crystallization of the barium salt was judged to be complete. The yield was about 100 gm. The mother liquor contained the barium salt of the β -acid which will be referred to later. It was recrystallized from about twenty parts of hot water, from which it separates in large colorless plates generally grouped in rosettes.

⁵ The crude gulose obtained by reduction of gulonic lactone with sodium amalgam (Fischer, E., and Piloty, O., *Ber. chem. Ges.*, 1891, xxiv, 521) was dissolved in about eight parts of 65 to 70 per cent alcohol and to this solution was added slightly more than the calculated amount of phenylhydrazine base. Crystallization of the hydrazone began at once and was complete after several hours. The voluminous crystalline mass, which is difficult to filter, was subjected to strong pressure between several layers of filter paper and the resulting press-cake recrystallized from alcohol.

0.3550 gm. of substance gave 0.1402 gm. of BaSO₄.

	Calculated for C ₁₄ H ₂₂ O ₁₁ Ba. per cent	Found. per cent
Ba	23.37	23.22

Its optical activity could not be measured owing to its low solubility but seemed to be very slight.

α-d-Guloheptonic Acid.

The barium salt was dissolved in a convenient amount of hot water, the barium removed quantitatively with sulfuric acid, and the barium sulfate removed by filtration with suction. Upon concentration of the resulting solution the acid was obtained as a colorless syrup which did not crystallize. For reduction to the sugar the syrup was heated for a short time on the steam bath in order to convert as much as possible into the lactone.

Phenylhydrazide of α-Guloheptonic Acid.

This derivative was obtained very easily by heating a concentrated solution of α-guloheptonic acid, with about the theoretical amount of phenylhydrazine, on the steam bath for 1 hour. Upon cooling the reaction product crystallizes out and may be purified by recrystallization from 75 per cent alcohol. It forms long white needles which melt at 191–192°, uncorrected.

2.0656 gm. of substance in 25 cc. of H₂O rotated in a 2 dm. tube with D-light — 5.0° [α]_D²⁰ = — 15.38°.

α-d-Guloheptose.

30 gm. of the mixture of acid and lactone were dissolved in eight to ten parts of cold water and reduced with sodium amalgam.⁶ The reduction required about 200 gm. of 2.5 per cent amalgam. The solution was maintained acid by addition of dilute sulfuric acid from time to time.

The sodium salts were removed by pouring the hot concentrated solution into hot 95 per cent alcohol. The alcoholic solution was concentrated to a syrup, which was again taken up in a large volume of 95 per cent alcohol in order to separate the sugar as far as possible from the sodium salts.

⁶ La Forge, F. B., and Hudson, C. S., *J. Biol. Chem.*, 1917, xxx, 68.

The alcoholic solution was then concentrated *in vacuo* to a small volume.

Crystallization of the sugar took place during evaporation. The yield was very good (9.0 gm.). It may be recrystallized from two parts of hot water or from ten parts of 60 per cent alcohol and forms rosettes of long needles. It is thus much less soluble than most sugars and is only slightly sweet. The sugar melts at 185–187°, uncorrected.

0.7616 gm. of substance in 25 cc. of H₂O rotated in a 2 dm. tube at 20° and D-light after about 8 minutes – 19.5° to the left, after 35 minutes – 14.0°, and became constant at – 11.5°. $[\alpha]_D^{20} = -65.65^\circ$.

0.1703 gm. of substance gave 0.1017 gm. of H₂O and 0.2521 gm. of CO₂.

	Calculated for C ₇ H ₁₄ O ₇ per cent	Found. per cent
C.....	40.00	40.36
H.....	6.66	6.57

α-Guloheptitol.

5 gm. of *α*-guloheptose were reduced with sodium amalgam in the usual manner. The solution was kept slightly alkaline most of the time. When the copper reducing power had practically disappeared, which required 3 days action of the reagent, the reaction product was poured into hot alcohol to remove the sodium sulfate and the solution concentrated to a syrup. This crystallized, on rubbing with absolute alcohol, to a semisolid, waxy mass. After washing with alcohol the product was dissolved in three or four parts of water and hot absolute alcohol added in amount sufficient to produce permanent turbidity.

Under these conditions the compound crystallized in rosettes of hard prisms, which melted at 138–141°, uncorrected. After a second recrystallization it showed no change in melting point.⁷

⁷ Peirce⁴ has prepared *β*-galaheptitol and gives the melting point at 141–144° after the substance had begun to soften at 138°. He states that the melt did not become clear until the temperature was raised to 190°. From the method used by him for the preparation of *β*-galaheptitol, it seems extremely likely that his product may have been contaminated with some of the epimeric *α*-galaheptitol. There seems to be no reason to suppose that *β*-galaheptitol and *α*-guloheptitol are not identical.

0.1009 gm. of substance gave 0.1480 gm. of CO₂ and 0.0682 gm. of H₂O.

	Calculated for C ₇ H ₁₄ O ₇ . per cent	Found. per cent
C	39.60	39.96
H	7.64	7.51

1.3280 gm. of substance in 25 cc. of H₂O showed no rotation in a 2 dm. tube which could be detected.

1.0624 gm. in 25 cc. of saturated aqueous borax solution rotated in a 4 dm. tube with D-light + 0.68° to the right.

β-Guloheptonic Acid and β-Guloheptose.

The filtrate from α-guloheptonic acid barium salt, above referred to, was further concentrated and cooled to cause the separation of as much of the α-compound as possible. The filtrate was diluted, the barium removed quantitatively with sulfuric acid, and the solution of the β-acid, together with some of the α-compound, concentrated to a syrup: This syrup was heated on the steam bath to convert as much as possible of the acid into lactone and then reduced under the conditions already described.

After separation of the sodium salts by means of twice repeated treatment with hot 98 per cent alcohol the sugar was obtained upon evaporation of the solvent as a syrup. This syrup still contained some of the α-compound which could be removed to a large extent by dissolving the mixture in a small amount of glacial acetic acid and allowing the almost insoluble α-sugar to crystallize out.

The syrup resulting after removal of the acetic acid was not entirely pure but was used in this condition for reduction.

Reduction of β-Guloheptose.

The syrupy β-guloheptose was reduced according to the usual method in slightly alkaline solution. The reduction was continued until the copper reducing power of the solution had almost completely disappeared, after which the salts were removed and the reaction product obtained as a syrup. Since this syrup showed no tendency to crystallize, it was transformed into the benzal derivative.

Benzal-β-Guloheptitol.

This derivative was obtained with ease by agitating equal parts of 70 per cent sulfuric acid, benzaldehyde, and the syrupy mixture containing the heptitol. It was washed with water and alcohol and dried at 100°. It melted at about 260° with decomposition.

β-Guloheptitol.

One part benzal-β-guloheptitol was boiled for about 1½ hours with about twelve parts 60 per cent acetic acid. The solution was diluted and excess of the reagent, together with most of the benzaldehyde, was removed by repeated extractions with ether. It was then concentrated to a small volume and again extracted with the same solvent. Upon standing the syrup resulting from evaporation of the final solution deposited crystals of the heptitol which were washed with glacial acetic acid and recrystallized from 95 per cent alcohol. The compound melted at 129°, uncorrected. It was again recrystallized and melted at 128–129°, uncorrected.

0.1025 gm. of substance gave 0.1495 gm. of CO₂ and 0.0653 gm. of H₂O.

	Calculated for C ₇ H ₁₆ O ₇ . per cent	Found. per cent
C.....	39.60	39.98
H.....	7.64	7.09

0.3175 gm. of substance in 5 cc. of saturated aqueous borax solution showed no appreciable rotation in a 1 dm. tube.

STUDIES ON THE SECRETION OF GASTRIC JUICE.

By SEYMOUR J. COHEN.

(From the Laboratory of Pharmacology and Therapeutics, College of Medicine,
University of Illinois, Chicago.)

(Received for publication, December 2, 1919.)

In a previous article (1), on the secretion of gastric juice in fever, it was reported that the concentration of chlorides in gastric juice was constant or slightly reduced. In this present paper I wish to emphasize the relation between the secretion of total chlorides in gastric juice and the secretion of free hydrochloric acid. Most of the data for this paper were obtained at that time but until now have remained unpublished.

The gastric juice was obtained, as previously, from the stomach of dogs with a Pavlov pouch. The animals were kept on a standard diet. Their temperature varied as the result of the production of fever by intravenous injection of solutions of sodium nucleinate or *Bacillus prodigiosus*. The free hydrochloric acid was determined by titrating 1 cc. of the gastric juice with $N/40$ NaOH, dimethylaminoazobenzene being used as indicator. The total chlorides were determined by the method of McLean and Van Slyke (2).

The results given were obtained from 175 chloride determinations of gastric juice on seventeen different animals. The free hydrochloric acidity varied from 0.0 to 0.48 per cent while the total chlorides varied from 0.39 to 0.54 per cent. In examining Charts 1, 2, 3, and 4, it will be noted that the curves for the secretion of free hydrochloric acid do not correspond to the curves for the secretion of total chlorides, although the percentage of total chlorides is always greater than the percentage of free acid, as should be expected. The curve for the total chlorides is almost a straight line with just slight deviations, while the curve for the free acid varies markedly. In some places, however, both curves run nearly parallel, while at other times there is practically no relation between them.

Gastric Juice

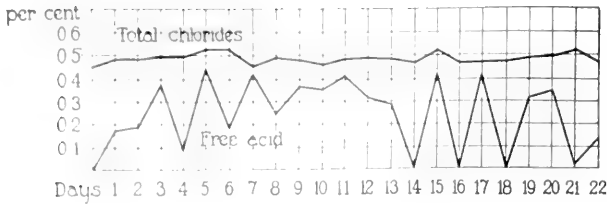

CHART 1. Showing the relation between the secretion of free HCl and the secretion of total chlorides on Dog 2.

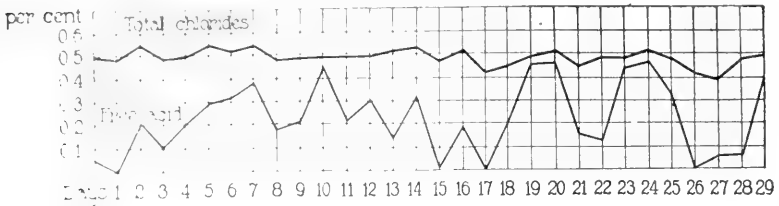

CHART 2. Showing the relation between the secretion of free HCl and the secretion of total chlorides on Dog 5.

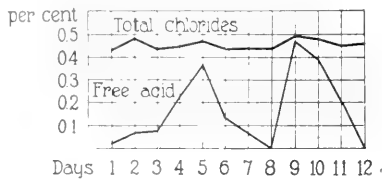

CHART 3. Showing the relation between the secretion of free HCl and the secretion of total chlorides on Dog 20.

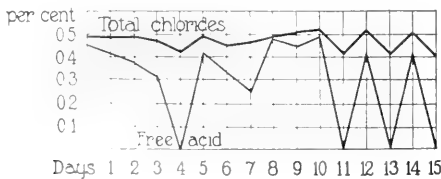

CHART 4. Showing the relation between the secretion of free HCl and the secretion of total chlorides on Dog 22.

From these results it appears that the chlorides of gastric juice are secreted at a more or less constant rate and in all likelihood independently of the hydrochloric acid secretion. In other words you may get just as high a percentage of total chlorides in a sample of gastric juice when the free acidity is 0.0 as when it is 0.35 per cent. This may indicate that the hydrochloric acid is not secreted as such but is probably formed by the secretion of some substance, containing the chlorine ion, which is transformed in the lumen of the stomach or by stomach mucosa to the free acid. This, however, is not a new idea (3). If free hydrochloric acid were secreted as such by the gastric glands, one would expect that with a decrease in the free acidity or a total absence of the free acidity there would be associated with it a marked fall in the total chlorides, but this does not seem to be true. The chlorides are secreted more or less constantly regardless of the free acidity of the gastric juice.

On the other hand, these results may coincide with those of Pavlov (4), and Reh fuss and Hawk (5). Pavlov states that the gastric juice as it flows from the glands possesses a constant acidity; variations are due to secondary neutralization. The apparent constant rate of secretion of chlorides may mean that the gastric juice is secreted with a constant acidity and that the variations in the end-product are due to neutralization by mucus or the alkalinity of the stomach mucosa. This point might be proved by studying a case of achylia and determining the chloride content in the juice; such a case has not been available.

Another factor in the secretion of HCl is the relation between volume and acidity. Pavlov states that, when secretion of the gastric gland is abundant, then the acidity is higher than when the secretion is scant. This is due to the fact that when the juice flows rapidly the acidity is higher, because there is less change of the mucus or alkaline mucosa to neutralize it. This fact is very well illustrated by Charts 5, 6, and 7 in which the volume of gastric juice (5 hours secretion) is charted with the free acidity. It will be noted that free acidity is almost directly proportional to the total volume. This agrees with Pavlov's statement that a large volume of gastric juice, which is secreted rather rapidly, has a higher acidity than a smaller volume, which is secreted more slowly.

Gastric Juice

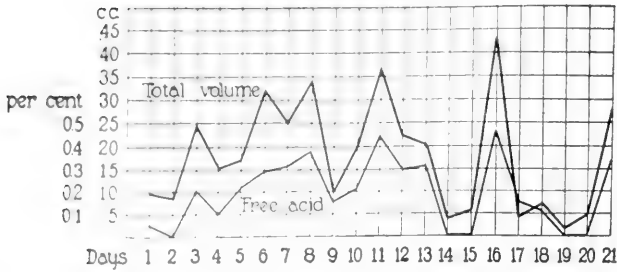

CHART 5. Showing the relation between the secretion of free HCl and the total volume on Dog 2.

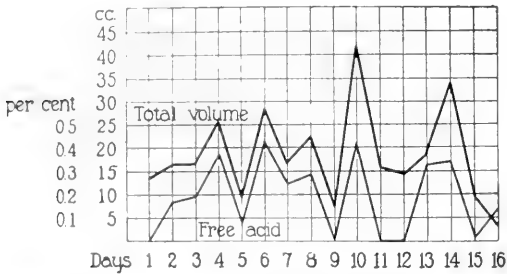

Chart 6. Showing the relation between the secretion of free HCl and the total volume on Dog 5.

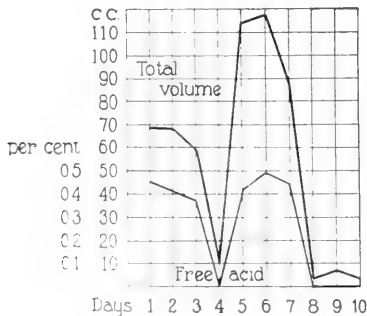

CHART 7. Showing the relation between the secretion of free HCl and the total volume on Dog 22.

SUMMARY.

1. The total chlorides of gastric juice from the dog are secreted more or less constantly regardless of the free acidity of the gastric juice. They vary from 0.39 to 0.54 per cent.

2. This may corroborate Pavlov's view that gastric juice is secreted with a constant acidity and that variations are due to secondary neutralization.

3. A large volume of juice secreted rapidly has a higher acidity than a smaller volume secreted slowly, other factors remaining constant (confirmatory of Pavlov).

BIBLIOGRAPHY.

1. Meyer, J., Cohen, S. J., and Carlson, A. J., *Arch. Int. Med.*, 1918, xxi, 354.
2. McLean, F. C., and Van Slyke, D. D., *J. Biol. Chem.*, 1915, xxi, 361.
3. Mathews, A. P., *Physiological chemistry*, New York, 1916.
4. Pavlov, I. P., *The work of the digestive glands*, London, 2nd English edition, 1910. Translated by W. H. Thompson.
5. Rehfuss, M. E., and Hawk, P. B., *J. Am. Med. Assn.*, 1914, lxiii, 2088.

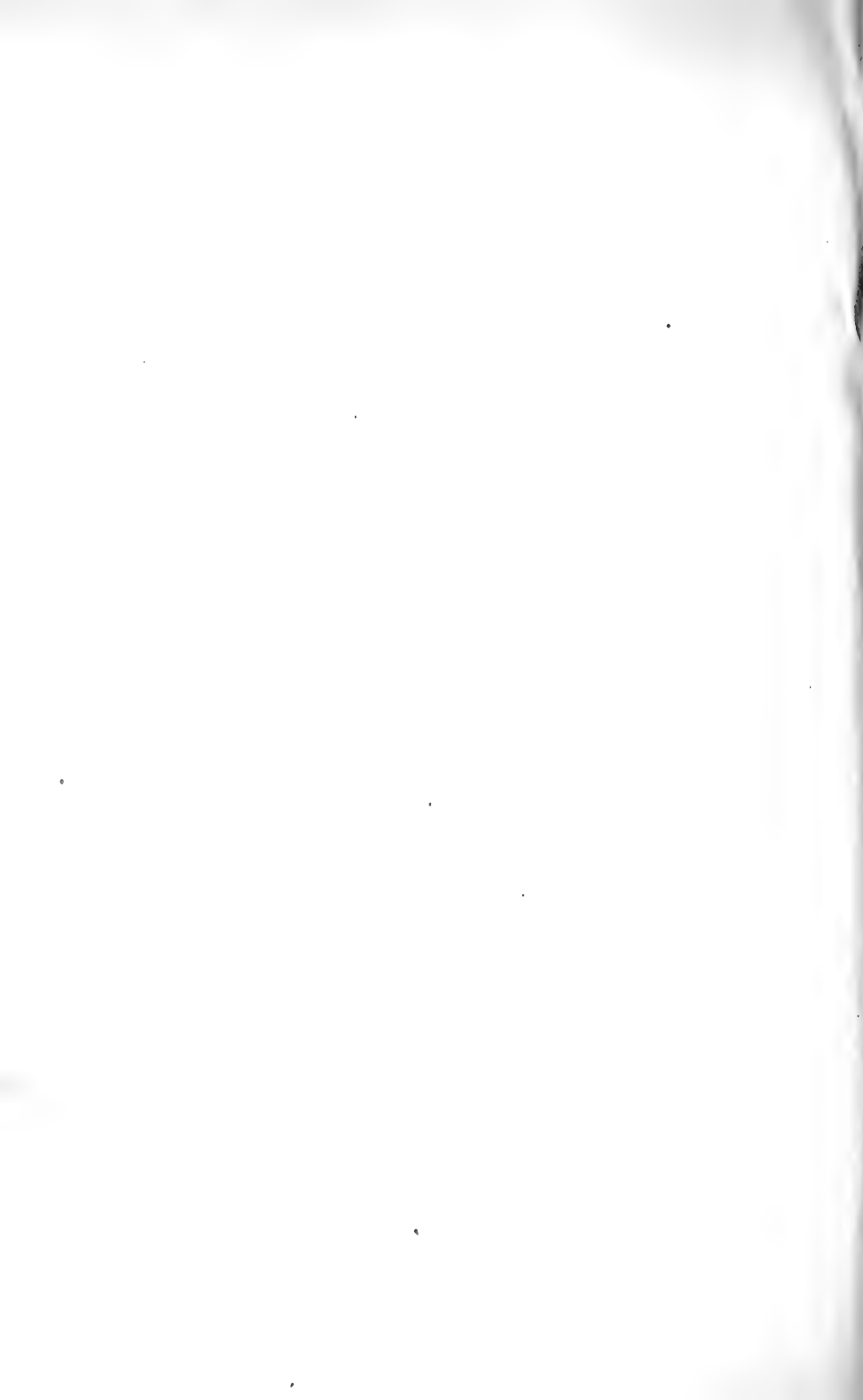

DIRECT QUANTITATIVE DETERMINATION OF POTASSIUM AND SODIUM IN SMALL QUANTITIES OF BLOOD.

By B. KRAMER.

(From the Department of Pediatrics, the Johns Hopkins University, Baltimore.)

(Received for publication, January 2, 1920.)

INTRODUCTION.

When a solution of a cobalt salt in dilute acetic acid is added to a solution of sodium nitrite the following reaction is said to occur:

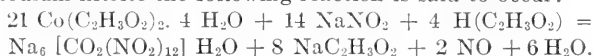

The solution becomes dark brown and oxides of nitrogen are evolved. When these are removed by aeration and a little of the resulting reagent is added to a fairly concentrated solution of any potassium salt containing a little acetic acid, an orange-yellow precipitate is formed at once. The following reaction is presumed to take place (1):

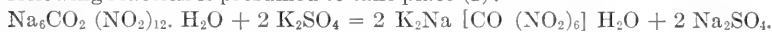

These phenomena were first reported by de Koninek (2) and a few months later by Curtman (3). They observed independently that the reagent does not react with Ca, Mg, Na, Ba, Sr, Zn, Fe, sulfate, nitrate, or chloride ions. It is therefore possible to detect potassium in the presence of these ions. The ammonium ion gives a precipitate with the reagent and phosphates, unless present in very small amounts, will do likewise. Addie and Wood (4) isolated and analyzed the potassium sodium cobalti-nitrite compound formed under definite experimental conditions. They showed that the precipitate has a constant composition represented by the formula $\text{K}_2\text{Na} [\text{Co}(\text{NO}_2)_6] \text{ H}_2\text{O}$, and determined its solubility to be rather a little less than 1 part in 20,000. If the concentration of the potassium salt is not less than 0.5 per cent, the precipitate is formed at once, settles rapidly, and the particles are large enough to be retained by a Gooch filter.

Where it is desired to determine large amounts of potassium as the cobalti-nitrite compound, the method of Addie and Wood (4), that of Drushel (5), or some modification of either may be used (1, 6, 7). The extreme insolubility of the precipitate in water, its sensitiveness under appropriate conditions for minute amounts of potassium, and the indifference of the reagent to other ions usually present in physiological fluids make it suitable for the determination of such small amounts of potassium as are found in blood.

The first attempt to determine potassium in small amounts of blood as the potassium sodium cobalti-nitrite compound was made by Hamburger (8). By his method precipitation is accomplished in a centrifuge tube, the lower end of which is drawn out to a capillary and graduated. The volume of the precipitate is measured in this tube, each graduation being equal to 0.0001 gm. of potassium. The precipitation requires at least 16 hours for completion. No analyses of serum, plasma, or blood are given.

Greenwald (7) has described a composite method for the determination of potassium, sodium, calcium, and phosphates in 90 gm. of blood. The potassium is precipitated as the cobalti-nitrite compound. More recently Clausen (9) reported a method for the determination of potassium in small quantities of blood. The figures reported justify all that the author claims for his method. The precipitation method is essentially that advocated by Drushel. In some preliminary experiments which we performed in 1917 this procedure was tried. In agreement with Bowser (10) it was found that in attempting to concentrate the fluid after adding the reagent decomposition of the precipitate at times took place, resulting in the formation of what appeared to be cobalt acetate. Hence we discarded it for the simpler procedure described below.

The methods described in this paper were devised for the study of changes in the concentration of sodium and potassium in the blood of children. The results of these studies, carried on for more than 2 years, will be published later. In the meanwhile it has been thought desirable to put the methods themselves on record.

Potassium Method.

1 cc. of blood, 3 to 5 cc. of clear plasma, or an equal amount of serum is dried in a platinum dish over the steam bath, then in the incubator at 110°C. for about $\frac{1}{2}$ hour. The dish or crucible is then placed in a flat-bottomed quartz dish, 10 cm. in diameter and 6 cm. deep, in the bottom of which are placed several pieces of porcelain. The outer dish is then heated with the low flame of a large Meker burner until fumes begin to come off. The heating is continued until no more fumes are given off, when the flame is turned on full until the charred material is immobile. The large dish is then covered with a quartz plate and heating continued until the material is completely ashed.¹ The platinum dish is

¹ The ashing often proceeds rapidly at first, then some residual carbon is left which does not readily become oxidized. At this stage the ash is dissolved in a little concentrated hydrochloric acid, evaporated over the steam bath, then dried in the incubator at 105°C., and heated until a white crystalline ash is obtained.

then removed, allowed to cool, and the ash dissolved in 0.5 cc. of water with the aid of one or two drops of glacial acetic acid. 0.5 to 1 cc. of sodium cobalti-nitrite reagent is then added, drop by drop, with stirring and the mixture allowed to stand for at least 10 minutes. During this time a Gooch crucible is prepared. One or two pieces of hardened filter paper are placed at the bottom, then asbestos emulsion is poured in, and the pad sucked dry. When finished the pad should be at least 2 mm. in thickness and should be washed with a large quantity of water. The precipitate is transferred to the wet pad. The suction should be regulated so that the water runs through drop by drop; the rest of the precipitate is washed onto the pad with small portions of cold water. It is then washed repeatedly with small portions of water until the washings return perfectly clear. Precipitate and pad are then transferred *en masse* to a 50 cc. beaker, and the crucible is washed with a little water.² The paper is then removed with a forceps and washed clean with distilled water. Not more than 10 cc. of water need be used for complete transference of asbestos pad and precipitate. 25 cc. (an excess) of 0.01 N potassium permanganate and 5 cc. of 25 per cent sulfuric acid are added. The mixture is stirred, heated over the steam bath for just 3 minutes, and sufficient 0.01 N oxalic acid is then added to decolorize the solution completely. The material is at once titrated back to a permanent pink with 0.01 N KMnO_4 solution. The total number of cc. of 0.01 N KMnO_4 — number of cc. of 0.01 N oxalic acid \times 0.071 = mg. of potassium in the sample.

A blank may be done but the correction is insignificant as a rule.

Details of the Procedure.

Collecting Sample.—Blood is collected by puncture of the median basilic, median cephalic, or external jugular vein. Whole blood is collected directly into a weighed platinum crucible and rapidly weighed. Plasma or serum may be collected under oil as in the Van Slyke and Cullen determination of the CO_2 -combining power of blood plasma (11). To obtain plasma, potassium-free am-

² The pad need not be sucked dry. By means of a glass rod it may be dislodged by a half turn and can then be transferred as a whole including the entire precipitate.

monium oxalate or oxalic acid may be used as anticoagulant. Although ammonium salts react with sodium cobalti-nitrite, the ammonia is completely volatilized during the ashing. To obtain serum, the blood is collected under oil in a centrifuge tube and allowed to remain in the ice box until the serum has separated. If the blood is collected in this manner or in a clean, dry test-tube the danger of hemolysis will be reduced to a minimum.³

Ashing.—The method of ashing which has already been described was first used by Stolte (12). It is simple and fairly rapid. There is no loss of salts through volatilization. Chemically pure potassium or sodium chloride may be thus heated for 48 hours without loss. 1 mg. of potassium similarly treated may be recovered quantitatively. It is important to do such control tests to be sure that the experimental conditions have been duplicated.

Asbestos.—Dilute permanganate solutions when heated on the water bath for some time undergo change. This process is hastened by the presence of asbestos and is not due to organic matter that may be present in the asbestos. (This is all oxidized in a preliminary blank titration.) Nevertheless, if the oxidation is not continued beyond 3 minutes as described, the presence of the asbestos has no influence on the titration. We have found the use of barium sulfate suspension superfluous and its presence makes transference of the precipitate more difficult. Asbestos emulsion may be made by prolonged digestion of a good asbestos with strong nitric and hydrochloric acid for about 8 hours. The asbestos is separated from the supernatant fluid by filtering through a Buchner funnel. It is then washed with water until washings are no longer acid to litmus, then suspended in water, digested with 10 per cent NaOH for an equal period of time, filtered off, washed with dilute hydrochloric acid and then with water, sucked dry, suspended in water, and shaken until a uniform suspension is obtained.

³ Owing to the large amount of potassium present in corpuscles even a moderate amount of hemolysis introduces considerable error.

Preparation of the Reagents.

25 per cent sulfuric acid is made by diluting chemically pure concentrated sulfuric acid with water. It should be tested with permanganate for the presence of organic matter.

The Sodium Cobalti-Nitrite Reagent.—This may be prepared according to the method of Addie and Wood (4). A somewhat easier method is the following, first suggested by Hamburger (8). This yields a less concentrated reagent.

Solution A.—50 gm. of cobalt nitrate crystals (J. T. Baker) are dissolved in 100 cc. of water and to this solution 25 cc. of glacial acetic acid are added.

Solution B.—50 gm. of c.p. sodium nitrite (potassium-free) (J. T. Baker) are dissolved in 100 cc. of water. Mix six volumes of Solution A and ten volumes of Solution B. An evolution of nitric oxide gas occurs at once. Air is drawn through the solution until all the gas has passed off. The reagent is then allowed to stand in the ice box for at least 24 hours. It is best filtered before using.

The cobalt nitrate and sodium nitrite need be weighed only roughly. If kept in the ice box the reagent will keep for at least a month and often much longer. Although 1.5 cc. of reagent will precipitate as much as 20 mg. of potassium (Hamburger), we have found it best to use about 0.5 cc. where 1 mg. of potassium or less is thought to be present. For quantities between 1 to 3 mg., 1 cc. of reagent will suffice.

0.01 N Potassium Permanganate Solution.—0.01 N potassium permanganate solution was prepared from a N or 0.1 N solution by appropriate dilution. The solution was standardized against a known 0.01 N oxalic acid solution. The latter was made from a N oxalic acid solution.

Na, Ca, Mg, Fe, sulfates, chlorides, and nitrate do not interfere. Ammonia must be removed. Although such small amounts of phosphates as occur in normal blood do not interfere with the accuracy of the potassium determination, nevertheless, as has recently been shown (13), the inorganic phosphates may be markedly increased in the blood serum in certain pathological conditions. Hence it may be necessary to remove them (see Table II). The following method has been found satisfactory. The solution

of blood or serum ash acidified with hydrochloric acid is heated on the steam bath for a few minutes. 2 cc. of 2 per cent BaCl_2 solution are added drop by drop followed after a few minutes by 0.5 cc. of concentrated ammonia. 15 cc. of a saturated solution of ammonium carbonate in a mixture of equal volumes of concentrated ammonia and 95 per cent alcohol (14) are added drop by drop with stirring. After $\frac{1}{2}$ hour the precipitate, which contains practically all the barium, calcium, magnesium, sulfate, and phosphate, is filtered through ash-free filter paper and washed several times with the precipitating reagent.

When the filtrate which contains the sodium and potassium has been evaporated to a small volume, a few drops of concentrated hydrochloric acid are added. Evaporation to dryness is continued and completed in the incubator at 110°C . The residue is then heated to constant weight by the method of Stolte and the sodium and potassium are weighed as the chlorides. When combined with the cobalti-nitrite method for potassium, this procedure may be used as a rapid method for the indirect determination of sodium.⁴

Protocols.

Three solutions were made up.

Solution 1 contained 1 mg. of potassium per cc. as chemically pure potassium chloride.

Solution 2 had the following composition:

	<i>gm.</i>
NaCl.....	6.4389
KCl.....	1.4184
$\text{Na}_2\text{HPO}_4 \cdot 2\text{H}_2\text{O}$	2.4992
MgSO_4	0.3695
CaCl_2	0.1836
H_2O up to 1,000.0 cc.	

Solution 3 contained

	<i>gm.</i>
NaCl.....	1.287
KCl.....	0.56
Ca as CaCl_2	0.10
Mg as MgSO_4	0.20
H_2O up to 200.0 cc.	

All chemicals were "Kahlbaum zur Analyse" or prepared by recrystallization of "Baker's Analyzed." $\text{Na}_2\text{HPO}_4 \cdot 2\text{H}_2\text{O}$ was recrystallized and air-dried (17).

⁴ It is also possible to weigh the combined chlorides of sodium and potassium, determine the total chlorine, and calculate the amount of potassium and sodium (15, 16).

TABLE I.
Analysis of Four Samples of Solution 1.

Sample No.	K present.	K found.
	<i>mg.</i>	<i>mg.</i>
1	1.00	0.99
2	1.00	0.98
3	1.00	1.00
4	1.00	1.01

TABLE II.
Analysis of Six Samples of Solution 2.

Sample No.	K present.	K found.*
	<i>mg.</i>	<i>mg.</i>
1	0.74	0.84
2	0.74	0.84
3	2.22	2.45
4	2.22	2.45
5	1.00	1.13
6	1.00	1.07

* The high results are no doubt due to the presence of phosphate. Solution 3 contains same ingredients but no phosphates.

TABLE III.
Analysis of Three Samples of Solution 3.

Sample No.	K present.	K found.
	<i>mg.</i>	<i>mg.</i>
1	1.00	0.98
2	1.00	1.05
3	1.00	1.06

TABLE IV.
Recovery of Potassium Added to Serum.

	K present.	K found.
	<i>mg.</i>	<i>mg.</i>
K in serum.....	0.94	
K added as KCl.....	1.48	
Total.....	2.42	2.39
K in serum.....	0.94	
K added as KCl.....	1.48	
Total.....	2.42	2.42

*Sodium Method.**Introduction.*

The usual method for determining sodium in the presence of other ions is to isolate sodium and potassium as chlorides or sulfates, weigh the combined salts, then determine potassium as the chloroplatinate, the cobalti-nitrite, or the perchlorate, and calculate the amount of sodium from the data thus obtained. Such methods are indirect, very tedious, and obviously cannot be used to determine small quantities.

The general solubility of sodium compounds in the common solvents has tended to discourage attempts to devise a direct sodium method. Fenton (18) found that the sodium salt of dihydroxytartaric acid is insoluble in cold water and used this as the basis for a direct sodium method. Although recommended by Sutton,⁵ the method has not attained any degree of popularity probably because of the difficulty in preparing the reagent and the solubility of the precipitate.

In 1910 Ball (19) described a direct method for the determination of sodium based on the formation of an insoluble sodium cesium bismuthi-nitrite ($9 \text{ CsNO}_2, 6 \text{ NaNO}_2, 5 \text{ Bi(NO}_2)_3$). The reagent is expensive, does not keep well, and large quantities must be used for each determination. The precipitation must be accomplished in a special vessel in the absence of air and requires 48 hours for completion. No suitable washing solution has been found which does not dissolve some of the precipitate.

The use of potassium pyroantimonate for the detection of sodium has been known for a long time. When a solution of this reagent is added to a fairly concentrated solution of a sodium salt, a precipitate is formed, either at once or on standing, which is crystalline in nature and has the composition $\text{Na}_2\text{H}_2\text{Sb}_2\text{O}_7, 6 \text{ H}_2\text{O}$. Precipitation is favored by neutral or slightly alkaline reaction, and is accelerated by the addition of alcohol. The precipitate is very slightly soluble in water. The presence of K, Mg, Ca, SO_4 , PO_4 , or chloride ions does not interfere with the reaction. *Ammonium salts also form an insoluble pyroantimonate and must therefore be removed.*

⁵ Sutton (15), p. 65.

Technique of the Sodium Method.

The ash of 1 or 2 cc. of blood, serum, or plasma obtained as described for the potassium method is dissolved in water, in a platinum dish, using 0.5 cc. of water for each cc. of serum, plasma, or blood. Solution may be aided by the addition of a drop or two of *N* hydrochloric acid. The solution is then made slightly alkaline with freshly prepared 10 per cent KOH solution. 15 cc. of the reagent and one-fifth of the entire volume of absolute alcohol⁶ are then added. Precipitation occurs at once. The mixture is stirred, allowed to stand for at least 2 hours (preferably over night), then transferred to the wet pad of a weighed Gooch crucible as in the potassium method. It is then washed four or five times with 3 cc. portions of 30 per cent alcohol, dried at 110°C., cooled in a desiccator, and weighed. 1 mg. of sodium yields 11.08 mg. of precipitate. All reagents should be tested for the presence of sodium and ammonium salts, especially the potassium hydroxide. A blank determination should be done and the result subtracted from the Na determination in the sample. Most of the laboratory reagents will give a slight precipitate with the potassium pyroantimonate reagent.

Preparation of the Reagents.

Potassium pyroantimonate (J. T. Baker, c.p. analyzed chemicals), 2 gm. of the powder, is added to 100 cc. of boiling water in a 350 cc. Pyrex flask and heating continued until no more dissolves. It is then cooled rapidly under the tap and 3 cc. of 10 per cent KOH are added, and the solution is stirred and filtered. The clear filtrate constitutes the reagent.⁵ Although I have been able to precipitate sodium with a reagent that had been kept in the ice box for 2 months, I have, nevertheless, always prepared the solution fresh each time. The potassium antimonate need be weighed only roughly and the rest of the preparation takes but a few minutes. 10 per cent KOH should preferably be free of both sodium and ammonium salts. Alcohol-washed KOH contains relatively little of these. The exact content, if any is

⁶ The addition of too much alcohol will precipitate some of the reagent which is itself not very soluble and hence the results will be too high.

TABLE V.
Analysis of a Solution of C. P. Sodium Chloride.

Sodium as sodium chloride.	
Present.	Found.
<i>mg.</i>	<i>mg.</i>
5.91	5.87
5.91	6.02

TABLE VI.
*Analysis of Samples of Solution 2.**

Sodium.	
Present.	Found.
<i>mg.</i>	<i>mg.</i>
6.34	6.53
6.34	6.48
6.34	6.40
6.34	6.43

	<i>gm.</i>
*NaCl.....	6.4389
KCl.....	1.4184
Na ₂ HPO ₄ ·2H ₂ O.....	2.4992
MgSO ₄	0.3695
CaCl ₂	0.1836
H ₂ O up to 1,000.0 cc.	

TABLE VII.
Recovery of Sodium Added to Serum.

	Present.	Found.
	<i>mg.</i>	<i>mg.</i>
Sodium in serum.....	14.90	
“ added as sodium chloride.....	6.34	
Total.....	21.24	22.32
Sodium in serum.....	14.90	
“ added as sodium chloride.....	6.34	
Total.....	21.34	21.16
Sodium in serum.....	19.40	
“ added.....	6.34	
Total.....	25.74	25.30

present, should, of course, be determined and a correction made for the amount used. This solution should also be made fresh or kept so that it will neither absorb ammonia nor dissolve sodium.

CONCLUSIONS.

Simple methods for the direct quantitative estimation of sodium and potassium in small quantities of blood, serum, or plasma have been described that are usually accurate to within 3 per cent of the theory and often closer (see Tables I, III, V, and VI).

By using the indirect sodium method described above, both sodium and potassium may be determined on 3 cc. of serum with an error not exceeding ± 5 per cent.

Results obtained by both methods for sodium are in satisfactory agreement.

The potassium content of normal human serum varies between 16 and 22 mg. per 100 cc. of serum. The sodium content has been found in both normal children and adults to vary between 280 and 310 mg. per 100 cc. of serum.

Sodium or potassium added to serum may be recovered almost quantitatively (see Tables IV and VII).

BIBLIOGRAPHY.

1. Bowser, L. T., *J. Ind. and Eng. Chem.*, 1910, i, 791.
2. de Koninck, L. L., *Z. anal. Chem.*, 1881, xx, 390.
3. Cürtman, C. O., *Ber. chem. Ges.*, 1881, xiv, 1951.
4. Addie, R. H., and Wood, T. B., *J. Chem. Soc.*, 1900, lxxvii, 1076.
5. Drushel, W. A., *Chem. News*, 1908, xevii, 124.
6. Green, H. H., *Biochem. J.*, 1912, vi, 69. Greenwald, I., *J. Biol. Chem.*, 1913, xiv, 364.
7. Greenwald, I., *J. Pharm. and Exp. Therap.*, 1918, xi, 281.
8. Hamburger, H. J., *Biochem. Z.*, 1915, lxxi, 415.
9. Clausen, S. W., *J. Biol. Chem.*, 1918, xxxvi, 479.
10. Bowser, L. T., *U. S. Dept. Agric., Bureau of Chemistry, Bull. 152*, 1912, 45-50.
11. Van Slyke, D. D., and Cullen, G. E., *J. Biol. Chem.*, 1917, xxx, 289.
12. Stolte, K., *Biochem. Z.*, 1911, xxxv, 104.
13. Marriott, W. McK., and Howland, J., *Arch. Int. Med.*, 1916, xviii, 708.
14. Bray, W. C., *J. Am. Chem. Soc.*, 1909, xxxi, 623.

15. Sutton, F., Volumetric analysis, Philadelphia, 10th edition, 1911, 144.
16. McCrudden, F. H., and Sargent, C. S., *J. Biol. Chem.*, 1918, xxxiii, 235.
17. Levy, R. L., Rowntree, L. G., and Marriott, W. McK., *Arch. Int. Med.*, 1915, xvi, 389.
18. Fenton, H. J. H., *J. Chem. Soc.*, 1898, lxxiii, 167.
19. Ball, W. C., *J. Chem. Soc.*, 1910, xevii, 1408.
20. Stieglitz, J., Qualitative chemical analysis, New York, 1919, ii, 4.
Roseoe, H. E., and Schorlemmer, C., A treatise on chemistry, London, 5th edition, 1913, ii, 979.

NUTRITIVE VALUE OF THE PROTEINS OF THE BARLEY, OAT, RYE, AND WHEAT KERNELS.*

BY THOMAS B. OSBORNE AND LAFAYETTE B. MENDEL.

WITH THE COOPERATION OF ALFRED J. WAKEMAN.

(From the Laboratory of the Connecticut Agricultural Experiment Station, and the Sheffield Laboratory of Physiological Chemistry, Yale University, New Haven.)

(Received for publication, January 8, 1920.)

Investigators are at present in accord in the conviction that none of the common cereal grains alone or even a mixture of them suffices to afford satisfactory nutrition. The reason for this is to be found primarily in a deficiency in certain of the essential dietary components, notably specific inorganic elements and fat-soluble vitamins. The inadequacy with respect to such needed factors may be complete or partial; in either event nutrition, especially during growth, will be impaired. The particular deficiencies just referred to can readily be offset by supplying otherwise the items needed. The foremost remaining dietary factor in these seeds is the protein. In some of them the proportion of protein calories—the nutritive ratio—is rather low. Furthermore, it has been demonstrated conclusively that some of the individual proteins, like zein (maize), gliadin (wheat), and hordein (barley), for example, are chemically defective and, correspondingly, physiologically inadequate proteins. Hence a misconception of the possible value of the cereals as sources of protein has developed in the minds of some persons owing to their failure to realize that in the form in which these grains are most commonly fed the sum total of their various proteins must be taken into account.

*The expenses of this investigation were shared by the Connecticut Agricultural Experiment Station and the Carnegie Institution of Washington, D. C.

In attempting a further study of the relative nutritive value of the cereal proteins we have already expressed the fundamental view-point as follows:

"The comparison of the cereals, which resemble each other closely in being composed in major part of starch and other carbohydrates and are somewhat alike in respect to the presence or absence of different inorganic nutrients and vitamins, rests in a large measure upon the relative equivalence of their unlike proteins for the uses of nutrition. An ideal comparison, from this standpoint, requires a diet adequate and equivalent in respect to all other essentials, both organic and inorganic, known to constitute a perfect food when suitable protein is supplied therewith."¹

For the white rat which we have employed in these investigations it is essential to have a considerable concentration of protein in the diet if suitable growth is to be attained. This is particularly true when the quality of the protein is somewhat inferior so that relatively large quantities are needed to furnish the indispensable minimum of the limiting amino-acids. Furthermore, if any considerable proportion of other foods is added to furnish the lacking indispensable non-protein factors, the protein content of the resulting dietary mixture becomes correspondingly diluted.

With these facts in mind we attempted to prepare protein concentrates from various cereal grains by removing as much as possible of the starch of the seeds. The preliminary results obtained with such concentrates, supposedly representing the bulk of the total protein in the respective cereals, were not entirely satisfactory.¹ There was an unlike inclusion of indigestible residues—presumably carbohydrates—in the different products; so that these inevitable conditions rendered accurate comparisons on a protein basis somewhat inconclusive.

The concentrates used represented only about 80 per cent of the total proteins of the seed. At that time we thought that in order to get the accurate food intakes which alone permit the drawing of definite conclusions regarding the relative nutritive values of the different proteins, it was necessary to use a food mixture rich in fat. Inasmuch as the cereals are low in protein, the addition of sufficient fat to make the food of the proper consistency increased its calorific value so greatly that too little

¹ Osborne, T. B., and Mendel, L. B., *J. Biol. Chem.*, 1918, xxxiv, 521.

protein was eaten to promote satisfactory growth. In our investigation of the nutritive value of wheat² we found that it was possible to obtain accurate food intakes on diets containing as little as 5 per cent of fat. This was done by adding to the mixture of finely ground wheat, salts, and butter fat enough water to make a dough which the rats would not scatter. This food contained only about 3.75 calories per gm. as compared with our ordinary fat-rich foods which contain on the average about 5 calories per gm. Consequently the animals ate much more liberal quantities of the 5 per cent butter fat food than they did of the fat-rich food, so that although the *percentage* of protein in the former food might be relatively low, the *total* consumption of protein on this food was as great as that on the fat-rich, protein-rich foods ordinarily used. This method, therefore, made it possible for us to study the unchanged total proteins of the various seeds at different protein levels and compare their nutritive value according to the numerical method which we have previously described.³

We have resumed the investigations by feeding the entire cereal grains, finely ground, along with an adequate salt mixture and sufficient butter fat to supply the fat-soluble vitamine. We have assumed, on the basis of evidence obtained by both ourselves and others, that the quantities of the entire cereal grains used by us would supply sufficient water-soluble vitamine.

The method employed in this series of comparative experiments was to feed the finely ground seed mixed with 3 per cent of a suitable salt mixture, 5 per cent of butter fat, and, where necessary, enough corn-starch to make the total protein of the ration 5, 8, or 10 per cent, approximately. In this way the proteins of barley, oats, rye, and wheat were compared.

Each day a little more than enough of the finely ground food for one day's feeding was mixed with a quantity of water sufficient to make a soft dough, and the mixture was packed into the food cups. The next morning the food that remained was dried in an oven. At the end of the week the residues were collected, weighed, and their weight was deducted from that of the dry

² Osborne, T. B., and Mendel, L. B., *J. Biol. Chem.*, 1919, xxxvii, 557.

³ Osborne, T. B., Mendel, L. B., and Ferry, E. L., *J. Biol. Chem.*, 1919, xxxvii, 223.

ingredients fed. Care was taken to make the daily excess of food so small that inaccuracies involved in drying the residues were reduced to a minimum.

Barley.

In preparing the foods intended for the study of the nutritive value of the barley proteins special care was taken to grind the grain, including the husks or glumes, to a very fine powder. The precise composition of the various food mixtures used was as follows:

	10 per cent protein food.	8 per cent protein food.	5 per cent protein food.
	<i>per cent</i>	<i>per cent</i>	<i>per cent</i>
Ground barley.....	92.	72.0-75.5	45-47
Salt mixture*.....	3	3.0	3
Butter fat.....	5	5.0	5
Starch.....	0	20.0-16.5	47-45

*The composition of the salt mixture employed is given in Osborne, T. B., and Mendel, L. B., *J. Biol. Chem.*, 1919, xxxvii, 572.

The results of the feeding experiments with these mixtures, as exhibited in the gains of body weight of growing rats, are shown in Charts I, II, and III.

These experiments leave no doubt of the adequacy of the barley *proteins* as a whole in the nutrition of growth; for several of the rats grew to large adult size without any other source of protein than that derived from this cereal. Some of the animals on the higher percentages of barley protein even surpassed the normal rate of growth on ordinary mixed food. With the lower concentration of barley in the food the deficit of protein appears as a factor limiting the rate of growth, though even on the lowest percentage not inconsiderable gains were made. The possibility of growth upon a diet in which barley supplied the protein was earlier indicated in our experiments with barley concentrates.¹ These tests are less conclusive than the present series because the rations included, during part of the period, a small amount of brewer's yeast containing protein which possibly supplemented the barley protein so as to increase the rate of growth.

In a valuable contribution on the dietary qualities of barley, Steenbock, Kent, and Gross⁴ have reached the conclusion that

“The protein content of barley (13.6 per cent) is too low for continued growth at the normal rate. When reduced in amount to 8.1 per cent, the small amount of growth that results is soon followed by a decline. 5.4 per cent just about suffices for maintenance.

The primary growth determinant in barley is inorganic salts. Of secondary importance, but no less urgent, are protein and fat-soluble vitamins.”

Steenbock, Kent, and Gross⁴ have reproduced the growth curve of one rat (No. 25, Chart 10) which made excellent gains on barley, un-supplemented by other protein. Why their other rats on the same diet did not grow so well is not clear. Our animals ate the rations in liberal amounts, as the food intakes which we have measured indicate.

The composite growth curve published by McCollum, Simmonds, and Parsons⁵ for rats on a diet in which all the protein, amounting to 9 per cent of the ration, was derived from barley also fails to indicate a degree of gain comparable with that attained by our animals on rations containing 8 per cent of barley proteins. It should be noted, however, that our food mixture was not like that of McCollum, Simmonds, and Parsons which contained “seed = to 9 per cent protein; NaCl, 1.0; CaCO₃, 1.5; butter fat, 3.0; dextrin to 100.”

We have not made observations on the total length of life of animals which have grown up upon a diet furnishing proteins from a single seed like barley, or upon their ability to produce and rear young. We believe that there are too many other nutritive factors involved in successful nutrition to enable us, upon the basis of our present knowledge, to charge any failures of nutrition in the second generation to chemical inadequacy of protein solely, although it is quite conceivable that the level of protein metabolism represented by a relatively high or low content of protein in the ration over a long span of life may have a pronounced effect upon the maternal functions. It seems to us,

⁴ Steenbock, H., Kent, H. E., and Gross, E. G., *J. Biol. Chem.*, 1918, xxxv, 61.

⁵ McCollum, E. V., Simmonds, N., and Parsons, H. T., *J. Biol. Chem.*, 1919, xxxvii, 155, see Chart I, p. 164.

however, that if an animal is able to attain adult size upon a diet which furnishes protein from a single source, the nutritive value of this protein is clearly established. Our experiments with barley have demonstrated the possibility of attaining large size where proteins from this source alone were available—provided the total intake of food and consequently of protein and energy was adequate. In view of such positive results, in contrast with the less successful growth obtained in experiments made by others and conducted perhaps under less favorable conditions, it seems hazardous to venture a strict comparison of the nutritional value of proteins from the records of different investigators without more precise information of a quantitative nature regarding the relations of body gain to protein intake where the energy and other essential factors are strictly comparable.

In explanation of the less satisfactory growth observed on the diets containing the lower concentration of barley proteins it might be assumed that a deficiency of water-soluble vitamins, due to the smaller content of the seed in the ration, was the underlying cause. Judging from the evidence secured by Steenbock, Kent, and Gross⁴ regarding the content of water-soluble vitamins in barley, it is not probable that a lack of the latter was the cause of poorer growth in our experiments with diets containing only 5 per cent of barley protein. The rats on the 5 per cent barley protein diets ate as much total food, *i.e.* calories, as those of the same size on the higher concentrations of protein. The quantities probably were as large as the animals could consume. Hence we conclude that the deficiency of protein was the direct outcome of its low content in the ration. We have, however, directed new experiments to the solution of this problem by furnishing a ration low in barley protein but unquestionably adequate in water-soluble vitamins. The diet was the same as in the earlier series, with the addition of approximately 18.6 mg. daily, apart from the food, of a protein-free vitamin preparation from yeast.⁶ This quantity, which supplemented the water-soluble vitamins in the barley already present in the 5 per cent protein food, had been shown in test experiments to be adequate for promoting food intake and growth on our standard food

⁴ Osborne, T. B., and Wakeman, A. J., *J. Biol. Chem.*, 1919, xl, 383.

mixtures. As will be apparent from Chart XIII, recording these experiments, no nutritive advantage accrued from this vitamine

TABLE I.
Barley.

Protein in food.	Rat.	Initial weight.	4 week period.			10 week period.		
			Gain in weight.	Total food intake.	Gain per gm. pro- tein eaten.	Gain in weight.	Total food intake.	Gain per gm. pro- tein eaten.
<i>per cent</i>		<i>gm.</i>	<i>gm.</i>	<i>gm.</i>	<i>gm.</i>	<i>gm.</i>	<i>gm.</i>	<i>gm.</i>
10	5717 ♂	71	69	404	1.7	129	973	1.3
10	5716 ♂	64	64	376	1.7			
10	5701 ♂	72	63	334	1.9	120	950	1.3
10	5251 ♂	66	50	320	1.6	74	764	1.0
10	5709 ♂	70	49	340	1.4	117	983*	1.2
10	5256 ♂	70	43	352	1.2	92	829	1.1
10	5267 ♂	68	37	263	1.4	78	744	1.0
8	5406 ♂	58	78	397	2.5	187	1,178	2.0
8	5407 ♂	74	58	391*	1.9	122	1,090*	1.4
8	5654 ♂	85	57	364	2.0			
8	5649 ♂	71	55	408	1.7			
8	5659 ♂	66	46	297	1.9	114	917	1.6
8	5410 ♂	58	42	328	1.6	86	745*	1.4
8	5662 ♂	76	40	312	1.6	112	964	1.5
5	5427 ♂	74	43	423	2.0	84	1,043	1.6
5	5437 ♂	75	35	337*	2.0	49	807*	1.2
5	5650 ♂	75	33	406	1.6	79	1,091	1.4
5	5432 ♂	69	31	347	1.8			
5	5707 ♂	70	26	311	1.7	64	861	1.5
5	5656 ♂	75	23	316	1.5	49	871*	1.1
5	5661 ♂	67	19	241	1.6	47	645	1.5
5	5423 ♂	66	17	228	1.5	51	630	1.6
Barley + Vitamine.								
5	6211 ♂	70	11	234	0.9			
5	6248 ♂	70	20	328	1.2			

* The records for the food intakes in these experiments were unsatisfactory.

supplement. The food intakes (Rats 6211 and 6248) showed no noteworthy increase; nor was the gain per gm. of protein eaten more favorable (see Table I), hence we must still ascribe the slow

growth on the 5 per cent barley protein ration to the comparatively small quantity of protein afforded by the diet.

Pearled Barley.—We have undertaken a few feeding experiments with pearled barley. This preparation differed from the entire barley kernel in lacking the husks or glumes and the greater part of the outer coats of the seed; *i.e.*, the bran. The food mixture consisted of

	<i>per cent</i>
Pearled barley	92
Salt mixture*	3
Butter fat	5

* The composition of the salt mixture employed is given in Osborne, T. B., and Mendel, L. B., *J. Biol. Chem.*, 1919, xxxvii, 572.

These ingredients were mixed with a little water and baked in an oven.

TABLE II.
Pearled Barley.

Protein in food, <i>per cent</i>	Rat.	Initial weight, <i>gm.</i>	1 week period.		
			Gain in weight, <i>gm.</i>	Total food intake, <i>gm.</i>	Gain per gm. protein eaten, <i>gm.</i>
8	5005 ♂	83	34	302	1.4
8	4961 ♂	76	24	270	1.1
8	5010 ♂	67	13	237	0.7

The outcome of the experiment is shown in Chart IV and Table II. The growth obtained was relatively slight in comparison with the more adequate gains on foods of a similar calorific nature containing 8 per cent of protein from the *entire* barley grain. The addition of vitamines in the form of yeast did not improve the results. It is not unlikely that the milling process has removed fractions of the barley protein, residing in the outer layers of the grain, which supplement the less effective proteins of the barley endosperm. In a similar way it is known that the total proteins of wheat are superior to the proteins of the endosperm of that cereal.

Oats.

In the present series of experiments to ascertain the nutritive value of the oat proteins finely ground, commercial oat groats⁷ were employed in preparing the foods. The various mixtures had the following composition.

	10 per cent protein food.	8 per cent protein food.	5 per cent protein food.
	<i>per cent</i>	<i>per cent</i>	<i>per cent</i>
Oat kernels.....	70	57	35.5
Salt mixture*.....	3	3	3.0
Butter fat.....	5	5	5.0
Starch.....	22	35	56.5

*The composition of the salt mixture employed is given in Osborne, T. B., and Mendel, L. B., *J. Biol. Chem.*, 1919, xxxvii, 572.

The results of the feeding experiments with these mixtures, as exhibited in the gains of body weight of growing rats, are shown in Charts V, VI, and VII.

The successful growth of several of the animals to large size must, we believe, be interpreted to indicate that the total protein of the oat kernel can furnish all the essential nitrogenous units if the intake of food and its concentration of protein are adequate. Very low concentrations of protein in a diet necessitate such large intakes of food to provide enough protein for growth at a normal rate that the energy intake would be inordinately large. Rats will not consume such excesses of food calories; hence, when they satisfy their energy requirement by ingestion of a food relatively poor in protein, growth is slowed in proportion to the quantity (and quality) of the *protein* actually consumed. This is evidently the limiting factor in the experiments with rations containing only 5 per cent of oat proteins.

As a rule our rats for some reason did not eat the oat foods so readily as the barley rations. The food intakes recorded in Tables I and III indicate this. Herein may lie the explanation of the failure of a considerable number to grow well. Some of

⁷ The oat groats were the entire kernels of the oat seed from which the husks or glumes were removed. This material was kindly supplied to us by Mr. Cutting of the Quaker Oats Company.

Protein

TABLE III.

Oat.

Protein in food	Rat.	Initial weight.	1 week period.			10 week period.		
			Gain in weight.	Total food intake.	Gain per gm. pro- tein eaten.	Gain in weight.	Total food intake.	Gain per gm. pro- tein eaten.
<i>per cent</i>		<i>gm.</i>	<i>gm.</i>	<i>gm.</i>	<i>gm.</i>	<i>gm.</i>	<i>gm.</i>	
10	5700 ♂	65	38	248	1.5	80	616	1.3
10	5688 ♂	66	26	215	1.2	83	590	1.4
10	5677 ♂	71	21	202	1.0			
10	5693 ♂	70	21	209	1.0			
8	5428 ♂	70	48	306	2.0	115	824	1.7
8	5433 ♂	58	45	313*	1.8	77	702*	1.4
8	5442 ♂	66	30	246	1.5			
8	5461 ♂	66	22	204	1.3	40	501	1.0
8	5501 ♂	65	21	204	1.3			
8	5486 ♂	58	20	189	1.3	27	438	0.8
8	5464 ♂	69	19	235	1.0	48	638*	0.9
8	5500 ♂	61	19	184	1.3	24	447	0.7
8	5424 ♂	63	17	211	1.0	31	484	0.8
5	5484 ♂	67	36	338	2.1	74	839	1.8
5	5443 ♂	66	29	262	2.2	54	656	1.7
5	5444 ♂	71	27	249	2.2	59	616	1.9
5	5485 ♂	62	24	261	1.8	68	746	1.8
5	5490 ♂	63	22	250	1.8	36	608	1.2
5	5438 ♂	65	21	252	1.7	38	589	1.3
5	5511 ♂	66	21	246	1.7			
5	5429 ♂	80	16	294	1.1	60	746	1.6
Oat + Vitamine.								
5	6206 ♂	69	15	238	1.3			
5	6213 ♂	70	27	226	2.4			
5	6234 ♂	69	25	279	1.8			

* The records for the food intakes in these experiments were unsatisfactory.

our experiments (Rats 5442, 5433, 5461, 5424, 5486, 5500, 5438, and 5490) were terminated without waiting to observe a possible subsequent improvement, because we were primarily concerned at the time with the comparison of the protein efficiency of different cereals under conditions of comparable energy intake.

Our long continued and successful results make the hypothesis of a toxic factor improbable.

It was possible that the content of water-soluble vitamine might be the limiting factor in those cases where the food intake was not large. Experiments by McCollum and his collaborators⁸ indicate that 60 per cent of rolled oats in a mixture similar in energy value to our ration can supply enough of this vitamine to permit good growth. We have, nevertheless, repeated the experiments during a period of 4 weeks by furnishing a ration low in oat protein but unquestionably adequate in water-soluble vitamine.

These trials were comparable to those already described with barley (page 280), the same supply of protein-free yeast vitamine being employed. Chart XIII, as well as the statistical data (Table III), fails to indicate any advantage in the larger intake of water-soluble vitamine, so that the results with the 5 per cent oat protein food must be ascribed to the comparatively small content of protein in the diet.

McCollum⁹ and his associates have recorded numerous observations upon the dietary value of the oat kernel. He states:

"We have not yet been able to supplement oats with purified food ingredients and attain optimum results, when the oat kernel constituted from 70 to 80 per cent of the food mixture. Gelatin combined with oat proteins forms a much better protein mixture than do casein and oat proteins. . . . We have not yet determined the cause, but it is evident that a high intake of oats over a long period causes injury to the rat. This is true also for the cow, and I believe also for swine."¹⁰

Our experience with respect to the value of casein and gelatin respectively has been recorded elsewhere.¹

Why we have obtained very considerable growth upon oat diets containing 5 per cent of protein whereas McCollum and

⁸ McCollum, E. V., Simmonds, N., and Pitz, W., *J. Biol. Chem.*, 1916-17, xxviii, 492; 1917, xxix, 341.

⁹ McCollum, E. V., *J. Am. Med. Assn.*, 1917, lxxviii, 1379. McCollum, E. V., Simmonds, N., and Pitz, W., *J. Biol. Chem.*, 1916-17, xxviii, 483; 1917, xxix, 341. McCollum, E. V., and Simmonds, N., *J. Biol. Chem.*, 1917, xxxii, 347. McCollum, E. V., *The newer knowledge of nutrition*, New York, 1919, 163.

¹⁰ McCollum, E. V., *J. Am. Med. Assn.*, 1917, lxxviii, 1379.

Simmonds¹¹ rarely secured maintenance upon foods of essentially similar energy content containing either 4.5 or 6.75 per cent of oat proteins (see their Chart 7) is not clear. The only conspicuous difference in the rations fed lies in the use of starch in our diets instead of dextrin and agar in the food mixtures used by McCollum and Simmonds. Their experiments in which large supplements of casein or other proteins were used have less significance in estimating the comparative value of the different cereal proteins; the quantities of the supplementary protein employed have presumably in themselves been sufficient to promote growth independently of the cereal protein used. The confusion now existing in the literature of nutrition regarding the rôle of the oat proteins *per se* (aside from any possible detrimental factor in the kernel as a whole) may be attributed to the conflicting statements published. Thus we read in one place, "The oat kernel seems to contain proteins of a poorer quality than either the maize or wheat kernel."¹² Again we read,

"The protein of the oat kernel has a slightly higher value for growth than has that of either wheat or corn, but the amount furnished by 90 per cent of rolled oats is below the optimum for the support of growth in a rapidly growing species."¹³

Or again we are told that "the oat proteins are distinctly better than those of wheat, maize, or rice."¹¹

In a recent report from the Agricultural Experiment Station of the University of Wisconsin, referring to the effect of organic nutrients on animal growth and reproduction, it is stated:

"In every case where the oat plant was fed miserably poor offspring has resulted; for instance, with oatmeal and oat straw and butterfat; oatmeal, casein, butterfat and oat straw. This would seem to indicate that the trouble is not due to the poor protein or low vitamine content, but is a matter of actual deficiency in the mineral elements in the ration. Where the ration has been fortified with either calcium acetate or wood ashes, normal offspring has resulted. Further experiments are necessary to con-

¹¹ McCollum, E. V., and Simmonds, N., *J. Biol. Chem.*, 1917, xxxii, 362.

¹² McCollum, E. V., Simmonds N., and Pitz, W., *J. Biol. Chem.*, 1917, xxix, 342.

¹³ McCollum, E. V., *The newer knowledge of nutrition*, New York, 1919, 163.

firm this, but it is probably true that the main mineral constituent which is lacking is calcium. . . . Oats fed with corn stover and other roughages carrying a high calcium content gave no trouble whatever."¹⁴

We shall, therefore, refer later to the indications offered by our own strictly comparable tests of the comparative growth-promoting value of different cereals.

Rye.

For the experiments to ascertain the nutritive value of the rye proteins the finely ground entire kernels were employed in food mixtures of the following composition.

	10 per cent protein food.	8 per cent protein food.	5 per cent protein food.
	<i>per cent</i>	<i>per cent</i>	<i>per cent</i>
Whole rye.....	80.0-85.4	64.0-69.5	40.0-42.7
Salt mixture*.....	3.0	3.0	3.0
Butter fat.....	5.0	5.0	5.0
Starch.....	12.0-6.6	22.5-28.0	49.3-52.0

* The composition of the salt mixture employed is given in Osborne, T. B., and Mendel, L. B., *J. Biol.Chem.*, 1919, xxxvii, 572.

The results of the feeding experiments, exhibited in gains of body weight of growing rats on these mixtures, are shown in Charts VIII, IX, and X, and Table IV.

Out of all these trials with male rats, only three, Nos. 5447, 5446, 5465, have reached a body weight of 200 gm. Many of the rats, notably those on the foods containing the higher percentages of rye, have grown well for a considerable period, during which their food intakes, as recorded later in this paper, were reasonably large and, as will be subsequently shown, the efficiency of the proteins for growth was comparable with that of the other cereal proteins included in the present study. Had our investigations been confined to a few weeks or months we probably should have failed to realize the exceptionally large mortality which subsequently involved our rye-fed animals. It is unlikely that these untoward results are due to some intercurrent disease prevalent

¹⁴ Russell, H. L., and Morrison, F. B., *Univ. Wisconsin Agric. Exp. Station, Bull.* 302, 1919, 55.

TABLE IV.

Rye.

Protein in food.	Rat.	4 week period.				10 week period.		
		Initial weight.	Gain in weight.	Total food intake.	Gain per gm. pro- tein eaten.	Gain in weight.	Total food intake.	Gain per gm. pro- tein eaten.
<i>per cent</i>		<i>gm.</i>	<i>gm.</i>	<i>gm.</i>	<i>gm.</i>	<i>gm.</i>	<i>gm.</i>	<i>gm.</i>
10	5733 ♂	67	48	308	1.6	105	739	1.4
10	5737 ♂	71	33	275	1.2	84	723	1.2
10	5732 ♂	70	30	235	1.3	84	651	1.3
10	5731 ♂	71	30	288	1.0	69	686	1.0
8	5447 ♂	82	44	328	1.7	102	884	1.4
8	5522 ♂	67	43	295	1.8	73	688	1.3
8	5524 ♂	74	42	291	1.8	76	724	1.3
8	5448 ♂	69	37	304	1.5	75	728	1.3
8	5487 ♂	82	36	320	1.4	60	699	1.1
8	5523 ♂	75	34	304	1.4	68	709	1.2
8	5449 ♂	76	27	277	1.2	81	711	1.4
8	5446 ♂	84	26	287	1.1	77	734	1.3
5	5553 ♂	71	34	344	2.0	57	882*	1.3
5	5552 ♂	74	20	339	1.2			
5	5462 ♂	75	19	320	1.2	55	763	1.4
5	5465 ♂	73	19	293	1.3	51	737	1.4
5	5557 ♂	66	19	288	1.3	44	830	1.1
5	5556 ♂	69	18	249	1.4	39	718	1.1
5	5474 ♂	71	17	245	1.4	42	600	1.4
5	5472 ♂	69	17	274	1.2	44	669	1.3
Rye + Vitamine.								
5	6223 ♂	70	21	283	1.5			
5	6226 ♂	69	17	278	1.2			
5	6224 ♂	70	15	274	1.1			

*The records for the food intakes in these experiments were unsatisfactory.

in our colony, because in that event a comparable number of deaths might have been expected among the other groups of cereal-fed animals simultaneously being investigated. The seemingly good nutrition of the rye-fed animals in the earlier periods of their life makes it unlikely that the proteins *per se* are chargeable with the untoward results subsequently exhibited by this

group of animals as a whole. What other deleterious factor, if any, may be present we are as yet unable to state.

It is not likely that the poor growth secured on the 5 per cent rye protein mixtures was due to a lack of water-soluble vitamine, inasmuch as the special series of experiments wherein 18.6 mg. of protein-free vitamine preparation from yeast were supplied daily yielded no better results (Chart XIII). The low protein content of the ration was evidently the limiting factor in growth.

The only comparable experiments which we have discovered in the literature are by McCollum, Simmonds, and Parsons⁵ who state:

“ . . . such cereal grains as maize, rye, and barley contain proteins of such values that when fed at 9 per cent of the food mixture, supplemented with respect to certain salts and fat-soluble A, young rats are able to grow at approximately half the normal rate.”

In the composite growth chart of male animals, presented by these authors, a body weight of 200 gm. was attained. In further experiments in which rye, to the extent of 50 per cent (equivalent to 6 per cent of protein from rye) of the ration, was supplemented by flaxseed oil meal or millet seed as a further source of protein, females grew fairly well and produced young.¹⁵ The diet was regarded as not quite satisfactory because of “the poor quality of its proteins, and shortage of fat-soluble A.” Nevertheless these animals received in the diet 2 per cent of butter fat, a quantity which McCollum reports elsewhere¹⁶ “to be sufficient for the maintenance of good growth when all other dietary factors are of good quality.” The only further reference to the rye proteins which we have noted is the statement of McCollum, Simmonds, and Parsons¹⁷ according to which

“ . . . it appears that rye and flaxseed proteins in this proportion [rye proteins 6 per cent, flaxseed proteins 3 per cent] are nearly if not quite equal in value for growth to the proteins of milk.”

¹⁵ McCollum, E. V., *The newer knowledge of nutrition*, New York, 1919, 175.

¹⁶ McCollum, E. V., Simmonds, N., and Parsons, H. T., *J. Biol. Chem.*, 1919, xxxvii, 162.

¹⁷ McCollum, E. V., Simmonds, N., and Parsons, H. T., *J. Biol. Chem.*, 1919, xxxvii, 160.

Wheat.

The wheat mixtures used in these experiments were prepared from the whole wheat kernel ground in the laboratory. They had the following composition.

	10 per cent protein food.	8 per cent protein food.	5 per cent protein food.
	<i>per cent</i>	<i>per cent</i>	<i>per cent</i>
Whole wheat.....	92	70	51
Salt mixture*.....	3	3	3
Butter fat.....	5	5	5
Starch.....	0	22	41

* The composition of the salt mixture employed is given in Osborne, T. B., and Mendel, L. B., *J. Biol. Chem.*, 1919, xxxvii, 572.

That growth to large adult size can be completed at a normal rate on the food containing 92 per cent of wheat has already been demonstrated by us.¹⁸ Several litters of young were secured from females on this diet. The growth of rats kept on the wheat food of lower protein content is shown in Charts XI and XII. Several of the experiments with 8 per cent wheat protein were terminated after a few weeks of observation without reference to the final outcome. The growth of the remainder, though fairly vigorous at first, soon slowed.

The young rats of the second generation on the 10 per cent wheat protein food¹⁹ failed to grow with normal vigor. Thus of one litter from Rat 4681 ♀, three young, 5075♂, 5076♂, 5077♂, died at the ages of 6, 8, and 12 months respectively without having attained a maximum weight of more than 75, 75, and 62 gm. respectively. All the young of a second litter died at an early age. Out of a litter from Rat 4577 ♀, two died very young and 5325 ♀, 5326 ♀, 5327 ♀, 5328 ♀, 5330♂, and 5331♂ survived for some time, having reached a maximum body weight of 107, 45, 57, 32, 40, and 48 gm., at 270, 88, 117, 102, 151, and 137 days

¹⁸ Osborne, T. B., and Mendel, L. B., *J. Biol. Chem.*, 1919, xxxvii, 557, Chart II.

¹⁹ The curves of growth of Rats 4577 and 4681, which bore these young, have been published. Osborne, T. B., and Mendel, L. B., *J. Biol. Chem.*, 1919 xxxvii, 557, Chart II.

TABLE V.
Wheat.

Protein in food.	Rat.	Initial weight.	4 week period.			10 week period.		
			Gain in weight.	Total food intake.	Gain per gm. pro- tein eaten.	Gain in weight.	Total food intake.	Gain per gm. pro- tein eaten.
<i>per cent</i>		<i>gm.</i>	<i>gm.</i>	<i>gm.</i>	<i>gm.</i>	<i>gm.</i>	<i>gm.</i>	<i>gm.</i>
10	4669♂	60	45	322	1.4	114	810	1.4
10	4689♂	63	44	322	1.4	102	823	1.2
10	4680♂	68	39	287	1.4	92	784	1.2
8	5463♂	66	40	345	1.4	84	873	1.2
8	5469♂	65	35	346	1.3	77	873*	1.1
8	5381♂	62	34	332	1.3	83	848	1.2
8	5470♂	67	33	323	1.3	78	815	1.2
8	5382♂	67	28	274	1.3			
8	5457♂	62	23	234	1.2	46	596	1.0
8	5375♂	61	20	275	0.9	52	753	0.9
5	5711♂	76	18	289	1.2	41	714	1.1
5	5694♂	66	14	262	1.1	31	600	1.0
5	5676♂	71	9	254	0.7	29	606	1.0
5	5690♂	69	7	237	0.6	29	547	1.1
5	5416♂	61	4	207	0.4			
5	5415♂	65	4	211	0.4			
5	5399♂	76	4	271	0.3			
5	5398♂	71	4	242	0.3			

Wheat + Vitamine.

5	6227♂	69	25	264	1.9			
5	6229♂	70	22	317	1.4			
5	6222♂	70	7	242	0.6			

* The records for the food intakes in these experiments were unsatisfactory.

respectively. Whether this outcome was due to a protein deficiency—which seems less likely—or to some other factor cannot be decided with certainty at present. McCollum, Simmonds, and Pitz²⁰ also state that they have not been able to make up a ration containing wheat proteins only which was adequate for

²⁰ McCollum, E. V., Simmonds, N., and Pitz, W., *J. Biol. Chem.*, 1916-17, xxviii, 211.

rearing of the young. They add: "Over a wide range of protein content growth approximated the normal, but pronounced injurious effects of the ration were revealed in the reproduction records only." Some of the young (see their Chart 9) appeared normal except for their diminutive size. We have had a similar experience.²¹ Incidentally we may note, however, that we have successfully raised a third generation of fertile rats on a diet in which the protein was derived solely from commercial wheat embryo.²²

Whether the slow growth of the rats on diets containing only 5 per cent of wheat protein was due to a lack of water-soluble vitamine in the 51 per cent of wheat contained in the food mixtures can be judged by comparison with the further results obtained by furnishing a ration equally low in wheat protein, but unquestionably adequate in water-soluble vitamine. This was derived from additions of 18.6 mg. per day of protein-free vitamine preparation from yeast and employed as in the experiments with 5 per cent barley proteins (page 280). If one may judge from the food intakes and increments of body weight (Table V and Chart XIII)—which were essentially of the same order as those in the other 5 per cent wheat protein food series—the limiting factor in the wheat protein trials is to be found in the low protein content of the ration.

The Comparative Nutrient Efficiency of the Entire Proteins of the Barley, Oat, Rye, and Wheat Kernels.

The growth of our rats, on diets essentially comparable except in respect to content and source of the cereal *proteins* contained therein, show the possibilities of nutrition when any one of four commonly used cereal grains furnished the protein. To formulate a tenable comparison of the relative nutritive value of these proteins in growth it is necessary, as we have frequently pointed out before, to know the food intake. The criteria for such experiments have already been discussed elsewhere by us.³

²¹ Osborne, T. B., and Mendel, L. B., *J. Biol. Chem.*, 1919, xxxvii, 596.

²² The food mixtures and history of the parent animals are described in Osborne, T. B., and Mendel, L. B., *J. Biol. Chem.*, 1919, xxxvii, 557, Chart XIV.

The tabular summaries give the essential facts in the case of those animals for which the data are reasonably accurate. In many trials, particularly with the wheat mixtures, so many animals spilled food as to render the statistics for food intake incomplete; hence they have been rejected in every case. The figures recorded are the selected residual complete data from a large number of trials. The growth results have been calculated from animals beginning at a body weight of about 70 to 80 gm. Calculations have been made to include the subsequent first 4 weeks; and likewise the first 10 weeks, during which a rat normally more than doubles its body weight. The composition of the foods from the standpoint of calorie value was substantially the same, starch being substituted for cereal whenever the content of the latter was reduced in the ration; hence the energy intake in the experiments with foods containing different protein concentrations must have been practically proportional to the total intake of food. The graphic records of the body weights of all these animals will be found in Charts I to XIII.

If the figures representing gains per gm. of protein eaten are contrasted for the first periods of 4 weeks a slight advantage might seem to accrue to the barley proteins. This advantage is scarcely apparent, however, when the longer period (10 weeks) is taken into account. Obviously the number of trials is far too small to permit the use of such limited statistics for computation of averages. Until a far greater refinement of the method is secured it would appear, on the whole, that the proteins of the four cereals studied are not widely different in their efficiency in promoting growth. In contrasting the different groups of animals from a standpoint of their subsequent history, however, it seems as if the barley-fed animals have, if anything, grown best.

The comparative equality of the four types of cereal proteins just recorded becomes the more striking when the gains which they promote per gm. of protein consumed are contrasted with those secured within comparable periods of growth by the use of proteins from other sources. Thus, in feeding rats of similar initial weight for periods of 8 weeks, gains per gm. of protein eaten amounted to more than 2.3 gm. for lactalbumin and 1.7 gm. for casein. The advantage of the addition of more efficient supplementary protein to the cereal protein has been discussed elsewhere.²

In somewhat similar experiments on the comparative nutritive value, in growth, of proteins of wheat endosperm (flour and wheat gluten) with and without supplements of animal protein (meat, milk, egg), the best gains per gm. of protein eaten were not much larger, during a 4 week period, than those here reported for the four cereals. The outcome with the wheat endosperm proteins alone was decidedly poorer, as the following summary shows.

Summary.*

	Per cent of protein in food.	Gain of body weight per gm. of protein.
		<i>gm.</i>
Flour + egg.....	14.8	2.00
	10.3	1.80
“ + milk.....	14.8	1.67
	10.3	1.73
“ + meat.....	14.8	1.73
	10.3	1.47
“ + “ + yeast.....	10.3	1.66
“ + gluten.....	14.8	0.50

* Quoted from Osborne, T. B., and Mendel, L. B., *J. Biol. Chem.*, 1919, xxxvii, 584.

We were surprised to find that the *efficiency* of the *entire* wheat kernel, as well as that of the other cereal grains studied, without supplementary proteins, was so far superior to that ascertained by us earlier in the study of the *endosperm*. The utilization data secured by us testify to the unexpected availability for growth of the proteins of these whole cereals. This is in harmony with the recent findings of Sherman and his collaborators²³ in the study of the maintenance metabolism of adults as shown by nitrogen balance experiments on diets in which the proteins of oats and maize contributed a large portion of the protein intake. They assert:

²³ Sherman, H. C., Wheeler, L., and Yates, A. B., *J. Biol. Chem.*, 1918, xxxiv, 383. Sherman, H. C., and Winters, J. C., *J. Biol. Chem.*, 1918, xxxv, 301. Sherman, H. C., Winters, J. C., and Phillips, V., *J. Biol. Chem.*, 1919, xxxix, 53.

“ the proteins of oats and maize are of virtually equal nutritive efficiency; and this is true whether the proteins in question constitute practically the sole nitrogenous food or are supplemented by a constant small amount of milk protein. That nitrogen equilibrium was maintained with such low protein intake in the latter experiments, and was so closely approached in the former, shows that the proteins of both maize and oatmeal were very efficiently utilized in the maintenance metabolism of these healthy adults. . . . For the purposes of practical dietetics equal weights of oat and maize proteins may be regarded as essentially equal in value, and even the minimum amount of milk which can possibly be regarded as permissible in the light of our present knowledge of nutrition, will apparently so supplement the proteins of either the maize or oat kernel as to make them function with an efficiency comparable with that of the average protein of mixed diet in the maintenance metabolism of man.”

The ideal of equivalent calorie intakes during comparable periods of time in the growth experiments to compare the efficiency of proteins from different sources has by no means been realized in the trials which we have recorded in this paper. At best our experiments show the possibility of normal growth for long periods where no other proteins than those furnished from these cereals are available. They also indicate a surprisingly good efficiency in the most favorable experiments; but inasmuch as many ultimate failures of growth and well being, and numerous deaths, were encountered in the later periods of many of the experiments with some of these cereals it will be necessary to take into account such unknown factors as may have been responsible for these ultimately unfavorable results. We have observed sufficient, successful, prolonged growth in the case of all the cereal studies to make it unlikely, not to say improbable, that the protein factor is responsible for this untoward outcome of many of the cereal experiments.

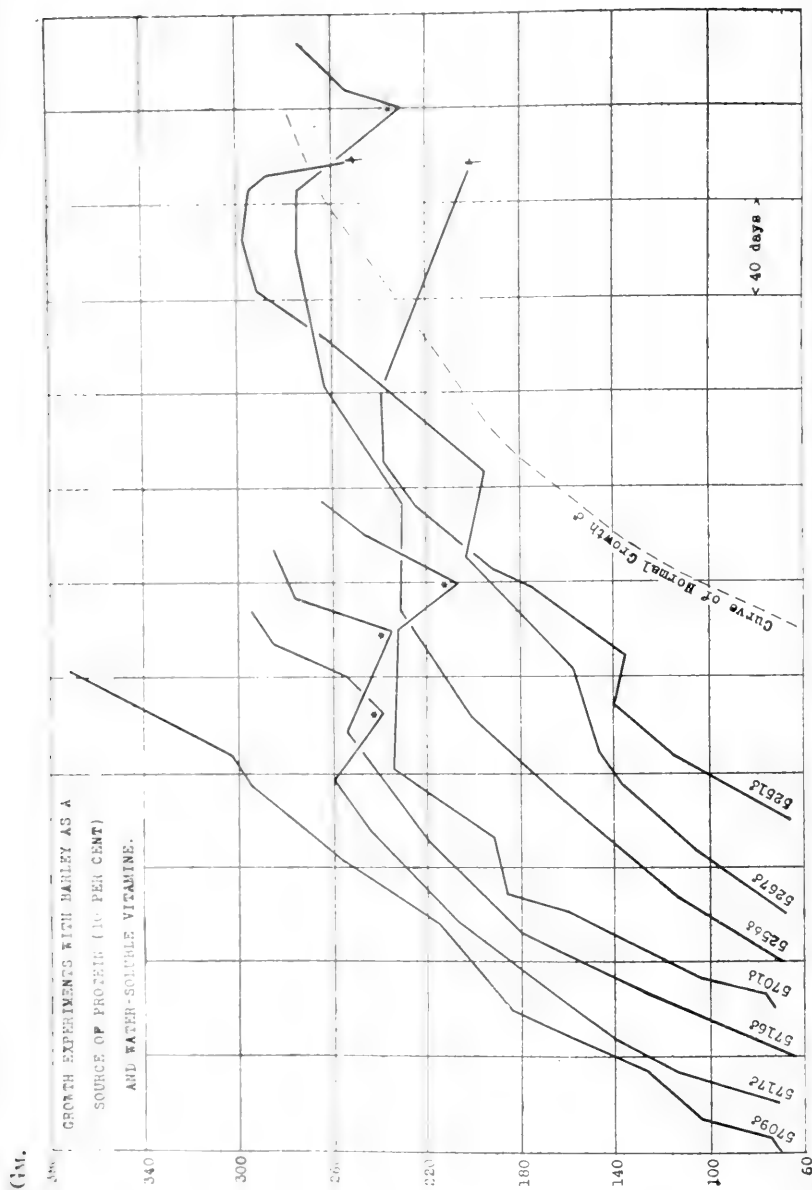

CHART I. Showing the growth of rats on an otherwise adequate diet in which all the protein (10 per cent) and the water-soluble vitamins were furnished by barley, which formed 92 per cent of the food mixture. The asterisks (*) indicate the beginning of the period when the chaff was mostly removed by sifting the barley during grinding, whereupon the animals appeared to eat the food more greedily, with resulting increments in body weight.

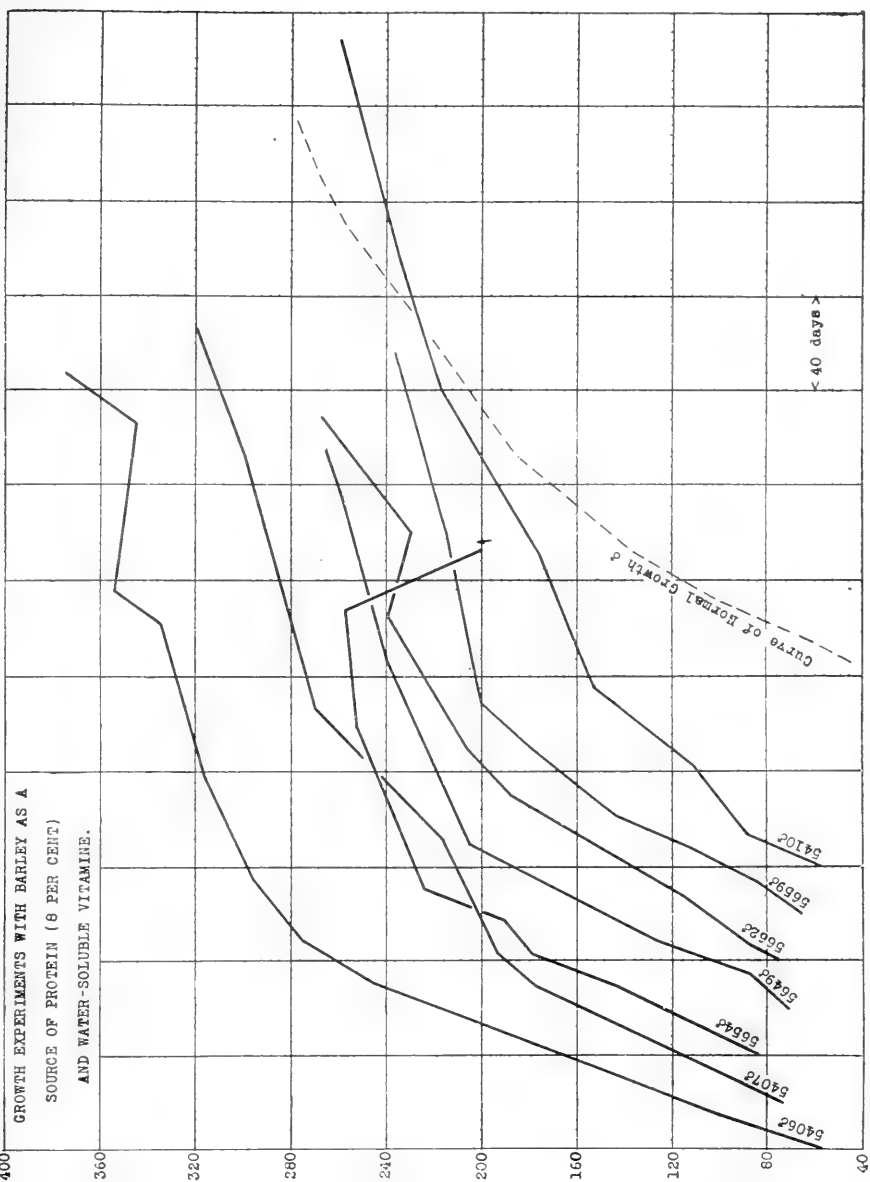

CHART II. Showing the growth of rats on an otherwise adequate diet in which all the protein (8 per cent) and the water-soluble vitamin were furnished by barley, which formed 72 to 75.5 per cent of the food mixture.

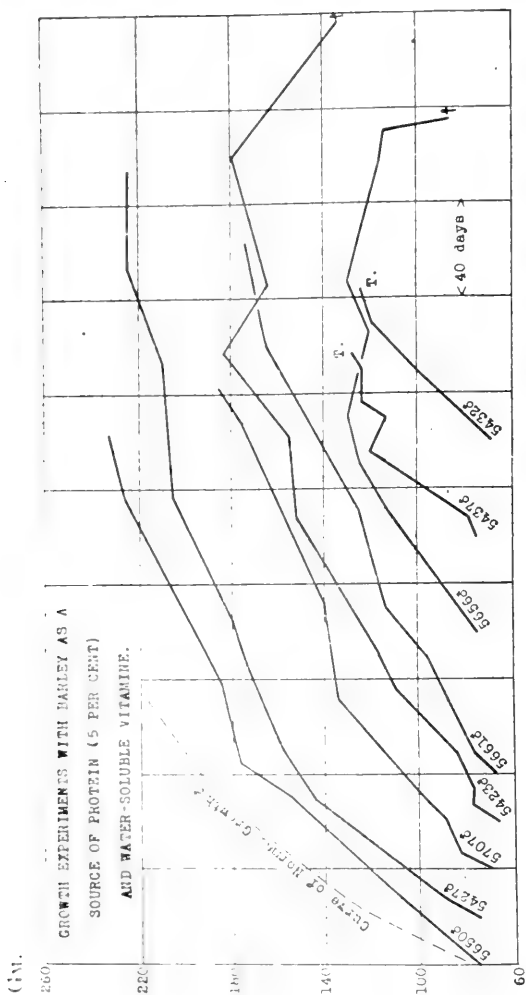

CHART III. Showing the growth of rats on an otherwise adequate diet in which all the protein (5 per cent) and the water-soluble vitamins were furnished by barley, which formed 45 to 47 per cent of the food mixture. Some of the experiments were terminated (T.) early without reference to the final outcome of the tests.

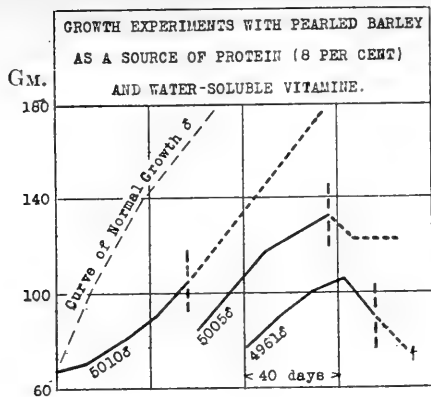

CHART IV. Showing the inferior growth of animals on an otherwise adequate diet in which all the protein (8 per cent) and the water-soluble vitamine were furnished by pearled barley, which formed 92 per cent of the food mixture. These results should be contrasted with the curves in Chart II. The failure to grow more vigorously was apparently not due to a lack of water-soluble vitamine in the preparation, since the addition of 0.2 gm. of dried brewery yeast during the period indicated by the interrupted line failed to promote any noteworthy increase in the rate of growth. This quantity of yeast has been demonstrated in repeated comparable experiments to furnish sufficient water-soluble vitamine for growth at a normal rate.

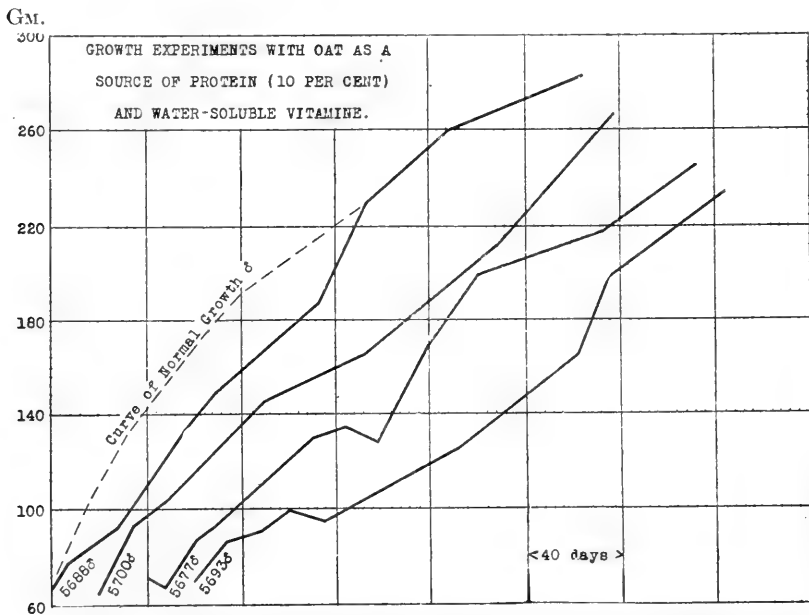

CHART V. Showing the growth of rats on an otherwise adequate diet in which all the protein (10 per cent) and the water-soluble vitamine were furnished by oat kernel, which formed 70 per cent of the food mixture.

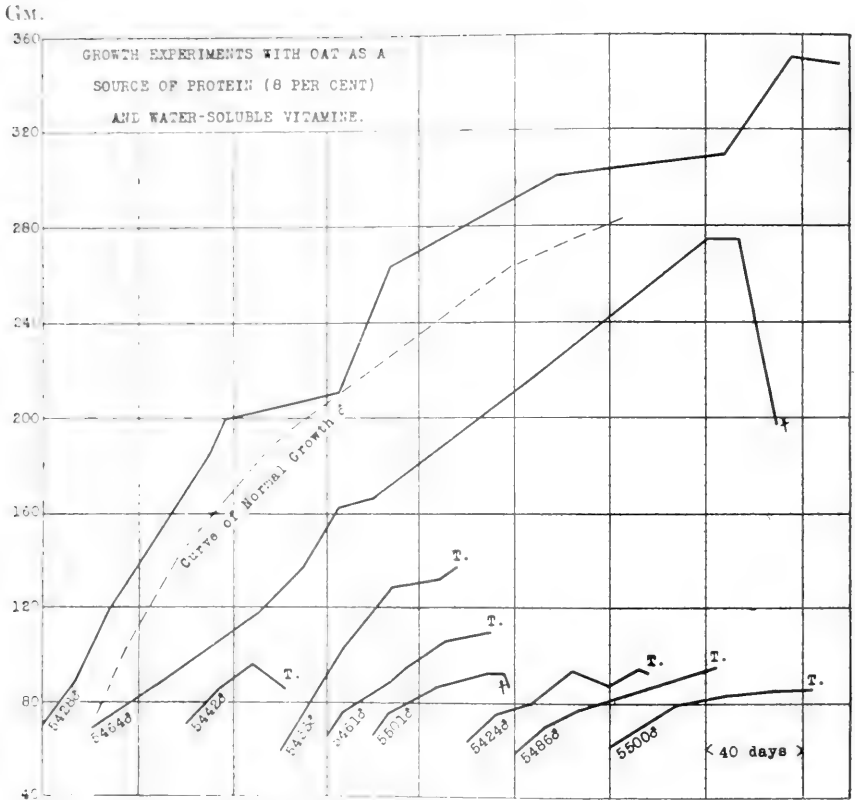

CHART VI. Showing the growth of rats on an otherwise adequate diet in which all the protein (8 per cent) and the water-soluble vitamine were furnished by oat kernel, which formed 57 per cent of the food mixture. Some of the experiments were terminated (T.) early without reference to the final outcome of the tests.

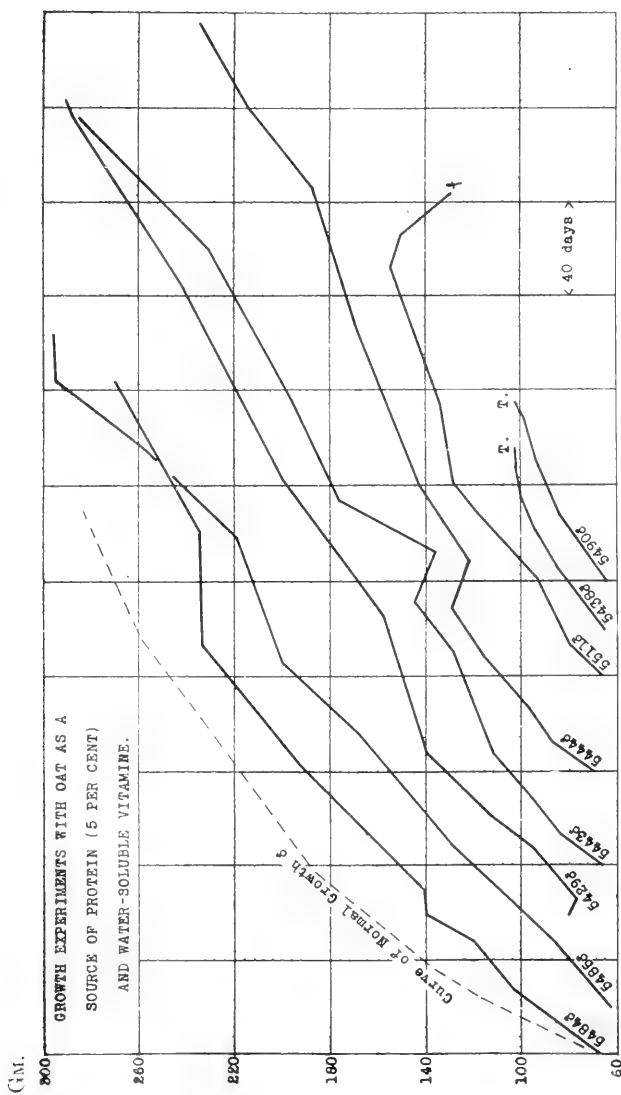

CHART VII. Showing the growth of rats on an otherwise adequate diet in which all the protein (5 per cent) and the water-soluble vitamin were furnished by the oat kernel, which formed 35.5 per cent of the food mixture. Some of the experiments were terminated (T.) early without reference to the final outcome of the tests.

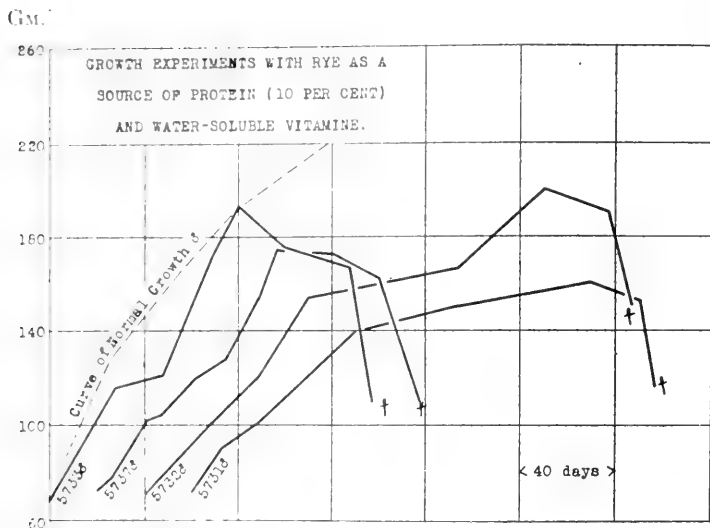

CHART VIII. Showing the growth of rats on an otherwise adequate diet in which all the protein (10 per cent) and the water-soluble vitamins were furnished by whole rye, which formed 80 to 85.4 per cent of the food mixture. The high mortality in the experiment is referred to in the text.

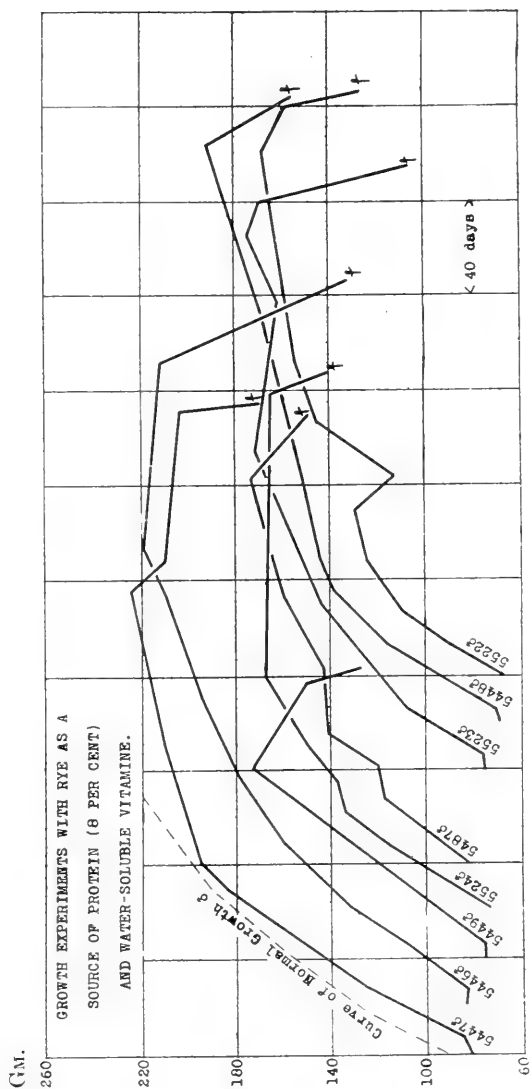

CHART IX. Showing the growth of rats on an otherwise adequate diet in which all the protein (8 per cent) and the water-soluble vitamins were furnished by whole rye, which formed 64 to 69.5 per cent of the food mixture. The high mortality in the experiment is referred to in the text.

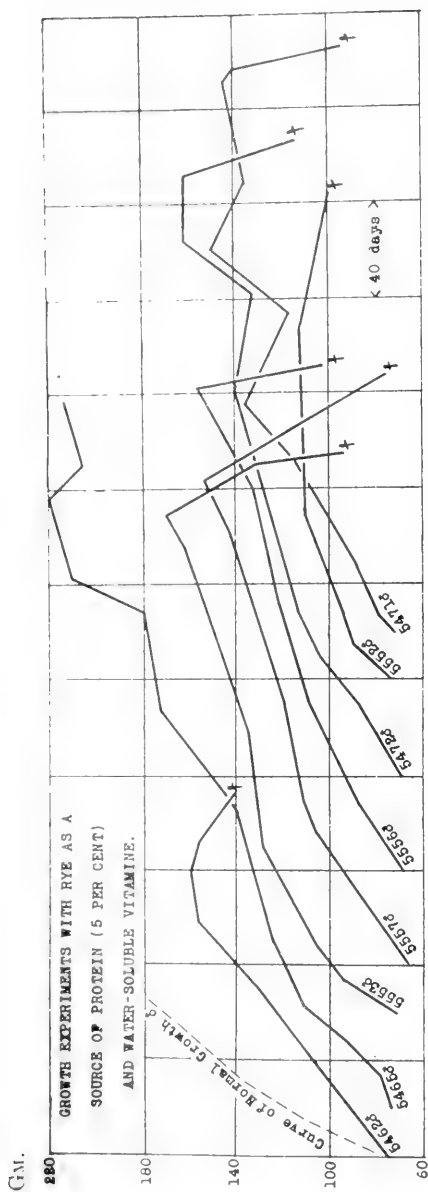

CHART X. Showing the growth of rats on an otherwise adequate diet in which all the protein (5 per cent) and the water-soluble vitamin were furnished by whole rye, which formed 40 to 42.7 per cent of the food mixture. The high mortality in the experiment is referred to in the text.

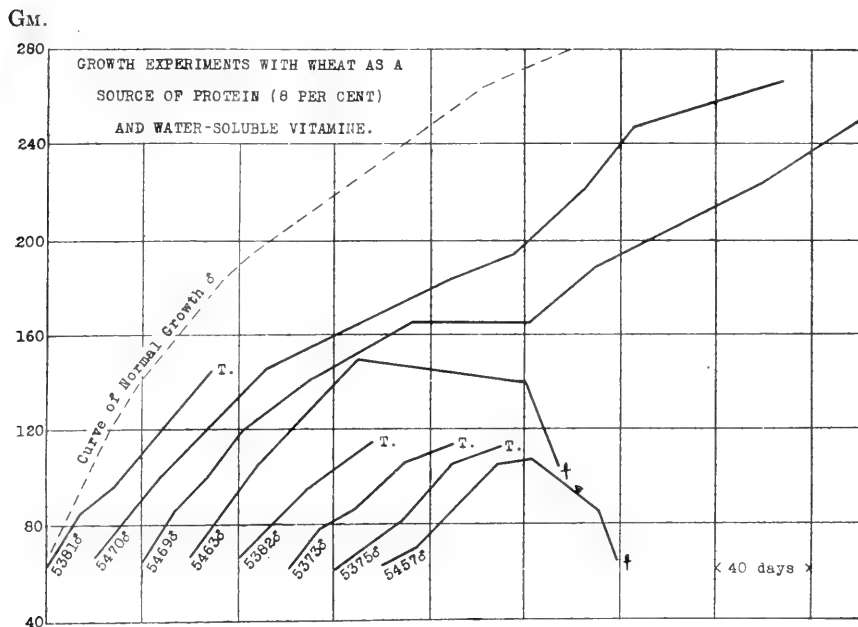

CHART XI. Showing the growth of rats on an otherwise adequate diet in which all the protein (8 per cent) and the water-soluble vitamins were furnished by whole wheat, which formed 70 per cent of the food mixture. Some of the experiments were terminated (T.) early without reference to the final outcome of the tests. The normal growth and reproduction of rats on a diet in which the protein and water-soluble vitamins are furnished by whole wheat are indicated by Osborne, T. B., and Mendel, L. B., *J. Biol. Chem.*, 1919, xxxvii, 557, Chart II.

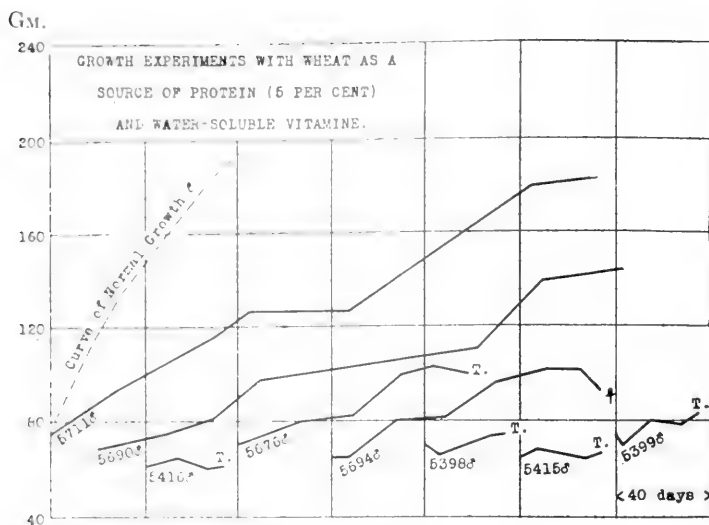

CHART XII. Showing the growth of rats on an otherwise adequate diet in which all the protein (5 per cent) and the water-soluble vitamine were furnished by whole wheat, which formed 51 per cent of the food mixture. Some of the experiments were terminated (T.) early without reference to the final outcome of the tests.

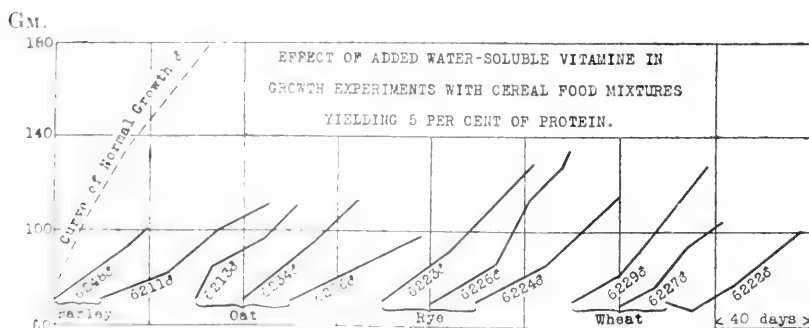

CHART XIII. Showing the effect of daily additions of a protein-free preparation of water-soluble vitamine from yeast, fed apart from the food mixture, which contained 5 per cent of protein furnished by barley, oat, rye, or wheat. The results should be contrasted with those from the comparable experiments on Charts III, VII, X, and XII respectively. They indicate that the failure to grow better on diets containing the smaller proportions of grains, equivalent to only 5 per cent of cereal protein, was not due to the lack of water-soluble vitamine in these instances. The vitamine preparation used is described by Osborne, T. B., and Wakeman, A. J., *J. Biol. Chem.*, 1919, xl, 383.

EFFECT OF THE CHLORINE SUBSTITUTION PRODUCTS OF METHANE, ACETALDEHYDE, AND OF SODIUM ACETATE ON CATALASE PRODUCTION.*

BY W. E. BURGE AND E. L. BURGE.

(From the *Physiological Laboratory, University of Illinois, Urbana.*)

(Received for publication, January 13, 1920.)

It is recognized that the introduction of chlorine into the molecule of an aliphatic narcotic greatly enhances its effect as a narcotic. Snow (1), Bert (2), Arloing (3), Verworn (4), and others have shown that, as a rule, oxidation is decreased during anesthesia and hence the conclusion has been drawn that narcosis may be due to the inhibition or interference with oxidation, while Crile (5) claims that it is due to the acidosis arising from diminished or defective oxidation. We (6) found that narcotics decrease catalase, an enzyme possessing the property of liberating oxygen from hydrogen peroxide, by diminishing its output from the liver and by direct destruction of the enzyme, and hence concluded that the diminished oxidation during narcosis may be due to the decrease in catalase. It was also found that glycocoll, in keeping with Lusk's observation (7) that this amino-acid increased oxidation in the body, produced a very great increase in catalase. Acetic acid or its sodium salt, a substance closely related chemically to glycocoll, was also found to produce a great increase in catalase by stimulating the alimentary glands, particularly the liver, to an increased output of this enzyme.

The present investigation was begun in an attempt to determine whether the introduction of increasing amounts of chlorine into the methane molecule would increase its destructive effect on catalase, and whether the introduction of increasing amounts

* An abstract of this paper was read at the annual meeting of the Federation of American Societies for Experimental Biology, Cincinnati, December, 1919.

of chlorine into the acetic acid molecule would diminish its effectiveness in producing an increase in catalase. The animals used were dogs, rabbits, and cats. The substances used were methane (CH_4), monochloromethane (CH_3Cl), dichloromethane (CH_2Cl_2), trichloromethane (chloroform, CHCl_3), tetrachloromethane (CCl_4); acetaldehyde (CH_3CHO), chloral (CCl_3CHO); sodium monochloroacetate ($\text{CH}_2\text{ClCOONa}$), sodium dichloroacetate ($\text{CHCl}_2\text{COONa}$), and sodium trichloroacetate (CCl_3COONa). The amounts of the substances will be given in the description of the experiments. The catalase was determined by adding 0.5 cc. of blood to diluted hydrogen peroxide at approximately 22°C . in a bottle, and the amount of oxygen gas liberated in 10 minutes was taken as a measure of the amount of catalase in the 0.5 cc. of blood. Account was taken in these experiments and corrections were made for the inhibiting action of acids and acid salts on catalase as observed by Jacobson (8), Loevenhart and Kastle (9), Issajew (10), Senter (11), Winternitz and Rogers (12), Mendel and Leavenworth (13), and Bodansky (14), as well as the effect of alkalis and alkaline salts.

In Fig. 1 are shown the effects of methane, acetaldehyde, and sodium acetate together with that of their chlorine substitution products on the blood catalase *in vivo* as well as *in vitro*. The figures along the abscissæ indicate time in minutes and the figures along the ordinate, percentage increase or decrease in catalase. The trichloromethane or chloroform, and tetrachloromethane were administered by bubbling air through these substances in a bottle which was connected by a rubber tube to a cone adjusted over the snout of the animal, while the methane, mono- and dichloromethane were led directly from the generator into an inverted glass vessel containing the animal. The animals used were rabbits. The catalase in 0.5 cc. of blood from the jugular vein was determined before as well as at intervals after the administration of the substances. In the chart it may be seen that methane (CH_4) had little or no effect on the blood catalase; monochloromethane (CH_3Cl) decreased it 22 per cent in 45 minutes; trichloromethane (chloroform, CHCl_3), 32 per cent; and tetrachloromethane (CCl_4), 37 per cent. From these figures it may be seen that the more chlorine there is in the methane molecule, the more effective it becomes in decreasing the blood catalase.

It may be seen further in the chart that glycocoll ($\text{CH}_2\text{NH}_2\text{-COOH}$) increased the blood catalase 52 per cent in 60 minutes; sodium acetate (CH_3COONa), 42 per cent; sodium monochloroacetate ($\text{CH}_2\text{ClCOONa}$), 37 per cent; sodium dichloroacetate ($\text{CHCl}_2\text{-COONa}$), 23 per cent; and sodium trichloroacetate (CCl_3COONa) produced practically no change in the blood catalase. Cats were used in these experiments. The amounts of the substances used were 10 gm. per kilo dissolved in 75 cc. of water. The substances were introduced into the upper part of the small intestine and the blood from the jugular vein was used for the catalase determinations. It may also be seen that 0.6 gm. per kilo of acetaldehyde (CH_3CHO) decreased the catalase 12 per cent, and that a similar amount per kilo of its chlorine substitution product, chloral (CCl_3CHO), decreased the catalase 22 per cent in 90 minutes. The animals used in these experiments were rabbits and the substances, dissolved in 50 cc. of water were introduced by means of a stomach tube.

The second part of this paper is concerned with determining the mode of action of the chlorine substitution products of methane and acetaldehyde in producing a decrease and of sodium acetate in producing an increase in catalase and also in finding an explanation for the fact that the introduction of chlorine into the acetic acid molecule diminishes its effectiveness in increasing catalase. In Fig. 1 under "*in vitro*" are shown the effects on the catalase of cat's blood when exposed to methane and its chlorine substitution products. The amount of defibrinated blood used was 5 cc., which was poured into a glass vessel in which it formed a layer about 2 mm. thick. Such preparations were exposed to methane and to its chlorine substitution products at 40°C . for the times indicated in the chart. It may be seen that the exposure of the blood to methane had practically no effect on its catalase; the exposure to monochloromethane gas decreased the catalase very little in 60 minutes; the exposure to dichloromethane decreased it 21 per cent in 15 minutes and 62 per cent in 45 minutes; the exposure to trichloromethane gas decreased it 48 per cent in 15 minutes and 76 per cent in 45 minutes. From these figures it is clear that increasing the amount of chlorine in methane increased its destructive effect on catalase *in vitro*. It may be seen further in the chart that neither sodium acetate nor any of its chlorine sub-

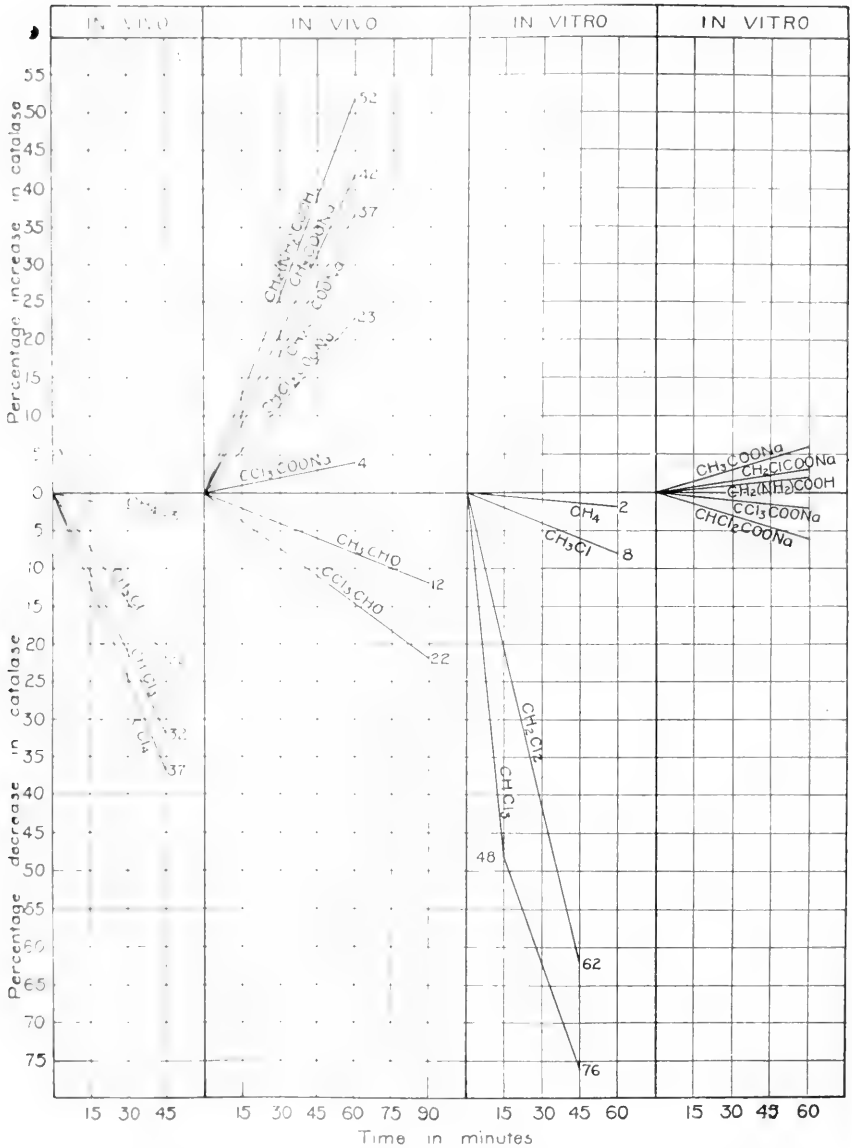

FIG. 1. Curves showing effect of the substances named in the chart on the catalase content of the blood.

stitution products had any effect on catalase *in vitro*. 100 mg. of each of these substances were added to 5 cc. of defibrinated cat's blood and the catalase determinations, using neutral hydrogen peroxide, were made at the intervals indicated in the chart.

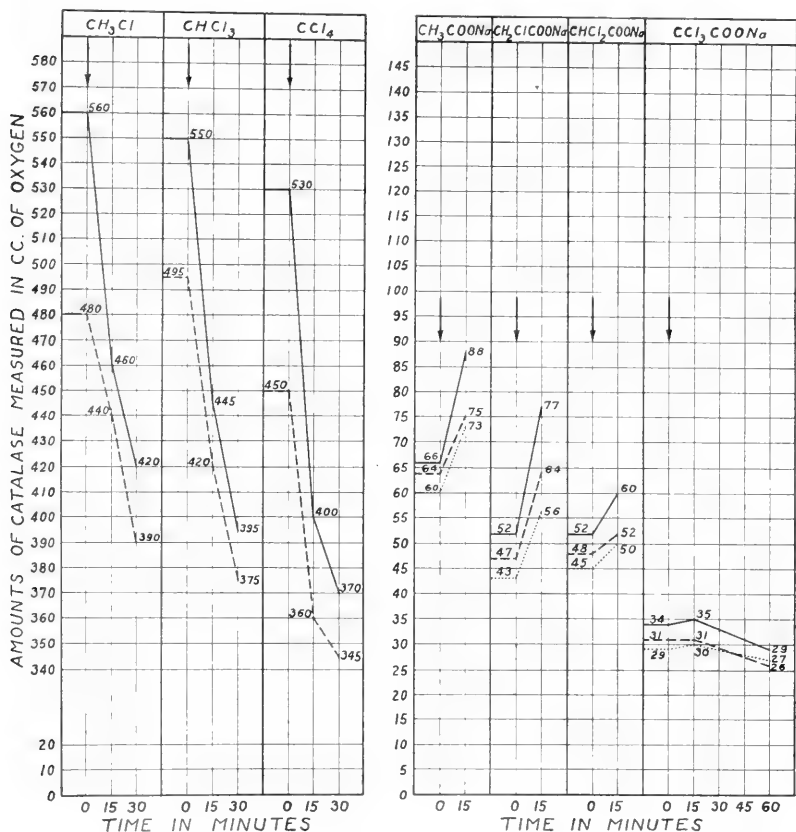

Fig. 2. Curves showing effect of the substances named in the chart on the catalase content of the blood. The continuous line curves show amount of catalase in the blood of the liver, the dash line curves the amount in the blood of the portal vein, and the dotted line curves the amount in the blood of the jugular vein.

In Fig. 2 are shown the effects of the administration of the chlorine substitution products of methane and of sodium acetate on the catalase of the blood of the liver, portal, and jugular veins.

The continuous line curves were constructed from data obtained from the blood of the liver, the dash line curves from the blood of the portal, and the dotted line curves from the blood of the jugular vein. The chloroform and tetrachloromethane were administered by bubbling air through these substances in a bottle which was connected by a rubber tube to a cone adjusted over the snout of the animal while the monochloromethane was led directly from the generator to the animal. These substances were administered in as concentrated form and in as large amounts as could be done and at the same time keep the animal alive. The animals used for the study of these chlorine substitution products were cats. It may be seen under monochloromethane (CH_3Cl) that previous to the use of this material 0.5 cc. of blood from the liver liberated 560 cc. of oxygen from hydrogen peroxide in 10 minutes and that 0.5 cc. of blood from the portal vein of the same animal liberated 480 cc.; after 15 minutes use of the monochloromethane the blood of the liver liberated 460 cc. of oxygen and that of the portal vein 440 cc. and after 30 minutes the blood of the liver liberated 420 cc. of oxygen and that of the portal vein 390 cc. Under trichloromethane (CHCl_3) and tetrachloromethane (CCl_4) it may be seen that these substances also produced a decrease in the catalase of the blood of the liver and of the jugular vein. By comparing these figures it is evident that the catalase content of the blood of the liver in all the animals used was much greater than that of the blood of the portal vein. This is taken to mean that the liver is putting out catalase continuously into the blood. By comparing the decreases produced by these substances in the catalase of the blood of the liver and of the portal vein it may be seen that they produced a much greater decrease in the blood of the liver than they did in the blood of the portal vein. This is taken to mean that these substances were decreasing the output of catalase from the liver. It should be mentioned in this connection that Becht (15) has repeated some of our work on the effect of narcotics on the blood catalase and claims that catalase is increased instead of being decreased during narcosis.

In Fig. 2 are shown also the effects of sodium acetate and its chlorine substitution products on the catalase of the blood of the liver, portal, and jugular veins. The animals used were dogs. After opening the abdominal wall of these animals with the use

of ether anesthesia, 10 gm. per kilo in 300 cc. of water were introduced into the upper part of the small intestine. By comparing these figures it may be seen that sodium acetate produced an increase in the catalase of the blood and that this increase was greater in the blood of the liver than it was in the blood of the portal and jugular veins. This suggests that the sodium acetate was stimulating the liver to an increased output of catalase. Similarly it may be seen that the mono- and dichlorine substitution products of sodium acetate produced an increase in catalase in 15 minutes while the trichlorine substitution product produced a small decrease in 60 minutes. By comparing these figures it may be seen that the effect of the introduction of chlorine into the sodium acetate molecule was to decrease its effectiveness in stimulating the liver to an increased output of catalase.

SUMMARY.

1. The more chlorine that is introduced into the methane molecule the more effective it becomes in decreasing catalase. Similarly, the strong narcotic chloral, a trichlorine substitution product of acetaldehyde, decreases catalase more than does acetaldehyde, a weaker narcotic. The ingestion of sodium acetate produces an increase in catalase. The introduction of increasing amounts of chlorine into the sodium acetate molecule renders it less effective in increasing catalase.

2. The chlorine substitution products of methane decrease catalase by direct destruction of the enzyme and by decreasing its output from the liver. Sodium acetate produces an increase in catalase by stimulating the liver to an increased output. The introduction of chlorine into the molecule renders it less effective as a stimulant on catalase production.

3. The increase in oxidation following the ingestion of glycocholl or a closely related compound, acetic acid (sodium salt), is attributed to the increase in catalase. The decrease in oxidation arising during chloroform and chloral anesthesia and assumed by some to be the cause of the narcosis is attributed to the decrease in catalase.

BIBLIOGRAPHY.

1. Snow, J., Experimental papers on narcotic vapours, 1848; Chloroform and other anaesthetics, 1858.
2. Bert, P., in Dastre, Les anaesthesiques, Paris, 1890.
3. Arloing, in Dastre, Les anaesthesiques, Paris, 1890.
4. Verworn, M., Narkose, Jena, 1912; *The Harvey Lectures*, 1911-12, 52.
5. Crile, G. W., The origin and nature of the emotions, Philadelphia and London, 1915.
6. Burge, W. E., *Am. J. Surg.*, 1919, lxxxiii, 18.
7. Lusk, G., *J. Biol. Chem.*, 1912-13, xiii, 155.
8. Jacobson, J., *Z. physiol. Chem.*, 1892, xvi, 340.
9. Loevenhart, A. S., and Kastle, J. H., *Am. Chem. J.*, 1903, xxix, 397.
10. Issajew, W., *Z. physiol. Chem.*, 1905, xlv, 331; xlv, 546.
11. Senter, G., *Z. physik. Chem.*, 1903, xlv, 257.
12. Winternitz, M. C., and Rogers, W. B., *J. Exp. Med.*, 1910, xii, 755.
13. Mendel, L. B., and Leavenworth, C. S., *Am. J. Physiol.*, 1908, xxi, 85.
14. Bodansky, M., *J. Biol. Chem.*, 1919, xl, 127.
15. Becht, F. C., *Am. J. Physiol.*, 1919, xlvi, 171.

AN IMPROVED VOLUMETRIC PUMP FOR CONTINUOUS INTRAVENOUS INJECTIONS.

By R. T. WOODYATT.

(From the Otho S. A. Sprague Memorial Institute, Laboratory for Clinical
Research, Rush Medical College, Chicago.)

Plate 3.

(Received for publication, January 16, 1920.)

A machine described earlier¹ consisted essentially of a single glass syringe fitted with a two-way valve, syringe and valve being operated by an electric motor acting through a worm gear, eccentrics, and rods. The discharge of the pump was controlled coarsely by setting the stroke of the piston by means of a system of levers and more exactly through control of the motor speed by means of a rheostat. This system involved the use of variable speed motors and changing motor speeds, with the inherent disadvantages which this implies from the standpoint of uniform performance.

The present machine mounts two glass syringes or cylinders each fitted with a two-way valve. Both pumps are run by one motor acting as before through a worm gear, eccentrics, etc. The former method of adjusting the stroke is displaced by a new device which is applied separately to each piston rod. The new device is simpler and much more accurate than the old and permits the stroke of either piston to be set independently in a few seconds at the desired length while the machine is running or stopped. Owing to the stroke adjustment it becomes unnecessary to alter the speed of the motor during an experiment, thus making it possible to drop the variable speed motor and rheostat in favor of a motor of constant speed type with the decided advantage that the operator's attention is not required to secure uniform performances. With a half-horse-power "Synchronous" motor, long experiments involving repeated changes in the rate of dis-

¹ Woodyatt, R. T., *J. Biol. Chem.*, 1917, xxix, 355.

charge from one or both cylinders have been conducted easily and with negligible fluctuations of the motor speed.

The stroke adjustment is illustrated in Text-fig. 1. The motion of the motor is transmitted through a worm gear to the eccentric E and by the eccentric rod to a carriage plate C. The carriage C moves in a grooved bed plate in the direction of the arrows making a stroke equal to the stroke X of the eccentric. The diagram shows the piston rod P broken off at its point of emergence from the pump cylinder. The piston rod is jointed for convenience in taking the machine apart and terminates in a hard steel head H standing free in the space SS'. This space is the measuring gap in a machinist's micrometer modified for the purpose. The micrometer is fixed by a mounting on the right to the carriage itself and projects to the left over the plane of the carriage with clearance to permit of its operation. The distance SS' can be given any value desired by loosening the lock nut L and turning the milled collar M which causes the surface S to move toward or away from S'. When the machine is in motion it will be seen that the distance SS' can be made so great that after one complete stroke the head H will have been pushed as far to the left as the extreme forward motion of S' will permit, after which it will remain stationary, S' just touching it at the end of each subsequent forward stroke while on the back stroke S will merely approach H. But as the gap SS' is shortened by turning M so that S approaches S' a position may be found in which at the end of the back stroke S will also just touch H. With this setting of the micrometer, H is just touched but not moved on the forward stroke by S' and on the back stroke by S. This position corresponds to 0 on the scale and collar of the micrometer. The carriage now moves back and forth through the distance X while none of its motion is imparted to the piston although while the piston remains stationary the valves are turned. Now if S is set 1 cm. closer to S' as read directly on the scale and collar, then H will be displaced 1 cm. on the back stroke and on the forward stroke will return to its former position, and so on for any setting within the range of the apparatus. The micrometer reads to 0.04 mm.

It will be noted that with this device the head H and so the piston rod and piston are free during the interval after the surface

S' having pushed H to the limit is receding and while the surface S is approaching H but is not yet in contact with it. This interval follows immediately upon the completion of the systole of the pump when the pressure of the fluid in the discharge tube leading from the pump is highest. If sufficient back pressure develops it may kick back the piston before the valve cuts off the communication thus destroying the quantitative character of the pump and reducing the total discharge. There is a similar interval at the end of the diastole during which the pressure of the gravity feed

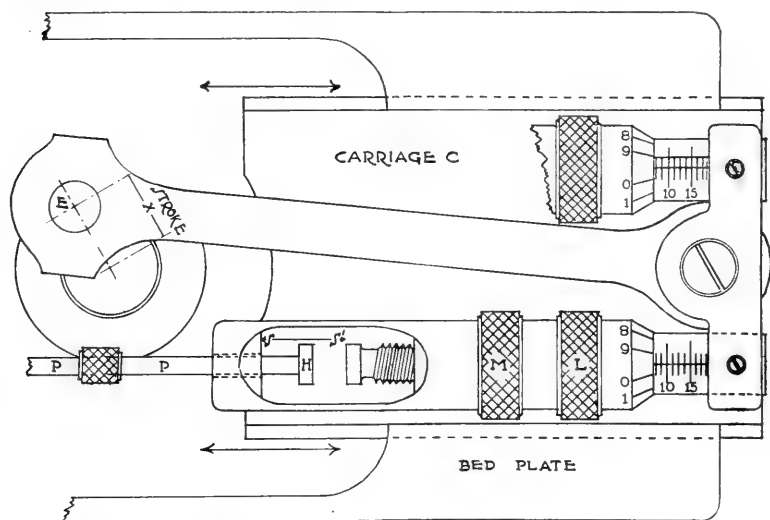

TEXT-FIG. 1. Improved volumetric pump for continuous intravenous injections. The actual length is 10 inches over all.

if such is used might move a loose piston and allow the cylinder to take in more than the indicated volume of fluid at each stroke. These sources of error are eliminated by a friction check on the piston rod which makes it impossible for the piston to move except in response to impacts of the surface S and S'.

The present machine has the advantages of two single machines of the earlier type in that it permits the simultaneous injection of one or two liquids into one or two discharge tubes, both constantly at different rates bearing known ratios, one constantly

at one rate with one varying, or both varying as desired. The accuracy and evenness of performance as well as the convenience of operation are much higher than in the older machine. Having a motor which runs always at the same speed, a cylinder (syringe) is calibrated by direct observation of the total volume which it discharges during periods of 15 minutes to 1 hour, with the stroke set at 0, at 15 mm., and at two or more intermediate points. In plotting the results they are found to fall on a straight line and the chart so formed indicates the setting of the micrometer necessary for the delivery of any desired volume per hour. When set to deliver a given volume in an hour, the results with the present motor fed from an ordinary power circuit have frequently fallen within 0.1 to 0.3 cc. of the desired total.

The machine was made by William Gaertner and Company, 5345 Lake Park Avenue, Chicago, Illinois, and is illustrated in Fig. 1.

EXPLANATION OF PLATE 3.

FIG. 1. Assembled machine. The syringes and valves are demountable without tools for cleansing and sterilization purposes. The large screw head at the left and below is at the end of the worm shaft bearing. The motor shaft is coupled to the opposite end of the worm shaft.

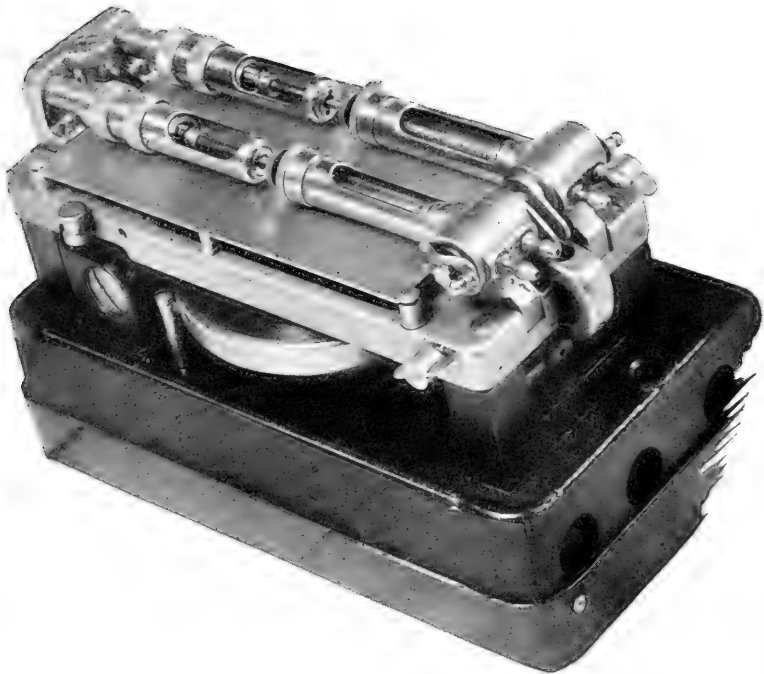

FIG. 1.

(Woodyatt: Pump for intravenous injections.)



BIOCHEMISTRY OF THE ACETONE AND BUTYL ALCOHOL FERMENTATION OF STARCH BY *BACILLUS GRANULOBACTER PECTINOVORUM*.

By HORACE B. SPEAKMAN.

(From the Department of Zymology, Toronto University, Toronto.)

(Received for publication, January 10, 1920.)

During the last 4 years a considerable amount of research, chiefly along industrial lines, has been performed in connection with the production of acetone together with various alcohols by the fermentation of carbohydrate media, using cultures of different bacteria. Some of this work has already been described in the literature (1, 2). Contributions have also been made to our knowledge of the biochemistry of these important processes. Northrop and his collaborators (3) have studied in detail the behavior of *Bacillus acetoethylicum* in standard media, and also the influence of certain factors, namely the reaction of the media, the size of the inoculation, the supply of air and nitrogen (peptone), and the temperature of the medium, on the growth of the organism and the yields of acetone and ethyl alcohol. They record that the principal acid produced during the fermentation is formic. At a conference held in London during the past year the position regarding the production of acetone with butyl alcohol by fermentation methods was discussed (4). More recently Fred and his collaborators (5) have shown that during the fermentation of xylose a mixture of acetic and lactic acids is produced, using cultures of bacteria isolated from manure, silage, etc.

An effort has been made during this investigation to identify and study the rôle of the intermediate compounds formed during the fermentation of starch by *Bacillus granulobacter pectinovorum*.¹

¹ The culture used in the research has been developed from tubes received from Dr. C. Weizman in 1915 when it was my privilege to be associated with him in the early stages of the more general investigation.

Products of the Fermentation.

At the meeting in London the percentage yields of acetone and butyl alcohol were given as 7 and 14 per cent respectively of the weight of maize meal used. During the last 3 years very large volumes of these two compounds were prepared by this process in Toronto, and by an analysis of the data obtained we were able to calculate the various yields. The following is a summary of these calculations.

Weight of dry corn distilled.....	73,463,654 lbs.
Gross production of acetone.....	6,248,131 "
Net " " " "	5,741,273 "
Total " " alcohols.....	12,660,834 "
Gross yield of acetone on dry corn distilled.....	8.5 per cent.
Net " " " " " " " "	7.76 " "
Yield of alcohols on dry corn distilled.....	17.23 " "

These results indicate that as the culture and methods of working have improved the percentage yields have increased.

During the distillation it was discovered that ethyl alcohol occurs in the middle fractions. In addition to the large low and high boiling fractions, containing acetone and butyl alcohol respectively, a large fraction is obtained boiling between 85–91.5°C. The latter contains the three neutral products of the fermentation and water. By redistillation pure ethyl alcohol, boiling point 78°C., has been prepared from it. The chemical staff engaged in the work has estimated that the total weight of alcohol produced contains approximately 7.6 per cent of ethyl alcohol.

During the fermentation large volumes of carbon dioxide and hydrogen are produced. The sugar and organic acids formed during the fermentation have been isolated and identified. An attempt has also been made to show the part played by these compounds in the biochemical system underlying the production of the two alcohols and acetone.

Hydrolysis of Starch.

The medium used was in the form of a starch gel, with a heavier layer at the base composed of fiber and protein-containing tissue. Immediately after inoculation liquefaction of the starch com-

mences. By the usual methods it was found that with the liquefaction there is a rapid formation of a reducing sugar. If a small volume of the clear fluid is removed from the flask and added to a 1 per cent starch paste with a slight amount of toluene, it is found that after 24 hours the starch is completely hydrolyzed to a sugar which is a strong reducer of Fehling's solution and forms an osazone very rapidly. From these results and those from suitable controls it was concluded that an enzyme is secreted by the organism which acts upon the starch gel.

The osazone produced was isolated and purified. Only crystals having the characteristic form of glucosazone were to be seen in the specimens obtained from many experiments of this nature. The crystals were found to melt at 204.5°C.

Larger volumes of mash were then inoculated and at the end of 4 hours the flasks were removed from the incubator and an excess of toluene was added to the contents. These were dialyzed against distilled H₂O or Ringer's fluid for 6 days. A mixture of sugar and protein cleavage products passed through the membrane. The solution was evaporated to a small volume under reduced pressure and decolorized with animal charcoal. The residue was extracted with 95 per cent alcohol and reconcentrated. The 95 per cent alcohol solution was then allowed to evaporate at 35°C. A mass of needle-shaped crystals was obtained. The aqueous solution of these crystals was dextro-rotatory. From these facts we conclude that the first stage in the fermentation is the hydrolysis of starch to glucose. The nature and properties of the enzyme responsible for this conversion are being more fully investigated.

Acidity Changes.

To obtain information regarding the acidity changes in the fermenting mash, samples of the medium uniform in volume were titrated at regular intervals with 0.1 N NaOH. Curve A in Chart 1 expresses such changes in a normal fermentation. By means of these results the fermentation period can be divided into three sections: (a) the time during which the acidity is rising to a maximum, followed by (b) the time during which the acidity is falling, and (c) a third period during which the acidity rises very slowly from the minimum reached in (b).

322 Biochemistry of *B. granulobacter pectinovorum*

Curve B in the same chart shows the rate of gas production of this fermentation, based on hourly readings of the rate. We find that during the first of the three phases of the fermentation period the rate rises steadily. When the acidity of the mash is approaching and at the maximum, the rate of gas production falls

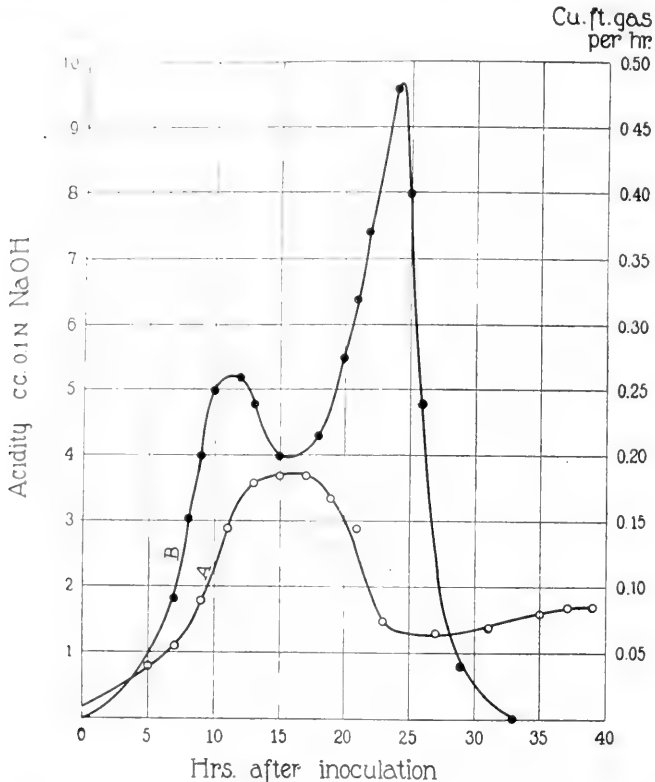

CHART 1. Curve A represents the acidity of 10 cc. samples in terms of 0.1 N NaOH; Curve B the gas produced per hour during the fermentation.

temporarily, and during the second phase rises once more very rapidly to a maximum. Towards the close of the fermentation the rate falls sharply to zero.

The acidity changes and gas production have been studied in two types of abnormal fermentations. For reasons which are

often difficult to define, the life cycle period of the bacillus is sometimes much prolonged. The fermentation is sluggish and the yields are poor. In addition to the morphological features of the organism, such a fermentation has characteristic acidity and gas rate curves. In Chart 2 examples are shown. Curves A and B represent the acidity and rate of gas production readings of a

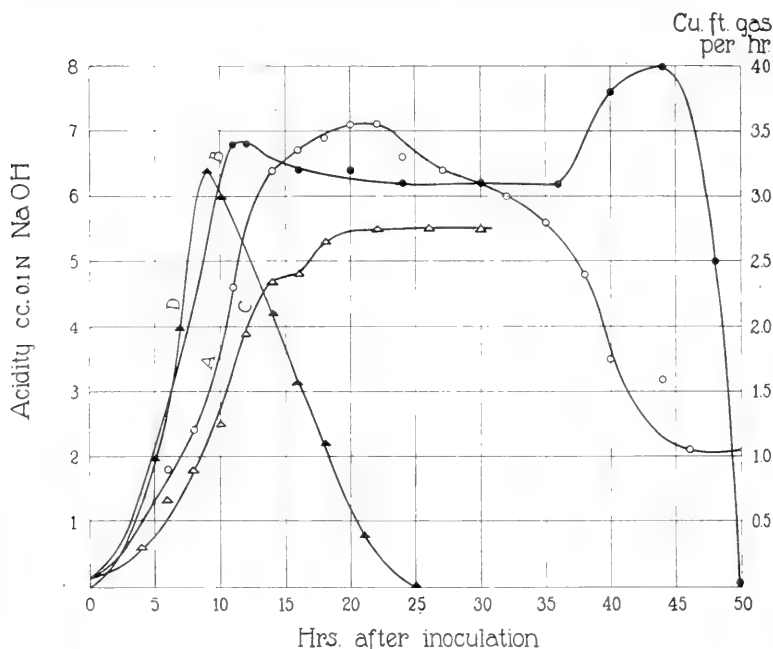

CHART 2. Curve A is the acidity curve and Curve B the gas curve of a slow fermentation. Curves C and D are the corresponding curves for a fermentation conducted at 110° F.

fermentation, volume 20,000 gallons, which was inoculated on September 28, 1917.

With the abnormal prolongation of the maximum acidity period, there is a long delay in the occurrence of the rapid rise in the rate of gas production, and when this increase does develop the maximum rate is very much below the normal.

In the same chart Curves C and D relate to an experiment in which the fermentation was conducted at 110° F. instead of 98° F.

324 Biochemistry of *B. granulobacter pectinovorum*

Experiment 1.—A mixture of 3.5 gallons of water and 2 pounds of meal was made in a copper culture vessel. The vessel was maintained at 7 to 8 pounds steam pressure for 3 hours, and the contents were then cooled to the temperature required. To the mash 300 cc. of an active culture were then added. The acidity was determined at regular intervals and the gas produced measured on a small experimental gas-meter. The results obtained are presented in Table I.

TABLE I.

Date.	Time after inoculation.	Gas per hr.	0.1 N NaOH required for 10 cc. sample.
1917	hrs.	cu. ft.	cc.
Nov. 30, 2.00 p.m.			
6.00 "	4	0.140	0.9
8.00 "	6	0.290	
12.00 m.	10	0.445	2.4
Dec. 1, 2.00 a.m.	12	0.379	3.9
4.00 "	14	0.320	4.6
6.00 "	16	0.244	5.1
8.00 "	18	0.161	5.1
12.00 n.	22	0.026	5.0
2.00 p.m.	24	0.012	5.5
4.00 "	26	0.007	5.4
6.00 "	28	0.004	5.6
8.00 "	30	0.002	5.4
10.00 "	32		5.4

We find that working under the conditions mentioned, it is possible to obtain the following results: (a) the rate of gas production does not rise after the preliminary fall which has already been observed in the normal, but continues to fall to 0 and (b) the acidity does not fall from the normal maximum, but after a slight pause a second increase occurs, and finally an abnormal and constant maximum is reached.

These examples of three different types of fermentation indicate that in the biochemical system there is a close association between the activity of the living cell, expressed by the evolution of gas, and the changes in the acidity of the medium. We may conclude that the fall in acidity during the second phase of the fermentation period is dependent upon organized cell life processes and is not the result of free enzyme activity.

Influence of Starch Concentration on the Acidity Changes of the Medium.

The following are examples of a series of experiments which was carried out to determine in what way the acidity of the fermenting mash was influenced by increasing the concentration of solids. The concentrations used were within the range in which the rate of fermentation is proportional to the concentration of starch in the medium.

Experiment 2.—Three flasks containing maize mash of the concentrations 3, 5, and 7 per cent were sterilized in the autoclave for 2.5 hours at 10 pounds steam pressure. They were inoculated with test-tube cultures of the bacillus in 5 per cent mash. The acidity of the flasks was determined at regular intervals, and the results from the experiment are given in Table II.

TABLE II.

Meal.	Acidity after inoculation. 0.1 N NaOH required for 10 cc. sample.						
	14.5 hrs.	16.5 hrs.	19.5 hrs.	21.5 hrs.	26.5 hrs.	38.5 hrs.	43.5 hrs.
<i>per cent</i>	<i>cc.</i>	<i>cc.</i>	<i>cc.</i>	<i>cc.</i>	<i>cc.</i>	<i>cc.</i>	<i>cc.</i>
3	3.20	3.90	4.20	4.10	2.60	2.20	2.00
5	3.95	4.95	5.80	5.90	5.00	1.90	2.30
7	4.00	5.60	6.60	6.60	5.70	1.95	2.30

Experiment 3.—The last experiment was repeated with the exception that the flasks fermented contained 2, 4, 6, and 8 per cent mash respectively. In connection with these experiments it is necessary to emphasize the importance of a correct choice of culture with which to inoculate the flasks. It must all be derived from the same spore stock, and the tubes, containing equal volumes, must all be of the same generation and the same age. The results from this experiment are given in Table III.

TABLE III.

Meal.	Acidity after inoculation. 0.1 N NaOH required for 10 cc. sample.							
	7 hrs.	12 hrs.	15 hrs.	20 hrs.	24 hrs.	34 hrs.	40.5 hrs.	60 hrs.
<i>per cent</i>	<i>cc.</i>	<i>cc.</i>	<i>cc.</i>	<i>cc.</i>	<i>cc.</i>	<i>cc.</i>	<i>cc.</i>	<i>cc.</i>
2	0.9	1.8	2.2	2.8	2.7	1.8	1.8	2.0
4	1.2	2.7	3.5	4.2	3.6	2.0	2.0	
6	1.5	3.3	4.5	4.8	4.5	3.1	1.8	
8	1.9	3.6	5.0	5.3	4.9	2.6	1.9	

These results indicate that the acidity of the mash during the fermentation is controlled at least in part by the concentration of meal used. We find that in each series of flasks the acidity increased with the concentration. The two series of flasks when grouped together do not form a regular sequence as regards both the concentration of the mash and the acidity readings. For example, the 3 per cent flask of the first set does not occupy a position between the 2 and 4 per cent flasks of the second set. This condition of things has been confirmed during a much wider study of fermentations of various concentrations. It is clear that the influence of the concentration of starch in the medium on the acidity must be regarded as one only of several factors affecting the latter.

Influence of the Rate of Fermentation on the Maximum Acidity.

Until the biochemistry of the fermentation is more completely analyzed and understood we can only group together a number of these unknown factors and express the sum of their influences in general terms, such as the time occupied by the fermentation of a known weight of meal, or the yields of the various products under certain conditions. In the production of acetone on a large scale, when the time factor was of great importance, we expected those fermentations which had a maximum acidity higher than the average to occupy a longer time period; those with a lower maximum to be correspondingly quicker. To verify such a hypothesis the accumulated observations of a large number of carefully controlled experiments will be required. At present there are available the laboratory records of several thousands of fermentations, showing the volume and concentration of the medium, the time occupied by, the gas produced by, and the acidity changes of the fermentation. They were obtained originally for practical purposes, but although not free from errors they may assist in the consideration of this problem. One of my colleagues has taken from the records several hundreds of complete sets of observations relating to large fermentations of uniform volume and concentration. These have been arranged in groups according to the number of hours in the fermentation period. The number of examples in each and the average maximum acidity

TABLE IV.

Time of fermentation.	No. of examples.	Average maximum acidity.	Time of fermentation.	No. of examples.	Average maximum acidity.
<i>hrs.</i>		<i>cc.</i>	<i>hrs.</i>		<i>cc.</i>
24	9	5.1	35	35	5.8
25	16	5.5	36	36	5.65
26	34	5.06	37	30	5.87
27	35	5.3	38	28	5.9
28	70	5.46	39	13	5.6
29	92	5.5	40	18	5.9
30	81	5.46	41	16	5.9
31	68	5.7	42	10	6.1
32	59	5.6	43	7	6.2
33	60	5.7	44	3	6.3
34	54	5.76			

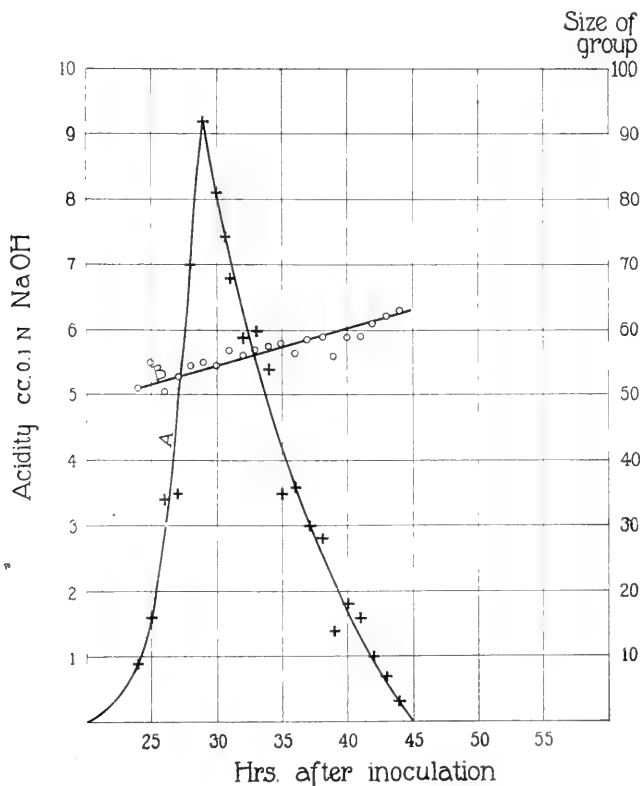

CHART 3. The curves are based on the figures contained in Table IV.

of the groups were then calculated. These results are given in Table IV. The acidity readings are for 10 cc. samples in terms of $0.1 \times \text{NaOH}$.

These results are represented by curves in Chart 3. Curve B shows the maximum acidity readings, and furnishes evidence in support of the view that the rate of the fermentation and the acidity of the medium are correlated. Curve A represents the number of examples in each group, and is thus a normal distribution curve of fermentations for the time occupied. These figures were calculated for the period from the time of inoculation to the end of fermentation. For a period of approximately 8 hours the filling of the tank was in progress, and therefore these figures cannot be compared directly with those relating to fermentations of a known volume of medium, inoculated at a given time and afterwards allowed to ferment undisturbed.

Isolation and Identification of Volatile Organic Acids.

The following is a description of the methods used on three occasions when the acids have been obtained and identified. Batches of 50 gallons of mash were prepared, sterilized, and fermented in a copper vessel in the laboratory. During the early stages of the fermentation the acidity of the mash was determined at regular intervals. When successive readings indicated that the acidity was approaching the maximum, the vessel was connected to an adjacent water-cooled, coil condenser. The contents were quickly raised to boiling point, and about 13 gallons of distillate collected in large glass vessels. The whole distillate was saturated with common salt, and extracted with 1,500 cc. of ether. After separating, the ether-soluble fraction was filtered and the ether partially removed by distillation from a water bath maintained below 40°C . The mixture of neutral and acid products of the fermentation was diluted with an equal volume of distilled water. The amount of acid present was estimated in terms of butyric acid and the mixture was then completely neutralized with twice the required amount of calcium carbonate. After an interval of several hours the excess carbonate was removed by filtration under pressure, and was then washed with distilled water. The combined solutions of calcium salts were

evaporated to dryness on the steam bath, and the residues obtained were more thoroughly freed from traces of the neutral compounds by dry heat in the oven, maintained at 100°C. The dry salts were weighed and the amount of sulfuric acid required to liberate the organic acids was calculated. An excess of dilute sulfuric was then added to the salts. The mixture was extracted with two batches of ether, and the united portions of ether-soluble material were distilled in the following manner.

The ether was removed on the water bath maintained at temperatures below 40°C. The fractions of the remainder which came over below 130°C. were removed at atmospheric pressure, and the residue was distilled under reduced pressure. The following results are from the records of these experiments.

Experiment 4.—

	A.	B.
Calcium salts obtained.....	150 gm.	112 gm.
Mixture of acids distilled.....	80.00 cc.	88.00 cc.

Distillation 1.

Fraction:

	A. cc.	B. cc.
(a) Below 40°C.....	0.00	15.3
(b) 40–70°C.....	0.00	0.00
(c) 70–105°C.....	0.00	1.40
(d) 105–130°C.....	11.00	12.70
(e) Above 130°C.....	67.00	55.00

Practically the whole 105–130°C. fraction came over between 117–122°C.

Distillation 2.

The residues boiling above 130°C., *i.e.* Fraction (e) from Distillation 1, were combined and fractionally distilled under reduced pressure. The whole of this batch, with the exception of a small residue, came over while the thermometer fluctuated between 77–79°C. The corrected boiling point of the fraction was found to be 163.3°C.

Esterification.—The combined fractions for the temperature interval 105–130°C. amounted to 22 cc. when recovered from the containers. An equal volume of ethyl alcohol and 1 cc. of concentrated H₂SO₄ were added to the fraction, and the mixture was digested for 3 hours in a small flask below a spiral condenser. After cooling under the tap the products of the digestion were neutralized with successive washings of dilute sodium carbonate. The ester layer was separated and shaken with a small volume of distilled water containing an excess of calcium chloride. The

ester layer was again separated and placed over anhydrous calcium chloride for 24 hours. The upper layer, free from water and traces of alcohol, was then distilled at atmospheric pressure.

Distillation 3.

Volume of ester layer distilled.....	21.60 cc.
Fraction 74-80°C.....	14.30 "
Residue.....	4.40 "
Summary of results from Experiment 4.	
Temperature interval of first large fraction.....	117-122°C.
(B.P. of acetic acid).....	118 "
Temperature interval covered during the distillation of the ethyl ester prepared from this fraction.....	74-80 "
(B.P. of ethyl acetate).....	77 "
Corrected B.P. of the fraction obtained from D2.....	163.3 "
(B.P. of <i>n</i> butyric acid).....	163.0 "

These results indicate that during the fermentation acetic acid and a larger quantity of *n* butyric acid are formed. There remains however the possibility that smaller amounts of one or more other acids are formed. Although the experiments described were conducted with care, and as far as possible loss of material was avoided during the various stages, it is not considered advisable to draw any quantitative conclusions from the results obtained. They confirm the results of investigations by Henley (4) and his collaborators, who have also obtained results of a quantitative character. Our major problem has now been simplified and can be stated in the following terms. What is the relation, in the biochemical system of the fermentation, between acetic and *n* butyric acids and the neutral products of the fermentation, acetone and the two alcohols, ethyl and butyl?

Relation between the Formation of the Neutral Products and Changes in the Acidity of the Medium.

The following experiments were performed to find out the relation in time between the changing acidity of the mash and the rate of the formation of the neutral products.

Experiment 5.—25 pounds of meal were added to approximately 40 gallons of cold water, in a large copper fermentation vessel. The mixture was well stirred by means of a motor-driven apparatus, and the vessel contents were slowly raised to boiling point by means of live steam. The mash so

prepared was then sterilized in the same closed vessel for 3 hours at 7 to 8 pounds steam pressure. At the close of this period the volume of the batch was approximately 66 gallons, and after cooling the mash it contained roughly 4 per cent of solids. The culture added was 6 liters of an active culture of the bacillus in 5 per cent maize mash. During the fermentation the temperature of the vessel was maintained at 98°F. After 10 hours of the fermentation period the acidity of medium was determined at regular intervals. Samples, 150 cc. in volume, were withdrawn at intervals of 2 hours and distilled. The distillate collected from each of these was 50 cc. in volume and was made up accurately to 100 cc. with distilled water. The acetone content of each sample was determined by titration, using the Messinger method. The results obtained from this experiment are presented in Table V.

TABLE V.

Date.	Time after inoculation.	0.1 N NaOH required for 10 cc. sample.	Acetone in 150 cc. sample.
1919	hrs.	cc.	gm.
Apr. 9,	10.00 a.m.	1.15	0.005
	12.00 n.	1.80	0.004
	2.00 p.m.	2.65	0.005
	4.00 "	3.71	0.008
	6.00 "	4.36	0.010
	8.00 "	5.06	0.021
	10.00 "	5.59	0.049
	11.30 "	23.5	5.60
May 9,	9.00 a.m.	3.82	
	10.00 "	3.74	0.256
	12.00 n.	3.62	0.274
	2.00 p.m.	3.19	0.317
	4.00 "	3.15	0.309
	6.00 "	2.90	0.326
	8.00 "	2.85	0.331
June 9,	10.00 a.m.	3.13	0.356
	12.00 n.	60	0.368

Experiment 6.—The last experiment was repeated with the exception that an effort was made to obtain results showing the rate of the formation of alcohols. The same tests were made as in Experiment 5 and in addition a number of larger samples, 2,000 cc. in volume, were distilled at regular intervals of time during the fermentation. About 300 cc. of distillate were collected from each one and redistilled from a 500 cc. flask, using as a still-head a three-section Young's fractionating column. The distillate from each sample was completely saturated with K_2CO_3 and allowed to stand over an excess for 60 hours in the refrigerator. The oil layer from each sample was separated and measured by volume. By the method

previously described the weight of acetone, and therefore the volume, present in the 2,000 cc. samples was estimated. From these two figures it is possible to obtain, by difference, the volume of the mixture of the two alcohols in the total volume of neutral products in the sample. Owing to the presence of water in the oil the results so obtained do not represent dry, pure alcohol. The amount of water is not considerable and the results, in spite of this error, do give us the information required; *i.e.*, the relation between the rate of formation of the alcohols and the changes in acidity of the medium. The results of this experiment are given in Table VI.

TABLE VI.

Date.	Time after inoculation.	0.1 N NaOH required for 10 cc. sample.	Acetone per 150 cc.	Acetone per 2,000 cc.	Total oil per 2,000 cc.	Total alcohol per 3,000 cc.
	<i>hrs.</i>	<i>cc.</i>	<i>gm.</i>	<i>cc.</i>	<i>cc.</i>	<i>cc.</i>
1919 Sept. 16.	9.30 a.m.	11	2.60	0.010	0.30	0.30
	11.30 "	13	3.95	0.024	0.40	0.20
	1.30 p.m.	15	4.80	0.040	0.66	0.34
	3.30 "	17	5.39	0.068	1.00	1.50
	5.30 "	19	5.33	0.111	1.85	1.75
	7.30 "	21	4.90	0.174	2.90	3.70
	9.30 "	23	4.25	0.243	4.05	6.75
10.30 "	24	3.94				
Sept. 17.	9.30 a.m.	35	1.85	0.616	10.27	20.73
	11.30 "	37	2.06	0.628	10.47	23.03
	1.30 p.m.	39	2.07	0.656	10.94	Lost.
	3.30 "	41	2.09	0.655	10.92	35.00
	5.30 "	43	2.10	0.675	11.25	35.00
	7.30 "	45	2.20	0.663*	11.05	35.00
Sept. 18.	9.30 a.m.	59	2.31	0.673	11.22	35.50
	1.30 p.m.	63	2.35	0.652*	10.87	Lost.

* Acetone low on account of loss during distillation. The results obtained in Experiment 6 are represented in the form of curves in Chart 4.

The curves in Chart 4 show that during the first phase of the fermentation period, when the hydrolysis of starch and the increase in the acidity of the medium are in progress, there is little formation of the alcohols or acetone. Towards the close of this phase formation commences at a slow rate. During the second phase, when we find a diminution in the amount of free acid, the neutral compounds are produced with great rapidity. This is also the time during which we have already observed a marked increase in the rate of gas production. It is interesting also to

compare the relative amounts of acetone and the alcohols in the early samples analyzed with the amounts in the final sample. We find that the early ones contain more acetone than alcohol; whereas the final sample contains approximately twice as much alcohol as acetone. These facts suggest that the formation of

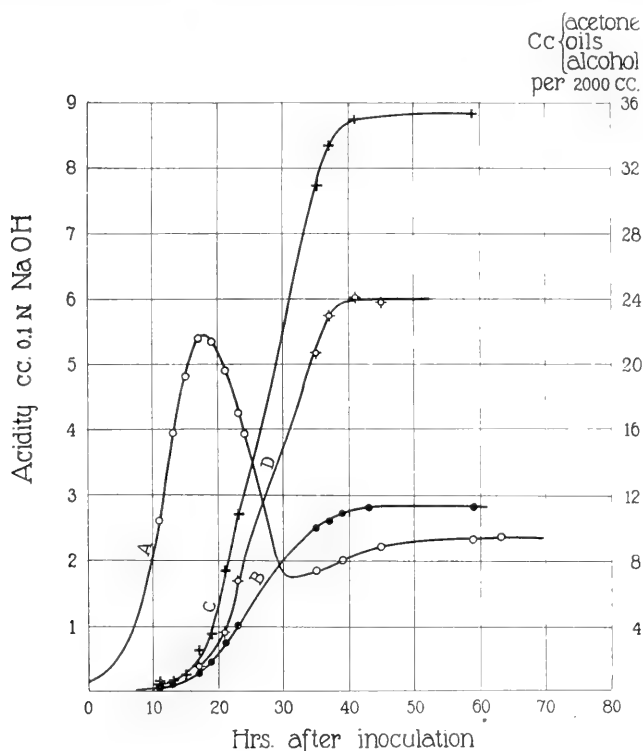

CHART 4. Curve A is the acidity curve and Curves B, C, and D the rate of production curves of acetone, total neutral products (oils), and alcohols respectively of the fermentation described in Experiment 6.

acetone commences slightly earlier than that of the alcohols. During the final phase of the fermentation, when the acidity of the medium rises very slowly to a constant, there is a very pronounced fall in the rate of production of acetone and alcohol until the end of the fermentation.

Acidity Changes during the Fermentation of Mash Previously Acidified with Various Organic Acids.

A large number of experiments have been performed in which small volumes of organic acid have been added to the medium at different points in the fermentation period. For example, varying amounts of butyric acid were added to a number of flask cultures at a point when the acidity of the medium was falling rapidly. In a typical case an increase in acidity equivalent to 1.1 cc. of 0.1 N NaOH per 10 cc. of mash was brought about. This addition had no harmful effect on the culture, and, what is equally significant, the final acidity of the flask was normal, 10 cc. = 2.3 cc. of 0.1 N NaOH.

TABLE VII.

Date.	Time after inoculation.*	Cc. 0.1 N NaOH required for 10 cc. sample.		
		Control flask.	Acetic flask.	Butyric flask.
	hrs.	cc.	cc.	cc.
1918				
Jan. 16, 5.00 p.m.	0		3.60	3.50
" 17, 10.30 a.m.	17.5	3.60	4.00	3.40
12.00 n.	19	4.00	4.40	3.90
4.00 p.m.	23	3.60	5.00	4.30
Jan. 18, 10.00 a.m.	41	2.00	2.30	3.00
12.00 n.	43	2.20	2.20	2.30

* The flasks were inoculated at 5.00 p.m., Jan. 16, 1918.

In a second group of experiments the acid was added before inoculation. The acidity changes of each flask were followed, and as the experiment was repeated the initial acidity of the medium, due to free organic acid, was increased. Finally sufficient acid had been added to inhibit the life processes of the bacillus. In other flasks with a lower initial acidity, the fermentation was only retarded. The following is a description in greater detail of such a series of flasks.

Experiment 7.—Three flasks each containing 750 cc. of 5 per cent maize mash were sterilized for 2.5 hours at 10 pounds steam pressure. Flask A acted as a control, Flask B was acidified with acetic acid, and Flask C was acidified with butyric acid. The three flasks were inoculated at the same time with equal amounts of culture and were incubated together. The acidity of the flasks was determined at intervals. At the close of the

fermentation the flasks were similar in external appearance. The starch was completely hydrolyzed and the flasks contained clear yellowish green fluid upon which the slimy albuminous residue was floating. The results from this experiment are presented in Table VII.

The results show that during the fermentation of Flasks A and B a portion at least of the organic acid added to the flasks was involved in some biochemical reaction with the result that it was converted into some essentially different substance. Similar results were obtained when a sufficient amount of propionic acid was added to the mash previous to inoculation. An effort was then made to isolate and identify the compounds produced by the reaction involving the organic acids.

Quantitative Experiments Showing the Compounds Produced during the Fermentation of Mash Plus Various Organic Acids.

The object of the experiment was to determine the nature and volume of the neutral products of fermentations of maize mash to which known quantities of acetic, propionic, or butyric acid have been added previous to inoculation. The general method adopted was to ferment flasks of medium of known volume and concentration, to which the acid was added, and at the close of the fermentation to isolate, measure, and identify the various compounds by careful fractional distillation. The flasks were arranged in groups according to the nature of the organic acid added to the mash.

Experiment 8.—Group A.—10 liters of mash were prepared containing 400 gm. of maize meal. The mash was sterilized for 2.5 hours in the autoclave at 10 pounds steam pressure. This group was the control for the experiment.

Group B.—Eight flasks containing an equal volume of mash of the same concentration, and sterilized in the same manner. To each flask 2.5 cc. of glacial acetic acid were added previous to inoculation.

Group C.—Eight flasks similar to those in Group A, with 3.0 cc. of propionic acid added to each flask before inoculation.

Group D.—Eight flasks similar to the above, to which 3.0 cc. of butyric acid were added.

The acid was added when the flasks had cooled, and they were then inoculated, each with 50 cc. of an active culture of the bacillus in 5 per cent mash, used 20 hours after inoculation. The flasks of the four groups were incubated at 36.5°C., and during the fermentation period they were

336 Biochemistry of *B. granulobacter pectinovorum*

not disturbed in any way. In all cases the mash was completely fermented. The contents of the different groups of flasks were then examined in the following manner.

Distillation 1 (D1).—The 10 liters of beer from each group were distilled from a large copper vessel. The distillate was condensed in a straight glass tube condenser, and was collected until it no longer contained traces of butyl alcohol. Approximately 1,500 cc. were obtained from each group.

Distillation 2 (D2).—The distillate from D1 of each group was partially saturated with NaCl and redistilled from a flask. A three-section Young's fractionating column was used for a still-head. The distillation was continued in each case until all the butyl had passed over.

Distillation 3 (D3).—The second distillation was repeated using a smaller flask. The fractions boiling above and below 75°C. were collected in different receivers. The higher boiling fraction was shaken with a con-

TABLE VIII.

Temperature interval.	Volume of fraction.			
	Control.	Acetic group.	Propionic group.	Butyric group.
°C.	cc.	cc.	cc.	cc.
Below 65.	24.00	33.75	32.50	29.50
65-75	6.00	9.75	7.00	3.50
75-85	6.00	5.00	9.75	10.00
85-90.5	11.00	9.50	13.00	8.00
90.5-105	4.00	6.25	4.75	5.00
105-115	8.00	8.00	23.00	12.50
Above 115.	58.00	59.00	49.00	72.50
Total volume.....	117.00	131.25	139.00	141.00
Volume of acid added to mash.	0.00	20.00	24.00	24.00

siderable amount of K_2CO_3 and allowed to stand over an excess for 24 hours. The upper layer was separated from the aqueous layer and restored to the lower boiling fraction. The combined fractions were redistilled.

Distillation 4 (D4).—For this distillation a smaller column, made up of three bulbs each containing one loose, blown glass bead, was used. The temperature intervals adopted and the volumes of the fractions obtained for the four groups of flasks are embodied in Table VIII.

The small residue is in each case included in the final fraction. From the relatively small volume of the fraction obtained between 90.5-105°C. in each case we may conclude that the amount of water present was very small, and from the uniformity of the fractions from the four series that the amount still present in the

distillates was approximately the same in all cases. In the three series of flasks to which the acids were added previous to inoculation there was a considerable increase in the volume of neutral products of the fermentation. When the results of the experiment are considered in greater detail we find that (a) in the acetic series there was an increase of 45 per cent in the products boiling below 75°C., and smaller differences in the higher fractions when compared with those obtained from the control; (b) in the propionic series there was an increase of 31.7 per cent in the fractions boiling below 75°C., an increase of 187.5 per cent in the fraction boiling between 105–115°C., and a decrease in the fraction boiling above 115°C. of 15.5 per cent; and (c) in the butyric series there was an increase of 10 per cent in the fractions boiling below 75°C., and an increase of 25 per cent in the fraction boiling above 115°C. The results obtained from this experiment were verified three times before proceeding further with the research. An effort was then made to elucidate the nature of the compounds produced from the propionic acid series.

From the results obtained in the butyric acid series it was clear that there was a large increase in the production of butyl alcohol. There seemed to be strong evidence for the assumption that this was produced during the fermentation from the acid added to the mash. If propyl alcohol were produced from the acid added to the third series, in what fractions would it appear in the final distillation? In this connection it was recalled that of the ethyl alcohol produced during the normal fermentation the majority is found with butyl alcohol and water in the 85–91°C. fraction. Using pure propyl and butyl alcohols it was then found what results were obtained when a mixture of the two was fractionally distilled.

Experiment 9.—(A). A known volume of butyl alcohol was distilled using the apparatus which had been used in D3 and D4 of Experiment 8. The following figures relate to this distillation.

	cc.	cc.
Volume of butyl alcohol distilled.....	75.00	60.00
Fraction boiling below 105°C.....	0.00	0.00
“ “ from 105–115°C.....	3.00	4.50
“ “ above 115°C.....	72.50	55.50

(B). A mixture of the pure alcohols, with butyl alcohol in excess, was then distilled.

338 Biochemistry of *B. granulobacter pectinovorum*

	cc.	cc.
Volume of butyl in the mixture.....	75.00	60.00
“ “ propyl “ “	5.00	5.00
Fraction boiling below 105°C.....	1.00	0.00
“ “ from 105-115°C.....	15.00	17.00

From these results it was concluded that when such a mixture of the two alcohols is distilled a large fraction containing both alcohols comes over between 105-115°C.

Experiment 10.—The object of this experiment was to obtain a larger volume of the unknown fraction in the products from the mash plus propionic acid fermentation. Mash was prepared containing 2,000 gm. of meal and was then made up to 50 liters. After sterilization the mash was allowed to cool and 120 cc. of propionic acid were added. The same per-

TABLE IX.

Temperature interval.	Volume of fraction.		Temperature interval.
	Experiment 10.*	Group 3, Experiment 8.	
°C.	cc.	cc.	°C.
57-65	197.00	32.50	Below 65.
65-75	12.00	7.00	65-75
75-85	35.00	9.75	75-85
85-95	26.00	13.00	85-90.5
95-105	47.00	4.75	90.5-105
105-115	43.50	23.00	105-115
Above 115.	297.00	49.00	Above 115.
Total volume..	657.50	139.00	

* The amounts used in Experiment 10 were five times those used in Group 3, Experiment 8.

centage of inoculant was added as in the last experiment and the fermentation was allowed to proceed undisturbed in the incubator at 36.5°C. The products of the fermentation were analyzed by distillation in the manner previously described. Traces of water were removed by salting out the alcohol from the 90.5-95°C. fraction. The results obtained from this experiment after the middle fractions had been redistilled several times are given in Table IX. The results obtained from D4, Experiment 8, of flasks containing propionic acid are included for comparative purposes.

The figures indicate that in the redistillation of the middle fractions, as the acetone, butyl alcohol, and water contained in them are eliminated, the relative volumes of these fractions change and progressive increases are observed in the 75-85 and 95-105°C.

fractions. As we have already observed, the accumulation of distillate in the first of these fractions is due to the gradual purification of the ethyl alcohol. The formation of the second of these large fractions was due to the presence of propyl alcohol which was gradually separated from the larger volume of butyl alcohol. From the fractions boiling above 95°C. shown in Table IX, 37.00 cc. of propyl alcohol were obtained.

Discussion of Experiments 8, 9, and 10.

In our consideration of the facts established by a comparison of the nature and volume of the compounds produced during the normal and abnormal fermentations, attention is called only to

TABLE X.

		<i>per cent</i>	<i>per cent</i>
Mash plus 0.2 per cent acetic acid by volume.	Increase in the yield of acetone.....	45.0	
	“ “ volume of ethyl alcohol in terms of acetic acid added.....		0.00
Mash plus 0.24 per cent propionic acid by volume.	Increase in the yield of acetone.....	30.0	
	“ “ “ “ “ propyl alcohol in terms of propionic added.....		30.0
Mash plus 0.24 per cent butyric acid by volume.	Increase in the yield of acetone.....	10.0	
	“ “ “ “ “ butyl alcohol in terms of butyric added.....		80.0

differences regarding the existence of which there does not appear to be room for doubt. With regard to the results obtained from the flasks containing mash plus acetic acid, a slight increase in the yield of butyl alcohol was observed, but further investigation is deemed necessary before this can be regarded as a characteristic result of such an experiment. There remains also the possibility that, working with larger volumes of mash to which a larger percentage of acetic acid has been added before inoculation, an increase in the production of ethyl alcohol might be produced.

Neglecting these possibilities, from the results obtained it has been calculated what the increase in the yield of acetone was in each group of flasks, and approximately what was the ratio between the alcohol equivalent of the amount of the organic acid

340 Biochemistry of *B. granulobacter pectinovorum*

added, and the increase in the production of the corresponding alcohol. It was assumed from the results obtained in Experiment 10 that, when 120 cc. of propionic acid are added to 50 liters of mash, 37 cc. of propyl alcohol are formed. This estimate disregards the propyl present in the final 99–115°C. fraction which was too small in volume to refractionate. The figures in Table X regarding the acetic and butyric experiments are based on the results of Experiment 8.

DISCUSSION.

From the foregoing experiments it is clear that the organism when growing in a medium rich in starch secretes an enzyme, or group of enzymes, which hydrolyzes the starch to glucose. The sugar passes into the cell and by its oxidation acetic and α butyric acids are produced.

It is interesting to compare the sugar and the two acids produced with the acids formed during the fermentation of xylose (5). In both cases the sum of the carbon atoms in the two acids is the number of carbon atoms in the sugar from which they are derived.

The acidity of the fermentation gradually rises. At a slightly later stage another process commences; namely, the conversion of the acids into substances which are neutral. Eventually the second process is more active than the first and there is for several hours a flow of acid into the cell from the medium. Towards the end of the fermentation the balance is again reversed and the acidity of the medium rises slightly once more. The method adopted for the determination of the acidity only serves to indicate the balance between the acid-forming and acid-destroying systems and does not furnish data regarding the true acidity of the normal fermentation.

The experiments showing the variations in the acidity of fermenting media of different concentrations, and of abnormal fermentations due to the temperature conditions or the low vitality of the organism, indicate that the formation and destruction of the acids are not independent of but are essential parts of the biochemical system responsible for the formation of the alcohols and acetone. It has been shown that the period during which the destruction of the acids is most active is the period during

which the neutral products are being most rapidly formed. These facts can be explained by the hypothesis that the organic acids are intermediate compounds in the fermentation.

We shall discuss in the first place the evidence supporting the hypothesis that the acids are reduced to the alcohols. When acetic, propionic, and butyric acids were added to different portions of mash, equal in volume and concentration, it was found that there was no change in the yield of ethyl alcohol, that propyl alcohol was formed, and that there was a large increase in the yield of butyl alcohol. Now if the acids give rise to the alcohols in the normal fermentation, why was there no marked increase in the yield of ethyl alcohol when acetic acid was added to the mash? In order to increase the yield of the corresponding alcohol the acid must pass through the cell wall. What are the factors present under the conditions obtaining, which are known to influence the penetration of cell walls by acid? The cells were immersed in solutions of acids, present in varying concentrations. When the flow of acid into the cells started in the acetic flasks the order of concentration was: butyric = acetic; in the propionic flasks: butyric = propionic > acetic; and in the butyric flasks: butyric > acetic. Crozier (6) has shown, working with animal cells and 0.01 \times solutions of the fatty acids, that the order of penetration among the lower members of the series is as follows: valeric > butyric > propionic > acetic. Harvey (7) has obtained similar results, also working with animal cells. Haas (8) arrived at a similar conclusion from experiments on the penetration of living plant cells by 0.01 \times solutions, made by titration, of acids and alkalies. Very different results were obtained when the acid solutions were standardized by the gas chain method. If the same law of penetration applies when bacteria are used, and if the acid passing through the wall is converted to the corresponding alcohol, then the increases in the yields of the alcohols, expressed as ratios of the alcohol equivalents of the amounts of the different acids added to the mash, should correspond to the order of penetration. The figures in the right hand column of Table X do so in a very striking manner. Reilly (4) has observed that in the later part of the fermentation, *i.e.* when acid is passing into the cell, the percentage of acetic acid in the total free acid increases. The results of these experiments show that during the normal fermentation the two acids are reduced to the corresponding alcohols.

We shall now consider the results in relation to the production of acetone. We observe that during the rapid destruction of the acids formed during the normal fermentation there is a corresponding production of acetone, and that without the first the second does not occur. Is it possible that acetone is also formed from one or both of the acids? From the flasks to which various acids were added largely increased yields of acetone were obtained. Reilly ⁴ has made similar observations in connection with acetic acid. He states:

"It appeared that the bacteria or enzymes were actually able to reduce the acetic acidity in considerable quantities. The percentage of acetone was increased by the addition of acetic acid. If acetic acid were made by an ordinary fermentation process, for example, by souring cheap wines, the dilute solution could be pumped directly into the fermentation vat for conversion into acetone."

Our results show that if we assume a conversion of acetic acid into acetone, we must in the end assume the presence in the cell of some system by which acetone is formed from the three acids, acetic, propionic, and butyric. This is highly improbable. Furthermore if the acid passing through the cell wall is partially converted into acetone we should expect the largest increase in yield from the butyric acid flasks, for, as we have observed earlier in the discussion, the acids penetrate the cell wall in increasing amounts as we ascend the series. It was found that the increase in the yield of acetone diminishes in a regular manner as we ascend the series. For these reasons I conclude that the yield of acetone is affected by influences exerted by an acid on intercellular life by virtue of its properties and presence in the surrounding solution only and not by conversion into acetone within the cell.

Although the acetone is not produced from acid which passes from the medium into the cell, is it formed from organic acid which flows directly from the acid-producing to the acetone-producing region in the cell. It is also necessary to assume that the acid passing into the cell does not reach the acetone system. Such an organization might be influenced in the manner described by the presence of large quantities of acid in the mash before inoculation, for example, by restricting the flow of acid from the cell. For theoretical reasons it does not seem probable that acetone is produced from acetic acid, but there remains the possibility with

regard to butyric acid. Witzemann (9) has shown that acetone is produced by the oxidation of butyric acid by means of hydrogen peroxide. It would seem advisable however to leave this portion of our problem for further investigation.

CONCLUSIONS.

From the results obtained by this investigation we conclude that:

1. *Bacillus granulobacter pectinovorum* growing in a medium rich in starch changes the latter into glucose by exoenzyme activity.
2. Glucose passes into the cell and is oxidized to acetic and butyric acids.
3. These acids are in part reduced to the corresponding alcohols.

I wish to thank my colleague Mr. A. M. Wynne for his assistance during the prosecution of this research.

BIBLIOGRAPHY.

1. Northrop, J. H., Ashe, L. H., and Morgan, R. R., *J. Ind. and Eng. Chem.*, 1919, xi, 723.
2. Speakman, H. B., *J. Soc. Chem. Ind.*, 1919, xxxviii, 155.
3. Northrop, J. H., Ashe, L. H., and Senior, J. K., *J. Biol. Chem.*, 1919, xxxix, 1.
4. Nathan, F., *J. Soc. Chem. Ind.*, 1919, xxxviii, 271.
5. Fred, E. B., Peterson, W. H., and Davenport, A., *J. Biol. Chem.*, 1919, xxxix, 347.
6. Crozier, W. J., *J. Biol. Chem.*, 1916, xxiv, 255.
7. Harvey, E. N., *Am. J. Physiol.*, 1912-13, xxxi, 335.
8. Haas, A. R., *J. Biol. Chem.*, 1916, xxvii, 225.
9. Witzemann, E. J., *J. Biol. Chem.*, 1918, xxxv, 83.



DETERMINATION OF CHLORIDES IN WHOLE BLOOD.

BY J. HAROLD AUSTIN AND DONALD D. VAN SLYKE.

(From the Hospital of The Rockefeller Institute for Medical Research.)

(Received for publication, January 26, 1920.)

As it is desirable at times to determine the chloride content of the whole blood rather than of the plasma only, the applicability to this purpose of the Van Slyke-Donleavy method¹ for the determination of plasma chlorides was investigated.

It was found that some component of the laked cells other than the chloride has the property of binding silver, so that the direct application of the Van Slyke-Donleavy method to whole blood gives readings too high by 30 to 40 per cent. If, however, after laking, the protein is precipitated by picric acid alone, or by picric and nitric acids, and the protein-free filtrate is treated with silver nitrate, a quantitative precipitation of the total chloride of the whole blood is obtained and the final titration may be carried out as in the Van Slyke-Donleavy method. The accuracy of this modification was tested on whole oxalated ox blood by comparison with chloride estimation by the Carius method, using the technique for destroying the organic matter adopted by Vinograd² and a Volhard titration of the silver remaining unbound.

Carius Method.

Whole oxalated ox blood was analyzed for chloride content by the Carius method as follows.

Approximately 1 cc. of the whole blood was introduced from a pipette into the bottom of a bomb tube and the amount accurately determined by weighing the pipette before and after delivery.

¹ Van Slyke, D. D., and Donleavy, J. J., *J. Biol. Chem.*, 1919, xxxvii, 551.

² Vinograd, M., *J. Am. Chem. Soc.*, 1914, xxxvi, 1548, also *Studies from The Rockefeller Institute for Medical Research*, 1915, xxii, 372.

1 cc. of a solution of silver nitrate containing 20.4 mg. of AgNO_3 per cc. was carefully introduced into the bottom of the tube. The tube was then immersed in a water bath at 100° and the moisture-laden air in the upper portion of the tube continually removed by aspiration until the water was driven from the mixture of blood and silver nitrate. 1 cc. of fuming nitric acid in a small tube was then introduced into the tube. The tube after being sealed was slowly heated to 180° and this temperature maintained for 3 hours. After cooling, opening, and washing out the colorless solution with distilled water the remaining unprecipitated silver was titrated by Volhard's method with a 0.015 M solution of NH_4CNS , the chloride obtained by difference being expressed as NaCl . The results of four determinations are given in Table I.

Results with Modified Van Slyke-Donleavy Method.

Into each of two 50 cc. volumetric flasks were introduced 4 cc. of the same whole oxalated ox blood used in the Carius analysis and the weight of blood introduced was determined by weighing the flasks before and after introduction of the blood. After laking by addition of 20 cc. of distilled water, there were added 20 cc. of the following solution of nitric and picric acids:

HNO_3 (sp. gr. 1.42).....	cc. 250.0
Picric acid.....	7.5
Distilled water to.....	1,000.0

The flask was then filled to the mark with distilled water and repeatedly inverted. After allowing 10 minutes for complete precipitation of the protein, the mixture was filtered through a dry filter and 25 cc. of the clear yellow filtrate were introduced into a 50 cc. volumetric flask. To this were added 10 cc. of an $\text{M}/29.25$ AgNO_3 solution, the flask was filled to the mark, and two drops of caprylic alcohol were added. After standing overnight (to promote clear filtration) the clear supernatant fluid was removed with a pipette, filtered, and two 20 cc. portions were taken. These were titrated with KI solution after addition of 4 cc. of the special starch solution as described in the Van Slyke-Donleavy method.

The results of four determinations are given, together with those on the same blood by the Carius method, in Table I. In the last column are given also the results obtained in attempting to apply the Van Slyke-Donleavy method, without modification, to whole blood.

The chief difficulty encountered in the present method was in securing a clear filtrate after the precipitation of the AgCl. This is probably somewhat facilitated by using more picric acid and

TABLE I.

Results of Chloride Determinations on a Specimen of Whole Blood.

Carius method.			Van Slyke-Donleavy method modified for whole blood by precipitating proteins and AgCl separately.		VanSlyke-Donleavy method for plasma applied to whole blood without modification.
Weight of blood.	NaCl found.	NaCl found per gm. of blood.	Weight of blood.	NaCl found per gm. of blood.	NaCl found per gm. of blood.
<i>gm.</i>	<i>mg.</i>	<i>mg.</i>	<i>gm.</i>	<i>mg.</i>	<i>mg.</i>
0.998	4.47	4.48	4.108	4.53	6.00
1.000	4.54	4.54		4.53	5.95
1.005	4.57	4.55	4.113	4.54	5.98
1.002	4.57	4.56		4.53	6.05
Average		4.53		4.53	5.99

less nitric acid for the precipitation of the protein, then adding the required amount of nitric acid to the final 20 cc. portions just before addition of the starch solution. The most effective means of securing a clear filtrate, however, is by permitting the solution to stand in the dark over night after the addition of the silver nitrate; a perfectly clear supernatant liquid can then be pipetted from the flask.

The technique finally adopted is as follows.

Method for Determination of Chlorides in Whole Blood.

Take 3 cc. of blood with 15 cc. of water in a 60 cc. flask. Add 30 cc. of saturated picric acid solution and sufficient water to bring the volume to 60 cc. (27 cc. of water in all, and 30 cc. of picric acid may be measured from burettes if a 60 cc. measuring flask is not available). The contents of the flask are mixed, and after 10 minutes are filtered.

To 40 cc. of the filtrate 10 cc. of the $M/29.25$ silver nitrate solution used by McLean and Van Slyke³ are added, with two drops of caprylic alcohol (the silver solution contains per liter 5.812 gm. of $AgNO_3$ and 250 cc. of HNO_3 (sp. gr. 1.42)). The solutions are thoroughly mixed, and preferably allowed to stand overnight to allow the $AgCl$ to coagulate and settle. The supernatant solution is decanted through a small filter paper, and 20 cc. are titrated as described by Van Slyke and Donleavy. The calculation also is the same, since the 20 cc. of filtrate titrated in this case, as in the method of Van Slyke and Donleavy, represent 0.8 cc. of the original material, blood or blood plasma.

Attention may be called to the fact that the use of the unmodified Van Slyke-Donleavy method with a plasma that is considerably stained as the result of partial hemolysis of the cells will give values that are unduly high.

CONCLUSIONS.

1. The method described by Van Slyke and Donleavy for the determination of plasma chlorides is not directly applicable to whole or to laked blood.

2. A modified technique for whole or laked blood is described in which the precipitation and removal of the protein precede the addition of the silver.

³ McLean, F. C., and Van Slyke, D. D., *J. Biol. Chem.*, 1915, xxi, 361.

EXPERIMENTS ON THE UTILIZATION OF THE CALCIUM OF CARROTS BY MAN.

BY MARY SWARTZ ROSE.

WITH THE COOPERATION OF RENA S. ECKMAN, EDITH D. BROWNELL, EDITH HAWLEY, AND ELLA WOODS.

(From the Department of Nutrition, Teachers College, Columbia University, New York.)

(Received for publication, January 24, 1920.)

McClugage and Mendel¹ have recently called attention to the scantiness of our knowledge concerning the value of the calcium of vegetables for animal nutrition, and have described experiments with dogs in which the calcium was very poorly utilized when derived from carrots.

When that paper was published two of the four experiments reported herein had been completed, but as the results were strikingly different the work was continued with two other subjects. Each of the four subjects had shortly previous to the calcium experiment been the subject of digestion experiments with simple mixed diets, and their digestive capacity was known to be high. The carrot was chosen for special study because it is ingested comparatively easily in large amounts over considerable periods, and because it is a vegetable with a high calcium content.

Methods.

The general plan was to arrange an easily digested diet with a calcium content approximately equal to the estimated minimal requirement for equilibrium in each subject, and to determine calcium balances from the calcium content of analyzed food, urine, and feces. In Series I with two subjects, there were two periods of 3 weeks each. In Period I, milk was made the chief

¹ McClugage, H. B., and Mendel, L. B., *J. Biol. Chem.*, 1918, xxxv, 353.

source of calcium; in Period II, the milk was largely omitted and carrots were introduced to make up the full quota of calcium. It was thought that if the subjects were about in equilibrium on the milk ration, any failure to utilize the calcium would show promptly in the calcium balance. In Series I, the milk period was omitted and the carrot diet consumed for 2 weeks.

Sherman has pointed out² that in 63 experiments on ten subjects calcium equilibrium could be maintained on amounts ranging from 0.27 to 0.78 gm. of calcium per 70 kilos of body weight per

TABLE I.
Calcium Content of Foods Used in Diets.

Food material.	Calcium.
	<i>per cent</i>
Bread	0.032
Beef, lean	0.018,* 0.009,† 0.004‡
Milk	0.116
Honey, strained	0.004
Butter	0.014,* 0.010†
Peaches	0.006
Apple	0.010,* 0.0024†
Tomato juice	0.015
Rice	0.012
Coffee infusion	0.003
Carrots	0.044,* 0.052†
Soda crackers	0.025

* Series I.

† " II.

‡ " II, Periods II and III.

day with an average of 0.45 gm. In these experiments the milk diets yielded 0.48 and 0.50 gm. per 70 kilos and the carrot diets from 0.39 to 0.46 gm. Only distilled water was used throughout.

Urine and feces were collected daily and combined into 4 day periods for analysis. The carrots were boiled in their skins, in just enough water to steam them, then the skins removed, the carrots mashed, mixed, and sampled for analysis. Calcium was determined by McCrudden's method.

The calcium content of the foods used in the daily diets is given in Table I.

² Sherman, H. C., *Chemistry of food and nutrition*, New York, 2nd edition, 1918, 264.

EXPERIMENTAL.

In Series I, the two young women had so nearly the same energy requirement that they decided to eat exactly the same amounts of food throughout. The time was divided into two periods of 3 weeks each. In Period I, 70 per cent of the calcium intake came from milk; in Period II, 21 per cent from milk and 55 per cent from carrots. The calcium content of the daily diets is given in Table II.

TABLE II.

Calcium Content of Daily Diets. Series I.
Subjects E. D. B. and R. S. E.

Food.	Period I.		Period II.	
	Weight.	Calcium.	Weight.	Calcium.
	<i>gm.</i>	<i>gm.</i>	<i>gm.</i>	<i>gm.</i>
Bread.....	152	0.0476	152	0.0477
Meat.....	100	0.0169	50	0.0086
Milk.....	226	0.2644	57	0.0668
Honey.....	31	0.0011	31	0.0015
Butter.....	50	0.0072	50	0.0072
Sugar.....	30		50	
Rice.....	57	0.0069	29	0.0035
Peaches.....	106	0.0068		
Apple.....	100	0.0100		
Tomato juice.....	100	0.0150		
Coffee infusion.....	200	0.0063	200	0.0057
Carrots.....			400	0.1744
Total per day.....		0.3822		0.3154
“ “ kg. R. S. E.....		0.0068		0.0056
“ “ “ E. D. B.....		0.0071		0.0058

The lower calcium intake in Period II was regrettable as it introduced the possibility of an actual calcium deficiency, but the final balances showed that requirement was fully met in the case of E. D. B., though perhaps not quite in that of R. S. E. This change came about through the inability of the subjects to consume as large amounts of the carrots as they had intended. On account of the bulkiness of the diet, the rice was reduced in Period II. The tomato juice, peaches, and apple used in Period I to keep the diet laxative were dispensed with when carrots were introduced.

Calcium of Carrots

Both subjects lost calcium during the first 4 day period. This was attributed to their changing from a high to a low calcium

TABLE III.
Daily Intake and Output of Calcium, Series I.

Subject E. D. B., weight 54 kg.

Series.	Period.	Time.	Average daily intake of calcium.	Average daily output of calcium.			Calcium balance.
				Urine.	Feces.	Total.	
		<i>days</i>	<i>gm.</i>	<i>gm.</i>	<i>gm.</i>	<i>gm.</i>	<i>gm.</i>
I	I	4	0.383	0.086	0.553	0.639	-0.225
	II	4	0.383	0.081	0.290	0.371	+0.012
	III	4	0.383	0.071	0.243	0.313	+0.070
	IV	4	0.383	0.069	0.215	0.284	+0.099
	V	5	0.383	0.056	0.267	0.323	+0.060
Average.....	II-V	17	0.383	0.070	0.254	0.323	+0.060
II	VI	4	0.315	0.033	0.133	0.166	+0.149
	VII	4	0.315	0.045	0.165	0.210	+0.105
	VIII	4	0.315	0.076	0.236	0.312	+0.004
	IX	4	0.315	0.076	0.235	0.311	+0.003
	X	5	0.315	0.060	0.239	0.299	+0.016
Average.....	VI-X	21	0.315	0.058	0.202	0.260	+0.055

Subject R. S. E., weight 56 kg.

I	I	4	0.383	0.064	0.567	0.632	-0.249
	II	4	0.383	0.070	0.264	0.334	+0.049
	III	4	0.383	0.069	0.242	0.311	+0.072
	IV	6	0.383	0.069	0.191	0.260	+0.121
Average.....	II-IV	14	0.383	0.069	0.226	0.296	+0.087
II	V	4	0.315	0.074	0.287	0.361	-0.046
	VI	4	0.315	0.077	0.189	0.266	+0.049
	VII	4	0.315	0.073	0.327	0.400	-0.084
	VIII	4	0.315	0.072	0.220	0.292	+0.023
	IX	5	0.315	0.079	0.287	0.366	-0.050
Average.....	V-IX	21	0.315	0.075	0.262	0.336	-0.022

intake and attaining equilibrium on a new level, and the period has been excluded from the averages for the period, though its inclusion would make apparently a better case for the calcium

of carrots. No such loss occurred on going from the milk to the carrot diet. Some loss at this time occurred in the case of R. S. E. who was the most liable to digestive disturbances of all the subjects, and found the carrot diet slightly less satisfactory than the others. The data for the calcium balances are given in Table III.

TABLE IV.
Calcium Content of Daily Diets. Series II.
Subject E. H.

Food.	Period I.		Period II.		Period III.
	Weight.	Calcium.	Weight.	Calcium.	Calcium.
	<i>gm.</i>	<i>gm.</i>	<i>gm.</i>	<i>gm.</i>	<i>gm.</i>
Meat.....	100	0.0090	150	0.0100	0.0060
Crackers.....	85	0.0213	100	0.0250	0.0250
Butter.....	70	0.0070	100	0.0100	0.0100
Sugar.....	100		100		
Apple.....	100	0.0024			
Carrots.....	466	0.2423	400	0.2080	0.2080
Total per day.....		0.2820		0.2530	0.2490
“ “ kg.....		0.0063		0.0056	0.0055

Subject E. W.

Food.	Period I.		Periods II and III.	
	Weight.	Calcium.	Weight.	Calcium.
	<i>gm.</i>	<i>gm.</i>	<i>gm.</i>	<i>gm.</i>
Meat.....	100	0.0090	100	0.0040
Soda crackers.....	150	0.0375	150	0.0375
Sugar.....	100		100	
Apple.....	100	0.0024	100	0.0024
Carrots.....	400	0.2080	533	0.2770
Total per day.....		0.2569		0.3209
“ “ kg.....		0.0054		0.0067

Digestive disturbances at the beginning and end of Period II (with carrots) in the case of R. S. E. show their effect in the negative calcium balance in both periods. It is worth noting, however, that on this low calcium intake distinct gains were made in three of the five periods and that if all the loss is charged to the carrot calcium the amount retained still represents 88 per cent of the intake.

In Series II, the allowance of calcium was practically the same as in the carrot diets of Series I. For lack of time, the milk period had to be omitted and the two young women who served as subjects subsisted for 12 days on a diet in which carrots furnished from 78 to 86 per cent of the total calcium. The daily diets are given in Table IV.

Slight changes in the diet were made after the first 4 days as E. H. found she could not eat so much carrot and E. W. that she could eat more. E. H. found the carrot diet sufficiently laxative

TABLE V.
Daily Intake and Output of Calcium. Series II.

Period.	Time.	Average daily intake of calcium.	Average daily output of calcium.			Calcium balance.
			Urine.	Feces.	Total.	
Subject E. H., weight 45.5 kg.						
	<i>days</i>	<i>gm.</i>	<i>gm.</i>	<i>gm.</i>	<i>gm.</i>	
I	4	0.282	0.058	0.198	0.256	+0.026
II	4	0.253	0.075	0.125	0.200	+0.053
III	4	0.249	0.081	0.217	0.298	-0.049
Average I-III.	12	0.261	0.071	0.180	0.251	+0.010
Subject E. W., weight 48 kg.						
I	4	0.257	0.083	0.166	0.249	+0.008
II	4	0.321	0.062	0.160	0.222	+0.099
III	4	0.321	0.050	0.130	0.180	+0.140
Average I-III.	12	0.300	0.065	0.152	0.217	+0.082

without the apple used for that purpose in Period I. The meat used was somewhat fatter and had a lower calcium content in the later periods. The daily intake and output for each subject are shown in Table V.

SUMMARY.

Two series of experiments to determine the utilization of the calcium of carrots by the human body have been carried out on four healthy young women. The calcium intake was in every case close to the estimated minimum for equilibrium.

Average Daily Intake and Output of Calcium.

Series.	Subject.	Diet.	Average daily intake of calcium.	Calcium.					
				From carrots.	Average daily output.			Balance.	Gain or loss.
					Urine.	Feces.	Total.		
			gm.	per cent	gm.	gm.	gm.	gm.	per cent
I	E. D. B.	Milk.	0.383		0.070	0.254	0.323	+0.060	+15.6
I	"	Carrot.	0.315	55	0.058	0.202	0.260	+0.055	+17.4
I	R. S. E.	Milk.	0.383		0.069	0.226	0.296	+0.087	+22.7
I	"	Carrot.	0.315	55	0.075	0.262	0.336	-0.023	- 7.3
II	E. H.	"	0.261	84	0.071	0.180	0.251	+0.010	+ 3.8
II	E. W.	"	0.300	86	0.065	0.152	0.217	+0.082	+26.6

In all cases but one there was a positive calcium balance on the carrot diet, and in this case the loss was small. When approximately 55 per cent of the calcium was derived from carrots, one subject had practically the same retention as on a diet in which 70 per cent of the calcium was derived from milk. It seems possible, therefore, to meet the requirement of the adult human organism for calcium largely, if not wholly, from carrots.

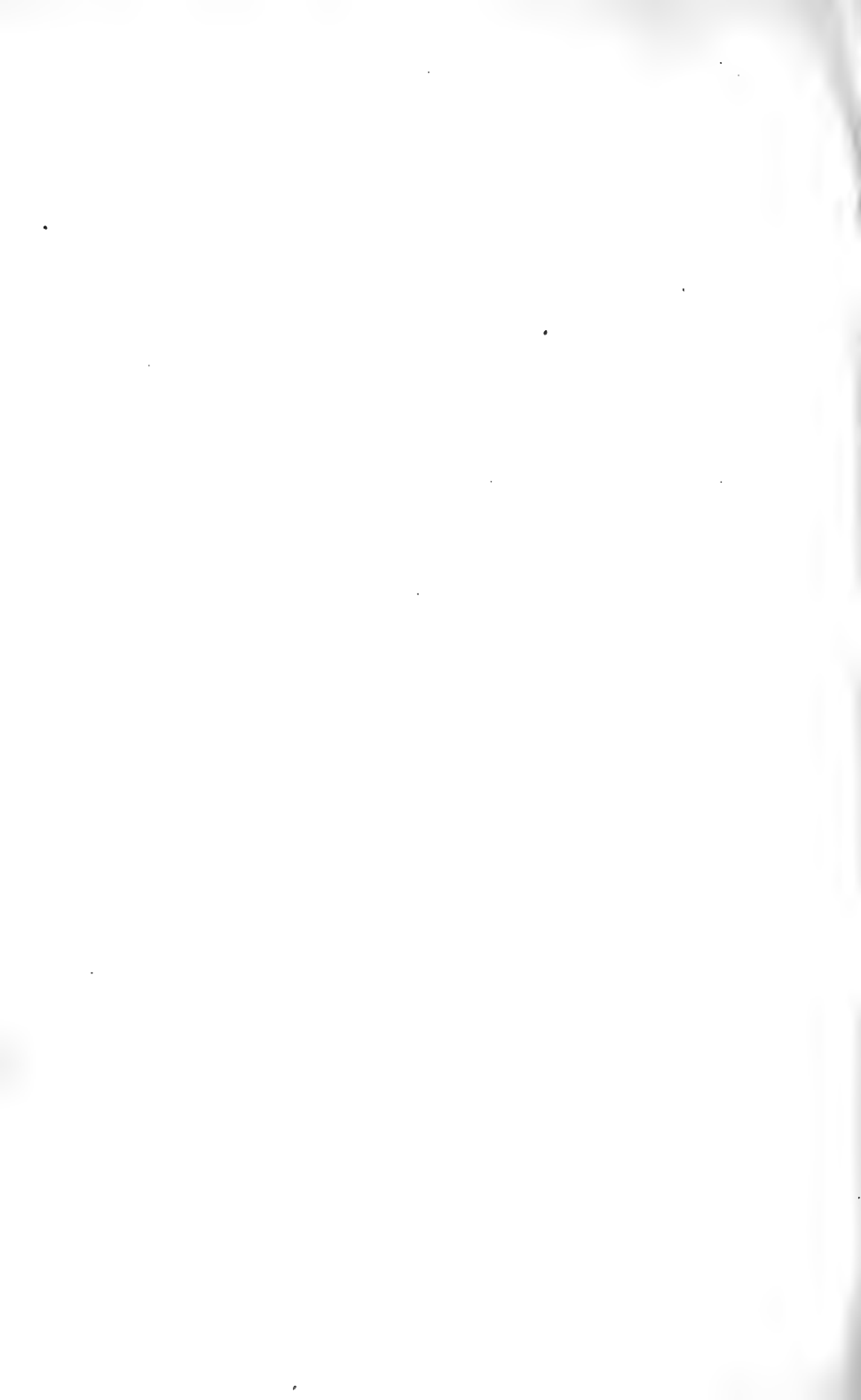

EFFECTS OF FEEDING WITH CALCIUM SALTS ON THE CALCIUM CONTENT OF THE BLOOD.

BY W. DENIS AND A. S. MINOT.

(From the Chemical Laboratory, Massachusetts General Hospital, Boston.)

(Received for publication, January 30, 1920.)

The advent of micro methods for the determination of blood calcium has opened up many interesting lines of work in a field hitherto practically closed on account of the relatively large amount of blood required for a single analysis, when the older gravimetric procedures are used. Somewhat more than a year ago there was begun in this laboratory a systematic study of the calcium content of the blood of persons suffering from a number of maladies for the relief of which calcium administration has been advocated, and of the effect on the blood calcium produced by the administration of calcium salts to these patients.

As a necessary preliminary to the interpretation of the results obtained on pathological material, we have carried out a number of experiments along the same lines on normal individuals and on animals, the results of which are described in the present paper. Our calcium determinations have been made by Lyman's (1) method, which has been modified in a few minor details.

All determinations have been made on citrated plasma (0.1 gm. of solid sodium citrate to 10 cc. of blood) as preliminary experiments convinced us that no calcium was precipitated by the use of this amount of sodium citrate, and that, as pointed out by Halverson, Möhler, and Bergeim (2), the determination of calcium in plasma or serum is of more significance than when made on whole blood, as originally recommended by Lyman.

In Table I we have collected the results obtained on five men and one woman, all normal subjects, who took by mouth daily three 2 gm. portions of calcium lactate, for a period of 6 to 10 days. During the period of calcium ingestion these subjects were under no regulations as regards food, but continued to eat their ordinary mixed diet.

As will be seen no effect on blood calcium was obtained by the daily ingestion of 6 gm. of calcium lactate in our normal human subjects. Attempts to give larger doses to men proved unsuccessful on account of the disagreeable taste of the various calcium salts tried, so that we were obliged to turn to animals for further experiments on the effects of relatively high calcium dosage.

As experimental subjects we have used cats and rabbits, as representing types of animals that ordinarily eat food differing widely in calcium content. These animals were kept in the

TABLE I.

Experimental Results Obtained on Feeding Calcium Lactate (6 Gm. per Day) to Normal Subjects.

Subject No.	Time.	Calcium per 100 cc. of plasma.
	<i>days</i>	<i>mg.</i>
1	1	7.6
	6	7.6
2	1	9.2
	6	9.1
3	1	11.0
	6	10.8
4	1	8.6
	6	9.2
5	1	11.8
	6	11.9
6	1	11.7
	10	11.8

laboratory and fed on the diet to be used during the experiment for 1 week before the initial samples of blood were taken. The food of the rabbits consisted of oats, cabbage, celery tops, and lettuce. The cats were given cooked lean meat (beef and mutton) in unmeasured amounts and in addition each cat received 50 cc. of milk per day.

In Table II we have collected the data obtained on seven cats to which calcium lactate was fed for periods varying from 15 to 38 days. While the number of experimental animals is rather

limited it would seem that it is sometimes possible by feeding with calcium salts to increase the calcium content of the blood of these animals, but that in certain instances calcium administration, even when continued for long periods, is without effect. There is apparently some relation between the initial calcium

TABLE II.

Experimental Results Obtained on Feeding Calcium Lactate to Cats.

Cat No.	Date.	Calcium per 100 cc. of plasma.	Remarks.
	<i>1919</i>	<i>mg.</i>	
1	Mar. 2	4.1	Male, weight 3,200 gm.; 0.5 gm. calcium lactate per day.
	" 27	7.3	
	June 11	5.2	2nd experimental period; 1.0 gm. calcium lactate per day.
	" 29	14.2	
2	Apr. 7	6.1	Female, weight 1,820 gm.; 0.5 gm. calcium lactate per day.
	" 27	7.2	
	June 11	7.6	2nd experimental period; 1.0 gm. calcium lactate per day.
	" 29	10.6	
3	Apr. 27	4.8	Male, weight 6,300 gm.; 0.5 gm. calcium lactate per day.
	May 12	5.7	
4	June 19	10.3	Female, weight 1,750 gm.; 0.5 gm. calcium lactate per day.
	" 29	10.4	
	July 11	11.4	2nd experimental period; 1.0 gm. calcium lactate per day.
	" 24	11.8	
5	Sept. 26	10.8	Male, weight 3,000 gm.; 1.0 gm. calcium lactate per day.
	Dec. 2	10.9	
6	Sept. 26	10.4	Male, weight 2,320 gm.; 1 gm. calcium lactate per day.
	Dec. 2	10.3	
7	July 26	11.0	Female, weight 1,950 gm.; 1.0 gm. calcium lactate per day.
	Dec. 2	11.4	

content of the plasma and the ease with which it is possible to effect changes in the blood by experimental means. Thus it will be noted that the calcium content of the plasma of Cats 1, 2, and 3 was rather low in the first sample, and that these animals responded positively to the administration of calcium salts,

whereas the plasma calcium of Cats 5, 6, and 7, for the species of animal, is rather high in initial value, and that calcium feeding was with them without demonstrable effect on the blood.

TABLE III.

Experimental Results Obtained on Feeding Calcium Lactate to Rabbits.

Rabbit No.	Date.	Calcium per 100 cc. of plasma.	Remarks.
	1919	mg.	
1	Feb. 16	11.2	Male, weight 2,100 gm.; 0.5 gm. calcium lactate per day.
	" 28	11.0	
18	July 24	13.5	Male, weight 1,800 gm.; 1.0 gm. calcium lactate per day.
	" 29	15.7	
4	Apr. 9	8.3	Female, weight 1,800 gm.; 0.5 gm. calcium lactate per day.
	" 27	8.2	
5	June 2	14.4	Female, weight 1,920 gm.; 1.0 gm. calcium lactate per day.
	" 11	14.2	
17	Sept. 25	14.4	Male, weight 2,240 gm.; 1.0 gm. calcium lactate per day.
	Dec. 1	14.3	
19	Sept. 25	16.0	Male, weight 2,100 gm.; 1.0 gm. calcium lactate per day.
	Dec. 1	15.8	
20	Sept. 25	8.2	Female; 5 young born 1 week before beginning of experiment; lactation continued for 4 weeks.
	Dec. 1	16.0	
21	Sept. 25	14.8	Female, weight 1,660 gm.; 1.0 gm. calcium lactate per day.
	Dec. 1	16.0	
22	Sept. 26	9.1	Female; on Oct. 6th delivered 6 young, which she nursed for about 4 weeks.
	Dec. 2	11.6	

The experimental results obtained on nine rabbits are summarized in Table III. As in the case of the cats but little effect on plasma calcium can be seen except in the case of Rabbits 20 and 22, both of which were lactating during a considerable portion of the experimental period, a fact which may account for the low initial values.

SUMMARY.

The result of a study of the effect of the administration of calcium salts by mouth to men, cats, and rabbits indicates that in most cases it is impossible to increase the concentration of calcium in the plasma by ingestion of calcium salts, but that in cats and rabbits where the initial concentration is low it is sometimes possible to greatly increase the amount of calcium in plasma by feeding salts of this element.

BIBLIOGRAPHY.

1. Lyman, H., *J. Biol. Chem.*, 1917, xxix, 169.
2. Halverson, J. O., Mohler, H. K., and Bergeim, O., *J. Biol. Chem.*, 1917, xxxii, 171.



DETERMINATION OF MAGNESIUM IN BLOOD.

BY W. DENIS.

(From the Chemical Laboratory, Massachusetts General Hospital, Boston.)

(Received for publication, January 30, 1920.)

In the course of an investigation of certain problems of calcium metabolism it became desirable to make determinations of magnesium in small amounts of plasma. The method described below has been worked out with this end in view, and has been adapted for use with the filtrate obtained after the precipitation of calcium in plasma or whole blood by Lyman's (1) method.

Briefly stated the procedure consists of the removal of organic material contained in the filtrate from the calcium determination, the precipitation of magnesium as magnesium ammonium phosphate, and the nephelometric determination of the phosphate in this compound by the reagent of Pouget and Chouchak (2). The detailed description of the method follows.

5 cc. of citrated plasma, serum, or whole blood are measured into 15 cc. of 6.5 per cent trichloroacetic acid solution, and after shaking the mixture is allowed to stand for at least 30 minutes, and is then filtered through a dry filter. 10 cc. of this filtrate (equivalent to 2:5 cc. of serum) are used for the determination of calcium according to the method of Lyman. In this method calcium is precipitated essentially according to the well known technique of McCrudden (3) and the crystals of calcium oxalate are then collected and washed by the help of the centrifuge. For the determination of magnesium the supernatant liquid remaining in the centrifuge tubes is collected by means of a small siphon, as is also the portion of ammonium oxalate solution used as wash liquid; the total amount of fluid collected in this way is placed in a flat-bottomed platinum dish and evaporated to dryness after the addition of 3 cc. of 10 per cent sulfuric acid; the residue in the dish is then ignited over a free flame until white, an operation which should be complete in 2 or 3 minutes. When cool the

white residue is dissolved in about 5 cc. of distilled water, and 10 per cent hydrochloric acid is added drop by drop until the solution of ash is acid to methyl orange. This solution is transferred quantitatively to a 100 cc. beaker, using distilled water to conclude the operation, and evaporated to a volume of 2 to 3 cc.; concentrated ammonium hydroxide is then added drop by drop until the solution is alkaline, and finally 0.5 cc. of 10 per cent ammonium phosphate solution containing 50 cc. of concentrated ammonium hydroxide per liter. The beaker is covered with a watch-glass and allowed to stand over night. The next day the liquid is poured into a conical centrifuge tube, and the beaker washed with 20 per cent alcohol containing 50 cc. of concentrated ammonium hydroxide per liter. After centrifuging, the liquid in the tube is removed by means of a small siphon, and the beaker and tube are again washed with about 10 cc. of the alcohol-ammonia mixture. Three more portions of wash liquid should be used, the precipitate being thoroughly stirred after each addition of fresh liquid.

The precipitation and subsequent washing just described are essentially the process described by Marriott and Howland (4) in their micro method for the determination of magnesium in blood.

This portion of the procedure is at once the most important and the most unsatisfactory feature of the determination. Both in the method of Marriott and Howland and in the procedure described in this paper, recourse has of necessity been had to a principle which every chemist will recognize as theoretically incorrect; *viz.*, the determination of magnesium by the measurement of the phosphate combined as ammonium magnesium phosphate, the precipitation of which latter compound must be carried on in the presence of a large excess of phosphate. It is obvious that extremely careful work is essential in the washing of the precipitate in order to avoid contamination with residual traces of ammonium phosphate; furthermore as is well known, it is possible to overwash an ammonium magnesium phosphate precipitate, so that low results are obtained.

After the removal of the last portion of wash liquid, the tube and beaker are allowed to stand, preferably on a water bath or register until the ammonium has evaporated, and the ammonium magnesium phosphate is then dissolved in 10 cc. of 0.1 *N* hydrochloric acid and transferred to a 100 cc. volumetric flask by means of distilled water. The solution is then made to volume with

distilled water, mixed, and the phosphate determined by means of the strychnine molybdate reagent.¹

For the determination of magnesium in normal plasma or serum 25 cc. of the above solution are usually the most convenient to use, but larger or smaller amounts are sometimes called for.

To the amount of solution taken is added a quantity of distilled water sufficient to bring the volume to 50 cc., then 25 cc. of the strychnine molybdate reagent are added. After standing for a period of 5 minutes the suspension is read against a standard containing 0.01 mg. of magnesium in a volume of 50 cc.² to which have been added 25 cc. of the strychnine molybdate reagent, and which has been allowed to stand for the same length of time as the unknown.

The procedure as outlined above has been carried out in pure solutions containing 0.02 to 0.10 mg. of magnesium, and on similar amounts of magnesium added to serum and plasma. The average recovery in these experiments has been 94 per cent.

The magnesium in more than 100 determinations made on human blood serum (many of which were on pathological cases) has given figures varying from 0.8 to 3.8 mg. per 100 cc. of plasma. In the more strictly normal material, values from 1.6 to 3.5 mg. have been obtained.

BIBLIOGRAPHY.

1. Lyman, H., *J. Biol. Chem.*, 1917, xxix, 169.
2. Pouget, I., and Chouchak, D., *Bull. Soc. Chim.*, 1909, v, 104.
3. McCrudden, F. H., *J. Biol. Chem.*, 1911-12, x, 187.
4. Marriott, W. McK., and Howland, J., *J. Biol. Chem.*, 1917, xxxii, 233.
5. Bloor W. R., *J. Biol. Chem.*, 1918, xxxii, 34.

¹ For this reagent the modification described by Bloor (5) gives most satisfactory results.

² This standard is prepared from ammonium magnesium phosphate by dissolving 1.02 gm. of the pure salt in 100 cc. of N hydrochloric acid and diluting to a volume of 1 liter with distilled water; 1 cc. of this solution is equivalent to 0.10 mg. of magnesium. For the preparation of this dilute standard a portion of the strong solution is diluted 50 times with 0.1 N hydrochloric acid so that 5 cc. of the resulting solution will be equivalent to 0.01 mg. of magnesium.



A SYSTEM OF BLOOD ANALYSIS.

SUPPLEMENT I.

A SIMPLIFIED AND IMPROVED METHOD FOR DETERMINATION OF SUGAR.

BY OTTO FOLIN AND HSIEN WU.

(From the Biochemical Laboratory, Harvard Medical School, Boston.)

(Received for publication, January 26, 1920.)

In our system of blood analysis published a short time ago¹ we described a new method for the determination of sugar. In this method the sugar is oxidized by a weakly alkaline copper tartrate solution and the cuprous copper formed is estimated colorimetrically by the help of the phenol reagent of Folin and Denis. In this determination the errors due to creatine, creatinine, and uric acid are eliminated while a new source of error, namely that due to the so called phenols, is introduced. This last named error is certainly much smaller than the errors due to creatine, creatinine, and uric acid in other methods, so that in point of accuracy our method should be fully as good as any other known method. We could have eliminated any error due to the so called phenols by simply omitting the addition of sodium carbonate, because the phenol reagent reacts with cuprous copper in acid solution. Incidentally we should thus also eliminate the blank due to the alkaline copper tartrate. The process so obtained seemed to us less satisfactory, however, for the reason that the phenol reagent has a pronounced yellow color.² The matching of the colors in the colorimeter is rendered difficult and uncertain under such conditions, and would not be accurate except when the standard and the unknown are nearly of the same

¹ Folin, O., and Wu, H., *J. Biol. Chem.*, 1919, xxxviii, 106.

² The phenol reagent sometimes has a greenish color due to some reduction by organic dusts.

strength. We accordingly chose to destroy the surplus phenol reagent by the addition of sodium carbonate.

In the course of subsequent studies of the method we have found a process by which the disturbing effects of the phenols can be eliminated. To accomplish this purpose we have replaced the regular phenol reagent of Folin and Denis by a reagent which reacts with cuprous copper, in acid solution, yet gives no color with phenols. This new reagent is prepared as follows:

Transfer to a liter beaker 35 gm. of molybdic acid and 5 gm. of sodium tungstate. Add 200 cc. of 10 per cent sodium hydroxide and 200 cc. of water. Boil vigorously for 20 to 40 minutes so as to remove nearly the whole of the ammonia present in the molybdic acid.³ Cool, dilute to about 350 cc., and add 125 cc. of concentrated (85 per cent) phosphoric acid. Dilute to 500 cc.

It will be seen that the preparation of this reagent is much simpler than the preparation of the phenol reagent. The solution has none of the yellow color of the phenol reagent, yet gives an intense blue color with cuprous oxide. Since the reaction takes place in acid solution the blue color of the alkaline copper tartrate is also eliminated. The sodium tungstate contained in this reagent is added because there is sodium tungstate in our blood filtrates, and tungstates modify somewhat the shade of blue obtained in the reaction.

The alkaline copper solution has not been changed. Dissolve 40 gm. of pure anhydrous sodium carbonate in about 400 cc. of water and transfer to a liter flask. Add 7.5 gm. of tartaric acid, and when the latter has dissolved add 4.5 gm. of crystallized copper sulfate. Mix and make up to a volume of 1 liter. If the chemicals used are not pure a sediment of cuprous oxide may form in the course of 1 or 2 weeks. If this should happen, remove the clear supernatant reagent with a siphon, or filter through a good quality filter paper. Our reagent seems to keep indefinitely. To test for the absence of cuprous copper in the solution, transfer 2 cc. to a test-tube and add 2 cc. of the molybdate phosphate solution; the deep blue color of the copper should almost completely vanish. In order to forestall improper use of this reagent attention should be called to the fact that it contains

³The molybdic acid we used was obtained from the Primos Company, Primos, Pa., and it contained considerable ammonia.

extremely little alkali, 2 cc. by titration (using the fading of the blue copper tartrate color as indicator), requiring only about 1.4 cc. of normal acid.

Standard Sugar Solutions.—Three standard sugar solutions should be on hand: (1) a stock solution, 1 per cent dextrose or invert sugar, preserved with xylene or toluene; (2) a solution containing 1 mg. of sugar per 10 cc. (5 cc. of the stock solution diluted to 500 cc.); (3) a solution containing 2 mg. of sugar per 10 cc. (5 cc. of the stock solution diluted to 250 cc.). The invert sugar solution has the advantage that it can be easily prepared from cane sugar, which is pure. The keeping quality of such solutions should be less good than those made from glucose, but we have encountered no trouble on that score. When good quality glucose is available, it is, of course, the one to use. The diluted solutions should be preserved with a little added toluene or xylene; it is probably better not to depend on such diluted solutions to keep for more than a month, but the stock solution should keep indefinitely.

It is a well known fact that the cuprous compounds produced by sugar in alkaline copper solutions show a marked tendency to be reoxidized to the cupric condition when exposed to air. Most of us are all too familiar with that fact in connection with ordinary sugar titrations done by overcautious students. That such reoxidation must occur to some extent in our colorimetric blood sugar determination is also undeniable. Without having made any direct experiments on the extent of such reoxidations we had satisfied ourselves that they do not contribute any material error in our sugar determinations. Check experiments with sugar solutions 50 per cent apart and heated 4, 6, and 8 minutes had given proportionate values. And in actual blood sugar determinations the values obtained were not changed by varying the heating time from 4 to 8 minutes. We had therefore no occasion to fear that material analytical errors could creep in because of the reoxidation.

At the last annual meeting of the American Association of Biological Chemists (Cincinnati, 1919), Benedict condemned our blood sugar method on the ground of excessive, inevitable, and uncontrollable reoxidations of cuprous oxide. He cited shaking experiments by means of which more than 60 per cent were made

to disappear. He also asserted that reoxidations are much more extensive in blood filtrates than in pure sugar solutions and therefore insisted that the blood sugar values obtained by our method must be too low. Vigorous shaking, as it happens, is also disastrous to the reaction between reducing sugar and alkaline picrates. Losses of 40 per cent can be secured by shaking (in 25 cc. flasks), and if agitation by an air current is substituted for shaking, nearly the whole of the sugar represented in a blood sugar determination by Benedict's method is lost. We cite these observations not as a criticism of Benedict's method but merely to show the grossly misleading character of shaking experiments.

It must be admitted nevertheless that we made something of an error in depending exclusively on indirect evidence on so important a point as the losses of cuprous oxide, and we gladly give Benedict credit for having compelled us to reexamine our method with reference to the effect of reoxidation. We have verified our earlier findings that analytical errors do not occur because of such reoxidation, but this is because all our test-tubes in which the oxidation of sugar takes place are of substantially the same diameter, 17 to 18 mm. on the inside. The oxidation in such tubes, when kept in a somewhat slanting position, may amount to as much as 20 per cent of the cuprous oxide formed, yet correct sugar values are obtained.

In order to get data on the reoxidation problem we have conducted the reduction in test-tubes of different internal diameters ranging from 4 to 23 mm. With test-tubes in a vertical position there is practically no loss of cuprous oxide by reoxidation until the diameter of the tube is at least 15 mm. At about 20 mm. or above the losses become astoundingly large. Currents having a somewhat similar effect as shaking must come into play in such tubes for the losses are not at all proportionate to the areas of the surface of solution. Shaking was of course excluded. The results of two series of experiments of the kind indicated are shown in Table I.

The remarkable fact about these reoxidations is that the percentage loss of copper so produced is not materially dependent on the amount of cuprous oxide involved. In a given tube the percentage loss is substantially the same whether one works with 0.1 or 0.4 mg. of sugar, whether with pure sugar solution or our blood

filtrate, and this is manifestly the reason why our original method has given uniformly concordant values. The results recorded in Table II show that the per cent loss of copper is almost independent of the amount of reduction involved. The reductions were made simultaneously in test-tubes of definite but widely different internal diameters.

TABLE I.

Relation Between Area of Surface of Solution and Loss of Cuprous Oxide by Reoxidation, Using 0.1 Mg. of Sugar.

Internal diameter of tube at level of surface of solution.	Colorimeter reading.	Loss.
<i>mm.</i>		<i>per cent</i>
4*	19.8	0
6	20	0
9	20	0 (?)
11	20	0 (?)
14	20, 20.5	0, 3
16	21.4, 22.5	7, 13
19	27.5, 29.5	27, 32
23	31, 32	36, 36

* In hydrogen atmosphere.

TABLE II.

Showing that Percentage Loss of Cuprous Oxide by Reoxidation Is not Materially Affected by Amount of Sugar Used for Reduction.

Amount of sugar used.	Colorimeter readings.		
	Constricted tube, 4 mm.	Open tube, 16 mm.	Open tube, 20 mm.
<i>mg.</i>			
0.1	20	22	28
0.2	20	21.8	
0.4	20	22	26
0.8	10	11	

In view of these findings it is necessary to be more precise than we had been in our description of the kind of test-tubes to be used. We prescribed test-tubes having the dimensions 200 × 20 mm. because ours were bought under those specifications, whereas in point of fact their internal diameter is only 17 to 18 mm. The subject is of sufficient importance to call for a special

tube by the use of which reoxidation is automatically excluded. This special blood sugar test-tube is shown in Fig. 1. The essential point to be observed in connection with it is, of course, that the surface of the alkaline mixture of sugar and copper shall reach the constricted part.

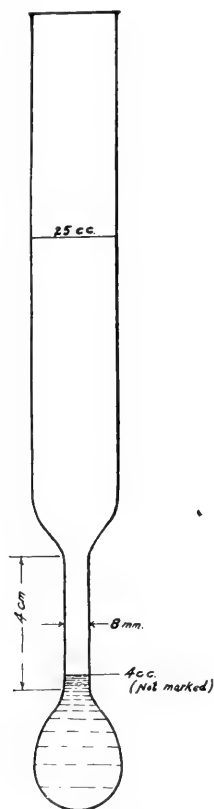

FIG. 1. Blood sugar tube.

Test-tubes of this sort, with and without graduation, are now made by The Emil Greiner Company, 55 Fulton Street, New York, and can also be obtained from Arthur H. Thomas Company, West Washington Square, Philadelphia. For the benefit of those who wish to make and graduate their own test-tubes we

suggest that a stem of about the size of a cherry stem should first be attached to the bottom of the test-tube. This stem is best produced by sealing on a piece of a broken test-tube and then drawing it out. If a good blast lamp is available, the whole process of making a tube does not take more than 2 or 3 minutes.

The blood sugar determination is now made as follows:

Transfer 2 cc. of the tungstic acid blood filtrate to a blood sugar test-tube, and to two other similar test-tubes (graduated at 25 cc.) add 2 cc. of standard sugar solution containing respectively 0.2 and 0.4 mg. of dextrose. To each tube add 2 cc. of the alkaline copper solution. The surface of the mixtures must now have reached the constricted part of the tube. If the bulb of the tube is too large for the volume (4 cc.) a little, but not more than 0.5 cc., of a diluted (1 : 1) alkaline copper solution may be added. If this does not suffice to bring the contents to the narrow part, the tube should be discarded. Test-tubes having so small a capacity that 4 cc. fills them above the neck should also be discarded. Transfer the tubes to a boiling water bath and heat for 6 minutes. Then transfer them to a cold water bath and let cool, without shaking, for 2 to 3 minutes. Add to each test-tube 2 cc. of the molybdate phosphate solution. The cuprous oxide dissolves rather slowly if the amount is large but the whole, up to the amount given by 0.8 mg. of dextrose, dissolves usually within 2 minutes. When the cuprous oxide is dissolved, dilute the resulting blue solutions to the 25 cc. mark, insert a rubber stopper, and mix. It is essential that adequate attention be given to this mixing because the greater part of the blue color is formed in the bulb of the tube.

The two standards given representing 0.2 and 0.4 mg. of glucose are adequate for practically all cases. They cover the range from about 70 to nearly 400 mg. of glucose per 100 cc. of blood.

It will be noted that in the process described we prescribe cooling of the alkaline cuprous oxide suspension before adding the phosphate molybdate solution. This cooling is not essential and, in case of one or two determinations only, may be omitted. In a large series of determinations it is probably best to use it. The important point is that the standard and the unknowns should not only be heated the same length of time but should also have

substantially the same temperature when the acid reagent is added. The maximum color develops faster in hot solutions; but if a reasonable uniformity of condition is maintained it makes no difference whether the color comparison is made at the end of 5 minutes or at the end of 1 hour.

TABLE III.

Comparison of Blood Sugar Values per 100 Cc. Obtained by Original and Revised Methods.

Source.	Revised method.	Original method.	
		Open tube.	Constricted tube.
	<i>mg.</i>	<i>mg.</i>	<i>mg.</i>
1* Human.	30	34	
2 "	61	65	
3 "	90	91	
4 "	99	93	
5 "	105	108	
6 "	90	98	
7 "	105	121	
8 "	121	129	125
9 "	134	130	130
10 "	131	131	131
11 "	200	210.	218
12 "	224	218	228
13 Dog.	86	85	
14 "	84	85	

* Blood 24 hours old.

In our blood sugar method as we now have it reoxidations of the cuprous compounds are excluded; the blank due to the blue alkaline copper tartrate is eliminated, and, finally, the error due to the so called phenols in blood filtrates is removed. From a theoretical standpoint the method now appears to be without a flaw, and from the experimental standpoint it is rather more simple, inasmuch as the addition of sodium carbonate is omitted. The analytical figures in Table III show that the new process tends to give slightly lower values than the original method.

DISTRIBUTION OF THE BASIC NITROGEN IN PHASEOLIN.

BY A. J. FINKS AND CARL O. JOHNS.

(From the Protein Investigation Laboratory, Bureau of Chemistry, United States Department of Agriculture, Washington.)

(Received for publication, January 14, 1920.)

Determination of the hydrolytic products of phaseolin, the chief protein of the navy bean, *Phaseolus vulgaris*, has been made by Osborne and Clapp (1). They did not find the amino-acid content essentially different from other vegetable globulins. It contained a sufficient quantity of the amino-acids known to be necessary for normal growth, with the possible exception of cystine. Nutrition experiments, however, by Osborne and Mendel (2), and McCollum, Simmonds, and Pitz (3) with the proteins of this bean met with little success.

TABLE I.
Basic Amino-Acids in Phaseolin.

Amino-acid.	Van Slyke method.	Absolute method, Osborne and Clapp (1).
	<i>per cent</i>	<i>per cent</i>
Cystine	0.84	Not determined.
Arginine	6.11	4.87
Histidine	3.32	2.62
Lysine	7.88	4.58

To obtain more information for use in our nutrition experiments with the navy bean, an analysis of phaseolin by the Van Slyke (4) method was made. It will be noted that the results found by this method for the basic amino-acids were higher than those obtained by the direct method of Kossel and Patten (5), the value obtained for lysine being considerably greater. Sulfur determinations on the basic amino-acid fraction indicated the presence of 0.84 per cent of cystine. The accuracy of this method for the determination of cystine is uncertain particularly in cases where the per-

centage of sulfur in proteins is low, since a comparatively large correction has to be applied for the solubility of cystine phosphotungstate. The results of our analysis together with those obtained by Osborne and Clapp are summarized in Table I.

EXPERIMENTAL.

Analysis of Phaseolin by the Van Slyke Method.—Duplicate 3 gm. samples of phaseolin were used, each equivalent to 2.8476 gm. of moisture and ash-free protein and containing 15.99 per

TABLE II.

Analysis of Phaseolin by Van Slyke Method. Nitrogen Corrected for Solubility of Bases.

	I	II	I	II	Average.
	gm.	gm.	per cent	per cent	per cent
Amide N.....	0.0496	0.0495	10.90	10.88	10.89
Humin N adsorbed by lime..	0.0079	0.0077	1.73	1.70	1.72
“ N in amyl alcohol extract.....	0.0008	0.0020	0.17	0.45	0.31
Cystine N.....	0.0027	0.0029	0.59	0.64	0.61
Arginine N.....	0.0545	0.0576	11.97	12.65	12.31
Histidine N.....	0.0260	0.0252	5.71	5.53	5.62
Lysine N.....	0.0427	0.0437	9.38	9.60	9.49
Amino N of filtrate.....	0.2470	0.2533	54.25	55.63	54.94
Non-amino N of filtrate.....	0.0209	0.0146	4.59	3.21	3.90
Total N regained.....	0.4521	0.4565	99.29	100.29	99.79

TABLE III.

Basic Amino-Acids in Phaseolin.

Amino-acid.	I	II	Average.
	per cent	per cent	per cent
Cystine.....	0.81	0.87	0.84
Arginine.....	5.94	6.28	6.11
Histidine.....	3.37	3.27	3.32
Lysine.....	7.79	7.97	7.88

cent or 0.1553 gm. of nitrogen. Each sample was hydrolyzed for 24 hours by boiling with 100 cc. of 20 per cent hydrochloric acid. The phosphotungstates of the bases were decomposed by the

amyl alcohol-ether method (6). The results of these analyses are recorded in Tables II and III.

SUMMARY.

1. The basic amino-acids of phaseolin were determined by the Van Slyke method of analysis.
2. The percentage of lysine was found to be considerably higher than that obtained by the direct method of Kossel and Patten.

BIBLIOGRAPHY.

1. Osborne, T. B., and Clapp, S. H., *Am. J. Physiol.*, 1907, xviii, 295.
2. Osborne, T. B., and Mendel, L. B., *Z. physiol. Chem.*, 1912, lxxx, 307.
3. McCollum, E. V., Simmonds, N., and Pitz, W., *J. Biol. Chem.*, 1917, xxix, 521.
4. Van Slyke, D. D., *J. Biol. Chem.*, 1911-12, x, 15.
5. Kossel, A., and Patten, A. J., *Z. physiol. Chem.*, 1903, xxxviii, 39.
6. Van Slyke, D. D., *J. Biol. Chem.*, 1915, xxii, 281.



STUDIES IN NUTRITION.*

II. THE RÔLE OF CYSTINE IN NUTRITION AS EXEMPLIFIED BY NUTRITION EXPERIMENTS WITH THE PROTEINS OF THE NAVY BEAN, PHASEOLUS VULGARIS.

BY CARL O. JOHNS AND A. J. FINKS.

(From the Protein Investigation Laboratory, Bureau of Chemistry, United States Department of Agriculture, Washington.)

(Received for publication, January 14, 1920.)

A great advance was made in our knowledge of the principles of nutrition when it was shown that the nutritive value of proteins depends on the relative proportions of certain amino-acids in the protein molecule. Numerous experiments have demonstrated that the withdrawal or addition of certain amino-acids renders diets deficient or makes them complete for normal growth. It is well known that proteins which lack either lysine or tryptophane fail to promote the growth of animals. It has also been established that certain other amino-acids are necessary for maintenance and growth and that some of the amino-acids usually found in proteins are not essential.

Thus, Ackroyd and Hopkins (1) have shown that arginine and histidine are to some extent interchangeable. Totani (2) does not regard tyrosine as an essential amino-acid and suggests the possibility that phenylalanine may take its place in nutrition. Hopkins (3) has also shown that when both glutaminic and aspartic acids were removed from the products of hydrolysis of a biologically complete protein the resulting amino-acid residue was still adequate for normal growth. The theory that the nutritive value of a protein depends upon its amino-acid content encountered an apparent contradiction in the fact that phaseolin from the navy bean failed to promote growth, although it had been shown by Osborne and Clapp (4) that this protein contains all the known essential amino-acids.

* Read before The National Academy of Sciences, New Haven, 1919.

The nutritive value of phaseolin has been studied by Osborne and Mendel (5) who used the isolated protein in their experiments. The animals failed to grow and died in a relatively short time. McCollum, Simmonds, and Pitz (6) fed navy bean meal as the sole source of protein in the diet and their experiments also resulted in a failure to obtain growth. These authors attribute the failure of the navy bean to promote growth to the presence of hemicelluloses.

In our experiments where navy bean meal was used as the sole source of protein we could not detect any symptoms of tymanites although the animals failed to grow.

In making a study of the chemical analysis of phaseolin published by Osborne and Clapp (4) it seemed that all the known essential amino-acids were present in sufficient quantities to promote growth with the possible exception of cystine. An analysis of phaseolin (7) made by Van Slyke's method did not throw any further light on the subject and gave higher results for the basic amino-acids than those reported by Osborne and Clapp. This still left the question of a possible deficiency of cystine. It was evident that the percentage of cystine in phaseolin cannot be very high since this protein contains but approximately 0.3 per cent of sulfur. If all this belonged to cystine there would be only about 1.2 per cent of this amino-acid in phaseolin. It is probable, however, that only about one-third of the total sulfur in phaseolin represents cystine, as shown by Osborne (8) who determined the percentage of total sulfur liberated when a number of different proteins were boiled with potassium hydroxide. It was assumed that approximately two-thirds of the cystine sulfur of proteins was thus liberated as hydrogen sulfide. This assumption was based on experiments with pure cystine from which approximately two-thirds of the total sulfur was liberated as hydrogen sulfide when treated in the same manner. It is not known in what form the non-cystine sulfur exists in proteins.

In view of the above facts it appeared that the failure of phaseolin to promote growth might be due to a deficiency in cystine. 2 per cent of cystine, prepared from wool, was therefore added to the phaseolin and 18 to 20 per cent of this mixture was used in a diet together with the essential non-protein ingredients. The animals placed on this diet maintained their weight for a con-

siderable time and grew slightly but the results were far from satisfactory. While the addition of cystine had improved the nutritive value of phaseolin the failure to obtain normal growth was still an unsolved problem.

The question of the digestibility of phaseolin was next considered, since metabolism experiments (9, 10) had shown that the nitrogen of the navy bean was not well assimilated. Phaseolin was therefore subjected to digestion with trypsin *in vitro*. The usual procedure was followed, the mixture being made slightly alkaline with sodium carbonate and the digestion carried out at 37°C. To prevent bacterial growth, the phaseolin was heated at 100°C. in air and 0.1 per cent of sodium benzoate was added to the distilled water used in the digestion. When incubation was complete the sodium carbonate was neutralized with hydrochloric acid and the solution evaporated to dryness on a steam bath. The residue was ground to a powder and 2 per cent of cystine was added. When this digested phaseolin, supplemented with cystine, was used as the sole source of protein in the diet, the rats grew normally. There were then several factors to consider. Was the success obtained due to the digestion with trypsin, or the alkaline action of the sodium carbonate, or the heating during the evaporation? It seemed improbable that the sodium benzoate was one of the factors, other than aiding in maintaining sterility. Bacterial counts¹ were made before and after incubation by making cultures on agar. The bacterial content was so low that fermentation from this source was eliminated as a factor. Experiments were made in which the trypsin, sodium carbonate, and sodium benzoate were eliminated one by one, and normal growth was still obtained when the phaseolin was simply suspended in water, boiled for 30 minutes, and the mixture evaporated to dryness, 2 per cent of cystine being added to the residue before preparing the diet. A ration containing phaseolin which had been heated with water, but to which no cystine had been added, was also tried and slow growth was obtained. When cystine was added to this ration the rate of growth became normal. The success of the experiments, therefore, depended on two factors. *Phaseolin is rendered a more efficient food by heating it with water. It must also be supplemented by cystine to obtain normal growth.*

¹ The bacterial counts were made by Miss R. B. Edmondson of the Microbiological Laboratory, Bureau of Chemistry.

It is difficult to explain why heating phaseolin with water renders it more nutritious. This process may cause some molecular rearrangement to occur in the very complex and probably labile protein molecule, thereby making it more readily digestible or the phaseolin may possess a slight toxicity which is destroyed by heating with water.

It now seemed important to ascertain whether or not navy bean meal could be rendered efficient for normal growth by the process mentioned above. The cooked meal had been tried in our earlier experiments but while the rats maintained their weight for a considerable time only slight growth was obtained. The bean meal yielded to treatment in the same manner as phaseolin. When cooked, dried, and supplemented with cystine, it produced normal growth when used as the sole source of protein in the diet.

The importance of cystine as an ingredient of a complete diet has been shown by a number of investigators. Osborne and Mendel (11) have shown that, when casein is supplemented with cystine, 9 per cent of the casein is as effective as 15 per cent of casein alone. This percentage they found to be necessary for normal growth in diets of high calorific value.

Aberhalden (12) conducted nutrition experiments with hydrolyzed proteins from which he had attempted to remove the cystine. He did not reach any definite conclusion, although he states that cystine is apparently necessary. Hopkins and his coworkers (1, 2, 3), in their nutrition experiments with hydrolyzed proteins, always added cystine, since this amino-acid is partly decomposed by heating with acids during the process of hydrolysis. Mitchell (13) and Geiling (14) also added cystine to the diets used in their experiments with white mice when feeding amino-acid mixtures. Lewis (15), experimenting on dogs, showed that if small quantities of cystine were added to diets low in protein the nitrogen elimination of the animals diminished, whereas an equivalent quantity of nitrogen in the form of tyrosine or glycine added to the diet did not diminish the quantity of nitrogen eliminated. It is evident that Lewis was experimenting with diets in which cystine was a limiting factor. Daniels and Rich (16) attempted to substitute inorganic sulfates for cystine but without success.

Casein contains 0.8 per cent of sulfur but Osborne (8) has shown that approximately only 0.15 per cent of the casein is cystine sul-

fur. McCollum, Simmonds, and Pitz (6) found that casein was not a very effective supplement to navy bean proteins. Their observation is now readily interpreted when it is considered that they were supplementing the navy bean protein, which is low in cystine, with casein which also is low in cystine. It seems probable that cystine was the limiting factor in this mixture of proteins. These facts lend a new interest to the experiments of Osborne (8) in which he attempted to ascertain the proportion of cystine sulfur to the total sulfur in a number of proteins. The proteins were boiled with potassium hydroxide and the sulfur liberated as hydrogen sulfide was multiplied by three-halves to obtain the quantity of cystine sulfur in the proteins. The results indicated that the sulfur in the form of cystine varied from approximately 20 to 75 per cent of the total sulfur in the fifteen vegetable and animal proteins examined (17). He noted that casein and phaseolin, which become more efficient when supplemented with cystine, both yield but small quantities of hydrogen sulfide when boiled with alkali. On the other hand such proteins as ovalbumin, fibrin, ovovitellin, and edestin, which are known to be efficient proteins, yield a relatively large quantity of hydrogen sulfide.

The work herein described was reported in a preliminary paper read before the Society of Biological Chemists at the Baltimore meeting in April, 1919. At that time Osborne and Mendel informed us that they had conducted further experiments on the nutritive value of phaseolin but the results of this work had not been published. They also found that the nutritive value of phaseolin was increased by cooking. Furthermore, they found that the protein extracted from the navy bean by sodium hydroxide and reprecipitated by neutralization was more effective than phaseolin prepared by extraction with sodium chloride and precipitated by dialysis. Osborne and Mendel very kindly placed the results of their unpublished work at our disposal and some of the curves shown in this paper are taken from their experiments.

Experiments with Raw and Cooked Phaseolin.—This work was done by Osborne and Mendel who found that when raw phaseolin was the sole source of protein in an otherwise adequate diet the rats declined in weight rapidly and some of them died. When the phaseolin was replaced by casein the growth became normal. By alternating phaseolin with casein in the diet the rats could be

made to lose weight or grow normally. Phaseolin which had been cooked for a short time in water served to maintain weight but produced practically no growth. In all these experiments the water-soluble vitamins and salts were supplied by protein-free milk and the fat-soluble vitamins by butter fat. The curves are shown in Chart 1.

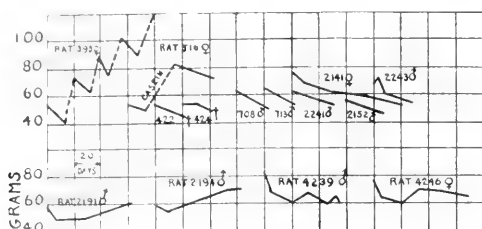

CHART 1. The upper set of curves shows the failure of raw phaseolin to maintain the weight of white rats. In the curves for Rat 393 ♀ and Rat 516 ♀ the solid lines of the curves show the effects of a diet in which phaseolin was the sole source of protein. The broken portions of the curves show the effect of replacing the phaseolin with casein. The daggers indicate that the rats died.

The lower set of curves shows the effect of cooking the phaseolin before preparing the diet. It will be seen that the rats were almost able to maintain their weights for a considerable time but could not grow. The phaseolin was stirred into distilled water and cooked for 5 minutes after the water had been heated to the boiling point. It was then filtered off and dried. The curves in this chart represent the results of unpublished experiments by Osborne and Mendel. The composition of the diets follows.

	Uncooked. gm.	Cooked. gm.
Phaseolin (or casein).....	18	18
Protein-free milk.....	28	28
Starch.....	28	28
Butter fat.....		18
Lard.....	26	8
	100	100

Experiments with Phaseolin Supplemented with Cystine.—The raw phaseolin² used in these experiments was supplemented with 2

² The phaseolin and cystine used in these experiments were prepared by Mr. C. E. F. Gersdorff of the Protein Investigation Laboratory, Bureau of Chemistry.

per cent of cystine and this mixture was used as the sole source of protein in an otherwise adequate diet. The addition of cystine to the raw phaseolin enabled the rats to grow slowly. A mixture of cooked phaseolin supplemented with cystine at once improved the growth. The replacement of the raw phaseolin supplemented with cystine by casein after the rats had grown but very little for some time also caused a marked improvement in the rate of growth. The results of these experiments are shown in Chart 2.

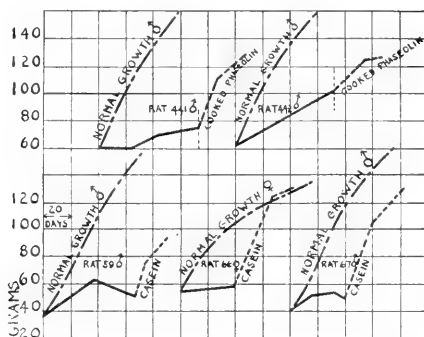

CHART 2. The upper set of curves shows that raw phaseolin supplemented with cystine enabled the rats to grow slowly. During the period indicated by the dotted portion of these curves the rats received cooked phaseolin supplemented with cystine. A marked improvement in the rate of growth occurred at once when the raw phaseolin was replaced by the cooked protein.

In the experiments represented by the lower set of curves the rats received raw phaseolin supplemented with cystine. During the second period, shown by the broken lines, the animals received casein instead of the phaseolin and cystine.

The composition of the diet follows.

	<i>gm.</i>
Phaseolin.....	17.64
Cystine.....	0.36
Protein-free milk.....	28.00
Starch.....	21.00
Agar.....	5.00
Butter fat.....	18.00
Lard.....	10.00
	100.00

Experiments with Cooked Phaseolin Supplemented with Cystine.—A number of experiments were made with phaseolin cooked under various conditions and supplemented with cystine. In some cases the phaseolin was predigested with trypsin and cooked before adding cystine. Some of the diets contained sodium benzoate which had been used to keep the solution sterile during digestion with trypsin. In all cases the rats grew at a normal rate when the phaseolin was cooked, whether or not it had been predigested, if finally supplemented with cystine. In two experiments the animals received cooked phaseolin for some time without the addition of cystine. The rate of growth was far below normal but became normal when cystine was added to the diet. The results of these experiments are shown in Chart 3.

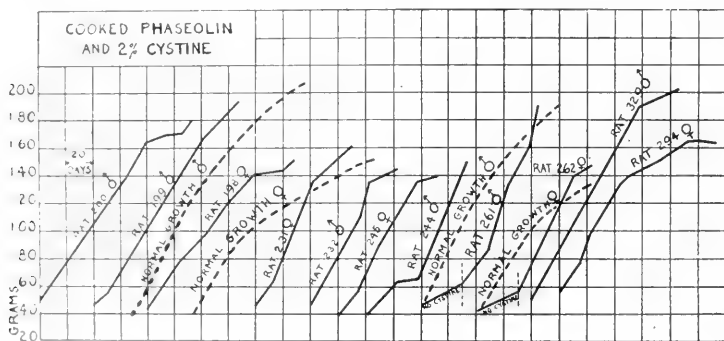

CHART 3. The curves in this chart show that normal growth was obtained on diets containing cooked phaseolin supplemented with cystine. The protein given to Rats 198 ♀, 199 ♂, and 200 ♂ was treated by suspending 12.5 gm. of phaseolin in distilled water to each 100 cc. of which had been added 0.5 gm. of sodium carbonate, 0.1 gm. of sodium benzoate, and 0.05 gm. of trypsin. This mixture was incubated for 5 hours at 37°C., heated to boiling, neutralized with hydrochloric acid, and evaporated to dryness on a steam bath. The residue was ground to a powder and mixed with 2 per cent of cystine. The phaseolin fed to Rats 231 ♀ and 232 ♂ was treated in the same manner but the trypsin was omitted. The phaseolin given to Rats 244 ♂ and 245 ♀ received similar treatment but without the addition of sodium carbonate or trypsin. The neutralization with hydrochloric acid was also omitted. The phaseolin fed to Rats 329 ♂ and 294 ♀ was simply boiled in distilled water for 30 minutes. The mixture was then evaporated to dryness on a steam bath. The residue was ground to a powder and supplemented with 2 per cent of cystine. Rats 261 ♂ and 262 ♀

during the first stage were placed on a diet containing phaseolin cooked in water. The second stage shows the remarkable improvement in the rate of growth due to the addition of 2 per cent of cystine to the cooked phaseolin.

The composition of the diet modified as stated above follows.

	<i>gm.</i>
Phaseolin (cooked, etc.)	19.60
Cystine	0.40
Protein-free milk	28.00
Starch	22.00
Agar	5.00
Butter fat	18.00
Lard	7.00
	100.00

Experiments with Navy Bean Meal.—Osborne and Mendel found that rats fed on raw bean meal declined rapidly in weight and soon died. When the bean meal was cooked slight growth was ob-

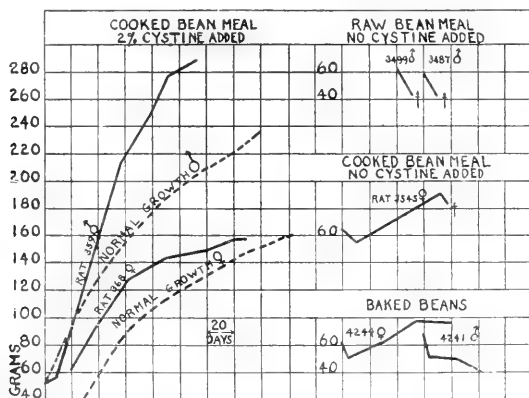

CHART 4. Rats 359 ♂ and 368 ♀ were fed on a diet containing cooked navy bean meal supplemented with cystine equivalent to 2 per cent of the protein. The bean meal was cooked with distilled water for 3 hours. The mixture was then evaporated to dryness and the residue ground to a powder to which cystine was added before preparing the diet. The excellent growth obtained shows that cooked navy beans, supplemented with cystine, furnished an adequate protein mixture.

The following data are taken from results obtained by Osborne and Mendel.

Rats 3499 ♂ and 3487 ♂ were fed on a diet in which the proteins were derived from raw navy bean meal. The curves show clearly the inadequacy

of this diet. Rat 3545 ♀ was fed on a diet in which the protein was furnished by cooked bean meal. It is evident that cooking the bean meal causes an improvement comparable to that resulting from cooking phaseolin. Rats 4244 ♀ and 4241 ♂ were fed on a diet in which the protein was supplied by beans baked without the addition of pork. It is evident that the proteins of the navy bean must be cooked and supplemented with cystine before they can become adequate for normal growth.

The composition of these diets follows.

	Rats 359♂, 368♀.	Rats 3499♂, 3487♂.	Rats 4244♀, 4241♂	Rat 3545♀.
	gm.	gm.	gm.	gm.
Cooked navy bean meal.....	71.64			
Raw navy bean meal.....		35		54
Baked beans.....			72	
Corn gluten.....		19		
Cystine.....	0.36			
Salt Mixture IV*.....	4.00		3	
Protein-free milk.....		21		22
Butter fat.....	15.00	18	18	18
Lard.....	9.00	7	7	6
	100.00	100	100	100

* For composition of salt mixture see Osborne, T. B., and Mendel, L. B., *J. Biol. Chem.*, 1917, xxxii, 374.

tained for some time. Baked beans showed no greater efficiency than cooked bean meal. We found that cooked navy bean meal supplemented with cystine equivalent to 2 per cent of its protein produced normal growth. This diet contained butter fat to furnish fat-soluble vitamins. The salts were furnished by an artificial salt mixture and the beans supplied sufficient water-soluble vitamins. The curves are shown in Chart 4.

Similar experiments are being made on the proteins of other leguminous seeds and the results obtained will be reported in future publications.

SUMMARY.

1. Cystine has been shown to be essential for normal growth.
2. Phaseolin, the principal protein of the navy bean, is rendered a more efficient food by heating with water.
3. Cooked phaseolin or cooked navy bean meal when supplemented with cystine furnished adequate protein for normal growth.

BIBLIOGRAPHY.

1. Ackroyd, H., and Hopkins, F. G., *Biochem. J.*, 1916, x, 551.
2. Totani, G., *Biochem. J.*, 1916, x, 382.
3. Hopkins, F. G., *J. Chem. Soc.*, 1916, cix, 629.
4. Osborne, T. B., and Clapp, S. H., *Am. J. Physiol.*, 1907, xviii, 295.
5. Osborne, T. B., and Mendel, L. B., *Z. physiol. Chem.*, 1912, lxxx, 307.
6. McCollum, E. V., Simmonds, N., and Pitz, W., *J. Biol. Chem.*, 1917, xxix, 521.
7. Finks, A. J., and Johns, C. O., *J. Biol. Chem.*, 1920, xli, 375.
8. Osborne, T. B., *Connecticut Exp. Station Rep.*, 1900, 443.
9. Mendel, L. B., and Fine, M. S., *J. Biol. Chem.*, 1911-12, x, 433.
10. Holmes, A. D., *U. S. Dept. Agric., States Relations Service Bull. 717*, 1918.
11. Osborne, T. B., and Mendel, L. B., *J. Biol. Chem.*, 1915, xx, 351.
12. Abderhalden, E., *Z. physiol. Chem.*, 1915, xcvi, 1.
13. Mitchell, H. H., *J. Biol. Chem.*, 1916, xxvi, 231.
14. Geiling, E. M. K., *J. Biol. Chem.*, 1917, xxxi, 173.
15. Lewis, H. B., *J. Biol. Chem.*, 1917, xxxi, 363.
16. Daniels, A. L., and Rich, J. K., *J. Biol. Chem.*, 1918, xxxvi, 27.
17. Osborne, T. B., *The vegetable proteins, Monograph on biochemistry*, London, New York, Bombay, and Calcutta, 1909, 69.

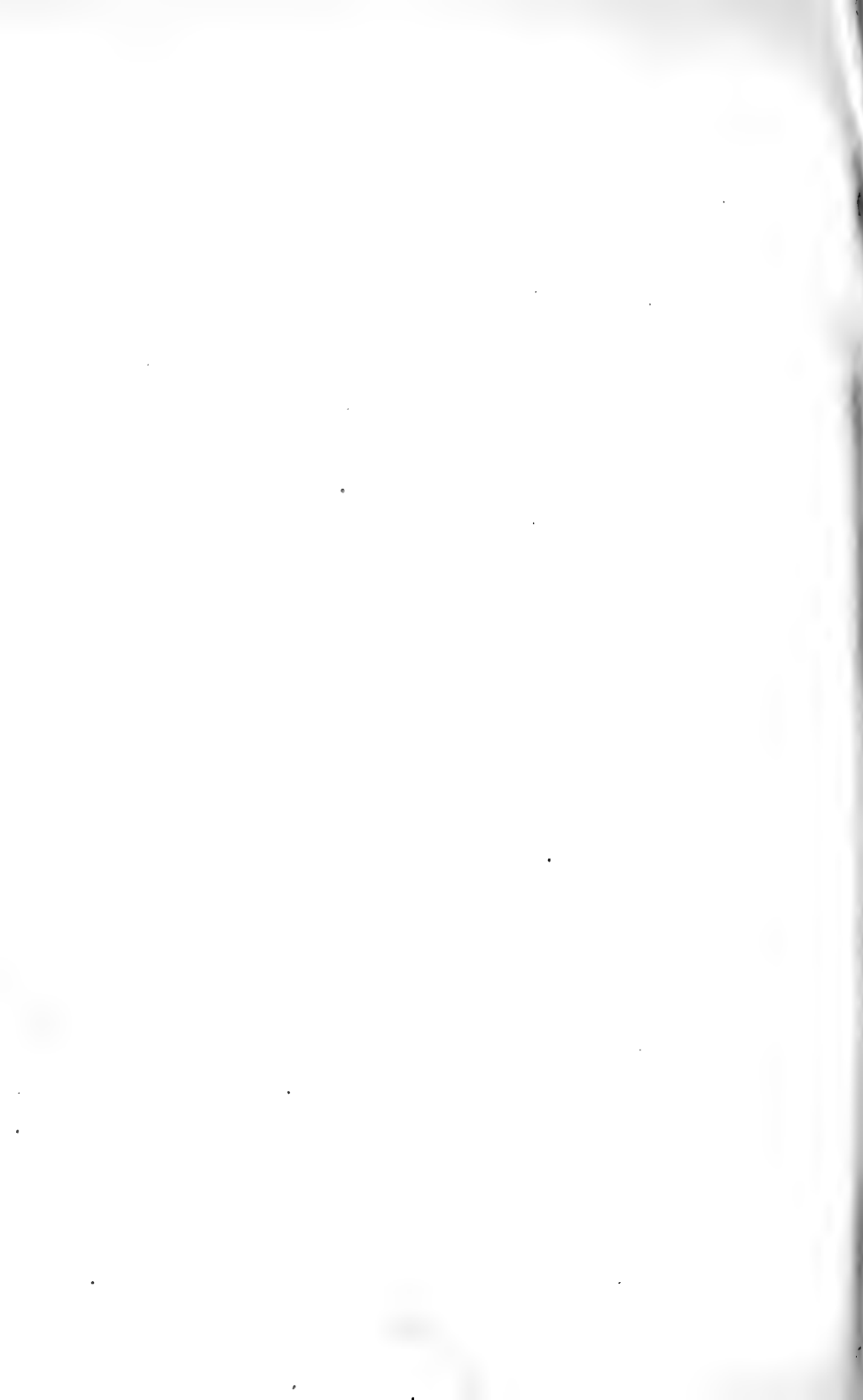

STUDIES IN NUTRITION.

III. THE NUTRITIVE VALUE OF COMMERCIAL CORN GLUTEN MEAL.

By CARL O. JOHNS, A. J. FINKS, AND MABEL S. PAUL.

(From the Protein Investigation Laboratory, Bureau of Chemistry, United States Department of Agriculture, Washington.)

(Received for publication, January 14, 1920.)

The fact that corn, *Zea mays*, is the most abundant cereal grown in the United States has led a number of investigators to study the nutritive value of its proteins. Among such studies are those made by Osborne and Mendel (1, 2, 3, 4), McCollum, Simmonds, and Pitz (5), Hart, Halpin, and McCollum (6), and Hogan (7, 8). These researches have contributed greatly to our present knowledge of the nutritive value of corn proteins.

Corn is known to contain several different proteins (9, 10) and the approximate distribution of these in the kernels of a sample of corn containing a relatively high percentage of proteins is shown in the following table which is taken from a publication by Osborne and Mendel (2).

	<i>Per cent of protein.</i>
Globulins + albumins + "proteoses"	21.9
Zein	41.4
Maize glutelin	30.8
Insoluble in alkali	5.9
	<hr/>
	100.0

Zein, which constitutes approximately from 41 to 52 per cent of the proteins in corn, lacks lysine and tryptophane, which are essential amino-acids for the growth of animals. It also contains but small quantities of the basic amino-acids which are also essential in a complete diet. Corn glutelin, which is the next most abundant protein, contains all the essential amino-acids which zein lacks and promotes normal growth. Osborne and Mendel

(11) also state that considerable growth can be obtained from corn embryos as the sole source of protein, likewise with a mixture of corn gluten and corn embryo when a sufficient quantity of the latter is present. We have, therefore, in corn a mixture of efficient and deficient proteins.

The chief difficulties in conducting nutrition experiments with ground whole corn as the sole source of protein is due to its relatively low percentage of protein. When the other essential components of the diet, namely, an adequate inorganic salt mixture, butter fat, and lard, are added, the percentage of protein is too low to expect normal growth.

The only abundant protein concentrates of corn on the market are commercial gluten meal and gluten feed. The gluten meal is obtained as a by-product in the manufacture of starch, dextrin, and syrup from corn. Approximately 600,000 to 700,000 tons of gluten meal and gluten feed are produced annually. The corn is steeped in water containing sulfur dioxide in order to soften it and is then ground under water and the mixture is strained through sieves to remove hulls, tip caps, and the embryos. The water containing the suspended starch and protein is passed over long troughs in which most of the starch settles. The protein passing out of the trough is filter-pressed and dried at a low temperature. This dried mixture is known commercially as gluten meal and is used extensively for making mixed cattle feeds. Gluten feed is made in the same manner but contains the residue obtained by evaporation of the steep water.

Several attempts have previously been made to grow white rats on corn gluten, prepared in various ways, as the sole source of protein. Osborne and Mendel have described nutrition experiments with gluten meal (2, 4). This gluten meal contained about 45 per cent of proteins. When this was the sole source of protein in the diet the rats maintained weight but made very little growth during an experiment which was continued for more than a year. The authors state that with this gluten meal (2) "more than very slow growth is impossible." When a part of the gluten meal was replaced by casein or lactalbumin normal growth was obtained. The inorganic salts and water-soluble vitamins were furnished by protein-free milk. The authors conclude their paper with the following statement: "It is perhaps not too utopian to expect that the day may come when amino-acid concentrates may serve to render perfect the mixtures of proteins in a fodder like maize or its commercial by-products." In a later publication (11) the same authors state that they have never yet been able to feed

a sufficient quantity of the proteins of the maize concentrate to effect normal growth although there is evidence that all the essential amino-acids are present in some part of the seed. They also state:

“Our experiments indicate that it ought to be possible to make an animal grow on a diet in which the maize kernel is the sole source of protein, provided a preparation of total proteins could be obtained which would permit feeding them in sufficient quantity so that enough of those amino-acids which are present in certain of the proteins and not in others would be available to meet the minimum nutritive requirements of the organism.”

McCollum, Simmonds, and Pitz (5) have also attempted to grow rats on a diet containing various mixtures of separate parts of the corn kernel but were not successful in obtaining normal growth.

Hogan has made extensive studies of the nutritive value of corn and its proteins. In one of his experiments (7) he fed a mixture of corn and commercial corn gluten meal as the sole source of protein in the diet and obtained surprisingly good growth. He states that corn gluten seemed more efficient than either egg white or dried blood as a supplement to corn but adds that it is possible that this result should be confirmed by a larger number of experiments before the fact can be considered established. In a later experiment (8) he attempted to grow rats on a corn protein concentrate which he prepared himself in order that the embryo, which is absent in commercial corn gluten meal, might be present, but the attempts were not successful and some of the rats died relatively soon. In these experiments the percentages of corn proteins in the diet were only 9 or 12 per cent so that no definite conclusions can be drawn as to the value of the protein concentrate.

The purpose of our experiments with commercial gluten meal was not only to determine its nutritive value but also to endeavor to find some cheap concentrate that could be used to supplement the proteins of the gluten since zein, which constitutes approximately one-half of these proteins, is deficient in lysine and tryptophane. As will be seen in the description of the experiments given below this could be accomplished by the addition of coconut press-cake to the gluten meal. Normal growth was also obtained when a mixture of ground whole corn and gluten meal furnished the sole source of proteins in the diet. This diet contained 21 per cent of corn proteins.

Experiments with Gluten Meal as the Sole Source of Protein.—A diet was prepared which contained 53 per cent of gluten meal. This is equivalent to 19.4 per cent of protein. To this were added

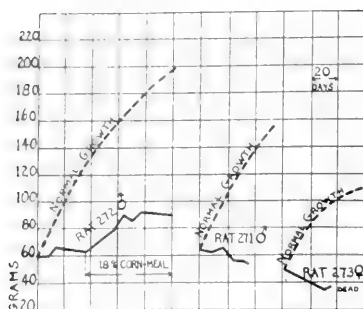

CHART 1. This chart shows the failure of rats to grow when gluten meal was the sole source of protein in the diet and no source of water-soluble vitamin was added. Rat 273 ♀ died in 36 days and the experiment was discontinued with Rat 271 ♂ at the end of that time, while 18 per cent of whole, ground, yellow corn replaced an equivalent amount of starch in the diet of Rat 272 ♂. This caused considerable growth for a short time; then growth ceased again. It is probable that Rat 272 ♂ was permanently injured by lack of water-soluble vitamin before the corn-meal was added. The composition of the diet before the adding of the ground corn was as follows:

Gluten meal.....	53	(Equivalent to 19.4 gm. of protein.)
Salt mixture*.....	4	
Starch.....	18	
Butter fat.....	18	
Lard.....	7	
—		
100		

* The composition of the salt mixture was as follows:

	gm.		gm.
CaCO ₃	134.8	Citric Acid + H ₂ O...	111.1
MgCO ₃	24.2	Fe citrate + 1½ H ₂ O.	6.34
Na ₂ CO ₃	34.2	KI.....	0.020
K ₂ CO ₃	141.3	MnSO ₄	0.079
H ₃ PO ₄	103.2	NaF.....	0.248
HCl.....	53.4	K ₂ Al ₂ (SO ₄) ₄	0.0245
H ₂ SO ₄	9.2		

Osborne, T. B., and Mendel, L. B., *J. Biol. Chem.*, 1917, xxxii, 374.

a suitable salt mixture, starch, butter fat, and lard. Three rats were placed on this diet but none of them made any appreciable growth and one died at the end of 36 days. Rat 272 maintained its weight for 36 days and at the end of that time the 18 per cent of starch was replaced by whole, ground, yellow corn. Considerable growth took place but the rate was below normal and soon ceased.

There were two factors either of which might be responsible for failure of the rats to grow on the diet consisting of gluten meal as the sole source of protein. It was not known whether or not the gluten meal furnished proteins adequate for normal growth and if the necessary water-soluble vitamine was present. This accessory, which is necessary for growth, goes into the steep water. Since this was not incorporated in the gluten meal used in our experiments, it seemed probable that the failure to obtain growth was due to the lack of water-soluble vitamine. The curves obtained in these experiments are shown in Chart 1.

Experiments with Gluten Meal and Brewers' Yeast.—The diet used in these experiments contained 53 per cent of gluten meal and 3 per cent of dried brewers' yeast together with a salt mixture, starch, butter fat, and lard. Since brewers' yeast has been shown to contain an abundance of water-soluble vitamine (12) any failure to grow could not be attributed to the lack of this dietary essential. Two rats were placed on this diet and as is shown by the curves in Chart 2 the rate of growth was above normal which was surprising in view of the results obtained by other investigators. It is very evident that the yeast furnished an adequate supply of water-soluble vitamine. Since yeast also contains proteins adequate for normal growth (13), the success obtained in this experiment might be partly due to the proteins of the yeast although it seemed improbable that the small quantity of proteins contributed by 3 per cent of yeast could have much effect on the rate of growth.

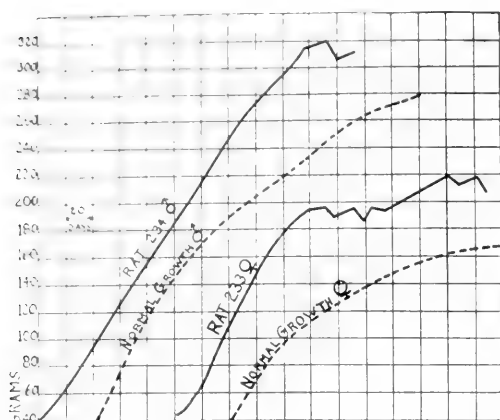

CHART 2. This shows excellent growth when gluten meal was the sole source of protein and the water-soluble vitamine was furnished by 3 per cent of dried brewers' yeast. With this exception the diet was similar to the one on which rats failed to grow (Chart 1). It is apparent that gluten meal contains a mixture of proteins adequate for normal growth. This contention is also borne out by the results shown by the curves in Chart 3 in which the water-soluble vitamine was furnished by 18 per cent of whole, yellow corn-meal.

The composition of the diet was as follows:

	<i>gm.</i>
Gluten meal.....	53 (Equivalent to 19.4 gm. of protein.)
Salt mixture.....	4
Starch.....	15
Dried brewers' yeast...	3
Butter fat.....	18
Lard.....	7

100

Experiments with a Mixture of Gluten Meal and Corn-Meal as the Sole Source of Protein and Water-Soluble Vitamine.—This diet contained 53 per cent of gluten meal and 18 per cent of yellow corn-meal made from the whole corn. Two rats were placed on this diet and their growth was remarkably good, the rate of growth of the female being normal. These results confirmed those obtained by Hogan (7, 8) on a similar diet and show that corn proteins of sufficient concentration in the diet are adequate for normal growth. It is also evident that 18 per cent of corn-meal

furnishes an adequate supply of water-soluble vitamine. It is probable, however, that the vitamine content of this diet was very near the minimum quantity required. The curves obtained in these experiments are shown in Chart 3.

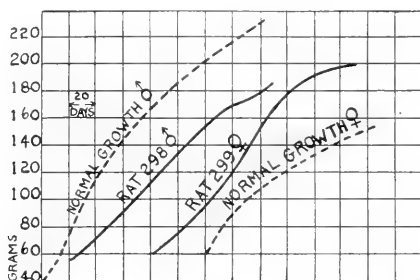

CHART 3. The curves in this chart show that normal growth can be obtained from a diet in which a mixture of gluten meal and ground corn furnishes the sole source of protein and water-soluble vitamine. The gluten meal contributed 19.4 per cent of protein in the diet while the ground corn contributed only 1.5 per cent. The water-soluble vitamine contributed by the ground corn was probably near the minimum requirement of this food accessory. The composition of the diet was as follows:

	<i>gm.</i>	
Gluten meal.....	53	(Equivalent to 19.4 gm. of protein.)
Salt mixture.....	4	
Whole ground corn.....	18	(Equivalent to 1.5 gm. of protein.)
Butter fat.....	18	
Lard.....	7	

100

Experiments with Mixtures of Gluten Meal and Coconut Press-Cake.—Although normal growth can be obtained from a diet in which concentrated corn proteins furnish the sole source of proteins, such a diet is probably not economical because approximately one-half of these proteins are deficient in lysine and tryptophane. It therefore seemed desirable to find a cheap protein concentrate which when mixed with gluten meal would contribute sufficient quantities of lysine and tryptophane to constitute an efficient mixture of proteins. Our previous work on the nutritive value of the proteins of coconut press-cake (14) suggested that this substance might be used advantageously for this pur-

pose. A diet was, therefore, prepared in which 25 per cent of corn gluten and 25 per cent of coconut press-cake furnished the sole source of protein. This diet contained 14 per cent of protein ($N \times 6.25$) of which approximately 9 per cent was furnished by corn gluten and 5 per cent by coconut press-cake. The rest of the diet consisted of a salt mixture, starch, butter fat, and lard.

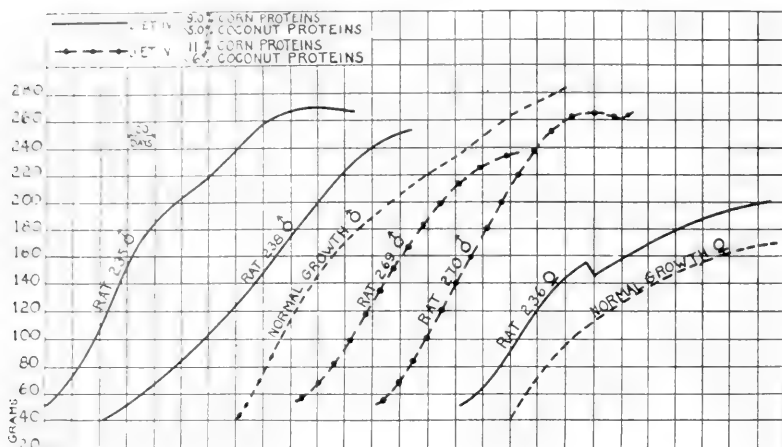

CHART 4. These curves show that excellent growth can be obtained when a mixture of gluten meal and coconut press-cake furnishes the sole source of protein and water-soluble vitamins in the diet. The high efficiency of this mixture is indicated by the results obtained on Diet IV which contained but 14 per cent of proteins of which only 5 per cent was furnished by the coconut press-cake. This indicates the value of coconut press-cake as a supplement to corn proteins. The compositions of Diets IV and V are as follows:

	Diet IV.	Diet V.
	<i>gm.</i>	<i>gm.</i>
Gluten meal	25	30
Coconut press-cake	25	31
Salt mixture	4	4
Starch	21	10
Butter fat	10	18
Lard	15	7
Total	100	100

The rats (Nos. 235, 238, and 236) fed on this diet grew normally, indicating an efficient mixture of proteins. It is also evident that 25 per cent of coconut press-cake furnished sufficient water-soluble vitamine for normal growth. A second diet containing 30 per cent of gluten meal and 31 per cent of coconut press-cake also gave excellent results. The growth obtained in these experiments is shown by the curves in Chart 4. Hence, it seems practical and economical to supplement gluten meal with coconut press-cake both for the purpose of supplementing the proteins of gluten meal and adding the water-soluble vitamine which gluten meal lacks.

SUMMARY.

1. Commercial corn gluten meal supplemented by dried brewers' yeast, whole, ground, yellow corn, or coconut press-cake furnishes the necessary protein for normal growth.

2. 18 per cent of whole, ground, yellow corn-meal furnishes sufficient water-soluble vitamine for normal growth.

BIBLIOGRAPHY.

1. Osborne, T. B., and Mendel, L. B., *J. Biol. Chem.*, 1914, xvii, 325.
2. Osborne, T. B., and Mendel, L. B., *J. Biol. Chem.*, 1914, xviii, 1.
3. Osborne, T. B., and Mendel, L. B., *J. Biol. Chem.*, 1916, xxvi, 293.
4. Osborne, T. B., and Mendel, L. B., *J. Biol. Chem.*, 1917, xxix, 69.
5. McCollum, E. V., Simmonds, N., and Pitz, W., *J. Biol. Chem.*, 1916-17, xxviii, 153.
6. Hart, E. B., Halpin, J. G., and McCollum, E. V., *J. Biol. Chem.*, 1917, xxix, 57.
7. Hogan, A. G., *J. Biol. Chem.*, 1916, xxvii, 193.
8. Hogan, A. G., *J. Biol. Chem.*, 1917, xxix, 485.
9. Chittenden, R. H., and Osborne, T. B., *Am. Chem. J.*, 1891, xiii, 453, 529.
10. Chittenden, R. H., and Osborne, T. B., *Am. Chem. J.*, 1892, xiv, 20.
11. Osborne, T. B., and Mendel, L. B., *J. Biol. Chem.*, 1918, xxxiv, 521.
12. Osborne, T. B., and Mendel, L. B., *J. Biol. Chem.*, 1917, xxxi, 149.
13. Osborne, T. B., and Mendel, L. B., *J. Biol. Chem.*, 1919, xxxviii, 223.
14. Johns, C. O., Finks, A. J., and Paul, M. S., *J. Biol. Chem.*, 1919, xxxvii, 497.



THE EQUILIBRIUM BETWEEN OXYGEN AND CARBONIC ACID IN BLOOD.

BY LAWRENCE J. HENDERSON.

(From the Chemical Laboratory, Harvard University, Cambridge.)

(Received for publication, January 24, 1920.)

I.

After many years of uncertainty, a very high degree of probability seems to have been established for the hypothesis that the absorption of oxygen by blood depends upon a chemical combination between oxygen and hemoglobin, $\text{Hb} + \text{O}_2 = \text{HbO}_2$, in which the molecular weight of hemoglobin has the lowest possible value, so that 1 atom of iron corresponds to 1 molecule of oxygen in the compound oxyhemoglobin.

This chemical equilibrium has been very thoroughly studied by Barcroft and his associates (1). As a result of their investigations it is known that pure solutions of hemoglobin combine with oxygen in such a manner that the requirements of the simple mass law equation

$$k = \frac{[\text{Hb}] \cdot [\text{O}_2]}{[\text{HbO}_2]} \quad (1)$$

are fulfilled. But when electrolytes are also present in the solution this relation is modified. Under such circumstances Barcroft has found that an equation developed by Hill¹

$$k = \frac{[\text{Hb}] \cdot [\text{O}_2]^n}{[\text{HbO}_2]} \quad (2)$$

expresses the conditions. In this equation, however, the values of n and k vary with the nature and concentration of the electrolytes. For human blood the value of n is always approxi-

¹ Barcroft (1), p. 60.

mately 2.5, and the expression becomes

$$k = \frac{[\text{Hb}] \cdot [\text{O}_2]^{2.5}}{[\text{HbO}_2]} \quad (3)$$

The theoretical significance of this expression, in spite of many cogent arguments, remains somewhat obscure. This question will be further considered below.

With constant temperature, the principal variation in the value of k in human blood depends upon variations of the concentration of free carbonic acid, a quantity which is determined

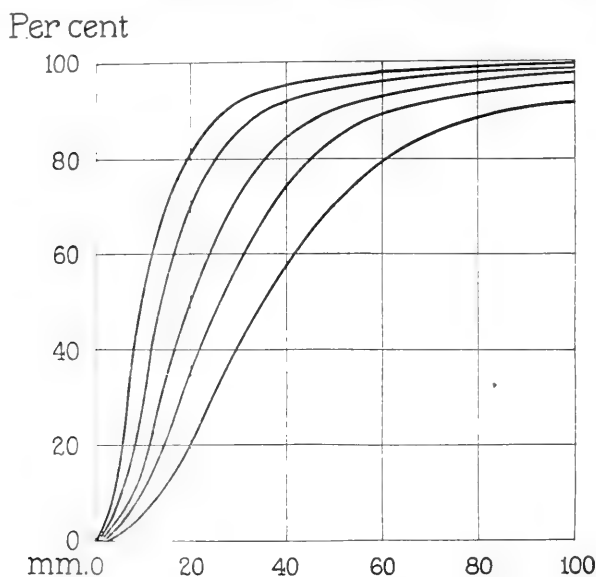

FIG. 1. Oxygen dissociation curves of Barcroft's blood, reading from left to right, exposed to 0, 3, 20, 40, and 90 mm. of CO_2 . Ordinates are percentage saturation; abscissa oxygen pressures in mm. of Hg.

by, and proportional to, the tension of carbon dioxide. This is the phenomenon discovered by Bohr, Hasselbalch, and Krogh (2). These conditions are illustrated by dissociation curves of Barcroft's blood² (Fig. 1).

For the curves of Fig. 1 the values of k (corresponding to $\frac{1}{K}$

² Barcroft (1), p. 65.

in Barcroft's notation) are as follows:

CO ₂ , mm.....	0	3	20	40	90
k.....	388	770	1,980	3,430	7,420

It may readily be seen, when the large variations in the values of k are noted, that we have no great assurance that the value of k for a single tension of carbon dioxide, *i.e.* for a single curve, is not affected with secondary variations, especially near the ends of the curves.

The simplicity of the mathematical expression also suggests that it should be possible to express the value of k in terms of $[\text{CO}_2]$, the tension of carbon dioxide, and thus to obtain the equation of the surface whose axes are percentage saturation with oxygen, oxygen pressure, and carbon dioxide pressure respectively. This expression turns out to be as follows:

$$\frac{[\text{CO}_2] + 7.7}{0.014} = \frac{[\text{Hb}] \cdot [\text{O}_2]^{2.5}}{[\text{HbO}_2]} \quad (4)$$

For, putting $k = \frac{[\text{CO}_2] + 7.7}{0.014}$ we get the following values:

[CO ₂], mm.....	0	3	20	40	90
k.....	550	764	1,980	3,410	6,980

These values correspond to those of Barcroft within 1 per cent throughout the greater part of the range of carbon dioxide tension, and differ sensibly only in case carbonic acid is entirely absent, a peculiarity which, on theoretical grounds, is to be expected.

When Equation 4 is written

$$\frac{[\text{CO}_2] + 7.7}{0.014 \cdot [\text{O}_2]^{2.5}} = \frac{[\text{Hb}]}{[\text{HbO}_2]}$$

it is evident, from general thermodynamical principles, since increasing the concentration of carbon dioxide results in an increase of the concentration of oxygen, that increasing the tension of oxygen must likewise increase the tension of carbon dioxide. This conclusion, as far as I can see, could fail only in case there were present something resembling a ratchet mechanism, by which the carbon dioxide could act upon the oxygen without the possibility of a corresponding reaction. But such mechanisms are at present unknown in physicochemical systems.

However this may be, the investigation of Christiansen, Douglas, and Haldane (3) has proved that oxygen does influence the tension of carbon dioxide in blood in the manner indicated by the theory.

II.

In blood all the carbonic acid is present either as free acid ($\text{CO}_2 + \text{H}_2\text{CO}_3$) or as bicarbonate ($\text{HCO}_3 + \text{BHCO}_3$). This conclusion, originally reached from a study of the general acid-base equilibrium of the blood (4, 5), has been verified with great accuracy by the investigation of Hasselbalch (6). If we express the concentration of free carbonic acid by $[\text{CO}_2]$ and the concentration of total bicarbonate including both undissociated molecules and the bicarbonate ions by $[\text{BHCO}_3]$, we may write the expression for the equilibrium between these substances in the approximate form

$$k_{\text{CO}_2} = [\text{H}] \frac{[\text{BHCO}_3]}{[\text{CO}_2]} \quad (5)$$

Here k_{CO_2} is a constant having for blood a value appreciably greater than that of the ionization constant of carbonic acid.

Equations 4 and 5 define the conditions for equilibrium between the hydrogen ion, carbonic acid, oxygen, hemoglobin, and bicarbonates in human blood. They are known to be true, at least with a fair approach to accuracy, on purely experimental grounds, independently of all theoretical considerations.

Several important conclusions follow directly from Equations 4 and 5. All of these, however, may be more clearly understood with the help of further theoretical considerations.

III.

The influence of carbonic acid upon the equilibrium between oxygen and hemoglobin must depend upon a chemical reaction in which both hemoglobin and carbonic acid are involved. Let us first consider the direct combination whereby hemoglobin bicarbonate is formed. For this purpose we may use Bohr's investigation (7) of the absorption of carbon dioxide by purified hemoglobin solutions.

From his numerous measurements Bohr drew the conclusion that the amount of carbonic acid united with hemoglobin varies with the tension of carbon dioxide so that, within those ranges of tension which exist in the blood, it amounts to about 0.5 cc. of CO₂ per gm. of hemoglobin. Bohr's experiments, however, were carried out in the absence of inorganic bicarbonates. Accordingly, the hydrogen ion concentration must have been very much higher than in blood. It follows that the amount of carbonic acid united to hemoglobin in blood must be at most very small, probably not more than 1 or 2 per cent by volume, and the variation of this quantity must be practically negligible.³ This subject will be discussed below.

Moreover, as Bohr showed (8), the union of carbonic acid with hemoglobin is uninfluenced by the presence of oxygen, so that this process cannot be involved in the phenomenon with which we are now concerned. In fact, as Bohr pointed out (8), it must be the globin portion of the hemoglobin molecule which combines with carbonic acid.

Secondly, we may examine the problem of the distribution of a base between carbonic acid and hemoglobin functioning as an acid. This seems to be the only remaining possibility of explaining the interaction of oxygen and carbon dioxide. It follows from this consideration, as suggested by Hasselbalch and Lunds-gaard (9), and by Christiansen, Douglas, and Haldane (3), and then more strongly asserted by Hasselbalch (6), and by Parsons (10), that oxyhemoglobin must be a stronger acid than reduced hemoglobin. Of course it also follows that the salts of hemoglobin must have a greater affinity for oxygen than has acid hemoglobin itself. Accordingly we seem to be concerned with the following different reactions:

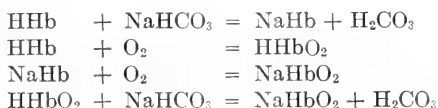

Moreover, all the substances involved in these reactions, except oxygen, ionize in a greater or less degree. In order to study this

³ I discussed this question with Professor Bohr at the Heidelberg Congress in 1907.

question we may turn to the data of Christiansen, Douglas, and Haldane (3), from which the first four columns of Table I are constructed by means of the curves on page 256 of their paper. Column 1 gives carbon dioxide pressures in mm.; Column 2 the corresponding concentrations of free carbonic acid in volumes per cent; Column 3 the total carbonic acid absorption of the blood when equilibrium is established in the presence of oxygen, so that practically all the hemoglobin is in the form of oxyhemoglobin; Column 4 the corresponding value when oxygen is absent, so that all the hemoglobin is in the reduced condition. From these values those of Column 5 = Column 3 - Column 2 and

TABLE I.

(1) CO ₂	(2) [CO ₂]	(3) Total CO ₂ O.*	(4) R.*	(5) [BHCO ₂] O.	(6) R.	+ [H] × 10 ⁹ N	
						(7) O.	(8) R.
<i>mm.</i>	<i>vol. per cent</i>	<i>vol. per cent</i>	<i>vol. per cent</i>	<i>vol. per cent</i>	<i>vol. per cent</i>		
5	0.34	20.0	24.0	19.7	23.7	1.28	1.09
10	0.67	28.5	32.5	27.8	31.8	1.86	1.67
20	1.34	38.5	43.5	37.2	42.2	2.92	2.61
30	2.02	46.5	51.5	44.5	49.5	3.78	3.43
40	2.69	51.5	57.0	48.8	54.3	4.62	4.30
50	3.36	56.0	62.0	52.6	58.6	5.44	4.95
60	4.03	59.5	66.0	55.5	62.0	6.20	5.65
70	4.70	63.0	69.5	58.3	64.8	6.93	6.30
80	5.38	66.5	73.0	61.1	67.6	7.63	6.97

* O = oxidized blood; R = reduced blood.

Column 6 = Column 4 - Column 2 are calculated. These give the combined carbonic acid of the fully oxygenated and of the fully reduced blood. Columns 7 and 8 give the corresponding values of hydrogen ion concentration in accordance with Equation 5 and the research of Hasselbalch (6). Column 7 refers to the oxidized and Column 8 to the reduced blood.

In Fig. 2 the values of Columns 5 and 6 are plotted against those of Columns 7 and 8, thus illustrating the change in combined carbonic acid which accompanies change in hydrogen ion concentration in fully oxidized and fully reduced blood, respectively.

Points on these two curves having the same abscissa are isohydric points. Accordingly the difference of their ordinates represents the amount of base transferred from carbonic acid to hemoglobin when fully reduced blood is fully saturated with

Vol. per cent

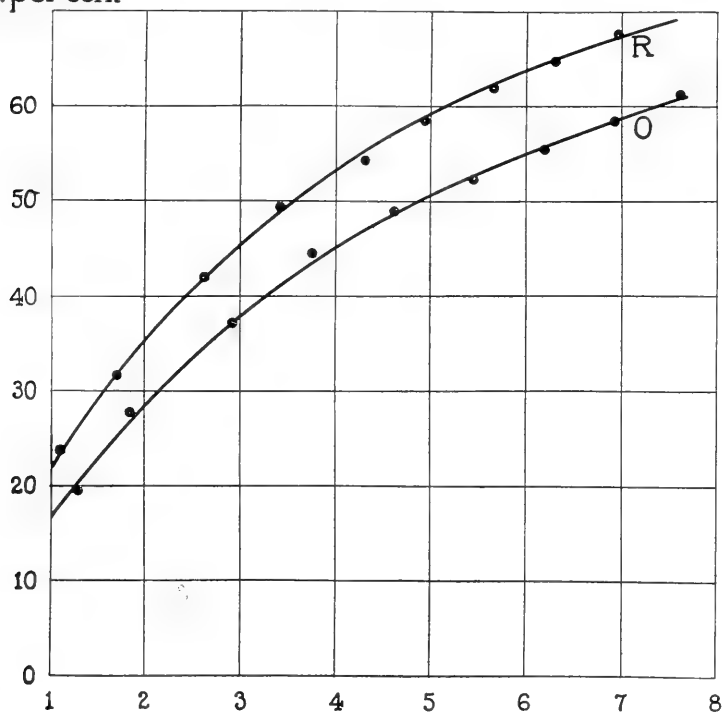

FIG. 2. Combined CO₂ as a function of $[H]^+$. Upper curve fully reduced blood; lower curve fully oxygenated blood of J. S. H. Ordinates are combined CO₂ in volumes per cent; abscissæ $[H]^+ \times 10^9 N$.

oxygen isohydrically; *i.e.*, in such a manner, by regulating the tension of carbon dioxide, as to keep the hydrogen ion concentration constant. The only acids that can be involved in this reaction are hemoglobin and carbonic acid, because while the hydrogen ion concentration remains constant other acid substances can neither combine with nor liberate base. But car-

bonic acid can do this if the tension of carbon dioxide is varied, and hemoglobin can do it if, by combining with oxygen, it becomes a stronger acid. Fig. 2 therefore affords a rigorous proof of the variation of the affinity of hemoglobin for base with variation in the amount of oxygen combined with hemoglobin. Thus the study of the isohydric properties of the system enables us to draw conclusions regarding the acid nature of hemoglobin. For the acid radical of hemoglobin which increases in strength when oxyhemoglobin is formed we may write mass law equations analogous to Equation 5 for carbonic acid.

$$k_R = [\text{H}^+] \frac{[\text{BHb}]}{[\text{HHb}]} \quad (6)$$

$$k_O = [\text{H}^+] \frac{[\text{BHbO}_2]}{[\text{HHbO}_2]} \quad (7)$$

It will be convenient to express concentrations of the various hemoglobin compounds in units of volumes per cent of oxygen and CO_2 , noting that $[\text{BHb}]$ and $[\text{BHbO}_2]$ stand for the total concentrations, both ionized and non-ionized, of the two salts. If we assume that the total concentration of hemoglobin for the blood of J. S. H. corresponds to 18 per cent by volume of oxygen or carbon dioxide and write

$$\begin{aligned} [\text{BHbO}_2] - [\text{BHb}] &= [\text{BHC}O_3]_R - [\text{BHC}O_3]_O = \Delta s \\ [\text{BHb}] &= s \end{aligned}$$

we find

$$\begin{aligned} [\text{HHb}] &= 18 - s \\ [\text{BHbO}_2] &= s + \Delta s \\ [\text{HHbO}_2] &= 18 - s - \Delta s \end{aligned}$$

values which hold for isohydric solutions both inclusively and exclusively.

The mass law equations then become

$$k_R = [\text{H}^+] \frac{s}{18 - s} \quad (8)$$

$$k_O = [\text{H}^+] \frac{s + \Delta s}{18 - s - \Delta s} \quad (9)$$

In order to solve these equations it is necessary to obtain two sets of values for $[H]^+$ and Δs . These may be obtained from Fig. 2, for example,

$$\begin{aligned} [H]_1^+ &= 2 \times 10^{-8} & \Delta s_1 &= 6.7 \\ [H]_2^+ &= 6 \times 10^{-8} & \Delta s_2 &= 8.8 \end{aligned}$$

whence

$$s_1 = \frac{27 s_2}{9 + s_2}$$

$$\frac{s_1 + 6.7}{11.3 - s_1} = \frac{3 s_2 + 26.4}{9.2 - s_2}$$

and

$$\begin{aligned} s_1 &= 9.64 \\ s_2 &= 5.00 \end{aligned}$$

Using these values we find for the two cases in question the values of Table II.

TABLE II.

$[H]_1^+ = 2 \times 10^{-8}$	$[BHb]_1 = 9.64$	$[BHbO_2]_1 = 16.34$	$k_R = 2.3 \times 10^{-8}$
	$[HHb]_1 = 8.36$	$[HHbO_2]_1 = 1.66$	$k_O = 19.7 \times 10^{-8}$
$[H]_2^+ = 6 \times 10^{-8}$	$[BHb]_2 = 5.00$	$[BHbO_2]_2 = 13.80$	$k_R = 2.3 \times 10^{-8}$
	$[HHb]_2 = 13.00$	$[HHbO_2]_2 = 4.20$	$k_O = 19.7 \times 10^{-8}$

From these values of k_R and k_O and Equations 8 and 9 it is possible to calculate all isohydric values of $[BHb]$ and $[BHbO_2]$, and therefore of Δs . Some of these are given in Table III.

TABLE III.

(1)	(2)	(3)	(4)
$[H]^+ \times 10^8 N$	$[BHb]$	$[BHbO_2]$	$\Delta s = (3) - (2)$
	<i>vol. per cent</i>	<i>vol. per cent</i>	<i>vol. per cent</i>
1	12.5	17.1	4.6
2	9.6	16.3	6.7
3	7.8	15.6	7.8
4	6.6	15.0	8.4
5	5.6	14.4	8.8
6	5.0	13.8	8.8
7	4.5	13.3	8.8
8	4.0	12.8	8.8
9	3.7	12.4	8.7

It may readily be seen that these values of Δs approximately correspond with the differences in the ordinates of the two curves of Fig. 2. Only in the neighborhood of $[\text{H}^+] = 1 \times 10^{-8}$ is there a significant discrepancy. But since the shape of the curves of Christiansen, Douglas, and Haldane is uncertain in this range ($[\text{CO}_2] < 10$ mm.) it is impossible to attach any significance to this difference. On the other hand it must be carefully noted that the relative values of k_R and k_O depend upon differences between the several values of Δs obtained from the data of Christiansen, Douglas, and Haldane. These differences are highly uncertain. Accordingly it is hardly worth while to attempt accurately to determine the absolute magnitude of the constants. Nevertheless it is easy to show mathematically that the range of this variation consistent with the general character of the data of Christiansen, Douglas, and Haldane is very limited. Accordingly, we may say that the order of magnitude of these quantities is given by the equations

$$k_R = 2.3 \times 10^{-8} \quad (10)$$

$$k_O = 2.0 \times 10^{-7} \quad (11)$$

IV.

While the considerations above set forth afford a possible, and, as I believe, the real explanation of the influence of oxygen upon the absorption of carbon dioxide by blood, it is evident that the fluctuation in the amount of alkali combined with a single acid radical of hemoglobin is far from sufficient to account for the variation of $[\text{BHCO}_3]$ with varying $[\text{H}^+]$. The facts are illustrated in Table IV. Column 4 gives the quantities of base that can be accounted for, on the above considerations, in the blood at the hydrogen ion concentrations indicated in Column 1. It will be seen that for $[\text{H}^+] = 7 \times 10^{-8} \text{N}$ basic radicals chemically equivalent to about 70 per cent by volume of carbon dioxide are in evidence, while at a hydrogen ion concentration one-fourth as great an amount equivalent to only 40 per cent by volume is accounted for. What has become of the remainder? In some measure basic radicals have become free, as in the case of a portion of those of globin which were directly united with carbonic acid.

This is, however, a negligibly small factor. The great majority of the missing basic radicals have combined with other weak acid radicals. Thus a large fraction of whatever phosphoric acid may be present has been converted from molecules of the type BH_2PO_4 to B_2HPO_4 . But this again represents a small fraction of the total.⁴ Probably a considerable number of other substances are more or less involved in this same manner. But in a considerable degree it must be the acid radicals of the proteins which are in question. Of these there is an indefinitely large supply. They are present in the protein portion of the hemoglobin molecule and in all the proteins of the plasma. In short we come back to the old reaction, so often discussed,

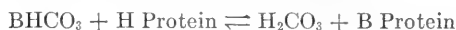

TABLE IV.

(1) $\frac{+}{[\text{H}]} \times 10^3 \text{N}$	(2) [BHCO ₃] ₀	(3) [BHbO ₂]	(4) B = (2) + (3)
	<i>vol. per cent</i>	<i>vol. per cent</i>	<i>vol. per cent</i>
2	29.6	16.3	46
3	38.0	15.6	54
4	44.8	15.0	60
5	50.3	14.4	65
6	54.9	13.8	69
7	58.5	13.3	72

It is important to consider this reaction because there is danger of confounding the unique case of hemoglobin above discussed with the universal property of all proteins and so overlooking or misconceiving the latter.⁵ Moreover the acid radical of hemoglobin which has been in question is not only unique in its properties, it is probably not even a protein radical at all, but a radical of the hematin part of the molecule.

⁴ My original discussion of the theory of neutrality regulation (4, 5) has often been misunderstood at this point. I have not intended to imply that phosphates are important in the regulation of the reaction of the blood, unless in blood cells of species where much phosphoric acid is present, but rather in the body as a whole, *i.e.* in the tissues, and in the process of excretion.

⁵ This appears to be the only source of difference between certain conclusions which Parsons has reached (10) and the corresponding conclusions of this paper.

Every protein molecule contains a considerable number of acid and basic radicals. The researches of Sørensen (12) show that these radicals obey the ordinary laws of chemical equilibrium and my own experience with gluten (13) indicates that they conform to the simple laws with considerable accuracy, even under the most varied colloidal conditions. But since the several acid radicals of a protein possess different ionization constants the behavior of a protein, as the hydrogen ion concentration varies, corresponds, not to that of the solution of a single weak acid, but to that of a mixture of a considerable number of weak acids. Thus, if we calculate an ionization constant in the usual manner, we find that this varies with the hydrogen ion concentration. Nevertheless the change in this apparent ionization constant for small changes of hydrogen ion concentration is small and it ought not to be difficult roughly to test the question whether the protein may probably be accounted the cause of a considerable part of the variation in $[\text{BHCO}_3] + [\text{BHbO}_2]$ with varying $[\text{H}^+]$.

From Table IV it may be seen that on the assumption that proteins alone are involved, the variation in the amount of base in union with protein in blood between $[\text{H}^+] = 1 \times 10^{-8}\text{N}$ and $[\text{H}^+] = 1 \times 10^{-7}\text{N}$ must be equivalent to about 50 per cent by volume of carbonic acid. Such a variation of the quantity of base would correspond, in round numbers, to 2 mols of base per mol of protein in the blood as a whole, assuming that the other proteins average the same molecular weight as hemoglobin. In other words, while passing from $[\text{H}^+] = 1 \times 10^{-8}\text{N}$ to $[\text{H}^+] = 1 \times 10^{-7}\text{N}$, somewhat less than 10,000 gm. of the mixed protein of the whole blood must give up 1 mol of base, if the phenomenon is ascribed to the basic radicals of the proteins alone.

It is easy to see that if, on the average, every 500 gm. of blood protein contains 1 mol of acid radical of such a nature that in the range between $[\text{H}^+] = 1 \times 10^{-8}\text{N}$ and $[\text{H}^+] = 1 \times 10^{-7}\text{N}$ all these radicals together behaved approximately like so many acid radicals of the strength $k = 5 \times 10^{-10}$ the necessary condition would be fulfilled. This appears to be a possible assumption, although it is not impossible that the proteins are on the whole even weaker acids and that small quantities of other substances

such as weak organic acids or organic compounds of phosphoric acid may be involved in a small degree. For comparison it may be noted (13) that about 30,000 gm. of gluten are required to liberate 1 mol of base between $[H] = 1 \times 10^{-8}N$ and $[H] = 1 \times 10^{-7}N$. In the case of the serum proteins (14, 15) the necessary amount of protein is only about 15,000 gm. It must be remembered, however, that globin differs from these.

Certain observations of Hasselbalch,⁶ although inconclusive, suggest that the acid radicals of globin may be strong enough to account for nearly the whole change within the corpuscles. The isoelectric point of hemoglobin suggests the same conclusion.

In any case it is evident that the facts are consistent with the general theory of acid-base equilibrium and the well established properties of proteins. The newly discovered property of hemoglobin does not lead to new difficulties, but, on the contrary, removes at least one serious difficulty of long standing. It is to illustrate this fact that the present section has been written, and no claim is made whatever for the accuracy of the estimates which are involved.

V.

Equations 6 and 7 yield the equation

$$\frac{k_O}{k_R} = \frac{[BHbO_2] \cdot [HHb]}{[BHb] \cdot [HHbO_2]} \quad (12)$$

For infinite dilution the mass law equations for the reactions

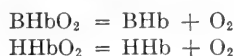

have the simple form

$$k_s = [O_2] \frac{[BHb]}{[BHbO_2]} \quad (13)$$

$$k_A = [O_2] \frac{[HHb]}{[HHbO_2]} \quad (14)$$

whence

$$\frac{k_A}{k_s} = \frac{[BHbO_2] \cdot [HHb]}{[BHb] \cdot [HHbO_2]} \quad (15)$$

⁶ Hasselbalch (6), p. 130.

and from Equations 12 and 15

$$\frac{k_A}{k_s} = \frac{k_O}{k_R} \quad (16)$$

Finally this expression, together with the approximations of Equations 10 and 11, gives

$$\frac{k_A}{k_s} = 9 \quad (17)$$

In spite of the fact that Equation 17 is a very rough approximation, it will be convenient to employ it as a means of estimating the probable effect that carbonic acid exerts upon the

TABLE V.

(1) $\frac{+}{[\text{H}]} \times 10^5 \text{N}$	(2) [BHb]	(3) [HHb]	(4) k_1 Calculated.	(5) K Barcroft.	(6) $\frac{(5)}{(4)}$
	<i>vol. per cent</i>	<i>vol. per cent</i>			
1	12.5	5.5	3.6	764	210
2	9.6	8.4	5.1	1,265	250
3	7.8	10.2	6.0	1,980	330
4	6.6	11.4	6.6	2,770	420
5	5.6	12.4	7.0	3,620	520
6	5.0	13.0	7.4	4,560	620
7	4.5	13.5	7.7	5,560	720
8	4.0	14.0	7.9	6,700	850
9	3.7	14.3	8.1	8,000	990

affinity of hemoglobin for oxygen. In Table V, Columns 1 and 2 of Table III are reproduced, Column 3 gives values of $[\text{HHb}] = 18 - [\text{BHb}]$, Column 4 gives values of the apparent constant $k = [\text{O}_2] \frac{[\text{Hb}]}{[\text{HbO}_2]}$ which these imply, according to the relation⁷

$$k = k_s \frac{[\text{BHb}]}{18} + 9 k_s \frac{[\text{HHb}]}{18}$$

These calculated values of k correspond to the requirements of the theory for fully reduced blood at infinite dilution. The differences in the values are maxima, for as the blood takes up

⁷ Note that $9k_s = k_A$.

oxygen there is increasingly less and less difference between the amounts of base in union with hemoglobin at any two hydrogen ion concentrations. Column 5 contains values of k (equal to $\frac{1}{K}$ of Hill's formula) obtained from Barcroft's data. The scales of the two k 's differ and it is therefore necessary to compare their ratios, which are given in Column 6.

Evidently there is no agreement between k as calculated and the K of Barcroft and Hill, save that they vary in the same sense. But this is inevitable, since the original assumptions, on which the value of the calculated k depends, rest upon the phenomenon which finds expression in Hill's formula in an increase of k , *i.e.*, a decrease of Hill's K , with increase of $[H^+]$; *i.e.*, with increase of $[CO_2]$.

This is the first real difficulty which we have encountered. The difficulty is real, because, first, the value of $\frac{k_A}{k_s}$, though uncertain, seems to be far too small to account for the variation in Barcroft's K , and secondly because it is evident that Barcroft's K should vary in accordance with the variation of k as theoretically calculated. This may readily be seen by writing equations according to Hill for the dissociation of acid oxyhemoglobin and its salt.

$$k_A = \frac{[HHb] \cdot [O_2]^{2.5}}{[HHbO_2]}$$

$$k_s = \frac{[BHb] \cdot [O_2]^{2.5}}{[BHbO_2]}$$

Then, as before,

$$\frac{k_A}{k_s} = \frac{[BHbO_2] \cdot [HHb]}{[BHb] \cdot [HHbO_2]}$$

Therefore, if Hill's expression not only permits the accurate calculation of points on the oxygen dissociation curve of blood, but also represents the real mechanism of the reaction, it appears to follow that

$$\frac{k_A}{k_s} > 100$$

Indeed it would seem probable that this is far too low an estimate, because, throughout the greater part of the absorption curves, when oxygen has already caused a further union between hemoglobin and base the values of k may be expected to vary less and less between the curves of different tensions of carbon dioxide.

This consideration, moreover, casts a doubt upon the validity of Hill's curves as an expression of the real mechanism of the reaction. For, since the union of oxygen with hemoglobin must increase the union of hemoglobin with base and since, on general thermodynamical principles, this must in turn increase the affinity of hemoglobin for oxygen, it follows that, unless there is some compensatory process of an unknown nature, the value of k for a given tension of carbon dioxide must be itself a function of $[O_2]$ and therefore a variable. Thus it may be seen that the problem is somewhat more complex than is implied even by the searching analysis of Barcroft and Hill.

Returning to the discrepancy between the calculated values of k and those given by Barcroft and Hill, it may be said, on chemical grounds, that an increase in the affinity of the acid radical in question greater than that obtained by calculation, for example,

$$4 < \frac{k_A}{k_s} < 20$$

is hard to accept.

It seems necessary to suppose that this acid radical is located in the heme portion of the molecule, and that its position is very close to that taken by oxygen when it combines with hemoglobin. If the position were α or β to that of an atom with which oxygen is united, a sensible effect upon the two affinities would correspond with general chemical experience. This is also the reason for assuming that a single acid radical is in question. It seems certain that this number must be very small. At a much greater distance analogy suggests that this effect is out of the question. Perhaps the difference of the ionization constants of propionic acid, $k = 0.000014$, and lactic acid, $k = 0.00014$, is worth consideration.⁵ It must not be forgotten, however, that the heat of formation of lactic acid from propionic acid is much greater than the heat of formation of oxyhemoglobin from hemoglobin.

⁵ This same comparison has been made by Parsons (10).

On the other hand it is to be considered that in the latter case 2 atoms of oxygen are involved. And of course it is not inconceivable, although probably it does not agree with conceptions now held, that the addition of oxygen takes place upon the very atom which binds the alkali also.

The data of Christiansen, Douglas, and Haldane seem to be inconsistent with the conceivable hypothesis that the dissociable oxygen is an essential part of this acid radical, for then the values of Δs would be much higher in the more alkaline than in the more acid range.

Finally, however, it seems almost certain that, if the difference between k_{-1} and k_s were of the order of magnitude indicated by Hill's theory, every preparation of blood in which there is a considerable amount of oxygen in combination would have nearly the same affinity for base, and therefore for oxygen, as every other, regardless of the tension of carbon dioxide. If this is true, Hill's equation cannot be regarded as a valid expression of the real mechanism of the reaction, though I have no doubt of its validity as a means of calculating points on the absorption curves.

Stated in the most general terms, the work of Barcroft conclusively proves that, in the presence of electrolytes and therefore in blood, the active mass of hemoglobin is different from that value which can be calculated from the absorption of oxygen. If we take this conclusion for granted and abandon the attempt theoretically to account for it, just because we are thereby freed from a theoretical interpretation, we are able tentatively to take a further step. For it seems to be probable, and I think the constancy of Hill's n for all values of $[\text{CO}_2]$ strongly supports the view, that with a given percentage saturation of hemoglobin, regardless of the tension of carbon dioxide, the active masses of oxyhemoglobin and of reduced hemoglobin are more or less roughly constant. For example, it seems justifiable to assume that for all samples of blood which are just half saturated with oxygen approximately

$$\frac{[\text{Hb}]}{[\text{HbO}_2]} = \frac{[\text{HHb}] + [\text{NaHb}]}{[\text{HHbO}_2] + [\text{NaHbO}_2]} = \text{Constant}$$

though of course it is by no means equally possible to assume that

$$\frac{[\text{Hb}]}{[\text{HbO}_2]} = 1$$

If this is true the expression

$$k = [\text{O}_2] \frac{[\text{Hb}]}{[\text{HbO}_2]}$$

may be assumed to hold, with the qualification that we have at present no means of estimating the values of $[\text{Hb}]$ or $[\text{HbO}_2]$, which now stand for the true active masses, or even of $\frac{[\text{Hb}]}{[\text{HbO}_2]}$.

Nevertheless there is reason to suppose that the values of this ratio are constant for all cases where the saturation of the blood with oxygen has the same value, regardless of the tension of carbon dioxide.

This enables us to use Barcroft's curves for the calculation of values of k which, for any given degree of saturation of the blood

TABLE VI.

$\frac{[\text{Hb}]}{[\text{HbO}_2]}$	9.00	2.33	1.00	0.43	0.11
$[\text{CO}_2]$	Oxygen tensions.				
<i>mm.</i>	<i>mm.</i>	<i>mm.</i>	<i>mm.</i>	<i>mm.</i>	<i>mm.</i>
0	4	7	10	15	26
3	6	10	14	20	35
20	8	14	20	29	49
40	10	18	26	37	61
90	14	25	35	50	85

with oxygen, *i.e.* for any given ordinate, are probably comparable, though for different ordinates they are not comparable.

Table VI gives data taken from Fig. 1 of the values of $[\text{O}_2]$ in mm.

These data of Table VI yield the relative values of k given in Table VII. The calculation consists in dividing the oxygen tension for any particular degree of saturation and carbon dioxide tension by that for the same percentage saturation and 0 mm. of carbon dioxide tension.

It must be understood that the values of k given by Table VII are relative, and comparable only within each column of the table taken by itself. It is evident, however, that aside from errors in reading Barcroft's curves all the columns are identical, so that Table VII reduces to the very simple form of Table VIII.

Of course the identity of the columns of Table VII depends upon a mathematical property of Hill's equation, and the exact agreement cannot therefore be significant for the present discussion. But since Barcroft's curves agree, within the limits of experimental accuracy, with the observations, we are nevertheless justified in using Table VIII, which has just as much validity as the assumption that for any one percentage saturation the active masses of hemoglobin and of oxyhemoglobin are constant with varying tensions of carbon dioxide. And of course it has no more validity than this.

TABLE VII.
Values of k .

1.00	1.00	1.00	1.00	1.00
1.50	1.43	1.40	1.33	1.35
2.00	2.00	2.00	1.93	1.89
2.50	2.55	2.60	2.47	2.35
3.50	3.55	3.50	3.33	3.27

TABLE VIII.

[CO ₂]	k
<i>mm.</i>	
0	1.0
3	1.4
20	2.0
40	2.5
90	3.4

We are now in a position to compare values of k obtained from Barcroft's data by an assumption which, I think, is certainly not less reasonable than that involved in Hill's equation, with values of k calculated from the values of k_A and k_s . For this purpose we may take the case of fully reduced blood as represented by Column 4 of Table V. Table IX gives the necessary values.

Column 4 of Table IX, giving the ratios of the two values of k , unlike the similar column of Table V, contains values which are roughly constant. I think we are therefore justified in saying that, after all, the influence of carbonic acid upon the affinity of blood for oxygen does probably correspond with the requirements

of the theory of acid-base equilibrium. At any rate there is certainly no decisive evidence of inconsistency.

Since Barcroft has proved the active masses of hemoglobin and oxyhemoglobin to be different from the apparent values, it is evident that there may be a discrepancy between the combination of hemoglobin with base as indicated by theory, and the actual facts. This consideration raises a doubt regarding the validity of the present quantitative conclusions in general, which the above calculation cannot wholly remove. It must be remembered, however, that there is much evidence to prove that under all sorts of colloidal conditions the union of proteins with bases and acids corresponds closely with the requirements of the mass law. We are therefore not only permitted but obliged to go as far with this theory as we can.

TABLE IX.

(1) [CO ₂]	(2) k Table VIII. *	(3) k Calculated.	(4) $\frac{(3)}{(2)}$
<i>mm.</i>			
3	1.4	3.8	2.7
20	2.0	5.7	2.9
40	2.5	6.7	2.7
90	3.4	7.8	2.3

Moreover, if we write equations as follows:

$$k_R = \frac{+}{[H]^{2.5}} \frac{[BHb]}{[HHb]}$$

and

$$k_O = \frac{+}{[H]^{2.5}} \frac{[BHbO_2]}{[HHbO_2]}$$

which correspond to Hill's assumption, it appears that the values

$$k_R = 7.8 \times 10^{-20}$$

$$k_O = 110 \times 10^{-20}$$

yield results which agree roughly with the facts and permit the same conclusions that have been deduced from the assumptions made in this paper. It will be seen that even here the value of

the ratio $\frac{k_O}{k_R}$ corresponds with what is to be expected on chemical grounds.

It remains true, however, that we have no satisfactory means of accounting for the fact that according to Hill's formula, at least in its original implication, the difference in affinity for oxygen at any two tensions of carbon dioxide is independent of the amount of combined oxygen. The doubts expressed by Barcroft,⁹ concerning the validity of the theoretical curves in their upper ranges, nevertheless suggest a possible escape from this final complication.

VI.

Bohr's data (11) of the absorption of carbon dioxide by solutions of hemoglobin make possible a rough estimate of the extent to which hemoglobin combines with carbonic acid in blood. For example, we may make use of his results for a solution containing 3.8 per cent hemoglobin.

In Table X, Column 1 gives the tension of carbonic acid, Column 2 the dissolved free carbonic acid, Column 3 total dissolved carbonic acid, and Column 4 (Column 3 - Column 2) combined carbonic acid in cc. of gas for 37.8 cc. of solution. From these data Column 5 is calculated according to the expression

$$[\text{H}^+] = 6 \times 10^{-7} \frac{[\text{CO}_2]}{[\text{BHC}_3\text{O}_3]}$$

The values of Column 5 represent minimum values for the hydrogen ion concentration, which are probably sensibly too low and which must therefore lead to an overestimate rather than to an underestimate of the combination of hemoglobin with carbonic acid in blood.

Extrapolation indicates that for $[\text{H}^+] = 0.35 \times 10^{-7}N$ the value of $[\text{BHC}_3\text{O}_3]$ should be about 0.75 cc., which agrees with the approximation that for low values of the hydrogen ion concentration, the value of $[\text{BHC}_3\text{O}_3]$ should be directly proportional to $[\text{H}^+]$. This quantity is an estimate of the total quantity of acid which may be regarded as combined with hemoglobin functioning as a base at $[\text{H}^+] = 0.35 \times 10^{-7}N$ in 37.8 cc. of solution containing

⁹ Barcroft (1), p. 59.

3.8 per cent hemoglobin. From this the total salt formation s of hemoglobin functioning as a base, expressed in units of per cent by volume, for blood containing 14 per cent hemoglobin may be obtained as follows:

$$s = \frac{0.75}{37.8} \times \frac{14}{3.8} \times 100$$

whence

$$s = 7.3 \text{ per cent by volume}$$

This estimate represents the sum of the concentrations of all undissociated salt molecules formed of hemoglobin with all the

TABLE X.

(1)	(2)	(3)	(4)	(5)
CO ₂	[CO ₂]	Absorbed CO ₂ .	[BHCO ₃]	$\frac{+}{[H]} \times 10^7 N$
<i>mm.</i>	<i>cc.</i>	<i>cc.</i>	<i>cc.</i>	
6.04	0.275	2.098	1.823	0.90
11.57	0.527	2.885	2.358	1.35
14.62	0.666	3.230	2.564	1.55
18.54	0.844	3.666	2.822	1.80
24.07	1.095	4.197	3.102	2.10
31.98	1.455	4.855	3.400	2.55
43.14	1.963	5.715	3.752	3.15
60.03	2.731	6.815	4.084	4.05
85.40	3.886	8.335	4.449	5.25
124.96	5.684	10.507	4.823	7.10
188.62	8.583	13.828	5.245	9.85

acids of the corpuscles, plus the concentration of hemoglobin cations. Since these salts include those of all acids, it seems safe to say that hemoglobin bicarbonate cannot amount to even one-third of the total. Roughly about 2 per cent by volume seems therefore to be the highest possible estimate. It is also evident that for changes of hydrogen ion concentration, which are physiologically significant, the change in concentration of hemoglobin bicarbonate is negligible.

Experiments with blood involving wider changes of hydrogen ion concentration may, however, lead to sensible variations in the concentration of hemoglobin bicarbonate. Thus, for the range $[H] = 1 \times 10^{-5} N$ to $[H] = 1 \times 10^{-7} N$ the variation of hemo-

globin bicarbonate concentration is perhaps nearly 5 per cent by volume, and, as Table X shows, for higher values of $[H]$ this variation may be important. It must be noted, however, that such ranges of reaction cannot be reached except in the absence of the normal bicarbonates of the blood and in the presence of carbon dioxide at high tensions.

VII.

The changes which actually take place in the blood as a result of absorption of oxygen and escape of carbonic acid in the lung, followed by escape of oxygen and absorption of carbonic acid in the tissue, may now be considered. It is true that for this purpose we do not yet possess all the desirable experimental information, and it is evident that quantitatively the considerations developed in the preceding sections leave much to be desired. Nevertheless there seems to be little doubt about the general characteristics of the physiological process.

In the lung the escape of carbonic acid causes a transfer of base from this acid to the proteins, the phosphates, etc., and to the acid radical peculiar to hemoglobin. Meanwhile the absorption of oxygen leads to an increase in the concentration of oxyhemoglobin. Each of these processes facilitates the other, for while union of base with hemoglobin increases the affinity for oxygen the union of oxygen with hemoglobin increases the affinity for base. In the tissues these processes, and with them the affinity changes, are reversed. Such is the nature of the primary phenomenon, in accordance with the theoretical considerations of Sections III and V of this paper. An incomplete representation of the process is given by the accompanying diagram:

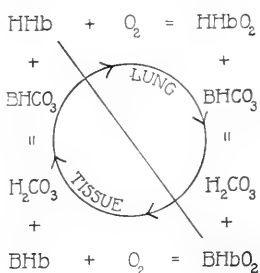

Certain cases of this cycle, which are indeed beyond the range actually occurring in the body, but which illustrate the principles involved, are defined by the data and the deductions above set forth.

Let us consider, for example, the case of blood in equilibrium, at a temperature of 38° , with an atmosphere consisting of ordinary air to which enough carbon dioxide has been added to make its tension 20 mm. This blood, as we have seen, will have approximately the following composition:

CO ₂	Oxygen absorption.	[BHbO ₂]	[HHbO ₂]	[BHCO ₃]	⁺ [H]
mm.	per cent	vol. per cent	vol. per cent	vol. per cent	
20	100	15.7	2.3	37.2	$2.92 \times 10^{-8}N$

When this preparation is brought into equilibrium with an atmosphere free from oxygen in which the tension of carbon dioxide is 60 mm. the following conditions will be established:

CO ₂	Oxygen absorption.	[BHb]	[HHb]	[BHCO ₃]	⁺ [H]
mm.	per cent	vol. per cent	vol. per cent	vol. per cent	
60	0	5.3	12.8	62.0	5.65×10^8N

In such a case the effect of carbon dioxide upon the oxygen absorption is of course obscured. But, in default of other data, it is necessary to take instances where the oxygen absorption is either 0 or 100 per cent. Even here the *process* has, of course, been modified by the changing affinity of hemoglobin for oxygen. The defect is, however, not a serious one, since Barcroft's data (1), and those of Bohr, Hasselbalch, and Krogh (2) before him, sufficiently illustrate this point.

The increase in combined carbonic acid in the above imaginary experiment is evidently $62.0 - 37.2 = 24.8$ per cent by volume. This has been made possible by the liberation of an amount of base equivalent to $15.7 - 5.2 = 10.5$ per cent by volume from the acid radical peculiar to hemoglobin. The remainder of the base, equivalent to $24.8 - 10.5 = 14.3$ per cent by volume, has come from the proteins, including globin, and other buffer substances. This estimate is subject to a slight, but practically negligible, correction owing to the variation in the amount of hemoglobin bicarbonate.

If the hemoglobin did not vary in affinity for base, the increase in the amount of absorbed carbonic acid accompanying a change of hydrogen ion concentration from $2.92 \times 10^{-8}\text{N}$ to $5.65 \times 10^{-8}\text{N}$ would accordingly be only $\frac{14.3}{24.8} = 58$ per cent or roughly a little more than half the real change.

Again, if the hemoglobin did not vary in affinity for base the increase of the hydrogen ion concentration accompanying an increase of 24.8 per cent by volume in the combined carbonic acid would be more than 170 per cent of the real change. In other words the hydrogen ion concentration would have risen to more than $7.5 \times 10^{-8}\text{N}$.

Let us take two more conditions of equilibrium:

O ₂	CO ₂	Oxygen absorption.	[BHb]	[HHb]	[BHbO ₂]	[HHbO ₂]	[BHCO ₂]	[H] ⁺
mm.	mm.	per cent	vol. per cent	vol. per cent	vol. per cent	vol. per cent	vol. per cent	
0	40	0	6.3	11.7			54.3	$4.30 \times 10^{-8}\text{N}$
140	40	100			14.6	3.4	48.8	$4.62 \times 10^{-8}\text{N}$

From these data we find that when oxygenated blood with the tension of carbon dioxide of 20 mm. is converted into reduced blood with a carbon dioxide tension of 40 mm. the hydrogen ion concentration changes from $2.92 \times 10^{-8}\text{N}$ to $4.30 \times 10^{-8}\text{N}$. At the same time the carbonic acid increases by an amount equal to $54.3 - 37.2 = 17.1$ per cent by volume. The base yielded by the hemoglobin radical is $15.7 - 6.3 = 9.4$, and that yielded by ordinary buffer action, accordingly, $17.1 - 9.4 = 7.7$ per cent by volume.

Again, passing from oxygenated blood with a tension of carbon dioxide of 40 mm. to reduced blood with a tension of carbon dioxide of 60 mm. involves a change of hydrogen ion concentration from $4.62 \times 10^{-8}\text{N}$ to $5.65 \times 10^{-8}\text{N}$; the increase of combined carbonic acid is $62.0 - 48.8 = 13.2$ per cent by volume; the base yielded by the hemoglobin radical is $14.6 - 5.2 = 9.4$ per cent by volume, and that yielded by ordinary buffer action only $13.2 - 9.4 = 3.8$ per cent by volume. In this last case, if the peculiar function of the hemoglobin were eliminated, the change in absorption of carbonic acid for the given change of hydrogen ion concentration would be only $\frac{3.8}{13.2} = 29$ per cent of its real value.

The change in the hydrogen ion concentration for the given change in combined carbonic acid, however, would be at least 350 per cent of the real value and the concentration of the hydrogen ion would rise to more than $8 \times 10^{-8}N$.

Since data defining all the conditions for tensions of oxygen corresponding to the physiological range are not at hand, this question can hardly be further analyzed.

From the above data, however, it is evident that the type of change which involves a very great absorption of carbon dioxide for a very small change in concentration of the hydrogen ion and, of course, a very small change in hydrogen ion concentration for a very large change in carbonic acid absorption is particularly marked for tensions of carbonic acid which are physiologically important. Moreover the shape of Barcroft's curves affords at least equally good evidence that it is also predominant within ranges of oxygen tension corresponding to those which exist in arterial and venous blood.

If this phenomenon is of the first importance as a means of increasing the efficiency with which oxygen and carbonic acid are carried to and from the tissues, it appears to be no less important as a factor in regulating the hydrogen ion concentration of the blood. This has been pointed out by Christiansen, Douglas, and Haldane (3), by Hasselbalch (6), and others.

The possibility of such a process as this, depending upon a cyclic variation in the ionization constant of an acid was completely, though I hope pardonably, overlooked in my original description of the acid-base equilibrium of the organism (4). And a claim that all the different types of physicochemical phenomena which are involved in the process had been at least considered (5) must accordingly now be withdrawn. I think there can be little doubt, however, that this is the only example of such a chemical mechanism which has ever come to light.

This leads to a further physiological consideration. It has long been an open secret that it was impossible theoretically to account for the quantity of carbonic acid which escapes from the blood in the lung. The paper of Christiansen, Douglas, and Haldane went far to overcome the difficulty, but the fact of the very slight variation of hydrogen ion concentration, which was the kernel of the whole question, remained or at least was insufficiently ex-

plained. In the light of the present considerations I believe that the difficulty probably disappears.

One of the most puzzling phenomena attending changes of the oxygen and carbon dioxide content of the blood is the increase in the volume of the red cells, accompanied by a passage of acid radicals from the plasma into the corpuscles, when carbonic acid tension increases. The process is of course reversed by a decrease of carbon dioxide tension. Some years ago Spiro and I succeeded in producing somewhat similar phenomena in much simpler systems (16). As a result of these experiments we reached the conclusion that the process depends, in the main, upon the fact that as carbonic acid concentration increases there is a shift of base from proteins to carbonic acid. If this explanation is true, it is natural to suppose that more base will be given up within the corpuscles than in the plasma, since the concentration of proteins in the corpuscles is much greater. As a result the osmotic pressure will increase more, and the hydrogen ion concentration less, in the corpuscles than in the plasma; water will pass into the corpuscles to reestablish the osmotic equilibrium, and acid to reestablish the acid-base equilibrium between the cells and the solution in which they are suspended.

Evidently this process helps to explain the escape of carbonic acid from the plasma without a change of the hydrogen ion concentration of the magnitude that would otherwise be necessary. In this way it was possible to show that the plasma proteins have no great share in controlling the reaction of the blood (17). But this consideration, while valid, obviates one difficulty only to raise another. This new difficulty, however, concerns the affinity of hemoglobin for base. But, in view of the basic character of the protein globin, I was at that time disposed to think that it was hard to account for so great a fluctuation in the amount of base combined with hemoglobin as was clearly indicated by even the roughest estimates of the magnitude of the process. Variation in the affinity of hemoglobin for base puts the whole question in a different light, and Hasselbalch and Warburg, who hold the same view of the general nature of the process, have pointed out that this goes far to explain the phenomenon (18). The theory developed in the present paper permits an estimate of the quantitative variations involved.

Let us turn once more to the change from blood saturated with air containing carbon dioxide at a tension of 40 mm. to the system in equilibrium with an atmosphere free from oxygen, in which the tension of carbon dioxide is 60 mm. There is involved an increase in combined carbonic acid amounting to 13.2 per cent by volume. Of this nearly three-quarters will come from the hypothetical hematin radical of variable affinity and, of the remaining one-fourth, the buffer action of globin and other substances within the corpuscles must account for much the greater share, leaving probably not more than 1 per cent by volume as the share of the buffer substances of the plasma. But, since the volume of the corpuscles is less than that of the plasma, the actual changes in concentration will be even more disparate.

For every molecule of bicarbonate thus added there must be a net increase of at least 0.5 molecule or ion in solution. Accordingly there must be a large increase in the osmotic pressure of the corpuscles and a very small increase in the osmotic pressure of the plasma. Similarly, there must be a relatively large increase in the hydrogen ion concentration of the plasma, or at least a tendency in this direction, and a very small increase in the hydrogen ion concentration of the corpuscles, because the increase in the hydrogen ion concentration is checked by the increase of bicarbonate according to the implications of the familiar equation

$$[\text{H}^+] = k \frac{[\text{CO}_2]}{[\text{BHCO}_3]}$$

Taking these arguments into account it seems safe to say that the main features of the phenomenon are probably known.

In conclusion it needs to be said that the validity of the somewhat difficult, and no doubt quantitatively provisional, theoretical discussions of the present paper is not necessary for the validity of the conclusions. The influence of carbon dioxide on oxygen tension is a well established fact (1, 2). So is the influence of oxygen on carbon dioxide tension (3), and from these facts the influence upon the hydrogen ion concentration and the acid-base equilibrium follow necessarily (4, 5). Given these three postulates the other phenomena may be deduced. What is uncertain is the exact magnitude of these; their existence is, I believe, no longer open to question. It is important not to attach too much signif-

icance to estimates, necessarily provisional, of these magnitudes and I hope before long to be able to report results of a research, recently resumed after interruption by the war, which will permit a revision of the estimates of this paper.

SUMMARY.

This paper seeks to explain the interaction between oxygen and carbonic acid in blood by means of the theory of acid-base equilibrium.

The isohydric change from fully reduced to fully oxygenated blood; the transfer of base from carbonic acid to hemoglobin, which is the main feature of this process; and the change of strength as acid of a portion of the hemoglobin molecule, which is its cause, are discussed. It is shown that all these phenomena can be explained by the assumption that a certain acid radical of the hemoglobin molecule has, for reduced hemoglobin and oxyhemoglobin respectively, the following values:

$$k_R = 2.3 \times 10^{-8}$$

$$k_O = 2.0 \times 10^{-7}$$

From this consideration it follows that the salt of the acid radical in question must have a greater affinity for oxygen than the free acid. If the mass law constants of the reaction of salt and acid with oxygen were k_s and k_1 respectively, it should be approximately true that

$$\frac{k_A}{k_s} = \frac{k_O}{k_R} = 9$$

In the light of these considerations the equilibrium between protein acid radicals and base in blood is examined.

The bearing of these considerations upon Hill's equation for the equilibrium between hemoglobin and oxygen is considered, but at this point the difficulties are only partially overcome.

The union of hemoglobin as a base with acids, and especially with carbonic acid in blood, is discussed.

Finally, the bearing of these considerations upon the physiological processes, both the homogenous reactions within the corpuscles and the plasma, and also the heterogenous exchanges between corpuscles and plasma, is investigated.

BIBLIOGRAPHY.

1. Barcroft, J., *The respiratory function of the blood*, Cambridge, 1914.
2. Bohr, C., Hasselbalch, K., and Krogh, A., *Skand. arch. Physiol.*, 1904, xvi, 402.
3. Christiansen, J., Douglas, C. G., and Haldane, J. S., *J. Physiol.*, 1914, xlviii, 244.
4. Henderson, L. J., *Am. J. Physiol.*, 1908, xxi, 173.
5. Henderson, L. J., *Ergebn. Physiol.*, 1909, viii, 254.
6. Hasselbalch, K., *Biochem. Z.*, 1916, lxxviii, 112.
7. Bohr, C., in *Nagel's Handb. der Physiologie des Menschen*, Braunschweig, 1909, i, 57.
8. Bohr, C., *Centr. Physiol.*, 1903-04, xvii, 713.
9. Hasselbalch, K. A., and Lundsgaard, C., *Biochem. Z.*, 1912, xxxviii, 88.
10. Parsons, T. R., *J. Physiol.*, 1919-20, liii, 42.
11. Bohr, C., *Festschrift für Ludwig*, Leipzig, 1887, 164.
12. Sörensen, S. P. L., and others, *Compt. rend. trav. Lab. Carlsberg*, 1917, xii, 1.
13. Henderson, L. J., Cohn, E. J., Catheart, P. H., Wachman, J. D., and Fenn, W. O., *J. Gen. Physiol.*, 1919-20, i, 459.
14. Henderson, L. J., *Am. J. Physiol.*, 1908, xxi, 169.
15. Robertson, T. B., *J. Biol. Chem.*, 1909-10, vii, 351.
16. Spiro, K., and Henderson, L. J., *Biochem. Z.*, 1908, xv, 114.
17. Henderson, L. J., *J. Biol. Chem.*, 1909, vii, 29.
18. Hasselbalch, K. A., and Warburg, E. J., *Biochem. Z.*, 1918, lxxxvi, 410.

FERMENTATION OF FRUCTOSE BY LACTOBACILLUS PENTOACETICUS, N. SP.*

BY W. H. PETERSON AND E. B. FRED.

(From the Departments of Agricultural Chemistry and Agricultural Bacteriology, University of Wisconsin, Madison.)

(Received for publication, January 20, 1920.)

The fermentation of fructose by the pentose fermenters which have been called *Lactobacillus pentoaceticus*, n. sp., presents some very interesting and unique aspects; viz., the production of mannitol and the subsequent fermentation of this mannitol into acetic and lactic acids.

The production of mannitol by the fermentation of fructose has been observed by several investigators and has led these investigators to designate the fermenting organisms as "mannite bacteria," i.e., mannitol-forming bacteria.

Strecker was perhaps the first to obtain mannitol by a fermentation process. He allowed a mixture of hydrolyzed cane sugar, cheese, sour milk, and calcium carbonate to undergo spontaneous fermentation for 2 or 3 months. From the fermented mass he isolated mannitol in considerable quantities; e.g., 1 pound of pure mannitol from the fermentation of 10 pounds of sugar. Dragendorff repeated the earlier work of Strecker and obtained a good yield of mannitol in his first fermentation, but a second experiment failed to show a trace of mannitol.

In the course of a discussion on the causes and conditions of lactic acid production Pasteur pointed out that besides lactic acid, other products, such as alcohol, butyric acid, and mannitol, were formed. He noted that great variations occurred in the amount of mannitol produced.

Marcano in the making of rum from the sugar-cane of the West Indies recognized mannitol as a product of the fermentation.

In all this early work no attempt was made to use pure cultures of bacteria or pure chemical substances.

* This work was in part supported by a grant from the special research fund of the University of Wisconsin. Published with the permission of the Director of the Wisconsin Agricultural Experiment Station.

Gayon and Dubourg made a very careful study of the formation of mannitol in fermenting solutions. From a white wine they isolated an organism whose power of fermentation they tested on various sugars and related compounds. From fructose, mannitol was obtained in considerable quantity. Sucrose was readily fermented but gave no mannitol. On the other hand, when sucrose was first hydrolyzed into its two components glucose and fructose and then fermented, mannitol was formed. From this evidence Gayon and Dubourg concluded that sucrose was fermented directly by the bacteria and not inverted before fermentation, as is usually considered to be the case.

In an extensive study of the mannitic fermentation of wine Müller-Thurgau and Osterwalder isolated a number of organisms that produced mannitol from fructose. One of these, *Bacterium mannitopæum*, they report was able to ferment sucrose with the formation of mannitol. In two experiments crystals of mannitol were observed, but the amount formed was apparently too small to determine quantitatively as no separation of the crystals was made. Aside from these two experiments with *Bacterium mannitopæum*, no report has been found in the literature of mannitol formation directly from sucrose by means of a pure culture of bacteria.

Mannitol is frequently used as a source of carbon in the cultivation of bacteria. The ability of numerous organisms to break down mannitol is thus well established. The mannitol-forming bacteria as a group do not seem to possess this power. The organisms isolated and studied by Gayon and Dubourg, and by Müller-Thurgau and Osterwalder failed to grow on a medium in which fermentable sugars were replaced by mannitol.

Laborde isolated three organisms from wine which seemed to have the power of forming mannitol from fructose and later destroying the mannitol. He analyzed the cultures at two successive times in the course of the fermentation and obtained less mannitol in the second analysis than he had found 2 months earlier. His paper gives no data concerning the products formed from the mannitol.

All the mannitol-forming bacteria studied by the above investigators have been isolated from various kinds of wine. The organisms which are described in this and in our preceding papers (1919, 1920) have been isolated from different sources, such as manure, silage, and soil, and have a more general distribution in nature than the so called "mannite bacteria." *They are related to these bacteria by their ability to form mannitol from fructose; but a more conspicuous and characteristic property is their power to bring about a very rapid and complete fermentation of the pentose sugars xylose and arabinose.* It is probable that the general occurrence of the pentose fermenters is closely correlated with the

equally wide distribution of pentose-yielding compounds and that these bacteria play an important part in the decomposition of these plant compounds.

As will be shown later in this paper, the pentose fermenters produce mannitol in such quantities that it can be easily isolated, identified, and subsequently fermented by the organism that produced it.

The products formed by fermenting the mannitol have also been determined. The origin of this mannitol must be due to a reduction of fructose as a result of conditions incident to the fermentation process. On the basis of the experimental facts developed in this paper and the very complete data of Gayon and Dubourg and other investigators, it is suggested that the general line of reaction by which fructose is broken down and mannitol produced may be represented by the following equations.

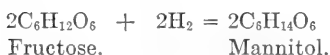

If in the production of acetic and lactic acids from fructose nascent hydrogen is produced, this may then react with another fructose molecule and reduce it to mannitol. This theory does not regard mannitol as an intermediate but a coincident product in the formation of acetic and lactic acids. There is considerable evidence to support this theory in the papers of Gayon and Dubourg, Laborde, and Müller-Thurgau and Osterwalder. Carbon dioxide was always formed by their bacteria and malic acid was fermented to lactic acid and carbon dioxide by some of these organisms. Mannitol was found in quantities approximating what is required by this theory. Their organisms did not ferment mannitol and hence the theoretical amount of mannitol might accumulate. The data of Gayon and Dubourg, and Laborde are sufficiently complete to balance against that required by the above theory.

	Found.		Required.
	Gayon and Dubourg.	Laborde.	
	<i>per cent</i>	<i>per cent</i>	<i>per cent</i>
Acetic acid.....	14.0	10.0	11.1
Lactic ".....	12.5	14.3	16.7
Mannitol.....	66.0	63.0	67.4
Carbon dioxide.....	9.0		8.2
Succinic acid.....	0.25		
Glycerol.....	0.60		

When we consider the difficulties and errors involved in the determination of some of these compounds, especially lactic acid, for which all methods probably give too low results, it is seen that fair agreement exists between the found and calculated values. The small amounts of glycerol and succinic acid found could also be accounted for as originating from the malic acid.

That the above theory does not seem to fit all the facts in respect to each mannitol-producing organism that has been isolated will be observed by a careful examination of the published data; but as a working hypothesis it may well serve for a time. The correlation of the above theory with the data obtained in the fermentation of fructose by the pentose fermenters will be considered in the experimental part of this paper.

EXPERIMENTAL.

In the fermentation of fructose, approximately 2 per cent solutions were used. The sugar was dissolved in a water extract of compressed yeast sterilized for 30 minutes and sterilized bromocresol purple added at the time of inoculation. The acids formed during the fermentation were neutralized with sterilized normal alkali whenever a decided acid reaction was indicated by the bromocresol purple. Controls, treated as above but not inoculated, were always run parallel with the fermenting culture solutions. The values obtained from the controls have been deducted in calculating the data given in the tables. At the end of the fermentation period the cultures were analyzed for acetic and lactic acids by the steam distillation and extraction methods employed in our previous work (1919). At the same time the

mannitol was determined either on an aliquot of the culture or, in a few cases, upon the ether-extracted residue. The procedure in general was that previously used by Gayon and Dubourg and others. The sample was first concentrated on the steam bath, filtered from any precipitate, and the filtrate evaporated to dryness on clean sand. This was then successively extracted with small portions of boiling 80 per cent alcohol until completely exhausted of mannitol. About ten extractions were usually made. In some of the later determinations an extraction apparatus similar in design to the Kutscher-Steudel extraction apparatus for non-volatile acids was used. The lower end of the tube was immersed in an oil bath kept at a temperature just below the boiling point of the alcohol. The extraction could thus be carried on continuously for any desired length of time. Usually the dried residue was extracted for about 10 hours. After the alcohol extract was filtered, it was concentrated to a thick syrup and set aside in the refrigerator for 1 or 2 days. Crystals usually formed over night, but in some cases crystallization was not complete until after 2 or 3 days. The crop of crystals was freed from the mother liquor by filtering through a hardened filter with the aid of suction, was washed with alcohol and finally with ether, then dried, and weighed. As thus obtained the mannitol crystals were usually snow-white. The mother liquor and washings were again concentrated to a thick syrup, placed in the refrigerator, and kept there until a second crop of crystals had separated out. Usually 2 or 3 days were required. Additional crystallizations were made until no more crystals formed even after standing in the ice box for 6 or 8 days. With the improved method of extraction, the recovery of a known quantity of mannitol from yeast water and the control solution was from 92 to 95 per cent.

The unfermented fructose in the culture was also determined but in no case did this exceed 0.1 gm. and in most of the cultures merely a trace of reducing sugar was found. As the cultures contained about 2 gm. of fructose when inoculated, it is clear that practically all the fructose had disappeared at this time.

The results of the analyses are given in Table I and disclose several interesting points:

The quantities of acetic acid and lactic acid are nearly equal, but in general with lactic slightly in excess of acetic.

The quantity of mannitol is greater in the young cultures than in the older ones. This is very clearly shown in the 22 and 51 day cultures of Nos. 41-11 and 118-8. These four cultures were made up from the same batch of medium and were grown under the same conditions so that the results obtained furnish a good basis for comparison. The mannitol has decreased

TABLE I.

Products Formed from the Fermentation of Fructose in 100 Cc. of Culture.

Time.	Culture No.	Weight of fructose.	Acetic acid.	Lactic acid.	Mannitol.	Ratio acetic: lactic.
<i>days</i>		<i>gm.</i>	<i>gm.</i>	<i>gm.</i>	<i>gm.</i>	
16	41-11	1.70	0.512	0.329	0.573	100 : 105
22	41-11	1.70	0.320	0.340	0.441	100 : 107
51	41-11	1.70	0.436	0.549	0.323	100 : 126
16	118-8	1.70	0.311	0.338	0.533	100 : 108
22	118-8	1.70	0.293	0.151	0.350*	
51	118-8	1.70	0.444	0.539	Trace.	100 : 125
31	41-11	1.70	0.360	0.333	0.443†	110 : 92
31	55-9	1.70	0.353	0.328	0.443†	100 : 93
31	69-19	1.70	0.288	0.347	0.443†	100 : 120
31	69-30	1.70	0.331	0.290	0.443†	100 : 90
31	118-5	1.70	0.312	0.347	0.443†	100 : 111
31	118-8	1.70	0.326	0.335	0.443†	100 : 102
20	55-9	1.70			0.629†	
20	69-19	1.70			0.719†	

* Low result is probably due to bone-blackening the alcohol solution before crystallizing.

† This figure was obtained by the analysis of the combined Cultures 41-11 to 118-8 inclusive.

markedly in both cultures, while the acetic and lactic acids have just as markedly increased. The fructose present in parallel cultures analyzed at the end of 22 days was less than 0.1 gm., so that the increase in the acids could not have come from unfermented fructose. It must therefore have originated from the fermentation of the mannitol. The mannitol is formed very early in the fermentation of the fructose and then is itself slowly attacked by the organisms. Further evidence on this point will be presented later.

The identification of mannitol is based principally upon its characteristic crystalline form and upon its melting point. Many determinations, made on the crystals isolated, gave figures ranging from 163–164°C. (uncorrected). A sample of commercial mannitol gave a value of 164°C. (uncorrected). The melting point of pure mannitol is given by various authorities as 166.05°C. (Braham). The crystalline appearance, melting point, and fermentability clearly establish the identity of the compound.

In the preceding experiments no attempt was made to determine the gaseous products involved. After some preliminary tests it was found that carbon dioxide was produced in considerable quantities. A number of experiments were therefore carried out in which the carbon dioxide was determined and a more complete accounting for the fructose fermented was obtained.

In these experiments the fermentation flask A (Fig. 1) was closed with a two-hole rubber stopper. Through one hole was passed a short glass tube B. The upper end was closed by means of a short piece of rubber tubing and a screw pinch-cock. The rubber tube was plugged with cotton and wrapped with tin-foil. When it became necessary to add alkali to the fermenting solution the tin-foil cap and cotton were removed, the pinch-cock was opened, and sterilized alkali run in from a sterilized, finely calibrated pipette.

Through the second hole in the rubber stopper a bent tube C made from a 25 cc. pipette was passed. The delivery end of this tube passed through a two-hole stopper into a small bottle D containing strong potassium hydroxide. A guard tube E containing soda lime was joined to the potassium hydroxide bottle to prevent absorption of carbon dioxide from the air. As a further precaution against leaks the rubber stoppers were coated with a mixture of beeswax and paraffin. This apparatus permitted the gas evolved in the fermentation flask to pass over into the bottle containing the potassium hydroxide where the carbon dioxide was absorbed and at the same time permitted the escape of the air contained in the bottle at the beginning of the fermentation. The bulb of the connecting tube prevented the potassium hydroxide from being sucked back into the fermentation flask, when the temperature changed or when fermentation ceased. At the end of the fermentation period, a small glass tube was passed through

B to the bottom of flask A and the greater part of the CO_2 remaining in flask A was aspirated over into D by means of a current of CO_2 -free air. The carbon dioxide in the culture solution and in the potassium hydroxide was determined by means of Van

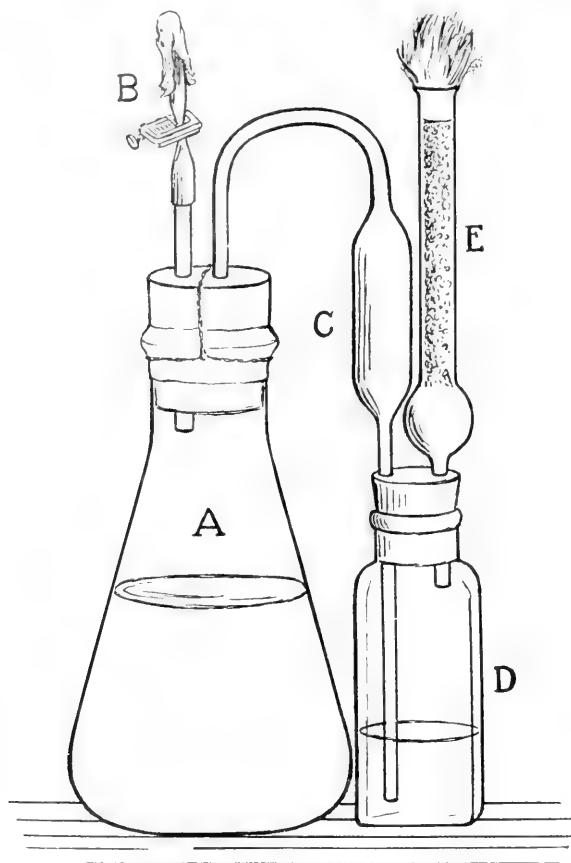

FIG. 1. Fermentation flask with CO_2 absorption bottle.

Slyke's apparatus for determining carbon dioxide in blood and carbonate solutions. The data obtained are given in Table II.

From the results of Table II it is seen that about 85 per cent of the fermented fructose is accounted for by the products acetic acid, lactic acid, mannitol, and carbon dioxide. The iodoform

test for alcohol was negative and the result by the potassium dichromate method for the quantitative determination of alcohol showed little more volatile acid than the reagents alone. The data obtained from the analyses of the *4 day* cultures of No. 118-8 bring out very clearly the rapidity with which fructose disappears from the culture solution; less than 0.1 gm. of fructose remained unfermented. About one-half the sugar consumed had been broken down into acetic and lactic acids and carbon dioxide. A somewhat smaller proportion of the sugar had been converted into the mannitol. The evidence indicates that the mannitol is not attacked until the more easily fermented fructose has been consumed. As will be shown later the slow rate of fermentation of mannitol lends support to this view.

TABLE II.

Total Fermentation Products Formed and Per Cent of Fructose Accounted for by the Products.

Time.	Culture No.	Weight of fructose fermented.	Acetic acid.	Lactic acid.	Mannitol.	Carbon dioxide.	Fructose accounted for by products.
<i>days</i>		<i>gm.</i>	<i>gm.</i>	<i>gm.</i>	<i>gm.</i>	<i>gm.</i>	<i>per cent</i>
17	41-11	1.70	0.326	0.365	0.570	0.215	87
17	118-8	1.60	0.266	0.284	0.452	0.220	77
4	118-8	1.60	0.239	0.260	0.764	0.176	90
58	118-8	1.60	0.298	0.180	0.450	0.273	75

Due to the improved means of extraction already described, the values for mannitol obtained here are higher than in the earlier experiments.

From the data in Table II the molecular proportions of the several products have been calculated and appear in Table III.

The molecular ratios are in fair harmony with the reaction previously proposed.

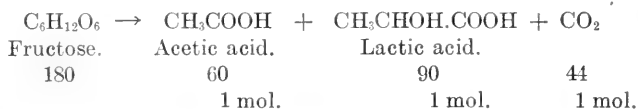

The only serious departure is in the case of lactic acid. This is not unexpected since all the experimental errors tend to give a low value for lactic acid.

The possibility is always present that the lactic acid formed from the fructose may in turn be fermented subsequent to the fermentation of the fructose itself. This possibility is strongly indicated by the data obtained from the analysis of the 58 day culture. The data obtained from the fermentation of malic acid and old cultures of mannitol lend considerable support to this possibility. Kayser described a type of fermentation in which acetic acid and lactic acid were produced; but he believed that when fermentation was continued for some time the lactic acid was almost completely converted into acetic acid.

TABLE III.

Molecular Relations of the Fermentation Products of Fructose.

	Culture 41-11.			Culture 118-8.		
	Acetic acid.	Lactic acid.	CO ₂	Acetic acid.	Lactic acid.	CO ₂
Weights divided by molecular weights.....	0.051*	0.041	0.050	0.044*	0.031	0.050
Molecules.....	1.0	0.8	1.0	1.0	0.7	1.1
Weights divided by molecular weights.....				0.040†	0.029	0.040
Molecules.....				1.0	0.7	1.0
Weights divided by molecular weights.....				0.050‡	0.020	0.062
Molecules.....				1.0	0.4	1.5

* After 17 days fermentation.

† " 4 "

‡ Same culture as (†) analyzed 54 days later.

Fermentation of Malic Acid.

In order to test the hypothesis that malic acid may be an intermediate product in the fermentation of fructose by the pentose fermenters the fermentability of malic acid was demonstrated experimentally and the products formed were determined. In Series I a solution of malic acid was neutralized with sodium hydroxide and then made up with yeast water to a volume equivalent to 2 per cent calculated as malic acid. These solutions were inoculated with Cultures 41-11 and 118-8, and sterilized bromocresol purple was added. Fermentation of the sodium malate

was shown by the solutions becoming alkaline to the bromocresol purple. This change indicates the decarboxylation of the salt, the formation of sodium bicarbonate, and the production of a mono-basic acid instead of a di-basic acid. The alkalinity thus developed soon checks the activity of the organisms. The cultures were therefore neutralized with 0.1 N malic acid at intervals of about 2 days each. That malic acid ferments very rapidly may be seen from the curve of acid production given in Fig. 2 at the end of this paper. The rate of acid production was somewhat slower at first than was the case with fructose, but soon became faster and continued at this very rapid rate to the end of the

TABLE IV.

Fermentation of Malic Acid Salts Calculated for 100 Cc. of Culture.

Culture No.	Length of fermentation.	Weight of malic acid.	Volatile acid as acetic.	Non-volatile acid as lactic.	Carbon dioxide.
	<i>days</i>	<i>gm.</i>	<i>gm.</i>	<i>gm.</i>	<i>gm.</i>
Series I.					
41-11	30	3.140*	0.146	0.804	Undetermined.
118-8	30	3.140*	0.176	0.734	"
Series II.					
41-11	16	0.684*	0.078	0.342	0.260
118-8	16	0.684*	0.070	0.268	0.216
Series III.					
41-11	23	2.000†	0.043	0.113	0.084
118-8	23	2.000†	0.059	0.111	0.102

* As the neutral sodium salt.

† " " " calcium "

fermentation period. The malic acid thus fulfills one of the requirements for an intermediate fermentation product; *viz.*, that the intermediate product must ferment as fast as or faster than the compound from which it is formed. The results of the malic fermentation are given in Table IV.

In Series II and III the carbon dioxide evolved was determined. Except in Series II, where only small amounts of malic acid were used, large amounts of malate remained unfermented. In Series I fermentation ceased because of the high alkalinity developed, caused by the inevitable accumulation of sodium bicarbonate. In Series III the alkalinity must be due to calcium

carbonate which is not injurious to the growth of the organisms. Some other factor must therefore have operated to check the fermentation in this case.

When the cultures were analyzed it was found that an appreciable amount of volatile acid had been developed. This acid was later identified by its Duclaux distilling constant as almost entirely acetic. The quantity of carbon dioxide found is greater than that required on the assumption that one molecule of carbon dioxide is formed for one molecule of lactic acid. The production of acetic acid and an excess of carbon dioxide, therefore, indicates that some change other than the simple malic to lactic takes place. The origin of the acetic acid and the excess of carbon dioxide might be explained on the assumption that a secondary fermentation of the lactic acid follows the primary malic to lactic fermentation. On this hypothesis the breaking down of the malic acid may be represented schematically.

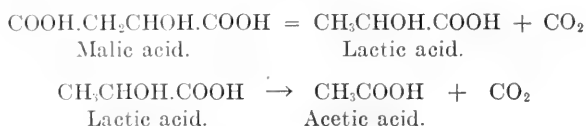

This is only a working hypothesis and is subject to more complete experimental data.

The possibility of organic acids other than malic being intermediate products in the fermentation of fructose was tested, but none was found that could be fermented. The malic acid cultures were tested for alcohol, but none was found.

Fermentation of Mannitol.

In the course of a study on the pentose fermenters it was found that mannitol was broken down with the formation of acetic and lactic acids. An experiment was therefore set up to test the fermentability of the mannitol, formed from fructose, by the same bacteria that produced it. For this purpose 40 gm. of fructose were dissolved in 2 liters of water and 100 cc. portions placed in twenty flasks. Ten flasks were inoculated with Culture 41-11 and ten with Culture 118-8. The mannitol produced from 30 of the 40 gm. of fructose was isolated as

previously described and amounted to 5.97 gm. Culture solutions containing 2 per cent of this mannitol were then inoculated with the six pentose fermenters previously studied and the acid production was roughly measured by the addition of normal alkali from time to time. After varying lengths of time the cultures were analyzed for acetic and lactic acids. The data obtained together with that from the fermentation of commercial mannitol are given in Table V.

TABLE V.

Acid Production from Fermentation of Cultures Containing 2 Per Cent Mannitol. Calculated for 100 Cc. of Culture.

Time.	Culture No.	Mannitol used.	Volatile acid as acetic.	Non-volatile acid as lactic.	Ratio acetic: lactic.
<i>days</i>			<i>gm.</i>	<i>gm.</i>	
18	41-11	Merek's C.P.	0.185	0.221	100:120
18	55-9	"	0.190	0.232	100:123
18	69-19	"	0.146	0.230	100:158
18	69-30	"	0.151	0.184	100:122
18	118-5	"	0.155	0.175	100:113
18	118-8	"	0.137	0.194	100:142
66	41-11	"	0.560	0.788	100:141
37	55-9	"	0.325	0.522	100:160
66	69-19	"	0.317	0.497	100:156
60	118-8	"	0.266	0.360	100:135
42	118-8	From fructose.	0.415	0.499	100:120
87	41-11	" "	0.798	0.306	100: 38
87	55-9	" "	0.544	0.228	100: 42
38	69-19	" "	0.352	0.507	100:144
38	69-30	" "	0.239	0.305	100:128
38	118-5	" "	0.224	0.282	100:126

An examination of the data shows a slow but steady fermentation. After 18 days the acids formed represent about 20 per cent of the initial mannitol and at the end of 66 days this has risen to as high as 67 per cent in the case of Culture 41-11. Only slight differences in the vigor of the cultures are apparent during the early stages of the fermentation, but at the end more marked differences appear. Cultures 41-11, 55-9, and 69-19 show conspicuous activity in the fermentation of both mannitol and fructose. The ratio of acetic to lactic runs much the same throughout the period of fermentation except in the two 87 day

Cultures 41-11 and 55-9, where a very pronounced change in the ratio has taken place. Apparently in these two cases some of the lactic acid has been broken down into acetic acid. This possibility was also pointed out in connection with the fermentation of fructose, Tables II and III, malic acid, Table IV, and in the discussion of Kayser's work on the fermentation of glucose.

The commercial c. p. mannitol and the mannitol from fructose are fermented in exactly the same manner. The rate of fermentation, the products formed, and the ratio of the two acids are alike in both cases. Biologically, as well as chemically, the mannitol from fructose appears to be the same compound as the commercial product.

Identification of the Volatile Acids.

The volatile acids formed from the fermentation of fructose, mannitol produced from fructose, Merck's c. p. mannitol, and malic acid were subjected to a Duclaux distillation and their distilling constants determined. The data obtained in a few representative cases are given in Table VI.

It is evident from this table that the volatile acid formed by the fermentation of fructose mannitol, whether the commercial or biological product, and of malic acid is practically all acetic acid. The agreement between the distilling constants obtained and that required for acetic is very good. In a few representative cases the barium content of the acids used in the Duclaux distillation was determined subsequent to this distillation, and serves further to identify the volatile acid as nearly pure acetic. The data are given in Table VII.

Identification of the Non-Volatile Acid.

The non-volatile acid was identified as lactic acid by its barium salt and zinc salt. The free acid was extracted by the usual ether extraction method and titrated with barium hydroxide; from the barium salts the zinc salts were made. The zinc lactate crystals thus obtained had the crystalline appearance of the inactive or racemic type (Dox and Neidig). The determination of the water of crystallization showed that three molecules of water were present for each molecule of salt. The data obtained are given in Table VIII.

TABLE VI.

Distilling Constants of the Volatile Acids Obtained by Duclaux Method.

Source of acid.	Culture No.	Fractions.									
		10 cc.	20 cc.	30 cc.	40 cc.	50 cc.	60 cc.	70 cc.	80 cc.	90 cc.	100 cc.
Fructose.....	41-11	7.1	15.8	24.3	33.1	42.2	51.8	62.0	73.0	85.2	100
“	118-8	7.1	16.4	24.8	33.5	42.6	52.1	62.3	73.3	85.5	100
Mannitol from fructose.....	69-19	7.5	15.5	24.0	32.7	41.9	51.6	62.0	73.0	85.0	100
Mannitol (Merck's c.p.)	41-11	7.4	15.3	24.0	32.2	41.6	51.3	61.5	72.5	85.2	100
Malic acid.....	41-11 and 118-8.	7.8	15.9	24.2	32.8	41.8	51.2	61.4	72.5	84.9	100
Duclaux constant for acetic acid....		7.4	15.2	23.4	32.0	40.9	50.5	60.6	71.9	84.4	100

TABLE VII.

Composition of the Barium Salts of the Volatile Acid.

Compo . . . ermented.	Culture No.	Barium salts of the volatile acid.	Barium sulfate equivalent.	
			Found.	Calculated for acetic acid.
			gm.	gm.
Fructose.....	118-8*	0.3854	0.3488	0.3521
“	118-8†	0.7566	0.6816	0.6913
Mannitol from fructose.....	41-11	0.3314	0.3030	0.3028
“ (Merck's c. p.).....	41-11	0.5748	0.5151	0.5234
Sodium malate.....	41-11 and 118-8.	0.3416	0.3048	0.3121

* Fermented 4 days.

† “ 58 “

TABLE VIII.

Water of Crystallization Contained in Zinc Lactate.

Source of salt.	Culture No.	Zinc lactate used.	Water lost.		Water in Zn (C ₂ H ₃ O ₂) ₂ + 3H ₂ O.
			gm.	per cent	
Fructose.....	118-8; 3 days old.	0.1472	0.0260	18.2	18.17
“	118-8, 12 days old.	0.1186	0.0208	17.6	18.17
Mannitol from fructose...	69-19	0.3022	0.0602	19.1	18.17
“ (Merck's c.p.)..	41-11	0.464	0.0824	17.8	18.17

In a few cases the non-volatile acid was examined for its barium content. After the ether extract was titrated with barium hydroxide, the solution of barium salts was evaporated to about 10 cc., made up to 100 cc. with 95 per cent alcohol, filtered from any precipitate, and an aliquot evaporated to dryness in a platinum dish. The salts were dehydrated by heating at 130°C. for several hours until constant weight was secured and then were converted into barium sulfate by burning off the salts in the presence of an excess of sulfuric acid.

From the data thus obtained it is apparent that the non-volatile acid is almost wholly lactic acid. No evidence of succinic or other acids was obtained. The slightly lower values found are

TABLE IX.

Lactic Acid Produced from Fructose and Its Related Compounds.

Compound fermented.	Culture No.	Weight of barium salts.	Weight of barium sulfate.	
			Found.	Calculated.
		gm.	gm.	gm.
Fructose.....	41-11	0.1630	0.1176	0.1206
".....	118-8	0.1640	0.1206	0.1214
Mannitol from fructose.....	118-5	0.3128	0.2238	0.2315
" (Merek's C.P.).....	118-8	0.5466	0.3900	0.4044
Malic acid.....	41-11	0.5386	0.3912	0.3985
" ".....	118-8	0.4862	0.3564	0.3597

due to the presence of a small amount of soluble organic matter, which was produced in the sterilization of the sugar and was weighed together with the barium lactate. The data are given in Table IX.

Rate of Acid Production.

As measured by the production of acid, fructose is very readily fermented by the pentose fermenters. The rate of acid production is not so fast as in the case of xylose and arabinose, but much faster than from glucose or galactose. The acidity of the fermenting solution, as indicated by the bromocresol purple, was neutralized from time to time by the addition of normal alkali. In this way the rate of development of acidity was noted. In Table X

are given the cc. of 0.1 N alkali or acid added at different times to cultures of fructose, commercial mannitol, mannitol obtained from fructose, and malic acid salts. From fructose approximately 40 cc. of 0.1 N acid were produced within 3 days, while from mannitol less than one-half this amount was produced. The fermentation in the case of fructose starts off quickly and is conspicuously faster for 15 to 20 days than in the case of mannitol. At the end of 23 days the quantity of acid produced from the two materials is nearly equal.

TABLE X.

*Rate of Acid Production from Fructose, Mannitol, and Sodium Malate.
Total 0.1 N Acid in 100 Cc. of Culture.*

Time.	Fermentation of fructose.				Fermentation of Merck's mannitol.				Fermentation of mannitol from fructose.				Fermentation of sodium malate.	
	Culture No.				Culture No.				Culture No.				Culture No.	
	41-11	55-9	69-19	118-8	41-11	55-9	69-19	118-8	41-11	55-9	69-19	118-8	41-11	118-8
<i>days</i>	cc.	cc.	cc.	cc.	cc.	cc.	cc.	cc.	cc.	cc.	cc.	cc.	cc.	cc.
3	40	36	31	40	25	12	5	9	6	7	10	6	10	10
6	65	65	53	67	58	27	31	22	22	23	26	20	50	50
10	80	80	68	76	70	45	51	37	37	40	42	30	90	90
18	90	88	80	85	85	69	64	53	61	73	63	53	145	145
27	103	101	92	96	106	91	75	66	82	102	84	75	180	180
38									100	128	106	100		
51									124	136				
63									147	142				

The conversion of fructose into mannitol is much more rapid than the breaking up of the latter into acetic and lactic acids and hence results in the accumulation of the mannitol. It is possible that no mannitol is attacked until most of the fructose has been used, because the latter compound is more readily utilized than the former. If the formation of mannitol is merely incidental to the strong reducing conditions set up in the fermentation of the fructose, then the mannitol would probably not be attacked until all the fructose had been consumed.

The rate of fermentation of the sodium malate, as judged from the production of acid, is equal to that of the fructose itself, and continues at this high rate throughout the fermentation period.

From the data in Table X four composite curves have been constructed to represent the average rate of acid production from the compounds fermented. The average of the figures for all the cultures at any given time has been taken to represent the acid produced at that particular time from each of the above four types of fermentation. Examination of Fig. 2 shows the general progress of the fermentation.

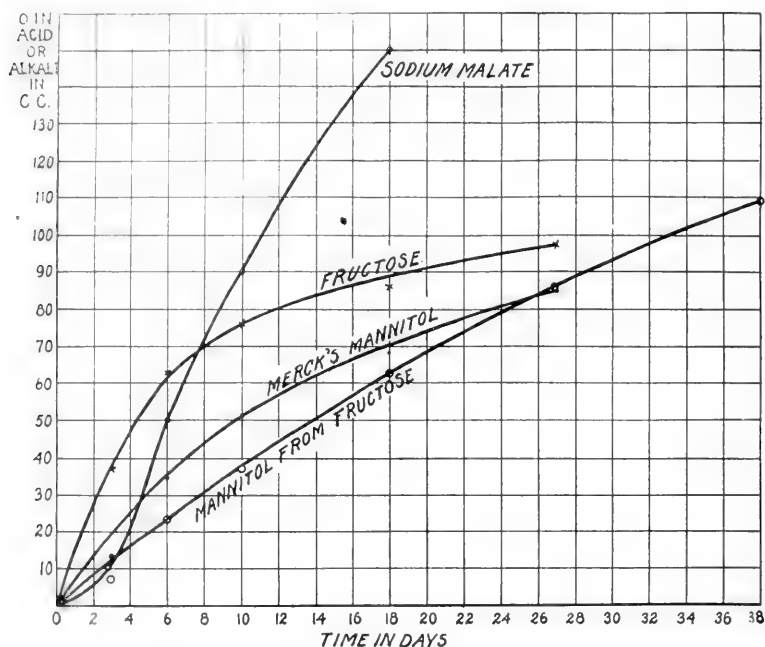

FIG. 2. Curves show average rate of acid production from different substances.

SUMMARY.

1. Fructose is readily fermented by *Lactobacillus pentoceticus*, *n. sp.*, with the production of acetic acid, lactic acid, mannitol, and carbon dioxide.

2. The mannitol accumulates in considerable quantities, representing 30 to 40 per cent of the fructose in the early stages of the fermentation. It has the crystalline appearance and the same

melting point, 164°C. (uncorrected), as the commercial c.p. product.

3. With the mannitol thus obtained a culture medium can be made and fermented by the same bacteria that produced the mannitol. The products formed are acetic acid and lactic acid. The fermentation of this mannitol is identical with that of commercial mannitol both with respect to the rate of fermentation and the end-products formed.

4. If the fructose solution is allowed to ferment for a long time the mannitol, which accumulates at first, undergoes slow fermentation; acetic and lactic acids are produced and eventually all the mannitol is destroyed.

5. The production of acetic and lactic acids from fructose is very rapid during the first days of the fermentation but slows up after 10 days. All the fructose disappears within 5 days. The fermentation of mannitol, on the other hand, is slow in starting but continues at about the same rate throughout the entire period. This difference in the fermentation of the two compounds is explained by assuming that the strong reducing conditions set up by the rapid production of acetic and lactic acids quickly convert the unfermented fructose into mannitol. Within a few days the fructose has thus been used up in the production of acetic acid, lactic acid, carbon dioxide, and mannitol. The slower fermentation which then ensues is really the decomposition of mannitol.

6. Sodium and calcium malate are fermented by the same organisms and yield chiefly lactic acid and carbon dioxide and a small quantity of acetic acid as the end-products.

7. On the basis of the above facts it is suggested that the main line of the fermentation process is the production of acetic acid, lactic acid, and carbon dioxide. It is assumed that malic acid is an intermediate compound in this process. The strong reducing conditions incident to this fermentation result in the reduction of a large part of the unfermented fructose to mannitol. This mannitol is subsequently attacked; and thus a second fermentation entirely different from that of fructose is set up.

8. Some evidence is presented to indicate that in a fermentation extending over a long period lactic acid itself is broken down to acetic acid by the pentose-fermenting bacteria.

BIBLIOGRAPHY.

- Braham, J. M., *J. Am. Chem. Soc.* 1919, xli, 1707.
- Dox, A. W., and Neidig, R. E., *Iowa Agric. Exp. Station, Research Bull.* 11, 1913.
- Dragendorff, G., *Arch. Pharm.*, 1879, ccxv, 47.
- Fred, E. B., Peterson, W. H., and Davenport, A., *J. Biol. Chem.*, 1919, xxxix, 347.
- Gayon, U., and Dubourg, E., *Ann. Inst. Pasteur*, 1894, viii, 108.
- Gayon, U., and Dubourg, E., *Ann. Inst. Pasteur*, 1901, xv, 527.
- Kayser, E., *Ann. Inst. Pasteur*, 1894, viii, 737.
- Laborde, J., *Compt. rend. Acad.*, 1904, cxxxviii, 228.
- Marcano, V., *Compt. rend. Acad.*, 1889, cviii, 955.
- Müller-Thurgau, H., *Landw. Jahrb. Schweiz*, 1907, xxi, 230.
- Müller-Thurgau, H., and Osterwalder, A., *Centr. Bakteriol., 2te Abt.*, 1912, xxxvi, 129.
- Müller-Thurgau, and Osterwalder, A., *Centr. Bakteriol., 2te Abt.*, 1917-18, xlviii, 1.
- Pasteur, L., *Compt. rend. Acad.*, 1857, xlv, 913.
- Peterson, W. H., and Fred, E. B., *J. Biol. Chem.*, 1920, xli, 181.
- Strecker, A., *Ann. chem. Pharm.*, 1854, xci, 80.
- Van Slyke, D. D., *J. Biol. Chem.*, 1917, xxx, 347.

NUTRITIVE FACTORS IN PLANT TISSUES.*

III. FURTHER OBSERVATION ON THE DISTRIBUTION OF WATER-SOLUBLE VITAMINE.

BY THOMAS B. OSBORNE AND LAFAYETTE B. MENDEL.

WITH THE COOPERATION OF ALFRED J. WAKEMAN.

(From the Laboratory of the Connecticut Agricultural Experiment Station
and the Sheffield Laboratory of Physiological Chemistry, Yale
University, New Haven.)

(Received for publication, January 17, 1920.)

In continuation of our earlier efforts to secure a more accurate comparison of the content of water-soluble vitamine of natural foods¹ the following method was employed with a series of plant products. Alfalfa, cabbage, clover, spinach, and timothy were dried in the manner already described.¹ Beet, carrot, and turnip roots were washed, cut into thin slices, desiccated in an air drier at 50–60°, and ground finely. Commercially canned tomatoes were dried at 60–70° and ground. Whole potato consisted of unpeeled potatoes boiled until tender, drained, mashed or sliced, dried at 60–70°, and ground. Peeled potato was prepared by paring raw potatoes as in domestic practise, boiling them until tender, mashing without draining, drying at 60–70°, and grinding. Furthermore, to compare the parts of the entire potato tuber with respect to the distribution of the water-soluble vitamine the potato peel was boiled in distilled water until tender, dried without draining, and ground.

These dried products were fed, apart from the rest of the food, to growing white rats receiving a diet adequate for them except

* The expenses of this investigation were shared by the Connecticut Agricultural Experiment Station and the Carnegie Institution of Washington, Washington.

¹ Osborne, T. B., and Mendel, L. B., *J. Biol. Chem.*, 1919, xxxvii, 187; xxxix, 29.

in respect to the lack of water-soluble vitamine. The basal food mixture consisted of:

	<i>per cent</i>
Meat residue.....	19.6
Salt mixture*.....	4.0
Starch.....	52.4
Butter fat.....	9.0
Lard.....	15.0

* For composition of salt mixture see Osborne, T. B., and Mendel, L. B., *J. Biol. Chem.*, 1919, xxxvii, 557.

The weekly food intake was determined except in a few instances where the animals spilled their ration and made the estimation inaccurate.

There are two ready methods of testing products for the presence of water-soluble vitamine. One consists in feeding the material to be investigated to animals that have declined on a diet deficient in this food factor. Such tests, however, will not demonstrate the *comparative* vitamine content of different foods. They are essentially restorative in character. If the outcome is positive in the sense of a renewal of nutritive well being, the test for the vitamine may be qualitatively successful. However, animals which have suffered a vitamine deficiency may be so badly malnourished or underfed that relatively excessive amounts of the vitamine-bearing food may be required to restore them to normal condition. In that event a failure to promote nutrition by the extract to be tested may be ascribed to the condition of the animal rather than the product. Comparisons of vitamine-bearing foods may not be reliable when they involve attempts to restore nutrition in animals that have suffered to a variable degree from unlike deficiencies.

The other method consists in feeding the supposed source of vitamine to animals which are normal in health and development, and observing whether the product offered supplies what is needed to promote normal growth when the diet affords an adequate supply of all essentials except that to be investigated. This procedure has been adopted in the present experiments. The basal ration included fat-soluble vitamine in the form of butter fat (9 per cent), but was devoid of water-soluble vitamine. Meat resi-

due, prepared in the manner already described by us² was selected as the source of protein because our earlier experiments showed this product to be practically free from the vitamine which it was here proposed to investigate. On the basal ration selected, growing rats of 60 to 120 gm. in body weight begin to decline in weight within a few days. Their food intake decreases and they invariably die within 80 days unless a source of water-soluble vitamine is furnished.³ We fed the dried vegetable to be tested apart from the basal ration, so that the dosage might be accurately ascertained. With few exceptions the rats ate all the dried products each day; the data for this factor consequently have a strictly quantitative value in the comparisons between different tests.

Starting with healthy growing rats approximating 90 gm. in body weight the experiments were extended over 8 weeks with each dried food. The daily doses of the latter were varied, 1 and 0.5 gm. portions—in some cases 0.2 and 2 gm. doses—being tested.⁴ At the end of this period, especially when growth had not proceeded at the normal rate, many of the animals were tested for a further period of 6 weeks with our standard mixed food or with daily additions of 0.2 gm. of dried brewery yeast⁵ to determine whether the failures to grow satisfactorily had actually been due to lack of water-soluble vitamine rather than some other incidental factor.

The outcome of these comparative tests is shown in Charts I to X. In these experiments *alfalfa* and *clover* surpassed all the other nine products tested in equal doses as sole sources of water-soluble vitamine. Several of the animals (Rats 5769, 5768, 5775, 5790, Charts I and II) gained 175 gm. or more in weight during the 8 weeks period—a growth equal to the best which we have observed in our stock colony. This is a result far better than we

² Osborne, T. B., and Mendel, L. B., *J. Biol. Chem.*, 1917, xxxii, 309.

³ Osborne, T. B., Wakeman A. J., and Ferry, E. L., *J. Biol. Chem.*, 1919, xxxix, 35.

⁴ The portions used were measured by means of small, calibrated scoops which were designed to deliver them in fairly accurate amounts. However, in the course of the experiments it was discovered that when the atmospheric humidity was unusually high the dosage of the dry powders furnished in this way was sometimes only approximately correct.

⁵ Osborne, T. B., and Mendel, L. B., *J. Biol. Chem.*, 1917, xxxi, 149.

have ever secured with even 16 cc. of milk per day fed as a source of water-soluble vitamine in addition to the same basal ration. Half of this allowance, *i.e.* 0.5 gm. per day, of dry alfalfa or clover is not equally efficient (Rats 5744, 5750, 5723, 5772, 5770, 5774, Charts I and II).

Tomato is rich in water-soluble vitamine. 1 gm. daily doses promoted good growth when the animals would eat this quantity (Rats 5928, 6008, Chart III). At first it was frequently refused, perhaps because of the acid flavor of the thus concentrated, highly acid product. 0.5 gm. doses of dried tomato were by no means so effective (Rats 5878, 5892, 5871), yet even 0.2 gm. quantities occasionally promoted limited growth or at least maintenance.

Spinach, *cabbage*, *turnip*, and *carrot* were not widely unlike in their comparative potency as sources of water-soluble vitamine. 1 gm. doses did not surpass 0.5 gm. quantities of alfalfa and clover (and perhaps tomato) in the results attained; whereas with the smaller amounts growth was not maintained (Charts IV to VII). The *beet root* (Rats 5972, 5980, Chart VI) did not equal the other roots tested. This is in harmony with the outcome of the observations of Steenbock and Gross⁶ on the sugar beet and mangels, in contrast with the carrot, rutabaga, and dasheen. The *timothy* hay though potent in the earlier periods of the experiment (Rats 5931, 5867, 5865, Chart VIII) proved disappointing in the long run, in view of the expectations raised by the brief trials already reported.⁷

The *potato* is evidently as rich in water-soluble vitamine as some of the roots tested, although similar quantities of the leguminous hays, alfalfa and clover, or the tomato promoted more rapid growth. Compared in 1 gm. daily doses there was little if any advantage in potato retaining the outer layers (Rats 5954, 6021, 6017, Chart IX), over peeled potato of the same age (Rats 5961, 5955, 5978, Chart X). This corresponds with the observation that the dried *potato peel* (Rats 5963, 6037) is no richer in the vitamine than are corresponding quantities of whole potato (Rats 5926, 5975, 5977, 6042). Even 2 gm. daily doses of *peeled potato*

⁶ Steenbock, H., and Gross, E. G., *J. Biol. Chem.*, 1919, xl, 501.

⁷ Osborne, T. B., and Mendel, L. B., *J. Biol. Chem.*, 1919, xxxix, 29, Chart II.

(Rats 5981, 5984, 5985) did not promote growth at the normal rate during the entire 8 weeks period.

Hess and Unger⁸ reported a slight difference in the antiscorbutic properties of old and fresh carrots. The comparative tests which we have made with *old* and *new* potatoes respectively in both 1 gm. and 0.5 gm. daily additions have not given indications of any noteworthy differences in content of the water-soluble vitamine here under investigation (Rats 5954, 6021, 6017, 5926, old potato; Rats 6082, 6044, 6086, 5975, 5977, 6042, new potato).

Bachmann⁹ has reported that certain yeasts will not grow on synthetic media unless organic material is added in small amounts. The substances which when added to Nägeli's solution made it possible for the yeast to cause fermentation were said to be such as "have been found to be rich in vitamins, especially water-soluble B." Extracts were prepared from potato, carrot, celery, beet, onion, rutabaga, cabbage, cauliflower, parsnip, and lettuce. "All the extracts furnished the necessary substance for the yeast to grow and ferment the medium even though the amount added was very little . . . the extracts were not equally potent." It is suggested by Bachmann that the method might be used to determine the presence of certain vitamins and even to determine quantitatively the amount present in various substances.

The statistical facts—total gains in weight and total food intakes in the 8 weeks period during which the dried plant products were fed by us in comparable doses each day to rats—are summarized in Table I.

As might be expected the greatest gains were in general the outcome of food intakes large in comparison with those of the rats which made smaller increments of weight. This is conspicuous in comparing the food intake and gains after feeding different amounts of the sources of vitamine. It should be noted that the figures recorded in the table as "gain" represent the end result of 8 weeks tests in the course of which a number of the rats, as shown in the charts of growth, reached larger size and subsequently declined somewhat owing, presumably, to the inadequate supply of vitamine. If the food intakes in cases of the smaller gains seem

⁸ Hess, A. F., and Unger, L. J., *Proc. Soc. Exp. Biol. and Med.*, 1919, xvi, 52.

⁹ Bachmann, F. M., *J. Biol. Chem.*, 1919, xxxix, 235.

456 Nutritive Factors in Plant Tissues. III

TABLE I.

*Total Gains in Body Weight and Food Intake.**
8 Weeks Period.

Food.	1 gm. daily.			0.5 gm. daily.		
	Rat No.	Gain in weight.	Total food intake.	Rat No.	Gain in weight.	Total food intake.
		<i>gm.</i>	<i>gm.</i>		<i>gm.</i>	<i>gm.</i>
Alfalfa.	5769	200	655	5744	144	536
	5768	179	594	5750	121	499
	5868	146	562	5723	106	516
Clover.	5775	197	663	5774	112	489
	5790	177	565	5770	102	441
	5791	150	497	5772	99	448†
Tomato.	6008	122	543	5878	88	453
	5936	120	516	5892	70	484
	5932	118	468			
	5928	115	544			
Spinach.	5870	119	476†	5808	87	439
	6014	101	445	5817	61	364
	5767	81	395	5857	32	326
	5914	75	456			
Cabbage.	5907	99	472	5922	52	314
	5921	91	364	5918	49	314
	6009	58	472	5919	30	271
Turnip.	5920	96	406	5842	46	306
	5869	68	268	5895	30	312
	5820	66	347†	5839	20	258
Carrot.	5824	78	398	5819	49	334
	5816	78	439†	5805	38	306
	6016	66	393	5802	36	287
	5758	46	398			
Timothy.	5867	42	367	5912	22	261
	5931	40	342	5970	5	317†
	5865	10	314	5909	-2	214

TABLE I—*Concluded.*

Food.	1 gm. daily.			0.5 gm. daily.		
	Rat No.	Gain in weight.	Total food intake.	Rat No.	Gain in weight.	Total food intake.
		<i>gm.</i>	<i>gm.</i>		<i>gm.</i>	<i>gm.</i>
Peeled potato.	5961	63	355			
	5978	52	367			
	5955	45	358			
Whole " old.	6021	60	439	5926	11	269
	5954	57	351			
	6017	40	368			
" " new.	6086	83	366	5977	25	296
	6082	54	361	5975	5	306
	6044	43	362	6042	4	288
Potato peel.				6037	4	225
				5963	4	267
Beet root.	5980	6	240			
	5972	-9	246			
0.2 gm. daily.						
Tomato.	5862	51	321			
	6018	32	347			
	6023	30	305			
	5866	2	255			

* The food intake is exclusive of the dried vegetable supplied.

† Some of the food was spilled by the rat so that the data are not entirely accurate.

disproportionately large it must be recalled that even when no growth whatever occurs a maintenance requirement must be met. In comparing the quota of the food devoted to growth, the maintenance requirement ought strictly to be subtracted from the total intake, and comparisons made on the basis of the difference. Inasmuch as the maintenance needs vary at different ages this calculation cannot be satisfactorily carried out with the data available. In earlier experiments with foods of similar make-up

we¹⁰ found male rats, beginning at 90 gm. in weight, to make average gains of approximately 85 gm. in 8 weeks on a food intake of about 450 gm. Many of the animals in the present series have given even better results.

Inasmuch as the daily allowance of water-soluble vitamine was fixed, whereas the food intake varied with the individual and still more with the character of the plant product fed, the ratio of the latter to the total food eaten varied. In the case of rats receiving 1 gm. portions the vitamine-bearing vegetable product ranged from 10 per cent of the food intake or less in those which grew best, to 15 per cent or more at the other extreme of the series. In the 0.5 gm. experiments the content of plant food in relation to the total food ranged from about 5 to 9 per cent. Thus, the growth during the period when the dried tomato fed was equivalent to about 5 per cent of the food was greater than that in animals for which carrots supplied nearly three times this proportion. Dried brewery yeast is effective in far smaller proportions.⁵ The method is not accurate enough and the statistics not sufficiently abundant to permit more than the approximate comparisons already referred to.

EXPLANATION OF CHARTS.

The following charts represent the growth of rats beginning with a body weight of approximately 90 gm. during a period of 8 weeks in which the sole source of water-soluble vitamine was supplied by the indicated quantities of various dried vegetable tissues, fed daily apart from an otherwise adequate standard food mixture. At the end of the 8 weeks feeding trial the growth capacity of the animals was further tested by feeding 0.2 gm. of dried brewery yeast in place of the dried vegetable, or, in a few cases, substituting the ordinary mixed food of our stock colony for the previous diet. The duration of the yeast feeding is indicated by the interrupted line (-----) and the mixed food by the designation (—:—·—·—). Days on which animals failed to eat all the dried vegetables offered are indicated by asterisks on the curve. The statistics for food intake, etc. are summarized in Table I.

¹⁰ Osborne, T. B., and Mendel, L. B., *J. Biol. Chem.*, 1915, xx, 351.

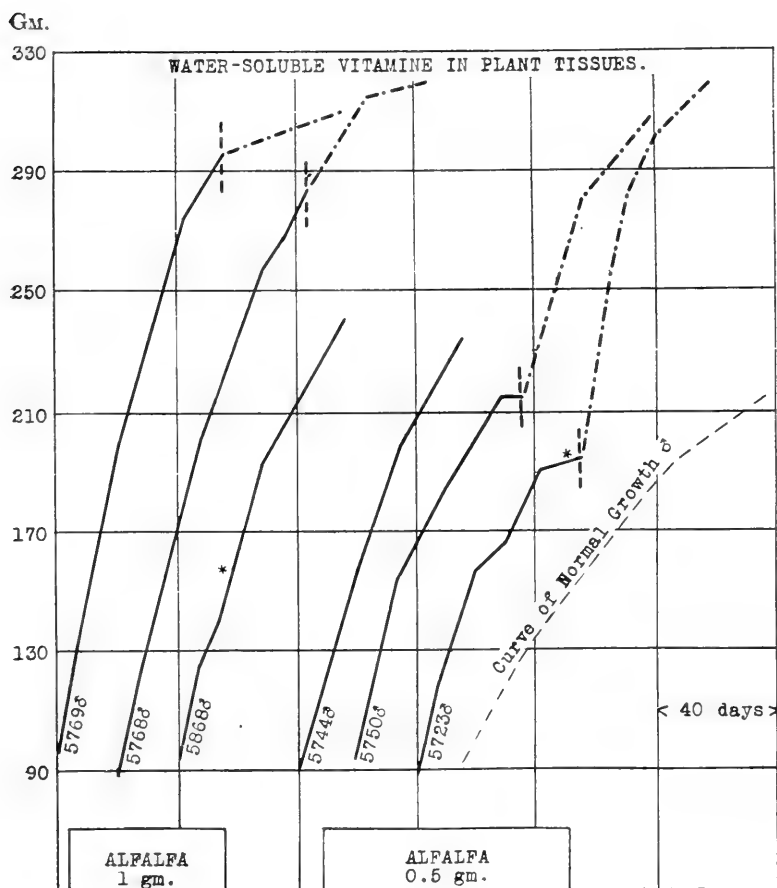

CHART I.

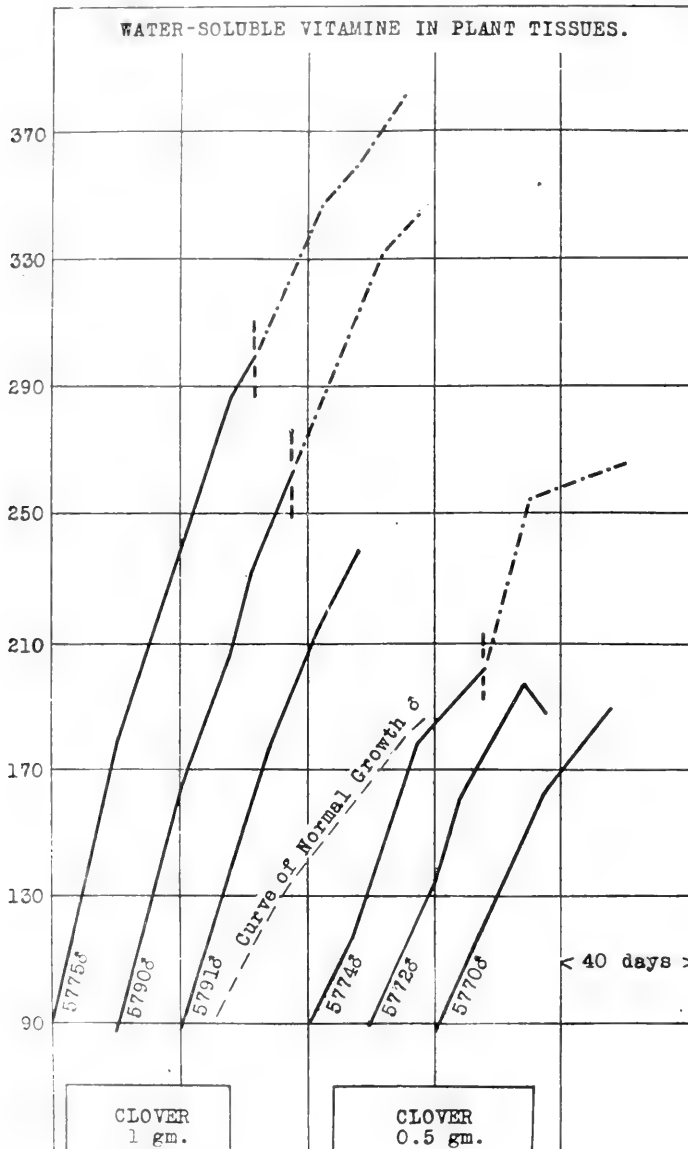

CHART II.

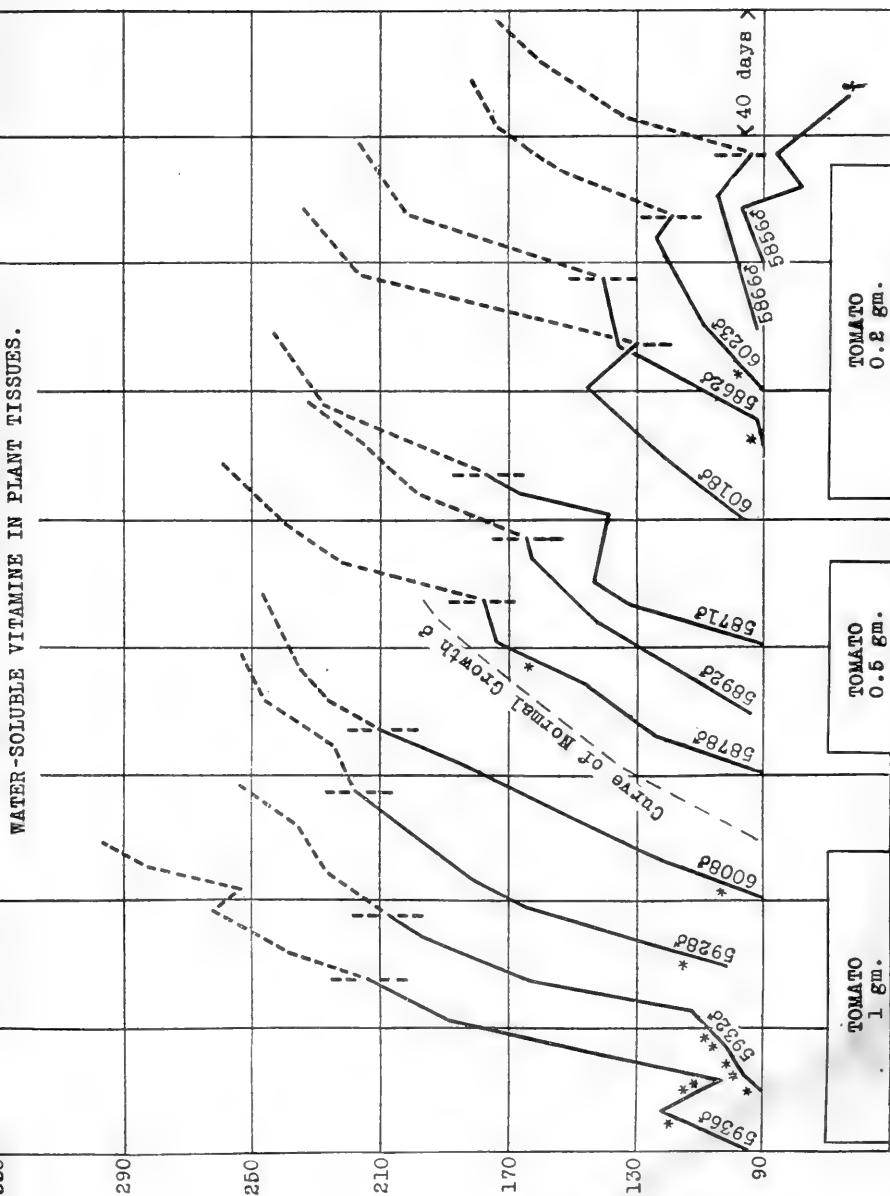

CHART III.

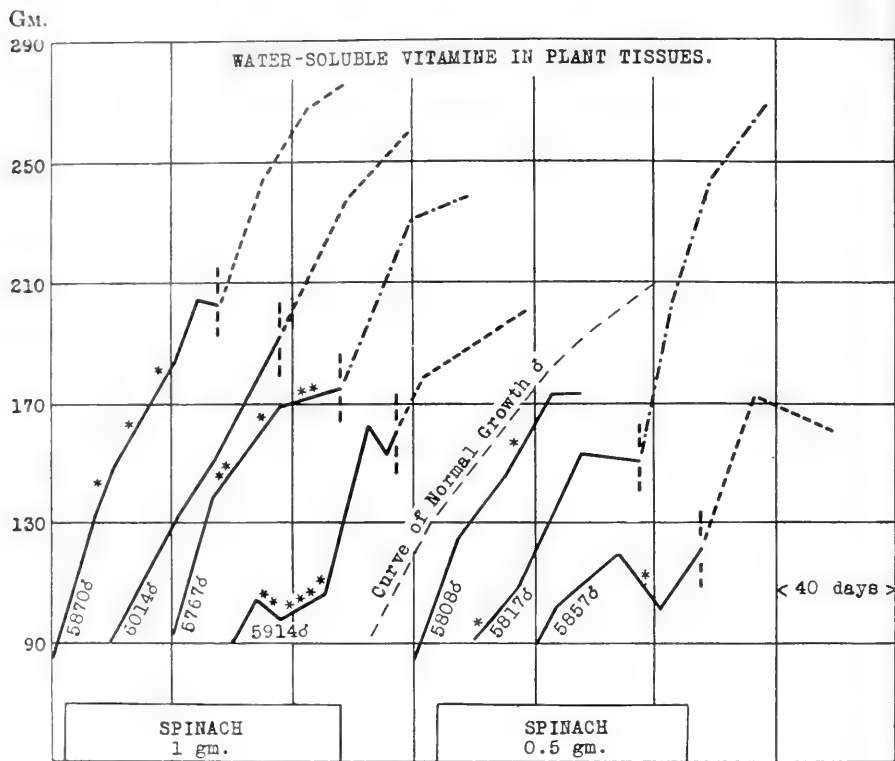

CHART IV.

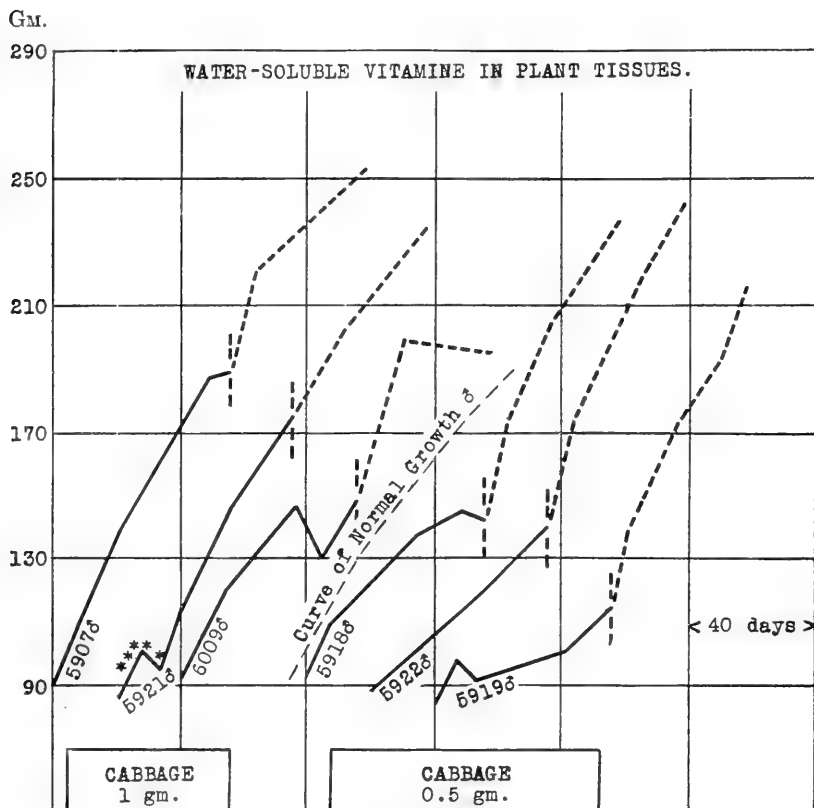

CHART V.

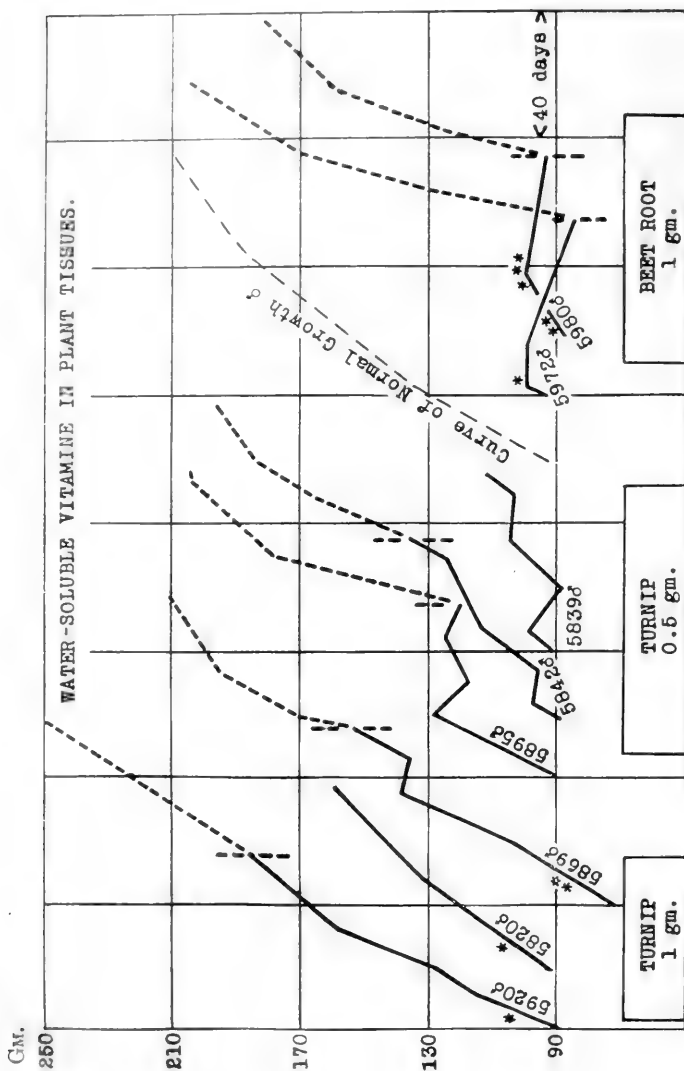

CHART VI.

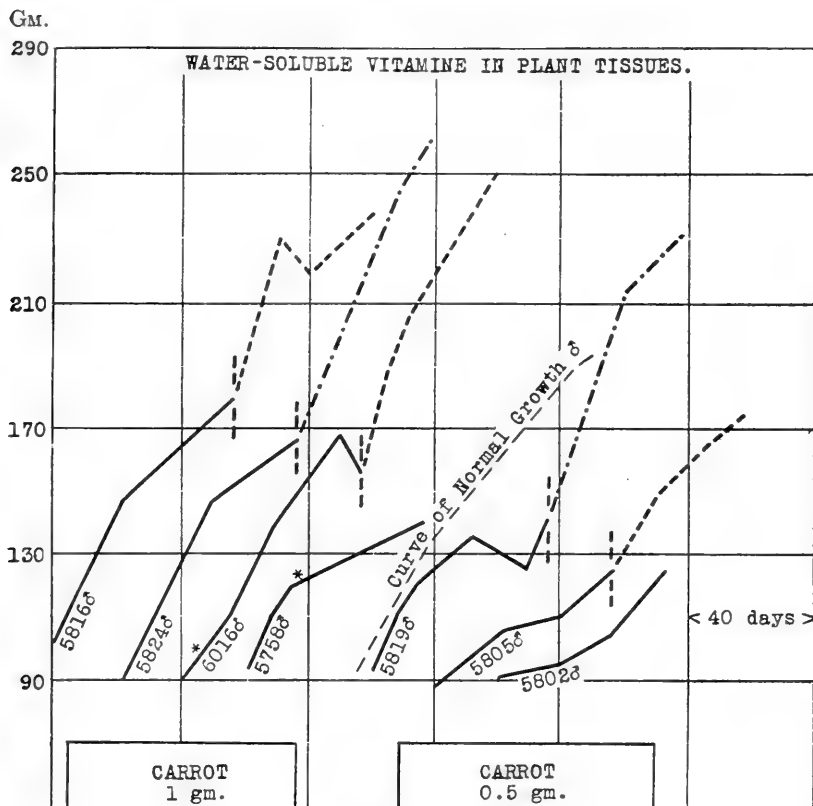

CHART VII.

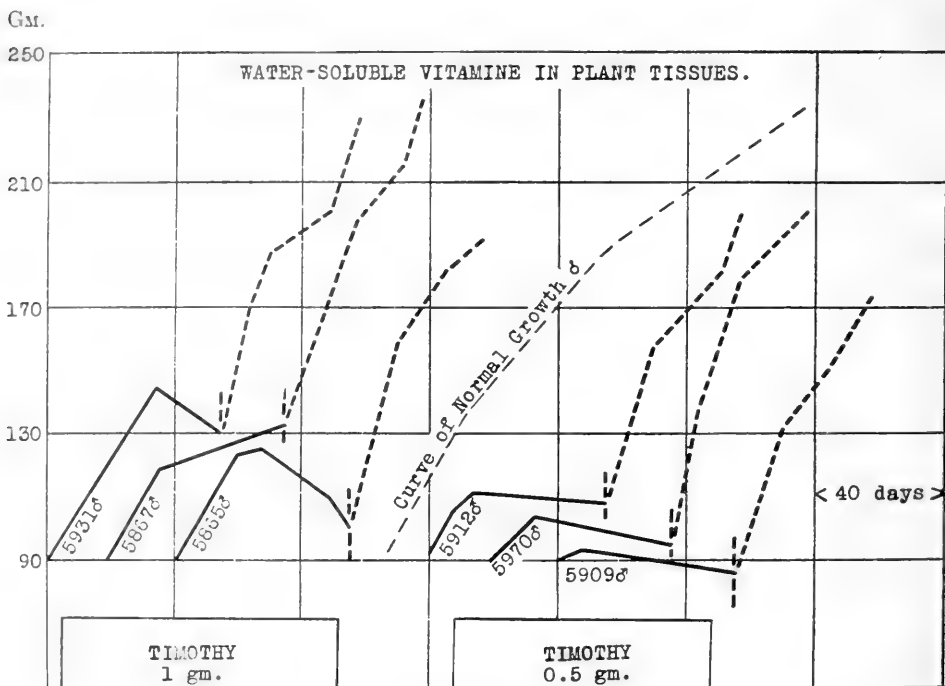

CHART VIII.

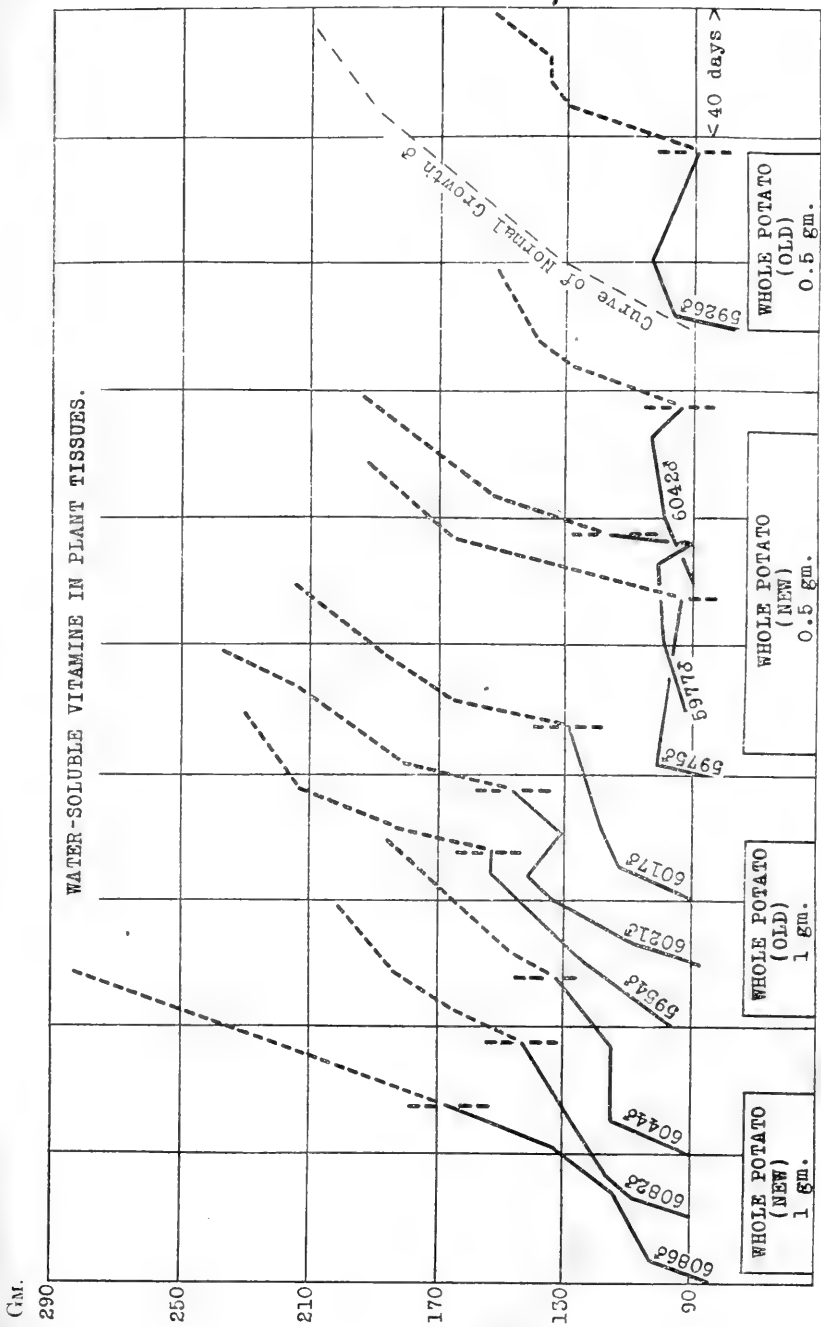

CHART IX.

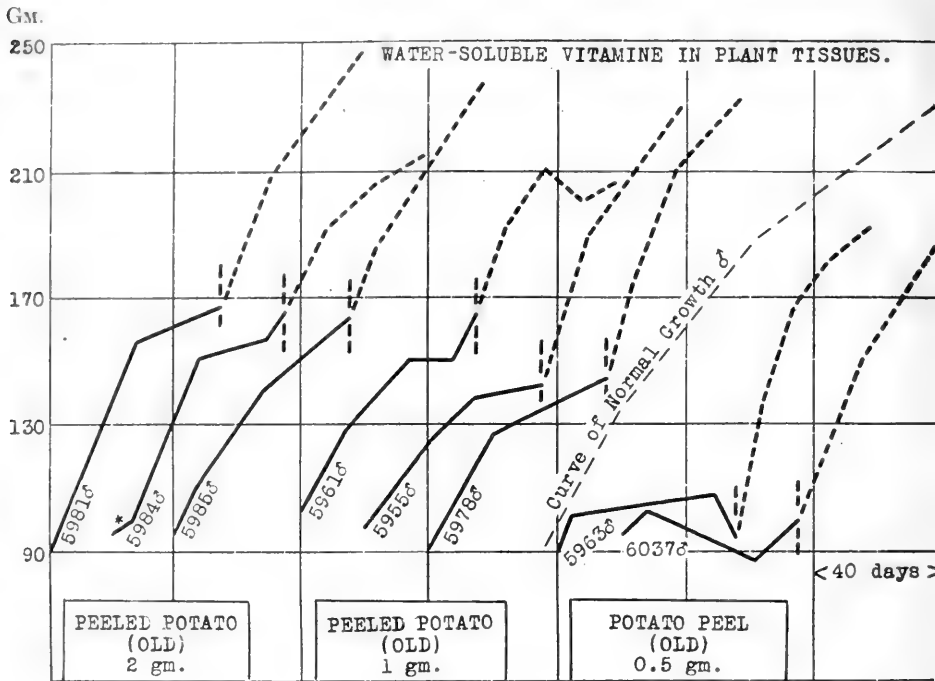

CHART X.

467

THE DIGESTIBILITY OF CHICKEN SKIN.

BY EDWARD F. KOHMAN AND H. A. SHONLE.

(From the Food Research Laboratory, Bureau of Chemistry, Department of Agriculture, Indianapolis.)

(Received for publication, February 3, 1920.)

While certain feeding experiments were being conducted in poultry fattening by the use of various feed by-products, an opportunity presented itself to collect a considerable quantity of chicken skin. Advantage was taken of this to carry out two metabolism experiments to determine the digestibility of this food product. From 10 to 15 per cent of the edible nitrogen in the chicken is found in the form of skin. The fat content of this skin may vary from a very small percentage to as high as 50 per cent or even more, counting the loose layers of fat lying next to the muscular tissue as part of the skin, as was done in the experiments alluded to above.

In order to remove part of this fat to make the skin more suitable to the metabolism experiments, the ground skin was heated in a water bath and then the larger part of the fat was expressed through a cloth bag. In this manner considerable water extract was also expressed, which gelatinized under the layer of fat upon cooling. This extract was combined with the skin from which it had been expressed and the whole thoroughly mixed again. The skin as then used for the experiments had 26.3 per cent fat and 3.03 per cent nitrogen. To prepare it for eating it was rolled in balls and fried. In this form it was a fairly palatable dish. It can be calculated from Tables I and II that during the experimental period this skin furnished 67.5 per cent of the nitrogen in the diet for Subject A and 65.1 per cent for Subject B.

It should be said of the chicken skin used in the experiments that it came from broilers and roasters as they came from the

range to the feeding station and from similar birds after a 2 weeks period of fattening on a buttermilk mash. The fattened birds were in the majority, and, as they were all commercially dry picked, the skin had an abundance of pin feathers.

The details of the experiments are given in Tables I to V. Each period consisted of 5 days, the experimental period being preceded and followed by a like period with the exception that milk, eggs, and meat took the place of the chicken skin. Other-

TABLE I.
Food Intake, Subject A, Man, Weight 120 Lbs.

Food.	Fore period.		Experimental period.		After period.	
	Food.	Nitrogen.	Food.	Nitrogen.	Food.	Nitrogen.
	<i>gm.</i>	<i>gm.</i>	<i>gm.</i>	<i>gm.</i>	<i>gm.</i>	<i>gm.</i>
Apples.....	1,050	0.26	1,050	0.26	1,050	0.26
Prunes.....	450	0.50	450	0.50	450	0.50
Oranges.....	1,189	1.53	1,189	1.53	1,213	1.57
Lettuce.....	240	0.46	200	0.38	200	0.38
Tomatoes.....	500	0.96	500	0.96	500	0.96
Sugar.....	514		324		108	
Tapioca.....	73	0.02	73	0.02	73	0.01
Bread.....	616	8.38	550	7.92	550	7.34
Potatoes.....	1,877	6.61	1,877	6.61	1,877	6.61
Butter.....	412	0.66	135	0.22	194	0.31
Eggs.....	496	10.61				
Meat.....	575	16.71			1,156	38.18
Milk.....	2,486	11.61				
Skin.....			1,260	38.18		
Total N.....		58.31		56.58		56.12
Total calories.....	14,697		11,589		8,792	

wise the diet was kept uniform throughout and an attempt was made to have it approximately normal for the individuals concerned. No attempt was made to limit the intake. As a result the caloric intake for the fore period was considerably higher than the after period due in part to the novelty of the experiment and the cold weather in the beginning, in part to the high fat content of the first lot of Hamburger steak purchased, and a combination of other circumstances. The feces for the different periods

TABLE II.

Food Intake, Subject B, Man, Weight 140 Lbs.

Food.	Fore period.		Experimental period.		After period.	
	Food.	Nitrogen.	Food.	Nitrogen.	Food.	Nitrogen.
	<i>gm.</i>	<i>gm.</i>	<i>gm.</i>	<i>gm.</i>	<i>gm.</i>	<i>gm.</i>
Apples.....	1,078	0.27	1,078	0.27	1,078	0.27
Prunes.....	562	0.62	562	0.62	450	0.50
Oranges.....	1,240	1.60	1,209	1.56	1,150	1.48
Lettuce.....	240	0.46	200	0.38	200	0.38
Tomatoes.....	500	0.96	500	0.96	500	0.96
Sugar.....	459		270		278	
Tapioca.....	85	0.02	85	0.02	85	0.01
Bread.....	776	10.55	686	9.88	722	9.60
Potatoes.....	2,403	8.48	2,403	8.48	2,403	8.48
Butter.....	482	0.77	371	0.59	242	0.39
Eggs.....	484	10.36				
Meat.....	670	19.45			1,285	42.42
Milk.....	3,820	17.23				
Skin.....			1,400	42.42		
Total N.....		70.77		65.18		64.49
Total calories.....	17,237		14,753		11,070	

TABLE III.

Utilization of Nitrogen.

	Subject A.			Subject B.		
	Fore period.	Experimental period.	After period.	Fore period.	Experimental period.	After period.
Urine, <i>cc.</i>	6,985	8,125	9,210	7,395	6,970	8,185
Feces, <i>gm.</i>	524	464	573	1,145	921	661
Urinary nitrogen, <i>gm.</i>	38.33	47.69	54.04	55.30	59.90	61.99
Fecal " ".....	7.57	8.14	8.45	13.01	11.08	8.73
Nitrogen balance, ".....	+12.41	+0.75	-6.37	+2.46	-5.80	-6.11
Utilization, <i>per cent.</i>	87.02	85.61	84.94	83.69	83.00	86.49

TABLE IV.
Fat Ingested.

Food.	Subject A.			Subject B.		
	Fore period.	Experimental period.	After period.	Fore period.	Experimental period.	After period.
	<i>gm.</i>	<i>gm.</i>	<i>gm.</i>	<i>gm.</i>	<i>gm.</i>	<i>gm.</i>
Butter.....	350	115	165	410	316	206
Eggs.....	52			51		
Meat.....	109		74	128		82
Skin.....		332			369	
Milk.....	99			153		
Bread.....	8	7	7	10	9	9
Total.....	618	454	246	752	694	297

TABLE V.
Utilization of Fat.

	Subject A.			Subject B.		
	Fore period.	Experimental period.	After period.	Fore period.	Experimental period.	After period.
Dry matter in feces, <i>per cent</i>	25.91	25.64	23.28	17.85	14.96	20.86
Fat in dry matter, " "	12.80	12.17	9.84	13.44	15.06	7.84
" excreted, <i>gm</i>	17.37	14.48	13.13	27.46	20.75	10.83
" utilized, <i>per cent</i>	97.2	96.8	94.7	96.3	97.0	96.4

were marked off by means of lamp black. The vegetables and fruits were not analyzed, the composition given by Atwater and Bryant being used.¹

CONCLUSION.

In experiments in which 65.1 to 67.5 per cent of the nitrogen of the diet was supplied by chicken skin there was as good utilization of the nitrogen as when the same proportion of the nitrogen was supplied by meat, eggs, and milk.

¹Atwater, W. O., and Bryant, A. P., *U. S. Dept. Agric., Off. Exp. Stations, Bull. 28*, revised, 1906.

EFFECT OF SLEEP UPON THE ALKALI RESERVE OF THE PLASMA.

By J. B. COLLIP.

(From the Departments of Biochemistry and Physiology, University of Alberta,
Edmonton, Canada.)

(Received for publication, February 17, 1920.)

It has been shown by Leathes (1) that the CO_2 tension of alveolar air is definitely increased as a result of sleep. He is of the opinion that the respiratory center is depressed during sleep and that the morning alkaline tide in the urine, described by him, is due to increased respiratory activity on waking. That the respiratory center is depressed during sleep would seem quite possible. It is also to be expected, however, that with depression of the respiratory center there would occur a slight increase in the C_H of the blood. As the reaction of the blood is determined

by the molecular ratio $\frac{\text{H}_2\text{CO}_3}{\text{NaHCO}_3}$ (2) it would follow, if the CO_2

tension of the alveolar air is increased without a proportionate rise in the blood bicarbonate, that the C_H of the blood would be slightly increased. In order to determine whether the plasma bicarbonate is altered during sleep, blood samples were taken for analysis by the Van Slyke method from nine students who kindly volunteered their services. The samples were taken in the evening shortly before the subjects retired and then again in the early morning, the subjects first being roused from a sound slumber. The blood was aspirated from an arm vein into a glass syringe containing a trace of potassium oxalate. It was transferred at once to a paraffined glass tube and centrifuged. The plasma was then saturated in a separating funnel with CO_2 at the tension of the alveolar air of the normal subject and the determination of the CO_2 content made by the method of Van Slyke and Cullen (3). The CO_2 bound as bicarbonate by 100 cc. of plasma was calculated and the results are shown in Table I.

TABLE I.

	CO ₂ bound as bicarbonate by 100 cc. of plasma.	
	Evening. 9.30 to 11 p.m.	Morning. 6 to 7.30 a.m.
	cc.	cc.
W. W. B.....	61	62
W. F. C.....	68	64
E. M. C.....	65	61
G. V. F.....	65	62
R. E. F.....	61	58
D. D. H.....	65	65
E. G. K.....	68	63
E. D. T.....	66	63
G. F. Y.....	67	67

DISCUSSION.

It was found in three cases that the bicarbonate level of the venous plasma was unaltered as a result of sleep, while in the remaining six instances there was a definite increase in this factor.

These results taken in conjunction with the observations of Leathes (1) that there is a definite rise in the alveolar CO₂ during sleep would indicate that the C_H of the blood is actually increased at this time. This increase in blood C_H may be effected in one of two ways, an increase in alveolar CO₂ without a relative increase in blood bicarbonate, or an increase in alveolar CO₂ with an actual fall in blood bicarbonate. One or the other of these types of regulation of blood C_H is manifested by the sleeping individual.

SUMMARY.

The alkali reserve of the blood plasma is either unaltered or depressed during sleep. An actual increase in the C_H of the blood during sleep is indicated.

I wish in conclusion to thank the students who offered their services, and Dr. P. L. Baekus who assisted in making the analyses.

BIBLIOGRAPHY.

1. Leathes, J. B., *Brit. Med. J.*, 1919, ii, 165.
2. Henderson, L. J., *Ergebn. Physiol.*, 1909, viii, 254.
3. Van Slyke, D. D., and Cullen, G. E., *J. Biol. Chem.*, 1917, xxx, 289.

THE UTILIZATION OF α -METHYLGLUCOSIDE BY *ASPERGILLUS NIGER*.

BY ARTHUR W. DOX AND G. W. ROARK, JR.

(From the Chemistry Section, Iowa State College, Ames.)

(Received for publication, January 27, 1920.)

The striking difference in the rate of utilization of α - and β -methylglucoside by *Aspergillus niger* was pointed out some years since by Dox and Neidig.¹

When a culture medium containing α -methylglucoside as the only source of carbon was inoculated with spores of *Aspergillus niger*, only a very meager growth of the fungus resulted. Even after several weeks the surface of the medium was only incompletely covered with mycelium in isolated colonies. On the other hand, the isomeric β -methylglucoside gave a dense mycelium which covered the entire surface. Examination of the substrate in both cases showed that in 6 days 100 per cent of the β -glucoside had disappeared, but only 1.2 per cent of the α -glucoside. Even after 20 days the latter had diminished by only 8.2 per cent. Experiments with enzyme preparations showed a similar difference in behavior toward the two isomers. Under practically the same conditions, 5.2 per cent of the α - and 85.5 per cent of the β -glucoside were hydrolyzed.

From these experiments it is apparent that α -methylglucoside can be utilized to a slight extent by this organism and that the enzyme necessary for its hydrolysis is produced in small amount under ordinary conditions. Attempts to bring about an adaptation of the fungus by transferring the mycelium to the glucoside solution after previous growth on sucrose did not result in any marked increase in availability of the substrate. The conditions under which this experiment was conducted were not such as to induce the maximum utilization of the substrate.

¹ Dox, A. W., and Neidig, R. E., *Biochem. Z.*, 1912, xlvi, 397.

This method of bringing about an apparent adaptation of an organism to a new substrate, by allowing the organism to attain a vigorous growth then replacing the original medium by the new substrate, was first employed by Pottevin.² In this way, Pottevin claims to have succeeded in inducing *Aspergillus niger* to secrete in demonstrable quantities the enzymes necessary for the hydrolysis of the two isomeric methylgalactosides. In his experiments, however, the substrate contained all the elements of the original culture medium. His experiments with methylgalactoside and our previous experiments with α -methylglucoside were therefore not strictly comparable. Subsequent experiments on autolysis of this organism, conducted by one of us,³ showed that replacement of the exhausted medium by a quantity of fresh medium resulted in a much denser growth and less autolysis than replacement of the medium by a solution of pure sucrose. It seems probable that the utilization of the new substrate depends to a considerable extent upon the presence of an available source of nitrogen, and perhaps also mineral salts.

EXPERIMENTAL.

The object of this work was to determine more precisely the extent to which *Aspergillus niger* can utilize α -methylglucoside under optimum conditions. As already stated, this substance when introduced into a culture medium as the only source of carbon, enables spores of *Aspergillus niger* to germinate and develop to a thin scanty mycelium which seems to direct most of its vitality toward the formation of spores. α -Methylglucoside is, however, not toxic since its presence in a medium containing sufficient sugar has no inhibitory effect upon growth. The following experiments demonstrate this fact quite clearly.

A culture medium was prepared according to Czapek,⁴ omitting the sucrose. 50 cc. of this were placed in each of three 200 cc. Jena flasks. To the first was added 2 per cent of sucrose, to the second 2 per cent of α -methylglucoside, and to the third 1 per cent of each of the preceding. The flasks were sterilized, inocu-

² Pottevin, H., *Ann. Inst. Pasteur*, 1903, xvii, 31.

³ Dox, A. W., *J. Biol. Chem.*, 1913-14, xvi, 479.

⁴ Czapek, F., *Beitr. chem. Physiol. u. Path.*, 1903, iii, 47.

lated with spores of *Aspergillus niger*, and placed in an electric incubator at 35° until the resulting mycelium had become covered with spores. The mycelium was then filtered on Gooch crucibles, washed, dried, and weighed.

The filtrates gave no test for reducing sugar. It is apparent from Table I that in both Nos. 2 and 3 some of the glucoside has been utilized by the fungus. Medium 3, which contained only half as much sucrose as No. 1 and half as much glucoside as No. 2, yielded more mycelium than half the sum of those from Nos. 1 and 2.

TABLE I.

Medium No.	Weight of dry fungus.
	<i>gm.</i>
1	0.2779
2	0.0729
3	0.1830

The above experiment was repeated, using Raulin's medium upon which this organism thrives still better. No. 1 contained no glucoside, No. 2 contained 2 per cent of glucoside in place of the sucrose, and No. 3 contained 1 per cent of glucoside in addition to the full amount of sucrose.

TABLE II.

Medium No.	Weight of dry fungus.		
	1	2	Average.
	<i>gm.</i>	<i>gm.</i>	<i>gm.</i>
1	0.5906	0.5720	0.5813
2	0.0715	0.0851	0.0783
3	0.6970	0.7203	0.7087

The amount of glucoside utilized is evidently greater in No. 3 than in No. 2 (Table II). The probable explanation for this is the fact that after the fungus has attained a vigorous growth on the sucrose there is a much greater amount of mycelium to attack the glucoside than in the case of the scanty growth without the sucrose. Further experiments, recorded in Table III, apparently failed to confirm this observation, because the utilization of gluco-

side was carried practically to completion in all cases. The increase due to 1 per cent of glucoside is just about half the yield from 2 per cent of glucoside alone.

The effect of cultivating the fungus on Raulin's medium until vigorous growth and then replacing the medium by a similar medium in which α -methylglucoside is substituted, is quite striking. In the experiments recorded in Table IV the fungus

TABLE III.

Medium No.	Weight of dry fungus.					
	1	2	3	4	5	Average.
	<i>gm.</i>	<i>gm.</i>	<i>gm.</i>	<i>gm.</i>	<i>gm.</i>	<i>gm.</i>
1	0.9115	0.8924	0.8112	0.8574	0.8552	0.8655
2	0.1606	0.1423	0.1474	0.1421	0.1417	0.1468
3	1.0206	0.9755	0.9014	0.9045	0.8955	0.9393

TABLE IV.

Age of culture after transfer.	Before spore formation.		After spore formation.	
	Rotation of medium.	Decrease.	Rotation of medium.	Decrease.
<i>days</i>	$^{\circ}$ V.*	<i>per cent</i>	$^{\circ}$ V.	<i>per cent</i>
0	17.5	0.0	18.2	0.0
1	14.2	18.8	13.6	25.1
2	13.6	22.2	12.2	32.9
3	12.2	30.2	11.4	37.5
4	11.8	32.5	10.8	40.6
5	11.6	33.7	10.0	45.0
6	11.2	36.0	8.8	51.6
7	11.0	37.1	6.8	61.5
8	11.0	37.1	7.0	62.6

* $^{\circ}$ V. = degrees on Ventzke scale. For conversion to angular degrees multiply by 0.3468.

was first grown on Raulin's medium. In the first series the transfer was made just before and in the second series just after the formation of spores. The transfer of media was made by first syphoning off the medium and replacing twice with equal amounts of sterile distilled water, each time allowing the mycelium and water to remain in contact about 45 minutes, taking care not to wet the surface of the culture, and finally replacing the water

with medium containing glucoside as the sole source of carbon. On successive days the medium was removed from one of these flasks and an aliquot examined polarimetrically after clarification with neutral lead acetate. From the decrease in optical rotation the per cent loss of glucoside is calculated. The glucose was used up by the fungus as fast as it was liberated from the glucoside, as is shown by the fact that the test with Fehling's solution was invariably negative. Qualitative tests for methyl alcohol were, however, positive.

As may be seen from Table IV, the more mature cultures utilize a larger percentage of glucoside in a given time. This

TABLE V.

Age of culture after transfer.	Before spore formation.		After spore formation.	
	Rotation of medium.	Decrease.	Rotation of medium.	Decrease.
<i>days</i>	$^{\circ}V.$	<i>per cent</i>	$^{\circ}V.$	<i>per cent</i>
0	17.9	00.0	17.7	00.0
1	13.4	25.1	14.0	20.9
2	11.2	37.4	12.4	29.9
3	9.0	49.7	11.6	34.4
4	9.0	49.7	10.6	40.1
5	7.0	60.9	7.8	56.4
6	5.8	67.6	5.2	70.6
7	4.4	75.4	4.8	72.1
8	2.8	84.3	3.8	78.4
9	2.0	88.9	1.6	90.9
10	1.8	89.9	1.4	92.1

is in accord with our previous results, since the older cultures in this case contained more actual vegetative mycelium. The difference in utilization is, however, greater than can be assigned to this cause alone.

A similar experiment was conducted to see if the presence of α -methylglucoside in the original medium would lead to a greater response. It was carried out under as nearly the same conditions as possible.

Table V shows that there is not so great a difference in the ability to utilize the glucoside before and after spore formation when the culture is first grown on a medium containing glucoside. This seems to indicate an adaptation of *Aspergillus niger* to

α -methylglucoside. Control flasks containing the sterile medium were carried along with these experiments. In every case there was a slight increase in rotation likely due to evaporation. This showed that there was no hydrolysis or molecular rearrangement of the glucoside due to standing at that temperature for a number of days.

Another attempt at adaptation of *Aspergillus niger* to α -methylglucoside was conducted in the following manner. A culture medium containing both sucrose and α -methylglucoside was prepared and distributed in a number of test-tubes, all of which were then sterilized. Inoculations were made successively from one tube to another as soon as the culture reached maturity. After cultivating the mold for nine generations on this medium the tenth transfer was made to 50 cc. of a medium containing

TABLE VI.

Age of culture.	Control.		Attempted adaptation.	
	Rotation of medium.	Decrease.	Rotation of medium.	Decrease.
<i>days</i>	$^{\circ}V$.	<i>per cent</i>	$^{\circ}V$.	<i>per cent</i>
0	17.8	0.0	17.8	0.0
6	17.0	4.4	16.8	5.6
6	17.0	4.4	17.0	4.4

glucoside but no sucrose. As a control, a parallel culture which had been propagated for the same number of generations on sucrose alone was transferred to another 50 cc. of the glucoside medium. The results are given in Table VI.

The extent of adaptation, if any, is so slight after nine successive generations of *Aspergillus niger* grown in the presence of glucoside as to be within the range of normal cultural variations.

SUMMARY.

Aspergillus niger grows very poorly on media containing α -methylglucoside as the only source of carbon, but readily on sucrose media in the presence of the glucoside. A vigorous culture transferred entire to the glucoside medium without sucrose may use up the glucoside more rapidly than a culture obtained by

direct inoculation of this medium with spores. If the original medium contained both sucrose and glucoside the latter disappears more rapidly from the second medium containing glucoside but no sucrose than when the original medium contained sucrose alone. Also there was a slight difference between the activity of cultures before and after spore formation.

A gradual cumulative adaptation through a number of generations cultivated on this substrate could not be demonstrated with any degree of certainty.

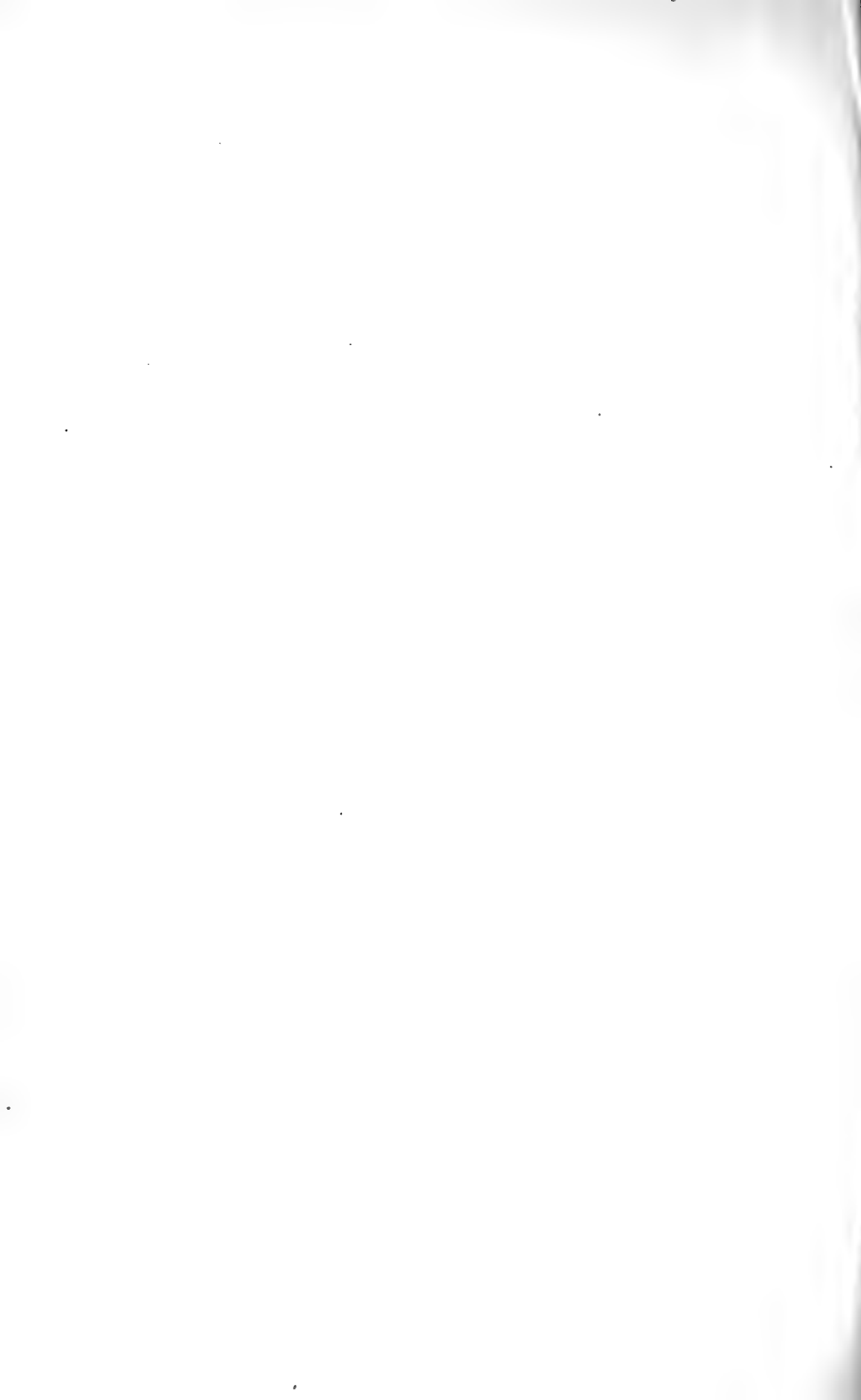

PROPERTIES OF THE NUCLEOTIDES OBTAINED FROM YEAST NUCLEIC ACID.

BY P. A. LEVENE.

(From the Laboratories of The Rockefeller Institute for Medical Research.)

PLATES 4 AND 5.

(Received for publication, March 1, 1920.)

The four nucleotides composing the molecule of yeast nucleic acid have now been isolated in crystalline form. Of these adenosinphosphoric acid was isolated by different methods by Jones and Kennedy¹ and by Levene.² The two substances seemed to differ from one another on the point of the crystal water.

Cytidinphosphoric acid also was obtained in two laboratories (Thannhauser and Dorfmueller³ and Levene⁴) and the two substances seemed to differ in their optical activity. Also the two samples isolated by the present writer showed minor differences in their rotatory power. The properties of guanosinphosphoric⁵ and uridinphosphoric acids⁶ had been given as found on substances as they were first obtained without further recrystallization.

The present work was undertaken for the sake of clearing up the above mentioned discrepancies and, further, for the sake of establishing the composition of the nucleotide as regards the crystal water, and for the sake of establishing the physical constants with greater rigor. In order to make the work possible, larger quantities of the crude material were required and were prepared. The results of the analysis of the carefully purified substance are as follows:

¹ Jones, W., and Kennedy, R. P., *J. Pharm. and Exp. Therap.*, 1919, xiii, 45.

² Levene, P. A., *J. Biol. Chem.*, 1919, xl, 415.

³ Thannhauser, S. J., and Dorfmueller, G., *Z. physiol. Chem.*, 1919, 104, 5.

⁴ Levene, P. A., *J. Biol. Chem.*, 1920, xli, 19.

⁵ Levene, P. A., *J. Biol. Chem.*, 1919, xl, 171.

⁶ Levene, P. A., *J. Biol. Chem.*, 1920, xli, 1.

Adenosinphosphoric acid (Fig. 1), according to Jones and Kennedy,¹ crystallizes with 1 molecule of crystal water. Levene, in his original work, found the air-dry substance anhydrous. The observation could not be repeated. Many samples have been analyzed since the first publication and all contained 1 molecule of crystal water. This was easily removed by drying under diminished pressure at the temperature of xylene vapor for 24 hours. The original sample was reanalyzed and again found practically anhydrous (1 per cent of water). In a sealed capillary tube the air-dry substance decomposed with effervescence at 195°C. (corrected).

Guanosinphosphoric acid (Fig. 2) crystallized in long needles of the appearance of the crystals of guanosin. It crystallized with 2 molecules of crystal water, which could be removed completely on drying under diminished pressure at the temperature of xylene vapor. In a sealed capillary tube the air-dry substance softened and became semitransparent at 175°C. and melted at 180°C. (corrected).

Uridinphosphoric acid (Fig. 3) was recrystallized out of methyl alcohol. The crystals formed slowly on evaporation of the alcohol. The larger crystals were often superimposed by deposits of smaller crystals, hence the photographic reproduction of the crystals was difficult. Besides, the yield of the material was rather small. For this reason it was decided to measure the optical rotation also of the monoammonium salt, which has good physical properties and a convenient solubility. The free acid crystallized in elongated prisms with pointed ends and melted in a sealed capillary tube at 198.5°C.

The monoammonium salt crystallized in prismatic needles which contained no crystal water. The air-dry substance heated in a sealed tube contracted and turned semitransparent at 200°C. (corrected), and decomposed at 242°C.

Cytidinphosphoric acid (Fig. 4) on repeated recrystallizations appeared in form of elongated plates which contained no crystal water. In a sealed capillary tube the air-dry substance decomposed with effervescence at 230–233°C.

Rotations.

The rotations were measured: (a) in aqueous solution, (b) in a solution of 10 per cent hydrochloric acid, (c) in a 5 per cent aqueous solution of ammonia, (d) in a 2 per cent aqueous solution of caustic soda, and (e) in a 5 per cent solution of the same.

Guanosin- and adenosinphosphoric acids showed a minimum levorotation in hydrochloric acid solution, which increased in water and in aqueous ammonia, and reached a maximum in an aqueous solution of sodium hydroxide.

Cytidinphosphoric acid showed a maximum dextrorotation in aqueous solution, successively decreasing in aqueous ammonia, hydrochloric acid, 2 per cent sodium hydroxide, and turned levorotary in 10 per cent sodium hydroxide.

Uridinphosphoric acid and its ammonium salt changed their optical rotation in the same direction as the preceding substance.

The changes in the optical rotation probably are the resultants of more than one factor. Among these the tautomeric changes in the basic radical of the substance possibly play an important part. Indeed, adenosin and uridin showed the same character of optical rotation as the corresponding nucleotides. On the other hand, the molecular rotation of the nucleoside and of the nucleotide are not identical.

EXPERIMENTAL.

Guanosinphosphoric Acid.—10 gm. of the crystalline material (No. 26) described in a previous communication⁵ were recrystallized out of water. One part of the substance was suspended in thirty parts of water and the water kept boiling until solution was completed. The solution was allowed to stand at room temperature (about 25°C.) over night. The yield of recrystallized material was 7.5 gm. (No. 291). It was planned to continue recrystallization until a constant optical rotation of the substance was attained. On the first recrystallization the specific rotation remained without change. No. 291 was recrystallized once more out of 200 cc. of water in the same manner as No. 26. The resulting material showed no change in its optical rotation. The air-dry substance heated in a sealed capillary tube contracted and turned semitransparent at 175°C. (corrected) and decomposed at 180°C.

486 Nucleotides from Yeast Nucleic Acid

0.1168 gm. of the air-dry substance on drying to constant weight under diminished pressure at the temperature of xylene vapor lost 0.1112 gm. in weight.

	Calculated for $C_{10}H_{14}N_3PO_3 + 2H_2O$.	Found.
	per cent	per cent
H ₂ O.....	9.47	9.67

The dry substance (No. 312) analyzed as follows:

0.1056 gm. of the substance gave 0.1312 gm. of CO₂ and 0.0168 gm. of H₂O.

0.1807 gm. of the substance employed for Kjeldahl nitrogen estimation required for neutralization 34.85 cc. of 0.1 N acid.

0.2710 gm. of the substance gave 0.0839 gm. of Mg₂P₂O₇.

	Calculated for $C_{10}H_{14}N_3PO_3$.	Found.
	per cent	per cent
C.....	33.05	33.89
H.....	3.89	3.90
N.....	19.22	19.25
P.....	8.55	8.62

Rotation of the substance in aqueous solution:

$$\text{No. 26} \quad [\alpha]_D^{25} = \frac{-0.15 \times 100}{1 \times 2} = -7.5^\circ$$

$$\text{No. 291} \quad [\alpha]_D^{25} = \frac{-0.15 \times 100}{1 \times 2} = -7.5^\circ$$

$$\text{No. 312} \quad [\alpha]_D^{25} = \frac{-0.16 \times 100}{1 \times 2} = -8.0^\circ$$

Rotation of the air-dry substance in 10 per cent hydrochloric acid:

$$\text{No. 312} \quad [\alpha]_D^{25} = \frac{+0.03 \times 100}{1 \times 2} = +1.5^\circ$$

Rotation of the air-dry substance in 5 per cent aqueous ammonia solution:

$$\text{No. 312} \quad [\alpha]_D^{20} = \frac{-0.88 \times 100}{1 \times 2} = -44.0^\circ$$

The rotation of the substance in 2 per cent aqueous caustic soda was as follows:

$$[\alpha]_D^{25} = \frac{-1.14 \times 100}{1 \times 2} = -57.0^\circ$$

In 5 per cent of the same:

$$[\alpha]_D^{25} = \frac{-1.30 \times 100}{1 \times 2} = -65.0^\circ$$

Adenosinphosphoric acid is the most insoluble of the four nucleotides. 23 gm. of the substance (No. 286) were suspended in 1 liter of hot water and the water was kept boiling for some time and since the substance did not dissolve readily dilute ammonia was added gradually until solution was completed. The hot solution was rendered slightly acid to litmus by means of acetic acid and allowed to stand at room temperature over night. A crystalline deposit (No. 282) formed.

The precipitate thus formed was recrystallized out of 600 cc. of water and allowed to crystallize over night. A crystalline deposit was formed. The yield was 7.5 gm. (No. 290). These were again recrystallized out of hot water. The yield was 5 gm. (No. 306). On heating in a sealed capillary tube the substance decomposed at 195°C. (corrected).

Analysis of the substance:

0.1225 gm. of the substance on drying under diminished pressure at the temperature of xylene vapor lost 0.0069 gm. of water.

	Calculated for $C_{10}H_{13}N_5PO_7 + H_2O$.	Found.
	per cent	per cent
H ₂ O.....	4.90	5.20

Several samples were analyzed with the same result whereas the first two samples were analyzed for the anhydrous substance.

The dry substance (No. 306) analyzed as follows:

0.1256 gm. of the substance gave on combustion 0.1599 gm. of CO₂ and 0.0456 gm. of H₂O.

0.0948 gm. of the substance employed for Kjeldahl nitrogen estimation required for neutralization 13.56 cc. of 0.1 N acid.

0.2844 gm. of the substance gave 0.0913 gm. of Mg₂P₂O₇.

	Calculated for $C_{10}H_{11}N_5PO_7$.	Found.
	per cent	per cent
C.....	34.57	34.71
H.....	4.07	4.06
N.....	20.17	20.13
P.....	8.94	9.04

Rotation of the substance in 1 per cent aqueous solution in 2 dm. tube:

$$\text{No. 306} \quad [\alpha]_{\text{D}}^{50} = \frac{-0.81 \times 100}{2 \times 1} = -40.5^{\circ}$$

Since the substance is only little soluble in water the readings of the substances in process of their purification were taken in 5 per cent aqueous ammonia.

Rotation in 5 per cent aqueous ammonia solution:

$$\text{No. 282} \quad [\alpha]_{\text{D}}^{50} = \frac{-0.81 \times 100}{1 \times 2} = -40.5^{\circ}$$

$$\text{No. 290} \quad [\alpha]_{\text{D}}^{50} = \frac{-0.89 \times 100}{1 \times 2} = -44.5^{\circ}$$

$$\text{No. 306} \quad [\alpha]_{\text{D}}^{50} = \frac{-0.83 \times 100}{1 \times 2} = -41.5^{\circ}$$

The slight variation might be due to variation in the moisture of the substance.

Rotation in a solution of 10 per cent hydrochloric acid:

$$\text{No. 306} \quad [\alpha]_{\text{D}}^{20} = \frac{-0.76 \times 100}{1 \times 2} = -38.00^{\circ}$$

The rotation of the substance in 2 per cent aqueous caustic soda was as follows:

$$[\alpha]_{\text{D}}^{20} = \frac{-1.19 \times 100}{1 \times 2} = -59.5^{\circ}$$

In 5 per cent of the same:

$$[\alpha]_{\text{D}}^{20} = \frac{-1.32 \times 100}{1 \times 2} = -66.0^{\circ}$$

Cytidinphosphoric Acid.—The starting material was a mixture of cytidin- and adenosinphosphoric acid, prepared in the manner described in the previous paper. The original optical rotation was $[\alpha]_{\text{D}}^{20} = +25$. By recrystallization out of 50 per cent alcohol finally a substance was obtained with $[\alpha]_{\text{D}}^{20} = +40$. 10.0 gm. of this material (No. 270) were dissolved in 500 cc. of boiling water and to the solution 500.0 cc. of 99.8 per cent alcohol were added. Soon heavy crystals began to settle out and the crystallization was allowed to proceed 48 hours. The yield of the crystals was 7.5 gm. (No. 280). This material was then dissolved in

400 cc. of boiling water and 400 cc. of 99.8 per cent alcohol were added to the solution. The crystallization proceeded as above. The yield of the crystals was 6.0 gm. (No. 285). These 6.0 gm. were dissolved in 350 cc. of boiling water and to the solution 150.0 cc. of 99.8 per cent alcohol were added. The yield of the final material (No. 289) was 5.0 gm. The crystal form is reproduced in Fig. 4.

The substance in sealed capillary tube decomposed with effervescence at 230–233°C. (corrected). (Heating slow.)

The analysis of the substance was as follows:

On drying under diminished pressure at the temperature of xylene vapor the substance lost 0.8 per cent in weight.

0.1123 gm. of the dry substance gave 0.1374 gm. of CO₂ and 0.0442 gm. of H₂O.

0.0992 gm. of the dry substance employed for Kjeldahl nitrogen estimation required for neutralization 9.23 cc. of 0.1-N acid.

0.2976 gm. of the substance gave 0.1014 gm. of Mg₂P₂O₇.

	Calculated for C ₂ H ₁₄ N ₃ PO ₈ , <i>per cent</i>	Found, <i>per cent</i>
C.....	33.42	33.36
H.....	4.37	4.41
N.....	13.00	13.03
P.....	9.61	9.50

The optical rotation was as follows:

In aqueous solution:

$$\text{No. 270} \quad [\alpha]_D^{20} = \frac{+ 0.80 \times 100}{1 \times 2} = + 40.0^\circ$$

$$\text{No. 285} \quad [\alpha]_D^{20} = \frac{+ 0.97 \times 100}{1 \times 2} = + 48.5^\circ$$

$$\text{No. 289} \quad [\alpha]_D^{20} = \frac{+ 0.95 \times 100}{1 \times 2} = + 47.5^\circ$$

In 10 per cent hydrochloric acid solution:

$$\text{No. 289} \quad [\alpha]_D^{25} = \frac{+ 0.52 \times 100}{1 \times 2} = + 26.0^\circ$$

In 5 per cent ammoniacal solution:

$$\text{No. 289} \quad [\alpha]_D^{25} = \frac{+ 0.89 \times 100}{1 \times 2} = + 44.5^\circ$$

In 2 per cent sodium hydroxide solution:

$$\text{No. 289} \quad [\alpha]_D^{25} = \frac{+ 0.51 \times 100}{1 \times 2} = + 25.5^\circ$$

In 5 per cent solution of the same:

$$[\alpha]_D^{25} = \frac{+ 0.02 \times 100}{1 \times 2} = + 1.0^\circ$$

In 10 per cent solution of the same:

$$[\alpha]_D^{25} = \frac{- 0.42 \times 100}{1 \times 2} = - 21.0^\circ$$

Uridinphosphoric Acid.—The material described in a previous communication was dissolved in boiling methyl alcohol and the solution was allowed to stand in a desiccator over sulfuric acid. On standing, after a considerable part of the alcohol evaporated, heavy crystals settled out on the walls of the dish. The crystallization proceeded very slowly.

The substance melted in sealed tube with decomposition at M.P. = 198.5°C. (corrected).

The analysis of the substance was as follows:

0.1000 gm. of the substance used for Kjeldahl nitrogen estimation required for neutralization 5.97 cc. of 0.1 N acid.

	Calculated for $C_9H_{13}N_2PO_9$	Found.
	per cent	per cent
N.....	8.64	8.36

The rotation of the substance (No. 343) was as follows:

In aqueous solution:

$$[\alpha]_D^{25} = \frac{+ 0.19 \times 100}{1 \times 2} = + 9.5^\circ$$

In 2 per cent solution of sodium hydroxide:

$$[\alpha]_D^{25} = \frac{+ 0.13 \times 100}{1 \times 2} = + 6.5^\circ$$

In 5 per cent solution of sodium hydroxide:

$$[\alpha]_D^{25} = \frac{- 0.30 \times 100}{1 \times 2} = - 15.0^\circ$$

Monoammonium Salt of Uridinphosphoric Acid.—The crystalline material described in a previous communication was dissolved in a minimum amount of water and to the solution 20 volumes of methyl alcohol were added. The solution was allowed to stand at room temperature. After several days on walls of the flask a sediment formed, which consisted of fine curved felt-forming needles (No. 254). In the mother liquor, on further standing, a third precipitate formed. The crystal form is reproduced in Fig. 3.

The substance when heated in a sealed capillary tube contracted and turned semitransparent at 200°C. (corrected) and decomposed with effervescence at 240°C.

The analysis of the substance was as follows:

0.1204 gm. of the substance gave on combustion 0.1417 gm. of CO₂ and 0.0514 gm. of H₂O.

0.1964 gm. of the substance employed for Kjeldahl nitrogen estimation required for neutralization 17.24 cc. of 0.1 N acid.

0.1964 gm. of the substance gave 0.0650 gm. of Mg₂P₂O₇.

	Calculated for C ₉ H ₁₃ N ₂ PO ₈ .	Found.
	<i>per cent</i>	<i>per cent</i>
C.....	31.66	32.09
H.....	4.73	4.77
N.....	12.32	12.30
P.....	9.58	9.15

The optical rotation of the substance was as follows:
In aqueous solution:

$$\text{No. 255} \quad [\alpha]_{\text{D}}^{50} = \frac{+ 0.21 \times 100}{1 \times 2} = + 10.5^{\circ}$$

In 10 per cent hydrochloric acid solution:

$$\text{No. 255} \quad [\alpha]_{\text{D}}^{25} = \frac{+ 0.05 \times 100}{1 \times 2} = + 2.5^{\circ}$$

In 5 per cent ammoniacal solution:

$$\text{No. 255} \quad [\alpha]_{\text{D}}^{25} = \frac{+ 0.28 \times 100}{1 \times 2} = + 14.0^{\circ}$$

The rotation of the substance in 2 per cent aqueous sodium hydroxide was:

$$[\alpha]_D^{20} = \frac{+ 0.03 \times 100}{1 \times 2} = + 1.5^\circ$$

In 5 per cent solution of the same:

$$[\alpha]_D^{20} = \frac{- 0.32 \times 100}{1 \times 2} = - 16.0^\circ$$

In 10 per cent solution of the same:

$$[\alpha]_D^{20} = \frac{- 0.52 \times 100}{1 \times 2} = - 26.0^\circ$$

The optical rotation of adenosin was as follows:

In aqueous solution:

$$[\alpha]_D^{20} = \frac{- 1.20 \times 100}{1 \times 2} = - 60.0^\circ$$

In 10 per cent solution of hydrochloric acid:

$$[\alpha]_D^{20} = \frac{- 0.87 \times 100}{1 \times 2} = - 43.5^\circ$$

In 5 per cent solution of sodium hydroxide:

$$[\alpha]_D^{20} = \frac{- 1.37 \times 100}{1 \times 2} = - 68.5^\circ$$

The optical rotation of uridin was as follows:

In aqueous solution:

$$[\alpha]_D^{20} = \frac{+ 0.08 \times 100}{1 \times 2} = + 4.0^\circ$$

In 10 per cent solution of hydrochloric acid:

$$[\alpha]_D^{20} = \frac{+ 0.10 \times 100}{1 \times 2} = + 5.0^\circ$$

In 5 per cent solution of sodium hydroxide:

$$[\alpha]_D^{20} = \frac{- 0.12 \times 100}{1 \times 2} = - 6.0^\circ$$

EXPLANATION OF PLATES.

PLATE 4.

- FIG. 1. Crystals of adenosinphosphoric acid.
FIG. 2. Crystals of guanosinphosphoric acid.

PLATE 5.

- FIG. 3. Crystals of monoammonium salt of uridinphosphoric acid.
FIG. 4. Crystals of cytidinphosphoric acid.

494

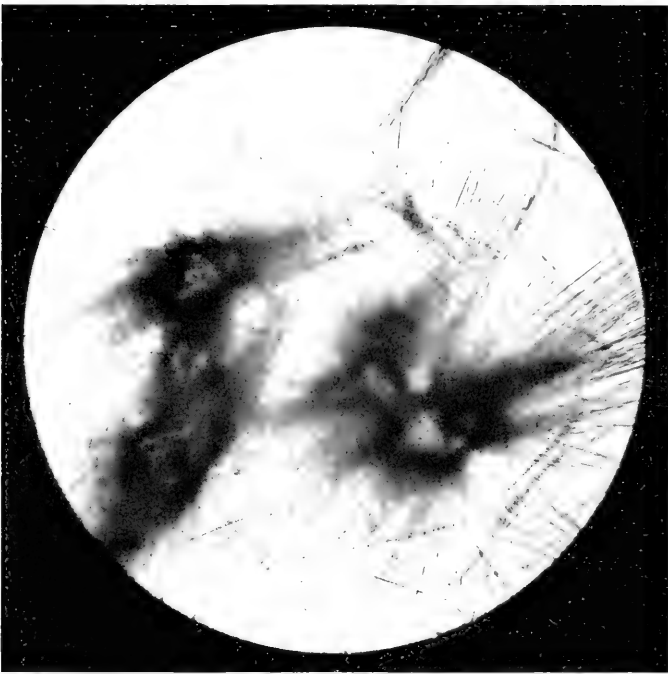

FIG. 1.



FIG. 2.

(Levene: Nucleotides from yeast nucleic acid.)



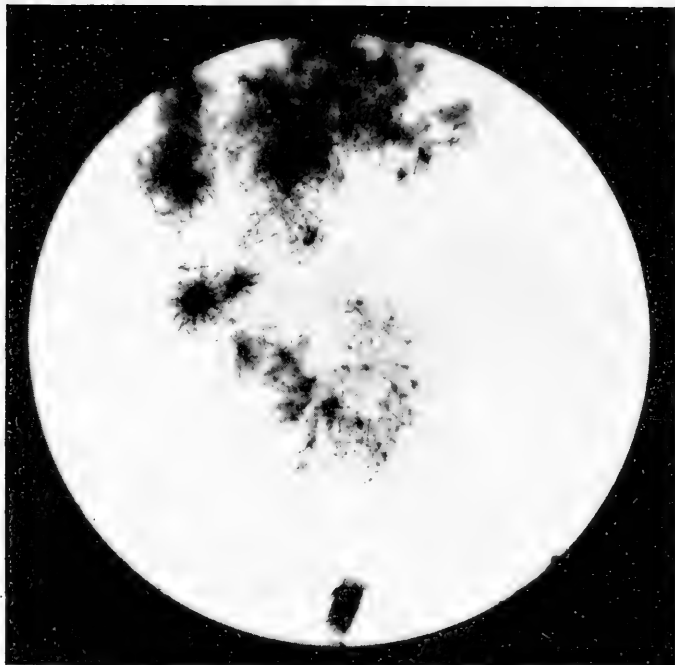

FIG. 3.



FIG. 4.

(Levene: Nucleotides from yeast nucleic acid.)



RUTIN, THE FLAVONE PIGMENT OF *ESCHOLTZIA CALIFORNICA* CHAM.*

BY CHARLES E. SANDO AND H. H. BARTLETT.

(From the Office of Physiological and Fermentation Investigations, Bureau of Plant Industry, and the Department of Botany, University of Michigan, Ann Arbor.)

PLATES 6 AND 7.

(Received for publication, February 7, 1920.)

The simple chemical relationship between the flavonol and anthocyanin series of plant pigments, suggested by Combes¹ and Everest,² but not proved until Willstätter and Mallison³ actually produced cyanidin from quercetin by reduction in acid solution, has led to considerable speculation as to the genetical and physiological interrelations of these compounds. There is some evidence that the anthocyanins are produced in the plant from the corresponding flavonols, and not by direct synthesis. Everest,⁴ for example, has shown that glucosides of the chemically related pair myricetin and delphinidin occur side by side in purple-black forms of *Viola*. Before far reaching conclusions are drawn, however, it will be necessary to isolate, or otherwise identify, the pigments of a large number of species. It goes without saying that the best material for this purpose will be afforded by species whose color varieties are capable of genetic analysis or by species in which the relations between flavone and anthocyanin are capable of experimental modification.

The genus *Escholtzia*, abundantly distributed in California, and common in cultivation, contains garden forms with $\frac{1}{2}$ yellow, golden yellow, pale yellow, white, carmine, and rose flowers. It

*Published by permission of the Secretary of Agriculture.

¹ Combes, R., *Compt. rend. Acad.*, 1913, clvii, 1002, 1454.

² Everest, A. E., *Proc. Roy. Soc. London, Series B*, 1913-14, lxxxvii, 444.

³ Willstätter, R., and Mallison, H., *Sitzungsb. kais. Akad. Wissensch.*, 1914, 769.

⁴ Everest, A. E., *Proc. Roy. Soc. London, Series B*, 1917-18, xc, 251.

would provide ideal material for combined genetical and biochemical investigation providing the pigments concerned were present in large quantity and easily isolable. With this idea in mind, the writers obtained for preliminary work a large quantity of petals of wild *Escholtzia*, gathered by Mr. W. W. Wagener in the vicinity of Palo Alto, California. We have called the material *Escholtzia californica* Cham., using this specific name in the broad sense, for it was of course out of the question to observe close specific or varietal differences in gathering wild material of this polymorphic genus.

Preparation and Properties of Rutin.

The air-dried petals afforded an abundant yield of the glucoside rutin, quercetin glucoso-rhamnoside. They were first extracted for several days with ether, to remove fats, carotinoids, etc., and then with ethyl alcohol. The alcoholic solution was evaporated to small bulk, poured into water, and the remaining alcohol boiled off. The crude rutin, which came down as a copious crystalline precipitate, was collected on a Buchner funnel, washed with water, dried, extracted with ether until no colored impurities were removed, and finally purified by recrystallization from a large volume of hot water. By this method 7.13 gm. of rutin (dried at 140°C.) were obtained from 150 gm. of air-dried petals.

According to Perkin and Everest,⁵ rutin "is said to melt above 190°." Schmidt⁶ gives 188–190°. Our preparation began to sinter at 186° and melted at 190–192°C. (uncorrected). The color of the anhydrous compound (dried at 150–160°), as ascertained by comparison with Ridgway's standards,⁷ was primrose-yellow; the streak was pale green-yellow. As obtained by crystallization from hot water *Escholtzia* rutin formed microscopically fine, very dense, acute-based tufts of silky crystals (Fig. 1).

Water of crystallization was determined by exposing a sample of the glucoside to a moist atmosphere under a bell jar until it

⁵ Perkin, A. G., and Everest, A. E., *The natural organic colouring matters*, London and New York, 1918, 197.

⁶ Schmidt, E., *Arch. Pharm.*, 1908, cexlvi, 214.

⁷ Ridgway, R., *Color standards and color nomenclature*, Washington, 1912.

came to constant weight. It was then dried at 160° for 12 hours. The loss of water from 2.2548 gm. of glucoside was 0.1868 gm., or 8.28 per cent, according satisfactorily with the 8.13 per cent calculated from $C_{27}H_{30}O_{16} \cdot 3H_2O$, the accepted formula of rutin.

Identification of Quercetin.

Hydrolysis resolves rutin into one molecule each of quercetin, rhamnose, and glucose. Our anhydrous preparation, boiled with approximately 5 per cent sulfuric acid, gave quercetin yields of 0.5354 gm. and 0.6177 gm. from samples weighing 1.0812 gm. and 1.2460 gm., respectively. These figures correspond to 49.51 and 49.57 per cent. Theory requires 49.51 per cent. The

TABLE I.

	Weight of sample.	CO ₂	H ₂ O	C	H	O
	gm.	gm.	gm.	per cent	per cent	per cent
Rutin.....	0.1645	0.3204	0.0766	53.12	5.22	41.66
	0.1810	0.3528	0.0840	53.15	5.20	41.65
Quercetin.....	0.1694	0.3709	0.0490	59.71	3.24	37.05
	0.1759	0.3854	0.0532	59.74	3.39	36.87
Penta-acetylquercetin.....	0.1220	0.2634	0.0423	58.88	3.89	37.23
	0.1106	0.2388	0.0386	58.88	3.91	37.21

crystalline quercetin (Fig. 2) was washed with cold water and dried at 140°C. It conformed in physical characteristics with quercetin from other sources. The crystals were citron-yellow; the streak light greenish yellow. In order to prevent decomposition of the material below the melting point, the bath (melted acid potassium sulfate) was heated to 300° before the sample for determination of melting point was introduced. Rosenthaler⁸ states that quercetin melts with partial decomposition at 310°. Our material darkened, but did not melt, between 300 and 305°. The melting point was not so sharp as might have been wished, but melting was complete at 310°. Wunderlich⁹ gives 305–310°.

⁸ Rosenthaler, L., *Der Nachweis organischer Verbindungen*, Stuttgart, 813.

⁹ Wunderlich, A., *Arch. Pharm.*, 1908, cclxvi, 224, 241, 256.

A satisfactory identification of the compound was secured, however, by acetylation. It gave penta-acetylquercetin, melting at 189–191°. Perkin and Hummel¹⁰ found 190–191°. Samples of the latter, weighing 0.7638 and 0.5704 gm., hydrolyzed by hydrochloric acid in glacial acetic acid, gave quercetin yields of 0.4512 and 0.3376 gm., corresponding to 59.07 and 59.18 per cent. Theory requires 58.98 per cent. Combustions were made of rutin and of the quercetin and acetylquercetin derived from it. The results, concordant and agreeing well with expectation, are given in Tables I and II.

When treated with sulfuric acid in boiling glacial acetic acid, quercetin forms a finely crystalline orange-vermilion acid addition product, $C_{15}H_{10}O_7 \cdot H_2SO_4$, from which the quercetin is easily regenerated by simple suspension in water. A sample of the

TABLE II.

	Rutin.		Quercetin.		Penta-acetylquercetin.	
	Found.	Expected.	Found.	Expected.	Found.	Expected.
	<i>per cent</i>	<i>per cent</i>	<i>per cent</i>	<i>per cent</i>	<i>per cent</i>	<i>per cent</i>
C.....	53.14	53.10	59.73	59.59	58.88	58.59
H.....	5.21	4.95	3.32	3.34	3.90	3.90
O.....	41.65	41.95	36.95	37.07	37.22	37.51

sulfate weighing 0.2714 gm., dried at 100°, gave 0.2034 gm. of recovered quercetin, or 74.94 per cent. Theory requires 75.5 per cent.

The Sugars.

In view of the perfect agreement of the analytical results with the figures for rutin, complete identification required only the determination of the sugars resulting from hydrolysis. The literature of rutin and its synonyms, violaquercetrin, osyritrin, myrticolorin, *etc.*, shows that for many years the occurrence of glucose in the presence of rhamnose was overlooked, or *vice versa*. Following a modification of Perkin's procedure,¹¹ we separated pure glucosazone and rhamnosazone from the mixed osazones,

¹⁰ Perkin, A. G., and Hummel, J. J., *J. Chem. Soc.*, 1896, lxix, 1295.

¹¹ Perkin, A. G., *J. Chem. Soc.*, 1910, xevii, 1776.

using the differential solubility of the compounds in acetone for the primary separation, following with recrystallization from 5 per cent pyridine in water and then from 20 per cent alcohol for final purification. In this manner rhamnosazone, melting at 181–182°, and glucosazone, melting at 205–207°, were obtained. Recrystallized from 20 per cent alcohol, under identical conditions, the crystal forms were characteristically different, as shown in Figs. 3 and 4. We were unable to distinguish two types of crystals in the mixture of osazones before fractionation by acetone, but after purification the glucosazone formed typical radiate groups of short, unbranched needles, and the rhamnosazone bifasciculate clusters of longer, more slender, branching needles.

Distribution of Rutin.

All the plants which have been reported to contain rutin have been critically examined in recent years either by Schmidt⁶ and Wunderlich⁹ or Perkin.¹¹ Adding *Escholtzia* to the list, the known distribution of rutin is now as follows:

Santalaceae; leaves of *Osyris compressa*,

Polygonaceae; entire herb, but chiefly the flowers, of *Fagopyrum esculentum*,

Papaveraceae; petals of *Escholtzia californica*,

Capparidaceae; flower buds of *Capparis spinosa*,

Leguminosae; flower buds of *Sophora japonica*,

Rutaceae; leaves of *Ruta graveolens*,

Violaceae; flowers of *Viola tricolor*,

Myrtaceae; leaves of *Eucalyptus macrorhyncha*,

Globulariaceae; leaves of *Globularia alypum*.

Only *Capparis* is doubtful, the rutin from this source differing from that of *Ruta*, etc. in sintering 10° below the usual temperature, regardless of every effort to purify the material completely. With the exception of *Globularia*, all the plants known to contain rutin fall within the subclass Archichlamideae of the Dicotyledones.

SUMMARY.

The petals of *Escholtzia californica* contain nearly 5 per cent of rutin (quercetin glucoso-rhamnoside). In view of the great range of flower colors in *Escholtzia*, from golden yellow to white, and from white to rose, this genus would appear to afford especially suitable material for study of the physiological and genetic relationships of the flavonol and anthocyanin pigments. It is hoped that the problems will interest workers who are advantageously located for carrying out both garden and laboratory studies.

Notwithstanding the brilliant work of Willstätter in showing the chemical relation of the anthocyanins and the flavonol pigments, it is quite true, as Wheldale¹² has said, that in order to prove their relation in nature it is necessary to know which flavone accompanies which anthocyanin in a considerable number of plants. It would conserve effort in solving the problem if the flavones were isolated and identified in all the plants in which Willstätter determined the anthocyanins, and, conversely, if those plants in which the yellow pigments are well known were studied with respect to the anthocyanins. That it will be difficult to work out the relation, and that it cannot be done except by collaboration between chemists and geneticists, is shown by the fact that Sutton's "Black Knight" pansy, a variety of *Viola tricolor*, a species well known for its great range of flower colors, has been shown by Everest to contain glucosides of the pair myricetin-delphinidin, whereas one would have expected from the well established occurrence of rutin in this species that the pair quercetin-cyanidin would have been the first to be detected. The share of the geneticist in the final elucidation of the pigment situation must be to provide the chemist with material of known factorial composition.

¹² Wheldale, M., *The anthocyanin pigments of plants*, Cambridge, 1916, 15.

EXPLANATION OF PLATES.

PLATE 6.

FIG. 1. *Escholtzia* rutin, crystallized from hot water ($\times 90$).

FIG. 2. Quercetin from *Escholtzia* rutin, as obtained by hydrolysis of the rutin with boiling 5 per cent sulfuric acid ($\times 90$).

PLATE 7.

FIG. 3. Phenylglucosazone, separated from phenylrhamnosazone by acetone and purified by recrystallization. The crystals were obtained by cooling of a hot solution in 20 per cent alcohol. Under exactly the same conditions phenylrhamnosazone crystallized as in Fig. 4 ($\times 90$).

FIG. 4. Phenylrhamnosazone, crystallized from hot 20 per cent alcohol ($\times 90$).

Set

5522



FIG. 1.



FIG. 2.

(Sando and Bartlett: Rutin.)



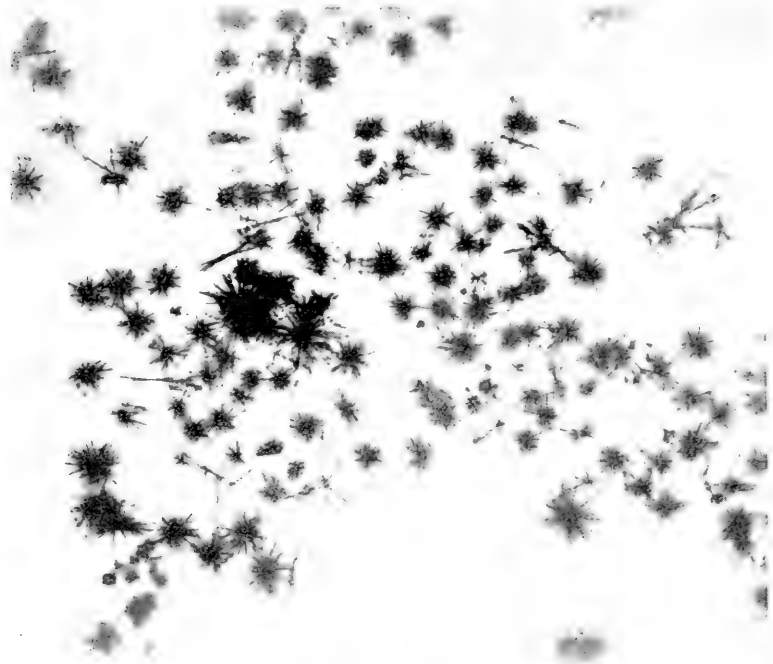

FIG. 3.

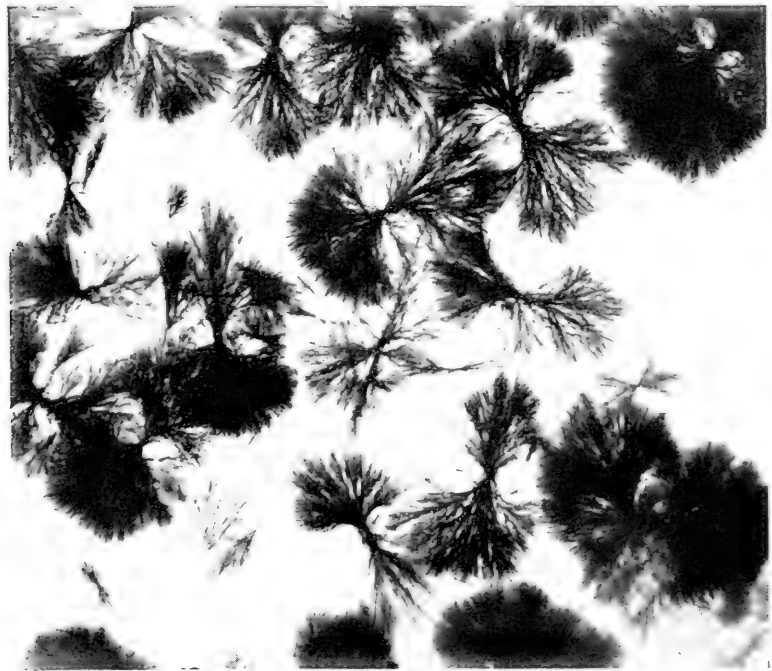

FIG. 4.

(Sando and Bartlett: Rutin.)



THE FORMATION OF ACETONE BODIES FOLLOWING
ETHER ANESTHESIA AND THEIR RELATION
TO THE PLASMA BICARBONATE.

BY JAMES J. SHORT.

*(From the Laboratory of Pathological Chemistry and Department of Medicine,
New York Post-Graduate Medical School and Hospital,
New York.)*

(Received for publication, February 10, 1920.)

It is a common observation that urine voided following ether anesthesia gives positive sodium nitroprusside and ferric chloride tests for acetone bodies; also, that as a result of the anesthetic there is a decrease in the CO_2 -combining power of the blood plasma. Because of this coincidence it has been believed by many that the formation of acetone bodies accounts for the decreased alkaline reserve. Some observations were recently made by Reimann and Bloom (1) which appeared to confirm this theory. They studied the CO_2 -combining power, together with the total blood acetone bodies, before and after ether anesthesia in a series of 60 patients and concluded that "blood acetone bodies account for 20 to 100 per cent of the bicarbonate fall observed, on an average for 60 per cent."

In the course of some work done to determine the frequency of acidosis in babies in a number of conditions, it was thought desirable to carry out some determinations of the blood acetone bodies, and for this purpose the method of Van Slyke and Fitz (2) was selected. The method is a gravimetric one and depends on the formation of a mercury-acetone complex which results from boiling mercuric sulfate, sulfuric acid, and potassium dichromate reagents in certain definite concentration with protein-free blood filtrate. Since certain substances beside acetone, including alcohol, give precipitates (2), it was necessary, if postoperative bloods were to be analyzed, to learn whether or not ether would also give a precipitate under the conditions of the determination.

This proved to be the case, the precipitate forming only after boiling with the 5 per cent potassium dichromate reagent, which was reduced, giving a green color. This precipitate was very similar in appearance to the acetone-mercury compound, and like the latter gave a positive iodoform test (Lieben's). From these preliminary observations it seemed necessary to make a study of the acetone bodies before and after anesthesia on adult cases. The general plan was to observe the relation existing between the CO_2 -combining power of the blood and the β -hydroxybutyric acid, since this substance is in major part responsible for decrease in alkaline reserve when the decrease is due to a ketosis (3). It was also desired to observe the relative proportions of acetone and acetoacetic acid and β -hydroxybutyric acid, since it was thought that this would throw some light on the rôle of ether in the production of acetone bodies. The ether contained in the postoperative blood specimens was removed from the filtrate at the end of 30 minutes boiling with the reagents by passing a current of air through the hot liquid for 10 minutes, after the acetone precipitate had been filtered off. This was found by experiment to remove completely all the ether. After cooling, 160 cc. of the fluid were returned to the flask and 5 cc. of 5 per cent dichromate were added after boiling had commenced. The CO_2 -combining power was determined by the Van Slyke method (4).

The average of the preoperative values given in Table I, when expressed as total acetone bodies, is about 1 mg. per 100 cc. higher than that stated as the upper normal limit by Van Slyke and Fitz (2); the majority of those for acetoacetic acid and acetone (as acetone) and for β -hydroxybutyric acid are in agreement with those obtained by Marriott (5) for normal blood.¹ The average value for acetoacetic acid and acetone (as acetone) was 0.91 mg., that for β -acid 6.12 mg. per 100 cc. None of these patients was known to be suffering from a ketosis at the time these bloods were taken, the urines of all, except three which were not tested, being found negative to the ferric chloride and sodium nitro-

¹ It should be noted that β -hydroxybutyric acid values in Tables I, II, and III are expressed in terms of β -hydroxybutyric acid, while those given by Marriott are in terms of acetone. Conversion of the β -acid values to terms of acetone may be made by dividing by 2.36.

Patient.	Sex.	Age.	Preoperative.				Postoperative.				Remarks.
			Urine		100 cc. of blood.		Urine.		100 cc. of blood.		
			Acetone bodies.*	Acetoacetic acid (as acetone).	β -hydroxybutyric acid.	CO_2 -combining power.	Nature of collection.	Acetone bodies.	Acetoacetic acid (as acetone).	β -hydroxybutyric acid.	
	mg.	mg.	per cent	min.	mg.	mg.	mg.	per cent			
1. J. R.	♂	25		2.4	8.04	21	1.0	18.6	47.5	Subacute appendicitis. Appendectomy.	
2. S. J.	♂	28	Negative.	0.0	3.55	30	1.2	3.52	47.5	Fistula repaired. Hemorrhoidectomy.	
3. E. C.	♂	36	"	2.28	3.55	26	1.0	12.8	48.5	Hemorrhoidectomy.	
4. W. D.	♂	37	"	1.0	4.28	40	1.0	5.53	59.8	Inoperable carcinoma of stomach.	
5. E. C.	♀	32	"	0.6	6.62	45	1.8	9.94	44.7	Femoral hernia.	
6. E. P.	♂	74		0.4	2.36	40	0.75	0.0	44.7	Carcinoma of bladder.	
7. P. O.	♂	55	Negative.	0.8	4.74	40	2.2	6.63	48.5	Hemorrhoidectomy.	
8. M. B.	♀	36	"	0.2	24.6	70	0.6	13.4	40.0	Carcinoma of breast.	
9. J. D.	♀	77	"	1.4	1.51	110	2.0	14.15		Breast amputation for carcinoma.	
10. W. C.	♂	50		0.8	7.0	43	0.4	16.6	51.9	Inoperable carcinoma of bladder.	
11. M. M.	♀	27	Negative.	0.6	5.2	47	0.6	3.55	50.0	Pericholecystic adhesions removed. Appendectomy.	
12. M. P.	♂	29	"	0.48	2.0	77	1.0	4.68	46.2	Gastroenterostomy. Appendectomy. Removal of adhesions.	

* Ferric chloride and sodium nitroprusside tests.

The condition of all the above patients was good immediately after operation, and all had an uneventful recovery from the anesthetic.

prusside tests. The average duration of administration of ether for the series was 48 minutes. The average postoperative value for acetoacetic acid and acetone was 1.13 mg., and for β -acid 9.2 mg., per 100 cc. The average preoperative CO_2 -combining power was 57.3, postoperative, 48.6 volumes per cent. The average increase of acetoacetic acid and acetone was 0.22 mg., of β -acid 3.08 mg., per 100 cc. In several instances, but particularly in the case of M. B., there was apparently an actual decrease in the acetone bodies following anesthesia. As will be noted, the preoperative β -acid value for M. B. was exceptionally high; unfortunately, enough blood was not available or obtainable for a duplicate determination to check this result. In all cases the β -acid values were affected by the anesthetic to a greater extent than the acetoacetic acid and acetone values, the latter remaining more constant. The most significant rise in the β -acid value was seen in the case of J. D. where anesthesia was prolonged for 110 minutes, but in no case was the increase sufficient immediately after the anesthetic to become dangerous to the patient, as it is said that diabetics under good control show 10 to 40 mg. of acetone bodies (as acetone) per 100 cc. of blood (2). Unfortunately, sufficient blood was not obtained from J. D. following anesthesia for a determination of the CO_2 -combining power.

It would not only appear, from the figures in Table I, that the increased values for acetone bodies could have had little to do with the decreased bicarbonate, but it is also somewhat doubtful if the figures obtained on postoperative bloods in all cases represent merely the acetone bodies. It was suspected that, since the blood fat content is increased as a result of ether administration (6), this might become an interfering substance as its solution in the ether of the blood would permit it to escape through the filter during the removal of the precipitated proteins; and, since ether could readily be detected in the filtrate, a few experiments were carried out which confirmed this suspicion. At first, fat shaken with 25 cc. of water (in order to have the usual concentration of reagents) was boiled with the reagents including dichromate for $1\frac{1}{2}$ hours and a precipitate was recovered. Then some fat, of such quantity that, when added to 10 cc. of normal blood, it would approximately double its fat content, was thoroughly mixed with a 10 cc. portion of a blood specimen; and the

same amount of fat in solution in a small quantity of ether was thoroughly mixed with another 10 cc. portion of the same blood specimen. Determinations of total acetone bodies were then carried out in the usual manner, with the result that the specimen containing the ether yielded more than double the amount of precipitate obtained from the other. Since ether itself forms a precipitate when boiled with the reagents in the presence of dichromate, and since in this experiment the ether was not removed by aeration as previously described, the experiment was repeated, adding the same amount of fat, the fluid being aerated after 30 minutes boiling without dichromate to precipitate the preformed acetoacetic acid and acetone present in the blood. From the specimen to which fat alone was added, no increase in precipitate was obtained over that yielded by the blood alone, the figures being nearly identical. The precipitate from that to which both fat and ether were added, however, was over twelve times as great.

Following this work two series of determinations of acetone bodies, CO_2 -combining power, and total fat were made on the bloods of two patients before and after ether anesthesia. The fat determinations were carried out by Bloor's nephelometric method (7). From the first patient blood and urine specimens were collected simultaneously at hourly intervals for 3 hours, and from the second at 2 hour intervals for 6 hours. The urines were likewise analyzed for acetone bodies. The results are expressed in Tables II and III.

The figures in Table II express rather clearly the time necessary for any significant increase in concentration of blood acetone bodies. At 3.00 p.m., immediately after the cessation of 47 minutes of ether administration, there was no increase. At 4.00 p.m. there was apparently an increase in preformed acetoacetic acid and acetone, but still no increase in the β -acid. At 5.00 and at 6.00 p.m., however, the β -acid determinations showed a marked and distinct increase, rising to 6.63 and 10.4 mg., the acetoacetic acid and acetone value remaining about constant around 1 mg. This increase is confirmed by the increased output in the urine where there was a gradual increase for each hourly period coincident with the increased blood concentration. (In examining the table it should be noted that the first urine collection, at

4.00 p.m., was for a period of 2 hours, the bladder being emptied at 2.00, and no collection being made at 3.00.)

In connection with the results of these determinations, it is now interesting to note what happened to the plasma CO₂-combining powers for the same periods. Before anesthesia the figure obtained was 58.6; immediately after, it had fallen to 50.0; one hour after this, it had risen slightly to 52.8, and at the end of another hour it again had decreased to 50.0, coincident with an

TABLE II.

Determination of Acetone Bodies, CO₂-Combining Power, and Total Fat.

M. M., ♀, aged 27. Pericholecystic adhesions removed. Appendectomy.

Time.	Urine.			100 cc. of blood.				Remarks.
	Volume.	Acetoacetic acid and acetone (as acetone).	β -hydroxybutyric acid.	Acetoacetic acid and acetone (as acetone).	β -hydroxybutyric acid.	Total fat.	CO ₂ -combining power.	
	cc.	mg.	mg.	mg.	mg.	gm.	per cent	
2.00 p.m.		Negative.*		0.6	5.2	1.39	58.6	Bladder emptied. Ether anesthesia begun.
2.13 "								
3.00 "				0.6	3.55	1.51	50.0	Administration of ether ended.
4.00 "	57	1.37	2.87	1.2	2.84	1.47	52.8	
5.00 "	22	0.88	2.7	1.0	6.63	2.11	50.0	Slight hemolysis.
6.00 "	26	0.93	6.27	1.4	10.4	2.02	54.8	

* Ferric chloride and sodium nitroprusside tests.

Each of the postoperative blood specimens gave an odor of ether. Postoperative urines were withdrawn by catheter.

increase in β -acid from 2.84 mg. for the hour previous to 6.63 mg. It was thought, however, that this slight decrease was probably due to a slight hemolysis which was present in this specimen, but was not present in the others. The final determination is most significant, however, since there was a distinct increase in CO₂-combining power, beyond any possible limit of error, to 54.8 coincident with an increase in β -acid from 6.63 to 10.4 mg.

Figures in Table III are in harmony with those in Table II, though they are not quite so striking. Urine figures show the same gradual increase. (The 3.45 p.m. collection of 243 cc. was for $1\frac{3}{4}$ hours.) Unfortunately three of the blood acetone body determinations were accidentally spoiled. As a result of the anesthetic, the CO₂-combining power decreased from 55.1 to 46.2, coincident with an increase in the figures for acetoacetic acid and acetone from 0.48 to 1.0 mg., and for β -acid from 2.0 to

TABLE III.

Determination of Acetone Bodies, CO₂-Combining Power, and Total Fat.

M. P., ♂, aged 29. Posterior gastroenterostomy. Separation of adhesions. Appendectomy.

Time.	Urine.			100 cc. of blood.				Remarks.
	Volume.	Acetoacetic acid and acetone (as acetone).	β -hydroxybutyric acid.	Acetoacetic acid and acetone (as acetone).	β -hydroxybutyric acid.	Total fat.	CO ₂ -combining power.	
	cc.	mg.	mg.	mg.	mg.	gm.	per cent	
2.00 p.m.		Negative.*		0.48	2.0	0.653	55.1	Bladder emptied. Ether anesthesia begun. Administration of ether ended.
3.17 "								
3.45 "	243	0.0	9.77	1.0	4.64	0.629	46.2	
5.45 "	40	1.14	9.25		7.04	0.707	51.0	
7.45 "	33	2.18	6.64	0.6	6.04	0.725	51.0	
9.45 "	50	2.84	11.0			0.666	50.8	

* Ferric chloride and sodium nitroprusside tests.

Postoperative urines were withdrawn by catheter.

4.64 mg. The most significant feature, however, is the increase in CO₂-combining power from 46.2 to 51.0 during the next period of 2 hours coincident with an increase in β -acid from 4.64 to 7.04 mg.

Blood fat determinations were carried out in the last two cases because it was thought that, since traces of fat may escape through the filter during the removal of the proteins and appear in the filtrate, this might account in part for the increased value obtained

following ether anesthesia. Very probably this is true, and many figures in Table I are undoubtedly higher than they should be, for the reason that the blood withdrawn immediately after anesthesia contained relatively large amounts of ether. This could not be aerated off before precipitation of the blood proteins or before boiling the filtrate with the reagents because of the probability of volatilizing the preformed acetone at the same time (8). The β -acid values expressed in Tables II and III, however, show definite, true increases in this substance, because the fat values remained constant while the β -acid values increased; the ether was becoming less concentrated in the later specimens; and, most important, corresponding increases in excretion were found in the urine. It would appear, therefore, from the results as a whole, that the blood acetone bodies could have had little to do with the decreased plasma bicarbonate after ether anesthesia. This decrease was undoubtedly due to other factors (9).

EXPERIMENTAL.

Interfering Substances.

1. *Ether*.—Ether was boiled with the reagents to determine whether or not a precipitate was formed from it. A precipitate formed only after the addition of 5 cc. of 5 per cent dichromate, the fluid becoming green in color. It was observed in this experiment that some ether was being lost through the reflux condenser.

2. *Fat*.—(A) Neutral olive oil was boiled with the reagents in usual concentration to determine whether or not this would give a precipitate, with the result that a precipitate formed in considerable quantity after dichromate was added. This was freed from excess fat by extraction with alcohol and ether.

(B) 60 mg. of neutral olive oil were thoroughly mixed with a 10 cc. portion of a blood specimen. A determination for total acetone bodies was then carried out on this specimen with the result that, when calculated per 100 cc. of blood, a value of 6.6 mg. was obtained. At the same time a solution of 60 mg. of olive oil in a little ether (about 1 or 2 cc.) was thoroughly mixed with another 10 cc. portion of the same blood. A determination for total acetone bodies was then carried out with the result that 15.8 mg. (as acetone) were obtained (calculated per 100 cc. of blood).

(C) 10 cc. of a blood specimen were analyzed for total acetone bodies in the usual manner. The result was 0.59 mg. as acetone per 100 cc. of blood. To another 10 cc. portion of the same blood specimen 60 mg. of olive oil (about equal to the normal fat content of 10 cc. of blood) were added, and an analysis was made as with the first portion. 0.51 mg. per 100 cc. of blood was obtained. To a third portion of the same blood specimen were added 60 mg. of olive oil in solution in a small amount of ether, and the whole was thoroughly mixed. An analysis was then made for total acetone bodies, the filtrate first being boiled with the H_2SO_4 and $HgSO_4$ reagents, but without dichromate for 30 minutes, to precipitate the preformed acetone. The hot liquid was then aerated for 10 minutes to remove the ether; 5 cc. of 5 per cent dichromate were added after boiling had commenced, and after boiling had continued for $1\frac{1}{2}$ hours longer the determination was completed. The result was 7.42 mg., as acetone, calculated per 100 cc. of blood, over twelve times the result obtained from analysis of the blood alone.

3. *Removal versus Non-Removal of Ether from Blood Filtrate.*—Total acetone bodies were determined on a specimen of blood, withdrawn immediately after ether anesthesia, having a strong odor of ether. The ether was removed by aeration after the first 30 minutes of boiling, as previously described. The result was 9.4 mg., as acetone, per 100 cc. of blood. A simultaneous determination of total acetone bodies was made on the same blood, no attempt being made to remove the ether. 10.0 mg., as acetone, per 100 cc. of blood were obtained.

4. *Glycerol.*—A few drops of glycerol, weighing exactly 129 mg., were placed in a 500 cc. Erlenmeyer flask with 25 cc. of water. Procedure was then carried out as for total acetone bodies. Upon the addition of the dichromate this was immediately reduced giving a green color. A precipitate of 462.2 mg. was formed which was only slightly soluble in HCl and gave a positive Lieben's, but a negative Gunning's, iodoform test.

5. *Oleic Acid.*—Oleic acid was treated in the same manner as the glycerol, 115.6 mg. forming 12.4 mg. of precipitate with the reagents.

Tests of the reagents showed that these alone formed no precipitate. No blank determinations were made on any of the blood or urine filtrates.

SUMMARY.

Observations of the acetoacetic acid and acetone (expressed as acetone) and the β -hydroxybutyric acid of the blood were made before and after ether anesthesia on twelve patients by the method of Van Slyke and Fitz, and the CO_2 -combining powers before and after anesthesia on eight of these patients by the Van Slyke method. A series of blood and urine specimens from each of two of these patients was also withdrawn over a number of hours following ether anesthesia, the blood, in addition to the above mentioned determinations, being examined for total fats by Bloor's method, and the urine for acetoacetic acid and acetone (as acetone) and β -hydroxybutyric acid by Van Slyke's method. A number of experiments were carried out to determine sources of error in analyzing blood containing ether. Removal of ether from blood filtrates was accomplished by aeration of the mixed filtrate and reagents after 30 minutes boiling to precipitate the preformed acetone and acetoacetic acid.

Contrary to the results of Reimann and Bloom, it was found that the blood concentration of acetone bodies was but little affected during the period of anesthesia, which was, on the average, a period of 48 minutes. It was found in the two cases examined over a longer period that there was an increase in these substances a few hours later, a finding which was confirmed by their increased output in the urine. The CO_2 -combining powers, however, increased even during increase of β -hydroxybutyric acid.

The results obtained for acetone bodies on bloods taken previous to anesthesia were, on the average, lower than those reported by Reimann and Bloom, the majority agreeing with the figures given by Van Slyke and Fitz, and also by Marriott, for normal blood. It is possible that Reimann and Bloom's high results find explanation in occasional failure to filter off their precipitate soon after the period of boiling was finished. Van Slyke and Fitz (10) have, since the appearance of Reimann and Bloom's paper, pointed out that this precaution is necessary.

Experimental data indicate that fat in the presence of ether and ether itself may interfere with the accuracy of the method, since both may form a precipitate with the reagents. It could not be shown from analyses on postoperative bloods that ether

directly effected much error, but through its ability to penetrate the filter it apparently carried with it some fat in solution causing an increase in precipitate. Glycerol formed a comparatively large precipitate with the reagents, oleic acid a much smaller precipitate.

CONCLUSIONS.

Acetone bodies were not formed promptly enough during ether anesthesia in the cases reported to account for the decreased plasma bicarbonate.

Analyses reported for β -hydroxybutyric acid on postoperative bloods may in some instances have been too high due to an error introduced as a result of the ether content.

The author wishes to thank Professor Ludwig Kast, of the Department of Medicine, for permission to engage in, and approval of, this work; Professor Victor C. Myers, of the Department of Laboratories, for helpful advice and suggestions; and Doctor C. H. Whiting, of the Department of Surgery, for his kind cooperation and assistance in attending to the collections of blood and urine specimens.

BIBLIOGRAPHY.

1. Reimann, S. P., and Bloom, G. H., *J. Biol. Chem.*, 1918, xxxvi, 211.
2. Van Slyke, D. D., and Fitz., R., *J. Biol. Chem.*, 1917, xxxii, 495.
3. Van Slyke, D. D., *J. Biol. Chem.*, 1917, xxxii, 455.
4. Van Slyke, D. D., *J. Biol. Chem.*, 1917, xxx, 347.
5. Marriott, W. M., *J. Biol. Chem.*, 1914, xviii, 507.
6. Bloor, W. R., *J. Biol. Chem.*, 1914, xix, 1.
7. Bloor, W. R., *J. Biol. Chem.*, 1914, xvii, 377.
8. Folin, O., *J. Biol. Chem.*, 1907, iii, 177.
9. Henderson, Y., and Haggard, H. W., *J. Biol. Chem.*, 1918, xxxiii, 345.
10. Van Slyke, D. D., and Fitz, R., *J. Biol. Chem.*, 1919, xxxix, 23.

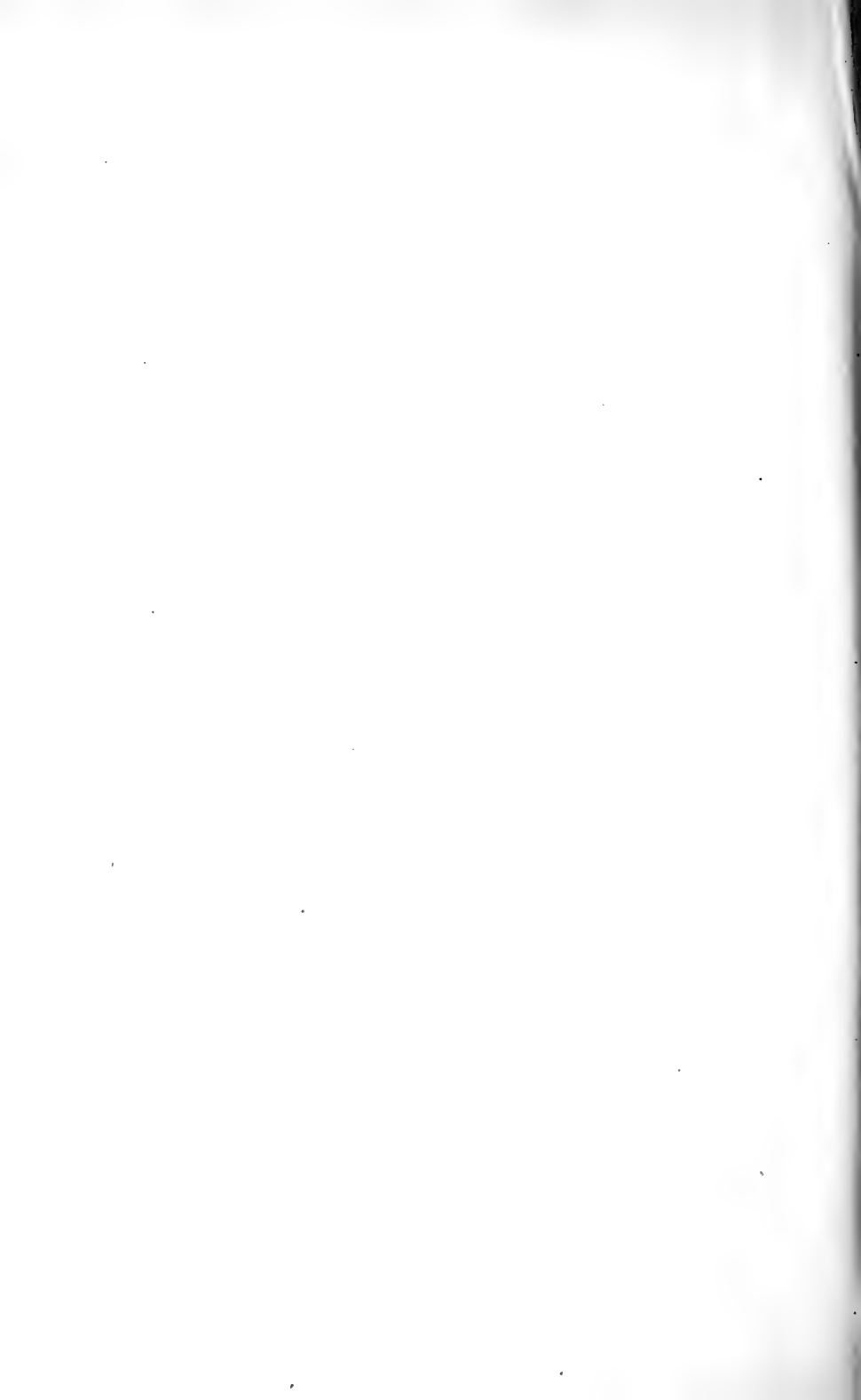

MILK AS A SOURCE OF WATER-SOLUBLE VITAMINE. II.*

BY THOMAS B. OSBORNE AND LAFAYETTE B. MENDEL.

WITH THE COOPERATION OF ALFRED J. WAKEMAN.

(From the Laboratory of the Connecticut Agricultural Experiment Station
and the Sheffield Laboratory of Physiological Chemistry,
Yale University, New Haven.)

(Received for publication, February 26, 1920.)

Early in the course of our nutrition experiments upon rats¹ we learned that both milk—dried milk powder was used—and what we termed “protein-free milk” prepared from it furnished something without which the animals could not grow satisfactorily when they were kept on “synthetic” diets consisting of mixtures of more or less purified isolated food substances. Subsequently Hopkins² published striking experiments showing that fresh milk, used in quantities surprisingly small when compared to the amounts which we had incorporated into our successful rat diets, also was effective in securing growth on the so called synthetic food mixtures consisting of purified proteins, fat, carbohydrates, and salts. Experience had shown us the necessity of incorporating as much as 28 per cent of our protein-free milk into our food mixture in order to secure adequate growth. The actual milk solids furnished by some of the quantities of fresh milk which Hopkins used effectively amounted “to no more than from 1 to 3 or 4% of the whole food eaten.” The calorific value of Hopkins’ foods was comparable with that fed by us.

Since these pioneer experiments our knowledge of the significance of those nutrition-promoting substances now commonly

* The expenses of this investigation were shared by the Connecticut Agricultural Experiment Station and the Carnegie Institution of Washington, Washington, D. C.

¹ Osborne, T. B., and Mendel, L. B., *Carnegie Institution of Washington, Publication No. 156*, pt. ii, 1911.

² Hopkins, F. G., *J. Physiol.*, 1912, xliv, 425.

designated as vitamines has been largely augmented. Bearing this in mind we undertook further investigations in the hope of explaining the apparent discrepancies between our earlier results and those of Hopkins as to the minimal amount of milk needed to supply an adequate quota of the water-soluble vitamine. The entire subject has already been reviewed in some detail by us.³

Attempting to duplicate the results of Hopkins we fed diets consisting of casein or edestin, starch, a salt mixture, lard, and butter fat along with fresh milk offered in varying quantities. In contradiction to some of Hopkins' results we found, under the conditions of our investigation, that 2 cc. of milk per day rarely sufficed to enable rats, on the diets mentioned, to make more than very slight gains in weight. Many of the animals were barely maintained when such small quantities furnished the sole source of water-soluble vitamine. Not until at least 16 cc. of fresh milk per day were supplied along with the food mixture was anything approaching a normal rate of growth secured. Even this amount sometimes failed.

The large quantity of fresh milk thus indicated as necessary to supply water-soluble vitamine is equivalent, broadly speaking, to the quantities of protein-free milk which were found necessary, in our earlier experiments, to secure adequate growth with the synthetic dietaries, even when due attention was paid to the calorific make-up of the food, the quality and content of its protein, and the supply of fat-soluble vitamine. As was pointed out in the previous report of our investigation we tested the possibility that pasteurization of milk, as it is conducted preliminary to the distribution of most city milk supplies, might affect the vitamine content of the milk employed by us. The use of unpasteurized milk of known origin did not improve our results; the smaller quantities—less than 16 cc.—still proved inadequate to promote growth at a maximum rate.

To another aspect of this question we have referred as follows:³

“That the deficiency of diets containing the lesser amounts of milk involves the vitamine factor is rendered more than probable by the fact that these comparatively small additions of yeast, the highly efficient growth-promoting power of which we have discussed elsewhere, sufficed

³ Osborne, T. B., and Mendel, L. B., *J. Biol. Chem.*, 1918, xxxiv, 537.

to render the previously inadequate ration satisfactory for growth. As a rule the most significant outcome of the yeast additions (which were fed apart from the rest of the food and therefore could not have altered its flavor) was a larger food intake."

Our earlier investigations with fresh milk were carried out during the winter season when the cows in this region are deprived of green pasture and are stall-fed. It seemed not impossible, therefore, that the relatively large quantity of milk necessitated as a source of water-soluble vitamins in those experiments might be associated with quality of milk inferior from the vitamin standpoint, owing to the winter diet of the cows. Other investigators have of late intimated that the content of the milk in various nutrition-promoting factors may be markedly altered by the character of the diet from which the various vitamins are assumed to be derived. Our own investigations have taught us that the grasses and other green foods, which cattle are likely to obtain in greater abundance during the summer season, are rich in vitamins.⁴

Consequently we have undertaken a further series of experiments on rats which were supplied with a diet presumably adequate in every respect except for the absence of the water-soluble vitamins.⁵ The food mixtures consisted of:

	<i>per cent</i>
Casein.....	18
Salt mixture*.....	4
Starch.....	49
Butter fat.....	9
Lard.....	20

* The composition of the salt mixture used is given in Osborne, T. B., and Mendel, L. B., *J. Biol. Chem.*, 1919, xxxvii, 557.

In addition to this mixture, which was fed *ad libitum*, the rats received daily, in measured portions in a separate container,

⁴ Osborne, T. B., and Mendel, L. B., *J. Biol. Chem.*, 1919, xxxvii, 187; xxxix, 29.

⁵ In numerous experiments with such a food mixture we have demonstrated that the addition of 0.2 gm. of dried brewery yeast fed apart from the ration suffices to induce the animals to eat sufficient food and promote growth, whereas without the yeast addendum their food intake gradually declines and they die within a period of 40 to 80 days (Osborne, T. B., Wakeman, A. J., and Ferry, E. L., *J. Biol. Chem.*, 1919, xxxix, 35).

varying quantities of unpasteurized milk obtained fresh from cows known to be feeding in open pasture. Until within the last month of our experiments the five cows were kept all day in the pasture. During the last month, owing to the lateness of the season, the available pasturage was small. Night and morning the cows were fed with rations of corn gluten and wheat bran together with hay and corn stalks. This method of feeding is the one usually employed in this region where milch cows are pastured during the summer.

The outcome has been comparable with the experiments earlier published, as the appended charts show. Thus with additions of 2 cc. of summer milk (Rats 5904, 5911, 5891, Chart I), fed during a period of 37 or more days, no permanent gains were secured. Additions of 5 cc. (see also Rats 5944, 5943, 5947, Chart II) invariably produced better, though by no means adequate, growth; nor was the latter usually obtained with daily additions of 10 cc. of summer milk. Whenever the vitamine supplement in the form of milk was still further increased, improvement in the rate of growth occurred. Of course, the rats ate more in these cases. The weekly food intakes, not including that furnished by the milk solids, are shown in the charts.

The inferiority of even 15 cc. of the fresh, unpasteurized summer milk as a source of water-soluble vitamine, in contrast with 0.2 gm. of dried brewery yeast, is indicated by the more rapid gains made by all the animals thus tested when the yeast addendum replaced the milk. In our previous report we have indicated that this is not due to the large volume of fluid intake, represented by 15 cc. of milk, preventing the ingestion of a sufficient amount of the basal diet; for in the experiments there recorded, when yeast was furnished in addition to both the large volume of milk and the basal diet, increased intakes of food with additional gains in weight followed.

When the experiments were *started* with 10 cc. of the summer milk, there was no greater advantage (see Chart III, Rats 6096, 6097, 6101); and even 15 cc. of milk fed from the start (Rats 6093, 6098, 6092, Chart III) barely sufficed as a source of water-soluble vitamine to promote growth at a normal rate. Here again an inspection of the charts shows the superiority of 0.2 gm. of dried yeast, in contrast with the large volumes of milk.

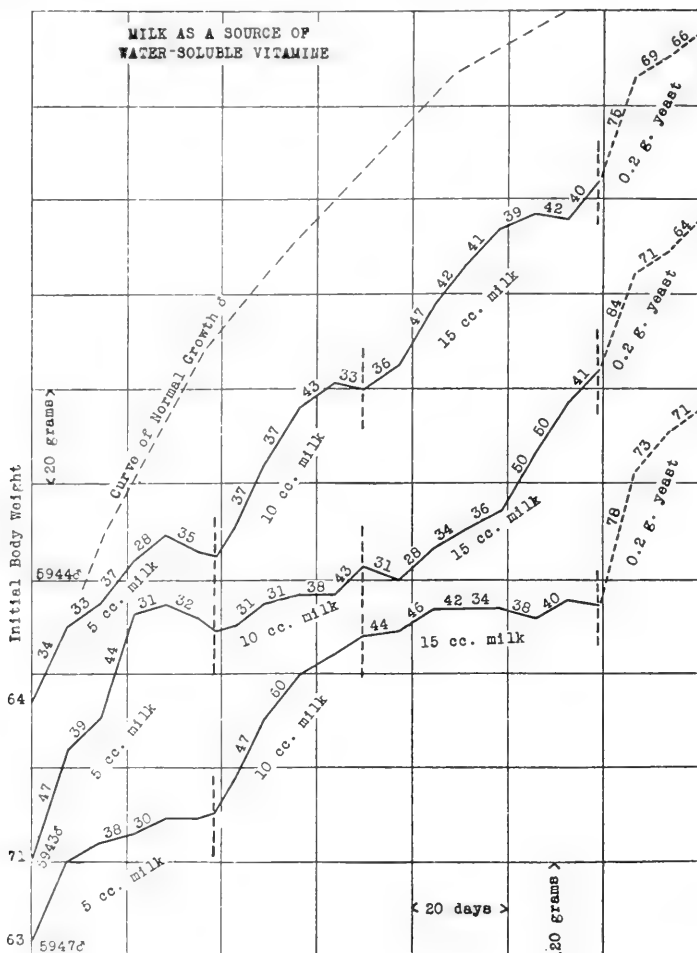

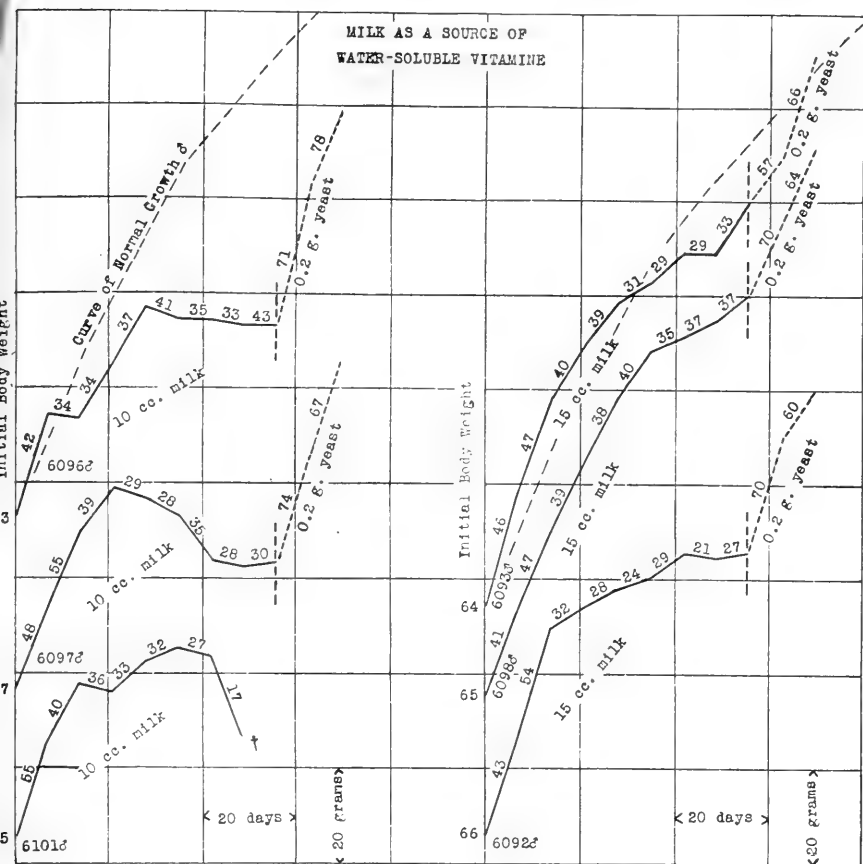

CHART III. Showing the failure of 10 cc. of fresh unpasteurized summer cow's milk (Rats 6096, 6097, 6101), fed apart from and in addition to a ration adequate except in respect to the lack of water-soluble vitamine, to promote growth at a normal rate. The weekly food intakes, expressed in gm. (exclusive of the milk solids), are indicated, where available, on the curve of growth. The prompt increase in food intake and growth response (shown by the interrupted line) when milk was replaced by small daily doses of brewers' yeast indicate that the previous failures were associated with the lack of water-soluble vitamine.

When 15 cc. of the same milk (Rats 6093, 6098, 6092) supplied the water-soluble vitamine better growth responses were obtained; but not so good as those secured by the feeding of 0.2 gm. of dried yeast.

In the original experiments of Hopkins the food was reported to have the following composition:²

	Pure casein mixture. <i>per cent</i>	"Protene" mixture. <i>per cent</i>
Protein.....	22.0	21.3
Starch.....	42.0	42.0
Cane Sugar.....	21.0	21.0
Lard.....	12.4	12.4
Salts*.....	2.6	3.3

* "The salts added were obtained by incinerating the normal laboratory food on which the rats had been kept when not under experiment, and consisted of equal parts of the ash of oats and dog-biscuits."

It was, of course, possible that the ash of oats and dog biscuits there used might contain some unsuspected inorganic ingredients which would account for the remarkable gains claimed by Hopkins for some of the animals to which the small quantities of milk were supplied. We therefore imitated the diets used by him as closely as the preparation of ash from a product of such uncertain composition as dog bread would permit. These food mixtures consisted of:

	<i>per cent</i>
Casein.....	18.0
Salts*.....	4.5
Starch.....	50.5
Butter fat.....	9.0
Lard.....	18.0

* The salts consisted of equal parts of the ash of dog bread and the ash of whole oats.

The outcome was in harmony with all our experience in showing that even additions of 10 cc. of fresh milk per day were insufficient to effect a food intake adequate for growth at a normal rate. Chart IV, showing the results in graphic form, also includes the growth curves of rats fed on diets containing our own often described salt mixture. The milk in the two series was obtained from the same source, so that the experiments are strictly comparable. The outcomes are not essentially different.

Recent studies of the antiscorbutic value of cow's milk⁶ have indicated that on this score it must be classed as less valuable than many of the raw fruits and vegetables. Whereas quantities of the latter—less than 10 gm. daily—will prevent scurvy in guinea pigs upon a diet otherwise devoid of antiscorbutic material, 100 to 150 cc. daily of raw cow's milk are required for this species, according to Barnes and Hume; while monkeys require larger quantities. Similarly, relatively large

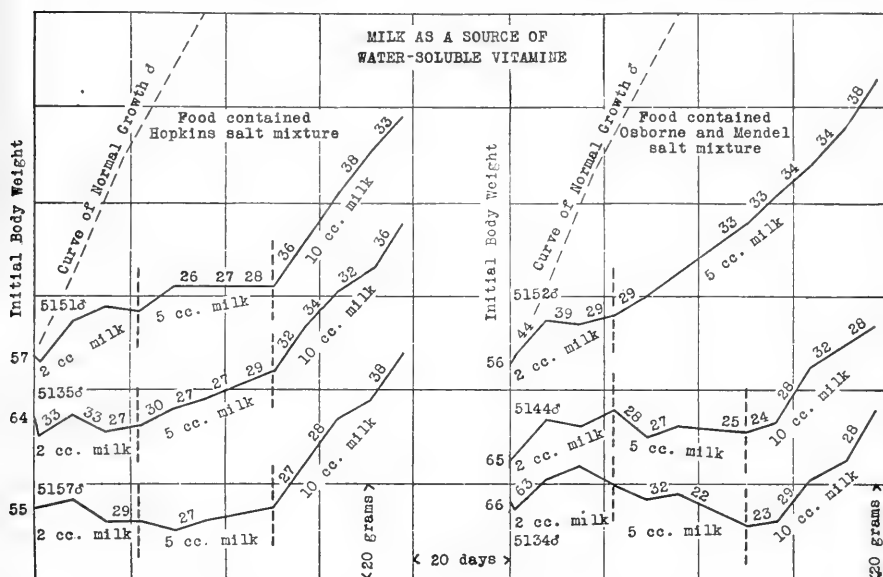
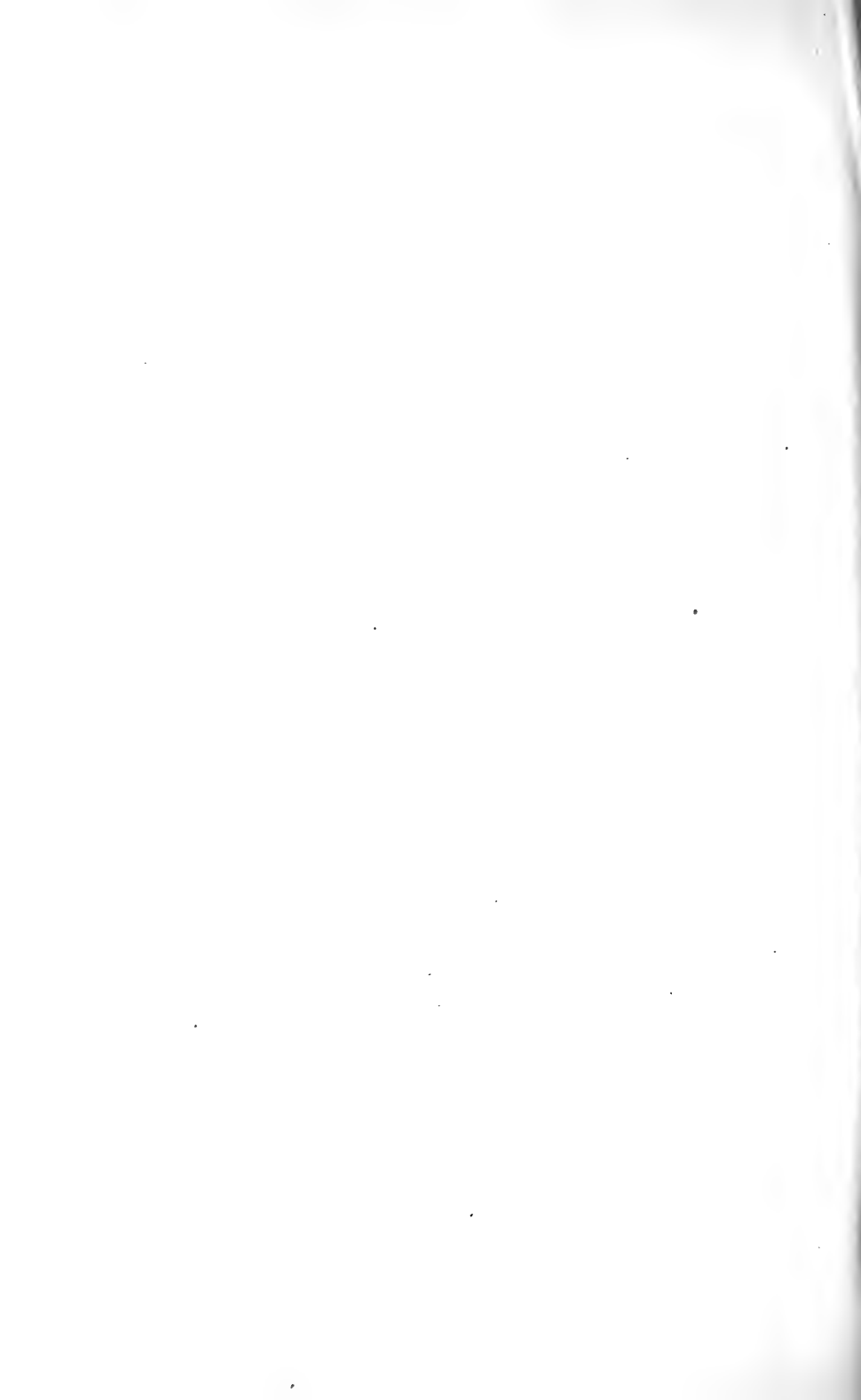

CHART IV. Showing that rats grow at approximately the same rate whether they receive a salt mixture similar to that used by Hopkins or the salt mixture used by ourselves, when like quantities of milk supply all the water-soluble vitamine. The weekly food intakes, expressed in gm. (exclusive of the milk solids), are indicated, where available, on the curve of growth.

quantities of milk are required to produce the increased intake of food and improved rate of growth, which are readily secured by very small quantities of many (dried) green vegetables. The consequences of this relative poverty of milk in water-soluble vitamine for the artificial feeding of infants have already been referred to by us.

⁶ Cohen, B., and Mendel, L. B., *J. Biol. Chem.*, 1918, xxxv, 425. Chick, H., Hume, E. M., and Skelton, R. F., *Biochem. J.*, 1918, xii, 131; *Lancet*, 1918, i, 1. Barnes, R. E., and Hume, E. M., *Lancet*, 1919, ii, 323.



THE EFFECT OF INTRAVENOUS INJECTIONS OF ACTIVE DEPOSIT OF RADIUM ON METABOLISM IN THE DOG.

BY RUTH C. THEIS AND HALSEY J. BAGG.

(From the Huntington Fund for Cancer Research, Memorial Hospital, and the Mrs. W. A. Clark Fund, Harriman Research Laboratory, the Roosevelt Hospital, New York.)

(Received for publication, February 10, 1920.)

There have been few experiments reported on the effect of radium on normal metabolism. Berg and Welker (1) have studied the effect of radium salts upon the metabolism of dogs. The doses employed were very small, but these investigators concluded that ingestion of radium *per os* was followed by a stimulation of the catabolic processes as indicated by a slightly increased output of nitrogen in the urine. An increased volume of urine was also noted.

In experiments where radium salt is given, it is obvious that one cannot be certain whether the effects noted are due to the element radium or the rays emitted by the element.

The present work has been planned to study the effect of the active rays upon the general metabolism of the dog. Solutions of sodium chloride which contained active deposit from radium emanation were used. To prepare the solutions, sodium chloride is first dried and packed into a bulb and left in contact with radium emanation for 3 or 4 hours.¹ The emanation is then pumped off and the salt dissolved in water in such concentration as to give a solution isotonic with the blood. The solution is drawn into a syringe and the amount of activity determined by a γ -ray instrument. After the injection, the radioactivity remaining in the syringe is again determined and the amount injected computed by difference. The radioactivity is expressed in millicuries. It should be noted that the number of millicuries

¹ The preparation of the radioactive sodium chloride was first called to our attention by Dr. William Duane, of Harvard University.

injected cannot be controlled exactly as an irregular quantity (25 to 50 per cent) will remain in the syringe. The rapid decay of the active deposit introduces a second source of error in estimating the quantity injected. Radium A decays completely within 15 minutes after the preparation of the solutions. Since our injections were made after 15 minutes, only Radium C need be taken into account. Radium C falls to 3 per cent of its initial value within 3 hours, so that the physiological activity of the injected solution can last only a relatively short time. The physiological effects are presumably due to the α -radiation.

EXPERIMENTAL.

Two animals were employed in the experiments described below. Dog 1 was a Dalmatian female of about 15 kilos. Benedict (2) has shown that this breed of dog regularly excretes large amounts of uric acid. We therefore used a Dalmatian in order to bring out any possible effect of the emanation upon the metabolism of this substance. Dog 2 was a bull-terrier female of about 12 kilos. Each animal was kept in a metal metabolism cage constructed for the proper separation and collection of urine and feces.

The diets employed for both dogs were made up of cracker meal, dog biscuit, evaporated milk, bone ash, and (in the case of Dog 2) a little casein. Dog 1 received 6 gm. of nitrogen and about 1,000 calories per day; Dog 2 received 5 gm. of nitrogen and about 660 calories per day.

The animals were catheterized daily just before feeding, and the bladder was washed out with distilled water followed by a little boric acid. The urine was collected under toluene and usually analyzed on the same day. The rectal temperature was taken and blood counts were made at frequent intervals. The injections were made into one of the superficial veins of the ear.

All analyses were made in duplicate; nitrogen was determined by the Kjeldahl-Gunning method, urea by a macro-urease method, ammonia by the older macro method of Folin. Creatinine was determined by the colorimeter method of Folin, uric acid by the Benedict-Hitchcock modification of the Folin-Déniš method, and phosphates were determined by titration with uranium acetate. Albumin, sugar, and creatine were tested for frequently with negative results.

Experiment 1.

Table I records the experiments with the Dalmatian dog. The first 6 days (February 28 to March 5) serve as the control period before the first injection. On March 5 the dog received an intra-

venous injection of 95 millicuries of the active deposit. On the day of the injection there seemed to be no effects on the general condition of the animal but on the 2 following days the dog had to be coaxed to eat the food and the feces were softer than usual. After this no further general effects were present. An examination of the nitrogen partition shows a sharp rise in the total nitrogen output, which reaches its maximum on the 2nd day after the injection. This increased nitrogen is distributed among all the nitrogen constituents except creatinine. Ammonia increases proportionately more than does urea. Indeed the increase in the ammonia suggests a definite acidosis. The uric acid increases by about 50 per cent over that of the preliminary period. It is possible that this is associated with the destruction of white blood corpuscles which follows the injection. Phosphates and urinary volume both tend to show definite increases over the preliminary period.

The total nitrogen remains high for 5 days after the injection, and then drops suddenly. The ammonia and particularly the uric acid drop more slowly. The latter does not reach the level of the preliminary period until 12 days after the injection.

On April 4 the dog received a second intravenous injection of 30 millicuries of the active deposit. This dose is scarcely a third of the quantity given in the preceding experiment. The total nitrogen again increases, and again the maximal figure is reached on the 2nd day after the injection. The small dose employed in this experiment is followed by only a slight and transitory rise in uric acid. On the 3rd and 4th days after the injection creatinine shows an increase well above the preliminary period.

On April 15 the dog received its third injection of the active deposit. On this day 42 millicuries were given. This injection is followed by a marked and prolonged effect. Total nitrogen, urea, and ammonia increase and remain high for almost 2 weeks. Creatinine and uric acid both show a marked increase. The high figures for those constituents continue for about 8 days after the injection. Throughout the series of treatments on Dog 1, we find a steady increase in the volume of urine eliminated. At first the amount was 200 cc. and after the treatments it gradually rose to 1 liter.

Mar.	16	15.00	450	1.018	4.65	3.99	85.90	0.213	4.59	0.094	2.02	0.114	2.45	0.759			
"	31		295	1.020	4.24	3.58	84.38	0.255	6.02	0.094	2.22	0.098	2.31	0.790	84		
Apr.	1		410	1.023	4.59	3.91	85.12	0.247	5.38	0.097	2.13	0.109	2.38	0.873	100		
"	2	15.11	345	1.021	4.86	4.17	85.76	0.218	4.49	0.100	2.06	0.102	2.10	0.811	76		
"	3		410	1.016	4.66	4.02	86.50	0.235	5.06	0.098	2.11	0.095	2.05	0.852	104		
"	4		395	1.016	4.86	4.16	85.75	0.216	4.45	0.101	2.08	0.111	2.30	0.811	80	101.2	
"	5		508	1.015	4.89	4.23	86.68	0.202	4.13	0.099	2.03	0.107	2.20	0.873	84		
"	6		430	1.019	5.04	4.19	83.20	0.261	5.18	0.118	2.34	0.101	2.00	0.998	92	99.8	
"	7		325	1.018	4.77	3.99	83.53	0.196	4.11	0.121	2.54	0.101	2.13	0.831	76		
																Red cells 4,136,000	
																White " 10,200	
																Hemoglobin 80%	
"	8		518	1.014	4.66	4.02	86.30	0.215	4.62	0.103	2.22	0.095	2.04	0.915	96	99.4	
"	9	15.30	519	1.016	5.18	4.33	83.64	0.215	4.16	0.120	2.31	0.100	1.95	0.831	52	99.3	
"	10		500	1.014	4.72	3.88	82.34	0.252	5.35	0.122	2.60	0.099	2.10	0.894	100		
"	11	15.30	490	1.014	4.97	4.13	83.08	0.252	5.08	0.125	2.52	0.106	2.13	0.831	80	100.4	
"	12		382	1.016	4.63	3.93	84.90	0.235	5.09	0.124	2.68	0.113	2.44	0.790	80		
"	13-14	15.5	670	1.020	4.74	4.09	86.20	0.202	4.26	0.124	2.61	0.109	2.31	0.831	80	100.6	
																Red cells 4,690,000	
																White " 7,600	
																Hemoglobin 80%	
III†	"	15	465	1.015	4.52	3.75	82.86	0.241	5.34	0.126	2.80	0.113	2.51	0.749	88		
"	"	16	550	1.017	5.24	4.40	83.99	0.207	3.96	0.152	2.90	0.164	3.14	0.852	72	101.0	
																Red cells 4,890,000	
																White " 6,150	
																Hemoglobin 80%	
"	"	17	15.2		5.46	4.64	84.61	0.311	5.54	0.169	3.08	0.174	3.17	1.020	96	100.3	
"	"	18	15.4	535	1.015	5.17	4.30	83.14	0.280	5.43	0.160	3.10	0.172	3.33	0.831	80	101.0
																Red cells 4,890,000	
																White " 6,150	
																Hemoglobin 80%	

* Injected 95 millicuries of active deposit at 1.00 p.m.

† " 30 " " 2.40 "

‡ " 42 " " 6.30 "

TABLE I—Continued.

Period.	Date.	Weight of dof.	Urine.												Titrate- able 0.1 N acid.	Tempera- ture. °F.	Remarks.	
			Specific gravity.		Total N.		Urea N.		Ammonia N.		Creatinine N.		Uric acid N.					P ₂ O ₅
			gm.	per cent	gm.	per cent	gm.	per cent	gm.	per cent	gm.	per cent	gm.	per cent				
	1919	cc.																
	Apr. 19	15.2	678	1.012	5.05	4.24	83.89	0.252	5.00	0.159	2.97	0.161	3.19	0.811	60	100.8		
	"	20	570	1.010	4.91	4.13	84.13	0.275	5.60	0.150	3.06	0.151	3.08	0.811	60	101.1		
	"	21	750	1.012	5.40	4.63	85.67	0.255	4.72	0.155	2.87	0.129	2.39	0.790	64	100.7		
	"	22	640	1.011	4.85	4.17	85.93	0.287	5.92	0.151	3.04	0.133	2.76	0.790	61	100.7		
	"	23	670	1.013	5.39	4.58	84.90	0.224	4.16	0.144	2.68	0.124	2.30	0.852	61			
	"	28	485	1.017	5.42	4.55	83.99	0.264	4.87	0.120	2.22	0.104	1.93	0.790	96	100.6		
	"	29	600	1.011	5.19	4.48	86.18	0.255	4.92	0.103	1.99	0.104	2.00	0.811	60			
	"	30	848	1.009	5.08	4.39	86.36	0.230	4.53	0.101	1.99	0.111	2.19	0.706	64			
	May	1	848	1.011	5.42	4.66	85.93	0.233	4.29	0.108	2.00	0.112	2.08	0.786	75	99.3		
	"	2	830	1.010	5.67	4.87	86.95	0.207	3.66	0.109	1.93	0.106	1.87	0.748	72	100.4		
	"	3	850	1.008	4.98	4.26	85.50	0.238	4.90	0.112	2.32	0.127	2.55	0.764	67	100.0		
	"	7	1,004	1.009	4.91	4.22	85.87	0.198	4.04	0.117	2.39	0.125	2.55	0.786	73	100.5		
IV§	"	8	1,005	1.010	4.86	4.23	86.98	0.188	3.87	0.114	2.36	0.127	2.61	0.786	63	100.4		

§ Injected 64.5 millieuries of active deposit at 1.19 p.m.

On May 8 the animal received a fourth injection of 64 millicuries. This was followed by vomiting and refusal of most of the food for several days. The fact that the third and fourth injections were smaller in quantity than the first, and were followed by marked general effects, shows that the animal failed to recover completely from previous treatments with the emanation. Shortly after the fourth injection the animal was killed and an autopsy made. The autopsy findings will be reported in detail elsewhere.

Experiment 2.

Table II gives the results of injections of active deposit on the bull terrier; uric acid is eliminated only in very minute quantities, hence quantitative determinations of this constituent have been omitted. After a control period of 5 days, Dog 2 received the first injection of 120 millicuries. Urine voided voluntarily 15 minutes after the injection contained 9 millicuries of radioactivity. A decided rise in total nitrogen was noted which reached the maximum figure on the 2nd day. Urea rose proportionately with the total nitrogen and ammonia was decidedly increased. Total phosphates were almost doubled. White cells dropped from about 14,000 to 2,000 after the injection. The bull-terrier did not seem to bear the injections so well as the preceding animal for on the 3rd day following this treatment there was vomiting, diarrhea, and refusal of food. Determinations were omitted during this period. This dog also tended to lose weight throughout the experiment. 1 kilo was lost during this period so that creatinine which was high in the control period was considerably lower when the second injection of 17 millicuries was given.

Probably because of the decided effect produced by the first treatment 3 weeks previously, this small dose caused an appreciable rise in total nitrogen with a proportional increase in urea, ammonia, and creatinine, which was evident for 3 days. Total phosphates were somewhat increased.

10 days after the second treatment 54 millicuries were injected. This dose produced no general effect except that the animal refused part of the food on the 4th day. Total nitrogen, urea, and ammonia were considerably increased for 3 days and remained above normal for 10 days. Creatinine was not affected.

TABLE II.

Period.	Date.	Weight of dog.	Urine.										Titratable Phosphoric acid.	Temperature.	Remarks.		
			Vol-ume.	Specific gravity.	Total N.	Urea N.		Ammonia N.		Creatinine N.		P ₂ O ₅					
		kg.	cc.		gm.	per cent	gm.	per cent	gm.	per cent	gm.	per cent	gm.	per cent	cc.	°F.	
Con-trol.	1919																
	June 4	12.6	168	1.028	3.73	3.22	86.18	0.132	3.53	0.177	4.73	0.624	60	101.5		Red cells 6,400,000	
	" 5		158	1.032	3.86	3.31	85.86	0.115	2.98	0.171	4.43	0.624	44	101.0		White " 13,800	
	" 6		288	1.018	3.78	3.28	86.52	0.179	4.74	0.177	4.67	0.707	61	101.0		Hemoglobin 85%	
	" 7		270	1.021	3.90	3.42	87.62	0.202	4.14	0.181	4.64	0.851	84	100.8		Red cells 5,924,000	
I*	" 8-9		610	1.019	3.60	3.08	85.47	0.165	4.61	0.177	4.91	0.852	81	101.7		White " 14,400	
	" 10	12.5	300	1.020	4.34	3.68	84.69	0.141	3.23	0.181	4.17	0.790	60	101.3		Hemoglobin 85%	
	" 11		280	1.025	4.52	3.79	83.85	0.224	4.96	0.175	3.87	1.31	96	100.6		White " 8,900	
	" 24		250	1.018	3.96	3.39	85.67	0.146	3.68	0.150	3.80	0.540	52	99.7		Hemoglobin 85%	
	" 25		180	1.022	3.76	3.24	86.18	0.157	4.17	0.158	4.21	0.416	40	100.6		Red cells 5,280,000	
III†	" 26		188	1.023	4.01	3.43	86.66	0.134	3.35	0.167	4.16	0.416	44	100.6		White " 4,550	
	" 27		250	1.020	4.21	3.70	87.77	0.137	3.26	0.162	3.88	0.457	44	100.1		Hemoglobin 80%	
	" 28	11.4	382	1.015	4.10	3.48	85.00	0.151	3.68	0.163	3.90	0.436	32	100.4		Red cells 4,976,000	
	" 29-30		538	1.020	4.04	3.44	85.22	0.166	4.37	0.161	4.00	0.540	44	100.6		White " 5,700	
	July 1		243	1.022	4.56	3.86	84.55	0.213	4.67	0.179	3.92	0.623	72	100.4		Hemoglobin 85%	
	" 2		248	1.020	4.22	3.60	85.21	0.204	4.85	0.177	4.19	0.603	56	100.6		Red cells 5,250,000	
	" 2																White " 4,450
																	Hemoglobin 85%

July 3	250	1.020	4.46	3.87	86.18	0.182	4.07	0.171	3.83	0.561	60	100.2
" 4	140	1.030	4.10	3.62	88.45	0.165	4.04	0.156	3.82	0.540	48	
" 5	150	1.025	4.14	3.64	88.50	0.174	4.20	0.158	3.82	0.499	64	
" 6-7	400	1.022	4.11	3.60	87.62	0.148	3.61	0.149	3.62	0.561	52	100.3
" 8	220	1.020	4.13	3.64	88.17	0.151	3.67	0.152	3.68	0.540	56	
" 9	155	1.028	4.14	3.63	87.62	0.162	3.93	0.158	3.82	0.519	56	
" 10	360	1.020	4.83	4.27	88.37	0.154	3.19	0.163	3.38	0.665	56	101.4
III†												
" 11	390	1.017	4.80	4.18	87.08	0.199	4.15	0.158	3.29	0.665	68	101.7
" 12	11.4	1.026	4.87	4.20	86.22	0.235	4.84	0.158	3.25	0.644	60	
" 13	205	1.025	4.43	3.92	88.43	0.148	3.35	0.162	3.64	0.561	52	
" 14	295	1.017	4.15	3.54	85.21	0.207	5.00	0.163	3.93	0.520	52	100.9
" 15	325	1.017	4.50	3.81	84.54	0.223	5.17	0.162	3.59	0.561	52	
" 16	385	1.016	4.43	3.77	84.90	0.219	4.94	0.156	3.53	0.541	60	
" 17	11.6	1.018	4.48	3.90	87.10	0.231	5.16	0.163	3.64	0.492	45	100.9
" 18	335	1.017	4.55	3.95	86.78	0.193	4.26	0.153	3.37	0.478	56	
" 19	328	1.017	4.66	3.97	85.16	0.185	3.98	0.155	3.32	0.499	52	101.3
" 20-21	550	1.018	4.13	3.52	85.37	0.168	4.08	0.152	3.68	0.478	40	100.8
IV§												
" 22	415	1.014	4.24	3.57	84.28	0.190	4.50	0.153	3.62	0.519	64	
" 23	11.4	1.017	4.42	3.76	85.10	0.224	5.08	0.152	3.43	0.561	68	
" 24	410	1.013	4.17	3.67	88.03	0.176	4.24	0.158	3.79	0.478	40	102.7
" 25	575	1.017	4.88	4.19	85.89	0.146	2.98	0.139	2.85	1.08	60	101.1

Red cells 5,800,000
White " 3,650
Hemoglobin 85%

Red cells 5,814,000
White " 4,100
Hemoglobin 80%

Red cells 5,200,000
White " 2,600
Hemoglobin 85%

* Injected 120 millieuries of active deposit at 7.15 p.m. on June 9.

† " 17.3 " " " 2.45 " " 30.

‡ " 54.7 " " " 4.45 "

§ " 146.4 " " " 3.00 "

|| No food eaten after this date.

2 weeks later, the last injection of 1.46 millicuries was given. All food was refused for 4 days, and when on the 5th day more food was eaten severe diarrhea immediately followed. The dog lost 1.5 kilos during this time. She was then anesthetized and an autopsy made.

DISCUSSION AND SUMMARY.

Our results record the effect of a purely physical agent, radium emanation, upon the metabolism. The experiment with Dog 1 is the most satisfactory, since in this animal the dosage employed was not great enough to produce general indisposition or sickness.

In every instance in both experiments the injection of active deposit was followed by an increased output of nitrogen, reaching the maximum figure on the 2nd day after the treatment. Urea fluctuates with the total nitrogen, but the absolute as well as relative amount of the total nitrogen excreted as ammonia nitrogen is decidedly increased, especially on the 2nd day after the treatment.

Much interest may be attached to the marked increase in creatinine which is noted in Dog 1. The quantity of this constituent is usually independent of volume and of total nitrogen. Shaffer (3) found some time ago that increased temperature had a tendency to increase creatinine but that it afterward went below normal. Van Hoogenhuyze and Verploegh (4) found an increase of 50 per cent in creatinine with no rise in total nitrogen in cases with a temperature. Leathes (5) found, on the other hand, that creatinine increased 20 per cent, but the total nitrogen increased 50 per cent in fevers. He concluded that the proportion of nitrogen excreted during fever appearing as uric acid was considerably increased but that as creatinine was consistently diminished. In our case the creatinine elimination does not fluctuate with temperature change—in fact the first increase in creatinine is noted after the second injection when the temperature has returned to normal. Uric acid at this time showed no increase. Although the highest creatinine values are noted on the days after the treatment when the nitrogen also is high, they do not increase proportionally to the total nitrogen. On the 2nd day of Period II nitrogen increased 3.5 per cent and creatinine 14 per

cent, and in Period III nitrogen increased 17 per cent while creatinine increased 28 per cent. On this day creatinine was 45 per cent higher than in the control period at the beginning of the experiment. The proportion of nitrogen as creatinine nitrogen was somewhat increased, but not greatly, after the treatment.

Uric acid showed a marked increase both absolutely and relatively following injection of radioactive deposit.

The effect of the injection seems to be cumulative because the third treatment in Dog 1, only a little larger than the second injection, produced a very marked effect, while the fourth treatment, although smaller than the first, produced nausea.

The writers wish to express their appreciation to the Radium Department for supplying the radium emanation and to Dr. Stanley R. Benedict for his suggestions during the work.

BIBLIOGRAPHY.

1. Berg, W. N., and Welker, W. H., *J. Biol. Chem.*, 1905-06, i, 371.
2. Benedict, S. R., *J. Lab. and Clin. Med.*, 1916-17, ii, 1.
3. Shaffer, P. A., *Am. J. Physiol.*, 1908, xxiii, 1.
4. van Hoogenhuyze, C. J. C., and Verploegh, H., *Z. physiol. Chem.*, 1908, lvii, 161.
5. Leathes, J. B., *J. Physiol.*, 1906-07, xxxv, 205.



THE DETERMINATION OF THE REFRACTIVITY OF HEMOGLOBIN IN SOLUTION.

BY FREDERICK H. HOWARD.

(From the Laboratory of Physiology, Williams College, Williamstown.)

(Received for publication, February 14, 1920.)

INTRODUCTION.

The refractivity of proteins in solution has been extensively investigated by Reiss, Herlitzka, Schmidt, and by Robertson and his collaborators. An excellent summary and discussion of these results, together with a bibliography, have been published by Robertson.¹ The following summary statement of facts recapitulates the main aspects of this work as far as they bear on the present problem.

(a) Proteins dissolved in water increase the refractive index of the solvent by an amount nearly proportional to the concentration of the protein. This approximately linear relation is expressed by the formula² $n - n_1 = a \times c$, where n represents the refractive index of the solution, n_1 the refractive index of the solvent, a a constant characteristic of the protein, and c the concentration of the protein. To determine the value of a for a given protein the refractive index of an aqueous solution of that protein in known concentration is first determined; from this value is subtracted the refractive index of the solvent, and the remainder is divided by the concentration; the quotient resulting is the value of a . If the value of a is known the percentage of that protein in a solution of unknown concentration can be calculated from the same formula.

¹ Robertson, T. B., *The physical chemistry of the proteins*, New York, 1918, 359.

² This formula does not express with entire precision the relation between n and c . It is based on the law of Gladstone and Dale which itself is only an approximation to experimental facts. It does, however, give the relation between n and c with a degree of inaccuracy not greater than the inherent error of refractometry under the conditions of this investigation.

(b) It has also been shown that the increase in refractive index produced by a protein is not sensibly affected by the presence of other substances in solution provided no considerable molecular change in the protein, or of its degree of hydration or dispersion, is produced. Therefore the concentration of a protein in solution with other proteins, or with acids, bases, or salts in low concentration, can be determined by observing the index of refraction of the solution with and without the protein in question.

(c) The value of a for a considerable number of proteins has been determined. These values range from 0.0023 to 0.0013.

(d) There are certain limitations to accuracy in refractometric readings. The Pulfrich refractometer has an inherent error of 0.00009, while the error of the Abbe instrument is about the same, being approximately 0.0001. It is obvious therefore, as Robertson remarks, that, since the absolute error in the determination of $n - n_1$ is the same, the error in the determination of a must be less in proportion to the magnitude of c . It is therefore desirable to use as concentrated solutions as possible when determining the value of a . But maximum concentrations of proteins cannot be used because when a certain concentration is exceeded the border line seen in the field of the instrument becomes hazy and accurate setting of the instrument is impossible.

The present investigation was undertaken to find out whether the concentration of hemoglobin in solution might be estimated by the refractometric method, and to establish the value of a for hemoglobin. If this could be done it was obvious that a useful method might be devised for estimating hemoglobin in blood.

Methods.

The index of refraction was measured by an Abbe refractometer by Zeiss loaned by the Physics Department of Williams College through the courtesy of Prof. W. E. McElfresh. This type of refractometer, while less commonly used than is that of Pulfrich, is nevertheless very satisfactory. If allowed to attain the temperature of the room in which it is used, and if the room temperature is kept approximately constant, there is no difficulty in making several successive observations at the same temperature. The prisms are, however, water-jacketed and can be connected with a constant temperature reservoir if desired. This was not found necessary in the present work. All readings were made at 19-21°C., and in determining the value of $n - n_1$ the two readings necessary were made in quick succession and therefore at the same temperature. As the apparatus is provided with a compensating device to correct dispersion, a sodium flame or other source of monochromatic light is unnecessary. In this work an ordinary incandescent lamp was used as the source of light. The scale of the instrument is so constructed that the index of refraction

can be read directly from the graduated arc. The smallest subdivisions of the scale represent intervals of 0.001, but with some practice it is possible to estimate tenths of a subdivision with fair accuracy. It has therefore been assumed in this work that the error in reading is ± 0.0001 , but with care it is probable that the error can be reduced below this value. Several settings and readings were made for each determination and the average was taken. Consequently figures extending to the fifth decimal have occasionally been used with some confidence.

The work undertaken can be conveniently described in four parts; *viz.*, (A) preparation of pure hemoglobin, (B) examination of the validity of the formula $n - n_1 = a \times c$ when applied to hemoglobin solutions, (C) investigation of the possible effect of dilute alkalis and of serum constituents on the refractivity of hemoglobin, and (D) determination of the value of a for hemoglobin.

(A) *Methods of Preparation of Hemoglobin.*

Most of the crystallized hemoglobin used in this investigation was made by the method of Hoppe-Seyler as modified by Hüfner,³ and especially as modified in some details by Butterfield.⁴ In the case of hemoglobin from the guinea pig and the rat crystallization from laked blood took place readily in the cold without the addition of alcohol. Preparations from these species were, however, of little value for the purpose in hand because of their very sparing solubility. In the case of dog, horse, and beef bloods, alcohol was added to the laked blood, after cooling to 0°C., to make a concentration of from 20 to 30 per cent. The actual effective concentration was uncertain, and may have been higher than 30 per cent in some cases as ice crystals usually separated out at the low temperatures employed (-10 to -20°C.) thus raising the concentration of alcohol in the solution. Crystallized hemoglobin was separated by centrifugalization, washed twice with 25 per cent alcohol, and finally dried on a porous plate *in vacuo* over H₂SO₄ at or close to 0°C.

Hemoglobin prepared in this way always contained a small and variable proportion of material insoluble in water but soluble in dilute alkali. This probably consisted of serum globulin and of stromata of corpuscles that had escaped solution by the ether, and that had been carried down by hemoglobin crystals in the centrifuge. It was found that after apparently thorough hemolysis of corpuscles by ether it was still possible to demonstrate stromata in the apparently clear liquid. If a drop of this liquid was mixed with a drop of saturated ammonium sulfate solution and examined under the microscope it was always possible to find some stro-

³ Hüfner, G., *Arch. Physiol.*, 1894, 134.

⁴ Butterfield, E. E., *Z. physiol. Chem.*, 1909, lxii, 173.

mata, often in the typical bell-shaped form of erythrocytes. The salt did, of course, precipitate some of the hemoglobin, but there was no difficulty in distinguishing the stromata from the granular hemoglobin precipitate.

An effort was made to remove the stromata by filtration, but without success. Shaking the laked blood with filter paper pulp or with siliceous earth followed by filtration through asbestos felt at four atmospheres pressure was ineffective. As long as the solution came through the filter at all it carried stromata with it, but the flow stopped after a few cc. had filtered through. Centrifugalization was wholly ineffective in separating the stromata, as other investigators also have remarked.

When, however, hemoglobin prepared as above described was dissolved in water it was possible to separate the insoluble impurity by centrifugalization, to wash, dry, and weigh it, and then to calculate its percentage in the hemoglobin. But such a procedure probably gives inaccurate results and cannot be adopted with satisfaction.

After numerous unsuccessful efforts to get entirely consistent results with hemoglobin made as described, the paper of Welker and Williamson⁵ appeared calling attention to the method of removing colloids from solution devised by Marshall and Welker.⁶ The latter authors had shown that it is possible to remove entirely colloids *other than hemoglobin* from solutions by treatment with aluminum hydroxide. With this method, it was found that by shaking a laked corpuscle preparation with a freshly prepared mass of aluminum hydroxide, the colloids, other than hemoglobin, were adsorbed and suspended matter was entangled by the hydroxide and that a perfectly clear solution of hemoglobin, together with salts, could be filtered off with the utmost readiness. This method is of such excellence as to warrant the opinion that much of the work on hemoglobin in the past, in which discordant results have been obtained, might well be repeated using the method of Marshall and Welker for the preparation of the pure substance. All the observations included in the results published in the present paper, except where otherwise stated, were made on hemoglobin prepared from solutions thus purified. The technique of preparation was essentially that of Butterfield with the addition of the aluminum hydroxide purification after laking the blood and before the addition of alcohol.

⁵ Welker, W. H., and Williamson, C. S., *J. Biol. Chem.*, 1920, xli, 75.

⁶ Marshall, J., and Welker, W. H., *J. Am. Chem. Soc.*, 1913, xxxv, 820.

(B) *Examination of the Validity of the Formula $n - n_1 = a \times c$ for Hemoglobin.*

As has already been stated, the refractivity of most proteins in solution is a linear function of their concentration. When the optical behavior of hemoglobin in this respect was examined it was found that within the limit of the inherent experimental error, the refractivity was directly proportional to the concentration. Experiment 1 demonstrates this agreement with the law.

Experiment 1.—The material used for this experiment consisted of twice washed horse corpuscles, laked with ether, then freed from ether by aspirated air, and finally treated with aluminum hydroxide. It contained about 17 per cent of hemoglobin and a small amount, probably about 1 per cent, of salts. 1 cc. of this solution was placed in each of six tubes, and to each tube was added from a calibrated pipette of 3 mm. bore enough distilled water to make the dilution 90, 80, 70, 60, 40, and 20 per cent respectively in the several tubes. After the liquid in each tube had been mixed, the refractive index was measured as well as the refractive index of the original solution. Table I gives the results of this experiment.

TABLE I.

	$n - n_1$	$\frac{n - n_1}{\text{relative concentration}}$
Original solution.....	0.0310	0.0031 \pm 0.00001
90 per cent dilution.....	0.0282	0.0031 \pm 0.00001
80 " " "	0.0251	0.0031 \pm 0.00001
70 " " "	0.0216	0.0031 \pm 0.00001
60 " " "	0.0187	0.0031 \pm 0.00002
40 " " "	0.0124	0.0031 \pm 0.00003
20 " " "	0.0062	0.0031 \pm 0.00005

(C) *Refractivity of Hemoglobin in Water, in Dilute Alkali, and in Serum.*

As⁷ it was desired to use as solvents both dilute alkali and serum, it was necessary to find out whether the refractivity of hemoglobin was the same in each of the solvents. It had been shown by Gladstone and Dale⁷ that in general the refractivity of

⁷Gladstone, J. H., and Dale, T. P., *Phil. Trans. Roy. Soc.*, 1858, cxlviii, 8; 1863, cliii, 316.

a solute is uninfluenced by other solutes provided no molecular change is induced, and Robertson⁸ has shown that this general truth applies to protein. The latter has further shown that the relatively slight alteration of molecular structure that occurs when proteins unite with acids or bases does not sensibly alter the refractivity, but, on the other hand, that the change in the degree of hydration that occurs when amorphous serum albumin solution is half saturated with ammonium sulfate does cause a notable change in the refractive index. With these facts in mind there would seem to be no reason to anticipate that the refractivity of hemoglobin in dilute alkali or in serum would be different from that in water, but the result of the experiment is conclusive. The refractivity of hemoglobin in these solvents is normal.

Experiment 2.—The refractive index of a solution of hemoglobin of about 17 per cent strength, and that of a 0.1 N NH₄OH solution were first determined, 1 cc. of each of these solutions was mixed together, and the refractive index of the mixture determined. It is evident that if the refractivity of the hemoglobin remained normal in the presence of 0.05 N NH₄OH then the refractive index of the mixture would be equal to the mean of the refractive indices of the component solutions. A parallel experiment with hemoglobin and serum was also made. The results follow.

Hemoglobin in Dilute Alkali.

(1) <i>n</i> of hemoglobin solution.....	1.3661
(2) <i>n</i> of 0.1 N NH ₄ OH	1.3341
Mean of refractive indices of (1) and (2).....	1.3501
<i>n</i> of mixture of equal parts of (1) and (2).....	1.3501

Hemoglobin in Serum.

(1) <i>n</i> of hemoglobin solution.....	1.3667
(2) <i>n</i> of serum.....	1.3440
Mean of refractive indices of (1) and (2).....	1.35535
<i>n</i> of mixture of equal parts of (1) and (2).....	1.3553

(D) Determination of the Value of α for Hemoglobin.

1. By Means of Solutions of Pure Crystallized Hemoglobin.—

Experiment 3.—Tubes 8 by 120 mm. each containing a glass bead were prepared and weighed. Crystallized dry hemoglobin was weighed in the

⁸ Robertson, T. B., *J. Biol. Chem.*, 1912, xi, 179.

tubes and the tubes were nearly filled with 0.1 N NH_4OH . The amount of hemoglobin was chosen to make approximately a 10 per cent solution. Solution was effected by warming in a bath at 30°C . and by thorough shaking. The tube was then centrifugalized to destroy the foam and a few drops of the solvent were added to facilitate observation of the meniscus. The level of the meniscus was carefully marked on the tube, the con-

TABLE II.

Concentration of Hb.	$n - n_1$	a
9.66	0.0178 ± 0.0001	0.001842 ± 0.00001
10.89	0.0198 ± 0.0001	0.001819 ± 0.00001
Average		0.001830 ± 0.00001

TABLE III.

Source of blood.	Concentration.	$n - n_1$
Guinea pig.	2.08	0.00365
	2.45	0.00425
Rat.	2.00	0.00320
	4.30	0.00770
Dog.	3.63	0.00630
	3.75	0.00610
	3.93	0.00700
	4.30	0.00755
	9.30	0.01800
Horse.	6.19	0.01160
	7.66	0.01360
Ox.	2.77	0.00485
	2.95	0.00555
	6.26	0.01065
	7.06	0.01275
	7.89	0.01385

Average value of $a = 0.00178 \pm 0.00002$. In determining the value of a from a number of observations due allowance should be made for the greater accuracy of the values obtained from the more concentrated solutions; *i.e.*, a weighted average should be calculated. Following Robertson's suggestion this has been done by dividing the sum of the values of $n - n_1$ by the sum of the values of c .

tents were thoroughly mixed, and the refractive index was read. The tube was then washed and filled with distilled water to the mark, and weighed. The volume of the tube to the mark divided into the weight of hemoglobin gave the concentration of hemoglobin in the solution of which the refractive index had been read. From these data the value of a was calculated. Table II gives the results of two determinations on horse hemoglobin.

Before becoming acquainted with the aluminum hydroxide method of preparing pure hemoglobin, sixteen separate determinations of the value of a were made on specimens of hemoglobin prepared from the blood of the rat, guinea pig, dog, horse, and ox. It seems worth while to include the results of these observations (see Table III), although the value of a obtained is affected by the presence of the insoluble impurity to which reference has already been made, and is consequently slightly lower than the correct value given in Table II.

2. By Means of Hemoglobin Solutions Freed from Salts by Dialysis but Not Crystallized.—The hemoglobin molecule is very sensitive to denaturing influences. While the uniformity of results obtained by different recent observers who have determined the spectrophotometric constant of hemoglobin would incline one to the conclusion that they were dealing with a sufficiently stable substance, yet the divergence of results of proximate analyses make it possible that either the alcohol used to bring about crystallization, or the subsequent drying, results in a preparation that is to some extent dehydrated or denatured, and possibly with an altered refractivity. With this possibility in view the value of a was calculated from hemoglobin that had not been subjected to any dehydrating agent and that had not been crystallized. The following procedure was employed.

Experiment 4.—Ether-laked blood was purified by aluminum hydrate and then dialyzed in a Schleich and Schüll thimble until the dialysate gave no precipitate with AgNO_3 , and its refractive index was the same as that of pure water. Such a solution is free from colloids and suspended matter, and sufficiently free from salts for the purposes of this investigation. The value of $n - n_1$ (n_1 of distilled water) for this solution was determined and then an accurately measured volume was evaporated in a drying oven, and the weight of the dry residue determined in the usual way. The concentration of hemoglobin was calculated from the volume of the solution and the weight of dry residue. The following result was obtained.

Concentration of Hb.

per cent

 $n - n_1$ α

13.23

0.0242

0.00183 \pm 0.000008

3. *By Refractometric Comparison of Laked and Unlaked Blood, with Gasometric Determination of Hemoglobin.*—Unlaked blood offers an exceptionally favorable opportunity for measuring the refractivity of hemoglobin; for in unlaked blood the hemoglobin, remaining in the corpuscles, does not affect the refractive index, the refractive index of whole blood being identical with that of the plasma.⁹ On laking, the hemoglobin is discharged from the corpuscles, and entering into solution in the plasma raises its refractive index by an amount proportional to the percentage of the hemoglobin in the blood. This statement involves the assumption that freezing and thawing cause, first, the complete discharge of all the hemoglobin, and, second, an inappreciable discharge of electrolytes and water. The first assumption can be readily tested. It was found that alternately freezing and thawing blood three times caused a rise in the refractive index that was not increased by further freezing and thawing, and from blood so treated no sediment could be obtained on centrifugalization. The extent to which water and electrolytes are discharged from the corpuscles by hemolysis cannot be so easily determined. Stewart¹⁰ has observed the change in conductivity of serum following hemolysis produced by various agencies, and has concluded that freezing and thawing cause a less discharge of electrolytes than does any other agency. He was unable to estimate with precision the possible increase of electrolytes in the serum because the entrance of hemoglobin itself into the serum lowers the conductivity by opposing the migration of ions and by putting back the dissociation of electrolytes. From the results of Stewart's work, however, it seems probable that any change in the refractivity of the serum due to the entrance of water and electrolytes from the corpuscles must be of a very low order of magnitude. Moreover the concordance between the result of the present experiment, based on this assumption,

⁹ When whole blood is first observed in the refractometer the border line is very hazy, but within 30 seconds it becomes quite sharply defined.

¹⁰ Stewart, G. N., *J. Physiol.*, 1899, xxiv, 211.

and the results of other methods of determining the value of a speaks for the correctness of the assumption itself.

The gasometric method of determining the oxygen of blood devised by Van Slyke¹¹ furnishes an accurate method of estimating the percentage of hemoglobin, for it is known that 1 cc. of oxygen combines with 0.744 gm. of hemoglobin.¹²

Experiment 5.--The oxygen capacity of human blood, oxalated and thoroughly oxygenated by rolling for 20 minutes in a large bottle, was measured in the Van Slyke apparatus. Only two drops of octyl alcohol, redistilled at 35 mm. pressure and tested, were used, and saponin was dispensed with to make it practicable to use so small an amount of foam preventer. The average of five closely concordant readings was 0.418 cc. The calculated amount of oxygen was 16.97 cc. per 100 cc. of blood, and the calculated percentage of hemoglobin 12.625 (16.97×0.744).

1 cc. of the same blood was sealed in a tube and alternately frozen and thawed four times. The refractive index of the perfectly clear liquid was then measured and found to be 1.3697. The refractive index of the whole blood (or of the plasma) was 1.3466. The difference between these two figures, the refractivity of the hemoglobin, is 0.0231, and this number divided by the concentration of the hemoglobin (12.625) gives 0.00183 ± 0.000008 , which is the value of a .

CONCLUSIONS.

The object of this investigation was the determination of the value of a for hemoglobin. When reached by three separate and distinct methods the result has proved to be the same; namely, $a = 0.00183$. It is therefore believed that this figure can safely

¹¹ Van Slyke, D. D., *J. Biol. Chem.*, 1917, xxx, 347; 1918, xxxiii, 127.

¹² It has been conclusively shown by Peters (Peters, R. A., *J. Physiol.*, 1912, xlv, 131) and by Barcroft and Burn (Barcroft, J., and Burn, J. H., *J. Physiol.*, 1913, xlv, 493) that loosely combined oxygen and iron are associated in oxyhemoglobin in the proportion of 1 molecule of oxygen to 1 atom of iron; and Butterfield (Butterfield, E. E., *Z. physiol. Chem.*, 1909, lxii, 173) has determined the percentage of iron in oxyhemoglobin to be 0.335 per cent. Calculation from these data shows that 1 cc. of oxygen is combined with 0.744 gm. of hemoglobin.

No account has been taken in this work of the theoretical difference in the refractivities of oxyhemoglobin and hemoglobin. As molecular refractivity is an additive function of atomic refractivity the introduction of 2 atoms of oxygen into the enormous hemoglobin molecule would affect the refractivity to a quite inappreciable extent only.

be used to calculate the strength of hemoglobin solutions of unknown concentration when the value of $n - n_1$ can be found.

With the value of a determined, and with the knowledge that the difference in the refractive indices of laked and unlaked blood is due practically entirely to the hemoglobin, it is evident that a simple and fairly accurate clinical method of estimating hemoglobin in blood can be devised. The details of a clinical method, employing saponin hemolysis, are now being worked out. This technique together with data regarding the degree of accuracy obtainable will be communicated later.

SUMMARY.

1. It has been shown that the refractive index of solutions of hemoglobin varies directly with the concentration.

2. The refractive index of hemoglobin in aqueous solution has been shown to be independent of the presence of other proteins, and of bases and salts in low concentration.

3. The value of a for hemoglobin has been determined to be 0.00183.

4. The possibility of a practical clinical method for the refractometric estimation of hemoglobin has been indicated.

The advice and collaboration of Professor G. A. Shook, now of Wheaton College, Norton, Mass., but at Williams College at the beginning of this investigation in 1917, were of great value. On the resumption of the investigation, interrupted by the war, Professor Shook's absence made his cooperation no longer possible. He has, however, independently devised and reported¹³ a differential refractometer which it is believed can be conveniently used with this method.

The facilities of the Chemical Laboratory of Williams College were made available when necessary for this work through the kindness of Professor Brainerd Mears.

¹³ Shook, G. A., *J. Ind. and Eng. Chem.*, 1918, x, 553.

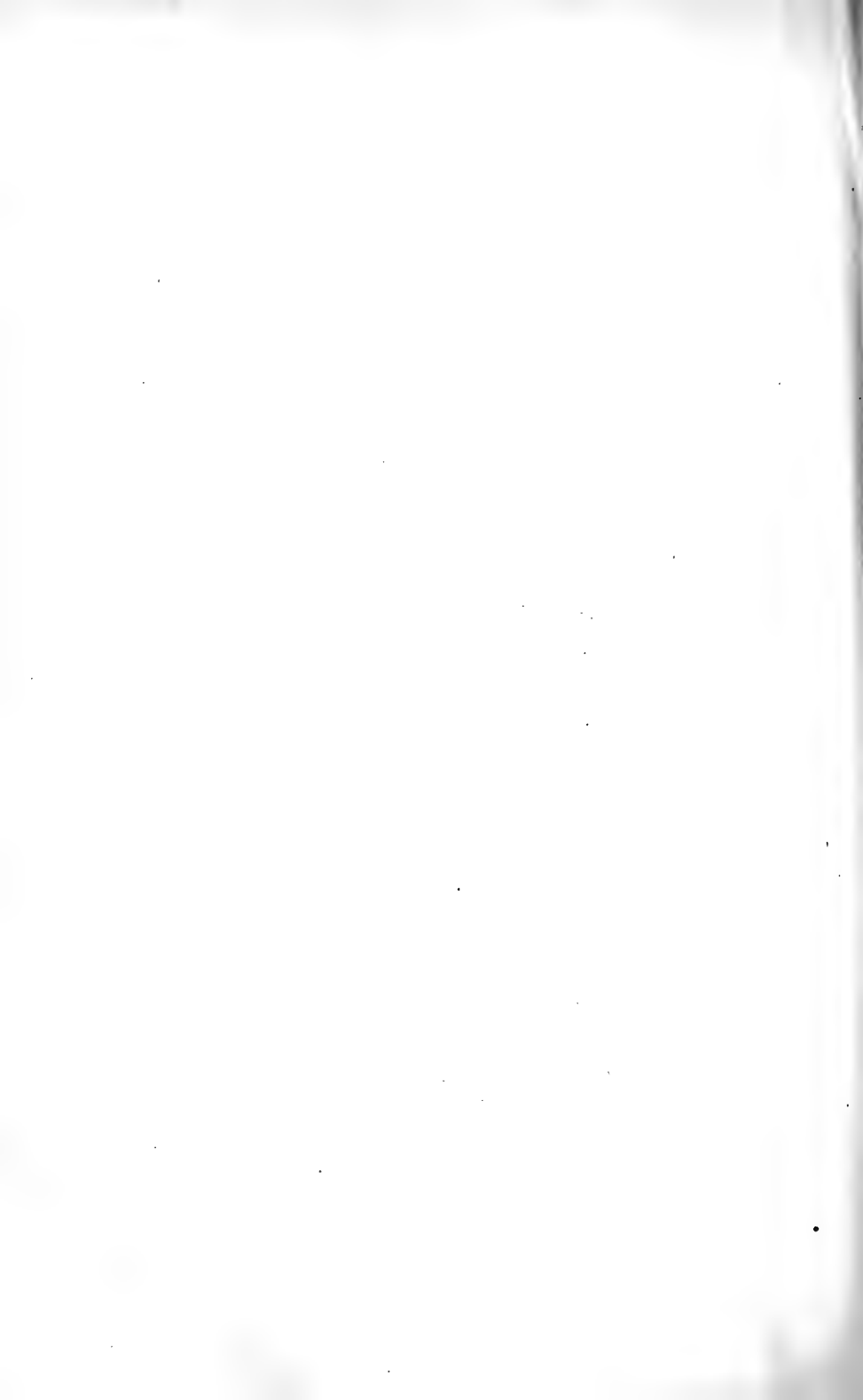

NUTRITIVE FACTORS IN PLANT TISSUES.*

IV. FAT-SOLUBLE VITAMINE.

BY THOMAS B. OSBORNE AND LAFAYETTE B. MENDEL.

WITH THE COOPERATION OF ALFRED J. WAKEMAN.

(From the Laboratory of the Connecticut Agricultural Experiment Station
and the Sheffield Laboratory of Physiological Chemistry, Yale
University, New Haven.)

(Received for publication, February 16, 1920.)

The occurrence of fat-soluble vitamine in green foods has been demonstrated for alfalfa, clover, and timothy plants and for the leaves of spinach and cabbage.¹ From some of these we have obtained potent products by drying the plant tissues in a current of air at about 60° and then extracting them with U. S. P. ether.² The resultant green extracts from spinach leaves, young clover, alfalfa, and grass respectively yielded an oily residue approximating 3 per cent of the dried plant.³ These residues, fed in daily quantities equivalent to 1 to 2 gm. of the dried plant, promoted recovery and renewal of growth in rats declining in weight on diets deficient in fat-soluble vitamine. McCollum, Simmonds, and Pitz⁴ have stated that "ether extraction of plant tissue does not remove the substances essential for growth which is contained in butter fat." The results of our successful experience,

* The expenses of this investigation were shared by the Connecticut Agricultural Experiment Station and the Carnegie Institution of Washington, Washington, D. C.

¹ For a discussion of the literature see Osborne, T. B., and Mendel, L. B., *J. Biol. Chem.*, 1919, xxxvii, 187.

² Osborne, T. B., and Mendel, L. B., *Proc. Soc. Exp. Biol. and Med.*, 1918-19, xvi, 98.

³ The actual content of substance removed from a number of samples of dried plant tissues in this way was as follows: spinach, 3.0 and 4.3 per cent; young alfalfa, 3.0 per cent; green grass, 4.1 per cent; timothy, 4.2 per cent; tomato, 2.8 per cent.

⁴ McCollum, E. V., Simmonds, N., and Pitz, W., *Am. J. Physiol.*, 1916, xli, 363.

however, are illustrated in Chart I. The food mixtures had the composition as given in Table I.

Although dried tomato was efficacious as a source of fat-soluble vitamine, its ether extract was not (see Chart II).

Recently Steenbock and Gross⁵ have concluded that:

“ . . . tubers and roots are not necessarily to be classed with food materials grossly deficient in their fat-soluble vitamine content. While in some instances it is true that there is little or no fat-soluble vitamine demonstrable, in other instances there is enough present to warrant their classification with respect to their content of this dietary essential with leafy materials rather than with our cereal grains such as maize, wheat, barley, or oats.”

TABLE I.

Food.	Rats 5411, 5412, 5417, 5425, 5430.	Rats 5570, 5563.	Rat 5527.
	<i>per cent</i>	<i>per cent</i>	<i>per cent</i>
Meat residue.....	19.6		
Casein.....		18.0	
Lactalbumin.....			18.0
Salt mixture*.....	4.0	4.0	4.0
Starch.....	52.4	48.0	47.0
Lard.....	24.0	30.0	31.0
Yeast.....	0.2-0.6 gm. daily.	0.4 gm. daily.	0.4 gm. daily.

* The composition of the salt mixture is given in Osborne, T. B., and Mendel, L. B., *J. Biol. Chem.*, 1919, xxxvii, 572.

We are not familiar with any published determinations of the *absolute* quantity of carriers of fat-soluble vitamine necessary to keep growing animals in health and vigor. It has been reported that for rats 2 per cent of butter fat is sufficient for the maintenance of good growth when all other dietary factors are of good quality,⁶ although Drummond⁷ who has had large experience in this field has failed to secure normal growth of rats with even 4 per cent of butter fat in an otherwise suitable diet. Early in our studies of the fat-soluble vitamine we⁸ secured good growth for

⁵ Steenbock, H., and Gross, E. G., *J. Biol. Chem.*, 1919, xl, 529.

⁶ McCollum, E. V., Simmonds, N., and Parsons, H., *J. Biol. Chem.*, 1919, xxxvii, 162.

⁷ Drummond, J. C., *Biochem. J.*, 1919, xiii, 81, Experiments 1 to 10, 85.

⁸ Osborne, T. B., and Mendel, L. B., *J. Biol. Chem.*, 1915, xx, 379.

long periods on diets containing 1 and 3 per cent of butter fat respectively along with protein-free milk; ultimately a decline ensued and body weight was restored by increasing the content of butter fat in the food mixture.

Without knowledge as to the total food intake it is impossible to estimate the absolute amount of butter fat eaten with any approach to accuracy. However, rats usually eat enough of diets thus poor in fats to make it unlikely that the minimum quantity of butter fat ingested daily in the case of the 2 per cent fat ration would be less than 150 to 200 mg.

In contrast with this we have observed that only 42 mg. per day of the U. S. P. ether extract of grass sufficed to furnish enough fat-soluble vitamine to promote renewal of growth in rats that had declined on diets deficient in this factor. Furthermore in a number of instances the now familiar eye disease that frequently afflicts rats which have been for some time on a diet deficient in fat-soluble vitamine was cured after the administration of ether extracts of alfalfa, grass, or spinach (see Chart I, Rats 5417, 5570, 5425, 5563).

The foregoing observations have raised the question as to the comparative potency of green vegetables, roots, *etc.* as sources of fat-soluble vitamine in contrast with the more familiar carriers represented in the fats of milk, egg, *etc.*—products already demonstrated to furnish this essential food factor. To secure evidence we have fed rats, beginning with approximately the same age and size, on a diet complete in respect to each known essential except fat-soluble vitamine. The basal food mixture consisted of:

	<i>per cent</i>
Meat residue.....	19.6
Salt mixture*.....	4.0
Starch.....	52.4
Lard.....	24.0
Yeast.....	0.4 gm. daily.

* The composition of the salt mixture is given in Osborne, T. B., and Mendel, L. B., *J. Biol. Chem.*, 1919, xxxvii, 572.

The quantity of brewery yeast added as a source of water-soluble vitamine has been demonstrated by us to be ample and

also practically free from fat-soluble vitamine.⁹ Upon the diet outlined rats soon fail to grow and then begin to decline rapidly in body weight, as shown in Chart III, Rats 5496, 5491, and 5512. Unless the physiological damage has proceeded too far, restoration of growth and well being is usually readily brought about by inclusion of butter fat in place of part of the lard in the food mixture. The characteristic eye conditions or symptoms, sometimes termed xerophthalmia or perhaps better keratomalacia, which often develop during the decline in health,¹⁰ are speedily relieved when the nutritive conditions begin to improve.

To test the comparative efficacy of various products as sources of fat-soluble vitamine they were fed, apart from the food mixture, in daily doses of approximately 0.1 gm. of the dried substance.¹¹ These were consumed with readiness by the animals so that a fairly constant supply of the product to be tested was always ingested, despite variations in the total food intake.

The products used were prepared from the plant materials by heating in a large drier, through which a current of air circulated at 60° or less, and grinding the dry residues to a powder.

The changes in body weight of the animals in this series of experiments are shown in Charts IV to XI. Whenever any of the animals began to decline in body weight and thus give evidence of unsatisfactory nutrition the diet was changed by the addition of 18 per cent of butter fat to the food mixture, in order to ascertain whether a shortage of the fat-soluble factor was the real cause for the failure of maintenance.

To permit comparison with a more familiar source of fat-soluble vitamine a series of rats was fed 0.1 gm. of butter fat daily instead of the dried vegetable. With a food intake of 50

⁹ We have referred to this fact in earlier papers; *e.g.*, Osborne, T. B., and Mendel, L. B., *J. Biol. Chem.*, 1917, xxxi, 158; 1919, xxxvii, 199. See also Drummond, J. C., *Biochem. J.*, 1917, xi, 255.

¹⁰ We cannot accept the implication of Bulley, E. C., *Biochem. J.*, 1919, xiii, 103, that lack of fat-soluble vitamine plays no decisive rôle in the appearance of the symptoms of eye disease. Our evidence will be presented at another time.

¹¹ The materials were measured with small scoops which did not deliver exact quantities. The \pm variations were found subsequently to amount to 40 per cent in a few instances. This does not materially alter the significance of the results.

to 70 gm. per week, which we¹² have found usual for animals of the same size on adequate foods of similar calorie value, this amount of butter fat would be equivalent to that in a mixture containing 1.4 to 1.0 per cent thereof. Chart III contrasts the records of rats that received no butter fat and began to decline in 50 to 60 days with the weight curves of ~~three~~ rats which were fed 0.1 gm. of butter fat daily and reached a maximum weight of 290, 310, and 320 gm. respectively before giving any indication of qualitative inadequacy of their diet. Rat 5300 could no longer be restored by the administration of butter fat; the other two animals, however, showed a slight response to this product, indicating that they may have suffered somewhat from a lack of the fat-soluble factor found therein.

The growth of rats to adult size upon diets in which the daily intake of butter fat as a source of fat-soluble vitamine was as small as in the experiments just described was surprisingly good. It should be borne in mind that, in contrast with what is true of animals having declined through complete deprivation of some requisite food factor, the problem of dosage for vitamins may be quite different in the case of rats which are supplied with a minimum of the essentials throughout the period of growth. When the other dietary factors were satisfactory we have repeatedly found 0.5 gm. of butter fat per day to be sufficient to restore to good nutritive condition and growth rats declining on diets devoid of fat-soluble vitamine. This corresponds, for our food mixtures, to a butter fat content of about 5 per cent. How much less might suffice, we cannot state at present.

If butter fat, which has been studied more extensively than any other source of fat-soluble vitamine, is used as a standard for comparison the relatively large content of fat-soluble vitamine in some of the vegetable products examined is at once suggested by inspection of our records. For example, two rats (Nos. 5385 and 5386, Chart IV) receiving only 0.1 gm. of tomato daily have rapidly grown to exceptionally large adult size and have not shown any signs of a failure of nutrition at the end of 394 days. In considering this unexpectedly good physiological performance it must be remembered that the more rapid growth

¹² Osborne, T. B., and Mendel, L. B., *J. Biol. Chem.*, 1915, xx, 351.

at the start may have been facilitated by the additional supply of water-soluble vitamine (water-soluble B) furnished by the tomato, which we¹³ have demonstrated to be rich in this factor.

It may be necessary to take into consideration another factor supplied by the dried tomato. Givens and McClugage¹⁴ have shown that the latter, in contrast with some other vegetable foods, may retain a significant amount of its antiscorbutic potency. Is the exceptionally good growth of the tomato-fed rats attributable to this? Although it has generally been assumed that rats are not susceptible to scurvy both Harden and Zilva¹⁵ and Drummond¹⁶ maintain that this species also requires antiscorbutic vitamin. Thus Harden and Zilva conclude:

" . . . rats existing on a scorbutic diet, although capable of gaining in weight and reproducing themselves, without any apparent manifestation of pathological symptoms for months, do not thrive so well as animals which have their diets supplemented with an antiscorbutic. This suggests that although rats are not very susceptible to scurvy they cannot absolutely dispense with antiscorbutics without restriction of their normal development."

The evidence of all these English investigators consists in the demonstration of the attainment of larger size by rats which received orange juice or lemon juice as an antiscorbutic in addition to yeast as a source of water-soluble vitamine. It is not clear, however, that the fruit products did not function merely as added sources of water-soluble B which we have found them to contain,¹⁷ and thus promote the rate of growth by the increment of a factor other than the antiscorbutic. We have frequently observed improved growth in rats when the supply of vitamine from yeast was increased. Without a demonstration that more yeast, which is not regarded as antiscorbutic, or some other source of water-soluble B should fail to accomplish what is claimed for orange juice added to yeast, the conclusion of the

¹³ Osborne, T. B., and Mendel, L. B., *J. Biol. Chem.*, 1919, xxxvii, 187; 1920, xli, 451.

¹⁴ Givens, M. H., and McClugage, H. B., *J. Biol. Chem.*, 1919, xxxvii, 253.

¹⁵ Harden, A., and Zilva, S. S., *Biochem. J.*, 1918, xii, 408.

¹⁶ Drummond, J. C., *Biochem. J.*, 1919, xiii, 77.

¹⁷ Osborne, T. B., and Mendel, L. B., *Proc. Soc. Exp. Biol. and Med.*, 1919-20, xvii, 46.

need of some special antiscorbutic by rats is not convincing: We have on several occasions attempted without success by giving orange juice or tomato to promote the growth of rats that failed to respond properly to yeast as a source of water-soluble vitamine. However, it should be pointed out that occasionally animals which fail to grow on our food mixtures as well as one might expect begin to thrive when a mixed diet is furnished. The reason for this is not yet clear.

Among the various dried vegetables tested for their comparative content of fat-soluble vitamine the cabbage was least satisfactory (see Rats 5247, 5248, 5297, Chart V). The ready response of two of the animals to additions of butter fat to the diet indicates the character of the deficiency in the cabbage. 0.1 gm. of alfalfa, clover, timothy, and spinach evidently furnishes relatively at least as much of this vitamine as does 0.1 gm. of butter fat (see Charts VI, VII, VIII, and IX). These vegetable products may in fact contain more than butter fat.

Some of the animals receiving the dried green products grew to large adult size before evincing any signs of a possible shortage of fat-soluble vitamine. Eye disease characteristic of a lack of this vitamine was not observed in any of these animals.

Tests with dried carrots are shown in Chart X. The experiments with potato (including the skin), Chart XI, are not strictly comparable with the others inasmuch as the quantities of the tuber used, *i.e.* 20 per cent of the food, were large. The large size attained by two of the rats on the potato food indicates that the tuber as a whole cannot be entirely devoid of fat-soluble vitamine.

In an investigation of the distribution of fat-soluble vitamine in some roots Steenbock and Gross⁵ have recently concluded:

"With 15 per cent of the diet made up of roots as the source of the fat-soluble vitamine we have in the case of the yellow sweet potato and carrot normal growth and even rearing of the young made possible, but in the case of the rutabaga, dasheen, red beet, parsnip, potato, mangel, and sugar beet complete failure resulted."

In the experiments of these investigators larger quantities of potato in the diet, however, permitted growth, this corresponding with our observation that this tuber, though poor in fat-soluble vitamine, is by no means entirely devoid of it.

Early in our investigation of the properties of butter fat we reached the conclusion that the fat-soluble vitamine as it occurs in this natural product is not readily destroyed by heating with steam. "Butter fat through which live steam was passed for two and one-half hours or longer did not lose its characteristic restorative properties"¹⁸ when fed to rats which had declined on diets deficient in fat-soluble vitamine. We have since duplicated this observation.

Steenbock, Boutwell, and Kent¹⁹ and Drummond⁷ have reached the conclusion that the fat-soluble vitamine is readily destroyed by heat. Thus Drummond states, in confirmation of the claims of the American investigators:

"Exposure of butter fat to 100° for periods of from one to four hours destroys its growth promoting power entirely, so far as can be determined by experiments on young rats The effect of lower temperatures was also investigated and it was ascertained that the nutritive value of butter fat may be appreciably lowered by four hours' exposure to temperatures ranging from 50°-75°."²⁰

In comparing these statements with the findings which we published earlier it should be noted that the newer experiments have involved heating the fat *in the absence of water*. Our heated butter fat was subjected to steaming, not dry heat, for several hours. It seemed possible that the differences in the mode of heating, involving unlike possibilities of dehydration, *etc.*, might account for the discrepancies recorded. However, in experiments which will be reported in another paper we have since heated dry butter fat in an air bath at 96° for 15 hours without destroying sufficient fat-soluble vitamine (if any) to make the product appear inferior to the original butter fat when tested on rats that have declined from lack of fat-soluble vitamine.

We are not prepared to say that heat is without effect upon this vitamine, because we have not yet tested heated butter fat in quantities sufficiently small to meet the valid objection that despite some destruction sufficient amounts still remained in the

¹⁸ Osborne and Mendel,⁸ p. 381.

¹⁹ Steenbock, H., Boutwell, P. W., and Kent, H. E., *J. Biol. Chem.*, 1918, xxxv, 517.

²⁰ Drummond,⁷ p. 86.

large portion of heated fat fed to satisfy all requirements. We do know, however, that our animals *ate* all the heated butter fat apportioned to them, because it was fed apart from the food and not incorporated in the rest of the ration. In considering Drummond's experiments one is struck by the fact that even with 6 per cent of unheated butter fat in the diet²¹ his control rats grew at much less than the normal rate. This is contrary to the experience of several investigators, including ourselves, and raises a question as to the value of the untreated butter fat or the food intake of the animals used by him. At any rate the reason for the discrepancies between us are not apparent.

We have referred here in detail to some of these problems in connection with the effect of heat on the fat-soluble vitamine because it might be assumed that the low heat employed in desiccating the fresh foods studied in this research had diminished their content of fat-soluble vitamine. It is known that cabbage loses its antiscorbutic potency through drying; and this naturally suggests that the poor showing made by dried cabbage as a source of fat-soluble vitamine might also be ascribed to deterioration through heat and desiccation. The positive results secured with the other dried foods speak against such a conclusion. We have not yet made the crucial comparisons between the fresh and dried products. Drummond⁷ states in respect to his own observations that "the experiments with cabbage gave evidence that drying may reduce the efficiency of leaves as a source of fat-soluble A, but no definite opinion can yet be given." Drummond refers to the experiments on guinea pigs by Delf²² and Delf and Skelton²³ which lead them to believe that high temperature or the drying of cabbage leaves may effect a destruction of the fat-soluble accessory. Their experiments, however, seem to us to lack adequate controls and are not convincing. More recently Steenbock and Gross have asserted, in contrast with their findings regarding the thermolability of the vitamine in butter fat, that "the fat-soluble vitamine as found in plant materials was very stable to heat."²⁴

²¹ Drummond,⁷ p. 86, Experiment 6, Table I.

²² Delf, E. M., *Biochem. J.*, 1918, xii, 416.

²³ Delf, E. M., and Skelton, R. F., *Biochem. J.*, 1918, xii, 448.

²⁴ Steenbock and Gross,⁵ p. 506.

The newer studies indicating the richness of many types of plant tissues in those nutritive properties termed vitamins place the dietary importance of the green vegetables in an entirely new light. It emphasizes their use to supplement the refined foods of the modern food industry which furnish products rich in proteins, fats, and carbohydrates but in many cases comparatively deficient in the vitamins. The facts cited in the present investigation, along with others recently published, serve as an added reminder that the fat-soluble vitamin need not be sought solely in foods known to be rich in fats.

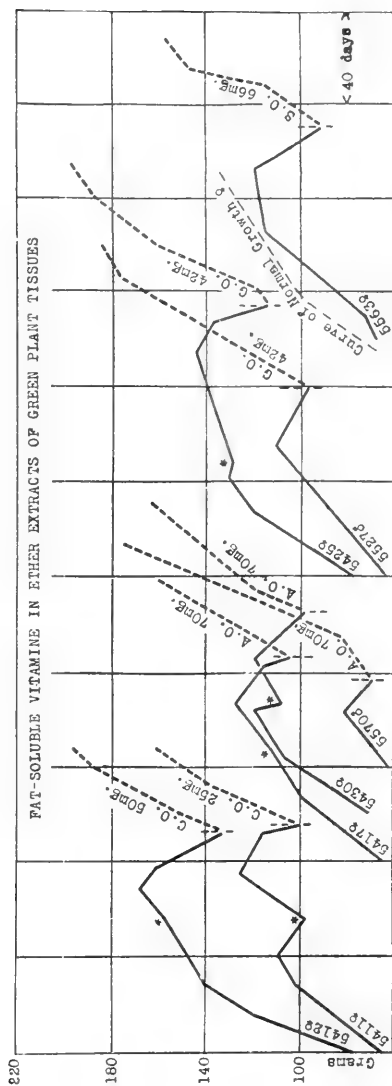

CHART I. Showing the efficiency of u. s. p. ether extracts from clover, alfalfa, grass, and spinach respectively as sources of fat-soluble vitamin in promoting restoration of growth in rats that had begun to decline on diets otherwise adequate. An asterisk (*) marks the period at which the daily allowance of dried brewery yeast, fed apart from the rest of the food, was increased to 0.6 gm. Note that this addendum alone sufficed to promote the growth of the animals for a time in some instances, although decline ultimately ensued in every case. Rats 5417, 5570, 5425, and 5563 developed the characteristic eye disease, which in each case disappeared after the administration of the plant oil. Interrupted lines indicate the periods during which the plant oils were fed mixed with starch and apart from the rest of the ration. C.O. = clover oil; A.O. = alfalfa oil; G.O. = grass oil; S.O. = spinach oil. The daily dose is indicated on the chart.

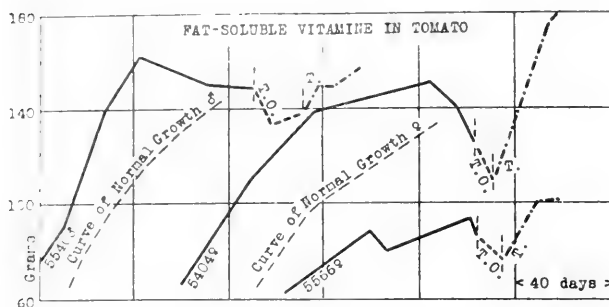

CHART II. Showing the failure of the ether extract of dried tomato (T. O.), in the quantities used, to promote renewal of growth in animals that had declined on a diet deficient in fat-soluble vitamine; and the renewal of growth when 1 gm. of dried tomato (T.) was furnished daily. The composition of the foods was as follows:

	Rat 5440♂.	Rat 5404♀.	Rat 5566♀.
	<i>per cent</i>	<i>per cent</i>	<i>per cent</i>
Casein.....	18.0		18.0
Meat residue....		19.6	
Salt mixture*....	4.0	4.0	4.0
Starch.....	48.0	52.4	48.0
Lard.....	30.0	24.0	30.0
Yeast.....	0.4 gm. daily.	0.2-0.6 gm. daily.	0.4 gm. daily.
Tomato oil.....	56-112 mg. "	56 mg. "	112 mg. "

* The composition of the salt mixture is given in Osborne, T. B., and Mendel, L. B., *J. Biol. Chem.*, 1919, xxxvii, 572.

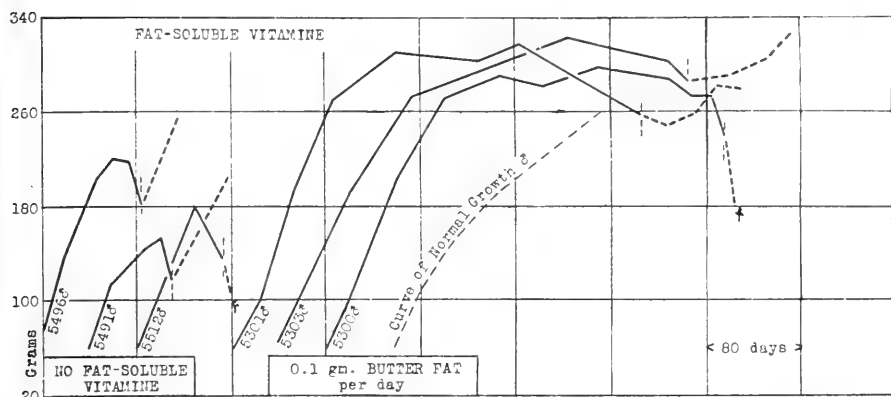

CHART III. Showing early failure to grow and decline of Rats 5496, 5491, and 5512 on a diet deficient in fat-soluble vitamin; also better growth of Rats 5301, 5303, and 5300 when 0.1 gm. of butter fat was supplied daily from the beginning of the experiment. The interrupted lines indicate the period during which 18 per cent of butter fat was included in the diet.

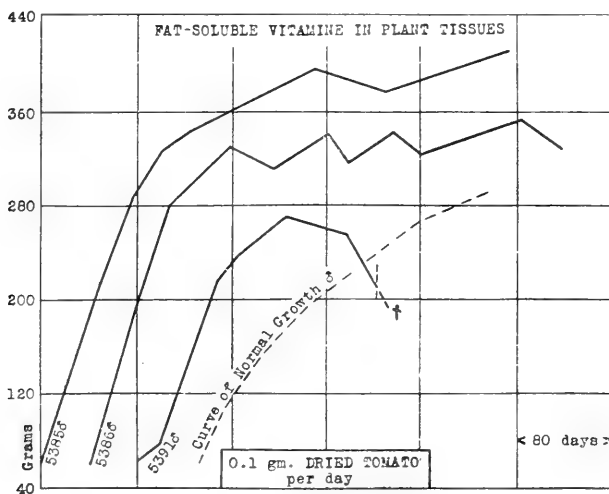

CHART IV. Showing the exceptional growth of rats on a diet containing 0.1 gm. of dried tomato as the source of fat-soluble vitamin. They represent the most successful growth observed in the entire series in this paper. Rat 5391 died of lung disease.

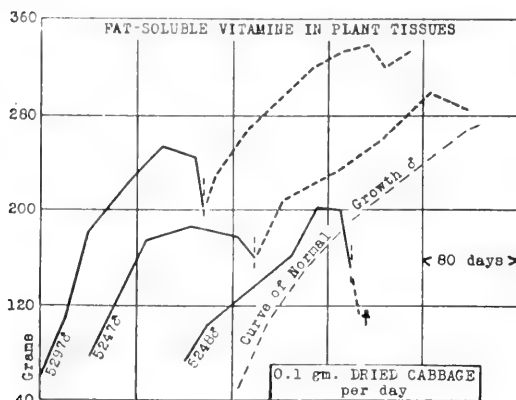

CHART V. Showing the inadequacy of 0.1 gm. of dried cabbage per day to supply sufficient fat-soluble vitamine to permit prolonged growth. The nature of the deficiency is shown by the renewal of growth when 18 per cent of butter fat was included in the diet during the period represented by the interrupted lines. That this amount of cabbage is not entirely lacking in fat-soluble vitamine is shown by the contrast of these results with the control experiments without fat-soluble vitamine, represented in Chart III.

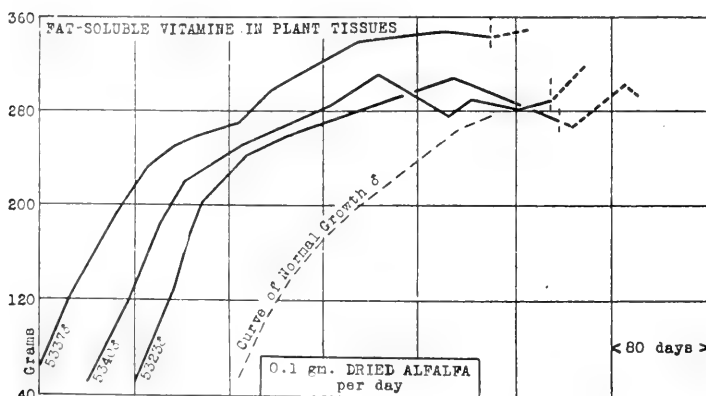

CHART VI. Experiments in which 0.1 gm. of dried alfalfa was fed daily in addition to a diet deficient in fat-soluble vitamine. The interrupted lines indicate the period during which 18 per cent of butter fat was included in the diet.

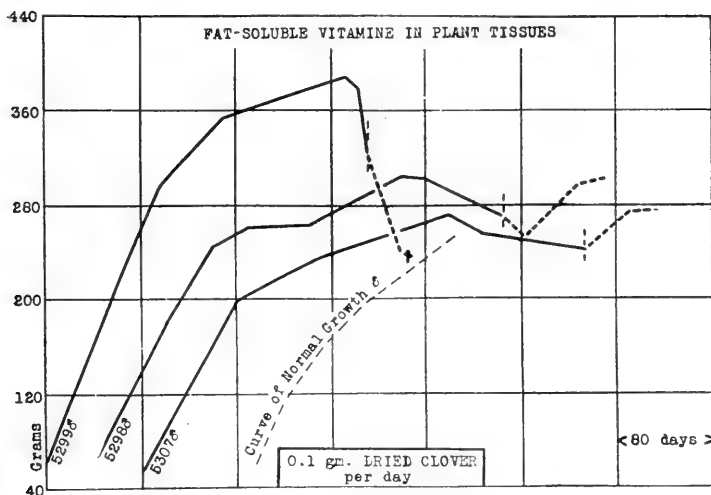

CHART VII. Experiments in which 0.1 gm. of dried clover was fed daily in addition to a diet deficient in fat-soluble vitamine. The interrupted lines indicate the period during which 18 per cent of butter fat was included in the diet. Rat 5299 died of lung disease.

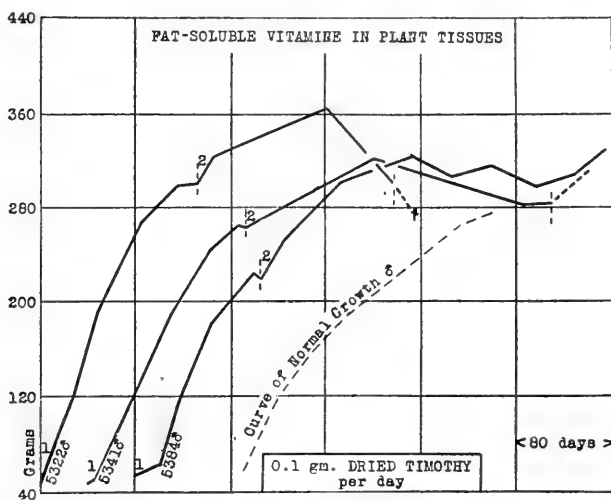

CHART VIII. Experiments in which 0.1 gm. of dried timothy (during Period 1) or 0.1 gm. of dried mixed grasses (during Period 2) was fed daily in addition to a diet deficient in fat-soluble vitamine. The interrupted lines indicate the period during which 18 per cent of butter fat was included in the diet.

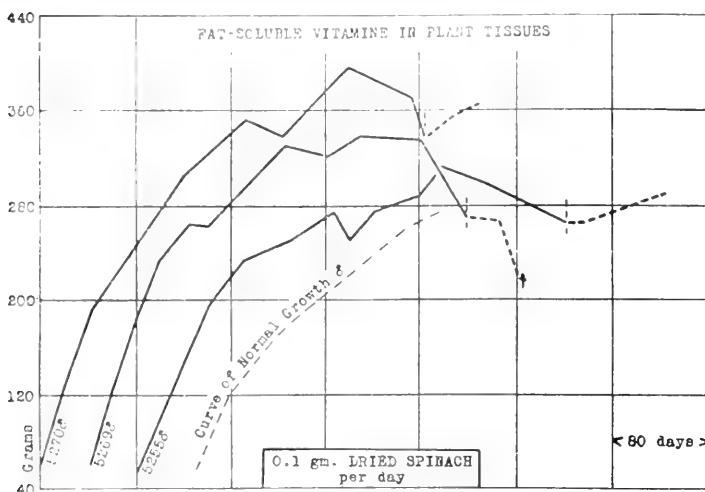

CHART IX. Experiments in which 0.1 gm. of dried spinach was fed daily in addition to a diet deficient in fat-soluble vitamine. The interrupted lines indicate the period during which 18 per cent of butter fat was included in the diet. Rat 5269 died of lung disease.

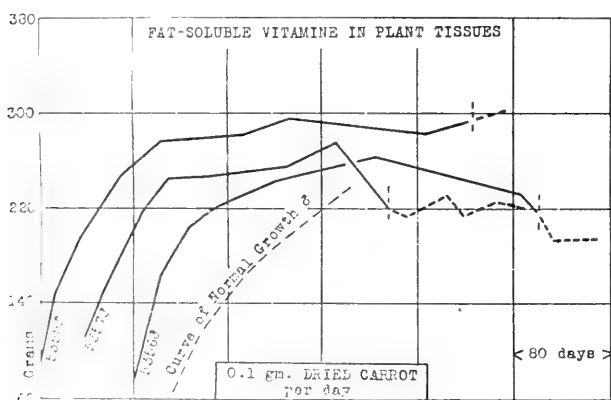

CHART X. Experiments in which 0.1 gm. of dried carrot was fed daily in addition to a diet deficient in fat-soluble vitamine. The interrupted lines indicate the period during which 18 per cent of butter fat was included in the diet.

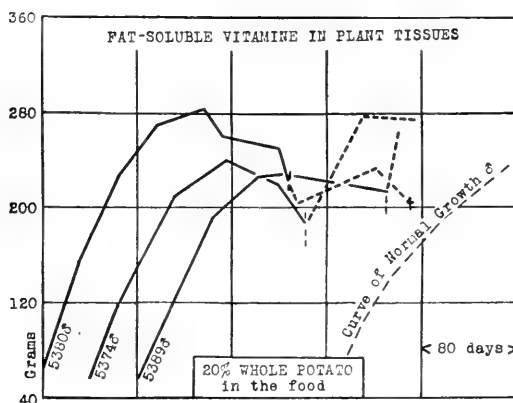

CHART XI. In these experiments the food consisted of

	<i>per cent</i>
Meat residue.....	15
Whole potato.....	20
Salt mixture*.....	4
Starch.....	36
Lard.....	25
Yeast.....	0.2 gm. daily.

* The composition of the salt mixture is given in Osborne, T. B., and Mendel, L. B., *J. Biol. Chem.*, 1919, xxxvii, 572.

The fat-soluble vitamine was furnished by the dried potato until the period represented by the interrupted line, during which 0.5 gm. of butter fat per day was fed in addition. Rat 5380 died of lung disease.



STUDIES OF ACIDOSIS.

XVI. THE TITRATION OF ORGANIC ACIDS IN URINE.

BY DONALD D. VAN SLYKE AND W. W. PALMER.

(From the Hospital of The Rockefeller Institute for Medical Research, and
The Chemical Division of the Department of Medicine, Johns
Hopkins Medical School, Baltimore.)

(Received for publication, February 24, 1920.)

Description of Method.

100 cc. of urine, roughly measured, are thoroughly mixed with 2 gm. of finely powdered calcium hydroxide, allowed to stand about 15 minutes with occasional stirring, and then passed through a dry folded filter. This treatment removes carbonates and phosphates. To 25 cc. of the filtrate in a 125 to 150 cc. test-tube of clear glass¹ one adds 0.5 cc. of 1 per cent phenolphthalein solution, and 0.2 N hydrochloric acid from a burette (amount need not be measured) until the pink color just disappears (pH = approximately 8). 5 cc. of 0.02 per cent tropeolin OO solution are then added. As the indicator solution is added it is thoroughly mixed with the urine by shaking the tube; if this precaution is omitted some of the tropeolin OO may be precipitated. Finally 0.2 N hydrochloric acid is added from the burette until the red color equals that of a standard solution containing 0.6 cc. of 0.2 N HCl, 5 cc. of tropeolin OO solution, and water to a total volume of 60 cc. When the end-point is approached, sufficient water is added to the titrated solution to make its volume equal to that of the 60 cc. standard solution used in a similar tube as a color control.

In comparing the color of the titrated solution with that in the standard, it is convenient during the titration to hold the two

¹ We use the tubes of Pyrex glass made by the manufacturers for urea determinations by the Van Slyke and Cullen technique. The tubes are 30 mm. inner diameter, 200 mm. long, and uniform in size.

tubes side by side between the thumb and fingers, the tube containing the urine being the one held nearer to the tips of the fingers where it can be easily shaken as the 0.2 N acid is run in from the burette.

Sometimes it is desirable to use a similar technique for the phenolphthalein end-point also. In this case a tube of urine filtrate to which no phenolphthalein is added serves as a standard.

We have found that as the final end-point with tropeolin OO is approached comparison of colors is somewhat facilitated by placing the two tubes side by side in a comparator of the form described by Dernby and Avery, although with practice the end-point may be located within 0.1 cc. by merely holding the tubes together as described above.

Calculation.

From the volume of 0.2 N HCl used to titrate from the end-point of phenolphthalein to that of the tropeolin OO, the amount, usually 0.7 cc., is subtracted which is utilized in a similar titration of a control determination in which water is substituted for the urine. The volume of 0.2 N HCl thus corrected represents the approximate organic acid content of the urine sample, plus the creatine and creatinine, and an amount of amino-acids ordinarily negligible.

In order to calculate the results in terms of cc. of 0.1 N organic acid per liter, the figure representing the cc. of 0.2 N HCl used in the titration is multiplied by 80 (by $\frac{1,000}{25} = 40$ in order to transfer figure from 25 cc. to 1,000 cc. of urine, and by 2 to change from 0.2 N to 0.1 N terms).

Correction for Creatinine.—A 0.1 M solution of creatinine (11.32 mg. per cc.) titrates in the above determination as a 0.1 N solution of organic acid. Therefore, in order to correct for the creatinine, the cc. of 0.1 N organic acid per liter calculated from the above titration may be diminished by

$\frac{\text{mg. creatinine per liter urine}}{11.32}$ or by $\frac{\text{mg. creatinine N per liter urine}}{4.2}$.

The simplest way is to subtract the creatinine correction directly from the cc. of 0.2 N acid used in the titration, and mul-

tiply the difference by 80. In this case the correction is $\frac{1}{80}$ as great as the above; *i.e.*, cc. correction =

$$\frac{\text{mg. creatinine per liter urine}}{906} \text{ or } \frac{\text{mg. creatinine N per liter urine}}{336}$$

Example.—

0.2 N HCl used in titration	cc. 7.6
Correction found in blank analysis.....	0.7 cc.
Creatinine correction for 500 mg. creatinine N per	
liter urine. Correction = $\frac{500}{336}$ cc. =	1.2 "
Total correction	<u>1.9 cc.</u>
Corrected titration figure = 7.6 - 1.9.....	5.7
0.1 N organic acid per liter = 80 × 5.7.....	456.0

Tropeolin OO was preferred by us as indicator for the final end-point. In neutral solution it gives nearly the same yellow color as urine, but so much more intense that a water solution of 0.002 N hydrochloric acid with the indicator can be used as a color standard without the use of a comparator. Very dark urines may need greater dilution, but such are not often encountered. Another advantage of this indicator is that its maximum acid color is not reached even at pH 2.7, so that if too much HCl is added in the titration the solution becomes redder than the standard. This particular advantage is possessed in much less degree by the three indicators mentioned below as alternatives.

Other indicators that may be used are methyl orange, tetrabromophenolsulfonephthalein (bromophenol blue, Clark and Lubs), and dimethylaminoazobenzene. To some eyes the color change of one of these dyes may be more readily detected than that of tropeolin OO. The two azo dyes are not much different in color from tropeolin OO, both changing from yellow to red, but the bromophenol blue turns from blue to a clear yellow on acidifying, and affords a very different alternative. To the authors the tropeolin OO end-point appeared the most satisfactory, however.

Theoretical Basis of Method.

The method is based on the following previously known facts:

1. Relatively little strong mineral acid is required to change the hydrogen ion concentration of a water solution from 10^{-8} to 2×10^{-3} if the only electrolytes present are alkali salts of strong acids, such as sulfates and chlorides.

2. If the salt of a weak acid is present, however; the addition of nearly a full molecule of hydrochloric acid for each molecule of such salt is necessary in order to cause the above change in hydrogen ion concentration. The organic acids known to occur in normal and pathological urines, in amounts sufficient to be quantitatively significant in the total acid excretion of the body, belong to the class of weak acids whose salts behave in the above manner.

3. The only mineral acids found in significant amounts in urine which belong to the class of weak acids, and therefore form salts which show the above behavior, are phosphoric and carbonic acids.

4. Very weak bases form salts which behave like those of the weak acids. Creatinine is titrated almost quantitatively in changing the hydrogen ion concentration from 10^{-3} to 2×10^{-3} , and creatine to about 60 per cent. Aside from the traces of amino-acids, these appear to be the only bases of this kind present in considerable amount in human urine.

Effect of the Different Organic Acids of the Urine on the Titration.

The titration figure obtainable by titrating between two hydrogen ion concentrations a solution containing the salt of an acid of a known dissociation constant may be calculated as follows:

From the law of mass action:

$$(1) \text{H}^+ = k \frac{HA}{A'}$$

H^+ = hydrogen ion concentration in terms of normality.

A' = anion of acid.

k = dissociation constant of the acid.

HA = free, undissociated acid.

BA = salt of the acid.

λ = degree of dissociation of the salt into Na and Ac.

When the salt of the acid is present, and dilutions are of the magnitudes used in titrations (0.1 to 0.01 M), the equation becomes practically

$$(2) \quad H^+ = \frac{k}{\lambda} \times \frac{HA}{BA}$$

As λ in the high dilutions encountered approaches unity, it may in approximate calculations be neglected.

Equation 1 may then be expressed as

$$(3) \quad H^+ = k \times \frac{HA}{BA} \text{ or } \frac{HA}{BA} = \frac{H^+}{k}$$

For acetic acid $k = 1.8 \times 10^{-5}$.

When pH equals 8, or $H^+ = 1 \times 10^{-8}$, we therefore have in the case of acetic acid $\frac{HC_2H_3O_2}{BC_2H_3O_2} = \frac{10^{-8}}{1.8 \times 10^{-5}} = \frac{1}{1,800}$. One part in 1,801 parts, or 0.05 per cent, of the acid is free.

When pH = 2.7, $H^+ = 2 \times 10^{-3}$, and we have $\frac{HC_2H_3O_2}{BC_2H_3O_2} = \frac{2 \times 10^{-3}}{1.8 \times 10^{-5}} = \frac{200}{1.8}$.

At a pH of 2.7, therefore, $\frac{200}{201.8}$, or 99.2 per cent, of the acid is free. Changing the hydrogen ion concentration of an acetate solution from the slightly alkaline reaction of 10^{-8} N (or a pH of 8) to the acid reaction of 2×10^{-3} (pH = 2.7) approximately the reaction of 0.002 N HCl) therefore requires an amount of HCl equal in molecular equivalents to 99.15 per cent of the total acetate present.

For the different acids which occur or may occur in human urine, the values in Table I are calculated. The values of the constants are for 25° unless otherwise indicated.

Comparison of the results so calculated with those experimentally obtained in titrating solutions of some of these acids is satisfactory, as shown in Tables III, IV, and VI of the experimental part of this paper. The conclusion seems justified that the titration as carried out estimates certainly over 90 per cent of the organic acids of the urine, and presumably over 95 per cent, since

a higher titration value by 3 or 4 per cent is obtained for those acids excreted as ammonium salts. The data for carbonic and phosphoric acids indicate the necessity for their removal before the organic acids are titrated.

TABLE I.
Calculated Titration Values of Weak Acids of the Urine.

Acids.	Dissociation constant.	Acid free at		Calculated proportion of acid determined by titrating from pH 8 to pH 2.7.
		$H^+ = 10^{-8} N$ pH = 8	$H^+ = 2 \times 10^{-3}$ pH = 2.7	
		<i>per cent</i>	<i>per cent</i>	<i>per cent</i>
<i>Organic.</i>				
Uric*	1.5×10^{-6}	0.5	99.9	99.4
Acetic†	1.8×10^{-5}	0.0	99.2	99.2
β -hydroxybutyric‡	2.0×10^{-5}	0.0	99.0	99.0
Lactic†	1.4×10^{-4}	0.0	93.5	93.5
Acetoacetic‡	1.5×10^{-4}	0.0	93.1	93.1
Citric§	2.0×10^{-4}	0.0	91.0	91.0
Formic*	2.1×10^{-4}	0.0	90.6	90.6
Hippuric†	2.2×10^{-4}	0.0	90.2	90.2
<i>Mineral.</i>				
H(NaHPO ₄)	2.0×10^{-7}	2.5	100	97.5
H(HCO ₃)¶	3.5×10^{-7}	4.2	100	95.8

* His and Paul.

† Ostwald.

‡ Henderson and Spiro.

§ Shown by Amberg and McClure to occur in amounts equivalent to 60 to 70 cc. of 0.1 N acid in a normal 24 hour urine. The titration values for citric acid given in Column 5 are those directly determined by Sørensen. The constant is estimated from them.

|| Sørensen.

¶ Kendall.

Effect of Weak Bases of the Urine on the Titration.

The amount of strong acid required to change the pH of a solution of a weak base from 8 to 2.7 may be calculated from the dissociation constant K_b .

$$K_b = OH' \times \frac{\text{salt of base}}{\text{free base}} = \frac{10^{-14}}{H^+} \times \frac{\text{salt of base}}{\text{free base}}$$

The "salt of base" represents the amount combined with acid. At pH 8, therefore, salt of base, or $\frac{\text{acid combined with base}}{\text{free base}} = K_b \times \frac{10^{-8}}{10^{-14}} = K_b \times 10^6$. At pH 2.7, or $H^+ = 2 \times 10^{-3}$, the ratio is $K_b \times \frac{2 \times 10^{-3}}{10^{-14}} = 2 K_b \times 10^{11}$. The difference between the acid bound by a given base at pH 8 and that bound at pH 2.7 represents the amount required to titrate between the two points. Table II contains a list of the weak bases of the urine, with their constants and the proportion of an equivalent of HCl

TABLE II.
Calculated Titration Values of Organic Bases of the Urine.

Base.	Basic dissociation constant. K_b	Base free at		Proportion estimated by titrating with HCl from $H^+ = 10^{-8}$ to $H^+ = 2 \times 10^{-3}$	
		$H^+ = 10^{-8}$	$H^+ = 2 \times 10^{-3}$	Calculated.	Observed.
		<i>per cent</i>	<i>per cent</i>	<i>per cent</i>	<i>per cent</i>
Urea*.....	0.0015×10^{-11}	100	99.7	0.3	0.2
Creatinine†..	1.81×10^{-11} *	100	24.0	76.0	99
Creatine‡....	3.57×10^{-11} *	100	12.3	87.7	60
Ammonia‡....	1.5×10^{-5} †	6.2	0.0	6.2	5.3-6.0

* Walker and Wood.
 † Measured at 40°, Wood.
 ‡ Noyes, Kato, and Sosman.

required to titrate each from pH 8 to pH 2.7, calculated as above indicated. The constants are from data obtained at 25°, except for creatine and creatinine. In Column 5 results are brought forward from Table V, showing the amounts of HCl bound by the different bases in the titration, as determined experimentally.

Urea is, both by observation and calculation, practically without effect on the results of the titration, even when the urea concentration is at the maximum observed in human urine.

The available data on the K_b of creatine and creatinine do not yield calculated results corresponding so closely with those experimentally obtained as do the data on the other substances requir-

ing consideration. The divergence is perhaps due to the fact that Wood's values for K_b of creatine and creatinine were determined at 40° , while the titration is performed at 20° . It is evident, however, that practically all the creatinine is titrated as organic acid. The amount of this substance excreted varies between 13 and 27 mg. per kilo of body weight per 24 hours (Folin, 1905). The mean, 20 mg., would neutralize 1.8 cc. of 0.1 N acid per kilo or 108 cc. for a 60 kilo individual.

Creatine when present titrates to about 60 per cent as an organic acid; but it is excreted by adults only in conditions involving rapid autolysis of muscle tissue, and would therefore not, as a rule, require consideration.

Ammonia is titrated to the extent of 5 to 6 per cent, but the actual effect of the presence of organic acids as ammonium rather than fixed alkali salts is to make the results of the titration with most of the acids approximate more closely the theoretical values, as shown in Table IV. The ammonium salts of the organic acids titrate 2.3 to 4.6 per cent more completely than the sodium salts, not 6.2 per cent more completely, as would be theoretically expected, and as is approximately realized for the ammonium salts of hydrochloric and sulfuric acids. The observed positive ammonia error is such as to make the results obtained with all but the weakest organic acids approximate more closely to 100 per cent than the results obtained in the absence of ammonia. The tendency of the ammonia error to correct the opposite error in the organic acid titration is enhanced by the fact that ammonia and organic acid excretion tend to run parallel, particularly when acid excretion is abnormally high, as in diabetic acidosis. For the reasons, therefore, that the ammonia correction is not great and is of a nature actually to diminish, as a rule, the other error in the determination, it has seemed not only simpler but better to attempt no correction for it in urine analyses.

Effect of Amino-Acids on the Titration.

Amino-acids if present in large amount would be disturbing factors, as at an H^+ of 2×10^{-3} they bind with their NH_2 groups considerable amounts of acid. Glycocoll, which does not differ much from the other monoamino-acids in this respect, binds

about $\frac{1}{3}$ molecule of HCl at this H^+ . The amount is calculated as follows:

The acid constant for glycocoll is 3.4×10^{-10} , the basic constant 2.9×10^{-12} , as calculated by Winkelblech from conductivity measurements. From the acid constant we have by calculating as above:

-COOH free at $H^+ = 10^{-8} N$	-COOH free at $H^+ = 2 \times 10^{-3} N$	Proportion of COOH group estimated by titration from $H^+ = 10^{-8}$ to $H^+ = 2 \times 10^{-3}$
<i>per cent</i>	<i>per cent</i>	<i>per cent</i>
96.7	100	3.3

The function of the NH_2 group is similarly calculated from the basic constant, $K_b = 2.9 \times 10^{-12} = (OH)' \times \frac{\text{glycine chloride}}{\text{free glycine}}$ or

$$\frac{COOH-CH_2-NH_2}{COOH-CH_2-NH_2 HCl} = \frac{(OH)'}{2.9 \times 10^{-12}} = \frac{10^{-14}}{H^+ \times 2.9 \times 10^{-12}} = \frac{10^{-2}}{H^+ \times 2.9}$$

From these values we calculate:

-NH ₂ free at $H^+ = 10^{-8} N$	-NH ₂ free at $H^+ = 2 \times 10^{-3} N$	Proportion of NH ₂ group estimated by titration with HCl from $H^+ = 10^{-8}$ to $H^+ = 2 \times 10^{-3}$
<i>per cent</i>	<i>per cent</i>	<i>per cent</i>
100	63.3	36.7

The total consumption of HCl by both COOH and NH_2 groups in the titration should be, according to the above calculation, $0.03 + 0.367 = 0.40$ molecule of HCl per 1 molecule of glycine present. The actual amount observed by Sørensen was 0.385 molecule.

The other monoamino-acids apparently bind similar amounts of HCl. The constants for leucine and alanine were determined by Winkelblech as follows: leucine, $K_a = 3.1 \times 10^{-10}$, $K_b = 2.7 \times 10^{-12}$; alanine, $K_a = 9.0 \times 10^{-10}$, $K_b = 3.8 \times 10^{-12}$. According to these, leucine would require in the titration 0.38 molecule of HCl; alanine 0.36, nearly the same as glycocoll. The results in Table VII for the mixture of all the monoamino-acids obtained from casein are in the same neighborhood (44 per cent).

The amino-acid nitrogen constitutes 1 to 2 per cent of the total urinary nitrogen (Van Slyke, 1913-14; Henriques). On a daily excretion of 14 gm. of nitrogen, 2 per cent would indicate 200 cc. of 0.1 M amino-acids. The neutralizing power of such an amount of amino-acids in the titration would be about 80 cc. of 0.1 N hydrochloric acid.

Our knowledge of the nitrogenous constituents of the urine indicates the presence of no weak bases, aside from those discussed, in quantities sufficient to affect markedly the organic acid titration under discussion, and the nitrogenous excretory products have been so thoroughly studied that it is unlikely that any quantitatively important substances with definitely basic properties have been overlooked.

It therefore appears that in titrating the 24 hour urine of an adult of average size for organic acids, as described in this paper, about 100 cc. of the 0.1 N organic acid estimated is in reality due to creatinine and creatine, 80 cc. or less to amino-acids, and the remainder to organic acids.

EXPERIMENTAL.

Titration of Organic Acids in Water Solutions.—A 20 cc. portion of each acid, of approximately 0.1 N concentration, was titrated in a 100 cc. test-tube with either 0.1 N sodium hydroxide or 0.1 N ammonium hydroxide to neutrality with 0.5 cc. of 1 per cent phenolphthalein. 1 cc. of 0.1 per cent tropeolin OO was then added, and the solution titrated back with 0.2 N HCl to pH 2.7, using 0.002 N HCl solution as standard. The results are given in Tables III and IV.

Titration of Weak Bases in Water Solutions.—Solutions of the bases in 25 cc. portions were brought to pH 8 by addition of 0.1 N NaOH or 0.2 N HCl until a barely visible pink color was reached; then tropeolin OO was added and the solution titrated to pH 2.7. The results are given in Table V.

Effect of Concentration of Phenolphthalein on its End-Point in Presence of Ammonium Salts.—The concentration of phenolphthalein to some extent affects the pH at which the pink color is just visible. If there is but little indicator present a greater part of it must be in the colored form to give a perceptible pink

TABLE III.

Titration of Sodium Salts of Organic Acids.

Acid.	(A)	(B)	(C)	(D)	Organic acid theoretically titratable from pH 8 to pH 2.7 (from Table I).
	0.1 N NaOH to neutralize acid to phenolphthalein.	0.2 N HCl to titrate back to pH 2.7 with tropeolin OO.	Average 0.2 N HCl corrected for blank.	Organic acid determined. $\frac{200 (C)}{(A)}$	
	cc.	cc.	cc.	per cent	per cent
Blank.....	0.1	0.50	0.00		
Acetic.....	20.00	10.60	9.95	99.5	99.4
		10.50			
Citric.....	19.86	9.30	8.88	89.4	91.0
		9.35			
Lactic.....	20.28	9.90	9.40	92.7	93.5
		9.90			
Hydrochloric.....	20.00	0.70	0.20	1.0	

TABLE IV.

Titration of Ammonium Salts of Organic Acids.

Acid.	(A)	(B)	(C)	(D)	(E)	Proportion of NH_4 salt theoretically titrated; <i>i. e.</i> , that for acid calculated in Table I + 6.2 per cent for NH_4 present.	Differences between average percentage of Na salt and NH_4 salt titrated.
	0.1 N acid present.	0.1 N NH_4OH to neutralize acid to phenolphthalein at pH 8.	0.2 N HCl to titrate back to pH 2.7.	Average 0.2 N HCl corrected for 0.5 cc. blank.	Proportion of organic acid determined $\frac{200 (D)}{(A)}$		
	cc.	cc.	cc.	cc.	per cent	per cent	per cent
Acetic.....	19.68	20.51	10.70	10.25	104.1	105.6	4.6
	19.68	20.47	10.80				
Citric.....	21.04	21.55	10.30	9.79	93.0	97.2	3.5
	21.04	21.51	10.27				
Lactic.....	20.06	20.96	10.03	9.50	94.7	99.7	2.3
	20.06	20.96	10.03				

than when the total amount of indicator is greater. Consequently the amount of extra alkali required to make a solution of an ammonium salt show pink with phenolphthalein is some-

TABLE V.

Observed Behavior of Weak Bases when Titrated from pH 8 to pH 2.7.

Base.	Amount present in the 25 cc. of solution titrated.		0.2 N HCl required in titrating from pH 8 to pH 7.	Proportion of base titrated.	Proportion of base calculated as titratable from dissociation constant (Table II).
	gm.	cc. 0.2 N	cc.	per cent	per cent
Urea.....	1.000	83.3	0.1	0.12	0.3
Creatine.....	0.200	7.6	4.1	60.0	87.7
Creatinine.....	0.100	4.41	4.32	97.8	76.0
	0.200	8.83	8.80	99.7	
Monoamino-acids from casein.....	0.100	7.37*	3.25	44.2	36.0-40.0 for glycine, leucine, and alanine.
	0.200	14.63	6.37	43.5	
	0.200	14.63	6.29	43.0	
Ammonia (as (NH ₄) ₂ SO ₄).....		12.50	0.67	5.4	6.2
Ammonia (as NH ₄ Cl).....		12.50	0.75	6.0	
		9.82	0.53	5.4	6.2
			0.52	5.3	

* Calculated on a nitrogen content of 10.3 per cent. The preparation was made by hydrolyzing casein with sulfuric acid, precipitating the bases with phosphotungstic acid, and concentrating the filtrate to dryness under reduced pressure after the phosphotungstic and sulfuric acids had been removed.

TABLE VI.

Effect of Phenolphthalein Concentration on End-Point in Presence of Ammonium Salts.

0.05 M (NH ₄) ₂ SO ₄ .	1 per cent phenolphthalein.	0.1 N NaOH to turn pink to phenolphthalein.	0.2 N HCl to change from phenolphthalein end-point to pH 2.7.		Proportion of ammonia titrated from phenolphthalein end-point to pH 2.7
			Uncorrected.	Minus 0.5 cc. for correction.	
cc.	cc.	cc.	cc.	cc.	per cent
25	0.1	0.85	1.42	0.92	7.3
25	0.2	0.65	1.36	0.86	6.9
25	0.5	0.45	1.20	0.70	5.6
25	1.0	0.45	Too cloudy with precipitated phenolphthalein to titrate.		

what dependent on the amount of indicator used. This is shown by the results in Table VI. It is desirable to use in performing the titrations 0.5 cc. of 1 per cent phenolphthalein solution, as directed, rather than the indefinitely measured drop or two which suffices in ordinary titrations.

TABLE VII.
Titration of Organic Acids Added to Urine.

Organic acid added.	0.1 N organic acid added to 100 cc. urine.	0.2 N HCl used in duplicate titrations of 25 cc. urine filtrate.	Average titration figure minus that for urine alone.	0.1 N added organic acid per liter diluted urine.		Proportion of added organic acid determined.
				Found.	Added.	
	cc.	cc.	cc.	cc.	cc.	per cent
Acetic.	0	3.00 3.00				
	25	4.55 4.53	1.54	123	125	98.4
	50	6.20 6.15	3.17	253	250	101.2
	100	9.15 9.10	6.13	490	500	98.0
Lactic.	0	2.87 2.87				
	25	4.25 4.20	1.36	109	117*	93.2
	50	5.50 5.60	2.68	214	236*	90.7
	100	8.30 8.25	5.41	432	472*	91.6

* The 0.1 N lactic acid used in this experiment had the factor 0.945.

Titration of Known Amounts of Organic Acids Added to Urine.—100 cc. portions of a mixed sample of normal urine were mixed with portions of 25, 50, and 100 cc. respectively of acetic or lactic acid. Each mixture was then diluted to 200 cc., and 100 cc. portions were treated as previously described for determination.

TABLE VIII.
Excretion of Organic Acids with Creatinine Correction.
 Data from hospital patients.

Subject	Weight <i>kg.</i>	Condition.	Urine excretion.									
			Period	Volume. <i>cc.</i>	Creatinine N.		0.2 N HCl used in titrating from pH 8 to pH 2.7.		0.1 N organic acid content.		Total.	Per kilo.
					<i>gm.</i>	<i>cc.</i>	Average minus 0.6 cc. for correc- tion for blank.	Un- correct- ed for creati- nine.	Un- correct- ed for creati- nine.	Un- correct- ed for creati- nine.		
Z	60	Myocarditis, decompensation on admission.	<i>hrs.</i>	<i>cc.</i>	<i>gm.</i>	<i>cc.</i>	<i>cc.</i>	<i>cc.</i>	<i>cc.</i>	<i>cc.</i>	<i>cc.</i>	<i>cc.</i>
			12 (day)	658	0.240	57	7.0, 6.9	6.35	334	277		
			12 (night)	946	0.261	62	4.3, 4.1	3.60	272	210		
			24	1,604	0.501	119			606	487	10.5	8.1
O	60	Myocarditis, some decom- pensation.	12 (day)	707	0.223	53	5.1, 5.25	4.57	258	205		
			12 (night)	744	0.216	51	5.0, 5.0	4.40	262	211		
			24	1,451	0.439	104			520	416	8.2	6.9
C	55	Chronic aortic endocarditis.	12 (day)	242	0.141	34	15.1, 15.3	14.60	282	248		
			12 (night)	332	0.195	46	12.8, 12.9	12.25	325	279		
			24	574	0.336	80			607	527	11.0	9.6
D	62	Chronic myocarditis with decompensation.	12 (day)	647	0.226	54	5.6, 5.7	5.05	261	207		
			12 (night)	750	0.196	47	4.4, 4.3	3.75	225	178		
			24	1,397	0.422	101			486	385	8.8	7.0
H	50	Orthostatic albuminuria.	12 (day)	364	0.091	22	5.55, 5.55	4.95	144	122		
			12 (night)	380	0.091	22	5.25, 5.10	4.48	136	114		
			24	744	0.182	44			280	236	5.6	4.7

The results are given in Table VII. The results are essentially the same as those obtained with acetic and lactic acids in pure water solutions.

Organic Acid Excretion by Individuals with Normal Metabolism.

The data given are sufficient only to indicate the usual excretion of organic acids; the possible normal variations, particularly under unusual conditions, may be greater. The figures of Table

TABLE IX.
24 Hour Excretion of Organic Acids by Normal Young Men.

Subject.	Weight.	24 hour urine.			
		Volume.	0.1 N organic acids uncorrected for creatinine.*		Total N.
		cc.	cc.	cc. per kg.	gm.
Ce.....	54.4	1,000	492	9.0	9.3
Dy.....	68.0	1,650	657	9.8	11.5
E.....	68.0	975	583	8.5	11.7
Fr.....	62.1	1,500	531	8.5	13.2
H.....	68.0	1,150	412	6.1	7.8
Sh.....	56.6	1,500	453	8.0	10.0
K.....	68.4	1,000	490	7.2	8.7
Sp.....	57.2	1,400	521	9.1	9.0
Fe.....	82.6	1,100	748	9.1	15.5
Dn.....	87.0	1,300	493	5.7	13.2
Ch.....	56.2	1,100	420	7.5	11.2
K.....	61.2	700	499	8.2	10.0
Ck.....	56.6	1,300	547	9.7	12.1
Average.....				8.2	

* The creatinine correction would reduce the total organic acid figure by about 2 cc. per kilo.

VIII are from afebrile heart patients, with apparently normal metabolism. The day periods are from 6 a.m. to 6 p.m., the night periods from 6 p.m. to 6 a.m. The data of Table IX are from a series of healthy young men. The figures indicate that the usual excretion of organic acids uncorrected for creatinine varies from about 280 to 750 cc. of 0.1 N acid per 24 hours, or from 5.6 to 11 cc. per kilo of body weight. The creatinine correction reduces the figures to 240 to 600 and 4.7 to 9.6 cc. respectively.

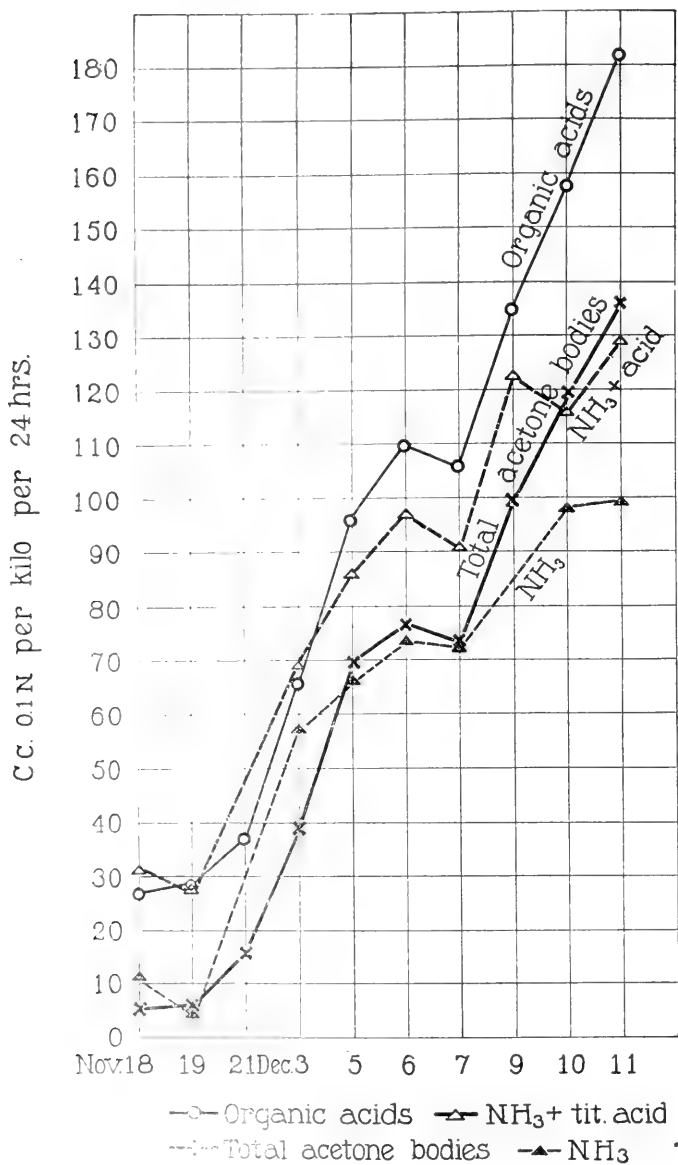

FIG. 1. Excretion in a case of diabetic acidosis.

Comparison of Total Organic Acid Excretion with Acetone Bodies Excretion in Diabetes.

The data given in Fig. 1 were obtained with the only case of diabetic acidosis which we have studied since the organic acid titration method has been available. Although all the data are from one case, they nevertheless represent every stage of diabetic acidosis, from the time when it was slight, with little ketonuria, up to the point of coma, with tremendous ketonuria. The patient was a child of 2 years, weighing 8 kilos. The organic

TABLE X.

Organic Acid Excretion in a Non-Fatal Case of Methyl Alcohol Poisoning.

Date.	CO ₂ bound as bicarbonate by 100 cc. of plasma.	Excretion per liter urine.						
		Creatine.	Creatinine.	Total 0.1 N organic acids.*	0.1 N acetone bodies.	0.1 N lactic acid.	0.1 N formic acid.	Undetermined 0.1 N organic acids.
1919	cc.	gm.	gm.	cc.	cc.	cc.	cc.	cc.
Nov. 24.....	36.4	0.202	0.558	2,042		173	274	1,595
“ 25.....	36.0	0.283	1.000	2,076	481	83		1,512
“ 26.....	86.2	0.535	0.800	1,377	143	30	130	1,074
“ 29.....	76.7	0.300	0.590	262				
Dec. 1.....		0.180	0.538	129				
“ 2.....		0.137	0.557	141				
“ 3.....				220†				
“ 11.....		0.105	0.378	86				
“ 17.....		0.024	0.476	138				
“ 20.....								

* Corrected for creatine and creatinine.

† “ “ “ “ “ “ estimated not determined.

acid figures recorded in Fig. 1 are not corrected for creatine and creatinine, so that they are higher than, though parallel to, the actual organic acid excretion. The “total acetone bodies,” β -hydroxybutyric acid, acetoacetic acid, and acetone were determined by the gravimetric method of Van Slyke (1917), the ammonia as described by Van Slyke and Cullen, and the titratable acid by the method of Folin (1903).

It is evident from the chart that the organic acids of the urine, determined by the technique outlined above, paralleled the ace-

tone body excretion with a high degree of accuracy through all stages of the acidosis, the parallelism being more accurate than that of the ammonia, or even the ammonia plus titratable acid.

It appears that the rise above the normal output in organic acid excretion may be used as an approximate measure of the acetone body excretion in diabetes, the determination of organic acids being as simple as that of ammonia and less influenced by other factors, such, in particular, as alkali administration.

Organic Acid Excretion in Methyl Alcohol Poisoning.—The data of Table X illustrate an acidosis caused by organic acids other than the familiar acetone bodies. The data represent some preliminary work on methyl alcohol poisoning and are inserted here only for their interest in illustrating a hitherto unfamiliar type of acidosis.

SUMMARY.

The organic acids present both free and as salts in urine are estimated by titrating between the hydrogen ion concentrations represented by pH 8 and pH 2.7 respectively, after removal of phosphates and carbonates by means of calcium hydroxide. It appears that the titration represents between 95 and 100 per cent of the organic acids present. It also includes weak bases whose dissociation constants fall within a range in the neighborhood of 10^{-11} , but of this class only creatinine, and at times creatine, appear to be present in significant amounts in human urine.

The average 24 hour excretion of organic acids in thirteen healthy young men was, per kilo of body weight, 8.2 cc. of 0.1 N acid uncorrected for creatinine, or approximately 6 cc. corrected for creatinine; the extreme range was from 5.7 to 9.8 cc. uncorrected for creatinine. There appears to be little difference between day and night periods in rate of organic acid excretion.

Data from cases of methyl alcohol poisoning and diabetes respectively are given as examples of acidosis due to organic acids of different types. In the case of methyl alcohol poisoning part of the total organic acid excretion was due to formic, lactic, and hydroxybutyric acids, but the greater part to acids of unknown nature.

In the case of diabetes, which progressed to coma, the rise in acetone body excretion was accurately paralleled by the rise in

the titrated organic acids. The parallelism was so close as to indicate the probabilities (1) that organic acids other than the acetone bodies are not excreted in significant amounts in diabetic acidosis, and (2) that the easily performed organic acid titration may be used for approximate estimation of the acetone bodies in diabetic urine.

BIBLIOGRAPHY.

- Amberg, S., and McClure, W. B., *Am. J. Physiol.*, 1917, xliv, 453.
Clark, W. M., and Lubs, H. A., *J. Bacteriol.*, 1917, ii, 1.
Dernby, G., and Avery, O. T., *J. Exp. Med.*, 1918, xxviii, 345.
Folin, O., *Am. J. Physiol.*, 1903, ix, 265; 1905, xiii, 66.
Henderson, L. J., and Spiro, K., *J. Biol. Chem.*, 1909, vi, p. xxxix.
Henriques, V., *Z. physiol. Chem.*, 1909, lx, 1.
His, W., and Paul, T., *Z. physiol. Chem.*, 1900-01, xxxi, 1.
Kendall, J., *J. Am. Chem. Soc.*, 1916, xxxviii, 1480.
Noyes, A. A., Kato, Y., and Sosman, R. B., *Z. physik. Chem.*, 1910, lxxiii, 1.
Ostwald, W., *Z. physik. Chem.*, 1889, iii, 173.
Sørensen, S. P. L., *Ergebn. Physiol.*, 1912, xii, 393.
Van Slyke, D. D., *J. Biol. Chem.*, 1913-14, xvi, 125; 1917, xxxii, 455.
Van Slyke, D. D., and Cullen, G. E., *J. Biol. Chem.*, 1914, xix, 211; 1916, xxiv, 117.
Walker, J., and Wood, J. K., *J. Chem. Soc.*, 1903, lxxxiii, 484.
Winkelblech, K., *Z. physik. Chem.*, 1901, xxxvi, 546.
Wood, J. K., *J. Chem. Soc.*, 1903, lxxxiii, 568.



DETERMINATION OF THE FIBRIN, GLOBULIN, AND ALBUMIN NITROGEN OF BLOOD PLASMA.

BY GLENN E. CULLEN AND DONALD D. VAN SLYKE.

(From the Hospital of The Rockefeller Institute for Medical Research.)

(Received for publication, February 24, 1920.)

An investigation into the distribution of the plasma nitrogen, which formed part of a study of the fate of the protein digestion products, led us to develop a technique for the determination of the plasma proteins which gives consistent results and requires no special apparatus. It is based entirely on Kjeldahl determinations, of which the following four are required: (1) total nitrogen of the plasma, (2) fibrin nitrogen, (3) filtrate nitrogen (filtrate, containing albumin and non-protein nitrogen, obtained after precipitating the globulins by half saturation with ammonium sulfate), and (4) non-protein nitrogen.

In the technique finally arrived at the fibrin was precipitated by calcium chloride under definite conditions from plasma containing 0.5 per cent of potassium oxalate, was washed free from other nitrogenous substances, and determined by Kjeldahl.

The globulin was precipitated (together with the fibrin) by the usual half saturation with ammonium sulfate. The nitrogen of the filtrate was determined by Kjeldahl, after removal by distillation of the ammonia of the ammonium sulfate. For the distillation it was found necessary to standardize the conditions accurately in order to make the removal quantitative and at the same time avoid splitting off labile nitrogen from proteins. The non-protein nitrogen was determined on a separate sample of plasma.

The fibrin, globulin, and albumin are calculated as follows:

Fibrin N, determined directly.

Globulin N = Total N - (filtrate N + fibrin N)

Albumin N = Filtrate N - non-protein N

There are two steps in the determination of the albumin and globulin contents of plasma; the first is the separation of the two proteins, or groups of proteins, by precipitation of the globulin with salt, either saturated magnesium sulfate, or half saturated ammonium sulfate. Robertson has reviewed the work on globulin precipitation, and is convinced that ammonium sulfate is the most satisfactory salt for the purpose. We have, therefore, utilized ammonium sulfate precipitation from the start, and since the results have been uniformly consistent have not experimented with other globulin precipitants.

The second step is the determination of the proteins after they have been separated. By different authors this has been done by weighing, by nitrogen determination after dialysis to remove ammonium salts, by the nephelometric method, or by the use of the refractive indices of the proteins as developed by Reiss and by Robertson. The errors inherent in washing and weighing the globulin precipitate are too great to allow accurate results. With nephelometric determinations we have not been able to obtain the desirable degree of accuracy, and a proper refractometer was not available at the time the work was done. We consequently were led to develop a technique in which all the final determinations were made by the Kjeldahl method.

Description of Methods.

Fibrin Determination.

To 5 cc. of plasma, from blood to which 0.5 per cent of potassium oxalate has been added, add 150 cc. of 0.8 per cent NaCl and 5 cc. of a calcium chloride solution containing 2.5 gm. of anhydrous CaCl_2 per 100 cc. Allow complete coagulation to occur (10 to 15 minutes) and filter through filter paper. Wash with 0.8 per cent NaCl five times, allowing each washing to remain in contact with fibrin for 10 minutes by closing the outlet of the funnel for that period. Transfer filter paper containing fibrin clot to Kjeldahl flask and add 20 cc. of sulfuric acid, 12 gm. of potassium sulfate, and a crystal of copper sulfate, and determine nitrogen in the usual manner.

Albumin Determination.

Precipitation of Globulin.—To 5 cc. of plasma add 20 cc. of water and 25 cc. of saturated ammonium sulfate solution, allow to stand over night, and filter through a dry filter.

Removal of Sulfate Ammonia.—Place 20 cc. of filtrate (= 2 cc. of plasma) in a 500 cc. Kjeldahl flask, add 300 cc. of 50 per cent alcohol, 3 gm. of MgO (Merek's reagent), and 1 cc. of white mineral oil. Distill until distillate gives a negative test with red litmus paper.

Digestion of Residue.—To residue add 25 cc. of concentrated H_2SO_4 , 5 gm. of K_2SO_4 (addition of more, with magnesium sulfate present, would cause bumping), and a small crystal of copper sulfate. Digest to a light brown color. Then wash flask down with a few cc. of water and add 10 cc. more of H_2SO_4 . Continue digestion over a low flame for about 3 hours. Distill into $N/14$ HCl in the usual manner. Calculate nitrogen as "filtrate nitrogen."

Albumin nitrogen = Filtrate nitrogen - non-protein nitrogen

Total Plasma Nitrogen Determination.

The total nitrogen determinations are carried out on 2 cc. of plasma by the regular Gunning-Kjeldahl method, using 20 cc. of concentrated H_2SO_4 , 12 gm. of K_2SO_4 , about 0.2 gm. of copper sulfate, and digesting 3 hours after clearing.

Non-Protein Nitrogen Determination.

The non-protein nitrogen is determined in the filtrate obtained by precipitation of the plasma protein in 9 volumes of 2.5 per cent trichloroacetic acid (Greenwald, 1915). A 50 or 100 cc. measuring flask is half filled with the trichloroacetic acid solution, to which 5 or 10 cc. of plasma are added. The flask is then filled to the mark with the trichloroacetic acid solution, and the contents are thoroughly mixed. After standing 1 hour the contents of the flask are filtered through a dry filter, the filtrate is measured, and transferred to a Kjeldahl flask. 20 cc. of H_2SO_4 , 12 gm. of K_2SO_4 , and a crystal of copper sulfate are added, and the nitrogen is determined in the usual manner.

On the basis of Greenwald's recent results (1918), it would seem slightly preferable to use 5 per cent rather than 2.5 per cent trichloroacetic acid. The differences introduced are so minute, however, that for the determination of the proteins they are not significant.

Correction for Reagents.

It is necessary to determine the corrections for all the reagents. Our blanks averaged 0.46 cc. of $N/14$ HCl, a rather high value, but one constant for the given lot of reagents.

EXPERIMENTAL.

Determination of Filtrate Nitrogen.

In order to determine the albumin and non-protein plasma nitrogen in the filtrate from the globulin, it was necessary to find conditions for distilling off the ammonia of the ammonium sulfate without splitting off ammonia from any of the plasma proteins. In order to avoid such decomposition it was desirable to use in the distillation as weak an alkali as possible. Magnesium oxide, in former work on protein analyses (Van Slyke), had been found to be as mild an alkali as could be successfully used to drive off ammonia, and it proved to be suitable in this case also when used together with alcohol. It was found that the physical properties of the oxide were of importance. Tremendous bumping, resulting in broken flasks, took place with all but one brand of MgO. When Merek's reagent oxide was used with the addition of 1 cc. of white mineral oil, and the flask with its contents was frequently shaken until the boiling commenced, the distillation proceeded smoothly and without bumping.

Distillation with Water.—2 cc. of plasma and 10 cc. of saturated ammonium sulfate solution were diluted with 200 cc. of water in a 500 cc. Kjeldahl flask and an excess of magnesium oxide, 2 to 3 gm., was added (at 20°C. a half saturated ammonium sulfate solution contains 38 gm. per 100 cc. of the solution; 10 cc. would then require 1.7 gm. of MgO). The water and ammonia were distilled off. The nitrogen in the residue was then determined as outlined below.

In each case distillation was continued until moistened red litmus paper held in the distillate no longer turned blue at once. Actual cessation of ammonia distillation did not occur, because of a slight but continuous splitting off of ammonia from the proteins. Consequently if the litmus paper was held in the distillate for 2 minutes, an alkaline reaction could be obtained at any stage of the distillation. The end-point was therefore taken as the stage at which the distillate failed to turn litmus at once.

It was found that frequently the ammonia was not completely removed by distilling nearly to dryness once; it was necessary

TABLE I.

Albumin Determination. Removal of Ammonium Sulfate Nitrogen by Water Distillation in Presence of Magnesium Oxide.

2 cc. plasma + 10 cc. saturated $(\text{NH}_4)_2 \text{SO}_4$ solution. Total nitrogen of plasma controlled on 2 cc. duplicates.

Method of concentration.	MgO	H ₂ O used.	Final volume.	Proportion of plasma nitrogen recovered.
	gm.	cc.	cc.	per cent
Distillation from Kjeldahl flask.	2.3	400 in two portions.	50	98.3
“ “ “ “	2.3	400 “ “ “	50	97.8
“ “ “ “	2.3	400 “ “ “	50	96.0
“ “ “ “	2.3	400 “ “ “	50	97.8
“ “ “ “	2.3	400 “ “ “	50	96.0
“ “ “ “	2.3	400 “ “ “	50	96.0
“ “ “ “	2.3	400 “ “ “	50	93.0
“ “ “ “	2.3	400 “ “ “	50	94.0
“ “ “ “	2.3	400 “ “ “	50	92.0

to add a second 200 cc. of water and distill again. With two distillations all the sulfate ammonia was removed, but with it from 2 to 8 per cent of the plasma nitrogen was lost, apparently as the result of ammoniacal decomposition of the plasma proteins (Table I). Regulation of the rate of distillation, of the final volume, *etc.*, all failed to prevent this loss.

Distillation with Alcohol.—In attempting to reduce both time and temperature of distillation, a mixture of alcohol and water was substituted for the water. A few of the results are given in Table II.

It is evident that with the use of 50 per cent alcohol, 99 per cent of the plasma nitrogen can be consistently recovered. One distillation only, taking 30 to 45 minutes, is required to drive off all ammonia. In studying the distribution of the plasma proteins following digestion, the method was tested several times on plasma from each of a dozen dogs. Between 99.8 and 98.5 per cent of the plasma nitrogen was invariably recovered.

TABLE II.

Albumin Determination. Removal of Ammonium Sulfate Nitrogen by Distillation in Presence of MgO and Alcohol.

2 cc. plasma + 10 cc. saturated $(\text{NH}_4)_2\text{SO}_4$ solution.

MgO	H ₂ O	95 per cent alcohol.	Final volume.	Proportion of plasma nitrogen recovered.
gm.	cc.	cc.	cc.	per cent
3.5	150	150	25	99.6
3.0	150	150	25	99.2
2.5	150	150	15	99.6
3.0	150	150	Dry.	97.9
3.0	150	150	25	99.0
3.0	150	150	25	99.6
3.0	150	150	25	99.1
3.0	150	150	25	99.2
3.0	150	150	25	99.0

Fibrin Determination.

Dilution of Plasma.—If calcium is added to undiluted oxalated plasma the entire mass jellies. If, however, the plasma is diluted with isotonic NaCl solution, the fibrin forms as a delicate membrane which contracts upon shaking or stirring to a small compact mass. Moreover, if the plasma is diluted ten- to thirtyfold the quantity of nitrogen in the solution adhering to the small clot is presumably much smaller than if the fibrin is whipped from undiluted plasma. In order to ascertain the best dilution, oxalated plasma was mixed with varying amounts of isotonic NaCl solution, which, to prevent globulin precipitation, was used instead of water. Preliminary experiments had shown that at least 2 molecules of calcium chloride should be added for each molecule of potassium oxalate present in the plasma.

The time required to complete the formation of the fibrin clot and the appearance of the clot were noted. Typical results are shown in Table III.

The clots formed when the plasma was diluted with 10 volumes of salt solution did not appear so satisfactory as those formed with either 20 or 30 volumes. There was no choice between

TABLE III.

Determination of Dilution Most Suitable for Plasma Fibrin Coagulation.

1 cc. plasma diluted as indicated.

Plasma.		0.8 per cent NaCl.	Calcium added for recalcification.			Time required for complete clotting.	Coagulation observed.
No.	Oxalate concentration.		CaCl ₂ solution.		Oxalate equivalent.		
	<i>per cent</i>	<i>cc.</i>	<i>per cent</i>	<i>cc.</i>		<i>min.</i>	
1	0.25	5	2.5	1	15		Not complete Good. " "
	0.25	10	2.5	1	15	9	
	0.25	20	2.5	1	15	5	
	0.25	30	2.5	1	15	6	
	0.25	40	2.5	1	15	7	
2	0.25	10	0.17	2	2	8.5	Good. Good. Good. Good.
	0.25	20	0.17	2	2	8.5	
	0.25	30	0.17	2	2	9	
	0.25	10	0.17	4	4	7	
	0.25	20	0.17	4	4	9.5	
	0.25	30	0.17	4	4	9	
	0.25	10	2.5	1	15	7	
	0.25	20	2.5	1	15	8.5	
0.25	30	2.5	1	15	9		
1	1.0	10	0.48	5	15	7	
	1.0	20	0.48	5	15	7	
	1.0	30	0.48	5	15	7	
	1.0	40	0.48	5	15	21	

20 and 30 volumes, but with 40 volumes the clot appeared less satisfactory, and the time required for its formation was greater than with 20 or 30 volumes. The use of either 20 or 30 volumes of 0.8 per cent salt solution was, therefore, adopted.

Permissible Range of Calcium Chloride Concentration.—In order to determine the range of calcium concentration over which

satisfactory fibrin clot formation can occur, varying amounts of calcium chloride were added to a series of tubes each containing 1 cc. of plasma and 20 cc. of salt solution.

It is evident from Table IV that fibrin formation is complete if calcium is added in from two to twenty equivalents of the oxalate present. Allowing for a maximum oxalate concentration of 1 per cent, each cc. of plasma would require for an equivalent amount

TABLE IV.

Influence of Concentration of Calcium Chloride on Fibrin Clot Formation.

1 cc. plasma + 20 cc. 0.8 per cent NaCl recalcified in the presence of varying amounts of oxalate.

Oxalate concentration.	Calcium added for recalcification.			Time required for complete clotting.
	CaCl ₂ solution.		Oxalate equivalent.	
<i>per cent</i>	<i>per cent</i>	<i>cc.</i>		<i>min.</i>
1	0.5	0.5	0.37	∞
1	0.5	1	0.75	∞
1	0.5	2	1.5	9.0
1	0.5	4	3.0	5.0
1	2.5	1	3.7	5.5
1	2.5	2	7.5	6.5
1	2.5	4	15.0	11.0
0.25	2.5	0.25	3.7	7.0
0.25	2.5	0.5	7.5	7.5
0.25	2.5	1.0	15.0	7.5
0.25	2.5	1.5	22.5	9.0
0.25	2.5	2.0	30.0	>15
0.25	0.17	0.5	0.5	>30
0.25	0.17	1	1	>30
0.25	0.17	2	2	9
0.25	0.17	4	4	9

of calcium 0.2 cc. of 2.5 per cent CaCl₂. 1 cc. of 2.5 per cent CaCl₂ solution would then contain five equivalents. If the oxalate concentration were 0.25 per cent, which is just sufficient to prevent coagulation, the use of an equal volume of 2.5 per cent CaCl₂ would mean that twenty equivalents of calcium had been used. This amount of CaCl₂ does not interfere with the clot formation, and provides for all probable concentrations of oxalate.

Collection, Washing, and Nitrogen Determination of the Fibrin.—It has been our experience that the determination of the nitrogen content of a protein is a more accurate measure of its mass than the method of drying to constant weight. The errors due to adherent substances or to partial decomposition during drying are thus eliminated. After testing varying conditions for the Kjeldahl digestion the following procedure was adopted. The filter paper with the washed fibrin clot was transferred to a 500 cc. Kjeldahl flask. 20 cc. of concentrated sulfuric acid, 12 gm. of potassium sulfate, and a small crystal of copper sulfate were added, and the mixture was digested for 3 hours after the clearing of the solution.

TABLE V.

Quantitative Test of Fibrin Method.

5 cc. plasma, 0.25 oxalate; 0.8 per cent NaCl solution, CaCl₂, and washing as indicated. Nitrogen determined by Kjeldahl method.

H ₂ O	0.8 per cent NaCl added.	Calcium added for recalcification.			Washed.	Fibrin N. per 100 cc.
		CaCl ₂ solution.		Oxalate equivalent.		
cc.	cc.	per cent	cc.			gm.
	100	2.5	5	15	0.8 per cent NaCl five times.	0.046
	150	2.5	5	15	0.8 " " " " "	0.044
	150	2.5	10	32	0.8 " " " " "	0.044
	150	1.0	5	6	0.8 " " " " "	0.042
	150	1.0	10	12	0.8 " " " " "	0.044
	50	1.0	10	12	0.8 " " " " "	0.044
	150	1.0	10	12	H ₂ O till chloride-free.	0.042
	50	1.0	10	12	" " " " "	0.048
100		1.0	10	12	" " " " "	0.048

The fibrin clot was collected by filtration. In order to be sure that all traces of soluble proteins were removed from the clot, experiments were done to determine whether or not washing with NaCl only or with water was more satisfactory. Each washing was allowed to remain in contact with the clot for several minutes to allow time for diffusion. This was done by closing the outlet at the bottom of the funnel stem for the desired time.

It is evident from Tables V and VI that five washings with salt solution or washing with water until the filtrate is salt-free yields consistent results.

TABLE VI.

Test of Different Methods of Washing Fibrin Clot.

5 cc. plasma diluted to 150 cc. with 0.8 per cent NaCl, 5 cc. 2.5 per cent CaCl₂ solution added. Fibrin washed on filter paper as indicated. Nitrogen determined by Kjeldahl method.

0.8 per cent NaCl.	H ₂ O	Each washing allowed to stand.	Fibrin N per 100 cc.
			gm.
Five times.		10	0.077
" "		10	0.075
" "		10	0.073
" "		15	0.075
" "		30	0.079
Five times.		30	0.075
" "		30	0.075
Three "		30	0.083
Four "		30	0.075
" "		60	0.071

TABLE VII.

Influence of Excess of Decalcifying Salts on the Concentration of Total Nitrogen and Fibrin in Plasma.

Blood was drawn mixed with sufficient oxalate to prevent clotting. Salt was then added to portions of blood to concentration indicated. Blood centrifuged and plasma analyzed in usual way.

Sample No.	Concentration of oxalate.	Total N per 100 cc.	Fibrin N per 100 cc.
	per cent	gm.	gm.
1	0.1	1.16	0.024
	1.1	1.018	0.029
	2.0	0.958	0.025
2	0.5	1.0	0.049
	1.0	0.929	0.051
	2.0	0.874	0.051
3	0.5	0.898	0.051
	1.0	0.862	0.047
	2.0	0.746	
To plasma from 0.5 per cent oxalated blood (Sample 3) oxalate was added to make 2 and 5 per cent.	2.0	0.887	
	5.0	0.887	

Influence of the Oxalate Concentration of the Plasma.—It was found (Table VII) that the amount of oxalate present in the plasma had no effect on the fibrin, but that variation in the concentration of oxalate in the whole blood before centrifugation has a considerable effect on the total nitrogen content of the plasma, presumably because of effects on the water distribution between cells and plasma. Consequently in order to obtain accurately comparable results on different plasmas a constant concentration of oxalate must be used. We add 0.5 gm. of potassium oxalate per 100 cc. of whole blood.

SUMMARY.

Methods are described for separation of the fibrin, globulin, and albumin of blood plasma in such a manner that they may be determined by the Kjeldahl method.

BIBLIOGRAPHY.

- Greenwald, I., *J. Biol. Chem.*, 1915, xxi, 61; 1918, xxxiv, 97.
Reiss, E., *Beitr. chem. Physiol. u. Path.*, 1903, iv, 150.
Robertson, T. B., *J. Biol. Chem.*, 1912, xi, 179; also *Physical chemistry of the proteins*, New York, 1918.
Van Slyke, D. D., *J. Biol. Chem.*, 1912, xii, 295.

STUDIES OF VARIATIONS IN THE CHEMICAL COMPOSITION OF HUMAN BLOOD.

By FREDERICK S. HAMMETT.

(From the Laboratory of the Pennsylvania Hospital, Department for Mental and Nervous Diseases, Philadelphia.)

(Received for publication, January 27, 1920.)

CONTENTS.

Introduction.....	599
Methods.....	600
Individual variability.....	602
Group variability.....	606
Influence of time of withdrawal of blood on its composition.....	609
Nitrogen distribution in the blood.....	610
Summary.....	613
Bibliography.....	615

INTRODUCTION.

Studies on the chemical composition of human blood have been largely confined to the determination of the nature and the amounts of the constituents. The more exact methods of Folin (1, 2) and his collaborators have placed in the hands of the investigator a means of studying the changes taking place in the concentration of the various blood components in health and disease. The early results have been amplified and extended so that today the literature contains many reports of the normal limits within which these substances fluctuate. Probably the most complete survey of the chemical and physical composition of human blood is that published by Gettler and Baker (3). Studies which have been made of the relations between the determinable nitrogenous constituents have been limited in their applicability by the omission of one or more of the soluble nitrogenous components from direct estimation. The extensive studies of Bang (4) and Feigl (5) are more recent examples of this failure to consider the individual components.

600 Nitrogenous Constituents of Human Blood

In view of this lack of tangible data a study is here made of the relative variability and reciprocal relations of the soluble nitrogenous compounds more commonly associated with protein metabolism together with the total nitrogen and the sugar of the blood. The data naturally divide under four headings. There is the study of the relative variability of the blood components for the individual; the discussion of the relative variability of these constituents in a group series of bloods; the influence of the time of withdrawal of the blood on its composition; and lastly, the study of the changes in the amounts, distribution, and interrelations of the nitrogen of the various constituents which accompany the changes in the level of the total non-protein nitrogen itself.

Methods.

The individuals from whom the bloods were taken for these studies were patients and nurses at this hospital. No subject was accepted for study who presented evidence of metabolic disorder. The use of patients suffering from one sort or another of mental disorder for a study of this nature seems to be allowable on the basis of the early findings of Folin (6) that the urinary nitrogenous constituents of such patients are within normal limits. Tracy and Clark (7), however, express the opinion that certain individuals of this type may present some alterations in creatinine excretion due to their relative muscular inactivity.

No quantitative dietary regulation was attempted since the general uniformity of the hospital diet from a qualitative point of view would tend towards the establishment of a qualitative uniformity in its manner of utilization, the degree of which would be dependent ultimately upon the amount of and the individual reaction to the ingested foodstuffs. Any regular variation tendencies that might be found would be all the more indicative of an underlying constancy of metabolic relation. The limits to which data from such material can be used are well recognized and the interpretations that are read into the results are consequently subject to similar conditions and are to be taken with that understanding.

Since the investigations of Raiziss, Dubin, and Ringer (8) indirectly, and of Addis and Watanabe (9), Gettler and Baker (3), and others directly support the contention that a rigid level of content of blood constituents is obtainable only with difficulty and after a considerable period of regulated food intake, the samples of blood to be analyzed were taken at the uniform hour of 11 a.m., $3\frac{1}{2}$ hours after the first meal, unless otherwise noted. The blood from any single individual was not taken more often than once in 7 days.

The blood was drawn into a Record syringe containing a small amount of potassium oxalate (1). Care was taken to avoid the sucking in of air, and after filling the syringe the point of the needle was plunged under paraffin oil (10), and 2 cc. of blood were expressed. This part of the sample was used for the determination of the alkaline reserve. The remainder of the blood, about 25 to 30 cc. in amount, was transferred to a small bottle containing oxalate crystals and brought immediately to the laboratory. From this sample 1 cc. was removed with an Ostwald pipette and diluted to 50 cc. with distilled water in a graduated flask. 1 cc. portions of the diluted blood were used for the estimation of the total nitrogen according to the method of Folin and Farmer (11). The residual sample was freed from protein by the procedure of Folin and Wu (12), and the non-protein nitrogen, urea nitrogen, creatinine, creatine, uric acid, and sugar were determined by following the methods outlined in their publication. The standard for the creatinine and creatine determinations was pure creatinine prepared by the method of Benedict (13). The picric acid was purified according to Folin and Doisy (14), solutions of this substance being made up fresh each day. In the aerations the turpentine and resin mixture of Kendall (15) was used as a foam breaker with good results. The only difficulty that presents itself with this reagent was that there remains a considerable residuum of resinous matter in the test-tubes which must be removed after each total nitrogen determination by boiling with $\text{CuSO}_4\text{-K}_2\text{SO}_4\text{-H}_2\text{SO}_4$ mixture. The amino-acid nitrogen was determined in aliquots of the filtrate after evaporation to a small volume with a few drops of carbonate as indicated by Whipple and Van Slyke (16), the analysis being made with the micro apparatus and technique of the latter investigator (17).

Preliminary tests showed that the variations in the results obtained in these filtrates from results obtained in the filtrates from other reliable methods of precipitation were negligible. Repeated tests failed to show any marked interfering factor arising from the action of the nitrous acid on the urea during the analysis as carried out and hence no correction was made for this substance. The residual or rest nitrogen was obtained as the difference between the sum of the nitrogen found as urea, creatinine, creatine, uric acid, and amino-acids and that of the total non-protein nitrogen. Separate ammonia determinations were not made. The extreme lability of this substance (18), the observations of Gad-Andersen indicating that the increase in blood ammonia on standing may be due to a concurrent urea decomposition (19), and the confirmation of Folin's (20) statement that the amounts of ammonia in these filtrates are so small as to be negligible, made any attempts at its determination here superfluous.

Individual Variability.

Table I presents the figures for the amounts and the average deviations of each constituent determined in the bloods of nine individuals. The specimens from each individual were taken at weekly intervals $3\frac{1}{2}$ hours after the morning meal, with the exception that Sets 7', 8', and 9' were taken before breakfast. These latter sets are from the same subjects as are the figures in Sets 7, 8, and 9. The results are representative of amounts of nitrogen per 100 cc. of blood.

It will be noted that while the composition of the blood in any given individual varies from week to week the level of the concentrations of the various substances is individual in character.

In Table II are given the sums of the average deviations for each individual. The marked differences observed are taken as meaning differences in metabolic stability.

In order to study the relative variability of the constituents the average deviations were in the case of each blood arranged in the order of increasing value. Since nine constituents are reported there are nine possible places on the scale of ascending variability into which any one of the constituents might fall. Table III gives for each constituent its relative place in the scale of increasing variability in terms of the per cent incidence.

TABLE I.
Individual Variations in Blood Composition.

Set No.	Total N.	Non-protein N.	Urea N.	Creatinine N.	Creatinine N.	Uric acid N.	Amino-acid N.	Rest N.	Sugar.
	<i>gm.</i>	<i>mg.</i>	<i>mg.</i>	<i>mg.</i>	<i>mg.</i>	<i>mg.</i>	<i>mg.</i>	<i>mg.</i>	<i>mg.</i>
1	2.6	38.1	21.4	0.48	1.16	0.93	4.1	10.0	88
	3.1	30.6	12.5	0.48	1.35	1.10	6.7	8.5	109
	2.32	30.6	10.6	0.52	1.31	0.77	5.6	11.8	106
	3.06	36.3	17.5	0.44	1.22	1.03	4.8	11.3	105
	3.21	37.8	18.2	0.48	1.15	0.83	4.7	12.4	100
	2.65	31.5	17.6	0.44	1.15	0.70	5.0	6.4	100
	Average... " deviation	2.83 10.6	34.1 9.6	16.3 19.4	0.47 5.0	1.22 5.8	0.89 14.3	5.1 12.8	10.1 17.5
2	2.75	39.0	20.1	0.48	1.22	0.90	4.3	12.0	90
	2.22	39.9	15.1	0.52	1.47	0.70	5.3	16.8	116
	2.91	33.6	17.7	0.44	0.96	0.73	5.7	8.1	92
	2.56	34.8	15.0	0.48	1.52	0.70	4.6	12.5	101
	2.71	33.0	15.4	0.48	1.19	0.70	5.4	9.8	96
	2.80	39.0	21.1	0.48	1.22	0.96	4.5	10.7	97
	Average... " deviation	2.66 6.7	36.5 7.5	17.4 13.5	0.48 2.8	1.26 12.2	0.78 12.7	4.9 10.2	11.6 18.3
3	2.67	43.8	25.1	0.41	1.35	0.77	4.9	11.3	135
	3.09	32.4	15.5	0.48	1.41	0.53	4.8	10.1	120
	2.94	42.9	24.8	0.44	1.22	0.73	6.2	9.5	113
	3.57	41.4	19.5	0.48	1.44	0.70	6.3	13.0	134
Average... " deviation	3.09 8.5	40.1 9.5	21.1 18.0	0.45 6.1	1.35 5.1	0.68 11.3	5.5 12.7	11.0 10.6	125 7.1
4	3.52	43.3	20.1	0.44	1.25	0.70	4.5	16.2	90
	2.61	38.7	21.2	0.52	1.47	0.73	3.4	11.4	120
	2.61	34.8	15.5	0.41	1.99	0.85	3.6	13.5	87
	2.65	38.4	18.5	0.44	1.78	0.87	3.9	12.9	115
	2.71	37.5	15.9	0.48	1.41	0.83	4.8	14.1	97
	2.80	36.6	22.0	0.41	1.44	0.80	5.4	6.6	100
	Average... " deviation	2.82 8.4	38.2 4.8	18.9 11.8	0.45 7.4	1.39 13.0	0.80 6.6	4.3 14.7	12.4 18.7

604 Nitrogenous Constituents of Human Blood

TABLE I—Continued.

Set No.	Total N.	Non-protein N.	Urea N.	Creatinine N.	Creatine N.	Uric acid N.	Amino-acid N.	Rest N.	Sugar.
	gm.	mg.	mg.	mg.	mg.	mg.	mg.	mg.	mg.
5	3.24	46.7	13.1	0.41	1.70	0.93	4.6	26.0	105
	2.61	35.4	18.1	0.44	1.35	0.90	5.0	9.3	112
	3.00	31.5	17.7	0.48	1.31	1.07	5.1	8.8	104
	3.00	36.6	13.9	0.44	1.25	1.27	5.7	14.0	126
Average...	2.97	38.3	15.7	0.44	1.40	1.04	5.1	14.5	112
" deviation	5.7	10.9	11.0	3.9	10.5	12.3	5.9	39.5	6.4
6	3.26	40.0	22.6	0.43	1.71	0.57	5.9	8.8	125
	3.30	31.5	17.7	0.40	1.45	0.61	5.6	8.8	122
	2.73	37.3	19.2	0.44	1.44	0.56	6.0	9.6	166
	2.73	33.7	16.7	0.48	1.48	0.73	6.6	7.8	145
Average...	3.00	36.4	19.0	0.44	1.52	0.62	6.0	8.8	139
" deviation	9.2	6.3	9.9	5.1	6.2	9.8	4.8	5.0	11.5
7	3.03	53.6	39.7	0.57	1.42	1.98	6.7	9.4	108
	3.03	55.6	39.0	0.56	1.50	2.14	6.8	10.2	99
	3.00	52.6	37.5	0.62	1.40	2.14	6.4	8.6	92
	3.09	51.5	31.9	0.56	1.27	2.45	6.1	22.4	99
Average...	3.04	54.6	37.0	0.58	1.40	2.18	6.4	12.6	99
" deviation	0.90	1.8	6.9	3.8	4.5	6.3	3.9	38.8	4.0
8	3.33	33.7	16.6	0.46	1.20	0.79	6.1	8.6	89
	3.12	33.1	15.9	0.48	1.42	0.79	3.6	11.0	133
	3.30	34.6	13.1	0.43	1.19	0.70	5.3	13.9	96
	3.42	38.7	16.9	0.50	1.25	0.96	5.0	14.1	115
Average...	3.29	35.0	15.6	0.47	1.26	0.81	5.0	11.9	108
" deviation	2.6	5.2	8.0	4.8	6.0	9.3	13.9	17.7	14.8
9	3.66	35.9	23.6	0.54	1.49	0.69	6.9	3.7	114
	3.15	45.5	23.8	0.54	1.49	0.82	6.3	12.5	106
	3.00	40.0	22.1	0.53	1.30	0.99	5.3	9.8	103
	2.88	37.3	21.3	0.53	1.38	0.80	5.7	7.6	111
Average...	3.17	39.7	22.7	0.53	1.41	0.82	5.8	8.4	108
" deviation	7.7	7.6	4.3	1.0	5.2	9.8	5.0	32.8	3.7

TABLE I—*Concluded.*

Set No.	Total N.	Non-protein N.	Urea N.	Creatinine N.	Creatine N.	Uric acid N.	Amino-acid N.	Rest N.	Sugar.
	<i>gm.</i>	<i>mg.</i>	<i>mg.</i>	<i>mg.</i>	<i>mg.</i>	<i>mg.</i>	<i>mg.</i>	<i>mg.</i>	<i>mg.</i>
7'	2.88	56.6	33.0	0.55	1.48	2.03	5.9	13.7	119
	3.30	52.2	31.9	0.52	1.51	2.00	5.6	10.6	116
	2.97	50.9	30.0	0.62	1.35	2.28	6.5	10.1	87
	3.00	54.5	30.6	0.53	1.31	1.74	5.6	14.7	118
	Average...	3.04	53.5	31.4	0.55	1.41	2.01	5.8	12.3
" deviation	4.3	3.7	3.3	6.8	5.8	7.2	2.4	15.5	10.3
8'	3.30	32.8	14.2	0.46	1.28	0.78	5.0	11.0	100
	3.45	31.4	16.7	0.46	1.40	0.73	5.1	7.1	105
	3.24	37.1	14.2	0.48	1.21	0.66	5.6	14.9	104
	3.16	36.2	14.8	0.48	1.31	0.67	5.4	13.6	108
Average...	3.29	34.4	15.0	0.47	1.30	0.71	5.3	11.7	103
" deviation	2.6	6.6	5.9	2.0	2.9	6.3	4.2	14.6	2.5
9'	3.33	36.2	19.8	0.49	1.20	0.76	4.8	9.1	138
	3.00	32.9	18.9	0.45	1.46	0.58	4.9	7.5	126
	3.33	36.7	22.6	0.48	1.46	0.51	6.3	5.1	97
	3.00	30.6	19.1	0.48	1.31	0.57	5.7	3.4	96
Average...	3.16	34.1	20.1	0.47	1.36	0.60	5.4	6.2	114
" deviation	5.2	6.8	6.2	3.1	7.5	12.4	10.6	32.2	15.5

TABLE II.

Relative Metabolic Stability of Different Individuals as Calculated from Average Deviations Observed in Table I.

Set No.....	1	2	3	4	5	6	7	8	9	7'	8'	9'
Relative stability.....	100	91	89	96	109	68	71	82	77	59	48	101

Table III reveals a quite consistent tendency to increasing variability of the constituents in the order given, the scatterings that occur being due in large part to individual differences in nature of metabolic stability.

Group Variability.

We turn now from the consideration of the variations in the constituents of the blood of an individual to a study of the variations within a group of bloods. Although the literature contains many reports and controversies concerning the limits that may be considered as normal for the various substances determined, it is not the purpose of this study to enter into any discussion of the relative merits of the results of the various investigators or to set new limits or to confirm old ones. That no hard and fast lines can be drawn for the limits within which the amounts of any individual component may be supposed to fall to

TABLE III.
Order of Variability of Blood Constituents in the Individual.

	1	2	3	4	5	6	7	8	9
	<i>per cent</i>	<i>per cent</i>	<i>per cent</i>	<i>per cent</i>	<i>per cent</i>	<i>per cent</i>	<i>per cent</i>	<i>per cent</i>	<i>per cent</i>
Creatinine N.....	50	25	17			8			
Total N.....	17	25	8	25	8	8	8		
Non-protein N.....	8	8	17	17	17	25		8	
Creatine N.....	8		8	25	33	17	8		
Sugar.....		25	8	8	17			25	17
Amino-acid N.....	17		8	17	8	17	17	17	
Uric acid N.....		8			8	8	58	17	
Urea N.....		8	17		8	17	8	25	17
Rest N.....			17			8		8	67

be considered normal in amount is amply evidenced by the studies of Addis and Watanabe (21), McLean and Selling (22), and others. The conservative opinion seems to be that except in extreme cases it is the blood picture as a whole that is indicative of a pathological condition, rather than the amount of any particular constituent which for the moment may be exhibiting an abnormality that may be more apparent than real.

In order to save space and repetition Table IV is limited to the figures representing the range within which the various substances fluctuate, the averages of the amounts found, the average deviation for each constituent, and the relative variability. The absolute values are given in terms of nitrogen per 100 cc. of blood and are arranged in the order of their increasing variability.

In general it can be said that a comparison of the range of variation observed in these results with the reported findings of other workers shows a general agreement in values. It is to be remembered that the figures represent the extreme limits found and that where they appear to differ materially from the so called normal limits they nevertheless may properly be considered as within what might be expected in the sense of the theory of probability.

An inspection of the average deviations makes evident that they are not simply related to the absolute amounts of the respective substances but rather express differences in the susceptibility of the constituents to variation. A comparison of the

TABLE IV.

Range of Variation, Average Amounts, Average Deviations, and Relative Variability of the Blood Constituents Determined.

	Range.	Average.	Average deviation.	Relative variability.
	<i>mg.</i>	<i>mg.</i>	<i>per cent</i>	
Creatinine N.....	0.37-0.60	0.47	7.3	100
Non-protein N.....	27.3-45.5	35.6	9.1	125
Total N.....	2560-4290	307.0	9.4	129
Creatine N.....	0.62-1.78	1.31	11.5	158
Sugar.....	85-166	112.0	13.7	188
Uric acid N.....	0.50-1.16	0.78	14.9	204
Amino-acid N.....	3.1-7.2	4.9	15.3	210
Urea N.....	9.7-25.1	17.1	16.6	227
Rest N.....	3.7-18.3	11.1	20.1	275

order of variation here obtained with that shown in Table III demonstrates that no significant changes have occurred, the interchange of position of the total nitrogen and the non-protein nitrogen, as well as that occurring in the amino-acid and uric acid nitrogen, being due to quantitatively negligible differences.

Such being the case we have an interesting sequence in variability of the constituents under investigation. The causes of these differences in variability cannot be attributed solely to differences in amounts or nature of absorbed material since the order of variability tends to be the same in different individuals presumably ingesting quantitatively different diets. Nor can these differences be wholly ascribed to individual differences in

metabolic stability. It would appear as if the order of variability here manifested is rather the expression of an underlying uniformity of metabolic mechanism specific for the species.

The significance of the position of the various constituents in Table IV is not wholly obvious. They can be, however, divided roughly into three groups, one of relatively low variability containing the creatinine, the total non-protein nitrogen, and the total nitrogen; one of intermediate variability, into which fall the creatine and sugar; and one of relatively high variability containing the uric acid, amino-acid, and urea nitrogen.

The fact that the creatinine appears to be the least susceptible to variation would lend additional support to the conception of Folin and Denis (23) that this substance is the result of a uniform endogenous process and that it represents a certain particular form of protein metabolism.

The relatively low variability of the total non-protein nitrogen is in part accounted for by compensatory variations in deviation occurring between the urea nitrogen, the amino-acid, and rest nitrogen. The variability of the total nitrogen is probably due as much to differences in water intake as to individual differences (24).

The differences in the stability of the metabolic factors leading to the production of creatinine and creatine are well emphasized in the 60 per cent greater variability of the latter.

The factors concerned in the regulation of the amounts of sugar in the blood have been quite fully discussed in a recent publication by Grote (25). It is evident from Table IV that the sugar variability lies near the middle of the scale.

The relatively high variability of the uric acid is probably due to variations in the activity of the endogenous processes giving rise to this blood constituent. According to Mareš (26) these processes are largely confined to the nuclei of the digestive glands, but recent work of Lewis, Dunn, and Doisy (27) has shown that there is a general nuclear activity induced by a stimulative effect of the amino-acids. That the source of the variability is endogenous is strengthened by the findings of Denis (28) that the concentration of uric acid in the blood does not rise in normal individuals during the ingestion of purine-containing foods.

Both Folin and Denis (29) and Van Slyke and Meyer (30) have shown the existence of an interrelation between the metabolic factors concerned with the concentration of amino-acids and urea in the blood, and in view of our present ideas concerning their metabolism a relatively high variability in their concentration is not unexpected. The rest nitrogen will be considered later.

Influence of Time of Withdrawal of Blood on Its Composition.

Although Gettler and Baker (3) state that the concentrations of the various components of the blood fall within normal limits

TABLE V.

Differences in Concentration of Total Nitrogen, Non-Protein Nitrogenous Constituents, and Sugar in Bloods Taken before and after Breakfast.

	Total N.	Non- protein N.	Urea N.	Creati- nine N.	Crea- time N.	Uric acid N.	Amino- acid N.	Rest N.	Sugar.
Sets 7-7'.									
	gm.	mg.	mg.	mg.	mg.	mg.	mg.	mg.	mg.
Before.....	3.04	53.5	31.4	0.55	1.41	2.01	5.8	12.3	110
After.....	3.04	54.6	37.0	0.58	1.40	2.18	6.4	12.6	99
Sets 8-8'.									
Before.....	3.29	34.4	15.0	0.47	1.30	0.71	5.3	11.7	103
After.....	3.29	35.0	15.6	0.47	1.26	0.81	5.0	11.9	108
Sets 9-9'.									
Before.....	3.17	34.1	20.1	0.47	1.36	0.60	5.4	6.2	114
After.....	3.17	39.7	22.7	0.53	1.41	0.82	5.8	8.4	108

whether the blood is taken before or 3 hours after breakfast, and Addis and Watanabe (21) confirm this for urea, it is advisable to make a detailed comparison of bloods taken from the same individuals before and 3½ hours after breakfast for obvious practical reasons. In Table I Sets 7, 8, and 9 are from bloods taken at weekly intervals 3½ hours after the morning meal. Sets 7', 8', and 9' are bloods from the same individuals in the order given, taken at weekly intervals before breakfast. To facilitate comparison Table V presents the data in a condensed form. The absolute amounts are the averages for the four weekly determinations on each individual.

It is seen that there is no practical difference in the concentration of the various constituents determined in blood taken 14 and 3½ hours after eating. From the metabolic point of view the blood taken before breakfast shows evidence of a slightly lower metabolism at this period. The non-protein nitrogen, the urea nitrogen, and the uric acid nitrogen are consistently lower, but to a very small extent. It is seen that, as others have shown in similar comparisons, the sugar may be somewhat higher after the longer fast (31). The changes in the average deviations are generally indeterminate.

Nitrogen Distribution in the Blood.

Our present conception of protein metabolism is largely derived from the studies of Folin (32) on the laws governing the chemical composition of the urine. These studies are based on the differences in the nitrogen and sulfur distribution in urines of high and low total nitrogen content. The sharp differences observed in the nitrogen distribution in such urines, however, cannot be expected in the blood. There is, however, a definite tendency for a change in nitrogen distribution to take place with changes in the level of the total non-protein nitrogen. In Table VI are given the analyses previously summarized in Table IV, as nitrogen per 100 cc. of blood, and the per cent of nitrogen of each constituent in terms of the total non-protein nitrogen. The values for the individual samples of blood have been arranged in the order of descending values of the non-protein nitrogen.

With a decrease in the value of the total non-protein nitrogen there is a general tendency for a simultaneous decrease in the absolute amounts of the urea, creatine, uric acid, and amino-acid nitrogen, of which the urea reduction is the most uniform. There are differences in the degree to which these constituents decrease with the non-protein nitrogen, the urea showing relatively the greater diminution. The rest nitrogen seems to be less affected by a change in the non-protein nitrogen level.

The lack of definite change in the concentration of creatinine nitrogen is significant in that the concentration is thus shown to be independent of that of the total non-protein nitrogen.

TABLE VI.

The Amounts and Percentages in Terms of Non-Protein Nitrogen of the Non-Protein Nitrogenous Constituents of 100 Cc. of Human Blood.

No.	Non-protein N.		Urea N.		Creatinine N.		Creatine N.		Uric acid N.		Amino-acid N.		Rest N.	
	mg.	per cent	mg.	per cent	mg.	per cent	mg.	per cent	mg.	per cent	mg.	per cent	mg.	per cent
1	45.5	23.8	52.4	0.54	1.2	1.49	3.3	0.82	1.8	6.3	13.8	12.5	27.6	
2	43.8	25.1	57.3	0.41	0.9	1.35	3.2	0.77	1.8	4.9	11.2	11.3	25.8	
3	43.2	20.1	46.5	0.44	1.0	1.25	2.9	0.70	1.6	4.5	10.4	16.2	37.5	
4	42.9	24.8	57.8	0.44	1.0	1.22	2.8	0.73	1.7	6.2	14.5	9.5	22.1	
5	42.3	20.0	47.3	0.52	1.2	1.25	3.2	0.77	1.8	5.4	12.8	14.2	33.6	
6	41.4	19.5	47.1	0.48	1.2	1.44	3.5	0.70	1.7	6.3	15.2	13.0	31.4	
7	40.5	15.6	38.5	0.44	1.1	1.57	3.9	0.77	1.9	3.9	9.6	18.3	45.2	
8	40.0	22.1	55.2	0.53	1.3	1.30	3.3	0.99	2.5	5.4	13.3	9.8	24.5	
9	40.0	22.6	56.4	0.43	1.1	1.71	4.3	0.57	1.4	5.9	14.8	8.8	22.0	
10	39.0	20.1	51.5	0.48	1.2	1.22	3.1	0.90	2.3	4.3	11.0	12.0	30.7	
11	39.0	21.1	54.1	0.48	1.2	1.22	3.1	0.96	2.5	4.5	11.6	10.7	27.4	
12	38.7	21.1	54.8	0.52	1.3	1.47	3.8	0.73	1.7	3.4	8.8	11.4	29.5	
13	38.7	16.9	43.5	0.50	1.3	1.25	3.2	0.96	2.5	5.0	12.9	14.1	36.5	
14	38.7	19.8	51.1	0.60	1.6	1.25	3.2	0.83	2.1	4.5	11.6	11.7	30.2	
15	38.4	17.6	45.8	0.48	1.3	1.41	4.1	1.16	3.0	4.7	12.1	13.1	34.1	
16	38.4	18.5	48.2	0.44	1.1	1.78	4.6	0.87	2.3	3.9	10.2	12.9	33.6	
17	38.1	21.4	56.1	0.48	1.3	1.16	3.1	0.93	2.4	4.1	10.8	10.0	26.3	
18	37.8	18.2	48.3	0.48	1.3	1.15	3.0	0.83	2.2	4.7	12.4	12.4	32.8	
19	37.5	15.9	42.4	0.48	1.3	1.41	3.8	0.83	2.2	4.8	12.8	14.1	37.6	
20	37.5	15.5	41.3	0.52	1.4	1.22	3.3	0.73	1.9	6.1	16.3	13.4	35.7	
21	37.3	21.3	57.1	0.53	1.4	1.38	3.7	0.82	2.2	5.7	15.3	7.6	20.4	
22	37.3	19.2	51.6	0.44	1.2	1.44	3.9	0.56	1.5	6.0	16.0	9.6	25.8	
23	36.6	22.0	60.1	0.41	1.1	1.44	3.9	0.80	2.2	5.4	14.7	6.6	18.0	
24	36.3	17.5	48.2	0.44	1.2	1.22	3.4	1.03	2.8	4.8	13.2	11.3	31.1	
25	36.0	13.3	37.0	0.44	1.2	1.60	4.4	1.00	2.8	7.2	20.0	12.5	34.7	
26	35.9	15.3	42.6	0.48	1.3	1.06	3.0	0.67	1.9	4.1	11.4	14.3	38.8	
27	35.9	23.6	65.7	0.54	1.5	1.48	4.1	0.69	1.9	5.9	16.5	3.7	10.4	
28	35.7	16.4	45.9	0.44	1.2	1.31	3.7	0.70	2.0	4.8	13.4	12.0	33.6	
29	35.4	18.4	52.0	0.44	1.2	1.35	3.8	0.90	2.5	5.0	14.1	9.3	26.3	
30	34.8	15.0	43.1	0.48	1.4	1.52	4.4	0.70	2.0	4.6	13.2	12.5	35.9	
31	34.8	15.5	44.3	0.41	1.2	0.99	2.8	0.83	2.4	3.6	10.3	13.6	38.8	
32	34.6	13.1	37.9	0.43	1.2	1.19	3.4	0.70	2.0	5.3	15.3	13.9	40.2	
33	34.5	17.7	51.3	0.48	1.4	1.31	3.8	1.07	3.1	5.1	14.8	8.8	25.6	
34	34.5	17.7	51.2	0.40	1.2	1.45	4.2	0.61	1.8	5.6	16.1	8.8	25.6	
35	34.2	11.8	34.5	0.44	1.3	0.96	2.5	0.70	2.1	3.7	10.8	16.6	48.6	
36	33.9	15.1	44.5	0.48	1.4	0.93	2.7	0.80	2.3	5.3	15.6	11.2	33.0	
37	33.7	16.6	49.2	0.46	1.4	1.20	3.6	0.79	2.3	6.1	18.1	8.6	25.5	
38	33.7	16.7	49.5	0.48	1.4	1.48	4.4	0.73	2.2	6.6	19.5	7.8	23.1	

612 Nitrogenous Constituents of Human Blood

TABLE VI—*Concluded.*

No.	Non-protein N.		Urea N.		Creatinine N.		Creatine N.		Uric acid N.		Amino-acid N.		Rest N.	
	mg.	per cent	mg.	per cent	mg.	per cent	mg.	per cent	mg.	per cent	mg.	per cent	mg.	per cent
39	33.6	17.7	52.7	0.44	1.3	0.96	2.9	0.73	2.3	5.7	17.0	8.1	24.3	
40	33.6	11.1	33.0	0.41	1.2	1.38	4.1	0.63	1.9	4.0	11.9	16.1	48.1	
41	33.6	13.3	39.6	0.52	1.5	1.35	4.1	1.16	3.5	5.6	16.7	11.6	34.5	
42	33.1	15.9	47.9	0.48	1.4	1.42	4.3	0.79	2.4	3.6	10.9	11.0	33.1	
43	33.0	12.2	37.0	0.52	1.6	1.38	4.2	0.67	2.0	4.0	12.1	14.2	43.0	
44	33.0	15.4	46.7	0.48	1.5	1.19	3.6	0.70	2.1	5.4	16.4	9.8	29.8	
45	33.0	12.3	37.3	0.52	1.6	1.35	4.2	0.77	2.3	4.0	12.1	14.1	42.7	
46	32.8	18.3	55.8	0.48	1.5	1.35	4.1	0.70	2.1	3.6	11.0	8.4	25.6	
47	32.4	16.6	51.3	0.48	1.5	1.60	4.9	0.67	2.1	5.3	16.4	7.7	23.8	
48	32.4	14.8	46.0	0.41	1.3	1.47	4.5	0.50	1.5	4.3	13.3	10.8	33.3	
49	32.4	15.1	46.6	0.48	1.5	1.41	4.4	0.53	1.6	4.8	14.8	10.1	31.5	
50	32.4	16.3	50.3	0.52	1.6	1.12	3.5	0.70	2.2	3.9	12.0	9.9	30.6	
51	32.1	16.6	51.7	0.44	1.4	1.16	3.4	0.87	2.7	4.7	14.6	8.3	25.9	
52	31.8	12.8	40.3	0.44	1.4	1.38	4.3	0.73	2.5	5.0	15.7	11.4	35.8	
53	31.7	17.0	53.7	0.43	1.4	1.03	3.3	0.60	1.9	3.9	12.4	8.7	27.4	
54	31.5	17.6	55.9	0.44	1.4	1.15	3.6	0.70	2.2	5.0	15.9	6.6	20.9	
55	30.6	12.5	40.9	0.48	1.6	1.35	4.4	1.10	3.6	6.7	21.9	8.5	27.8	
56	30.0	14.4	48.0	0.48	1.6	1.16	3.9	0.83	2.8	4.1	13.7	9.0	30.0	
57	29.7	13.3	44.1	0.41	1.4	1.25	4.2	0.90	3.0	3.1	10.4	10.9	36.7	
58	28.8	11.3	39.2	0.48	1.7	1.28	4.4	0.73	2.5	5.0	17.4	10.0	34.7	
59	28.2	15.8	55.9	0.48	1.7	0.63	2.2	0.65	2.3	3.9	13.9	6.7	23.8	
60	27.3	9.7	35.5	0.37	1.4	1.35	4.9	0.57	2.1	4.3	15.8	11.0	40.3	
Average...	35.6	17.1	47.8	0.47	1.3	1.30	3.7	0.78	2.2	4.9	13.8	11.0	31.1	

If instead of the concentrations we consider the percentages of the total non-protein nitrogen which they represent, it is evident that in the blood as in the urine (33) the distribution of the nitrogen among the urea and the other nitrogenous constituents is dependent upon the absolute amounts of the total non-protein nitrogen present. For not only does the urea nitrogen tend to decrease in absolute amounts but also the percentage of the total non-protein nitrogen as urea nitrogen tends to decrease with the fall in the absolute amounts of the total non-protein nitrogen. This fall in percentage of urea nitrogen indicates that with falling total non-protein nitrogen the blood urea tends to decrease in concentration to a relatively greater extent than do the other constituents.

In order to bring out the existence of any specific relations between one constituent and the others, the absolute amounts of each component were arranged in the order of their descending value without regard to origin and compared with the corresponding values of the other constituents. It was found that when the urea nitrogen was used as the basis for comparison the only significant relation to be observed lay in the fact that there was a tendency for the rest nitrogen to increase in absolute amounts with the decrease in the urea nitrogen.

Similar comparisons using the creatinine, creatine, uric acid, and amino-acid nitrogen respectively as a basis have revealed no significant interrelations. The ratio between the creatinine and creatine nitrogen is quite variable, the creatinine nitrogen ranging from 24 to 76 per cent of the creatine nitrogen as the extreme limits, the common limits being from 27 to 46 per cent. About 13 per cent of the values of the ratio lie between 24 and 28 per cent, 77 per cent between 30 and 45 per cent, and 10 per cent between 46 and 76 per cent.

SUMMARY.

These studies of the chemical composition of human blood indicate:

1. While the total nitrogen, non-protein nitrogenous constituents, and the sugar of the blood vary in the same individual from week to week, there is a tendency for the level of these variations to be characteristically individual.

2. The sum of the average deviations of the constituents for any given individual may be an index of the metabolic stability of that individual.

3. The order of relative variability of the constituents determined is: creatinine, total non-protein nitrogen, total nitrogen, creatine, sugar, uric acid, amino-acid, urea, and rest nitrogen. A rough division can be made into groups of low, intermediate, and high variability.

4. There is no practical difference between the absolute amounts of the constituents found in bloods taken 14 hours after eating, *i.e.* before breakfast, and 3½ hours after this meal. The slightly lower values found before breakfast for the non-protein, urea, and uric acid nitrogen are taken as meaning a lessened metabolism.

5. The absolute amounts of the urea, creatine, uric acid, amino-acid, and rest nitrogen tend to decrease with decrease in level of the total non-protein nitrogen. The urea decreases to relatively the greatest extent.

6. The absolute amount of creatinine is a constant for the individual and for the species. It is independent of quantitative changes in the level of the non-protein nitrogen; of the changes in the concentrations of any of the other constituents determined; and of the individual variations in metabolic stability.

7. There is no uniform quantitative relation between the amounts of the creatinine and creatine nitrogen in the blood.

8. The distribution of the non-protein nitrogen among urea and the other soluble nitrogenous constituents of the blood is dependent to a great degree upon the absolute amounts of the total non-protein nitrogen present.

9. The nitrogenous constituents of blood that are commonly found in the urine, *e.g.* urea, creatinine, and uric acid, seem to undergo the same type of absolute and relative change with change in level of the total non-protein nitrogen of the blood as they do with the change from the high to low total nitrogen in the urine.

10. The relative as well as the absolute decline in the urea nitrogen of the blood accompanying the decrease in the total non-protein nitrogen is compensated for by a relatively lesser absolute decrease in all the other nitrogenous constituents, which results in an increase of the percentage of their nitrogen in terms of the non-protein nitrogen.

11. The only apparent interrelation existing between any of the individual constituents is that between the urea and the rest nitrogen. There is a tendency for a rise or fall in the blood urea to be accompanied by a change in the opposite direction of the rest nitrogen.

BIBLIOGRAPHY.

1. Folin, O., and Denis, W., *J. Biol. Chem.*, 1912, xi, 527.
2. Folin, O., *J. Biol. Chem.*, 1914, xvii, 475.
3. Gettler, A. O., and Baker, W., *J. Biol. Chem.*, 1916, xxv, 211.
4. Bang, I., *Biochem. Z.*, 1915, lxxii, 104.
5. Feigl, J., *Biochem. Z.*, 1918-19, xciv, 84; *Arch. exp. Path. u. Pharmacol.*, 1918, lxxxiii, 168.
6. Folin, O., *Am. J. Insanity*, 1904-05, lxi, 299.
7. Tracy, M., and Clark, E. E., *J. Biol. Chem.*, 1914, xix, 115.
8. Raiziss, G. W., Dubin, H., and Ringer, A. I., *J. Biol. Chem.*, 1914, xix, 473.
9. Addis, T., and Watanabe, C. K., *Arch. Int. Med.*, 1917, xix, 507.
10. Van Slyke, D. D., and Cullen, G. E., *J. Biol. Chem.*, 1917, xxx, 289.
11. Folin, O., and Farmer, C. J., *J. Biol. Chem.*, 1912, xi, 493.
12. Folin, O., and Wu, H., *J. Biol. Chem.*, 1919, xxxviii, 87.
13. Benedict, S. R., *J. Biol. Chem.*, 1914, xviii, 183.
14. Folin, O., and Doisy, E. A., *J. Biol. Chem.*, 1916-17, xxviii, 349.
15. Kendall, E. C., *J. Biol. Chem.*, 1919, xxxviii, 529.
16. Whipple, G. H., and Van Slyke, D. D., *J. Exp. Med.*, 1918, xxviii, 213.
17. Van Slyke, D. D., *J. Biol. Chem.*, 1912, xii, 278.
18. Hammett, F. S., *J. Biol. Chem.*, 1918, xxxiii, 381.
19. Gad-Andersen, K. L., *J. Biol. Chem.*, 1919, xxxix, 267.
20. Folin, O., *J. Biol. Chem.*, 1919, xxxix, 259.
21. Addis, T., and Watanabe, C. K., *J. Biol. Chem.*, 1916, xxvii, 267.
22. McLean, F. C., and Selling, L., *J. Biol. Chem.*, 1914, xix, 31.
23. Folin, O., Hammarsten's Festschrift, 1906. Folin, O., and Denis, W., *J. Biol. Chem.*, 1914, xvii, 493.
24. Terroine, E.-F., *Compt. rend. Soc. biol.*, 1914, lxxvi, 523.
25. Grote, L. R., *Über die Beziehungen der Muskelarbeit zum Blutzucker*, Marhold, 1918.
26. Mareš, F., *Arch. ges. Physiol.*, 1910, cxxxiv, 59.
27. Lewis, H. B., Dunn, M. S., and Doisy, E. A., *J. Biol. Chem.*, 1918, xxxvi, 9.
28. Denis, W., *J. Biol. Chem.*, 1915, xxiii, 147.
29. Folin, O., and Denis, W., *J. Biol. Chem.*, 1912, xii, 141.
30. Van Slyke, D. D., and Meyer, G. M., *J. Biol. Chem.*, 1912, xii, 399.
31. Jacobsen, A. T. B., *Biochem. Z.*, 1913, lvi, 471; *Undersogelser over Blodsukkerindholdet hos normale og ved diabetes mellitus*, Copenhagen, 1917.
32. Folin, O., *Am. J. Physiol.*, 1905, xiii, 117.
33. Folin, O., *Am. J. Physiol.*, 1905, xiii, 66.



THE HEAT COAGULATION OF MILK.

BY H. H. SOMMER AND E. B. HART.

(From the Department of Agricultural Chemistry, University of Wisconsin, Madison.)

(Received for publication, March 2, 1920.)

In our article with the above title published in this *Journal* in November, 1919, the temperature of 136°C. was chosen as a suitable one for the detection of milks liable to coagulate in the condensing process. Mr. George Grindrod, now with the Carnation Milk Products Company of Oconomowoc, Wisconsin, was the first to employ high temperatures in a "heat test" as suitable for the detection of such condition and to have used such temperatures with the autoclave. In our paper we failed to give Mr. Grindrod credit for having made use of this means of testing milk for coagulation effects. We now wish to correct this error of omission.

In our paper we mentioned the disadvantage of using the autoclave for heating the milk and reported on our modification of using sealed tubes in a xylene bath at 136°C. In our later correspondence with Mr. Grindrod he claims that he had also used the sealed tube method for a period of 3 years, although he had not published any description of this test or given us any information of a similar import.



A NEW 0.1 N CALOMEL ELECTRODE DESIGN.

By A. E. KOEHLER.

(From the Laboratory of Agricultural Chemistry, University of Wisconsin, Madison.)

(Received for publication, March 1, 1920.)

In accurate H ion concentration work the 0.1 N calomel electrode is nearly universally used, mainly because its E. M. F. is not nearly so readily affected by temperature change as the saturated type.

Furthermore, a saturated KCl solution, unless in a tightly sealed vessel, is disagreeable to work with because of the tendency of the salt to creep from the solution.

However, it is apparent that the 0.1 N electrode can be used to advantage only when the normality remains perfectly constant. When the 0.1 N electrode is used with the necessary saturated KCl bridge, this becomes a problem.

Various appliances are in use and practically all depend on a very small opening at the end of the side-arm of the calomel electrode. Diffusion is only hindered at best and the arm has to be washed out with the solution from the electrode vessel. Furthermore, the side-arm must remain in the saturated KCl solution only when necessary, so the arrangement is not permanent.

We are using a design in several H ion concentration apparatus which seems to overcome these difficulties completely. Its use was practically imperative in a problem where several determinations were made each day over a long period of time, inasmuch as the electrode chain could be set up permanently without any change in normality of the 0.1 N KCl or any creeping of salts.

During a period of nearly 2 months of continual use the E. M. F. of the calomel electrode had not changed in the least.

The design can readily be understood from the diagram. The apparatus is clamped to a horizontal bar and the lower tube from stop-cock C connected by a large flexible rubber tube to

the Clark or McClendon electrode mounted on the usual shaking arm. The vertical arm from stop-cock C is connected to a bottle of saturated KCl solution which usually is placed well back of the apparatus so as to be out of the way. The same is true of the bottle of 0.1 \times KCl solution which is connected to the other vertical arm.

Contact is made between the 0.1 \times KCl and the saturated KCl solution around the closed, ungreased stop-cock B. Stop-cock A, which is greased with pure vaseline, is opened so as to connect the

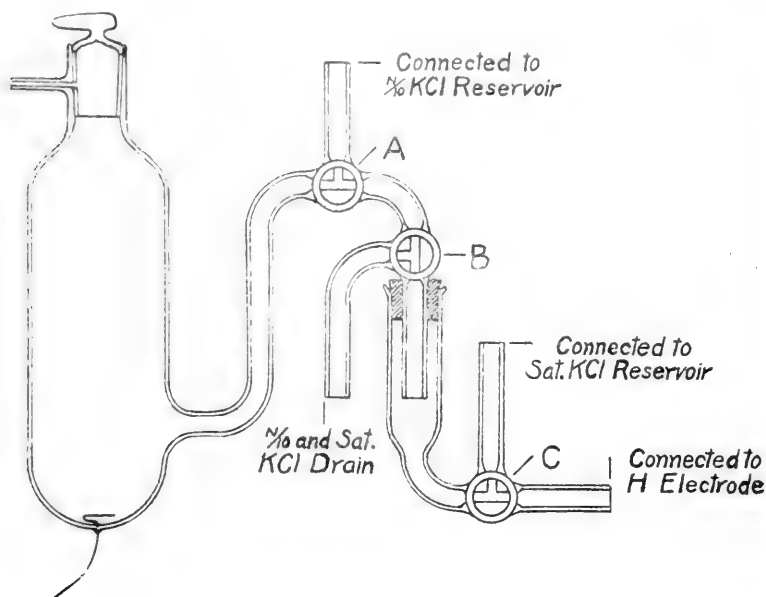

FIG. 1

electrode vessel with the bridge *only* when making a reading. Immediately after making a reading by the proper manipulation of stop-cocks A and B the section from A to B is thoroughly washed out through the side drain arm with fresh 0.1 \times KCl from the reservoir.

In a similar manner any 0.1 \times KCl can be washed from the saturated KCl below stop-cock B.

This apparatus thus gives a permanently closed system which minimizes contamination of the 0.1 \times solution of the calomel electrode.

INDEX TO VOLUME XLI.

- ACETALDEHYDE**, methane, and sodium acetate, effect on catalase production of the chlorine substitution products of, 307
- Acetate, mercuric, oxidation of sugars in the presence of ammonia, 147
- , sodium, methane, and acetaldehyde, effect on catalase production of the chlorine substitution products of, 307
- Acetone and butyl alcohol fermentation of starch by *Bacillus granulobacter pectinovorum*, 319
- bodies, formation following ether anesthesia and their relation to the plasma bicarbonate, 503
- Acid, carbonic, and oxygen, equilibrium in blood, 401
- , citric, in the tomato, identification of, 15
- , crystalline uridinphosphoric, 1
- , yeast nucleic, properties of the nucleotides from, 483
- , — — —, structure, 19
- Acidosis studies, 191, 567
- Acids, higher fatty, and cholesterol, nephelometric values, 243
- , organic, in urine, titration, 567
- ALBRECHT, P. G. Effect of iodides on the autolysis of liver tissue, 111
- Albumin, fibrin. and globulin of blood plasma, determination, 587
- Alcohol, butyl, and acetone fermentation of starch by *Bacillus granulobacter pectinovorum*, 319
- Alkali reserve of the plasma, effect of sleep, 473
- Alkaline reserve capacity of whole blood and carbohydrate mobilization as affected by hemorrhage, 59
- Ammonia hydrolysis of yeast nucleic acid, 19
- , oxidation of sugars by mercuric acetate in the presence of, 147
- Analysis, blood, 367
- Anesthesia, ether, formation of acetone bodies following, and their relation to the plasma bicarbonate, 503
- Aqueous solution, influence of hydrogen ion concentration upon the volatility of indole from, 37
- Arterial and venous blood plasma, carbon dioxide content and capacity, 191
- Aspergillus niger*, utilization of α -methylglucoside, 475
- AUSTIN, J. HAROLD, and VAN SLYKE, DONALD D. Determination of chlorides in whole blood, 345
- Autolysis of liver tissue, effect of iodides, 111
- BACILLUS granulobacter pectinovorum**, biochemistry of acetone and butyl alcohol fermentation of starch by, 319
- Bacteria, pentose-fermenting, rôle in the production of corn silage, 181
- BAGG, HALSEY J. See THEIS and BAGG, 525

- Barley, oat, rye, and wheat kernels, nutritive value of the proteins, 275
- BARTLETT, H. H. See SANDO and BARTLETT, 495
- BAUMAN, L. See INGVALDSEN and BAUMAN, 145, 147
- Bean, navy, *Phaseolus vulgaris*, rôle of cystine in nutrition as exemplified by nutrition experiments with the proteins of, 379
- Beckmann thermometer, thermoregulator with the characteristics of, 9
- Bicarbonate, plasma, formation of acetone bodies following ether anesthesia and their relation to, 503
- Blood analysis, 367
- , determination of magnesium, 363
- , direct quantitative determination of potassium and sodium in small quantities of, 263
- , effects of feeding with calcium salts on the calcium content of, 357
- , equilibrium between oxygen and carbonic acid, 401
- , human, studies of variations in the chemical composition, 599
- , method for determination of methemoglobin, 237
- , of several invertebrate animals, chemical study, 119
- , plasma, carbon dioxide content and capacity in arterial and venous, 191
- , —, —, determination of the fibrin, globulin, and albumin nitrogen, 587
- , whale, chemical study, 137
- , whole, alkaline reserve capacity, and carbohydrate mobilization as affected by hemorrhage, 59
- Blood, whole, determination of chlorides, 315
- BOUTWELL, P. W. See STEENBOCK and BOUTWELL, 81, 163
- BUCKNER, G. DAVIS, and MARTIN, J. H. Effect of calcium on the composition of the eggs and carcass of laying hens, 195
- BUNKER, JOHN W. M. The determination of hydrogen ion concentration, 11
- BURGE, E. L. See BURGE and BURGE, 307
- BURGE, W. E., and BURGE, E. L. Effect of the chlorine substitution products of methane, acetaldehyde, and of sodium acetate on catalase production, 307
- Butyl alcohol and acetone fermentation of starch by *Bacillus granulobacter pectinovorum*, 319
- CALCIUM, effect on composition of eggs and carcass of laying hens, 195
- , of carrots, utilization by man, 349
- , salts, effects of feeding on the calcium content of the blood, 357
- Calomel electrode design, a new 0.1 N, 619
- Carbohydrate in vegetables, availability, 45
- , mobilization and alkaline reserve capacity of whole blood as affected by hemorrhage, 59
- Carbon dioxide content and capacity in arterial and venous blood plasma, 191
- Carbonic acid and oxygen, equilibrium in blood, 401
- Carrots, utilization by man of calcium of, 349
- Catalase production, effect of the chlorine substitution products of methane, acetaldehyde, and sodium acetate, 307

- Chlorides, determination in whole blood, 345
- Chlorine method, official, short modification for feeds, feces, and urine, 205
- , substitution products of methane, acetaldehyde, and of sodium acetate, effect on catalase production, 307
- Cholesterol and the higher fatty acids, nephelometric values, 243
- Citric acid in the tomato, identification of, 15
- Coagulation of milk by heat, 617
- COHEN, SEYMOUR J. Studies on the secretion of gastric juice, 257
- COLLIP, J. B. Effect of sleep upon the alkali reserve of the plasma, 473
- Corn gluten meal, commercial, nutritive value, 391
- silage, rôle of pentose-fermenting bacteria in the production of, 181
- Crystalline uridiphosphoric acid, 1
- CSONKA, F. A. A study of the nephelometric values of cholesterol and the higher fatty acids. II, 243
- CULLEN, GLENN E., and VAN SLYKE, DONALD D. Determination of the fibrin, globulin, and albumin nitrogen of blood plasma, 587
- Cystine, rôle of, in nutrition as exemplified by nutrition experiments with the proteins of the navy bean, *Phaseolus vulgaris*, 379
- DENIS, W., and MINOT, A. S. Effects of feeding with calcium salts on the calcium content of the blood, 357
- , Determination of magnesium in blood, 363
- Determination, direct quantitative, of potassium and sodium in small quantities of blood, 263
- of chlorides in whole blood, 345
- — hemoglobin by various methods, 209
- — hydrogen ion concentration, 11
- — magnesium in blood, 363
- — methemoglobin in blood, method, 237
- — saccharin in urine, 3
- — sugar in blood, a simplified and improved method, 367
- — the fibrin, globulin, and albumin nitrogen of blood plasma, 587
- — — refractivity of hemoglobin in solution, 537
- , quantitative, of indole in biological media, 25
- DEUEL, HARRY J., JR. See HOLMES and DEUEL, 227
- Digestibility of certain miscellaneous vegetable fats, 227
- — chicken skin, 469
- p*-Dimethylaminobenzaldehyde, preparation of, 145
- Dioxide, carbon, content and capacity in arterial and venous blood plasma, 191
- DOX, ARTHUR W., and ROARK, G. W., JR. The utilization of α -methylglucoside by *Aspergillus niger*, 475
- Duodenum, human, hydrogen ion concentration of, 187
- EGGS and carcass of laying hens, effect of calcium on composition of, 195
- Electrode design, a new 0.1 N calomel, 619
- Escholtzia californica* Cham., rutin, the flavone pigment of, 495
- Ether anesthesia, formation of acetone bodies following, and their relation to the plasma bicarbonate, 503

- FATS**, vegetable, digestibility of certain miscellaneous, 227
- Fat-soluble vitamin, 81, 149, 163, 549
- content of green plant tissues together with some observations on their water-soluble vitamin content, 149
- — —, thermostability in plant materials, 163
- Feces, feeds, and urine, short modification of the official chlorine method for, 205
- Feeds, feces, and urine, short modification of the official chlorine method for, 205
- Fermentation of fructose by *Lactobacillus pentosecticus*, n. sp., 431
- — — starch by *Bacillus globulifer pastinacorum*, biochemistry of the acetone and butyl alcohol, 319
- Fibrin, globulin, and albumin nitrogen of blood plasma, determination, 587
- FINKS, A. J., and JOHNS, CARL O. Distribution of the basic nitrogen in phaseolin, 375
- See JOHNS and FINKS, 379
- See JOHNS, FINKS, and PAUL, 391
- Flavone pigment of *Escholtzia californica* Cham., rutin, 495
- FOLIN, OTTO, and WU, HSIEN. A system of blood analysis. Supplement I. A simplified and improved method for determination of sugar, 367
- FRED, E. B. See PETERSON and FRED, 181, 431
- Fructose, fermentation by *Lactobacillus pentosecticus*, n. sp., 431
- GASTRIC** juice, secretion, 257
- Gluten corn meal, commercial, nutritive value, 391
- Globulin, fibrin, and albumin nitrogen of blood plasma, determination, 587
- GROSS, E. G. See STEENBOCK and GROSS, 149
- Gulose, heptoses from, and some of their derivatives, 251
- HALL**, J. A. See KREMERS and HALL, 15
- HALVERSON, J. O., and WELLS, E. B. Note on a short modification of the official chlorine method for feeds, feces, and urine, 205
- HAMMETT, FREDERICK S. Studies of variations in the chemical composition of human blood, 599
- HART, E. B. See SOMMER and HART, 617
- HARVEY, R. B. A thermoregulator with the characteristics of the Beckmann thermometer, 9
- Heat coagulation of milk, 617
- Hemoglobin, 75
- determination by various methods, 209
- in solution, determination of refractivity, 537
- Hemorrhage, alkaline reserve capacity of whole blood and carbohydrate mobilization as affected by, 59
- HENDERSON, LAWRENCE J. The equilibrium between oxygen and carbonic acid in blood, 401
- Heptoses from gulose and some of their derivatives, 251
- HOLMES, ARTHUR D., and DEUEL, HARRY J., JR. Digestibility of certain miscellaneous vegetable fats, 227
- HOWARD, FREDERICK H. The determination of the refractivity of hemoglobin in solution, 537

- Human blood, studies of variations
 in the chemical composition,
 599.
- duodenum, note on hydrogen
 ion concentration of, 187
- Hydrogen ion concentration, deter-
 mination, 11
- — —, influence upon
 volatility of indole from aque-
 ous solution, 37
- — — of the human duo-
 denum, 187
- Hydrolysis, ammonia, of yeast
 nucleic acid, 19
- I**NDOLE from aqueous solution,
 influence of hydrogen ion con-
 centration upon the volatility
 of, 37
- , quantitative estimation in
 biological media, 25
- INGVALDSEN, T., and BATMAN, L.
 Note on the oxidation of sugars
 by mercuric acetate in the
 presence of ammonia, 147
- and —. ————prepa-
 ration of *p*-dimethylaminobenz-
 aldehyde, 145
- Injections, continuous intravenous,
 improved volumetric pump, 315
- , intravenous, of active deposit
 of radium, effect on metabolism
 in the dog, 525
- Intravenous injections, improved
 volumetric pump for continu-
 ous, 315
- — of active deposit of
 radium, effect on metabolism
 in the dog, 525
- Iodides, effect on autolysis of liver
 tissue, 111
- J**AMIESON, GEORGE S. The de-
 termination of saccharin in
 urine, 3
- JOHNS, CARL O., and FINKS, A. J.
 Studies in nutrition. II. The
 rôle of cystine in nutrition as
 exemplified by nutrition exper-
 iments with the proteins of
 the navy bean, *Phaseolus vul-*
garis, 379
- , FINKS, A. J. and PAUL, MABEL
 S. Studies in nutrition. III.
 The nutritive value of commer-
 cial corn gluten meal, 391
- , See FINKS and JOHNS, 375
- K**OEHLER, A. E. A new 0.1 N
 calomel electrode design, 619
- KOHMAN, EDWARD F., and SHONLE,
 H. A. The digestibility of
 chicken skin, 469
- KRAMER, B. Direct quantitative
 determination of potassium
 and sodium in small quantities
 of blood, 263
- KREMERS, R. E., and HALL, J. A.
 On the identification of citric
 acid in the tomato, 15
- L**ACTOBACILLUS *pentoceticus*,
n. sp., fermentation of fructose
 by, 431
- LA FORGE, F. B. The heptoses
 from gulose and some of their
 derivatives, 251
- LEVENE, P. A. Crystalline uridin-
 phosphoric acid, 1
- , Properties of the nucleo-
 tides obtained from yeast
 nucleic acid, 483
- , The structure of yeast nu-
 cleic acid. V. Ammonia hy-
 drolysis, 19
- Liver tissue, effect of iodides on the
 autolysis of, 111
- M**AGNESIUM in blood, deter-
 mination, 363

- Maintenance in man, phosphorus requirement, 173
 ————, protein requirement and the nutritive efficiency of bread protein, 97
- Maizes, comparative nutritive value of white and yellow, 81
- MARTIN, J. H. See BUCKNER and MARTIN, 195
- MCCLENDON, J. F. See MYERS and MCCLENDON, 187
- Media, biological, quantitative estimation of indole in, 25
- MENDEL, LAFAYETTE B. See OSBORNE and MENDEL, 275, 451, 515, 549
- Mercuric acetate, oxidation of sugars in the presence of ammonia, 147
- Metabolism in the dog, effect of intravenous injections of active deposit of radium, 525
- Methane, acetaldehyde, and sodium acetate, effect on catalase production of the chlorine substitution products of, 307
- Methemoglobin in blood, method for determination, 237
- Method for the determination of methemoglobin in blood, 237
 — of blood analysis, 367
 —, official chlorine, for feeds, feces, and urine, short modification, 205
 —, simplified and improved for determination of sugar in blood, 367
- Methods, various, of hemoglobin determination, 209
- α -Methylglucoside, utilization by *Aspergillus niger*, 475
- Milk as a source of water-soluble vitamine, 515
 —, heat coagulation, 617
- MINOT, A. S. See DENIS and MINOT, 357
- MYERS, F. J., and MCCLENDON, J. F. Note on the hydrogen ion concentration of the human duodenum, 187
- MYERS, ROLLIN G. I. A chemical study of the blood of several invertebrate animals, 119, II. A chemical study of whale blood, 137
- NEPHELOMETRIC values of cholesterol and the higher fatty acids, 243
- Nitrogen, basic, distribution in phaseolin, 375
 . determination of the fibrin, globulin, and albumin of blood plasma, 587
- Nucleic acid, yeast, properties of the nucleotides from, 483
 ————, —, structure, 19
- Nucleotides from yeast nucleic acid, properties, 483
- Nutrition experiments with the proteins of the navy bean, *Phaseolus vulgaris*, rôle of cystine, 379
 — studies, 379, 391
- Nutritive efficiency of bread protein and protein requirement of maintenance in man, 97
 — factors in plant tissues, 451, 549
 — value of commercial corn gluten meal, 391
 — — — the proteins of the barley, oat, rye, and wheat kernels, 275
 — — — white and yellow maizes, comparative, 81
- OAT, barley, rye, and wheat . kernels, nutritive value of the proteins, 275
- OLMSTED, W. II. Availability of carbohydrate in certain vegetables, 45
- OSBORNE, THOMAS B., and MENDEL, LAFAYETTE B. Milk as a source of water-soluble vitamine. II, 515
 — and —. Nutritive factors in plant tissues. III. Further observation on the distribution of water-soluble vitamine, 451, IV. Fat-soluble vitamine, 549

- OSBORNE, THOMAS B., and MENDEL, LAFAYETTE B. Nutritive value of the proteins of the barley, oat, rye, and wheat kernels, 275
- Oxidation of sugars by mercuric acetate in the presence of ammonia, 147
- Oxygen and carbonic acid, equilibrium in blood, 401
- P**ALMER, W. W. See VAN SLYKE and PALMER, 567
- PAUL, MABEL S. See JOHNS, FINKS, and PAUL, 391
- Pentose-fermenting bacteria, rôle in the production of corn silage, 181
- PETERSON, W. H., and FRED, E. B. The fermentation of fructose by *Lactobacillus pentoaceticus*, n. sp., 431
- and —. — rôle of pentose-fermenting bacteria in the production of corn silage, 181
- Phaseolin, distribution of the basic nitrogen in, 375
- Phaseolus vulgaris*, navy bean, rôle of cystine in nutrition as exemplified by nutrition experiments with the proteins of, 379
- Phosphorus requirement of maintenance in man, 173
- Pigment, flavone, of *Escholtzia californica* Cham., rutin, 495
- Plasma bicarbonate, formation of acetone bodies following ether anesthesia and their relation to, 503
- , blood, determination of the fibrin, globulin, and albumin nitrogen, 587
- , carbon dioxide content and capacity in arterial and venous blood, 191
- , effect of sleep upon the alkali reserve, 473
- Potassium and sodium in small quantities of blood, direct quantitative determination, 263
- Protein requirement of maintenance in man and the nutritive efficiency of bread protein, 97
- Proteins of the barley, oat, rye, and wheat kernels, nutritive value, 275
- — — — navy bean, *Phaseolus vulgaris*, rôle of cystine in nutrition as exemplified by nutrition experiments, 379
- Pump, improved volumetric, for continuous intravenous injections, 315
- R**ADIUM, effect of intravenous injections of active deposit on metabolism in the dog, 525
- Refractivity of hemoglobin in solution, determination, 537
- Reserve, alkali, of the plasma, effect of sleep, 473
- , alkaline, capacity of whole blood and carbohydrate mobilization as affected by hemorrhage, 59
- ROARK, G. W., JR. See DOX and ROARK, 475
- ROBSCHUIT, FRIEDA S. A comparative study of hemoglobin determination by various methods, 209
- ROSE, MARY SWARTZ. Experiments on the utilization of the calcium of carrots by man, 349
- Rutin, the flavone pigment of *Escholtzia californica* Cham., 495
- Rye, barley, oat, and wheat kernels, nutritive value of the proteins, 275
- S**ACCHARIN in urine, determination, 3
- Salts, calcium, effects of feeding on the calcium content of the blood, 357
- SANDO, CHARLES E., and BARTLETT, H. H. Rutin, the flavone pigment of *Escholtzia californica* Cham., 495

- Secretion of gastric juice, 257
- SHERMAN, H. C. Phosphorus requirement of maintenance in man, 173
- Protein requirement of maintenance in man and the nutritive efficiency of bread protein, 97
- SHONLE, H. A. See KOHMAN and SHONLE, 469
- SHORT, JAMES J. The formation of acetone bodies following ether anesthesia and their relation to the plasma bicarbonate, 503
- Skin, chicken, digestibility, 469
- Sleep, effect upon the alkali reserve of the plasma, 473
- Sodium acetate, methane, and acetaldehyde, effect on catalase production of the chlorine substitution products of, 307
- and potassium in small quantities of blood, direct quantitative determination, 263
- Solution, aqueous, influence of hydrogen ion concentration upon the volatility of indole from, 37
- , determination of refractivity of hemoglobin, 537
- SOMMER, H. H., and HART, E. B. The heat coagulation of milk, 617
- SPEAKMAN, HORACE B. Biochemistry of the acetone and butyl alcohol fermentation of starch by *Bacillus granulobacter pectinovorum*, 319
- STADIE, WILLIAM C. A method for the determination of methemoglobin in blood, 237
- and VAN SLYKE, DONALD D. Studies of acidosis. XV. Carbon dioxide content and capacity in arterial and venous blood plasma, 191
- Starch, biochemistry of the acetone and butyl alcohol fermentation by *Bacillus granulobacter pectinovorum*, 319
- STEENBOCK, H., and BOUTWELL, P. W. Fat-soluble vitamine. III. The comparative nutritive value of white and yellow maize, 81, V. Thermostability of the fat-soluble vitamine in plant materials, 163
- and GROSS, E. G. Fat-soluble vitamine. IV. The fat-soluble vitamine content of green plant tissues together with some observations on their water-soluble vitamine content, 149
- Sugar in blood, simplified and improved method for determination, 367
- Sugars, oxidation by mercuric acetate in the presence of ammonia, 147
- TATUM, ARTHUR L. Alkaline reserve capacity of whole blood and carbohydrate mobilization as affected by hemorrhage, 59
- THEIS, RUTH C., and BAGG, HALSEY J. The effect of intravenous injections of active deposit of radium on metabolism in the dog, 525
- Thermometer, Beckmann, thermoregulator with the characteristics of, 9
- Thermoregulator with the characteristics of the Beckmann thermometer, 9
- Thermostability of the fat-soluble vitamine in plant materials, 163
- Tissue, liver, effect of iodides on the autolysis of, 111
- Tissues, green plant, fat-soluble vitamine content together with some observations on their water-soluble vitamine content, 149
- , nutritive factors in plant, 451, 549
- Titration of organic acids in urine, 537

- Tomato, identification of citric acid in, 15
- URIDINPHOSPHORIC** acid, crystalline, 1
- Urine, determination of saccharin in, 3
- , feeds, and feces, short modification of the official chlorine method for, 205
- , titration of organic acids, 567
- VAN SLYKE, DONALD D., and PALMER, W. W.** Studies of acidosis. XVI. The titration of organic acids in urine, 567
- , See **AUSTIN** and **VAN SLYKE**, 345
- , See **CULLEN** and **VAN SLYKE**, 587
- , See **STADIE** and **VAN SLYKE**, 191
- Vegetable fats, digestibility of certain miscellaneous, 227
- Vegetables, availability of carbohydrate in, 45
- Venous and arterial blood plasma, carbon dioxide content and capacity, 191
- Vitamine, fat-soluble, 81, 149, 163, 549
- , —, content of green plant tissues together with some observations on their water-soluble vitamine content, 149
- , —, thermostability in plant materials, 163
- , water-soluble, distribution in plant tissues, 451
- , —, milk as a source, 515
- Volatility of indole from aqueous solution, influence of hydrogen ion concentration, 37
- WATER-** and fat-soluble vitamine content of green plant tissues, 149
- Water-soluble vitamine distribution in plant tissues, 451
- —, milk as a source, 515
- WELKER, WILLIAM H., and WILLIAMSON, CHARLES SPENCER.** Hemoglobin. I. Optical constants, 75
- WELLS, E. B.** See **HALVERSON** and **WELLS**, 205
- Wheat, barley, oat, and rye kernels, nutritive value of the proteins, 275
- WILLIAMSON, CHARLES SPENCER.** See **WELKER** and **WILLIAMSON**, 75
- WOODYATT, R. T.** An improved volumetric pump for continuous intravenous injections, 315
- WU, HSIEN.** See **FOLIN** and **WU**, 367
- YEAST** nucleic acid, properties of the nucleotides from, 483
- — —, structure, 19
- ZOLLER, HARPER F.** Influence of hydrogen ion concentration upon the volatility of indole from aqueous solution, 37
- , Quantitative estimation of indole in biological media, 25

PROCEEDINGS OF THE AMERICAN SOCIETY OF
BIOLOGICAL CHEMISTS.

THIRTEENTH ANNUAL MEETING.

Baltimore, Md., April 24-26, 1919.



DETERMINATION OF AMINO NITROGEN IN COMPOUNDS REACTING SLOWLY WITH NITROUS ACID.

BY D. WRIGHT WILSON.

(From the Laboratory of Physiological Chemistry, the Johns Hopkins
University, Baltimore.)

The rates of reaction of a number of compounds with nitrous acid were studied. Guanine, guanosine, and guanylic acid each give a quantity of gas equivalent to a considerable fraction more than one nitrogen in 1 to 2 hours at 22-25°. Adenine and adenine nucleotide each give exactly the equivalent of one nitrogen. Xanthine and hypoxanthine give off small quantities of gas but uric acid gives none. Cytosine reacts abnormally yielding 137 per cent of the calculated amount of gas in 3 hours. Uracil, thymine, and uridin do not react.

Allantoin reacts slowly and continuously giving off nearly two nitrogens in 5 hours. Substituted amino groups as found in betaine and sarcosine do not react. While creatine fails to give more than traces of gas in 30 minutes, creatinine reacts rapidly yielding gas equivalent to one nitrogen in 1 hour. The action of nitrous acid on creatinine may account for about one-third of the correction for "slowly reacting amines" met with in Van Slyke's determination of amino nitrogen in the urine. The rate of reaction of the various compounds varies considerably with the temperature.

GROWTH EXPERIMENTS WITH PHASEOLIN FROM THE NAVY BEAN.

BY C. O. JOHNS, A. J. FINKS, AND MABEL S. PAUL.

(From the Bureau of Chemistry, United States Department of Agriculture,
Washington.)

Nutrition experiments with phaseolin, the principal protein of the navy bean (*Phaseolus vulgaris*), show that this protein, after it is treated with dilute alkali and supplemented with 2

per cent of cystine, produces normal growth when it is the sole source of protein in an otherwise adequate diet. Further work is in progress to determine whether alkaline treatment of this protein is necessary for normal growth. The proteins of other beans are being studied in a similar manner.

HYDROLYSIS OF STIZOLOBIN.

BY D. BREESE JONES AND CARL O. JOHNS.

(From the Bureau of Chemistry, United States Department of Agriculture, Washington.)

Stizolobin, the principal protein extracted from the Chinese velvet bean, *Stizolobium nivum*, gave the following percentages of amino-acids on hydrolysis with 20 per cent hydrochloric acid: Glycine 1.66, alanine 2.41, valine 2.88, leucine 9.62, proline 4.00, phenylalanine 3.10, aspartic acid 9.23, serine 0.67, tyrosine 6.24, cystine 1.13, arginine 7.14, histidine 2.27, lysine 8.51, ammonia 1.55. Tryptophane was present. Tyrosine was determined both by the colorimetric method of Folin and Denis, and by direct isolation, the latter method giving 5.25 per cent. A method for the direct determination of proline is described, which consists in removing the bases from the hydrolysis solution by means of phosphotungstic acid, extracting the remaining dry, powdered amino-acids with boiling absolute alcohol. Both the total nitrogen and amino nitrogen in the extract are determined and the percentage of proline is calculated from the resulting data.

DETERMINATIONS OF THE HYDROGEN ION CONCENTRATION OF FOODS DURING STORAGE AND PREPARATION IN RELATION TO PRESERVATION OF ANTISCORBUTIC PROPERTIES.

BY J. F. McCLENDON AND PAUL F. SHARP.

(From the Physiological Laboratory, University of Minnesota Medical School, Minneapolis.)

The juices of green malt, carrots, cabbage, potatoes, turnips, and lean beef were all found to be distinctly acid whether fresh, or after cold storage, or after boiling in an open vessel. The

meat was first triturated in distilled water. The food was simply placed in a canvas bag, the bag placed in a Buchner press, and the juice pressed out. The juice pressed out of boiled food was acid and the juice boiled after pressing out of fresh food was acid. The unboiled preparations became more acid on standing but the boiled preparations were so constant as to indicate that their content of volatile acids or bases was very low.

All measurements were made with the hydrogen electrode in which a gold disc was coated with platinum or palladium black. Results with the disc coated with palladium or only partly immersed could not be duplicated. Results with platinum-coated discs entirely immersed were constant and could be duplicated. Apparently the acids attack palladium and the air-surface film has an abnormal hydrogen ion concentration and must not be near the platinum black coating.

Since antiscorbutic vitamins are sensitive to alkalis the results are encouraging. A malt extract intended to cure scurvy was found to be acid during all steps of preparation. Green malt was ground and mashed and at the end of 1 hour momentarily raised to 70°, and, after all the starch was hydrolyzed, condensed *in vacuo* to the point at which bacteria no longer attacked it.

FAILURE OF ACID-FORMING DIET TO CHANGE THE ALKALINE RESERVE OF DOG'S BLOOD.

By J. F. McCLENDON, OSCAR J. ENGSTRAND, AND FRANCES KING.

(From the Physiological Laboratory, University of Minnesota Medical School, Minneapolis.)

By titration in the rotating hydrogen electrode it was found that 0.0295 to 0.0300 cc. of normal HCl was required to neutralize 1 cc. of blood plasma on several normal dogs. A dog was fed on raw lean beef for about 2 months. Blood drawn from a vein at the end of 1 month and from the carotid at the end of 2 months and centrifuged without exposure to air was found to have the same alkaline reserve as the controls. The ash of the food would have required 1,500 cc. of normal KOH for neutralization. We believe that acid-forming diets may be detrimental because they may be deficient in vitamins. Cereals and meat (especially as usually cooked) are deficient in antiscorbutic vitamins. A raw meat diet seems to be sufficient for dogs or men.

RELATIVE LENGTH OF THE INTESTINE IS MORE IMPORTANT
THAN THE CHARACTER OF THE FOOD IN DETERMINING
THE HYDROGEN ION CONCENTRATION OF
INTESTINAL CONTENTS.

BY J. F. McCLENDON, LEO C. CULLIGAN, CARL S. GYDESEN,
AND FRANK J. MYERS.

(From the Physiological Laboratory, University of Minnesota Medical
School, Minneapolis.)

Working on the supposition that we attribute to Metchnikoff that flooding the intestine with soluble carbohydrate in the presence of lactic acid bacteria or *Bacillus acidophilus* should cause an increased hydrogen ion concentration of the ileum, we experimented on pups, dogs, cats, and rabbits. We found the ileum content of pups, dogs, and cats acid throughout the entire length and very little changed by changing the soluble carbohydrate (lactose or other sugar) content of the food. The duodenum and proximal part of the ileum of rabbits are acid but the ileum may become slightly alkaline near the cecum. This alkalinity was not prevented by adding lactose to the diet. On averaging the results of Long and Fenger¹ we conclude that the upper third of the ileum of hogs, calves, and lambs is slightly acid and averages 0.215 atmospheres of CO₂ tension and the lower third is neutral or slightly alkaline and averages 0.14 atmospheres of CO₂ pressure. Apparently the CO₂ generated by the action of the gastric contents on the pancreatic juice makes the reaction acid and this acidity is kept up in a short intestine by amino-acids. In a long intestine the CO₂ and amino-acids are largely absorbed before the cecum is reached and the reaction may become alkaline. If acid fermentation of sugars occurs the acids are absorbed so rapidly that they do not prevent the alkaline reaction in the long intestine of herbivora. By forced feeding with sugar a marked diarrhea may be produced and a slightly increased acidity result. The replacement of *Bacillus acidophilus* by *Bacillus coli* in the weaning of pups does not result in a marked lowering of the hydrogen ion concentration of the ileum.

¹ Long, J. H., and Fenger, F., *J. Am. Chem. Soc.*, 1917, xxxix, 1278.

FAT-SOLUBLE VITAMINE OF GREEN FOODS.

BY THOMAS B. OSBORNE AND LAFAYETTE B. MENDEL.

(From the Laboratory of the Connecticut Agricultural Experiment Station and the Sheffield Laboratory of Physiological Chemistry, Yale University, New Haven.)

Our evidence for the occurrence of fat-soluble vitamine in certain green foods,² which has hitherto been demonstrated only by the use of the food products as a whole in the diet can now be supplemented with experiments in which ether extracts of the plant tissues have proved similarly efficient. McCollum, Simmonds, and Pitz³ have stated that "ether extraction of plant tissues does not remove the substances essential for growth which is contained in butter fat." We have, however, obtained potent preparations as follows: Spinach leaves and young clover respectively, dried in a current of air at about 60°, were extracted with *u. s. p.* ether. The resultant green extract, yielding an oily residue equal to about 3 per cent of the dried plant, was evaporated upon starch. These preparations, fed in daily quantities equivalent to 1 to 2 gm. of the dried plant, promoted recovery and renewal of growth in rats declining on diets deficient in fat-soluble vitamine. Inasmuch as only 30 mg. per day of the ether extract of spinach sufficed for this purpose it appears that this product ranks among the most potent of the oils heretofore tested. The effects of spinach oil and clover oil in restoring growth in rats that had declined on a diet lacking the fat-soluble vitamine were exhibited in graphic charts of changes in body weight.

ARE THE ANTINEURITIC AND THE WATER-SOLUBLE B VITAMINES THE SAME?

BY A. D. EMMETT AND G. O. LUIROS.

(From the Research Laboratory of Parke, Davis and Company, Detroit.)

The chief point in this series of experiments was to study the effect of feeding the same basal food, natural brown rice, to *both* pigeons and young rats, and to determine the effect on the onset

² Osborne, T. B., and Mendel, L. B., *J. Biol. Chem.*, 1919, xxxvii, 187.

³ McCollum, E. V., Simmonds, N., and Pitz, W., *Am. J. Physiol.*, 1916, xli, 363.

of polyneuritis and on the rate of growth. The rice was the sole source of the water-soluble vitamine. It was supplemented, for the rats, so that the diet was complete in all other respects. The effect of heat on the water-soluble vitamine in the rice was the criterion for making the distinction.

It was found, upon heating the rice for 2 and 6 hours respectively in the autoclave at 15 pounds pressure, that the anti-neuritic vitamine was destroyed while the growth-promoting vitamine (water-soluble B) was not so altered. The rate of growth and the food intake varied inversely with the length of time of heating.

We took vitamine extracts of brewer's yeast, and activated fullers' earth vitamine preparations from yeast and protein-free milk, heated these in the same manner as the rice, and tried them out on rats and pigeons. Pigeons could not be cured of polyneuritis nor could the onset of the disease be delayed. Young rats that were suffering from the lack of the water-soluble B immediately began to grow. The possibility of toxic substances in the heated rice having thus been removed, the evidence seemed to be clear that these two vitamines were not one and the same as has been generally claimed. Further study is in progress to enable us to substantiate this hypothesis.

STABILITY OF LACTALBUMIN TOWARDS HEAT.

BY A. D. EMMETT AND G. O. LUROS.

(From the Research Laboratory of Parke, Davis and Company, Detroit.)

Since casein has been claimed to be susceptible to heat and also to be a better protein for growth than lactalbumin, the nutritive value of the latter was studied from the standpoint of its stability toward high temperature. Lactalbumin was heated in an air oven for 2 hours at 120°, and in an autoclave for 1, 2, and 6 hours respectively at 15 pounds pressure, temperature 120°. The heated protein was incorporated in a ration which was complete for normal growth in all respects. Control tests were carried out with lactalbumin that had been dried *in vacuo* at 55-60°. The amount of fat-soluble A (butter fat) was varied also ranging from 5 to 28 per cent.

It was found that heating had practically no effect upon the nutritive value of the lactalbumin even when heated for 6 hours in the autoclave. The higher amounts of butter fat rendered the rations more economical, that is, of the three groups of rats on the 2 hour autoclaved lactalbumin, fed respectively 5, 18, and 28 per cent fat, the 28 per cent fat diet made better gains per gm. of food than did the 5 per cent fat diet. The effect of heat appears to be due to the partial destruction of a water-soluble vitamine other than the growth-promoting accessory, water-soluble B.

NUTRITIONAL STUDIES ON GROWTH OF FROG LARVÆ (*RANA PIPIENS*).

BY A. D. EMMETT AND FLOYD P. ALLEN.

(*From the Research Laboratory of Parke, Davis and Company, Detroit.*)

Tadpoles soon after hatching were grouped and each lot of 500 was fed a definite diet which varied in respect to the kind and amount of protein, the kind and source of water-soluble and fat-soluble vitamins, the kind of carbohydrate, and the amount of fat. Detailed observations were made of the rate of growth (size) and development (length of hind legs). Experimental conditions were maintained exactly the same for all groups including the controls.

It was found that the quality of protein was a much more important factor than the amount; that both vitamins were essential, the water-soluble type being perhaps the more important; that dextrin was no more available than starch; and that the amount of fat present was a very important factor to be borne in mind—large amounts inhibiting both growth and development. In these preliminary studies, it was evident that some factor or factors other than those which were needed for normal growth and development of the rat was essential to the full, vigorous maturity of tadpoles.

DISTRIBUTION OF THE ANTINEURITIC VITAMINE IN THE WHEAT
AND CORN KERNEL.

BY CARL VOEGTLIN AND C. N. MYERS.

(From the Division of Pharmacology, Hygienic Laboratory, Washington.)

Feeding experiments on pigeons with corn and wheat, from which the portion containing the embryo had been eliminated, have shown that these foods are practically devoid of antineuritic vitamine. The pigeons developed polyneuritic symptoms after 3 to 4 weeks. Alcoholic extracts of the portion containing the germ, when administered to these polyneuritic pigeons, relieved the symptoms. When changed to an exclusive diet of whole wheat or corn the pigeons also recovered and remained healthy for weeks. It is therefore concluded that (1) the aleurone cells are not the seat of the antineuritic vitamine and (2) that this substance resides in the portion containing the germ and probably within the germ.

COMPARATIVE METABOLISM OF P-NITROPHENYLACETIC ACID.

BY CARL P. SHERWIN.

(From the Chemical Laboratory of Fordham University Medical School, New York.)

After the ingestion of *p*-nitrophenylacetic acid by a man, only the free acid could be found in the urine and none apparently existed in a conjugated form. 68.70 per cent of the acid fed was extracted from the urine.

After feeding the acid to a dog only 45 per cent of the amount fed was recovered from the urine. Of this amount, 30 per cent was excreted as free *p*-nitrophenylacetic acid while 15 per cent was combined with glycocholl and excreted as *p*-nitrophenaceturic acid.

A hen was fed small doses (1 gm. or less) of the *p*-nitrophenylacetic acid. Some of the free acid was extracted from the excreta, but most of the acid was found to be combined with ornithine. This compound on analysis gave results corresponding to the formula $C_{21}H_{22}N_4O_5$.

The acid is soluble in alcohol but insoluble in ether and cold water. The sodium and potassium salts were found to be very hygroscopic and in water solution were dextrorotatory.

The compound was hydrolyzed by boiling with 30 per cent HCl. *p*-Nitrophenylacetic acid was extracted with ether from this acid mixture and identified. The HCl solution remaining was evaporated *in vacuo*. The residue was made alkaline and shaken with benzoyl chloride, then acidified. Crystals of ornithinic acid appeared.

The compound isolated from the excreta of the hen is undoubtedly *p*-nitrophenacetornithinic acid, composed of 1 molecule of ornithine and 2 molecules of *p*-nitrophenylacetic acid.

NATURE OF THE TOXIC AGENT IN MEAT POISONING.

BY ISIDOR GREENWALD.

(From the Harriman Research Laboratory, the Roosevelt Hospital, New York, in Cooperation with the Section of Food and Nutrition, Medical Department, United States Army.)

Fresh beef was infected with cultures of *Bacillus paratyphosus* B, *Bacillus enteriditis*, etc. After standing for from 2 to 10 days, the organisms were killed by heating the jar containing the meat to 80° for 30 minutes. The meat was then fed, for from 6 to 8 days, to rats, mice, and guinea pigs. No ill effects were observed. Similar results were obtained with beef and veal condemned because of septicemia, etc. in the animal.

Precipitation by mercuric acetate cannot be employed for the isolation of methylguanidine. The precipitation is not complete and methylguanidine is formed by the oxidation of creatine. Using a method which is free from these objections, no methylguanidine could be isolated from either fresh meat or that which had been allowed to undergo several days bacterial decomposition. Added methylguanidine was recovered, quantitatively.

PRELIMINARY EXPERIMENTS OF THE INFLUENCE OF AMINO-ACID ON THE DIASTATIC HYDROLYSIS OF STARCH.

BY H. C. SHERMAN AND FLORENCE WALKER.

(From Columbia University, New York, and Carnegie Institution of Washington, Washington.)

Wheat, maize, and rice starches, similarly purified, showed equal digestibility or rate of diastatic hydrolysis. This was true whether the enzyme employed was purified pancreatic amylase,

commercial pancreatin, saliva, purified malt amylase, malt extract, purified amylase of *Aspergillus oryzae*, or commercial taka-diastrase. With all these except purified pancreatic amylase, potato starch showed a rate of hydrolysis equal to or slightly greater than that observed with the cereal starches. The tendency to abnormally low results in the case noted can be corrected by the addition either of a boiled, carefully neutralized, water extract of potato, or neutralized aspartic acid. Neutralized aspartic acid also increased the rate of transformation of all four of the starches tested, when the enzyme employed was purified pancreatic or malt amylase, commercial pancreatin, or saliva, but did not influence the rate of action of malt extract or taka-diastrase. It was demonstrated electrometrically that the neutralized amino-acid added in these experiments was without effect upon the hydrogen ion concentration of the digestion mixture. The experiments are being continued and extended to other amino-acids and acid amides.

A CORRELATION ON THE OCCURRENCE OF THE FAT-SOLUBLE VITAMINE.

By H. STEENBOCK, P. W. BOUTWELL, AND HAZEL E. KENT.

(From the Laboratory of Agricultural Chemistry, University of Wisconsin, Madison.)

In the generalizations sometimes indulged in, when evaluating naturally occurring foodstuffs for specific dietary properties, there has been a tendency to associate a high concentration of the vitamins with the metabolically more active tissues. While this may have been justifiable in certain instances, yet such teleological reasoning may lead to conclusions far from the truth. This has been brought out in experiments carried out to determine the fat-soluble vitamin content of tubers and roots. Presumably all tubers and roots function in the capacity of storage organs for the storage of materials necessary for nursing the growth of the following year's sprouts, yet among them there is a tremendous variation in the fat-soluble vitamin content. This is of such an order that it cannot be correlated with difference in amount of growing tissues. However, there appears to be some relation between yellow pigmentation and vitamin content.

Sweet potatoes and carrots, both highly pigmented, are very rich in the fat-soluble vitamine, while Irish potatoes, mangels, dash-eens, and sugar beets, all carrying little or no pigment, are poor in it. Somewhat similar relations obtain with maize, although it is not as yet justifiable to state it as a general principle. On sound kernels of white maize, suitably supplemented with protein and salts, it has been found impossible to keep young rats alive longer than a few months—death usually resulting after xerophthalmia had set in. On the other hand, on yellow maize, under the same experimental conditions, young rats have grown to maturity at the normal rate, have maintained themselves in excellent condition for months, and have reproduced repeatedly. It is certain that maize, as one of our cereal grains, is by no means always as deficient in the fat-soluble vitamine as present day statements in current contributions would lead one to believe. It is possible that these observations of pigment and vitamine content may give a clue to the manipulations necessary in a procedure leading to the isolation of the fat-soluble vitamine. It is not meant to infer that the vitamine is necessarily a colored compound, but its association with yellow plant pigments is suggestive of its possible chemical nature. It is not carotin.

ON THE PROBLEM OF THE PRODUCTION OF FAT FROM PROTEIN IN THE DOG.

BY H. V. ATKINSON AND GRAHAM LUSK.

*(From the Physiological Laboratory of Cornell University Medical College,
New York.)*

In eight experiments in a series of thirteen, after giving meat in large quantities (700 to 1,300 gm.) to a dog weighing 11 kilos, the respiratory quotients during the height of protein metabolism were between 0.793 and 0.800. A calculation showed that under these conditions the retained carbon residue of the protein metabolized was held back in such a form that, had it been oxidized, the respiratory quotient of this retained pabulum would have been 0.85. This would represent the oxidation of material half of whose calories were composed of fat and half of carbohydrate. The dog showed quotients of 0.82 and above only after the larger quantities of meat were given (1,000 gm. or more). It was

extremely difficult to induce the dog to take meat in sufficient quantity to indicate a considerable production of fat from protein. Incidentally it was observed that the basal metabolism of a dog fed with meat in large quantity for a time and then caused to revert to a standard diet (meat, 100 gm.; lard, 20 gm.; and biscuit meal, 100 gm.) remained persistently (even after 2.5 weeks) at a higher level than had obtained prior to the meat ingestion. This confirms F. G. Benedict's idea of a higher basal metabolism in the presence of "surplus" cellular nitrogen, or the "improvement quota" of protein according to Rubner's terminology.

NOTE ON THE COLORIMETRIC DETERMINATION OF LACTOSE.

By JOSEPH BOCK.

(From the Department of Physiological Chemistry, Marquette School of Medicine, Milwaukee.)

The reaction of lactose with picric acid was studied. The procedure used is similar to the one used by S. R. Benedict in the colorimetric determination of dextrose. The lactose is hydrolyzed before being heated with picric acid and sodium carbonate. The unhydrolyzed lactose gives less uniform results and less intense color development.

The lactose in milk is being determined by this method. After hydrolyzing the lactose, the milk proteins are removed by precipitation with picric acid. An aliquot of the filtrate is used for the lactose determination. 1 cc. or less of milk is used.

Details of the procedure will be published in the near future. The reaction of other carbohydrates with picric acid is being studied.

URINARY OUTPUT OF NITROGEN, CHLORINE, CALCIUM, AND MAGNESIUM IN DIABETES MELLITUS.

By C. FERDINAND NELSON.

(From the Laboratory of Biological Chemistry, University of Kansas, Lawrence.)

Determinations of calcium, magnesium, and sodium chloride in nineteen cases of diabetes mellitus show variations as follows:

Calcium (metal).....	100- 791 mg.
Magnesium "	88-1,049 "
Sodium chloride.....	1.7-15.83 gm.

The total nitrogen varied from 4.58 to 18.40 gm.

Magnesium was excreted in amounts larger than calcium in 26 per cent of the cases studied.

Eleven determinations, made from 5 to 21 days after six of the above cases had been rendered free from sugar, showed a striking change in the urinary calcium and magnesium ratio, magnesium appearing in larger amounts than calcium in 72 per cent of the determinations.

The total nitrogen in each of the latter cases was from 1 to 6 gm. higher than in the former.

CALCIUM AND MAGNESIUM CONTENT OF NORMAL URINE. II.

BY C. FERDINAND NELSON.

(From the Laboratory of Biological Chemistry, University of Kansas, Lawrence.)

Additional determinations of the urinary output of calcium and magnesium in normal men and women, on mixed diets in no way restricted or modified except by appetite, show in 58 cases (41 men and 17 women) extreme variations of calcium and magnesium as follows:

			<i>mg.</i>
Calcium	(metal)	{	Men..... 416-87
			Women..... 265-28
Magnesium	"	{	Men..... 305-30
			Women..... 166-39

Calcium occurs in larger amounts than magnesium in urine in from 74 to 84 per cent of all determinations made in this laboratory. Magnesium predominates in from 16 to 24 per cent.

Analyses of 3 hour samples of urine, in cases where the magnesium output exceeds that of calcium, show a constant preponderance of the former element throughout the periods observed.

The nitrogen output in cases where magnesium exceeds calcium in the urine is quite as high or may be even higher than where calcium is excreted in the larger amount.

The ingestion of calcium-rich foods, such as milk, promptly increases both the urinary calcium and magnesium outputs.

AVERAGE FOOD CONSUMPTION IN TRAINING CAMPS OF THE
UNITED STATES ARMY.

By JOHN R. MURLIN,

*Lieutenant Colonel, Sanitary Corps, U. S. Army.**(From the Division of Food and Nutrition, Medical Department, United States Army.)*

A comparison was shown of the various rations of the Allied armies, those used in the training period, and those used in active campaign. The average food consumption in 427 messes scattered over 67 different camps including forty-nine divisional and other large concentration camps, fourteen aviation fields, three war prison barracks, one recruiting station, and one spruce production camp is 3,633 calories. The weighted average amounts to 3,625 calories. To this must be added the average food consumption from the canteen or post exchange. Studies in 261 post exchanges in these camps disclose an actual average *per capita* consumption of 365 calories daily. This makes a total food consumption for the average soldier in training of in round numbers 4,000 calories (3,998). Averages by months indicate a well marked, though slight, seasonal variation. The same is shown also when the various messes studied are arranged according to the average prevailing temperature at the time of the surveys.

As compared with the consumption in civilian households the army uses more than twice as much fresh meat, beans, and dried fruit, one and a half times as much bread and bakery products and potatoes, the same amount of sugar, eggs, and lard, much less fresh vegetables, fresh fruits, butter, and milk.

Of the 4,000 calories consumed by the average soldier in heavy training 13 per cent is protein, 31 per cent fat, and 56 per cent carbohydrate. Neglecting the canteen consumption, the distribution is 14 per cent protein, 31 per cent fat, and 55 per cent carbohydrate. As compared with civilian dietaries the percentage of protein is higher, the percentage of fat about the same, and the percentage of carbohydrate a little less.

The average recruit on this diet has gained nearly 7 pounds in a period of 5 months training; the gain is evenly distributed over men of different initial weight.

VARIATIONS IN STRENGTH AND IN THE CONSUMPTION OF
FOOD BY RECRUITS AND BY SEASONED TROOPS.

BY PAUL E. HOWE.

*Captain, Sanitary Corps, U. S. Army.**(From the Section of Food and Nutrition, Medical Department, United States Army.)*

Determinations were made of the variations in strength, using the Martin strength test (by Lieut. C. C. Mason), and weight of approximately forty men from each of eight companies of recruits. The studies extended for 3 consecutive weeks; a smaller number of men were studied for 4 weeks. Weights and strength were determined at 7 day intervals. The food consumption of the companies from which the men were taken was determined (by Lieut. S. C. Dinsmore) in weekly periods. In each period one group of four companies used the same menu and the other four companies a different menu but applicable to all four companies. The men were inoculated and vaccinated during the first 2 weeks of study.

In the first test the men had an average strength which was rather high grade for civilians according to Martin's classification (low B), 757 lbs. Both strength and weight had decreased on the average at the second test: weight, 145.7 to 144.7 lbs., strength, to 705 lbs. The third test indicated that the men had returned approximately to normal: weight, 146.3 lbs.; strength, 743 lbs. The men tested the fourth time maintained their status of the 3rd week or increased slightly in both weight and strength. Conflicting values were obtained with regard to the relation of the proximity of the inoculation to the succeeding strength test. The changes in weight agree with those obtained by Lieut. Perlzweig in another camp.

The average consumption of food for all the companies shows a decrease in the 2nd week from 3,436 to 3,248 calories per man per day; the following week there was an increase to 3,542 calories. One of the two groups of four companies showed a gradual decrease in food consumption while the other showed a regular increase. The food ingestion of different groups of men using the same menu showed considerable variations in quantity and the same group of men have a tendency to vary in the quantity of

food consumed on the basis of the weekly average consumption. These variations are apparently not related to weather changes. The variation in food consumption of seasoned troops, four companies, over a period of 4 weeks likewise showed considerable variation. In each comparative case the men were doing approximately the same work.

**EFFECT OF INTRAVENOUS INJECTION OF PANCREAS EMULSION
UPON THE HYPERGLYCEMIA DUE TO DEPANCREATIZATION.**

By ISRAEL S. KLEINER.

(From the Department of Physiology and Pharmacology of The Rockefeller
Institute for Medical Research.)

4 years ago, in the course of another investigation, Kleiner and Meltzer⁴ found that an intravenous infusion of pancreas emulsion into depancreatized dogs temporarily reduced the blood sugar in a marked degree—sometimes to a normal level. The three experiments of that report have now been increased to sixteen, with results which confirm the preliminary statement.

The pancreatic emulsion was prepared as follows: Fresh dog's pancreas was hashed and mixed with three or four times its weight of sterile distilled water. After from 1 to 20 hours in the refrigerator it was strained and squeezed through muslin. The fluid was then mixed with five volumes of sterile 0.9 per cent NaCl solution and was injected slowly during the course of about an hour. The injection of this unfiltered faintly acid or neutral fluid caused a marked reduction of the sugar content of the blood (a loss of 0.09 to 0.20 per cent) in ten experiments, while in six the fall was less pronounced (0.02 to 0.07 per cent). For example, in two experiments the glycemia fell from 0.28 to 0.08 per cent and from 0.33 to 0.17 per cent, respectively. The fall began during the injection and reached its maximum 1 or 2 hours after the injection was ended. There was no dilution of the blood.

A reduction in glycosuria also occurred, but this was produced also by emulsions of other organs. These, however, have not produced the above effect on the blood sugar.

⁴ Kleiner, I. S., and Meltzer, S. J., *Proc. Nat. Acad. Sc.*, 1915, i, 338.

**OXIDATION OF LUCIFERIN AND REDUCTION OF OXYLUCIFERIN
OF LUMINOUS ANIMALS.**

BY E. NEWTON HARVEY.

(From the Physiological Laboratory, Princeton University, Princeton.)

Some luminous animals are known to produce their light by the oxidation of a substance called luciferin in the presence of a second substance called luciferase. Luciferase has many characteristics of an enzyme but is slowly used up in oxidizing large quantities of luciferin. A third substance, photophlein, may assist the luciferin-luciferase reaction. In the absence of luciferase, luciferin oxidizes spontaneously but without light production. The oxidation product may be called oxyluciferin. The reaction $\text{luciferin} \rightleftharpoons \text{oxyluciferin}$ is similar to the reaction $\text{leucomethylene blue} \rightleftharpoons \text{methylene blue}$, as the oxyluciferin can be reduced to luciferin again by Schardinger's enzyme of milk or the reductases of animal tissues. Oxyluciferin can also be reduced by H_2S , nascent hydrogen (from Mg powder and acid), by finely divided palladium, and sodium hypophosphite. Dilute acid favors the reduction and dilute alkali favors the oxidation change. Contrary to the opinion of most investigators no extensive oxidative change appears to occur during luminescence and no carbon dioxide is formed.

**ENZYME STUDIES ON DEHYDRATED AS COMPARED WITH FRESH
VEGETABLES.**

BY K. GEORGE FALK, GRACE MCGUIRE, AND EUGENIA BLOUNT.

(From the Harriman Research Laboratory, the Roosevelt Hospital, New York, in Cooperation with the Section of Food and Nutrition, Medical Department, United States Army.)

Oxidase, peroxidase, catalase, and amylase were determined in fresh and dehydrated potatoes, tomatoes, cabbage, yellow and white turnips, and carrots. In general, the enzyme actions were decreased on dehydration, more so by air blast dehydration than by vacuum dehydration. The effects of hydrogen ion concentrations on the actions were studied. The potato amylase apparently acted differently on the starch occurring naturally in potato juice than it did on Lintner prepared starch.

THE WORK OF THE HARRIMAN RESEARCH LABORATORY IN
AFFILIATION WITH THE DIVISION OF FOOD AND
NUTRITION, MEDICAL DEPARTMENT,
UNITED STATES ARMY.

BY K. GEORGE FALK.

(From the Harriman Research Laboratory, the Roosevelt Hospital, New York, in Cooperation with the Division of Food and Nutrition, Medical Department, United States Army.)

The work was divided into three parts: study of meat, including chemical study of spoilage⁵ and toxicity studies; development of new process of dehydration applicable to all food products including meat and fish; comparative study of enzymes, proteins, and carbohydrates of fresh vegetables and vegetables dehydrated by different processes.

CHEMICAL CHANGES IN THE BLOOD IN ADVANCED NEPHRITIS.

BY VICTOR C. MYERS AND JOHN A. KILLIAN.

(From the Laboratory of Pathological Chemistry, New York Post-Graduate Medical School and Hospital, New York.)

As is now well known, the blood in cases of advanced (interstitial) nephritis is characterized by a marked increase in all the compounds which go to make up the non-protein nitrogen. Of the three waste products, uric acid, urea, and creatinine, creatinine appears to be most readily eliminated by the kidney, and is therefore the last one to be retained in nephritis. For this reason and also because of its endogenous origin and very constant formation, the kidney is apparently never able to overcome the handicap of a high creatinine accumulation, thus making creatinine a most valuable prognostic test. Of 85 cases having a creatinine of over 5 mg. per 100 cc. of blood (figures up to 33 mg.) 80 have died, three remain unchanged, while two acute cases have recovered (figures of 5.6 and 6.1 mg.). The question naturally arises whether creatinine may not be responsible for some of the terminal symptoms as a result of its conversion to methylguanidine, a point which has not yet been definitely answered.

⁵ Falk, K. G., Baumann, E. J., and McGuire, G., *J. Biol. Chem.*, 1919, xxxvii, 525. Falk, K. G., and McGuire, G., *J. Biol. Chem.*, 1919, xxxvii, 547.

In connection with convulsive symptoms it may be noted that low figures for Ca may be found; we have observed figures as low as 3 to 4 mg. per 100 cc. of blood.

Judging from the first twenty cases in the above series, in which CO₂ estimations were made, severe acidosis is an invariable accompaniment of advanced nephritis, the CO₂ in twelve instances being low enough to afford an explanation of coma and death.

ELIMINATION OF TARTRATES.

By GEORGE ERIC SIMPSON.

(From the Department of Experimental Medicine, School of Medicine, Yale University, New Haven.)

The urinary elimination of dextro tartaric acid was studied after the sodium salt was given subcutaneously or by stomach tube to cats, dogs, and rabbits. The method used for the determination of tartrate was the Halenke and Moeslinger procedure, which involves the titration of precipitated potassium acid tartrate with standard alkali. This method was found to give consistent results when applied to urine.

After subcutaneous administration, tartrate is eliminated in the urine of all species studied in practically the same degree. Between 70 and 90 per cent of tartrate was found in the urine. When successive subcutaneous injections were given without the development of tolerance the amount of tartrate excreted after each injection decreased until finally none was excreted and the animals died.

When tartrate was given to rabbits or dogs by mouth less was eliminated by the kidneys than after subcutaneous administration. In rabbits an average of 4.9 per cent, in dogs an average of 23.9 per cent, of the tartrate administered by stomach tube was found in the urine. It seems hardly possible that tartrates are oxidized within the body. That part which passes the intestinal wall is for the most part excreted unchanged in the urine.

Calcium administration was not found to delay the excretion of tartrate or alter the degree of elimination by the kidneys. Thus calcium precipitation is probably not a factor in tartrate nephritis.

We were unable to recognize any marked effect of diet on the urinary excretion of tartrates, or to explain, by our study, the marked effect of diet on toxicity reported by Salant and his coworkers.

CHEMICAL IDENTIFICATION OF THE THYROID HORMONE.

By E. C. KENDALL.

(From the Section of Biochemistry, Mayo Foundation, Rochester.)

The iodine-containing compound which occurs in the thyroid was isolated in crystalline form at the end of the year 1914. Its empirical and structural formulas were determined in May, 1917, and now its synthesis, which has recently been accomplished, completes the chemical work involved in this present investigation. Its chemical structure is related to that of tryptophane, from which it is probably derived. The compound has been named thyro-oxy-indol which has been abbreviated to thyroxin. The data concerning its formula and derivatives were given and the active groups in the molecule CO-NH were discussed. The iodine in the molecule which is attached to the benzene ring does not appear to be involved when the substance affects the energy output, but the chemical groups responsible for its activity are the CO-NH groups which in the body change their form to amino carboxyl groups and the substance, in all probability, functions in this form. The change from CO-NH to amino carboxyl is precisely similar to the opening of the creatinine ring with the formation of creatine. Thyroxin, therefore, although not an α -amino-acid, is essentially an amino-acid and it falls into the well known fundamental groups of substances: amino-acids, protein, creatinine, creatine, etc.

Thyroxin can exist in three forms. The structural formulas are as follows:

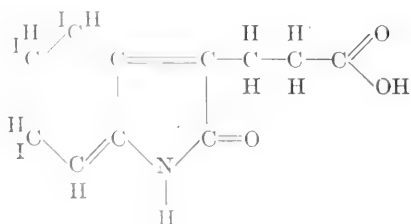

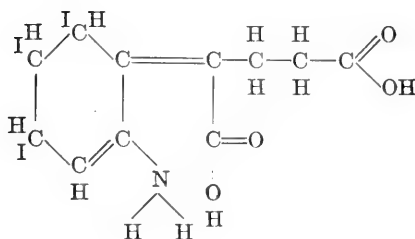
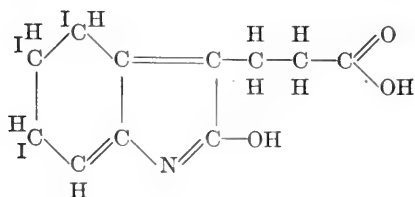

DETERMINATION OF ACETONE IN EXPIRED AIR.

By ROGER S. HUBBARD.

(From the Laboratory of Clifton Springs Sanitarium, Clifton Springs.)

A method was described for determining quantitatively acetone in the expired air. Acetone was collected in dilute solution of sodium bisulfite. The subject breathed directly through two bottles containing a 2.5 per cent solution. It was transferred to a Kjeldahl flask and distilled from sulfuric acid and excess potassium permanganate. It was then redistilled from sodium peroxide into Scott-Wilson reagent, and determined by comparing the turbidity with that produced by known amounts of acetone freshly distilled into the same reagent. Solutions of pure acetone added to the breath or to a stream of carbon dioxide gave 90 to 100 per cent recovery.

Normal excretion of acetone per hour as determined by this method ranged from 0.12 to 0.60 mg. and was considerably affected by the diet. Cases showing acidosis gave considerably higher values.

**DIRECT DETERMINATION OF THE NON-AMINO NITROGEN IN
HYDROLYZED PROTEINS.**

BY ALMA HILLER.

(From the Laboratories of The Rockefeller Institute for Medical Research.)

The former method used by Van Slyke in determining the non-amino nitrogen in hydrolyzed proteins was an indirect one, calculated by subtracting the amino nitrogen from the total nitrogen of the amino-acids. The present method determines this nitrogen directly by employing the following four steps:

1. The removal of phosphotungstic acid from the solution by means of an amyl alcohol-ether mixture, shaking in a separatory funnel, which completely removes the phosphotungstic acid.

2. The removal of the amino nitrogen by means of nitrous acid, in the presence of 10 per cent hydrochloric acid, and by the aid of heat.

3. The removal of the nitrous acid introduced into the reaction by means of reduction with zinc-copper couple.

4. The determination of the remaining or non-amino nitrogen by means of the Kjeldahl method.

**INFLUENCE OF TEMPERATURE ON THE ANTISCORBUTIC
VITAMINE IN TOMATOES.**

BY MAURICE H. GIVENS AND HARRY B. McCLUGGAGE.

(From the Department of Physiology, University of Rochester, Rochester.)

Experiments have been conducted to determine the effect of heat upon the value of tomatoes as an antiscorbutic agent. A daily supplement of 2.5 gm. of fresh raw tomatoes will protect a guinea pig from experimental scurvy when that animal is fed a scurvy-producing diet which is otherwise adequate. If fresh tomatoes are heated at 100°C. for 15 minutes or longer a larger daily dosage must be supplied to insure the animal protection against the disease.

Tomatoes canned according to the usual method of processing, heating under 5 pounds pressure for 10 minutes, will prevent scurvy in a guinea pig when fed in daily portions of 10 gm. This quantity is also sufficient for protection even after heating at 15 pounds pressure for 30 minutes.

Tomatoes dried at 35–40°C. for 32 to 52 hours will protect a guinea pig against experimental scurvy when fed in a daily amount of 0.5 gm. However, this dosage must be increased if the dried tomatoes are cooked before feeding.

The results obtained indicate that the tomato is a very efficient antiscorbutic agent. Further, there is some reduction in its antiscorbutic potency if it is subjected to certain temperature treatments.

THE ISOELECTRIC POINT OF VEGETABLE PROTEIN.

By E. J. COHN.

(From the Harriman Research Laboratory, the Roosevelt Hospital, New York, in Cooperation with the Division of Food and Nutrition, Medical Department, United States Army.)

The chief protein constituent of the potato—tuberin—was studied in connection with an investigation conducted by the Division of Food and Nutrition of the Surgeon General's Office upon the nature of the proteins in certain vegetables. The isoelectric point of tuberin was determined by the method of cataphoresis, and found to coincide with a slightly smaller hydrogen ion concentration than $10^{-4} \times$. At less acid and at neutral reactions, the protein ionized as anion and migrated to the anode in an electric field. Only at hydrogen ion concentrations greater than $10^{-4} \times$ did the direction of migration change and tuberin ionize as cation.

The effect of sodium chloride upon the solubility of tuberin at different hydrogen ion concentrations illustrates the significance of the isoelectric point. Only at the isoelectric point has sodium chloride no effect upon the solubility of tuberin. At greater acidities, the solubility was decreased by an increase in the concentration of sodium chloride. At neutral reactions sodium chloride increased the solubility of tuberin, which has therefore always been classified as a globulin.

The addition of sodium chloride also has an effect upon the apparent hydrogen potential of otherwise identical systems containing either tuberin and an acid or tuberin and a base. The addition of sodium chloride caused the reaction to converge upon a definite acidity. The addition of salt allows protein to combine

with more acid or more alkali at the same pH everywhere but at the isoelectric point. Previously published data upon gluten claim that gluten exhibits this phenomenon as did tuberin prepared by precipitation at the isoelectric point. Tuberin prepared by dialysis differed in its behavior in that the acidity of systems containing it occasionally converged upon another reaction, characteristic of the method of preparation. Under these circumstances, changes in solubility of the tuberin preparation accompanied those in reaction. These methods of investigation have also been employed in the study of the carrot and the tomato.

COMPOSITION OF BOG BUTTER COMPARED WITH THAT OF ADIPOCERE.

By R. F. RUTTAN AND L. ISOBEL HOWE.

(From the Department of Chemistry, McGill University, Montreal.)

Eight specimens of bog butter obtained from the Royal Irish Academy of Dublin and seven samples from the Belfast Public Art Museum were analyzed. In Table I will be found the physical and chemical constants of these specimens as compared with those of a very mature sample of pig's adipocere.

The analysis showed:

1. That the hydrolysis of the fats is not so complete in the bog butter as in the adipocere and the percentage of unsaturated fat acids is larger in the bog butter.

2. That the two hydroxy stearic acids which were found by the authors to be present in all samples of adipocere were also found in every sample of the fifteen examined, the average proportion being similar to that found in mature adipocere.

The specimens of bog butter will be seen to vary greatly among themselves in their general composition but like adipocere they have a higher melting point than the original fat and consist essentially of palmitic acid mixed with the two hydroxy stearic acids and a variable but small quantity of oleic acid and fats. Two specimens gave traces of volatile fat acids. Unlike adipocere, soaps were usually absent; traces only were found in one or two specimens.

The theta- and iota-hydroxy stearic acids may be considered characteristic of all "fossil fats."

TABLE I.

Physical and Chemical Constants of Bog Butter Compared with Those of Mature Pig's Adipocere.

	Mature pig's adipocere.	Bog butter.		
		Minimum.	Maximum.	Average of 15 specimens.
Specific gravity (100°C.).....	0.8436			0.8432
Soluble in ether.....	94.1	94.2	98.85	97.25
Melting point, °C.....	60.5	46.0	53.5	49.8
Refractive index at 55°C.....	1.4324	1.4377	1.4463	1.4420
Acid value.....	201.7	153	203.2	173.8
Saponification value.....	270.0	178	218	207.4
Volatile acids, <i>per cent.</i>	None.	None.	0.58	
Hydroxy stearic acids, <i>per cent.</i>	15.80	7.2	25.4	15.21
Neutral fats, <i>per cent.</i>	1.37	6.5	25.8	15.3
Iodine value.....	6.04	7.4	18.2	13.44
Acetyl "	34.75			22.71

THE DETERMINATION OF AMMONIA IN THE BLOOD WITH THE AID OF PERMUTIT.

BY S. MORGULIS AND M. JAHR.

TITRATION OF THE BICARBONATE IN BLOOD PLASMA.

BY DONALD D. VAN SLYKE AND EDGAR STILLMAN.

DEHYDRATED VEGETABLES FOR ARMY USE.

BY S. C. PRESCOTT.

THE ACTION OF ANTAGONISTIC ELECTROLYTES ON THE CONDUCTIVITY OF EMULSIONS AS COMPARED WITH PROTOPLASM.

BY G. H. A. CLOWES AND F. WEST.

APPLICATION OF THE PRINCIPLES OF NUTRITION IN AN ARMY CAMP.

BY R. J. ANDERSON.

THE ARMY RATION IN FRANCE.

BY PHILIP A. SHAFFER.

MILITARY HOSPITAL DIETARIES.

BY R. G. HOSKINS.

THE ACID-BASE BALANCE OF FOOD CONSUMED IN ARMY CAMPS.

BY N. R. BLATHERWICK.

A PHYSICO-CHEMICAL METHOD OF CHARACTERIZING
PROTEINS.

BY L. J. HENDERSON AND E. J. COHN.

ON THE CHEMICAL CONSTITUTION OF YEAST NUCLEIC ACID.

BY WALTER JONES.

ARGININE AND ARGINASE IN THEIR RELATION TO THE PRO-
DUCTION OF CREATINURIA.

BY H. STEENBOCK, E. D. GROSS, AND A. KOEHLER.

THE DETERMINATION OF NITROGEN IN DROP QUANTITIES OF
BLOOD BY DIRECT NESSLERIZATION.

BY AMOS W. PETERS.

THE FUNCTIONAL CAPACITY OF THE KIDNEYS AND THE BLOOD
FINDINGS IN LATE CASES OF "TRENCH NEPHRITIS."

BY A. P. LOTHROP AND W. T. CONNELL.

PROCEEDINGS OF THE AMERICAN SOCIETY OF
BIOLOGICAL CHEMISTS.

FOURTEENTH ANNUAL MEETING.

Cincinnati, Ohio, December 29-31, 1919.



THE ETIOLOGY OF RICKETS.

By E. V. McCOLLUM, NINA SIMMONDS, AND HELEN T. PARSONS.

(From the Laboratory of Chemical Hygiene, School of Hygiene and Public Health, the Johns Hopkins University, Baltimore.)

We have conducted an extensive series of experiments with rats restricted to diets derived from cereals and legume seeds; cereals, legume seeds, and muscle meats; and with similar diets in which degerminated products of cereal grains replaced whole seeds; and have supplemented these mixtures with purified food substances to determine the nature and extent of their dietary shortcomings.

In these experiments we have observed the gross picture of rickets in many of the animals restricted to faulty diets, and have demonstrated that this condition develops on diets in which the faults lie in several different factors.

A low content of fat-soluble A, low calcium content, poor quality of protein, and unsatisfactory salt combinations, acting in combinations; may all contribute to the etiology of the disease. We have not yet completed our observations on diets in which but a single factor is at fault. It is certain that specific fasting for fat-soluble A cannot be regarded as the sole and only possible cause of rickets.

Since the same gross picture can be induced in several different ways, we are led to suggest the possible occurrence of more than one kind of rickets. Histological studies of tissues of animals suffering from what appears to be rickets, but from different causes, are still in progress. No decision can yet be reached as to whether in all cases the histological picture is the same in animals exhibiting beaded ribs, enlargements of the costochondral junctions, deformity of the thorax, and general deformity of the body, irrespective of the dietary factor or factors which brought about the condition.

**THE RÔLE OF FAT-SOLUBLE VITAMINE IN HUMAN NUTRITION
AND ITS SUGGESTED RELATION TO RICKETS.**

BY ALFRED F. HESS.

(From the Bureau of Laboratories, Department of Health, New York.)

It has been shown that the fat-soluble vitamine is an essential constituent of the dietary of rats. There have also been clinical reports attributing marked malnutrition in infants and children to a lack of this dietary factor (Japan, Denmark). As a result of these experiences it has been accepted that this vitamine is highly important for man, and that the lack of it leads to nutritional disorder in children. This has been emphasized all the more as this vitamine is not nearly so widely distributed in nature as is the water-soluble vitamine. In order to study this question five infants, varying in age from 5 to 12 months, were given a diet which was complete except for a very small amount of fat-soluble vitamine. It consisted of 180 gm. daily of highly skimmed milk ("Krystalak" 0.2 per cent fat), 30 gm. of cane sugar, 15 to 30 gm. of autolyzed yeast (to supply water-soluble vitamine), 15 cc. of orange juice, 30 gm. of cottonseed oil, and cereal for the older infants.

On this diet the children have done well for a period of 8 to 9 months. They have shown no anemia, no eye trouble, no bone changes, as seen by the x-ray, nor has their growth in length or in weight suffered. We believe, therefore, that either a very small amount of this vitamine suffices to supply the needs of human nutrition, or that this deficiency has to be maintained for a period of years in order to bring about any harmful result. Danger from a lack of this dietary factor need not be apprehended if the diet is otherwise complete.

The development of rickets has been attributed by Mellanby, as a result of experiments on dogs, to a lack of fat-soluble vitamine, and Hopkins and Chick have termed this vitamine the "anti-rachitic factor." It was found, however, that infants fed on this "fat-soluble vitamine minimal diet" did not develop the well established signs of rickets—beading of the ribs, enlargement of the epiphyses, weakness of the muscles, etc. We cannot believe, therefore, that rickets is brought about merely by a deficiency of this principle; all the more so, as this disorder de-

veloped in infants receiving large quantities of milk containing ample fat-soluble vitamine. It may be added that neither cream nor the leafy vegetables, both of which are rich in this principle, are comparable to cod liver oil as growth stimulants.

PRELIMINARY OBSERVATIONS ON THE RELATION OF BACTERIA TO EXPERIMENTAL SCURVY IN GUINEA PIGS.

BY MAURICE H. GIVENS AND GEORGE L. HOFFMANN.

(From the Research Laboratories, Western Pennsylvania Hospital, Pittsburgh.)

Whether or not bacteria play any rôle in the development of scurvy in guinea pigs has not been settled by direct evidence. Jackson and Moore¹ found coccus-like bodies in microscopic sections of lesions in scorbutic guinea pigs. Jackson and Moody² isolated from the diseased joints, muscles, and lymph glands of these animals Gram-positive and Gram-negative organisms. Pure strains of these bacteria introduced into guinea pigs gave rise in most instances to hemorrhagic and other lesions in the bones, joints, muscles, lymph glands, and organs. Torrey and Hess³ concluded that scurvy, both of guinea pigs and of infants, was not associated with an overgrowth of putrefactive bacteria in the intestinal tract.

We have attempted to throw further light upon the question by bacteriological examinations of the blood, joints, and feces of guinea pigs made scorbutic on different diets and then treated with different antiscorbutic foods. Blood from scorbutic animals anesthetized and from those dying of the disease regardless of the diet producing the same has been found to be sterile. The enlarged front joints of guinea pigs developing scurvy on oats alone were sterile; this was likewise true in the majority of cases of guinea pigs developing scurvy on the soy cake food of Givens and Cohen.⁴ However, in two or three instances a staphylococcus and diplococcus were isolated. Pure strains of these organisms

¹ Jackson, L., and Moore, J. J., *J. Infect. Dis.*, 1916, xix, 510.

² Jackson, L., and Moody, A. M., *J. Infect. Dis.*, 1916, xix, 511.

³ Torrey, J. C., and Hess, A. F., *Proc. Soc. Exp. Biol. and Med.*, 1917-18, xv, 74.

⁴ Givens, M. H., and Cohen, B., *J. Biol. Chem.*, 1918, xxxvi, 127.

injected intracardially, intraperitoneally, and into the joints of healthy guinea pigs on a mixed diet produced no signs of scurvy. Smears and cultures were made of material from different parts of the intestinal tract of guinea pigs on oats alone, on oats plus lemon juice, 3 cc. daily, after scurvy developed, on the soy cake diet, and on the same plus cabbage after the appearance of scurvy. No marked difference was found in the intestinal flora under any of these conditions.

FURTHER STUDIES ON THE USE OF WATER-SOLUBLE B IN THE TREATMENT OF INFANT MALNUTRITION.

BY WALTER H. EDDY.

(From the Society of the New York Hospital, New York.)

Results of experiments were reported confirming previous work⁵ of the author in stimulating growth by the addition of B vitamine extract to the diet of infants suffering from malnutrition of the marasmus type. A new feature used in the study was the application of the Bachmann test⁶ to measurement of dosage.

In experiments with vitamine prepared from the navy bean by the McCollum method⁷ the test detected relatively small amounts of vitamine and, while in need of further standardization, offered a valuable aid in measurement of the vitamine B present in the substances used. Tables were shown giving the result of the test on various amounts of the dextrin-vitamine mixture and on other substances such as milk, both cow and human milk.

The first case, showing stimulation with the B vitamine, gained an average of 0.84 ounces per day in a 32 day period as against a gain of 0.47 ounces per day during a 17 day period preceding the use of the vitamine through the calorie intake and the food given remained constant through both periods. The second case showed a similar stimulation though not so well controlled as the first. The interesting feature of the use of the Bachmann test as applied to the first case was the result of the tests as applied to the child's diet and to the extract. The diet

⁵ Eddy, W. H., and Roper, J. C., *Am. J. Dis. Child.*, 1917, xiv, 189.

⁶ Bachmann, F. M., *J. Biol. Chem.*, 1919, xxxix, 235.

⁷ McCollum, E. V., and Simmonds, N., *J. Biol. Chem.*, 1918, xxxiii, 55.

was found to contain 2,120 units of vitamine and the stimulating mixture only 70 units.

In other words an increase of only 3 per cent in actual vitamine intake produced the marked stimulation. The author suggested that this result may be due to the fact that the child could utilize the extracted vitamine when it could not utilize the vitamine in the diet and that the way the vitamine is held in a diet may be an important factor. In all the baby cases treated the extract feeding is followed by an increased growth which continued to a point where removal of the extract is possible without marked reduction in the growth rate and the child then goes on to recovery. These cases represent the fifteenth and sixteenth showing stimulation under this treatment.

THE EXOGENOUS AND ENDOGENOUS NATURE OF THE CREATINURIA IN THE GROWING DOG.

BY VICTOR JOHN HARDING AND ELRID G. YOUNG.

(*From the Biochemical Laboratory, McGill University, Montreal.*)

In investigating the creatinuria of pups, and studying the effect of high and low protein diets upon that condition, the authors find in most of the animals that the creatine excretion is dependent upon the level of protein intake. Only in one animal, however, did they find that the creatinuria could be totally abolished by a low protein diet, and even in this case creatine again made its appearance in the urine in spite of the low protein diet. In most of the animals investigated there always remained a residuum of creatine in the urine, which invariably increased on a continuation of the low protein diet. This increase in the creatine excretion, following its lowering with a low protein diet, is ascribed to the production of that substance from some store of intermediary metabolites. The authors are thus of the opinion that creatine can be of both exogenous and endogenous origin and that both can exist in the same animal. The endogenous creatine is not a constant quantity, and its amount is determined by factors as yet unknown. In two animals, however, the authors were unable to affect the excretion of creatine by an alteration in the protein of the diet. In these animals apparently the endogenous fraction is so large as to obscure the exogenous portion.

CYSTINE AS THE PRECURSOR OF CREATINE IN THE GROWING DOG.

BY VICTOR JOHN HARDING AND ELRID G. YOUNG.

(From the Biochemical Laboratory, McGill University, Montreal.)

The authors have investigated the effects upon the exogenous creatine excretion in pups of variations in the amino-acid content of the protein.

Arginine is without any effect. A variation in the content of the cystine in the protein or the addition and withdrawal of that amino-acid as such is followed by a variation in the creatine excretion. It is found, however, that as well as affecting the exogenous function of the creatine the endogenous portion is also disturbed.

The hypothesis has been formulated that cystine forms creatine through the intermediate stages of taurine and amino ethyl alcohol, followed by methylation, combination with urea, and oxidation.

THE ORIGIN OF CREATINE.

BY R. B. GIBSON AND FRANCES T. MARTIN.

(From the Chemical Research Laboratory, Department of Theory and Practice of Medicine, the State University of Iowa, Iowa City.)

Ingested creatine is promptly eliminated chiefly as creatine, in part as creatinine, in cases of advanced progressive pseudohypertrophic muscular dystrophy. The creatine and to a lesser extent the creatinine are increased with a high protein intake inasmuch as in the case reported half again as much creatinine and twice as much creatine may be excreted as on a low nitrogen plane. This increase is obtained from the catabolized protein (including gelatin) and not from that retained for growth purposes. The substitution of the arginine-rich protein edestin for the protein of the diet does not affect the creatine output. Ingested asparagine and sarcosine do not lead to increased creatine formation; glycoeyamine is converted in part (at least 36 per cent) in a controlled experiment, thus confirming earlier work. It is probably not a stage in the ordinary creatine formation.

**CORRELATION OF CERTAIN PHYSICAL AND CHEMICAL FACTORS
WITH TOXICITY TO MARINE ORGANISMS.**

BY G. H. A. CLOWES AND L. G. KEITH.

*(From the Biochemical Research Laboratory, Eli Lilly and Company,
Indianapolis.)*

The absolute and relative toxicities of the symmetrical and asymmetrical dichloroacetones to developing sea urchin eggs correspond with their toxicities to mice, the symmetrical compound being sixty times as toxic as the asymmetrical.

Experiments with mustard gas and other war gases have indicated that their relative toxicities depend upon rate of hydrolysis, lipid water distribution coefficient, vapor tension, etc. The dichloroacetone experiments support this view. The symmetrical compound diffuses more rapidly from a non-aqueous to an aqueous phase, and hydrolyzes more rapidly in a feebly alkaline aqueous phase than does the asymmetrical.

With both substances a latent period was observed, during which the gases could be removed by shaking with additional eggs or charcoal, the protective effect depending upon temperature, time of application, and amount of protective substance employed.

An analysis of the data obtained by exposing varying numbers of eggs to varying concentrations for varying times at varying temperatures, and subjecting them to varying protective procedures, supports the view previously advanced that the war gases are first adsorbed on the surface of the protoplasmic structure, then penetrate through protoplasm by diffusion, and finally after a latent period undergo hydrolysis causing the death of the cell.

METABOLISM OF O-NITROBENZALDEHYDE, M-NITROBENZALDEHYDE, AND P-NITROPHENYLACETALDEHYDE.

BY CARL P. SHERWIN, JOHN A. DALY, AND WALTER A. HYNES.

(From the Research Laboratory, Fordham University, New York.)

According to the investigations of Cohn, *o*-nitrobenzaldehyde, when fed to the rabbit, is mostly destroyed, and only about 10 per cent is excreted in the urine as *o*-nitrobenzoic acid. *m*-Ni-

trobenzaldehyde is excreted by the rabbit as *m*-acetylaminobenzoic acid, and by the dog as *m*-nitrohippuric acid urea. *p*-Nitrobenzaldehyde is excreted by the rabbit as a combination of *p*-nitrobenzoic acid and *p*-acetylaminobenzoic acid, and by the dog *p*-nitrobenzaldehyde is excreted in the urine as *p*-nitrohippuric acid urea.

We fed 2 gm. of *o*-nitrobenzaldehyde to a man and recovered 65 to 70 per cent of *o*-nitrobenzoic acid from the urine. No reduction of the nitro group was apparent in this case, nor was there any combination with glycocoll by the *o*-nitrobenzoic acid thus produced.

m-Nitrobenzaldehyde was fed to a man in 5 and 6 gm. doses. From the urine we recovered about 75 per cent of the substance in the form of *m*-nitrobenzoic acid, and after the 6 gm. dose a fraction of a gm., about 5 per cent, was found as *m*-nitrohippuric acid.

p-Nitrophenylacetaldehyde was fed to a rabbit in 1 gm. doses, and 75 to 80 per cent was excreted as *p*-nitrophenylacetic acid, while *p*-nitrophenylacetic acid, when fed, resulted in rapid elimination of the same substance in the urine. 5 gm. of *p*-nitrophenylacetaldehyde were also fed to a dog and excreted in the urine as *p*-nitrophenylacetic acid. *p*-Nitrophenylacetic acid, as previously shown by one of us, is excreted mostly as the same substance in the urine of the dog, but a small fraction was also excreted in combination with glycocoll as *p*-nitrophenaceturic acid. 5 gm. of *p*-nitrophenylacetaldehyde were ingested by a man and 70 per cent of this was recovered from the urine as *p*-nitrophenylacetic acid. *p*-Nitrophenylacetic acid, as we have previously shown, is excreted by the human uncombined.

In these cases we could find no reduction of the nitro group in any of the aldehydes, as found by Cohn in his work on rabbits, so we fed 5 gm. of *p*-aminophenylacetic acid to a human, and again to a dog. In both cases there appeared in the urine a dark red substance, easily soluble in all organic solvents and insoluble in water. This substance has not as yet been crystallized or identified.

**RELATION BETWEEN AMMONIA EXCRETION AND THE
HYDROGEN ION CONCENTRATION OF URINE.**

BY CYRUS H. FISKE.

(From the Biochemical Laboratory, Harvard Medical School, Boston.)

Hasselbach's supposed constant relation between the ammonia coefficient and the C_H of urine is subject to deviations of sufficient frequency to suggest that other controlling factors are concerned. An examination has consequently been made, on hourly samples of human urine, of (1) the C_H , and (2) a ratio, that is more likely than the ammonia coefficient to have a real significance in connection with the regulation of reaction; *viz.*, the ratio of ammonia to sulfuric acid. Other things being equal, this ratio rises with the C_H , but the relation is by no means constant under all conditions. At the same C_H , the ratio is lower the higher the sulfate content, and also the higher the phosphate content. The dependence on the sulfate excretion may be explained by the fact that acids, other than sulfuric, that call for the formation of ammonia, are relatively less in amount the greater the rate of production of sulfuric acid, while the dependence on the phosphate output is perhaps to be accounted for by the supposition that the demand for ammonia is less the greater the amount of phosphate available for excretion, since the conversion of secondary to primary phosphate liberates fixed alkali.

**THE AMINO-ACID CONTENT OF BLOOD FROM THE JUGULAR
AND MAMMARY VEINS OF MILKING COWS.**

BY C. A. CARY.

(From the Research Laboratories of the Dairy Division, Bureau of Animal Industry, United States Department of Agriculture.)

An attempt was made to determine the change in the amino-acid content of blood and of blood plasma as it passes through the mammary gland of milking cows by comparing the amino-acid N in samples obtained as nearly simultaneously and with as little disturbance as practical from the jugular and mammary (abdominal subcutaneous) veins.

The proteins were removed by the coagulation-trichloroacetic acid-kaolin method described by Bock,⁸ the amino N being determined by the HNO₂ method, using the smaller apparatus of Van Slyke. The urea, etc. were corrected for by making duplicate runs allowing a longer time for deamination.⁹

The averages of duplicate analyses of plasma are given in Table I.

TABLE I.

Vein.	Amino-acid content of 100 cc. of blood plasma.					
	I	II	III	IV	V	VI
	<i>mg.</i>	<i>mg.</i>	<i>mg.</i>	<i>mg.</i>	<i>mg.</i>	<i>mg.</i>
Jugular	2.68	3.31	2.41	2.49	2.38	2.47
Mammary	1.78	2.34	2.45	1.93	2.00	1.87
Difference	0.90	0.97	0.04	0.56	0.38	0.60

The cows gave about 10 kilos of milk daily. The plasma constituted about 67 per cent by volume of the whole blood. Using a very rough approximation¹⁰ of the flow of blood through the mammary gland, assuming that the difference in amino-acid content of the mixed arterial and jugular bloods is relatively negligible, and that the changes in the plasma thus indicated are effected continuously throughout the 24 hours, our largest differences indicate that about 35 gm. of amino-acid N are abstracted daily from the plasma passing through the gland. This estimate is rough and it is very doubtful whether we get samples of blood indicating the maximum changes occurring in the gland. It is, however, suggestive relative to the formation of milk proteins.

With the whole blood the differences are in general in the same direction as those found in the corresponding plasma, but more work must be done to determine whether there is any change or not in the amino-acid N of the corpuscles of blood perfusing the gland. The work is still in progress.

⁸ Bock, J. C., *J. Biol. Chem.*, 1916-17, xxviii, 357.

⁹ Van Slyke, D. D., and Meyer, G. M., *J. Biol. Chem.*, 1912, xii, 399.

¹⁰ Meigs, E. B., Blatherwick, N. R., and Cary, C. A., *J. Biol. Chem.*, 1919, xxxvii, 21.

NEUTRALITY REGULATION IN CATTLE.

BY N. R. BLATHERWICK.

(From the Research Laboratories of the Dairy Division, Bureau of Animal Industry, United States Department of Agriculture.)

The alkaline reserve of the plasma of cows, as measured by the CO₂ capacity, is remarkably constant. The average normal value, 60.9 cc. of CO₂ per 100 cc. of plasma, is somewhat lower than that of normal human plasma. Maximum and minimum values were 65.5 and 55.1 cc., respectively. The CO₂ capacity of the plasma of three pregnant cows showed no evidence of the acidosis of pregnancy observed by others in women. By feeding a cow on rations restricted to one food, namely hay, grain, or silage, changes in plasma CO₂ capacity and in the ammonia and CO₂ of the urine were produced. A cow fasted for 7 days failed to show a decrease in the CO₂ capacity of the plasma, but rather a slight increase apparent at 24 hours, which was maintained throughout the fast. Coincident with this was an increase of 11 per cent in the inorganic P of the plasma. Larger increases in the inorganic P of the plasma, as the result of fasting, have been found in this laboratory. This change indicates a mobilization of bone substance to assist in the maintenance of neutrality. Another important factor in maintaining the correct reaction of the cow's body is the excretion of CO₂ in the urine. This has been observed to vary from 6 cc. per 100 cc. in the urine of a young calf living on a milk diet to 394 cc. in that of a cow eating silage, grain, and hay.

EFFECT OF ACIDS, ALKALIES, AND SALTS UPON CATALASE PRODUCTION.

BY W. E. BURGE.

(From the Department of Physiology, University of Illinois, Urbana.)

100 cc. of 0.15 per cent hydrochloric acid decrease the catalase of the blood about 30 per cent in 2 hours, while a similar quantity of acetic acid increases it about 14 per cent. The decrease produced by the hydrochloric acid is due in part to the destruction of the enzyme and in part to the inhibiting action of the acid; the increase produced by the acetic acid is due to the stimulation

of the alimentary glands, particularly the liver, to an increased output of the enzyme. Carbonic acid was found to have no effect on the catalase of the blood. 10 gm. per kilo of sodium carbonate as well as sodium acetate dissolved in 100 cc. of water increase the catalase of the blood. The animals used in these experiments were rabbits and the substances were introduced by means of a stomach tube.

A STUDY OF THE DISTRIBUTION OF CATALASE IN THE KIDNEY.

BY SERGIUS MORGULIS AND VICTOR E. LEVINE.

(From the Department of Biochemistry and Physiology, College of Medicine, Creighton University, Omaha.)

Experiments with the kidney of rabbit, sheep, pig, and beef, perfused with saline and unperfused, indicate a catalase content (quantity of hydrogen peroxide decomposed) and a catalytic activity (rate of decomposition) which are much greater in the cortex than in the medulla. The upper portion of the medulla yields greater values than the papillary portion. Part of the catalase is derived from the blood and can be removed by perfusion; part remains insoluble even after prolonged perfusion. Results with the right and the left kidney from the same animal point to the fact that the two organs differ in catalase content and catalytic activity. The kidney tissue contains no direct oxidizing enzyme. Quantitative experiments on peroxidase show that the peroxidase relations are the opposite of those of catalase. The greatest peroxidase content and peroxidase activity (rate of reaction) are found in the medulla; the cortex values are comparatively small. Perfusing the kidney results in the complete removal of peroxidase, although catalase is removed only in part by this procedure.

THE SIGNIFICANCE OF CONCENTRATION WITH REFERENCE TO
SUBSTANCES IN THE BLOOD PLASMA.

BY R. T. WOODYATT.

(From the Laboratory of Clinical Research, Rush Medical College, the Otho S. A. Sprague Memorial Institute, Chicago.)

A dog weighing 10 kilos received glucose by vein constantly for 8 hours at the uniform rate of 10 gm. per hour. In the first 4 hours the glucose was given in dilute solution; in the second 4 hours in concentrated solution; *i.e.*, first in about 3 and later in about 36 per cent form. The dog passed in the urine 0.1 to 0.2 gm. of sugar per hour throughout (except in the first hour). In the 2nd, 3rd, 4th, and 5th hours the blood sugar percentage was 0.13 to 0.14 per cent. In the 6th, 7th, and 8th hours it was 0.21 to 0.23 per cent. This change followed the change in the volume of water injected and occurred while the rates of glucose injection, glucose elimination, and hence glucose utilization all remained constant. If anything, the glucose excretion was a trifle higher during the period of low blood sugar percentages. The experiment is one of a group and depicts a type.

The phenomenon was discussed in relation to the observations of Magnus on salts; and Epstein on the blood sugar and rate of glycosuria in diabetes. It was pointed out that if the surface of contact between the blood and the cells should vary in direct proportion to the blood volume, the results would be explained. Anatomical details of capillary systems were discussed to show how an increasing volume of capillary blood—especially by opening up erstwhile empty capillary collaterals—may develop surface approximately in proportion to the volume of extra blood.

In interpreting the physiological effects of a substance in the blood plasma, the factor of concentration alone is not sufficient. Surface is also important. Possibly during normal variations of the blood volume, surface and volume vary in direct proportion.

ALKALOID DIFFUSION IN PHYSICAL AND BIOLOGICAL SYSTEMS.

By G. H. A. CLOWES AND A. L. WALTERS.

(From the Biochemical Research Laboratory, Eli Lilly and Company,
Indianapolis.)

Alkaloids adsorbed by fullers' earth cannot be released by extraction with water or an aqueous solution of sodium bicarbonate having the alkalinity of intestinal contents. Nevertheless when the alkaloid adsorption compound is administered by mouth, the alkaloid is adsorbed by the intestinal mucosa. It was found, for example, that adsorbed atropine administered to cats by mouth produced a prolonged dilatation of the pupil of the eye. Adsorbed strychnine caused convulsions and death in rabbits and rats, and adsorbed quinine and emetine were recoverable in the urine. Adsorbed strychnine introduced into the peritoneal cavity caused convulsions and death, but when the adsorbed strychnine was first introduced into a collodion sac which was freely permeable for strychnine but would not permit of the passage of cells, and the sac introduced into the peritoneal cavity, there was no effect.

These experiments show that the alkaloid may be extracted by protoplasm in a neutral medium and suggest the probability that the alkaloid is released by direct contact between the protoplasmic material of the cell and the adsorption compound.

In the above experiments from two to ten times the amount of adsorbed alkaloid was required to produce a result equivalent to that obtained in control experiments with free alkaloid. Alkaloids were extracted from their adsorption compounds to a slight extent by intestinal contents, somewhat better by means of intestinal mucosa, egg yolk, etc., but with considerable facility by so called neutral soaps and soaps to which either fatty acid or alkali had been added. The extracts were carried out either in aqueous or mixed aqueous organic media or in emulsions using soaps of sodium, potassium, calcium, and magnesium.

These results support the view that soaps and the fatty acid group play an important rôle in protoplasmic assimilation, and explain the therapeutic effects obtained by administering alkaloids in the adsorbed form.

THE NATURE OF THE LIGHT-PRODUCING REACTION OF
LUMINOUS ANIMALS.

By E. NEWTON HARVEY.

(From the *Physiological Laboratory, Princeton University, Princeton.*)

Animal luminescence results from the oxidation of a substance, luciferin (LH_2), in presence of a catalyst, luciferase, water, and oxygen. When solutions of luciferin and luciferase are mixed, not enough CO_2 is produced to saturate the buffers in these solutions and probably no CO_2 at all is produced; not enough heat is produced to raise the temperature of the mixture $0.001^\circ C.$, and from this figure the heat of oxidation of luciferin is calculated to be less than 0.1 calorie per gm. The oxidation product of luciferin, oxyluciferin (L), is very similar to luciferin and may be reduced to luciferin again by various perhydridases and by nascent hydrogen or H_2S . The reduction is accelerated by acid and in the presence of light. Thus the reaction is photogenic in one direction, photochemical in the opposite direction, and may be represented as follows:

Darkness.

Alkali.

Luciferase.

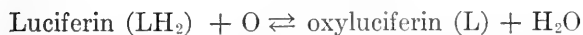

Perhydridase or nascent H.

Acid.

Light.

THE INFLUENCE OF OXYGEN DEFICIENCY AND RELATED
CONDITIONS UPON THE HEMATO-RESPIRATORY
FUNCTIONS.

By YANDELL HENDERSON AND HOWARD W. HAGGARD.

(From the *Physiological Laboratory, School of Medicine, Yale University, New Haven.*)

It is generally supposed that under oxygen deficiency acids are produced in the tissues and are retained in the blood, and that the blood alkali is thus neutralized and eliminated through the urine. This may be termed the acidotic process.

Experiments on dogs subjected to progressively decreasing oxygen show, however, that the process actually involved is in many respects exactly the opposite of the usual supposition. They demonstrate that before any considerable amount of alkali is lost an abnormally large amount of CO_2 is eliminated by the excessive breathing induced by a lowered oxygen pressure in the air breathed. Then alkali passes out of the blood to compensate this alkalosis. This we term the acapnial process.

From these facts and related observations on men it appears that in normal persons the blood alkali is controlled by the dissolved CO_2 more or less alkali being called into use in the blood to satisfy the normal $\text{H}_2\text{CO}_3 : \text{NaHCO}_3$ relation, and thus to keep the C_{11} of the blood nearly constant. The amount of dissolved CO_2 in the blood is controlled by the pulmonary ventilation, and fundamentally in normal persons the ventilation is adjusted to the oxygen partial pressure of the altitude at which the person lives.

When, however, overbreathing is induced and the H_2CO_3 of the blood is reduced, the NaHCO_3 follows downward. This, we find, and not acidosis, is what occurs also in carbon monoxide asphyxia.

A simple test for differentiating between low blood alkali of acidotic and that of acapnial origin is the administration of air to which 8 to 10 per cent of CO_2 has been added. This quickly causes death in acidotic subjects; but it induces a rapid recall of alkali to the blood, and restoration of the subject to a virtually normal condition of health if the condition is of acapnial origin.

We have now (in collaboration with Dr. R. C. Coburn) applied this treatment to patients after surgical operation and anesthesia. The result has been that alkali was recalled to the blood, that arterial pressure and other functions were restored to normal, and that the anesthetic was rapidly eliminated by the full breathing during the CO_2 inhalation with a consequent great reduction of nausea.

In dogs asphyxiated with carbon monoxide (in investigations for the United States Bureau of Mines) strikingly beneficial results have been obtained by means of oxygen reenforced with 10 per cent CO_2 .

RELATION OF ANESTHESIA TO RESPIRATION.

BY SHIRO TASHIRO.

(From the Biochemical Laboratory, College of Medicine, University of Cincinnati, Cincinnati.)

The rate of the tissue respiration of the claw nerves of various crabs is highest in lobster, then spider crab, and least in *Limulus*. That of the sciatic nerve of frog comes between the last two. The time required for complete anesthesia with the same narcotics is shortest for lobster, then spider crab, frog, and *Limulus* in order. Susceptibility of the nerve to anesthetics runs parallel to the rate of its respiration, provided that other factors are fairly constant. A 0.4 per cent solution of chloral hydrate does not alter the original gradient of respiration of the spider crab's nerve, but 2 per cent, which produces reversible loss of irritability, reverses it. These results can be best explained if we accept the idea that susceptibility of the same nerve toward anesthetics is quite different along the fiber, depending mainly upon the different respiratory activities of the different parts of the fiber. The advantage of using tissue with as few functions as possible is obvious, for we must know exact physiological conditions of all parts of the tissue when we measure the respiration. Abolition of one function in a tissue may or may not mean complete anesthesia of the tissue as a whole. It is suggested that primary stimulation by weak concentrations of narcotics is probably caused by exaggerating the original metabolic gradient; and final anesthesia, by further oxidative interference which primarily changes the relation between tissue respirations of the different parts of the tissue.

DETERMINATION OF METHEMOGLOBIN IN BLOOD.

BY W. S. McELLROY.

(From the Laboratory of Physiological Chemistry, School of Medicine, University of Pittsburgh, Pittsburgh.)

When methemoglobin is present the colorimetric determination of hemoglobin cannot be used as an index of the oxygen-carrying capacity of the blood. Under these conditions the oxygen capacity must be determined directly.

Methemoglobin interferes with the colorimetric determination of hemoglobin as carbon monoxide hemoglobin and acid hematin.

The total hemoglobin in the presence of methemoglobin can be determined colorimetrically by converting the oxyhemoglobin into methemoglobin by means of potassium ferri cyanide or other suitable reagent and determining the total as methemoglobin.

The oxygen capacity gives the amount of oxyhemoglobin.

The difference between the total hemoglobin determined as methemoglobin and the oxyhemoglobin estimated from the oxygen capacity gives the amount of methemoglobin.

BLOOD PHOSPHATES IN THE LIPEMIA PRODUCED BY SEVERE HEMORRHAGE.

By W. R. BLOOR AND E. D. FARRINGTON.

(From the Department of Biochemistry and Pharmacology, University of California, Berkeley.)

Changes directly connected with the lipemia were confined to increases in lipid phosphorus in plasma (up to five times the normal value) and in corpuscles (double the normal value).

Changes attributable to the bleeding and regeneration were mainly increases in the inorganic phosphates in the corpuscles and, to a less extent, changes in the quantities of the other phosphoric acid combinations.

FAT CONTENT OF EMBRYONIC LIVERS.

By C. G. IMRIE AND S. G. GRAHAM.

(From the Laboratory of Pathological Chemistry, University of Toronto, Toronto.)

Observations were made upon the fat content of the livers of embryonic guinea pigs throughout the period of gestation. Such changes, if any, had first to be established before the relation of the embryonic liver to fat mobilized from the storehouses in the pregnant animal could be interpreted. The results of this preliminary investigation were reported. The higher fatty acid content was determined by saponification and extraction, as described by Leathes, and the iodine value by the method of Wij. The weight of the embryo was employed as an indication

of its age. Until the embryo reaches a stage in its development corresponding to a weight of 35 to 40 gm., the fat content of the liver more or less closely approximates that of the maternal liver, which is from 2 to 3 per cent. After this period, however, there is a progressive accumulation of fat in the embryonic liver, so that at birth the animal has from 16 to 18 per cent of higher fatty acids reckoned upon the moist tissue. The iodine value of this fat was comparatively high, though lower than that in the maternal liver.

A study of the fate of this fat showed that it is rapidly utilized by the animal during the first 48 to 72 hours of its life. As the fat content is lowered during this period, the iodine value rises.

Figures and charts representing these changes were presented.

QUANTITATIVE COLORIMETRIC DETERMINATION OF TYROSINE AND TYRAMINE (P-HYDROXYPHENYLETHYLAMINE) AND OTHER PHENOLS.

BY MILTON T. HANKE AND KARL K. KOESSLER.

(From the Otho S. A. Sprague Memorial Institute and the Departments of Pathology and Physiological Chemistry, University of Chicago, Chicago.)

A method has been developed for estimating tyrosine, tyramine *p*-cresol, oxyphenylacetic acid, and phenol by means of which quantities as small as 0.000005 gm. of these substances can be determined. The method is based upon the interaction, in alkaline solution, of the phenols with *p*-phenyldiazonium sulfonate. The color so obtained is intensified and stabilized by the addition of NaOH and hydroxylamine hydrochloride. The theory of the reaction involving the stabilization of the quinone ring by the hydroxylamine was discussed in detail.

QUANTITATIVE COLORIMETRIC DETERMINATION OF HISTIDINE
AND HISTAMINE IN PROTEINS AND PROTEIN-CONTAINING
MATTER.

BY KARL K. KOESSLER AND MILTON T. HANKE.

(From the *Otto S. A. Sprague Memorial Institute and the Departments of Pathology and Physiological Chemistry, University of Chicago, Chicago.*)

A method has been developed for estimating histidine and histamine in proteins and protein-containing matter that is based upon the method developed for pure imidazoles and previously described by us,¹¹ and upon the method developed by Van Slyke for the estimation of the hexone bases.¹²

DIGESTIBILITY OF RAW CORN-STARCH.

BY C. F. LANGWORTHY AND HARRY J. DEUEL, JR.

(From the *Office of Home Economics, States Relation Service, United States Department of Agriculture.*)

Raw starches are generally considered to be digested only slightly, if at all, by the human body. In the experiments here reported the digestibility of raw corn-starch when eaten in quantity by normal men was determined. There were some variations, but on an average the three subjects ate 250 gm. of raw corn-starch a day during the 3 day experimental period, in the form of a frozen custard, in which the starch was combined with milk, sugar, and a little salt, and flavored with lemon extract to mask the "starchy" taste. The methods were those usually followed in experiments with cereals carried on in this laboratory. The total amount of feces pertaining to the experimental period was very small and on examination did not show any starch.

The digestibility of the raw corn-starch was found to be 100 per cent. So far as could be seen, its ingestion had no abnormal physiological effects and the subjects remained in their accustomed good health.

The experiments here reported are the first of a series dealing with the digestibility of raw starches, in which it is planned to include potato, rice, wheat, arrowroot, and possibly other starches.

¹¹ Koessler, K. K., and Hanke, M. T., *J. Biol. Chem.*, 1919, xxxix, 521.

¹² Van Slyke, D. D., *J. Biol. Chem.*, 1911-12, x, 15.

SPERM AS AN INHIBITANT OF MATURATION AND FERTILIZATION.

BY G. H. A. CLOWES AND ESTHER GREISHEIMER.

(From the Biochemical Research Laboratory, Eli Lilly and Company, Indianapolis.)

Immature starfish eggs are prevented from maturing by treatment with butyric acid, exposure to heat, etc., the identical procedures which, after maturation, induce artificial parthenogenesis.

Similarly exposure of the immature eggs to sperm, even in small amounts, inhibits or retards maturation rendering the eggs unfertilizable or difficultly fertilizable by sperm, at a subsequent stage at which control eggs not previously treated with sperm are readily fertilized.

The best contrasts may be obtained by giving the immature eggs a preliminary exposure to a weak butyric acid solution which retards but does not prevent maturation. This treatment followed immediately by exposure to sperm causes a marked interference with maturation and subsequent fertilization as compared with eggs which receive the butyric treatment only. Heat followed by sperm gives similar results.

Inhibiting effects of sperm on immature eggs may be counteracted by a brief treatment with 0.001 N NaOH, but not ammonia. The similarity of inhibiting effect obtained by butyric acid and sperm separately or in combination, and the reversal of these effects by NaOH, suggest that inhibiting effect of sperm is attributable to production of acid on or adjacent to egg surface.

COLLOID CHEMISTRY OF SOAPS AND PROTEINS.

BY MARTIN H. FISCHER.

(From the Physiological Laboratory, University of Cincinnati, Cincinnati.)

On the assumption that the polymerized amino-acids which we call proteins react with bases of various sorts to form salts in the same fashion in which fatty acids unite with bases of various sorts to form soaps, the colloid chemistry of the latter was studied to obtain light regarding the colloid behavior of the former.

The hydration capacity of the soaps varies with the basic radical and, in general, in the order: NH_4 , K, Na, Li, Mg, Ca, Fe, Cu, Hg. It varies also with the type of fatty acid, that standing lowest in any homologous series being least hydratable. When different series are compared, the less saturated possess the lower hydration capacity.

Colloid soap jellies may be prepared from the various soaps and anhydrous solvents, like monatomic, diatomic, and triatomic alcohols, aldehydes, benzene, toluene, etc. This finding speaks against the too heavy emphasis now being placed upon purely electrical notions of stabilization in colloid systems.

Hydrophilic or lyophilic colloids are defined as dispersions, coarser than molecular, of one material in a second with the dispersed substance a solvent for the dispersion medium.

Liquid soaps may be "coagulated" by alkalies and neutral salts of various kinds even when chemical reaction between soap and added substances is impossible. The consecutive changes of setting, secondary liquefaction with progressive dehydration of the soap, and its separation in "coagulated" form are explained on the basis of union between added salt and water with production of an emulsion of salt water in soap succeeded by one of soap in salt water and ending in anhydrous soap floating upon salt water.

Chemically neutral soaps do not affect an indicator like phenolphthalein in concentrated solution. On diluting with water they turn it bright red. This means either (1) that water-in-colloid systems (analogous to normal cells and body fluids) cannot be properly analyzed by indicator methods but only colloid-in-water systems (analogous to the secretions from the body) or (2) that the former contain no ions.

From qualitative and quantitative analogy in colloid behavior between soaps and protoplasm the latter is held, in essence, to be a salt compound of various polymerized amino-acids with potassium, sodium, magnesium, calcium, etc., which materials have "dissolved" a certain amount of water. Introduction of acid, ammonia, or potassium into this compound represents poisoning by these materials at one end of such a soap-like series (as evidenced by increased hydration capacity and increased solubility in water); introduction of the heavy metals poisoning at

the other end (as evidenced by a decreased hydration capacity and the production of difficultly soluble compounds). Just as a soap anywhere in the series can, by appropriate means, be converted into any other, just so can a normal protein or living cell be "poisoned" through the addition of materials found at either extreme in the base series; or after such poisoning be changed to nearer the normal by addition of the bases in the middle series.

PATHOGENESIS DUE TO VITAMINE DEFICIENCY IN THE RAT.

BY A. D. EMMETT AND FLOYD P. ALLEN.

(From the Research Laboratory of Parke, Davis and Company, Detroit.)

The rats were fed on definite dietary planes which would produce normal growth except for the lack of either vitamine A or B. From these groups, animals were selected which were representative. Care was taken to see that the animals were free from infection. Control tests were made on tissues from rats fed a complete diet.

The various tissues examined histologically were: thymus, thyroid, pancreas, testes, ovaries, adrenals, liver, spleen, ileum, colon, kidneys, heart, lungs, brain, optics, lower cord, and sciatic nerves. In the absence of vitamine B, the most noticeable changes were found in the almost complete atrophy of the thymus; hypertrophy of the adrenals; passive congestion; fatty infiltration; and at times fatty degeneration in the liver and some atrophy of muscle fibers of the heart. There was more or less passive congestion in the pancreas, spleen, ileum, colon, kidneys, and lungs. In the rats which lacked vitamine A in their diet, there were no special outstanding pathological findings. In marked contrast with the lack of vitamine B the livers showed no fatty changes, the adrenals no hypertrophy, and the thymus no atrophy. The control animals proved to be normal as far as histological examination showed.

RELATION OF VITAMINES AND IODINE TO THE SIZE AND DEVELOPMENT OF THE TADPOLE.

By A. D. EMMETT, FLOYD P. ALLEN, AND MARGUERITE STURTEVANT.

(From the Research Laboratory of Parke, Davis and Company, Detroit.)

In the light of our previous work, the temperature conditions, the exact food control, and the question of individual variation were especially borne in mind by keeping the tadpoles in an environment where the temperatures could be maintained within reasonable limits, and by keeping each tadpole in a separate vessel so that there could be no possibility of their eating each other.

The results confirmed the previous findings in regard to the size of the tadpoles; namely, that the presence of vitamins bore a direct relation to size, the water-soluble type B being more of a factor than the fat-soluble A. With respect to the development of the hind legs, the tadpoles having the vitamins in their diet did better than those without them. Vitamine B was apparently more essential than vitamine A. However, for the completion of the metamorphosis, iodine in the inorganic form or in the organic form as in the desiccated thyroid gland was essential. The relative values referred to were determined from time to time by measuring the total body length from shadow photographs, and by binocular observation every 10 to 14 days of the stage of development of the hind legs. Calculating the arithmetic mean for each group on the date observed served as the guide to the rate of advancement.

PENTOSE CONTENT OF SOME TISSUES OF MARINE ANIMALS.

By C. BERKELEY.

(From the Marine Biological Station, Nanaimo, B. C.)

The prevalence of complex pentosans and methylpentosans in marine algae make it a matter of interest to examine the tissues of animals whose diet they make up for compounds of the same class.

Many observations have been made on the occurrence of pentoses in animal tissues¹³ but the only systematic survey of the pentose content of various organs in one animal (the ox) is that by Grund.¹⁴ Although guanylic acid and inosinic acid are the only compounds in which it has been shown with certainty that the pentose exists certain workers have stated that complex pentosans or methylpentosans are present in certain mollusks living on algæ.

An examination of various tissues from a variety of marine animals indicated the presence of a substance soluble in boiling water, which while it yielded furfural was not precipitated by acetic acid from aqueous solution.

Before undertaking a further investigation of the nature of its combination it was thought important to ascertain the relative amounts of pentose in various marine animals.

For this purpose the tissues were first of all thoroughly extracted with alcohol and the air-dried residue was treated by Grund's modification of the method of Tollens and Kröbe for the determination of pentoses, the result being calculated as xylose, although it is probable that most if not all of the pentose is really present as *d*-ribose.

The following amounts of pentose were obtained: *Squalus* (dogfish) pancreas 2.28, spleen 0.67, kidney 0.65, liver 0.72, testis 0.92, heart 0.38, muscle 0.35 per cent; *Thais lamellosa* (gastropod) liver and gonads 1.15 per cent; *Evasterias troschelii* (starfish) liver 0.77 per cent.

Comparison of the results for the dogfish and for the ox as obtained by Grund show approximate correspondence, the most important difference being that there is relatively more pentose in the organs of the former except in the case of the pancreas, where the amounts are about the same in the two animals.

That the relatively high percentage in the liver (and gonads) of *Thais* may indicate that some is present in a polymerized form, is suggested by Röhmman and others for allied species.

¹³ For a summary of literature see Jones, W., *Nucleic acids: Their chemical properties and physiological conduct*, New York, 1914, 8, 33, 34.

¹⁴ Grund, G., *Z. physiol. Chem.*, 1902, xxxv, 111.

PENTOSAN- AND METHYLPENTOSAN-SPLITTING ENZYMES OF
MACROCYSTIS PYRIFERA.

BY C. BERKELEY.

(From the Marine Biological Station, Nanaimo, B. C.)

By the spontaneous fermentation of the giant kelp (*Macrocystis pyrifera*) in the presence of ground limestone, the kelp almost disappears in 2 to 3 weeks and the solution contains considerable quantities of the calcium salts of mono-basic fatty acids.

No free sugar occurs in the plant. The only carbohydrate constituents present in sufficient quantity to account for the acids produced are pentosan and methylpentosan complexes, the former soluble in dilute alkali and precipitated on acidification, the latter soluble in water and precipitated by alcohol.¹⁵ Breakdown of these complexes to simple sugars must precede acid formation, but no such sugar can be detected when the fermentation takes its normal course.

If freshly cut kelp is extracted with boiling water the extract is neutral, has no reducing properties, and contains methylpentosan, but no pentosan. If the kelp has been cut into small pieces a few hours the extract is acid, reduces Fehling's solution, and contains pentosan as well as methylpentosan.

If kelp is kept for a day or so in strong alcohol and subsequently steeped in warm water containing toluene or other antiseptic, free sugar develops rapidly and both pentose and methylpentose are found in solution. After more prolonged contact with alcohol no breakdown of the polysaccharides occurs on subsequently putting the kelp into water.

By extracting fresh kelp rapidly with frequent changes of alcohol, drying at a low temperature, and grinding, a preparation can be obtained which produces free sugar very rapidly on being added to a solution of either the pentosan or methylpentosan complex. No formation of acid occurs if an antiseptic is present.

From these observations the following conclusions are drawn:

1. Kelp contains enzymes which start to break down its polysaccharide constituents as soon as it is cut.

¹⁵ Hoagland, D. R., and Lieb, L. L., *J. Biol. Chem.*, 1915, xxiii, 287.

2. The enzymes are inactivated by prolonged contact with alcohol.

3. The production of acids sets in, in the normal course of fermentation, as soon as the sugars are set free and is probably due to the action of bacteria adherent to the kelp.

DIRECT DETERMINATION OF SODIUM IN TISSUES AS SODIUM-CESIUM-BISMUTH-NITRITE.

By R. D. BELL AND E. A. DOISY.

(From the Laboratories of Biological Chemistry, Washington University
Medical School, St. Louis.)

The insolubility of sodium-cesium-bismuth-nitrite, previously described by Ball,¹⁶ was utilized in the development of a method for the determination of sodium in tissues.

The organic matter is oxidized by a wet ash process with a mixture of nitric and sulfuric acids. Iron must be removed from the mixture of blood salts. The solution is made faintly alkaline to methyl orange and evaporated to 2 or 3 cc. 0.5 cc. of 2 N HNO₃ and an excess of reagent are added. After standing 2 days under illuminating gas, the precipitate is filtered off on a previously weighed Gooch crucible. The reagent is removed by washing with acetone. The crucible is dried at 100° and weighed.

Since the insoluble salt is a nitrite, it may be estimated by titration with potassium permanganate. 1 molecule requires 30 atoms of oxygen for oxidation.

The precipitate contains 3.675 per cent of sodium. 1 mg. of sodium yields 27.2 mg. of the insoluble nitrite.

The reagent is made from cesium nitrate, bismuth nitrate, and potassium nitrite. Any insoluble matter which forms is dissolved by the addition of a little dilute nitric acid.

Good results were obtained in the determination of known amounts of sodium. There was good agreement between results by this method and the indirect perchlorate procedure on blood and urine samples.

¹⁶ Ball, W. C., *J. Chem. Soc.*, 1910, xevii, 1408.

UROCHROME EXCRETION AS INFLUENCED BY DIET.

BY K. F. PELKAN.

(From the Department of Biochemistry and Pharmacology, University of California, Berkeley.)

Urochrome has long been known as a constituent of urine but its significance has never been definitely determined. Various workers have claimed its relation to the blood and bile colors and to the cellular metabolism of the organism and have denied that it was at all influenced by diet. The amount of experimental evidence submitted in favor of these claims has been small. The present work was undertaken to determine whether and to what extent the amount of urochrome excreted was dependent on the diet. Experiments carried out on a human subject resulted as follows: A low protein diet reduced the urochrome excretion up to 50 per cent, while a high protein diet raised it perceptibly. Gelatin added to a low protein diet did not affect the excretion. Colored substances were found in peptone and in amino-acid digestion mixtures which were similar in all respects to urochrome. All evidence points to the fact that urochrome is to a large extent derived from the proteins of the diet.

RELATION OF EXTRACT OF LUNG TO THE CLOTTING OF BLOOD.

BY C. A. MILLS.

(From the Department of Biochemistry, University of Cincinnati, Cincinnati.)

Whereas lung extract, if injected rapidly and in sufficient amounts into animals, causes extensive intravascular coagulation and death usually in less than 1 minute, if injected in small amounts at first and then repeatedly with increasingly larger doses, causes the development of a negative coagulative phase in the blood of the animal. Such blood, withdrawn from the vessels, will not clot spontaneously for days at 5°C., putrefaction usually setting in before clotting occurs. Neither will it clot on treatment with more of the lung extract, calcium salts, thrombin, serum, CO₂ gas, or dilution with water. It differs from peptone plasma in its non-coagulability in that it contains no antithrombin or other material to inhibit the clotting of

normal blood or oxalate plasma when added to it, but instead it actually possesses a strong thromboplastic action, probably due to the presence of unchanged lung extract in it.

As much as 1,150 cc. of lung extract have been injected into an 11 kilo dog without causing intravascular clotting, whereas 3 or 4 cc. would kill a dog of this size if injected rapidly in a single dose.

The non-coagulability is not due to the disappearance of fibrinogen from the blood, for the addition of an equal volume of saturated NaCl solution to this plasma always produced a precipitate of fibrinogen. Probably the fibrinogen has been altered by the injections, since it no longer clots with thrombin.

THE RÔLE OF PHOSPHORIC ACID IN CARBOHYDRATE METABOLISM.

By CYRUS H. FISKE.

(From the Biochemical Laboratory, Harvard Medical School, Boston.)

The hourly inorganic phosphate output in man falls and later rises during the morning in the absence of food. After the administration of sucrose while the rate of phosphate excretion is decreasing, the fall is much more marked. The ingestion of sucrose while the rate of phosphate excretion is increasing is likewise followed by a drop in the phosphate output. In either case there is later a compensatory rise, indicating that carbohydrate combustion is accompanied by the retention of phosphate, which is later excreted at an exaggerated rate. It is suggested that this may be an indication that sugar is decomposed in the body *via* a phosphoric acid ester, as in alcoholic fermentation by yeast. The observation may account for the phosphate retention after parathyroidectomy, since the tetany caused by this operation is accompanied by rapid loss of stored carbohydrate.

UREA IN DOGFISH AND SKATE.

BY C. C. BENSON.

(From the Biological Board of Control, and the Department of Food Chemistry, University of Toronto, Toronto.)

Determinations of urea in the muscle of dogfish and skate were made on fresh material, on material kept for varying times in cold storage and in the household refrigerator, and on material taken from cold storage and boiled.

In most cases, alcoholic solutions were used for analyses, using methods similar to those of Greene¹⁷ and in others the ammonia was aerated directly.¹⁸

Fresh dogfish gave 0.5 to 0.6 per cent of nitrogen from urea, specimens from cold storage, 0.4 to 0.57 per cent of urea nitrogen, and boiled specimens showed practically no loss of urea.

Specimens of the muscle of skate, fresh or directly after taking from cold storage, gave 0.6 to 0.8 per cent of urea nitrogen but this value decreased rapidly on keeping in the refrigerator.

The quantities of urea in both forms are too small to be injurious as food, both forms keep well in cold storage, but the skate rapidly forms ammonia from its urea on being thawed.

COMPOSITION OF THE TUBERS, SKINS, AND SPROUTS OF THREE VARIETIES OF POTATOES.

BY F. C. COOK.

(From the Bureau of Chemistry, United States Department of Agriculture, Washington.)

Data collected for 20 years by the Vermont, Maine, and New York State Experiment Stations show that an increased yield of potatoes results from spraying potato vines with Bordeaux mixture. This is true whether any *Phytophthora infestans* (late blight of the potato) is prevalent or not.

Because of the high price of copper sulfate in 1915, experiments extending over four seasons were inaugurated by the Department of Agriculture comparing the fungicidal properties of

¹⁷ Greene, C. W., *J. Biol. Chem.*, 1919, xxxix, 435.

¹⁸ Sumner, J. B., *J. Biol. Chem.*, 1916, xxvii, 95.

Pickering sprays (made with saturated lime water and less copper sulfate than Bordeaux) with standard Bordeaux spray.

Results with Pickering and Bordeaux sprays on two varieties of tubers at Arlington, Virginia, the past season showed an apparent increased yield of tubers and an increased percentage of solids compared with the control. Bordeaux-sprayed potatoes from several states the past season also showed increased yields and increased percentage of solids of the tubers. Green Mountain, Rural New Yorker, and Irish Cobbler tubers stored in the laboratory (average temperature 70°C.) from the time of digging in September, 1918, until sprouting had proceeded to the limit in the Spring of 1919, showed that the sprouts comprised respectively 7.2, 3.5, and 13.3 per cent of the total weight of the tubers, skins, and sprouts. A difference in the concentration or activity of the growth-promoting agencies is suggested. The analytical data for the sprouts, skins, and tubers of these and other samples show little variation in composition for the different varieties of potatoes.

Analyses of sprayed and unsprayed Green Mountain tubers, skins, and sprouts indicate that the spray did not alter the rate of growth or the composition of the sprouts.

The percentage distribution of the nitrogenous substances showed that the sprouts contained more protein, less water-soluble, about the same monoamino and amide nitrogen, and less diamino and other basic nitrogen than the tubers. The sprouts showed a selective action in withdrawing nitrogen, total ash, phosphorus, and water from the tubers in larger proportion than these constituents existed in the tubers.

GLYCOSURIA IN THREE CASES OF CHRONIC NEPHRITIS WITH EDEMA BUT WITH ONLY SLIGHT NITROGEN RETENTION.

BY VICTOR C. MYERS AND LUDWIG KAST.

(From the Laboratory of Pathological Chemistry and the Department of Medicine, New York Post-Graduate Medical School and Hospital, New York.)

So called "renal diabetes" has been the subject of considerable discussion since Lépine in 1895 postulated the existence of this rather interesting condition, in which the glycosuria is actually

the result of renal disease, and not due to hyperglycemia as in diabetes mellitus. About thirty cases have now been recorded in the literature. A few of these cases have shown definite evidence of renal disease aside from the glycosuria, although some would appear to be entirely free from the symptoms ordinarily associated with disease of the kidney. Renal diabetes has been compared with phlorhizin glycosuria, in which condition we have glycosuria without hyperglycemia. Some of the cases, and especially those which we wish to report, find a more direct analogy in the glycosuria of uranium nephritis. Here there is only a mild glycosuria, with a normal or nearly normal glycemia, and a constant proteinuria. Ryffel¹⁹ and Roger²⁰ have each reported a case similar in some respects to our own. Our three cases (two males, aged 54 and 62, and one female, aged 10) all showed marked proteinuria and edema, but little nitrogen retention, urea nitrogen figures of 11 to 29 mg. per 100 cc. of blood. One of the cases gave a normal blood sugar, but the other two showed a mild hyperglycemia such as is ordinarily encountered in severe nephritis. In one of these the glycosuria was shown by Bailey²¹ to be entirely independent of the slight hyperglycemia. The figures for the urine sugar content ranged from negative findings to slightly over 2 per cent, although when sugar was present, it most often amounted to about 0.5 per cent.

**A SIMPLIFIED METHOD FOR THE ESTIMATION OF MORPHINE
TOGETHER WITH DATA ON THE DISTRIBUTION OF THE
ALKALOID IN ACUTE POISONING.**

By SERGIUS MORGULIS AND VICTOR E. LEVINE.

(From the Biochemical Laboratory, College of Medicine, Creighton
University, Omaha.)

Morphine can conveniently be determined in food, tissue, or body fluid by heating with 2 per cent tartaric acid (if solid, the material should first be ground or finely minced) to convert all morphine into the soluble tartarate. The mixture is rapidly cooled, preferably on ice, to solidify the fatty material. The

¹⁹ Ryffel, J. H., *Quart. J. Med.*, 1915-16, ix, 91.

²⁰ Roger, H., *Presse méd.*, 1917, xxv, 337.

²¹ Bailey, C. V., *Am. J. Med. Sc.*, 1919, clvii, 221.

solid residue is removed by straining through cheese-cloth, and washed until the washings are no longer acid to litmus. The liquid, after being filtered through paper, is evaporated to a pasty consistency. The tartarate is then decomposed by the addition of an excess of solid sodium bicarbonate, which sets the alkaloid free. The evaporation is then continued to complete dryness, and the mass powdered and extracted with chloroform to remove the free morphine. The volume of the chloroform extract is noted, and the smallest quantity of the extract is found which on evaporation (in a porcelain crucible over water bath) leaves a residue which yields a definite morphine test. In this way, the relative amount of morphine in several extracts can be determined; knowing the limit of sensitivity of the reaction an approximate estimate of the amount of morphine in the original sample is possible.

The various alkaloidal tests can be applied to the residues after the evaporation of portions of the chloroform extract. The reagent employed—selenium dioxide dissolved in concentrated sulfuric acid—is very sensitive towards the opium alkaloids. It is more sensitive than many of the older reagents.

From experiments on rabbits with acute poisoning the conclusion drawn is that morphine, whether given subcutaneously or by mouth, is widely distributed throughout the animal body, finding its way into almost every tissue. The morphine is invariably found in appreciable quantities in the urine and kidney. Also large quantities may be present in the alimentary tract, liver, lungs, and brain. According to our results especially large amounts of morphine were present in the alimentary tract and excretory organs after administering the poison by mouth, while after injecting under the skin it was recovered principally from the liver, excretory organs, and also from lungs and brain. In view of these findings, it is not feasible to limit the toxicological examination for morphine to the alimentary tract *alone*. An examination of at least the kidney, urine, and liver is also indispensable.

**ON THE PROTECTION AGAINST EOSIN HEMOLYSIS AFFORDED
BY CERTAIN SUBSTANCES.**

BY C. L. A. SCHMIDT AND G. F. NORMAN.

(From the Department of Biochemistry and Pharmacology, University of California, Berkeley.)

It was found that the inability of gelatin to afford any protection against the photodynamic action of eosin on red cells while marked protection is shown by blood serum, casein, edestin, and certain other proteins can be directly attributed to the lack of tyrosine and tryptophane, since the amino-acids can themselves afford marked protection. The presence of the benzene ring in a molecule does not confer protective ability while the hydroxyphenyl group appears to be one of the determining factors.

EFFECT OF ANESTHETICS ON CELL RESPIRATION.

BY J. F. McCLENDON.

(From the Physiological Laboratory, University of Minnesota Medical School, Minneapolis.)

Owing to the difficulties encountered in keeping the metabolism down to the basal level in higher animals, comparative studies in metabolism are desirable. In choosing an animal for such investigations the jellyfish *Cassiopea xamachana* was decided on since the automatic activity of the nervous system may be abolished by cutting off the margin of the bell. The respiration rate is independent of the oxygen tension except at extremely low tensions of oxygen. In determining the rate of respiration, four jellyfish of large size (up to 15 cm. diameter) were deprived of manubrium and bell-margin and placed in a water-tight jar of about a liter capacity and rotated in a thermostat (kept at 30°) for 1 hour. The jar was filled up with sea water of known O₂ and CO₂ content, with the exclusion of air bubbles. The O₂ was determined by the Winkler method and the CO₂ calculated from the alkaline reserve and pH. It was found that the nervous conduction in the bell was anesthetized by 0.5 per cent ether. The jellyfish died at the end of 1 hour in 3 per cent ether, and in less than 1 hour in 4 per cent ether. The respiratory quotient

was found to be about 0.95, and since the oxygen could be determined more accurately than the CO_2 only the former will be given. The respiration was measured for 1 hour before anesthetization as a control.

	Oxygen (O_2).								
	0.5 per cent.	1 per cent.				2 per cent.		3 per cent.	4 per cent.
	cc.	cc.	cc.	cc.	cc.	cc.	cc.	cc.	
Ether	2.60	2.40	1.80	2.70	1.80	2.20	1.20	1.20	
Control	2.65	2.40	1.80	2.65	2.20	2.10	1.20	2.05	

Within the limit of error of the apparatus the O_2 consumption was the same with or without ether, up to 4 per cent in which the jellyfish died before the end of the hour. Carbon dioxide is sometimes considered an anesthetic for marine animals. The following experiments were made by adding CO_2 to sea water of 0.0025 N alkaline reserve and determining the pH at the beginning and end of the experiment and recording the mean value. The pH for the control was always 8.15.

	Oxygen (O_2).				
	pH 6.60.	pH 6.30.	pH 5.80.	pH 5.70.	pH 5.50.
	cc.	cc.	cc.	cc.	cc.
After CO_2	2.00	1.85	1.90	0.70	0.40
Control	1.08	2.05	2.60	1.70	1.70

The addition of CO_2 reduced respiration, but the question arises whether the undissociated CO_2 molecules or the H ions were responsible for this effect. In the following experiments no CO_2 was added to the sea water, but HCl was added thus changing the character of the ionization of the "total CO_2 " already present, as indicated by the change in pH. The pH of the control was 8.15.

	Oxygen (O_2).	
	pH 6.60.	pH 5.80.
	cc.	cc.
After HCl	2.02	1.30
Control	2.07	1.85

These experiments show that the CO_2 liberated from the carbonate and bicarbonate by the addition of HCl lowers the metabolism slightly. In order to show the possible effect of change in pH without increasing undissociated CO_2 , acid was added to sea water and the CO_2 expelled. The pH was 5.8, and 2.9 cc. of O_2 were used as compared with a control of 2.7 cc. of O_2 in normal sea water of $\text{pH} = 8.15$. Since this is within the limit of error of the apparatus we presume that the H ions were not responsible for the inhibitory effect of CO_2 on respiration of the cells covering the surface of the bell of the jellyfish.

A METHOD OF INCREASING THE SHARPNESS OF THE TONE-MINIMUM IN MEASURING THE ELECTRIC CONDUCTIVITY OF CELLS.

By J. F. McCLENDON.

(From the Physiological Laboratory, University of Minnesota Medical School, Minneapolis.)

In measuring the electric conductivity of salt solutions, the sharpness of the tone-minimum is increased by shunting a condenser across the resistance box. Variable condensers sold for that purpose have a maximum capacity of about 0.003 microfarads. Our conductivity cell, when filled with distilled water, has a capacity of less than 0.003 microfarads and a condenser of that capacity may be used with it. When filled with blood, however, such a condenser is entirely inadequate, and owing to the great cost of large variable condensers a home-made apparatus was constructed to increase the sharpness of the tone-minimum. Since this title was sent in, however, we have found that a variable condenser may be built up of telephone condensers at a moderate cost. When our cell was filled with blood a capacity of 1.3 microfarads was required across the box, whereas on the addition of saponin to lake the blood a capacity of 2.2 microfarads was required.

RELATION BETWEEN CHOLESTEROL AND CHOLESTEROL ESTERS IN THE BLOOD DURING THEIR ABSORPTION.

By ARTHUR KNUDSON.

(From the Laboratory of Biological Chemistry, Union University, Medical Department, Albany Medical College, Albany.)

A series of experiments were carried out on dogs, feeding them cholesterol and cholesterol esters, respectively, to determine the relation between the two in the blood during their absorption. In a previous paper, it was shown that, during absorption of a neutral fat (olive oil), there was a marked increase of the cholesterol esters in both the plasma and the corpuscles but no significant change in the total cholesterol.

Cholesterol was determined by the Bloor method, and cholesterol esters by the Bloor and Knudson method. In all the experiments, fat was excluded from the diet. Five experiments were studied in which from 3 to 4 gm. of cholesterol were fed to dogs, and blood specimens taken every 2 hours up to 8 hours after feeding. There was found to be a marked rise in the total cholesterol both in the plasma and in the corpuscles, and in three of the five experiments the increase in the corpuscles was greater. The amount of cholesterol in the combined form as esters remained constant throughout these experiments, indicating that the cholesterol was absorbed in the free form. In a series of four experiments feeding cholesterol esters (such as palmitate, stearate, and oleate) similar increases of the total cholesterol of the plasma and corpuscles were obtained. In three of the four experiments, the increase in total cholesterol was greater in the corpuscles. There was no change in the cholesterol esters in these experiments, indicating that the cholesterol esters must have been hydrolyzed probably in the intestines before being absorbed and that they did not combine again before entering the blood.

THE FORMATION OF ACETONE BODIES FOLLOWING ETHER
ANESTHESIA AND THEIR RELATION TO THE
PLASMA BICARBONATE.

By JAMES J. SHORT.

*(From the Laboratory of Pathological Chemistry, New York Post-Graduate
Medical School and Hospital, New York.)*

A study of the acetone bodies of the blood and urine was made in twelve cases with the gravimetric methods of Van Slyke and Fitz for blood and Van Slyke for urine. The blood content was but little affected during an average period of 48 minutes of ether anesthesia, but in two cases examined at intervals over a longer period there was a slight increase a few hours later and an increased output in the urine. The CO₂-combining powers in these cases increased even during increase of β -hydroxybutyric acid.

Experimental data indicate that fat in the presence of ether and ether itself may interfere with the accuracy of the method, since both may form a precipitate with the reagents and thus increase the weight of the precipitate formed from the acetone bodies. It could not be shown from analyses on postoperative blood specimens that ether directly effected much error, but through its ability to penetrate the filter it apparently carried with it some fat in solution which caused the increase. Glycerol formed a comparatively large precipitate with the reagents, oleic acid a much smaller precipitate.

It was concluded that, in the cases reported, acetone bodies were not formed promptly enough during ether anesthesia to account for the decreased plasma bicarbonate and that results of analyses for β -hydroxybutyric acid on postoperative bloods may in some instances have been too high, due to an error introduced as a result of the ether content.

PROPERTIES OF HEMOCYANIN AS AN ANTIGEN.

BY C. L. A. SCHMIDT.

(From the Department of Biochemistry and Pharmacology, University of California, Berkeley.)

Hemocyanin obtained from the abalone was found to be precipitated by ammonium sulfate within the limits given by Alsberg for that obtained from *Limulus*. On repeated injections into rabbits, positive fixation and precipitin tests were obtained. The substance in moderate doses is non-toxic for guinea pigs.

ENERGY ELIMINATION AND GASEOUS EXCHANGE IN BANANAS, PINEAPPLES, AND APPLES.

BY C. F. LANGWORTHY, R. D. MILNER, AND H. G. BAROTT.

(From the Office of Home Economics, States Relation Service, United States Department of Agriculture, Washington.)

The changes in ripening fruit are due to enzymes normally present in the fruit and vary with the condition of the surrounding atmosphere in respect to heat, light, water vapor, and other gases. The practical improvement of storage conditions can best be secured by exact knowledge of the biological changes in the materials stored, which in turn implies an increased knowledge of the atmospheric factors just mentioned. The respiration calorimeter in this laboratory is well adapted for the study of such problems and has been used in experiments with apples, bananas, and pineapples. The bananas and pineapples were in the state known in the trade as "active ripening" while the apples were a Fall variety, recently harvested for storage for winter use.

The following table summarizes the results.

Hourly Energy Elimination and Gaseous Exchange per Kilo of Fruit Stored at Room Temperature (10-30°C.).

Fruit.	Energy.	Oxygen.	Carbon dioxide.	Water vapor.	Specific heat.
	<i>cal.</i>	<i>liters</i>	<i>gm.</i>	<i>gm.</i>	
Bananas	0.31	0.06	0.12	0.35	
Pineapples.....	0.19	0.03	0.07	0.14	
Apples	0.04				0.93

That the changes thus measured are of considerable magnitude appears from a comparison with the energy elimination of the human body at complete rest, which is estimated as 1.1 calories per kilo per hour.

INDICAN IN THE SALIVA OF A CASE OF PELLAGRA COMPLICATED WITH TUBERCULOSIS.

BY M. X. SULLIVAN.

(From the Pellagra Hospital, United States Public Health Service, Spartanburg.)

The urine of many of the patients at the hospital was found to contain a high content of indican. Tests were made on the saliva to see if indican could be found therein, using the Obermayer reagent and extracting with chloroform. In Case 313 with large amounts of indican in the urine indican was found likewise in the saliva in two tests. Once the chloroform was blue with indigo blue and once red with indigo red. No other saliva showed the presence of appreciable amounts of indican. It may be noted that shortly after the discovery of indican in his saliva, Case 313 was judged to be suffering from tuberculosis also, from which disease he died about a month later. What part the tuberculosis played in the presence of indican in the saliva cannot be told.

BIOCHEMICAL STUDIES OF THE SALIVA IN PELLAGRA.

BY M. X. SULLIVAN AND K. K. JONES.

(From the Pellagra Hospital, United States Public Health Service, Spartanburg.)

In pellagra the condition of the mouth, and especially of the tongue, is of considerable importance in establishing a correct diagnosis. The true pellagrous tongue is vividly red and more or less swollen. The literature also speaks of salivation as a symptom of pellagra. In careful quantitative studies at the Pellagra Hospital, Spartanburg, South Carolina, some interesting data were gathered on the saliva in pellagra. It was found that, though there were cases of increased salivary flow, the salivation spoken of by the patients was often apparent rather than real

and was seemingly due to some inhibition of swallowing combined with a peculiar ropy change in the saliva or a high content of mucus which made the presence of saliva in the mouth more obvious. Occasionally also the flow was very slow, but in general it was within normal limits which vary considerably. The specific gravity of the saliva of the pellagra patients tended to be higher than that of the controls. The total solids, ash, organic matter, and mucin of the saliva was greater for the pellagrins than for the controls, but bore no relation to the mouth symptoms. The diastatic power of the saliva of pellagrins varied within the limits established by the controls. The sulfoeyanate content was much less marked in the saliva of the pellagra patients than in that of normal people. The reaction of the saliva in pellagra was found to be somewhat more alkaline than that of normal saliva.

IS FIBRINOGEN FORMED IN THE LIVER?

BY A. P. MATHEWS.

THE ANTIKETOGENIC ACTION OF GLUCOSE.

BY P. A. SHAFFER.

A NEW QUALITATIVE AND QUANTITATIVE COLOR REACTION FOR AMINO-ACIDS.

BY OTTO FOLIN AND H. WU.

ON THE DETERMINATION OF BLOOD SUGAR.

BY S. R. BENEDICT AND ELIZABETH FRANKE.

A CONVENIENT PERMANENT UREASE PREPARATION.

BY OTTO FOLIN.

ON THE LIPINS OF HUMAN CORPUS LUTEUM.

BY JACOB ROSENBLOOM.

OBSERVATIONS ON THE CHEMICAL PATHOLOGY OF THE BLOOD IN PERNICIOUS ANEMIA.

BY AMOS W. PETERS AND A. S. RUBNITZ.

THE EFFECTS OF MODERATE HEMORRHAGE, ETC., ON SOME OF THE BLOOD ELEMENTS AND CONSTITUENTS.

BY E. S. SUNDSTROEM AND W. R. BLOOR.



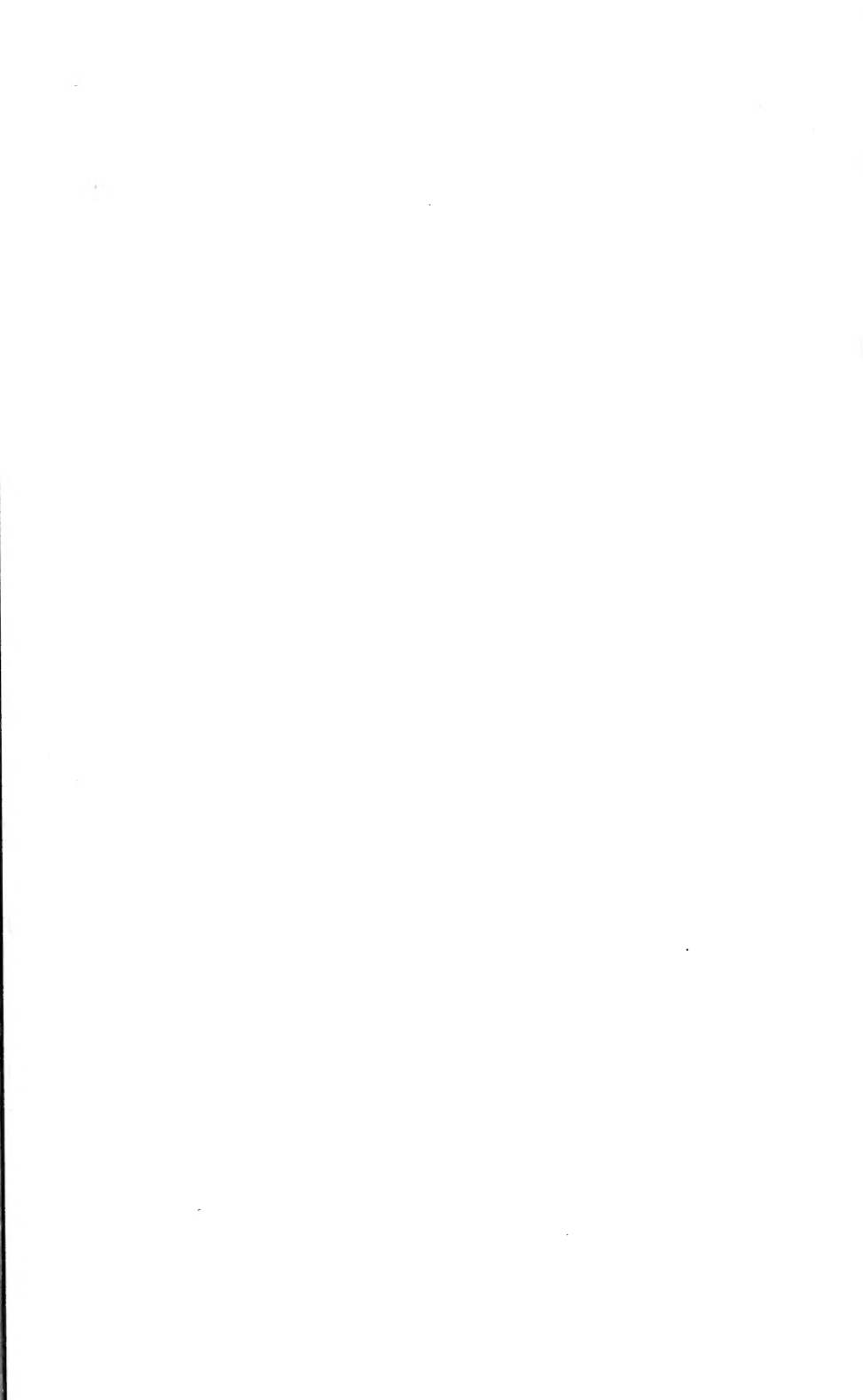

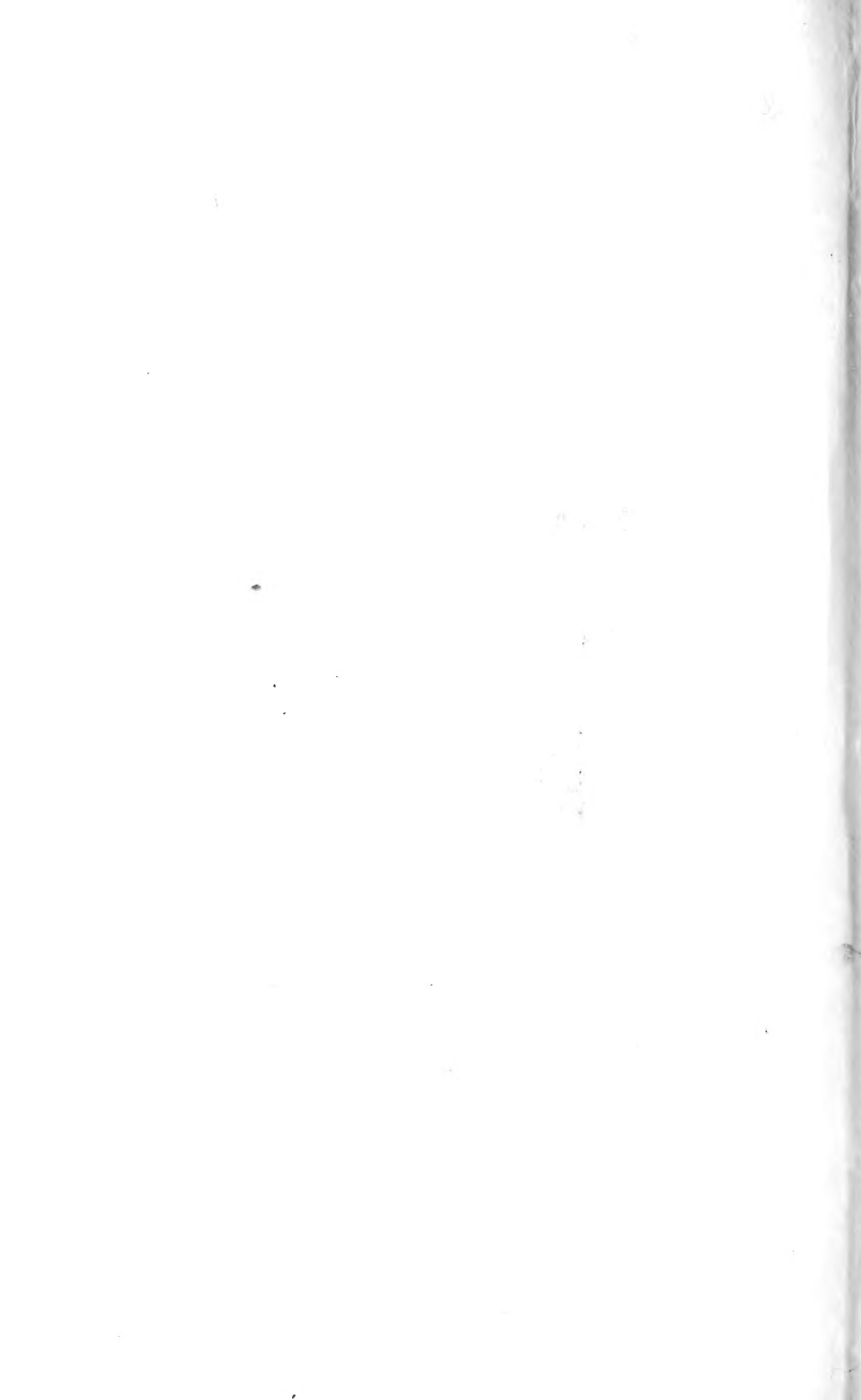

QP
501
J77
v.40-41
cop.2

The Journal of biological
chemistry

(1919)

Biological
& Medical
Serials

PLEASE DO NOT REMOVE
CARDS OR SLIPS FROM THIS POCKET

UNIVERSITY OF TORONTO LIBRARY

