

223.8

Library of the Museum
OF
COMPARATIVE ZOÖLOGY,
AT HARVARD COLLEGE, CAMBRIDGE, MASS.

The gift of the *Elisha Mitchell*
Scientific
Society
No. *11, 726*
Jan. 31 - Dec. 31. 1888.

JOURNAL

OF THE

Elisha Mitchell Scientific Society,

VOLUME IV ---PART I.

JANUARY--JUNE 1887.

PUBLICATION COMMITTEE:

R. H. GRAVES,
J. A. HOLMES,
J. L. LOVE.

PERMANENT SECRETARY:

F. P. VENABLE, - - - - - CHAPEL HILL, N. C.

TABLE OF CONTENTS.

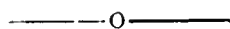

| | PAGE. |
|---|-------|
| Officers..... | 4 |
| Report of the resident Vice-President for the year 1886-87..... | 5 |
| Report of the Secretary..... | 8 |
| Treasurer's Report..... | 12 |
| A Sketch and Bibliography of Nicholas Marcellus Hentz..... | 13 |
| A New Trap-door Spider..... | 16 |
| A Family of Young Trap-door Spiders..... | 26 |
| Some new Salts of Camphoric Acid..... | 52 |
| Decomposition of Potassium Cyanide..... | 54 |
| Lead Chlor-Sulpho-Cyanide..... | 55 |
| Solability of Alumina in Sulphuric Acid..... | 56 |
| Analysis of Water from the Artesian Well at Durham, N C..... | 57 |
| The Fertilizer Trade in North Carolina in 1886..... | 58 |
| List of Exchanges..... | 66 |

JOURNAL

OF THE

ELISHA MITCHELL SCIENTIFIC SOCIETY.

REPORT OF THE RESIDENT VICE-PRESIDENT
FOR THE YEAR 1886-'87.

J. A. HOLMES.

The Society has now completed the fourth year of its existence. And the result of its work during the past year, and of the three years preceding, afford the assurance that it may be now regarded as a permanent institution. Kind words of encouragement have come in from eminent sources; applications for the Journals of the Society have increased in number; the society has now on its exchange list Journals of many of the more prominent societies of the United States, and of several foreign societies; and there has been a steady improvement in the extent and character of the original investigations being carried on by members of the Society.

It is worthy of mention, too, that the system of public lectures which was inaugurated at the State University by this Society has been adopted by other institutions in this and adjacent States. And the Secretary of this Society has been in correspondence with gentlemen connected with other Southern institutions who intend organizing similar Societies. We may believe, then, that this humble beginning made here less than four years ago, is doing something to awaken a new activity in scientific work not only in our own State but also in other Southern States.

The following summary will exhibit in a general way the

work of the Society during the past four years of its existence :

| | 1883-'84 | '84-'85 | '85-'86 | '86-'87 | Totals |
|-----------------------|----------|---------|---------|---------|--------|
| Meetings, | 6 | 5 | 8 | 9 | 28 |
| Public Lectures,..... | — | 4 | — | 3 | 7 |
| Papers presented..... | 67 | 43 | 60 | 53 | 223 |
| Papers published..... | 98 | 100 | 148 | 150* | 500 |

The above table shows a decrease in the number of papers presented; but there has been a decided improvement in the length and value of the papers, that has more than counter-balanced the falling off in number. The Journal for 1886 and 1887, which is to be published in two parts, will probably contain more papers than is indicated above. A detailed statement would show more clearly the growth of the Society; but this can not be given here.

But while the Society is making real advancement it is doing so under disadvantages. Its membership has not been increased as was hoped it would. The students and graduates of the University and other institutions have not associated themselves with it, nor have taken part in its work as it was expected they might, and as it is hoped they will do in the future. Nor has the Society received the liberal financial support which it needs to increase the publication of its Journals. The Society needs in every way a more generous support; and for this it must appeal to its members and all others interested in scientific work in the State.

Among the present and pressing needs of the Society I may mention the following :

(1) The hearty co-operation of a much larger number of persons in the State engaged in, or interested in, scientific work. All such should become members of the Society and co-operate with it in its work.

(2) A more liberal financial support. During the past year for want of funds the Society was unable to publish several papers presented for publication in the Journal. Among the members of other Societies are often to be found men of wealth and liberality who contribute largely to the financial support of the Societies to which they belong, and have won the title of "patrons" of the Society. A few members of the Mitchell Society have contributed liberally to its

*Number of pages estimated—not yet published.

financial support during the past year; and it is earnestly hoped that this membership will increase.

(3) Contributions to the Library of the Society. During the past few months an encouraging beginning has been made in this direction, and it is hoped that much more will be accomplished during the coming year. The Society desires to collect together for preservation and reference, all books, pamphlets, manuscripts, maps, &c., that have any bearing upon the history, natural history, or resources of North Carolina, and any books, pamphlets, maps, &c., written by members of the Society, or workers in North Carolina. Already there has been collected together upwards of 400 such books, pamphlets and journals of other Societies.

A system of public lectures was organized again during this year, and three lectures have been given. These will be continued during the next year under the direction of the council.

The Journal of the Society for 1885-'86, published during the past year, was a pamphlet of 148 pages. The Journal for 1886-'87 will be published in two parts of probably 75 pages each. Part I will be printed during the early summer. Part II will appear later in the year.

As a continuation of the series of biographical sketches Part I of the Journal will contain a short sketch of Prof. Marcellus Hentz. Part II will contain a sketch of the late Prof. W. C. Kerr.

The President of the Society, on account of ill health, has been unable to meet with the Society during the year; but in various ways he has given assistance and encouragement.

During the year one death has occurred among the Life Members of the Society: Right Rev. Wm. M. Green, Bishop of Mississippi, and one among the regular members, Col. J. B. Wheeler.

JOURNAL OF THE
REPORT OF THE SECRETARY.

F. P. VENABLE.

BUSINESS MEETINGS.

AUGUST 28, 1886.

Prof. Holmes in the chair. The date of the public meetings was changed to the second Tuesday in each month. The condition of the Treasury was discussed and the Treasurer was directed to advertise and place on sale the new Journals.

OCTOBER 15, 1886.

Prof. Holmes presided. It was directed that papers presented before the Society be, as far as possible, on uniform paper, as to size at least, and that the Publication Committee take charge of the papers immediately after each meeting, deciding which are to be published and which placed on file, finally placing them in the hands of the Secretary.

Arrangements were directed to be made for storing the books and pamphlets belonging to the Society where they would be convenient for reference.

A Committee was appointed to take steps towards effecting an interchange of publications with other bodies having a like aim with this Society.

MAY 7, 1887.

Prof. Holmes in the chair. The Secretary and Treasurer presented his reports.

It was ordered that the monthly bulletins containing abstracts of papers read at the public meetings be issued also during the coming year.

In view of this increase of the Secretary's duties and of the rapidly growing library of the Society the office of Recording Secretary and Librarian was created,

By a vote of the Society the office of Corresponding Secretary was made permanent.

To insure more rapid publication of the material on hand it was decided that hereafter the Journal be published in two semi-annual parts.

The following officers for 1887-1888 were then elected:

- PRESIDENT—Dr. R. H. Lewis, Raleigh, N C.
 VICE-PRESIDENTS—Prof. W. L Poteat, Wake Forest College, and Dr. W. B. Phillips, Chapel Hill.
 SECRETARY AND TREASURER—Dr. F. P. Venable, Chapel Hill.
 RECORDING SECRETARY—Prof. J. W. Gore, Chapel Hill.
 PUBLICATION COMMITTEE—Profs. Graves, Holmes and Love, Chapel Hill.

As Honorary members the following were elected :

Major J. W. Powell, U. S. Geological Survey; Hon. S. F. Baird, Smithsonian Institution, and Dr. C. V. Riley, Department of Agriculture.

As Corresponding members :

Prof. E. E. Smith, University of Alabama; Dr. D. Day, U. S. Geological Survey; Dr. J. M. McBryde, University of South Carolina, and Prof. W. J. McGee, U. S. Geological Survey.

A number of regular members were also elected, a list of whom will appear in the second part of the Journal.

PUBLIC MEETINGS.

NATURAL HISTORY LECTURE ROOM,

XX. PUBLIC MEETING. *September 14, 1886.*

1. Examination of certain North Carolina Clays,.....W. B. Phillips.
2. Treatment of Refractory Phosphates,.....W. B. Phillips.
3. Report on the last meeting of American Association for
 the Advancement of Science,.....J. W. Gore.
4. Report on recently Discovered Elements,.....F. P. Venable.
5. Report on Saccharine.....F. P. Venable.
6. New Instances of Protective Resemblance in Insects, G. F. Atkinson.
7. Report on a Recent Discovery in Biology,.....G. F. Atkinson.

XXI. PUBLIC MEETING. *November, 1886.*

8. On the Parameter of a Plane,.....R. H. Graves and W. B. Phillips.

9. Report on Arsenic as a Poison,.....F. P. Venable.
 10. A New Glow Worm,.....G. F. Atkinson.
 11. A singular occurrence of Cerusite,.....W. B. Phillips.
 12. Report on Earthquakes occurring at Charleston, from
 18th Century to present time,.....J. A. Holmes.

XXII PUBLIC MEETING.

November, 1886.

13. On Universal or Cosmic Time,.....J. L. Love.
 14. A New Lamp for Laboratory Use,.....F. P. Venable.
 15. A List of Minerals containing Phosphoric Acid.....W. B. Phillips.
 16. Subsidence along the Coast of New Jersey.....J. A. Holmes.
 17. Report on the Recession of Niagara Falls.....J. A. Holmes.

XXI PUBLIC MEETING.

December, 1886.

18. Solar Eclipses.....J. W. Gore.
 19. External Signs of Lodes and Veins,.....W. B. Phillips.
 20. Report on the Isolation of Fluorine,.....F. P. Venable.
 21. Ancient Mathematics,R. H. Graves.

XXIV PUBLIC MEETING.

January 25th, 1887.

22. Report on Isolation of Fluorine, (continued),.....F. P. Venable.
 23. Utilization of Wool Grease,.....F. P. Venable.
 24. Can an Air-bubble Function as an Organ of Respi-
 ration,.....G. F. Atkinson.
 25. Classification of Ore Deposits, .. .W. B. Phillips.
 26. Rainfall Statistics for North Carolina,.....J. A. Holmes.

XXV PUBLIC MEETING.

February 8th, 1887.

27. The True Source of the Mississippi,J. W. Gore.
 28. Nomenclature of Lodes. Beds and Veins,.....W. B. Phillips.
 29. A New Insec Epidemic,.....G. F. Atkinson.
 30. Report on Carbon Dioxide in the Air,.....F. P. Venable.

XXVI PUBLIC MEETING.

March 8th, 1887.

31. Sepulchral and Perpetual Lamps,Dr. H. C. Bolton.
 32. A New Test for Iron,.....F. P. Venable.
 33. A Madstone,W. B. Phillips.
 34. Reversion of Superphosphates when Bottled,.....W. B. Phillips.
 35. Temperature Statistics for North Carolina,.....J. A. Holmes.

XXVII PUBLIC MEETING.

April 12th, 1887.

36. A Sarcopid Mite,.....G. F. Atkinson.
 37. The New Glow Worm,.....G. F. Atkinson.
 38. Flowering of Plants in Chapel Hill section,.....L. W. Lynch.
 39. Eine Verschiebung,.....W. B. Phillips.

- 40. Harnett County Fire Clay,W. B. Phillips.
- 41. Report on the Evaporation of Water on Stoves,.....F. P. Venable.
- 42. Report on the "Genesis of the Elements,".....F. P. Venable.
- 43. Average Elevation and Rainfall of North Carolina,....J. A. Holmes.

XXVIII PUBLIC MEETING. *May 10th, 1887.*

- 44. Hetero-somatism,W. B. Phillips
- 45. Meteorology of Chapel Hill,.....J. W. Gore.
- 46. Preliminary List of Butterflies of Chapel Hill,.....A. Braswell.
- 47. Notes on Protective Resemblance in Butterflies,.....F. M. Harper.
- 48. Notes on Apple Blight,.....G. F. Atkinson.
- 49. Preliminary List of the Birds of Chapel Hill,.....G. F. Atkinson.
- 50. Action of Chlorine Monoxide on Hexylen,.....R. G. Grisom.
- 51. Action of Halogen Acids on Lead, Arsenate and
Phosphates,.....H. F. Shaffner.
- 52. Some New Lead Salts,.....F. P. Venable.
- 53. Reports of Officers for 1886-1887.

PUBLIC LECTURES.

V — MARCH 1, 1887.

- The Resurrectionists,.....F. P. Venable.

VI — MARCH 22, 1887.

- A Sketch of Mathematical and Physical Sciences from Aristarchus to Hipparchus,.....R. H. Graves.

VII — APRIL 26, 1887.

- Galilei,J. W. Gore.

TREASURER'S REPORT.

 F. P. VENABLE.

| | | |
|----------------------------------|----------|-----------|
| Balance from October 1886..... | \$ 85 57 | |
| Additional fees for 1886..... | 25 00 | |
| Additional Journals sold..... | 84 40 | |
| Special contributions..... | 85 00 | |
| Fees collected for 1887..... | 72 00 | |
| | | <hr/> |
| Printing of Journal..... | | \$ 231 85 |
| Postage..... | | 21 92 |
| Stationery..... | | 4 50 |
| Advertising..... | | 1 55 |
| Plates..... | | 22 50 |
| Freight and Expenses..... | | 2 60 |
| | | <hr/> |
| Total amount received..... | 351 97 | |
| Total amount expended..... | | 284 92 |
| Balance on hand May 15th..... | 67 05 | |
| Amount due from members..... | 56 00 | |
| Estimated sales of Journals..... | 60 00 | |
| Estimated expenses..... | | 250 00 |

It is evident from the above table that the estimated expenses run considerably beyond the probable income, and yet these expenses are placed at a much lower figure than for last year. It is therefore essential that special contributions reach the society's treasury in order that the work be maintained as heretofore.

A SKETCH AND BIOGRAPHY OF NICHOLAS MARCELLUS HENTZ.

—

N. M. HENTZ was born in Versailles, July 25, 1797. To this place his father, who was active in political affairs, had been obliged to flee from Paris, and conceal himself under an assumed name (Arnold). His son showed a remarkable talent for miniature painting while quite young, and attained considerable proficiency in this art. In 1813 he entered the Hospital Val de Grace as a student in medicine, where he remained busied with his studies and duties as hospital assistant until the fall of Napoleon. At this time his father was proscribed and obliged to flee to America.

The family, after their arrival in this country, spent a few weeks in New York City and Elizabeth Town, when they removed to Wilkesburg, Pa., the latter part of April, 1816.

For some years Hentz was engaged in Philadelphia and Boston as teacher of French and miniature drawing. Following this, for a short time he was tutor in the family of a wealthy planter (Mr. Marshall) on Sullivan's Island, near Charleston, S. C.

While engaged as a teacher in a school for boys at Round Hill, Northampton, Mass., he was married to Miss Caroline Lee Whiting, the daughter of Gen. John Whiting, of Lancaster. His wife afterwards became well known as a poet and novelist.

Soon after his marriage, in 1824, he moved to Chapel Hill, N. C., where he had charge of Modern Languages in the State University until 1830. From this time up to 1849, he was in charge of various female seminaries and academies in the South; at Covington, Ky., Cincinnati, O., Florence, Tuscaloosa, and Tuskegee, Ala., and Columbus, Ga. His health having failed, he moved to the residence of his son Charles, at Mariana, Florida; where he died Nov. 4, 1856.

It is a remarkable fact that during his long life as a teacher he was one of the pioneers in American Entomology, and became during his time the highest authority on American Spiders. His life and work then are of special interest to the members of the Mitchell Society because of his connection with the University of North Carolina. All of his leis-

ure hours, during his life as a teacher, were devoted to these studies.

He was an intimate friend and co-worker with the well known entomologist, Harris, as the publications of the Boston Society of Natural History will testify.

He was very fortunate in selecting the spiders as his special field of study, for little or nothing at that time had been published on North American Spiders. His time was given to the observation of their habits, and to the collection, description and representation of the various species. He published a few papers in Silliman's Journal, and in the Journal of the Philadelphia Academy of Arts and Sciences, and then brought together his extensive series of notes and paintings, and offered them to the Boston Society of Natural History for publication in its Journal. The publication of these extended over a number of years. A few years ago, as many of the publications were out of print, the Council of the Society determined to republish, in a connected form, all of Hentz's arachnological writings. When this was done, a considerable number of notes and descriptions were added by Mr. J. H. Emerton, who has paid much attention to our native spiders. A few notes were also added by Mr. Wm. E. Holden of Marietta, O.

After Hentz's death, his collection of spiders went into the hands of the Boston Society, but has since been nearly destroyed.*

G. F. ATKINSON.

LIST OF THE WRITINGS OF PROF. HENTZ.

1821. A notice concerning the spider whose web is used in medicine (*Tegenaria medicinalis*) Jour. Phil. Acad. Nat. Sci., II., p. 53-55.

1825. Some observations on the Anatomy and Physiology of the Alligator of North America. Trans. Am. Phil. Soc., II., pp. 216-228.

1825. Description of some new species of North American Insects. Jour. Phil. Acad. Nat. Sci., V. pp. 373-375.

1829. The same paper in Férussac's Bulletin des Sciences Naturelles, XVIII., pp. 475-476.

1830. Description of eleven new species of North American Insects. Trans. Amer. Soc., III., pp. 253-258.

* The Spiders of the United States by Nicholas Marcellus Hentz, M. D. Occasional Papers of the Boston Society of Natural History, II, Preface

1830. Remarks on the use of the Maxillae in Coleopterous insects, with an account of two species of the family Telophoridae (*Chaulognathus marginatus*, and *C. bimaculatus*), and three of the family Mordellidae (*R. lepi-phorus dimidiatus*, *R. limbatus* and *R. tristis*) which ought to be the type of two distinct genera. *Ibid.* pp. 458-463.

1832. On North American Spiders. Silliman's Journal of Science and Arts. XXI., pp. 99-152.

1833. Enumeration of the Spiders of the United States. Hitchcock's Report on Geology, etc., of Massachusetts. p. 564, (contains only the list of genera published in the preceding paper).

1835. List of Spiders of the United States. *Ibid.* Second edition. (This edition enumerates one hundred and twenty-five species, mostly by name, and arranged under the genera given in the first edition. The species are those described in the Journal Bost. Soc. Nat. Hist.)

1841. Description of an American Spider (*Spermophora meridionalis*) constituting a new subgenus of the tribe Inæquitæ, Latreille. *Ibid.* XLI. pp. 115-117.

1841. Species of Mygale of the United States. Proc. Bost. Soc. Nat. Hist., I. pp. 41-42.

1842. Description and Figures of the Araneides of the United States. Journal Bost. Soc. Nat. Hist., IV., pp. 55-57. Pl. 7. Continuation, pp. 223-231. Pl. 8.

1844. Continuation, *ibid.*, pp. 386-396. Pl. 17-19.

1845. Continuation, *ibid.*, V., pp. 189-202. Pl. 16, 17.

1846. Continuation, *ibid.*, pp. 352-369. Pl. 21, 22.

1847. Continuation, *ibid.*, pp. 444-478. Pl. 23, 24, 30, 31.

1850. Continuation, *ibid.*, VI., pp. 18-35. Pl. 3, 4. Conclusion, pp. 271-295. Pl. 9, 10.

1867. Supplement to the Description and Figures of the Araneides of the United States. Edited by S. H. Scudder. Proc. Bost. Soc. Nat. Hist., XI., pp. 103-111, with two plates.

NOTE.—This list is taken from "Occasional Papers of the Bost. Soc. Nat. Hist., II. The Spiders of the United States by N. M. Hentz, M. D.

G. F. ATKINSON.

A NEW TRAP-DOOR SPIDER.

BY GEORGE F. ATKINSON.

In his excellent work on trap-door spiders, Mr. Moggridge says, "There would doubtless be a just feeling of pride and satisfaction in the heart of a naturalist, who could say that he had made himself thoroughly acquainted with all the species of a particular group of animals, had learned their most secret habits, and mastered their several relations to the objects, animate and inanimate, which surrounded them. But perhaps a still keener pleasure is enjoyed by one who carries about with him some problem of the kind but partially solved; and who, holding in his hand the clue which shall guide him onwards sees in each new place that he visits fresh opportunities of discovery. The latter is certainly the condition of those who take an interest in searching out the habits and characters of trap-door spiders."¹

While many interesting facts, in the life history, and architecture of trap-door spiders were observed and collected by Mr. Moggridge, he very modestly says that many remain yet to be gathered in; that we are only on the threshold of discoveries of these creatures who have lain quiet in the earth century after century; and that he will be satisfied to have been able to "hold the door sufficiently ajar to permit those who love nature and her ways to catch a glimpse of the wonders and beauties of the untrodden land that lies beyond."²

A favorable circumstance afforded me an opportunity for making some observations on the unseen "wonders and beauties of the untrodden land" which is the abode of these interesting creatures, and it is with a sense of pleasure that I note them.

Some time the latter part of May, or early part of June,

¹Harvesting Ants and Trap-Door Spiders. Supplement, p. 180.

²Harvesting Ants and Trap-Door Spiders, p. 136.

1885, Mr. Merritt, of Pittsboro, N. C., brought to Chapel Hill, two trap-door spiders with their nests, and placed them in the care of Prof. Holmes, for the University of North Carolina. The nests with their occupants were placed in the ground for the summer. On Nov. 12, after a careful search Prof. Holmes was able to find only one, and this one with difficulty, as for some reason it had dug through the lower end of the tube and was hidden in the earth. Later I shall offer what seems to me may be an explanation of this. On the morning of the same day, the spider with its trap-door nest was placed in my keeping, which was the first intimation I had of the presence of such an agreeable neighbor.

At 4:30, p. m., I placed $3\frac{1}{2}$ inches of earth in a glass jar 5 inches in diameter and 7 inches deep. Two thirds of the surface of the soil was then covered with moss. In this the spider was placed, and the jar and its contents taken to my room, that I might, if possible, observe the operation of digging the tube and making the trap-door.

The results were most gratifying. Just before going to supper, at dusk, I observed that the spider had not undertaken the work. Upon returning at 8:30, p. m., I found the task undertaken. The spider was resting in a hole about 20^{m.m.} deep by 22^{m.m.} in diameter, which she had excavated at one side of the jar. I placed the jar upon my study table, just beneath the light of a student lamp, so that while reading I could observe any movements made by my companion. The spider was resting in the hole with its legs partially folded, the anterior ones lying upon the edge of the excavation.

After I had been quiet for some time the spider began to move cautiously, and turning about slowly, went head first into the hole, and dug from the bottom with her mandibles a pellet of earth about the size of a small pea. Then turning carefully around she placed it at the edge of the hole where she pushed it off with aid of her palpi, at the same time working her mandibles up and down. At first the spider seemed timid, and would cease operations upon the slightest movement on the part of myself. During the course of the evening three other persons who came to my room had the fortune to witness the operation of digging out the earth. The spider soon became bold, paid no attention to movements in the room, and permitted me to watch her very closely. Occasionally, by using both palpi at once, the dirt was flung suddenly from the grasp of the mandibles

with such force as to strike against the opposite side of the jar. Had it not been for this obstruction the dirt must have been thrown three or four feet.

After depositing each load on the edge of the hole the spider would turn around again for another load, but before picking it up, she would project the posterior pair of spinnerets about 5^{m.m.} from the abdomen, and carefully knead the viscid liquid upon and around the freshly placed pellet of earth, and over the edge for a distance of 4^{m.m.} or 5^{m.m.}, for the purpose of making the soil adhere and prevent its caving in. In Plate I, Fig. 4, the spider is shown in the act of removing a pellet of earth from her mandibles. In Fig. 5, is represented the application of the viscid liquid. The ends of the spinnerets are applied to the surface alternately, as shown in the illustration. The legs took no part in the application of the viscid liquid; nor did the liquid form a thread when the spinnerets were drawn from the surface, as I have since seen it when the spider was crawling about on the surface of the earth.¹

At 11:30 o'clock, when the hole was about 4^{m.m.} in depth, to my surprise and pleasure the spider began to make the "trap-door." Standing upon its fore feet and placing the spinnerets against the glass jar at the level of the edge of the hole, the spider covered the glass with the viscid liquid. Several pellets of earth were stuck to this, each time another portion of the viscid liquid being applied. After a depth of 5^{m.m.} had been built up in this way, which was to answer as the hinge, the spider cut a sprig of the moss and cemented it to the hinge so that the end projected above it. Small sticks, particles of moss and earth were constantly placed upon the edge of the growing door. Each time the spider would come out of the hole for new material, retreat backward, and turn half way around so as to apply it to the door. Placing the load on the under side of the partial door, she would carefully move it up to the edge. Then placing the distal portion of the palpi and anterior pair of legs above, while the proximal portion of these limbs and the ends of the mandibles were on the under side of the pellet and door, she would

¹As I am now writing, Jan. 16, 1886, 11:55, p. m., the spider is crawling about on the surface of a freshly prepared jar of earth. Sometimes the viscid liquid adhering to some object is drawn out in a band of silk 2^{m.m.} wide, and the pieces of moss strewn on the earth are loosely matted together in the path of the spider about the side of the jar.

fit and press it in shape, as one would mold with the hand a moist portion of earth by pressing it into a thin sheet. This is illustrated in Fig. 7, Plate XXII. Indeed it looked very much like the black bony fingers of a hand performing the work of pressing. The greatest pressure seemed to be brought to bear upon the rounded ends of the mandibles. After fastening on a portion thus, the spider would take an inverted position and apply viscid liquid along the edge and under surface of the door, as shown in Plate XXIII, Fig. 6. She would then turn about and crawl out for more material. The hole being by the side of the jar, I could watch the operation both in the hole and upon the cover. By 1 o'clock in the morning (Nov. 13,) the door was finished so that the spider could pull down the lid, which completely closed the entrance, nicely fitting in around the edge and appearing as if there was no hole nor spider, but through the glass the spider could still be seen.

At intervals during the construction of the door, the spider would pull it down to observe where the next pellet should be placed in order to make the door fit the circular opening of the tube. Discovering this she would turn completely around, and not being able with her head in the bottom of the tube to see the place where she intended to put the next load, she would find it by feeling about with her spinnerets. The viscid liquid would then be applied and the pellet of earth fitted with extreme nicety. Satisfied with the result of my experiment I retired.

By daybreak I found that the excavation was continued after the completion of the trap-door, the soil being deposited around the nest to raise the surface of the earth in the jar to a level with the top of the nest. Without close searching it was impossible to detect the door.

The mode of making the trap-door by this spider differs very widely from that observed by other naturalists so far as I can find any record. Mr. Moggridge saw the female, *Nemesia Meriodinalis*, construct a trap-door in captivity. He made a cylindrical hole in a flower-pot of earth. Into this the spider disappeared. "During the night following the day of her capture she made a thin web over the aperture, into which she wove any material which came to hand. The trap-door at this stage resembled a rudely constructed, horizontal, geometrical web, attached by two or three threads to the earth at the mouth of the hole, while in this web were caught the bits of earth, roots, moss, leaves, etc., which the

spider had thrown into it from above. After the second night the door appeared nearly of the normal texture and thickness, but in no case would it open completely, and it seemed the spider was too much disgusted with her quarters to think it worth while to make a perfect door."¹

He also records the making of a door by a very young one of this species, in which the threads, except at the hinge, were cut so that the door would open and shut.²

The only thing he records which seems at all analagous to the mode of making a trap-door exhibited by the spider in my possession is that manifested in the enlargement of nests and trap-doors by spiders as they grow larger, and consequently require nests of larger dimensions. This operation was not witnessed by him, however, but the additions to the size of the door were proven by measurements and observations upon nests of young spiders at different seasons.³

It would seem natural to suppose that, in making slight additions from time to time to the edge of the nest, the spider would cement pellets of earth, pieces of moss, etc., to the edge, instead of first spinning a web; unless the web is spun over the lower side of the door and made to project just far enough to fit the enlarged tube. In Plate XXIII, Fig. 8, can be seen eight concentric "lines of growth," as they might be termed, of the trap-door, corresponding to the growth and needs of the spider. These I judge to represent the successive enlargements of the door concomitant with the enlarging of the tube. We can safely say that these additions were made by cementing the material, piece by piece, which forms each ring, to the edge of the door. These "lines of growth" are not present in the door made by the adult spider in captivity. I induced the spider to make the door the fourth time, (Jan. 19, 1886,) in order to observe if there was any regularity in the cementing of the particles, which might form these lines of growth in a door made by an adult spider. There is no such regularity. Indeed his last door was made of about a dozen very large pellets of clay, which, being very plastic, the spider was able to press each pellet into a sheet of considerable dimensions.

It is to be regretted that Mr. Moggridge did not have the

¹Harvesting Ants and Trap-Door Spiders, p. 118.

²Harvesting Ants and Trap-Door Spiders, p. 119.

³Idem. pp. 123, 127 and 150, and Supplement, p. 245.

opportunity of observing the manner of enlargement of trap-doors made by the spiders which he studied, or that he did not offer some theory as an explanation. If the particles are cemented to the edge, it would be quite natural that the species of spider in my possession once made its door by first spinning a web across the mouth of the tube, and then weaving into it other material, as in the case of *N. meridionalis*; and that the habits, followed through life and successive generations, of making additions to the door by cementing particles to the edge, finally became so fixed that this mode of making additions to it became the permanent habit and type of construction of the trap-door from the foundation! The rapidity, ease, and intelligence manifested in this method of building up the door, piece by piece, certainly indicates a higher development of instinctive power. A perfect and neatly fitting and swinging door made in 1½ hours!

When I took the spider from her nest it was necessary to remove nearly all of the soil from the jar and take her from the lower end of the tube, as all efforts to attract her from the nest failed. As the soil was very loose and the nest not long made the walls of the tube collapsed. In ten days the spider was returned to the nest. Though the trap-door was capable of being used, and seemed to satisfy the spider's idea of the "fitness of things," it was in a very dilapidated condition. This agrees with what Mr. Moggridge says of the reluctance manifested by spiders to abandon an old nest. The examples cited by him are that if a door be pinned back, during the night a second door will be made; that if the nest be covered with earth the tube will be prolonged to the surface of the superimposed earth and a new trap-door will be made; and that in some cases nests become inverted, when, a door being made at the now upper end of the tube, the nest will have a door at each end!¹ The conduct of my spider under another condition farther illustrates this feature. Wishing to observe the habit of the spider if possible while the door of the nest was closed, I prepared a glass test tube, 17^{m.m.} in diameter by placing, 4^{cm} from the mouth, a cork bottom, so that the spider might have something on which to stand while making the door. This, with the spider in it, I placed in the glass jar and surrounded it with earth to darken the walls, hoping thus, because of the firm smooth surface of the tube she would not line it with silk, and by

¹Harvesting Ants and Trap-Door Spiders, pp. 121 and 122.

lifting the tube from the soil I could observe the position of the spider as it held down its door. The experiment was a decided success.

This was prepared at eleven o'clock on the night of Dec. 27, '85. Pieces of moss were strewn about the tube. By morning a perfectly fitting door, beautifully covered with moss had been constructed (Plate XXIV. Fig. 3). About this time many visitors came to see the spider, and in pulling at the door to show how persistently she would resist its being opened, the hinge became loosened, and the door was pulled down upon her. She held on to the door with such tenacity that I pulled it into bits in my efforts to remove it from her grasp. It was removed Dec. 30, '85, and on the following night she built another as neatly as the first. The hinge to this became loosened and the door moved down about 5^{m.m.} from the mouth of the tube. Here she strengthened the hinge by spinning a broadpiece of silk, the width of the hinge, from the door down on to the wall of the tube. Several times in endeavoring to open the door I tore pieces from its edge and in every instance the spider repaired it. Finally, when I wished to remove her from the tube I was obliged to push up on the cork bottom, and in this way crowd her out through the door. After this was done it was with some difficulty that she freed her posterior feet from the silk bag which she had constructed at the bottom, so firmly did she hold on.

I have this yet to add. In a note I have mentioned the wandering of the spider about in a jar of freshly prepared earth, Jan. 16. For three days she has been restless, and though several attempts have been made to dig a tube she has failed. I came to the conclusion that the soil was not such as she could work easily or satisfactorily. Wishing to have soil which would make a more desirable tube than the loose soil in which I saw the first nest made, I used a large proportion of fine plastering sand mixed with black earth. This was wetted, and pieces of moss strewn over the surface. She tried several times to take up pellets of the earth, but seemed to be disgusted with its crumbling. She then tried to bore a hole by pushing down with her mandibles while turning her body around. She evidently wished to hide her head from the light, for after making a hole 2^{cm} deep she remained with her head at the bottom. To-day, Jan. 14, '86, the soil in the woods having thawed sufficiently I prepared a jar of moist, ferruginous clay, very much like that of which

the nest is constructed that came from Pittsboro. Upon this I put a fine mat of fresh moss, covering the earth except a spot at one side $2\frac{1}{2}$ " in diameter. In this I placed the spider at noon. I then covered it from the light. As I returned to my room after dinner she was resting in a hole 3" deep which she had excavated, and small pellets of earth were placed against the moss at the mouth of the hole. She would not work during the day unless I covered the jar from the light. During the evening, by lamp light, I had the pleasure of seeing her make another door. It required about $1\frac{1}{2}$ hours. Only one piece of moss was used and that I let drop into the hole while she was at work. This seemed very strange for the tube was the only place not covered with moss, and to save her the trouble of cutting the moss I had strewn loosened particles about the hole. In this case all of the earth used in the construction of the door was taken from the bottom of the hole. The door being made almost entirely with the clay was very conspicuous in comparison with the surrounding moss; though the door fitted very neatly, the tube being built up to a level with the top of the moss. This time instead of making the hinge against the side of the jar, it was made on the opposite side of the tube.

I was unable to understand how the resistance to opening the door was offered, if the spider fastened its fangs and *all* of its claws into the under surface of the door, as Mr. Moggridge states.¹ A reference to Plate XXIV. Figs. 3 and 4, will show the results I reached in the experiment when the spider was induced to make a trap-door to the mouth of a glass test tube. The portion of the tube from *b* to *c* was not lined with silk. The spider, evidently not admiring the cork at *d* for a bottom to her nest, carried in pellets of earth and bits of moss as shown at *g*. She then spun a short bag of silk, *f*, which was attached by the mouth to the walls of the tube at *c*, and rested on the piece of cork. The mouth of the test tube was lined with silk from the edge for about 5^{m.m.} to 7^{m.m.}. The ends of the silk lining at *b*, and the silk bag at *c*, were for some distance transparent so that I was enabled to see the spider fairly well. As can be seen in fig. 14, the spider clings to the bag of silk at the bottom (or walls of the tube) with the claws of her two posterior pair of legs, and to the under surface of the door with her fangs and

¹Harvesting Ants and Trap Door Spiders, pp. 95 and 96.

the claws of her anterior pair of legs. By partially lifting the door I was enabled to see the hold upon the door, and when I pushed the spider out of the tube, as before stated, I found her feet entangled in the bag of silk. The manner in which this spider holds down the nest is precisely the same as that described by Emerton¹ in the case of *Cteniza Californica*, except that he states the "3rd and 4th pairs of legs are pressed out against the walls of the tube."

The nest of this spider belongs to the simple, unbranched type with shallow cork door. The door belonging to the nest in which the spider was caught (Plate XXIV. Fig. 1,) measures 3 to 4^{m.m.} in thickness; the edge is beveled and fits neatly in the mouth of the tube. The door measures 25^{m.m.} across near the hinge; the tube 60^{m.m.} in length. The walls are badly collapsed and the lower edge ragged and open. It will be remembered that the spider was found in the earth below the tube when the nest was taken up in November. The first nest which the spider made under my observation was open at the bottom, and when I attempted to take her out, finding she could not hold down the door she attempted to bury herself in the soil at the bottom of the tube. The question naturally arises, Is this not left open as a last means of escape from enemies? I am inclined to think it is, in some cases at least with this species, as this is the only resort for safety after the door is open. Further observation is needed on this point. The trap-door of this nest is so hung that it tends to close itself. In Fig. 2, Plate XXIV. at *a* are patches of silk that are drawn on the stretch when the door is open. When all resistance is removed these tend to close the door.

The subject of the food of trap-door spiders is an interesting one, and much is yet to be learned of their habits in this respect. While I had the spider out of her tube I offered her several house flies, holding them by one wing, with the forceps, near her head. The struggles of the fly attracted her attention. With a quick sweep of the palpi and anterior pair of legs she would clutch the fly and place it between her powerful mandibles, crushing it immediately. She held some of these about one minute, but I very much doubt her having derived any nourishment from them. One of the smaller species of the flies belonging to the genus *Tabanus* was offered her. It seemed only to frighten her as she could

¹Structure and Habits of Spiders, p. 45.

not be made to touch it even by being angered, but would turn and run away as if in great fear. After returning the spider to her nest, Dec. 8, I placed in the jar two ants and a small carabid beetle. The ants hid themselves in the earth. Dec. 14th, the beetle was still unharmed and I concluded the spider did not come out for food. I then lifted the trap-door and placed the beetle inside. Dec. 16, I found the broken hard parts of the beetle strewn about just outside the nest. It had been killed, the soft parts eaten by the spider, and the parts of the skeleton ejected from the nest. Jan. 17, '86, I placed a half dozen large yellow ants in the jar.¹ As they attacked her she would catch and crush them but I did not see that she ate any of them.

Jan. 2, '86, which was like a summer day at Chapel Hill, I went into the woods for the purpose of collecting some moss. While tearing up a large patch of this, at the foot of a tree, I discovered a hole which I thought to be the nest of a trap-door spider. I dug down into the tube and found at the bottom a spider belonging to this family. In the afternoon I found several nests and one more female spider. Under some stones I found a male. I placed them in jars of earth containing moss. One of the females escaped; the other built a nest and made a slanting double door, which might be compared to an outside cellar door. Each door is made of moss cemented with silk and hung by a semicircular hinge. These the spider will open and shut at pleasure, sometimes fastening them together with a thread of silk. In both of the nests in which I found these spiders, there were the remains of ants. I had intended to illustrate and describe farther the nests and habits of these found by myself at Chapel Hill, as they are lively creatures and seem to offer interesting objects for study as to habit, food and architecture. But as this article is already long, and I wish to make further collections and study their habits more closely in captivity I will reserve the subject for a future time.

¹The spider was not in her nest.

EXPLANATION OF PLATES.

PLATE XXIII.

- Fig. 1. Spider, natural size; dorsal view.
 " 2. Spider, natural size; ventral view.
 " 3. Spider, natural size; side view.
 " 4. Spider in the act of unloading a pellet of earth while excavating the tube. *a*, pellet of earth.
 " 5. Spider applying viscid liquid to the freshly placed pellet of earth. *a*, spinneret.
 " 6. Spider applying viscid liquid to the edge of the partially constructed door. *a*, spinnerets. *b*, door. *c*, pieces of moss.
 " 7. Spider in the act of fitting to edge of the door a pellet of earth, *a*.
 " 8. Trap-door showing eight concentric rings which represent the successive additions to the edge of the door corresponding to the enlargement of the tube. *a*, hinge

PLATE XXIV.

- Fig. 1. Natural size of nest in which the spider was caught.
 " 2. Trap-door open. *a*, bands of silk which tend to close the open door. *b*, claw and fang marks of spider made while holding down the door.
 " 3. Nest made in glass test tube. *a*, hinge. *f*, bag of silk. *d*, cork bottom. *g*, pieces of moss and earth.
 " 4. Spider in act of holding down the door, while in the nest. All natural size.

A FAMILY OF YOUNG TRAP-DOOR SPIDERS.*

(*Pachylomerus*, 4—*spinosus*.)

Two questions were asked by Mr. Moggridge about the habits of young trap-door spiders. For the answer to these he was unable to make any observations, so far as the record shows. The questions are; 1st, do young trap-door spiders make nests like those of the parent without being shown?

*This paper has been previously published in the *Entomologica Americana*, Vol II, Aug. 1886. (3)

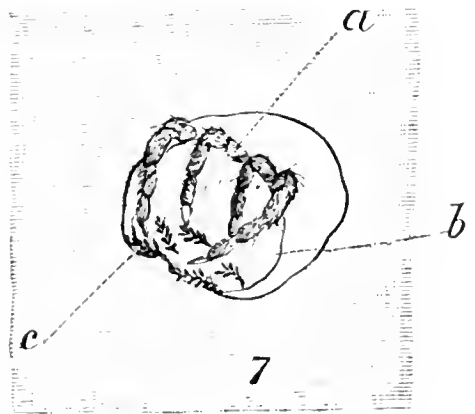
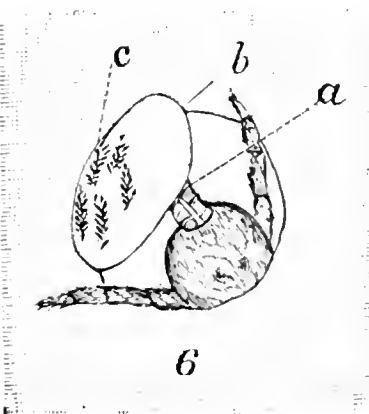
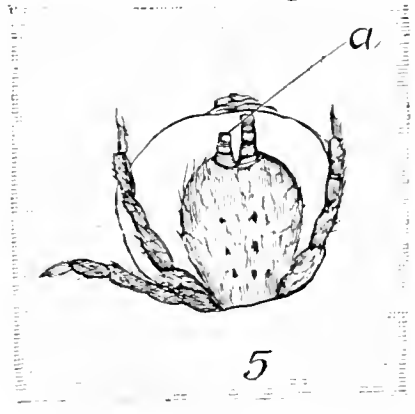
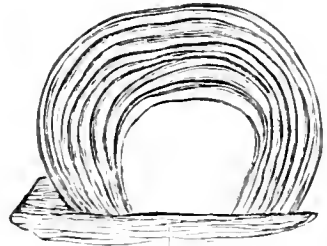
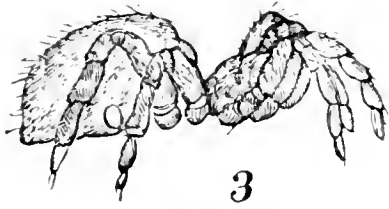
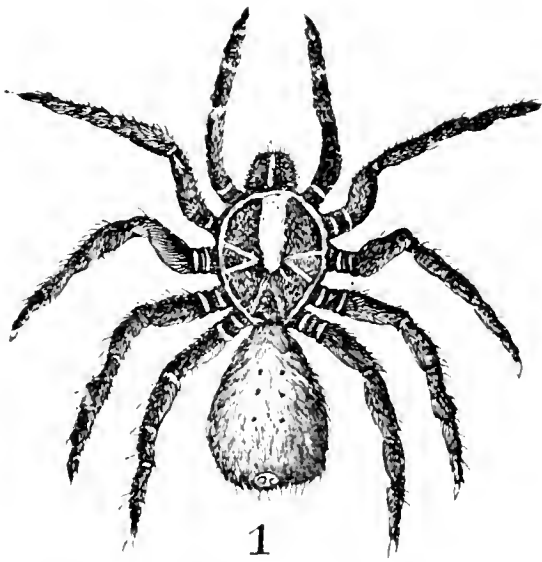

G.F. Atkinson del.

A new Trap door Spider.

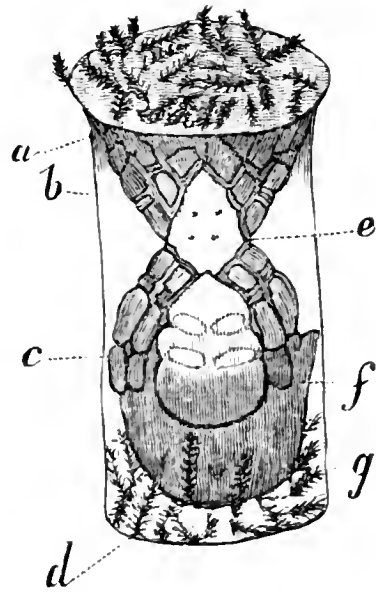
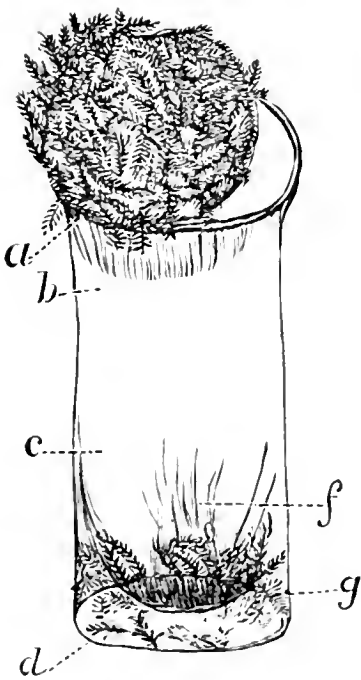
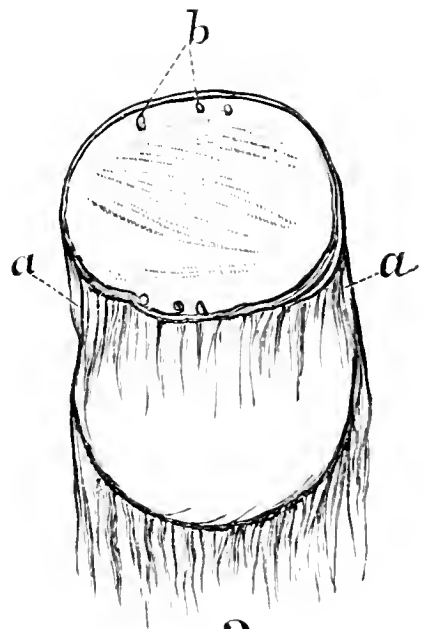

3

4

G.F. Atkinson. del.

A new Trap-door Spider.

2nd, do the males of trap-door spiders make a nest with a trap-door when very young? To the first question we would almost unhesitatingly reply in the affirmative, without direct observation. In regard to the second, it is well known by those who have given much attention to the habits of trap-door spiders, that the mature males, at least, do not build trap-door nests, but seek a hiding place under stones, logs, etc.

There is also another question as to the constancy with which species follow a *uniform type* in the construction of their nests. Some naturalists make the different kinds of nests a partial basis for classification, and others are looking for differential characters manifested in the variations of the trap-door; whether the door is horizontal; the hinge lower or higher than the distal part of the door sloping one side, etc.

The object of this paper is to present the variations produced by a family of 28 young trap-door spiders, in the building of their nests, which I have carefully observed and noted. I trust also to show that, from the labors of these little creatures, and of several mature ones, which I have had in captivity, a great deal of light is thrown on the questions stated above.

The family was captured by D. E. Woodly, student at Chapel Hill, N. C., March 17, 1886. The mother had either deserted her children, or had met with her death. The tube was doorless and near a decaying stump. The 28 children were living peacefully together in the silken cocoon which had contained the eggs at the bottom of the tube. After keeping them together in a small vial for one day, I prepared a bottle of earth for each one. The bottles measure $1\frac{1}{2}$ inches in diameter by three inches deep. In each about $1\frac{1}{2}$ inches in depth of earth was placed. The earth was moist, loose, but smoothed over and gently packed to furnish a smooth surface for operations.

The following table shows the time of beginning and completion of the work of each. In column 4 is given the time when the work began which was carried to completion. Some began work earlier than here indicated but abandoned it.

| 1 | 2 | 3 | 4 | 5 | 6 |
|-----|-------------------|-------------------------|--------------------------|-----------------------------------|-------------------------------|
| No. | Date Mar. '86. | Time plac- ed in bot | Time when work began. | Time when trap- door was begun | Time trap- door was comp'd |
| 1 | 18 | 5 p m | Unobserved. | Unobserved. | Unobserved |
| 2 | 18 | 5 p m | " | " | " |
| 3 | 18 | 5 p m | " | " | " |
| 4 | 18 | 5 p m | Mar 19, 3.30 a m | 5 a m | 5.15 a m* |
| 5 | 18 | 5 p m | " 19, 12.30 a m | 1 a m | 2 a m |
| 6 | 18 | 10.30 p m | " 19, 2.30 a m | 4.20 a m | 5 a m |
| 7 | 18 | 10.30 p m | " 18, 11.15 a m | Mar 19, 12.30 a m | 1 a m |
| 8 | 18 | 10.30 p m | 11.30 p m | " 19, 3.55 a m | 4.20 a m* |
| 9 | 18 | 10.30 p m | Mar 19, 12.30 a m | " 19, 12.30 a m | 2.30 a m |
| 10 | 18 | 10.30 p m | " 19, 2 a m | 3.20 a m | 4 a m |
| 11 | 19 | 4.10 p m | " 19, 7 a m | 9 a m | 10 a m |
| 12 | 19 | 4.10 p m | " 19, 4.15 a m | 5.55 p m | 7.30 p m |
| 13 | 19 | 4.10 p m | " 20, 11 a m | Unobserved. | 2.30 p m |
| 14 | 19 | 4.10 p m | " 19, 4.30 p m | 5.50 p m | 6.30 p m |
| 15 | 19 | 4.10 p m | " 20, 10 a m | 1 p m | 2.30 p m |
| 16 | 19 | 4.30 p m | " 19, 5.18 p m | Unobserved | Unobserved |
| 17 | 19 | 4.30 p m | 5.15 p m | 6.20 p m | " |
| 18 | 19 | 4.30 p m | 4.45 p m | Unobserved | " |
| 19 | 19 | 4.30 p m | 5.10 p m | 5.50 p m | 6.30 p m |
| 20 | 19 | 6.30 p m | 7.00 p m | 9.15 p m | Unobserved |
| 21 | 19 | 6.30 p m | Unobserved. | Unobserved. | " |
| 22 | 19 | 6.30 p m | " | " | " |
| 23 | 19 | 9 p m | 9.20 p m | " | " |
| 24 | 19 | 9 p m | 9.50 p m | " | " |
| 25 | 19 | 9 p m | 9.25 p m | " | " |
| 26 | 19 | 9 p m | Unobserved. | " | " |
| 27 | 19 | 9 p m | Mar 20, 4 p m | Not noted. | Not noted. |
| 28 | 19 | 9 p m | " 21, 10 p m | 1 p m | 5 p m |
| | | 9 p m | " 20, 10 p m | 11 a m | 11.30 a m |

* Nest was destroyed and another built.

Variations from the normal type. By the normal type is meant that which seems to be the simplest, most nearly perfect, plan of construction, is followed by a majority of those observed, and seems to indicate a *natural instinct*, a more potent influence of inherited habit in some, while in others the instinct seems to be latent at first and gradually unfolds with the dawning of consciousness! According to the normal type, the spider takes up pellets of earth with its mandibles, and turning around, places them upon the soil by the side of the tube, which is being dug; or carries or throws them to a short distance. Occasionally with its spinnerets it applies viscid liquid to the pellets and edge of the tube, much as an artificer would alternately place cement and bricks in the construction of a column. The trap-door is built in the same manner, by beginning, at one side of the

edge of the hole, a horizontal wall to which particles are cemented and pressed in shape to make a flat, circular, lid to the tube.*

By a study of Plate IV we shall see some of the variations from the normal type. Fig. 1, *a*, represents one of the spiders, natural size, *b*, section of a nest built after the normal type, door represented open, also natural size. All of the other figures, except 15 and 16, are magnified. In fig. 2, one side of tube, *a*, is extended above ground and carried over the tube. The door, represented open, is hinged at *b*; when closed it slopes downwards from the hinge attachment, fig. 3. This was the work of No. 3. The arched wall from *a*, was pressed in shape in the same way that the trap door is, so that when the spider began it at *a*, I thought it had begun the trap door, and made this entry in my notes: "At 4.30 door begun; two-thirds of the edge used for attachment of the hinge, making an awkward door." When the hinge was made at *b*, it was easy to see the arching of the wall was intentional. In fig. 10, the tube is curved above ground in a similar way, but the hinge is at one of the sloping sides, making a door that swings to the right and left instead of up and down. This was made by No. 25. Figures 4, 5, 6 and 7 represent the work of No. 15. A trench was dug, using the excavated earth for a wall on each side; the walls were then united by an arch over the middle, one end closed and a trap-door made at the other end. Fig. 8, represents the nest of No. 22, built in the same way as that of No. 15, except that at *a*, the hole was not entirely closed. No. 13 built what is shown in fig. 9. A trench with a wall each side was first built; in the middle of the trench was dug the tube and the door hinged at the base of one wall at *a*, with the distal part of the door elevated at *b*. Fig. 11, shows the work of No. 24; a trench was dug by the side of the glass with a wall on one side at *a*; on the other side earth was carried upon the side of the glass and attached in small lumps at *b*; *c*, represents the nest, a small tower against the glass. Fig. 12, was made by No. 26. This is interesting as being the only one showing the concentric "lines of growth" usually noticed in the doors of nests that have been used for a year or so. No. 14, first dug a shallow hole as represented at *b*, fig. 13; abandoning this it dug

*For description and illustration of the building of a nest and trap-door by *P. Caribivorus*, see Amer Nat for July 1886.

another at *c*; it then removed the earth at *d*, making a trench; next it began the tube at *c*, but soon abandoned it, began again at *b*, restored *d*, and completed the nest in the normal way. The following table shows the varying positions of the door when closed.

Horizontal: Nos. 1, 2, 4, 5, 6, 9, 10, 11, 12, 14, 16, 18, 19, 20, 21, 23, 27, 28.

Sloping downward from hinge attachment: Nos. 3, 7, 8, 15, 17, 22, 24, 26.

Rising from hinge attachment: No. 13.

Sloping door with hinge at one side: No. 25.

Table showing the kinds of nests.

Curved tube: Nos. 3, 8, 25.

Straight tube: Nos. 1, 2, 4, 5, 6, 9, 10, 11, 12, 13, 14, 16, 18, 19, 20, 21, 23, 24, 26, 27, 28.

Trench with arched walls: Nos. 7, 15, 17, 22.

Nests of mature spiders, of this genus made in captivity present some of the variations mentioned above, as also some of the nests found in a state of nature.

One of the most interesting things which came under my observation during the work of these spiders was the varying potency of instinct manifested in the aptness with which each performed the task of building its home. This will be best illustrated by giving a few of the more striking examples recorded in my notes. No. 6, was placed in the bottle at 10.30 p. m. and began digging the tube in the normal way at 11.15 p. m. It worked rapidly, sometimes aking up and unloading a pellet of earth in 10 seconds. Indeed it worked with as much ease, accuracy, and apparent thoughtfulness, as the mature one which I have described in the previous paper. Sometimes with its palpi it would flirt the pellet across to the opposite side of the bottle. It began making the trap-door at 12.30 a. m. and completed it at 1 a. m.; one hour and forty minuts from the time it began work, and two hours and thirty minutes from the time it was placed in the bottle.* During the operation every movement seemed to facilitate the work. No. 19, was placed in the bottle at 6.30 p. m.: my notes read as follows:—"Began digging tube in normal way at 7.50. Does not seem to be satisfied with work, and begins in another place. This is done several times: 9.15 began making trap-door," etc. No.

*One completed the work in one hour and 20 minutes; and another 1 hour and 30 minutes.

26 was placed in bottle at 9 p. m., Mar. 19th. At 1 p. m., Mar. 20th, it began digging and soon abandoned this place for another. This it repeated as many as a dozen times, sometimes returning to the work and tearing away at the soil as if in a frenzy, and impelled by some irresistible power. Then suddenly leaving the spot it would wander and endeavor to climb the side of the glass; when it would as suddenly be seized with an irresistible inclination to tear away at the earth without any seeming purpose. Occasionally it seemed to work with more deliberation, as if it were gradually becoming conscious of a latent instinctive power! At 4 p. m. it continued work in one place until the nest was completed, but the door, which is represented in fig. 13, was barely hung together and was loosely hinged by three strands. A few days later I tore down this nest, when the spider went to work in the normal way and built a perfect nest. Upon this point alone it would be interesting to follow carefully the notes I have taken on all, but I fear it would make the article too long, so I will conclude this subject with reference to a few others. One without digging in the normal way pressed the dirt aside; buried itself, and then spun a bag of silk surrounding it. When removed from this it went to work in the normal way. Several others acted very much like this one, and No. 26.

These variations could not be attributed to a difference in the nature of the soil as in the case of variations noticed among adult spiders, when the soil at times was of a different character. Care was taken that the soil should be of the same compactness and moisture for each. In some cases a hard lump caused the spider to remove to another place, and in one or two instances the spiders waited so long before beginning work that the soil was too dry; pouring in water packed the earth too hard and it was necessary to loosen it before the spider could take up a pellet. With close watching and due allowance for conditions just mentioned there seems to be great variableness in the attitude which different young individuals at first show in the construction of their nest. In some cases the consciousness, if fit might so be called, of instinctive power flashes upon them when they first are made to shift for themselves; while with others there seems to be a greater or less development or dawning of the same consciousness.

Mr. Moggridge also asks at which end of the tube the spider begins to spin the silken lining? This species, so far

as I have observed, (I have watched over thirty individuals,) always begins at the upper end. I had several opportunities of witnessing this among the young ones, and one mature one,* when the spinning of the lining was done very beautifully. In fig. 14 a spider is represented in the act of spinning the silken lining at the upper part of the tube. When the viscid fluid coming from the spinnerets cools before it is applied to an object it forms a broad band or ribbon as it might be called; by elevating and depressing the body perpendicularly as shown in fig. 14, and touching the spinnerets here and there to the wall of the tube this ribbon of silk is fastened. By moving around the tube at the same time the lining is made complete for the perpendicular distance covered by the spider in its movements. Some times instead of elevating and depressing in the manner just described the spider will move around the tube fastening the ribbon in circles.

Figs. 15 and 16 represent a novel way of excavating a hole which I witnessed in the case of a mature spider. With its legs as supporters on each side of the tube it would elevate its abdomen in the air and hook its mandibles in the earth at the bottom of the hole; then revolving through a quadrant about the axis at *a*, fig. 15, it would bring the earth to the surface and push it off with its palpi, as shown in fig. 16.

From this study we may conclude the young of trap-door spiders build their nests instinctively; that males as well as females build trap-door nests before the sexual character and habits are well developed, which in the case of the males make a somewhat wandering habit necessary in order to find the females; that young and old vary in making their nests from the normal type, so that the position or relative sloping of the door or tube could not be of any value in the classification; that this species does not use its legs to aid in spinning the lining to its tube, and that they spin the lining at the upper end of the tube first; and lastly that they vary in the degree of skill manifested as artificers and the maturity of instinctive power.†

EXPLANATION OF PLATE.

Fig. 1. *a*, Young trap-door spider, natural size *b*, section of nest with open door, built in normal way, also natural size. Figs. 2 and 3 curved

**P. turris*

†All of the observations made use of in the preparation of this article were made on three species. Descriptions of the new species collected, their nests, and food habits, I hope to have published in a subsequent article

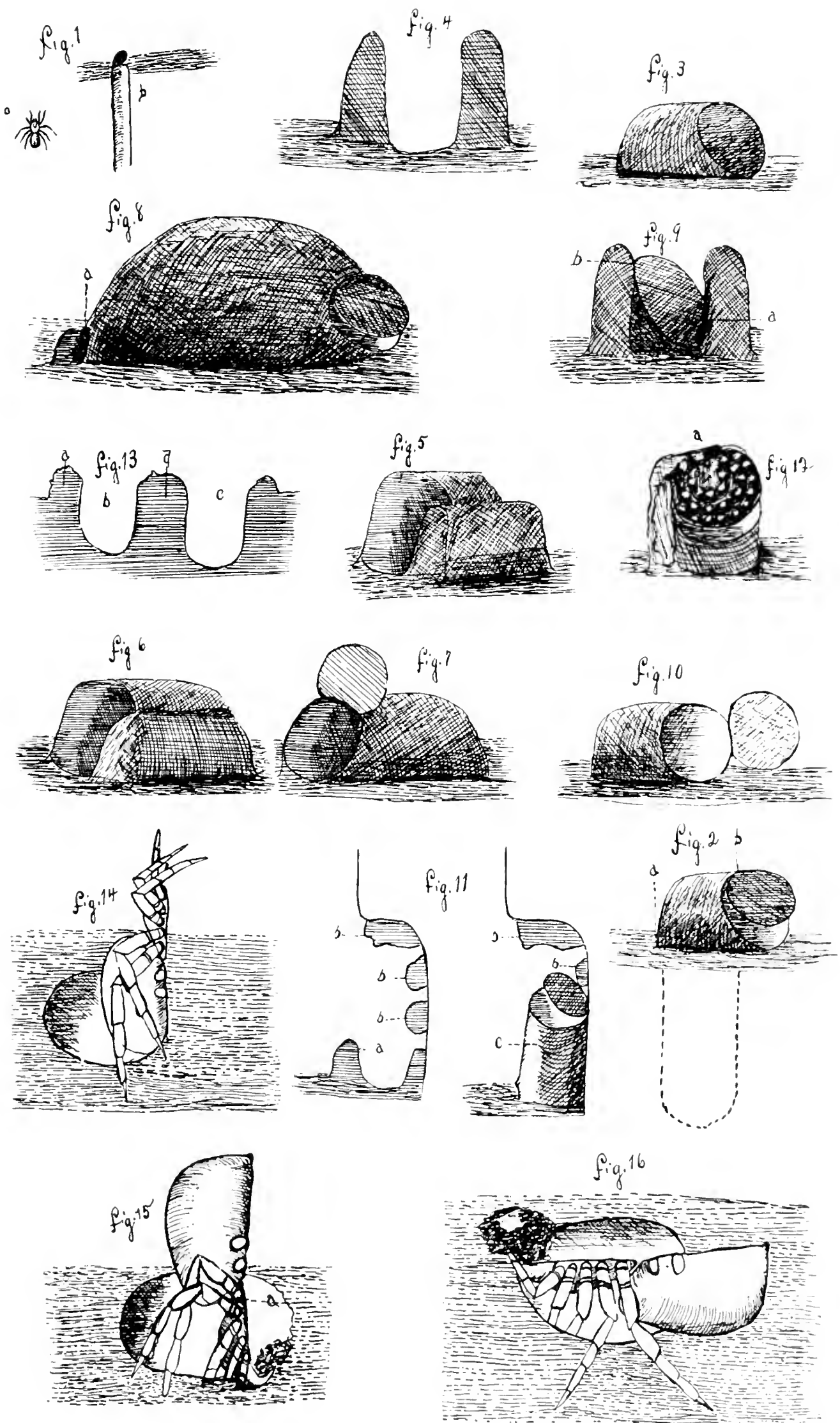

Geo F. Atkinson; from nature.



tube with slanting door. Fig. 4, trench with wall each side seen from one end. Fig. 5, arch connecting walls. Fig. 6, same, closed at one end. Fig. 7, same, with trap-door built at the other end. Fig. 8, another built on same plan, but the first opening not quite closed, a loose flap at *a*. Fig. 9, tube dug between two walls, hinge at *a*, distal part of door at *b*. Fig. 10, curved tube with door hung so as to swing to the right and left. Fig. 11, section of bottle showing work of spider: *a*, wall, *b*, pellets of earth carried up and stuck to the glass, *c*, nest, a tower against the side of the bottle. Fig. 12, nest showing concentric "lines of growth," in the trap-door. Fig. 13, *b*, first hole dug by spider, *c*, second one, *d*, wall between which was r. moved making of the excavation a trench, subsequently *d*, was rest-red and nest built in normal way at *b*. Fig. 14, spiders represented in act of spinning silken lining to the upper end of the tube. Figs. 15 and 16 *P. turris* adult spider taking a novel method of excavating a hole

NOTE.—The doors of all the young trap-door spiders' nests are very thin, from 2 to 3 ^{mm}. in thickness. One spider worked so rapidly that it would sometimes pick up and unload a pellet of earth in 8 seconds. As a rule they required a much longer time than this.

DESCRIPTIONS OF SOME NEW TRAP-DOOR SPIDERS; THEIR NESTS AND FOOD HABITS.

A few months after writing the previous article, "A new trap-door spider," I found a specimen which differed so markedly in color from the one, the subject of that article, and agreed so closely with the one described by Hentz as *Mygale carolinensis*,¹ now *Pachylomerus carolinensis*,² Hentz, that before having an opportunity to study them carefully I concluded the only difference was in color. Just after the article "A family of young trap-door spiders," was ready, I discovered that the two forms were different species; that the one called "A new trap-door spider," and the young spiders whose work has just been described in the Ento. Am. were both new species: the former I have called *Pachylomerus carabivorus*, and the latter *Pachylomerus 4-spinosus*.

The nests of *P. carabivorus*, *P. 4-spinosus*, have already

¹The Spiders of the United States, by Nicholas Marcellus Hentz M. D., Boston Journal, IV; p. 56, pl. VII, fig. 3.

²Beitrag zur Kenniniss der Territelariae, Ausserer, p. 147.

been described in the articles referred to. One thing, however, in regard to *P. carabivorus* is worth adding. The last trap-door made by this species as described on p. 20 was in sharp contrast, being made almost entirely of clay, with the surrounding moss. In a few days the spider made an examination of its work and found it had made a mistake in not placing moss in the door. It remedied this as well as possible by cementing moss to the edge of the door and pressing the ends down so that about half of the door was covered with moss!

Nest of Pachylomerus turris. March 5, '86, on turning over an old log, a sudden movement of an object downward attracted my attention, I looked and discovered a silken tube, with particles of earth and leaf mould attached extending above ground. On one side the silk was so extremely thin as to afford a "window" to the spider's house! It was through this that I had discovered the movement which attracted my attention. Nearly the entire remaining portion of the tube was covered with earth and leaf-mould, and here the silk was thinner than in other portions, yet intact. It seems almost incredible, yet from the wonderful intelligence manifested by these spiders, I was led to think this "window" had been purposely made: that the spider would sit by it and watch for beetles crawling about under the log, and seeing one would rush out through the door, seize its prey and return to its tower! It seems more reasonable when we consider that *Nidivalvata marxi* (see food habits of this species,) will nightly open its doors, remain out of sight, watch for passing insects, and rush out and seize them. The tube was about 8cm. in length, and there was only a very shallow excavation in the clay soil. The door is of the "wafer type," and was fastened down by silk, probably in the fall when the spider prepared for hibernating.¹

In the evening I placed the spider in a bottle of earth. During the night it burrowed into the soil and made a rude door, which appeared more like a flap hung from one side of the mouth of the tube. On the evening of Mar. 7, I re-

¹Mr Moggridge says in *Harvest Ants and Trap-door Spiders*, Supplement, p. 236: "I have on very few occasions, found the doors of a wafer or cork nest, spun up during the winter at Mentone, and on digging have discovered the spider alive, though partially torpid, inside; but this I think is quite an exceptional event. I should like to know however, whether this becomes the rule in the case of the nests of those

moved a portion of the soil and placed in a portion of clay intermixed with loam, scattering over this a few bits of moss. I did not see the spider make the burrow, but next day saw it make two-thirds of a door, when I put an end to operations on that nest. The door was made practically in the same manner as that by *P. carabivorus*, but was a wafer door.

From the appearance of the tube and the soil about it in both of the nests made in captivity, I felt sure this spider did not dig the hole in the *normal way*. Accordingly, Mar. 8, I prepared a jar of wet clay. Up to 11 p. m. the spider had not begun work, but in the morning the work had not progressed too far for me to observe it. The spider begins the burrow in a manner similar to that practiced by *Nidivalvata Marxi* by pressing the earth aside from a central point with its anterior legs, using also its mandibles, but it is much slower in its movements than *N. marxi*. *Pachylomerus turris* is the spider represented in fig. 15 and 16 of Plate III. excavating in a "novel way." In making the trap door, sometimes when in this position it would cement the particle to the door by pressing on top of the door with its posterior legs, against the ventral surface of the cephalothorax. When the hole was about 3cm. deep it would occasionally take earth out in the normal way.

It will be seen that the habit of this spider is not wholly nocturnal in building its nest. During the month of July while I was at Ithaca, N. Y., I had a specimen of *P. carabivorus* make a nest for Prof. Comstock. This was made en-

trap-door spiders which inhabit climates less favored than that of Mentone." He also speaks of a *Lycossa* that is said to close her nest in Cannes in winter. Latreille, in Mem Soc. Hist. Nat. Paris, (an VII, de la Republique) p. 124, says "L'araignee tarentule ferme aussi son habitation, mais cet opercule n'est pas mobile, et n'est construit que pour l'hiver." I have on several occasions found that *P. carabivorus*, after eating one or two beetles, fastens down the lid with silk. *Nidivalvata Marxi*, I have found fastens the door at times (See Amer. Nat. Vol. XX, p. 592.)

O. P. Cambridge, in Annals of Nat. Hist 1878, 5th series, Vol. I, p. 107, says that in all cases that came under his notice the upper extremity of the nest of *Atypus piceus* was without any perceptible orifice. He finally came to the conclusion that the spider gnawed its way out and then closed it with fresh thread again. These examples seem to indicate that spiders will very frequently at least fasten the doors to their nests during a period of rest, when inactive and more liable to be injured, when having had sufficient food, and perhaps sometimes at regular periods when not engaged in watching for food. It seems reasonable to suppose that in climates where the spiders are in a torpid state they would fasten their doors during this period.

tirely during the day. By reference to the young trap-door spiders it will be seen that *P. 4-spinosus* works just about as well in day as at night.

Nest of Nidivalvata marxii. The first one of this species which I found was taken Jan. 2, 1886, and which I have formerly mentioned as making in captivity a "folding door." In tearing up some moss I observed a tube in the bottom of which was the spider. Whatever there was at the upper end of the tube was destroyed in removing the moss, so that I have not had an opportunity to observe the door to the nest where the spider makes its nest in a patch of moss. I have found several nests of this species by gathering moss. In all there were what appeared to be branches just above the surface of the ground at the base of the moss. These I regard as avenues in which the spider would search, or lie in wait, for ants.

In captivity this spider made a very interesting nest with folding doors (See figs. 17 and 18 Plate IV) and I believe it is with some such arrangement that it closes its tube in a state of nature, for the spider makes use of it in catching its prey, as will be described in the food habits of this species. This kind of a door, I believe, has never before been seen or described, and adds one to the different types of nests which Mr. Moggridge has described and named.* The right name for this type should be "double door," but as Mr. Moggridge has used that name for a nest which has two doors, one at the upper end of the tube and another some distance below at the opening of a branch in the main tube, it cannot be applied to this one. So I have called this new type the *folding door nest*, from the manner in which the door opens and shuts.

This species begins the excavation of its tube by parting the earth from a central point with its anterior legs and palpi turning around at the same time so as to push the earth on all sides. It works with exceeding rapidity, and in this respect is in strong contrast with the members of the genus *Pachylomerus*, though the young ones of that genus work more rapidly than the older ones. When beginning the nest in a patch of moss the spider will dive down in the moss and begin turning rapidly in all directions, at the same time spinning threads to fasten together the pieces of

* Harvesting Ants and Trap-Door Spiders; and Supplement.

moss around and over it. I have watched four different ones make the nest, two beginning in moss which I had placed over the earth, and two beginning in soil. Two of these I had make a nest several times, and thus far every one has first entirely closed the entrance to the tube by building a sort of dome above it. Later, in one case a week, cutting through this and making the folding door.¹ Usually while at work near the surface of the earth it will burrow out in different directions and elevate the surface of the earth. This I think is partly for the purpose of providing a place to put the earth which it excavates from the lower portion of the tube as I have seen these filled up; and in one specimen, after the tube was about 2 cm. deep I observed the same habit of digging and cementing to the edge of the tube, as observed in the case of *Pachylomenus carabiorus* and *4-spinosus*. This individual made the dome by carrying up three sides regularly until it had completely covered the entrance. Usually in making the dome earth is placed on and about the edge of the tube, occasionally applying viscid liquid and spinning threads over it. Then the spider would, with its anterior legs and palpi pull the edge over the tube. This operation would be repeated until the dome was complete.² When moss is convenient the door is made almost entirely of moss and silk; each door is a surface of a half circle, is hung by a semicircular hinge, and the two meet, when closed, in a straight line over the middle of the hole, as shown in fig. 18, Plate IV. Every night (I ob-

¹ NOTE.—In the Encyclopedia Britannica, 9th edition, 1875, Vol. II, p. 291, O. P. Cambridge says: "The present writer was once told by a gentleman who had to mealy resided in the West Indies that trap-door spiders invariably made the tube and lid of one continuous, solid, homogeneous piece, and then cut out the lid with the falcers. This account, especially as coming from a non-Naturalist seems improbable, a spider's falcers being in no way fitted apparently for such an operation." Where the silk lining was thin, it would be a very easy matter for a spider to cut through, and then repair the roughness by cementing on particles. It is probably an exaggeration to say that they "invariably" construct them in that manner, but I should not be surprised if some species made the trap-door in the manner described by this non-naturalist."

²I have never seen this spider press the lid on the end of its mandibles as does *P. carabiorus*. I think this shows the adaptation of the special armature of the mandible of *P. carabiorus*, and related forms, for fastening the earth to the lid. *P. carabiorus* usually makes no thread in applying the viscid liquid to the door while adding particles, but puts it on as a cement. The large point of the mandibles, which is covered with short strong spines serves admirably to punch the earth irregularly into the portion of the door already made, and causing it to adhere firmly.

served one in my room for three months) the spider would throw open its doors as shown in fig. 17, Plate IV and in the morning close them. If I opened the door during the day time the spider would invariably come up and close it, but never immediately, and never did it offer to catch the door and resist its opening. When members of this genus build their nest under stones, as they sometimes do, if the stone is elevated from the earth in one place the spider builds the tube above ground to the under surface of the stone, and here makes some sort of door, I have never been able to see just what, but probably very much like the ones made in captivity. A longitudinal section of one of these nests which I found under a stone is shown in fig. 11, Plate IV, the surface of the ground at *a* and the mouth of the tube at *b*. On turning over the stone I saw what I thought was the cocoon of a moth, from which the insect had escaped at the upper end. I picked it up, and discovered the tube which I found about 12 inches deep, with the spider¹ at the bottom. This nest, perhaps inappropriately, I have called the *hall door nest*, because of the enlargement just within the entrance. This I consider would be of advantage to the spider in managing the door while catching an ant. The portion above ground was made of loam and leaf mold cemented with viscid liquid and lined on the inside with silk. So far as I have observed, the members of this genus line only that portion of the nest with silk which is liable to cave in near the upper portion of the tube.²

Nest of Myrmekiaphila foliata.

The nest of this species is not constant in type, and shows wider variation in different individuals than any of those thus far described; but when taken in connection with the food habit of the species there does not seem to be a very great departure from a common type.

The first individual was collected March 13, '86 by myself. In collecting specimens of ants and their root feeding "cows" (Aphides) which they were protecting through the winter, I found a trap-door on turning over a stone. The tube I traced down about 14 inches, when I came upon and struck the spider off at one side. In doing so I broke off a

¹ *Nidivalvata angustata.*

² I have observed the same thing with *Myrmekiaphila foliata.*

leg and palpus so that the spider died the next day. At the time I thought the spider must have underground galleries in which it hunted for ants similar to the galleries in the moss of the nest of *Nidivalvata marxii*. But since finding the nests of other individuals I think there must have been a branch from the main tube with a trap door, and the soil being so full of rocks I failed to find it.

The second individual I collected on the morning of Apr. 6, '86, while digging into a side hill with a southern exposure for white ants (*Termes flavipes*). Discovering a tube I traced it until I found at one side a trap door opening into a short branch. In this I found a fine specimen of trap-door spider. The nest I concluded belonged to the type called by Mr. Moggridge, "Double door branched nest," but differs from that in having a cork door instead of a wafer door. I did not see the door at the end of the main tube, if there was one, as the soil was very loose and rocky, and every trace would have been destroyed before finding the main tube.

The third individual was collected in the afternoon of the same day, by one of the students, D. E. Woodley. The tube ran under a stone, a trap-door was at the upper end, but the branch and second door was not seen. Mr. Woodley said, however, that it might have escaped his notice as the tube was not traced out very clearly.

The fourth individual I collected Apr. 6. On turning over a stone I saw what is represented in fig. 16, Plate IV, except that the trap door was closed, and the spider was in the tube a short distance below it. The space above the trap door is a portion of an ant's nest, *b* is the entrance from the surface of the earth; *a, a*, is a broad hall-way leading off into galleries on the side. The spider had come down at *b*, undoubtedly during the night while the ants were quiet, unconscious of the purpose of their terrible enemy, dug the hole in the center of this hall-way, and covered it with a trap-door before the ants were stirring at the break of day. The soil was in a good condition for tracing out the tube, which I did very carefully and found neither branch nor second door, so that this nest was of the type *single cork door, unbranched nest*.

The fifth I collected on the same day and not more than 10 feet distant. Turning over a stone I saw a tube which ran down one of the perpendicular sides of the hole, in which the rock fitted, then along the bottom to near the center of where the stone lay. Here it disappeared taking a

perpendicular direction again. I ran a straw down this tube and felt the movements of the spider. The spider would not seize the straw, as they sometimes will, and soon I could no longer feel the movements. I then dug carefully around the tube, and at the depth of about ten inches struck the spider, splitting open its caput. This happened because the spider was in the branch: when I first ran the straw into the tubes she was in the main tube, and probably being frightened ran into the branch and caught hold of the door. This confirms what Mr. Moggridge believes to be the case with spiders making a double door branched nest, that when an enemy succeeds in getting entrance to the main tube the spider will run into the branch.¹ This nest is represented in fig. 15, Plate IV. Though the tube is represented nearly natural size the length is much fore-shortened. The space represented by the dotted lines *a* and *b* was 10 inches for each. The spider was found at *b*; the cork door can be seen at *c*.

Another specimen was found, about which, unfortunately, I have no record or recollection, except that it was collected sometime during the spring. This, though I have not given it a careful examination I believe to belong to the same species. I left it in the possession of Dr. Geo. Marx, at Washington.

The specimen collected Apr. 6, I placed in a jar of earth to see what kind of a nest it made in captivity. For several days it showed no signs of working. Finally I found it buried in the earth much as *Nidivalcata murcii* is, when having just completed the dome over the tube, and from the appearance of things I think the burrow was started, and the dome made in the same way as in the case of that species. The next day in place of the dome, in which there was no moss, was a perfect cork door with an abundance of moss in it. The spider had evidently cleared away the dome, which was made of earth and silk, and made the door of new material.

When I lifted up this door the spider would catch hold of it. In a few days I found this door fastened down and that end of the tube filled with earth for a distance of 5 cm. The tube extended in a circuitous direction for 10 cm. or more where it came to the surface and was closed by another nicely fitting trap-door: I think the spider was alarmed at

¹Harvesting Ants and Trap-Door Spiders.

the discovery of her nest, and attempted by this strategy to deceive her enemy. If the jar of earth had been more capacious, and a longer time given the spider, she might have made a branch and second door.

Food habits. I have not yet had an opportunity of making very extensive observations on the food habits of these species, and cannot say that each one is confined to the insect for which I am certain it has a special fondness as an article of diet. Of the species of *Pachylomerus* my observations have been confined to *P. carabivorus*. I have already stated the fondness which this species has for carabid beetles, and though killing several ants and flies did not use them for food. During July, while at Ithaca, N. Y., I fed several carabid beetles to a *P. carabivorus* which I had alive. June 20, I placed a '*Pterostichus lucublambus*', Say, in the bottle containing the nest of the spider. During the night the spider came out of the nest, caught the beetle, ate it and ejected the hard parts from the nest. July 1st, it disposed of a '*Pterostichus Sayi*', Brulle. June 29 it ate a beetle of the genus *Chlænius*. At another time it ate three good sized beetles of the genus *Chlænius* in one night.

The observations which I made on *Nidivalvata Marxii* in captivity are very interesting. I noticed that at night the spider would throw its doors wide open² as shown in fig. 17, Plate IV. One evening I placed several in the jar containing the nest. When an ant approached so near the door as to send communication to the spider of its presence, the spider sprang to the entrance, caught a door with the anterior legs

¹ I am indebted to Prof. J. A. Comstock for the identification of the species of beetles.

² The position of *Nidivalvata* in the subfamily *Eriodontiæ* shows its near relation to the *Atypicæ*. I have often been struck with its likeness to the *Atypicæ*, especially in the kind of a nest it makes, and though I have never seen an *Atypus*, nor one of its nests, I have often concluded that from the form of its nest it must be somewhat similar to *Nidivalvata* in architectural habit, and that the presence of a door, or covering for the entrance to its nest instead of being wanting, has been overlooked; that in the cases where the nest was open, accident had removed the door. What O. P. Cambridge says in *Annals of Nat. Hist.* 4th series 1875, Vol. XVI, p. 240-241, seems to me to indicate that *Atypus* is very similar in habit to this genus. Not only in the form of the nest, but in its food habit. He says that on one occasion a nest which apparently had no orifice was buried in a box of earth; subsequently the tube was observed with a wide open mouth, and again was closed the following morning. The spider probably opens the doors at night to watch for food, and closes them in the morning as does *N. marxii*.

on either side, and pulled them nearly together, so that there was just space enough left for it to see the ant when it crossed the opening. When this happened, the spider threw the doors wide open, caught the ant, and in the twinkling of an eye had dropped back to the bottom of the tube with its game. This I saw repeated several times during the months of January and February. At one time I placed a large cricket in the jar. The spider made several attempts to capture it but was not strong enough. It would probably eat crickets when fortunate enough to catch one. I think also that it would eat small carabid beetles, for I found several in the moss where I collected the spider. I have found the remains of ants in the nests.

I have made no observations on *Myrmekiaphila foliata* in captivity, but from the location of their nests it is quite evident that the members of this species are extremely fond of ants, and seek to build their nests either directly in an ants nest or in close proximity to it. I think in some cases it is intended that the main tube shall be used as a passage for ants, so that by coming out of the branch the spider can capture its food, for it is certain in these which I have observed that the external door is either wanting or old and in a neglected condition, while the door at the branch is kept well repaired. If I am correct in this conclusion it would account for the apparent variation noticed in the kind of nest built by this species. In the nest represented in fig. 16, Plate IV, the entrance *b*, and the landing *a*, *a*, of the ants' nest answers for the main tube of the spider, and only the one tube and trap-door is required for the use of the spider.¹

¹ NOTE.—There evidently is quite a variation, even with the same species, in the kind of a nest which trap-door spiders make. As these prove to be very intelligent creatures, I believe they vary in the construction of the nest as the conditions of their environment varies, and that they adopt that plan which provides for them the safest abode, and at the same time will serve them the best as a trap. At the same time we must not lose sight of a common type, which, with some useful variations, each species follows; though species of different genera may make the same kind of a nest, and be identical in food habit, species of the same genus may vary with regard to the common type; so that the use of nests, and food habits, becomes of less value than has been heretofore supposed by some for purposes of classification.

Mr. Moggridge says, "H. A. and T. D. Spiders" Supplement, pp. 236, and 237; the range and distribution of a species largely depend upon the nature of its food, and this will also be an indication of the rivals, etc.—"and in many cases even the *structure* and *position* of its dwelling place will be governed by this same all-important question of food supply.

Rev. O. P. Cambridge, at that time came to this conclusion, "and in

DESCRIPTIONS.

Prefatory Note. It is not surprising that in a collection of some forty specimens there would be found several species, nor that a large number of these would prove to be new and undescribed forms, where so little attention has been given to spiders in general, and especially those of the order *Territelariæ*, as has been given in America.

It has been a great pleasure to me to observe the nests and habits of so many of these creatures, which by their solitary and secluded life generally escape our observation. It has seemed necessary, that, in connection with interesting descriptions of their nests, architectural and food habits, these forms should be described and named. So interested have I become during the past year in the work of N. M. Hentz, that it would have given me more pleasure to find a specimen described by him than to find a new form. I feel sure that I have found one of his species, and possibly one other related species. I undertook the work of description with great reluctance, and have found it to be no small task. But my labors have been greatly lessened and I have been sensibly encouraged by the kindness of Dr. George Marx, of Washington, Prof. J. H. Emerton and Samuel Henshaw, of Boston. Dr. Marx loaned me works from his private library, Prof. Emerton placed for my study his excellent collection of Arachnological publications, and specimens for comparison, which are now in the Mass. Inst. Tech., and showed me further kindness in directing me to the most useful works in the Library of the Boston Natural History Society. Mr. Henshaw also aided me in the same way and gave me the use of the specimens of *Territelariæ* which are in the Museum of the Society.

I have also found works in the Boston Public Library which have aided me.

In the value of generic and specific characters I have been

the present case it is very important, as well as interesting, to conclude with some certainty that differences of type in the tubular nests of the spiders Mr. Mcgridge has observed so closely and accurately, are joined to well marked specific differences etc. "Harvesting Ants and Trap-Door Spiders, Supplement p 301." Later, Cambridge doubts such close union of specific character and architectural habit, for he finds nests of *Atypus piceus* varying greatly in construction. (Annals of Nat. Hist. 1878, 5th series, Vol. 1, p. 107.) From nests made in captivity, I know that *Pachylomerus turris* and *Nidivalvata angustata* make different nests according as the environments change.

guided by those adopted by Anton Ausserer¹, and the Rev. O. P. Cambridge², who have given considerable study to members of the *Territelariæ*.

I have followed the classification adopted by Ausserer in his *Beitrag zur Kenntniss der Territelariæ*.

I subjoin, for clearness, a brief synopsis of his Classification.

Suborder *Territelariæ*. This was divided by Thorell into 3 families, as follows :

- 2, lung sacs..... *Catadisoidæ*.
 4, lung sacks,
 a. Without spinnerets..... *Liphistoidiæ*.
 b. With spinnerets..... *Theraphosoidæ*.

The family *Theraphosoidæ*, Thorell, is further divided into three subfamilies as follows :

- Maxillæ well broadened at the base, palpi inserted laterally, .**Atypinæ** Thorell
 Maxillæ little broadened at base, palpi inserted laterally.....
Eriodontinæ Ausserer.
 Maxillæ not broadened at base, palpi inserted on the end,.....
Theraphosinæ Thorell.

The *Theraphosoidæ* are then further divided into two groups, based on the relative elevation of the caput above the throax.

- a. Caput well elevated,..... *Epicephali*.
 b. Caput not much elevated, *Tapinocephali*.

In specific descriptions I have endeavored to not repeat characters which seem at present generic, so that in most cases it will require both the generic and specific characters to identify a single species ; for this reason I have given the characters of the genus *Pachylomerus*, established by Ausserer.

Family **THERAPHOSOIDÆ**, Thorell.

Subfamily **Eriodontinæ**, Auss.

1. Genus **Nidivalvata**, n. gen.

(*nidus*, nest, *valvata*, having folding doors.)

(Pl. V, figs. 8, 9, 10, 13, 23.)

Ceph'x little longer than broad ; greatest breadth at middle, tapering very gently and equally to both ends ; edges of posterior half slightly scalloped ; small, deep, circular, depression in center from which radiate to edges of ceph'x 6 depressed lines quite well marked. Caput well elevated, sloping to thorax gently, not broadly arched as in *Myrmekiaphila*. In front, caput gently drawn to a short, blunt point about which the eyes

¹ Beitræge zur Kenntniss der Terrielarix, Auss. 1871, and Zweit.r Beitrag, etc., 1876.

² Encyclopedia Britannica, 9th, Ed. pp. 291 and 597, Harvesting Ants and Trap Door Spiders, Moggridge, and Supplement.

are crowded. Eyes can be better described by speaking of them as being in three groups; the anti-centrals a diameter or less distant and situated at the top and on sides of the hill; on each side of these, not far separated is a group of three eyes forming a crescent with the concavity toward the middle group; the eyes in this group nearly or quite touch each other. Fig 8, Pl. V, represents the eyes as seen from the front at an angle of 45° to a plane parallel with the base of the ceph'x

With this view the ant- and post-laterals form a trapezium, base at post-laterals one-fourth larger than opposite side; height about one-third of base, post centrals slightly in front of base of trapezium. Ant-laterals comparatively large; others varying in relative size in different species, and it may be found that the relative position varies also as in *Pachylomerus*. Maxillæ extended in front, but not so much as in *Eriodon*. Fig. 10 represents a maxilla showing insertion of palpus. Labium triangular, distal end rounded, longer than broad at base. Mandibles strongly knee'd in front of perpendicular clypeus.

About half or less than half as long as ceph'x, broad and deep, armed with a comparatively strong fang; the inner edge only of furrow for reception of fang armed with teeth; upper and inner edges of anterior half armed with short spines, which also extend part way around base of fang.

Legs 4, 1, 3, 2. 4, 1, 2, 3, or 4, 1, 2, 3; palpi long. 3 tarsal claws. Claw of palpus unarmed. Abdomen short oval. Spinnerets 4, the upper pair long and slender.

1. *Nidivalvata marxii*, n. sp.¹ female 1 specimen.

(Pl. V, figs, 8, 9, 10, 13, 23.)

Ceph'x broadly oval 6 mm long by 5 mm. broad. Caput back of ocular prominence not perceptibly elevated, slope down to depression in center of ceph'x gradual. Caput in front not much contracted on sides.

Radial depressions all quite deep; the posterior one of the laterals on each side, seeming to unite with the central depression. The depressions, though distinct in this specimen, have deepened somewhat by alternately being in alcohol and in the air while being studied.

In each anterior radial depression on sides of base of caput is a well marked depression, though not deep.

Post-central eyes fully as large as the ant-centrals, eyes of the outer group almost or quite touching. Ant-laterals dark orange, remainder transparent, legs 4, 1, 3, 2. 3rd 12 mm., 2d $11\frac{1}{2}$ mm. Sternum longer than broad, with three distinct circular punctures on each side. Abdomen broadly oval and bluntly rounded at each end; on ventral surface narrowed in front.

Armature Very few hairs; short and fine on abdomen, longer and darker on the 4 distal joints of legs. Metatarsus IV, with a row of spines on each side, and one on under side, with additional spines at each end; tibia IV, with few long spines irregularly placed on upper side, 3 distinct rows, two on under side and one on anterior side, with extra spines at each end. Patella two double rows of spines on upper surface. Metatarsus III, 4 rows of spines, two upper and two lower edge: spines irregularly placed on upper side. Patella III, patch of spines on upper anterior surface, broadest at distal end; this is separated from a few spines on the posterior surface by an oblique denuded line. Metatarsus II, two double rows of spines, one on anterior surface, and one of long spines on under surface; tibia II and I, double row of long spines on under surface, and single row of short spines on anterior surface. Met-

¹ In honor of Dr. Geo. Marx.

atarsus I, three rows of long spines on under and anterior surface. Palpus, tarsus and tibia a somewhat double row of long spines on each side; patella, one or two spines on anterior surface.

Labium separated from sternum by a deep furrow.

Colors. Upper surface Ceph'x and legs, olive brown. Under surface legs dull yellowish. Sternum a little darker. Maxillæ dull rufous, with reddish hairs. Ocular prominence black. Abdomen dull yellowish underneath, brownish yellow above, with two rectangular rich dark brown spots on anterior end. Mandibles rufous. Colors little changed in alcohol, not so bright however, and marks on abdomen disappeared.

2. *Nidivalvata angustata* n. sp. female 2, specimens.

Ceph'x oblong, $5\frac{1}{2}$ mm long by 4 mm broad. Caput in front below eyes perceptibly narrowed; caudad of ocular prominence perceptibly elevated, making the descent to the thorax steeper than in *N. marxi*. Legs 4, 1, 2, 3. Anterior central and lateral eyes dark, the others light; posterior centrals much smaller comparatively than in *N. marxi*, and the lateral groups of three distinctly separated. Radial furrows on thorax not so deep as in *N. marxi*. Otherwise the same.

II Genus MYRMEKIAPHILA, n. gen.

(*murmekia*, ants' nest or hill *philos* loving)

(Pl, V, figs. 6, 7, 12, 14 and 22.)

Ceph'x perceptibly longer than broad, nearly $\frac{1}{2}$: crescent shaped depression $\frac{1}{3}$ distance from posterior edge, convexity caudad, ends not so extended as in *Pachylomerus*; 6 radial lines, sometimes quite indistinct. Greatest width about the middle, narrowing gently to the anterior end, and more perceptibly toward posterior end.

Caput large, high and broadly arched in the anterior $\frac{2}{3}$, then steeply descending to depression and narrowing on the sides to this point.

Eyes. Anterior and posterior laterals forming a rectangle, the height of which is equal to two fifths the base. Ant-laterals oval, largest; post-centrals near the post laterals; ant-centrals in a line about $\frac{2}{3}$ from base of rectangle. Legs 4, 1, 2, 3. Labium, trapezoidal, shorter than broad at base. Maxillæ extending forward not quite so much in proportion as in *Nidivalvata*. See fig 12, Plate V.

Mandibles, half or more than half as long as ceph'x slightly kneed in front of margin of caput, armed with a strong fang.

Inner edge only of groove for reception of fang armed with short teeth; front of mandible, on the inside of the insertion of fang drawn out into a three cornered toothed projection, much as in *Pachylomerus*, but a little smaller; short teeth along anterior half of inner upper edge of mandibles, and few at base of fang. Abdomen elongate, cylindrical, tapering gently to each end. Spinnerets 4, upper pair medium size and length.

I have been somewhat in doubt about placing this genus in the subfamily *Eriodontinae*, as it has some affinities with members of the subfamily *Theraphosinae*, division *Æpicephali*. But I think, after a comparison of the maxillæ, with those of *Cteniza*, *Nemesia*, and *Eurypelma*, some species of which have a prolongation of the inner distal end, that the character of the maxillæ would place it in the subfamily *Eriodontinae*. If, however, it should prove to belong to the *Theraphosinae*, it would constitute a genus related with, *Aepycephalus*, *Cteniza*, *Cytocarenum*, and *Cyrtauchenius*, in the

group *Aepycephali*. It can, however, be separated easily from these genera by the following characters.¹

Aepycephalus. 'Head high and somewhat pointed, ceph'x broad as long, side eyes form a trapezium, lip broad as long, etc.'

Oteniza. "Side eyes from a trapezium. Lip somewhat three cornered, spinnerets short and thick. Abdomen great, eggformet, etc."

Cyrtocarenum. 'Ceph'x as in *Oteniza*; but head broader in front. Eyes occupy whole breadth of head, abdomen and spinnerets as in *Oteniza*, etc.'

Cyrtlauchenius. "Form of Ceph'x, and position of eyes as in *Cyrtocarenum*, mandibles not drawn into a point, etc."

As the nesting and food habits singularly resemble those of members of the genus *Nemesia*, and the form of the abdomen also, it might be confounded with that genus, which belongs to the group of *Theraphosinae* called *Tapinocephali*, as *Nemesiai*, as being related to the genera above mentioned represents the passage from the *Aepycephali* to the *Tapinocephali*. The generic characters given by Ausserer² however easily distinguished it.

Nemesia. "Head low, little elevated above the thorax. Depression with the concavity behind"

The specimen of *Nemesia caementaria* which I saw in the Museum of the Boston Soc. of Nat. Hist. is readily distinguished generically from this.

1. *Myrmekiaphila foliata*, n. sp. female 5 specimens. (Pl. V, figs. 6, 7, 12, 14, and 22)

In addition to the generic characters are the following specific characters. Anterior central eyes³ situated from each other about one diameter. Posterior lateral eyes a little larger than the ant-centrals. Post-centrals slightly angulated a little smaller than the ant-centrals, each one about a diameter distant from the corresponding post lateral, and situated a very little cephalad of the base of rectangle bounding the lateral eyes. Ant-centrals on point of hill higher than the others. Ant-laterals lowest; these and the post-laterals situated at base of the low hill for the eyes.

Legs of one of largest specimens. 4th, 21 mm. 3d, 14½ mm. 2d, 16 mm. 1st, 17 mm., palpus 15 mm. Ceph'x 9 x 7 mm.

In the anterior radial lines, on each side of the caput is an elongated shallow depression. Two lateral radials on each side show a long, narrow, shallow depression, post radials indistinct in some. Edges of ceph'x slightly crenate, and showing shallow, irregular depressions: posterior margin emarginate. Caput 3.5 mm. elevated above thorax.

Sternum 5 mm. long by 3.75 mm. broad, broadest part one-third distance from posterior end, distinctly angled. Labium slightly emarginate. Abdomen 10 mm. long by 7 mm. broad.

Armature. Very few hairs, more perceptible on abdomen, and still more so on the three and four distal joints of the legs, where the hairs are

¹ Beiträge zur Kenntniss der Territelariæ, Auss pp. 150, 151, 152, 156 and 161.

² Beiträge zur Kenntniss der Territelariæ, Auss. p. 165.

³ It seems unnecessary to repeat the description of the eyes so far as given for the genus. Some variation should, however, be allowed for other species which may be found.

darker. Tarsus IV one or two spines on anterior side. Metatarsus IV with four or five long spines on under side, distal end 1 or 2 near centre. Tibia IV with scattered stiff hairs. Patella IV, upper and anterior side with numerous slender spines, with quite a strong base. A broad longitudinal denuded space on upper side, divides this patch of hairs. Femur IV with a number of spines on distal upper end. Tarsus III, 2 spines on under side. Metatarsus III, 1 or 2 spines on under, distal end, 1 or 2 more near middle; two rows 3 or 4 spines each on upper anterior, and posterior edge. Upper surface of tibia and patella III, covered with spines, which are divided into two patches by an oblique, denuded, narrow space. Tibia III, shorter than patella III. Tarsus II, 1 or 2 spines on posterior under edge; metatarsus II and I with 2 or 3 spines on under, distal end, and 2 or three near middle. Dense row of hairs on anterior and posterior side of tarsus and metatarsus I; palpus, tarsus as in I; tibia with spine on under distal end, and one or two near middle. Labium separated from sternum by a deep furrow. Maxillæ and labium with very short, brown, strong spines at the oral extremities.

Colors Ceph'x dull olive with a rufous tinge; legs more decidedly rufous, except the femora which are paler and indistinctly tinged with green. Mandibles, sternum, maxillæ and labium decidedly rufous. Ends of mandibles darker. Ocular prominence black; posterior eyes light; others usually black. Abdomen dull yellowish; broad longitudinal dorsal band of delicate brown, from which branch on each side 7 bands of same color, extending down midway of abdomen. Above colors from acoholic specimens. In some specimens the alcohol has entirely effaced the foliation on the abdomen, but it was distinct in all the specimens when alive. When alive the femora were of a delicate light, olive green.

Subfamily THERAPHOSINÆ.

Group Æpicephalii

I. Genus *PACHYLOMERUS* Ausserer.

"Cephalothorax nur wenig länger als breit, lang, nach hinten allmählig abfallend. Die halbkreisförmige, nach vorn geöffnete Ruckengrube etwas hochliegend, da von hier der Thorax nach hinten noch fast unter demselben Winkel sich abdacht wie der Kopf, während bei verwandten Gattungen hinter der Grube der Thorax fast horizontal verläuft.—Augen etwas gedrängt, auf niedrigem Hügel. Die vier ovalen Seitenaugen die grössten, mitsammen ein Rechteck bildend, dessen Höhe gleich der halben Basis. Vordere Mittelaugen höher stehend als die Seitenaugen. Mandibles stark, wenig länger als hoch, in eine mit Dornen bewaffnete Spitze vorgezogen. Falzrand beiderseits mit einer Reihe starker Zähne bewaffnet. Lippe so lang, als am Grunde breit, vorn zugespitzt. Die Extremitäten der beiden Hinterpaare auffallend verdickt, ihre Schenkel in der untern Hälfte bauchig aufgetrieben. Tibia III kürzer als Patella III, oben an der Wurzel mit tiefem Eindrucke. Die beiden vorderen Fusspaare und die Palpen female etwas schwach, ihre beiden Endglieder unten flach und beiderseits mit einem breiten Bande kürzer, stärker, dichtgedrängter Stacheln bewaffnet. Abdomen mässig gross, eiförmig, Spinwarzen vier, etwas dick und kurz,"¹

Ausserer takes *P. glaber* Dall, as type of this genus and says "ob die uebrigen vorläufig hier eingereihten Arten wirklich hierher gehören, lasst sich bei den etwas mangelhaften Beschreibungen nicht mit voller Sicherheit bestimmen."²

¹ Beiträge zur Kenntniss der Territelariæ, Auss., p. 145 and 146.

² Idem, p. 146.

P. carolinensis Hentz, was one of those to which he refers. I think he was right in placing it in this genus, but for the relative position of the eyes, and some slight difference in the form of the labium there should be allowed some variation in generic character, which he undoubtedly would have done, had he the opportunity to see the specimens.

1. *Pachylomerus carabivorus*, n. sp. female. 5 specimens. (Plate V, figs 1 and 4, and 20.)

Eyes. Anterior and posterior laterals forming a trapezium; base of which formed by the post-laterals one-fifth longer than the opposite side. Height about one-third of base. View of eyes taken perpendicularly to a plane parallel with the ventral surface of the ceph'x. With this view the ant- and post lateral eyes appear elliptical in outline; but viewed from a point toward which each eye may be said to "look" they are nearly circular in outline, and appear like "dormer windows," from the arched portion of the caput for each one. Fig. 3, Plate V, represents position and relative size of the eyes as seen from the view explained above; the arrows indicate the direction from which the greater number of rays of light enter the eyes. A line through the center of the ant-central eyes would pass a little above a line half way between the base and opposite side of the trapezium; ant-centrals are situated from each other, and from the ant-laterals about one diameter; receive the rays of light directly from above. Post-lateral eyes in line with base of trapezium, or a trifle anterior in some specimens, receive the rays of light from a point caudo-dorsal. Ant-lateral, largest, ant-central and post-lateral of about equal size, post-central smallest, though in one specimen they are of equal size with the ant-central and post-lateral.

Ceph'x a little longer than broad at widest part. In one specimen 9 mm. x 8.25 mm., another 11 mm. x 10 mm...&c. U-shaped depression situated about two-thirds of the distance from the anterior margin of the caput. Base of ceph'x 3.5 mm.; posterior angles quite sharply denuded; lateral edge, from posterior angle to point of greatest width, straight. Greatest height of ceph'x, 6 mm. Mandibles 3.5 mm. long x 3 mm. deep. Abdomen 12 mm. long, whole length of spider 24.5 mm. Legs: 1st, 16 mm.; 2d, 15.25 mm.; 3rd, 15-25 mm.; 4th, 19.5 mm. These are measurements taken from one individual. In some the legs are 4, 1, 2, 3.

Armature. The legs have few hairs, though more abundant on tibia, metatarsus and tarsus, of all the legs, and patella III and IV.

Patella IV on sides of proximal half covered with very short spines. Anterior side of metatarsus and tarsus IV slender spines; a few spines on under side, distal end of tibia IV. Trochanter III with a short papilla. Anterior side and upper distal end of patella III, whole upper surface of metatarsus III, and distal end of tibia III, covered with short, strong, black spines. On upper side of proximal end of metatarsus III is an elongated denuded spot, which seems to be the miniature of the smooth depression at proximal end of tibia III; tarsus III with few spines. Tibia, metatarsus and tarsus of II and I, and tibia and tarsus of palpus, with dense row of short, strong, black spines on anterior and posterior sides.

Sternum with few hairs on edge, longer than broad, in one specimen 6.25 mm. by 5.75 mm., sharply angled between the articulation of the coxæ; greatest breadth between coxæ II and III.

Maxillæ longer than coxa I; at edge of base a clustered row of short, strong, brown spines; densely hairy with rufous hairs on anterior edge. Labium broadest at base, distal end truncate, anterior angles well

rounded; as long or nearly as long as broad at base; armed near distal end with a few spines similar to those on the maxillæ; separated from the sternum by a deep furrow.

Colors. When alive. Ceph'x and legs deep glossy black. Abdomen light brown. Ends of mandibles, hairs on end of mandibles, and on anterior edge of maxillæ reddish. Patella IV also reddish on upper surface. Under parts lighter colored. Membrane connecting legs to cep'x and the joints of the legs whitish. When placed in alcohol the glossy black after a while disappears, and becomes a dark rufous brown, ends of legs remaining darker because of the presence of numerous very short, black spines.

***Pachylomerus carabivorus*, var. *emarginatus*, n. var.** (female 1 specimen.)

This seems to be a varietal form of *P. carabivorus*. Labium trapezoidal, anterior corners rounded; shorter than broad at base. Ceph'x nearly as broad as long, 10 mm. long. Marginal configuration as in *P. carabivorus*, except that the posterior margin is strongly emarginate. Whole upper portion of cep'x seems to be elevated, showing quite a breadth of membrane which connects it with the coxæ. Middle portion of caput, perceptibly elevated and broadened a little caudad of the eyes. Legs: 4th, 23.5 mm; 3rd, 19.25 mm; 2d, 18.5 mm; 1st, 20 mm. In front of the U-shaped depression the caput is emarginate, the depression extending for a short distance cephalad in the median line. This is seen to a certain extent in some good specimens of *P. carabivorus*. Otherwise as in *P. carabivorus*.

***Pachylomerus carolinensis*, Hentz.** female 1 specimen. (Plate V, figs 2 and 3, and 20.) *Beitrag zur Kenntniss der Terr tetariae*, Ausserer, 1871, p. 147. *Mygale carolinensis*, Hentz, Boston Journ IV, p. 55, pl. VII, fig 3.

This specimen I am convinced is the same as the one described by Hentz as *Mygale carolinensis*. The description is very imperfect, and I take this opportunity of making it a little more complete, and easy to identify. His description is as follows: "Brownish, very glossy; cephalic thorax with two slight impressions near the base; abdomen blackish, not glossy; third joint of the third pair of legs very short and crooked; feet 4, 1, 3, 2." The spinal armature is the same as in *P. carabivorus*, but the cep'x and arrangement of eyes are quite distinct. Ceph'x longer in proportion to width than in *P. carabivorus*, 10 mm. x 8 mm. in this specimen. U-shaped depression situated more than two-thirds the distance from anterior margin of caput, making caput larger in proportion. In the curve of the U shaped depression, there is scarcely any depression; a very faintly depressed line, which is quite readily seen because it is very dark, connects the two well marked depressions at the anterior ends of the U. As Hentz's specimen was a small one, these depressions would be smaller than in the specimen I have. Had it been a well marked U-shaped depression, he would have noted it, as he has in the case of *Mygale truncata*.¹

Caput caudad of eyes slightly elevated, making the slope quite steep.

Radial depressions distinct, straight. Base of cep'x 4 mm; angles not sharply defined; lateral edge from posterior angle to point of greatest breadth curved, with convexity outward, fig. 2, pl. V, represents the cep'x of this species. By comparing it with fig. 1, can be seen the differences of the two species in the configuration and markings.² Fig. 3

¹ Boston Journ. IV, p. 55. Spiders of the U. S. N. M. Hentz, p. 16, pl. I, fig i.

² The curvature of the lateral radials I do not think is constant.

represents the eyes of *P. carolinensis*; fig. 4 of *P. carabivorus*; fig. 19 tarsal claw, spur at base with a small spine on each side at its base; distad of this a spine divided at the end. Labium as long or longer than broad at base.

Eyes. Ant- and post-laterals form a trapezium as in *P. carabivorus*, but the ant centrals are situated on a line halfway between the base of the trapezium and the opposite side; the post-laterals and centrals form a curved line with convexity caudad, instead of a straight line as in *P. carabivorus*.

Sternum as broad as long, 5 mm., broadest part one third from caudal end.

*Mygale solstitialis.*¹ Hentz: I am inclined to think, is the male of this species. The depressions in the ceph'x are similar, the difference in the lengths of the 2d and 3rd pair of legs is not of much specific importance in many species. The depressions on the abdomen are just what will appear in any of these species, when the abdomen becomes small for want of food, or after the depositing of eggs. In nearly all specimens either one, two, or three, or more pair of circular depressions can be seen. When the abdomen shrinks the space between the depressed dots of each pair becomes depressed in the form of a rectangle as seen in Hentz's figure of *Mygale solstitialis*. The difference in color of the two is not of specific importance, for the young of *P. carabivorus* have a brownish ceph'x, the old a glossy black, and when transferred to alcohol, this soon changes to brown.

***Pachylomerus turris*, n. sp.** female, 1 specimen. (Pl. V, fig. 5)

Ceph'x 6.5 mm long x 6 mm broad. Marginal configuration as in *P. carabivorus*; lateral radial depressions in form of crescents with the concavities caudad; anterior radial depressions indistinct, but marked by a deep, small cylindrical puncture; armature same as *P. carabivorus*, with the exception of the lack here and there of a few spines, which may be accidental.

Sternum nearly as broad as long, distinctly angled between articulations of coxæ. Labium shorter than broad at base, nearly triangular, separated from sternum by a furrow.

Eyes. Upon the arrangement of the eyes is laid the greatest stress in establishing this species. Ant- and post laterals forming a rectangle; posterior row curved with the convexity caudad.

Tuft of hairs on clypeus with few hairs; also very few hairs or signs of their having been any, in the three lines caudad of the eyes.

***Pachylomerus 4-spincsus*, n. sp.** (Pl. V, fig. 21.)

Eyes as in *P. carolinensis*. Legs 4, 1, 3, 2, tibia III with depression at proximal end, but distal end not enlarged as in the other species. Armature very distinct from the other species. Patella IV with a number of spines; distal end of patella and metatarsus III, two spines; two on proximal end of metatarsus and two or three on distal end of tibia III; row of spine on each lower side of II and I, arranged thus in each row, one on tarsus, two on metatarsus, and two on tibia; palpus with a row

¹ Boston journ. IV. p. 56. Spiders of the U. S. N. M. Hentz, p. 17, pl. 1. f. 3,

on each lower side, arranged 3 on tarsus, 2 on tibia, one on patella, and one on femur. Spines at base of maxillæ and on labium as in the other species of *Pachylomerus*. All the spines on the legs are medium length, and not short as in the other species. Cep'h'x and legs pale rufous, abdomen light brown. Specimens young. Palpal claw is shown in fig. 21, plate V, at base is a large short spine, which has four divisions at the terminal end, the distal one the longest, and the others decreasing successively in length.

EXPLANATION OF PLATE V.

- Fig. 1 Cep'h'x of *Pachylomerus carabivorus*.
 " 2. " " " *carolinensis*.
 " 3. Eyes of " "
 " 4. " " " *carabivorus*.
 " 5. " " " *turris*.
 " 6. *Myrmekiaphila foliata*, dorsal view.
 " 7. " " " eyes of.
 " 12. " " " maxilla of.
 " 14. " " " side view.
 " 9. *Nidivalvata marxii*, dorsal view.
 " 8. " " " eyes of.
 " 10. " " " maxillæ of.
 " 13. " " " side view.
 " 11. " *angustata*, nest of.
 " 15. Nest of *Myrmekiaphila foliata*; dotted line at *a* represents bottom of place where stone lay. Space represented by dotted lines *a* and *d*, much further shortened; *b*, where spider was caught; *c*, trap door.
 " 16. Nest of *Myrmekiaphila foliata* in an ant's nest; *a*, landing in ant's nest, leading off into galleries; *b*, entrance to ant's nest, *d*, tube of spider; *c*, trap-door.
 " 17. Nest of *Nidivalvata marxii*, open.
 " 18. " " " " closed.
 " 19. Palpal claw female, of *P. carolinensis*.
 " 20. " " " " *P. carabivorus*.
 " 21. Palpal claw of *P. 4-spinosus*.
 " 22. " " female of *M. foliata*.
 " 23. " " " " *N. marxii*.
 Figs. 1, 2, 6, 9, 13 and 14, about natural size.

SOME NEW SALTS OF CAMPHORIC ACID.

I. H. MANNING.

Although this acid has been known for over one hundred years, comparatively few of its salts have been prepared and studied. The present work was undertaken with a view of extending this list, but was interrupted before very many additions could be made.

The camphoric acid was prepared, according to the directions of Wreden, by dissolving 150 grams of camphor in 2 litres of nitric acid, sp. gr., 1.27, and heating the solution 50 hours on the water bath. The liquid was then saturated with sodium carbonate, filtered, neutralized with hydrochloric



fig. 1.



fig. 2.



fig. 3.



fig. 4.



fig. 5.



fig. 6.



fig. 7.



fig. 8.



fig. 9.

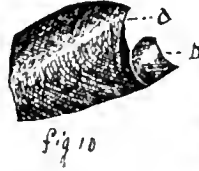

fig. 10.

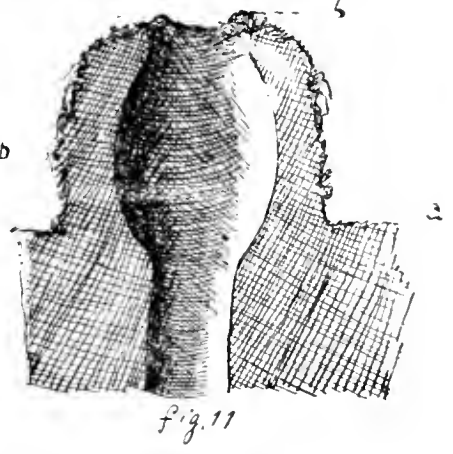

fig. 11.



fig. 12.



fig. 13.



fig. 14.

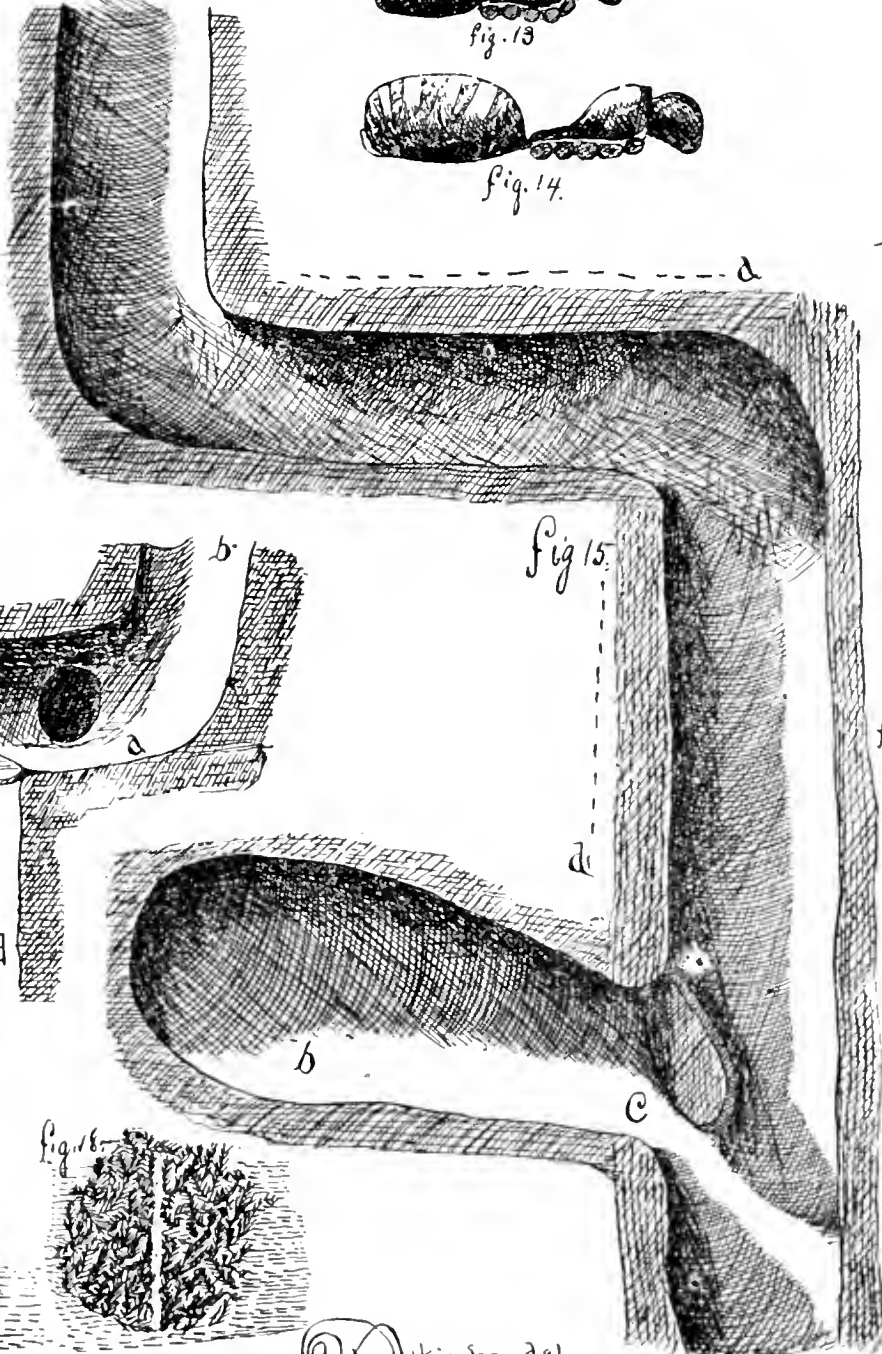

fig. 15.

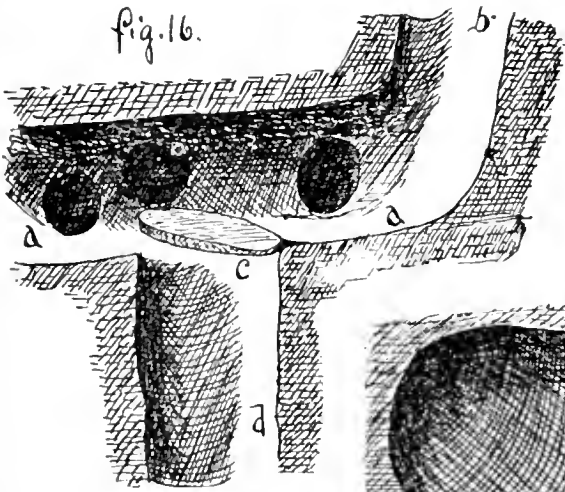

fig. 16.



fig. 19.



fig. 20.



fig. 21.



fig. 22.

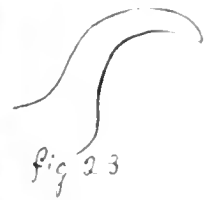

fig. 23.



fig. 17.

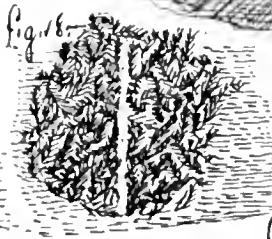

fig. 18.

W. Atkinson. del.



acid, and the separated camphoric acid purified by crystallizing from water. The yield was about the same as that obtained by Wreden, when great care was exercised in the purification by crystallizing from water. The pure crystals gave the melting point 176°C . (uncorrected). A ten per cent. solution of caustic potash was saturated with camphoric acid and the solution of potassium camphorate so obtained was used in preparing the other compounds.

MANGANESE CAMPHORATE. When a few drops of potassium camphorate were added to a nearly saturated solution of manganese sulphate in a small watch-glass, no precipitate was formed until it had been heated on the water-bath. A white amorphous precipitate was then gotten, which was easily soluble in cold water. This could always be reprecipitated on heating. In preparing the salt on a larger scale the mixture of potassium camphorate and manganese sulphate was heated to precipitation and the precipitate well washed with hot water. The precipitate was then dried at 100° . If exposed in the moist condition it showed browning. There was a slight discoloration even when rapidly dried. At 150° decomposition was very slight; at 200° it was marked. When some of the purified manganese camphorate was dissolved in water and evaporated over sulphuric acid a crust of the salt was obtained, but no crystal.

Analysis.

| | | | | | |
|------|-------|----------------------|------|-------|----------------------------------|
| I. | .2790 | grammes of substance | gave | .0859 | grammes, Mn_2O_3 |
| II. | .4460 | “ “ “ | “ | .1330 | “ “ |
| III. | .4375 | “ “ “ | “ | .1330 | “ “ |

I and III was determined by precipitation as carbonate, II by ignition.

| | | | | | | |
|--|-----------|-------|-------|----------|-----------|------------|
| Mn. $\text{C}_{10}\text{H}_{14}\text{O}_4$ | p. c. Mn. | calc. | found | I. 22.07 | II. 21.39 | III. 22.50 |
|--|-----------|-------|-------|----------|-----------|------------|

As it was very difficult to wash away all of the potassium camphorate the low results are probably due to the presence of the same as an impurity.

CHROMIUM CAMPHORATE. On adding potassium camphorate to a solution of chromium sulphate a heavy precipitate of a bluish-green color is formed. This is not very soluble and can be thoroughly washed with cold water. It can be dried at 100°C . losing all water at this temperature. Before reaching 150° slow decomposition sets in.

Analysis.

| | | | | | |
|---|----------|----------------------|---------------------|--------------|-------------------------------|
| I. | 4280 | grammes of substance | yielded on ignition | .0810 | gram. Cr_2O_3 |
| II. | 16370 | “ “ “ | “ “ | .1340 | “ Cr_2O_3 |
| $\text{Cr}_2(\text{C}_{10}\text{H}_{14}\text{O}_4)_3$ | p. c. Cr | calc. | found in I. | found in II. | |
| | | 14.81 | 12.93 | 14.40 | |

The sample in I was different from that in II and evidently not so pure.

FERRIC CAMPHORATE. A strong solution of ferric chloride was precipitated with potassium camphorate, a bulky yellowish precipitate was formed, quite insoluble in water and hence easily washed. This gave on drying at 100° a buff-yellow powder. An analysis of this powder gave the percentage of iron as 19.34. The calculated percentage for $\text{Fe}_2(\text{C}_{10}\text{H}_{14}\text{O}_4)_3$ is 15.86. This powder was then probably a subcamphorate. It was treated once more with a moderately strong solution of ferric chloride and again thoroughly washed. Analysis of this gave p.c. $\text{Fe} = 18.84$ and 18.90 .

MERCURIC CAMPHORATE. A white heavy precipitate is formed in a concentrated solution of mercuric chloride on adding potassium camphorate. This was washed thoroughly and dried at 100°C . It forms a heavy white powder.

Analysis.

| | | | |
|--|-----------------------------------|---------------|--------|
| I. | .4400 gramme of substance yielded | .2150 grammes | Fg. |
| II. | .3840 " " " " " | .1920 " " | " " |
| | calculated | found in I. | in II. |
| Hg. | 50.25 | 48.86 | 50.00 |
| $\text{C}_{10}\text{H}_{14}\text{O}_4$ | | | |

Chem. Laboratory, U. N. C.

DECOMPOSITION OF POTASSIUM CYANIDE.

I. H. MANNING.

Under the head of "Condensation of hydrocyanic acid" (Berichteder, d. chem. Ges. 18, 1875) von der Pfordten discusses the discoloration produced in solutions of potassium cyanide by the addition of free acids, or of certain salts, or by simple heating the cyanide alone. This phenomenon was examined and studied to a certain extent by Mr. Wilkes in the first number of our journal (p. 19.) Herr von der Pfordten speaks of the decomposition of the cyanide on heating some hours in a test-tube placed in a water bath, as being due "probably to the long continued action of the carbon dioxide of the air." That this could not be the case was shown by Mr. Wilkes, who proved that the decomposition took place in the cold with all carbon dioxide carefully excluded.

The following experiment were undertaken to test the conclusion of Mr. Wilkes:

1. A saturated or nearly saturated solution of pure potassium cyanide was placed in a tube which was then sealed. Only a very nimute amount of carbon dioxide could have been present, yet the various changes of color were observed and after some weeks the liquid had become black and a blackish deposit had formed.

2. A similarly prepared tube was placed in boiling water; within five minutes a change to brownish-red was noticed, and the color rapidly darkened with the exposure.

3. A similarly prepared tube was fitted with cork and tubes, and while it was in the boiling water carbon dioxide was introduced. The changes were noticed very much as in experiment 2; apparently they were slightly delayed rather than hastened.

4. Into a tube prepared as in 3, hydrogen was passed in a rapid continuous stream. The changes were greatly delayed and no very deep discoloration was obtained.

5. If experiment 3 is so reversed that the carbon dioxide is passed above a cold solution of the cyanide, giving opportunity for its absorption, the change of color is rapid and deep.

From these experiments the conclusion can be drawn that though carbon dioxide hastens the decomposition of the cyanide, as any free acid would do, yet it is not essential for this decomposition.

Chem. Laboratory, U. N. C.

LEAD CHLOR-SULPHO-CYANIDE.

R. G. GRISSOM.

This new compound of lead can be easily prepared by acting on lead chloride with a strong solution of potassium sulpho-cyanide. Freshly precipitated and recrystallized lead chloride was covered with a solution of potassium sulpho-cyanide in excess, and allowed to stand for several days. The liquid was then poured off and the residue treated several times with boiling water until all was dissolved. This fractional solution was carried out to separate, if possible, substances of different solubility. The fractions rapidly deposited crops of crystals on cooling, but examination under the microscope showed that these crystals were identical in crystalline form.

Analyses were made as follows:

| | | | | | | | | | | |
|--------|-------|--------------|------|-------|------|--------------------|----|-------|--------|----|
| .6220 | gram. | of substance | gave | 5.730 | gram | Pb SO ₄ | or | 68.57 | per ct | Pb |
| 1.0280 | " | " | " | .7047 | " | " | or | 68.55 | " | " |

For chlorine and sulphocyanic acid 1.0700 grammes of the substance was dissolved in water and precipitated with silver nitrate. This was filtered and treated with strong nitric acid thus oxidizing the sulpho-cyanide. After dilution it was again filtered. The silver chloride was burned and the sulphuric acid determined in the filtrate in the usual way.

1.0700 grams. of substance yielded .1321 grams. of AgCl or 12.34 per ct. Cl and .8440 grams Ba SO₄ or 19.62 per ct CNS

| | calc. | found | |
|--------------------|-------|-------|-------|
| Pb ₂ | 68.46 | 68.57 | 68.55 |
| Cl ₂ | 11.91 | 12.34 | |
| (CNS) ₂ | 19.41 | 19.63 | |

The formula for the compound then is PbCl₂. Pb(CNS)₂. There is no water of crystallization and the substance can be heated to 150° without decomposition.

The solution poured off from the original lead chlor-sulpho-cyanide yielded mainly crystals of potassium chloride, together with some unchanged potassium sulpho-cyanide. The potassium sulpho-cyanide used was freshly prepared and purified by frequent recrystallization.

It is proposed to pursue farther the study of these double compounds of lead in the laboratory here.
Chem. Laboratory, U. N. C.

SOLUBILITY OF ALUMINA IN SULPHURIC ACID.

R. G. GRISSOM.

Ordinary commercial alumina is not very easily acted on by sulphuric acid, and this solubility varies very decidedly with the strength of the acid. The following experiments were undertaken to determine at what concentration the acid has the most powerful solvent action.

The sulphuric acid used contained 95.25 per ct. H₂ SO₄. Ten grams of alumina were put in a 200 c. c. flask, and the mixture of sulphuric acid and water (cold) poured upon it. A series of such flasks were heated to 30° for one hour. The contents were then largely diluted and filtered as rapidly as possible into 1000 c. c. flasks. The alumina was then determined in duplicate, using 25 c. c. for each determination.

| No. | C. C. H ₂ SO ₄ | v. C. H ₂ O | Ratio H ₂ SO ₄ to H ₂ O | Dissolved Al ₂ O ₃ 30° c | Dissolved Al ₂ O ₃ 100° c. |
|-----|---|---------------------------|---|---|---|
| 1 | 5.4 | 0 | 20:1 | 1.6100 | 3.9300 |
| 2 | 5.4 | 1 | 4:1 | 1.2400 | |
| 3 | 5.4 | 2.3 | 2:1 | 1.6000 | |
| 4 | 5.4 | 4.9 | 1:1 | 2.7600 | 5.2800 |
| 5 | 5.4 | 10.0 | 1:2 | 3.1200 | |
| 6 | 5.4 | 15.1 | 1:3 | 3.1800 | 5.8400 |
| 7 | 5.4 | 20.3 | 1:4 | 3.2000 | |
| 8 | 5.4 | 25.4 | 1:5 | 3.2400 | 6.0600 |
| 9 | 10.8 | 61.1 | 1:6 | 3.5200 | |
| 10 | 10.8 | 81.7 | 1:8 | 3.2400 | |
| 11 | 10.8 | 102.3 | 1:10 | 2.6900 | 5.5200 |

In the last column Nos. 1, 4, 6, 8 and 11, only were repeated and in the first four cases 10.8 c. c. acid were used, as this amount suited better the weight of alumina taken and the size of the flask. These experiments of course do not determined the absolute solubility of alumina in sulphuric acid. The temperature and length of exposure are both factors in the solution. They serve to show soley to what extent it is advisable to dilute the acid in order to bring about the greatest solvent action. The best ratio of dilution seems to be 1:5 or 1:6.

Chem. Laboratory, U. N. C.

ANALYSIS OF WATER FROM THE ARTESIAN WELL AT
DURHAM, N. C.

As this is the only deep artesian well in this State, it seemed of interest to have an analysis of the mineral matter held in solution by its water. A carefully drawn sample of this water was therefore analized. The sample was drawn during the summer of 1885, about five gallons being sealed in a new and clean demijohn and sent to this laboratory, under the direction of Mr. J. S. Carr.

The analysis resulted as follows :

| | | |
|-------------------------------------|--------|----------|
| In one kilogram of the water, | | |
| K ₂ O | .00817 | grammes. |
| Na ₂ O | .02352 | " |
| Ca O | .06160 | " |
| Mg O | .01717 | " |
| Fe O | .02400 | " |
| SO ₃ | .00446 | " |
| Cl | .03412 | " |
| Si O ₂ | .06200 | " |
| Total solids | .2240 | " |
| Or expressed in grains per gallons. | | |
| Potassium chloride | 29 | grains. |
| Sodium chloride | 3.84 | |
| Sodium sulphate | .42 | |
| Ferrous bicarbonate, | 31 | |
| Calcium bicarbonate | 11.43 | |
| Magn sium bicarbonate | 3.65 | |
| Total solids by evaporation, | 18.86 | |

This well is drilled through the older Mesozoic rocks. According to Mr. O. R. Smith, who had charge of the work, the drilling was stopped at 1,650 feet without reaching overflowing water. The cutting was mainly through sandstone, and at different depths brine and traces of oil and gas were

struck. A sixty pound charge of dynamite was exploded in the hope of increasing the supply of water and by this the well was blocked up to within 528 feet of the surface. Attempts at drilling through these obstructions failed, and the explosion of an additional ten pound charge of dynamite brought about no good results. An iron casing was therefore let down to this depth, and the water analyzed was pumped from the 528 feet well.

F. P. VENABLE.

Chem. Laboratory, U. N. C.

THE FERTILIZER TRADE IN NORTH CAROLINA IN 1886.

W. B. PHILLIPS.

About 100,000 tons of Commercial Fertilizers are used in North Carolina annually, sold by 58 companies under 90 brands. Each brand pays an annual license tax of \$500.00. Since the establishment of the Agric. Dept. in 1877, and the inauguration of the fertilizer control by the Agric. Expt. and Fert. Control Station, the number of brands and consumption of Commercial Fertilizers has shown a marked increase.

Brands of Fertilizers entered and amounts consumed from 1879 to 1886, inclusive :

| | Brands. | Consumption. short tons. |
|-------|---------|-----------------------------|
| 1879. | 42 | 60,000 |
| 1880. | 48 | 80,000 |
| 1881. | 58 | 85,000 |
| 1882. | 86 | 92,000 |
| 1883. | 92 | 95,000 |
| 1884. | 80 | 95,000 |
| 1885. | 83 | 95,000—100,000 |
| 1886. | 90 | 95,000—100,000 |

Each brand is subject to analysis at the Expt. Station, and the figures allowed for available Phosphoric Acid.

(Soluble and Reverted.) Ammonia and Potash at the sea-board are as follows :

| | Cents per pound. |
|----------------------------|------------------|
| Available Phosphoric Acid, | 7½ |
| Ammonia, | 16 |
| Potash, (K ₂ O) | 5 |

Accepting these figures agreed upon by the State Chemists of North and South Carolina, Georgia and Alabama,

the following table will show the commercial valuation of the *ammoniated super-phosphates with potash* ("complete fertilizer") from 1880 to 1886, inclusive, as given in the 1886 report of the N. C. Expt. Station, page 21.

| | 1880 per ct. | 1882 per ct. | 1883 per ct. | 1884 per ct. | 1885 per ct. | 1886 per ct. |
|---------------------------------|-----------------|-----------------|-----------------|-----------------|-----------------|-----------------|
| Available Phos. Acid..... | 7.40 | 8.91 | 8.59 | 8.15 | 9.13 | 8.96 |
| Ammonia..... | 2.70 | 2.60 | 2.33 | 2.67 | 2.65 | 2.53 |
| Potash..... | 1.30 | 1.82 | .218 | 2.13 | 2.34 | 2.30 |
| Valuation on 1886 basis.. . . . | \$21.04 | \$23.51 | \$22.53 | \$22.90 | \$24.52 | \$23.44 |

The following table will show where the brands used in North Carolina are manufactured, (Rep. N. C. Expt Station, 1886, p. 21).

| | 1880 | 1881 | 1882 | 1883 | 1884 | 1885 | 1886 |
|-----------------------|------|------|------|------|------|------|------|
| Massachusetts..... | 2 | 3 | — | 2 | 2 | 3 | 1 |
| Connecticut..... | 1 | 2 | 2 | 4 | 3 | 3 | 1 |
| New York..... | 3 | 6 | 5 | 3 | 2 | 4 | 3 |
| New Jersey..... | 3 | 3 | 1 | 1 | 1 | 2 | 8 |
| Delaware..... | 2 | 2 | 2 | 2 | 2 | 4 | 4 |
| Maryland..... | 21 | 25 | 45 | 42 | 30 | 31 | 35 |
| Pennsylvania..... | — | — | 1 | 1 | — | — | 1 |
| Virginia..... | 7 | 9 | 15 | 17 | 20 | 18 | 21 |
| North Carolina... . . | 3 | 3 | 6 | 6 | 8 | 9 | 10 |
| South Carolina..... | 5 | 6 | 9 | 14 | 12 | 11 | 11 |
| Total | 57 | 59 | 86 | 92 | 80 | 85 | 90 |

The following table shows the amounts of Kainit, Guano, Phosphate and Phosphate Rock received at the Port of Wilmington, N. C., from January 1st to December 31st, of each year.

| Year. | Imported from | Kainit. | | Guano. | | Phosphate. | | Phosphate Rock. | |
|-------|---------------|---------|----------|--------|---------|------------|---------|------------------------|-------|
| | | Tons | Value | Tons | Value | Tons | Value | Tons | Value |
| 1877 | Germany ... | 1,200 | \$10,548 | | \$ | | \$ | | \$ |
| 1878 | Germany ... | 300 | 2,098 | | | | | | |
| 1879 | Germany ... | 1,257 | 9,262 | | | | | | |
| 1880 | Germany ... | 3,068 | 14,894 | | | | | | |
| 1880 | Nova Scotia | | | | | | | 600 | 615 |
| 1881 | Germany ... | 3,334 | 23,696 | | | | | } Rock Plaster | 564 |
| 1882 | Germany ... | 6,867 | 43,219 | | | | | | |
| 1882 | England ... | | | 325 | 18,414 | 400 | 7,283 | 500 | |
| 1883 | Germany ... | 8,220 | 54,619 | | | | | | |
| 1884 | Germany ... | 13,348 | 82,503 | | | | | | |
| 1884 | England ... | | | | | 950 | 23,809 | | |
| 1885 | Germany ... | 9,084 | 62,851 | | | | | | |
| 1885 | England ... | | | 980 | 10,760 | 1,200 | 15,113 | | |
| 1886 | England ... | | | 76 | 2,493 | 745 | 8,752 | | |
| 1886 | France ... | | | 855 | 48,178 | | | | |
| 1886 | Germany ... | 13,042 | 91,776 | | | | | | |
| | Total | 59720 | \$395566 | 2236 | \$83844 | 3295 | \$54957 | 600 | \$615 |
| | | | | | | | | Rock Plaster 550 | \$564 |

In addition there is brought into Wilmington from outside the United States, about 5,000 tons of Navassa Phosphate Rock annually, costing, f. o. b., about \$7.00, from the Navassa Island, West Indies, all of which is consumed by the Navassa Guano Company of Wilmington. One cargo of 500 tons Roncador Island Phosphate Rock was brought into Wilmington in February 1885, but the venture was not successful, and no more has been brought.

Production of Fertilizers in North Carolina in 1886.

| Company. | Location. | Product | | |
|-----------------------|----------------------|------------------|---------------------------|----------------------|
| | | Guano short tons | A'd Phosphate short tons. | Gr'd Rock short tons |
| Navassa Guano... | Wilmington,..... | 6000 | 10000 | |
| Acme Manufacturing | Wilmington - Cronly | 2152 | | |
| Goldsboro Oil..... | Goldsboro | 2250 | | |
| N. C. Phosphate | Raleigh..... | | | est'd 500 |
| French Bro.'s .. | Rocky Point..... | | | 900 |
| Enterprise Fertilizer | Tarboro, estimated.. | 1000 | | |
| Durham Fertilizer.. | | 1000 | | |
| Total..... | | 12402 | 10000 | 1400 |

ELISHA MITCHELL SCIENTIFIC SOCIETY. 61

The value of these products can not be stated exactly, but will be very nearly given by the following figures:

Value of fertilizers produced in North Carolina in 1886.

| | | | |
|----------------------------|---|-----------------------|-------------|
| 12,402 tons Guano | - | \$23.00 | \$285,246 |
| 10,000 tons Acid Phosphate | | 14.00 | 140,000 |
| 1,400 tons Ground Rock | | 9.00 | 12,600 |
| <hr/> | | | |
| 23,802 | " | Fertilizers valued at | - \$437,846 |

It must, however be noted here that some of the companies buy acid Phosphate of North Carolina make, mix it with cotton-seed meal or other ammoniate and sell it as Guano. It is difficult to say exactly how much acid phosphate is thus counted twice, first as acid phosphate, the company selling it as such, and then by the purchaser as Guano after it has been dry mixed with some ammoniate. But there is reason for believing that this would not exceed 1,500 tons of the acid phosphate, corresponding to about 2,500 tons guano. A fair allowance would be 1,500 tons to be subtracted from the guano out-put. The preceding table would then stand corrected as follows :

| | | | |
|------------------------------------|---|---------|-----------|
| 12,402 tons Guano less 1,500 tons— | | | |
| 10,902 tons Guano at | - | \$23.00 | \$250,746 |
| 10,000 tons Acid Phosphate at | | 14.00 | 140,000 |
| 1,400 tons Ground Rock at | | 9.00 | 12,000 |
| <hr/> | | | |
| 22,000 tons fertilizers valued at | | | \$403,346 |

The 1,400 tons Ground Rock is not counted twice as it is North Carolina Phosphate Rock, Phosphate Conglomerate, etc., raised in the State, and sold as "fine ground" without being acidulated or ammoniated.

By reference to the table of production it will be seen that two companies make a speciality of "fine ground" Rock, French Bros at Rocky Point, Pender county, and the North Carolina Phosphate Company at Raleigh.

French Bros. have been in the business for several years, mining and grinding their own rock from contiguous deposits. The rock is a phosphatic conglomerate, a mass of phosphatic pebbles and nodules in a cement of carbonate of lime. It is burnt in kilns, screened, and the residue ground. This residue may contain :

| | | |
|----------------------------|-----|-----------------|
| Phosphate of Lime | - - | 20.34 per cent. |
| Lime, as oxide and hydrate | | 37.52 per cent. |

(For further information as to this see under "General Observations.")

Owing to insufficient machinery this company has not been able to place as much of their product on the market as they expect to do before long. The ground rock has a good reputation as a fertilizer.

The North Carolina Phosphate Company at Raleigh uses this rock also, obtaining it from Castle Hayne near Rocky Point. They have a very complete mill, with a Foster crusher, and two Frisbee-Lucop grinders, and are doing an increasing business, with a daily capacity of thirty tons.

Besides these two companies there are none that use North Carolina rock.

NAVASSA GUANO CO., WILMINGTON, N. C.;

works at Meares Bluff, Cape Fear river, five miles above Wilmington, established in 1869, and do the largest business of any company manufacturing in North Carolina. They use 11,000 tons of crude rock per annum, of which 5,000 tons is Navassa and 6,000 tons South Carolina Rock. Their daily capacity is

| | | | | |
|----------------|---|---|---|-----------|
| Ground Rock | - | - | - | 33 tons |
| Acid Phosphate | - | - | - | 70 tons |
| Guano | - | - | - | 75 tons |
| | | | | 178 tons. |
| Total | | | | |

Of their total production of 16,000 tons, they sell in North Carolina 10,000 tons. They make their own acid from Sicily Sulphur, and are well equipped and well situated.

ACME MANUFACTURING CO., WILMINGTON, N. C.

works at Cronly, on Carolina Central Railway, 17 miles from Wilmington. The year ending December 1, 1886, is really their first year in the business, as they were experimenting and getting ready. They use South Carolina rock, and have a daily capacity of

| | | | |
|----------------|---|---|-----------|
| Ground Rock, | - | - | 15 tons. |
| Acid Phosphate | - | - | 30 tons. |
| Guano | - | - | 60 tons. |
| | | | 105 tons. |
| Total | | | |

They make their own acid from Sicily Sulphur, and are well equipped, though not very well situated. They sell nearly all their product in North Carolina.

The Goldsboro Oil Co., the Enterprise Fertilizer Co.,

(Tarboro), and the Durham Fertilizer Co., buy Acid Phosphate, and 'dry-mix' their own Guano.

THE PRESENT OUTLOOK IN NORTH CAROLINA.

Opinions vary. Some think the prospect fair, others are inclined to take rather despondent views.

Fertilizers have declined in price, and the \$500 tax is not popular. There has been little or no mining of the regular North Carolina Phosphate Rock (containing 20-22 per cent. Phosphoric acid), for the reason that it lies in 'pockets' somewhat widely separated, and the topography of the region is unfavorable for cheap mining. As long as Charleston, S. C. Rock guaranteed to run 55 per cent. Bone Phosphate (25, 19 per cent. Phosphoric acid) can be bought f. o. b. for \$5.50 to \$6.50, there is but little prospect of the North Carolina Rock coming into market in any quantity.

The first systematic investigation of this Rock was made by W. B. Phillips in September, 1883, at the request of the Navassa Guano Company. In his report to that company, published in pamphlet form ("North Carolina Phosphates October, 1883") he took the ground that the steepness of the slopes on the sides of most of the little streams where the rock occurs would necessitate an excessive amount of digging, with proportional increase of expense, which the low grade of the rock would not repay. In March 1884, appeared the Report of the Experiment Station on North Carolina Phosphates, and since that time numerous references have been made to the matter in the publications of the Station, and of the Agricultural Department.

While the rock makes an excellent quality of acid Phosphate it remains to be seen whether it can compete with Charleston Rock. So far it has not competed, for the reason that none of it has been offered. As to how soon, if at all, it will be offered, is a very obscure question, and one which time, and it may be a good deal of it, alone can answer. As to the other raw materials for the manufacture of fertilizers, viz: *fish-scrap* and *cotton seed meal* as nitrogenous matter, *pyrites* as source of sulphuric acid, and *bones*, the following may be said:

FISH, OIL, AND SCRAP MILLS.

There are seven (7) in the State, three (3) of fair capacity, and four (4) small. Employment is given from April to November, to about 400 men, and the yearly value of the oil and scrap is about \$150,000.

The amount of North Carolina fish-scrap bought by the Navassa Guano Company in two years, ending February 5, 1885, was about 3,500 bags (140 tons), and they buy most of the scrap made in the State. This will give 1,700 bags (75 tons) per annum, which is perhaps rather less than the real production. The true figures will fall not far short of 100 tons. Good scrap should yield 10 per cent. ammonia on 10 per cent. water. The account will stand.

One hundred tons fish scrap 10 per cent., a \$2.50 per unit, \$2500. About one-third ($\frac{1}{3}$) of this is made at the mouth of the Cape Fear River, and the other two-thirds on Pamlico Sound, around Beaufort. The industry might be greatly enlarged, as there is always a good market for the scrap.

COTTON SEED OIL MILLS

There are nine in the State, with a total capacity in seed of 200 tons daily. A ton (2000 lbs.) of seed should yield 800 pounds of cake. The cake is worth \$2.50 per unit of Ammonia, and should run 8.5 per cent.

It is not known what proportion of the cake made goes into fertilizers, probably not above 4,000 tons. The product of two average size mills (the Acme and Goldsboro) is almost entirely used in this way.

PYRITES.

None mined for sulphuric acid. All the acid used in the manufacture of the fertilizers is made from Sicily Sulphur.

BONES.

Bones are collected, but only in a small way. There is at Salem a small mill for grinding bones, and the Navassa Guano Company buys them from local dealers in small lots. The total quantity is hardly above 100 tons per annum, and so we have 100 tons Bones a \$10, \$1,000.

MARL.

The use of marl is local, and confined almost entirely to the Eastern part of the State. Very little, if any, is shipped by rail, each neighborhood using what is convenient, and easily transported by wagons. This is to be regretted, as the heavy clay soils of the middle part of the State would respond very readily to such an application.

GENERAL OBSERVATIONS.

The most marked feature of the fertilizer trade in North Carolina in 1886, was the increased demand for fine ground

phosphate rock. The new mill at Raleigh was built to supply this demand, and the steady growth of the sales is an indication of the esteem in which the product is held.

An analysis of the article made at the Experiment Station is as follows:

Analysis of Ground North Carolina Phosphate Rock :

| | | | | |
|-----------------------------|---|---|---|-----------------|
| ¹ Bone Phosphate | - | - | - | 11.16 per cent. |
| Carbonate of Lime | - | - | - | 64.26 per cent. |
| Magnesia | - | - | - | 0.81 per cent. |
| Potash | - | - | - | 0.40 per cent. |
| Water | - | - | - | 1.39 per cent. |

The fine ground rock offered by French Bros. is of a somewhat higher grade. An analysis of their best grade is as follows :

| | | | | |
|---------------------------------------|---|---|---|----------------|
| ² Phosphate of Lime | - | - | - | 20.34 per cent |
| Carbonate of Lime | - | - | - | — — |
| Lime as Oxide and Hydrate | - | - | - | 37.52 per cent |
| Oxides of Iron and aluminum, and loss | - | - | - | 5.65 per cent |

This analysis represents the composition of the residue from burning and screening.

The composition before burning and screening is as follows :

| | | | | |
|---------------------------------------|---|---|---|-----------------|
| ³ Phosphate of Lime | - | - | - | 16.42 per cent. |
| Carbonate of Lime | - | - | - | 54.71 per cent. |
| Lime as oxide and hydrate | - | - | - | — — |
| Oxides of Iron and Aluminum, and loss | - | - | - | 3.91 per cent. |

The burning and screening separates the phosphatic nodules from the cement of carbonate of lime and converts this last into lime oxide and hydrate. All three of these articles are growing in favor with the farmers. The utilization of raw ground rock in the preparation of home-made manures, is one of the reasons why the price of acid phosphate and guano has declined. Extra inducements in the shape of lower prices have now to be offered since the farmer has discovered that he can buy a good article for nearly 50 per cent. less than he has been accustomed to pay.

¹ Equivalent to Phosphoric acid 6.11 per cent.

² Equivalent to Phosphoric acid 9.31 per cent.

³ Equivalent to Phosphoric acid 7.52 per cent.

Total value of all fertilizing materials made in North Carolina in 1886.

| | | | |
|--------------------------------|---------|-----|-----------|
| 10,902 tons Guano at | \$23.00 | - - | \$250,746 |
| 10,000 tons acid phosphate at | 14.00 | - - | 140,000 |
| 1,400 tons Ground Rock at | 9.00 | - - | 12,600 |
| 100 tons Fish Scrap at | 25.00 | - - | 2,500 |
| 4,000 tons Cotton Seed Meal at | 22.00 | - - | 8,800 |
| 100 tons Bones at | 10.00 | - - | 1,000 |
| | | | <hr/> |
| Total value | | | \$494,846 |

W. B. PHILLIPS.

LIST OF EXCHANGES.

GERMANY.

Der Naturhistorische Verein in Bonn.
 Der Naturwissenschaftliche Verein in Magdeburg.
 Der Naturwissenschaftliche Verein in Bremen.
 Berliner Entomologischer Verein.
 Die Naturforschende Gesellschaft in Danzig.
 Der Naturwissenschaftliche Verein in Regensburg.
 Der Naturhistorische Verein in Augsburg.
 Die Senckenbergische Naturforschende Gesellschaft in Frankfurt.

SWITZERLAND.

Die Naturforschende Gesellschaft in Bern.
 La Societe Fribourgeoise des Sciences Naturelles Fribourg

FRANCE.

La Societe Linneenne, de Normandie.
 La Societe Linneenne, du Nord de la France, Amiens.

ITALY.

Societe Toscana di Scienze Naturali in Pisa.
 Regio Istituto Veneto di Scienze Letture ed Arti, Venice

RUSSIA.

La Societe Imperiale des Naturalistes, de Moscou.
 La Societe des Naturalistes de la Nouvelle Russie, Odessa.

MEXICO.

Sociedad Mexicana de Historia Natural.

GREAT BRITAIN AND IRELAND.

Yorkshire Geological and Polytechnic Society, Halifax England.

Dumfriesshire and Galloway Natural History Society Dumfries, Scotland.

Belfast Naturalists Field Club, Belfast, Ireland.

CANADA.

Royal Society of Canada, Ottawa.
Ottawa Field Naturalist's Club.
Canadian Institute, Toronto.
Nova Scotian Institute of Natural Science, Halifax.
Natural History Society, Montreal.
Connecticut Academy of Arts and Sciences, New Haven.
Academy of Natural Sciences, Davenport.
Kansas Academy of Sciences, Manhattan.
National Academy of Sciences, Washington.
Peabody Academy of Science, Salem.
Society of Natural History, Brookville.
Natural Science Association of Staten Island.
Science Association, Peoria.
Scientific Association, Meriden,
Natural History Society, Trenton.
Linnean Society, New York.
Academy of Science, St. Louis.
Washington Chemical Society.
Michigan Horticultural Society.
Illinois State Laboratory of Natural History.
Wagner Free Institute of Science, Philadelphia.
American Academy of Arts and Science.
Western American Scientist.
Leander McCormick Observatory, University of Virginia.
Smithsonian Institution, Washington.
Washburn College Laboratory of Natural History, Kansas.
United States Geological Survey
Johns Hopkins University.—Circulars.
Cornell University.—Bulletins.
University of California.—Agricultural Reports
Modern Language Notes.—Baltimore.
Boston Public Library.—Bulletins.
N. C. Medical Journal.
N. C. Board of Health.—Reports.
N. C. Department of Agriculture.—Bulletins.

UNITED STATES.

California Academy of Sciences, San Francisco.
New York Academy of Sciences, New York.
Academy of Natural Sciences, Philadelphia.
Elliott Society of Science and Arts, Charleston.
Society of Natural History, Cincinnati
Minnesota Academy of Natural Science, Minneapolis.

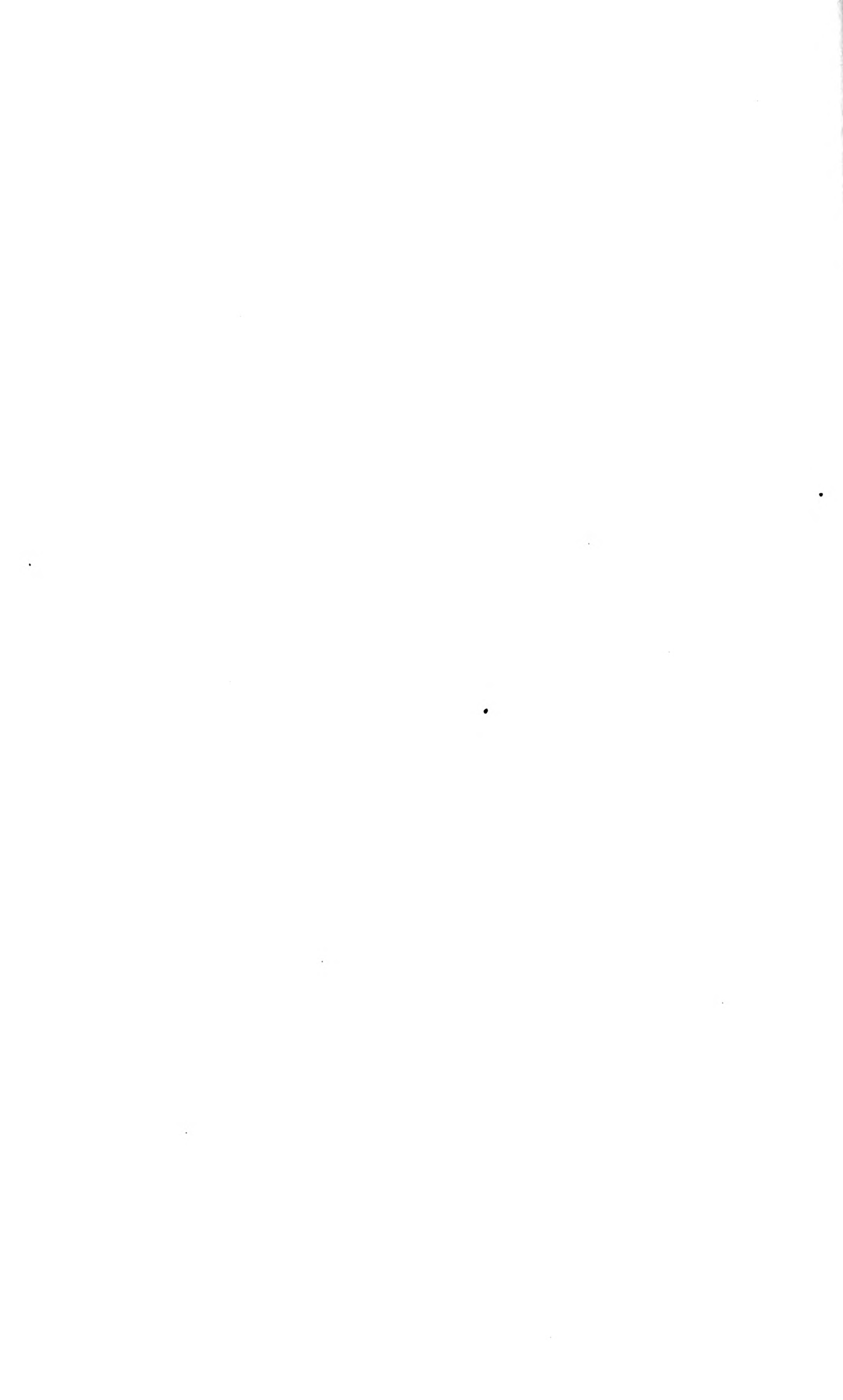



WASHINGTON CARUTHERS KERR.

JOURNAL

OF THE

ELISHA MITCHELL SCIENTIFIC SOCIETY,

VOLUME IV—PART II.

JULY—DECEMBER,

1887.

PUBLICATION COMMITTEE:

R. H. GRAVES,

J. A. HOLMES,

J. L. LOVE.

PERMANENT SECRETARY:

F. P. VENABLE,

- CHAPEL HILL, N. C.

E. M. UZZELL, STEAM PRINTER AND BINDER.

RALEIGH, N. C.

1887.

OFFICERS.

1887-1888.

PRESIDENT:

R. H. LEWIS, M. D., Raleigh, N. C.

VICE-PRESIDENT:

W. L. POTEAT, Wake Forest, N. C.

RESIDENT VICE-PRESIDENT:

W. B. PHILLIPS, PH. D., Chapel Hill, N. C.

PERMANENT SECRETARY AND TREASURER:

F. P. VENABLE, PH. D., F. C. S., Chapel Hill, N. C.

RECORDING SECRETARY AND LIBRARIAN:

J. W. GORE, C. E., Chapel Hill, N. C.

PUBLICATION COMMITTEE:

R. H. GRAVES, C. AND M. E., J. A. HOLMES, B. AGR.,
J. L. LOVE, B. A.

LIBRARY AND PLACE OF MEETING:

CHAPEL HILL, N. C.

TABLE OF CONTENTS.

| | PAGE. |
|---|-------|
| Biography of Dr. W. C. Kerr. By J. A. Holmes. | 1 |
| The Study of Local Floras. By Gerald McCarthy. | 25 |
| The Limits of the Senses. By F. P. Venable. | 31 |
| The Elements, Historically Considered. By F. P. Venable. | 36 |
| Effect of Decomposing Organic Matter on Insoluble Phosphate of Lime. By F. B. Daney. | 41 |
| Preliminary Catalogue of the Birds of North Carolina. By G. F. Atkin- son. | 44 |
| Singular Adaptation in Nest-making by an Ant. By G. F. Atkinson. | 88 |
| Remarkable Case of Phosphorescence in an Earth-worm. By G. F. Atkin- son. | 89 |
| Observations on the Female Form of <i>Phengodes laticollis</i> Horn. By G. F. Atkinson. | 92 |
| Analyses of North Carolina Wines. By F. P. Venable and W. B. Phil- lips. | 96 |
| Action of Chlorous Acid upon Heptylen. By R. G. Grissom. | 99 |
| A New Form of Bunsen Burner. By F. P. Venable. | 103 |
| A New Test for Iron. By F. P. Venable. | 105 |
| Electrolysis of Water. By F. B. Venable. | 105 |
| List of Papers Read at the Regular Meetings. | 107 |
| Public Lectures. | 108 |
| Use of the Library. | 108 |
| Publications Received since July, 1887. | 108 |
| An Index to the First Four Volumes. | 111 |

JOURNAL

OF THE

Elisha Mitchell Scientific Society.

A SKETCH OF PROFESSOR WASHINGTON CARUTHERS KERR, M. A., D. PH.

A LECTURE BEFORE THE MITCHELL SOCIETY, AT THE UNIVERSITY OF NORTH
CAROLINA, JANUARY 24, 1887, BY J. A. HOLMES.

Mr. President and Gentlemen:

The life and work of Professor Kerr is a theme which needs no introduction before members of this society. Probably but few of those here present knew him personally, but in one sense all knew him. He knew North Carolina better than the people of North Carolina knew him; and yet he was quite widely known, both at home and among scientific circles abroad. In traveling recently through some of the nooks and corners of this State I have been surprised at times to hear him spoken of where I least expected it; and I know that his fellow-geologists in this country have placed a high estimate on his character and on his scientific work.

We may be sure of this much at any rate: that wherever in the State there is located a mine of importance, or other valuable mineral deposit of any kind, a fine water-power, valuable tracts of timber land, or interesting geological formations—wherever there has been, during these past twenty years, a man who sought information concerning the natural resources and material prosperity of North Carolina—there Professor Kerr's

name is a familiar one, and there, especially, during the two years and more since his death, there has been a realization of the fact that the important place he occupied among the people of the State is now vacant.

Professor Kerr was in birth, in education (in part) and in his life work closely identified with this State; and, as far as I am aware, he is almost the only native-born North Carolinian who has at yet attained a position of eminence in the ranks of science. Of the few others belonging to these ranks who have worked in the State, Professors Olmsted and Mitchell were natives of Connecticut, Dr. Von Schweinitz of Pennsylvania, and Drs. Curtis and Emmons of Massachusetts.

Washington Caruthers Kerr was born in the Alamance region of Guilford county, N. C., May 24, 1827, and died in Asheville, August 9, 1885. His ancestors were among the sturdy Scotch-Irish families who came into this State from time to time about a century ago, and who have been important factors in the growth of several portions of North Carolina. His father, William M. Kerr, was a farmer of small means. His mother, Euphence B. Doak, was a woman of marked characteristics, and is said to have possessed a mechanical talent unusually well developed. They had six children, of whom the subject of the present sketch was the third. Both parents died early in life, leaving their young children with no fortune save such early training and education as they had been able to give them at home.

Young Washington Caruthers, thus early thrown upon his own resources, soon developed the qualities he exhibited so prominently throughout his whole career—energy, perseverance, decision of character, a thirst for knowledge, and deep piety.

After the death of his parents he was taken in charge by the Rev. Dr. Caruthers, a Presbyterian minister, author of "Revolutionary Incidents" in North Carolina, and widely and favorably known in the State for his piety and learning.

Dr. Caruthers had been long the pastor and friend of the Kerr family, and the boy he thus adopted had been named in his honor. In addition to his labors as a minister he conducted

a school at or near Greensboro, where he lived, and largely under his instruction young Kerr was prepared to enter the University—which he did in 1847, as a sophomore. He was graduated in 1850, taking highest honors in his class.

I cannot dwell long upon Professor Kerr's University life, though, in some respects, no part of his career is more deserving of consideration. It does not appear that he exhibited at this time any special tendencies in the direction of his later professional work, but we must remember that in 1847, chemistry, geology and natural history were all taught from text-books, in the class-room, by one man, who performed other duties besides. There was then no bringing the student face to face with nature; no inducement, no opportunity for original investigation by the student; no awakening of interest in such work. But in general scholarship in the University and in the debates of his literary society he was without a superior among his classmates. He was a hard-working, careful student, full of energy and ambition, and always ready with speech and pen.

His University life was not, however, in every respect a pleasant one. It was a struggle against poverty, and he was proud and sensitive. Here again, however, the necessary aid was at hand; the University made no charge for his tuition, and the Dialectic Society, of which he was a member, made him its beneficiary, and paid all necessary living expenses during his connection with the institution. Some years after graduation he returned to the University and brought his wife with him, and showing her the places familiar to him as a student, he took her to a certain spot on a street in Chapel Hill, and told her how once Dr. Mitchell (then the Bursar) approached him there and reminded him of some small payment due the University. "The Doctor went on," he said, "and there I stood, and where under all God's sky I could raise five dollars I did not know. The agony and humiliation were too great, and I resolved to quit college and give up all hope of an education."

Fortunately for us, and for himself, he did not go, but such an experience he never forgot. To help other people in like

straits, was in after life one of the ways in which he expressed his remembrance. And nearly thirty years after his graduation, when the University was in need of funds, and its friends were asked to contribute money for the repairs of the buildings, Professor Kerr was one of the few who remembered how much it had done for him, and contributed largely for a man of his limited means. And I may here mention another incident in the history of his University life which illustrates the rigid honesty of the man. The sum granted annually by the Dialectic Society for the support of its beneficiaries, just enough to supply the necessaries of life, was always given and accepted as a free and willing gift. Young Kerr found that by cutting his wood and attending to his fires himself, and by practicing economy in other ways, he could live on less than the amount set apart for his support, and returned the surplus to the Society. The only case of the kind on record, so far as I am aware.

During the first year after his graduation, young Kerr taught school at Williamston, Martin county, N. C. Shortly after this he was elected to a professorship in Marshall University, Texas, which he accepted; but after a brief stay there he resigned his position to accept an appointment (1852) as computer in the office of the Nautical Almanac, then located in Cambridge, Mass. Prof. Kerr's connection with the Nautical Almanac (from June, 1852, to January, 1857), and his consequent life at Cambridge, marks an important period in his life. On the Almanac he was principally employed in making astronomical computations, computing the moon's right ascension and declination, its culmination over the meridian at Washington, and the lunar distances; he also computed the eclipses for the year 1857.

But this work on the Nautical Almanac, though Professor Kerr's source of support (and yielding him an income more than sufficient for this), was by no means the most important feature of his life in Cambridge. Here, for the first time, he was in an atmosphere of active scientific work. Here he met, as instructors or associates, Agassiz, Pierce, Davis, Lovering, Horsford, Eustis, Guyot, and many others. Here he begun his own work

in science. Here he made acquaintances and formed friendships that yielded pleasure, encouragement and assistance during the remainder of his life. During the earlier part of his stay here (1853) he was happily married to Miss Emma Hall, of Iredell county, N. C.

The work on the Nautical Almanac did not require all of his time, and during the years 1853-'4 and 1854-'5 he is recorded as a member of the Lawrence Scientific School, studying geology, mathematics and engineering. During this time (1853-'56) he also studied zoology under Professor Agassiz, botany under Professor Gray, and chemistry under Professor Horsford.

These years at Cambridge were among the happiest of Professor Kerr's life. In after years his face always brightened when he referred to them. Naturally enough, Agassiz was the central figure among those whom he admired and under whom he worked. He often alluded to his first lesson in geology—Agassiz's giving him a handful of sand and asking him to report on its contents—and other incidents connected with his great teacher. He was just beginning, under Agassiz, a piece of original research in connection with some newly-discovered species of fossil fishes, which was interrupted by his being offered, and accepting, in February, 1856, the professorship of chemistry and geology at Davidson College, in this State. However, he remained at Cambridge a year after this, continuing his connection with the Nautical Almanac (until January 13, 1857), and during his spare time preparing himself more fully for his future work at Davidson College, where he begun the duties of his professorship early in the year 1857.

In speaking of Professor Kerr's work at Davidson, I cannot do better than quote from a letter on this subject written by a gentleman who was one of his students at the college during 1858 and '59, and whose name would be a sufficient guarantee of the accuracy of his statements. He says of Professor Kerr: "He was an ardent student, an enthusiastic and successful teacher, and it seemed almost by contagion his students would catch something of his spirit. He had little patience with dull-

ness—none with idleness—and his class-room was dreaded by the indolent or careless. It was the delight of others. He was a successful experimenter, and every operation in chemistry was beautifully illustrated, with the imperfect appliances at his command. He taught by text-books, with explanatory and supplemental lectures. He was always adding to the museum, and gathering about him specimens, maps and sections to illustrate his teaching in geology and mineralogy. We used to call him ‘Steam Engine,’ instead of Kerr, such was his promptness to time and rapid motion.”

Another of his students of 1857 and '58, whose statement may be relied upon, says: “Professor Kerr brought new life to the college, and was the most industrious teacher I have ever known. He awakened thought and investigation. My class never did so hard work for any other teacher.” He occasionally took his students on field excursions in geology. During the summer months of 1861 he led a party of them through a considerable portion of the mountain region of North Carolina, making extensive geological and topographical observations.

Professor Kerr's connection with Davidson College continued from 1856 to July, 1865 (the date of his resignation), but his active work there ceased three years prior to this latter date. Soon after the beginning of the civil war there was a falling off in the income of the college and in the number of students. Professor Kerr requested, and was granted (July, 1862), a leave of absence until such time as he was needed, and in the latter part of 1862 he became chemist and superintendent to the Mecklenburg Salt Company, whose works were located at Mt. Pleasant, near Charleston, S. C.

This position he continued to hold until April, 1864, when the works were destroyed or abandoned. The company worked profitably during its short existence, and Professor Kerr's services were highly commended. While engaged in the work he introduced several improvements in the process of manufacture of salt, chiefly in the construction of better chimneys, which operated a larger number of salt-pans; in placing

the pans in positions better suited to more extensive work with less handling, and in the pumping apparatus for transferring the brine from one pan to another. These improvements were so effective that their introduction reduced the cost for wood one-half, and also greatly lessened other necessary expenses.

After the destruction of the salt works Professor Kerr returned to North Carolina and was appointed State Geologist of North Carolina by Governor Vance in 1864. This office he held—quoting his own words—“during the last year of the war, *nominally, and without pay, and with special instructions* to look after certain chemical and mineral manufactures in which the people of the State were vitally interested.” Under circumstances like these there was, of course, neither time nor money for the ordinary work of a geological survey, and the time of the *nominal* State Geologist was fully occupied in advising and directing in connection with the manufacture of salt, saltpeter, copperas, sulphur, sulphuric acid, medicinal extracts from plants, and various other substances needed for purposes of war or home consumption. And subsequent to this came the closing scenes of the war, when all was confusion and disorganization, and even the nominal geological survey disappeared from view until April, 1866, when it was revived and Professor Kerr re-appointed State Geologist by Governor Worth.

The work with which the name of Professor Kerr is to be permanently associated is that done in connection with the Geological Survey of North Carolina. He began this work in his mature manhood, and devoted to it the best years of his life. His more important scientific work was done during this time, and as far as these are known to me, all his scientific papers were published during his connection with the survey. From the time of his appointment as State Geologist (April, 1866), he continued his connection with the survey without interruption until August, 1882, when he resigned to accept the position of geologist on the United States Geological Survey. And when declining health compelled him (in September, 1883) to resign this latter position, he returned to North Carolina, and, in part,

renewed his connection with the State Survey, hoping that he might be able to complete certain unfinished work. But the end came and found his hope unrealized.

In endeavoring to understand clearly the character and extent of the work undertaken by Professor Kerr in the organization and prosecution of his survey, it will be well for us to review briefly the work done and that left undone by his predecessors. As to the survey by Professors Olmsted and Mitchell (1824-'28), at so late a date as 1866, it was of interest mainly from an historical stand-point, as being the first geological survey undertaken by any one of the States. It located a few of the valuable mineral deposits and approximately some of the geological formations, but as a scientific survey it could hardly be considered more than a preliminary geological *reconnaissance*. After the close of this survey (1828), Professor Mitchell continued for several years to make explorations in different portions of the State at his own expense, and the general results he published in 1842 in a small volume* accompanied by a geological map of the State. This geological map of the State was the first published, and none other appeared until 1875. It reflected credit upon its author, but was not found sufficiently accurate in detail to be of any great value, in the work of the survey under Professor Kerr.

Dr. Emmons, while State Geologist (1851-'63), did a large amount of valuable work, especially in connection with the geology and agriculture (including the swamp lands) of the eastern region, and the geology, mining and agriculture of the middle region; and he made several geological excursions into the western portion of the State. At the breaking out of the civil war, he had nearly completed a geological map of the State, a map of the coal fields, manuscript reports on the agriculture of the middle section, and a partial report on the general resources of the western section of the State. But in the tur-

* Elements of Geology, with an Outline of the Geology of North Carolina: for the use of the students of the University. By Elisha Mitchell, Professor of Chemistry, Mineralogy and Geology, in the University of North Carolina. 1842, 12 mo., 141 pp., with a geological map of the State.

moil and excitement of the war all of these, together with all the manuscript and field notes of the survey, were lost or destroyed, and the industrial enterprises inaugurated or stimulated by the ten years' existence of the survey were checked or permanently suspended.

As the tangible results, then, of the Emmons survey, we have his five published reports relating to the geology and agriculture of the eastern section (including the swamp lands), and the geology and mining of the "Midland Counties" as far west as the Catawba river—these and, practically, nothing more.

Organized under the same law, Professor Kerr's survey had in view the same general purposes as the Emmons survey which had preceded it, viz., investigations into the general geology and natural history and the natural resources of the State. Such being the case, it was Professor Kerr's plan to determine what of the objects had been most fully accomplished during the administration of Dr. Emmons, and as far as possible to avoid unnecessary repetition in supplementing the work already done. But he found that in a study of the general geology of the State, and in making a new geological map, it was necessary to go over the entire State again. In the eastern region much still remained to be done in determining the relative age of the deposits, and in the middle and western regions, with the improved methods of lithological study, it was found necessary to have the rocks of both regions carefully examined.

But before this work in general geology and the making of a reliable geological map could be successfully prosecuted, it was necessary that the survey be in possession of a topographical map of greater accuracy than was then to be had; and for several years no small part of Professor Kerr's time was necessarily given up to this topographical work. In connection with this work he found it necessary to determine the elevation, latitude and longitude of quite a number of places in the middle and western regions of the State—his work in this direction supplementing that done by Professor Guyot and the United States Coast and Geodetic Survey.

Also in the departments of mining and paleontology much remained to be done. In connection with the departments of agriculture it was necessary to make arrangements for the analyses of numerous soils and marls; in meteorology, stations were to be organized in many parts of the State, and each supplied with instruments, for the purpose of determining, as far as possible, the climatology of the State. Indeed, but two branches of the survey, viz., zoology and botany, had been worked up (and these by Dr. Curtis) with a thoroughness that could be considered sufficient for existing purposes.

The new features undertaken by Professor Kerr in connection with the survey were the investigation into the topography, the climatology, water-power, mineralogy and lithology. Of work already undertaken by Professor Emmons he endeavored to continue that relating to agriculture, ore deposits, general geology and paleontology.

When it is remembered that all the work outlined above was to be undertaken with an appropriation of "not more than five thousand dollars per annum," it will be understood that the survey must necessarily have been organized on an economical basis, and the work prosecuted at a disadvantage. And such indeed was the case.

When in 1866, Professor Kerr was appointed State Geologist, he did not bring to the work of the survey an extended professional experience; nor may we consider him at that time in any high degree a trained specialist. He at once, however, devoted himself to the task of organizing the work of the survey, in all its departments, and in accordance with the terms of the law and the interests of the State. He associated with himself such specialists as Cope, Conrad, Genth, Julien and others, and placed in their hands for examination the collections belonging to their respective departments.

So great was the variety of work the survey was authorized to undertake that, with the small appropriation at its disposal, it was often necessary that the Geologist should undertake in person investigations of a widely different character. This was

especially the case in connection with the topographical work of the survey. There was in 1866 no even approximately accurate map of the western part of the State upon which could be laid down the data for a geological map. During almost the entire period of the existence of the survey Professor Kerr, in making his geological excursions, combined topographical and geological work. And in this way he became quite proficient in the detection of geological structure as exhibited in the topography of the region.

In some cases his topographic observations were only approximate, taken with a pocket compass, pocket level, or aneroid barometer; but as a rule these instruments were used only to fill in details after the more important measurements had been taken by means of more accurate instruments. During several seasons, early in his connection with the survey, Professor Kerr devoted a considerable portion of his time to topographic work (or geological and topographical work combined) in the mountain region.

These numerous topographic observations, made by himself and his assistants, bore fruit in 1882, when he published the new State Map, to be used as a base for the geological map.

In connection with this work, he examined all the accessible records of the surveys of railroads, rivers, canals, State and county boundary lines, and of the United States Coast and Geodetic Survey, within the limits of the State; and combining the results of these examinations with those of his own and his assistants' work in the field, he produced a map which in point of accuracy is incomparably in advance of any map of the State that preceded it; and maps published subsequent to its date will be indebted to it more than they are wont to admit. Its preparation cost its author no small part of fifteen years of labor.

Professor Kerr was a rapid worker in the field, and at no time could this fact be observed to better advantage than during one of his horseback trips through the mountain region of the State, which he seemed to enjoy so much. After his appointment as

State Geologist he devoted himself first to these western counties, which had been more or less neglected by Dr. Emmons. He traveled, mainly in the saddle, 1,700 miles over mountain roads and mountains without roads, within less than four months; and in two seasons (parts of 1866 and 1867) traveled on horseback a distance of more than 4,000 miles.

It was during this rapid *reconnaissance* of the mountain region that he became acquainted with many of the problems which the structure and drainage of this region present. The drainage, especially, interested him, and he recognized what appears to be the true explanation of the origin of its prominent features, viz., the existence of the Blue Ridge as the original water-divide, from the crest of which, at approximately right angles to its course, flowed the accumulated waters of the larger streams; the subsequent slow and gradual elevation of the Smoky Mountains and the intervening plateau region on the west, through which the rivers eroded their valleys, *pari passu*, as the elevation progressed. The smaller streams tributary to these rivers as a rule have their general course at right angles to the latter, and parallel to the mountain range and to the outcrop of the more or less nearly vertical strata, into the upturned edges of the less durable layers, of which they have carved their channels. During these and subsequent years he collected a large amount of material with a view to writing a special report on the drainage and physical structure and history of this region; but the press of other duties, and later, declining health, prevented its preparation.

During his entire connection with the survey Professor Kerr spent a considerable portion of his time in field explorations. He traveled a good deal along the lines of railroads, on hand-cars or on foot, leaving the railroad at intervals to examine soils, rocks, mines, &c. At other times he traveled in a buggy or spring wagon, prepared especially for his purpose, or in hilly regions on horseback. In studying the geology of the eastern region of the State, along the water courses, he traveled by boat.

In one or the other of these ways he traversed in different directions every county in the State—some of them many times. Occasionally he delivered a lecture in the town through which he passed. Generally as he traveled he collected for the State Museum specimens of rocks, soils, minerals, ores, marls, woods, and other products. His field note-books are full of notes concerning especially the rocks, soils and forests of the regions through which he passed.

There were no permanent assistants employed on the survey, and in view of the limited appropriation at his disposal, Professor Kerr adopted the plan of doing in person the general work of the survey, and engaging the services of specialists or general assistants when these were needed. He attended to the official correspondence, without the aid of either clerk or amanuensis; and no one who has not occupied a somewhat similar position can realize the amount of labor and time this demanded.

His correspondence concerning the mineral, mining and other economic interests of the State was quite large, and with men in many parts of the United States and Europe. His correspondence with citizens of this State was large and covered almost every subject. In the same mail one might see the following assortment of letters, addressed to the State Geologist: One asking for instructions as to the best method of developing or selling a gold mine; another asking for similar information about a deposit of mica; another (or several) accompanying specimens of rocks, minerals or ores, asking for a complete analysis and instructions for development or selling the property; and perhaps a dozen others asking for information about the gold deposits, the water-power, and the climate of the State, the practicability of a railroad passing through this or that region, the improvement of worn-out lands, as to the best methods of raising silk-worms, making vinegar, medicine for a sick horse, and subjects not more germane.

In endeavoring to estimate the results of Professor Kerr's work we may confine our attention to the period of his connection with the survey, whether we have for consideration the material

benefits resulting to the people of the State, growing out of his work as State Geologist, or his contributions to science. The former of these cannot now be estimated with accuracy, but we may safely say that his work has been an important factor in the recent material growth of the State.

In connection with the mining interests, during the past twenty years, several millions of dollars have been brought into the State; and while exercising an important influence in connection with this, the survey has encouraged a more judicious investment of home capital, and has done an important work in preventing numerous investments where the undertaking would have proved a failure and the money invested lost.

The agricultural interests of the State received at all times Professor Kerr's earnest attention. He made numerous analyses of soils and marls, and he did all in his power to stimulate the improvement of worn-out soils by the use of marls, lime and other fertilizers, and by other methods. The inspection and analyses of commercial fertilizers, inaugurated and continued for several years by him, and later carried on by the Experiment Station, has proved of incalculable benefit to farmers in every portion of the State; and Professor Kerr, together with the honored President of this University and a few others, was instrumental in the establishment of the Department of Agriculture and the Agricultural Experiment Station. He inaugurated the movement of a few years ago looking to the increase in supply of food fishes in the streams of the State; and (as stated already) he established and kept in existence for a time a series of meteorological stations in different portions of the State. He originated the silk-raising movement in North Carolina—a result of his visit to the Vienna Exposition. He measured the water-power of all the important rivers of the State.

In the matter of advertising the State's resources by making collective exhibits at great expositions, Professor Kerr believed that much benefit would result to the State, and subsequent developments have proved that he was correct. In 1873, though the Legislature of the State declined to appropriate

money for the purpose, he, together with two or three other patriotic citizens, contributed of their own private funds sufficient to enable him to collect specimens illustrative of the State's resources, which he took to Vienna and exhibited at the International Exposition.

In connection with the Philadelphia Exposition of 1876, though the State again failed to make an appropriation for the purpose, Professor Kerr, out of the limited funds of the survey, made an exhibit of the building and ornamental stones of the State, which was commended for its excellence; and he remained at Philadelphia during much of the time of the Exposition as one of the judges. While there, under the direction of the Exposition authorities, he delivered an address on the history and resources of North Carolina, and did everything in his power, by way of distributing reports and circulars, and by personal interviews, to direct the attention of capitalists to the State. Subsequently he was the leading spirit in making the North Carolina exhibit at the Atlanta Exposition (1881), and his preliminary work made the fine exhibits at Boston (1882) and New Orleans (1884) practicable undertakings.

The distribution of Professor Kerr's reports, and his official correspondence with persons in our own and other countries, have been doubtless of great service in the development of the State's resources; not only in importing capital, but also in educating the people of the State, thereby giving them a more intelligent understanding of the nature, extent and worth of their properties.

The educational value of his work among the people of the State—accomplished through his reports, newspaper articles, correspondence, lectures, private talks, and the State Museum—has been of itself a matter of considerable importance.

Not least among his undertakings was the State Museum, at Raleigh. It was a part of his plan, from the time of his first connection with the survey, to bring together such series of specimens as would represent the general natural history and natural resources of the State. He used to say that he wanted

to "bring North Carolina together in one building," where she might be studied by specialists in science, or by persons looking to an investment in the State, and where the people of the State might go and become familiar with her native wealth—a plan full of promise; but, unfortunately Professor Kerr, had neither the time nor funds to enable him to carry it into full execution. He collected from all parts of the State a large amount of material, consisting mainly of specimens of rocks, minerals, fossils, soils, marls, agricultural products, woods, and others of miscellaneous character, but had not been able to arrange them fully up to the time when press of other work and declining health compelled him to give up all endeavor in this direction.

But it is impossible in a few statements to give an adequate conception of the extent and of the benefits, to the people of the State, of Professor Kerr's work—benefits that will continue to be felt during years to come. He begun his work at a time in the history of the State—just after the close of the civil war—when her industrial as well as her social condition was one of disorganization and suspension. It was his desire and aim to stimulate and encourage her material prosperity, and while favored with good health he gave himself up to this endeavor with a foresight, energy and devotion not often surpassed.

Among other results of general interest, it may be stated that Professor Kerr has left us a fairly good knowledge of the physical structure and climatology of North Carolina and has mapped the outlines of the geological formations of the State much more fully and accurately than had been done before. Could he have lived a few years longer he would have added materially to our knowledge in these directions. His scientific work was chiefly in physical geology, and though not extensive, it was sufficient to give him an enviable position among American geologists. Professor Dana says of him, in the *American Journal of Science* for 1885 (xxx, p, 248): "He was an excellent observer in geology, and in his few publications brought out results of great interest. He was the first in the country to call attention to, and rightly explain, the unequal steepness in the opposite banks

of streams, where flowing through yielding deposits (Rep. Geol. N. Carolina, Vol. I, p. 9*); and the first to appreciate adequately and describe the action of frost in producing the deep movement and bedded arrangement of loose material on slopes (Am. Jour. Sci., III, xxi, 1881, p. 345†), the depth in North Carolina being such as to indicate, in his view, the unusual conditions of a Glacial era." In 1881 (Am. Jour. Sci., III, xxi, p. 216) he suggested the glacial origin of certain topographical features of the hydrographic basins of rivers in the southern Appalachian region (North Carolina), but this does not appear to have met with general acceptance.

A full list of Professor Kerr's reports and more important scientific papers will be given in the bibliography, published in the Journal of the Society as an appendix to this sketch. Of his official reports, the two first were small reports of progress, published in 1867 and 1869, discussing mainly the general and economic geology of the part of the State west of the Catawba river—especially the mountain region. The first of these contained also (Chapter III) a short general discussion of the "Minerals of North Carolina," which was subsequently, in part or as a whole, several times republished by the State and private land agencies. A third small report was published in 1873, as an appendix to the report (Vol. I, 1875) then in press, which was an abstract of that report, intended for general and immediate distribution. This small report was subsequently revised and republished in 1879, under the title of a "Physiographical Description of North Carolina." The most important of his reports is that of 1875 (Geology of North Carolina, Vol. I), treating of the physical geography, general and economic geology of the State. This report was offered to the Legislature in 1870, but its appearance was delayed until 1875, the Legislature having failed to make an appropriation for its publication. It was Professor Kerr's plan to prepare a second volume (Vol. II of his Final Report), to contain a more full

*See also Trans. Am. Phil. Soc., xiii, 1873, p. 190.

†See also Trans. Am. Inst. Mining Engineer, viii, 1879, p. 462.

discussion of the general and economic geology of the State; and Chapter I of this volume, discussing the "Minerals and Mineral Localities of North Carolina," was published by him in 1881; but press of other duties at that time, his resignation in 1882, in order to undertake the topographical and geological work on the Appalachian division of the United States Geological Survey, and his subsequent decline in health, all combined to interrupt the completion of this report. So much of it as relates to the economic geology of the State is now being published under my own direction. Three additional small reports of the survey were published by the State as public documents, viz., a Report of Progress in 1873, a Report on the Expenditures of the Survey and a Report Concerning the Establishment of a State Department of Agriculture, in 1877. In 1882, Professor Kerr published his new Map of North Carolina.

He was appointed special agent of the Tenth United States Census to report on the cotton production and general agricultural features of Virginia and North Carolina; and his separate reports on these States were published in Volume VI of the Census Reports (1884). He was an occasional contributor to the scientific journals of this country, and his more valuable contributions are to be found in the *American Journal of Science*, and in the *Transaction of the American Institute of Mining Engineers*. He wrote the article on North Carolina in the *Encyclopædia Britannica* (9th Edition).

Professor Kerr was a member of several learned societies, including the American Institute of Mining Engineers, the American Philosophical Society of Philadelphia, and the Philosophical Society of Washington. He was also a Fellow of the American Association for the Advancement of Science. He was a member of, and during the years 1884-'85 was President of the Elisha Mitchell Scientific Society.

When in August, 1882, he was offered the position of geologist on the United States Geological Survey, he accepted the appointment in the hope that he might be able to carry into execution a long cherished plan of making a more systematic

and thorough study of the topography and geological structure of the Appalachian region. But in this disappointment awaited him. He had but fairly begun the topographic work when, in September, 1883, failing health necessitated his resignation.

The disease—catarrh of the digestive organs—which had for so long a time preyed upon him, had now greatly weakened his system. During the two years following he was unable to do any active work. He spent the winters at Tampa, Florida, and the summers in the mountain region of this State. It was during these stays at Tampa that he made observations on the eocene deposits there, his notes on which were published subsequent to his death, in the Journal of this Society (1885-'86).

Professor Kerr was through his whole life at the disadvantage ordinarily attendant on a physical organization too frail for the work imposed upon it. He was of the sturdy and enduring Scotch-Irish race, but there must have been a cross of some other blood which gave him the *verve* and delicacy of mind and body that distinguished him, and that even in early life indicated him as one not likely to see old age. For the last fifteen or twenty years the condition of his health was a constant source of anxiety to his friends and family. Still he would not succumb, but cling to his work, impelled and sustained by nervous energy alone, and undertaking additional labor even after it was plainly apparent that his day was over.

Many things depressed him, many things irritated and hindered, which, if his physique had but been coarser and stronger, he would not have felt. No memoir that means to do him full justice should omit to indicate these characteristics, since by them he was often judged and misjudged.

From the time of his appointment as State Geologist to the day of his death he spared himself no pains, no exertion, no fatigue in his ardor for the development of North Carolina, his anxiety to see her among the foremost in the new race set before the South. The State has never had a more genuinely and sagaciously public-spirited citizen than he. But the times were evil, and for several years Professor Kerr shared the fate of all

public officials who were endeavoring to adjust, to reconcile, and to go forward. His motives were misrepresented, his character assailed, his abilities questioned, his work maligned.

The effect of such an ordeal on a man of delicate nervous fibre and of refined feeling may easily be imagined; nor can it be wondered at that he was often impatient, often despondent, and often fairly unhinged by the obstacles set in his way. Almost every session of the State Legislature was a season of humiliation, and, as he himself expressed it, of "real torture" to him. At the adjournment he would draw a long breath of relief, and say the incipient paralysis had passed off and he could go to work again and feel like a gentleman once more.

In his own house, Professor Kerr's hospitality was unbounded. Scientific visitors would sometimes remain with him weeks at a time. He thought it his duty to entertain strangers, and every public occasion in Raleigh filled his house with guests. He was a most interesting companion, animated, receptive, sympathetic, taking a vivid delight in conversation, and as ready to listen as to talk.

His belief in the outcome that there was in this State, in the great future that lay before her people, was commensurate with his knowledge of her natural resources. He knew them well and rated them justly, and was never so enthusiastic, so vivid, so eloquent, as when dwelling on these advantages. In his death the State has met with an inestimable loss. In some respects he has lived ahead of his time. He was, in his own department of work, more widely and favorably known, and deservedly so, than any man the State has produced or the State University has graduated.

He was an exceedingly liberal man; a man of generous temper, and of large views not only, but open-handed to every call in State or Church, or private benevolence that his judgment approved. He was deeply religious, and always prominent, though in an unobtrusive way, in matters pertaining to his church. As a Christian gentleman, those who have known him best have admired him most. His heart was warm and gener-

ous, his mind was clear, active and progressive, his conscience keen and inflexible. He was honest in every sense of the word. There was nothing of policy in his thought or action. On the contrary, he was frank and outspoken, at times even to a fault.

He left his native State the better for his example and for the work that he did in her service. If he failed to do all he aspired to do, and was compelled to leave his task incomplete, it was no more than an oft accompanying condition to human endeavor weighted by human frailties.

BIBLIOGRAPHY.

The following is a list of Professor Kerr's more important published papers and reports:

*Report of the Progress of the Geological Survey in North Carolina, 1866; by Professor W. C. Kerr. Raleigh, 1867. 8 vo., 56 pp.

Report of the Progress of the Geological Survey of North Carolina (for 1866 and 1867). N. C. Ex. Doc. No. 27. Session 1868-'69. Raleigh, 1869. 8 vo., 57 pp. (W. C. Kerr, State Geologist).

Appendix to the Report of the Geological Survey of North Carolina, 1873, being a brief abstract of that report, and a general description of the State, geographical, climatic and agricultural. By W. C. Kerr, State Geologist. Raleigh, 1873. 8 vo., 24 pp. and map.

Topography as Affected by the Rotation of the Earth. By W. C. Kerr, State Geologist of North Carolina. Trans. Am. Phil. Soc., Vol. XIII, 1873, pp. 190-93.

Report of State Geologist on the Progress of the Survey. N. C. Pub. Doc., No. 16. Session 1872-'73, 14 pp. (W. C. Kerr).

*The concluding chapter (III) of this report on the "Minerals of North Carolina" was originally published by Professor Kerr (see page 44) in substantially the same form as here, just prior to his re-appointment as State Geologist (April, 1866), and was, as far as known to me, the first of his published papers. No copy of it has been found, and its exact title, date and paging are unknown.

Report of the Geological Survey of North Carolina, Vol. I, Physical Geography, Resumé, Economical Geology. By W. C. Kerr. Raleigh, 1875. 8 vo., XVIII, 324 and 120 pp., 9 plates and geological map.

Report of State Geologist on the Expenditures of the Geological Survey. Pub. Doc. No. 21. Session 1876-'77, 17 pp. (W. C. Kerr).

Report of State Geologist Concerning the Establishment of a State Department of Agriculture, etc. N. C. Pub. Doc. No. 32. Session 1876-'77, 12 pp. (W. C. Kerr).

Physiographical Description of North Carolina. By W. C. Kerr, State Geologist. Raleigh, 1879. 8 vo., 32 pages and map.

The Gold Gravels of North Carolina. By W. C. Kerr, State Geologist, Raleigh, North Carolina. Trans. Am. Inst. Mining Engineer, Vol. VIII, pp. 462-466, 1880.

The Mica Veins of North Carolina. By W. C. Kerr, State Geologist, Raleigh, North Carolina. Trans. Am. Inst. Mining Engineer, Vol. VIII, pp. 457-462, 1880.

Remarks in Discussion on Maynard's Gold Specimen. Trans. Am. Inst. Mining Engineer, Vol. VIII, pp. 456-457, 1880. (W. C. Kerr).

Minerals and Mineral Localities of North Carolina; being Chapter I of Second Volume of the Geology of North Carolina. Raleigh, 1881. 8 vo., 122 pages. (F. A. Genth and W. C. Kerr).

Origin of Some New Points in the Topography of North Carolina; by W. C. Kerr, State Geologist of North Carolina. Am. Jour. Sci., III, xxi, 1881, pp. 216-19.

Action of Frost in the Arrangement of Superficial Earthy Material; by Professor W. C. Kerr. Am. Jour. Sci., III, xxi, 1881, pp. 345-58.

Some Peculiarities in the Occurrence of Gold in North Carolina. By W. C. Kerr, State Geologist, Raleigh, North Carolina. Trans. Am. Inst. Mining Engineer, Vol. VIII, pp. 456-457, 1882.

Map of North Carolina. By W. C. Kerr, State Geologist, assisted by Capt. William Cain, C. E. Scale ten miles to the inch. New York, 1882.

The Geology of Hatteras and the Neighboring Coast (Abstract). By W. C. Kerr. Bull. Phil. Soc. Washington, D. C., Vol. V, 1883, pp. 28-30.

Report on the Swamp Lands (of North Carolina). By W. C. Kerr, State Geologist (being a report made to his Excellency, Jonathan Worth, Governor of North Carolina, in 1866). Raleigh, 1883, 23 pp.

North Carolina, the article on, in the Encyclopædia Britannica, 9th Edi., Vol. XVII, 1884. (W. C. Kerr).

Report on the Cotton Production of North Carolina, with a discussion of the General Agricultural Features of the State. By W. C. Kerr, State Geologist, Special Census Agent. Tenth Census Report, Vol. VI, Part II, 1884, 83 pp.

Report on the Cotton Production of the State of Virginia, with a brief discussion of the General Agricultural Features of the State. By W. C. Kerr, State Geologist of North Carolina, Special Agent. Tenth Census Report, Vol. VI, Part II, 1884, 25 pp.

Distribution and Character of the Eocene Deposits in Eastern North Carolina. By W. C. Kerr. Journal of the Elisha Mitchell Scientific Society, 1884-'85, pp. 79-84.

Notes on the Geology of the Region about Tampa, Florida. By W. C. Kerr. Journal of the Elisha Mitchell Scientific Society, 1884-'85, pp. 86-90.

Ores of North Carolina (being Chapter II of the Second Volume of the Geology of North Carolina). By W. C. Kerr and George B. Hanna. Raleigh, N. C., 1887. 8 vo.

The following papers were read before the American Association for the Advancement of Science, at a meeting held at Boston, Mass., August, 1880, but not published in the proceedings (see Proceedings A. A. A. S., Vol. 29, pp. 603-604, 1880):

Ancient Topography of North Carolina.

Recent Geology as Illustrated in the Coast Region of North Carolina.

Some Points in the Structure of Mica Veins in North Carolina.

A New Mode of Vein Formation.

Brief reports on the operations of the survey, made to the Board of Agriculture by Professor Kerr, are to be found in the Monthly Bulletins of the North Carolina Department of Agriculture for December, 1880; January, 1881 (misprinted 1880); July, 1881; January, February, March, April and June, 1882.

The following short papers were published by Professor Kerr, as State Geologist, in the Bulletin above mentioned:

Mineral Wealth of North Carolina—Mo. Bull. N. C. Dept. Agr., Feb., 1881 (misprinted 1880).

Water-power and Other Manufacturing Facilities of North Carolina—Mo. Bull. N. C. Dept. Agr., March, 1881.

Chart and Instructions for Silk Growers in North Carolina—Mo. Bull. N. C. Dept. Agr., April, 1881.

The History of Silk Culture in North Carolina—Mo. Bull. N. C. Dept. Agr., May and June, 1881.

On Some Useful Plants—Mo. Bull. N. C. Dept. Agr. for February, March, April and June, 1882.

THE STUDY OF LOCAL FLORAS.

GERALD MACCARTHY, B. Sc.

Every State in the Union has a flora more or less peculiar to itself, and there is scarcely a county in any State which has not its local rarities, found nowhere else.

Almost every community, too, has its botanical enthusiast, who is not infrequently of the tender sex. Useful work has been and is being done by these isolated observers. But because of the lack of organized effort, and of a clear apprehension of the end to be achieved by botanical study, a great deal of well-meant energy is misapplied and wasted.

The capital error of most amateurs and beginners in botany is the exaggerated opinion they entertain as to the value of the herbarium.

There is said to exist in Hindostan a sect of religious enthusiasts who infest the high-roads by which travelers enter India for the purpose of ingratiating themselves into the confidence of strangers, whom they then entice into some lonely spot and murder as a sacrifice to the goddess Kali.

We have among ourselves a class of scientific enthusiasts, worshippers of the mummy god Herbario, who with unwearied patience and tireless limb hound high-road and byway, bog and mountain peak, ever on the look-out for floral strangers, whom they ruthlessly sacrifice to the glue-and-paper deity.

To laboriously collect, dessicate, poison and mount plants on sheets of costly white paper, and then lay them away in a cabinet probably never to be disturbed during the owner's life-time, may be good physical exercise, and is scarcely more straining upon the brain than whistling. But it is a question whether this is science. It certainly is not religion, nor yet common sense, both of which prescribe as the proper aim of the activity of a rational creature, "the greater glory of God and the improvement of man's estate." It is probably true that a herba-

riunist now and then stumbles upon a useful fact, and in the aggregate, taking the whole country into account, these discoveries amount to something; but that the discoveries are not commensurate with the energy absorbed is a matter that admits of no debate.

As far as the average student is concerned, the study of plant life may be rationally pursued for two purposes, namely: for the mental discipline it affords and for the useful information it furnishes bearing upon the affairs of practical life. But the average student is usually content to study his plants only just so far as may be necessary to learn their names and proper places in the herbarium. This sort of information is certainly not practical, and as for the mental discipline it affords, after the student has once got the "key" well under control, it promises even less than whistling; for the whistler is often, greatly to his moral and spiritual welfare, kicked by men and bitten by dogs, whereas the herbariumist is too frequently the victim of the indiscriminating and hurtful praise of the vulgar. The only real use subserved by a collection of dried plants is that it enables nomenclators to compare one species with another so as to determine their relationship and position in the natural system; and as a pendant to this, to preserve typical specimens for the purpose of giving stability to botanical nomenclature. It is necessary that plants should have distinctive and well recognized names, so that they may be intelligently studied by different botanists and generations of botanists. But the herbariumist works in a circle. He studies his plants for the purpose of learning their names, notwithstanding that nomenclators have already named them that they might be studied.

Gray, Chapman, Vasey and Watson have so thoroughly systematized the nomenclature of American plants that very little now remains to be done in that line, and that little can be done only by botanists who have access to extensive museums and libraries, such as no private collector can hope to own. Isolated collectors can be of real service to the cause of science and human progress only by placing their services at the command

of the curators of some of the larger public and semi-public herbaria, of which the country has already an ample supply.

The Gray herbarium at Cambridge, Mass., would alone be sufficient for all necessary purposes. Besides this, there are at the National Capital two large collections: one at the Department of Agriculture, of which Dr. George Vasey is curator; the other at the National Museum, in charge of Professor Lester F. Ward. These herbaria are public property and may be consulted in person by any student, or by letter addressed to the respective curators. As the value of such collections depends largely upon their completeness, private collectors should take pride in making them as complete as possible by depositing with them all their more valuable typical specimens, and by collecting further under the intelligent direction of the curators.

But this kind of botany, though not to be despised, is not the most valuable work that the local botanist may do. He may, by observation and experiment, seek to discover the useful and noxious properties of the plants more or less peculiar to his locality; the environment most affected by particular species; the means by which they accomplish the fertilization of their ovules and the dispersion of their seeds; the effect of wet and dry, hot and cold seasons upon plant growth; the parasites they harbor, and many other interesting, useful and yet unsolved problems in plant physiology and pathology. A single student of this sort of botany may do more in a life-time to advance the cause of human progress than can be accomplished by the united labors of any number of herbariumists continued through all eternity.

Activity of whatever kind which subserves no useful purpose in regard to human welfare is a criminal abuse of the trust Humanity has reposed in each one to whom she has given the power of thinking and acting, that they might thereby smooth her pathway and accelerate her progress toward perfection. Viewed solely as a means of disciplining the intellectual faculties, botany is unequalled by any other of the natural or physical sciences.

Botany is pre-eminently the science of observation, and the observing faculty is the most fundamental faculty of the mind. Observation supplies the solid foundation upon which all the higher faculties must rest, when they rest upon anything. Without such a foundation, and the check a well disciplined observing faculty places upon the imagination, the latter faculty is very apt to run away with the judgment. We daily see, often to our cost, how inherited instincts and developed prejudices so pervert judgment and reason that two men of equal respectability and mental calibre, if they belong to different political faiths, will make diametrically opposite reports concerning the working of some law or set of circumstances.

As already remarked, neither for mental discipline nor for useful knowledge does the private herbarium subserve any useful purpose. But it would perhaps be over-sanguine to expect that a simple expostulation like this will suffice to convert the present generation of herb-secreting botanists.

According to the famous law of Mr. Darwin, the modern herbariumist, while deluding himself with the fancy that he is doing something useful, is in reality merely gratifying a once useful instinct which has outlasted its function—an instinct inherited from a long line of herbivorous and nucivorous, prehensile-tailed ancestors.

Since, then, the private herbarium may not be done away with at a stroke, some directions tending to shorten the time absorbed in the mechanical work of the herbarium may not be wholly out of place.

In the first place, good, symmetrical and full-grown plants should be selected for specimens. Collect the whole plant—root and branch—when not over three feet high. When higher than this, that length, measuring downwards from the top, may be cut off; and in addition, a few inches of the stem with the leaves next the ground, and the root, should be secured.

Of trees, flowering twigs, showing the bark as well as leaves and flowers, will suffice. A sharp knife to cut off twigs, a trowel to dig up roots, an air-tight tin box of convenient size,

and a pocket magnifier, are all the apparatus necessary for field work. A good drying-press is two latticed frames $12\frac{1}{2} \times 18\frac{1}{2}$ inches. These can be made out of a few laths by any one. The best drying paper is the soft felt paper used by builders and for placing under carpets. Common straw wrapping paper will, however, do very well. Pressure may be applied by means of a cord or trunk-strap passed around the package and pulled as tight as a good strong arm can do it—sixty pounds at first, and afterward one hundred pounds, is the proper pressure to apply. The package thus compressed should be hung up in the sunshine and air, or placed near the kitchen stove. The paper must be changed every day for the first three days. After that the press may be left alone till the plants are entirely dry, which will take two or three days more. Plants should, when possible, be identified and labelled before putting to press, but labelling may be done afterward. Under the usual routine, the next thing would be to soak the dried specimens in a solution of corrosive sublimate, re-dry them, and then mount them on heavy white paper by means of gummed slips. But all this work may be well dispensed with. Procure a supply of soft, uncalendared manilla paper in double sheets, size $11\frac{1}{2} \times 17\frac{1}{2}$ inches. Take four parts of white arsenic, five parts of washing soda; boil in thirty-five parts of clear rain-water for fifteen minutes, or until the solids are dissolved. Replace the water evaporated with water heated to boiling. Into this solution the manilla sheets are to be dipped, holding them by the open edge. It is best to keep two or three inches of the open edge unwetted, so that in turning over the leaves the fingers may not get burnt by the poison. The wet sheets are to be spread out in the sunshine to dry. Between the leaves of these poisoned sheets the plants with their labels are to be laid, but not attached. The labels had better be written on pretty thick card-board so that they will not easily “dog’s-ear.” Arrange the species of each genera alphabetically and enclose the whole in a thin genus cover in the usual way. Write on the lower left-hand corner the name and serial number of the genus, and the name of the natural order to which it belongs. Arrange

the genera of each family according to their serial numbers, and place them between two thick genus covers, opening into each other. Write on the lower left-hand corner of the package the name and serial number of the natural order, and place around the whole a stout elastic band, or a piece of tape, to keep all snug and tight.

The packages thus made up, each containing the plants of one natural order only, or, if the order be too extensive, a part of an order, are to be laid away in pasteboard or other kind of boxes of sufficient size to receive the packages without compressing. It is best to have the boxes all of uniform depth. Those used in the herbarium of the United States National Museum are $12\frac{7}{8}$ x $18\frac{1}{2}$ x $6\frac{1}{4}$ inches. They are of stout pasteboard, covered with black muslin. The cover comes off in the usual way; the front end is hinged at the bottom and falls down when the cover is lifted up, exposing the labelled ends of the enclosed packages. Each box has a brass ring fastened to the outside of the front end by means of which it is readily pulled out of its pigeon-hole. Spaces for the name of owner and for the names of the natural orders inclosed are also provided. The names of the genera included may, if desired, be written or pasted on the *inside* of the hinged end. A small piece of naphthaline should be pinned in one corner of the box. The odor of this substance is very disagreeable to insects, and will prevent the female insect from entering to deposit her eggs. The boxes, arranged in regular succession, may be kept on racks, in the cases usually employed, or as suits the fancy; but so that any one box may be taken out and returned without disturbing the rest.

THE LIMITS OF THE SENSES.

F. P. VENABLE.

It is surely a profitable field of research, in this age of the credulity of science, to see what limits are set to the powers of investigation themselves. The error of believing all things within the grasp of natural science is, at least, as common as that of setting too narrow bounds to this ever-progressing branch of human knowledge. Of late several efforts have been made to determine how far man is capable of laying hold upon the secrets of the nature that environs him. To gather and sum up these results, together with whatever additional facts experiments have enabled us to learn, will lead to a clearer conception of our powers and of the boundaries of man's field of work.

We are brought into communication with our environment by means of five or more senses. By means of these senses only can we examine into the nature of that environment. In fact, it is through them only that we are aware of the existence of such an environment. The settlement of the question as to how far-reaching these senses may be is rendered difficult by the two facts: first, that they are highly susceptible of training, and hence we meet with them in different degrees of perfection in different individuals, and secondly, that by various appliances man has found it possible greatly to extend and amplify some of them, giving them wonderfully increased powers. It is not possible, then, to state that the end has been reached; that the particular organ of sense can never be trained to a higher degree of perfection, or that no improvement upon such appliance and instruments can ever be designed. We can at best but learn the limits of present knowledge together with the probabilities of further progress. Not only are the limits of the unaided senses to be pointed out, but as well those of the instruments that aid or magnify them.

Most important in the field of physical investigation are the senses of taste, of smell, and of sight. The sense of touch may be very marvellously developed in some cases, especially where there is a deficiency in one or more of the other senses. This compensating power of nature is true of all the senses, and of course must be taken into account in any discussion of their bounds. The loss of one results in greatly increased acuteness of the others. What may be true of the sense in its normal or average condition would have to be greatly modified for it when thus abnormal. The limit found in the one case must be extended much farther in the other. It is highly probable that this increase of power in the remaining senses is chiefly the reward which Nature places upon increased training and that similar power can be attained without the loss of any of the senses by subjecting oneself to equally careful training. It is well known that the blind can easily distinguish the nature of objects which they pass, even though at quite a distance from them. The test of touch is one of the earliest we apply from our infancy on, yet from its superficial nature it can solve but few of the problems and explain scarcely any of the mysteries which surround us.

Akin to the sense of touch is the temperature sense. It is not generally known, though researches at Upsala and Neissa and Baltimore have shown, that on our bodies we have spots capable only of sensations of heat, others capable only of cold, and between the two those capable of neither heat nor cold, but of pressure only. These spots have even been carefully mapped out. They are very small and are easily exhausted. With all their sensitiveness, however, these spots are not capable of measuring heat very delicately. The sensations, too, are based on no fixed standard. The measurement of temperature by means of a thermometer without a degree marked upon it would be mere guess-work and memory, and this is the case with this "temperature sense." Hence the frequent recurrence of phenomenal temperature, summer and winter, exceeding the bounds of the memory of the "oldest inhabitant." It is warm, it is cold, according as the preceding sensation was colder or warmer.

We must, then, to decide this matter of temperature, have recurrence to auxiliary appliances, these recording their results through the sense of sight. As achievements in this line we have a mercurial thermometer, reading to the one-thousandth part of a degree, the exceedingly delicate bolometer of Langley, and lastly Vernon Boys' modification of D'Arsonval's instrument, which he calls the Radiomicrometer. This last measures the one hundred-millionth of a degree. In the report of its exhibition before the Royal Society it is said to show the heat cast by a candle-flame on a half-penny piece 1,168 feet distant. This gives the present limit to our process of determining temperature, and there is no reason for saying that this limit may not at some time be transcended.

The sense of hearing seems to reach its limits rather quickly. As, according to the theory of sound, hearing is but the result of the beating of sound-waves upon apparatus placed within the ear, it does not lie far to infer that the bounds of hearing will be determined by the sensibility to the greater or less rapidity of the strokes. It is found that sounds with less than sixteen beats to the second and those with more than thirty-five thousand do not impress themselves upon the average ear. A wide scope, but still a decided limit, and we can let the fancy play at will among the "voiceless" sounds which must fill the world around us.

When we consider the sense of sight we find assistance from magnifying instruments very essential. The limit of the unaided sight is soon reached. If a line an inch long be cut into ten equal parts we can easily see each separate one. If divided into one hundred such parts they merge into one another, and it requires a clear vision to separate them. This separation is easily accomplished by the microscope, however. Yet when each one of these divisions is further divided into one thousand, or the whole line into one hundred thousand, even the microscope and light itself fails us, for at this point the waves of the light-rays interfere with one another and the divisions, though sharp-cut, seem blurred. So that the very force of nature which affects the organ of sight itself sets a limit to its usefulness.

Just as the ear can adapt itself only to sounds having a limited range of beats or wave-lengths, so the eye can receive impressions from those rays only which move within a limited range of velocity. Beyond the red rays of the solar spectrum are many, quite invisible to the eye because of the length of their waves and the slowness of their movement, yet readily detected by a thermometer or thermopile. And so beyond the blue are very many invisible rays, too rapid and short in their motion, which are revealed to us by means of sensitized paper and which can only be seen then in their photographs. There are rays of light, then, of which the eye takes no cognizance which have an important warming and life-giving part to play in nature. We are forced to recur to the thermometer and that valuable coadjutor in scientific research, the photographic apparatus, to detect and measure these for us. If we retain the old definition of light as the force of which we are sensible by means of the organs of sight, can we call those light-rays which do not affect the optic nerves, and if not light, what are they?

Astronomers tell us that imperfections of instruments, impurities and peculiarities of the atmosphere, limit the usefulness and the power of telescopes. Apparently not much more is hoped from the expensive and laborious enlarging of the glass lenses. No wonderful revelation is looked forward to. The limit in this line seems nearly reached.

In the spectroscope we have a wonderful and powerful instrument, and one from which much has been expected. One of the greatest workers with the spectroscope, Dr. Crookes, whose painstaking patience seems almost marvellous, tells us that its vision extends almost to infinitesimal particles. Of sodium, for instance, we can detect the one fourteen hundred-thousandth part of a milligramme.

One would hardly suspect that the sense of smell was more delicate than that of sight, yet the researches of Fischer and Penzoldt have shown that the nose is capable of detecting some substances with a delicacy two hundred and fifty times greater than the spectroscope. That is, without any external assistance,

it is more far-reaching into the realm of Nature's little things than the most powerful instrument devised to aid the eye. How infinitesimally small must be the particles which for years arise from the few grains in a box of musk, and yet the sense of smell can unerringly detect them. How tiny the particles of perfume rising from some small flower and scenting the breezes for hours—that is, conferring fragrance upon many miles of air. Still how easily the delicate nostril detects the presence of the sweet fragrance.

This would seem to open up a new field of work for the analyst, offering him most delicate assistance, and indeed Dr. Crookes suggests as much, but unfortunately, though so easily affected by some substances, the great majority of them do not affect the organ of smell at all, or in very slight degree, no matter in what quantity they may be used. So far as the quantity of matter is concerned, it is usually the case that the smell becomes less and less apparent as the quantity is increased, after a certain limit is reached. If too much otto of roses or hydrogen sulphide be used, the sense of fragrance or of its opposite is largely lost.

Turning now to the sense of taste, the last of these senses to be investigated, I can find no reported experiments upon its delicacy. Apparently only a few approximate statements have been made with regard to one or two substances. I have with some care experimented upon this point with a few characteristic substances, utilizing the sense of taste of two persons so as to partly eliminate personal errors. Known weights of the substances, dissolved in the proper solvent, were diluted until the taste was barely perceptible, a slight further dilution causing its disappearance. The results show the sense of taste much less delicate than that of smell. Of sugar, $\frac{3}{1000}$ of a gramme barely tastes; of salt, $\frac{1}{1000}$; of acid (hydrochloric), $\frac{1}{10000}$; of saccharin $\frac{5}{1000000}$, and of strychnine $\frac{5}{10000000}$ of a gramme gave barely a perceptible taste, and this was the greatest delicacy of taste, or persistency of taste, reached with the substances experimented upon. If we compare the delicacy of taste towards

strychnine with the delicacy of the spectroscope towards sodium, we find the latter in the neighborhood of one hundred times stronger.

These, then, are the bounds of our senses, so far as can at present be determined. That they were unlimited was not to be expected. Yet when we see these limits there is no room for a feeling of disappointment that man cannot grasp everything. The field for his powers is almost infinitely vast as it is, and the only cause for discouragement lies in the sharp limit put to the attainment of knowledge by the short space of his working time.

THE ELEMENTS, HISTORICALLY CONSIDERED.

F. P. VENABLE.

According to the modern definition an element is the simplest form of matter. It cannot be further decomposed nor reduced. Other elements may be added to it and compounds formed, but nothing can be taken from it when in its elemental state. If it can be decomposed it ceases to be considered an element. Hence we can only state that such and such forms of matter are elements, because at present no means of reducing them is known.

This is an interpretation which has gradually grown up. In earlier times the idea was rather that of the genesis of matter. This last has been a puzzle which man has long striven to solve, and not merely a vexed question of these modern days, as we, in our arrogant assumption of vast intellectual superiority, are apt to think. Dr. Gladstone, in his address before the British Association, at its meeting of 1883, says: "In the childhood of the human race the question was eagerly put, 'By what process were all things made?'" Shoo King, the most esteemed of Chinese classics, comprises the Great Plan with nine divisions. The first division relates to five elements—water, fire, wood, metal, earth. And this idea of the genesis of matter is attached

to the word element down to a little more than a century ago, when in Macquer's Dictionary of Chemistry—English Translation, 1777—we meet with the modern definition, worded as follows:

“Those bodies are called elements which are so simple that they cannot by any known method be decomposed or even altered, and which also enter, as principal or constituent parts, into the combination of other bodies, which are therefore called compound bodies.” But he adds: “The bodies in which this simplicity has been observed are fire, air, water and the purest earths.”

In Table I, will be found the supposed primal elements at different periods, reaching as far back as history goes. It is but just to state that Dr. Crookes recognizes the insufficiency of data to support the theory of a primal element, and hardly does more than suggest “protyle” as an interesting possibility.

In Table II a list is given of those at present acknowledged to be elements, with the date of discovery and name of discoverer. With regard to the dates of discovery, it is interesting to note that nine were known in the earliest historic times, four more were discovered before the eighteenth century, fifteen during the eighteenth century, and forty during the nineteenth century.

The last thirty years of the eighteenth century form an especial season of activity. Twelve out of the fifteen elements discovered during that century were discovered in those years. Taking the present century by decades we find that fourteen elements were discovered in the first, four in the second, seven in the third, five from fourth to sixth, inclusive, three in the seventh, five in the eighth, and two in the ninth. Davy with his discoveries made 1808 the most prolific year, but Wöhler in 1828 runs him a close second.

As to nationality, Germany can claim the first rank with eighteen discovered elements. England comes next with seventeen, France lays claim to eleven, and the discovery of the remainder is due mainly to the labors of Scandinavians. It is

strange that while other countries have elements named in their honor, England alone is without this distinction, notwithstanding her sons have been so industrious and successful in their search.

Table III gives a list of the supposed elements discovered since the modern era of chemistry. It is difficult to make such a list complete, as mistakes and errors in science, as elsewhere, are very numerous, and this is in large measure a list of mistakes. It can only be said of the present list that it is as complete as the literature at command would admit of. Wherever possible the dates when the errors were found out are also given.

The latter portion of the table cannot be called a list of errors. It represents new work, however, and that so recently completed that other workers have not as yet fully substantiated the results. When such confirmation is complete these "supposed elements" would have to be transferred to Table II.

With regard to dates and names in both of these last tables (II and III) one meets with some confusion and contradictory statements. This is especially true in Table II. The best authorities and evidence attainable have been followed.

TABLE I—PRIMAL ELEMENTS.

| AUTHORITY. | DATE. | PRIMAL ELEMENTS. |
|----------------------|--------------------|---|
| "Shoo King"..... | Before 1100 B. C.. | Water, fire, wood, metal, earth. |
| Indian tradition.... | Before 1000 B. C.. | Subtle ether, air, light or fire, water, earth. |
| Thales..... | 600 B. C..... | Water. |
| Anaximenes | | Air. |
| Heraclytus | | Fire. |
| Theraclidos. | | Earth. |
| Aristotle | | Fire, air, water, earth. |
| Persians | | Fire. |
| Egyptians..... | | Water. |
| Geber..... | 8th century..... | Sulphur and mercury. |
| Albertus Magnus... | 13th century..... | Sulphur, arsenic and water. |
| Basil Valentine..... | 15th century..... | Sulphur, mercury and salt. |
| Paracelsus..... | 16th century..... | Sulphur, arsenic, salt. |
| Van Helmont..... | 17th century.. .. | Water, air? |
| Boyle | 17th century..... | Defined elements as we do, but did not name them. |
| Becher | 17th century..... | Water, terra lapidea, terra pinguis, terra fluida. |
| Lemery..... | 17th century..... | Water, spirit, oil, salt, earth. |
| Boerhaave | 18th century..... | Says it is a question not to be answered by chemistry. |
| Macquer..... | 1777..... | Fire, air, water, earth. |
| Majority chemists... | 1770-1780..... | Phlogiston, water, acid of sulphur, phosphorus, metallic oxides, the earths, the alkalis. |
| Prout | 1815..... | Hydrogen. |
| Crookes | 1886..... | Protyle. |

TABLE II—ELEMENTS.

| NAME. | DISCOVERER. | DATE. |
|-----------------|-----------------------------|---------------|
| Aluminium..... | Wöhler | 1828. |
| Antimony..... | Basil Valentine | 1490-1500. |
| Arsenic..... | Brandt | 1733. |
| Barium..... | Davy..... | 1808. |
| Boron..... | Gay Lussac and Thenard..... | 1808. |
| Bismuth..... | Basil Valentine | 15th century. |
| Bromine..... | Balard..... | 1826. |
| Cadmium..... | Stromeyer..... | 1818. |
| Caesium..... | Bunsen and Kirchhoff | 1860. |
| Calcium..... | Davy..... | 1808. |
| Carbon..... | | |
| Cerium..... | Klaproth | 1803. |
| Chlorine..... | Scheele..... | 1774. |
| Chromium..... | Vauquelin | 1797. |
| Cobalt..... | Brandt | 1735. |
| Columbium..... | Hatchett | 1801. |
| Copper..... | Prehistoric | |
| Didymium..... | Mosander..... | 1841. |
| Erbium..... | Mosander..... | 1843. |
| Fluorine..... | Moissan | 1886. |
| Gallium..... | De Boisbaudran | 1875. |
| Germanium..... | Winkler..... | 1886. |
| Glucinum..... | Wöhler | 1828. |
| Gold..... | Prehistoric | |
| Hydrogen..... | Cavendish..... | 1781. |
| Indium..... | Reich and Richter | 1875. |
| Iodine..... | Courtois | 1812. |
| Iridium..... | Tennant | 1804. |
| Iron..... | Prehistoric | |
| Lanthanum..... | Mosander | 1839. |
| Lead..... | Prehistoric | |
| Lithium..... | Arfwedson..... | 1817. |
| Magnesium..... | Davy..... | 1808. |
| Manganese..... | Gahn..... | 1774. |
| Mercury..... | Very early..... | |
| Molybdenum..... | Hjeltn | 1782. |
| Nickel..... | Cronstedt | 1751. |
| Nitrogen..... | Rutherford | 1772. |
| Osmium..... | Tennant | 1804. |
| Oxygen..... | Priestley..... | 1774. |
| Palladium..... | Wollaston | 1803. |
| Phosphorus..... | Brandt | 1669. |
| Platinum..... | Watson | 1750. |
| Potassium..... | Davy..... | 1807. |
| Rhodium..... | Wollaston | 1801. |
| Rubidium..... | Kirchhoff and Bunsen | 1860. |
| Ruthenium..... | Claus | 1846. |
| Samarium..... | De Boisbaudran | 1878. |
| Scandium..... | Nilson | 1879. |
| Selenium..... | Berzelius..... | 1817. |
| Silicon..... | Berzelius..... | 1823. |
| Silver..... | Prehistoric | |
| Sodium..... | Davy | 1807. |
| Strontium..... | Davy | 1808. |
| Sulphur..... | Prehistoric | |
| Tantalum..... | Ekeberg..... | 1802. |
| Tellurium..... | Klaproth..... | 1798. |
| Thallium..... | Crookes | 1861. |
| Thorium..... | Berzelius | 1828. |
| Tin..... | Prehistoric | |
| Titanium..... | Gregor | 1789. |
| Tungsten..... | D'Elhujar | 1783. |
| Uranium..... | Klaproth..... | 1789. |
| Vanadium..... | Sefstrom | 1831. |
| Ytterbium..... | Marignac..... | 1878. |
| Yttrium..... | Wöhler | 1828. |
| Zinc..... | Paracelsus..... | 16th century. |
| Zirconium..... | Berzelius..... | 1824. |

TABLE III—SUPPOSED ELEMENTS.

| NAME OF ELEMENT. | DISCOVERER. | DATE. | WHERE FOUND. | PROVED TO BE | DATE. |
|-------------------------|----------------------|---------|---------------------|--|-------|
| Hydrosiderum | Meyer | 1789... | Cold short iron... | Iron phosphide... | |
| Siderum | Bergman | 1781... | Cold short iron... | Iron phosphide... | |
| Terra Nobilis | " | 1777... | Diamond | | |
| Saturnit | Monnet | 1784... | Lead ore | | |
| Peculiar Earth | Klaproth | 1786... | Diamond spar | $\text{SiO}_2, \text{Al}_2\text{O}_3, \text{Fe}_2\text{O}_3$ | |
| Sydenia | Wedgwood | 1790... | Sand | $\text{SiO}_2, \text{Al}_2\text{O}_3, \text{Fe}_2\text{O}_3$ | |
| Agusterde | Frommsdorff | 1800... | Beryl | Calc'm phosph'ate : | |
| Andronia | Winterl | 1800... | | | |
| Thelike | " | 1800... | Marble | | |
| Alkali Pneum | Hahnemann | 1801... | | Borax | |
| Erythronium | Del Rio | 1803... | Lead ore | Lead vanadate... | |
| Nikolannum | Richter | 1805... | Nickel ore | Impure nickel... | |
| Vestium or Sirium | Vest | 1818... | Nickel ore | Impure nickel... | |
| Wodanium | Lampadius | 1818... | Cobalt ore | Impure nickel... | |
| Crodonium | Frommsdorff | 1820... | Sulphuric acid. .. | Im're magn'sia... | |
| Aurum Millium | Mills | 1820... | | | |
| Pluralium | Osann | 1829... | Platinum metals.. | | |
| Ilmenium | Hermann | | | Niobium | |
| Donium | Richardson | 1836... | | Alumina | |
| Donarium | Bergman | | | Thorium | 1863 |
| Norium | Svanberg | 1845... | | | 1863 |
| Pelopium | H. Rose | 1846... | | Niobium | |
| Aridium | Ullgreen | 1850... | | $\text{Fe}_2\text{O}_3, \text{Cr}_2\text{O}_3, \text{P}_2\text{O}_5$ | 1854 |
| Dianium | Von Kobell | 1860... | | Niobium | |
| Wasium | Bahr | 1863... | | | |
| A new earth | Bischoff | 1863... | | | |
| Davyum | Kern | 1877... | Platinum ores ... | Pr'bly mix'tre... | |
| Neptunium | Hermann | 1877... | Columbite | | |
| Lavoesium | Prat | 1877... | Pyrite | | |
| Mosandrum | Lawrence Smith | 1877... | Samarskite | | |
| New earths | Garland | 1878... | Unnamed min'r'l .. | | |
| Phillippium | Delafontaine | 1878... | Samarskite | | |
| Decipium | " | 1878... | Samarskite | | |
| X | Soret | 1878... | Gadolinite | Mixture | 1887 |
| Norwegium | Dahll | 1879... | Gersdorffite | | |
| Uralium | Guyard | 1879... | Platinum | | |
| Thulium | Cleve | 1879... | Gadolinite | Mixture | 1887 |
| Holmium | " | 1879... | Gadolinite | Mixture | 1887 |
| Columbium | Lawrence Smith | 1879... | Samarskite | | |
| Rogorium | " | 1879... | Samarskite | | |
| Vesbium | Seacchi | 1879... | Lava | Venad'm oxide... | |
| Comesium | Kaemmerer | 1880... | | | |
| Y _A | Marignac | 1880... | Gadolinite | | |
| Y _B | " | 1880... | Gadolinite | | |
| Actinium | Phipson | 1881... | Zinc ores | | |
| Di _B | Cleve | 1882... | Gadolinite | | |
| Nameless | Wilm | 1883... | Platinum ores | | |
| Idunium | Welsky | 1884... | Lead Vanadate ... | | |
| Neodymium | Welsbach | 1885... | Didymium | Mixture | 1887 |
| Praseodymium | " | 1885... | Didymium | Mixture | 1887 |
| Z _A | Boisbaudran | 1885... | Didymium | | |
| Z _B | " | 1885... | Didymium | | |
| Z _C | " | 1886... | Terbia | | |
| Austrium | Linneman | 1886... | | Mixture? | 1886 |
| Dysprosium | Boisbaudran | 1886... | | Mixture | 1887 |
| D _A | Crookes | 1886... | Didymium | | |
| S _B | " | 1886... | Samarskite | | |
| S _C | " | 1886... | Samarskite | | |
| G _A | " | 1886... | Gadolinite | | |
| G _B | " | 1886... | Gadolinite | | |
| G _C | " | 1886... | Gadolinite | | |
| G _D | " | 1886... | Gadolinite | | |
| G _E | " | 1886... | Gadolinite | | |
| G _F | " | 1886... | Gadolinite | | |
| G _G | " | 1886... | Gadolinite | | |
| Polymnestum | Pringle | 1886... | Ferruginous Q'tz .. | | |
| Unnamed | " | 1886... | Ferruginous Q'tz .. | | |
| Enbodium | " | 1886... | Ferruginous Q'tz .. | | |
| Gadenium | " | 1886... | Ferruginous Q'tz .. | | |

TABLE III—PRIMAL ELEMENTS (CONTINUED).

| NAME OF ELEMENT. | DISCOVERER. | DATE. | WHERE FOUND. | PROVED TO BE | DATE. |
|-----------------------|-----------------------------|---------|------------------------|--------------|-------|
| Hesperisium | Pringle | 1886... | Ferruginous Q'tz | | |
| Unnamed | " | 1886... | Ferruginous Q'tz | | |
| X _A | DeBoisbaudran & Cleve | 1887 .. | Soret's X | | |
| X _B | " | 1887... | Soret's X | | |
| X _C | " | 1887... | Soret's X | | |
| X _D | " | 1887... | Soret's X | | |
| X _E | " | 1887... | Soret's X | | |
| X _F | " | 1887... | Soret's X | | |
| X _G | " | 1887... | Soret's X | | |
| Er _A | Kruss & Nilson | 1887... | Erbium | | |
| Er _B | " | 1887... | Erbium | | |
| Tm _A | " | 1887... | Thulium | | |
| Tm _B | " | 1887... | Thulium | | |
| Di _A | " | 1887... | Didymium | | |
| Di _B | " | 1887... | Didymium | | |
| Di _C | " | 1887... | Didymium | | |
| Di _D | " | 1887... | Didymium | | |
| Di _E | " | 1887... | Didymium | | |
| Di _F | " | 1887... | Didymium | | |
| Di _G | " | 1887... | Didymium | | |
| Di _H | " | 1887... | Didymium | | |
| Di _I | " | 1887... | Didymium | | |
| Sm _A | " | 1887... | Didymium | | |
| Sm _B | " | 1887... | Didymium | | |
| New earths | Demarcay | 1887... | Cerite | | |

NOTE.—Mr. J. C. Roberts rendered valuable assistance in preparing Table III.

CONTRIBUTIONS FROM THE N. C. AGRICULTURAL EXPERIMENT STATION.

No. XVI.

EFFECT OF DECOMPOSING ORGANIC MATTER ON INSOLUBLE PHOSPHATE OF LIME.

F. B. DANCY.

Some time ago I instituted a few rough experiments with a view to ascertaining if the process of decomposition of organic matter, or the products of such decomposition, had any effect on tri-calcic phosphate of lime in the way of converting it, or any part of it, into its soluble form. The first results were of such a character that the experiments were not carried on to the extent originally contemplated, but I thought it might be well to call attention to them as far as they went.

For my samples I selected, first, a good specimen of ground bone, containing 40.01 per cent. phosphate of lime and 54.02 per cent. volatile-and-organic matter, and ground fine enough to pass a 60-mesh sieve. Next, I chose an especially pulverulent sample of South Carolina phosphate "floats," and then selected some good fish-scrap, ground to pass a 40-mesh sieve, and some excellent specimens of cotton seed meal, dried blood, and "ammonite," all ground to pass a 60-mesh sieve. In all these samples I determined the per cent. of phosphate of lime and of volatile-and-organic matter. I then made four mixtures, consisting of fish-scrap and floats, cotton seed meal and floats, dried blood and floats and ammonite and floats, in such proportions by calculation that the content of volatile-and-organic matter in each should be the same as in the ground bone, namely, 54.02 per cent.

I then took 25 grammes of the ground bone and 25 grammes of each of the four mixtures, rubbed them up well with water in mortars, and transferred them to filters in funnels, let the water extract filter through, and then washed the contents of the filters with successive portions of water until my filtrates amounted to, I think, about a liter each. I then stopped the ends of the funnels with little stoppers and left the moist contents to rot at the ordinary temperature of the laboratory, with free access of air. During the process of the decomposition I kept the masses moist by additions of water from time to time, and, by stirring them, kept fresh portions turned up and exposed to the air.

I found the per cents. of soluble phosphoric acid in my fine samples, just after mixing and before rotting (obtained in the filtrates just alluded to), to be:

TABLE I—BEFORE ROTTING.

| | | | |
|-----------------------------|--------|-----------|--------------------|
| 1. Bone meal | 0.1149 | per cent. | Soluble P_2O_5 . |
| 2. Fish and floats..... | 0.1292 | " | " |
| 3. Meal and floats..... | 0.0486 | " | " |
| 4. Blood and floats..... | 0.0289 | " | " |
| 5. Ammonite and floats..... | 0.1537 | " | " |

In seventeen days the mass of moist bone meal was thoroughly rotted, and a week later the other mixtures showed that they, too, were well decomposed throughout. The putrid smell from each of the five was highly offensive—almost unbearable. I now leached out the soluble again with the same amount of water as at first. The filtration was exceedingly slow, requiring about six days, so slowly did the successive additions of water percolate through the putrid masses.

In my filtrates I determined the soluble phosphoric acid as before, and found it to be as follows:

TABLE II—AFTER ROTTING.

| | | | |
|------------------------------|--------|-----------|--------------------|
| 1. Bone meal | 0.0634 | per cent. | Soluble P_2O_5 . |
| 2. Fish and floats..... | 0.0894 | “ | “ |
| 3. Meal and floats..... | 0.1561 | “ | “ |
| 4. Blood and floats | 0.0969 | “ | “ |
| 5. Ammonite and floats..... | 0.1052 | “ | “ |

The filtrates, reeking as they were with organic matter, possessed a more or less opacity, and I was led to suspect that in the cases of 2, 3, 4 and 5 there might be some of the finer portions of the floats passed the filter. So I evaporated these four filtrates down, which caused a separation and collection of the suspended matter, and filtered each into two parts, determining the phosphoric acid in each of the filtrates and residues thus obtained. The figures given in Table II are the sum of these two determinations in each case. In every case but 3 (that of the cotton seed meal) the phosphoric acid in the residue was in excess of that in the filtrate, tending to show that most of the phosphoric acid leached out from the rotted samples was mechanically carried through the filter rather than passed in genuine solution. The cotton seed meal seems to have had most effect. But, granting that the whole of it was carried through in genuine solution, the per cent. is so small as to show that little reliance can be placed on the decomposition of the organic matter with which our insoluble phosphates are in contact as to rendering these phosphates soluble.

What assistance the soil may give should the decomposition take place there, or what aid the plant juices may lend to the end desired, must be determined by more elaborate experimentation.

Had the per cent. of soluble phosphoric acid been considerable after the first rotting it was intended to carry on the rotting further and see the effect of prolonged decomposition, but as the effect brought about by thorough putridity was so insignificant it was concluded that further investigation would be a loss of time on these particular experiments.

CONTRIBUTIONS FROM THE BIOLOGICAL LABORATORY OF THE UNIV. OF N. C.

No. VI.

PRELIMINARY CATALOGUE OF THE BIRDS OF
NORTH CAROLINA, WITH NOTES ON SOME OF
THE SPECIES.

GEORGE F. ATKINSON.

PREFACE.

Object of the catalogue. Previous to the work which was undertaken to prepare the present preliminary catalogue, very little systematic effort had been made in the study of the birds to be found in the State of North Carolina. Of the earlier works mention should be made of Catesby's *Natural History of the Carolinas*;* but this work covered an extent of territory much larger than North Carolina, and included species which belong to an entirely distinct fauna.

*The *Natural History of Carolina, Florida, and the Bahama Islands*, by Mark Catesby. 1771.

Beside the Woody Plants of North Carolina* and a catalogue of the flowering plants and cryptogams† of the State, the Rev. M. A. Curtis prepared for publication a "Description of the Quadrapeds" and a "Description of the Reptiles" of North Carolina. It is unfortunate that an appropriation was not made for the publication of these valuable reports; and still more so that the manuscript copies are probably lost, as frequent search has thus far failed to reveal their existence. In the letter‡ which recommends the publication of the above two reports Mr. Curtis says, "I have also in preparation, if desired, a 'Description of the Birds of North Carolina.'" The extent of his work upon the birds of the State remains as yet unknown, whatever portions of it were completed being wrapped in the same obscurity which involves his work on the quadrapeds and reptiles.

The object of the present catalogue is the enumeration of the birds which have been observed and absolutely identified within the State since about 1880, though most of the work has been done since 1884 and 1885; together with notes on their occurrence, distribution, and nesting. The work is recognized as incomplete in that it is a *preliminary catalogue*. The hope that the publication now of the records of the work, so far as it has progressed, may stimulate a desire in resident North Carolinians in different parts of the State to collect material and record observations of the birds to be found within our State limits; and the knowledge that the present catalogue would not only convey some useful information, but serve as a convenient pamphlet for reference and check list, induces me to present it in its present imperfect form.

*Geological and Natural History Survey of North Carolina, Part III, Botany. The Woody Plants of the State, with descriptions of the Trees, Shrubs, and Woody Vines.

† *Ibid.* Part III, Botany. Containing a catalogue of the Indigenous and Naturalized Plants of the State. 1867.

‡ Through the kindness of Professor Holmes I had the privilege of consulting the letter from Rev. M. A. Curtis to His Excellency, Governor Worth, January 27, 1866.

Material. The collection of material at Chapel Hill was begun by myself in January, 1886; and, assisted by some of my students in the laboratory, has been continued to the present time, though no collections were made during the summer and fall of 1886. University duties interfere greatly with collection of material during the time for transient visitors, but such time as has been practicable has been zealously devoted to the collection and preservation of material for study and future reference. In all about 120 species have been observed and absolutely identified by myself at Chapel Hill; 112 species have been preserved. In December, 1887, I visited Beaufort and New Bern, examined the collections of Mrs. Geoffroy and Mr. A. Piner, at Beaufort, and that of Clark and Morgan at New Bern; and also made some collections and observations in the vicinity of Beaufort, in all absolutely identifying about 50 species in addition to those taken at Chapel Hill.

I am greatly indebted to H. H. & C. S. Brimley,* taxidermists of Raleigh, for records of species collected and observed by them during a period extending over the last four or five years, in the vicinity of Raleigh, Currituck Sound, New Bern and Beaufort. One hundred and seventy-five species were noted in the vicinity of Raleigh, many of these being duplicated and some additions made from the coast region.

I have also had for reference "A List of Birds of Buncombe County, N. C.," by John S. Cairns,† Weaversville, N. C. This list enumerates 169 species observed in Buncombe county.

Mr. Charles F. Batchelder, of Cambridge, Mass., kindly sent me a copy of a pamphlet‡ describing his observations upon the winter birds of the mountain region in 1886. In this he enumerates 40 species.

* Any parties desiring good skins for mounting, or wishing any work from a taxidermist, will do well to write to Mr. Brimley. I have seen specimens of his workmanship. The work is in every way satisfactory.

† Ornithologist and Oologist, Vol. XII, No. 1, 1887.

‡ The North Carolina Mountains in Winter, by Charles F. Batchelder. The Auk, Vol. III. 1886, pp. 307-314.

Mr. William Brewster, of Cambridge, Mass., curator of birds and mammals in the Museum of Comparative Zoology, loaned me a copy of a pamphlet* describing a two weeks tour in the mountain region, from which I have gleaned the most important information concerning the occurrence of the summer visitors of that region. This pamphlet enumerates 102 species.

The private collection of James Busbee, of Raleigh, contains 87 North Carolina species, most of which were collected in the vicinity of Raleigh. This list furnishes some very rare occurrences.

I take this opportunity of recognizing the aid given, in determining the nesting of our birds, by Drs. Kemp P. and Herbert B. Battle, of Raleigh, from a collection of eggs made by them. The eggs were recently determined by the curator of oology at the Smithsonian institution. The list contains 57 North Carolina species.

Where credit is due any of the above named gentlemen for observations on any but our very common birds, I have given it under each species.

Rich variety of bird life. A glance at the map of the Eastern United States will show that North Carolina is peculiarly situated, not only with reference to its central position from north to south, and its great extent east and west, but also in the variety of its physical features. It is situated between the parallels of latitude $33\frac{7}{8}^{\circ}$ and $36\frac{3}{5}^{\circ}$ north, and longitude $75\frac{1}{2}^{\circ}$ and $84\frac{1}{3}^{\circ}$ west from Greenwich; approximately 580 miles long from Cape Hatteras to the western limits of Cherokee county, and 200 miles wide in the vicinity of Cape Fear, with 300 miles of sea-coast in the east and 200 miles of mountain range in the west. The coast region, with Currituck, Albemarle, and Pamlico, and the lesser sounds, with the attendant estuaries, numerous rivers, and extensive salt and fresh water marshes, invites vast numbers of Diving Birds, Long-winged-, Totipalmate-, and Lamellirostral-Swimmers, Shore Birds, Herons, Ibises, Rails,

* An Ornithological Reconnaissance in Western North Carolina, by William Brewster. The Auk, Vol. III, No. 1, January, 1886.

etc., and becomes, from its extent in central position, the recipient of many extra-limital species from the fauna to the north and south. Perhaps no place east of the Rockies is more interesting in proportion to its area than is the mountain region of Western North Carolina. It possesses the highest peak east of the Rocky Mountains. Starting in the valleys at the foot of some of the highest peaks, in the ascent of the mountain side we can pass through successively four different faunæ, the Louisianian, Carolinian, Alleghanian, and Canadian,* having represented as it were upon one mountain side characteristic species from an extent of territory reaching from the Gulf States to British America. In the middle region nature has also provided for the retention of numbers and variety of the feathered kind, notwithstanding the encroachment of human civilization upon their primeval haunts. The “rolling” character of the surface with its attendant tree- and bush-begirt streams and valleys; the worn-out hillsides grown up to “old field pine”; and the steep rocky places incapable of cultivation, offer a peaceful harbor to such as are not yet emboldened to live near the habitation of man.

The varied climate in different sections also testifies to the natural adaptation of the State to the reception of widely different faunæ, or the same fauna at different parts of the State at different seasons of the year. The following table will illustrate the average temperature of the different regions for the four seasons of the year. The figures are taken from a table made by the North Carolina Geological Survey, covering observations made during eight to fifteen years in various parts of the State. I select only those figures which represent the temperature of the regions I have chosen for use in the present pamphlet.

| | SPRING. | SUMMER. | AUTUMN. | WINTER. |
|----------------------|---------|---------|---------|---------|
| Mountain region..... | 52° | 70° | 59° | 36° |
| Middle region..... | 57° | 76° | 58° | 40° |
| Coast region..... | 59° | 77° | 63° | 45° |

* See Auk, Vol. III, No. 1. January, 1886. Brewster.

These represent the average taken from a number of places in each region. In the mountain region it gives no adequate idea of the temperature upon the upper slopes of the highest mountains, where we have represented the Canadian fauna. A table for Smithville, in the extreme south-eastern part of the State, will illustrate how much warmer is such a southern point on the coast.

| | SPRING. | SUMMER. | AUTUMN. | WINTER. |
|-------------------|---------|---------|---------|---------|
| Smithville | 63° | 79° | 66° | 49° |

In the mountain region, for example, we find on the higher mountains as summer sojourners Wilson's Thrushes, Yellow-throated Vireos, Rose-breasted Grosbeaks, Winter Wrens, Golden-crested Kinglets, etc., which in the middle region are only winter visitors, or only transients going to Middle America, Northern South America, or the West Indies for the winter; while some, the Towhee Bunting (*Pipilo erythrophthalmus*), for example, are summer sojourners in the mountain region, transients in the middle, and winter visitors in the coast region, and the extent of the State from north to south scarcely exceeds $2\frac{1}{2}$ degrees latitude! We cannot, of course, say that the same individuals spend the entire year in the State, but it would not be singular if quite a number of the summer visitors to the mountain region pass eastward with the approach of winter and reside for the time in the coast region.

While at Beaufort in the latter part of December, 1887, Catbirds (*Galeoscoptes carolinensis*), Brown Thrashers (*Harporthynchus rufus*), Towhee Buntings (*Pipilo erythrophthalmus*), were in abundance, and evidently settled down for the winter. I was told that they were common during the winter.

Take such a point as Smithville, and we might expect to find quite a number of winter visitors that are only known as transients in the middle, and summer sojourners in the mountain region.

Rare species, and non-occurrence of species once abundant. As rare species we may reasonably expect to take, at least in the south-east part of the State, nearly all the species commonly accredited to South Carolina. The taking of *Helinaia swainsonii* by Brimley is an evidence of this. The nesting of *Peuceea æstivalis bachmani* at Chapel Hill also shows how well adapted North Carolina is for species accredited usually to the States farther south. A glance at the map will show that Smithville is only one degree of latitude north of Charleston, while it is more than one degree south of the northern border of South Carolina.

The disappearance of the Ivory-billed Woodpecker and the Carolina Paroquet from North Carolina and the other States constituting the northern portions of their habitat, and their restriction to the Gulf States, furnish examples of the change of distribution of some species, as affected by changes in their environment. It would not be surprising if at some time in the not far future they should become extinct species. They are placed in the present catalogue because of their former abundance in the State, and the possibility that their restriction to more southern districts may prevent their ever being taken in the State again. They should be looked for in the south-eastern part of the State.

Preserve a rich avian fauna. The value of birds as scavengers, in destroying injurious insects, and their value in affording objects for the cultivation of our perception of the beautiful, is well recognized. Birds are subject to the same laws in the struggle for existence that other animals are, and man should take care that unnecessary encroachments upon their existence be avoided. The reckless and indiscriminate collection and robbing of birds' nests, which annually cuts off thousands of the possible increase of beautiful and useful birds, should be stopped. The merciless and wholesale slaughter, which sometimes takes place during the migration of birds to their summer abodes, should cease. Laws to this effect would be of little avail without the support of an interested public sentiment. Let a

few men in various parts of the State devote their spare time to the study of the birds of their section, recording the result of their observation; let a general knowledge of the habits and usefulness of birds become a part of the instruction in the common schools, and ere long the birds will be in such popular favor that they will be encouraged to come and stay, instead of being gradually driven to remote regions and to possible extinction.

Explanation of terms in the catalogue. In arranging the catalogue I have followed the "Canons of Nomenclature" adopted by the American Ornithologists Union.

The catalogue enumerates 255 species and subspecies.

An Appendix is added, consisting of 81 species and subspecies, which we may reasonably expect to take, with careful work, within the limits of the State. This would make in all 336 species and subspecies, and there is a hopeful possibility of the number being still farther increased by the appearance of casual and accidental visitors.

The numbers in parenthesis correspond with those of the A. O. U. Check List of North American Birds.

The vernacular name adopted by the A. O. U. is placed immediately following the scientific name, and in some cases synonymic vernacular names are added in quotation.

(Coll. of 1877) refers to specimens which were collected at Chapel Hill, during the spring of 1877, by several students at the University.

(Univ. Coll.) refers to the specimen deposited in the University museum. Any one wishing to donate specimens to the University may be assured that they will be well cared for, and properly labelled.

The numbers marked * are species known to breed in the State. Many others breed, but we have as yet no positive evidence of the fact.

CATALOGUE.

Order PYGOPODES. Diving Birds.

Family PODICIPIDÆ. Grebes.

Genus COLYMBUS Linnæus.

Subgenus COLYMBUS.

1. (2). *C. holboëllii* (Reinh.). Holboëll's Grebe. Chapel Hill. (Coll. 1877). J. I. Dunlap.

Subgenus DYTES Kaup.

2. (3). *C. auritus* Linn. Horned Grebe. Currituck Sound, February, 1884; rather common (Brimley).

Genus PODILYMBUS Lesson.

3. (6). *P. podiceps* (Linn.). Pied-billed Grebe. Middle and coast regions, common in the latter place. (Univ. Coll.).

Family URINATORIDÆ. Loons.

Genus URINATOR Cuvier.

4. (7). *U. imber* (Gunn.). Loon. Winter visitor, rather rare. (Univ. Coll.).

5. (11). *U. lumme* (Gunn.). Red-throated Loon. Coast, winter visitor.

Order LONGIPENNES. Long-winged Swimmers.

Family LARIDÆ. Gulls and Terns.

Genus LARUS Linnæus.

6. (51a). *L. argentatus smithsonianus* Coues. American Herring Gull. Coast, common in winter.

7. (54). *L. delawarensis* Ord. Ring-billed Gull. Coast, rather rare.

*8. (58). *L. atricilla* (Linn.). Laughing Gull. Coast, common, breeds. The young are so different in color from the

adults that fishermen generally insist that they are a different species. They call them "Fool Gull." Mr. Piner tells me the name is given them because they can be so easily approached and shot, due as he rightly judges to the fact that they are young.

9. (60). *L. philadelphia* (Ord.). Bonaparte's Gull. Middle and coast regions, not very common.

Genus STERNA Linnæus.

Subgenus THALASSEUS Boie.

10. (65). *S. maxima* Bodd. Royal Tern. Coast, rather common.

Subgenus STERNA.

11. (69). *S. forsteri* Nutt. Forster's Tern. Coast, common.

12. (70). *S. hirundo* Linn. Common Tern. Coast, common.

Subgenus STERNULA Boie.

*13. (74). *S. antillarum* (Less.). Least Tern. Coast, common, breeds.

Subgenus HALIPLANA Wagler.

14. (75). *S. fuliginosa* Gmel. Sooty Tern. Coast, common.

Genus HYDROCHELIDON Boie.

15. (77). *H. nigra surinamensis* (Gmel.). Black Tern. Coast, common.

Family RYNCHOPIDÆ. Skimmers.

Genus RYNCHOPS Linnæus.

16. (80). *R. nigra* Linn. Black Skimmer. Coast, common.

Order TUBINARES. Tube-nosed Swimmers.

Family PROCELLARIDÆ. Fulmars and Shearwaters.

Genus PUFFINUS Brisson.

17. (88). *P. borealis* Cory? Cory's Shearwater. I saw at Beaufort a wing of one of the Shearwaters taken at that place. From the length of the wing, and from a description of the bird given to me, I judge it to be this species.

Order STEGANOPODES. Totipalmate Swimmers.

Family PHALACROCORACIDÆ. Cormorants.

Genus PHALACROCORAX Brisson.

Subgenus PHALACROCORAX.

18. (120). *P. dilophus* (Sw. & Rich.). Double-crested Cormorant.

Family PELECANIDÆ. Pelicans.

Genus PELECANUS Linnæus.

Subgenus CYRTOPELICANUS Reichenbach.

19. (125). *P. erythrorhynchus* Gmel. American White Pelican. One taken by Brimley on State Carp Ponds, Raleigh, May 12, 1884.

Order ANSERES. Lamellirostral Swimmers.

Family ANATIDÆ. Ducks, Geese, and Swans.

Genus MERGANSER Brisson.

20. (129). *M. americanus* (Cass.). American Merganser. Coast, rather rare. (Coll of 1877).

21. (130). *M. serrator* (Linn.). Red-breasted Merganser. Coast, rare.

Genus LOPHODYTES Reichenbach.

22. (131). *L. cucullatus* (Linn.). Hooded Merganser. Coast, common; middle region, rare.

Genus ANAS Linnæus.

Subgenus ANAS.

23. (132). *A. boschas* Linn. Mallard. Winter visitor, common.

24. (133). *A. obscura* Gmel. Black Duck. Winter visitor, rare in middle region, common on coast.

Subgenus CHAULELASMUS Bonaparte.

25. (135). *A. strepera* Linn. Gadwall. Coast, common; middle region, rare.

Subgenus MARECA Stephens.

26. (137). *A. americana* Gmel. Baldpate. Coast, common.

Subgenus NETTION Kaup.

27. (139). *A. carolinensis* Gmel. Green-winged Teal. Transient visitor, sometimes common on coast, rare in middle region.

Subgenus QUERQUEDULA Stephens.

28. (140). *A. discors* Linn. Blue-winged Teal. Transient visitor, rather rare.

Genus SPATULA Boie.

29. (142). *S. clypeata* (Linn.). Shoveller. Coast, rare. "Spoonbill."

Genus DAFILA Stephens.

30. (143). *D. acuta* (Linn.). Pintail. Transient visitor, coast, rare. Called also "Sprigtail."

Genus AIX Boie.

- *31. (144). *A. sponsa* (Linn.). Wood Duck. Resident; entire State; recorded by Batchelder in mountain region during winter. Brewster says it breeds numerously along the mountain streams.

Genus AYTHYA Boie.

Subgenus AYTHYA.

32. (146). *A. americana* (Eyt.). Redhead. Winter visitor; middle and coast region, rather rare.

33. (147). *A. vallisneria* (Wils.). Canvas-back. Rare.

Subgenus FULIGULA Stephens.

34. (148). *A. marila nearctica* Stejn. American Scaup Duck. Winter visitor, rare in middle region; common on coast.

35. (149). *A. affinis* (Eyt.). Lesser Scaup Duck. Winter visitor, very common on coast. Called also "Black-head."

36. (150). *A. collaris* (Donov.). Ring-necked Duck. Winter visitor, coast, rather rare.

Genus GLAUCIONETTA Stejneger.

37. (151). *G. clangula americana* (Bonap.). American Golden-eye. Coast, winter visitor, rather rare.

Genus CHARITONNETTA Stejneger.

38. (153). *C. albeola* (Linn.). Buffle-head. Winter visitor, middle region, rare; coast, common.

Genus CLANGULA Leach.

39. (154). *C. hyemalis* (Linn.). Old-squaw. Winter visitor, coast, rare.

Genus OIDEMLA Fleming.

Subgenus MELANITTA Boie.

40. (165). *O. deglandi* Bonap. White-winged Scoter. Casual winter visitor. One taken at Beaufort.

Subgenus PELIONETTA Kaup.

41. (166). *O. perspicillata* (Linn.). Surf Scoter. Winter visitor, coast, rare. One taken at Beaufort.

Genus ERISMATURA Bonaparte.

42. (167). *E. rubida* (Wils.). Ruddy Duck. Probably a resident. Common in winter. Called also "Paddy," "Light-wood Knot," "Butter-ball." Names applied also to several related species.

Genus CHEN Boie.

43. (—). *C. caerulescens* (Linn.). Blue Goose. Determined from a live specimen in possession of S. J. Moore, Beaufort. Has been in captivity for three years; taken on Bogue Beach, one mile from Fort Macon, by James Willis, of Morehead City in spring of 1884; rare.

44. (169a). *C. hyperborea nivalis* (Forst.). Greater Snow Goose. Winter visitor, rare.

Genus ANSER Brisson.

45. (171a). *A. albifrons gambeli* (Hartl.). American White-fronted Goose. Buncombe county (*vide* Cairns).

Genus BRANTA Scopoli.

46. (172). *B. canadensis* (Linn.). Canada Goose. Winter visitor, rather common.

47. (173). *B. bernicla* (Linn.). Brant. Winter visitor, rather common in Beaufort market, December, 1887.

Genus OLOR Wagler.

48. (180). *O. columbianus* (Ord.). Whistling Swan. Currituck Sound, February, 1884, common (Brimley).

Order HERODIONES. Herons, Storks. Ibises, Etc.

Family CICONIIDÆ. Storks and Wood Ibises.

Genus TANTALUS Linnæus.

49. (188). *T. loculator* Linn. Wood Ibis. One killed at Garners, five miles south of Raleigh, July, 1884 (Brimley).

Family ARDEIDÆ. Herons, Bitterns, Etc.

Genus BOTAURUS Hermann.

Subgenus BOTAURUS.

50. (190). *B. lentiginosus* (Montag.). American Bittern. Rather rare. Has various popular names, "Stake Driver," "Thunder Pump," etc.

Subgenus ARDETTA Gray.

51. (191). *B. exilis* (Gmel.). Least Bittern. Rare; occasionally taken in marshes of the coast region.

Genus ARDEA Linnæus.

Subgenus ARDEA.

52. (194). *A. herodias* Linn. Great Blue Heron. Summer sojourner, rather common.

Subgenus HERODIAS Boie.

53. (196). *A. egretta* Gmel. American Egret. Rather rare. Sometimes called "White Crane."

Subgenus GARZETTA Kaup.

54. (197). *A. candidissima* Gmel. Snowy Heron. Coast, rare. One from Wilmington in collection of James Busbee, Raleigh. One in collection of A. Piner, Morehead City.

Subgenus FLORIDA Baird.

55. (200). *A. cerulea* Linn. Little Blue Heron. Rare.

Subgenus BUTORIDES Blyth.

*56. (201). *A. virescens* Linn. Green Heron. Generally distributed, common. Commonly called "Schytepoke," "Fly-up-the-creek," etc.

Genus NYCTICORAX Stephens.

Subgenus NYCTHERODIUS Reichenbach.

57. (203). *N. violaceus* (Linn.). Yellow-crowned Night Heron. One taken at Beaufort, May, 1887; mounted by firm of Clark & Morgan, New Bern.

Order PALUDICOLÆ. Cranes, Rails, Etc.

Family RALLIDÆ. Rails, Gallinules, and Coots.

Genus RALLUS Linnæus.

*58. (208). *R. elegans* Aud. King Rail. Summer sojourner, rare.

59. (211). *R. longirostris crepitans* (Gmel.). Clapper Rail. Coast region, abundant (Brimley).

60. (212). *R. virginianus* Linn. Virginia Rail. Coll. Clark and Morgan.

Genus PORZANA Vieillot.

Subgenus PORZANA.

61. (214). *P. carolina* (Linn.). Sora. Transient visitor, rare. (Univ. Coll.). "Carolina Rail," "Ortolan," etc.

Subgenus COTURNICOPS Bonaparte.

62. (215). *P. noveboracensis* (Gmel.). Yellow Rail. Rare. One captured alive near Raleigh, September, 1882 (Brimley).

Genus IONORNIS Reichenbach.

63. (218). *I. martinica* (Linn.). Purple Gallinule. Rare. One taken June 6th, 1887, by Brimley, near Raleigh.

Genus GALLINULA Brisson.

64. (219). *G. galeata* (Licht.). Florida Gallinule. Rare. One specimen taken by Brimley in New Bern, 1885. One taken near Asheville by Brewster in early summer of 1885.†

Genus FULICA Linnaeus.

65. (221). *F. americana* Gmel. American Coot. Common in coast region; rare in middle region. One walked into Mr. McCauley's store at Chapel Hill on the night of April 8, 1887, at 8 o'clock, and was captured. A heavy wind and rain storm was prevailing, and had continued all day. (Univ. Coll.).

Order LIMICOLÆ. Shore Birds.

Family SCOLOPCIDÆ. Snipes, Sandpipers, Etc.

Genus PHILOHELA Gray.

*66. (228). *P. minor* (Gmel.). American Woodcock. Generally distributed, rather rare.

Genus GALLINAGO Leach.

67. (230). *G. delicata* (Ord.). Wilson's Snipe. Rather common, transient throughout the State.

Genus MACRORHAMPUS Leach.

68. (231). *M. griseus* (Gmel.). Dowitcher. Common in coast region, rare in middle region. One killed July, 1884, on State Carp Ponds, near Raleigh, by Brimley.

69. (232). *M. scolopaceus* (Say). Long-billed Dowitcher. Identified from one specimen seen at Beaufort.

Genus TRINGA Linnaeus.

Subgenus ACTODROMAS Kaup.

70. (239). *T. maculata* Vieill. Pectoral Sandpiper. Rare. One taken by Brimley at Raleigh, April 2, 1886.

71. (242). *T. minutilla* Vieill. Least Sandpiper. Transient visitor, common in coast, rather rare in middle, and very rare in mountain region. (Brimley and Cairns).

† See "Auk," Vol. III, No. 1, January, 1886.

Subgenus PELIDNA Cuvier.

72. (243a). *T. alpina pacifica* (Coues). Red-backed Sandpiper. Identified from two specimens seen at Beaufort.

Genus CALIDRIS Cuvier.

73. (248). *C. arenaria* (Linn.). Sanderling. Common in winter in coast region.

Genus TOTANUS Bechstein.

Subgenus GLOTTIS Koch.

74. (253). *T. melanoleucus* (Gmel.). Greater Yellow-legs. Raleigh, reported by Brimley for April, 1887.

75. (255). *T. flavipes* (Gmel.). Yellow-legs. Middle and coast regions, transient visitor, rather rare.

Subgenus RHYACOPHILUS Kaup.

76. (256). *T. solitarius* (Wils.). Solitary Sandpiper. Transient visitor, middle and mountain regions, rather common. I have seen this bird, when frightened by being wounded, swim under water, using its wings as oars.

Genus SYMPHEMIA Rafinesque.

*77. (258). *S. semipalmata* (Gmel.). Willit. Beaufort, common (Brimley).

Genus BARTRAMIA Lesson.

78. (261). *B. longicauda* Bechst. Bartramian Sandpiper. Raleigh, April, 1887 (Brimley).

Genus ACTITIS Illiger.

79. (263). *A. macularia* (Linn.). Spotted Sandpiper. Resident in mountain region (Brewster and Cairns). Thus far determined as transient visitor in middle region.

Genus NUMENIUS Brisson.

80. (264). *N. longirostris* Wils. Long-billed Curlew. Beaufort, common (Brimley).

Family CHARADRIIDÆ. Plovers.

Genus CHARADRIUS Linnæus.

Subgenus SQUATAROLA Cuvier.

81. (270). *C. squatarola* (Linn.). Black-bellied Plover. Identified from one specimen at Beaufort.

Subgenus CHARADRIUS Linnæus.

82. (272). *C. dominicus* Müll. American Golden Plover. One taken at Raleigh in autumn, 1884. Rare, transient.

Genus ÆGIALITIS Boie.

Subgenus OXYECHUS Reichenbach.

*83. (273). *A. vocifera* (Linn.). Killdeer. Resident, generally distributed, rather common. (Univ. Coll.).

Subgenus ÆGIALITIS Boie.

84. (274). *A. semipalmata* Bonap. Semipalmated Plover. Rare transient, taken by Brimley at Raleigh in May, 1884.

Family APHRIZIDÆ. Surf Birds and Turnstones.

Genus ARENARIA Brisson.

85. (283). *A. interpres* (Linn.). Turnstone. Beaufort, rather common (Brimley).

Order GALLINÆ. Gallinaceous Birds.

Family TETRAONIDÆ. Grouse, Partridges, Etc.

Genus COLINUS Lesson.

*86. (289). *C. virginianus* (Linn.). Bob-White. Very common throughout the State. Called "Partridge" at the South, "Quail" at the North. (Univ. Coll.).

Genus BONASA Stephens.

*87. (300). *B. umbellus* (Linn.). Ruffed Grouse. Mountain region. Not very common. At breeding season above altitude of 4,000 feet. Mountain people say it is as common in valleys as at high elevations. Brewster thinks this may be true in autumn and winter, but doubts it during breeding season. Occurs as far east as Old Fort (*vide* Brewster).

Family PHASIANIDÆ. Pheasants, Etc.

Genus MELEAGRIS Linnæus.

*88. (310). *M. gallapavo* Linn. Wild Turkey. Resident, generally distributed. Rare in some localities, rather common in others. (Eggs in Univ. Coll.).

Order COLUMBÆ. Pigeons.

Family COLUMBIDÆ. Pigeons.

Genus ECTOPISTES Swainson.

89. (315). *E. migratorius* (Linn.). Passenger Pigeon. Rare transient (Brimley and Cairns).

Genus ZENAIDURA Bonaparte.

*90. (316). *Z. macroura* (Linn.). Mourning Dove. Generally distributed, resident, rather common. (Univ. Coll.).

Order RAPTORES. Birds of Prey.

Family CATHARTIDÆ. American Vultures.

Genus CATHARTES Illiger.

*91. (325). *C. aura* (Linn.). Turkey Vulture. Resident, very common.

Genus CATHARISTA Vieillot.

*92. (326). *C. atrata* (Bartr.). Black Vulture. Resident, common.

Family FALCONIDÆ. Vultures, Falcons, Hawks, Eagles, Etc.

Genus ELANOIDES Vieillot.

93. (327). *E. forficatus* (Linn.). Swallow-tailed Kite. Casual in mountain region (*vide* Cairns).

Genus CIRCUS Lacepede.

94. (331). *C. hudsonius* (Linn.). Marsh Hawk. Winter visitor, rather common.

Genus ACCIPITER Brisson.

Subgenus ACCIPITER.

95. (332). *A. velox* (Wils.). Sharp-shinned Hawk. Rather common. (Univ. Coll.). Rare resident in mountain region (*vide* Cairns).

96. (333). *A. cooperi* (Bonap.). Cooper's Hawk. Resident, rather common and generally distributed throughout the State. Sometimes called "Blue Darter," "Chicken Hawk," "Pigeon Hawk," which latter two names are also applied to *A. velox*. Probably *A. velox* and *cooperi* both breed in the State. (Univ. Coll.).

Genus BUTEO Cuvier.

Subgenus BUTEO.

97. (337). *B. borealis* (Gmel.). Red-tailed Hawk. Rather common; probably resident throughout the State; reported as resident in mountain region (*vide* Cairns). (Priv. Coll.).

*98. (239). *B. lineatus* (Gmel.). Red-shouldered Hawk. Resident, common throughout the State.

99. (342). *B. swainsoni* Bonap. Swainson's Hawk. Reported as accidental in mountain region (*vide* Cairns).

100. (343). *B. latissimus* (Wils.). Broad-winged Hawk. Reported from mountain region (*vide* Brewster). Also taken in vicinity of Raleigh (*vide* coll. of James Busbee).

Genus AQUILA Brisson.

*101. (349). *A. chrysaetos* (Linn.). Golden Eagle. Mountain region, resident. Said to breed on inaccessible cliffs and ledges of the higher mountains (*vide* Brewster).

Genus HALIÆTUS Savigny.

*102. (352). *H. leucocephalus* (Linn.). Bald Eagle. Resident, generally distributed, but rare. Said to breed in coast region; the young, in this section, during change of plumage, called by many "Gray Eagle."

Genus FALCO Linnæus.

Subgenus RHYNCHODON Nitzsch.

*103. (356). *F. peregrinus anatum* (Bonap.). Duck Hawk. Mountain region. Resident; mountaineers say they breed in same places many years in succession. They also believe they "go blind" in August and consequently die of starvation (*vide* Brewster).

Subgenus ÆSALON Kaup.

104. (357). *F. columbarius* Linn. Pigeon Hawk. One taken by Brimley near Raleigh, October 1, 1886.

Subgenus TINNUNCULUS Vieillot.

105. (360). *F. sparverius* Linn. American Sparrow Hawk. Resident, probably breeds. Also called "American Kestrel." (Univ. Coll.).

Genus PANDION Savigny.

106. (364). *P. haliaetus carolinensis* (Gmel.). American Osprey. Rare transient visitor for middle and coast region. Rare summer visitor in mountain region (*vide* Cairns).

Family BUBONIDÆ. Horned Owls, Etc.

Genus ASIO Brisson.

107. (366). *A. wilsonianus* (Less.). American Long-eared Owl. One taken near Raleigh, in coll. of James Busbee.

108. (367). *A. accipitrinus* (Pall.). Short-eared Owl. Rare, taken both at Raleigh (Brimley and Busbee) and in Buncombe county (*vide* Cairns).

Genus SYRNIUM Savigny.

*109. (368). *S. nebulosum* (Forst.). Barred Owl. Resident, generally distributed, rather common.

Genus MEGASCOPS Kaup.

*110. (373). *M. asio* (Linn.). Screech Owl. Resident, generally distributed, very common in middle, and coast, and rare in mountain region. (Univ. Coll.).

Genus BUBO Cuvier.

111. (375). *B. virginianus* (Gmel.). Great Horned Owl. Resident, generally distributed, though not very common.

Genus NYCTEA Stephens.

112. (376). *N. nyctea* (Linn.). Snowy Owl. Rare straggler to mountain region (*vide* Cairns).

Order PSITTAL. Parrots, Macaws, Paroquets, Etc.

Family PSITTACIDÆ.

Genus CONURUS Kuhl.

113. (382). *C. carolinensis* (Linn.). Carolina Paroquet. Formerly a resident of North Carolina, now confined to the Gulf States and Lower Mississippi Valley. Should be looked for as accidental in the south-eastern parts of the State.

Order COCCYGES. Cuckoos, Etc.

Family CUCULIDÆ. Cuckoos, Anis, Etc.

Genus COCCYZUS Vieillot.

*114. (387). *C. americanus* (Linn.). Yellow-billed Cuckoo. Summer visitor, generally distributed, common. (Univ. Coll.).

115. (388). *C. erythrophthalmus* (Wils.). Black-billed Cuckoo. Summer visitor, rare (Brimley). Common transient and rare summer visitor in mountain region (*vide* Cairns).

Family ALCEDINIDÆ. Kingfishers.

Genus CERYLE Boie.

Subgenus STREPTOCERYLE Bonaparte.

116. (390). *C. alcyon* (Linn.). Belted Kingfisher. Resident, generally distributed, common; probably breeds. (Univ. Coll.).

Order PICI. Woodpeckers, Wrynecks, Etc.

Family PICIDÆ. Woodpeckers.

Genus CAMPEPHILUS Gray.

117. (392). *C. principalis* (Linn.). Ivory-billed Woodpecker. Formerly a resident of North Carolina, now confined to the Gulf States and Lower Mississippi Valley. Should be looked for as accidental in the south-eastern parts of the State.

Genus DRYOBATES Boie.

118. (393). *D. villosus* (Linn.). Hairy Woodpecker. Mountain region, rare resident. Single male shot among balsams of Black Mountains; referred by some to *D. v. leucomelas* (*vide* Brewster). Reported also by Batchelder in winter, and by Cairns as a "rare resident."

119. (393b). *D. villosus audobonii* (Swains.). Southern Hairy Woodpecker. Resident, generally distributed, rather rare.

*120. (394). *D. pubescens* (Linn.). Downy Woodpecker. Resident, common. (Univ. Coll.).

121. (395). *D. borealis* (Vieill.). Red-cockaded Woodpecker. Probably a resident of the coast region. I shot one December 14th, 1887, in marshy woodland about two miles from Beaufort. Standing in the road I could count at a dozen specimens within a few rods. They were searching very industriously on pine and oak trees for insects, and uttering a peculiar, sharp, "ch-r-r-r-r." (Priv. Coll.).

Genus SPHYRAPICUS Baird.

122. (402). *S. varius* (Linn.). Yellow-bellied Sapsucker. Common in fall, winter and spring; reported as resident in mountain region (*vide* Cairns). (Univ. Coll.).

Genus CEOPHLÆUS Cabanis.

*123. (405). *C. pileatus* (Linn.). Pileated Woodpecker. Resident, generally distributed, rare. Eggs taken in Buncombe county April 20, 1886, by Cairns. The adult is a very shy bird. When young they are comparatively tame. In June,

1887, four nearly full-grown ones came into the grove on the University grounds. After pursuing them for some time, and shooting one, they lighted in a large oak so near one of the buildings that I killed two at one shot from my open window. (Univ. Coll.).

Genus MELANERPES Swainson.

Subgenus MELANERPES.

124. (406). *M. erythrocephalus* (Linn.). Red-headed Woodpecker. Rare as resident, common in summer in localities; generally distributed. (Univ. Coll.).

Subgenus CENTURUS Swainson.

125. (409). *M. carolinus* (Linn.). Red-bellied Woodpecker. Resident, generally distributed, rather rare, but common at times in localities. Very common at Chapel Hill in autumn and winter of '87 and '88. (Univ. Coll.).

Genus COLAPTES Swainson.

*126. (412). *C. auratus* (Linn.). Flicker. Resident, generally distributed, common. Abundant as transient in Buncombe county, but rare in summer and winter (*vide* Cairns). In summer Brewster saw them in mountain region only on plateaus between 3,000 feet and 4,000 feet. Popularly known as "Yellowhammer," "Golden-winged Woodpecker," etc. (Univ. Coll.).

Order MACROCHIRES. Goatsuckers, Swifts, Etc.

Family CAPRIMULGIDÆ. Goatsuckers, Etc.

Genus ANTROSTOMUS Gould.

127. (416). *A. carolinensis* (Gmel.). Chuck-will's-widow. Raleigh, summer visitor, rather common.

*128. (417). *A. vociferus* (Wils.). Whip-poor-will. Summer visitor, generally distributed; less common in mountain region.

Genus CHORDEILES Swainson.

129. (420). *C. virginianus* (Gmel.). Nighthawk. Summer visitor, more common as transient; generally distributed. Brews-

ter records only one specimen seen near Asheville, though it was reported as of general occurrence. Buncombe county, common transient, and rather common summer visitor (*vide* Cairns). A specimen was brought me in August, 1887, while at Balsam Station, by a mountaineer. (Univ. Coll.).

Family MICROPODIDÆ. Swifts.

Genus CHÆTURA Stephens.

*130. (423). *C. pelagica* (Linn.). Chimney Swift. Generally distributed, summer visitor, common. (Univ. Coll.).

Family TROCHILIDÆ. Humming Birds.

Genus TROCHILUS Linnæus.

Subgenus TROCHILUS.

*131. (428). *T. colubris* (Linn.). Ruby-throated Hummingbird. Generally distributed, summer visitor, common. At Balsam Station, in August, I found this species exceedingly abundant. Called "Whizzers" by the mountaineers of that Section. (Univ. Coll.).

Order PASSERES. Perching Birds.

Family TYRANNIDÆ. Tyrant Flycatchers.

Genus TYRANNUS Cuvier.

*132. (444). *T. tyrannus* (Linn.). Kingbird. Summer visitor, common in middle and coast region, rather rare in mountain region. Called also "Bee Martin." (Univ. Coll.).

Genus MYIARCHUS Cabanis.

*133. (452). *M. crinitus* (Linn.). Crested Flycatcher. Summer visitor, generally distributed, common. (Univ. Coll.).

Genus SAYORNIS Bonaparte.

*134. (456). *S. phæbe* (Lath.). Phœbe. Generally distributed, rather rare in winter, common in summer. Middle region nests under bridges and in deserted buildings. I have taken the

bird from the nest. Brewster reports it as breeding under rocks and earth banks in mountain region. At Chapel Hill wrongly called "Cowbird" by egg collectors. (Univ. Coll.).

Genus *CONTOPUS* Cabanis.

*135. (459). *C. borealis* (Swains.). Olive-sided Flycatcher. Taken in south-east corner of Macon county by Brewster. He saw several pairs preparing to breed. Buncombe county, rare transient (Cairns).

*136. (461). *C. virens* (Linn.). Wood Pewee. Summer visitor, generally distributed, common. (Univ. Coll.).

Genus *EMPIDONAX* Cabanis.

*137. (465.) *E. acadicus* (Gmel.). Acadian Flycatcher. Common summer visitor in middle and mountain region. Brewster says it is common below 3,000 feet.

138. (467). *E. minimus* Baird. Least Flycatcher. Summer visitor, mountain region, generally distributed though not common (*vide* Brewster and Cairns).

Family *ALAUDIDÆ*. Larks.

Genus *OTOCORIS* Bonaparte.

139. (474). *O. alpestris* (Linn.). Horned Lark. Middle region, winter visitor, sometimes very common. (Univ. Coll.).

Family *CORVIDÆ*. Crows, Jays, Magpies, Etc.

Genus *CYANOCITTA* Strickland.

*140. (477). *C. cristata* (Linn.). Blue Jay. Resident, generally distributed, common. (Univ. Coll.).

Genus *CORVUS* Linnæus.

141. (486). *C. corax sinuatus* (Wagl.). Mexican Raven(?). The following subspecies (*C. c. principalis*) was separated from *C. c. sinuatus* by Ridgway since the latter was reported in the State. Brewster and Cairns both report the Raven from the mountain region; the former says it is "common almost everywhere above 3,000 feet." On the principle that the avian fauna of the higher portions of the mountain region is similar to that

of the Canadian avian fauna, as Brewster has shown, the form from this region would be that of the Northern Raven. In the absence of positive testimony on this point I place this subspecies in the list provisionally.

142. (—). *C. corax principalis* Ridgw. Northern Raven. One specimen taken by Clark and Morgan, of New Bern, and now in their possession, I have determined as belonging to this subspecies. I saw the specimen and took the following measurements: Length 26.50, wing 16.75, tail 10.25, tarsus 2.85, culmen 3.19, depth of bill at nostril 1.12. The Raven is reported from the coast region by Brimley, but no measurements given. It may be quite possible that both subspecies, and intergrade forms, would occur, situated, as the State is, somewhat between the Canadian and Mexican faunæ.

143. (488). *C. americanus* Aud. American Crow. Resident, generally distributed, common. (Univ. Coll.).

144. (490). *C. ossifragus* Wils. Fish Crow. New Bern (Clark and Morgan).

Family ICTERIDÆ. Blackbirds, Orioles, Etc.

Genus DOLICHONYX Swainson.

145. (494). *D. oryzivorus* (Linn.). Bobolink. Transient visitor, rare in the mountain region, more common eastward. (Coll. of 1877). Called also "Reedbird," "Ricebird."

Genus MOLOTHRUS Swainson.

146. (495). *M. ater* (Bodd.). Cowbird. Common transient.

Genus AGELAIUS Vieillot.

*147. (498). *A. phæniceus* (Linn.). Red-winged Blackbird. Resident throughout the State, common, rarer in mountain region, except as a transient, and confined to the lower valleys. (Priv. Coll.).

Genus STURNELLA Vieillot.

*148. (501). *S. magna* (Linn.). Meadowlark. Common in winter throughout the State; rare in summer in mountain region. Said to breed sparingly in Macon county (*vide* Brewster). (Univ. Coll.).

Genus ICTERUS Brisson.

Subgenus PENDULINUS Vieillot.

*149. (506). *I. spurius* (Linn.). Orchard Oriole. Summer visitor, common throughout the State and confined to low countries in mountain region. (Univ. Coll.).

Subgenus YPHANTES Vieillot.

150. (507). *I. galbula* (Linn.). Baltimore Oriole. Rare transient in middle region, rather rare summer visitor in mountain region; probably breeds there. One in Univ. Coll. taken by G. W. Edwards in Allegheny county.

Genus SCOLECOPHAGUS Swainson.

151. (509.) *S. carolinus* (Müll.). Rusty Blackbird. Rather common transient. (Univ. Coll.).

Genus QUISCALUS Vieillot.

Subgenus QUISCALUS.

*152. (511). *Q. quiscula* (Linn.). Purple Grackle. Common transient in middle and coast region, rather rare summer visitor in mountain region. Seen breeding in Asheville by Brewster. (Priv. Coll.).

Subgenus MEGAQUISCALUS Cassin.

153. (513). *Q. major* Vieill. Boat-tailed Grackle. Rare transient in mountain region (*vide* Cairns); common resident in coast region, where it probably breeds.

Family FRINGILLIDÆ. Finches, Sparrows, Etc.

Genus CARPODACUS Kaup.

154. (517). *C. purpureus* (Gmel.). Purple Finch. Transient, and winter visitor throughout the State, sometimes very common. At Chapel Hill, in the spring of 1887, hundreds remained on the University grounds for a month or more, associated with numbers of *Spinus tristis*, and feeding on the buds and tender seeds of the elm. Brewster reported it abundant at Old Fort, and thinks it breeds there. (Univ. Coll.).

Genus LOXIA Linnæus.

155. (521). *L. curvirostra minor* (Brehm.). American Cross-bill. Small flocks on Black Mountains, above 5,000 feet; said to appear at Highlands in winter regularly (*vide* Brewster). Rare transient at Raleigh (Brimley).

Genus SPINUS Koch.

*156. (529). *S. tristis* (Linn.). American Goldfinch. Resident in middle and mountain regions; abundant especially in winter. In August I found it abundant at Balsam Station. (Univ. Coll.).

157. (533). *S. pinus* (Wils.). Pine Siskin. Mountain region, common transient, and rare winter visitor (*vide* Cairns); Black Mountains June 2d, 1886 (*vide* Brewster); middle region, sometimes common in winter (Brimley).

Genus POOCLETES Baird.

158. (540). *P. gramineus* (Gmel.). Vesper Sparrow. Common during winter in middle and mountain regions. Cairns says rather common in Buncombe county in summer. (Univ. Coll.).

Genus AMMODRAMUS Swainson.

Subgenus PASSERCULUS Bonaparte.

159. (542a). *A. sandwichensis savanna* (Wils.). Savanna Sparrow. Winter visitor, middle region, rather common. (Priv. Coll.).

Subgenus COTURNICULUS Bonaparte.

*160. (546). *A. savannarum passerinus* (Wils.). Grasshopper Sparrow. Common during summer near Franklin in mountain region and apparently breeding (*vide* Brewster). Rare transient eastward.

Genus ZONOTRICHIA Swainson.

161. (554). *Z. leucophrys* (Forst.). White-crowned Sparrow. Accidental at Raleigh. (Coll. of James Busbee).

162. (558). *Z. albicollis* (Gmel.). White-throated Sparrow. Common winter visitor throughout the State. (Univ. Coll.).

Genus SPIZELLA Bonaparte.

*163. (560). *S. socialis* (Wils.). Chipping Sparrow. Summer visitor, common, and generally distributed. (Univ. Coll.).

164. (561). *S. pallida* (Swains.). Clay-colored Sparrow. Accidental. One taken at Chapel Hill, March 8th, 1886. (Univ. Coll.).

*165. (563). *S. pusilla* (Wils.). Field Sparrow. Common resident, and generally distributed. (Univ. Coll.).

Genus PASSER Brisson.

*166. (—). *P. domesticus* (Linn.). Abundant in towns and villages. (Univ. Coll.).

Genus JUNCO Wagler.

167. (567). *J. hyemalis* (Linn.). Slate-colored Junco. Common winter visitor throughout the State. (Univ. Coll.).

*168. (567b). *J. hyemalis carolinensis* Brewst. Carolina Junco. Found by Brewster in summer only on Black Mountains, and at Highlands above elevation of 4,300 feet. Nests collected at the latter place. Found in winter by Batchelder associated with *J. hyemalis* in valleys.

Genus PEUCÆA Audubon.

*169. (575a). *P. aestivalis bachmanii* (Aud.). Bachman's Sparrow. Rare summer visitor. Single specimen taken by Brewster at Franklin. A few taken in March and April, '85 and '87, at Raleigh by Brimley. One taken from a breeding pair by myself at Chapel Hill. The nest was found by Willie Gulick; eggs 4, size .63 x .76, dull whitish; nest a bulky structure on the ground made of coarse grasses. I believe the nest and eggs have never before been described. (Univ. Coll.).

Genus MELOSPIZA Baird.

170. (581). *M. fasciata* (Gmel.). Song Sparrow. Common winter visitor. (Univ. Coll.).

171. (584). *M. georgiana* (Lath.). Swamp Sparrow. Common transient in mountain region, winter visitor in middle region.

Genus PASSERELLA Swainson.

172. (585). *P. iliaca* (Merr.). Fox Sparrow. Common winter visitor. (Univ. Coll.).

Genus PIPILO Vieillot.

173. (587). *P. erythrophthalmus* (Linn.). Towhee. Common transient in middle region, common resident in mountain region, and winters in coast region. Probably breeds in mountain region. (Univ. Coll.).

Genus CARDINALIS Bonaparte.

*174. (593). *C. cardinalis* (Linn.). Cardinal. Generally distributed, common, resident; lower valleys in mountain region. Called also "Cardinal Grosbeak," "Winter Redbird," etc. (Univ. Coll.).

Genus HABIA Reichenbach.

175. (595). *H. ludoviciana* (Linn.). Rose-breasted Grosbeak. Rare transient in middle region. Summer sojourner on high mountains, range from 3,800 feet to 5,000 feet on Black Mountains, and 3,500 feet to 4,500 feet at Highlands (*vide* Brewster); Craggy Mountain (*vide* Cairns). Probably breeds. (Univ. Coll.).

Genus GUIRACA Swainson.

*176. (597). *G. caerulea* (Linn.). Blue Grosbeak. Rather common summer sojourner in middle region, where it breeds. Single specimen seen at Asheville by Brewster. (Univ. Coll.).

Genus PASSERINA Vieillot.

*177. (598). *P. cyanea* (Linn.). Common summer visitor, generally distributed; in mountain region below 4,500 feet. (Univ. Coll.).

178. (601). *P. ciris* (Linn.). Painted Bunting. Summer visitor Beaufort, (Brimley).

Family TANAGRIDÆ. Tanagers.

Genus PIRANGA Vieillot.

*179. (608). *P. erythromelas* Vieill. Scarlet Tanager. Spring and autumn transient in middle region, rare. Summer sojourner

in mountain region, abundant in hard wood timber of Black Mountain up to 500 feet (*vide* Brewster, Cairns). It probably breeds in mountain region. I took a young male at Balsam Station in August, 1887, and saw several others. Two young males and one female taken at Chapel Hill in September, 1887. Both males with black wings and tail, female with wings and tail dark ash. One male with black spots on crown and scapulars, and faint tinge of reddish on interscapulars and tips of upper tail coverts. Otherwise both males rich olive green on upper parts, and rich greenish yellow on lower parts. (Univ. Coll.).

*180. (610). *P. rubra* (Linn.). Summer Tanager. Summer visitor, generally distributed, rather rare and local in mountain region. Seems to breed numerously in middle region. Two females were taken at Chapel Hill parti-male-colored; one taken from a nest was olive-yellow below, olive-green above; heavily washed on entire under parts, neck, lesser wing-coverts, tail-feathers, back, except interscapulars and rump, with red; crown, interscapulars, rump and wings only slightly tinged with reddish. (Univ. Coll.).

Family HIRUNDINIDÆ. Swallows.

Genus PROGNE Boie.

*181. (611). *P. subis* (Linn.). Purple Martin. Summer visitor, rather rare, but sometimes common in localities, usually towns and villages.

Genus PETROCHELIDON Cabanis.

182. (612). *P. lunifrons* (Say). Cliff Swallow. Rare transient in mountain region (*vide* Cairns).

Genus CHELIDON Forster.

183. (613). *C. erythrogaster* (Bodd.). Barn Swallow. Rather rare transient.

Genus TACHYCINETA Cabanis.

184. (614). *T. bicolor* (Vieill.). White-bellied Swallow. Rather common transient in middle and coast region.

Genus STELGIDOPTERYX Baird.

*185. (617). *S. serripennis* (And.). Rough-winged Swallow. Common summer sojourner, generally distributed. Settled portions of mountain region up to 2,500 feet, nesting in ledges and clay banks (*vide* Brewster). (Univ. Coll.).

Family AMPELIDÆ. Waxwings, Etc.

Genus AMPELIS Linnæus.

*186. (619). *A. cedrorum* (Vieill.). Cedar Waxwing. Common resident, generally distributed, very common in flocks in winter, rather uncertain and irregular in localities. On Black Mountains a pair preparing to breed at altitude of 5,000 feet (*vide* Brewster). (Univ. Coll.).

Family LANIIDÆ. Shrikes.

Genus LANIUS Linnæus.

187. (622). *L. ludovicianus* Linn. Loggerhead Shrike. Rather rare winter visitor in middle region. (Univ. Coll.).

Family VIREONIDÆ. Vireos.

Genus VIREO Vieillot.

Subgenus VIREOSYLVA Bonaparte.

*188. (624). *V. olivaceus* (Linn.). Red-eyed Vireo. Common summer visitor, generally distributed, in mountain region below 4,000 feet. (Univ. Coll.).

189. (626). *V. philadelphicus* (Cass.). Philadelphia Vireo. Rare transient in mountain region (*vide* Cairns).

190. (627). *V. gilvus* (Vieill.). Warbling Vireo. Rare summer visitor, mountain region (Old Fort and Buncombe county, *vide* Brewster and Cairns).

Subgenus LANIVIREO Baird.

191. (628). *V. flavifrons* Vieill. Yellow-throated Vireo. Summer visitor, rather common in middle and mountain region. (Univ. Coll.).

192. (629). *V. solitarius* (Wils.). Blue-headed Vireo. Rather common transient in middle and mountain regions, and rare summer visitor in latter place.

193. (—). *V. solitarius alticola* Brewst. Mountain Solitary Vireo. Mountain region, some places common, in oak and chestnut woods ranging from 4,200 feet to foot of the balsams, 5,000 feet (*vide* Brewster).

Subgenus VIREO Vieillot.

194. (631). *V. noveboracensis* (Gmel.). White-eyed Vireo. Rather rare summer visitor, generally distributed. (Univ. Coll.).

Family MNIOTILTIDÆ. Wood Warblers.

Genus MNIOTILTA Vieillot.

*195. (636.) *M. varia* (Linn.). Black and White Warbler. Common summer visitor, generally distributed. (Univ. Coll.).

Genus PROTONOTARIA Baird.

196. (637). *P. citrea* (Bodd.). Prothonotary Warbler. Rare summer visitor, middle region (Brimley).

Genus HELINAIA Audubon.

197. (638). *H. swainsonii* Aud. Swainson's Warbler. One taken at New Bern April 13, 1885, by H. H. Brimley. First record of its occurrence in North Carolina.

Genus HELMITHERUS Rafinesque.

198. (639). *H. vermivorus* (Gmel.). Worm-eating Warbler. Rather rare transient in middle region, rare summer visitor in mountain region. (Univ. Coll.).

Genus HELMINTHOPHILA Ridgway.

199. (641). *H. pinus* (Linn.). Blue-winged Warbler. Rare summer visitor in mountain region (Craggy Mount, Cairns).

*200. (642). *H. chrysoptera* (Linn.). Golden-winged Warbler. One taken by Brimley near Raleigh August 26, 1886. Rare summer visitor in mountain region (eggs taken by Cairns at foot of Craggy Mount June 2, 1885). Brewster found it common in Jackson and Macon counties, ranging from 2,000 feet to 4,000 feet in open oak woodland.

201. (645). *H. ruficapilla* (Wils.). Nashville Warbler. Rare transient in mountain region (*vide* Cairns).

202. (647). *H. peregrina* (Wils.). Tennessee Warbler. Rare transient, middle and mountain regions (Brimley and Cairns).

Genus COMPSOTHLYPIS Cabanis.

*203. (648). *C. americana* (Linn.). Parula Warbler. Common summer visitor throughout the State. (Univ. Coll.). Called also "Blue Yellow-backed Warbler."

Genus DENDROICA Gray.

Subgenus PERISSOGLOSSA Baird.

204. (650). *D. tigrina* (Gmel.). Cape May Warbler. Rare transient in Buncombe county (*vide* Cairns).

Subgenus DENDROICA Gray.

*205. (652). *D. aestiva* (Gmel.). Yellow Warbler. Common summer visitor, generally distributed; in mountain region below 2,800 feet, along streams (*vide* Brewster). (Univ. Coll.).

*206. (654). *D. carulescens* (Gmel.). Black-throated Blue Warbler. Common transient in middle, and also sojourner in mountain region; Brewster found it abundant at Highlands in Rhododendron swamps and along Rhododendron bordered streams of Black Mountains, says it probably breeds. (Univ. Coll.).

207. (655). *D. coronata* (Linn.). Myrtle Warbler. Common winter visitor throughout the State, sometimes appearing in large flocks. (Univ. Coll.). "Yellow-rumped Warbler."

208. (657). *D. maculosa* (Gmel.). Magnolia Warbler. Rather rare transient in middle, and more common in mountain region. (Univ. Coll.).

209. (658). *D. caerulea* (Wils.). Cærulean Warbler. Rare transient in middle and mountain region.

*210. (659). *D. pensylvanica* (Linn.). Chestnut-sided Warbler. Rather rare transient in middle, and common summer sojourner in mountain region, where it is generally distributed 2,000 feet to 4,000 feet (*vide* Brewster). I took a pair at Balsam Station in August, 1887; probably breeds. (Priv. Coll.).

211. (661). *D. striata* (Forst.). Black-poll Warbler. Rather rare transient visitor in middle and coast region. (Coll. of 1877).

*212. (662). *D. blackburniae* (Gmel.). Blackburnian Warbler. Middle and mountain region, transient in former and summer sojourner in latter, where it is somewhat irregularly distributed; rare in Buncombe county (Cairns); Jackson and Macon counties abundant everywhere above 3,000 feet, and on crest of Cowee range, and about Highlands the commonest of birds; evidently breeding (Brewster).

*213. (663). *D. dominica* (Linn.). Yellow-throated Warbler. Summer visitor, generally distributed, rather rare. (Univ. Coll.).

*214. (667). *D. virens* (Gmel.). Black-throated Green Warbler. Rare transient throughout the State except on Black Mountains, where Brewster found it abundant in the balsam forests above 5,000 feet; he says it probably breeds.

*215. (671). *D. vigorsii* (Aud.). Pine Warbler. Common resident in middle and coast regions, rare resident in mountain region, but common as a transient. (Univ. Coll.).

216. (672). *D. palmarum* (Gmel.). Palm Warbler. Rather rare transient and winter visitor. (Univ. Coll.).

*217. (673). *D. discolor* (Vieill.). Prairie Warbler. Rather common summer visitor in middle region. Brewster found it common at Old Fort. (Univ. Coll.).

Genus SEIURUS Swainson.

218. (674). *S. aurocapillus* (Linn.). Oven-bird. Common transient in middle region, and common summer sojourner in mountain region. (Univ. Coll.).

219. (675). *S. noveboracensis* (Gmel.). Water-Thrush. Rather common transient in middle region, and rare summer visitor in mountain region (*S. naxius*, vide Cairns). (Univ. Coll.).

*220. (676). *S. motacilla* (Vieill.). Louisiana Water-Thrush. Rare summer visitor in middle and mountain region.

Genus GEOTHLYPIS Cabanis.

Subgenus OPORORNIS Baird.

221. (677). *G. formosa* (Wils.). Kentucky Warbler. Summer visitor, rare in middle region, rather common in mountain

region, where it is generally distributed in valleys and up mountain sides to 3,500 feet.

222. (678). *G. agilis* (Wils.). Connecticut Warbler. Taken at Raleigh by Brimley October 15, 1884.

Subgenus GEOTHLYPIS Cabanis.

*223. (681). *G. trichas* (Linn.). Maryland Yellow-throat. Summer visitor, rather common throughout the State. (Univ. Coll.).

Genus ICTERIA Vieillot.

*224. (683). *I. virens* (Linn.). Yellow-breasted Chat. Everywhere abundant, summer sojourner. (Univ. Coll.).

Genus SYLVANIA Nuttall.

225. (684). *S. mitrata* (Gmel.). Hooded Warbler. Rare transient throughout the State, and rare summer sojourner in mountain region, where it is generally distributed in "Rhododendron thickets along streams, ranging to 3,800 feet" (*vide* Brewster). (Univ. Coll.).

226. (685). *S. pusilla* (Wils.). Wilson's Warbler. Rare transient (Busbee and Cairns).

*227. (686). *S. canadensis* (Linn.). Canadian Warbler. Summer sojourner in mountain region. "Abundant from 3,000 feet to tops of highest mountains; breeds at Highlands" (Brewster).

Genus SETOPHAGA Swainson.

*228. (687). *S. ruticilla* (Linn.). American Redstart. Common transient and rather rare summer sojourner in middle and mountain regions. (Univ. Coll.).

Family MOTACILLIDÆ. Wagtails.

Genus ANTHUS Bechstein.

Subgenus ANTHUS.

229. (697). *A. pensilvanicus* (Lath.). American Pipit. Winter visitor in middle and coast region, irregularly distributed; rare transient in Buncombe county (*vide* Cairns).

Family TROGLODYTIDÆ. Wrens, Thrashers, Etc.

Genus MIMUS Boie.

*230. (703). *M. polyglottis* (Linn.). Mockingbird. Rare and local summer visitor in mountain region, where it breeds sparingly; abundant resident and breeder in middle and coast region. (Univ. Coll.).

Genus GALEOSOPTES Cabanis.

*231. (704). *G. carolinensis* (Linn.). Catbird. Common summer visitor throughout the State. Winters in portions of coast region. (Univ. Coll.).

Genus HARPORHYNCHUS Cabanis.

Subgenus METHRIOPTERUS Reichenbach.

*232. (705). *H. rufus* (Linn.). Brown Thrasher. Rather common summer visitor. (Univ. Coll.).

Genus THRYOTHORUS Vieillot.

Subgenus THRYOTHORUS.

*233. (718). *T. ludovicianus* (Lath.). Carolina Wren. Common resident in entire State, breeding throughout its range. (Univ. Coll.).

Subgenus THRYOMANES Selater.

*234. (719). *T. bewickii* (Aud.). Bewick's Wren. Resident in mountain region, rather common in summer in towns, breeds in sheds and out-buildings (*vide* Brewster).

Genus TROGLODYTES Vieillot.

Subgenus TROGLODYTES.

235. (721). *T. aedon* Vieill. House Wren. Rare transient. (Univ. Coll.).

Subgenus ANORTHURA Rennie.

236. (722). *T. hiemalis* Vieill. Winter Wren. Rather rare winter visitor in middle region; resident in mountain region; "abundant in balsams of Black Mountains 5,000 feet to 6,000 feet (*vide* Brewster). (Univ. Coll.).

Genus CISTOTHORUS Cabanis.

Subgenus CISTOTHORUS.

237. (724). *C. stellaris* (Licht.). Short-billed Marsh Wren. Rare transient, Buncombe county (*vide* Cairns).

Subgenus TELMATODYTES Cabanis.

238. (725). *C. palustris* (Wils.). Long-billed Marsh Wren. Rare transient, taken at Raleigh in April and May, 1886 (Brimley).

Family CERTHIIDÆ. Creepers.

Genus CERTHIA Linnæus.

*239. (726). *C. familiaris americana* (Bonap.). Brown Creeper. Common winter visitor and transient in middle region; resident in mountain region, common in winter, abundant transient, and rare in summer. "Common at Highlands and Black Mountains, in balsams, above 4,000 feet, breeds" (*vide* Brewster). (Univ. Coll.).

Family PARIDÆ. Nuthatches and Tits.

Genus SITTA Linnæus.

*240. (727). *S. carolinensis* Lath. White-breasted Nuthatch. Rather common resident throughout the State. (Univ. Coll.).

*241. (728). *S. canadensis* Linn. Red-breasted Nuthatch. Rare winter visitor in middle region; rare summer visitor in mountain region. In balsams of Black Mountains from 5,000 feet to 6,000 feet, breeds (Brewster).

*242. (729). *S. pusilla* Lath. Brown-headed Nuthatch. Rather common resident in middle and coast regions; rather local.

Genus PARUS Linnæus.

Subgenus LOPHOPHANES Kaup.

*243. (731). *P. bicolor* Linn. Tufted Titmouse. Common resident, generally distributed. (Univ. Coll.).

Subgenus PARUS Linnæus.

*244. (735). *P. atricapillus* Linn. Chickadee. Rather common resident in mountain region, breeds (*vide* Brewster and Batchelder).

*245. (736). *P. carolinensis* Aud. Carolina Chickadee. Common resident throughout the State. (Univ. Coll.).

Family SYLVIIDÆ. Warblers, Kinglets and Gnatcatchers.

Genus REGULUS Cuvier.

246. (748). *R. satrapa* Licht. Golden-crowned Kinglet. Rather common winter visitor in all parts of the State; in summer balsams of Black Mountains (*vide* Brewster). Probably breeds, and is a resident in mountain region. (Univ. Coll.).

247. (749). *R. calendula* (Linn.). Ruby-crowned Kinglet. Rare transient in mountain region; rather common winter visitor in middle and coast regions.

Genus POLIOPTILA Sclater.

*248. (751). *P. cerulea* (Linn.). Blue-gray Gnatcatcher. Common summer visitor. (Univ. Coll.).

Family TURDIDÆ. Thrushes, Solitaires, Stonechats, Bluebirds, Etc.

Genus TURDUS Linnæus.

Subgenus HYLOCICHLA Baird.

*249. (755). *T. mustelinus* Gmel. Wood Thrush. Abundant throughout the State, breeds everywhere. (Univ. Coll.).

*250. (756). *T. fuscescens* Steph. Wilson's Thrush. Rare transient in middle region; summer visitor in mountain region; Craggy Mountain (Cairns); abundant on Black Mountains and at Highlands from 3,500 to 5,000 feet; breeds at Highlands (*vide* Brewster). (Univ. Coll.).

251. (757a). *T. alicie bicknelli* (Ridgw.). Bicknell's Thrush. Rare transient near Raleigh (Brimley).

252. (758a). *T. ustulatus swainsonii* (Cab.). Olive-backed Thrush. Rather common transient visitor in middle region; summer visitor in mountain region; "common on Craggy Mountain" (*vide* Cairns). Does it breed? (Univ. Coll.).

253. (759b). *T. aonataschkæ pallasii* (Cab.). Hermit Thrush. Rather common winter visitor throughout the State. (Univ. Coll.).

Genus MERULA Leach.

*254. (761). *M. migratoria* (Linn.). American Robin. Rather common resident, sometimes sparingly in localities, abundant during spring and autumn migrations. (Univ. Coll.).

Genus SIALIA Swainson.

*255. (766). *S. sialis* (Linn.). Bluebird. Common resident. (Univ. Coll.).

APPENDIX.

(CONTAINING A LIST OF BIRDS WHICH WE MAY REASONABLY
EXPECT TO YET TAKE IN THE STATE).

-
1. (36). *Stercorarius pomarinus* (Temm.). Pomarine Jaeger.
 2. (37). *Stercorarius parasiticus* (Linn.). Parasitic Jaeger.
 3. (38). *Stercorarius longicaudus* Vieill. Long-tailed Jaeger.
 4. (59). *Larus franklinii* Sw. & Rich. Franklin's Gull.
 5. (63). *Gelochelidon nilotica* (Hasselq.). Gull-billed Tern.
 6. (64). *Sterna tschegrava* Lepech. Caspian Tern.
 7. (67). " *sandvicensis acyflavida* (Cabot). Cabot's Tern.
 8. (71). " *paradiscea* Brünn. Arctic Tern.
 9. (72). " *dougalli* Montag. Roseate Tern.
 10. (79). *Anous stolidus* (Linn.). Noddy.
 11. (89). *Puffinus major* Faber. Greater Shearwater.
 12. (92). " *auduboni* Finsch. Audubon's Shearwater.
 13. (94). " *stricklandi* Ridgw. Sooty Shearwater.
 14. (106). *Oceanodroma leucorpoa* Vieill. Leach's Petrel.
 15. (109). *Oceanites oceanicus* (Kuhl). Wilson's Petrel.
 16. (115). *Sula sula* (Linn.). Boobey.
 17. (117). " *bassana* (Linn.). Gannet.
 18. (118). *Anhinga anhinga* (Linn.). Anhinga.
 19. (119). *Phalacrocorax carbo* (Linn.). Cormorant.
 20. (120). " *dilophus floridanus* (Aud.). Florida
Cormorant.
 21. (126). *Pelecanus fuscus* Linn. Brown Pelican.
 22. (128). *Fregata aquila* (Linn.). Man-o'-War Bird.
 23. (172a). *Branta canadensis hutchinsii* (Sw. & Rich.).
Hutchins' Goose.
 24. (174). *Branta nigricans* (Larr.). Black Brant.
 25. (181). *Olor buccinator* (Rich.). Trumpeter Swan.
 26. (183). *Ajaja ajaja* (Linn.). Roseate Spoonbill.
 27. (184). *Guara alba* (Linn.). White Ibis.

28. (186). *Plegadis autumnalis* (Hassalq.). Glossy Ibis.
29. (202). *Nycticorax nycticorax naevius* (Bodd.). Black-crowned Night Heron.
30. (204). *Grus americana* (Linn.) Whooping Crane.
31. (206). “ *mexicana* (Müll.). Sandhill Crane.
32. (216). *Porzana jamaicensis* (Gmel.). Black Rail.
33. (223). *Phalaropus lobatus* (Linn.). Northern Phalarope.
34. (224). “ *tricolor* (Vieill.). Wilson’s Phalarope.
35. (225). *Recurvirostra americana* Gmel. American Avocet.
36. (226). *Himantopus mexicanus* (Müll.). Black-necked Stilt.
37. (233). *Micropalama himantopus* (Bonap.). Stilt Sandpiper.
38. (234). *Tringa canutus* Linn. Knot.
39. (235). “ *maritima* Brünn. Purple Sandpiper.
40. (240). “ *fuscicollis* Vieill. White-rumped Sandpiper.
41. (241). “ *bairdii* (Coues). Baird’s Sandpiper.
42. (246). *Ereunetes pusillus* (Linn.). Semipalmated Sandpiper.
43. (247). *Ereunetes occidentalis* Lawr. Western Sandpiper.
44. (249). *Limosa fedoa* (Linn.). Marbled Godwit.
45. (251). “ *hemastica* (Linn.). Hudsonian Godwit.
46. (262). *Tringites subruficollis* (Vieill.). Buff-breasted Sandpiper.
47. (265). *Numenius hudsonicus* Lath. Hudsonian Curlew.
48. (266). “ *borealis* (Forst.). Eskimo Curlew.
49. (277). *Egialitis meloda* (Ord.). Piping Plover.
50. (280). “ *wilsonia* (Ord.). Wilson’s Plover.
51. (286). *Hematopus palliatus* Temm. American Oyster Catcher.
52. (320). *Columbigallina passerina* (Linn.). Ground Dove.
53. (328). *Elanus leucurus* (Vieill.). White-tailed Kite.
54. (329). *Ictinia mississippiensis* (Wils.). Mississippi Kite.
55. (347). *Archibuteo lagopus* (Brünn.). Rough-legged Hawk.
56. (365). *Strix pratincola* Bonap. American Barn Owl.
57. (372). *Nyctala acadica* (Gmel.). Saw-Whet Owl.

58. (376). *Nyctea nyctea* (Linn.). Snowy Owl.
59. (445). *Tyrannus dominicensis* (Gmel.). Gray Kingbird.
60. (463). *Empidonax flaviventris* Baird. Yellow-bellied Flycatcher.
61. (466a). *Empidonax pusillus trailii* (Aud.). Traill's Flycatcher.
62. (511b). *Quiscalus quiscula aeneus* (Ridgw.). Bronzed Grackle.
63. (534). *Plectrophenax nivalis* (Linn.). Snowflake.
64. (536). *Calcarius lapponicus* (Linn.). Lapland Longspur.
65. (541). *Ammodramus princeps* (Mayn.). Ipswich Sparrow.
66. (547). " *henslowii* (Aud.). Henslow's Sparrow.
67. (548). " *leconteii* (Aud.). Leconte's Sparrow.
68. (549). " *caudacutus* (Gmel.). Sharped-tailed Sparrow.
69. (549a). " " *nelsoni* Allen. Nelson's Sparrow.
70. (550). " *maritimus* (Wils.). Seaside Sparrow.
71. (559). *Spizella monticola* (Gmel.). Tree Sparrow.
72. (583). *Melospiza lincolni* (Aud.). Lincoln's Sparrow.
73. (604). *Spiza americana* (Gmel.). Dickeissel.
74. (612). *Petrochelidon lunifrons* (Say). Cliff Swallow.
75. (616). *Clivicola riparia* (Linn.). Bank Swallow.
76. (646). *Helminthophila celata* (Say). Orange-crowned Warbler.
77. (660). *Dendroica castanea* (Wils.). Bay-breasted Warbler.
78. (670). " *kirtlandi* Baird. Kirtland's Warbler.
79. (672a). " *palmarum hypochrysea* Ridgw. Yellow Palm Warbler.
80. (679). *Geothlypis philadelphia* (Wils.). Mourning Warbler.
81. (757). *Turdus aliciae* Baird. Gray-cheeked Thrush.

No. VII.

SINGULAR ADAPTATION IN NEST-MAKING BY AN
ANT, *CREMASTOGASTER LINEOLATA** SAY.[See plate at back of Journal.]

GEORGE F. ATKINSON.

A month ago I received an ant's nest, sent by Assistant Engineer Henry A. Brown to General W. Lewis, of Goldsboro, N. C. The nest was built several feet from the ground on a bush, in the marshes bordering Broad creek, Hyde county, N. C.

This ant usually nests "under stones or underneath and within the decayed matter of old logs and stumps. This material is sometimes prepared by the ant as a paper-like pulp, and arranged into cells and chambers, which are attached to the surface of the logs."†

This nest is about eighteen inches long by twelve inches in circumference at greatest diameter. I made a longitudinal section of it, and had a photograph taken, so as to represent both the external form and internal structure. The ants were alive in the nest when I received it. They were chloroformed before sectioning the nest. I took from the nest about one-fourth pint of adults, pupæ, and larvæ. They were collected in a mass through the chambers within a space four inches in length of the nest. This space is about two-thirds the distance from the lower end. The material composing the cells in this space is lighter in color than the other internal parts. It appeared also in the photograph, as can be seen by looking at the right-hand figure. Probably it will be visible in the photoengraving.

The material used in making the nest seems to be the same used by the ant in making its nest under stones, etc. Beside the woody pulp, a microscopic examination seems to reveal also

*The ant was determined for me through the kindness of Prof. C. V. Riley.

†Comstock's Report on Cotton Insects, 1879, p. 188.

some portions of dried grass. The nest is supported by the branches of the bush; a vine and some stalks of marsh-grass are fastened in it. Upon the outside the material is of a light gray color, much like that of the nest of the white-faced hornet. In the interior it is darker, in some places almost black. Probably the high tides causing the creek to overflow forced the ants to build their nest above the high-water mark instead of under stones and within logs. One cannot help thinking that possibly some species of Hymenoptera, which now altogether build elevated nests, once built them near the ground, and being forced for a long time by conditions surrounding them, similar to these, finally acquired that habit permanently.

This would seem more plausible if General Lewis is correct in a fact which he states, that the yellow-jackets along Holly creek, in Pender county, build nests on the bushes to avoid the tide. I mean to investigate this and see if they are the same species which under ordinary circumstances build nests in the ground.

No. VIII.

A REMARKABLE CASE OF PHOSPHORESCENCE IN
AN EARTH-WORM.

[See plate at back of Journal.]

GEORGE F. ATKINSON.

On the night of June 20, 1887, when returning from placing some *Phengodes* females where they might attract the males, I saw in the path before me a small phosphorescent light. As I approached it became larger; now an inch, and the next moment two inches long. I was on the point of declaring I had found another *Phengodes* when suddenly it became three, four, and six inches long, now darting in this direction and then in that.

Thinking there might be an insect capable of running and giving a phosphorescent light to objects in its path in such a way as to cause them to be illuminated for a short time, I struck a match so that I might see to capture it. As the light of the match overcame the phosphorescence and lighted up the objects on the ground, the only insect I saw was a Myriapod scampering away under the leaves. All this took place in less time than it takes to tell it. Thinking the insect was hidden under the leaves, when the light of the match was extinguished I began to brush them away with my hand. The phosphorescence appeared again, and the light advanced as rapidly as I moved my hand. I thought certainly I was in pursuit of the prize, and in my anxiety to capture it I would catch up a whole handful of earth. But I always noticed that I left the phosphorescent light on the ground. The insect eluded me, I thought. After pursuing the phantom in vain for some time, I stopped to ponder. After the habit of a puzzled man in an inquiring mood, I brushed my foot across the earth before me, when lo! each little pebble and pellet of earth bristled with a phosphorescent light. For a moment I seemed to lose confidence in the fact that all such phenomena are due to natural causes. The air was sparkling with fire-flies, and the earth at my feet was bristling with phosphorescence. Had time sped backward twenty centuries, and were the vestal fires lighting around me? Or was some great calamity impending? I seemed to hear these words repeated from the sky: "*Nate dea, quo fata trahunt retrahuntque, sequamur; Quidquid erit superanda omnis fortuna ferendo est.*" But in a moment more I had brushed away these delightful superstitions, and went to work to find the *cause*.

Taking a quantity of the earth, I went to my study. First I took several pebbles into a dark room and rubbed them in my hands; no light appeared. Then I took some pellets of earth and treated them in like manner; result the same. Surely, I thought, the phantom lies in these decaying leaves, but disappointment was also the result of the third investigation. I returned to my package of earth, and saw a lone earth-worm

writhing in pain. "I will try him," I thought. I took it into the dark room. It showed no sign of phosphorescence. I rolled it once across my hand. The *phantom* became *real*. Not only was the whole body of the earth-worm luminous, but the entire palm of my hand was aglow with phosphorescence. I made several trips to the place and secured other worms which exhibited the same peculiarity.

Probably the Myriapod which I saw had pounced upon one of these worms for a meal. It became phosphorescent, which may have frightened the Myriapod, and it ran, dragging its prey, and the worm's body touching the ground illuminated it, thus attracting my attention. When the earth is disturbed, the friction of the body against the particles gives phosphorescence to them. The earth-worm is probably a species of Lumbricidæ.

Professor Forbes, of Champaign, Ill., has kindly sent me an extract from "*System und Morphologie der Oligochaeten*; von Dr. Franz Vejdovsky, p. 67, 1884,"* from which I make the following abbreviated translation:

It appears probable that this remarkable phenomenon lies in a substance secreted by glands of the skin. The phosphorescence of earth-worms has been repeatedly observed. The first publication thereupon was by Grimm in 1670; and later by Flaugergues in Lichtenberg's Magazine (1781).† In the present century Cohn published some observations.‡ *A. Della Valle, Panceri, Siechi* and *Phipson* have each undertaken researches upon this subject. Panceri§ declares that the phosphorescence of earth-worms lies in single glands upon the surface of the body, and that the elevation of the temperature produces the phosphorescent light. Siechi|| found by spectroscopic analysis that the phosphorescent light is not monochromatic, but is made up of red and violet rays. Phipson¶ traced the production of the light in animals to a homogeneous substance (*noctilucin*) which seems to possess the power of oxidation when in contact with damp air.

*Ueber die Phosphorescenz der Regenwürmer.

†Ueber das phosphorische Licht der Erdwürmer.

‡Ueber die Phosphorescenz der Regenwürmer, z. f. vs. z. 1873, p. 459—461.

§Etudes sur la phosph. des animaux marins, Ann. Sc. Nat. 1872. T. XVI.

||*Ibid.*

¶Compte Rendues, 1872. p. 548

No. IX.

OBSERVATIONS ON THE FEMALE FORM OF
PHENGODES LATICOLLIS HORN.[See plate at back of Journal].

GEORGE F. ATKINSON.

Entomologists will remember the interest taken, about one year ago, in the discovery that the female form of a Lampyrid* (*Zarhipis riversi*) was larva-like, and that the three stages—larva, pupa, and adult—differed but little. On the night of September 27, 1886, a larviform, luminous beetle was collected on one of the walks of the campus of the University of North Carolina.

Pupa State.—As the insect cast its skin only once—in the spring of 1887—after coming into my possession, this must represent its pupa state.

Description.—Length when crawling, two and three-fourths inches; width, three-eighths inch. Flattened, larviform, luminous; composed of twelve segments (exclusive of the head), tapering gently behind, and more decidedly on the three anterior segments. Chitinous plates on dorsum blackish-brown, the second to eleventh inclusive with a pair of large, light-brown, oval spots. Anal plate light-brown, except a median band of blackish-brown, convex behind. First plate light-brown, except a median irregular and two lateral blackish-brown spots. Below each stigmata, on the fourth to eleventh segments inclusive, are two longitudinal folds, the anterior half of each fold blackish-brown, shading into light-brown in the middle, and becoming yellowish-white, with an olive tinge on the posterior half. Posterior edge of each dorsal plate dark olive-brown; the posterior angles of the pro-, meso-, and meta-thoracic plate and the anterior third of the prothoracic plate yellowish-white, tinged with olive. On the fifth

*Am. Nat., xx, 648. See also, Ent. Am., iii, 203.

to ninth segments inclusive (ventral surface) are one pair each of small, elongated, black dots, corresponding very nearly in position with the pairs of luminous organs of the ventral surface. Anal proleg blackish-brown above, yellowish-white below.

Besides the stigmata on the fourth to eleventh segments, there is one on the ventral surface of each anterior corner of the mesothoracic segment; also two pairs of small dorsal spiracles, one each between the fourth and fifth, and fifth and sixth segments.

Thoracic legs brown, suffused with yellowish-olive. Tarsus two-jointed; single claw curved. Anterior edge of femur with a row of short hairs; under edge of tibia and first joint of tarsus with a similar row of hairs; under edge of last joint of tarsus with small, short papillæ. Head black, $2\frac{1}{2}$ mm. in width, retractile. Mandibles curved, sickle-shaped, black. Antennæ four-jointed: labial palpi two-jointed (or three-jointed? Those of a larva collected in July appear three-jointed): maxillary palpi four-jointed.

The location and form of the phosphorescent lights are as follows: On each side is a row of circular ones, one on each segment from the second to the twelfth inclusive. Each of these is nearly one-eighth inch in diameter, and situated in the posterior end of the upper longitudinal fold. The posterior edge of each segment, from the second to the twelfth inclusive, emits a band of light. On the under surface are five pairs mere points, one pair each on the fifth to ninth segments. The general appearance is that of a worm beautifully illuminated with bluish-white lights, which are disposed in a longitudinal row on each side, and in transverse bands.

The insect was placed in a small, elongated vial, so that I might easily observe and exhibit the display of lights. The light was brilliant until 11 P. M. on the night of September 27. At 2 A. M. on the 28th the phosphorescence had disappeared. It did not appear again until the night of the 30th, when, by disturbing the insect, the lights began to glow, but continued only for a few hours. For a few nights, within the space of a week, I observed that the insect glowed only when disturbed. After that

the phosphorescence re-appeared, and I do not believe once disappeared again until it was placed in alcohol, June 16, 1887.

October 1, 1886, I placed it in a glass jar of earth. It made a cell in the earth next the side of the jar, where I could observe the phosphorescence, and where it remained (excepting one warm day in February, 1887, when it came to the surface, and returned at night when I placed the jar in a cooler place in my room) coiled up until the 15th of April. At that time the luminosity was becoming more brilliant and the brown color was disappearing, to be replaced by a uniform cream color.

I removed the earth from above the cell and took the insect in my hand. It immediately straightened and began crawling. When placed in the jar it sought its cell and there remained. Instead of returning the earth I placed a glass over it, so that I might observe the beautiful display of light. It was so strong that I could read print by it when the letters were one-eighth inch long. About the 1st of May it cast its skin and became of a uniform cream color, lighter on the sides and ventral surface and between the segments of the dorsum.

Every night it came from its cell and wandered about the jar, probably striving to attract its mate. May 8 I took it out of doors at night, and placed it on the ground for about fifteen minutes. Nothing was attracted. Twice I took it in the daytime,—the 10th and 12th of May,—but nothing was attracted.

May 19 I placed it, with another (collected by Professor Holmes), in a large, open, glass jar, with about one inch in depth of earth. This I partly sunk in the earth in the open woods just at dusk. At nine o'clock the same evening I visited the place and saw a male within the jar. When it left its mate I caught it.* On the following morning I found another male outside the jar. The following night I captured two more males. During the day the females remained beneath the surface of the earth.

The luminosity in this case is decidedly of sexual significance, attracting the males at night. Mr. Rivers concluded that the

*Determined by Professor Riley as *Phengodes laticollis* Horn.

luminosity of the female *Zarhipis riversi* was not of sexual significance, as males were attracted by day. He was at a loss to account for its utility.

Soon after meeting with the males the females became less active, and the luminosity, though plainly visible, was less in brilliancy. About June 4 they made each a cell in the earth and began depositing eggs. One deposited about twenty, and the other about thirty-five. The eggs are dull whitish in color, 3 mm. to 4 mm. in diameter. This, I believe, is the first instance on record of the eggs of any of the *Phengodini*. The female is coiled up in the cell while depositing the eggs, and afterwards lies coiled up on them. They are then very weak, and soon die. Can it be that the parent yields its dying or dead body as the first meal for its young? One which was found in September, 1886, was taken from the eggs when nearly dead and placed in alcohol. The eggs of this one proved infertile. The mouth parts, and especially the legs, were very much atrophied, and description was well-nigh impossible. In general appearance the adult is very much like that of the larva and pupa. The two which I observed did not, however, resume the dark-brown color, but remained of an uniform pale-cream color, lighter on sides, under parts, and between the segments of the dorsum.

Occasionally during the adult state the one which I kept through the winter showed signs of luminosity on the pro-thoracic segment. The other one exhibited no sign of luminosity on the pro- and meso-thoracic segments. Professor Riley, some years ago, figured a similar phosphorescent insect, and in the paper, read before the Washington Entomological Society, he says that one found by him in 1869 was figured in Le Baron's fourth Illinois report.

The males are insignificant when compared to the females in size and beauty. They are 15 mm. to 20 mm. in length. Antennæ plumose, and half, or more than half, as long as the body. The elytra are short, thin, and subulate.

CONTRIBUTIONS FROM THE CHEMICAL LABORATORY OF THE UNIVERSITY OF N. C.
No. XXXIV.

ANALYSES OF NORTH CAROLINA WINES.

F. P. VENABLE AND W. B. PHILLIPS.

So far as we are aware no analyses of the wines produced in this State have ever been published. As the industry has grown greatly in the past few years and gives promise of still greater growth, it is manifestly of importance that these wines should be analyzed. A comparison is thus possible with the wines of other localities and our knowledge of the chemistry of wines increased. The wines were, in all, save one case, furnished us direct by the makers. Where we have learned of additions made to the fermented juice of the grape, note has been made of it in the table.

Of special interest are the analyses of wines made from the native Scuppernong vine and the closely related grapes—the Mish, or Meisch, and Bulay. The Scuppernong is very abundant, hardy and prolific in certain sections of the State, and the problem, of fermenting and blending, so as to secure a good wine from it is very important.

In the accompanying table will be found analyses of nineteen varieties of wine. The analyses were carried out according to the methods recommended by the German Commission of 1884 as recorded by Barth. The figures in the last nine columns represent percentages. The percentage of alcohol is given both by weight and by volume. The “extract” is that which is called generally the “body” of the wine and includes all of that portion which will not evaporate at 100°.

With regard to the volatile or acetic acid, the total acid was first determined then that which was left after evaporation on the water-bath. The method was carefully tested and found to be correct. The tannin was determined by comparison of the

depth of precipitate produced by ferric chloride after the addition of sodium acetate, with that produced in solutions of known strength. The extract was determined by evaporation on a water-bath followed by two and a half hours heating in the steam bath. As the temperature of the steam-bath generally lies between 95° and 97° the results thus obtained are high compared with those gotten by heating at 100° or 110° .

| VARIETY OF WINE. | MANUFACTURER'S ADDRESS. | | VINTAGE. | SPECIFIC GRAV. | ALCOHOL BY WEIGHT. | ALCOHOL BY VOLUME. | TARTAR. ACID. | ACET. ACID. | TOTAL ACID. | SUGAR. | TANNIN. | EXTRACT. | ASH. |
|-------------------------------|---|--|----------|----------------|--------------------|--------------------|---------------|-------------|-------------|--------|---------|----------|-------|
| | | | | Pret. | Pret. | Pret. | Pret. | Pret. | Pret. | Pret. | Pret. | Pret. | Pret. |
| Dry Mish..... | C. W. Garrett & Co., Medoc, N. C..... | | 1885 | 0.9957 | 9.51 | 11.81 | 0.655 | 0.044 | 0.699 | 0.60 | 0.020 | 3.162 | 0.122 |
| Dry Bulay..... | " " | | 1885 | 0.9951 | 8.38 | 10.40 | 0.818 | 0.031 | 0.849 | 0.45 | 0.015 | 2.179 | 0.113 |
| Dry Imperial Scuppernong..... | " " | | 1885 | 1.0009 | 9.37 | 11.62 | 0.770 | 0.022 | 0.792 | 2.20 | 0.025 | 4.259 | 0.106 |
| Dry Imperial Scuppernong..... | " " | | 1884 | 0.9919 | 9.36 | 11.61 | 0.713 | 0.055 | 0.765 | 0.08 | 0.025 | 2.597 | 0.110 |
| Dry Mish..... | " " | | 1884 | 0.9916 | 9.61 | 11.96 | 0.568 | 0.041 | 0.609 | 0.31 | 0.025 | 2.459 | 0.128 |
| Dry Black Scuppernong..... | " " | | 1886 | 0.9944 | 8.43 | 10.17 | 0.655 | 0.026 | 0.681 | 0.20 | 0.030 | 2.335 | 0.139 |
| Dry Norton..... | " " | | 1885 | 0.9965 | 9.14 | 11.35 | 0.724 | 0.011 | 0.765 | 0.25 | 0.025 | 2.785 | 0.224 |
| (Sweet) Scuppernong..... | " " | | 1884 | 1.0323 | 9.07 | 11.26 | 0.647 | 0.015 | 0.662 | 5.75 | 0.020 | 13.889 | 0.112 |
| (Sweet) Mish..... | " " | | 1885 | 1.0336 | 9.71 | 12.15 | 0.501 | 0.028 | 0.529 | 5.50 | 0.025 | 14.275 | 0.108 |
| (Sweet) Norton..... | " " | | 1885 | 1.0331 | 9.07 | 11.26 | 0.693 | 0.013 | 0.706 | 4.75 | 0.020 | 14.927 | 0.197 |
| King Grape..... | N. W. Craft, Shore, N. C..... | | 1885 | 0.9932 | 12.77 | 15.77 | 0.770 | | 0.770 | 1.75 | trace. | 3.320 | 0.173 |
| White Victory..... | " " | | 1885 | 1.0392 | 12.38 | 15.30 | 0.755 | | 0.755 | 4.25 | trace. | 16.616 | 0.106 |
| (Sweet) Martha..... | " " | | 1884 | 1.0332 | 11.15 | 13.81 | 0.708 | | 0.708 | 2.95 | 0.005 | 15.103 | 0.148 |
| (Sweet) Concord..... | " " | | 1884 | 1.0317 | 10.85 | 13.15 | 0.578 | | 0.578 | 3.00 | 0.010 | 15.448 | 0.204 |
| Thomasberger*..... | H. Mahler, Raleigh, N. C..... | | | 1.0365 | 11.51 | 14.27 | 0.554 | | 0.554 | 3.00 | 0.010 | 14.931 | 0.090 |
| Claret, Ives' Seedling..... | " " | | 1884 | 0.9952 | 10.46 | 12.96 | 0.963 | | 0.963 | 0.25 | 0.030 | 3.137 | 0.174 |
| Sweet Port, Clinton..... | " " | | 1885 | 1.0314 | 12.92 | 15.96 | 0.886 | | 0.886 | 2.00 | trace. | 10.952 | 0.202 |
| Dry Scuppernong..... | G. W. Lawrence, Fayetteville, N. C..... | | 1885 | 0.9931 | 13.80 | 17.02 | 0.655 | 0.014 | 0.669 | 0.50 | 0.005 | 3.698 | 0.116 |
| (Sweet) Scuppernong..... | " " | | 1881 | 1.0347 | 11.85 | 14.65 | 0.809 | | 0.809 | 3.00 | 0.005 | 14.300 | 0.140 |

*The Thomasberger was bought at a retail establishment, and its vintage is unknown.

No. XXXV.

ACTION OF CHLOROUS ACID UPON HEPTYLEN.

ROBERT G. GRISSOM.

The heptane from *Pinus Sabiniana* has been shown by Schorlemmer to be probably a normal heptane. The heptylen used in the following experiments was prepared from this heptane by first brominating it and then acting upon the secondary bromide formed with sodium ethylate. It was found that the best results were secured by allowing the sodium ethylate to act from twelve to twenty-four hours in the cold and then distilling off the heptylen and alcohol together. The end of the condenser tube may dip underneath water or, better end just above the surface of it, thus separating the alcohol from the heptylen. The latter does not seem to be soluble in water to any extent. This heptylen was dried, re-distilled and the portion boiling at 98—100° was used for the experiments.

The chlorous acid was formed by the action of sulphuric acid, diluted with two parts of water, on a mixture of potassium chlorate with half its weight of oxalic acid. The stream of chlorous acid gas mixed with carbon dioxide, thus produced, was then led into the tube containing the heptylen. To start the evolution of the gases the small flask containing the potassium chlorate and oxalic acid mixed with sulphuric acid was gently warmed by placing it in warm water. Application of cold water was used to moderate the action when necessary. Only ten or fifteen grammes of potassium chlorate were used at one time.

Following the directions of Domac (*Annalen d. Chemie* 213, p. 125), the heptylen (about 110 grammes) was placed in four tall test-tubes so that each was a little over half full. These were properly connected with the flask for generating the gases and were surrounded by ice-water. The gas delivery tube ended just above the surface of the heptylen, thus adopting Domac's pre-

caution, so as to avoid the troublesome explosions. To make the absorption as regular as possible the position of the tubes with reference to the generating flask was regularly changed. The absorption was rapid, the heptylen going through various changes of color from yellow to deep orange-brown. When the deeper color was reached, the tubes were disconnected from the generating flask and placed in direct sunlight until the orange-color was lost. If taken from the ice-water the heptylen became very warm and a rapid evolution of gas took place. It was much the best, and tended to prevent a complication of reactions, to keep the tubes all the time at a low temperature and to shade them well from sunlight during the passage of the gas. After some days the absorption took place more slowly and an exposure of many hours was needed for decolorization. Even with great care explosions would take place after the heptylen was largely saturated with the gas, and about half of the heptylen was thus lost. It was necessary then to stop before complete saturation or a permanent coloration was reached. The oily liquid was thoroughly washed with water until the washings no longer had an acid reaction. This wash-water acquired a pungent irritating odor. The remaining oil was dried over calcium chloride.

AQUEOUS SOLUTION.—On examining first the water used in washing, it was found strongly acid, still but little of the original liquid seemed to have gone into solution. A portion of the water was placed over sulphuric acid and on evaporation left a small residue, white, deliquescent and somewhat oily. The main part was apparently crystallized, contained chlorine and had the smell of acetic acid and its chlorine derivatives. The amount obtained was too small for purification or further attempts at identification. The remainder of the solution was neutralized with barium carbonate, changing from a clear liquid to a rosy flesh-color, with the same fruity, pungent, irritating odor. This was filtered and, after evaporating to a small bulk, the barium precipitated by sulphuric acid. After filtering again, it was distilled. Three fractions were taken. The first under 100° gave no test for chlorine. The second, $100\text{--}101^{\circ}$ contained chlorine. The

third, 101—110° contained both chlorine and sulphuric acid, the latter coming from the slight excess used in precipitating the barium. As the first only gave promise of interesting results, it was saturated with Ag_2O , filtered, evaporated over sulphuric acid and the thin crystalline film left was analyzed. As the amount of silver found was within two per cent. of that required for silver acetate it was concluded that the principal acid present in the aqueous solution was acetic acid. The presence of the chlorine, sulphuric acid and oily impurities prevented an examination of the other fractions for butyric or other acids and the amount was too small to attempt to purify them.

THE OIL INSOLUBLE IN WATER.—The oily portion after the washing and thorough drying over calcium chloride was subjected to fractional distillation under diminished pressure.* In this fractionation that part boiling below 120° was looked upon as mainly unchanged heptylen. The fraction from 120°—160° was set aside. It contained chlorine and in after attempts at reduction persistently retained it. The remaining portion was fractionated three times, yielding fractions as follows: A. 160°—173°; B. 173°—177°; C. 177°—185°; D. 185°—200°; and E. over 200°. This last fraction was quite small, the thermometer rising rapidly until only a few drops remained. None of these fractions were more than a few c. c. in amount. All were at first clear, colorless liquids, but the last two rapidly darkened even though in sealed tubes and carefully secluded from the light.

Fraction B was the largest in amount (6—7 c. c.), and as the thermometer rose slowly from 173°—177° this was supposed to be the purest substance or the nearest approach to a single chemical individual. As stated before, it was the result of three careful fractionations. It was subjected to the first and most com-

*It was found in this case and others where a not very stable product had to be distilled that a reduction of pressure by 100 mm. was sufficient to admit of the distillation going on without decomposition. Apparently all that was necessary was a rapid removal and condensation of the vapors formed so as not to subject them for any great length of time to the action of the heat or of products of decomposition already formed. The reduction of pressure reached could only lower the boiling point a few degrees.

plete examination. All of the temperatures by which these fractions are distinguished are subject to correction due to the pressure being reduced by 100 mm.

The following analyses were made of these respective fractions:

Fraction B, 173°—177°:

I. Amount taken = .3170 g; H₂O obtained = .2205; CO₂ obtained = .6300; H = .0245; C = .1718; p. e. H = 7.73; p. e. C = 54.19.

II. Amount taken = .3202; H₂O obtained = .2547; CO₂ obtained = .6336; H = .0283; C = .1728; p. e. H = 8.83; p. e. C = 53.94.

III. Amount taken = .4181; H₂O obtained = .3287; CO₂ obtained = .8268; H = .0365; C = .2255; p. e. H = 8.73; p. e. C = 53.93.

IV. Amount taken = .2785; silver chloride obtained = .3139; chlorine = .07758; p. e. Cl = 27.85.

V. Amount taken = .2750; silver chloride obtained = .3043; chlorine = .07513; p. e. Cl = 23.03.

Fraction C, 177°—185°:

VI. Amount taken = .3259; H₂O obtained = .2575; CO₂ obtained = .6544; H = .0286; C = .1785; p. e. H = 8.78; p. e. C = 54.77.

Fraction D, 185°—200°:

VII. Amount taken = .2642; H₂O obtained = .2087; CO₂ obtained = .5402; H = .0232; C = .1473; p. e. H = 8.78; p. e. C = 55.79.

Fraction E, over 200°:

VIII. Amount taken = .3165; H₂O obtained = .2513; CO₂ obtained = .6567; H = .0279; C = .1791; p. e. H = 8.81; p. e. C = 56.27.

IX. Amount taken = .2260; H₂O obtained = .1794; CO₂ obtained = .4672; H = .01993; C = .1274; p. e. H = 8.82; p. e. C = 56.38.

X. Amount taken = .2680; silver chloride obtained = .255; chlorine = .06295; p. e. Cl = 23.49.

The following table will show how these percentages compare with those calculated for the chlorine compounds which suggest themselves as possibly formed during the reaction:

| | B. | C. | D. | E. | C ₇ H ₁₃ Cl ₂ O. | C ₇ H ₁₄ Cl ₂ O. | C ₇ H ₁₄ Cl ₂ . |
|---------|-------|-------|-------|-------|---|---|--|
| H..... | 8.83 | 8.78 | 8.78 | 8.82 | 8.76 | 7.57 | 8.29 |
| C..... | 53.94 | 51.77 | 55.79 | 56.38 | 56.60 | 45.45 | 49.76 |
| Cl..... | 27.85 | | | 23.49 | 23.85 | 38.31 | 41.94 |

It will be observed that while the percentage of hydrogen is about the same throughout the percentage of carbon increases

up to the last fraction E. This one approaches in all of its percentages very nearly to $C_7H_{13}Cl_0$. That it is free from impurity is hardly possible because of inconstant boiling point. As to the nature of the more highly chlorinated body or bodies with which it is mixed, nothing can be determined by the analyses. From the great difficulty with which the chlorine was removed, it is most probable that simple chlorides were present. Nitric acid caused complete decomposition only in the neighborhood of 200° and nascent hydrogen failed to act.

As the nature of the reduction products would throw some light on the composition of these fractions, their reduction was attempted. First iron filings and acetic acid were used, then sodium amalgam, but the chlorine was not entirely removed even after days of action. The small amounts experimented with rendered vain any attempt at separation by distilling. To sum up the results of the action of hypochlorous acid upon heptylen from *Pinus Sabiniana*, we find acetic acid and some chlorinated solid acid formed by the oxidizing action, but the main portion changed into a chlorhydrin mixed probably with chlorides. The ease of decomposition of the hypochlorous acid renders it hardly possible to limit the nature of the reaction and prevent its becoming very complex.

No. XXXVI.

A NEW FORM OF BUNSEN BURNER.

[See figure at back of Journal.]

F. P. VENABLE.

In using gas prepared from gasoline for heating purposes in the laboratory, I have been much troubled by the smoky flame given by the ordinary burner when fresh gasoline is in the generator. This is due to the larger amount of light hydro-carbons present at that time and to the decreased pressure.

For the complete combustion of the gas, then, it is necessary to increase the proportion of oxygen admitted to secure a good flame, the pressure must be greater and a fine draught insured. Since devising this modification of the Bunsen burner, I have had no difficulty in the use of the carburetted air. The Springfield gas machine in use is a small one, holding about three barrels, and we pay careful attention to the specific gravity of the gasoline used and to the weight of the stone which runs the fan, thus securing the best results. The burner presents so many advantages in its use, however, that I have thought it advisable to draw attention to it as a good form also for laboratories where coal-gas is at command. The main feature is that the supply of gas is regulated at the base of the burner by a milled wheel and that this supply is diminished only at the issuing jet inside the chimney.

The advantages are: 1st. An easy and convenient mode of regulating the supply of gas, independent of the regulation of the air.

2d. The screw motion gives a means of securing a gradual and accurate decrease or increase of flame.

3d. As the gas is checked in its flow only at the issuing jet there is but little diminution of pressure, which for the use of gasoline gas is a very essential point. It enables one to secure a very small and still colorless flame.

4th. This burner is a very powerful one.

This burner has proved very satisfactory in the laboratory here, and very favorable reports of it have been received from laboratories using coal-gas where it has been tried. The burner is manufactured by Gilbert & Barker Manufacturing Company of New York.

No. XXXVII.

NOTE ON A NEW TEST FOR IRON.

F. P. VENABLE.

A solution of cobalt nitrate to which strong hydrochloric acid has been added, is blue. It was noticed that when some impure hydrochloric acid was used a green color was gotten instead of the blue. This change was traced to the iron in the acid, and as I have seen no mention of it elsewhere, I venture to give the present notice of this test. It is very simple, rapid and delicate for detecting traces of iron and is especially useful in testing strong acids. The delicacy of the test is such that when even $\frac{3}{100000}$ of a gramme of a ferric salt are added to the blue strongly acid solution mentioned above, the green is clearly given. With a somewhat larger amount this green is quite vivid. If too much of the ferric solution is used the cobalt solution becomes pink from the addition of water. The test is not given by ferrous salts, nor does the presence of ferrous salts interfere with it. I have thought that the green was due to the addition of yellow ferric chloride to blue cobalt solution. Other yellow solutions which I have tested failed, however, to give the green.

ELECTROLYSIS OF WATER.

[See figure at back of Journal.]

F. P. VENABLE.

A short note recently appeared in the Journal of Analytical Chemistry (No. 3, 1887, p. 287), describing a simplification of the ordinary condenser. Adopting, in part, the same idea, I have devised the following simplification of Hofmann's apparatus for the electrolysis of water. This will prove useful where the high

price of the ordinary apparatus is a serious objection to its use, or where one is at a distance from the supply stores and hence forced to make use of some substitute for the store-bought article.

The figure at the end of this Journal will show the form of the apparatus. B B are two tubes (about 8 x $\frac{1}{2}$ inch) which can easily be gotten in the form in the diagram by taking a single tube of double the length mentioned, giving it the desired bend and then scratching and breaking in the middle. A stout piece of rubber tubing unites these at A. This tubing is by means of a cork-borer perforated in the centre between the tubes B. Into this opening a tube C is inserted, bent at right-angles at P and with its end enlarged to prevent leaking. It is not necessary to bend at right-angles for some kinds of supports, but the opening in the rubber A may be directly on top and the tube C let right into it. D is a funnel with stop-cock fastened to C by the rubber connection A. Into the tubes B wires F F (best of platinum, with flattened ends, though copper will answer) are placed, reaching nearly to the bend and coming out under the rubber connections O O, passing a short way down the outside, wound round the tube two or three times and ending in loops to which the battery wires may be attached. The tubes B B are connected with jet pieces by means of rubber tubing, and can be tightly closed by pinch-cocks. All rubber connections must be tightly wound with wire to prevent leakage. The gases produced can be examined at the jets, or a delivery tube attached, running under a test-tube which is placed in a pneumatic trough. As a support the ordinary iron retort-stand may be used, fastening the tubes with wires. It is better, however, to have a board, blackened or covered with black paper, and nailed to a block so as to stand upright. The tubes B B can be fastened to this by wires going through gimlet-holes. The funnel D can rest in a hole or slit cut in a thin strip tacked across the top of the board.

LIST OF PAPERS

READ AT THE

REGULAR MEETINGS, FALL TERM, 1887.

XXIX REGULAR MEETING.

September 12, 1887.

1. Garnierite from Jackson County, N. C. *W. B. Phillips.*
2. Phosphorescence in an Earth-worm *G. F. Atkinson.*
3. A Peculiar Ant's Nest *G. F. Atkinson.*
4. Additional Notes on the Glow-worm..... *G. F. Atkinson.*
5. The Mastodon in North Carolina *J. A. Holmes.*
6. Triassic Traps *J. A. Holmes.*
7. Geological Maps of the Counties of South Carolina, *J. A. Holmes.*
8. Formations at the Head of Chesapeake Bay *J. A. Holmes.*
9. A Profile Map from Morrisville to Newbern..... *J. A. Holmes.*
10. Report on the Meeting of the American Association
for the Advancement of Science.... *J. A. Holmes.*
11. Analyses of North Carolina Wines.. $\left\{ \begin{array}{l} \textit{F. P. Venable.} \\ \textit{W. B. Phillips.} \end{array} \right.$

XXX REGULAR MEETING.

October 11, 1887.

12. Limits of the Senses *F. P. Venable.*
13. Apparatus for the Electrolysis of Water *F. P. Venable.*
14. A Cotton Plant Having Seeds and no Lint..... *J. A. Holmes.*
15. Report on Progress in Physics *J. W. Gore.*
16. Report on Progress in Geology..... *J. A. Holmes.*
17. Report on Progress in Mineralogy and Metallurgy... *W. B. Phillips.*

XXXI REGULAR MEETING.

November 8, 1887.

18. Historical View of the Elements *F. P. Venable.*
19. The Origin of the Hudson River Palisades..... *J. A. Holmes.*
20. A New Food-plant for *Blissus Cncopterns* *G. F. Atkinson.*
21. The Rust Mite on Cotton *G. F. Atkinson.*
22. A List of Birds Collected by Students at Chapel
Hill, Spring of 1877 *G. F. Atkinson.*
23. Report on Progress in Chemistry... *F. P. Venable.*
24. Report on Progress in Metallurgy and Mining..... *W. B. Phillips.*

PUBLIC LECTURES.

VIII PUBLIC LECTURE.

September 26, 1887.

Bread and Brains.....*Dr. W. B. Phillips, Chapel Hill.*

IX PUBLIC LECTURE.

December 6, 1887.

Ditch Water.....*Prof. W. L. Poteat, Wake Forest.*

USE OF THE LIBRARY.

The following abstract from the Minutes is printed for the information of members:

Council Meeting, December 10, 1887. The following resolutions were passed:

1st. That a list of all publications received be published in each issue of the Journal.

2d. That by payment of postage any member can have a book or pamphlet in the library mailed to his address. Postage must be prepaid.

3d. The book or pamphlet must be returned at the close of two weeks, the member borrowing it paying for the return.

Information as to articles on special subjects appearing in Journals can generally be gotten by applying to the Secretary, enclosing a stamp for reply.

Where abstracts of articles are desired, the services of an associate member can probably be secured.

PUBLICATIONS

RECEIVED SINCE JULY, 1887.

AUGSBURG—Naturwissenschaftlicher Verein für Schwaben and Neuburg. 1877, 1879, 1881, 1883, 1885.

BELFAST—Naturalists' Field Club. Series II, Vol. II, Pt. VI.

BERLIN—Entomologischer Verein, Zeitschrift. 1887.

BONN—Naturhistorischer Verein, Verhandlungen. 1887.

BREMEN—Naturwissenschaftlicher Verein, Abhandlungen. Band IX, 3 and 4.

BOSTON—American Academy of Arts and Sciences, Vol. XXII Popular Science News. July–December, 1887.

BALTIMORE—Johns Hopkins University Circulars, Nos. 59, 60, 61; Modern Language Notes. December, 1887.

CHAMPAIGN—Illinois State Laboratory of Natural History, Vol. II.

CINCINNATI—Society of Natural History, Vol. X, 2 and 3.

DANZIG—Naturforschende Gesellschaft, Schriften Neue Folge. Band VI, 4.

DUMFRIES—Natural History and Antiquarian Society, Transactions. 1883, 1884, 1884-'85, 1885-'86; List of Flowering Plants of Dumfrieshire and Kirkcudbrightshire.

FRIBOURG—Société des Sciences Naturelles, Bulletin. 1879-'80, 1880-'81, 1881-'82.

FRANKFORT—Senckenbergische Naturforschende Gesellschaft, Bericht. 1887.

MADISON—Wisconsin Academy of Sciences, Arts and Letters. Vols. III, IV, V, VI.

MAGDEBURG—Naturwissenschaftlicher Verein, Jahresbericht und Abhandlungen. 1886.

MONTREAL—Natural History Society, Canadian Record of Science, Vol. II, 5 and 6.

MICHIGAN—Horticultural Society, Grand Rapids, Reports 1874, '75, '76 '79, '80, '81, '82, '83, '84, '85, '86.

MOSCOW—Société Imperiale des Naturalistes, Bulletin. 1886, 4; 1887, 1. Meteorologische Beobachtungen. 1886, 2.

NEW HAVEN—Connecticut Academy of Arts and Sciences, Vol. VII, Pt. I.

NEW YORK—Academy of Sciences, Transactions, Vol. I, 7, 8; Vol. II, Vol. V; Annals, Vol. III; Linnean Society, Vols. I and II.

ODESSA—Société des Naturalistes de la Nouvelle—Russie, Journal, Vols. X and XI; Flora Chersonsis, Vols. I and II; Die Fossilien Vogel Knochen der Odessaer—Steppen.

OTTAWA—Royal Society of Canada, Vols. I, II, III, IV; Field Naturalists' Club; Ottawa Naturalist, Vol. I, 4-9.

PHILADELPHIA—Academy of Natural Sciences, 1887, Pts. I and II; Wagner Free Institute of Science. Vol. I.

PISA—Società Toscana di Scienze Naturali, Atti, Vol. V.

MEXICO—Sociedad Mexicana de Historia Naturel, La Naturaleza, Tomo I, 4.

RALEIGH—North Carolina Horticultural Society Report, 1886; Department of Agriculture Bulletins, 1887.

REGENSBURG—Naturwissenschaftlicher Verein, Correspondenz Blatt, Jahrgänge, 39 and 40.

PORT HOPE—Canadian Entomologist, Vol. XIX.

LEIPZIG—Insekten—Börse, Nos. 21, 22 and 23.

ROTHAMSTED—Memoranda of Experiments, June, 1887.

TORONTO—Canadian Institute Journal, 3d Series, Vol. V, Fascie 1.

STATEN ISLAND—Natural Science Association, Proceedings 1887.

WASHINGTON—National Academy, Smithsonian Institution, National Museum Reports, 2-9; Department of Agriculture—Report of Commissioner for 1887.

WILMINGTON—North Carolina Board of Health Bulletins, July-December, 1887; North Carolina Medical Journal, July-December, 1887.

WASHINGTON—U. S. Signal Service, Weather Review, 1887; List of Entomological Writings of Dr. A. S. Packard.

SAN DIEGO—West American Scientist, Nos. 26-31.

SAN FRANCISCO—California Academy of Sciences, Vol. II, No. 7.

ZURICH—Der Naturforschende Gesellschaft Vierteljahrschrift, 1883-'86.

AN INDEX

TO THE FIRST FOUR VOLUMES, 1883—1887.

- Abies Canadensis* and *Pinus Strobus* in Central North Carolina. I, 86.
Alumina, solubility of in sulphuric acid. IV, 1st 56.
Ammonia in Saliva. II, 85.
Ammonium Citrate, neutrality of in determining Phosphoric Acid. III, 58.
Ant, singular adaptation of nest-making by an. IV, 2d 88.
Artesian Well at Durham, N. C., analysis of water from. IV, 1st 57.
Atkinson, G. F. III, 68, 74. IV, 1st, 13, 16, 26, 33. IV, 2d 44, 88, 89, 92.
Barium Chromate, solubility of. II, 90.
Battle, H. B. III, 27, 30, 32, 48, 51, 53, 54, 58.
Battle, K. P. I, 45.
Battle, R. H. I, 45.
Birds of North Carolina, preliminary catalogue of the. IV, 2d 44.
Blephilia Ciliata, sport in leaf of. II, 94.
Borden, J. L. I, 43, 53, 87.
Burner, new form of. IV, 2d 103.
Butter from weighed amounts of milk. I, 68.
Caffein in Yeopon leaves. I, 85.
Camphoric Acid, new salts of. IV, 1st 52.
Carbon Bisulphide, hydrated. I, 69.
Cassiterite from King's Mountain, N. C. I, 79.
Chapel Hill, elevation of. I, 82.
Chapel Hill, latitude of. II, 32.
Chapel Hill, analysis of well-waters in. I, 23.
Chapel Hill, temperature of the well-waters in. I, 82.
Cigarette Beetle. III, 68.
Coal, analyses of bituminous North Carolina and Tennessee. III, 51.
Constitution. I, 90.
Copper and Barium Acetate, attempt at forming. I, 50.
Cotton-seed Analyses. I, 54.
Curtis, Rev. M. A., sketch of botanical work of. II, 9.
Cyclones. III, 145.
Dabney, C. W. Jr. I, 64, 79.
Dancy, F. B. II, 41, 66; III, 37, 43; IV, 2d 41.
Dog Tooth Spar, analysis of. II, 62.
Earth-worm, remarkable case of phosphorescence in. IV, 2d 89.
Electrolysis of water. IV, 2d 105.
Elements historically considered. IV, 2d 36.

- Eocene deposits in Eastern North Carolina. II, 79.
 Exchanges, list of. IV, 1st 66.
 Fall of blood in Chatham county, N. C. I, 38.
 Fertilizer trade in North Carolina in 1886. IV, 1st 58.
 Filters washed with hydrofluoric acid. I, 86.
 Flora, Wilmington. III, 77.
 Floras, study of local. IV, 2d 25.
 Flowering and foliation of plants. I, 45.
 Freezing of standard solutions. III, 43.
 Gasoline on Copper, action of. I, 88.
 Gore, J. W. I, 5, 8, 51, 82; II, 3, 32; III, 3.
 Grady, B. F. III, 145.
 Grissom, R. G. IV, 1st 55, 56. IV, 2d 99.
 Harris, T. W. II, 59.
 Hematite from Forsyth county, N. C. II, 95.
 Hentz, N. M., sketch of. IV, 1st 13.
 Heptylen, action of chlorous acid upon. IV, 2d 99.
 Heptyl-Benzol, attempts at forming. II, 77.
 Holmes, J. A. I, 28, 73, 86; II, 59, 92, 94; IV, 1st 5; IV, 2d 1.
 Howe, J. L. II, 69; III, 143, 144.
 Hyams, M. E. II, 72, 94.
 Ilex Cassine, analysis of leaves of. II, 39.
 Indian antiquities of Caldwell county, N. C. III, 45.
 Indian burial mounds in Eastern North Carolina. I, 73.
 Iron, a new test for. IV, 2d 105.
 Iron ores from Chapel Hill mine, analyses of. I, 26.
 Jackson, Max. II, 46, 85.
 Kaolin from Jackson county, N. C. II, 93.
 Kerr, J. P. I, 68.
 Kerr, W. C. II, 79, 86.
 Kerr, W. C., obituary notice. II, 8.
 Kerr, W. C., biography of. IV, 2d 1.
 Lead chloride, action of ammonium hydrate on. I, 24.
 Lead, chlor-sulpho-cyanide. IV, 1st 55.
 Lead iodide, action of ammonium hydrate on. I, 43.
 Lithographic stone from Tennessee. III, 144.
 Library, gifts to. II, 96.
 Library, use of. IV, 2d 108.
 Magnetite from Orange county, N. C. I, 87.
 Manning, I. H. II, 93, 95; IV, 1st 52, 54.
 Members, list of. I, 93; II, 97.
 McCarthy, Gerald. III, 77; IV, 2d 25.
 Mercurous hypophosphite, attempts to form. II, 78.
 Meteorological record at Chapel Hill. I, 35; II, 48; III, 34.
 Mitchell, Elisha, sketch of. I, 9.

- Moisture in commercial fertilizers. III, 54.
Moisture, loss of in bottled samples. III, 30.
Octyl Benzol. III, 60.
Orchard Scolytus. III, 74.
Peanuts, occurrence of citric and malic acids in. II, 47.
Petrified human body. II, 59.
Phengodes Laticollis, female form of. IV, 2d 92.
Phillips, C. I, 9.
Phillips, Jas. I, 35, 45.
Phillips, W. B. I, 21, 56, 60; II, 33, 60, 62; IV, 1st 58. IV, 2d 96.
Phosphate, manufacture of acid. II, 33.
Phosphates in North Carolina. I, 60, 64.
Phosphate rock from North Carolina, solubility of. I, 53.
Phosphoric acid, insoluble, effect of organic matter on. IV, 2d 41.
Phosphoric acid, reverted, comparison of methods for determining. III, 48.
Phosphoric acid, soluble, use of different amounts in determining. III, 53.
Phosphoric acid, total, determination of. II, 41.
Phosphoric acid, reversion by heat. I, 21.
Phosphorus, amorphous, alterability of. I, 37.
Phosphorus, reactions of. II, 57.
Pickel, J. M. III, 40.
Plants of North Carolina, additions to catalogue of. II, 72.
Plants around Wilmington, catalogue of. III, 77.
Plant transpiration. II, 63.
Potash, determination of. III, 37.
Potassium Cyanide, decomposition of. I, 18; IV, 1st 54.
Propenyl-iso-toluylen-amidine. III, 40.
Pulverization, effect on fertilizer samples. III, 27.
Radcliffe, Thos. I, 83, 84.
Report of President. I, 3.
Report of Secretary. I, 5; II, 5; III, 5; IV, 1st 8.
Report of Treasurer. I, 8; II, 7; III, 8; IV, 1st 12.
Report of Vice-President. II, 3; III, 3; IV, 1st 5.
Roberts, J. C. I, 26, 37, 50.
Salt-making, analysis of a deposit from. II, 60.
Salt from Saltville, Va., analysis of. I, 83.
v. Schweinitz, E. A. I, 23, 54; II, 47, 78; III, 60, 63.
v. Schweinitz, L. D., sketch of life and scientific works of. III, 9.
Senses, limits of. IV, 2d 31.
Sodium Chloride as a wash. II, 66.
Spainhour, J. M. III, 45.
Specular iron ore from Forsyth county, N. C. II, 95.
Spider, new Trap-Door. IV, 1st 16.
Spiders, nests, &c., and food habits of some Trap-Door. IV, 1st 33.
Spiders, a family of young. IV, 1st 26.

- Spiegel-iron from North Carolina, analysis of. II, 46.
 Stephenson, J. A. D. I, 40.
 Storm of April 22d, 1883. I, 83.
 Sugar beets from Kentucky. III, 143.
 Sugar in urine, quantitative determination of. II, 69.
 Superphosphates from Red Navassa Rock, reversion in. I, 56.
 Tampa, Fla., geology of the region about. II, 86.
 Taxodium in North Carolina quaternary. II, 92.
 Thermometer for class illustration. III, 142.
 Thiophen octyl derivatives. III, 63.
 Tornado in Catawba and Iredell counties, March 25, 1884. I, 40.
 Tornado in Richmond county, February 19, 1884. I, 28.
 Tornadoes, theory of. I, 51.
 Twisting of trees. II, 94.
 Venable, F. P. I, 3, 38, 47, 69, 82, 83, 85, 86, 88; II, 5, 7, 39, 48, 57, 63, 77;
 III, 5, 8, 34, 142; IV, 1st 8, 12, 57; IV, 2d 31, 36, 96, 103, 105.
 Wash-bottle for chemical laboratories. III, 32.
 Wilkes, J. F. I, 18; II, 90.
 Wilson, A. E. II, 95.
 Wines from North Carolina, analyses of. IV, 2d.
 Wood, Julian. I, 24.
 Wood, Thos. F. II, 9; III, 77.
 Yeopon, analysis of leaves. II, 39.
 Zinc in drinking water. I, 47.
 Zinc, oxide deposit of. I, 84.

PLATES AND ILLUSTRATIONS.

- Portrait of Elisha Mitchell, D. D. Vol. I.
 Portrait of M. A. Curtis, D. D. Vol. II.
 Portrait of L. D. v. Schweinitz, D. D. Ph. D. Vol. III.
 Map of New Hanover county, N. C. Vol. III.
 A new Trap-Door Spider, Pl. I, Pl. II. Vol. IV, 1st.
 Family of T. D. Spiders, Pl. I, Pl. II. Vol. IV, 1st.
 Portrait of W. C. Kerr, Ph. D. Vol. IV, 2d.
 Ants' Nest. Vol. IV, 2d.
 Earth-worm. Vol. IV, 2d.
 A new Bunsen Burner. Vol. IV, 2d.
 Electrolysis of water. Vol. IV, 2d.
 Figures in the text. Vol. I, 52; Vol. III, 32; Vol. III, 142.

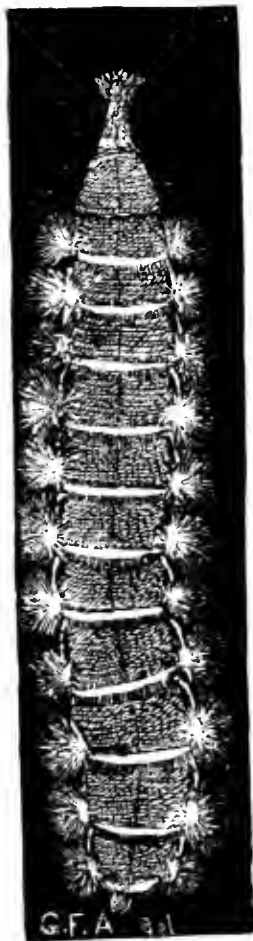

Phengodes latifollis, showing
luminosity.

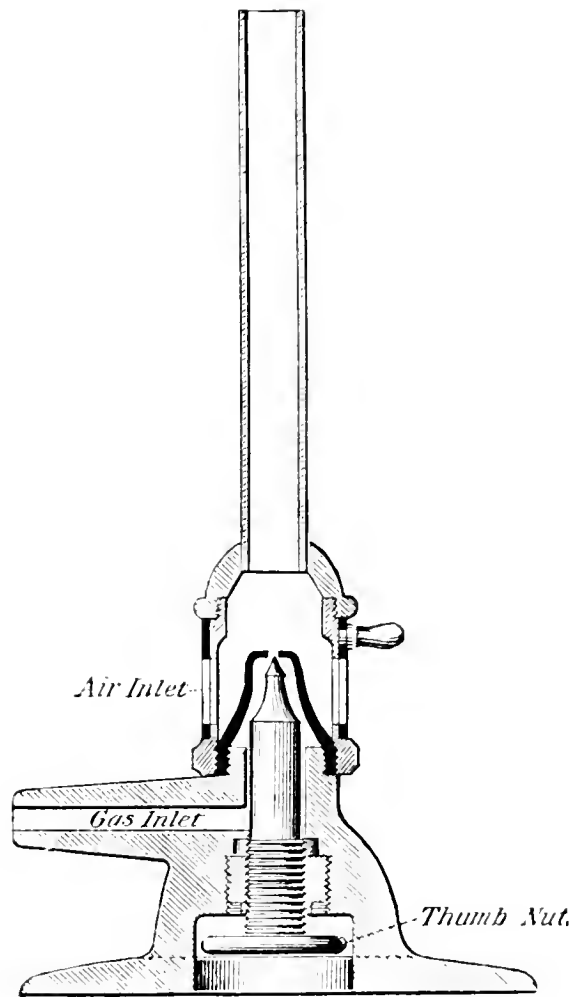

A NEW FORM OF "BUNSEN" BURNER.

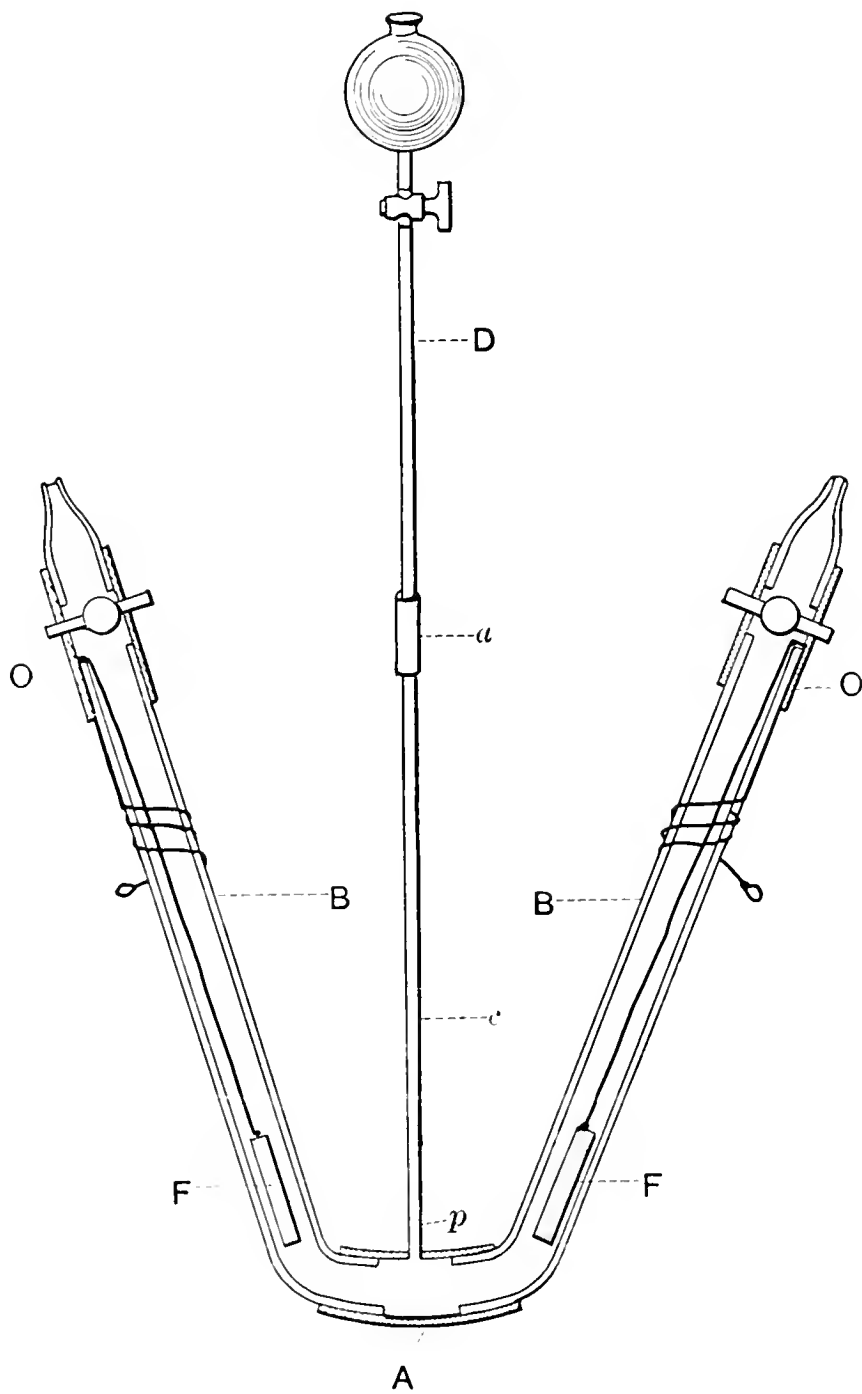

Apparatus for Electrolysis of Water.

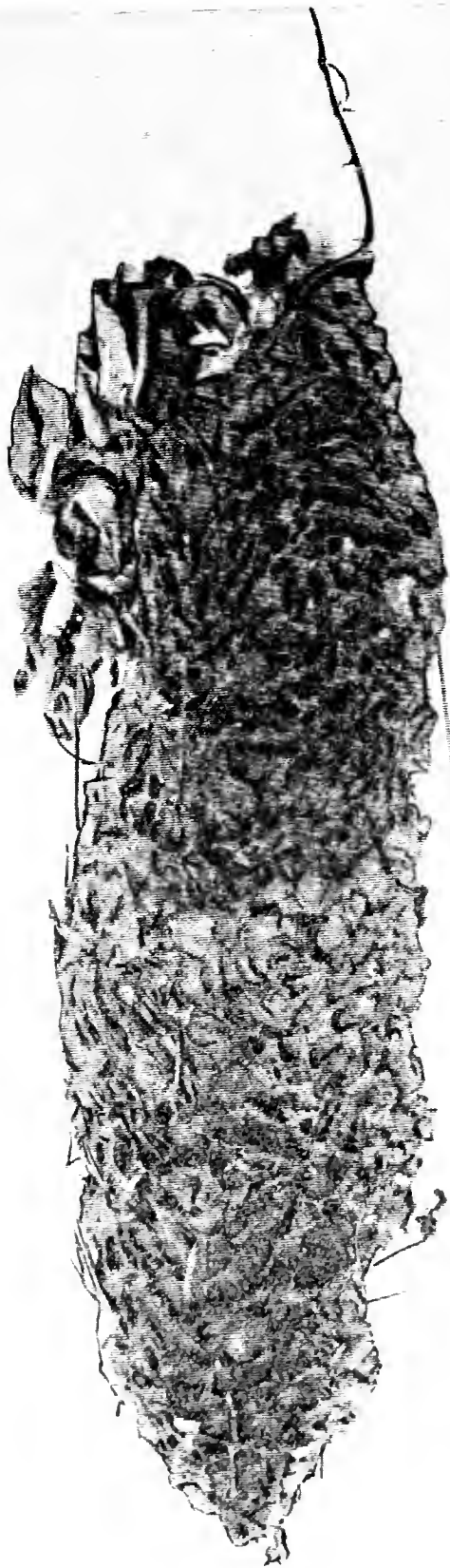







3 2044 106 256 076

