

B. E. STECHBART

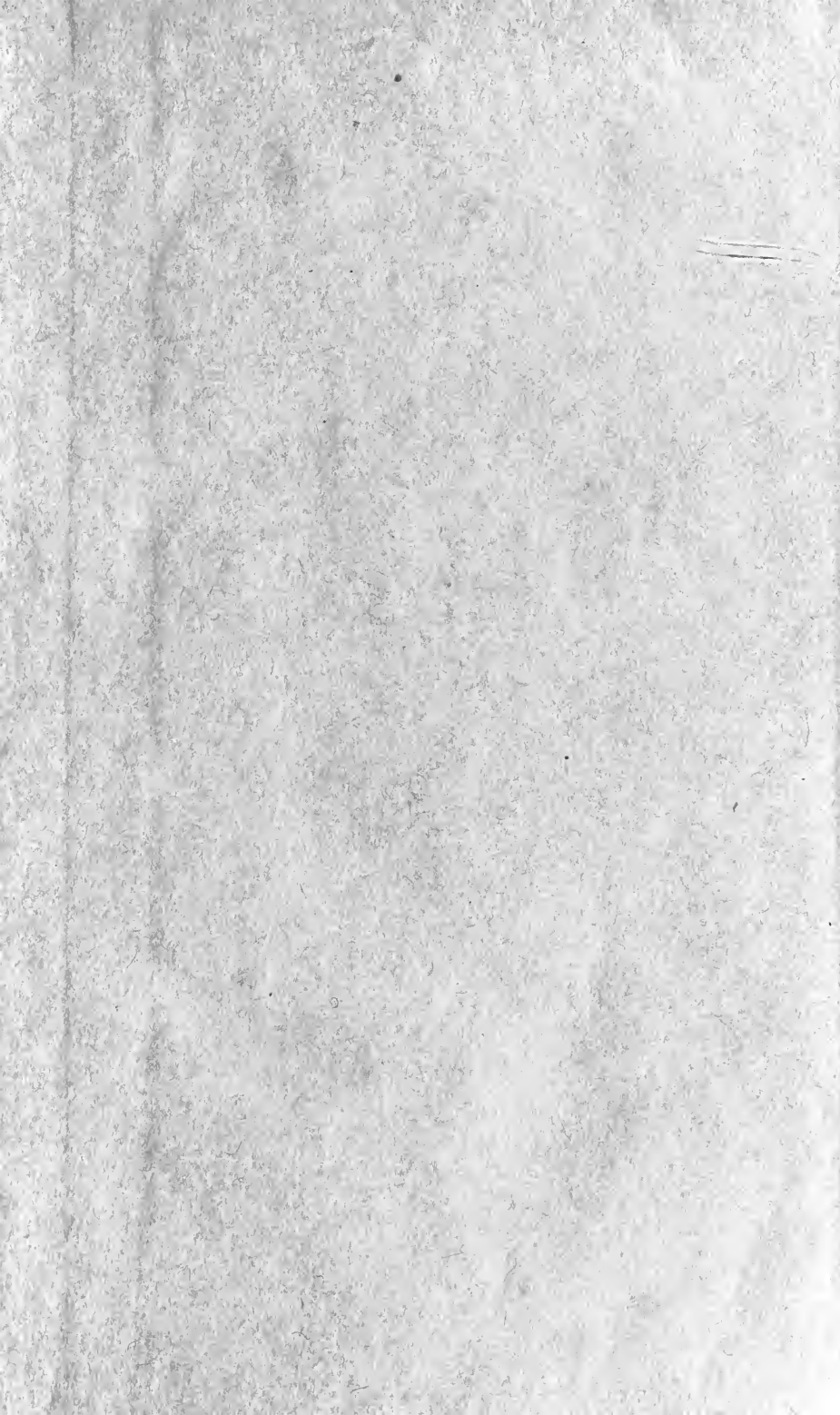

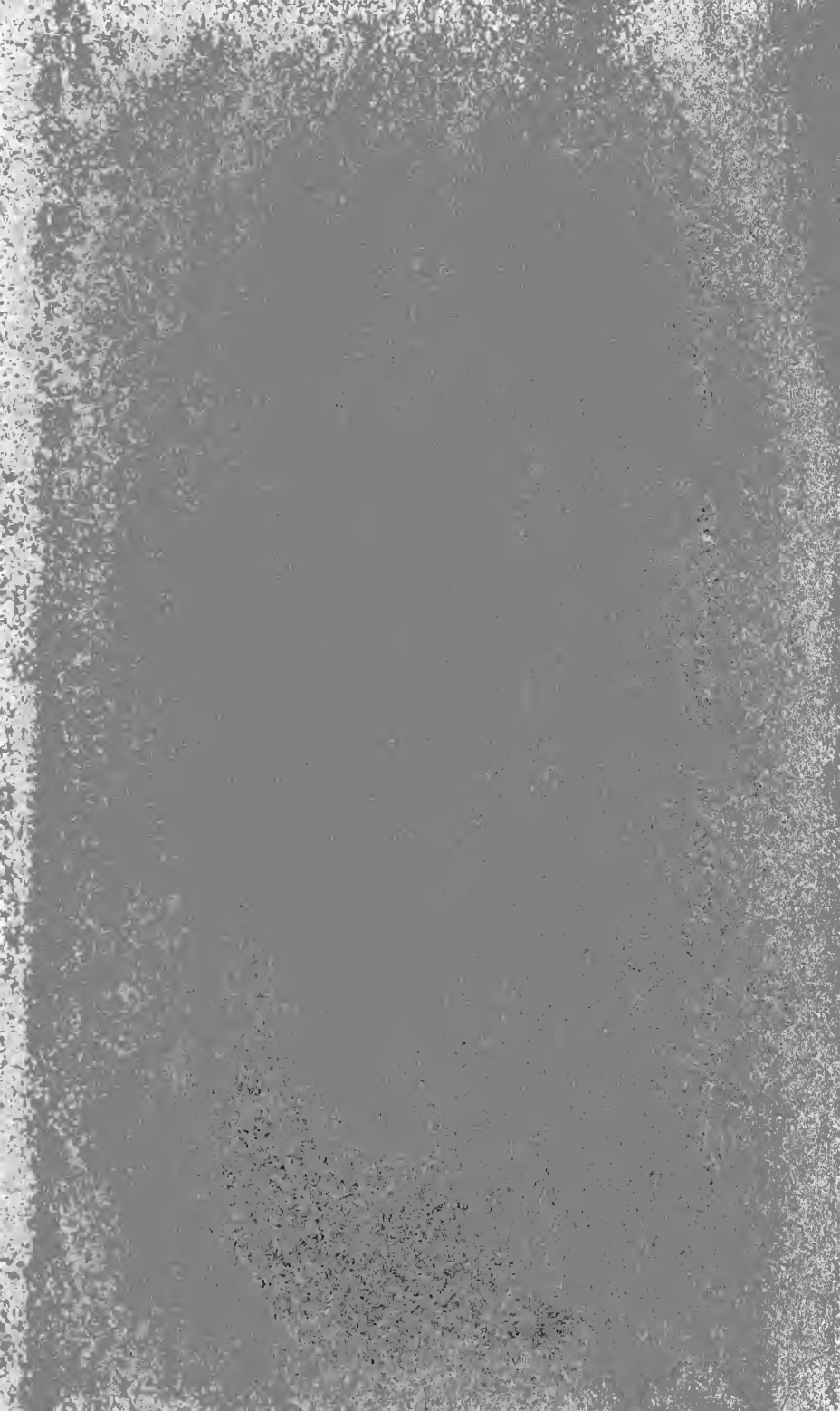

Digitized by the Internet Archive
in 2007 with funding from
Microsoft Corporation

JOURNAL OF THE SOCIETY OF MOTION PICTURE ENGINEERS

Vol 42

JANUARY, 1944

No. 1

CONTENTS

	PAGE
Report on Engineering of the Society of Motion Picture Engineers D. E. HYNDMAN	1
Motor Systems for Motion Picture Production A. L. HOLCOMB	9
A Review of Hypo Testing Methods J. I. CRABTREE, G. T. EATON, AND L. E. MUEHLER	34
Character of Waves Produced by Explosions E. W. KELLOGG	58
Fifty-Fifth Semi-Annual Technical Conference of the Society	68

(The Society is not responsible for statements of authors.)

JOURNAL OF THE SOCIETY OF MOTION PICTURE ENGINEERS

HARRY SMITH, JR., EDITOR
ARTHUR C. DOWNES, *Chairman*

Board of Editors

JOHN I. CRABTREE ALFRED N. GOLDSMITH EDWARD W. KELLOGG
CLYDE R. KEITH ALAN M. GUNDELFINGER CHARLES W. HANDLEY
ARTHUR C. HARDY

Officers of the Society

- **President:* HERBERT GRIFFIN,
133 E. Santa Anita Ave., Burbank, Calif.
- **Past-President:* EMERY HUSE,
6706 Santa Monica Blvd., Hollywood, Calif.
- **Executive Vice-President:* LOREN L. RYDER,
5451 Marathon St., Hollywood, Calif.
- ***Engineering Vice-President:* DONALD E. HYNDMAN,
350 Madison Ave., New York, N. Y.
- **Editorial Vice-President:* ARTHUR C. DOWNES,
Box 6087, Cleveland, Ohio.
- ***Financial Vice-President:* ARTHUR S. DICKINSON,
28 W. 44th St., New York, N. Y.
- **Convention Vice-President:* WILLIAM C. KUNZMANN,
Box 6087, Cleveland, Ohio.
- **Secretary:* E. ALLAN WILLIFORD,
30 E. 42d St., New York, N. Y.
- **Treasurer:* M. R. BOYER
350 Fifth Ave., New York, N. Y.

Governors

- **FRANK E. CARLSON, Nela Park, Cleveland, Ohio.
- *CHARLES W. HANDLEY, 1960 W. 84th St., Los Angeles, Calif.
- **EDWARD M. HONAN, 6601 Romaine St., Hollywood, Calif.
- *CLYDE R. KEITH, 195 Broadway, New York, N. Y.
- **JOHN A. MAURER, 117 E. 24th St., New York, N. Y.
- *HOLLIS W. MOYSE, 6656 Santa Monica Blvd., Hollywood, Calif.
- *WILLIAM A. MUELLER, 4000 W. Olive Ave., Burbank, Calif.
- *H. W. REMERSHIED, 716 N. La Brea St., Hollywood, Calif.
- **EARL I. SPONABLE, 360 W. 54th St., New York, N. Y.
- *JOSEPH H. SPRAY, 1277 E. 14th St., Brooklyn, N. Y.
- *REEVE O. STROCK, 195 Broadway, New York, N. Y.
- **WALLACE V. WOLFE, 1016 N. Sycamore St., Hollywood, Calif.

*Term expires December 31, 1944.

**Term expires December 31, 1945.

Subscription to non-members, \$8.00 per annum; to members, \$5.00 per annum, included in their annual membership dues; single copies, \$1.00. A discount on subscription or single copies of 15 per cent is allowed to accredited agencies. Order from the Society of Motion Picture Engineers, Inc., Hotel Pennsylvania, New York 1, N. Y.

Published monthly at Easton, Pa., by the Society of Motion Picture Engineers, Inc.

Publication Office, 20th & Northampton Sts., Easton, Pa.

General and Editorial Office, Hotel Pennsylvania, New York 1, N. Y.

Entered as second-class matter January 15, 1930, at the Post Office at Easton, Pa., under the Act of March 3, 1879. Copyrighted, 1944, by the Society of Motion Picture Engineers, Inc.

JOURNAL OF THE SOCIETY OF MOTION PICTURE ENGINEERS

VOL 42

JANUARY, 1944

NO. 1

REPORT ON ENGINEERING OF THE SOCIETY OF MOTION PICTURE ENGINEERS*

D. E. HYNDMAN**

INTRODUCTION

One of the major inherent characteristics of scientists, engineers, and technically trained personnel, either as individuals or as groups of individuals, is a general tendency to be overmodest about their accomplishments. The membership comprising the Society of Motion Picture Engineers is no exception to this characteristic, but it does seem justifiable to review the technical accomplishments of our Society on the basis of the record.

From the initial organization of the Society of Motion Picture Engineers in the year of 1916, it has led the motion picture industry to accept technical improvements that have been major contributions for continually increasing the efficiency of operation in production, distribution, and exhibition, and patronage at the box office. As would be expected, this is attained through the close coöperation and understanding of various technically trained individuals who are employed either directly or indirectly within the motion picture industry. Because of the mutual understanding and appreciation of the problems in the related fields of production, distribution, and exhibition, it has been possible to bring about engineering advances that might otherwise have remained dormant for many years.

All services that the Society has rendered to the industry have been gratis for all practical purposes. This is due to the fact that the Society has been financed principally by its individual members, with limited sustaining contributions from only the manufacturers of various types of motion picture equipment until the last 2 or 3 years. The Society is still mainly financed by contributions of its

* Presented Oct. 18, 1943, at the Fall Technical Conference in Hollywood.

** Engineering Vice-President of the Society.

individual members and these limited contributions. The technical or engineering services and development that have been completed by or through the Society and its members individually have occurred without fanfare or general publicity.

Since the work, aims, and accomplishments of the Society are not generally publicized or even too well known by many of its members, it does seem that a brief résumé of the past, present, and future technical work and plans will reveal the importance of the engineering the Society does for the motion picture industry.

ENGINEERING CONTRIBUTIONS

To appreciate the full extent and coverage by the Society of Motion Picture Engineers in the engineering field of the motion picture industry, it should be emphasized that there are 16 major engineering or technical committees of the Society: Cinematography, Color, Exchange Practice, Laboratory Practice, Non-Theatrical Equipment, Preservation of Film, Process Photography, Sound, Standards, Studio Lighting, Television, Theater Engineering, Projection Practice, Theater Design, Screen Brightness, and Theater Protection. Many sub-committees of the major committees continually study various specific procedures in their respective fields in order to always be familiar with current practice and to be prepared to recommend improvements.

Each of the committees is comprised of a membership representative of the technical and engineering authorities from each specific field of endeavor. All of the membership is appointed from the personnel of the producers, distributors, and exhibitors of the motion picture industry and also from manufacturers of equipment, accessories, and film. Often the Society feels it is necessary to have non-members of the SMPE serve on these committees. If this is necessary, then non-member engineering authorities are requested to serve on a committee for the sole purpose of broadening the scope of the work of the committee.

Reports, data, specifications, or recommendations of procedure or tests are never published until each and every committee concerned with the material, the Board of Governors, and the Board of Editors have approved. This method of handling such important problems encourages a profound faith in the practical application of the recommendations as well as minimizing possible errors in preparation of the recommendations or specifications.

(1) *Standardization.*—The Committee on Standards of the Society is the parent of all technical committees and is the committee to which all matters to be considered for any type of standardization must be referred for approval before the material can be referred to the Board of Governors for final approval as far as the Society is concerned. The Committee on Standards is comprised of the most able and well-known technical and engineering authorities in all of the respective fields of the motion picture industry so that it is only natural that each and every other technical committee has representation. In addition, there are also members of the Committee on Standards who may not necessarily be serving on any other technical committee.

Either through, or by the Society practically all standardizations, methods, procedure, design, construction, operation, safety codes, definitions, abbreviations, *etc.*, have been accomplished. This standardization in recent years has been done in conjunction with the Research Council of the Academy of Motion Picture Arts and Sciences. Standardization has improved equipment, methods, and procedure which has resulted in increasing production output at a lower cost. Specific details of recommendations will be given later which will show that these recommended improvements have increased efficiency in the 3 major phases of the motion picture industry—production, distribution, and exhibition.

The fact that the Society sponsors the Sectional Committee on Motion Pictures (Z-22) of the American Standards Association offers to the industry a direct and efficient means of presenting all technical matters to be considered for standardization. Both the Committee on Standards of the Society and the Sectional Committee are composed of representatives, technical and engineering authorities, from the motion picture industry, representing producers, distributors, exhibitors, and manufacturers of all types of motion picture equipment and accessory material. This very representation insures a most democratic procedure and minimizes any tendency to promote a singleness of thought for self-advancement.

(2) *Engineering or Technical Publications and Work in Progress.*—A brief review of the engineering and technical publications and the work in progress by the Society will reveal the magnitude of the problems which have been ably handled, and on which additional studies are still continuing in the interests of further improvement in the presentation of motion pictures to the public.

The Committees on Cinematography, Color, Laboratory Practice, Preservation of Film, Process Photography, Sound, Standards, Theater Engineering, Projection Practice, and Screen Brightness have published numerous reports dealing with the various specific and general phases of their particular fields which have become technical and practical reference sources for information about procedures, methods of test, specifications, design, construction, operation of equipment, and the like, for the production of motion pictures.

The Committees on Exchange Practice, Laboratory Practice, Preservation of Film, Standards, and Screen Brightness have published reports that have accomplished a result for the handling of film during distribution similar to that done by these and other committees for the production of motion pictures.

The Committees on Exchange Practice, Sound, Standards, Theater Engineering, Projection Practice, Theater Design, and Screen Brightness have provided very specific recommendations and specifications which have become reference sources for exhibition practice.

The magnitude, scope, and value of these technical or engineering contributions become immediately apparent by reference to the index of the JOURNAL of the Society of Motion Picture Engineers from the date of initial publication of the first issue in the year of 1916 up to and including the current issue. To realize the extent of these contributions it does seem worth while to mention a few of the committee reports that have become an integral part of the motion picture industry:

Committee on Color

- (1) Commercial Color Systems (1930).
- (2) Commercial Color Systems (1931).
- (3) Commercial Color Systems, Classification of Color Patents (1931).
- (4) Present Status of Color (1932).
- (5) Nomenclature and Standardization of Color (1935).
- (6) Glossary of Color Photography (1935).

Committee on Exchange Practice

- (1) Current Practice in Handling Release Prints (1933).
- (2) Release Print Length (1934).
- (3) 2000-Ft Reel (1935).

Committee on Laboratory Practice

- (1) Current Laboratory Practice (1936).

Committee on Non-Theatrical Equipment

- (1) German Specifications for 16-Mm Equipment (1935).
- (2) 16-Mm Spools, Reel Capacities, Sprockets, *etc.* (1937).
- (3) Recommended Procedure and Equipment Specifications for Educational 16-Mm Projection (1941).

Committee on Preservation of Film

- (1) Recommended Methods and Equipment (1933).
- (2) Film Handling and Storage (1940).

Committee on Sound

- (1) Frequency Reference Standard Film (1936).

Committee on Standards

(1) Numerous reports over period of years resulting in fundamental ASA Standards of Camera and Projector Gate Apertures, Sprockets, Film Cutting and Perforating, Sound-Track Positioning, Splices, *etc.*

Committee on Studio Lighting

- (1) Current Studio Lighting Methods (1937).

Committee on Theater Engineering

- (1) Projection Room Layouts and Specifications (1931).
- (2) Standard Visual and Sound SMPE Test Reels (1934).
- (3) Revised Projection Room Plans (1935).
- (4) 2000-Ft Reel (1935).
- (5) Tentative Recommendations for Screen Brightness (1936).
- (6) Revised Projection Room Plans (1938).
- (7) Proposed Revision Regulations, National Board of Fire Underwriters (1938).
- (8) Revised Projection Room Plans (1942).
- (9) Wartime Conservation in Theater Projection (1942).
- (10) Conservation, Civilian Defense and Screen Brightness (1943).

A number of these reports are of particular value as reference sources and as guides to recommended procedures. The Report on Preservation and Storage of Film serves as a reference for detailed information on the methods of preserving processed film and safe methods of storing it. The Report on Projection Room Plans has become practically a standard for specific data on the design, construction, and operation of a projection room. Combination Reports on the 2000-Ft Reel were instrumental in the acceptance of the 2000-ft reel as a standard mount for prints in practice. The Report on Recommended Procedure and Equipment Specifications for Educational 16-Mm Projection has served as a guide to educational and

industrial institutions as well as to the military and civil departments of the Government. The Report on Current Motion Picture Laboratory Practice, published in the April issue of the JOURNAL in 1936, is extensively used as a reference source for information on motion picture laboratory practice, type of equipment, film in general use, special processes, and procedures, *etc.*

Reports on Wartime Conservation in Projection Rooms, Civilian Defense in Theaters, and Screen Brightness have given specific details on ways and means of conserving prints and projection equipment, and have also given suggestions for consideration of any general changes in various types of equipment to be made to conserve film. A Report on Conservation of Film was published and reviewed about a year ago by the majority of motion picture trade papers. It is understood that this questionnaire type of report was so ably prepared that it served as a source of reference for judgment as to whether any advantages would be obtained in the conservation of motion picture film if major equipment changes were made in the exhibition phase of our industry.

(3) *Conservation.*—Much work has been done by the various technical committees on the conservation of equipment, film, general material, and accessories because of the wartime demand. Notable among these are: Reports on Wartime Conservation in Projection Rooms, Conservation and Civilian Defense in Theaters, Conservation of Film, Screen Brightness, Civilian Defense in Theaters, and Conservation in Sound Departments of Studios. While these reports and technical papers were initially prepared from study for conservation in wartime, their value will continue in the post-war period. Each will serve as recommended methods of operation, which increase efficiency and economy of time and material, that were not practiced or well known heretofore.

(4) *Planning.*—All technical or engineering committees are now actively making studies in their respective fields and will publish reports of these efforts when conditions permit. Studies are at present in progress on the design, construction, and operation of a motion picture laboratory, conservation in production technique, standardization of splicing and mounting film in exchanges, tests on projection sprockets to prolong film life, preparation of 35-mm and 16-mm sound and visual test reels, civilian defense in theaters, definition of motion picture terms, methods of measuring screen brightness, *etc.* These reports will not only give specific data regarding practical

or pilot tests that have been made, but will also give specific recommendations for design, construction, operation, and procedures.

CONCLUSIONS

In addition to these specific engineering projects of past and present performance as well as future proposed studies, it should be noted that the Society of Motion Picture Engineers is the only technical and scientific organization in the motion picture industry that has, and is regularly publishing, a monthly Journal which deals with the specific technical and engineering problems of our industry. It is important to note also that all of this work and its publication has been done for the past 27 years by the membership giving generously of its time without receiving any other reward than that of recognition for having done a good job.

The members of our Society have a right to be inordinately proud of the accomplishments to date, but our wholehearted application is now needed more than ever before. Within the past 3 weeks the Armed Forces of the United States have requested our Society to assist in the preparation of a group of specifications for general 16-mm motion picture production and equipment. This work has already been initiated through the Committee on Standards of our Society in conjunction with the Armed Forces, and perhaps by the time of the next conference details will be available about it.

DISCUSSION

MR. HUSE: Are any of the reports cited available in reprint form, or are they published only in various monthly JOURNALS?

MR. HYNDMAN: I do not have here a record of Society reprints now available. I believe most of those mentioned are available only in back issues of the JOURNAL. However, some of the reports, such as Projection Room Planning, American Motion Picture Standards, and SMPE Recommended Practices, are in reprint form and may be obtained from the office of the Society.

MR. HUSE: In view of the importance of properly handling and storing motion picture film, especially by the Armed Forces who do not always have adequate vaults or instructions for film care, it occurs to me that the Society should consider preparing reprints of, or republishing in the JOURNAL, the Report on Storage and Preservation of Film.

MR. HYNDMAN: If there is sufficient demand for such reprints, any of these reports can be prepared in booklet form and distributed generally throughout the industry.

MR. SPONABLE: What is being done by film manufacturers toward supplying raw stock on acetate safety base?

MR. CORBIN: Under war conditions it is improbable that this can be ac-

completed generally. However, since much of the film being supplied to and used by the Armed Forces is of the acetate safety base type, it is possible that this impetus may carry over into the post-war era.

MR. RYDER: The printed matter which has appeared in the JOURNAL relative to both film protection and acetate film is available to the public either at the Academy Library or at the Los Angeles Public Library and at the Society's offices in New York.

MR. GASPAR: Will it be possible to have the JOURNAL carry a list of the important reports cited by Mr. Hyndman?

MR. RYDER: I will bring the matter to the attention of the responsible parties in the Society.

MR. LESHING: What are film manufacturers doing relative to the future use of acetate base film?

MR. HYNDMAN: To the best of my knowledge all film manufacturers are interested in the general use of acetate base film when manufacturing capacities and the improved physical characteristics of the material will permit practical and economical production.

MR. CORBIN: Most of the film furnished to the Armed Forces is acetate or safety base, this includes both 35-mm and 16-mm film.

MOTOR SYSTEMS FOR MOTION PICTURE PRODUCTION*

A. L. HOLCOMB**

Summary.—The various types of motor systems and speed controls used in motion picture production are reviewed, evaluated, and the basic theory of operation described.

Motor drive systems are a fairly simple but important element in the production of motion pictures, but to many people who do not have direct contact with this phase of activities, the number of systems in use and their peculiarities are very confusing. Data on most of the different types of motors and motor systems in use have been published, but in different places and at different times so that no comprehensive reference exists. This paper is not intended as information on new developments or as a technical study, but rather as a review of all the major systems with an indication of their fields of greatest usefulness and with comments on both their desirable and undesirable features. To be complete, it will be necessary to cover some points that are common knowledge to many people in the industry.

The original motor drive for cameras was a battery-operated motor intended solely to relieve the cameraman of the mechanical function of hand cranking. This "wild" motor still survives and is used for silent shots and especially for underspeed or overspeed operation. It has been refined to provide ready adjustment of speeds over a wide range and in some cases to incorporate a tachometer which indicates in frames per second the actual film speed.

The advent of sound recording introduced an additional requirement since it became necessary to synchronize one or more cameras with a recorder, and still further complicated things by requiring that in some cases, as in dubbing, several different films must start, accelerate, and remain in synchronism. More recently, background projection has imposed a further demand since in this operation it is

* Presented May 7, 1942, at the Technical Conference in Hollywood.

** Electrical Research Products Division of Western Electric Company, Hollywood.

necessary that the shutters of cameras and the background projector be in phase as well as in synchronism. Also, the necessity for taking sound-recording equipment on location has introduced weight and bulk factors which demand a light and efficient system for this duty.

Several different motor systems have been developed or adapted to meet these particular needs, and various motor system speeds have been adopted by different studios to meet their specific conditions or desires, but it should be borne in mind that in all normal speed shooting the object is to move film past the translational point at 90 ft per minute, which in the case of cameras is 24 frames per second. This film speed requirement must always be met regardless of the motor speed used, and in most cases this is accomplished by interposing gears of the proper ratio between the motor shaft and the film-pulling sprocket. Practically all cameras are provided with a drive shaft that is designed to rotate normally at 1440 rpm, which is shutter shaft speed, and all camera motors which run at speeds other than 1440 rpm have the required gears built into the motor housing or adapter. In fact even the camera motors that run at this speed usually have 1:1 gears so arranged that the motor shaft may lie parallel to the shutter shaft for better compactness. Recorders and reproducers are usually equipped with built-in gears since the film-pulling sprockets are frequently different from those used in cameras in order to obtain uniformity of film travel, and in most cases the drive shaft is direct coupled to the motor.

The older Mitchell camera, which was equipped with ball bearings and is called the Standard Mitchell, requires from 25 to 40 watts shaft power to drive it at normal speed when the temperature is around 70°F. With lower temperatures, the power is somewhat increased but not seriously. The Mitchell *NC* camera, which is widely used at present, requires an average of 50 watts at 70°F, but since this unit is equipped with oilless bearings, the bearing friction rises sharply with lower temperature and while no exact data are available, observation would indicate that the load at 32°F is approximately 150 watts. Cameras have been successfully operated at much lower temperatures and the load appears to increase at about the rate indicated between 70° and 32°. Technicolor cameras demand normally about 100 watts and their power demand increases to approximately 350 watts at 25°F. Exact values can not be stated because bearing clearances differ in individual cameras of the same type. Sound recorders vary so widely in type that no attempt will be made to

enumerate power requirements in these machines, although in general it can be said that they fall between 75 and 125 watts at 70°. The variation in power demand with temperature is less than that noted for cameras owing to the use of ball bearings and better lubrication. Projection machines also vary widely, but will require an average of 150 watts driving power.

Since the power demand of cold machines is frequently much greater than in normal operation, it has been found desirable to supply motor drives whose maximum power output is approximately three

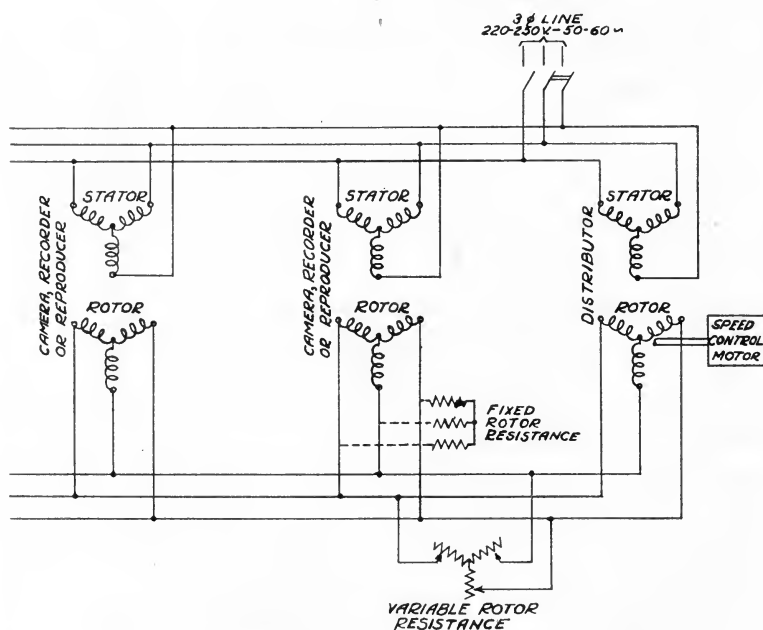

FIG. 1. A-c interlock system.

times that of the average demand. This power to load ratio seems large, but experience has indicated that it is necessary in order to prevent bad starts in cool weather.

A-C INTERLOCK SYSTEM (Fig. 1)

What has become generally known as the a-c interlock system was introduced to the motion picture field as part of the Western Electric sound system¹ and is known outside the sound-recording field as "Power Selsyn" motors. This system is a general purpose type that interlocks at standstill so that synchronizing marks can be made on

the film while the machines are at rest. Also when used in background projection the shutters of the various units may be adjusted alike and interlocked at standstill. Since the interlock is continuous from standstill to full speed and back to standstill again, the phase relation of shutters and the relative position of start marks on the films remain essentially the same throughout the whole cycle of operation. The system is inherently quiet, starts smoothly, and is particularly desirable for dubbing operations where it may be necessary to operate many reproducing machines together. The chief drawback of this system is its low over-all efficiency, which is not important for stationary use but becomes serious for portable work since the weight and bulk of a motor system and its associated power supply are inversely proportional to the efficiency. This system requires a distributor and some form of speed-controlled distributor drive motor which is usually of the vacuum tube control type, or, where a source of well-regulated power of the proper frequency is available, a synchronous motor may be used for combined distributor drive and speed control. The use of both these types of speed control motors is discussed later.

A further limitation of this system is the fact that sudden shocks, such as excessive acceleration during start, may cause a motor of the system to pull out of phase with the distributor and run away. Also, the synchronous tie between motors or between any motor and distributor is relatively loose. This characteristic is inherent in the distributed type of winding used in both rotor and stator. When the phase relation between machines must be maintained within close limits as in background projection,² it is necessary for the best results to use a motor whose power is large compared to the load which it is driving since the departure from a true synchronous position is proportional to the power of the motor and the load which it drives.

An a-c interlock system is shown schematically in Fig. 1. These motors are wound with a standard three-phase distributed winding on the stators, and as in conventional practice, this winding may be designed for two, four, six, or any other desired even number of poles. The rotor winding is essentially similar to the stator winding except that enough turns are added per coil to produce a 1:1 voltage ratio when the stator is excited and the rotor is at standstill. The windings of the rotor are brought out through slip rings and associated brushes. It is customary to star connect both rotor and stator internally. The stators are connected for operation to a three-phase

line of 220 to 250 volts, 50 or 60 cycles, which produces a rotating magnetic field in the stator. If the rotor leads are shorted, the motor will run as an induction motor, or if a variable resistance is connected across the rotor leads, an unloaded motor may be made to run at any speed desired up to approximately 95 per cent of synchronous speed, although the regulation is poor as would be the case in any standard wound, high-slip induction motor. When it is desired to operate motors in interlock, the leads from all rotors are connected in parallel; then if a single phase of all stators is excited, voltages will be induced in the rotors which cause currents to circulate between the windings of different motors and which set up polarities that tend to pull all rotors into the same position relative to the excited phase of the stators. When this is achieved, the voltages induced in any rotor balance the voltages induced in all other rotors and no further exchange of current takes place. If the same phase of all stators has been excited, then the rotors will be aligned with each other and are held definitely in this position, which is generally called the "interlock" position. When the third phase of the stator is excited, a rotating magnetic field, as previously noted, is produced in the stator, but the rotors being aligned with each other, the voltages induced are still equal and unless there are serious iron or other parasitic losses in the rotor, the motors have no tendency to rotate. If the rotor of any motor is moved mechanically, the balance between rotors is disturbed and again current is interchanged to bring other rotors to the position of equilibrium. This adjustment is practically instantaneous, and if the rotor of one of the motors is continually rotated, the following action of other rotors is also continuous.

The largest motor in the system is called the distributor and differs from others only in size and power capacity and this larger unit is normally connected to a driving motor whose speed is rigidly controlled. Thus all motors in the system are locked together and rotate at a constant speed which is determined by the controlled distributor motor. Motors may be operated in either direction without changing the direction of the rotating magnetic stator field, but normally the direction of mechanical rotation is the same as the rotating field in order to obtain a portion of the total required power from the induction motor action by applying resistance across the rotor circuit. In some cases this resistance is applied in the form of a variable three-phase rheostat which permits any desired amount of power to be taken from the three-phase line, or in other cases a fixed resistance

is shunted across each phase of the motor at each machine so that the induction motor action of each individual unit is sufficient to drive its associated load at approximately three-fourths of normal speed. Thus the control motor is only required to furnish sufficient power to maintain speed regulation regardless of the number of connected motors. This permits the use of speed control motors which are small compared to the load carried by the system. However, excessively low values of resistance tend to reduce the synchronous tie between

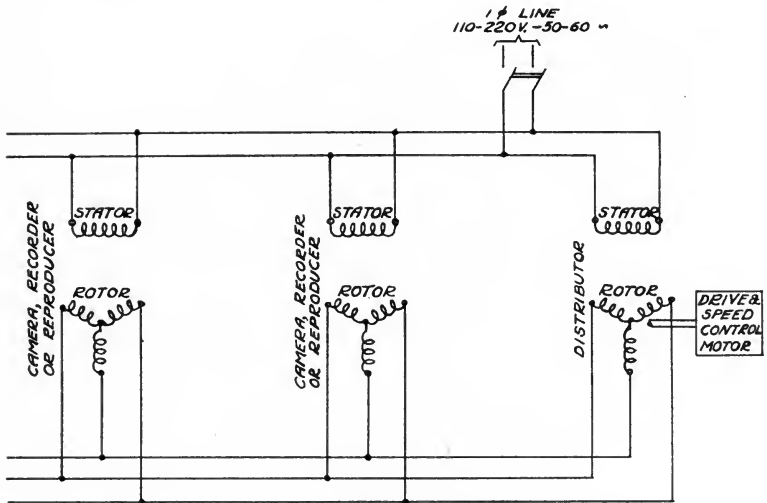

SINGLE PHASE SUPPLY WINDING MAY BE
DESIGNED FOR EITHER ROTOR OR STATOR

FIG. 2. Selsyn motors.

motors and consequently there is a limit to the power that can be obtained in this way.

All motors must first be aligned single phase since when they are thrown together the position of the rotors in the system is random, and if rotors are out of phase with each other, each acts as a short circuit on the other rotors when the stators are excited with three-phase. Under this condition all motors act as individual induction motors and produce what is commonly called a "runaway." The single-phase excitation, however, does not produce a rotating field and therefore rotors align themselves from any position without tending to run. The direction of rotation of any motor may be reversed

by reversing any two leads in the rotor and any two leads in the stator. However, the relative interlock position may change when the motor is reversed, and while this is immaterial under most conditions, in background projection it may have the effect of disturbing the shutter phase relation by a like amount. A two-pole switch in any two rotor leads may be used to disconnect motors from the system if it is inconvenient to disconnect all six leads. Disconnecting the stator leads while leaving the rotor connected to the system is undesirable and will usually cause runaway since the rotor once out of step becomes a low impedance across the line.

For most types of duty, the ratio of power to normal load should be at least 3:1 and probably about 5:1 for background projection. This is necessary not only to insure sufficient power for operation, but also because some of these motors become unstable and show a tendency to hunt when operated close to their pull-out load. The speed of the driven motors is determined solely by the distributor speed, not by line frequency, and this speed may be anything up to within about 10 cycles of synchronous speed. Standard distributors are four-pole and a large proportion of them are driven at 1200 rpm, while most motors in the field are either two- or four-pole. The speeds most used are as follows:

Two-Pole	Four-Pole	Stator Excitation
2400 rpm	1200 rpm	50- or 60-cycle
1440 rpm	720 rpm	50- or 60-cycle
2880 rpm	1440 rpm	60-cycle only

SELSYN MOTORS (Fig. 2)

The name "Selsyn" is a General Electric trade name derived from "self-synchronizing," although the term is widely used on motors other than those manufactured by General Electric. These motors are used to a limited extent in motion picture production. The system as shown in Fig. 2 is essentially similar to the a-c interlock system except that the stator is excited with single phase. Either rotor or stator may be designed for the single-phase exciting winding with the other element in each case carrying a three-phase winding. The application of this system is similar to that of the a-c interlock. The motors interlock at standstill and can thus be used for background projection, dubbing, *etc.* They have the advantage that unless operated close to synchronous speed, the danger of running away is

much less, but have the disadvantage that practically all power for the system must be derived from the motor driving the distributor which must thus have sufficient power for this purpose as well as speed control. The motors are also slightly larger for a given power output because the single-phase exciting winding is inherently less efficient than a three-phase winding.

As previously noted, the connections shown in Fig. 2 are essentially similar to those in the a-c interlock system, all stators being supplied from a common single-phase source in this case and all rotors connected in parallel. The single-phase source is usually 220 to 250 volts and may be either 50- or 60-cycle. Alignment and operation

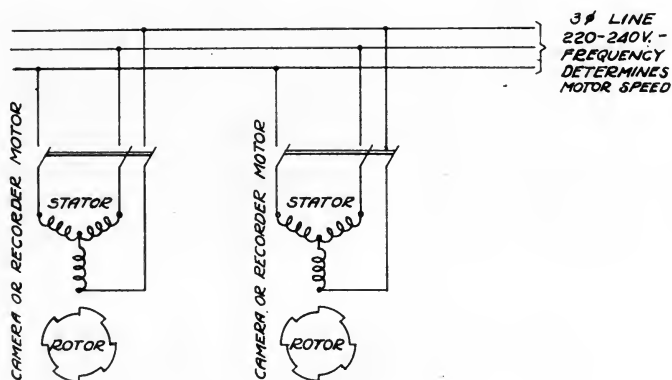

FIG. 3. Synchronous motors.

are similar to the a-c interlock system except that no secondary resistance can be used to advantage since there is no rotating magnetic field in the primary winding. Therefore, no induction motor action takes place until motors are close to synchronous speed. Motors may be run in either direction and at any speed with essentially the same restriction as the a-c interlock, *i. e.*, that they are not called on to operate closer than 10 cycles to synchronous speed. To reverse the direction of rotation of a motor, it is only necessary to reverse any two of the three-phase rotor leads.

Selsyn motors are used extensively in small sizes for indicators and remote controls and are frequently used for focusing cameras in sound-proofed housings where the focusing mechanism is mechanically inaccessible from outside:

SYNCHRONOUS MOTORS (Fig. 3)

When a supply line with a stable frequency is available, both power and speed control may be obtained by the use of synchronous motors. These motors may be either single-phase or three-phase, but inasmuch as single-phase motors are almost twice as large for a given power output, single phase is seldom used in sound recording. In the Los Angeles city limits the power line supply is 60 cycles at 240 volts and the frequency control and stability are excellent. The total departure from 60 cycles is seldom more than 0.25 of 1 per cent and the rate of departure from the ideal is not great enough to be of consequence in sound recording. Outside Los Angeles city limits, the power supply in this area is of 50-cycle frequency supplied by Southern California Edison lines and, while probably adequate for sound recording under normal conditions, the frequency control as measured four years ago was not so good as that of the present 60-cycle line and showed departures as great as 0.6 of 1 per cent, sometimes at a rate which was audible. It is possible that the frequency regulation of the Edison lines may have improved in recent years.

Synchronous motors as used in sound recording are not the conventional synchronous type since the usual synchronous motor requires d-c excitation for the fields. Motors in use for this duty are practically always of the variable reluctance type which is ideal for stage use on original recordings, since the motors can be started and stopped independently, do not require a central distributor or control motor, and provide very quick starting with attendant economy of film during the acceleration period. They require a minimum of maintenance since they have no moving contacts. Probably the most serious difficulty in this type of motor is that the starting shock is high unless some form of slow speed start is incorporated in each motor circuit. The power factor at which they normally operate is relatively poor, consequently, the current demand for a given power is high and the operating efficiency is seldom more than 20 per cent or 25 per cent. This fact requires a motor of larger size than if the power factor and efficiency were more nearly optimum. Also, the motors inherently have a high magnetic noise level. Unlike the Selsyn or a-c interlock system, they do not synchronize with each other until they have reached full speed and therefore require some form of running synchronizing mark which, in its simplest form, is put on the films by a hand clap in front of the cameras, the sound being picked up and recorded on the sound-track in a form that is

readily located by the cutters. Various other synchronizing or "bloop" marks have been developed and used for this duty. Since the motors do not interlock at standstill, they are not used on background projection or for dubbing duty. The relatively low efficiency is of no consequence for stationary or stage use, but becomes a factor for location work and, like the a-c interlock, is not the optimum type of system for portable use since the usual source of power on location is batteries. For this purpose, synchronous motors require a motor generator set or an inverted converter to produce the alternating three-phase supply. Motor generator sets are generally preferred for this duty due to their better regulation and stability even though the inverted converter is a more efficient unit. The inverted converter is unstable for the reason that its speed varies with the power factor of the connected load and unless some form of automatic speed control is used, it is not normally satisfactory as a stable source of frequency. However, the over-all efficiency and weight of a synchronous motor system for location duty are better than that of the a-c interlock system.

The variable reluctance synchronous motor is essentially a standard three-phase stator with a low-slip squirrel-cage rotor which has been slotted for about 50 per cent of the pole arc and approximately $\frac{1}{8}$ in. deep. The number of salient poles in the rotor will, of course, be the same in all cases as the number of poles in the stator winding. When the motors are thrown on the three-phase line, the squirrel-cage copper in the rotor starts the unit as an induction motor. The resistance of the squirrel-cage is purposely made very low in order to bring the rotor close to synchronous speed. Having approached closely to synchronous speed as an induction motor, the rotating magnetic field of the stator pulls the salient portion of the poles into the region of maximum flux density because the air gap reluctance is much greater in the slotted section. Thus the rotor is carried around with the rotating field at synchronous speed as though the rotor were a simple iron bar. The squirrel-cage copper does not contribute to the power of the motor after it has reached synchronism but does provide excellent damping. Motors will usually carry much greater loads after they have synchronized than they will pull into synchronism. They are commonly wound and slotted for 2, 4, or 6 poles, but may be designed for any desired even number. Four-pole motors are probably more used than any other, although a great many six-pole units are used on 60 cycles to drive recording machines and also

as speed control motors for the a-c interlock system. The following is a list of the most used frequencies, number of poles, and resultant motor speeds:

	60-Cycle	50-Cycle	48-Cycle
Two-pole.....	3600 rpm	3000 rpm	2880 rpm
Four-pole.....	1800 rpm	1500 rpm	1440 rpm
Six-pole.....	1200 rpm		

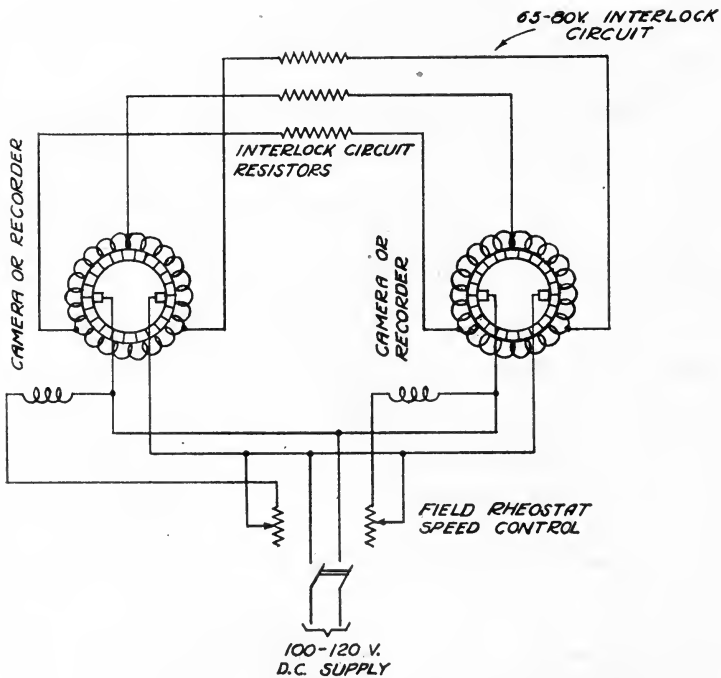

FIG. 4. Original d-c interlock system.

ORIGINAL D-C INTERLOCK (Fig. 4)

As soon as sound-recording units were used on location work, it became apparent that the ideal motor system for this duty was one which required a minimum number of units and which could operate directly from a battery. Thus the weight and bulk of converter, distributor or motor generator units could be eliminated and the improved over-all efficiency would reduce the size of the required

battery. As a result, a number of different people apparently conceived the idea of driving direct-current motors from a battery and tapping the commutators of these motors at three points, thereby making them essentially inverted converters, using the derived three-phase output to interlock the motors to each other. Thus the relatively high efficiency of a battery-operated d-c motor could be obtained as well as interlock between motors. This had the desired feature of eliminating central distributor or generating units with their attendant power losses and provided a relatively simple and flexible system. Like synchronous motors, the d-c interlock does not synchronize at standstill and requires a running bloop. The interlock frequency will be determined by the speed and the number of poles. In actual operation this system has not been completely satisfactory because of high commutator maintenance and relative instability of interlock.

The manner in which interlock is obtained is as follows: current in the armature coils of d-c motors is reversed by the commutator and brushes as each coil passes from one pole to the next which is of opposite polarity. Thus the current and voltage in the coils alternate at a rate which is determined by the speed and number of poles. If these coils are tapped at three points 120 electrical degrees apart, the alternating potential appearing at these points may be used for an external three-phase circuit and since the coils terminate at the commutator bars, it is entirely feasible to make connections there. Thus by the addition of slip rings and brushes to a standard d-c motor, a converter type d-c interlock motor is produced. If the field resistances of two such motors are adjusted until the motor speeds are alike, then the three-phase leads may be interconnected and motors should run in synchronism, interchanging only enough current to hold in step. However, where a common d-c supply is used, motors may not be in phase at start or at the time they are thrown together, and it will then be apparent from Fig. 4 that it is possible for a tap on one commutator to be under a negative brush and the tap connected to the same lead on another motor to be under a positive brush which short circuits the power supply through the brushes and commutators but does not produce any synchronizing effect.

The most obvious remedy for this out-of-phase short circuit is to introduce sufficient resistance in the three-phase leads to limit the current to a safe value under this condition. However, in practice the amount of resistance necessary to keep commutator maintenance

to a desirable level is also high enough to materially reduce the amount of current that can be interchanged between rotors operating in interlock. This reduces the interlock torque with attendant instability or tendency to hunt, and thus the optimum value of resistance is a compromise between commutator maintenance and stability. The effect of out-of-phase short circuiting can be eliminated by using a separate power supply for each motor, but unfortunately, the effective voltage derived for three-phase interlock on this type of motor is approxi-

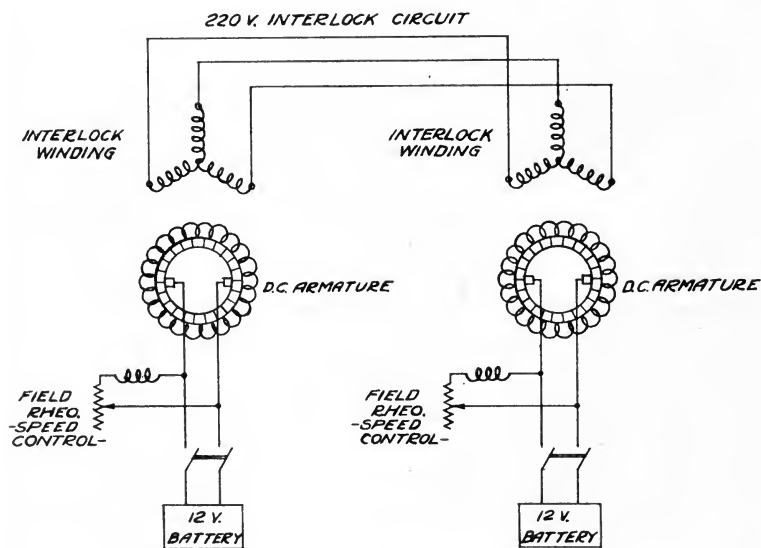

FIG. 5. 12-volt d-c interlock system.

mately 61 per cent of the applied d-c voltage. The use of individual low voltage d-c batteries is thus undesirable because of the still lower interlock voltage and the use of several high-voltage batteries is not practicable because of weight and bulk. Thus the original d-c interlock system was and is a usable system for portable duty, but with inherent faults which prevent it from being completely satisfactory.

12-VOLT D-C INTERLOCK SYSTEM (Fig. 5)

A further development in portable systems was provided by the 12-volt d-c interlock system³ in which a separate three-phase winding was introduced in the same slots of the rotor that were used for the

motor windings. Since the windings are only inductively coupled, they may be designed for any voltage of either the three-phase interlock circuit or the motor driving circuit. Thus it is possible to operate a motor on 12 volts d-c and obtain a separate 220-volt a-c circuit for interlock. While the separation of windings eliminates the short-circuit difficulties incurred in the original system when operated from a common power supply, it was felt that the improved ratio of watt hours per lb in a 12-volt battery, with attendant reduction in weight for a given power capacity, was a factor worth consideration in portable systems. Also, the use of individual batteries at each motor automatically expanded or contracted the power supply capacity with the number of motors in use, thereby eliminating the necessity of carrying a central battery large enough to supply the maximum possible number of motors at all times. Twelve volts was chosen as the best battery voltage because this voltage is commonly used for amplifier and lamp supply. Thus the same battery could be interchangeably used for either duty.

A further advantage of the individual supply was the fact that only interlock current at high voltage was carried in interconnecting cables, which made possible further standardization of equipment since the small cables normally used for speech duty could also be used to interconnect motors. The use of double windings, however, requires a larger motor for the same speed and power and the interlock winding, of necessity, is designed to have a capacity of only about one-fourth of the total motor power. This requires that the motor be adjusted within 100 rpm of its normal speed before being interlocked. The most serious objection that this system developed in the field was due to the use of a battery at each motor as some cameramen object strenuously to the additional equipment under foot at the cameras. A running bloop is required for this system also, since the motors do not interlock at standstill. In the field it has proved to be a good practical system for portable duty.

The mode of operation is as follows: the units operate essentially as 12-volt d-c motors whose speed can be adjusted by means of a field rheostat. The high-voltage three-phase winding is brought out through slip rings and connected to the same circuit on other motors. In operation the interlock windings of each motor appear to other motors as alternating-current generators or synchronous motors running in parallel. The impedance of the three-phase windings is purposely high enough so that even though motors are thrown together

out of phase, no serious sparking occurs at the brushes. Sufficient damper copper is introduced in the d-c field structure to damp out hunting tendencies which are always present in any motor receiving power from two different sources. As operated they can be controlled either locally at each motor or from a central control. They can be designed for any voltage or interlock frequency, although it has been standard practice to use a 60-cycle interlock frequency so that, if desired, the interlock circuit can be connected to a 60-cycle supply line for speed control.

A further type of operation to which this system lends itself is miniature background projection. This type of work calls for camera speeds as much as four times normal in some cases, which is higher than can be readily obtained from the a-c interlock or Selsyn. The standard two-pole motors drive the cameras through a 1:1 gear coupling or direct on the shutter shaft. A 24-volt battery is used which is tapped at every cell from 6 to 24 volts and all motors may be operated on one battery if desired. The motors on cameras and projector can be started and interlocked on 6 volts and then brought up to the desired speed range by increasing the supply voltage *via* the battery tap switch; speed may then be finally adjusted by means of the field rheostats. Starting shock to cameras and projector is thus avoided and the system may be operated at any desired speed up to 100 frames per second. Since the motors are two-pole and run at shutter shaft speed, they will always interlock in the same relative position and the shutters will always be in phase.

Standard motor speeds are as follows:

Two-pole.....	3600 rpm
Four-pole.....	1800 rpm
Six-pole.....	1200 rpm

MULTI DUTY MOTOR SYSTEM (Fig. 6)

A further development in motor systems was described in a paper presented at the fall meeting of the SMPE, in 1939,⁴ which incorporated in one motor system the desirable features of both the d-c interlock and synchronous motors with the further ability to be interlocked at standstill. Since this paper was presented, several important improvements have been made in this system. As described, the d-c interlock operation on the common 96-volt battery required the use of ballast lamps in the interlock circuit to prevent

out-of-phase short circuits, and for synchronous operation a transformer was required to reduce the standard 220–240 volts to a nominal 65 volts. The motors as originally designed had approximately 50 per cent more power as d-c motors than they did as a-c synchronous motors and it was found that by reducing the maximum d-c capacity to that of a-c operation (200 watts) that booster windings could be added without increasing motor size if the position of coils were properly chosen. This brought the three-phase voltage up to the

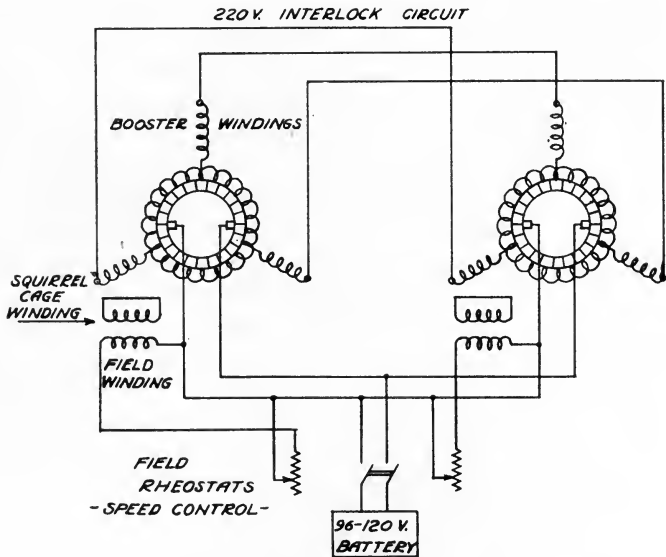

FIG. 6. Multi-duty system, d-c operation.

standard 220 volts, thus permitting synchronous operation on a supply line without the use of a transformer. It was also found that the inductance of the booster windings eliminated the necessity of ballast lamps or other forms of external current limiting devices for interlock operation which made the motors much more flexible and “foolproof” in operation. The higher voltage on the a-c circuit also permitted the use of cables of higher resistance, thereby reducing either the size of the cables or increasing the operating length. Another desirable feature obtained was the ability to interlock two motors at standstill without the use of a distributor or inverter as previously described in the SMPE paper. Thus the system became still more an all-purpose

system than before, providing a high power factor synchronous motor for stage use, and an efficient d-c interlock motor for location duty, which, if necessity arises, can be interlocked at standstill without additional equipment and which can be individually or centrally controlled as the studio preference may dictate. These motors may be designed for any voltage or speed, but 96 volts d-c has been selected because of the fact that such a battery may be charged from a standard 120-volt lighting generator without the use of resistors or special switching equipment. The standard speeds have

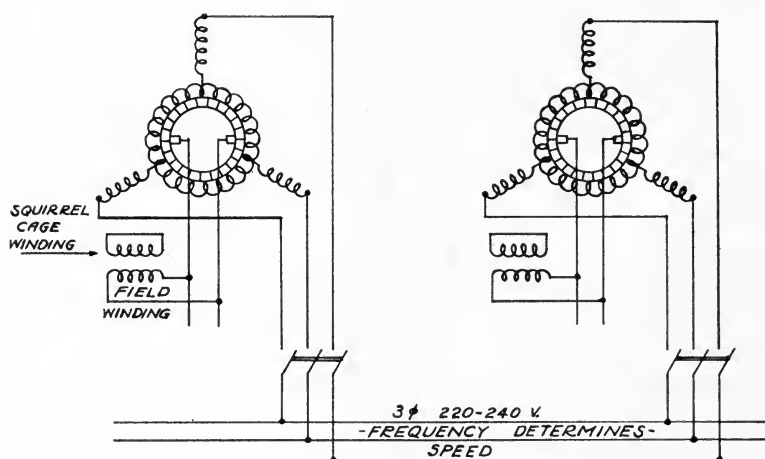

FIG. 7. Multi-duty system, synchronous operation.

been set up to provide 24-, 48-, and 60-cycle interlock or synchronous frequency.

The mode of operation for d-c interlock of the improved system is shown in Fig. 6 and is essentially similar to the operation described for the original d-c interlock except that the booster windings generate voltage as they run which is additive to the converted voltage appearing on the d-c winding at the tap points. The protection against short circuits due to out of phase is provided by the fact that this short-circuit current must pass first through the booster windings which present a considerable impedance to instantaneous surge current and prevent it from reaching a destructive value, and which at the same time produces a synchronizing torque that pulls the rotor into phase before the inductive limiting effect has disappeared.

Experimentally, motors have been thrown together when their operating speeds were adjusted to be as much as 2000 rpm apart, and even under this extreme condition, they synchronize without serious sparking at the commutator. As in the 12-volt d-c interlock system, speed control may be obtained by connecting the interlock circuit directly to a 220-240-volt line of the proper frequency.

Operation as synchronous motors is shown in Fig. 7 in which the field windings are connected across the armature. When the three-phase line circuit is closed, the damper copper in the field starts the unit as an induction motor similar to the action described in the variable reluctance synchronous system. However, in addition to the variable reluctance action, which in this case is provided by the salient d-c poles, a further synchronizing torque is obtained from the d-c winding on the poles due to their self-excitation and the fact that properly connected, the polarity of these poles can be made to automatically reverse at the proper time to aid pull-in to synchronous speed. This additional synchronizing torque effectively doubles the load which a given size of motor is able to synchronize. Once in synchronism, the self-excited d-c field provides a relatively high field flux density which, in turn, produces a good power factor and sharp synchronous coupling. Read and Kellogg⁵ state that the use of a self-excited field winding in this manner is undesirable due to a tendency to hunt. This is quite true in a motor of conventional field structure, but by proper design, adequate stability can be provided while at the same time the desirable features of high synchronizing torque for a given motor size and good power factor are obtained. As in the original d-c interlock, it is desirable that the power supply should be of relatively high voltage and this dictates the use of a central power source rather than individual batteries.

To interlock any two motors from start, they are first aligned either manually or electrically by applying direct current to the fields and also to the three-phase interlock leads. Manual alignment requires only that a synchronizing mark be placed on the handwheel and stator of each unit so that the operators may turn each motor to the same relative electrical position. If then the interlock circuit is connected normally and d-c applied to the armature, the motors will come up to speed in interlock because the three-phase leads are directly connected through the booster windings to the d-c source, and thus voltage appears immediately across the interlock circuit as soon as it is applied to the armature and holds all units in step during the initial accelera-

tion period. Unless motors are first aligned, they may slip with relation to each other by several poles before synchronizing. This mode of operation is intended only to provide a method whereby interlock from standstill can be provided in an emergency without additional equipment and is probably not so reliable as the inverter-distributor method described in the previous paper.⁴ When connected for d-c interlock, this system will work on background projection as described under *12-volt d-c Interlock* providing two-pole motors are used running at shutter shaft speed. Multi-head projectors can be manually aligned with each other and thus interlock from start.

The standard motor speeds available at present are as follows:

	60-Cycle	48-Cycle	24-Cycle
Two-pole.....	3600 rpm	2880 rpm	1440 rpm
Four-pole.....	1800 rpm	1440 rpm	720 rpm
Six-pole.....	1200 rpm		

SPEED CONTROLS

Uniform speed is essential in sound systems both for recording and reproduction. To obtain speed control, four basic methods have been used: manual control with a constant voltage supply from batteries, automatic speed adjustment, synchronous control from line frequency, electronic speed control, and centrifugally governed motors.

MANUAL CONTROL

Since the load of recorders and cameras is essentially constant when running, the motor speed will be reasonably constant when the motor is supplied with constant voltage. Batteries provide a satisfactory source of constant voltage and motors thus operated are sufficiently stable for dialog and sound effects. Some speed variation will occur due to slow changes in battery voltage, to the fact that the load decreases slightly as machines warm up, and to the heating of the motor fields which increases their resistance and thus increases the speed. However, all of these variables appear at a slow rate not noticeable in dialog. A further advantage of this method of speed control is that the speed may be set at anything desired within the limitations of the motors in use. This method is largely employed for location work both on d-c interlock and for synchronous speed control on location where synchronous motors are driven from manually controlled motor generator sets.

AUTOMATIC SPEED ADJUSTMENT

Automatic speed adjustment may be used as a refinement of manual control for operation from a battery power source. This method provides a slow automatic adjustment of motor speed to correct for the slow variations encountered as noted previously. Several circuits have been devised for this duty, but, so far as is known, none are in use at this time.

SYNCHRONOUS CONTROL

Synchronous control by line frequency is excellent in most cases and automatic. The chief objections to synchronous speed control are that it does not permit under or overspeed operation and since all studios do not have the same power line frequency, it is difficult to interchange equipment. As previously noted, synchronous speed control on location or away from supply lines is not ideal because of equipment weight. One advantage of this speed control is that synchronous operation may be had at widely separated points provided these points are on the same supply line, thus making it possible to make parallel recordings for test or other purposes with no other requirement than that of a high-quality speech transmission line. Since the advent of well-regulated 60-cycle supply in Hollywood, a large number of six-pole synchronous motors have been used to drive 1200-rpm distributors in a-c interlock systems. In addition to being a desirable type of speed control for the a-c interlock system, it also makes possible the use of synchronous camera motors on the stages in conjunction with a-c interlock recorder or projector motors. The only undesirable feature of synchronous speed control motors as distributor drives is the fact that the starting shock and rate of acceleration are undesirably high. Since the a-c interlock motors can be shaken loose from the distributor by sudden shocks, it is necessary to incorporate some method of reducing this effect on distributor motors. The use of large flywheels on the motors prevents excessive shock to the distributor, but unfortunately also prevents the motor from synchronizing. Various start circuits have been devised such as the variable core reactors used by RCA and other means of varying line impedance by time delay or current-actuated relays. All of these methods are reasonably successful, but not completely satisfactory due to the fact that while the starting shock can be reduced to a satisfactory value, the rate of acceleration just prior to synchronizing remains undesirably high regardless of the start circuit. While not

extensively used, it seems probable that the Dixon Centrifugal clutch provides the most satisfactory approach to the problem since it permits the synchronous drive motor to synchronize immediately and before the distributor is started. Thus the rate at which the motor accelerates is immaterial. By providing an adequate flywheel on the distributor, the rate at which the distributor accelerates can be held within desirable limits regardless of the connected motor load. Since the synchronous motor is permitted to synchronize without the flywheel, the previously noted drawback to a flywheel is eliminated.

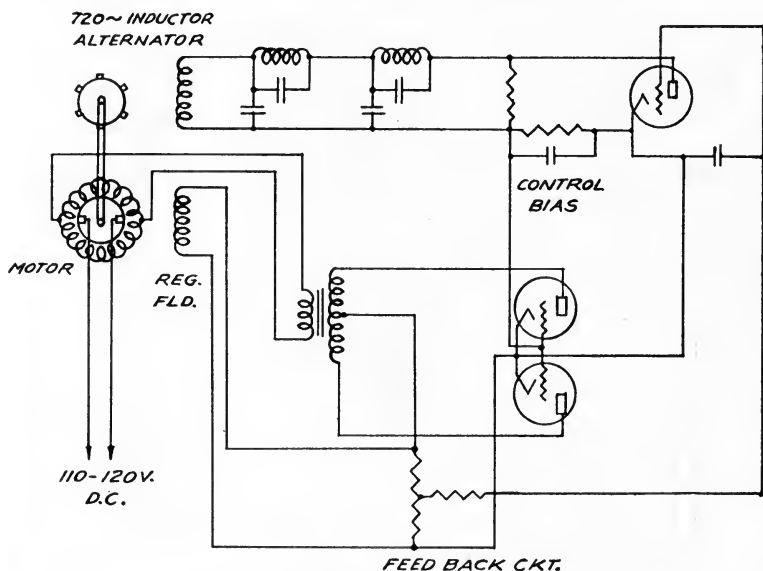

FIG. 8. Electronic speed control, d-c.

ELECTRONIC SPEED CONTROLS

Electronic speed control is relatively old in the industry,¹ but still widely used and has the virtue of being independent of supply line frequency and essentially independent of voltage and load. The regulation obtainable is as good as or better than that obtained from the 60-cycle line. Acceleration of motors can be varied to meet individual requirements. In most cases a switch is provided for manual control which permits under or overspeed operation with the system as well as emergency control in case of failure of the automatic circuits. The most used type for recording is the Western Electric

700-A cabinet which was developed by the Bell Telephone Laboratories and is shown in simplified schematic form in Fig. 8. This unit is designed to operate on direct current at voltages between 105 and 135 volts, and controls either the $\frac{1}{2}$ -hp motor (KS-5235) or the $\frac{1}{5}$ -hp motor (KS-5095), both of which are 1200-rpm motors and intended to be direct connected to a four-pole distributor. This cabinet controls motor speeds by varying the current in a high-impedance field winding in the motor. An inductor generator driven by the

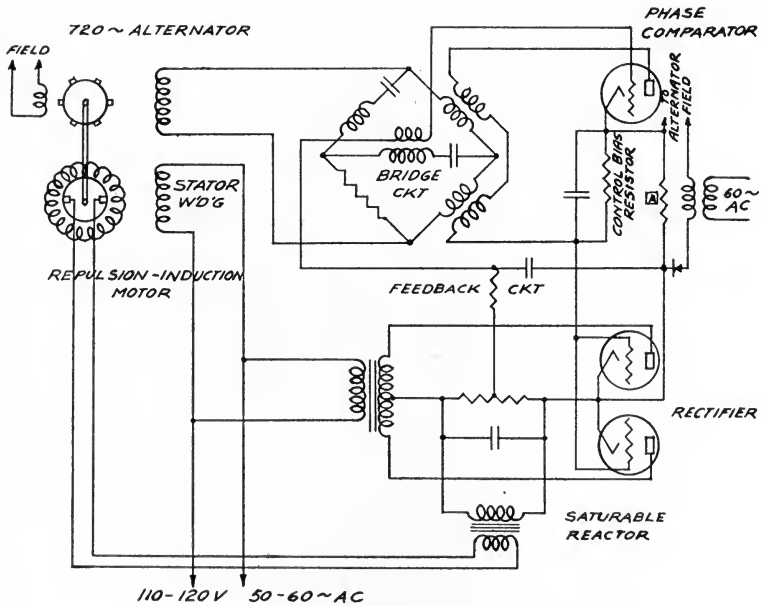

FIG. 9. Electronic speed control, a-c.

motor delivers a nominal frequency of 720 cycles to the cabinet through a sharply tuned filter, and since the frequency of the alternator varies with the motor speed, the output voltage of the filter also varies with motor speed. This output voltage is rectified and, in turn, varies the grid bias on pushpull rectifier tubes which supply the high-impedance regulating field. A feedback circuit intensifies the regulating effect to a point which would cause it to be unstable and hunt except that a slight time delay is incorporated in this circuit which permits adequate sensitivity without hunting. These units

are especially desirable for distributor drive where the line frequency is 50 cycles which does not lend itself to direct connection of synchronous control motors. While this speed control is used on many of the older location trucks, it is too heavy and bulky for lightweight portable units.

Another type in use is the *708-A* cabinet, Fig. 9, which is designed to control a $\frac{1}{8}$ -hp (*KS-5161*) motor and operates on 110–120-volt alternating single-phase supply of 50 or 60 cycles. A 720-cycle pilot generator works into a bridge circuit, one leg of which is tuned so that the voltage across the midpoint of the bridge changes phase with change in pilot frequency. This midpoint voltage is applied to the grid of a vacuum tube whose plate supply remains in phase with the generator. Thus the phase relation of grid and plate changes sharply with change in motor speed. The resultant plate current of this tube is used to bias two pushpull rectifier tubes whose d-c output saturates the core of a transformer, the secondary of which is in series with the motor rotor. The motor is of the repulsion type whose speed varies with the impedance of the rotor circuit and thus the speed of the motor is governed by the saturation of the coil in series with it. The control range of this unit is not so great as that of the *700-A* cabinet and it is used chiefly for review rooms and theaters. Its chief virtue lies in the fact that it requires only a standard single-phase 110–120-volt a-c supply and is essentially independent of voltage and frequency variations. A variant of this control method has been used for a lightweight control cabinet for the 12-volt d-c interlock system.

CENTRIFUGALLY GOVERNED MOTORS (Fig. 10)

Centrifugally governed motors control speed by opening and closing a contact in parallel or in series with a resistor in the field circuit of the motor. This contact is controlled by a centrifugal mechanism mounted on the shaft of the motor and can be made sensitive enough to open and close some 150 to 800 times per second, depending on the speed of the motor to which it is attached. If the field resistance is in series with the field, then the motor will tend to run faster when the contact is opened and slower when closed. If the field resistance is such that the fast speed is higher than desired and the slow speed less than desired, then the centrifugal contactor will alternately attempt to underspeed and overspeed the motor, but if the rate at which it makes contact is sufficiently rapid, the motor will never attain either limit but effectively vibrate in speed about a

mean point. The actual variation is very small and a well-adjusted governor will maintain speed within 1 per cent. The regulating range available is determined by the value of resistance which the contact controls, the larger the resistance the greater the control range. However, the optimum precision of control is best with small

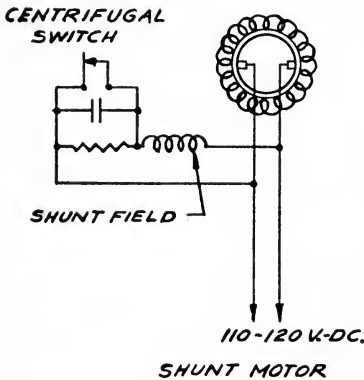
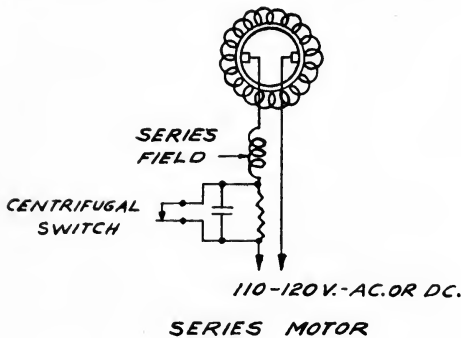

FIG. 10. Centrifugally governed motors.

values of resistance and high-motor speeds. Thus the optimum resistance must be a compromise between regulating range and a value which is small enough not to introduce flutter in a sound-recording system. The addition of a flywheel on the motor to iron out undesired fluctuation can not be used to any extent since it produces a "galloping" effect that is even more objectionable than the fluctuation it is desired to correct. The contacts of the switch are to some extent at all times and may stick momentarily, which introduces an element of uncertainty for sound recording that is not usually considered desirable. As far as is known, these speed control units have only been used for location work and it seems probable that for this duty manual control from a battery source is safer. While this type of control offers the maximum in weight and simplicity, at this time it is not completely satisfactory although it seems probable that in some form it may eventually provide the ideal portable speed control.

values of resistance and high-motor speeds. Thus the optimum resistance must be a compromise between regulating range and a value which is small enough not to introduce flutter in a sound-recording system. The addition of a flywheel on the motor to iron out undesired fluctuation can not be used to any extent since it produces a "galloping" effect that is even more objectionable than the fluctuation it is desired to correct. The contacts of the switch are to some extent at all times and may stick momentarily, which intro-

CONCLUSION

The following table presents an outline of the best type of motor system for various services:

STAGE OPERATION

- (1) Synchronous motors (multi-duty or variable reluctance type).
- (2) A-c interlock.

LOCATION

- (1) D-c interlock (multi-duty or 12-volt d-c interlock).
- (2) Synchronous (M. G. set driven by batteries).
- (3) A-c interlock (3-phase supply from converter and batteries).

BACKGROUND PROJECTION

- (1) Multi-duty, 24-cycle.
- (2) A-c interlock.

RE-RECORDING

- (1) A-c interlock.

ALL PURPOSE

- (1) Multi-duty.
- (2) A-c interlock.

REFERENCES

¹ STOLLER, H. M.: "Synchronization and Speed Control of Synchronized Sound Pictures," *J. Soc. Mot. Pic. Eng.*, **XII** (Sept., 1928), p. 696.

² TASKER, H. G.: "Improved Motor Drive for Self Phasing of Process Projection Equipment," *J. Soc. Mot. Pic. Eng.*, **XXXVII** (Aug., 1941), p. 187.

³ DAILY, C. R.: "A New Western Electric Double Film Portable Sound Recording System," *J. Soc. Mot. Pic. Eng.*, **XX** (Feb., 1933), p. 128.

⁴ HOLCOMB, A. L.: "A Multi-duty Motor System," *J. Soc. Mot. Pic. Eng.*, **XXXIV** (Jan., 1940), p. 103.

⁵ READ AND KELLOGG: "Stability of Synchronous Motors," *J. Soc. Mot. Pic. Eng.*, **XXXVI** (May, 1941), p. 514.

A REVIEW OF HYPO TESTING METHODS*

J. I. CRABTREE, G. T. EATON, AND L. E. MUEHLER**

Summary.—*The degree of washing of photographic films and prints is usually determined by estimating the hypo content of either (a) the photographic material, (b) the wash water, or (c) the drippings collected from the material. Various hypo testing methods are described including the use of either potassium permanganate, iodine, mercuric chloride, silver nitrate, or electrical conductivity measurements.*

It is shown that chemical or electrical measurements of the hypo content of wash water, or drippings from washed photographic materials, do not give an accurate indication of the quantity of residual hypo in the film or print but may be used for control purposes with continuous processing machines.

Spot tests made on the surface of the material with iodine solutions, e. g., iodine-azide-starch, are not easily reproducible with respect to the ratio of the volume of test solution to the area of the film or print to which it is applied.

Bathing tests in which the film or print is immersed in the test solution, e. g., iodine-azide-starch, are reproducible with respect to volume of reagent and the area treated but do not measure the total residual hypo in the material.

Chemical and electrical conductivity measurements of hypo in the wash water, etc., the spot test methods and the bathing tests may be used, however, for control purposes to indicate the degree of washing if they are first standardized by a testing method which determines the hypo content of the film or print quantitatively, that is, the total residual hypo.

The total residual hypo in films may be determined quantitatively by use of the Crabtree-Ross mercuric chloride test and in prints by a silver nitrate test which involves the conversion of hypo to silver sulfide in situ and estimating the silver sulfide by (a) measurement of the transmission density of the silver sulfide stain, and then reading the corresponding residual hypo content from a standard curve, or (b) matching the silver sulfide stain produced by a drop of silver nitrate with a series of standard stains.

It has been generally recognized since the introduction of sodium thiosulfate (hypo) as a fixing agent that the silver image on negatives and prints was not permanent under certain storage conditions unless the residual hypo and residual silver salts were removed thoroughly by careful fixing and washing.

When these residual salts are present, the negative or print image

* Communication No. 927 from the Kodak Research Laboratories.

** Eastman Kodak Company, Rochester, N. Y.

may either (1) turn yellowish to yellowish brown, or (2) exhibit a metallic sheen. These changes may occur either in the image proper, in the non-image areas, or in both simultaneously. A reaction between the image silver and the sulfur of the residual hypo will change the hue of the image owing to the formation of silver sulfide, while the decomposition of complex silver thiosulfates in the material will produce a yellowish stain in the non-image areas. These changes in the appearance of the negative or print are known as "fading" and are produced more rapidly under storage conditions of high humidity and temperature. Other factors influence the time required to produce these effects such as (1) the quantity of residual hypo and silver salts, (2) the grain size of the image, and (3) the presence of acidic gases in the atmosphere.¹

It has been generally recommended that negatives and prints be well fixed by using two fixing baths to decrease the residual complex silver thiosulfates to a minimum and then well washed to remove the residual hypo. Throughout the photographic literature various tests have been recommended for determining when a negative or print is sufficiently washed with respect to the residual hypo.

Unfortunately most of these tests were used to determine the hypo content of the wash water and when the concentration became very low, depending upon the sensitivity of the test employed, the negative or print was considered washed. However, a few investigators suggested that the residual hypo in the material itself should be determined rather than the concentration in the wash water. Recent studies have shown that when a zero test is obtained in the analysis of wash water there may be a sufficient quantity of residual hypo in the material to produce fading. The quantity of hypo retained is dependent, in part, upon (1) the pH of the fixing bath, (2) the nature of the hardener used in the fixing bath, (3) the combination of fixing baths used, (4) the pH of the wash water,² and (5) the salt content of the wash water.³

CLASSIFICATION OF HYPO TEST METHODS

Two main types of hypo tests have been used, namely, (1) the use of chemical reagents, and (2) the measurement of hypo in wash water samples with electrical devices.

(1) The most commonly used chemicals are potassium permanganate, iodine-starch, iodine-sodium azide-starch, mercuric chloride,

and silver nitrate. Other substances, such as mercurous nitrate, have not been generally accepted. Tests with these compounds have been based on the measurement of the quantity of hypo (1) in the wash water or in the drippings from the film or print, and (2) in the photographic material, including films, plates, and prints.

The tests are usually executed by one of three techniques, namely, (1) dripping, (2) bathing, and (3) spot testing. In the first, the wash water from a definite area of films or prints is drained into a measured volume of the test solution for a given time and, if no color change occurs in the test solution, the material is considered free of hypo. On the other hand, in the second and third techniques, a sample of the material is either bathed in a definite volume of the test solution for a given time or a known volume of the test solution is placed on a definite area of the film or print. However, when silver nitrate is used in bathing and spot tests, it is not necessary to use a definite volume of reagent for a given area of film or print because silver nitrate reacts with hypo to produce silver sulfide *in situ*.

(2) The use of electrical apparatus for indicating the hypo in wash water is dependent upon the fact that hypo dissociates in dilute solution to produce positively and negatively charged ions which, in turn, increase the conductivity of the water.

TESTS FOR HYPO IN WASH WATER

These tests include the estimation of hypo (1) in the wash water, and (2) in the drippings collected from the photographic material.

A sample of wash water is usually withdrawn from the washing tank and is then tested either qualitatively or quantitatively for hypo content. In either case a definite volume of the wash water is tested either by the addition of a few drops of the test solution or by titration with a standard solution, usually iodine with starch indicator. The desired sensitivity of this type of test is obtained by the choice of a suitable concentration of testing reagent.

When the drippings collected from the photographic material are tested, the hypo determined represents neither the hypo content of the wash water nor of the material. The drippings actually contain more hypo than the wash water because of diffusion of hypo solution from within the film or print during the drainage period and, therefore, they contain some of the hypo from within the material. This type of test, however, when made under controlled

conditions, gives a better indication of the residual hypo content of the material than a test made with the wash water. Probably the best known test solution for making the drip test is potassium permanganate which is used as follows:⁴

(a) *Potassium Permanganate Test*

Sodium Thiosulfate (Hypo) Test Solution (Formula Kodak HT-1a)

	<i>Metric</i>	<i>Avoirdupois</i>
Distilled water	180.0 cc	6 oz
Potassium permanganate	0.3 gram	4 grains
Sodium hydroxide (caustic soda)	0.6 gram	8 grains
Water(distilled) to make	250.0 cc	8 oz

To make the test with film take 8 oz (250 cc) of pure water in a clear glass and add $\frac{1}{4}$ dr (1 cc) of the permanganate-caustic soda solution.

Then take a 6- or 8-exposure film, No. 118, No. 616, or equivalent, from the wash water and allow the water from it to drip for 30 sec into the glass of test solution. If a small percentage of hypo is present the violet color will turn orange in *about 30 sec* and, with a larger concentration, the orange color will change to yellow. In either case the film should be returned to the wash water and allowed to remain until further tests produce no change in the violet color.

To make the test with prints take 4 oz (125 cc) of pure water in a clear glass and add $\frac{1}{4}$ dr (1 cc) of the permanganate-caustic soda solution. Pour $\frac{1}{2}$ oz (15 cc) of this diluted solution into a clear 1-oz glass container.

Then take 6 prints, size 4 × 5-in. or equivalent, from the wash water and allow the water from them to drip for 30 sec into the $\frac{1}{2}$ oz of the dilute test solution. If a small quantity of hypo is present, the violet color will turn orange in *about 30 sec* and become colorless in 1 min. In either case the prints should be returned to the wash water and allowed to remain until further tests show that the hypo content has been reduced to a safe margin.

(b) *Iodine-Azide-Starch and Iodine-Starch Tests*

A very useful modification of the well-known iodine-starch test solution was proposed by Jelley and Clark⁵ for testing for the completeness of washing of photographic films. The solution contains iodine, starch, and sodium azide as a catalyst⁶ and was made up as follows:

Two hundred cubic centimeters of water are brought to a boil and a cold-water suspension of 6 grams of soluble starch added. The starch solution is diluted to about 800 cc and cooled to room temperature or below (very important for stability of stock solution) before further additions are made. To this, with stirring, are added 3.25 cc of iodine solution (40 per cent iodine in 40 per cent

potassium iodide) and 13 cc of 10 per cent sodium azide solution. Water is added to make 1 liter.

Different starches vary in their properties with respect to (a) the color produced on reaction with iodine and (b) the stability of the starch-iodine-azide solution. If soluble starch is not used, it may be necessary to boil the starch suspension for 2 or 3 min in order to obtain a satisfactory blue color. Therefore, it is necessary to test a given starch for color reaction with iodine and for stability in the stock solution.

For use, 2 cc of the recommended solution are added to 125 cc of water, and films and prints tested as follows:

For films, the drippings from a 6-exposure $3\frac{1}{4} \times 4\frac{1}{4}$ -in. film, or equivalent area, are allowed to run for 30 sec into 125 cc of the test solution. Decolorizing of the blue solution within 60 sec from the time of the addition of the last drop is taken as an indication that washing is insufficient.

For prints, a drip test can be employed using 15 cc of the diluted test solution. In this case the drippings from each of six 4×5 -in. prints, or equivalent area, are allowed to run for 30 sec into the 15 cc of test solution. If the solution decolorizes within 1 min after the addition of the last drop, the washing is not considered adequate.

In the use of the iodine-starch-azide solution, or iodine-starch, it is necessary that sulfites and alkalis be absent since they also cause decolorization of the diluted solution. Sulfites also cause decolorization of the diluted alkaline permanganate test solution described above.

(c) *Silver Nitrate Test*

The very sensitive silver nitrate test for thiosulfates has been known for a long time. The test involves the reaction of thio-sulfate with silver ion (*e. g.*, silver nitrate) in the presence of excess silver ion to quantitatively produce brown silver sulfide as follows:



The sensitivity to hypo of silver nitrate solution was noted in tests by J. F. W. Herschel⁷ in 1819 and by E. J. Reynolds⁸ in 1863. Lumière and Seyewetz⁹ used the test to determine the hypo in wash water in 1902, while Sedlacek¹⁰ and O. Siebert¹¹ used it to test the hypo in the drippings from films and prints. O. Hackl¹² used the test as an accurate colorimetric method with solutions and emphasized the necessity for the use of acid silver nitrate when considerable sulfite was present.

Silver nitrate is a satisfactory test for thiosulfate in the absence of an excess of neutral sulfites, or other compounds or ions, which react to sufficiently depress the concentration of silver ion. Alkalies in appreciable quantity should also be neutralized since they reduce the concentration of silver ion. Making the silver nitrate solution acid with acetic acid (2 per cent), or sulfuric acid (0.5 per cent), serves to convert neutral sulfites into bisulfites which do not interfere and to neutralize excess alkali.

When using silver nitrate to determine the hypo in the drippings from a film or print, the quantity of hypo may exceed a certain critical value relative to that of the silver nitrate and, as a result, the test is inaccurate. This condition may be avoided in two ways: (1) by employing a sufficiently large quantity of silver nitrate in the solution, or (2) by arranging conditions, such as dilution or quantity of the drippings, *etc.*, so that less hypo is added.

(d) *The Mercuric Chloride Test*

This test solution has not been suggested for the determination of hypo in wash water or in the drippings from prints and films, but could be readily adapted to this purpose. It has the particular advantage of being highly specific for hypo.

In the case of prints, the baryta coating and paper base retain the greater portion of the residual hypo, and it has been shown that the last traces can not be removed by washing¹ except under special conditions such as exist when washing with sea water.³ In the case of the gelatin layers of both films and prints, the quantity of hypo retained is dependent upon several factors including (1) the pH of the fixing bath, (2) the hardener used in the fixing bath, and (3) the degree of exhaustion of the fixing bath.² Thus, when a hypo test of the wash water is negative, it is possible that some hypo may still remain, and this is especially so with prints. For example, when Azo double-weight prints were washed to give a negative test with the potassium permanganate test described above, the prints were found to contain about 0.25 mg per sq in. of hypo as determined by a quantitative silver nitrate test to be described later.

However, there is some advantage in using mercuric chloride instead of potassium permanganate because the mercuric chloride test solution is more sensitive than the permanganate, as seen in Table I of relative sensitivities. The more sensitive the test solu-

tion, the less the quantity of residual hypo in the material but, in general, especially in the case of prints, when the test solution has indicated no hypo in the wash water or drippings there may be a considerable quantity of hypo in the material. Therefore, it is apparent that tests made to determine hypo in the wash water or drippings from films and prints do not indicate quantitatively the residual hypo content of the photographic material.

TABLE I

Relative Sensitivities

Test Solution	Sensitivity
Potassium permanganate.....	1 part hypo per 100,000 parts water
Iodine-azide-starch.....	1 part hypo per 167,000 parts water
Silver nitrate.....	1 part hypo per 1,000,000 parts water
Mercuric chloride.....	1 part hypo per 2,000,000 parts water

On the other hand, this method of testing can be used for control purposes in order to be certain that the films or prints have received the proper degree of washing in a system previously adjusted for washing the material to a definite residual hypo content as determined by a quantitative test method.

TESTS FOR HYPO RETAINED BY PHOTOGRAPHIC MATERIALS

It is obvious thus far that the hypo test should be made on the photographic material in order to determine the total residual hypo of the film or print. This may be accomplished with the commonly used test reagents by bathing, or by spot tests, but it is important that the testing methods be standardized against a quantitative method for the estimation of residual hypo before the test can be said to be "quantitative."

(a) Potassium Permanganate Test

This particular reagent has not been found satisfactory for use as a spot test primarily because the test solution is too weak to permit accurate judgment of color changes. The test solution may also produce a brown stain of manganese dioxide.

It is possible to employ a bathing technique with this reagent, but it is not very practical because (1) a brown stain of manganese dioxide is formed over the film or print area, and (2) only a fraction of the residual hypo in prints is tested.

An example of the bathing technique is the following:

Using a 4 × 5-in. tray, two 2¹/₂ × 4¹/₄-in. prints are immersed side by side in 120 cc of hypo test solution made by adding 1 cc of *HT-1a* stock solution to 119 cc of water, and are agitated continuously. If the test solution does not change color within 2 min, the prints are considered satisfactorily washed.

(b) *Iodine-Azide-Starch and Iodine-Starch Tests*

(1) *Spot Tests*—A spot test on film, using the iodine-starch-azide stock solution in the concentration originally recommended by Jelley and Clark,⁵ has been used by the motion picture industry and more recently by Houck and Sheppard¹³ in experiments on fixing, washing, and drying motion picture positive film. In the latter published work, 0.05 cc of the stock solution was allowed to spread over 1 sq in. of the washed material from which the excess liquid was removed by blotting. The washing was considered complete when the spot failed to decolorize within 1 min. The test when used under these conditions measured between 0.01 and 0.05 mg of hypo per sq in. ($\text{Na}_2\text{S}_2\text{O}_3 \cdot 5\text{H}_2\text{O}$). In order to determine a satisfactory degree of washing of films for commercial purposes a stock solution of twice the concentration of that of Jelley and Clark may be used. One drop of the stock solution is spread over 1 sq in. of the well-drained film, and the film is considered washed if the solution decolorizes in 10 to 15 sec. This test indicates a concentration of about 0.25 mg of hypo per sq in. with negative film.

In 1942 Cary and Wheeler¹⁴ proposed a spot test for the determination of hypo in paper enlargements which involved the use of iodine and starch:

One minim of 400th Normal iodine solution was dropped from an ordinary eye dropper held 6 in. above the print to give a good spread of the drop. Five such drops were placed on each enlargement. If any of the blue spots formed by reaction of the iodine with the starch in the paper showed a tendency to fade within 30 sec, the batch of enlargements was given further washing.

During the study of a similar method of testing in these laboratories it was found that prints tested in this manner with a very weak iodine solution (0.005 to 0.001 Normal) still contained quantities of residual hypo which might cause subsequent fading. The sensitivity of the testing solution was increased considerably by the addition of ¹/₂ to 1 per cent of sodium bicarbonate to a 0.001 Normal iodine solution, but it was necessary to make a fresh solution every two hours by diluting a stock solution of iodine and then adding the bicar-

bonate. Alkalies increase the rate of diffusion of hypo from within the print to the surface during washing and, apparently, have a similar effect in this test. The test was applicable to either wet or dry prints, but a time of reaction of 15 to 60 sec was required for wet prints, while dry prints required as long as 15 min. If starch is added to the iodine, or iodine-bicarbonate solution, the same testing technique may be employed with films provided the film is placed on a white surface such as an enameled tray.

Although the spot test technique is very convenient in practice because of its simplicity and relatively short reaction time (with wet films or prints), only semi-quantitative data can be expected. The test depends upon the diffusion of hypo outward to react with the iodine solution which tends to diffuse inward. In the case of prints the test solution does not diffuse very readily because of the formation of the colloidal starch-iodide complex on and near the surface of the print. Therefore, the iodine-starch reacts only with the hypo that diffuses from within the print in a given reaction time. Obviously, hypo which is selectively absorbed by the paper fibers and the baryta coating probably does not diffuse under these conditions of testing. The addition of bicarbonate, however, has the effect of increasing the quantity of hypo which can diffuse to the surface.

The most important manipulative detail in making a quantitative spot test is to apply a definite volume of test solution over a given area of the print. The reproducibility of this condition is dependent directly upon (1) the size of the drop, (2) the distance the drop falls, and (3) the condition of the film or print with respect to water content. If the material is drained hurriedly as compared with careful squeegeeing, the spread will be greater in the former case because the surface is wetter. Very marked differences were also observed when a short and long interval of time elapsed between the preparation of the surface for testing and the actual test. The control of these three factors was found to vary greatly among a group of experimenters, and the conclusion was reached that the mechanics of the test were not sufficiently reproducible to obtain satisfactory quantitative results.

Since it is likely that a fraction of the residual hypo is not estimated by the spot test, it is necessary to adjust the test to the desired sensitivity by making quantitative determinations of the residual hypo in films or prints by the mercuric chloride and silver nitrate tests subsequently described. For example, if the quantitative

analyses indicate that a print washed under given conditions contained 0.15 mg per sq in. of hypo and this is the desired degree of washing, then the strength of the iodine test solution and the time of reaction should be adjusted to give a negative test with this print. In a similar manner, a series of prints may be washed to contain quantities of hypo which cause the spot test reagent to decolorize over a range of times. After the quantity of residual hypo in the prints is determined, they are plotted on one axis of graph paper and the corresponding decolorizing times on the other axis to obtain a curve from which the hypo content of a print may be determined at different stages of washing from the time required to decolorize the reagent. This curve, however, will be useful only to the operator who developed it because of the large number of variables discussed above. When the spot test has been developed in this manner, the analytical results obtained may be said to be semi-quantitative.

(2) *Bathing Tests.*—Tests may be made with iodine-azide-starch and with iodine-starch in which a film or print sample is immersed in a definite volume of the test solution for a certain time. If the blue starch-iodide has not decolorized, the material is considered washed.

A bathing test may be made as follows:

Place a 4 × 5-in. print or equivalent in the 125 cc of the diluted test solution contained in a 4 × 5-in. tray. The tray is rocked, and if decolorizing occurs within 2 min, the washing is considered incomplete.

Dry prints may be tested by this means, but a much longer time must be allowed for sufficient diffusion. A total time of the order of 5 min in this case is required.

So far as could be ascertained the testing of hypo by placing the prints in the solution had no detrimental effect on their permanency.

This method of testing permits good control of the mechanical operations, such as volume of test solution and area of material. The technique, however, is not very feasible for testing the residual hypo in enlargements.

Since investigation has shown that only a part of the residual hypo is tested in this manner, it is important that the above bathing technique should be standardized by making quantitative analyses as described above and the time of bathing and strength of the test

solution adjusted to measure the desired degree of washing as indicated by the quantitative data.

(c) *Mercuric Chloride Test*

A hypo test solution proposed by Crabtree and Ross¹⁵ in 1930 for the determination of residual hypo in motion picture film is as follows:

Mercuric Chloride-Potassium Bromide Hypo Test Solution

Mercuric chloride.....	25 grams
Potassium bromide.....	25 grams
Water to.....	1 liter

One square inch cut from the wet or dry material to be tested is placed in a small test tube or vial containing 10 cc of the hypo test solution and allowed to stand for 5 min without agitation. The tube is then shaken and the degree of opalescence or turbidity produced in the solution within 5 to 15 min is a measure of the residual hypo. The actual quantity of hypo tested is determined by comparing the opalescence of the solution with a series of standard solutions made by the addition of known quantities of a 1:10,000 sodium thiosulfate ($\text{Na}_2\text{S}_2\text{O}_3 \cdot 5\text{H}_2\text{O}$) solution to 10-cc volumes of the test solution.

This test is dependent upon the formation of a white colloidal precipitate in the presence of an excess of test reagent. Under such conditions where the ratio of mercuric chloride to thiosulfate is greater than 3:2, the white compound produced is $\text{HgCl}_2 \cdot 2\text{HgS}$ ¹⁶ according to the equation

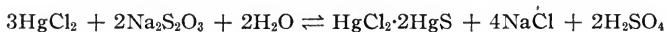

However, the test solution contains potassium bromide so that the colloidal precipitate may be wholly or partially $\text{HgBr}_2 \cdot 2\text{HgS}$.

It has been assumed that all of the hypo reacts with the reagent and diffuses from the film into the test solution. Two confirmatory tests have verified this assumption: (1) when the film was washed to just give a negative test with mercuric chloride, a negative test was obtained with an excess of 1 per cent acidified silver nitrate solution which reacts with all of the hypo *in situ*, and (2) when 1/2 of a film sample was soaked in water to equilibrium and the solution tested with mercuric chloride, an identical value was obtained as by direct determination on the other half of the film sample.

The sensitivity of the test solution is approximately 0.000005 gram or less of crystal hypo ($\text{Na}_2\text{S}_2\text{O}_3 \cdot 5\text{H}_2\text{O}$) per 10 cc of the test

solution or one part in 2,000,000 parts. This is $\frac{1}{10}$ of the quantity stated by Crabtree and Ross, but the lower quantity has been found easily detectable particularly with light of sufficient intensity to obtain the required light scatter when viewing against a black background or with nephelometer-type instruments. The mercuric chloride test for hypo in film is quantitative and has been adopted by the National Bureau of Standards as a standard test for hypo in films intended for archival storage.¹⁷

Two semi-micro adaptations of the Crabtree-Ross test have been published. Gibson and Weber¹⁸ of the National Bureau of Standards test a small punched sample of film in 2 drops of the reagent and Evans¹⁹ of the Department of Agriculture treats $\frac{1}{10}$ of a square inch of film in 1 cc of the reagent. In the latter case the opalescent test solution is picked up by a dropper-type absorption cell and a dial reading of the hypo content obtained directly by means of an apparatus built on the photoelectric principle.

Soon after the recommendation of the mercuric chloride test for the estimation of residual hypo in film, the test was used by the authors for a similar purpose with paper prints. Townsend²⁰ has also described its use for prints.

However, as stated previously, the baryta coating and paper base of prints retain an appreciable quantity of hypo which does not diffuse from the print completely. A comparison of the data obtained in hypo analyses with the mercuric chloride test (a diffusion method) and a quantitative silver nitrate test indicated that the mercuric chloride reagent determined only the readily diffusible hypo. Therefore, while this test is quantitative for film, it is not quantitative for the residual hypo in photographic prints.

(d) *The Silver Nitrate Test*

In 1908 and 1913 Lumière and Seyewetz²¹ treated films, plates, or prints with silver nitrate instead of the wash water or drippings from the material. They placed a drop of silver nitrate solution on the edge of a print, and if there was no brown coloration within 2 or 3 min, the print was considered washed. Lüppo-Cramer²² in 1912 employed the reagent as a spot test for hypo in plates and since 1930 the authors have employed similar methods of testing.

Weyde²³ and Freytag²⁴ have suggested the use of the reagent in the following manner to determine the residual hypo in prints:

The prints were soaked for 1 to 3 min in a 1 per cent solution of silver nitrate, rinsed briefly in water, treated for a short time in a 5 per cent solution of common salt, fixed, and washed again. The density of the brown stain which varies with the quantity of residual hypo was determined by transmitted light.

It was stated that prints washed for 10 min produced a dark brown color with silver nitrate which was equivalent to 0.6 mg of hypo per sq in., and prints washed for 40 min gave a weak yellow color equivalent to 0.06 mg per sq in. It was also stated that silver nitrate produced no visible color in prints below 0.006 mg of hypo per sq in. Unfortunately, Weyde did not describe the method of standardization whereby the above figures were obtained, and consequently it is not known if the method is quantitative.

However, the adoption of a bathing technique and the measurement of the brown stain by transmitted light were the most important improvements toward attaining quantitative estimations of the residual hypo in prints. The silver nitrate test, in contrast to the diffusion methods previously described, is dependent upon the conversion of the residual hypo to silver sulfide *in situ* according to the equation

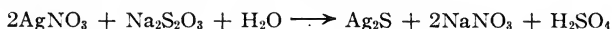

Obviously, if a drop of silver nitrate is placed on either the emulsion side or the base side, the quantity of hypo affected by the reagent is dependent upon the extent of diffusion of the drop which, in turn, depends upon the condition of the print with respect to water content. Therefore, a bathing technique is the most suitable because the reagent enters the print from all sides to react with the residual hypo and deposit silver sulfide *in situ*.

Before a bathing test could be used to give quantitative results it was necessary to standardize the method by placing known quantities of hypo in samples of photographic paper of definite area. This was accomplished by soaking photographic paper samples in dilute solutions of thiosulfate ($\text{Na}_2\text{S}_2\text{O}_3 \cdot 5\text{H}_2\text{O}$) for approximately 5 min.²⁵ The quantity of hypo introduced into the sample was calculated from the volume of solution absorbed which was the difference in weight of the dry sample before soaking and the carefully blotted wet sample after soaking.* The series of samples thus obtained were air dried at room temperature and the hypo converted to silver

* See Reference 25 for further details.

sulfide with acidified silver nitrate as described below. The transmission densities of the sulfide stains were obtained by subtracting the transmission density of the untreated paper from that of the paper plus silver sulfide. These transmission densities were then plotted against the corresponding hypo contents to obtain a standard curve shown in Fig. 1.

A series of single- and double-weight photographic prints was then washed for increasing times and analyzed by Ballard and Hutchins of these laboratories by a method shown to be quantitative for residual hypo in photographic paper.* A 1-sq in. sample of each

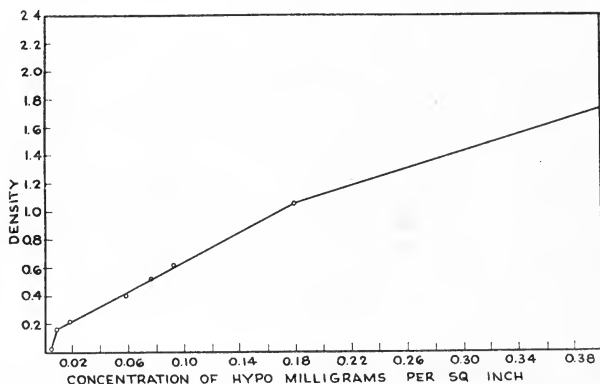

FIG. 1. Standardization curve showing relation between concentration of hypo and transmission density of silver sulfide deposit after treatment of print with silver nitrate.

print was digested for $\frac{1}{2}$ hr at 65°F in approximately 100 cc of acidified thousandth normal silver nitrate solution, an excess of standard potassium iodide added, and then back titrated amperometrically with silver nitrate solution. Corresponding samples were treated with silver nitrate, as described below, to produce silver sulfide *in situ*, the transmission densities obtained, and then plotted against the residual hypo contents. The resultant curve coincided practically with the standard curve in Fig. 1, thereby confirming the semi-quantitative technique used by the authors.

A quantitative estimation of the residual hypo in photographic prints is obtained, therefore, in the following manner. The test solutions required are:

* BALLARD, A., and HUTCHINS, B.: Unpublished results.

Solution A

Silver nitrate.....	10 grams
Sulfuric acid (conc.).....	5 cc
<i>Or</i>	
Acetic acid (glacial).....	20 cc
Water to make.....	1 liter

Solution B

Sodium chloride.....	50 grams
Water to make.....	1 liter

Solution C

Hypo.....	50 grams
Sodium sulfite.....	20 grams
Water to make.....	1 liter

A sample of the non-image area of a print, at least $\frac{1}{4} \times 1$ -in. or an unexposed sheet processed with the batch of prints, is immersed in an excess of Solution *A* for 3 to 5 min, treated in Solution *B* for 3 to 5 min, bathed in Solution *C* for 3 to 5 min, washed, and dried.

The transmission density of the untreated and treated sample is determined by means of a suitable densitometer. A piece of a Wratten blue filter, No. 44, is placed over the eyepiece for these readings which are made most satisfactorily in a dimly lighted room. The difference in the two readings is the transmission density of the silver sulfide produced in the paper and is proportional to the quantity of residual hypo in the print. The equivalent hypo content is then obtained from the standard curve shown in Fig. 1.

The silver nitrate reacts with hypo to produce silver sulfide *in situ*, then the excess silver nitrate is converted to silver chloride which is dissolved by hypo. If an excess of silver nitrate is allowed to remain, exposure to air and light will cause a darkening of the silver sulfide stain, and the resultant transmission density will not be a true measure of the hypo present in the sample.

However, the excess silver nitrate may be blotted from the test print, the print then dried, and the transmission density measured *immediately*. If the silver sulfide stains are kept for further reference, it is then necessary to follow the procedure outlined above.

The quantitative procedure just described can be simplified by adapting it to a spot-testing technique capable of determining residual hypo in prints quantitatively within the range of approximately 0.05 to 0.50 mg per sq in. A series of stains produced by placing a definite volume of 1 per cent silver nitrate on the back of each print in a series of prints having known hypo contents, may be duplicated by water colors or oil paints, and this series of dye stains

then used as the standards for comparison with unknown print samples.

This method of testing the residual hypo in prints has been satisfactorily used for some time by the Paper Testing Department at Kodak Park and could be of value to commercial photographers, photofinishers, amateurs, and archivists in order to assure them of the thoroughness of the washing of their prints. A similar test could also be devised for the measurement of residual hypo in films.

The relative merits of the above-mentioned chemical testing methods are outlined in Table II.

TABLE II
Relative Merits of Chemical Testing Methods

Test	Advantages	Disadvantages
<i>Potassium Permanganate</i>		
(a) Drip Test*	Dynamic—definite color change Not time-consuming	Does not measure residual hypo in material Decolorized by sulfites
(b) Bathing Test		Time-consuming Possible formation of brown stain Color of test solution too weak Does not measure all hypo in material Decolorized by sulfites
(c) Spot Test		Color of test solution too weak Possible formation of brown stain Does not measure all hypo in material Decolorized by sulfites
<i>Iodine-Azide-Starch</i>		
(a) Drip Test*	Color change more definite than with permanganate Not time-consuming More sensitive than permanganate	Does not measure residual hypo in material Decolorized by sulfites and alkalies
(b) Bathing Test**	Test solution strongly colored Volume of reagent and area of material reproducible	Does not measure all hypo in material Decolorized by sulfites and alkalies

Test	Advantages	Disadvantages
	Reagent does not injure image	More time-consuming than drip test or spot test Difficult to apply to very large-size prints and films
(c) Spot Test**	Procedure simple Time required 30 to 45 sec Reagent does not injure the image	Does not measure all hypo in material Decolorized by sulfites and alkali Difficult to place specified volume on definite area and test accuracy depends upon this Time of reaction depends on quantity of water on surface

Iodine

(When mixed with starch, similar to iodine-azide but not as sensitive.)

(a) Drip Test	Same as for iodine-azide-starch	Same as for iodine-azide-starch
(b) Bathing Test	Same as for iodine-azide-starch	Same as for iodine-azide-starch
(c) Spot Test**	Gives blue indicator color with starch in paper base Mixed with sodium bicarbonate (more sensitive in this application than iodine-azide-starch)	Test solution not very stable Does not measure all hypo in material Difficult to place specified volume on definite area and test accuracy depends upon this Time of reaction depends on quantity of water in print

Mercuric Chloride

(a) Drip Test (not recommended)		
(b) Bathing Test*** (using 1 sq in. or less cut or punched from the material)	Reacts with all of hypo in films to give quantitative determination Sulfites do not give test Much more sensitive than permanganate or iodine-azide Produces an opalescence in the solution which can be measured	Not satisfactory for determining total hypo of prints—reacts only with readily diffusible hypo Requires at least 5 min for quantitative development of opalescent indication Requires test piece taken from the material

Test	Advantages	Disadvantages
	Test solution stable Readily adapted to semi-micro determinations	
(c) Spot Test* (not recommended)		
<i>Silver Nitrate</i>		
(a) Drip Test*	Produces brown silver sulfide which can be estimated	Does not measure all of hypo in material Reagent stains operator's hands
(b) Bathing Test***	Reacts quantitatively with hypo in films or prints to produce silver sulfide <i>in situ</i> Does not depend upon volume of test solution, <i>etc.</i> Silver sulfide measured accurately by transmission as density Also quantitative test for tetrathionates	Necessary to use an extra film or print for the test, or a clipping from a negative or print Reagent stains operator's hands
(c) Spot Test**	Reacts to produce brown silver sulfide <i>in situ</i>	Necessary to test clipping, or to test an extra film or print Must be standardized to give accurate measure of residual hypo Reagent stains operator's hands

* These tests give only qualitative indications of the hypo present in the material, but may be adapted to use for controlling the washing process to obtain a given degree of washing.

** These tests give only semi-quantitative measurements of residual hypo in the films or prints, if they are standardized first.

*** These tests give a quantitative determination of hypo in films or prints.

RECOMMENDED TESTS FOR FILMS AND PRINTS

Processed films and prints usually require either archival washing or commercial washing² necessitating the use of appropriate tests to indicate when the desired degree of washing is attained. Archival films and prints should be entirely free of residual hypo while certain quantities can be tolerated in commercial films and prints.²

In view of these demands and the hypo test methods reviewed above, it is considered necessary that quantitative methods of

analysis be used as far as possible. The tests recommended for the determination of the degree of washing for archival and commercial films and prints are indicated in Table III.

TABLE III

Recommended Tests

Processing	Films	Prints
Archival	Mercuric chloride test (page 44)	Standardized silver nitrate test (page 48).
Commercial	Potassium permanganate drip test Kodak <i>HT-1a</i> (page 37); Iodine-azide-starch spot test (page 41); Silver nitrate spot test (page 45)	Spot test adaptation of archival silver nitrate test (page 48)

ELECTRICAL CONDUCTIVITY MEASUREMENTS OF HYPO IN WASH WATER

As has been pointed out in the description of the chemical hypo test methods for the determination of hypo in the wash water, the degree of washing of the photographic material is often incorrectly shown by this analysis. The measurement of hypo in wash water by electrical conductivity methods is also subject to these same limitations and, in addition, is even less specific since any salt or acid present in the water is also indicated.

Despite the fact that determinations of the hypo in wash water do not give an accurate measure of the residual hypo in the films or prints, conductivity measurements can be useful for control purposes in commercial processing. They can indicate for a given processing unit (1) the desired degree of washing, (2) the rate of flow of water through the unit, and (3) the inadvertent addition of hypo during the washing process. Conductivity measurements should only be made on samples of water from thoroughly stirred or agitated wash water.

Sodium thiosulfate (hypo) in common with other chemical salts and acids is dissociated in water into positive and negative ions and therefore increases the electrical conductivity of a given sample of water depending upon the concentration. Hickman and Spencer^{26, 27} made practical use of this property in photography (1) to measure the relative efficiency of washing systems such as trays and tanks, (2) to determine the washing constants of photographic

materials, the best conditions of placement of inlet and outlet, and (3) to study the effects of the rate of flow and the degree of agitation on hypo removal from photographic materials. These investigators employed a Wheatstone bridge system together with a novel arrangement of conductivity cells and a telephone receiver for audibly balancing the electrical circuit. Since the tap water contained salts other than hypo a compensating method^{26, 27} was employed with an identical conductivity cell for the tap water included in the balancing resistance portion of the circuit. Even this method is not independent of the conductivity effect of other salts in the water, and calibration with known quantities of hypo is necessary.

A number of devices have been marketed and claimed to be satisfactory for control in washing prints and negatives. Direct-current indicating types of electrical hypo testing instruments have been described by Bender.²⁸ A similar instrument is marketed as the Haynes Hypo-O-Meter.* These depend upon indication with a d-c milliammeter of current flow from a battery when two electrodes are immersed in water containing a sufficient concentration of an electrolyte (hypo). While their cost is considerably lower than a Wheatstone bridge type of instrument, they are less sensitive for hypo determination and more subject to errors including those resulting from (1) change in supply voltage and (2) polarization and other effects occurring at the electrodes owing to electrolysis.

A more sensitive electrical conductivity type of tester than the usual d-c milliammeter indicating instruments, and which was free from polarization effects, was devised by D. B. McRae of the Eastman Kodak Company. This a-c instrument incorporated a sensitive neon lamp which glowed when the concentration of hypo in the film drippings was in excess of a limiting value (for example, 1 in 80,000 to 100,000 parts, or about the sensitivity indicated by the *HIT-1a* permanganate test as recommended for films). In the use of the instrument the electrode assembly was immersed in a sample of the tap water without hypo (control) and the control arm of a wire-wound high resistance potentiometer turned until the neon lamp glow was just extinguished. Then, upon replacing the control water with the complete drippings from a washing film, a glow was obtained as long as the hypo content was excessive. The instrument, however, varied in sensitivity depending upon the inherent

* Haynes Products Co., 136 Liberty St., New York.

salt content of the water and was therefore not considered suitable for general use.

A compact conductivity instrument for determining dissolved chemicals in wash water has been marketed* which employs a modified Wheatstone bridge circuit and a cathode ray tube "magic eye" for balancing the resistance against that of a single conductivity cell dipped into the wash water. The instrument is calibrated to read grains of sodium chloride per gallon and is provided with a control to compensate for temperature variation.

The usefulness of any commercial apparatus designed to measure the conductivity of the water as a means of indicating the degree of washing is dependent upon (1) the salt content of the water to be used for washing, (2) the concentration of hypo, and (3) the maintenance of unchanging processing conditions, such as the composition of the fixing bath and the source of supply of wash water. If processing conditions are not constant, the conductivity readings are meaningless.

The salt content of the water used for washing limits the concentration of hypo which can be indicated. For example, when the conductivity of the water exceeds the conductivity equivalent of approximately 50 grains of sodium chloride per gal, it is difficult to determine 15 grains or less of hypo per gal (0.25 gram per liter) with a single-scale type of instrument.

When the permissible quantity of residual hypo in the print or film has been selected then, for a given washing system and water supply, it is necessary to determine the scale reading on a particular instrument which indicates that the desired degree of washing has been attained. To accomplish this the following procedure is sufficient: (1) at regular intervals during washing remove a sample of film or print and measure the conductivity of the wash water when each sample is taken; (2) analyze the photographic material for residual hypo; and (3) select the reading corresponding to the tolerable hypo content. A conductivity reading of the wash water before processing indicates the low-scale limit for a given instrument, and the accuracy of the readings near this lower limit is dependent on the sensitivity of the instrument.

* Solu-Bridge Model *RD-4* together with a dip-type conductivity cell *CEL-4* represents a complete unit marketed by Industrial Instruments, Inc., Jersey City, N. J. The conductivity cells are available in various qualities and mountings for dip testing or permanent installation.

CONCLUSIONS

(1) Chemical or electrical conductivity measurements of the hypo content of wash water, or the drippings from washed photographic materials, do not give an accurate indication of the quantity of residual hypo in the photographic material. However, the potassium permanganate test solution (Kodak *HT-1a*) may be used for the commercial processing of film and measures a hypo content of not less than 0.25 mg per sq in. In a previous paper² permissible quantities of residual hypo in film were suggested for commercial and archival degrees of permanence. For example, a maximum hypo content of 0.005 mg per sq in. was suggested for fine-grain films such as Microfile. It is evident, then, that the above permanganate test is not sufficiently sensitive to measure such low quantities of hypo.

(2) Spot tests and bathing tests with iodine-starch and iodine-azide-starch test solutions on the photographic material give semi-quantitative results when the test has been standardized against a quantitative method.

(3) Quantitative estimations of the residual hypo content of film are obtained with the Crabtree-Ross mercuric chloride test solution. Only the readily diffusible hypo content of prints is measured with this reagent, and it is therefore not recommended for use with paper.

(4) Quantitative determinations of the residual hypo content of prints are obtained by (a) bathing the prints in excess silver nitrate solution, (b) determination of the transmission density of the resulting deposit of silver sulfide, and (c) reading the corresponding hypo content from a standard curve. A simplified spot test adaptation may be employed in commercial work involving the comparison of the stain on the print tested with a series of standard stains.

REFERENCES

¹ CRABTREE, J. I., EATON, G. T., AND MUEHLER, L. E.: "The Elimination of Hypo from Photographic Images," *J. Phot. Soc. Amer.*, **VI** (1940), p. 6; *J. Soc. Mot. Pic. Eng.* **XXV** (Nov., 1940), p. 484.

² CRABTREE, J. I., EATON, G. T., AND MUEHLER, L. E.: "The Removal of Hypo and Silver Salts from Photographic Materials as Affected by the Composition of the Processing Solutions," *J. Soc. Mot. Pic. Eng.*, **XLI** (July, 1943), p. 9.

³ CRABTREE, J. I., AND EATON, G. T.: "Washing Photographic Films and Prints in Sea Water," *J. Soc. Mot. Pic. Eng.*, **XL** (June, 1943), p. 380.

⁴ "Elementary Photographic Chemistry," Eastman Kodak Company, Rochester, N. Y. (1941), p. 120.

⁵ JELLEY, E. E., AND CLARK, W.: "A Test for Thiosulfates," *Brit. J. Phot.*, **89** (1929), p. 714.

⁶ FEIGL, F.: "Über einen neuen empfindlichen Nachweis von Sulfiden und Thiosulfaten (Concerning a New Sensitive Test for Sulfides and Thiosulfates)." *Z. Anal. Chem.* **74**, p. 369 (1928); for earlier observations see Raschig, F.: Schwefel und Stickstoffstudien (Sulfur and Nitrogen Studies) **201** 1924, also *Ber. deutsch. chem. Ges.*, **48**:(1915), p. 2088.

⁷ HERSCHEL, J. F. W.: *Edinburgh Phil. J.*, **1** (1819), p. 26.

⁸ REYNOLDS, E. J.: "On the Detection of Hyposulfite of Soda," *Brit. J. Phot.*, **10** (1863), p. 360.

⁹ LUMIÈRE, A., AND L., AND SEYEWETZ, A.: *Bul. Soc. Franc. Phot.* (1902), p. 251.

¹⁰ SEDLACZEK, A.: "Ueber den Nachweis von Natriumthiosulfat (On the Detection of Sodium Thiosulfate)," *Das Atelier des Photographen*, **10**, No. 2 (1903), p. 25.

¹¹ SIEBERT, VON OTTO: "Wann haben unsere Platten und Bilder genügend gewässert? (When Are Plates and Prints Sufficiently Washed?)," *Das Atelier des Photographen*, **4** (1903), p. 62. (Refers to work of Gaedicke.) *Cf. Photo Woch.*, Feb. 13, 1900.

¹² HACKL, O.: "Colorimetrische Bestimmung von Spuren Thiosulfat auch neben Sulfit (Colorimetric Estimation of Traces of Thiosulfate in the Presence of Sulfit)," *Chem. Zeit.*, **47** (1923), p. 266.

¹³ HOUCK, R. C., AND SHEPPARD, S. E.: "The Influence of pH on Washing Films after Processing," *J. Soc. Mot. Pic. Eng.*, **XXXI** (July, 1938), p. 67.

¹⁴ CARY, E., AND WHEELER, A. H.: "Quantitative Tests for Residual Hypo," *Amer. Phot.*, **36** (Jan., 1942), p. 16.

¹⁵ CRABTREE, J. I., AND ROSS, J. F.: "A Method of Testing for the Presence of Sodium Thiosulfate in Motion Picture Films," *J. Soc. Mot. Pic. Eng.*, **XIV** (Apr., 1930), p. 419.

¹⁶ ALLEN, E. T., AND CRENSHAW, J. L.: "Crystalline Forms and Genetic Conditions of the Sulfides of Zinc, Cadmium, and Mercury," *Amer. J. Sci.*, **34** (1912), p. 341.

¹⁷ "Evaluation of Motion Picture Film for Permanent Records," U. S. Department of Commerce, National Bureau of Standards, Miscellaneous Publication No. **N 158**, 5, 1937.

¹⁸ GIBSON, J. E., AND WEBER, C. G.: "The Evaluation of Motion Picture Films by Semi-micro Testing," *J. Soc. Mot. Pic. Eng.*, **XXXII** (Jan., 1939), p. 105.

¹⁹ EVANS, G. H.: "Testing Aerial Photographic Negatives for Residual Sodium Thiosulfate," *Photogrammetric Eng.*, **VIII** (1942), p. 121.

²⁰ TOWNSEND, L. G.: "Proposed Residual Hypo Determinations on Film and Paper," *J. Documentary Reproduction*, **I**, No. 4 (1938), p. 366.

²¹ LUMIÈRE, A. AND L., AND SEYEWETZ, A.: "Tests for Hypo in Prints after Washing," *Brit. J. Phot.*, **55** (1908), p. 417; *Ibid.*, **60** (1913), p. 873.

²² LÜPPO-CRAMER: "Adsorptionsverbindungen der Gelatine mit sauren Agenzien (Adsorption Compounds of Gelatin with Acid Agents)," *Phot. Ind.*, **10** (1912), p. 1006.

LÜPPO-CRAMER: "Zum auswaschen der Fixier-Lösungen (On the Washing Out of Fixing Solutions)," *Phot. Ind.*, **15** (1917), p. 686.

²³ WEYDE, E.: "On the Possibility of Increasing the Stability of Photographic Prints," *Brit. J. Phot.*, **82** (1935), p. 376.

²⁴ FREYTAG, H.: "Was für die Haltbarkeit unserer Bilder Wichtig ist? (What Is Important for the Permanence of Prints?)," *Phot. Chronik*, **44** (1937), p. 401. (This appears to be a repetition of the work of Weyde.)

²⁵ CRABTREE, J. I., EATON, G. T., AND MUEHLER, L. E.: "The Quantitative Determination of Hypo in Photographic Prints with Silver Nitrate," *J. Frank. Inst.*, **235**, No. 4 (1943), p. 351.

²⁶ HICKMAN, K. C. D.: "The Washing of Photographic Products—Part II, An Electrical Device for Measuring Minute Amounts of Hypo," *Phot. J.*, **63**, NS 47 (1923), p. 208.

²⁷ HICKMAN, K. C. D., AND SPENCER, D. A.: "The Washing of Photographic Products," *Phot. J.*, **64**, NS 48 (1924), p. 539; *Ibid.*, **65** NS 49 (1925), p. 443.

²⁸ BENDER, L. L.: "Electrical Testing for Hypo Elimination," *The Camera*, **55** (1937), p. 364.

CHARACTER OF WAVES PRODUCED BY EXPLOSIONS*

E. W. KELLOGG**

Summary.—In view of the widespread interest in explosions and their effects, a non-mathematical discussion is offered attempting to explain in a qualitative way some of the characteristics of waves resulting from explosions. No new data are offered, but several references are given. A number of peculiarities of high-pressure waves may be deduced from the simple and well-known fact that the higher the compression, the greater is the velocity of propagation, plus the theorem developed by Rayleigh and others, that close to a source which is small compared to wave length, the air constitutes an inertia load rather than a pure resistance.

Within the last year the various effects of explosions have taken on an extraordinary degree of importance and interest, and persons concerned with sound engineering are, of course, especially interested in the peculiarities of the waves set up by explosions. Nearly everyone has at least read that the high-pressure wave travels faster than ordinary sound. It has also been reported many times that the failure of windows and walls is frequently outward as if the principal effect was a wave of low pressure rather than one of high pressure. Without attempting to give any exact analysis of the effects of explosions, this paper is intended to answer a few of the questions which naturally arise in the minds of persons interested in sound, but who have not had occasion or opportunity to study this aspect of it.

Early authorities on sound, for example, Lord Rayleigh¹ and Horace Lamb,² have pointed out that when the variations of pressure become appreciable fractions of atmospheric pressure, sound waves do not maintain a constant wave shape, but the higher the pressure, the faster is the rate of propagation, and this causes the waves to change in shape. For example, in Lamb's "Dynamical Theory of Sound," p. 180, the conclusion of a mathematical analysis is stated as follows:

"The parts of the wave where the density is greater therefore gain continually on those where it is less. Thus if the relation between s and x be exhibited graphically, the curve A in the annexed figure takes after a time some such form as B .

* Presented May 5, 1943, at the Technical Conference in New York.

** RCA Victor Division of Radio Corporation of America, Indianapolis, Ind.

The wave becomes, so to speak, continually steeper in front, and slopes more gradually in the rear, until a time arrives at which the gradient at some point becomes infinite."

There are two ways of explaining this variation of velocity with pressure. The first, and perhaps the simplest way of looking at it, pictures the higher frequency components of pressure waves as being propagated very much as they would be normally, but at the same time being carried forward on the general forward movement which occurs in the pressure region of the lower frequency or longer wave components. In other words, the lower frequency pressure wave produces a wind in the direction in which it travels, and this wind car-

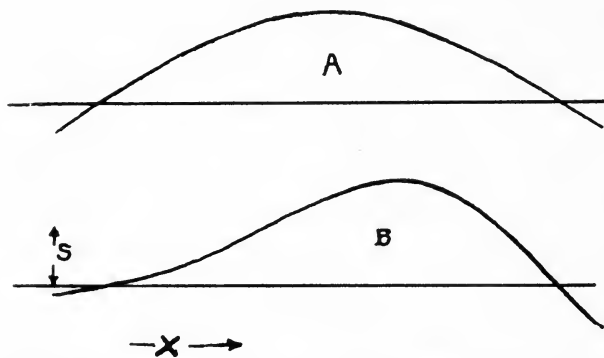

FIG. 1. Fig. 62 of "Dynamical Theory of Sound" by Horace Lamb. x = distance; s = condensation (or compression).

ries the higher frequency components forward at an increased velocity. Another way of looking at the subject is to remember that although the velocity of sound is independent of pressure (at any given temperature), the compression that occurs during the passage of a wave raises the temperature, and the velocity of propagation varies approximately as the square root of the absolute temperature. If air at 68°F is suddenly compressed to two-thirds of its initial volume, the temperature rises by about 92°F . Quick compression to one-half the initial volume would raise the temperature by 165°F , and to one-fifth the volume would raise the temperature to about 600°F . Thus, in the region of excess pressure, the temperature is high and the velocity of propagation high. As shown in Fig. 1, if we start with an approximately sinusoidal pressure wave, the crest or region of maximum pressure tends to move forward with respect to the regions of

lesser pressure, and the wave goes through a sequence of changing shapes with the front growing continually steeper and the lower pressure portion of the wave trailing farther behind.

It is pointed out in the *Encyclopedia Britannica* article on "Sound,"³ that this steepening wave front is analogous to the formation of "breakers" over shelving beaches. Here the rate of propagation is greatest at the crest of the wave, and this moves forward with respect to the rest of the wave until the front becomes unstable and breaks. The formation of this very steep wave front has engaged the interest of physicists for a long time.

Many measurements have been made of the velocity of propagation, showing that this may range all of the way from the speed of ordinary sound (about 340 meters per second at 60°F) at considerable distances, to as high as 5000 meters per second close to the explosion. It is estimated that the time required for the pressure to rise from atmospheric to the maximum may be as short as 10^{-11} second, but no available measuring equipment is capable of measuring such time intervals. Neither is it possible to determine directly the maximum pressures and temperatures, but some indication of these may be inferred from the velocity of propagation. In an *Acoustical Society* paper,⁴ L. Thompson and N. Riffolt report experimental results of a large number of tests at the Naval Proving Grounds, Dahlgren, Virginia, and they develop a formula which satisfies the observed values of velocity very closely. In the paper just mentioned, and in two other papers by Dr. Thompson,^{5, 6} many interesting points are brought out, and thermodynamic problems are discussed. Reasons are given for the belief that the rise of temperature under conditions of such extreme rapidity as occurs in an explosion wave front would be much greater than that calculated by the usual formula for adiabatic compression, on which the illustrative values of temperature rise, given in the paragraph above, are based.*

If the air in the wave front is in a transient condition, having the effect of low specific heat, but from which it reverts to normal specific heat in a time of the order of microseconds, it follows that the extreme maximum of pressure would last for a very brief interval, but this

* The formula applicable to cases of ordinary speed of compression is $P_2/P_1 = (V_1/V_2)^{1.4}$. A modified adiabatic law and an exponent of 1.66 are considered in these references to be more nearly correct for compressions taking place in such short times that the modes of vibration of the molecules do not reach an equilibrium.

does not mean that the pressure would fall quickly to zero. It would drop to the value corresponding to ordinary "adiabatic" compression, and then fall at a rate dependent upon the character of the explosion and distance the wave has traveled.

In order to give some idea of the way the shock wave shoots ahead

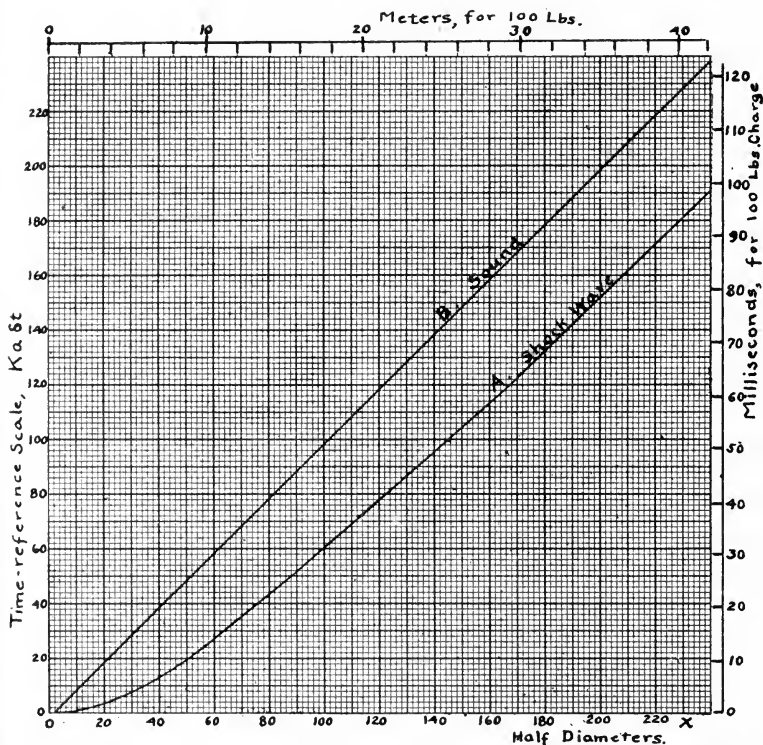

FIG. 2. Propagation of shock wave. Calculated by formula of Thompson and Riffolt.

of the position a wave front would occupy, if propagated at the speed of ordinary sound, a specific case has been calculated using the Thompson-Riffolt formula. Curve A of Fig. 2 shows the relation between distance and time for the case of an explosion of 100 lbs of TNT. Distance is measured in meters from the surface of the original charge, and time is shown in milliseconds. For comparison, curve B is drawn which shows the distance *versus* time relation for ordinary sound. It will be seen that the shock wave runs ahead of the position

for ordinary sound, very rapidly at first, and then it continues to gain, but more slowly. At 0.05 second after the explosion, the shock wave is about 7.5 meters (25 ft) ahead of the normal sound wave, or reading the difference between the two curves vertically, the shock wave reaches a point 20 meters away, about 20 milliseconds sooner than would an ordinary sound wave.

The initial conditions produced by an explosion obviously depend on the rapidity with which the explosive is converted to gas. Messrs. Thompson and Riffolt state* that in the case of high explosives (those of high detonating velocity which are set off by a shock wave within the material and not by burning or temperature), the shock wave starts away from the original surface of the charge with a velocity which is approximately the same as the speed of propagation of the wave of detonation in the explosive. This is a characteristic of the explosive; hence the initial velocities depend primarily on the explosive material and not on the size of the charge. Large charges move greater masses of gas through greater distances, but not with higher initial velocities or pressures. They find that if the distances are expressed in units equal to the radius of the original charge (assuming this to be spherical or applying a small correction if it is not spherical), a single curve will serve to show what takes place as a result of explosions or charges covering a wide range of sizes.

In Fig. 2 the lower and left-hand scales are in terms of units employed by Messrs. Thompson and Riffolt. The symbol X represents the distance in half diameters of the charge, and the ordinate, instead of being stated in units of time, is expressed in units proportional to time. The quantity K is proportional to the reciprocal of the diameter of the charge; a is the normal velocity of sound (so that Ka is the velocity of ordinary sound, expressed in half diameters of the charge, per second, instead of in meters per second) and δt is the elapsed time. This makes the ordinate $Ka\delta t$ equal to the number of half diameters which ordinary sound would travel in the time interval δt . Curve B , which has been drawn in for comparison, is a straight line having a slope of 45° . If one charge is of twice the diameter of another, the maximum pressures and initial velocities at the surfaces of the original charges do not differ greatly, but the wave from the large charge will travel twice as far before it has fallen in pressure and slowed down by the same ratio as that of the smaller charge.

* They also give reference to other investigations.

Stating the relation in a different way, the ultimate distance by which the shock wave runs ahead of ordinary sound is directly proportional to the dimensions of the charge. Thus, with a 12.5-lb. charge TNT, the shock wave at a large distance would be about 4.4 meters or 1.3 milliseconds ahead of ordinary sound, as compared with 8.8 meters and 2.6 milliseconds in the case of a 100-lb charge having twice the diameter of the 12.5-lb. charge.

The following figures, taken from a table in one of Dr. Thompson's papers,⁵ show the velocity at successive distances from the source:

Shock Waves Calculated for $k = 1.66$

Distance, $X-1$	0	2	8	11	17	22	30	39	50	85	130	>200
Velocity ratio, V/a ..	20.0	10.0	5.0	4.0	3.0	2.5	2.0	1.7	1.5	1.2	1.1	1

Photographic tests with charges of TNT and TNB have shown that the velocities with which the hot gases shoot out are from two-thirds to three-fourths the initial velocity of the shock wave.

For a discussion of molecular actions at the instant of pressure rise, the reader may refer to pp. 250-253 of the same paper.⁵ There are many phases of the problem of the actions of explosions which are outside the scope of the present paper, but simple acoustic theory with the assumption that where the pressure is high the velocity of propagation is also high is sufficient to predict at least the condition of a very steep wave front. The same proposition also would predict that the farther the wave travels, the longer it stretches out, the low-pressure region at the rear lagging farther and farther behind. If the disturbance which produces the wave results in a period of sub-atmospheric pressure following the excess pressure, this part of the wave will travel even more slowly than ordinary sound, and the result will be a trough which lags farther and farther behind the pressure wave. Such periods of low pressure are usual and hence this period of negative pressures is an important part of explosion waves.

It may not be at once evident why an explosion should produce a vacuum. When a diaphragm, whose diameter is large compared with the wavelength in air, is vibrating with all parts of the surface in phase, the air against which it pushes constitutes a practically pure resistance. The air does not try to keep on moving forward when the diaphragm stops pushing it. On the other hand, when waves are expanding from a source which is small in relation to the wave length, the air acts like an inertia load, with only a certain fraction of its impedance in the form of true resistance.⁷ Since the pressure applied

at the center to move the air radially outward is largely utilized for accelerating the air, rather than overcoming a resistance, the air tends to keep on moving outward after the pressures in front and behind are equalized. In other words, it overshoots, leaving a partial vacuum behind. The vacuum then tries to suck it back with the result that there is a damped oscillation.

A good many years ago, the writer, while theorizing about sound, made the statement that an explosion in free space had no characteristic pitch. This statement was immediately challenged by a non-technical person who asserted very positively that small explosions produced high-pitched sounds and larger explosions produced low-pitched sounds. This appeared at the time to be possibly a psychological effect, but better acquaintance with the nature of expanding sound waves made it evident that an explosion in free space can produce not simply a pulse or single, positive wave front, but a train of waves with alternating pressures. If a large body of gas is released, longer time is required to push the air outward until the pressure at the center reaches atmospheric or below. This greater time means longer wavelength and the condition that the wavelength is large compared with the size of the source can hold when there is a large explosion as well as when there is a small one. Thus, we would expect that in the case of a large explosion the oscillations would be slower, but the decrement (or number of waves in the oscillation) would not differ greatly from the case of a small explosion.

Although it may be said in general that explosions, particularly when the explosive itself is in concentrated form (and not spread out as might be the case when a weak mixture of gas and air explodes), have a tendency to be oscillatory, there is another explanation of the presence of a negative wave following the positive. In the absence of standing waves, or in other words when the wave motion is entirely outward, the entire region of excess pressure is also a region of forward particle velocity. If there were no negative waves, there would result a permanent transfer of air outward from the source. Such bodily and permanent outward movement might appear to be justified by the evolution of a large amount of gas at the source, but we find that at greater distances, this gas is only "a drop in the bucket" compared with the total outward movement which a purely positive wave would produce.

We are all familiar with the inverse square law which states that in outwardly expanding waves, the energy carried by a unit area of wave

front falls off as the inverse square of the distance from the source, or in other words at a rate which practically compensates for the increased area of the wave front (the total energy remaining practically constant). But the energy in a wave varies as the square of the amplitude, so that when the energy (per unit of wave front area) falls to one-fourth of the previous value, the amplitude will have fallen only to one-half. If the amplitude falls 50 per cent while the wave front area is increasing fourfold (twice the distance means a sphere of 4 times the surface), the product of amplitude by area will have doubled. Thus, the farther the wave expands the greater is the total volume of air which moves across a given spherical surface.* We might perhaps, at a point 10 ft from the source, in view of the newly formed gas, have a wave of positive pressure only, but 100 ft away the expanding wave (if it continued to be a pure positive wave) would cause a movement of nearly 10 times as large a volume of air, and there would only be 10 per cent enough volume of the newly formed gas to justify a permanent outward movement of this magnitude. Actually, the positive wave does progress very much as described and produces this large outward motion of air, but a trailing negative wave develops which draws the surplus air back. It is obvious that at large distances, there is a negligible net outward movement, and the only possible type of wave, or train of waves which can meet the requirements, is one in which the product of time and velocity in the forward and backward directions becomes equal. This is somewhat analogous to the transmission of electrical impulses through transformers. You may apply a unidirectional pulse to the primary of a transformer, but on the secondary you invariably get a wave having equal positive and negative areas.

Reverting to the subject of windows bursting outward, the first question which arises is whether this is not similar to the theory that carrying an umbrella insures sunshine. The outward bursting is a paradox, and therefore much is made of an observed example. However, the writer has been informed that by actual counts there is a

* This relationship explains how a horn helps the radiation from a loud speaker diaphragm. Just as a transformer is desirable to couple a high-impedance source of electrical power to a low-impedance load, the diaphragm can best drive a small quantity of air against a high back pressure or resistance, while the outside air presents very low-resistance to movement, and the best coupling is effected by a transformer (horn) whose input is small volume at high pressure and whose output is large volume at low pressure.

predominance of outward bursting. A surface exposed to the wave will be subjected to two substantially equal and opposite impulses (the product of pressure and time being the same for the positive as for the negative wave), first in one direction, then in the other. The impulses, however, are very different, the positive pressure being more like a sharp blow, and the negative like a prolonged push in the opposite direction. The interval is likely to be such that the push will be properly timed to catch the wall structure on the rebound from the initial inward push, in which case it would be expected to throw the pieces outward. In cases where the explosion produces an actual train of waves, much would depend on the natural frequency of the structure, most of the failures being in cases where the frequency of the wave-train is close to that of the wall. In such cases the wall would reach its maximum amplitude and stresses after several waves had acted upon it. The direction of the apparent break might then have almost equal probabilities for the two directions.

The question naturally arises whether the steep wave front, established during the period of high pressure, is maintained indefinitely after the waves have reached low pressures. The factor which operates at high pressure also operates at low pressure, though in much less degree, and therefore there is a continuous tendency to maintain the steep wave front. However, there is undoubtedly an excess energy absorption present at this surface of sudden change, which would have the effect of reducing its sharpness. If we should attempt to represent a very steep wave front by means of a series of sine waves, we should find that it comprises many high-frequency components, and it is well known that these are attenuated in air more rapidly than those of lower frequency. When we come to distances great enough to involve curvature of the earth's surface, it is to be expected that the steep wave front will travel in straight lines, except as it may be refracted by wind or temperature differences. It will thus tend to shoot off at a tangent, while the lower frequency components of the sound continually spread downward and maintain their contact with the surface of the earth.

The writer wishes to thank Dr. Thompson for information and suggestions.

REFERENCES

- ¹ RAYLEIGH, LORD: "Theory of Sound," II, pp. 30-41, *McMillan & Co* (London), 1940.

² LAMB, H.: "Dynamical Theory of Sound," p. 177, *Edward Arnold Co.* (London), 1925.

³ *Encyclopedia Britannica*, 1941 Edition, **XXI**, p. 22.

⁴ THOMPSON, L., AND RIFFOLT, N.: "The Propagation of Shock Waves in Air" I, *J. Acous. Soc. Amer.*, **11**, No. 2 (Oct., 1939).

⁵ THOMPSON, L.: "The Propagation of Shock Waves in Air" II, *J. Acous. Soc. Amer.*, **11**, No. 2 (Oct., 1939).

⁶ THOMPSON, L.: "Shock Waves in Air and Characteristics of Instruments for Their Measurement," *J. Acous. Soc. Amer.*, **12**, No. 1 (July, 1940).

⁷ RAYLEIGH, LORD: "Theory of Sound," **II**, p. 112, *McMillan & Co.* (London) 1940.

FIFTY-FIFTH SEMI-ANNUAL TECHNICAL CONFERENCE

OF THE

SOCIETY OF MOTION PICTURE ENGINEERS

HOTEL PENNSYLVANIA, NEW YORK, N. Y.

APRIL 17-19, 1944

Officers in Charge

HERBERT GRIFFIN, *President*
EMERY HUSE, *Past-President*
L. L. RYDER, *Executive Vice-President*
W. C. KUNZMANN, *Convention Vice-President*
D. E. HYNDMAN, *Engineering Vice-President*
A. C. DOWNES, *Editorial Vice-President*
A. S. DICKINSON, *Financial Vice-President*
E. A. WILLIFORD, *Secretary*
M. R. BOYER, *Treasurer*

Directory of Committee Chairmen

Atlantic Coast Section	C. R. KEITH, <i>Chairman</i>
Papers Committee	W. H. OFFENHAUSER, JR., <i>Chairman</i> C. R. DAILY, <i>Vice-Chairman, West Coast</i>
Publicity Committee	JULIUS HABER, <i>Chairman, assisted by</i> HAROLD DESFOR
Membership and Subscription Committee	JAMES FRANK, JR., <i>Chairman</i>
Registration and Information	W. C. KUNZMANN
Reception and Local Arrangements	D. E. HYNDMAN
Luncheon and Dinner Dance	BARTON KREUZER
Hotel and Transportation	O. F. NEU
Projection Committee	H. F. HEIDEGGER, <i>Chairman, assisted by</i> Members New York Projectionists Local No. 306
Ladies Reception Hostess	MRS. E. I. SPONABLE

Note: In order to comply with the wartime paper conservation program only names of the committee chairmen serving our conferences will be listed in released bulletins for the duration.

TENTATIVE PROGRAM

Monday, April 17, 1944

- 9:00 a.m. *Hotel, 18th Floor: Registration.*
10:00 a.m. *Salle Moderne: Convening the Conference with a General Session and committee reports.*
12:30 p.m. *Hotel Roof Garden: SMPE Get-Together Luncheon for members, their families and guests.*
2:00 p.m. *Salle Moderne: Afternoon Session.*
8:00 p.m. *Salle Moderne: Evening Session.*

Tuesday, April 18, 1944

- 9:00 a.m. *Hotel, 18th Floor: Registration.*
10:00 a.m. *Salle Moderne: Morning Session.*
2:00 p.m. *Salle Moderne: Afternoon Session.*
8:00 p.m. *Georgian Room: Informal Dinner Dance.*

Wednesday, April 19, 1944

Open morning.

- 1:30 p.m. *Hotel, 18th Floor: Registration.*
2:00 p.m. *Salle Moderne: Afternoon Session.*
8:00 p.m. *Salle Moderne: Evening Session and Adjournment.*

PAPERS

Members and others who desire to present technical papers before this Conference should communicate immediately with the Chairman or Vice-Chairman of the Papers Committee, whose names and addresses are given on the inside front cover of this issue. Papers presented are later published in the JOURNAL. *Do not delay* sending the committee the title of your paper and the name of the author.

RESERVATIONS

When you receive the hotel room reservation cards in March please return them immediately. No rooms will be available or guaranteed *unless booked in advance of the Conference dates.*

W. C. KUNZMANN
Convention Vice-President

MEMBERS OF THE SOCIETY
LOST IN THE SERVICE OF
THEIR COUNTRY

FRANKLIN C. GILBERT

ISRAEL H. TILLES

*Order Your Copy Now!**

THE TECHNIQUE OF MOTION PICTURE PRODUCTION

Covering current technical practices in motion picture production, presented as a Symposium at the 51st Semi-Annual Technical Conference of the SMPE in Hollywood, 1942. . . . Now published in book form.

160 Pages—41 Illustrations

Each section written by a specialist in the motion picture industry. . . Authentic information on various technical problems of motion picture production.

CONTENTS

I	Technology in the Art of Producing Motion Pictures.....	Leon S. Becker
II	Cinematography in the Hollywood Studios:	
	Black and White Cinematography.....	John W. Boyle
	Putting Clouds into Exterior Scenes.....	Charles G. Clarke
	Technicolor Cinematography.....	Winton Hoch
III	Special Photographic Effects.....	Fred M. Sersen
IV	Re-Recording Sound Motion Pictures.....	L. T. Goldsmith
V	The Technique of Production Sound Recording..	Homer G. Tasker
VI	Prescoring and Scoring.....	Bernard B. Brown
VII	Illumination in Motion Picture Production.....	R. G. Linderman, C. W. Handley and A. Rodgers
VIII	The Paramount Transparency Process Projection Equipment.....	Farciot Edouart
IX	Motion Picture Laboratory Practices.....	James R. Wilkinson
X	The Cutting and Editing of Motion Pictures...	Frederick Y. Smith
XI	The Projection of Motion Pictures.....	Herbert A. Starke

THE TECHNIQUE OF MOTION PICTURE PRODUCTION is a useful and valuable reference for technicians, students, librarians, and others desiring technological data on the motion picture industry compiled in one volume.

Price \$3.50†

Published for the Society of Motion Picture Engineers by Interscience Publishers, Inc.,
215 Fourth Avenue, New York 3, N. Y.

* 20% discount to members in good standing if ordered through SMPE.

† Ready about March 31st. Orders must be accompanied by check or money order. Use form on other side.

The Society of Motion Picture Engineers

Its Aims and Accomplishments

The Society was founded in 1916, its purpose, as expressed in its Constitution, being the "advancement in the theory and practice of motion picture engineering and the allied arts and sciences, the standardization of the mechanisms and practices employed therein, and the maintenance of a high professional standing among its members."

The membership of the Society is composed of the technical experts in the various research laboratories and other engineering branches of the industry, executives in the manufacturing, producing, and exhibiting branches, studio and laboratory technicians, cinematographers, projectionists, and others interested in motion picture engineering.

The Society holds two conferences a year, spring and fall, at various places and generally lasting four days. At these meetings papers dealing with all phases of the industry—theoretical, technical, and practical—are presented and discussed, and equipment and methods are often demonstrated. A wide range of subjects is covered, many of the authors being the highest authorities in their particular lines of endeavor. On occasion, special developments, such as the SMPE Visual and Sound Test-Films designed for the general improvement of the motion picture art, are placed at the disposal of the membership and the industry.

Papers presented at conferences, together with contributed articles, translations, and reprints, and other material of interest to the motion picture engineer are published monthly in the JOURNAL of the Society. The publications of the Society constitute the most complete existing technical library of the motion picture industry.

Order Form for The Technique of Motion Picture Production

Society of Motion Picture Engineers
Hotel Pennsylvania
New York 1, N. Y.

Date

Gentlemen:

Please send me THE TECHNIQUE OF MOTION PICTURE PRODUCTION.
Enclosed is check or money order for

Name: No. Copies

Address:

Member (\$2.80 per copy).*

Non-Member (\$3.50 per copy).*

* Add 1% Sales Tax if mailed to New York City address.

JOURNAL OF THE SOCIETY OF MOTION PICTURE ENGINEERS

Vol 42

FEBRUARY, 1944

No. 2

CONTENTS

	PAGE
The Work of the Training Film Branch, Photographic Division, Bureau of Aeronautics, U. S. Navy—An Overview O. GOLDNER	71
Production Planning for Navy Training Films R. B. LEWIS	78
Making Films That Teach R. BELL	85
The Training Film Program in Action—A Case History H. E. CARR, E. NELL, JR., AND T. SARGENT	93
Like This P. MURPHY	100
Cinematography Goes to War W. R. MCGEE	102
The Motion Picture Program of the Industrial Incentive Division, U. S. Navy C. H. WOODWARD	113
The Secondary or Psychological Phase of Training Films E. NORTH	117
Fifty-Fifth Semi-Annual Technical Conference of the Society	123

(The Society is not responsible for statements of authors.)

JOURNAL OF THE SOCIETY OF MOTION PICTURE ENGINEERS

HARRY SMITH, JR., EDITOR
ARTHUR C. DOWNES, *Chairman*

Board of Editors

JOHN I. CRABTREE ALFRED N. GOLDSMITH EDWARD W. KELLOGG
CLYDE R. KEITH ALAN M. GUNDELFINGER CHARLES W. HANDLEY

ARTHUR C. HARDY

Officers of the Society

- *President:* HERBERT GRIFFIN,
133 E. Santa Anita Ave., Burbank, Calif.
- *Past-President:* EMERY HUSE,
6706 Santa Monica Blvd., Hollywood, Calif.
- *Executive Vice-President:* LOREN L. RYDER,
5451 Marathon St., Hollywood, Calif.
- **Engineering Vice-President:* DONALD E. HYNDMAN,
350 Madison Ave., New York, N. Y.
- *Editorial Vice-President:* ARTHUR C. DOWNES,
Box 6087, Cleveland, Ohio.
- **Financial Vice-President:* ARTHUR S. DICKINSON,
28 W. 44th St., New York, N. Y.
- *Convention Vice-President:* WILLIAM C. KUNZMANN,
Box 6087, Cleveland, Ohio.
- *Secretary:* E. ALLAN WILLIFORD,
30 E. 42d St., New York, N. Y.
- *Treasurer:* M. R. BOYER
350 Fifth Ave., New York, N. Y.

Governors

- **FRANK E. CARLSON**, Nela Park, Cleveland, Ohio.
- *†CHARLES W. HANDLEY**, 1960 W. 84th St., Los Angeles, Calif.
- **EDWARD M. HONAN**, 6601 Romaine St., Hollywood, Calif.
- *†CLYDE R. KEITH**, 195 Broadway, New York, N. Y.
- **JOHN A. MAURER**, 117 E. 24th St., New York, N. Y.
- *HOLLIS W. MOYSE**, 6656 Santa Monica Blvd., Hollywood, Calif.
- *WILLIAM A. MUELLER**, 4000 W. Olive Ave., Burbank, Calif.
- *H. W. REMERSHIED**, 716 N. La Brea St., Hollywood, Calif.
- **EARL I. SPONABLE**, 360 W. 54th St., New York, N. Y.
- *JOSEPH H. SPRAY**, 1277 E. 14th St., Brooklyn, N. Y.
- *REEVE O. STROCK**, 195 Broadway, New York, N. Y.
- **WALLACE V. WOLFE**, 1016 N. Sycamore St., Hollywood, Calif.

*Term expires December 31, 1944.

**Term expires December 31, 1945.

†Chairman, Pacific Coast Section.

‡Chairman, Atlantic Coast Section.

Subscription to non-members, \$8.00 per annum; to members, \$5.00 per annum, included in their annual membership dues; single copies, \$1.00. A discount on subscription or single copies of 15 per cent is allowed to accredited agencies. Order from the Society of Motion Picture Engineers, Inc., Hotel Pennsylvania, New York 1, N. Y.

Published monthly at Easton, Pa., by the Society of Motion Picture Engineers, Inc.
Publication Office, 20th & Northampton Sts., Easton, Pa.

General and Editorial Office, Hotel Pennsylvania, New York 1, N. Y.

Entered as second-class matter January 15, 1930, at the Post Office at Easton, Pa., under the Act of March 3, 1879. Copyrighted, 1944, by the Society of Motion Picture Engineers, Inc.

JOURNAL OF THE SOCIETY OF MOTION PICTURE ENGINEERS

Vol 42

FEBRUARY, 1944

No. 2

THE WORK OF THE TRAINING FILM BRANCH, PHOTOGRAPHIC DIVISION, BUREAU OF AERONAUTICS, U. S. NAVY—AN OVERVIEW*

ORVILLE GOLDNER**

Summary.—The Training Film Branch of the Navy is responsible for the procurement, production, and distribution of training films for all activities of the Navy.

The Branch (then Unit) was established, and carries on its work, according to conditions set down in a directive issued by the Secretary of the Navy on October 31, 1941. Since its establishment, the Branch has supervised the production of approximately 2000 titles covering every aspect of Naval training.

The organization of the Training Film Branch has grown from a small operational unit to a sizable activity made up of 5 sections; i. e., Procurement, Cataloguing, Distribution, Project Supervision, and Education.† At the present time, over 1100 training film titles, including both slide films and motion pictures, are in production. Two hundred persons, half of whom are officers, work for the Training Film Branch. The facilities of 50 commercial producers throughout the United States are being used in addition to the Navy's own production facilities at the Photographic Science Laboratory, Naval Air Station, Anacostia, D. C.

First of all, it must be clearly stated that although the Training Film Branch is located in the Bureau of Aeronautics of the Navy, its activities are not limited to training film problems of that Bureau. In fact, at the present time only a relatively small proportion of the work of the Training Film Branch is on the subject of aeronautical training. The reasons for establishing training film responsibilities in the Photographic Division of the Bureau of Aeronautics in the fall of 1941 are few and simple. The outstanding reason given is that, as originally conceived, the making of training films was largely a photographic problem. Where else should photographic responsibilities be

* Presented Oct. 21, 1943, at the Technical Conference in Hollywood.

** Lieutenant, USNR, Head of Training Film Branch, Photographic Division, Bureau of Aeronautics, Washington, D. C.

† Since the date on which this paper was presented certain modifications in the organization of the Training Film Branch have been made.

placed, if not in the division and bureau having the most experience in photography? Perhaps it is oversimplifying to say that the precise location of the training film organization within the Navy, or the interpretation given to its function, is of little real importance as long as the job of procurement, production, and distribution of training films is being done effectively to meet the needs of the total Naval Establishment. *This* subject, of course, could be highly controversial—and frequently is, but regardless of the decisions reached, certain facts are significant.

In the past year, the personnel of the Training Film Branch has more than trebled. Today, about 200 persons—civilians, enlisted men, and officers—are doing the work in the 5 sections of the Branch. Under the Branch administration office, these sections are Project Supervision, Education, Procurement, Cataloguing, and Distribution. The largest section is that of Project Supervision, which is responsible for the initiation and follow-through of all training film production. The exact procedures of this section will be explained in the papers that follow.

Working closely with the Project Supervision Section is the Education Section. Together, these 2 sections do the research, preplanning, and aligning of production with the training job to be accomplished. Obviously, there must be ever-present in the minds of those concerned the sharply defined objectives to be met by every training film production. And every detail that is reducible to explanation and clarification on paper in words, in photographs, or drawings, must be so handled to insure that all those involved in production understand and hew to the line. Work of this kind requires the closest coöperation and coördination between Project Supervision and Education personnel and the technical advisers assigned by the agencies requesting training film production. How this is done in its many diverse aspects, and about the never-ending problems, you will also learn from the papers that follow.

As has been stated, the Project Supervision and Education Sections are concerned largely with production. How much is produced and what is implied? Consider for a moment these statistics: between September 15, 1942, and September 15, 1943, a total of 297 Navy training motion pictures, averaging 2 reels each, were produced. Besides using the facilities of commercial, industrial, and Hollywood producers, the effective top-notch facilities of the Navy's Photographic Science Laboratory were used for highly specialized secret

and confidential productions. During the same period, 1139 slide films were produced.

What about the subject matter? It could not be less intricate than the latest battleship, or plane, or amphibious barge, or the deadliest torpedo, or bomb, or naval gun. Nor could the subject matter be less complicated than the tactics involved in using these weapons of technological warfare. And Navy training film production not only covers what *is*, but what *is going to be*—in other words, things you may know about and things yet to be revealed. Evermore frequently, the Training Film Branch is called upon to parallel training film production with new weapons and new plans.

It must be said in honesty that all production is not of the type to which the foregoing emphasis has been given. There are always the training films for "Boot" training—films for orientation to, and indoctrination in the simple, traditional, yet necessary life and procedures of the U. S. Navy. A typical example of this type of film is a series of 32 short motion pictures on *Navy Ratings*. They are being made to give the new recruit a complete, accurate and interesting panorama of all the jobs in the Navy which are available to him. For the first time in Naval history the young man or young woman who arrives at the designated Naval Training Station, full of trepidation, will get *pictorial* guidance to assist him in choosing his Navy vocation. He will know what to expect if he decides to become a Torpedoman, or a Boatswain's Mate, or a Parachute Rigger. She, the enlisted Wave, will see what will come of her choice as a Storekeeper, or an Aviation Machinist's Mate.

To get the footage for this fascinating series of motion pictures, Training Film Branch personnel supervised photography in the cramped quarters of submarines, in blimps, in the booming turrets of big guns aboard warships, and in dozens of other locations in and on the sea, on land, and in the air. In fact, personnel at work on research and production for the Navy's training films have covered half the earth, including such remote locations as New Caledonia in the South Pacific and Kiska in the North.

Now, research, writing good scripts, actual photography in the places and under the conditions indicated, and all the other work that goes into getting a story-telling photographic image on film for training purposes, are difficult enough in wartime. But there are a myriad of time-consuming, and often frustrating, related details with which the production of every Navy training film must be interlocked, and by

which it must be controlled. Imagine for a moment, if you can, the number of agencies concerned and the volume of correspondence necessary to guarantee as far as is humanly possible that every civilian working for every producer of every training film is a loyal United States citizen; and further, that every inch of film, and every sheet of paper, and every still photo and drawing, which relates to the training film, is guarded and kept safe against sabotage or the possibility of falling into enemy hands. This is a security job of the greatest importance.

Along this line, imagine how many official letters have to be written with rigid limitations to clear the way for a civilian camera crew to go aboard a Navy Yard, an Air Station, an Ordnance Factory, or a submarine, patrol plane, or transport. It is redundant to say that the Navy's producers, scattered over the country, get most impatient because they can not get immediate clearance by return wire or over the telephone for Joe Doaks, the newly hired cameraman, to join a photographic crew on an amphibious maneuver or other secure activity. Frequently producers blandly request the availability of aircraft, ships, guns, and everything else, for this or that important (to them) shot, believing, apparently, that the war can be called off for given periods while we make training films. Nothing could be further from the truth, for, in fact, the training film program must be superimposed on and geared to every activity preparing for combat without disturbing its rhythm more than the minimum. Material, equipment, and personnel must be used, when available, in the larger training or operational pattern set for them, and not at our discretion for training film production.

Planning and cooperating with the Project Supervision and Education Sections on production are the special Training Film Branch officers who are responsible for handling all the implied security details and the minutiae of arrangement making.

To this point, we have been concerned for the most part with the *production* functions of the Training Film Branch. The emphasis has been so placed because of your interests as technicians and engineers in the motion picture industry. But of no lesser importance are the functions carried on by the Procurement, Distribution, and Cataloguing Sections of the Branch.

As of this date, the Training Film Branch has approximately 1100 titles in one stage or another of production. To arrange for the procurement of this number of training film titles, to write the contracts

originally, and to make the never-ending adjustments in contracts created by unforeseeable conditions is a big job. To prepare estimates of film needs and budgets for periods as far ahead as 1945 is also a big job. This is the type of work done by the Procurement Section of the Branch. These are the routine functions. At the same time, production and distribution costs must be studied and analyzed continuously to guarantee, on the one hand, the maximum flexibility of operation within budgets and, on the other hand, that the Navy gets its money's worth.

The work of the Distribution Section is that of distributing the Navy's training films to training establishments in the United States, to ships at sea, and to Navy activities in the near and far corners of the world. Of genuine significance is the constantly increasing number of training films being distributed every month. A year ago in September, 9430 prints of all types were distributed. During September of this year, 42,518 training films were shipped. With statistics like these, indicating such increased training film utilization, the place and importance of training films in the war effort can hardly be questioned, nor can their importance in post-war education be doubted.

It is necessary here to point out that the Navy, like the other Armed Services, does not distribute its own films only. At all times, the Training Film Branch, through its Cataloguing Section, is searching every known source for training films *produced* or in *production* which may be useful in the Navy's training program. Over 7000 training film titles from all sources are listed. This is but one function of the Cataloguing Section.

The largest job of the Cataloguing Section is that of keeping the production records of the Branch up to date, and to issue at regular intervals a comprehensive catalogue containing all film titles known to be of value for Navy training. The current catalogue of 174 pages contains 1200 titles cross-indexed in several ways to achieve maximum usefulness. Titles are classified in 48 lists starting with those on the subject of *Abandoning Ship* and ending with those on *Welding and Soldering*. In the Cataloguing Section, a group of specialists views and evaluates every training film produced by the Navy and all others considered useful which have been produced by other Armed Services, other countries, and civilian and industrial organizations. New requests for training films by Naval activities are checked carefully against all available lists to insure that there will be no duplication,

no waste of time, effort, and strategic material. It is important to point out that the U. S. Armed Services have established a close liaison on training film problems and procedures to prevent duplication and to raise standards of production, improve distribution, and achieve more effective utilization.

This statement leads to a summary of this paper in which an attempt has been made to give an overview of the work of the Training Film Branch and its relation to the growing and many-faceted United States Naval Establishment and its activities throughout the world. Moreover, in addition to the intra-Navy aspect, there are indicated two other aspects which can not be overlooked. There is the Branch work which is inter-U. S. Armed Service; that part of the job which relates to, and is carried on in coöperation with, the training film work of the other U. S. Armed Services. Lastly, but of increasing importance, there is the Branch job which relates to the training film work and needs of the Armed Services of the United Nations. In explanation of what is being done to accomplish this, here are a few details.

To implement the exchange of training film information and training films between the Armed Services of the United Nations, there was established in July, 1942, the United Nations Central Training Film Committee. The function of the Committee, quoted in part from the *Constitution & Terms of Reference*, is as follows:

“To provide opportunity for the discussion of problems, points, or questions relating to the production, procurement, and distribution of training films; providing such problems, points, or questions relate to the interchange of training films among the member nations represented on the Committee;

“To provide for the facilitation of procurement and distribution of training films among the Branches represented, when such films are the concern of more than one member Branch;

“To collect and collate such experience in the use of training films as would prove of assistance in advising members of the ways in which the best results have been achieved.”

The Committee holds regular meetings at The National Archives in Washington. In the year ending July 1, 1943, over 3½ million ft of motion pictures for training were received and filed; 5500 film strips were handled in the same period. A large number of the motion pictures received were screened, and reported in written reviews; in fact, 1247 screenings were held.

The subject matter of the films covered the vast range of war equipment and tactics, and war problems of every type—obvious and

obscure. Of special interest were the subjects translated into Chinese, Spanish, and Portuguese, furnished by the U. S. War Department.

Besides the subjects supplied to the United Nations Central Training Film Committee by the Armed Services of the United States, there were hundreds of subjects supplied by the British Commonwealth. Over 300 subjects came from the British Army and the RAF. On the basis of plans being made by the United Nations Central Training Film Committee, the coming year promises to be one of expansion, with more United Nations becoming active participants in the Committee and with closer relationships being established. The possibilities of this coöperative effort for the exchange of training film information and training films are left to your imagination.

To a degree, the three aspects of the Training Film Branch job—*intra-Navy, inter-U. S. Armed Services, and inter-United Nations*—are closely aligned. However, to a larger degree, each aspect involves special problems in planning, procurement, and distribution which must be met with unique, yet convergent methods. The total job must be done with one objective in mind at all times. In spite of the complexities of the job and the pressures of this or that group with singular enthusiasms, one purpose must be foremost: the planning, production, and distribution of training films and all the rest of the related work carried on by the Armed Services are, *at this time*, for the purpose of training personnel in the ways of warfare to bring about victory with a minimum of losses in the shortest time possible.

In this statement of purpose, the use of the words "at this time" may provoke some question. It should not, because it is generally admitted that winning the war is not enough. Winning and keeping the peace may be a far larger task. Certainly, the techniques which are training men so effectively in the methods of destruction and war can be used to train them in the methods of construction and peace. This fact is recognized in some quarters, and enlightened individuals within the Armed Services are making plans for the use of training films in adjusting military personnel to peace-time living. This is a job of training, retraining, and conditioning. This is the training film job for that unpredictable period between total war and total peace—that period, the conditions and length of which can not yet be determined. But that is a subject beyond the scope of this paper—a subject for another time.

PRODUCTION PLANNING FOR NAVY TRAINING FILMS*

RICHARD B. LEWIS**

Summary.—Navy training film production procedures have been developed through nearly 2 years of production experience in the special problems of making films for the Navy. Procedures are designed to permit full use of commercial, industrial, and Navy film production facilities, and, at the same time, to insure full Navy control of film content, presentation, and security.

The production of a successful Navy training film requires close coöperation among the Navy activities requesting films, the Training Film Branch, and the film producer. Coördination of effort is established and maintained by means of a schedule of production which provides all contributors with a series of definite checking points. As each check point is reached, all persons concerned review progress and approve or disapprove plans for subsequent action. The established procedure for production reduces the time and cost of production, clarifies thinking in terms of the training purpose of the film, and assigns specific responsibility for each stage of film development. Only when these aims are accomplished can a training film meet the Navy standard of excellence.

The Navy has had nearly 2 years of concentrated production experience in making training films. During this period, production procedure has been evolved and standardized. Production procedure for Navy training films has been determined, first, by the nature and purpose of training films, second, by the nature of the Navy and its special training problems and, third, by the process through which any film is manufactured and brought to the screen.

First, above all, the purpose of a training film is different from the purpose of an entertainment film: the objective of a training film is not to show an imagined event in the most dramatic way possible, but the objective is to show the most *effective* way to do some specific job, whether it be checking a plane before flight, or taking a beach-head under fire. Or the objective may be to teach a principle or a concept that will be remembered, even in the heat of battle.

Thousands of new men have had to learn the ways of the Navy

* Presented Oct. 21, 1943, at the Technical Conference in Hollywood.

** Lieutenant, USNR, Senior Project Officer, Training Film Branch, Bureau of Aeronautics, Washington, D. C.

—how to become fighting men; how to use new tools, new weapons; and how to live under unfamiliar and trying living conditions. The men with previous Navy experience have had to learn how to use the new and complex devices of warfare that are created at an astonishing rate, and, at the same time, they have had to train the new men.

Three major types of training have offered three separate problems in producing training films. First, there is training in understanding and operating devices. A typical series of films of this nature might be *The Mark "Z" Torpedo*—how it operates; how to keep it ready for firing; the stabilizing mechanism, its disassembly, repair, and assembly; and so on. Within the *Mark "Z"* there may be 20 to 40 special units requiring attention of skilled machinists, and a film may be needed to describe each part, to show how to make it ready to do its job. The *Mark "Z"* is one subject—add to it how to operate a boiler room; how to get a ship under way; how to use signaling devices; how to use navigation instruments; how to use the torpedo director *Mark 3*; and dozens of others; and you have subjects for a multitude of training films on how to get a ship to a place where the *Mark "Z,"* ready for action, can be sent streaking toward the tender spot of the enemy. Films on these subjects, generally designed to develop skills, are usually of the how-it-works or how-to-work-it variety, planned for the special schools of the Navy and for use in the fleet to supplement the practical experience gained by the men in action.

The second large training problem is related to the tactics of Naval warfare. In this field, typical subjects are: *The Activity of the Shore Party in Amphibious Warfare*, *Fighter Combat Tactics*, and *Tactical Uses of Radio*. Films on tactics offer especially complicated production problems. The doctrines of tactics develop and change rapidly during modern warfare; photography must be sandwiched into an already full program of special training and organizational activities; and combat personnel and equipment can be spared only for a limited time.

The third and last problem for which Navy training films are made is that of "indoctrination" or "orientation." Films give the future seaman or airman a picture of what is ahead of him, how he is expected to behave when he meets the enemy, and what he can do to prepare himself for the battle to come. To take some examples: there is *Tomorrow We Fly*, a story to tell a boy in preflight school

how he is to be made into a flier, just as his plane, according to plan, is being made ready for him to fly. In another, *Proceed and Report*, the new pilot is shown how to make that difficult transition from life at a training station to the new and different world aboard his first ship.

Navy training films have included three-dimensional photography, photography through bomb sights and through gun sights, photography under the surface of the sea, all types of aerial photography, and photography involving many other special problems which challenge the technical ability of Navy and commercial film production personnel. Animation, model photography, stop motion, process photography, and color photography have all contributed major problems, sometimes exciting, sometimes discouraging, but always interesting.

The production of a successful Navy training film requires close coöperation among the representatives of the Navy activity requesting the films, the representatives of the Training Film Branch of the Bureau of Aeronautics, and the personnel of the commercial or Navy film unit assigned to make the film. Coördination of effort is established and maintained by a standardized production procedure which includes a series of definite checking points. As each check point is reached, all persons concerned review progress and approve or disapprove plans for subsequent action.

The mechanics of this procedure will sound familiar to you—they are inherent in all film production, but, throughout all planning for Navy training films, there are the following special considerations:

- (1) The film must teach.
- (2) The film must teach technical information or concepts for which no previous film presentation may have been devised.
- (3) There must be a production plan that fits Navy production conditions.
- (4) The technical experts will often differ in their viewpoints, yet the picture must show the right way or a right way to do a job, with which they all concur.
- (5) The widely divergent viewpoints on what to teach, and how to film what is to be taught, must be resolved rapidly and accurately.
- (6) The film must be made as quickly as possible, as inexpensively as possible, and must be technically correct.

The first step in production procedure within the Training Film Branch is the appointment of the Project Supervisor, who will steer the training film through production from start to finish. The Project Supervisor stands in relation to a training film in production

much as does the producer in the entertainment film field. The Project Supervisor knows film production procedure and techniques; he knows Navy training film production problems and procedures for meeting those problems; and the Project Supervisor knows, above all, how to coördinate the efforts of many persons and activities to one predetermined end—an effective training film.

Another appointment, made at the same time, is that of the Education Officer, a specialist in the use of training films and training techniques. He serves at two important stages of production: during preplanning and before the final editing.

A Technical Adviser is selected by the requesting agency as the best qualified expert in the subject field of the film. On some productions several technical advisers may serve, each bringing some special contribution to insure complete accuracy of the final production.

Although the original request for a training film gives a more or less specific indication of its purpose and content, a careful definition must be made of the production job ahead. With the original request before them, the Project Supervisor, the Education Officer, and the Technical Adviser begin the first step in production planning—the Preliminary Outline for each film to be produced.

The first stage of the Preliminary Outline is the initial research. This includes a statement of what is to be taught, an analysis of the audience for whom the film is intended, and an indication of why the subject was chosen for presentation in a training film. Next in the initial research, the operations to be pictured and the principles to be pictured are listed, followed by the nomenclature to be taught.

Note the use of the terms “operations to be *pictured*” and “principles to be *pictured*”! Here, early in the production planning, is the first effort to stress the fact that a visual presentation is in preparation.

The initial research usually involves the study of manuals and reports, trips to training schools, ships, and sometimes to factories, before all the relevant facts that will go into the completed film are defined and written down.

With the information in the initial research complete, the Project Supervisor and the Education Officer develop the second step in the Preliminary Outline—the production analysis.

At this time, the Project Supervisor and the Education Officer,

as specialists in the field of training films, must answer a series of questions:

Is the picture to be a motion picture or a film strip, sound or silent, color or black and white? Should original production be on 16- or 35-mm film? What should the final footage run? And what techniques are required—live action, model photography, stop motion, direct sound? If slide films are to be made, shall they be art work, or photography, or both? What are the special pictorial possibilities of the film? What are the production difficulties to be anticipated?

Other highly important questions are then answered:

What teaching techniques are to be used? Are review sequences essential? How much time should be devoted to each of the operations and principles to be pictured? The style of the film, the use of humor, music, titles, and other problems are analyzed and presented.

The production locations are listed, and the materials and personnel necessary in the picture analyzed; and an estimated production schedule is outlined.

When the material in the initial research and the production analysis is combined into one report, the Preliminary Outline is complete. An approval of the Outline is obtained from the requesting authority, the Technical Adviser, and the Training Film Branch administration. The result? A clearly defined and approved plan for a training film, for a specific audience, to do a specific job, and the production requirements are clearly indicated. This is the first check point.

When the Preliminary Outline is approved, the producer for the film is selected. The selection of a producer is determined by a number of factors:

- (1) the information in the Preliminary Outline;
- (2) the geographical location of the producing organization;
- (3) the previous production experience of the producer;
- (4) available facilities and special abilities;
- (5) the cost proposal submitted.

With the Preliminary Outline approved and the producer selected, the next step in production is the preparation of an Action Outline. This Action Outline is written by the writer assigned to the project under the supervision of the Project Supervisor and the Technical Adviser. This Outline is a list of shots and effects in sequence indicating the structure and format of the film. At this point additional research is usually necessary, with the Preliminary Out-

line used as a guide. Whenever possible, the Action Outline is accompanied by simple sketches or still photographs to visualize the word description.

The purpose of the Action Outline, with accompanying sketches or photographs, is to further develop and emphasize the visual presentation of the film. Each written statement indicating photographic treatment is complete but concise, and only suggestions for the commentary are included. For indoctrination or orientation films with a "story" approach, a Treatment Synopsis may be substituted for the Action Outline.

When in final form, the Action Outline or Treatment Synopsis is approved by all persons working on the project—the second check point—and the writer is authorized to write the Master Script.

The Master Script is the complete and final script for the training film, and is the guide for production. It includes: complete story-board sketches, camera directions in detail, directions for editing, and commentary or dialog. When all approvals are obtained on the Master Script—the third check point—the training film is ready for studio or location production.

During the preparation of the Master Script, the Project Supervisor and the Technical Adviser have been preparing the way for production. Arrangements are made for technical equipment and Navy personnel needed in the production; requests for permission to work aboard ships or shore establishments are made well in advance; special arrangements must be made in advance for every move of production crews into and about establishments; producers personnel is checked for eligibility to work on Navy film production; and production schedules are made.

The next check point is really a long, continuous check during production of the film. The Technical Adviser checks during photography for accuracy of content in the film. "Dailies" are checked by the Project Supervisor and the Technical Adviser for photographic quality, accuracy of content, and adherence to the Master Script. Deviations from the script that seem necessary during production are carefully evaluated and, if justified, are approved and officially authorized.

When photography is complete, the next check point is a screening of the work-print of the film cut in sequence. Or, in the case of a slide film, the frame cards are reviewed. At this point, the commentary is read from the Master Script by a competent narrator.

Any changes in the commentary or in the pictorial material are proposed and justified at this time. Timing and effects are discussed and agreed upon. The Technical Adviser, the Project Supervisor, the Education Officer, and the representative of the producer attend this check screening and, again, approvals are recorded.

It may seem that numerous approvals are necessary, and they are. The making of a training film is not a one-man show. Making an accurate, effective, and interesting training film is a painstaking and brain-bumping job for a lot of people. So, there are still 2 more checks.

Check 6 is a screening of the edited film, with titles, but usually without opticals or effects, accompanied by the sound-track run in interlock. Slide films are shown in a test print, or the final frame cards are viewed, with the sound on record. This is the final screening for checking technical accuracy, and for Navy standards of sound recording, editing, and over-all teaching effectiveness. If each check has been thorough before this screening, no changes should be required. However, minor changes may still be necessary, and if so, are authorized.

The last check, then, is the acceptance screening, the "World Première" for a Navy training film. Representatives of the requesting authority, the Technical Adviser, the Project Supervisor, the Education Officer, and the members of the Training Film Branch Administration staff are present to see the finished picture. The final signatures of approval of the film are recorded, and the film is ready for release.

This established production procedure clarifies thinking in terms of the training purpose of the film; it assigns responsibility for each stage of film development; and it reduces the time and cost of production by eliminating false starts and retraced steps. In addition, because of the enthusiastic and patriotic coöperation given by the many producing organizations, it has been the means of preparing Navy training films in steadily increasing numbers with steadily increasing standards of excellence.

MAKING FILMS THAT TEACH*

REGINALD BELL**

Summary.—The Training Film Branch is responsible for giving Navy instructors photographic training aids that will help them instruct clearly, accurately, expeditiously, and well. Making such training aids is both a science and an art. As a science it requires fundamental psychological and educational knowledge as well as the photographic "know how." It demands analysis of the subject matter to be taught, the situation in which it is to be taught, the men who are to learn, and the ways in which they can be taught. As an art it requires a synthesis of photographic techniques, expertness with words, teaching skills, and showmanship.

Out of analysis of the training situation comes definition of the film's specific purpose; determination of the idea and vocabulary level of the film; decision as to the teachable and usable unit breakdown of the film subject; and choice of the film medium and of photographic and script approach and method. From then on, during all phases of production, the staffs' responsibility is to see that narration, photography, animation, and effects all contribute to fulfilling the teaching purpose of the film.

It has been made perfectly clear in the preceding papers that the Training Film Branch is charged with the responsibility for giving Navy instructors training aids that will help them instruct clearly, accurately, expeditiously, and well.

Planning such films is not an entirely uncomplicated matter, for it demands the harmonious marriage of teaching with cinematography. No shotgun wedding will suffice either. Unless there is genuine union of the teacher and the producer, a bastard film will result—dull, jerky, laborious if lacking the cinematographer's art; superficial, dramatic, educationally purposeless if lacking the teacher's guidance. We of the Navy know, because we have had both types.

It is interesting to review the mistakes of some of our early film makers.

The first that comes to mind was a "Newsreeler," a man who rushed into photography with little or no planning. Making a training film was easy to him: get long shots and a few medium shots of a man or

* Presented Oct. 21, 1943, at the Technical Conference in Hollywood.

** Lieutenant, USNR, Head of Education Section, Training Film Branch, Photographic Division, Bureau of Aeronautics, Washington, D. C.

group of men in action on the subject of the film. Cut the film to tell a story, preferably a rapid story. Grind in some music and sound effects—loud music and loud sound effects. Then write your commentary, and get a guy with plenty of punch to narrate it!

One early 1942 film hastily organized on that basis may be chosen as an example. It was a film on an operation in handling explosives that required infinite pains on the part of the ordnance technician, and slow, painstaking, carefully timed movements on his part. If the operation was not done precisely, if the technician did *not* wait just so long between movements, it was a 99 to 1 shot that the demolition on which he was working would explode and he would be splattered over the landscape. At one point he was supposed to wait a full second between quarter turns of a wrench, which was an intolerable delay to the newsreel photographer-director. So, since the technician was working on a dummy explosive anyway, and varying his procedure to get continuity of movement would give the kind of photography the news-director wanted, the technician was given orders to unscrew the fuse rapidly!

Probably the news-photographer-director never did understand the explosion on the part of the technical advisers and the Training Film Branch education officers when the interlocked was shown! The fact that men viewing the film in training for their infinitely dangerous tasks would inevitably identify themselves with the photographed technician and proceed as he did rather than as the commentator said they should, was a completely new idea to him. And their questions as to what *really* was going on at various points in the film embarrassed him considerably, and went a long way toward convincing him that the newsreel emphasis on medium and long shots was not enough for a training film.

He was an intelligent man. So he chalked up the footage shot to profit and loss, sat down with the technical adviser and the Training Film education officer and project supervisor, analyzed the operation in detail, planned a new film, shot it under conditions that were technically and educationally acceptable, and produced a useful training film—long weeks after the originally planned delivery date.

The second objectionable producer chosen for comment is the "Ambitious Slide Filmer." He's the man who thinks that his long experience in slide film production makes him an ideal motion picture director. Training Film Branch officers still shudder over an atrocity made for the Navy 18 months ago, before our own consultative staff

was built up. It purportedly told the story of a factory's production line. So far as anyone could tell from looking at the finished film, a still photographer was given a motion picture camera. The director picked out the scenes he wanted photographed. The cameraman planted his camera at the spot, lighted it, and kept grinding until he had what he and the director thought was enough footage. He didn't move up on it; he didn't move away. He just shot the scene. Then he quit, moved his gear to the next place indicated, photographed it, and moved on as before.

Your imaginations can picture what went on in the cutting room when this static material came in. And what the script writer assigned to the production said when he realized that the burden of continuity, action, and interest was placed on his shoulders. The result was a series of still pictures optically tied together for motion picture projection, and with a sound-track instead of a disk recording of the narration. The best that could be said of it was that it just wasn't good.

The third trouble maker for us in those early days—and he's still with us as a matter of fact—is the "Stereopticon Lecturer" turned director. He does not really care much what goes on the screen so long as the spoken words are meticulously accurate. He has implicit faith that the commentary will tell the story, detail the process, and give the training desired. If photography is even remotely connected with the narration, he is satisfied. He is the director who takes a technical subject and develops it as a classroom lecture. He opens up on the lecturer, a long-haired actor arrayed as a Lieutenant Commander, then cuts to the rapt faces of a cadet audience hanging on the instructor's words. He interjects an unreadable page of a book, fades to a blackboard with hieroglyphics on it, then wipes back to the actor-officer, cuts to the audience, still mysteriously alert (which the film's audience no longer is), and so on through 45 min of highly technical and complicated lecture-narration. Now and again the audience is jerked awake by the inclusion of some guns firing, as the officer-narrator mentions sea-fighting, or a hard-bitten Chief brings some gear (and a guttural sync-sound observation) to the lecture rostrum for a quick demonstration of some gadget. But mostly the class is expected to listen, and to be enthralled by close-ups, medium shots, or long shots of the audience and the instructor.

The best that can be said of this kind of film—frequently asked for initially by a word-minded technical adviser—is that it is an excellent

soporific; the worst, that it utterly fails of its teaching purpose, and prostitutes the motion picture medium.

The fourth trouble maker is the "Insufferable Bore." He isn't necessarily the director. He may be the writer, or the Navy technical director. But he dominates the production to which he is assigned. He gets to know so much about the subject through his long experience with it, or through his new research on it, that he loses his perspective. Every detail must go fully on the screen. If a screw is to be screwed in, *every* turn must be visually recorded. If a plane is rolled out of the hangar, the camera must show its whole progress; dolly out as far as possible, relocate and dolly again. If certain seamanship rules are to be explained, they must be explained in stupifying minutiae.

One example out of several is an early series of motion pictures originally approved to cover 7 titles which, under the scholarly hand of the technical adviser assigned by the Navy, finally emerged as an eruditely detailed series of nearly 30 titles! In this process of meticulous development of the subject, the limits of motion picture material were left far behind, and the motion picture medium expensively used to produce hundreds of feet of slide film material. Not only photographically are there hundreds of feet too many in the series, but educationally there are too many titles to be used in any classroom in a time of war. Only a few of the films covering the originally planned dramatic incidents and their correlated operational implications have significant usefulness at all for war training. The filming of a textbook in all its tedious details has no place in a period of war, probably no place in visual education.

In addition to these four major offenders, there are many others, good men in the main who have bad habits. There is first the traditionalist who has aped the entertainment field for years and insists that all films, both motion pictures and slide films, should begin and close with music. He is stubbornly unconvinced by evidence from the field that instructors don't want music, think it inappropriate, point out that no sensible teacher states the topic he is to discuss, turns on a phonograph for a few seconds, proceeds with his lecture or discussion, then closes triumphantly with a few seconds more of music. Nuts-and-bolts films are not enhanced with strains of a wedding march. Secondly, he can not follow the reasoning that, psychologically, music is unsound in a training atmosphere. It calls back the motion picture theater experience of the class members and

they expect to be entertained. It does not put them in a thoughtful work attitude. Frequently, resentment is expressed or deflation experienced when the film does not live up in excitement to the music promise. The teaching purpose of the film is hampered, often defeated, by the theater mood aroused by music.

Second, there is the man-who-works-by-formula. His bad habit may take any of a number of forms. One of the most frequent and tiresome is the formula that calls for a parade of action shots to open and close the film. Those of us who see many films get frightfully tired of seeing over and over again the same stock shots of majestic ships steaming full speed ahead with all guns firing, the same plane formations gradually filling the screen, the same depth charge explosions or torpedo wakes—all photographers' dreams, but deadly monotonous when used in 20, 30, 40 films!

This particular addict of a formula generally feels it necessary to put meaning into his film by showing the bewildered machinists mates in his audience: (a) that there is a war on; (b) that the Navy has its part in the war; (c) that the Navy's part is a fighting part; (d) that the Navy fights from ships or planes; (e) that his particular gadget, engine, or what not, is frightfully important in the Navy's fighting program; (f) that Victory *really* depends, however, on the Men of the Navy, (g) and *particularly* and especially on the men for whom *this* film was prepared!

Now this is all at least partially true. But why labor the point in each film, or in a full introductory film on each series? It rather loses its punch after a while, you know. And the formula can only be developed by using the same stock shots each time or minor variants of them. Why not get to the *real* purpose of the film quickly and vigorously, the disassembly and assembly of the Mark 23, Mod. 4, Gadget X?

The last bad habit singled out here is cartooning. Certain slide film directors and writers have had it bad, and in a particularly obnoxious form. The film progresses steadily on its way, showing the assembly of confidential weapon Z. Then suddenly, at a whim of the writer, a plane, a submarine, a ship metamorphoses into Hitler or Tojo, and goes plunging in great pain to the bottom of the sea as a result of the perfect functioning of the properly assembled confidential weapon Z! Startling, what? And not particularly funny after the forty-first time!

Now, of course, there is a place for all these devices. Humor, high-

grade, unexpected, natural humor greatly enhances the value of a training film, just as any good humor improves a classroom. Recently the Training Film Branch had a request from the Secretary's Office for the production of a training film on dictating letters in the Navy. The first script submitted was dry as dust, and patronizing, something that simply would not get across to the type of experienced personnel who were initiating Navy correspondence. Our script consultant and education officer suggested a script that burlesqued certain well-known dictators who were problems to their stenographers. So Mr. Scatterbrain appeared on the screen; the guy who has his desk piled high with letters in no order; who paws through the pile as he needs a certain reference while his stenographer waits and waits; who starts letters, but does not finish them because he has not thought them through, and so on. You know the type. Mr. Speedwell was next, the machine-gun dictator who goes so fast that his poor stenographer can not possibly get him the first or second time through. Mr. Trotter was shown, who goes pacing up and down, muttering his letters to the walls and windows, and expects his girl to take down his words. And several other types.

The picture is well done. It gets its laughs! But it does a job; it has already changed habit patterns in our own office! Men see *themselves* as they laugh at the screen, and change their practices. Similarly, humor has been used in films on safety in gunnery—Dilbert has been put on the screen. And even in nuts-and-bolts films on disassembly and assembly of gyroscope units humor has been used effectively: the ordinary dud who is all thumbs is a laughable contrast to the proficient instructor-Chief who demonstrates the right way of doing the job.

Even the orientation aimed at by those who review the Navy at war is fundamentally sound. Placing a job in its setting, ingeniously, and convincingly, is good teaching. The psychology of learning is perfectly clear in its documentation of the fact that material which has meaning for the learner in terms of his purposes is much more easily learned than isolated, unrelated material. But most of our films are used in a classroom setting, when the instructor needs to show it, and with an introduction by him showing its relationship to the total job of training for Navy service. The film is an aid to his teaching, does not stand by itself, does not need to carry the whole burden of orientation and teaching.

In spite of the diatribe earlier in this address against the formulistic

use of action footage, there is a place for its use. In operational films, there is no effective substitute for showing the actual thing. Words, diagrams, model replicas are pale substitutes for battle action, formation flying, PT boat maneuvers. Our medium has its basic excuse for being in training in its photographic possibility of reproducing the real thing so that men can see, feel, and understand the activity they must learn.

The criticism here has been meant to show the *poor* uses of good possibilities. Good motion picture craftsmen can use their medium effectively to make teaching easier and better.

It is not a simple job we have to do, but it is a definite one. We must clearly define our purposes, and analyze our subject matter till we *know* what is to be taught and hence, what is to be photographed. We must know what our audience is to be, what their vocabulary level and idea level is, how near the kindergarten or the graduate school they are, so that we can know what photography and what commentary they can take in. We must know the teaching situation into which our films are to fit, so that we can cut our films to a usable length, and plan the number of titles in our series so that all of them can be used in the course scheduled.

We must decide what can be carried in our film medium—motion picture or slide film—and what must be left to others to produce in booklets or charts. We must decide on the photographic approach—live photography, animation, model photography; and on the script approach—dialog, commentary, serious narration, semi-Pete-Smith style, thought voice; whatever we may need.

And from then on, during all phases of production, we must see that narration, photography, animation, and effects all contribute to fulfilling the teaching purpose of the film. This, too, is no simple job. Many a good film has been ruined in the cutting room by a cutter who does not understand what is wanted. Hollywood's purposes, and the newsreel, have cramped and limited many a skilled cutter till he is of little use for training film production until retrained. One of our producers recently sent its writers, cameramen, and cutters, as well as its directors, for a month of indoctrination into the training needs of the Navy Yards as it started a series of 50 training films on shipbuilding skills!

For the production of training films is a team game, with many specialists contributing to the result. Many skills and many creative ideas can go into the making of effective training instruments if

all who work at it understand what is wanted—interesting, clear, accurate, convincing training aids. As the Navy gets them, its men will be trained faster, their work will be better, and—who knows?—the war may be won more quickly.

THE TRAINING FILM PROGRAM IN ACTION A CASE HISTORY*

HOWARD E. CARR, EDWARD NELL, JR., AND THORNTON SARGENT**

Summary.—This is the story of a series of training films. It is one of many series being made on the vastly complicated mechanisms by which the Navy controls the fire of its guns. The original request came from the Fire Control and Gunner's Mates Schools in July, 1942, was approved, and assigned to a producer. Training Film Branch personnel, School staff, and producer's representative began research; began writing; began production. Some of the sailing was smooth, for possible snags had been foreseen. But others had not been anticipated. These included the use of color in presenting complicated, difficult, and technical material; and the changes and modifications in equipment that were effected after films were started but before they were completed. Securing writers with the necessary training and experience was difficult owing to the nature of the subject matter.

But these problems were tackled as they came along, and most of them have been solved, even including a revision of the curriculum of the Fire Control School in order to make full use of films.

This is the story of how some of the training films in the Navy have been produced. It begins with the arrival in June, 1942, of a young officer in Washington to take charge of the Ordnance and Gunnery Schools. He had recently stood on the deck of a ship at Pearl Harbor encouraging his men to fire at the Jap planes with any and all guns available. He was made Officer-in-Charge of the Fire Control and Gunner's Mates Schools because of his background as a gunnery specialist in the Pacific area, and he knew the need for well-trained gunner's mates and fire controlmen.

After December 7, he recognized the need for immediately training reserves to handle the complicated mechanisms in the shortest possible time. Being familiar with Navy training and the existing facilities for instructing, he realized new methods and procedures must be adopted immediately. To render instruction accurately, definitely

* Prepared for the Technical Conference in Hollywood, Oct. 21, 1943, but not presented.

** Lieutenants, USNR, Training Film Branch, Bureau of Aeronautics, Washington, D. C.

and to the point, not in 6 or 8 months but within 2 or 3 months, and with a slight knowledge of the teaching film medium, he resolved to experiment and develop such instruction in his schools which he was to command. In other words, a pointing out of the visual needs was a factor uppermost in his mind when he received orders for his new billet.

The general public knows what a gunner's mate is, but the term "fire control" may need a little explanation. Fire control systems are so designed to direct the fire from a ship's guns that the enemy may be destroyed before he has a chance to strike back. It is the heart and purpose of any vessel of war. The ship exists solely for the purpose of transporting these specialists with their weapons within range of the enemy where they can bring into action the modern offensive weapons of the Navy.

When this officer took over his duties at the advanced Fire Control School, he found approximately 100 students with inexperienced instructors, and a great need for proper training facilities. The instructors, many of them chief petty officers from the Fleet, knew their subjects thoroughly, but their teaching technique was slow and leisurely, and not in the tempo of World War II. In a brief 12 weeks they were expected to make trained fire controlmen out of farm and city boys alike, most of whom had insufficient background and training for their new jobs.

The officer was faced with the task of expansion of the school and its facilities to provide trained men for the great number of new ships that were being commissioned. He realized that it would take months to locate and train additional instructors. He realized further that certain branches of the Navy were making good use of visual aids to supplement their training program. An investigation of other activities, and a survey of his own situation convinced him that proper use of films would provide him with the best answer to his problem.

No available film material on the required subject matter existed. This meant that all films must be tailor-made to provide the most complete and extensive training in the shortest possible time. The survey also indicated that there were approximately 1000 subject items which offered possibilities for film utilization. Obviously, the preparation of 1000 films would also take time. The subjects were therefore grouped as *urgent*, *badly needed*, and *desired*.

A request was then made to the Bureau of Aeronautics *via* the

Bureau of Personnel for assistance, the Bureau of Aeronautics having been charged with the responsibility of providing training films for all naval activities. Through the Training Film Branch, Photographic Division of the Bureau of Aeronautics, a contract was awarded to a producer and work was started on the first group of films in August, 1942.

Representatives of the producer, the Fire Control School, and the Training Film Branch held a series of conferences in order to establish the format and style of presentation. It was considered desirable to start with relatively simple material and to use sound slide films as the medium of presentation. Writers, technical assistants, educational specialists, production specialists, and the producer all worked together to achieve the purpose of quality visual aids produced in a minimum amount of time. This group is still working together, and the results have been splendid. Each individual represents a different approach or view, and each one contributes something valuable to the final production.

Their method of working was straightforward. They selected a subject which occupied about 2 weeks of classroom time in the course of study as planned; for example, the basic mechanisms of the gun director. The curriculum director of the school brought with him a copy of the course of study as then planned. The instructor assigned as technical expert brought his knowledge of classroom procedure and problems. The writer and the Training Film Branch representatives brought their ideas relative to film presentation of the subject. Hours of discussion followed, with attendant benefits to the readjustment of the actual teaching schedule resulting. In one particular case, an enthusiastic writer proposed some 40 films to cover a subject that was allowed only 9 days of instruction time, an impossible number when the requirements of shop and laboratory work, classroom discussion and study, were considered.

Further discussion clarified the specific operations and principles to be pictured, and the writers and artists went to work to write the scripts and organize the accompanying story-boards of the series. First drafts of these were submitted to the same group of curriculum men, technical experts, and training film field representatives, for discussion, change, or approval.

When the whole group approved and initiated a script and story-board, it went to the Technical Adviser on the project, and to Training Film Branch administration officers, the Education Officer, and

the Project Supervisor for their approval. Frequently, new conferences were necessitated at this stage, but when everyone was satisfied, the producer went ahead with full confidence that if he worked within the specifications agreed upon, his product would be accepted.

The first film was finished in a relatively short period, and it looked as if the production of suitable films would be a simple matter. As the program was expanded, the subject matter became more complex and technical, and many problems were to arise which were wholly unforeseen. The writers available had no knowledge or experience in the intricacies of fire control. Occasionally, they would bog down completely and once again assistance would have to be rendered by a gunnery specialist. It was necessary to weigh the various opinions and arrive at the best answer.

It was often necessary to completely revise an entire script because of change and modification in combat tactics and ordnance equipment. These changes often came about overnight. To keep pace with such developments, it was considered advisable to establish an assembly-line production of films. By October, 1942, more than 50 people were giving full time to the preparation of film material on this one project. This number included naval officers, enlisted personnel, writers, artists, photographers, and others. Although progress on the production line basis had been made, film deliveries were not entirely satisfactory. New problems in production continued to arise. To enumerate them all would take too much time, but here are a few typical ones.

First, a clear-cut definition of the film's purpose was lacking owing to the fact that several requests for film treatment of the same subject matter had been received by the Training Film Branch. The Electrician's School might want a film on electricity; the Fire Control School would ask for a film on the same subject, but emphasizing their own peculiar problems. To decide whether the two requests conflicted, whether each needed a specific treatment, or whether the two requests could be combined, was a task even Solomon might have shirked. In the resultant conferences, decisions would be reached, but, in the meantime, valuable time would be consumed. This is one problem that is still giving us trouble.

Second, when a script was written and submitted for approval, differences of opinion would again show up. Each opinion might be valid; one officer might base his opinion on North Atlantic experi-

ence, while another officer might base his opinion on experience around the Guadalcanal area. All opinions had to be given due consideration and included if possible. It was up to the Training Film Branch personnel and the Technical Adviser to determine what was best, and to accept the responsibility for the decision.

Third, what was the best medium for presenting the subject matter? Opinions on this question varied also. One subject would lend itself to very clear presentation by straight photography, while another subject might require all animation. Another subject could best be presented by stop-motion, while still another might require line drawing. Occasionally, a subject would be presented which could be shown by simple block diagrams. Ofttimes, the request would specify the subject be treated by animation when, in fact, it should be treated by straight photography or the use of models in order to save time and expense.

Fourth, and perhaps the greatest problem, is that of determining the exact visualization. Where the subject must be presented in other than straight photography, must the eye always see on the screen what the brain knows to exist, or can ideas be presented in lieu of visual details? The requesting authority has insisted upon the visual presentation of minute technical detail. This problem constantly challenges the best thinking of personnel charged with the production of training films.

Fifth, it has been necessary to use color film for a clear presentation of some of the more complicated aspects of the fire control mechanisms. In one instance, it was necessary to trace visually a large number of electric circuits in one piece of equipment. It was even necessary in some instances to combine such electrical circuits with complicated hydraulic circuits. The problem did not end with the decision to *use* color, but included the choice of suitable colors against effective backgrounds, the proper separation of these colors on the screen, and the extensive and continuous testing of various types of color to present effectively the intricate detail desired. Although satisfactory results have been obtained, there is a great field of experimentation and achievement in the use of color in the training film program which has not been touched upon. This was caused mainly by the limitations of personnel and time and, to a certain extent, by the shortcomings of existing color processes.

The Requesting Authority considers that the technical information is now being presented in a satisfactory form. They are now

concerned about literary style of narration and art quality. Perhaps this is a good sign that progress is being made as far as the technical problems are concerned.

During the past 12 months, approximately 50 units of slide film and motion pictures have been produced on this one series; this is at the rate of about one per week. Gradually a production procedure has been established which will provide a smooth flow of subject matter and material into the hands of the producer in such condition that he may maintain an assembly-line production. This is largely because of the fact that each specific training problem has been thoroughly analyzed by qualified personnel of the Training Film Branch. This analysis and initial research, conducted by the Education Officer, the Production Consultant, the Graphics Consultant, and the Script Consultant, anticipate and prepare for most of the difficulties and problems which may be encountered. A parallel planning procedure has been adopted by the Requesting Authority so that the initial research prior to the placing of a request for the production of a film is based upon the same factors and standards as those of the Training Film Branch.

From the economic standpoint, it is only fair to say that costs have been relatively high. However, these costs have been high owing to the technical nature of the subject matter, to necessary experimentation, to the use of color, and to the fact that equipment must be photographed at varied locations and at hours which do not interfere with the normal operations of the school or the factory. It is now possible, as a result of established procedure, to anticipate more closely the costs and to establish contracts accordingly.

At the present time, there are 267 units of slide films and motion pictures under contract for production on this one project. Approximately 50 of these have been delivered, and the remainder are planned and scheduled for delivery within the next 6 months. As production facilities are available, other subject series will be added to this number.

Briefly, the problems accelerating naval training which became apparent after Pearl Harbor have been, in part, solved by the use of visual aids. The results which have been achieved are too numerous to mention here. But in one particular curriculum it might be pointed out that the total training time was reduced from 115 to 32 hr, with a higher average of retention on the part of the stu-

dents. The elementary class *A* Fire Control Schools at the large naval training stations are furnishing qualified personnel more rapidly to the associated advanced Fire Control Center. This is the result, in part, of an intelligent employment of a specific film training program, related in our case history.

These films are designed for and distributed to all Navy Ordnance Schools in the country, and to a majority of all fighting ships at sea, and to U. S. Navy Bases scattered all over the world.

The need for these films is increasing. The better the films, the more effective our Navy will be in executing its mission—the total defeat of our enemies in the Atlantic and in the Pacific.

LIKE THIS*

PATRICK MURPHY**

Summary.—Experience gained from the production of training films for the armed services is discussed in its application to post-war technical problems.

Automobile motors of basically new construction—brand new mechanical, electrical, and electronic contrivances for the home—new modes of personal transportation, including the low-cost helicopter and gyroplane—revolutionary applications of *radar* to communications and industry!

These are only a few of the post-war developments that seem certain.

All of them involve something in which you people in the motion picture industry have a big stake—*visual training!*

Mr. and Mrs. America must be taught in the clearest, speediest way possible—which is always *visual*—how to run, how to maintain, how to repair the new machines of a new era.

The problem of mass visual training in post-war years will probably equal in magnitude the one we have faced in the armed services.

You all know what a problem *that* was and is! Our military training job involves teaching hundreds of war-winning technical skills to millions of nontechnical persons—and doing it faster than ever before in history.

It is now a matter of record that training films are proving essential to the accomplishment of that job. In many cases, they have reduced by 50 per cent the time needed for the mastery of vital skills.

From this experience I think an important conclusion logically follows: *If training films can help win a war, they can also help win a peace!*

In the post-war era to come I envision a compact, inexpensive motion picture projector in practically every home, possibly furnished with the new car you will buy.

* Presented Oct. 21, 1943, at the Technical Conference in Hollywood.

** Commander, USCGR, Chief of Visual Training Section, U. S. Coast Guard Washington, D. C.

I also envision a training film kit on operation and maintenance as being automatically included in the sale of every major appliance of any technical complexity much the same as the service manual came with your new car.

It could be that this film kit and projector will all come in one compact case. Unless I'm greatly mistaken, training films will achieve a strong *number two* position in your industry's scale of economic importance—ranking second only to straight entertainment.

Some of you, of course, may wonder why operation and maintenance textbooks in the post-war world should be printed on celluloid. Why not continue printing them on *paper*, as we've done for years?

The answer lies, I believe, in the magic of two simple words—two words that can do a better teaching job than 2000 in conventional instruction books.

Those two words are, *Like This!*

How do you tie a square knot? You do it, gentleman, *like this!* (Speaker quickly demonstrated with two lengths of heavy cable.)

How do you open a 0.45-cal revolver for inspection? You do it *like this!* (Speaker demonstrated.)

How do you light a match? You do it *like this!* (Demonstration.) Instead of doing the "like this" as I have just demonstrated, we will show you the process on film so all of you can see it.

Of course, instead of using the visual "like this" method, we could have covered the subject of match lighting in a conventional instruction booklet. Probably it would have started off this way:

Section 1, Paragraph A.—To light a match, first grasp the hexagonal, or rounded shaft of the device firmly between the forefinger, thumb, and the two fingers to the right of the forefinger. Then elevate the device above a frictional surface, or a non-frictional surface suitably treated with a combustion-provoking compound.

You are now ready to take the next step in match-lighting, which we shall discuss in *Section 2, Paragraph B.*

Well, that's *one* way to teach a new skill—if you've lots of time and are a puzzle "figure-outer." But when minutes count, there's no substitute for the "like this" method when the "like this" is shown on film. Let me demonstrate with a few actual excerpts from some representative USCG Training Films.

CINEMATOGRAPHY GOES TO WAR*

WILLIAM R. MCGEE**

Summary.—The title of this paper, *Cinematography Goes to War*, is self-explanatory. It deals with the science of motion pictures as utilized by our Armed Forces in modern warfare. Principally, this paper concerns itself with the Army Air Forces which, within little more than one year, developed the First Motion Picture Unit at Culver City, Calif. The importance of motion pictures in the over-all war effort can not be overemphasized. In the fields of reconnaissance, news values on the home front, and visual aid instructions that are saving American lives and property, cinematography today plays a foremost role.

To correctly understand what the First Motion Picture Unit is doing, we must break its functions into two phases: the first trains combat cameramen who go into the thick of battle to photograph occurrences that are of inestimable value to our High Command; the second covers the making of training films. These, too, can not be underestimated in importance. To our Air Forces such films are as valuable as arms and planes. For through their auditory and visionary instruction are saved the lives of hundreds of American airmen and thousands of dollars worth of American planes.

The title of this paper is self-explanatory. It deals with the science of motion pictures, as utilized by our Armed Forces. But in this case we shall concern ourselves only with its employment by the Army Air Forces in modern warfare.

To properly introduce our subject I will go back to June 27, 1942, when the Army Air Forces First Motion Picture Unit was activated. This Unit today is an important cog in the over-all war effort—so important that its present installations in Culver City, Calif., are being constantly enlarged. We will treat later, in detail, with the work of the First Motion Picture Unit.

Many of the motion picture technological innovations developed by the Armed Forces must of necessity remain secret for the duration. But when the war is won, and these advancements are finally made public, I can assure you that it is these very innovations which will interest you most, for they will contribute much to the future progress of your great industry.

* Presented Oct. 22, 1943, at the Technical Conference in Hollywood.

** Lieutenant, Army Air Force, First Motion Picture Unit, Culver City, Calif.

The importance of motion pictures in modern warfare can not be overemphasized. In the fields of reconnaissance, news values on our home front, and audio-visual training education, cinematography plays a foremost role. This last field, audio-visual instruction, is directly responsible for the saving of thousands of American lives and many millions of American dollars. To illustrate, let me tell you about one training film produced by the First Motion Picture Unit.

The *P-40* and Japanese *Zero* resemble each other so much that it is difficult to tell them apart in flight. It became necessary for our pilots to learn their positive identification in a split-second glance. We produced such a film, using a captured Jap *Zero* for authenticity. The salient characteristics of each of these planes were driven home with such force that even the greenest fledgling can now be trusted to identify the *Zero* at a glance.

In these training films animation plays a vital role. By means of animation are illustrated many identifying characteristics, as well as other vital points. When projected on a screen during the running of a training film, of which these animated sequences are a distinct part, and woven cleverly into the theme of the film, they stamp indelibly on the minds of embryo pilots the points their instructors wish them to learn—and to retain.

To correctly understand the work of the First Motion Picture Unit, we must divide its functions into two separate and distinct phases. One trains combat cameramen to go into the thick of battle to photograph occurrences that are of inestimable value to our High Command. It is their films, too, made under the stress of actual battle, that you often see in the newsreels labeled, *Army Air Forces*.

The second phase covers the making of training films. These, too, can not be underestimated in importance. To our military strategists these films are as valuable as arms and plane.

The business of fighting our enemies is not altogether done with guns, for it is equally important for us to fight to save as many lives as possible. This is even more important, for to save the life of a flyer means not only saving a life, but it also means saving months of training and probably a plane worth many thousands of dollars.

Army Air Forces Headquarters in Washington fully realizes this. Upon their special orders, special commands of the Motion Picture Unit are now operating at every front in every theater of war, and

these groups are steadily being increased in size and number as the United Nations open up new fronts. Their work is clearly cut out for them. Theirs is the task of recording on film any and all things that will (1) aid in saving the lives of our men; (2) expose any and all weaknesses in our planes and machines so that these can be corrected; and (3) reveal the enemy's war machines so that we may learn his secret tactics, and modes of operation, his strengths and weaknesses.

The motion picture camera as a reconnaissance weapon in battle zones is still limited by the need of complex processing machinery. The best film in the world is worth nothing unless it can be brought back safely and processed for projection on a screen. Owing to this lack of front-line processing facilities, the undeveloped reels are sent back to this country from the war theaters. Here they are processed and go to the High Command in Washington to be broken down and distributed as determined by our military strategists.

It is for this reason that still cameras are widely used in reconnaissance photography. They provide mosaics, which are readily processed and pieced together in the field for immediate study by field officers at command posts. They have developed, too, a trimetrogon system of photography which makes their mosaics excellent reconnaissance maps. The subject of still photography is another matter entirely, so we shall dispense with discussing it further at this time.

Some of our films taken in combat are extremely confidential. They are used by our strategists to determine and map future military campaigns. They yield information that even the ablest observer can not duplicate with the naked eye. Such films are studied over and over again. Often they are obtained at great risks, but their values are so great that these dangers must be endured in order to collect data needed by our strategists for waging modern warfare.

Certain news shots brought back from the fronts are released through the newsreels. These give the American people a "camera's-eye view" of what takes place during battles and campaigns. The morale of the people on the home front is important. It is *their* menfolk and *their* dollars that fight for victory. Whatever news can be given them, without endangering the war effort, is being given them by our High Command. And for the dissemination of news, motion pictures are among the best mediums.

I have hesitated to tackle the technological aspects of cinematography at war. Modern warfare is a battle of sciences, and the science of motion pictures has been advanced by our technicians along with other technical improvements. New developments, as long as they are unknown to the enemy, are carefully guarded secrets, even on the home front.

You know as well as I do the exigencies that surround cinematographers in extremely hot and cold climates. The *Tropical Pack*, created by the Eastman Kodak Company, is used extensively by our Air Forces in tropical areas. It is still among the best such developments for the handling of film in temperatures where even thermometers shatter from the heat. Dehydration shipping packs, where the film is placed in insulated boxes whose walls contain dehydrating fluids that keep the temperature down, keep the emulsion normal and the film from melting. These protections decrease the danger of film being ruined by bacteria. Any new advances made by our fighting forces in the handling of film under adverse conditions must certainly prove a boon to the motion picture industry after the war. Think what these improvements will mean to your companies going on location! But the advancements that have been made are not open to discussion at this time.

Extreme cold has posed even greater problems for Air Force photographers than extreme heat. In our bombers on some missions the temperature often drops so low that the oil in the cameras freezes, slowing down their action. Cameramen sent on these missions exercise many precautions in order to bring back usable film. They remove all the oil from their cameras to keep it from coagulating. The spring tensions of their cameras require special adjustments for shooting at high altitudes in extreme cold. To obtain more action on a single wind of their cameras, they substitute more powerful springs. The stronger springs yield as much as 50 ft to the wind, as compared to 30 ft in normal springs. These are just little tricks of the trade that our combat cameramen are applying in action.

Whenever possible the Mitchell, or Akeley, or similar tripod camera is used. But on flying missions these larger cameras require too much space. Here the cameramen rely on hand-held "jobs"—the Eyemo for 35-mm stuff, or the Filmo and Victor for 16-mm stuff. Remember, the cameraman must shoot from whatever opening he can find in the plane, but under no circumstances can he interfere with the operations of the ship or its crew. It is far more

important for that bomber to return to its base with its crew intact, than it is to bring back good motion pictures.

There are, of course, exceptions to the rule. There are occasions when planes fly purely on reconnaissance missions, and for them it is the bringing back of good films that counts most. The development of multiple camera mounts, and the types of ships these are used in, are military secrets. Let it suffice to say that the camera's action is exceedingly fast to coincide with the speed of the ship in which it is mounted. Such a camera and plane were used by our Air Forces to bring back movies of a sunken Japanese vessel in the waters off Guadalcanal. The plane zoomed in, the pilot pressed the button and the cameras whirred. He was able to photograph the stricken enemy with accuracy, while piloting his plane, and then scooted home to safety before the Jap knew what it was all about.

Going back to cinematographers who fly bombing missions: not only are they expected to avoid interfering with the flight of that plane, but they are subject to additional demands. The protection of that bomber on that particular mission may be its own fire power. The cameraman it carries is an extra load and can not remain just dead-weight. If a gunner is incapacitated, then the cameraman steps into his place and keeps that machine gun firing. In such instances he drops his camera and becomes part of the fighting crew. Therefore, it is vital that cinematographers be trained not only for their job of taking pictures, but also as fighting flying men. Theirs is a dual role, and when the emergency arises they must be prepared to meet it. Upon their added help may hang the fate of that bomber.

To give you an idea of what our Combat Camera Units are doing, let's take a mythical bombing mission going over Germany from an airport in England. First, we shoot the "briefing," and that's quite a procedure in which the flyers are told ahead of time exactly where they are going, what's expected of them, and how they are to accomplish their mission and return home. They are made acquainted with maps and the target.

Then we photograph the loading of the ship with bombs, the crew boarding it, and the takeoff. The cameraman accompanying the crew shoots interiors during the flight toward the target. He tries to capture the gunners' expressions and reactions, if the bomber is attacked. The reactions of the crew over enemy-held territory

can lead to important deductions. If enemy fighters strafe the bomber he tries, if possible, to get into a vantage point from which to film the attack. And he must never get in the way of the crew. Over the target he may film the release of the bombs and through the open bomb bay follow their descent. If possible, he gets the resulting explosion and its destructive effect. The ship won't hover over the target to let him work his camera. Everything he gets in action is done catch-as-catch-can.

Before proceeding I might add that flak (anti-aircraft explosions) is the cameraman's nemesis. Its concussions bounce the ship so that the resulting films are jerky. It's difficult enough to shoot good films from a flying ship with a hand-held camera, but when flak enters the picture the hazards are multiplied.

Sometimes these concussions result in "jump." An excellent example of this appeared in *The Battle of Midway* film, which was released to the public. You may recall one scene in which the film jumped an entire frame. This was probably caused by flak.

Cinematographers do not accompany bomber crews on all their missions. Whether or not they can go depends on the pilot and the ship's ability to carry the added weight. We must remember that in all instances the primary consideration is the safety of the ship and the successful completion of its mission.

But back at his airport, the cinematographer finds a lot that he can do. His camera equipment is always kept at readiness. He photographs returning bombers, the extent of their damages, the unloading of wounded and the reactions of crews just back from particularly hazardous missions.

In certain war theaters even the air bases are so far advanced that they become part of the so-called front lines. If enemy ground forces attack his airport, the cinematographer is expected not only to film that engagement, but to fight in its defense as well. He is skilled in the uses of modern weapons with which he is armed, knows how to deploy through the field and remembers, above all, the admonition: "When you are close enough to the enemy to pick him off with a rifle, then it's your business first to shoot him with your camera." And it takes courage to shoot with a camera when your opponent is firing back with slugs.

That our flying cinematographers are showing courage beyond the line of duty is evident from reports we are getting about our men. Two weeks ago Lt. Bray, one of our combat cameramen, was deco-

rated with the Distinguished Flying Cross, pinned on him by Lt. Col. Mantz at ceremonies in Culver City. The DFC was awarded Lt. Bray by the War Department for "meritorious action in battle." While accompanying a bomber crew on their mission, he manned a machine gun and shot down two German *Messerschmitts*, one over Messina and the other over Naples.

The war has provided cinematographers with excellent fields for experimentation. The Alaskan and Aleutian theater offered locales for overcoming extreme cold difficulties. More important, this theater provided an excellent base of experimentation against fog. By fog, I don't mean ground haze that can be cut with filters, but mist as thick as pea soup which blankets the ship and blocks vision beyond a few feet. The problem of shooting pictures from great heights through thick fog has puzzled our technicians for a long time. When, and if, the answer is found, it will be a contribution which the cinema industry will certainly welcome after the war.

Vitally important in reconnaissance is the use of color photography. Color films show up camouflage which blends into black-and-white film. The shadow deception on which camouflage is based is ferreted by the motion picture camera when color film is used. Painted spots are isolated from the deep shadows which they are supposed to cover. Films that show up the enemy's camouflage are of such obvious importance that I need not describe their value here.

The training of combat cinematographers for the Army Air Forces takes place in Culver City, where the First Motion Picture Unit maintains a combat camera training pool. From this pool are organized the combat camera units that go overseas to do the work I have just described. Many of these men are former cameramen and technicians from the motion picture industry; others are former newsreel and newspaper photographers. Still others are men with wide experience in commercial and amateur photography.

We train them for the duties they will face. There are no punches pulled. Besides spending many hours in studying and operating cameras, practicing the loading of film magazines in change bags, and learning how to care for their equipment in the desert and tundra, the cinematographer also learns to soldier. He puts in long hours on the firing range. He learns to field-strip and assemble the weapons he will use in combat. He learns, too, how to care for himself in the field, how to utilize thick foliage and the ground for cover, and how

to camouflage himself in the brush, so that he can photograph the enemy when their forces come to grips.

The life these trainees lead is as rigorous as any that our fighting men are subjected to. He must learn judo as well as photography, for in hand-to-hand combat he will discard his camera and fight for his life.

Before he goes overseas with a unit, the combat cameraman undergoes an exacting physical examination. He is subjected to a flight test under simulated low-pressure altitudes to determine his physical capabilities for flying.

The dangers these men will face in combat are not to be minimized. On a bombing mission the cinematographer takes his chances along with the crew he accompanies. On the ground he may be called upon to fight or photograph, at close quarters, an enemy who attacks his installations.

Examples of the dangers faced by cinematography crews are seen in the filming of *A Day on the Russian Front* and *Desert Victory*.

The Russians lost 60 out of 180 photographers assigned to film that one day's fighting. In Africa, the British casualties were 17 out of 24 men sent to film General Montgomery's Eighth Army in action.

On the home front the production of training films is a major project of the Army Air Forces. The film laboratories at Wright Field, Ohio, have been combined with the First Motion Picture Unit so that Air Forces Headquarters may operate a complete installation under one roof, so to speak, for the making and handling of all its films. There have been enlisted in this phase of the work some of the industry's finest talent. The finished training films that come out of our studios are a product that would keep the movie-going public on the edge of their seats. It has to be, for it must hold the interest of our flyers and teach them facts which they must absorb through audio-visual comprehension. No longer are training films dry and exhausting movies which men sit through under compulsion. New techniques are now used to make each film a story that keeps its audience from falling asleep.

Directors, cameramen, script writers, special-effects experts, actors and every specialist technician needed to make a film tops, are engaged in the making of these films. And these men are in the Army. They are subject to military discipline at all times. They do the work, for which they spent a lifetime training, for a mere pittance

of the civilian salaries they once commanded. When they go on location—and our training film crews are often sent on locations—they live as soldiers do. This may mean sleeping in tents, barracks, or under any handy shelter that can readily be provided.

There are no individual credits given for producing a training film. It is done by a team. Every man, from the highest rank down to the private, does his duty as a soldier.

To authenticate these films requires wide research and the employment of technical advisers. In making one training film, which illustrates how the lost crew of a bomber is rescued by the ingenuity of its radio operator, we used as our technical adviser the radio operator from Capt. Rickenbacker's wrecked bomber, who was lost in the Pacific for a month. An Air Force sergeant, he was in the position to lend both technical and military advice.

The sets used in the making of our films are comparable to those used by many studios. Our Special Effects Department does an excellent job of creating shots which otherwise would cost many thousands of dollars to film. In one case they constructed a miniature chain of mountains, used in the filming of a crash landing on a mountain top. The result is so convincing that even experts must look twice to make sure it was done in miniature.

As for cameras, we work with the same tools that you as motion picture engineers employ. What advances may have been made in the matter of improved lenses are not open to discussion at this time. Otherwise, cameras and sound equipment used by us are already familiar to you.

Our Air Forces Motion Picture Laboratory uses high-speed motion picture cameras for test recording. In "structures" tests, these films are carefully studied for determination of perhaps the weakest point of the structure. Engineers pile carefully measured loads on the airplane fuselage or wing under test, while the camera records the performance. When the break begins, the camera spots the weakness at the very first tiny crack, far more accurately than the human eye could do.

The "camera observer" used in flight testing is another function of the motion picture camera. A duplicate instrument board equipped with photographic lighting is installed in the plane to be tested, and the movie camera photographs the instrument reading at intervals, governed by the test pilot who turns the camera on and off with a switch attached to his control stick.

For recording landing and take-off tests on new airplanes, technicians are also using a motion picture camera which films the plane as it flies over a measured course, spotting it on each frame in relation to markers on the course, while a time-recording device is photographed simultaneously on each frame to establish the time required to cover the measured distance.

I cite these instances to show you how the motion picture camera is employed by Air Forces technicians for important uses which the general public knows little about. These tests are very important. They tell us many things we need to know before our ships are sent into action. Then it would be too late to discover their defects. When we discover them at home, they can be corrected long before the ship is ready for actual combat.

Earlier in this paper I touched briefly on the subject of animation. It may seem incongruous that little cartoons, animations that have tickled the fancies of American children and adults alike in such films as *The Three Little Pigs*, should play an important role in a gigantic war. But that is exactly the case.

Our flyers are learning about ships in flight from such fanciful characters as Thrust, a little fellow who propels the plane on its way; Gravity, a lazy chap who loves to sleep in a hammock suspended beneath an airplane, drawing it down toward earth; and Drag, a lad with pants that balloon in the air while he hangs on to the plane's tail, holding it back. Once you see these animated characters you are not likely to forget the points they illustrate.

I might add that animation has for many years been employed by the Army Air Forces to illustrate technical procedures, because through its use it is possible to point out precisely the essential details in a new technique, or a new piece of equipment, without the non-essentials. Frequently it is impossible to obtain actual motion pictures showing the ideal operation of a piece of equipment, or the correct process to be used. But when the artist understands exactly what is wanted, it is a simple matter for him to break down the subject into a sequence of drawings that illustrate the subject exactly, without cluttering up the screen with a mass of inconsequential details.

At the First Motion Picture Unit we create animation to be worked into training films. It is no longer necessary to halt the film at a given frame and point out certain important characteristics. This is taken care of in the ordinary running course of the film by the

injection of animated sequences which then dissolve back to scenes shot from life. The process we use to prepare animations for projection on the screen is one with which you are already familiar.

To summarize the facts covered in this talk, I should like to say that all these diversified uses to which the motion picture camera is being put, would be of little avail unless there was a centralized authority to correlate and control its uses. The Army Air Forces has such an organization in Washington. It is the Technical Services Division. From this office stems the control under which our Motion Picture Unit operates.

The motion picture industry can reasonably expect to gain a great deal from our Armed Forces after the war. Technological advances are constantly being developed in all branches of science under the stress of war. Many of the cinema improvements will undoubtedly be turned over to your industry. What's more, many of our cinematographers will return to their old jobs with improved ideas—the outgrowth of improvements they developed on far-flung battle fronts. When these men go back to civilian jobs, they'll certainly apply their new technique toward advancing the science of motion pictures.

THE MOTION PICTURE PROGRAM OF THE INDUSTRIAL INCENTIVE DIVISION, U. S. NAVY*

C. H. WOODWARD **

Summary.—The Navy's Industrial Incentive Division was established in May, 1942, for the purpose of bringing home in proper perspective to the worker his important role in the war effort. The end result sought is to increase the production and quality of fighting equipment and material.

To do this, many techniques are utilized, but it was determined that the motion picture would be a most effective medium to dramatize to the worker his importance in winning the war. Accordingly, it was decided to produce incentive films for exclusive showing to workers in plants producing for the Navy.

The philosophy behind the employment of incentive films is that the worker who sees them can project himself on the screen and obtain a better, fuller understanding of the job ahead. These films are being shown now in hundreds of war plants. Reports indicate that Industrial Incentive films are proving an important stimulus to production.

In discussing the use of motion pictures to stimulate production in plants producing for the Navy, the function of the Navy's Industrial Incentive Division should first be explained.

This Division was established in May, 1942, in the office of the Under Secretary of the Navy for the purpose of bringing home in proper perspective to the worker his important role in the war effort, and the interdependency between him and the fighting man. The end result sought is to increase the production and quality of fighting equipment and material.

To do this, many techniques are utilized. These include rallies in plants featuring returned combat veterans, reports to manufacturers concerning the performance of their product in battle, posters to stimulate production, reduce absenteeism and increase quality; and information articles for trade, labor, and employee publications.

It was determined that the motion picture would be a most effective medium for dramatizing to the worker his importance in

* Presented Oct. 22, 1943, at the Technical Conference in Hollywood.

** Rear Admiral, Chief of Industrial Incentive Division, U. S. Navy, Washington, D. C.

winning the war, and to show him how the products made by him were being used in the war effort. Accordingly, it was decided to produce incentive films for exclusive showing to workers in plants producing for the Navy.

It must be emphasized again that the films produced by this Division are *not* for public showings. They are produced and exhibited for a specific purpose, for a specific audience, and in no way do they overlap the function of the private motion picture industry.

At the same time, however, when film subjects produced by private companies are found to be useful in fulfilling this Division's objectives, they are used providing there is no interference with the private companies' activities. There is no attempt either directly or indirectly to pre-empt any portion of the private motion picture companies' field.

The philosophy behind the employment of incentive films is that the worker who sees them can project himself on the screen and obtain a better, fuller understanding of the job ahead of him. He says to himself, "That's the stuff I built," and he is found cheering that product as it experiences battle. Accordingly, he finds himself a more direct participant in the war effort. He no longer feels that the war is 3000 miles away, but right at his workbench. He sees, in these films, our fighting men in action and the use of the equipment which makes these actions possible. He obtains a greater understanding of the tremendous need for equipment through the portrayal of the staggering supply problems in engagements by task and invasion forces. He is left with the unmistakable feeling that if he does not produce the goods, our fighting men can not fight.

The use of these films opens new avenues in the utilization of one of the most important mediums in mass communication. They are aimed at arousing the fighting spirit of the workers and management, and translating that spirit into more and better production. Thus, these films serve the purpose not only of creating a positive attitude, but of bringing about material, tangible results.

The Division strives, in producing these films, to attain the highest standards in workmanship and to base them on facts and figures. The audiences are treated as adults, and the messages, dramatically told, hue to the line of straight reporting, and stay within the bounds of good taste. From the reports of showings already made, there is no doubt that one of the chief reasons for their effectiveness is their sincerity and honesty.

Another outstanding feature of this new type of film is the full utilization of military photography, editing, scoring, and narrating actual combat scenes in such a way that all their potential effect is realized.

These films are divided into two categories: the first is produced with a specific "target" in mind; that is to say, they are produced to carry a specific message to a specific group of workers to promote a specific attitude and final action by these workers. For example, the film *Full Speed Ahead*, through the use of actual combat photography, tells the story of the submarine menace to convoys. This film was produced for showings to workers making destroyer escorts, popularly known as "sub-busters," and their component parts.

The second category is produced for all plants that turn out goods for the Navy. Its objective is to demonstrate to the worker, by projecting his product into every Naval engagement, that the armed forces can not fight if he does not produce, that hand-in-hand the production worker and fighting man march together.

The desired effect is to persuade the worker to remain loyally at his job, not to absent himself without legitimate reason; to step up the quality and speed of his output, to give an extra something every day. In this second category is the film, *This Is Guadalcanal*, which shows the American landings at that now historic island, and the tremendous supply problems involved. The message: were it not for the equipment produced by the men and women on the production line, those landings and successful campaigns would not have been possible, and many more American lives would have been lost.

These films are produced and edited by officers with long experience in the motion picture field, particularly the documentary end. The program calls for a specified number of short subjects produced by the Division, in addition to those obtained from other sources. For material, the Division uses newsreel and official government films, and film from private sources. Some photography and most of the mechanical work are done by the Navy, although oftentimes with the collaboration of private firms. The short subjects are produced on an extremely low-cost budget and run no more than 20 min.

When a subject is determined upon, thousands and thousands of feet of film are reviewed, and the story is fashioned to fit the available footage rather than the story being decided upon first and the footage prepared to tell it. As in the case of the Division's last film, *The Life and*

Death of the Hornet, the story of this gallant carrier which will go down in legend as the "Shangri-La" from which Jimmy Doolittle's planes bombed Tokyo, the story was constructed around the footage pertaining to the *Hornet* found available after weeks of search. The research on this story involved the interviewing of many survivors of that carrier, and one trail ended in discovering that the one person who took action shots of the *Hornet's* final battle was drowned with the film on his person.

The distribution of these films has opened a new circuit in the motion picture field—one, it must be repeatedly stressed, in which the private motion picture companies are not interested, since it is not an entertainment circuit. This circuit has as its outlets recreation halls, plant auditoriums, warehouses, cafeterias, and any available space in a plant where a projector and screen can be set up. The showing time is whenever plant workers are free to see the film, usually at lunch time, or during shift changes.

The distribution of these films is handled by private distributors under contract to the Industrial Incentive Division. When a plant producing for the Navy desires to exhibit the film, the original request must come to this Division. Once the showing is approved, the request is turned over to the private exhibitor in the area in which the plant is located. Thereafter, the plant may deal directly with its local distributor. A nominal charge of one dollar per three reels to cover the costs of handling, is in effect.

These films are being shown now in hundreds of war plants and the list is growing daily.

Reports from these plants all indicate that Industrial Incentive films are proving an important stimulus to production. As the Ajax Engineering Company of Chicago pointed out:

"Re: *Full Speed Ahead*, picture was shown in factory aisle to all shifts on regular movie hour. Many favorable comments were made and much excitement was caused by noting an instrument shown, as one of our manufacture."

It must be emphasized that incentive films are but one phase, no matter how important a phase, in the general industrial incentive program of the Navy. Essentially, they are like bullets from a machine gun; one bullet will not do the trick. The English have found this type of film most effective, particularly, as in the case of this Division, when they are tailored specifically for particular information targets.

THE SECONDARY OR PSYCHOLOGICAL PHASE OF TRAINING FILMS*

EDMUND NORTH**

Summary.—By far the larger part of Army training films is “nuts-and-bolts” pictures. About a year ago, it was decided that while the American soldier was getting excellent training in the handling of his weapons and equipment, the mental or psychological side of his training left something to be desired. To counteract the mental stresses and battlefield psychosis common to men who go into combat for the first time, the Army Ground Force Headquarters decided, in September of 1942, that a series of films should be prepared that would serve, in a sense, as precombat conditioning. From the viewpoint of the Army, this series has been an outstanding success. These films have brought a man as close to combat as he can get without actually engaging an enemy.

The Army has pioneered in using the screen as a medium for psychological instruction and conditioning. To change a man's way of thinking and acting under stress is a difficult job, but it has been found that the screen possesses the potential ability to do so.

There is no longer any need, I believe, to “sell” the idea of visual education. Prior to the emergency which led up to the present war, the Army—and certain industrial firms, as well—was experimenting with training films as a means of speeding up educational programs. By the time of the emergency, the Army had become convinced that audio-visual education, using the film medium, was a practical idea.

At that point the moment arrived for the great experiment in visual training. This country was about to embark on what is probably the greatest campaign of mass education in the world's history. Some ten million young men were to be educated in the use and functioning of the highly technical instruments of modern war.

Modern war is fast-moving and hard-hitting. It moves on wheels and tracks, and it hits with fantastic striking power. That means increased mechanization and more complicated doctrine. It means

* Presented Oct. 18, 1943, at the Technical Conference in Hollywood.

** Captain, Army Signal Corps, Photographic Center, Western Branch, Beverly Hills, Calif.

that almost every man must be a specialist. The boy who followed the plow must be taught to drive a tank. The shipping clerk must learn to master the intricacies of a 90-mm anti-aircraft gun.

This kind of mass education is a big order. In most cases the information which must be learned has no root or basis in the soldier's previous experience—no carry-over from his civilian life. There is no background in civil life that prepares a man for the firing of a 105 Howitzer, or for the clearing of enemy mine fields. These things must be learned from scratch, and *taught* from scratch.

The best way to make a man understand a complicated and unfamiliar piece of mechanism is to show it to him, let him handle it and operate it. Another good way, a supplementary way, is to show him a picture of it. If this picture moves, you can show him the mechanism or weapon being operated by an expert. And if the picture talks, as well, you can explain to the student in his own terms *what* is happening and *why* it is happening.

With animation and other devices, you can take him inside the breach of a 75-mm gun and show him exactly what happens at the moment when the gun is fired. You can portray, graphically, the mysteries of electronics.

There is no one, I think—last of all those engaged in making Army training films—who claims that training films are an end in themselves. They are intended as supplements to the Army's regular training program. They are so integrated into the training schedules that they augment and clarify the usual and necessary lectures and practical instruction.

Used in this manner, training films have proved themselves in the present war. Fantastic in complexity and fabulous in size, the job of training and equipping an army to fight our present enemies has been a constant race against time. In that race, by the expenditure of huge sums of money, increased production speed could be bought. A factory could hire more people, add "swing" and "grave-yard" shifts. Additional raw materials that were needed to meet the new demand could be procured in terms of hard cash. These things could be bought. The one thing that could not be bought was time—training time for the individual soldier.

Trained troops must take the field, and they must be *well* trained, *completely* trained, because in their grim business the price of minor error is sudden death.

In this race against time, training films played their greatest role.

It has been the experience of officers in the field, who are charged with the training of troops, that the intelligent use of films has cut down training time by 10 to 25 per cent. And that time was a commodity that could not be bought.

As a result of this practical experience over a broad field, the Army is convinced that training films are a successful and important aid to training.

By far the larger part of Army training films is strictly "nuts-and-bolts" pictures—those how-to-do films that teach the functioning of weapons and their tactical uses. This is a broad field and covers everything from *The Tank Platoon in the Attack* to *The Operation of the Quartermaster Mobile Laundry*.

About a year ago, it was decided that while the American soldier was getting excellent training in the handling of his weapons and equipment, the mental or psychological side of his training left something to be desired.

It has been found that the stresses and demands of modern war are not all mechanical. The mental stresses are just as important. The tremendous fire power and the mobility of modern weapons—the tank, the dive bomber, and the self-propelled gun—have contributed toward making the modern battlefield a scene of incredible noise and terror. Modern war is literally a hell on wheels.

Mobile warfare has placed a greater stress and responsibility on the individual soldier. No longer are lines of men massed to hold or to attack a position. Fast-striking columns pierce an enemy position or, in the case of defensive tactics, isolated strong points are strategically placed to hold ground. These comparatively small units are constantly subject to being cut off and isolated. There is no front line in the World War I sense. Attack may be expected from any direction on the ground and bombing or vertical envelopment by parachutists is a constant possibility from the air.

Perhaps most important, psychologically, is the nature of the enemy we fight. In Europe, he is a ruthless and well-trained soldier, in most cases with battle experience, fighting desperately against his inevitable destruction. In Asia, he is a religious and political fanatic, fighting with all the fervor and cruelty and treachery of a zealot.

Against these enemies we must send American boys who have been educated in the school of fair play. Good sportsmanship has been drilled into them from childhood; don't hit a man when he's down. Give the other fellow an even break.

These are fine ideals, fine, that is, for peace time, but in this war the American soldier must be taught to discard them if he is going to come back alive. In a bayonet fight, you don't want to give the other fellow an even break. And if he's down, so much the better. That's the time to hit him.

Here, again, we have a process of re-education. The American boy who would not shoot a sitting bird must be taught that it is not only right, but desirable to kick an enemy soldier in the groin, or to attack him silently from the rear with a trench knife. Blood-thirsty? Unfortunately, yes. But that is the way men fight, and if the American soldier is going to live, that is the way *he* must fight. He must learn the one bitter code of battle—Kill or Be Killed.

In September of 1942, Army Ground Force Headquarters decided that a series of films should be prepared that would serve, in a sense, as precombat conditioning. I was ordered to Washington to prepare this series in collaboration with Headquarters, Army Ground Forces, and subsequently to get the series produced. It was decided that these films, to be called the Fighting Men Series, would not deal with techniques as most training films do. These pictures were to drive home combat ideas.

Each picture of the series was to concentrate on one main combat idea and the treatment was to be dramatic. Actual combat conditions were to be simulated throughout and no punches pulled. They were to be hard-hitting, as realistic as possible, and they were to be done in soldier language.

It was decided that these pictures could best be produced in Hollywood where the facilities and experienced personnel of the American motion picture industry could bring to these films the realism and dramatization which were required. The subsequent success of the series has been due in great part to the whole-hearted cooperation of the studios and the skill of the technicians who worked on these pictures.

From the viewpoint of the Army, this series has been an outstanding success. And, equally important, the reaction of the troops has been extremely gratifying. These films have brought them as close to combat as a man can be brought without actually engaging an enemy.

Sound plays a great part in precombat conditioning, and all soundtracks used were of actual weapons firing live ammunition. In this

way, a man can be shown what a tank attack looks and sounds like and how it feels to proceed through an artillery barrage.

Perhaps the titles and a thumbnail sketch of some of these pictures will give a clearer idea of their subject matter:

Keep It Clean dramatized the necessity for the soldier keeping his weapon clean and showed the result of failure to do so.

Crack That Tank demonstrated how infantry troops can and should stand up against tank attack.

Kill or Be Killed taught that fundamental principle of hand-to-hand fighting.

On Your Own was based on individuals or small groups becoming isolated.

How to Get Killed in One Easy Lesson demonstrated some fundamental "don'ts" for the soldier who wants to live.

The most elaborate and probably the most interesting of the series is a picture called *Baptism of Fire*. In this film we attempted to dramatize common battlefield psychoses. Extensive research has revealed that all men who go into combat for the first time are frightened. Not some men, or small men, or cowards, but *all* men. It also has been found that, as a result of this common fear, there is a period of time which may vary with the individual from 3 min to 3 hr during which he succumbs to battle shock and becomes, for the time being, incapacitated. During this period he continues as a fighting mechanism only because of instinct and training. It was the intent of this film to lessen, if possible, this initial shock.

Another important combat psychosis is the sometimes overwhelming conviction on the part of the soldier that he, alone, is frightened. He sees other men moving up, assumes, erroneously, that they are not at all frightened, and becomes convinced that he is a coward.

In *Baptism of Fire* we take a soldier through his first engagement, from a bivouac area behind the lines to the final assault with the bayonet. We see his grim anxiety as he approaches the line of departure. We watch as he sees his comrades die. We move with him as the sound and fury of battle increases and becomes almost unbearable. And we see him somehow get hold of himself and stagger on. And finally, in a bayonet attack, he kills an enemy soldier who was about to kill him. It is there that he gains confidence in himself as a fighting man and conquers his fears.

It was possible, by dramatizing the experiences and emotions of this one soldier, to synthesize the fears and emotions common to all soldiers. And by examining and exploring his reactions on the

screen, other soldiers may learn what they must expect, and thus be in some measure prepared for it. The known is never so fearsome as the unknown.

In using the screen as a medium for psychological instruction and conditioning, I believe the Army has pioneered. To change a man's way of thinking and acting under stress is a difficult job, but it has been found that the screen possesses the potential ability to do so.

There has been no attempt made in this series to be inspirational. War has not been painted as a delightful or glorious experience, but simply and straightforwardly as the cold, grim, scientific business that it is.

Every attempt has been made to be intellectually honest with the soldier. He is told that his is a dangerous job, that some men are going to be killed doing that job. But he is told that if he makes of himself a good soldier, if he learns his business thoroughly, he has a good chance of coming out all right. And these are the facts. The good soldier, the well-trained soldier, the smart soldier, is the one who is going to live the longest.

The men who are charged with the training of our Army are charged also with an even greater responsibility. It is their duty to train these men not only to win battles, but to train them so well and so thoroughly that as many as possible will come back safely.

This responsibility is keenly felt in all higher echelons of command. And that is why the higher commanders say to their men, "Kill or Be Killed." They say it so that these men will return some day safely to their homes, and we can all say, "Live and Let Live."

FIFTY-FIFTH SEMI-ANNUAL TECHNICAL CONFERENCE

OF THE

SOCIETY OF MOTION PICTURE ENGINEERS

HOTEL PENNSYLVANIA, NEW YORK, N. Y.

APRIL 17-19, 1944

Officers in Charge

HERBERT GRIFFIN, *President*
EMERY HUSE, *Past-President*
L. L. RYDER, *Executive Vice-President*
W. C. KUNZMANN, *Convention Vice-President*
D. E. HYNDMAN, *Engineering Vice-President*
A. C. DOWNES, *Editorial Vice-President*
A. S. DICKINSON, *Financial Vice-President*
E. A. WILLIFORD, *Secretary*
M. R. BOYER, *Treasurer*

Directory of Committee Chairmen

Atlantic Coast Section	C. R. KEITH, <i>Chairman</i>
Papers Committee	W. H. OFFENHAUSER, JR., <i>Chairman</i>
	C. R. DAILY, <i>Vice-Chairman, West Coast</i>
Publicity Committee	JULIUS HABER, <i>Chairman, assisted by</i> HAROLD DESFOR
Membership and Subscription Committee	JAMES FRANK, JR., <i>Chairman</i>
Registration and Information	W. C. KUNZMANN
Reception and Local Arrangements	D. E. HYNDMAN
Luncheon and Dinner Dance	BARTON KREUZER
Hotel and Transportation	O. F. NEU
Projection Committee	H. F. HEIDEGGER, <i>Chairman, assisted by</i> Members New York Projectionists Local No. 306
Ladies Reception Hostess	MRS. E. I. SPONABLE

Note: In order to comply with the wartime paper conservation program only names of the committee chairmen serving our conferences will be listed in released bulletins for the duration.

TENTATIVE PROGRAM

Monday, April 17, 1944

- 9:00 a.m. *Hotel, 18th Floor:* Registration.
 10:00 a.m. *Salle Moderne:* Convening the Conference with a **General Session** and committee reports.
 12:30 p.m. *Hotel Roof Garden:* **SMPE Get-Together Luncheon** for members, their families and guests.
 2:00 p.m. *Salle Moderne:* **Afternoon Session.**
 8:00 p.m. *Salle Moderne:* **Evening Session.**

Tuesday, April 18, 1944

- 9:00 a.m. *Hotel, 18th Floor:* Registration.
 10:00 a.m. *Salle Moderne:* **Morning Session.**
 2:00 p.m. *Salle Moderne:* **Afternoon Session.**
 8:00 p.m. *Georgian Room:* **Informal Dinner-Dance.**

Wednesday, April 19, 1944

Open morning.

- 1:30 p.m. *Hotel, 18th Floor:* Registration.
 2:00 p.m. *Salle Moderne:* **Afternoon Session.**
 8:00 p.m. *Salle Moderne:* **Evening Session and Adjournment.**

PAPERS

Members and others who desire to present technical papers before this Conference should communicate immediately with the Chairman or Vice-Chairman of the Papers Committee, whose names and addresses are given on the inside front cover of this issue. Papers presented are later published in the JOURNAL. *Do not delay* sending the committee the title of your paper and the name of the author.

RESERVATIONS

The Hotel Pennsylvania management extends the following per diem rates European plan, to SMPE delegates and guests:

Room with bath, one person	\$3.85—\$7.70
Room with bath, two persons, double bed	\$5.50—\$8.80
Room with bath, two persons, twin beds	\$6.60—\$9.90
Parlor suites: living room, bedroom, and bath	\$10.00, \$11.00, \$13.00, and \$18.00

When you receive the hotel room reservation cards in March please return them immediately. No rooms will be available or guaranteed *unless booked in advance of the Conference dates.*

REGISTRATION

The registration headquarters will be located on the 18th floor of the hotel at the entrance of the Salle Moderne where all technical sessions will be held. Members and guests are expected to register and receive their Conference badges and identification cards for admittance. The fee is used to defray Conference expenses.

FIFTY-FIFTH SEMI-ANNUAL DINNER-DANCE AND GET-TOGETHER LUNCHEON

The 1944 Technical Conference Get-Together Luncheon will be held in the Roof Garden of the hotel on Monday, April 17, at 12:30 p.m.

The scheduled dinner-dance (informal—business dress and uniforms only) will in all probability be held in the Georgian Room of the hotel on Tuesday evening, April 18, at 8:00 p.m. It will be the Conference night for social get-together and dancing.

Note: Owing to existing food rationing and hotel labor problems it is imperative that your luncheon and dinner-dance tickets be procured at the time of registering, thus assisting the Committee in providing accommodations. Therefore, we solicit your cooperation.

LADIES' RECEPTION HEADQUARTERS

There will be no special or prearranged ladies' entertainment program during the 1944 Conference dates. However, a reception parlor will be available in the hotel for the ladies' daily get-together and open house. Ladies attending the Spring Conference should register with Mrs. E. I. Sponable, Reception Hostess, to receive badges and identification cards.

MOTION PICTURES

Identification cards issued at the time of registration will be honored at a number of *deluxe* motion picture theaters in New York, the names of which will be published in later issues of the JOURNAL. There are many entertainment attractions available in New York to out-of-town delegates and guests, and information concerning them may be obtained at the hotel information desk or at the SMPE registration headquarters.

W. C. KUNZMANN
Convention Vice-President

Members planning to attend the Fifty-Fifth Semi-Annual Technical Conference should make arrangements for their railroad accommodations immediately or at the latest one and a half months in advance of the Conference date.

MEMBERS OF THE SOCIETY
LOST IN THE SERVICE OF
THEIR COUNTRY

FRANKLIN C. GILBERT

ISRAEL H. TILLES

*Order Your Copy Now!**

THE TECHNIQUE OF MOTION PICTURE PRODUCTION

Covering current technical practices in motion picture production, presented as a Symposium at the 51st Semi-Annual Technical Conference of the SMPE in Hollywood, 1942. . . . Now published in book form.

160 Pages—41 Illustrations

Each section written by a specialist in the motion picture industry. . . Authentic information on various technical problems of motion picture production.

CONTENTS

I	Technology in the Art of Producing Motion Pictures.....	Leon S. Becker
II	Cinematography in the Hollywood Studios: Black and White Cinematography.....	John W. Boyle
	Putting Clouds into Exterior Scenes.....	Charles G. Clarke
	Technicolor Cinematography.....	Winton Hoch
III	Special Photographic Effects.....	Fred M. Sersen
IV	Re-Recording Sound Motion Pictures.....	L. T. Goldsmith
V	The Technique of Production Sound Recording..	Homer G. Tasker
VI	Prescoring and Scoring.....	Bernard B. Brown
VII	Illumination in Motion Picture Production.....	R. G. Linderman, C. W. Handley and A. Rodgers
VIII	The Paramount Transparency Process Projection Equipment.....	Farciot Edouart
IX	Motion Picture Laboratory Practices.....	James R. Wilkinson
X	The Cutting and Editing of Motion Pictures...	Frederick Y. Smith
XI	The Projection of Motion Pictures.....	Herbert A. Starke

THE TECHNIQUE OF MOTION PICTURE PRODUCTION is a useful and valuable reference for technicians, students, librarians, and others desiring technological data on the motion picture industry compiled in one volume.

Price \$3.50†

Published for the Society of Motion Picture Engineers by Interscience Publishers, Inc.,
215 Fourth Avenue, New York 3, N. Y.

* Ready about March 31st. Orders must be accompanied by check or money order. Use form on other side.
† 20% discount to members in good standing if ordered through SMPE.

**PREFACE TO
THE TECHNIQUE OF MOTION PICTURE PRODUCTION**

At the Spring 1942 Technical Conference of the Society of Motion Picture Engineers in Hollywood, California, a symposium was presented covering the current technical practices in the motion picture industry as applied to actual motion picture production. While information with regard to many of the subjects treated is scattered through the literature, no such complete descriptions of the various techniques involved had hitherto been assembled in such a logical, convenient, and highly educational sequence. The program was received with such acclaim by the audiences in attendance that the Board of Governors of the Society authorized the publication of these papers in book form, after their publication in the JOURNAL.

The papers of the symposium are presented in the general order of the steps taken in the production and presentation of motion pictures in the studios, laboratories, and theaters. Each section has been prepared by a man well fitted by his knowledge and experience in a particular field to give authentic information on the various problems arising in the manufacture of this great entertainment and educational medium.

It is the hope of the Society that this book will prove a useful and valuable guide to the general solution of the many problems which characterize the motion picture industry, in particular as these problems may be encountered in the post-war period of re-establishment and expansion throughout the world.

-----Order Form for The Technique of Motion Picture Production-----

**Society of Motion Picture Engineers
Hotel Pennsylvania
New York 1, N. Y.**

Date

Gentlemen:

**Please send me THE TECHNIQUE OF MOTION PICTURE PRODUCTION.
Enclosed is check or money order for.....**

Name:.....No. Copies.....

Address:.....

Member (\$2.80 per copy).*

Non-Member (\$3.50 per copy).*

* Add 1% Sales Tax if mailed to New York City address.

JOURNAL OF THE SOCIETY OF MOTION PICTURE ENGINEERS

Vol 42

MARCH, 1944

No. 3

CONTENTS

	PAGE
A 200-Mil Push-Pull Film Recording System L. D. GRIGNON AND J. P. CORCORAN	127
Wartime Cataloging of Motion Picture Film J. G. BRADLEY	145
Motion Picture Incunabula in The Library of Congress H. L. WALLS	155
Resurrection of Early Motion Pictures C. L. GREGORY	159
Walt Disney Studio—A War Plant C. NATER	170
Agricultural Motion Pictures and the War C. A. LINDSTROM	177
Report of Basic Sound Committee on Pre- and Post- Equalization for Studio Use, Research Council, Academy of Motion Picture Arts and Sciences	187
Fifty-Fifth Semi-Annual Technical Conference of the Society	193
Current Literature	196
Society Announcements	198

(The Society is not responsible for statements of authors.)

JOURNAL OF THE SOCIETY OF MOTION PICTURE ENGINEERS

HARRY SMITH, JR., EDITOR
ARTHUR C. DOWNES, *Chairman*
Board of Editors

JOHN I. CRABTREE ALFRED N. GOLDSMITH EDWARD W. KELLOGG
CLYDE R. KEITH ALAN M. GUNDELFINGER CHARLES W. HANDLEY

ARTHUR C. HARDY

Officers of the Society

**President*: HERBERT GRIFFIN,

133 E. Santa Anita Ave., Burbank, Calif.

**Past-President*: EMERY HUSE,

6706 Santa Monica Blvd., Hollywood, Calif.

**Executive Vice-President*: LOREN L. RYDER,

5451 Marathon St., Hollywood, Calif.

***Engineering Vice-President*: DONALD E. HYNDMAN,

350 Madison Ave., New York, N. Y.

**Editorial Vice-President*: ARTHUR C. DOWNES,

Box 6087, Cleveland, Ohio.

***Financial Vice-President*: ARTHUR S. DICKINSON,

28 W. 44th St., New York, N. Y.

**Convention Vice-President*: WILLIAM C. KUNZMANN,

Box 6087, Cleveland, Ohio.

**Secretary*: E. ALLAN WILLIFORD,

30 E. 42d St., New York, N. Y.

**Treasurer*: M. R. BOYER

350 Fifth Ave., New York, N. Y.

Governors

**FRANK E. CARLSON, Nela Park, Cleveland, Ohio.

*†CHARLES W. HANDLEY, 1960 W. 84th St., Los Angeles, Calif.

**EDWARD M. HONAN, 6601 Romaine St., Hollywood, Calif.

*†CLYDE R. KEITH, 195 Broadway, New York, N. Y.

**JOHN A. MAURER, 117 E. 24th St., New York, N. Y.

*HOLLIS W. MOYSE, 6656 Santa Monica Blvd., Hollywood, Calif.

*WILLIAM A. MUELLER, 4000 W. Olive Ave., Burbank, Calif.

*H. W. REMERSHIED, 716 N. La Brea St., Hollywood, Calif.

**EARL I. SPONABLE, 360 W. 54th St., New York, N. Y.

*JOSEPH H. SPRAY, 1277 E. 14th St., Brooklyn, N. Y.

*REEVE O. STROCK, 195 Broadway, New York, N. Y.

**WALLACE V. WOLFE, 1016 N. Sycamore St., Hollywood, Calif.

*Term expires December 31, 1944.

**Term expires December 31, 1945.

†Chairman, Pacific Coast Section.

‡Chairman, Atlantic Coast Section.

Subscription to non-members, \$8.00 per annum; to members, \$5.00 per annum, included in their annual membership dues; single copies, \$1.00. A discount on subscription or single copies of 15 per cent is allowed to accredited agencies. Order from the Society of Motion Picture Engineers, Inc., Hotel Pennsylvania, New York 1, N. Y.

Published monthly at Easton, Pa., by the Society of Motion Picture Engineers, Inc.
Publication Office, 20th & Northampton Sts., Easton, Pa.

General and Editorial Office, Hotel Pennsylvania, New York 1, N. Y.

Entered as second-class matter January 15, 1930, at the Post Office at Easton, Pa., under the Act of March 3, 1879. Copyrighted, 1944, by the Society of Motion Picture Engineers, Inc.

JOURNAL OF THE SOCIETY OF MOTION PICTURE ENGINEERS

Vol 42

MARCH, 1944

No. 3

A 200-MIL PUSH-PULL FILM RECORDING SYSTEM*

L. D. GRIGNON AND J. P. CORCORAN**

Summary.—This paper describes a new truck-mounted recording channel for use in a studio or on location. The interesting features include a new 200-mil push-pull modulator, limiting amplifier, together with test and lineup equipment so arranged as to make it possible for relatively inexperienced personnel to operate it without undue supervision. Circuit descriptions, operating data, and photographs are included to completely depict the recording system.

Many recording systems have been described in the literature¹⁻⁶ differing principally in the particular requirements of the user or proposed situations under which the equipment is to be used and, as improvements in fundamental design of component parts of a recording system have become available, these have been incorporated. Such is the case with the recently engineered system to be described in this paper.

Probably no system has yet been assembled with which the designers were completely happy. Compromises are almost inevitable; and, further, although the phrase "Due to world conditions—" has become shopworn, it is true that systems designed and executed at present must include more than the usual number of compromises. Some of these will be evident in the following.

Production methods of Twentieth Century-Fox require truck-mounted recording channels, and this fact had to be continually kept in mind during design. One other basic condition to consider was that, as far as possible, standard or commercially available equipment should be used, the preference being to modify equipment, within reason, rather than to completely design and build required units. Also, existing truck bodies and motor control systems were to be kept intact.

* Presented Oct. 22, 1943, at the Technical Conference in Hollywood.

** Twentieth Century-Fox Film Corp., Beverly Hills, Calif.

EQUIPMENT DESCRIPTIONS

The system of recording is Western Electric light-valve variable density providing a 200-mil push-pull track by means of a semi-intensity modulator which will be described later in the paper.

The functional block schematic of the speech circuits is shown in Fig. 1, and, generally speaking, is rather conventional. Note that the recording circuit consists of a microphone preamplifier, a mixer, 80 *Hi* 60 filter, WE RA1166 limiting amplifier, 8200 *Lo* 8800 filter and WE 100AA recorder. The WE RA1124 noise-reduction unit is bridged across the circuit between the filter and light valve so that

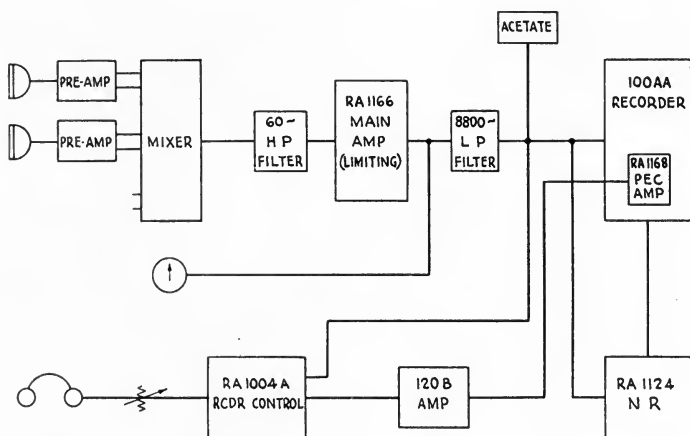

FIG. 1. Functional block diagram.

the same frequency characteristic as applied to the valve is also applied to the noise-reduction equipment. Also bridged at the output of the filter are circuits for direct monitoring and acetate recording. Photocell monitoring is provided by a photocell arrangement and coupling circuit within the 100AA recorder, a modified 120B amplifier and a single-stage push-pull amplifier in the recorder control panel. Direct monitor is also amplified by the same push-pull stage, the choice of direct or photocell monitoring being accomplished by a relay controlled at the mixer position.

The microphone preamplifier is a two-stage resistance coupled amplifier using a pentode for the first stage, a triode for the second, and incorporating negative feedback over both stages. Some high-frequency rise is provided by shunting a part of the cathode resistor into

which the feedback is introduced with a small capacitance to compensate for high-frequency transformer losses.

The mixer unit includes 3 volume control positions connected in a series-parallel combination with one dummy control, a master volume control, and a one-stage booster amplifier which incorporates the dialogue equalization and auxiliary equipments. Since the series-parallel mixer arrangement provides grounds on all circuits, hum pickup and high attenuation leakage are minimized. Auxiliary facilities supplied are: volume indicator and associated sensitivity adjustment, monitor volume control, photocell direct monitor switching, order wire and order wire connection to the monitor jack, and a jack for an external volume indicator.

Fig. 2 shows the main recording amplifier which is a modified *RA1126* limiting amplifier assigned the code number *RA1166*. The modification consists, principally, in changing the output tubes to *6F6*'s and rearranging the circuit constants to accompany this change. The result obtained is to raise the power output to +21 db per 0.006 w and increase the gain by 5 db. A further modification provides a "thump" balance potentiometer between the cathode resistors of the first stage to minimize very low-frequency noises caused by the fast limiting operation of the amplifier. The technical data on this amplifier, having been thoroughly covered in the literature,^{6,7} will not be described further. Two spare switch points on the metering switch have been brought out to provide plate current metering of the *120B* amplifier.

The Western Electric *100AA* recorder,^{8,9} being an enclosed type, offers reasonable protection to the optical assembly and bearings against dust often encountered in the use of portable equipment. Having a sturdy construction, it is well adapted to withstand vibrations resulting from travel over rough roads often encountered on trips to remote location sites.

The recorder is driven by a four-pole interlock type motor at a shaft speed of 1440 rpm. Lubrication problems are simplified since all bearings and film guide rollers employ sealed ball races. The worm and worm gears are lubricated by a constant supply of oil pumped from a reservoir located in the lower section of the compartment which houses the gear driving mechanism.

The modulator system uses the *RA1061 D* light valve and a lens arrangement known as the Western Electric anamorphic optical system. The *RA1061 D* is a four-ribbon type valve in which the 2 center

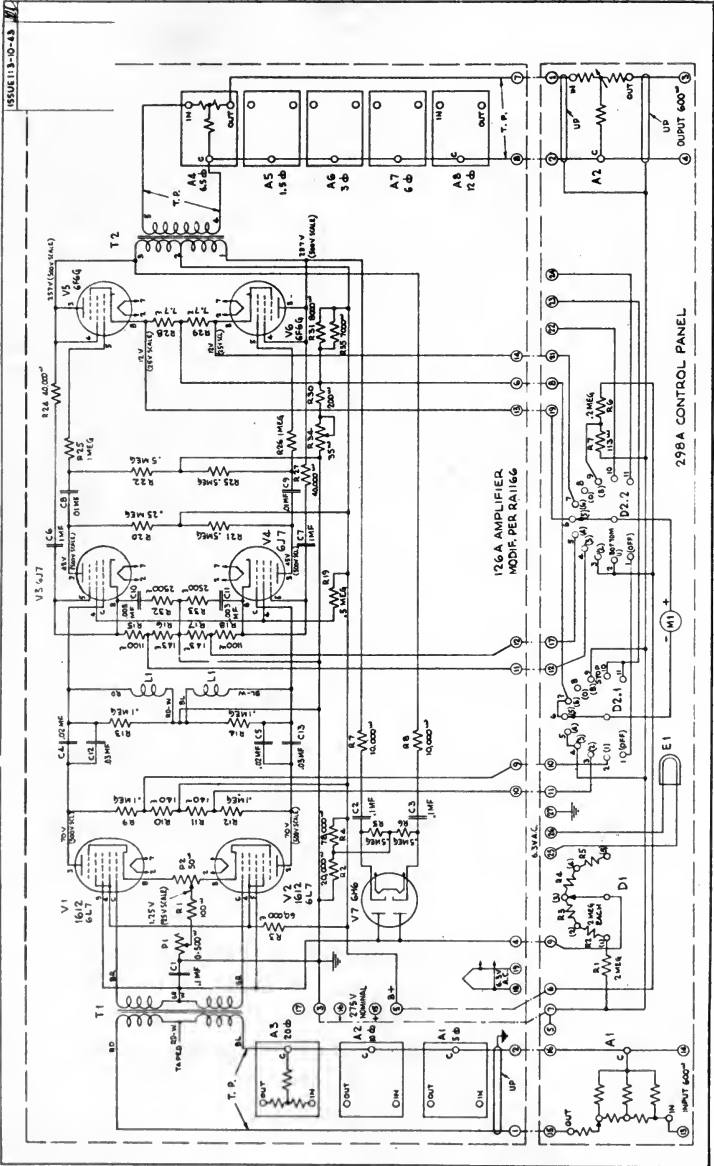

Fig. 2. Western Electric RA1166 limiting amplifier.

ribbons occupy one plane, while the outside ribbons are placed in a second plane with the planes spaced approximately 1.0 mil to provide a symmetrical biplanar arrangement. The ends of each ribbon are clamped to blocks which have insulating material completely filling the interblock space (thereby preventing the possibility of magnetic material lodging between them and short-circuiting the ribbons). The blocks further serve to permit the ribbons to be strapped for either series or push-pull connection. The details of the optics are shown schematically by reference to Fig. 3. It is noted that in com-

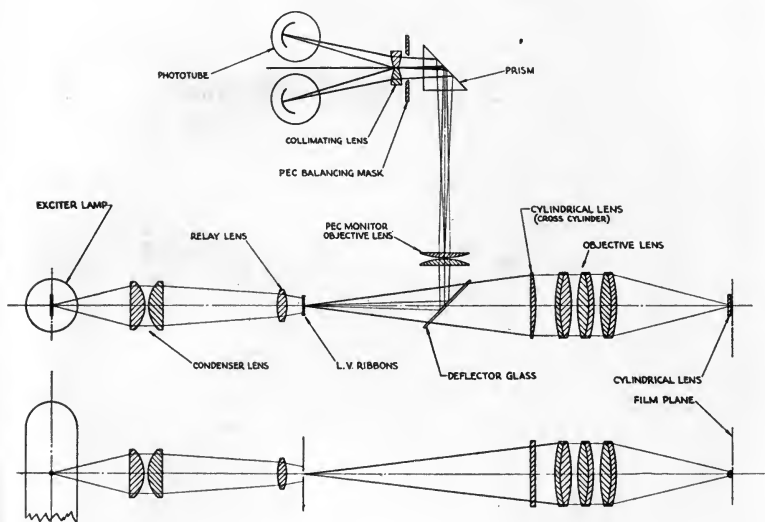

FIG. 3. Optical schematic of 100AA recorder, 200 mil.

parison to the conventional system, 3 additional lenses are employed: namely, the relay, cross-cylinder, and cylindrical lenses.

The relay lens, which is mounted within the light-valve magnet coil assembly on the valve side, serves to produce a uniform distribution of light in the area between the ribbons.

The 35-mil radius cylindrical lens is located about 20 mils from the film. It serves the purpose of decreasing the image size at the film, thereby reducing the ribbon velocity effect. This results in higher fidelity recording of the upper audio-frequency range.

Since the insertion of the cylindrical lens changes the focal point of the valve in one plane, it is necessary to add an additional lens to re-

focus the ends of the valve and septum to coincide with the focal point produced by the cylindrical lens. This is accomplished by the use of the plano-convex cross-cylinder lens. This lens, which has a value of 0.25 diopter, is installed to the left of the objective lens. The complete modulator, optical arrangement, and film path are shown in Fig. 4.

In order to place the cylindrical lens 20 mils from the film, it was necessary to remove the teeth on the sound-track side of the recording

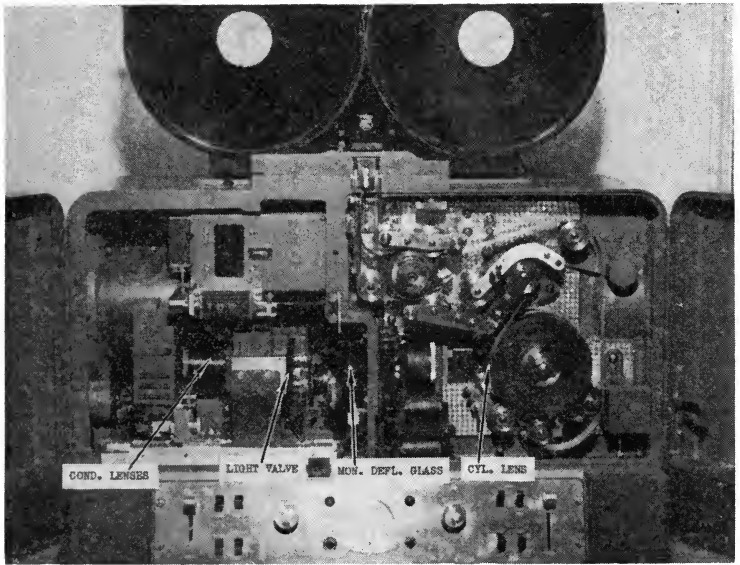

FIG. 4. 100AA recorder.

sprocket. Tests indicate that the film motion was not affected by this modification. Essentially the same optical system described herewith has been discussed by Dupy and Hilliard,¹⁰ but this constitutes the first application to the 100AA recorder.

Again referring to the optical schematic of Fig. 3, a deflector glass is noted to be located between the valve and the cross-cylinder lens. This glass, which is placed at 45 degrees to the recording light, deflects approximately 10 per cent of the light for monitoring purposes. By means of this flat glass the monitor objective lens focuses the ribbons through the prism to the plane of the collimating lens, which in turn

spreads the image to the cathodes of 2 RCA 929 phototubes. The deflector glass and monitor lenses are so adjusted that the light from each half of the 400-mil valve is projected to its respective cell.

Reference to Fig. 5 indicates the location of the coupling amplifier, monitor tube, and tone wheel.

The photocells are mounted on the amplifier chassis which is located just back of the terminal strip. The amplifier circuit functions principally as a coupling unit to reduce the photocell impedance to a

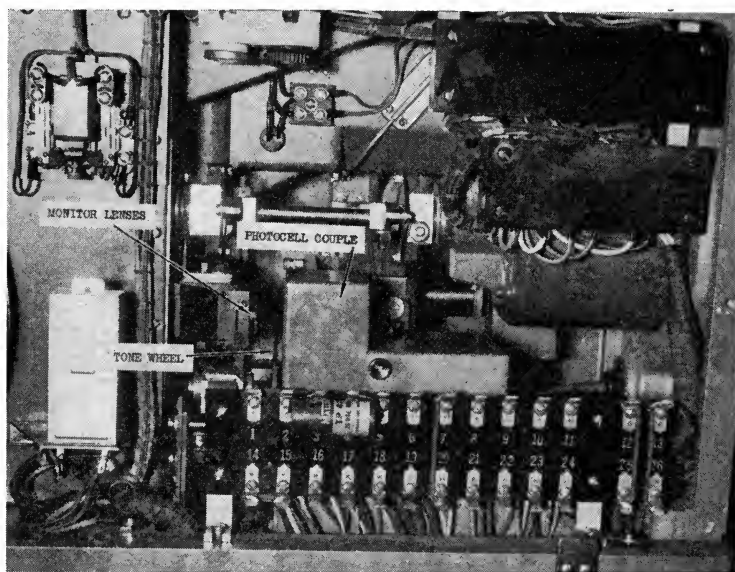

FIG. 5. Rear view of modulator compartment of 100AA recorder.

lower value without the use of transformers, and to provide a convenient switching circuit between push-pull and single conditions. This is achieved by each photocell cathode being coupled to the grid of a 6J7 tube and the low output impedance obtained by cathode coupling to the load and negative feedback. For standard coupling, that is, with the photocells working in series, the connections of the anode and cathode of one cell, to its loading resistor, are switched by means of a rotary switch which has its control lever extended toward the operating side of the machine. The complete circuit is shown in Fig. 6.

The tone wheel or light chopper, which is used in setting the bias current for the required amount of noise reduction desired, is located, together with its small driving motor, on a movable bracket just under the collimating lens. When pulled forward by a lever, conveniently located on the operating side of the machine, the tone wheel raises vertically to intercept the 2 beams of light which fall on the 2 photocells. The tone wheel, by alternately intercepting the light beams, produces a signal resembling a sine wave of approximately 600

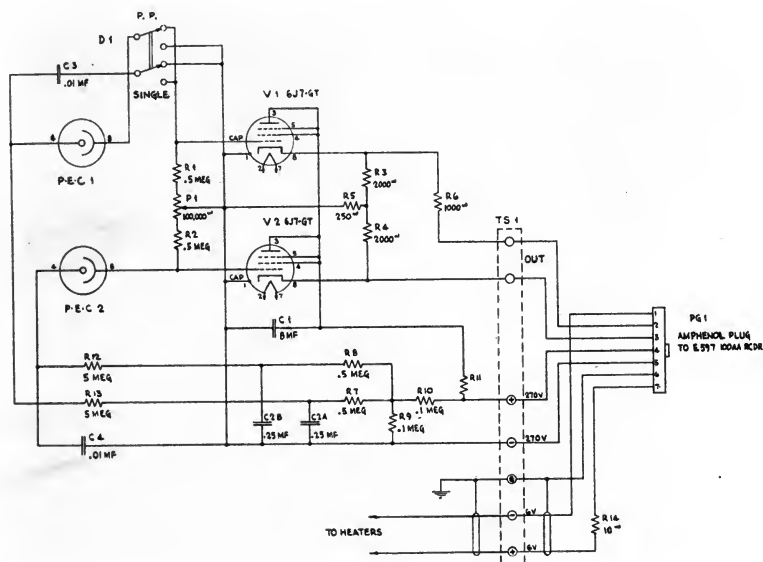

FIG. 6. Western Electric photocell coupling unit.

cycles, and thus permits the amplifier to be used under push-pull conditions. This feature eliminates the changing of the push-pull-standard switch by the recordist when checking the bias current for noise-reduction adjustments.

Owing to the low output of the photocell coupling unit, it was necessary to increase the gain of the *120B* amplifier for the use intended. The gain in this unit has been increased from 40 db to 56 db. Referring to Fig. 7, the modifications consisted of reconnecting the *6C6* tube as a pentode, readjusting the negative feedback accordingly, and changing the input transformer to one of higher turns ratio. Condenser *C7* in the feedback path serves as a convenient means to

vary the high-frequency characteristic to correct for losses in the photocell coupling and make the characteristics of direct and photocell monitoring match within the significant range.

The *RA1004* control cabinet contains the push-pull amplifier which is common to the direct and photocell monitoring, and also provides the test circuits and oscillator for operational lineup of the light valve and adjustment of the noise-reduction equipment. This arrangement was originally developed about 1938 by Daily and Corcoran for Electrical Research Products and 20th Century-Fox, and, since it is somewhat novel, it will be described in detail.

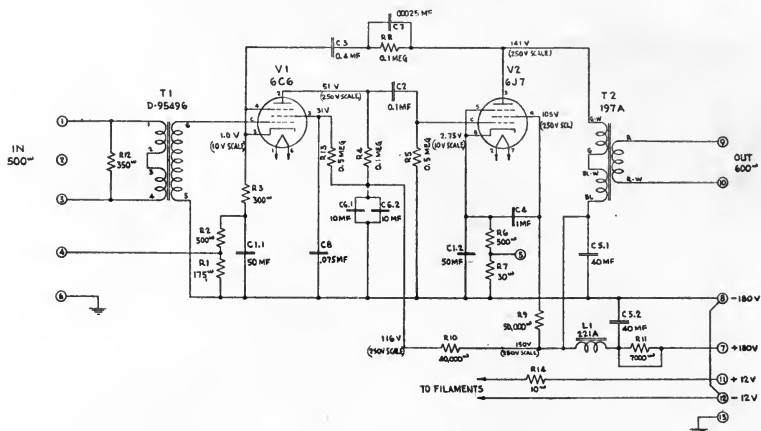

FIG. 7. 120B amplifier.

Fig. 8 shows 3 simplified circuit arrangements which are available by the operation of a multiple contact switch and a second switch to turn on the test oscillator. In *A* the circuit is such as to connect a volume indicator at the output of the amplifiers and insert a volume control. By operating the tone wheel to modulate the light passed by the valve and adjusting the gain to some reference reading on the indicator, then any other valve spacing is measured by the indicator, in decibels, from the reference spacing. In this manner the amount of bias current required to provide a given valve spacing corresponding to the desired amount of noise reduction can be determined. In the particular instance at hand, no sensitivity adjustment is provided for the volume indicator, since the scale alone provides a sufficient range.

Fig. 8B shows the method for obtaining the overload point of the valve. An oscillator, whose output is variable, is connected to the valve and 2 paths between the 120B amplifier and output amplifier are provided. One of these paths is a 40 db attenuator, the other a high-pass filter having maximum attenuation at the frequency of the oscillator and passing all multiples of this frequency without appreciable loss or discrimination. Either of the 2 paths is selected by a

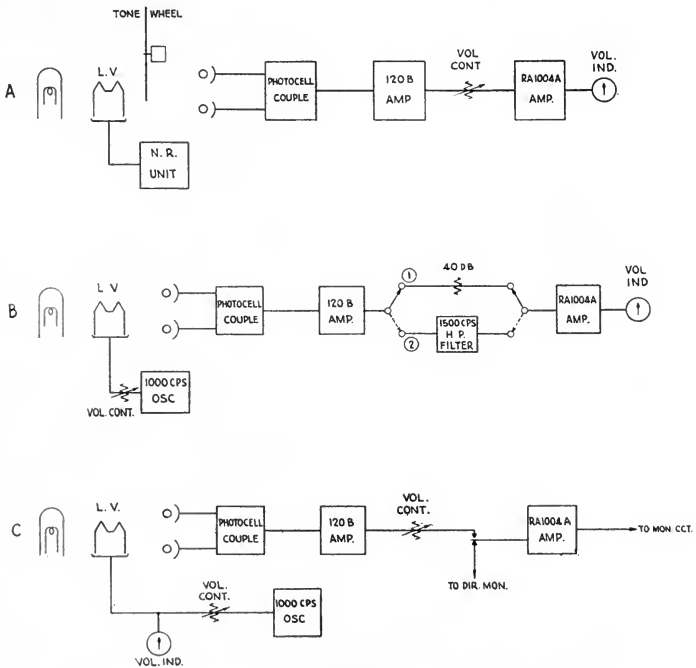

FIG. 8. Block test circuits, 1004A recorder control.

nonlocking press-to-operate key. The circuit is essentially a distortion meter so arranged that when the output, indicated by the output meter, is the same through path (1) or (2), then the total harmonic distortion present in the input signal is 40 db below the fundamental plus harmonic. Reference to Fig. 9 shows that the modulated signal produced by a light valve contains an amount of harmonics less than 1 per cent at all levels below actual clash, but near to and at clash the harmonics produced are tremendously increased. By adjusting the input level to the valve so that the output meter reads the same level

with the signal through paths (1) and (2), then at that input signal the harmonics generated are 40 db below the fundamental, or 1 per cent, and this input level is such that the distortion is being measured on a very steep portion of its characteristic. Because of the steepness of the harmonic characteristic from valve clash upward in level, a very accurate adjustment of input level can be arrived at.

You will note that the actual break in slope of the distortion characteristic corresponds more closely to the 46 db level than at the 40

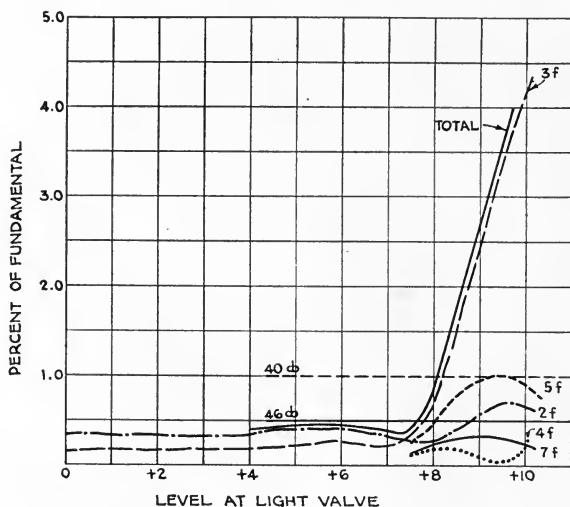

FIG. 9. Harmonic analysis of light valve, 200-mil push-pull; measured through push-pull photocell circuit and associated amplifier, and including harmonics from oscillator. Photocells are balanced.

db level as used. The 40 db level is used because (a) it more closely determines the clash level as heard by ear, (b) a margin of operating safety is provided to allow some changes in distortion from associated equipments, and (c) less total gain in the measuring system is required. This method requires that the oscillator used must be relatively free from harmonic distortion, preferably less than 0.32 per cent. Usually this method of determining valve overload on standard track systems is used with a 35 db pad to measure 1.8 per cent distortion, but on this system, since the photocell circuits are push-pull, the even harmonics are suppressed and therefore the actual distortion measured is principally the third.

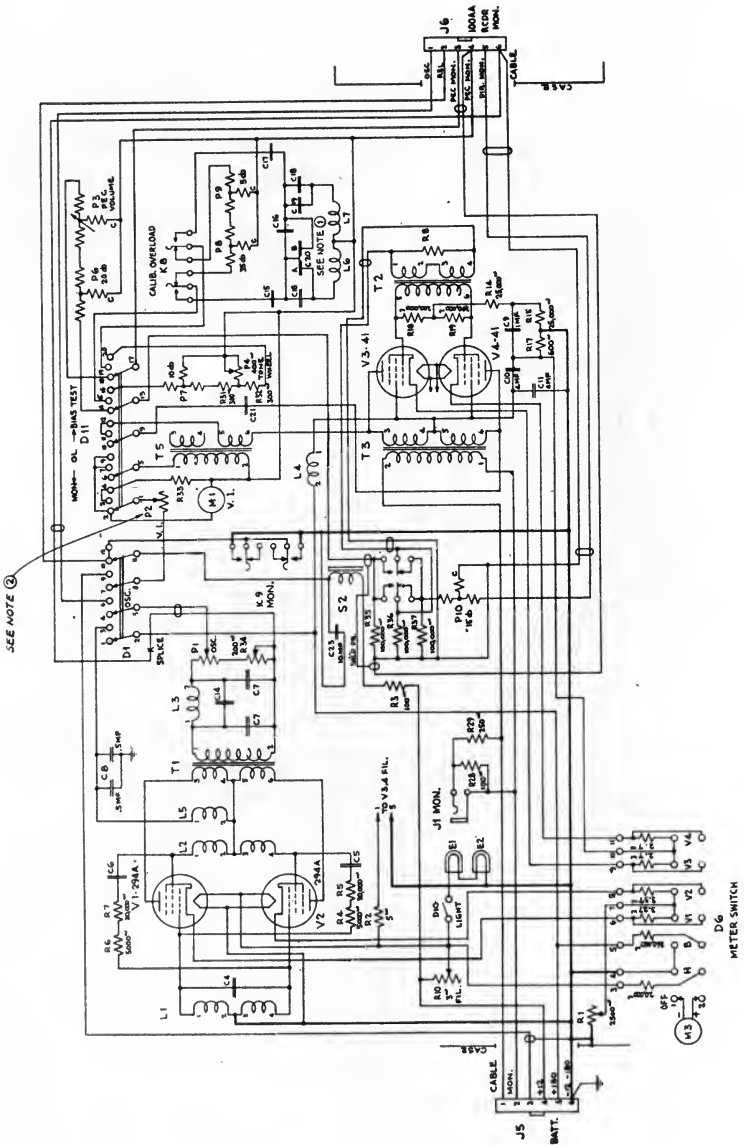

Fig. 10. Western Electric RA1004A recorder control.

The data given in Fig. 9 were obtained from an actual circuit as used for lineup in the system described. It has been found that unbalance in the photocell circuits within the limits of the balancing potentiometer affects the output of the even harmonics only to the

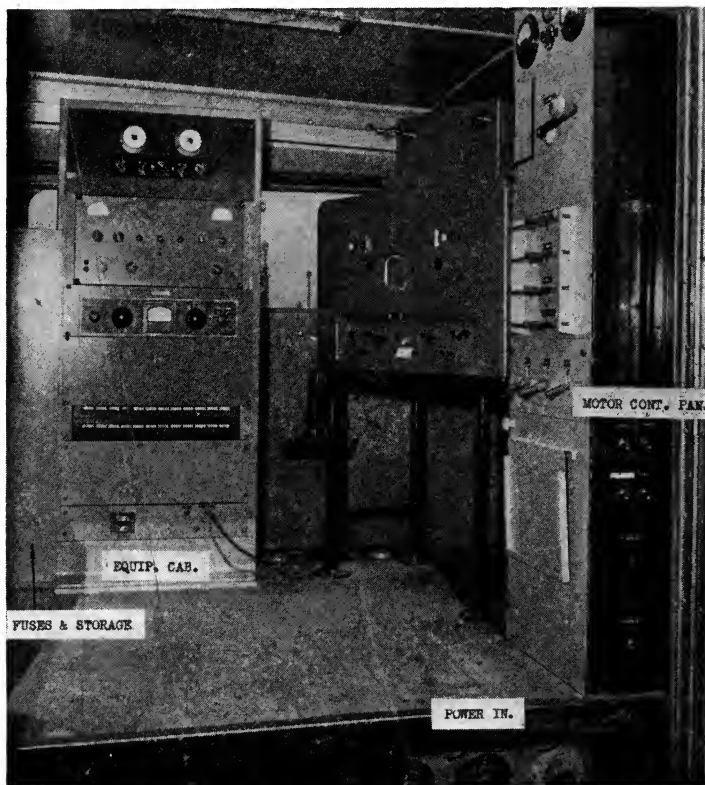

FIG. 11. Interior of operating compartment.

extent that the measured clash level is changed by 0.1 db. This method has the great advantage that inexperienced operators obtain the same result under given conditions.

Fig. 8C shows the condition obtained on the third position of the lineup switches. This circuit provides a means to measure the level applied to the valve, and also to set the noise-reduction margin. When the oscillator switch is operated to the "off" position, the re-

maining condition is that required for normal monitoring operation.

Fig. 10 gives the complete circuit of the control cabinet, showing the switching arrangement to accomplish the above described lineup

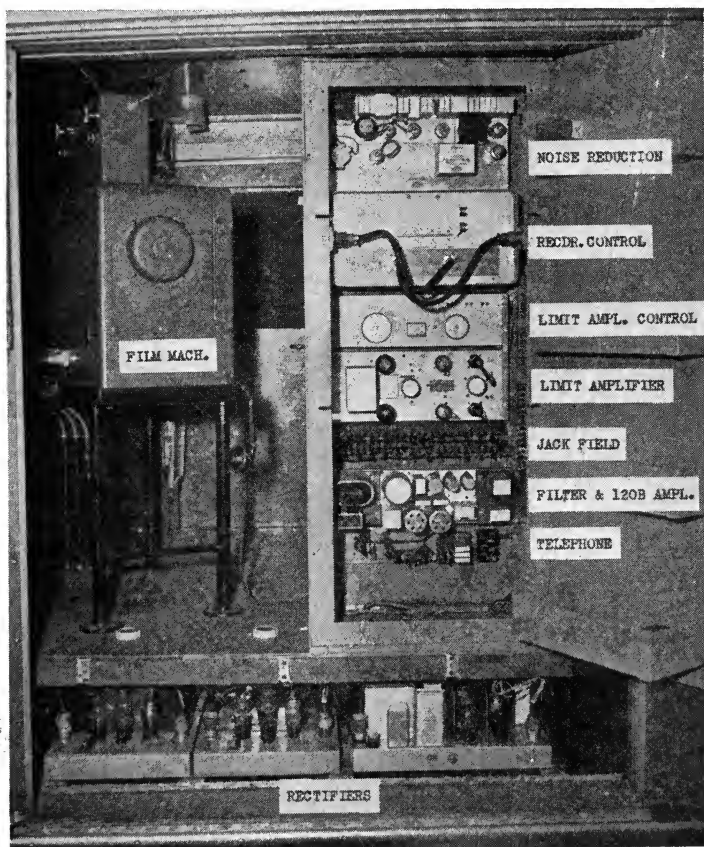

FIG. 12. Rear view of equipment cabinet, showing power supplies.

operation, the associated output amplifier, the oscillator, monitoring relay, and associated circuits.

Adjustment of the limiting point of the *RA1166*, with respect to valve clash, is accomplished by patching the oscillator to the input of the *RA1166* and operating the light-valve key to the "record" position, which provides a volume indicator across the valve input.

The oscillator output is then adjusted to the limit point of the amplifier and the output pad adjusted to give the desired valve level.

The noise-reduction unit is an *RA1124* which is of the modulated oscillator type having peak reading characteristics and facilities for reverse bias and margin threshold adjustment. The oscillator circuit used is of the resistance-capacitance type and therefore very stable in frequency. In the original design¹¹ the oscillator output voltage was stabilized by means of a thermistor connected in the frequency determining network. Since a truck-mounted unit is subjected to wide changes in temperature, it was necessary to remove the thermistor because the output was adversely affected by these variations. Since regulated power supplies are used, the oscillator stability is main-



FIG. 13. Portable recording unit.

tained sufficiently well for the conditions of use, and the increase in oscillator output, occasioned by the removal of the thermistor, is compensated by shunting down the output.

MECHANICAL LAYOUT

The layout does not require much description, being very evident in Figs. 11 and 12. The factors primarily influencing the layout in the truck were: (a) use of existing truck and body; (b) use without modification of existing motor system and control cabinet; (c) accessibility for operation and maintenance. Manifestly, the only item where considerable latitude in design layout could be exercised was the last.

All of the speech equipment, except that incorporated as part of the recorder, is mounted in an upright cabinet; the choice of eye-level

location being given to those equipments most frequently used. Since the jack field is supplied mostly for test purposes, it was assigned a much lower position than is customary. From the top to bottom in the equipment cabinet we find: the noise-reduction unit, recorder control cabinet, *RA1166* control panel, *RA1166* amplifier proper behind the blank panel, jack field, *120B* amplifier and filters behind a blank panel, and the telephone panel. The back door of the cabinet provides access to all tubes and the majority of the wiring, and additionally serves as a storage space for tubes, *etc.*

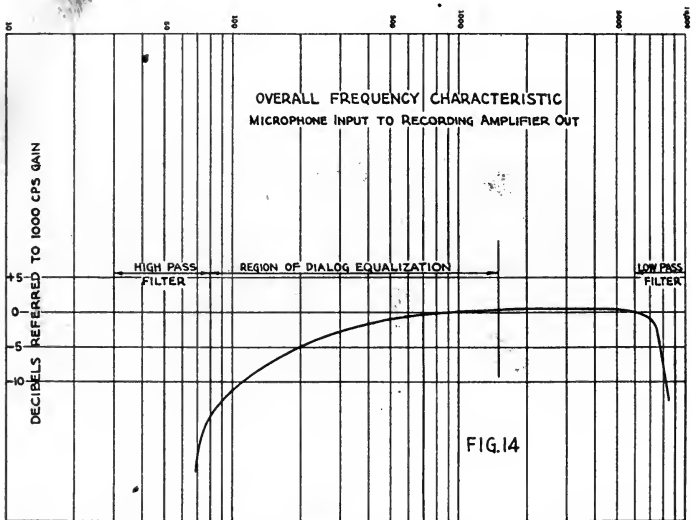

FIG. 14. Over-all frequency characteristic.

All speech power supply circuits are fused, as is the usual practice, but these fuses are grouped together in a single location convenient to the operator behind the small vertical door on the extreme left of Fig. 11.

High-voltage power supplies are mounted in a space under the body floor and behind the running board, as shown in Fig. 12. These are readily accessible by removing a metal cover, and can be quickly replaced because they are provided with input and output plugs. All supplies are of the regulated type.

Fig. 13 shows a general view of the truck housing the complete recording unit.

SYSTEM CHARACTERISTICS

The various characteristics are shown in Figs. 14, 15, and 16; the last showing clearly the expected film processing latitude owing

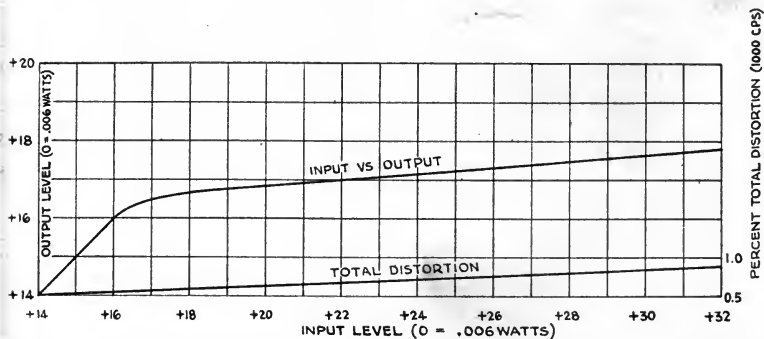

FIG. 15. Input-output and distortion characteristics; microphone input to low-pass filter output.

to the push-pull track, and that 60-1000 cps intermodulation lower than 3 per cent can be readily achieved.

CONCLUSIONS

One recording system of the type herewith described has been in service approximately 5 months. During this period no major faults

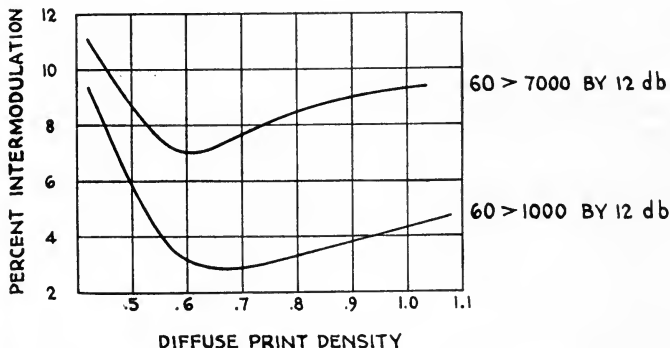

FIG. 16. 200-mil push-pull film and modulator intermodulation, 3 db below unbiased overload.

have developed and minor troubles have been very few. Track balance is very easily maintained, as indicated by the fact that negative noise-reduction computations, based on biased-unbiased strips, have

not varied more than ± 0.25 db. Light-valve stability is evidenced by variations in clash level of ± 0.5 db including temperature effects, spacing changes, and lineup discrepancies. Recording fidelity has been equally satisfactory; an improvement in release product being evident even though the original record is re-recorded to single track. For ordinary purposes of editing, *etc.*, a single track is reproduced which also shows an improvement in quality over the presently used system, although depending upon the character of the recorded material, the effects of the higher noise-reduction operating timing are sometimes evident.

REFERENCES

- ¹ GOLDSMITH, L. T., AND RYAN, B. F.: "A Mobile Sound Recording Channel," *J. Soc. Mot. Pict. Eng.*, **XXX** (Feb., 1938), p. 219.
- ² RALPH, C. M., AND MATTHEWS, J. G.: "New Ideas in Mobile Sound Recording Equipment," *J. Soc. Mot. Pict. Eng.*, **XXX** (May, 1938), p. 577.
- ³ KREUZER, B., AND LOOTENS, C. L.: "A New Mobile Film Recording System," *J. Soc. Mot. Pict. Eng.*, **XXXIII** (Oct., 1939), p. 315.
- ⁴ HOPPER, F. L., MANDERFELD, E. C., AND SCOVILLE, R. R.: "A Light-Weight Sound Recording System," *J. Soc. Mot. Pict. Eng.*, **XXXIII** (Oct., 1939), p. 449.
- ⁵ FAULKNER, C. W., AND BATSEL, C. N.: "Operation of the Variable-Intensity Recording System," *J. Soc. Mot. Pict. Eng.*, **XXXVI** (Feb., 1941), p. 125.
- ⁶ HILLIARD, J. K.: "The Variable-Density Film Recording System Used at MGM Studios," *J. Soc. Mot. Pict. Eng.*, **XL** (March, 1943), p. 143.
- ⁷ BLACK, W. L., AND NORMAN, N. C.: "Program-Operated Level-Governing Amplifier," *Proc. I. R. E.*, **29**, 11 (Nov., 1941), p. 573.
- ⁸ PFANNENSTIEHL, H.: "A High-Precision Sound-Film Recording Machine," *J. Soc. Mot. Pict. Eng.*, **XXIX** (Aug., 1937), p. 202.
- ⁹ MILLER, W. C.: "The MGM Recorder and Reproducer Equipment Units," *J. Soc. Mot. Pict. Eng.*, **XL** (May, 1943), p. 301.
- ¹⁰ DUPY, O. L., AND HILLIARD, J. K.: "A Monochromatic Variable-Density Recording System," *J. Soc. Mot. Pict. Eng.*, **XXXVI** (Apr. 1941), p. 366.
- ¹¹ SCOVILLE, R. R., AND BELL, W. L.: "Design and Use of Noise-Reduction Bias Systems," *J. Soc. Mot. Pict. Eng.*, **XXXVIII** (Feb., 1942), p. 125.

WARTIME CATALOGING OF MOTION PICTURE FILM*

JOHN G. BRADLEY**

Summary.—The problems and techniques concerned with locating scenes and other data in motion picture films after they have been deposited in the vaults of The National Archives in Washington are discussed and illustrated. The method is divided into two considerations: work which under the present man-power crisis must be done quickly, and work which may reasonably be postponed. The technique involves a "reference summary" which supplies the headline of the story and pertinent information, both of which may be read with a glance by the searcher.

A subject index card is another finding medium described. Compiled directly from the reference summary, the index card lists particular subjects found in a particular film, and gives the film's call or reference number.

Experimental work is being done at The National Archives on still another finding tool called a "reference film strip." Consisting of one frame for each title and for each important scene or subject, printed in sequence, it permits the searcher to see photographically the contents of the motion picture involved. The emphasis which this paper intends, however, is in behalf of the reference summary and the subject index file which should be created first to provide the searcher with the essential facts of his quest.

"Like finding a needle in a haystack" is a phrase known to everyone, and describes an experience which has been universally suffered. In the first place, it infers that there is a needle of immediate interest and a haystack of secondary interest. The crux of the matter becomes apparent, however, when the relationship of the needle and the hay is considered; for example, there is a lot of hay and only one needle. The individual straws, composing the hay, are comparable in general appearance to the needle, which makes the finding problem the more difficult. If the object sought were a wheelbarrow or some other dissimilar object, or if there were a blue thread leading from the outside of the haystack to the needle, no particular problem would prevail. The problem becomes acute when the search

* Presented May 5, 1943, at the Technical Conference in New York.

** Chief, Division of Motion Pictures and Sound Recordings, The National Archives, Washington, D. C.

involves a particular item hidden without clue among similar or reasonably similar objects, and when the items not wanted greatly outnumber the items wanted.

This homely illustration can be applied to the finding problem involving motion pictures; the particular subject or reel or scene wanted at the moment representing the needle, and all the rest of the collection representing the hay. That there is a lot of film and that it is accumulating at a staggering rate, needs little proof. That a particular film may be wanted quickly, needs still less proof. Added to this circumstance is the current pressure of work which frequently prevents a searcher from seeing a film or even reading a review. Time, like pork and beans, has been rationed. The luxury of leisure is out for the duration. The train is too slow; take an airplane. There is little time to read a 5-page scene-by-scene script; a synopsis must serve. There is little time to view a full release; a 5-min scanning of the best scene must suffice. And frequently the searcher will hesitate to leave his desk even for 5 min to scan a selected scene without proof that it is the scene he wants. This is something like saying, I haven't time to eat spinach; give me a vitamin pill. In brief, a busy executive must be provided with some easy means of determining quickly whether or not he wants to see a particular film or scene. This is the supreme test of a wartime finding medium.

No attempt will be made in this paper to explore the characteristics of the various finding mediums used in archival and library science such as guides, handbooks, checklists, inventories, calendars, and so forth. For the most part the discussion will be limited to a few forms and techniques which appear to have a special application to the problem under consideration. It should be stated, however, that a national survey of the problem has been made among various institutions handling motion picture films, and that this survey has contributed substantially to the plan which will be outlined shortly. Among those surveyed were producers, exchanges, universities, state departments of education, libraries, museums, and government agencies.

The discussion, thus limited, may be divided into two considerations: work which, under the present man-power crisis, must be done quickly, and work which may reasonably be postponed. This means that the principle of priority is recognized and that first things must come first; all others must take their turn. In other words, the searcher must be provided with the blue thread which will lead him

to the needle or a headline which will give him the gist of the story. After that is done, and time permitting, other help may be given.

REFERENCE SUMMARIES

In respect to work which must be done quickly, the first form to be considered is called a "reference summary," having its principal application to edited subjects. This is the *headline* of the story; reading time measured in seconds. In a non-technical sense this summary could be called a "catalog card" for the reason that it serves many cataloging functions. It differs from a detailed review or script, first, in that it takes less time to prepare, and second, in that it takes less time to read. In the proposed summary all unnecessary identification and documentation of objects, places, and persons (including the third man from the left) are omitted. Scene footage is left out. No attempt is made to anticipate all the future needs of all searchers; such work being postponed until an actual need arises. The language used is limited strictly to generic English, almost telegraphic in form; for example, it would defeat the purpose of this form if architectural language were used to describe buildings or if technical language were used to describe scientific gadgetry. Short of a large staff trained in specialized activities and vocabularies, the use of such language would be unsatisfactory to the expert. The expert, *when he sees the film*, can better determine than can members of any general staff whether, for example, a particular building is Tudor, Byzantine, or Gothic, or whether a particular gadget is a voltmeter, a by-pass condenser, or a screen grid. It is repeated, therefore, that the test of the proposed summary is to provide means by which a busy person can determine quickly whether or not he wants to leave his desk and see a particular film.

With such a test in mind the following typical summary is presented for further consideration:

TITLE: RETREAT OF THE GERMANS AT THE BATTLE OF ARRAS

230 H-1108

DESCRIPTION: Factual 7 reel b&w 35mm silent 64 minutes

CREDITS: Produced by the U. S. Signal Corps in 1918. Source: same

SYNOPSIS: Retreating Germans blow up bridges and roads. Howitzers and other field pieces in action. Engineers repair bridges and roads. British Tommy reads latest war news to villagers and is received with enthusiasm. Pipes and Drums of the Gordons celebrate. Units participating: Northamptonshire Regiment, South Africans, Hussars, London Stock Exchange Battalion,

King's Liverpools and King's Own Shropshire Light Infantry, Royal West Kents, Middlesex Battalion, Queenlanders, Tasmanians, and members of the 29th Infantry. Cyclist patrol, artillery, infantry, and cavalry. Places: River Somme, River Scarpe, and the villages of Arras, Roye, and Monchy. Personages: Raymond Poincare, President of France.

CUSTODIAN: The National Archives. Ac596

SERVICE STATUS: Inquire of above for details

REVIEWED BY: John Doe, June 18, 1935

An examination of the foregoing form will reveal some of the considerations which led to its adoption. In the first place it utilizes a standard 5 X 8-in. card for which standard filing equipment exists. It is limited to 7 subheadings, listed in "caps" at the left. With the exception of the call number (230 H-1108) there is only one margin to contend with, requiring a minimum shifting of the typewriter carriage. Punctuation is used sparingly. Underscoring is omitted. The language is simple. The scanning time is approximately 30 sec. Yet it is believed that this summary gives all the essential information for the purposes advocated; for example, it gives the title as a basis for an alphabetical file, a call number as a basis for a numerical file, and production credits by means of which a source file can be established if wanted.

Under the caption *DESCRIPTION*, all essential technical data are given: length, size, color, and a statement whether it is silent or synchronized with sound. However, the physical condition of the film and its form (negative, master positive, or projection print) are not revealed. Such information is omitted for the reason that it may vary from day to day, and is not considered essential in terms of subject-matter interests. Thus the custodian might have only a negative at the time the review was made, but would have a projection print a few days later. Such variable information is kept on another form and can be determined when necessary.

Under *CREDITS*, information is given covering the name of the producer, the date of the production, and the source from which the film was transferred.

The *SYNOPSIS* appears self-explanatory; however, it should be noted in passing that it lists several items which may be indexed in a subject-matter file later if circumstances warrant.

Under the caption *CUSTODIAN*, is given the name of the agency having immediate charge of the film under consideration. Such an

agency generally enjoys preservation, reference, and distribution responsibilities, but not necessarily all of these. Any deviation from such responsibility is clarified under the caption *SERVICE STATUS* which immediately follows. Frequently film in the custody of one agency is copyrighted by another. Again, a given film may be deposited under restrictions such as *confidential* or *secret*, or limited to a particular type of audience. There are many current military films which are so restricted. All such limitations are listed.

The caption *REVIEWED BY* serves to fix the responsibility for the information given and indicates the time the review was made; the merit of this seems obvious.

It will be noted that in addition to the call number (*230 H-1108*), which locates a particular film in a particular storage vault, the number *Ac596* is given following the name of the custodian. This is a key number which serves to connect the summary to the administrative history of the film summarized. It has little interest to anyone except the custodian. Other key numbers may be added from time to time if necessary, and each custodian may create his own key numbers in terms of his particular needs.

Finally, it should be noted that each card is made up individually and is thus freed from the limitations of predetermined spacing which a printed form would impose. The need for such expansibility is based on the variation in the films reviewed; for example, one subject might require only one line for credits while another subject might require 3 or 4 lines. The length of the synopses will certainly depend on the number of reels involved and the meatiness of the information they contain. A clear statement on the service status of the item might require one or several lines. The application of the form in terms of variations is illustrated by additional summaries, excerpts from which are given below.

TITLE: THE PLOW THAT BROKE THE PLAINS

94 2

DESCRIPTION: Factual-Expository....

CREDITS: Produced by Farm Security Administration in 1930. Direction, Pare Lorenz. Music, Virgil Thompson. Research, Arch Mercey. Photography, Stacy and Howard Woodward. Source: United States Film Service.

SYNOPSIS:

CUSTODIAN: The National Archives

SERVICE STATUS: Distributed by the Department of Agriculture

Three variations will be noted in this summary as compared with the one cited before: the first variation appears after the caption *DESCRIPTION* which describes the film as "Factual-Expository" rather than "Factual." *CREDITS* uses 4 lines instead of one as before, and the transfer credit differs from the production credit. Finally, it will be noted that the distributor differs from the custodian.

TITLE: KILL OR BE KILLED TF21-1024
 DESCRIPTION: Factual-Expository training film . . .
 CREDITS:
 SYNOPSIS:
 CUSTODIAN: The National Archives
 SERVICE STATUS: Restricted to military personnel

Two variations are noted here: it is a training film, and military restrictions are imposed.

TITLE: THE DECLARATION OF INDEPENDENCE 114 2
 DESCRIPTION: Re-creation 2 reels Technicolor . . .
 CREDITS:
 SYNOPSIS: A dramatization of . . .
 SERVICE STATUS: Copyrighted by Warner Brothers Pictures. May be consulted on reference basis with permission of custodian.

Four variations are noted here: the picture represents a re-created or dramatized situation; it is in Technicolor; it is copyrighted; and *SERVICE STATUS* requires 2 lines.

Other variations will be encountered as different films are summarized, but these should offer no particular difficulty if ordinary judgment is exercised in the execution of the form.

The same format (though perhaps on a 4 X 6-in. card) may be used to advantage for unedited footage, cut-outs, and library shots. Certainly the entering of a descriptive title or general subject would be helpful; technical information covering such items as size, color, length, *etc.*, seems necessary; some form of synopsis should be included; a statement of credits is always in order; and data concerning copyright and other restrictions would be useful. In this connection it should be pointed out that certain government agencies

are considering the use of the so-called punch card or block techniques in handling unedited footage. The use of such techniques would require an entirely different format, and punch or block areas would have to be provided for each category of information to be considered.

SUBJECT INDEX CARDS

Another finding medium which should have high priority is a subject index card. As before, the present man-power problem dictates that such work be streamlined as much as possible both in terms of the reviewer's time and the searcher's time. Brevity, simplicity, clarity, and the postponement of all non-essential efforts should govern in the preparation of this form.

It is believed that such an index card can be compiled directly from the reference summary, completely by-passing the longer scene-by-scene reviews. This is possible if a statement of the exact footage of each scene can be postponed until an actual need arises, and if the indexer has primary knowledge of the film itself; that is, if he has seen it. However, a primary knowledge of the film is not always necessary for the reason that existing literature on certain motion pictures may prove entirely adequate.

A second examination of the reference summary entitled *RETREAT OF THE GERMANS AT THE BATTLE OF ARRAS* seems in order at this point. It will be noted that this summary includes a brief mention of certain subjects in which the indexer will be interested. Some of these subjects are: *bridges, howitzers, Royal West Kents, Tasmanians, the 29th Infantry, the river Somme, and Raymond Poincare*. In other words, the summary indicates that the film reviewed contained *some* information on these subjects, but just how much information and the footage devoted to each subject are not indicated. In brief a *clue* is supplied which will lead the searcher to the film itself if he is interested. The index card, therefore, would list a particular subject found in this particular film and give the film's call number. However, other films with other call numbers may contain material on the same subject in which case other references would be placed on the same index card so that such scattered information could be brought together at one focal point—the index card. Suppose, for example, the subject is *howitzers* and that this subject is found in several films in the same depository. Such a card would appear something like the following:

HOWITZERS

41 14	230 H-1108
41 32	230 H-1115
41 45	230 H-167
41 65	692 12
45 14	1673 20
74 1	1856 1
119 10	1856 13

In the above example (*Note: the numbers used are not necessarily valid*), the left part of each call number (*41, 119, 230, 1856, etc.*) represents a basic group or collection, while the right part of the number (*14, 32, H-1108, etc.*) represents a subject within a basic group. The group numbers at The National Archives are derived from a form called the "Receipt Invoice" and are assigned chronologically as different shipments are received. However, all related parts of a well-defined group or collection receive the same group number. Thus, *41* represents the Bureau of Mines collection, while *230* represents the Signal Corps collection, *etc.* A combination of the group number and the subject number results in the call number; thus *230* (group) plus *H-1108* (subject) equals *230 H-1108*, the call number.

The *H* is a symbol inherited from the Signal Corps. The perpetuation and use of numbers and symbols created by the agency of origin is generally considered good practice for the reason that it establishes a common denominator between the custodian and such agency or others who may have copies of the same film, or literature referring to the same film.

In brief, it should be noted that the subject index card is simple in form and easy to execute. It can be expanded with new entries as additional films are reviewed. On a 3 × 5-in. form some 20 references can be entered on the face of the card and an equal number on the reverse side. Additional cards can be added as needed. The listing of the titles of the films on this card might be an advantage, but the penalty paid in the additional time and paper required for such listing would probably offset the advantages gained. Such listing is not recommended during the present man-power shortage. However, this advantage may be realized by an alternative plan which deserves consideration. This involves processing each reference summary card in sufficient number so that it can be cross-indexed under each pertinent subject. This could be done by placing each

such subject (*howitzers*, for example) at the top of each summary card and filing the cards alphabetically. This would eliminate the necessity for the 3 × 5-in. subject index file card and would repeat the entire summary under each subject indexed. At least two important institutions are using a modification of such a plan with apparent success.

REFERENCE FILM STRIPS

Experimental work is being done at The National Archives on still another finding tool which holds out great promise, but which, for the present, must receive secondary consideration. This tool is called a "reference film strip" and consists of one frame for each title and for each important scene or subject, printed *in sequence*, as a projection positive from the film reviewed. Each frame so printed would correspond to textual entries made in the more lengthy and detailed scripts. It would permit the searcher to see photographically what he might otherwise read in the script, and, since one picture is supposed to be worth a thousand words, the advantages of such a strip can be easily seen. If, to refer to an illustration previously used, buildings represent the subject under consideration, then the architect can see instantly whether a particular building is a Tudor, Byzantine, or Gothic. It has the additional value of preventing wear and tear on the projection print, of saving the time of the searcher and the projectionist, and of freeing projection equipment for other purposes. Once a negative of a particular subject was processed additional prints could be made and distributed for reference purposes at a small cost. Such strips can be read on any conventional microfilm reading machine.

It should be noted that the footage of the different scenes is not given. No distinction is made between full scenes and montage flashes. This is postponable information which has already been mentioned in this discussion; neither does this strip reproduce sound for obvious reasons. It has other limitations some of which may be overcome; for example, the strip camera might include a device which would place a simple numeral on each scene represented, to indicate its length, *etc.* However, the virtues of the plan are so pronounced that further study seems entirely justifiable, and it is mentioned in this paper in an effort to solicit the cooperation of others in its development.

SCENE-BY-SCENE REVIEWS

There seems to be little question that a scene-by-scene review or script is fundamentally sound. In such a review not only can the footage of each scene be given but the nature of the camera shot can be recorded, such as a close-up, long-shot, medium-shot, *etc.* Furthermore, such a review would provide a basis for a scene index file with a frame from each scene included. However, such work represents a luxury which few can afford at the present time regardless of its merit. Certainly this statement would seem to apply to routine material when the collections are large. This would not preclude the making of such a review when an actual need arose, nor perhaps a modification of a shooting script into such a review when such scripts are available. For The National Archives, however, where the film itself is generally the total source of information, such reviews are out of the question at the moment and must be postponed until better times in terms of man-power and film stock prevail.

SUMMARY

The emphasis which this paper intends is in behalf of the reference summary and the subject index file. It is believed that these two finding mediums should be created first and quickly. Under such a procedure the finding tools could reasonably keep pace with production schedules and some means would be provided for leading the searcher, fortified with some knowledge, to the film itself. The advisability of issuing additional finding mediums is a matter for each custodian to determine, the availability of personnel being the principal consideration.

MOTION PICTURE INCUNABULA IN THE LIBRARY OF CONGRESS*

HOWARD L. WALLS**

Summary.—A brief survey of the importance of the motion picture and its preservation as an outstanding part of the Nation's culture; summary of the various ways in which early films were lost, destroyed or left to decay; an analysis of recent attempts by various individuals and organizations (public and private) to minimize this significant loss to motion picture art by the rescue of remaining films, and an account of their difficulties arising from the great scarcity of early film material.

A narration of how the early film companies (Edison, Biograph, and others) sent photographic paper tape of their films to The Library of Congress for copyright as photographs; how these paper prints were stored as copyright deposits from 1897 to 1915 in an almost continuous sequence; the recent discovery by The Library of Congress that these prints could be rephotographed through optical printing to celluloid, thereby restoring almost all of the early films to the screen in a single, comprehensive project.

The importance of this discovery from social, aesthetic, and historical viewpoints is discussed.

Of all the methods evolved by human ingenuity in the effort at self- and social expression, the medium of the motion picture appears capable of producing the most profound influence upon the society it reflects. This prominence is derived from an inherent, magic power of the motion picture to command an almost universal attention which allows it to transcend the purely aesthetic form and to assume, in addition, greater historical values. No phase of human existence is free from the graphic interpretation of the motion picture, and a medium of imaginative or social expression so all-inclusive places upon all of us the important responsibility of understanding that medium and the varied influences inevitably derived from its use.

The greater portion, if not all, of our appreciation and understanding of a social or art form must depend upon the opportunity given to us to explore, from the beginning, the developmental aspects or

* Presented May 5, 1943, at the Technical Conference in New York.

** In charge of Motion Picture Collections, The Library of Congress, Washington, D. C.

growth of that form. The wholesale disappearance of early motion pictures imposed serious disadvantages upon the students of the cinema, together with other interested scholars, and reduced our understanding of early cinematic achievements to a minimum.

Although the first producers of motion pictures had little faith in the future of their endeavors, or in the future of the motion picture as a permanent art form, it would be inconclusive to say that the disappearance of the early films is traceable to this factor alone. Along with this lack of cultural interest (unshared, of course, by all) are many extraneous factors which, in their entirety, greatly lessen the guilt: the lack of preservation methods for nitrate film, unintentional loss by fires and explosions, ultimate insolvency of striving producers, and frequent transfer of title rights to films are elements which must be considered in the chain of causes leading to general disappearance. In a few instances, where commercial reasons were strong enough, there were some efforts at preservation by producers and individual collectors, and this happy circumstance resulted in the survival of a few films which have provided the historian with at least something to seize upon in his attempt at interpretation. He has done well with the material at his disposal, but he has been denied access to the great body of early material which would have broadened his scope and placed him upon paths leading to greater truths.

With the growing recognition of the significance of the motion picture, a few individuals and organizations (both public and private) have launched recent attempts to collect and centralize early films. These enterprising attempts, aimed at film preservation for cultural or historical purposes, resulted in the collection of a small number of such films and simultaneously emphasized the great scarcity of early motion picture material. The combined efforts of these individuals and organizations disclosed that little more than 100 of the thousands of film subjects made between 1895 and 1912 had escaped destruction—and a great portion of these were in a deplorable condition.

It would appear from these facts that the case for the preservation of early films was lost forever, and, indeed, it would have been if it were not for a practice, almost miraculous in nature and extent, begun many years ago in The Library of Congress at Washington.

Prior to 1912, the Copyright Act contained no provision for the registration of motion pictures as such, and the early producers, beset with fears aroused by the common practice of pirating, or "duping," contrived an ingenious means of procuring copyright protection.

While a series of pictures on celluloid could not be copyrighted as motion pictures, they could, if printed on paper, be registered as photographs, and to all purposes receive the same protection that would have been granted by a more direct provision permitting the copyright of motion picture films.

This indirect method of obtaining copyright protection was inaugurated in 1897. After that time, and until 1912, each producer desiring such protection employed the practice of making two positive paper prints of each motion picture filmed, and submitted them to the United States Copyright Office as deposits for registration.

These prints may be more nearly described as photographic paper reels, and are, with this exception of being on paper, identical in appearance with celluloid reels. Stored as copyright deposits from the Edison, Biograph, Méliès, Lubin, and other early motion picture companies, they constitute an almost continuous, unbroken sequence of the motion pictures produced from 1897 to 1912, and a considerable number after 1912 to 1917. The collection, greatly comprehensive, contains in round figures the incredible total of 5000 motion picture subjects, covering approximately two and one-half million feet of paper film. The works range from kinoscope peep shows and early trick photography, through historical happenings of great importance and interest, to entertainment films which reveal, step by step, the development of basic motion picture technique as we know it today.

The inability to project this opaque paper film to the screen has, until now, prevented the use of it as a motion picture collection. While attempting to establish this important material as a motion picture collection, and thus give to it full research values, The Library of Congress recently considered the possibility that the paper prints might be transferable to celluloid. Initial investigations soon revealed that a project of this nature had no precedent. The search for an expert who could engineer the proposed idea led eventually to Mr. Carl Louis Gregory in the Division of Motion Pictures and Sound Recordings at The National Archives. Mr. Gregory, the "dean" of American cinematographers, and long an expert at optical printing, was optimistic from the beginning. Through the further coöperation of Mr. John G. Bradley, Chief of the Division, arrangements were made to proceed with tests to determine the validity of transfer. The story is no longer than that; Mr. Gregory's initial tests estab-

lished at once the success of the venture, and demonstrated that, through the process of transfer, each motion picture would be re-invested with all the newness it possessed at the time it was first exhibited.

With the ultimate restoration of this vast quantity of motion picture incunabula to the screen now made possible in a single, comprehensive project, we at The Library of Congress are confident that a new and great chapter has been added to motion picture lore. The achievement largely erases the earlier neglect at preservation and replaces the loss. For the first time, the complete and analytical history of the early motion picture may be written without resort to conjecture, and The Library of Congress is in a position to provide graphic and lifelike information concerning notable personages of the past, historical events, and the customs and mores of a bygone and captivating era.

RESURRECTION OF EARLY MOTION PICTURES*

CARL LOUIS GREGORY**

Summary.—In a very brief outline the writer relates some of the highlights of the history of the motion picture and makes a plea that the industry take a more active interest in its own archives and the remaining relics of its own development. The years have taken most of its stalwart pioneers and their records have been scattered by the winds of time.

Recently The Library of Congress, under the administration of Archibald MacLeish, realized that it had, tucked away in its old repositories, a priceless and almost complete collection of all the motion pictures made or exhibited in the United States from 1896 to 1912. This collection is printed on fragile ribbons of paper and can not be projected in its present form.

Howard L. Walls, in charge of Motion Picture Collections, The Library of Congress, brought samples of these paper films to John G. Bradley, Chief of the Division of Motion Pictures and Sound Recordings, The National Archives. A description is given of how a method was worked out and the task of converting these paper records back to modern standard motion picture films was begun.

The motion picture is older than you think. Believe it or not, the earliest motion pictures of which we have authentic records were animated cartoons drawn on a ribbon of paper and viewed in a toy called a "Zoetrope."

The Zoetrope was patented by W. G. Horner in 1833.¹ It was also called the "Wheel of Life" because the objects depicted appeared to move as if endowed with life. This instrument consisted of a hollow cylinder constructed to revolve on its axis. Around the upper portion of the vertically held cylinder were a number of equidistant vertical slots. A number of paper ribbons, each with an animated sequence printed on it, were supplied with the toy. They were similar to a paper photographic print of a short strip of animated cartoon negative except that the edges bore no perforations and the equidistant images were side by side along the strip instead of top to bottom as in the present-day film.

* Presented May 5, 1943, at the Technical Conference in New York.

** Division of Motion Pictures and Sound Recordings, The National Archives, Washington, D. C.

Each subject was the same length as the inner circumference of the cylinder, and the number of frames was the same as the number of slots in the cylinder. The strip of pictures was placed inside the bottom circumference of the cylindrical cup below the slots, with the picture series facing inwards. From the center of the bottom of the cup a short axis shaft was fixed and inserted in a hollow handle so that the cylindrical cap could be easily whirled about its axis. By looking into the cup through the slits as the cup whirled on its axis, the figures seen through the slots seemed to be in motion.

Only bits of repetitious motion, such as a horse galloping, a ball tossed and caught, a dog jumping, *etc.*, were suitable for this toy as the action repeated itself at each successive revolution of the cylinder.

The idea of pictures that moved with lifelike animation is, of course, far older than history.² There exist today, in prehistoric caves in France, crude drawings of long-extinct buffalo in which the cave-man artist endeavored to depict the motion of the running animal with multiple drawings of the animal's legs. Various ancient historians have mentioned devices which seem to indicate that many other attempts have been made to endow pictures with lifelike movements. Doubtless these were crude forms of optical projectors or *cameras obscuras*. This occupation of the human mind with the idea of pictures endowed with the attributes of life seems to stem from the inadequacy of language to transmit ideas and descriptions.

A concept of anything outside of one's previous experience can never be an accurate one. The Chinese proverb, "One picture is better than ten thousand words," is probably older than Kong-fu-tse, the Chinese philosopher. Actually our written language is an evolution from pictographs to ideographs, and from ideographs to symbols to alphabets.

Today we have almost completed the cycle back to the pictograph again. But today, with the aid of science, our pictographs are no longer voiceless ghosts, phantoms on a two-dimensional screen. Today the phantoms on a silver sheet can be endowed with the three-dimensional solidity and natural color of life;³ they speak and move about in a recreated world of nature and man's handicraft that lacks only the actual tactile sense of feeling hands and tasting tongue to distinguish it from reality. Even the nostrils may be betrayed by synthetic scents.

Most of us are much too preoccupied with the present to cast an

eye down the dimming retrospect of the early days of the industry.⁴ The Historical Committee of the Society of Motion Picture Engineers has never yet been able to instill much interest in the early records of its birth and adolescent growth. Perhaps only when we begin to sense that stalwarts of pioneering days are either gone or slipping silently away, do we realize too late that with them priceless relics and historic memories are *spurlos versenkt*.

Association in the early days with such men as Thomas A. Edison, Edwin S. Porter, W. Kennedy Laurie Dickson, C. Francis Jenkins, W. T. Rock, Albert E. Smith, Frank Cannuck, Jean A. LeRoy, W. V. D. Kelley, Frederick E. Ives, Eugene A. Lauste, Herman DeVry, Stuart Blackton, and a host of others of lesser renown, who have passed on to that destination from which no traveler ever returns, brings to mind that very few of the pioneers of the early days are still alive. Yet the spirit of these men still lives in the musty archives of the industry which they did so much to create.

Perhaps we as engineers with eyes focused on the sunrise horizon of tomorrow should not be expected to glance back along the paths over which we toiled to attain the present. Our lives are dedicated to rending the veils that obscure the future. Somewhere behind, perhaps too far behind, plod the patient historians, the studious archivists, the busy librarians, and the chroniclers of forgotten events.

Some of these pioneers of the early days of the industry are on the Honor Roll of our Society. We can not do less than honor our own who made possible our very existence.

Quite probably we are wiser to leave the chronicles of the industry to the archivist, the librarian, and the historian in the cloistered chambers of halls of records in libraries, universities and museums—yet the writer can not help but believe that the motion picture industry itself should foster and endow a historical museum and library embracing all the phases of the motion picture, both technical and cultural.

There are hundreds, possibly thousands, of small collections in the hands of motion picture fans, present or former employees of studios and motion picture theaters, in junk shops and family attics, in the homes of cine amateurs, and on the shelves of pawn shops. In addition to these small collections there are many libraries and museums that have surplus material for which they do not have exhibit space.

The National Museum, Smithsonian Institution, has probably the largest exhibit of motion picture cameras and machines in America,

but Dr. A. J. Olmstead, Curator of Photography, states that they have a far larger amount in storage because they do not have exhibit space to show it. Much of the material on exhibition has been contributed through the efforts of the Society of Motion Picture Engineers.



FIG. 1. Howard L. Walls of The Library of Congress holding one of the paper ribbons printed from an early motion picture negative.

Probably none of the numerous institutions which have motion picture collections are exclusively devoted to cinematography. Perhaps it is not the time, especially at this period of emergency, to speculate on an exclusive repository for the archives of the motion picture. The National Archives, which has a Division of Motion

Pictures and Sound Recordings, has limitations imposed by law in the Congressional Act by which it was created. These limitations are further restricted by the budget, lack of space, and many other considerations. Quite probably as time goes on many of these limitations and restrictions will be removed or expanded to meet the ever-increasing use of motion pictures by the Government. But the Government has a war on its hands and the march to victory is its first consideration. Meanwhile, the increased use of the motion picture for defense training has stimulated the interest of all Government agencies in the use of this medium for ever broader purposes.



FIG. 2. A close-up of a roll of motion pictures on a paper ribbon.

Howard L. Walls has told how this stimulated the Congressional Library⁵ to inspect more closely its own activities in a form of expression in which it had only been perfunctorily engaged. That perfunctory duty was the copyrighting of motion pictures and the posters, stills, periodicals, scripts, books, advertising, *etc.*, which are closely connected with the industry.

Among other things it found in its storage vaults were paper copies of practically all the films which the industry had produced from the '90's to 1912 when the copyright act was changed to include motion pictures on transparent film.

When Mr. Walls brought specimens of these paper films to The

National Archives and they were shown to us, it was realized at once that he had presented us with a fascinating problem. Some of the paper ribbons were perforated like film, but many of them had been printed by some continuous process on imperforate paper tape. It was obvious that none of these fragile paper ribbons could be run through any ordinary projector or printing machine and that, even

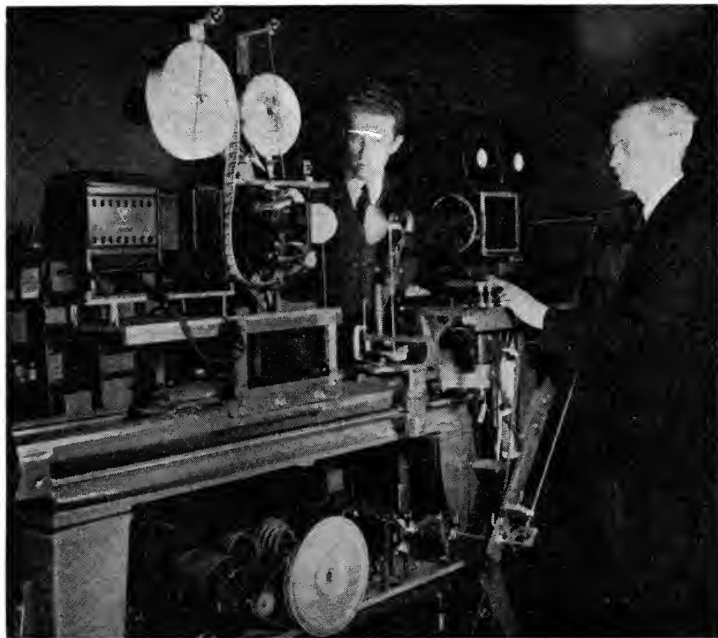

FIG. 3. A view of the process optical printer on which the paper motion picture prints were reproduced onto film. Left to right: Howard L. Walls, Carl Louis Gregory.

if they could be so run, they could not be projected on account of the opaque paper base.

In a previous paper read before the Society,⁶ the writer described a machine designed by him and constructed under his supervision for the reproduction of old and shrunken film which could not be reproduced on machines of modern standard design because the present machines would mutilate the smaller perforations or tear the fragile film; neither could the machine alter an off-standard frame

line nor reproduce all of the image in the frame, if space were masked off for the sound-track area.

A modified process optical printer was designed with a special projection head having interchangeable sprockets and pull-down pins to take without mutilation any old 35-mm film. An adjustable aperture plate permitted framing any off-standard frame lines. The camera head of the printer was provided with interchangeable aperture plates so that the old film could be reproduced to either silent or

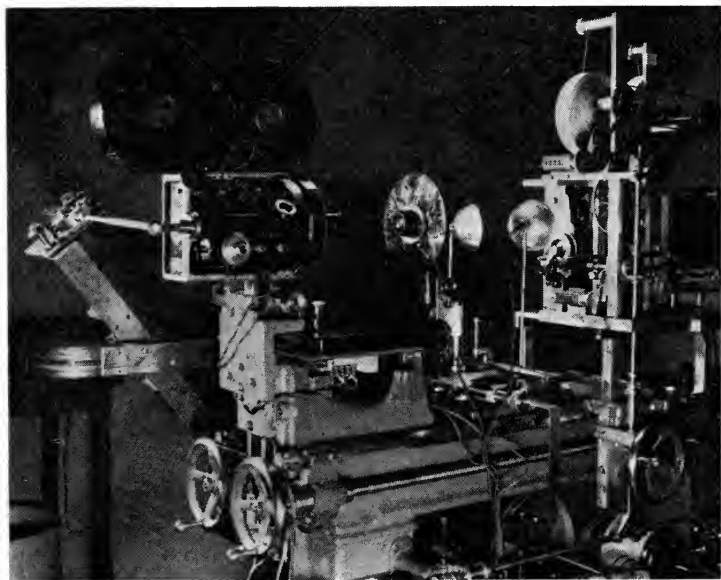

FIG. 4. Another view of the optical printer showing the opposite side.

sound standard. By means of a process lens between the projector head and the camera head, the image on the old film could be projected directly onto the modern standard reproducing film in the camera, either full size for silent standard or slightly reduced in size to fit the sound aperture.

In the latter case the camera is adjusted sideways just to the width of the sound-track area. By this method, commentary sound can be added to the track area, or the picture can be run on a sound projector without loss of that part of the image which would ordinarily be masked off by the sound-track. Also, by repeating the exposure of

each alternate frame, the silent speed of 16 frames per sec is altered to 24 per sec, thus obviating the jerky unnatural movement produced when a silent picture is run at sound speed.

When the writer examined the specimens of paper film brought by Mr. Walls, the resemblance of the fragile paper strips to that of old films was striking. Of course, the paper film could not be illuminated by transmitted light, but it could be photographed by reflected light. Why not, therefore, rig lights to illuminate its picture surface and copy it frame by frame on the process machine?

We tried it and found that it worked, although not without a great deal of trouble and many trials to obviate many difficulties of specular reflection and experimentation with lights, films, developers; and with only a very limited amount of time before the Conference to make samples and prepare these reports of the work which we did.

The results which we will show you are, of course, not yet as good as we hope to accomplish after further experimentation. It must also be borne in mind that the photography of the early days was far from being as good as that of today. Precision cameras were as yet unheard of, lenses were slow and uncorrected for the high magnification of projection, the film was very slow and coarse grained, tripods were shaky and panning devices very crude or not used at all. Exposures in sunlight were usually developed to soot shadows and whitewash high lights to give maximum contrast with oxy-hydrogen lime lights or spluttering coreless carbons, while pictures taken on cloudy or rainy days were regarded as excellent if you could recognize the features of a person close to the camera.

A few lantern slides have been prepared to show you just how these paper ribbons were copied onto film. As the paper is so fragile the machine has to operate at very slow speed—under the very best conditions not more than a frame or two could be copied per second. Working steadily and without taking into account preliminary test exposures and repairs to torn sprocket holes, it takes from 2½ to 5 or 6 hr at the machine to copy 1000 ft. When the copy negative is developed it is on standard film and can then be printed on conventional modern machines.

There is still much experimental work to be done to improve the process and to design and build special apparatus to handle the imperforate film which constitutes a large part of the collection.

Many of the paper films were also printed continuously without adjusting the printing time to the varying densities of the original

negative. This resulted in many scenes being printed either too light or too dark for successful copying by front illumination. Controlled methods of intensification of light scenes and reduction of dark scenes can probably be worked out so that these light and dark scenes will be suitable for copying.

It may also be possible to copy many darker scenes by giving a balanced exposure by both transmitted and reflected light. How-

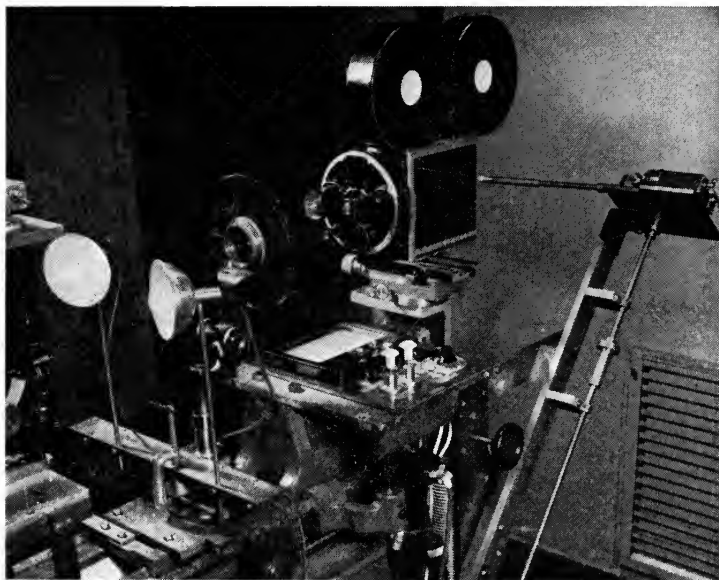

FIG. 5. A closer view of the "taking" head of the printer showing reflectors for surface illumination. The copying lens is in the center of the disk between the camera and the projector head. There is no lens in the camera as the copying lens forms the image direct on the film in the camera.

ever, preliminary tests showed that transmitted light, even with balancing front illumination, showed up the grain of the paper and would probably show up on the screen as a very coarse graininess. On account of the lack of time no conclusive tests could be carried through to be reported in this paper. Probably different thicknesses of paper will require different treatment, as some of the prints are on heavy paper while others are on thin paper having much less grain than the thicker paper.

There is also a possibility that the paper can be transparentized

by chemical treatment so that it can be illuminated by transmitted light, but this, too, requires extensive experimentation before any of these priceless graphic records can be subjected to such treatment.

Copying of imperforate ribbons is also a grave problem and presents two main alternatives: the first, and the easier of these, is to devise a gripper⁷ movement with feed and take-up rollers instead of a shuttle movement and sprocket wheels. Such movements were used in

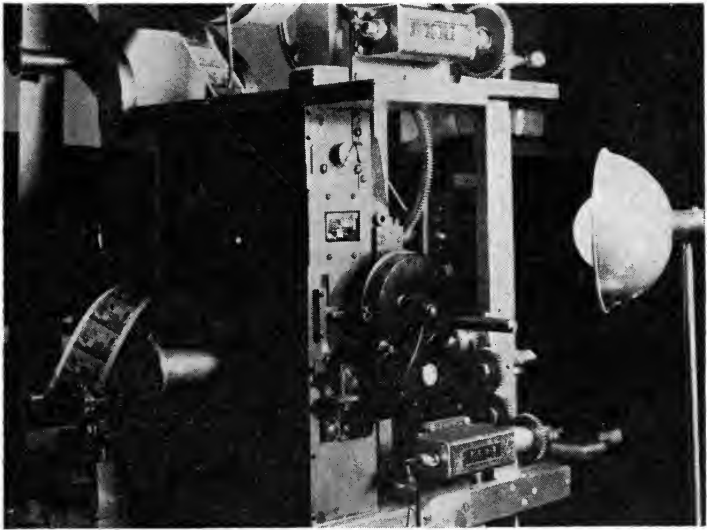

FIG. 6. A frame of the paper film shows in the aperture of the projecting head which is made from an old-type silent camera mechanism. Extraneous light is kept out by a long lens hood and a tube from the lens to the camera. These have been removed to show the mechanism more clearly.

some of the old coin-in-a-slot machines that used this type of mechanism to show movies on paper ribbon. The second alternative is to perforate each frame after registration in a frame registering device. This, of course, would be a long tedious process similar in method to that of animated cartoon photography, in which each animation cell and its background are registered by registering pins before the exposure of each individual frame. This is not an exact parallel for several reasons. A cartoon cell is many times the size of a motion picture frame and a difference of a few thousandths of an inch in the registration of a cartoon cell would probably not be detectable on the

screen, while the difference of the same magnitude in the registration of a motion picture frame the size of a postage stamp would be quite apparent on the screen. Registration of each frame, in the case of the paper film, would require an optical magnifying device in which at least two stationary image points could be registered by a micrometric adjusting device with two corresponding registration points on a reticule in the optical viewing instrument. As each frame came into registration perforating punches would operate and punch registration holes for each frame, after which the paper ribbon could be run in the optical printer projector head for copying.

This description may sound complicated, but it is in reality quite simple when compared to devices and processes which are in daily use in all the animation studios.

When one considers that by this means any or nearly all of the first motion pictures ever made—the priceless incunabula of a new graphic art, the living picture of a bygone age—can be restored for us and for the generations to come, it seems well worth the effort and expenditure.

REFERENCES

¹ GREGORY, C. L.: "Motion Picture Photography," *Falk Publishing Co.* (New York), 1927, p. 7.

² JONES, L. A.: "Presidential Address," *Trans. Soc. Mot. Pict. Eng.*, **XX** (Apr., 1925), p. 11.

³ NORLING, J. A.: "Three-Dimensional Motion Pictures," *J. Soc. Mot. Pict. Eng.*, **XXXIII** (Dec., 1939), p. 612.

⁴ RICHARDSON, F. H.: "What Happened in the Beginning," *Trans. Soc. Mot. Pict. Eng.*, **XXII** (Sept., 1925), p. 63.

⁵ WALLS, H. L.: "Motion Picture Incunabula in The Library of Congress," *J. Soc. Mot. Pict. Eng.*, **42**, 3 (Mar., 1944), p. 155.

⁶ GREGORY, C. L.: "Printers for Old and Shrunken Film," Report of the Committee on Preservation of Film, *J. Soc. Mot. Pict. Eng.*, **XXXV** (Dec., 1940), p. 599.

⁷ DICKSON, W. K. L.: "A Brief History of the Kinetoscope," *J. Soc. Mot. Pict. Eng.*, **XXI** (Dec., 1933), p. 435.

WALT DISNEY STUDIO—A WAR PLANT*

CARL NATER**

Summary.—The fact that many peace-time industries and manufacturing plants have been converted practically 100 per cent into war plants manufacturing implements for war, is a well-known, not unusual fact. However, when a cartoon studio, which for many years has been engaged in creating whimsical entertainment for the screen, suddenly becomes a war plant, it is a somewhat more unusual fact.

From a studio whose yearly production program included 2 or 3 features, plus 24 short subjects, Walt Disney Productions has at this time no feature in work, and is having difficulty producing a minimum number of short subjects. All of this, of course, is caused by the fact that between 90 and 95 per cent of the facilities of the organization are today devoted to producing training films for the Navy, the Army Signal Corps, the Army Air Forces, the Coordinator of Inter-American Affairs, the Treasury Department, and other governmental agencies.

This "change-over" in product at the Walt Disney Studio has brought a set of problems that is not frequently encountered in the average war plant. There was no radical "change-over" of heavy machinery, or the installation of new dies and presses. It was mental rather than physical adjustment.

A studio and its personnel accustomed to working for 2 or 3 years on one picture were suddenly requisitioned to produce a film, twice feature length, in 4 to 6 months. The financial departments accustomed to budgeting pictures for $\frac{3}{4}$ of a million to $1\frac{1}{2}$ million dollars found themselves piecing out \$12,000 and \$15,000, and less, for production budgets. Creative personnel accustomed to racking their brains for a new switch on some problem near and dear to Donald Duck's personality found themselves commissioned to explain to men at Navy training bases all aspects of the functioning and maintenance of a gyroscope, and its relation to the over-all functioning of an aerial torpedo.

To accomplish all of these ends, then, has been the task. That it has been accomplished is evidenced by the films now in use in all branches of the service. That the results have been worth while is indicated in several ways, but in no way more satisfying than when a man in uniform stops at the studio and states that he viewed such-and-such a picture in a combat zone and adds, ". . . it sure helped."

No reiteration is necessary that since the outbreak of the war this country has been synchronized into one great machine turning out the implements of war at an unparalleled pace. The secret of this pro-

* Presented Oct. 21, 1943, at the Technical Conference in Hollywood.

** Walt Disney Productions, Burbank, Calif.

duction lies, of course, in American ingenuity which has converted factories almost overnight from the manufacture of typewriters to the manufacture of machine guns, from thermostats to bomb sights, from automatic coal stokers to gun turrets and propeller hubs.

We feel that the conversion of Walt Disney's animation studio into a war plant is equally unusual and perhaps more surprising. For the greater part, the studio knew little other than the production of whimsical entertainment. Before December 7th, we were concerned chiefly with making Mickey Mouse cleverer, Donald Duck more captivating. Now it is our job to help simplify the mass production of men and implements for war. The home of Donald Duck has become not merely an essential war industry, but a bonafide "war plant" operating under Manning Table and Replacement Schedule plans as administered by the War Manpower Commission.

Before wartime production, the largest yearly output of the plant had been 37,000 ft of film. During the fiscal year, 1942 to 1943, Disney produced approximately 204,000 ft of film, which is $5\frac{1}{2}$ times the largest peace-time output. Of this amount 95 per cent came under governmental contracts. The balance, or approximately 10,000 ft, constituted the theatrical program produced for normal theater release. Included in the footage produced under governmental contracts were training films for the U. S. Navy, the Army Signal Corps, the Army Air Forces, the Air Transport Command, and other service branches. Films were also made for the Coordinator of Inter-American Affairs, the Treasury Department, and other agencies of the government.

It might be interesting to note that because much of this work involved live action or real photography, which was so closely related to the animation sections, it became advisable for Disney to do the entire job. At one time four companies were in action—one on our own live-action stage, two in the Middle West, and one in South America.

As the majority of these films were of a confidential nature, any detailed discussion of them is curtailed by certain security restrictions. However, this much can be said: the training films dealt very directly and very specifically with the important problem of overcoming the enemy once you meet him. How to shoot Jap or German fighters out of the sky; how to attack their bombers and their shipping, where and how to launch an aerial torpedo in order that it may sink an enemy ship; how to service, maintain, and use an automatic pilot

so that precision bombing can be accomplished—these are all typical examples of the subject matter incorporated in these training films.

In addition to this type of production which dealt with the direct methods of waging war, a series of pictures, less obvious in motive, was made for the Office of the Coordinator of Inter-American Affairs. The purpose of these films was to promote better understanding and relationship between North and South American allies.

As part of this program, several films dealing with agriculture and sanitation were made. These were designed to stress the importance of certain crops, to explain the proper method of protecting pure water supplies, to cite the merits of vaccination, and to assist in combating the *Anopheles* mosquito in the control of malaria fever.

In this malaria film, the seven dwarfs, Happy, Sleepy, Doc, and the others—even Dopey—portrayed in their own energetic manner the correct method of clearing a swamp to stop mosquito breeding. Other Disney characters, too, have found themselves useful on the home front. Donald Duck has periodically forgotten his own troubles to help Mr. Morgenthau clear up some of the misery we all experience around income tax time and to convince the American people that income taxes should be promptly paid. Minnie Mouse, with feminine understanding, endeavored to convince the housewife that the salvage of kitchen fats for ammunition glycerine uses was an important war job that could be performed in the kitchen.

However, adjusting Mickey Mouse and Donald Duck to their new roles involved almost every department of the studio, for the producing of educational and training films was, in effect, a completely new-type product and, like all war plants producing new products, there were many complications involved in the change-over, complications that perhaps paralleled the difficulties encountered when typewriters became machine guns and coal stokers, propeller hubs.

In many ways the problems were not serious, for no heavy machinery was involved, no dies or presses that needed redesigning, and there was no necessity for new installations. Regardless of the subject matter, the product was still shot on cameras and still produced on film.

Nevertheless, this change-over did bring with it many operational changes. Most drastic of these were time and cost. Before this type of work came to Disney's, it was not unusual for the studio to spend from 1 to 3 years producing a 6000-ft feature. To meet military schedules, it was necessary to produce a picture of equal

length in 2 to 3 months. From feature entertainment pictures costing from \$200 to \$250 per ft of completed film, it was necessary to produce a product costing as low, in some cases, as \$4.00 per completed ft.

This forced economy wrought the biggest problem encountered in the change-over, the problem of changing "mental equipment." The studio personnel had for many years been trained and admonished to adhere to a stringent quality standard. Upon this quality, Walt Disney feels his house of fantasy has been built. Since the birth of Mickey Mouse, it has been studio policy that quality must be the foremost consideration, even though this meant lengthening schedules and thus increasing costs. However, since December 7th, Disney studios has undergone a reevaluation of factors. Although quality is as much a part of training films as it is of theatrical films, wartime pressure has nevertheless forced it to ride in a "show" position behind price and schedule.

Another phase in this change-over of "mental equipment" was the problem of indoctrinating entertainment-experienced personnel into the ramifications of a new product requiring that emphasis be placed on teaching value rather than on entertainment value, although this in no way implies that training films must lack audience interest.

To swing the entire personnel to think in terms of teaching value rather than entertainment value might have been a simpler adjustment had not the item of footage cost been so important. When entertainment was the primary factor of the film, the artists were expected to take whatever time they needed to maintain Disney quality. To suddenly convince them that it was still necessary to maintain a certain standard of quality, but also to produce the picture in less than half the time, required not only the sincere efforts of everyone involved, but also an intelligent appreciation of the true balance between cost, time, and quality. It is apparent that the value of pictures dealing with the strategy of warfare lies in quick production. Training films would have little value if it took an impractical length of time to get them to their destination, for in this war any particular strategy is almost outmoded before it becomes practice. Therefore, it was the responsibility of the personnel working on these films to know when to temper quality for the sake of cost or schedule. Also, the ever-changing tactics and methods of warfare meant constant readjustments in each picture while it was in production. This, of course, is of little assistance in meeting a deadline.

Yes, becoming a war plant forced, in many departments, a com-

plete "about face." Fortunately, this was not true with all departments. The functions of some remained primarily the same. Included in this group might well be the Story Department. All scripts are prepared in a similar manner, and though training scripts demand more precision of thought—at the plant there was always the temptation to "gag" them up—primarily they require the same procedure as a cartoon, for they, too, just tell a story. Also in this group are the Inking and Painting Departments, the Camera Department, and Sound Recording Department. The work of these groups was accomplished in much the same manner as it had been during peacetime.

However, there were other departments which had to absorb the full weight of this new-type product. Our Layout Department, which actually designs the mechanics of the action to obtain the desired result, found itself dealing with difficult and highly mechanical problems. Small objects, such as planes and ships moving at a slow rate of speed on the screen, comprise one type of problem. This is usually encountered where diagrammatic presentation must be animated at an extremely low rate of speed. As you are generally aware, it is our production practice to carry each object that is animating on the screen on a separate level of celluloids superimposed one over the other on the camera table. In one particular instance a squadron of 12 torpedo planes was making passes at an enemy ship. Each plane was moving independently of the others, and it became necessary to make a separate camera exposure for each element in the scene—one for the ship, one for the wake of the ship, one for each plane, *etc.* On approximately 1000 ft of animation we shot 18 exposures for each scene thus actually increasing the shooting time for each scene some 18-fold plus the normal margin for error on retakes. We figured we had quite a headache.

Before our Camera Department began with each of their 18 exposure scenes, layout men had to design the camera operation. For men normally accustomed to planning and designing a Donald Duck dance or a Mickey Mouse piece of "business," this type of work called for considerable resourcefulness. Layout men, previously interested in the creative and artistic quality of a set or design—a "background," as we call them—suddenly found themselves using slide rules to figure out camera moves calibrated at times to $1/100$ in. Perhaps on these departments the greatest load has fallen.

The only group that runs a close second is, I believe, our Speci-

Effects Camera Department, for pure animation as drawn by the artist has its ultimate mechanical limitations, and it became necessary for our Special Effects Department to determine methods of achieving a marriage between real photography, animation photography, three-dimensional model work, and any other technique necessary to solve a given problem.

The studio personnel concerned with these particular problems have done a commendable job in devising new methods and sometimes unearthing old ones, cleverly renovated, to achieve a most acceptable photographic result. No better example of this is the use of cutout drawings. Twenty-five years ago, before the late Earl Hurd discovered and devised the now accepted use of celluloids in animation, it was the common practice to make drawings on a piece of paper, and then cut out the character in much the same way that a paper doll is cut out by a child. This cutout character and, of course, many others showing the character in different positions were then glued to the background before photography was made. The use of celluloids with its transparency permitted the elimination of this procedure and pushed the science of animation many years ahead.

Strangely enough, certain problems were thrown to our Special Effects Department on training films that were apparently insolvable through ordinary techniques. The final answer came in going back to the old cutout method. It is true that it was a modern version of this technique, but the principle was fundamentally the same. This occurred in various instances where the story continuity called for a small object, perhaps a plane, to come into view from infinity and slowly animate through a tactical maneuver, maintaining throughout precision movements simulating the actual flight attitudes of the plane. When such demands are made involving the animation of objects no larger than $\frac{1}{2}$ in. it is virtually impossible for an artist to make a series of drawings animating these movements, and then have the drawings traced and painted on celluloids without the final results appearing to jitter and shake on the screen. However, a small cutout plane the same size, animated by hand with the help of pantographs which eliminate the inking and painting function, can be moved, if the cameraman is steady enough that morning, in such a manner as to reduce jitter to a minimum.

We know that our experiences are perhaps no different from those encountered by thousands of other organizations which found themselves squeezed under wartime production pressure. Surely in all

plants where it was necessary to meet stringent and shortened deadlines, a method that required less time and less money was found. The accounts of our men and our machines on the battle fronts all over the world are, I believe, testimony to this assumption.

After victory is ours and the typewriter manufacturer again manufactures typewriters, and Walt Disney again turns to fantasy, we will all feel that the stress of the stringent schedules and budgets has forced us to know our own business better.

I am confident that the knowledge and experience gained by our studio from its part in the production of materials and trained fighting men for victory will bring not only improved cartoons for entertainment purposes, but will also stimulate a more extensive use of visual education in our post-war world.

AGRICULTURAL MOTION PICTURES AND THE WAR*

CHESTER A. LINDSTROM**

Summary.—Motion pictures, "just around the corner" for many years, have at last "come into their own." Although educators proved by numerous tests and studies that lessons, taught through the medium of motion pictures, were learned faster, retained longer, and were more thoroughly assimilated than by any other method of teaching, only industry had really recognized these facts and put them into action up to the start of the war. It took a world upheaval to break the inertia, and give motion pictures their rightful place in training programs.

In the agricultural field films are used to assist in the conversion of our agricultural production to the needs of total war. This, too, is a training job—the production of new and unfamiliar crops, efficient methods and short cuts to offset the lack of labor, good soil conservation practices, etc. Agricultural pictures are made also to assist in building and maintaining morale, to inform concerning war food conditions, and to promote definite agricultural programs. Industry has cooperated by producing pictures designed to help the war food situation. Foreign governments, notably the British and Canadian, have also produced and made available in the United States many pictures on the production and conservation of food. These agricultural pictures are bound to have a tremendous effect in the prosecution of the war.

For the second time since the birth of the motion picture industry, the screen has been called upon to fight side by side with other weapons in defense of our sacred liberties. And what a powerful weapon it is! It has been said that the pen is mightier than the sword. This new weapon is mightier than either. In the hands of a treacherous and unscrupulous enemy motion pictures spread fear and terror among the peoples of weak and defenseless countries, and made easier the conquests that followed. In our hands they are doing valiant service in ferreting out the activities and camouflage of our enemies, training our young army in the arts of war, cementing friendly relations with our neighbors and allies, guiding our war production effort, and maintaining morale on both the home and fighting fronts.

* Presented Oct. 22, 1943, at the Technical Conference in Hollywood.

** Associate Chief, Motion Picture Service, U. S. Department of Agriculture, Washington, D. C.

At no time have motion pictures been put to such varied uses as they are at present. Perhaps I may be excused for platitudinizing when I say that "motion pictures have *just* come into their own." We, who have been connected with their production and use for the past twenty-five years or more, have heard that statement made at probably every meeting where motion pictures have been a subject of discussion. Yet that "coming into their own" has always seemed to remain "just around the corner." By numerous studies and tests their value in education, instruction, and training was proved, yet a comparatively small portion of the school budgets went into motion pictures. It was left to industry to show by action instead of words that motion pictures had really been "recognized" as an educational and training medium. Before the war thousands of films were made by industry for sales promotion, public relations, and training purposes, and it is no credit to bigwig guardians of school budgets that for years these were practically the only motion pictures available to that earnest group of visually minded educators who saw in this medium the opening of a new field of unlimited possibilities in education and training.

It took a world upheaval to force acceptance of the proved facts that where appropriate motion pictures were used in teaching, lessons were learned faster, retained longer and were more thoroughly assimilated than by any other known method. Here we were, an unprepared nation faced with a fight for life, untrained, except for the small body of professional soldiers, in the skills by which wars are won. Ten million men unfamiliar with even the simplest implements of war, to be trained in the operation of rifles, machine guns, cannon, tanks; in communication, transportation and logistics, and in the thousands of other skills by which modern warfare is conducted. Additional millions had to be trained in the skills required for producing the complicated weapons of modern warfare. There was no time for the slow procedure of old-fashioned training methods. Time was on the side of the enemy. Each day saved meant the saving of perhaps thousands of lives, yet inadequate preparation might mean the loss of the war.

Necessity, therefore, forced the adoption of a medium which would train quickly and thoroughly not only a few, but thousands. This is where the motion picture "came into its own." Like an all-seeing eye it delved into the deepest mysteries of the interior workings of engines and guns and tanks, and brought forth, by animation and

stop motion, the secrets of construction and operation which had to be learned to operate them efficiently. Films were made to serve in every possible field of training. Instead of demonstrations that could be seen inadequately by just a few, training pictures were shown repeatedly to hundreds at a time, and training progressed more rapidly than even the most sanguine had hoped would be possible.

In the agricultural field, the problem was that of converting our peace-time production to the production of the foods, fibers, and oils needed for total war, guiding the food habits of a whole people to utilize available nutritive foods, and making an admittedly wasteful public conservation conscious. This, too, was a training job. Thirty-five million farm people can not be made to produce so many bushels of corn, peanuts, or soybeans by proclamation or regulation. They have to be shown the why and wherefore of conversion from crops that have proved profitable to some with which, possibly, they are unfamiliar, and they have to be shown how to grow the new crops. They want and need all the information they can get on the problems involved, in order to determine intelligently how to get the most of needed crops from their land with available machinery and man-hours. At no time has efficiency in farming been more necessary than at present. Many farmers, like the rest of us during years of peace, have slipped into ways of doing things that are not always the most efficient. They could get by with it then, but now the situation is different. There is less labor, less machinery, less fertilizer, less of everything. Efficient use of time means increased manpower; efficient methods of cultivating, fertilizing, feeding, harvesting, care and use of equipment mean not only the ability to increase production with less labor at a time when the latter is not readily obtainable, but to save all-important manpower while doing so.

The motion picture program of the Department of Agriculture, since the start of the war, has been geared largely to assist the farmer in solving such problems, and to give him information and guidance in converting and increasing his production to the needs of total war. Certain movies have been designed to build and maintain morale among the hard-pressed farm people, and, in the interest of harmony and coöperation, to give others an appreciation of what the farmers are doing to help win the war. Certain films have been of the how-to-do-it type; others have presented problems for consideration. The Department's war pictures for farmers may be classified into 3 main types:

(1) Guidance and incentive pictures, designed to encourage the production of adequate supplies of food, fiber, and oils to meet our war demands, and to stress the need for conservation of our resources.

(2) How-to-do-it pictures, designed to explain certain steps, processes or methods in agriculture, home economics, and forestry.

(3) Morale-building films.

The following are fair illustrations of the first or guidance and incentive type:

Wartime Farming in the Cornbelt, released in 1942, shows the steps taken to reclaim the soils depleted during and following World War I, and how in consequence the Cornbelt is now able to provide enormous quantities of food and fiber through the use of good soil conservation practices without unnecessary exploitation of the land. The conclusion plainly to be drawn is that good soil conservation practices increased yields, and that no sensible farmer would follow practices which deplete the soil and lead to ruin.

Democracy in Action, released shortly after Pearl Harbor, was rushed to completion before the spring planting season in order to impress farmers with the need for increasing production. It outlined the crop production goals to be reached during that first year.

Home on the Range was produced when the meat shortage was foreseen to show what the stockmen of the West were doing about it. It points the way to increased production through practices advocated in the government's range program, the realities of properly located water holes, windmills, watering tanks, deferred grazing, and contour farming.

Farm Battle Lines shows why it is essential for the South to produce more fats and oils; how the South can make a decided contribution to the war effort by producing more of the foods needed in the food-for-freedom program—milk, meat, eggs, vegetables—and that sound farming methods and conservation practices will help the farmer bring about these increases.

Live at Home is designed to encourage farmers to grow more food-stuff at home. It points out that no matter what happens, the farmer can live at home; a couple of cows, a litter of pigs, a flock of chickens, the orchard, the garden, will provide an abundance of milk, butter, eggs, meat, fruit, and vegetables. It further points out that living at home is not only profitable, but patriotic as well, for every pound of food produced for use at home releases that much for the men in our fighting forces.

In the how-to-do-it group are such films as the following:

The Farm Garden presents the fundamentals of garden husbandry, with particular reference to the farm garden and the national food emergency. It shows how to plan a garden, prepare the ground, when and how to plant the seeds, how to treat to prevent rot and blights; how to transplant, thin, cultivate; and to control pests and diseases, ending up with the rewards of good gardening.

Hemp for Victory tells how the war cut off our supply of East Indian coarse fibers, making it necessary for American farmers to supply the urgent needs of our Army and Navy, as well as civilians, with American grown hemp. Small amounts of hemp have been grown for years in Kentucky and Wisconsin, and the farm practices of these hemp growers are shown with the idea of encouraging farmers in other states to grow hemp to meet the war emergency.

Good examples of morale-building films are:

The Farmer's Wife—a documentary tribute to the farm women of America, and an explanation of their part in winning the war. It shows the farm wife accepting the increased work and responsibilities of wartime farming with a spirit that is an inspiration to young and old alike.

Henry Browne, Farmer, shows a representative Negro farm family doing its part in the agricultural war production program, while a son trains with the 99th Pursuit Squadron near Tuskegee, Alabama. Though made primarily for Negro audiences it is also popular with white people, and undoubtedly has made for fuller understanding between the races.

Several of our agricultural films, produced with Spanish narration, have been used to promote friendly relations with our Latin-American neighbors.

Democracy at Work in Rural Puerto Rico discusses the agricultural resources and problems of Puerto Rico. It shows how the rural people, under democratic guidance, are improving livestock, bettering farm and conservation practices, introducing new and developing old handicraft industries, and bettering the lot of farm youth through 4-H Club work.

Los Clubs 4-H en el Suelo de Coronado portrays the activities of Spanish-American 4-H Clubs in New Mexico and includes scenes illustrative of the agriculture of the American Southwest.

The foregoing types of films have been aimed primarily at the farmer. Others are designed to meet the needs of the public in general for information on the food situation. For instance, a film, *It's*

Up to You, goes into the why's and wherefore's of the point-rationing system and the evils of the black market in meats. *Canning the Victory Crop* shows in detail how to can fruits and vegetables, and *Dehydration* shows the advantages that have accrued through the development of the dehydration industry as a war measure, and what it means to our food economy of the future. Another film in production discusses the ways and means of storing the surplus from victory gardens for winter use.

The Department's own films are not made specifically for use in foreign countries. However, the Coordinator of Inter-American Affairs has reedited and translated a large number of our films into Spanish and Portuguese, and we are now about to begin production of 10 subjects for the State Department for issuance in Chinese. The Canadian and British governments have also duplicated our films for distribution in those countries. Sweden, South Africa, India, Egypt, and China also have acquired prints or duplicate negatives. In fact, without promotion of any kind, Department of Agriculture films have reached into practically every country in the world, the axis and occupied countries, of course having had access to them before the start of the war.

Our own Spanish-speaking population of the Southwest has not been forgotten. Many of these still use the language of their ancestors. To reach them in the language they understand best, several films in the Spanish dialect of the region have been made.

The Department of Agriculture, however, has not been alone in the production of films for the war food program. Britain and Canada have been wide awake to the need for motion pictures in informing their people concerning the food problems, and have produced numerous training and informative films that are now being circulated in this country. Among them are *Food—Weapon of Conquest*, which brings out clearly the importance of food in this war; *The Battle of the Harvest*, showing Britain's and Canada's food production efforts; *Mrs. T. and Her Cabbage Patch* and *Dig for Victory* on the planting and care of gardens; *Fighting Fields*, showing how Scotland had increased its yield from the soil; *Dinner at School, Miss T.*, and *Eating at Work* on diets and nutrition, and many how-to-do films on a variety of subjects, such as the care of poultry, clearing land, storing vegetables, rabbit raising and even how to spade up a garden. Such films have undoubtedly been of tremendous help in making the British Isles more nearly self-sufficient so far as food is concerned.

Industry, too, has taken a leading role in producing motion pictures to help solve the farm and food problems created by the war. Many excellent pictures have been made by industry, and it is noteworthy that most of them are devoid of advertising plugs that unfortunately in the past have made many otherwise excellent pictures unacceptable to many groups. I shall mention but 2 or 3 of them, not as best examples, but simply to illustrate how industry is cooperating in the war effort on the food front producing films on subject matter foreign to the business in which they are engaged. *Soldiers of the Soil*, a 3-reel film by the du Pont interests, is an excellent exposition of the reasons why farmers of draft age should remain on the farms until or unless they are inducted into the armed forces. Through the dramatic appeal of a blinded soldier, the young farmer is made to feel that he is engaged in the production of what our President has said is a decisive weapon of war, that his training and experience are needed on that production line, that he may hold his head high in the knowledge that he is truly a "soldier of the soil."

In the field of nutrition, the Westinghouse Company's film, *This Too Is Sabotage*, does a good job of selling the fact that a well-balanced diet is essential to health and happiness. This film is shown to employees in over a thousand war plants. The lunch hour is a favored time. Preshift showings to early arrivals are well attended, though many prefer to stay after a shift. The Ralston Purina Company has produced *Twenty Fighting Men*, an inspiring story of farm management and of the potentialities of increased livestock production through efficient feeding methods. Of course, this is for farm groups, and it is said to have worked wonders in the areas where it has been shown. None of these films contain advertising matter, simply the name of the company as the sponsor.

With the start of the war, the country was faced with the need of converting not only its industry but its agriculture to the needs of war. At no time in history had we been faced with such a stupendous task. In agriculture it meant that some 35 million farmers were to be stimulated to productive activity along planned lines. It was a job made to order for motion pictures. We planned plans and dreamed dreams of what could be done, if funds were made available with which to produce pictures to help create this vital weapon of food in ample kinds and quantities. But right here we had our first taste of priorities! Our studio and laboratory and 14 members of our production staff were taken over by the Coordinator of Information (now the Office of

Strategic Services) for more vital needs. This left the Motion Picture Service of the Department of Agriculture with a skeleton staff, inadequate production equipment, and no suitable working space. However, we did have some cameras, editing equipment, and trucks and with this as a nucleus we rented a building vacated by the Paramount Exchange in Washington and proceeded with our production from there.

All government work, of course, is dependent upon action by the Budget Bureau and Congress, and it was deemed necessary to reduce the appropriation for motion pictures of the Department of Agriculture. With the smallest appropriation in years we are striving to do an enormous wartime job. Our film activities of course have had to be reduced, and now the program of the oldest motion picture service in the government is a pigmy as compared with programs of the Army, Navy, and the Office of Education. However, we manage to produce about 20 pictures a year.

At present the Department's production staff consists of 11 directors, editors, cameramen, and technicians. This staff does necessary research work, writes scripts and scenarios, photographs, and edits the pictures. Sounding, optical work, cartoon, animation, and all laboratory work are done under contract. While not so satisfactory in some respects as having this work under immediate supervision under one roof, it has certain distinct advantages in that last-minute changes, which so frequently would hold up production, are not so easily made.

Our 30 years of experience have taught us the necessity of having script fully prepared and approved before production begins. We have worked out a procedure, therefore, that we endeavor to follow as far as practicable in every production. The first step is the preparation of a so-called Project Proposal, which is designed to bring out (1) the subject matter to be covered, (2) the purpose of the film—what it is hoped to accomplish, (3) the wartime significance of the subject, and (4) a synopsis of the treatment. When a film is proposed and sponsored by an agency of the Department, or where the film contains specific subject matter, the script is carefully reviewed by subject matter specialists and finally approved by the Director of Information of the Department before shooting is begun.

Most of the scenes for Department pictures are, of course, taken in the country, though urban activities are by no means out of the picture. It is surprising how agriculture touches the lives of all of us.

Our food, our clothing, and the houses we live in come from our farms and forests. So the problems of agriculture are not the problems of the farmers alone. They concern each and every one of us, for if the boll weevil destroys the cotton crop, we lack cloth, if the foot and mouth disease should destroy our cattle, steaks would be curios instead of rarities, and if we permit forest fires to destroy our trees, our lives would be handicapped from cradle to coffin.

But to return to our subject, a field photographic crew usually consists of 2 to 3 men, director, cameraman, and assistant. Where technical subjects are to be filmed, a specialist makes a fourth member and if sound on location is required, a sound crew of 2 men complete the crew. General locations are selected in advance, but it is up to the crew members to make detailed arrangements on the spot.

Shooting finished, the director with the assistance of the cameraman proceeds to edit the picture and complete the final script. Music may be furnished under contract or selected and arranged by our own staff. Recording may be done under contract or by our own sound-recording unit, depending upon where desired talent is located. The finished picture is then presented to various interested agencies for final approval. Usually, if the steps outlined above have been followed, acceptance is unanimous, but occasionally haste or some other element has permitted a false note to creep into the film. However, all these safeguards make it fairly certain that revisions, if necessary, will be minor and that the picture is a true, factual presentation of the subject covered. For incentive, morale-building, and certain other types of films where subject matter is not of first importance, the treatment varies, of course. Such films may be a combination of field and studio shots, acted and real life scenes, and cartoons.

Not all films are made by the Department's own staff. A production contract is entered into each year with some commercial producer as a result of bids. Last year 4 pictures were made under contract with Wilding Picture Productions, Inc., of Chicago.

Distribution of Department films is conducted principally through nontheatrical channels, the primary aim being to reach adult farm audiences. However, because of the wide application of many of the subjects covered, theatrical distribution also is obtained on some of the films. And, of course, prints are sold. Under contract with the Department, Castle Films handles these sales.

The nontheatrical distribution is conducted through various field

offices of the Department, the state extension services, and through some 50 film libraries of universities and colleges.

Theatrical distribution is cleared through the OWI.

The number of prints made available for distribution varies with the funds available. Usually, on films having general application, 100 16-mm prints have been placed in distribution.

In closing, I would like to say that motion pictures are doing a great deal to help agriculture in its war job. Judging by audience reaction, the millions who see these films most certainly are helped and informed and fortified in their determination to carry on, come hell or high water. Though the Department's own film activities have been limited by small appropriations, the British and Canadian governments and American industry have filled the breach to some extent. However, agriculture at war presents an unlimited field for training and instruction by motion pictures that not only will fashion a vital instrument of war, but will help to create a countryside where soil fertility is maintained by contour plowing and terracing; where sleek animals feed in lush pastures, where tree planting is restoring the water level in spring and stream, and wild creatures again have a chance for life; where winds no longer are permitted to carry away the top soil, and gullies are a thing of the past; where the water is clear and the air is pure; and where a farmer may be proud of his job. Such is the kind of America that agricultural films can and should help to fashion.

*Contribution from the Research Council, Academy of Motion Picture Arts and Sciences**

**REPORT OF THE BASIC SOUND COMMITTEE
ON
PRE- AND POST-EQUALIZATION FOR STUDIO USE****

FOREWORD

The Research Council's Basic Sound Committee has been giving consideration for quite some time to the possibility of standardizing on the characteristics of pre- and post-equalizers for **studio** use.

During this time, several of the studios employing variable density recording have been testing and using equalizers of different characteristics to the end that the improvement available in the signal-to-noise ratio has been well established. There has also been a trend toward establishing a uniform practice in regard to the total amount of equalization and the slope of the equalizer curve. Experimental work is still in progress at several of the studios.

At the present time, at least two different equalizers are in use in the studios, but through listening tests individual members of the Basic Sound Committee have determined that material recorded on either pre-equalizer will play satisfactorily on either post-equalizer. The characteristic herewith presented is in general use in those studios employing variable density recording.

Therefore, the Research Council, on the recommendation of the Basic Sound Committee, has adopted the attached curve as an Industry Practice rather than presenting it as a standard.

This Industry Practice has been adopted not only in the interest of standardization but also to aid in the interchange between studios of sound stock material and to provide proper post-equalization information for all recording studios.

Y. FRANK FREEMAN
Chairman, Research Council

December 15, 1943

* Taft Building, Hollywood.

** Technical Bulletin, 1943 Vol, December 15, 1943; released December 21, 1943.

REPORT OF THE BASIC SOUND COMMITTEE ON PRE- AND POST-EQUALIZATION FOR STUDIO USE

Ever since the advent of sound on film, there has been a recognized need for an increased volume range.

The range of recording has been limited by modulator and film overload at high volume levels and film and background noise at low volume levels.

Numerous systems have been proposed and are in use for obtaining an increased volume range. These include the modulator bias type of noise reduction as applied to standard width sound track, one hundred mil push-pull recording which permits increased noise reduction, two hundred mil push-pull recording, fine grain film, compressors, volume limiters, control track devices, and the herein proposed system of pre- and post-equalization.

Within the industry it has been found that each of the above systems has its advantages and limitations. Most of the studios are using several of these devices so as to gain a cascading advantage without reaching beyond the limits of good quality recording on any of the individual systems.

The name "Pre- and Post-Equalization" is a phrase, descriptive of the method used. A pre-equalizer which suppresses the low frequencies is inserted in the recording circuit between the microphone and the modulator. In reproducing these recordings, a complementary post-equalizer is inserted in the reproducing circuit between the photoelectric cell and the loudspeaker.

The objective in pre-equalizing is to gain a more advantageous energy distribution over the frequency spectrum to be recorded. In normal recordings, most of the objectionable noise occurs in the higher frequency range where the energy level of the desired signal is low as compared to the energy level of the lower frequencies. Thus the volume range of present recording is limited at the upper volume level by overloads caused largely by the high amplitude of low frequencies and at the lower volume level by objectionable noise blanketing the relatively low amplitude of high-frequency energy. The pre-equalizer suppresses the lower frequencies, thus higher percentage modulation of high frequencies may be attained before overload oc-

curs. The post-equalizer in the reproducing circuit returns the energy distribution to normal and in doing so attenuates the high frequencies and also the film noise, resulting in quieter recordings and increased volume range.

Pre- and post-equalization has the added advantage of reducing intermodulation distortion in recording. In general, the amount of intermodulation increases as the difference in amplitude of any two frequencies increases and intermodulation is most objectionable when occurring between a low frequency and the higher frequencies. Pre-equalization decreases the difference in amplitude between low and high frequencies and thus decreases the amount of objectionable intermodulation effects.

The amount of pre- and post-equalization which can be used in practice is limited to the point at which the increase in low frequency recorded and reproducer rumble becomes objectionable. The post-equalizer, which is complementary to the pre-equalizer, raises the low-frequency energy as compared to the high-frequency energy so any rumble or low-frequency disturbances are brought up in proportion to the amount of equalization used.

In the past, a form of pre-equalization has been taken advantage of, both from the peaks in the earlier type microphones and from high frequency modulator resonance. Many tests have been made using equalizers with different amounts of equalization and different equalizer slope characteristics.

From measurements reported by Sivian, Dunn, and White, information has been made available on the maximum intensity levels produced by both large and small orchestras. The average voice characteristics of both men and women have been determined by Loye and Morgan, from which an average peak level intensity can be derived.¹ These data show that peak energy occurs in dialog in the neighborhood of 500 to 700 cycles, whereas in the case of music the peak intensity takes place at a somewhat lower frequency. Since dialog represents a high percentage of material in a motion picture, the amount of pre-equalization that can be utilized to maintain this average load-factor throughout the spectrum must be determined.

Fletcher has used a similar form of pre-equalization for securing 10 db of noise reduction on the variable area stereophonic sound-on-film

RESEARCH COUNCIL INDUSTRY PRACTICE
PRE- AND POST-EQUALIZER CHARACTERISTICS

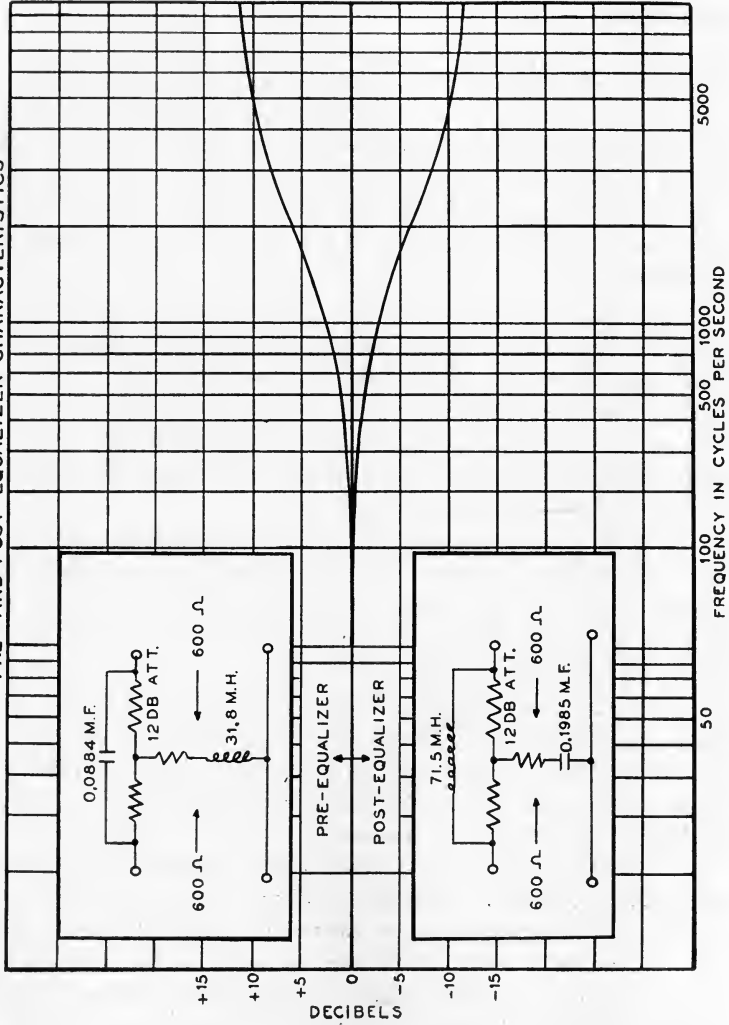

FIG. 1.

demonstration equipment. Hathaway has reported results both in the standard broadcast band and in television sound channels. His work is in agreement with others in that with this type of pre-equalization noise reduction as great as 10 db is obtained at the lower levels and somewhat less at higher levels due to the masking effect.

Parallel work carried on in the radio industry led to the adoption by the Radio Manufacturers Association of a pre- and post-equalizer. Most of the experimental work carried on in the industry has indicated that the RMA equalizer curve characteristics will best meet our recording requirements as long as the correct amount of equalization is used.

The recommended pre- and post-equalizer characteristics are shown in Fig. 1.

The experience to date with equalizers as herein recommended indicates that only an improvement and no penalty should be observed in orchestral recordings. However, in dialog and sound effects where an abnormally high amplitude of high frequencies is encountered, the recording system will have a greater tendency to overload. The equalizer selected seems to give a maximum of improvement with the introduction of a minimum of detrimental effects.

Therefore, this Committee as a result of theoretical consideration and practical tests, recommends that the Research Council adopt the attached curve as a **Research Council Industry Practice** for *Pre- and Post-Equalization for Studio Use*. This curve is in use in practically all of the studios recording variable density sound track. Although original recordings may be found containing a greater amount of pre-equalization than shown on the recommended curve, listening tests have determined that such material will play satisfactorily on the post-equalizer herewith recommended.

The recommended characteristic is accompanied by pre- and post-equalizer circuits designed to work in and out of a 600-ohm circuit. Circuit constants for such an equalizer are also given. These design data are included for informational purposes only and the input and output impedances are not a part of this Industry Practice.

Because of the relatively small amount of equipment in the studios compared to the amount of equipment in the theatres, new procedures and equipment are often used in recording before their use is practicable in the theatre. As yet pre- and post-equalization has not

been developed satisfactorily for theatre use and is not so recommended in this Report.

Respectfully submitted,

BASIC SOUND COMMITTEE

LOREN RYDER, *Chairman*

DANIEL J. BLOOMBERG	WILLIAM MUELLER
LESLIE I. CAREY	CLEM PORTMAN
C. W. FAULKNER	GORDON SAWYER
WESLEY C. MILLER	S. J. TWINING

REFERENCE

¹ LOYE, D. P., AND MORGAN, K. F.: "Sound Picture Recording and Reproducing Characteristics," *J. Soc. Mot. Pict. Eng.*, **XXXII** (June, 1939), p. 631.

FIFTY-FIFTH SEMI-ANNUAL TECHNICAL CONFERENCE

OF THE

SOCIETY OF MOTION PICTURE ENGINEERS

HOTEL PENNSYLVANIA, NEW YORK, N. Y.

APRIL 17-19, 1944

Officers in Charge

HERBERT GRIFFIN, *President*
EMERY HUSE, *Past-President*
L. L. RYDER, *Executive Vice-President*
W. C. KUNZMANN, *Convention Vice-President*
D. E. HYNDMAN, *Engineering Vice-President*
A. C. DOWNES, *Editorial Vice-President*
A. S. DICKINSON, *Financial Vice-President*
E. A. WILLIFORD, *Secretary*
M. R. BOYER, *Treasurer*

Directory of Committee Chairmen

Atlantic Coast Section	C. R. KEITH, <i>Chairman</i>
Papers Committee	W. H. OFFENHAUSER, JR., <i>Chairman</i>
	C. R. DAILY, <i>Vice-Chairman, West Coast</i>
Publicity Committee	JULIUS HABER, <i>Chairman, assisted by</i> HAROLD DESFOR
Membership and Subscription Committee	JAMES FRANK, JR., <i>Chairman</i>
Registration and Information	W. C. KUNZMANN
Reception and Local Arrangements	D. E. HYNDMAN
Luncheon and Dinner Dance	BARTON KREUZER
Hotel and Transportation	O. F. NEU
Projection Committee	H. F. HEIDEGGER, <i>Chairman, assisted by</i> Members New York Projectionists Local No. 306
Ladies' Reception Hostess	MRS. E. I. SPONABLE

Note: In order to comply with the wartime paper conservation program only names of the committee chairmen serving our conferences will be listed in released bulletins for the duration.

TENTATIVE PROGRAM

Monday, April 17, 1944

- 9:00 a.m. *Hotel, 18th Floor:* Registration.
 10:00 a.m. *Salle Moderne:* Convening the Conference with a **General Session** and committee reports.
 12:30 p.m. *Hotel Roof Garden:* **SMPE Get-Together Luncheon** for members, their families and guests.
 2:00 p.m. *Salle Moderne:* **Afternoon Session.**
 8:00 p.m. *Salle Moderne:* **Evening Session.**

Tuesday, April 18, 1944

- 9:00 a.m. *Hotel, 18th Floor:* Registration.
 10:00 a.m. *Salle Moderne:* **Morning Session.**
 2:00 p.m. *Salle Moderne:* **Afternoon Session.**
 8:00 p.m. *Georgian Room:* **Informal Dinner-Dance.**

Wednesday, April 19, 1944

Open morning.

- 1:30 p.m. *Hotel, 18th Floor:* Registration.
 2:00 p.m. *Salle Moderne:* **Afternoon Session.**
 8:00 p.m. *Salle Moderne:* **Evening Session and Adjournment.**

PAPERS

Members and others who desire to present technical papers before this Conference should communicate immediately with the Chairman or Vice-Chairman of the Papers Committee, whose names and addresses are given on the inside front cover of this issue. There is still time. Manuscripts received up to April 1st will be considered for listing in the final program. *Do not delay.* The Papers Committee will appreciate your cooperation, and you will contribute in large measure to the success of the Conference.

RESERVATIONS

The Hotel Pennsylvania management extends the following per diem rates, European plan, to SMPE delegates and guests:

Room with bath, one person	\$3.85—\$7.70
Room with bath, two persons, double bed	\$5.50—\$8.80
Room with bath, two persons, twin beds	\$6.60—\$9.90
Parlor suites: living room, bedroom, and bath	\$10.00, \$11.00, \$13.00, and \$18.00

The hotel room reservation cards will probably not be mailed to members until late in March because of unforeseen circumstances. Therefore, members and guests definitely planning to attend the Spring Conference should immediately advise the Headquarters Office of the Society, Hotel Pennsylvania, the type of

room accommodations desired and the date of arrival. Reservations so made will be protected until the cards are circulated to the membership for confirmation.

Owing to the heavy influx of visitors to New York, your coöperation will be greatly appreciated by the Hotel and Transportation Committee.

REGISTRATION

The registration headquarters will be located on the 18th floor of the hotel at the entrance of the Salle Moderne where all technical sessions will be held. Members and guests are expected to register and receive their Conference badges and identification cards for admittance. The fee is used to defray Conference expenses.

DINNER-DANCE AND GET-TOGETHER LUNCHEON

The 1944 Technical Conference Get-Together Luncheon will be held in the Roof Garden of the hotel on Monday, April 17, at 12:30 p.m.

The Dinner-Dance (informal—business dress and uniforms only) will be held in the Georgian Room of the hotel on Tuesday evening, April 18, at 8:00 p.m. It will be the Conference night for social get-together and dancing.

Note: Owing to existing food rationing and hotel labor problems it is imperative that your Luncheon and Dinner-Dance tickets be procured at the time of registering, thus assisting the Committee in providing accommodations. Therefore, we solicit your coöperation.

LADIES' RECEPTION HEADQUARTERS

There will be no special or prearranged ladies' entertainment program during the 1944 Conference. However, a reception parlor will be available in the hotel for the ladies' daily get-together and open house. Ladies attending the Spring Conference should register with Mrs. E. I. Sponable, Reception Hostess, to receive badges and identification cards.

MOTION PICTURES

Identification cards issued at the time of registration will be honored at a number of *deluxe* motion picture theaters in New York, the names of which will be published in later issues of the JOURNAL. There are many entertainment attractions available in New York to out-of-town delegates and guests, and information concerning them may be obtained at the hotel information desk or at the SMPE registration headquarters.

W. C. KUNZMANN
Convention Vice-President

Members planning to attend the Technical Conference should make arrangements for railroad accommodations immediately or at the latest one month in advance of the Conference date:

CURRENT LITERATURE OF INTEREST TO THE MOTION PICTURE ENGINEER

The editors present for convenient reference a list of articles dealing with subjects cognate to motion picture engineering published in a number of selected journals. Photostatic or microfilm copies of articles in magazines that are available may be obtained from The Library of Congress, Washington, D. C., or from the New York Public Library, New York, N. Y., at prevailing rates.

American Cinematographer

- 24 (Nov., 1943), No. 11
Lapse-Time for the Amateur (p. 396) C. JENKINS
Matching Lens Diaphragm Settings (p. 401) C. H. COLES
24 (Dec., 1943), No. 12
Psychological Photography (p. 430) S. O'DONNELL
Snow Photography (p. 432) A. WYKOFF AND J. SMITH
Aerial Photography, First Step to Battle (p. 435)
Electronic Tubes (p. 438) T. M. C. LANCE
Recent Developments in Sound-Tracks (p. 440) E. M. HONAN AND C. R. KEITH

British Kinematograph Society, Journal

- 6 (Jan., 1943), No. 1
Electronics in Kinematography (p. 3) A. G. D. WEST
Electronic Tubes (p. 6) T. M. C. LANCE
Electronics in Photometry (p. 12) G. B. HARRISON
Sound-on-Film Recording Equipment (p. 15) L. H. BACON
Sound-on-Film Reproducing Equipment (p. 19)
Fluorescent Lighting (p. 23) W. F. GARLING
The Mercury Arc Rectifier (p. 26) A. G. PENNY
Progress in Kinema Television (p. 29) C. H. BROWN
Catechol as a Hydroquinone Substitute (p. 33) G. PARR
I. D. WRATTEN AND G. I. P. LEVENSON
6 (July, 1943), No. 3
Plastics and Their Applications to Kinematography (p. 74) E. G. COUZENS AND V. E. YARSLEY
Art and Technique in Set Designing (p. 84) E. CARRICK

Educational Screen

22 (Oct., 1943), No. 8

Motion Pictures—Not for Theaters, Pt. 50
(p. 295)

A. E. KROWS

22 (Nov., 1943), No. 9

The Film and International Understanding
(p. 337)

J. E. DUGAN

Motion Pictures—Not for Theaters, Pt. 51
(p. 338)

A. E. KROWS

International Projectionist

18 (Nov., 1943), No. 11

Film and Apparatus for 16-Mm Projection
(p. 7)

A. NADELL

Conservation of Copper Oxide Rectifiers
(p. 10)S. E. THOMAS AND E. G.
MATHEWSONTelevision Today, II—Theory of Television
(p. 12)

J. FRANK, JR.

Drive-in Theaters of the Past, Present and
Future (p. 21)

L. CHADBOURNE

SOCIETY ANNOUNCEMENTS

ATLANTIC COAST SECTION

The 1944 season for the Atlantic Coast Section opened on January 19th with a meeting featuring high-speed cameras. Arranged by Clyde R. Keith, chairman, over 200 members and friends came to the Hotel Pennsylvania to hear representatives of three leading manufacturers explain the operation of their respective high-speed cameras, and viewed films taken in actual use in the solution of industrial problems. The speakers and their subjects were:

"The General Radio High-Speed Stroboscopic Recorder," by Martin A. Gilman, General Radio Company. From 500 to 1500 exposures per second are made on continuously moving 35-mm film by means of a flashing mercury arc lamp. No shutters or prisms are required.

"The Eastman High-Speed Camera, Type 3: A Modern Aid to Industrial Design and Production," by R. K. Waggershauser, Eastman Kodak Co., Rochester, N. Y. A rotating prism, continuous film camera taking up to 3000 frames per second on 16-mm film.

"Fastax: An Ultra-High-Speed Motion Picture Camera," by Frank Nickel, Jr., Western Electric Co., New York. Also a rotating prism continuous film camera in two types: one taking 16-mm pictures up to 4000 frames per second, and one taking 8-mm pictures up to 8000 frames per second.

A 16-mm sound film, *Cannons on Wings*, opened the program. Mr. Keith and the Board of Managers are planning to have other films of special interest for future meetings.

In response to many requests, the time of meetings has been advanced to 7:30 p. m. to permit earlier closings.

Only members of the Atlantic Coast Section in the metropolitan area of New York now receive notices of Section meetings. Others may have their names added to the mailing list upon request.

PACIFIC COAST SECTION

Alfred D. Brick, Pacific Coast Supervisor of Movietonews, addressed the Pacific Coast Section meeting on January 25th. His topic was "Photographing Action in the South Pacific." Mr. Brick was the only newsreel cameraman to cover the attack on Pearl Harbor, and has been present in seven major battles in the South Pacific theater. He also photographed the take-off of Jimmy Doolittle's flyers for Tokyo. Excerpts from Mr. Brick's newsreels were shown during the talk.

Incoming officers of the Section for 1944 were introduced to 200 members and guests gathered for the meeting on the Scoring Stage of RCA-Victor in Hollywood.

Now Being Distributed

THE TECHNIQUE OF MOTION PICTURE PRODUCTION

Covering current technical practices in motion picture production, presented as a Symposium at the 51st Semi-Annual Technical Conference of the SMPE in Hollywood, 1942. . . . Now published in book form.

160 Pages—41 Illustrations

Each section written by a specialist in the motion picture industry. . . Authentic information on various technical problems of motion picture production.

CONTENTS

- | | | |
|------|---|---|
| I | Technology in the Art of Producing Motion Pictures..... | Leon S. Becker |
| II | Cinematography in the Hollywood Studios:
Black and White Cinematography..... | John W. Boyle |
| | Putting Clouds into Exterior Scenes..... | Charles G. Clarke |
| | Technicolor Cinematography..... | Winton Hoch |
| III | Special Photographic Effects..... | Fred M. Sersen |
| IV | Re-Recording Sound Motion Pictures..... | L. T. Goldsmith |
| V | The Technique of Production Sound Recording.. | Homer G. Tasker |
| VI | Prescoring and Scoring..... | Bernard B. Brown |
| VII | Illumination in Motion Picture Production..... | R. G. Linderman, C. W. Handley and A. Rodgers |
| VIII | The Paramount Transparency Process Projection Equipment..... | Farciot Edouart |
| IX | Motion Picture Laboratory Practices..... | James R. Wilkinson |
| X | The Cutting and Editing of Motion Pictures... | Frederick Y. Smith |
| XI | The Projection of Motion Pictures..... | Herbert A. Starke |

THE TECHNIQUE OF MOTION PICTURE PRODUCTION is a useful and valuable reference for technicians, students, librarians, and others desiring technological data on the motion picture industry compiled in one volume.

Price \$3.50*

Published for the Society of Motion Picture Engineers by Interscience Publishers, Inc.,
215 Fourth Avenue, New York 3, N. Y.

* 20% discount to members in good standing if ordered through SMPE.
Orders must be accompanied by check or money order. Use form on other side.

**PREFACE TO
THE TECHNIQUE OF MOTION PICTURE PRODUCTION**

At the Spring 1942 Technical Conference of the Society of Motion Picture Engineers in Hollywood, California, a symposium was presented covering the current technical practices in the motion picture industry as applied to actual motion picture production. While information with regard to many of the subjects treated is scattered through the literature, no such complete descriptions of the various techniques involved had hitherto been assembled in such a logical, convenient, and highly educational sequence. The program was received with such acclaim by the audiences in attendance that the Board of Governors of the Society authorized the publication of these papers in book form, after their publication in the JOURNAL.

The papers of the symposium are presented in the general order of the steps taken in the production and presentation of motion pictures in the studios, laboratories, and theaters. Each section has been prepared by a man well fitted by his knowledge and experience in a particular field to give authentic information on the various problems arising in the manufacture of this great entertainment and educational medium.

It is the hope of the Society that this book will prove a useful and valuable guide to the general solution of the many problems which characterize the motion picture industry, in particular as these problems may be encountered in the post-war period of re-establishment and expansion throughout the world.

Order Form for The Technique of Motion Picture Production

**Society of Motion Picture Engineers
Hotel Pennsylvania
New York 1, N. Y.**

Date

Gentlemen:

Please send me **THE TECHNIQUE OF MOTION PICTURE PRODUCTION**
Enclosed is check or money order for

Name: No. Copies:

Address:

Member (\$2.80 per copy).*

Non-Member (\$3.50 per copy).

* Add 1% Sales Tax if mailed to New York City address.

JOURNAL OF THE SOCIETY OF MOTION PICTURE ENGINEERS

Vol 42

APRIL, 1944

No. 4

CONTENTS

	PAGE
The Fifty-Fourth Semi-Annual Meeting of the Society H. GRIFFIN	199
The New Acme-Dunn Optical Printer L. S. DUNN	204
War Standards for Motion Picture Equipment and Processes D. E. HYNDMAN	211
Direct Processes for Making Photographic Prints in Color C. E. K. MEES	230
Officers and Governors of the Society	239
Committees of the Society	242
Constitution and By-Laws of the Society	248
Journal Award and Progress Medal Award Regulations	259
Fifty-Fifth Semi-Annual Technical Conference	262
Current Literature	267
Society Announcements	268

(The Society is not responsible for statements of authors.)

Contents of previous issues, of the JOURNAL are indexed in the
Industrial Arts Index available in public libraries.

JOURNAL OF THE SOCIETY OF MOTION PICTURE ENGINEERS

HARRY SMITH, JR., EDITOR
ARTHUR C. DOWNES, *Chairman*
Board of Editors

JOHN I. CRABTREE ALFRED N. GOLDSMITH EDWARD W. KELLOGG
CLYDE R. KEITH ALAN M. GUNDELFINGER CHARLES W. HANDLEY
ARTHUR C. HARDY

Officers of the Society

- **President*: HERBERT GRIFFIN,
133 E. Santa Anita Ave., Burbank, Calif.
**Past-President*: EMERY HUSE,
6706 Santa Monica Blvd., Hollywood, Calif.
**Executive Vice-President*: LOREN L. RYDER,
5451 Marathon St., Hollywood, Calif.
***Engineering Vice-President*: DONALD E. HYNDMAN,
350 Madison Ave., New York, N. Y.
**Editorial Vice-President*: ARTHUR C. DOWNES,
Box 6087, Cleveland, Ohio.
***Financial Vice-President*: ARTHUR S. DICKINSON,
28 W. 44th St., New York, N. Y.
**Convention Vice-President*: WILLIAM C. KUNZMANN,
Box 6087, Cleveland, Ohio.
**Secretary*: E. ALLAN WILLIFORD,
30 E. 42d St., New York, N. Y.
**Treasurer*: M. R. BOYER
350 Fifth Ave., New York, N. Y.

Governors

- **FRANK E. CARLSON, Nela Park, Cleveland, Ohio.
*†CHARLES W. HANDLEY, 1960 W. 84th St., Los Angeles, Calif.
**EDWARD M. HONAN, 6601 Romaine St., Hollywood, Calif.
*†CLYDE R. KEITH, 195 Broadway, New York, N. Y.
**JOHN A. MAURER, 117 E. 24th St., New York, N. Y.
*HOLLIS W. MOYSE, 6656 Santa Monica Blvd., Hollywood, Calif.
*WILLIAM A. MUELLER, 4000 W. Olive Ave., Burbank, Calif.
*H. W. REMERSHIED, 716 N. La Brea St., Hollywood, Calif.
**EARL I. SPONABLE, 360 W. 54th St., New York, N. Y.
*JOSEPH H. SPRAY, 1277 E. 14th St., Brooklyn, N. Y.
*REEVE O. STROCK, 195 Broadway, New York, N. Y.
**WALLACE V. WOLFE, 1016 N. Sycamore St., Hollywood, Calif.

*Term expires December 31, 1944.

**Term expires December 31, 1945.

†Chairman, Pacific Coast Section.

‡Chairman, Atlantic Coast Section.

Subscription to non-members, \$8.00 per annum; to members, \$5.00 per annum, included in their annual membership dues; single copies, \$1.00. A discount on subscription or single copies of 15 per cent is allowed to accredited agencies. Order from the Society of Motion Picture Engineers, Inc., Hotel Pennsylvania, New York 1, N. Y.

Published monthly at Easton, Pa., by the Society of Motion Picture Engineers, Inc.
Publication Office, 20th & Northampton Sts., Easton, Pa.

General and Editorial Office, Hotel Pennsylvania, New York 1, N. Y.

Entered as second-class matter January 15, 1930, at the Post Office at Easton, Pa., under the Act of March 3, 1879. Copyrighted, 1944, by the Society of Motion Picture Engineers, Inc.

JOURNAL OF THE SOCIETY OF MOTION PICTURE ENGINEERS

Vol 42

APRIL, 1944

No. 4

THE FIFTY-FOURTH SEMI-ANNUAL MEETING OF THE SOCIETY*

HERBERT GRIFFIN**

This is the Fifty-Fourth Semi-Annual meeting of our Society. The twenty-fifth anniversary of its founding was commemorated by the silver bound issue of the JOURNAL of July, 1941.

We passed through World War I without serious dislocation, and there is little reason to believe we shall not do the same this time. It is true, however, that many of our members—approximately 100—are with the armed forces and many more have left the industry temporarily to join the staffs of some of the foremost research laboratories engaged in the development of instruments of war. The Society may feel proud of the contribution its members are making toward the preservation of our way of life.

The Society has enjoyed healthy growth since its inception in 1916, in the middle of the first World War, with 26 members, many of whom have since passed away. Our membership today amounts to 1358, representing, as it does, all branches of motion picture engineering. This does not mean, however, that our Society is as healthy as it might be, or that it has accomplished the job for the industry as set forth by its founder and first president, C. Francis Jenkins, who said, "We should recognize our responsibility to fix standards with due regard for the interests of all concerned." At that time, only one thing we worked with was standard throughout the world—the film—and the first dimensioned drawing in the Society's literature is that of the film itself. The slitting and perforation dimensions are the same as those in effect today.

The Society had then and still has as its main purpose the responsibility for bringing about standardization within the industry

* Prepared for the Technical Conference in Hollywood, Oct. 20, 1943, but not presented.

** President, Society of Motion Picture Engineers, 1943—.

of which we are a part. Standardization eliminates waste of time, money and materials, all of which is most necessary in these unfortunate times, and which should receive serious consideration in normal times.

Lack of standardization has undoubtedly robbed the world of many advantages, but in our case the Standards Committee, under the ever-watchful eye and capable direction of our Engineering Vice-President, Donald E. Hyndman, has kept on its toes, and is doing an excellent job.

Since its organization in 1916, the Society, through the efforts of the Standards Committee, has led the motion picture industry to accept technical improvements that have been major contributions for continuously increasing patronage at the box-office. These services rendered by the Society and its members have been gratis for all practical purposes. This statement is verified by the fact that the Society has been financed principally by its individual members, and the technical contributions made by the Society and its members have occurred without fanfare or general publicity.

Either through or by the Society, practically all standardization thus far achieved of methods, procedure, design, construction, operation, safety codes, definitions, abbreviations, *etc.*, has been accomplished. This standardization has improved equipment, methods, and procedures, which has resulted in increased production output at lower cost. These improvements have increased efficiency in the 3 major phases of the motion picture industry—production, distribution, and exhibition.

The fact that the Society sponsors the Sectional Committee on Motion Pictures (Z-22) of the American Standards Association, offers to the industry a direct and efficient means of presenting matters to be considered for standardization. Both the Committee on Standards of the SMPE and the Sectional Committee are composed of representative technical and engineering authorities from the motion picture industry representing producers, distributors, exhibitors, and manufacturers of all types of motion picture equipment and accessories.

There are 16 major engineering or technical committees of the Society reporting to the Engineering Vice-President. These committees deal with every engineering phase of the motion picture industry from cinematography to theater projection. Each committee is comprised of membership representative of technical and

engineering authorities, from each specific field of endeavor. All of the membership is appointed from the personnel of the producers, distributors, and exhibitors of the motion picture industry, and also from the manufacturers of equipment, accessories, and film.

Reports, data, specifications, or recommendations of procedure or tests are never published until each and every committee concerned with the material, the Board of Editors, and the Board of Governors have approved. This method of handling such important problems encourages profound faith in the practical application of the recommendation, as well as minimizing errors.

Since the first issue of the Society's official publication in 1916 up to the current issue, a tremendous number of valuable committee reports has been issued by the many committees which have become an integral part of the motion picture industry, and a goodly number of these are of particular value as reference sources, or as guides to recommended procedure.

The report of the motion picture Laboratory Practice Committee, published in the *JOURNAL* in 1936, is extensively used as a reference source of information on motion picture laboratory operation, types of equipment and film in general use, special processes and procedures, *etc.*

The report on Preservation and Storage of Film is a reference for detailed information on methods of preserving processed film and safe methods for storing it.

The report on Projection Room Plans has become practically the standard for specific data on the design, construction, and operation of a projection room.

Combination reports on the 2000-ft reel were instrumental in bringing about the adoption of 2000-ft reels as standard mounts for prints in the film exchange.

In addition to these specific engineering projects of past and present performance, as well as for proposed studies, it may be emphasized that the SMPE is the only technical and scientific organization that regularly publishes a *JOURNAL* which deals with technical and engineering problems of the motion picture industry. It is important to note that all of this work and publication have been done for the past 27 years with the most minute financial assistance from producer, distributor, or exhibitor organizations.

The Board of Governors and I, as President of your Society, feel very strongly that these organizations should strongly support

the Society through a substantial sustaining membership fee, in return for which data of concrete value could be obtained much more rapidly. The data then would be more thoroughly obtained and perhaps more reliable than from many other sources, because it would be prepared by engineers representing the four major factors which go to make up the industry—namely, the producers, distributors, exhibitors, and manufacturers of all types of equipment and film.

The contents of the JOURNAL of the Society have reflected the Society's deep interest in present-day problems. During the past two years the Society has published an ever-increasing number of papers devoted to conservation of equipment. Also, the JOURNAL has published many papers by representatives of the Army, Navy, and Air Forces concerning the part motion pictures are playing in training men for these services. A complete issue of the JOURNAL in September, 1943, was devoted to papers presented at the last Spring Meeting by the armed services, and in January, 1943, the complete edition of the JOURNAL was devoted to a symposium on the activities of the U. S. Army Motion Picture Service.

While all of the activities of SMPE committees, which I have enumerated, have a direct bearing on the war effort, much of the Society's work in the past has contributed indirectly to the important part motion pictures are playing in World War II. Standards for motion picture equipment have been recommended and approved by the Society, and subsequently by the American Standards Association, which make it possible for producers in Hollywood to create entertainment films and training films that can be projected on professional or portable equipment in the battle zones throughout the world. The film will run well through these projectors because the prints are all exactly alike in dimension and material; shipping containers and reels on which the film is wound are standardized to insure best protection enroute; and, because of specifications and standards studied and approved by SMPE committees, projectors and sound systems are built to exact standards which permit the films to be exhibited with the best possible results. Thus our boys and girls in the service all over this war-torn globe are able to enjoy needful recreation under the worst exhibition conditions.

In conclusion, may I ask that all members of our Society, both here and elsewhere throughout the nation, who are in a position to place the Society's aims and accomplishments forcefully before their

superiors, do so with a view of obtaining for the Society the financial support it so richly deserves.

I trust you are all enjoying your stay here in Hollywood, and that the program arranged by our Papers Committee and Arrangements Committee is meeting with your approbation. My personal thanks to all those who have worked so hard to make a success of this, our Fifty-Fourth Semi-Annual Meeting.

THE NEW ACME-DUNN OPTICAL PRINTER*

LINWOOD S. DUNN**

Summary.—An optical printer of radically new design and construction is described and illustrated. Besides doing all of the conventional optical printing effects, the new Acme-Dunn optical printer can make automatically driven dolly or "zoom" shots at any practical speed, make horizontal or vertical frame slide-off effects, wipe off in any direction at any speed, do frame-combination printing within a 12-frame cycle, and enlarge from 16-mm, including successful 3-frame separation negatives.

The optical printer has never to my knowledge been manufactured as a commercial product capable of efficiently handling all of the requirements of the modern motion picture studio and film laboratory. The studios themselves have designed and built their own printers, in most cases, and very often their machine shops have turned out a fine mechanical job, but they are inadequate from an operative and photographic standpoint, owing to obvious lack of close association with the optical expert in designing the machine.

The use of the optical printer to enhance the value of the modern motion picture is demanded increasingly by studios with foresight enough to give a free hand to the man in charge of the optical department. Excellent optical printer dolly and "zoom" shots are now being used in many productions with such success that they can not be distinguished from those shot on the set. When an imaginative optical printing specialist is not hampered by the limitations of his equipment, his value to his studio can be tremendous. He can, in most cases, improve a scene which may be faulty for some photographic reason such as density and quality, composition, action, etc., and can very often offer suggestions which may, by means of the optical printer, prevent an expensive retake.

In the Acme-Dunn optical printer the writer has utilized his 15 years of experience with major studio optical printing requirements

* Presented Oct. 18, 1943, at the Technical Conference in Hollywood.

** First Cinematographer, Charge of Optical Printing, RKO Radio Pictures, Inc., Hollywood.

in endeavoring to design a machine which can do anything that has been done on any all-purpose optical printer, with special emphasis on ease and flexibility of operation. Governmental demands for optical printers have afforded me the opportunity to design what I have often visualized as a "dream printer." Many mechanical problems presented themselves, but owing to the determination of the Acme

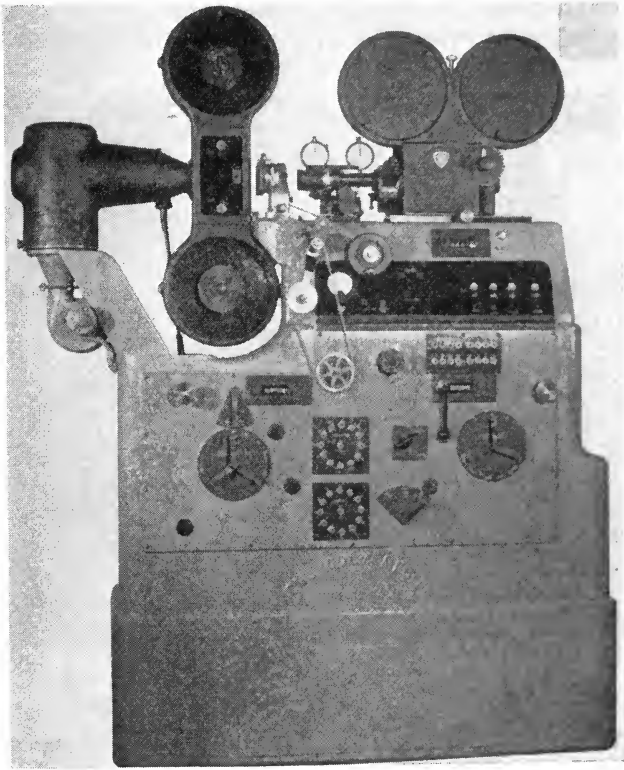

FIG. 1.

Tool Company of Burbank to build a first-class machine, these problems were overcome.

This optical printer is of radically new design, constructed as a complete unit, with cast iron base and housing, and low optical center. As shown in Fig. 1, all threading and operating are done from one side of the machine. Besides doing all of the conventional optical

printing effects such as dissolves, wipe-offs, reverse action, hold frame, *etc.*, it can do the following: make automatically driven dolly or zoom shots at any practical speed; make horizontal or vertical frame slide-off effects; wipe off in any direction at any speed; do any frame-combination printing within a 12-frame cycle; and enlarge from 16-mm, including successive 3-color separation negatives.

By means of the frame-combination printing mentioned above, a 16-mm Kodachrome film originally photographed at the speed of 16 frames per sec can be blown up to 35-mm color at 24 frames per sec

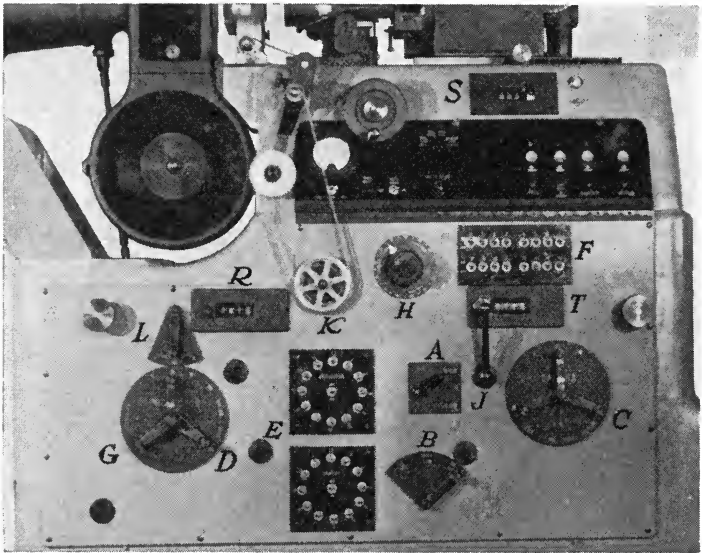

FIG. 2.

sound speed by setting the frame selector switches to repeat the 3 separation frames from every *second* 16-mm frame. Every other frame can be eliminated during continuous running without the use of the stop-motion clutches. All rewinding of film in the camera is accomplished at any speed by the reverse camera drive.

Fig. 2 shows the special features of the printer as follows: 4 speeds forward and reverse—10, 20, 30, and 60 ft per min—using a 220-v, $\frac{1}{2}$ -hp, 2-speed synchronous motor drive, controlled by switch *A* through a 2-speed transmission *B*; separate stop-motion clutch for camera *C* and projector *D*, individually controlled by a distributor

with selector switches *E* for any practical frame-combination printing; automatic actuation of either or both stop-motion clutches at any predetermined frame, controlled by selector switches *F*. This feature simplifies the making of innumerable effects, such as stopping in "sync" on an exact frame to make wipe-offs, *etc.*, and the making of fade-outs where the film being copied may be too short and would require a frame to be held during the uninterrupted course of the fade-out.

When the latter operation is required, a quick setting of the adjustable interlock *G* moves the synchronizing position of the projector head 90 degrees to allow each frame to stop at the stationary part of

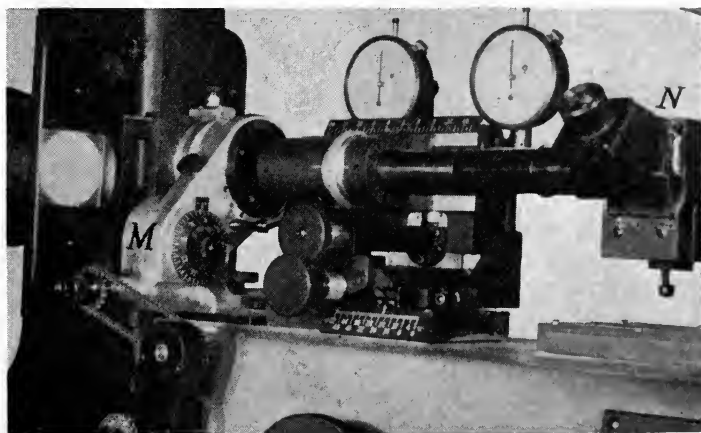

FIG. 3.

its cycle. This same adjustment is necessary when using the stop-motion clutches for frame-combination printing. *H* is a Variac for lamp voltage control. *J* controls the variable high-speed projector rewind motor drive. *K* is the special accessory drive, with forward, neutral, and reverse positions *L*, and is used to drive the wipe-off device, automatic zoom, vertical and horizontal lens movements, and other special-effects accessory devices.

In Fig. 3 we see the accessory drive hooked up to the wipe-off device *M*. By means of a quick change of sprockets with the extra shaft for compounding the gear ratio where necessary, any desired speed may be obtained. This is particularly valuable in making

traveling split-screen shots. The wipe-off device *M* is easily swiveled to any angle, moved forward or backward for different softness of edge, and wipe blades can be changed instantly for different types of edge blades.

Additional features include vertical and horizontal precision adjustments of the lens position independent of the camera, calibrated to 0.001 in. by dial indicators. Flexibility in adjusting the lens mount allows for reduction shots; focusing and viewing are done by sliding a prism behind the lens, diverting the image onto a ground glass at

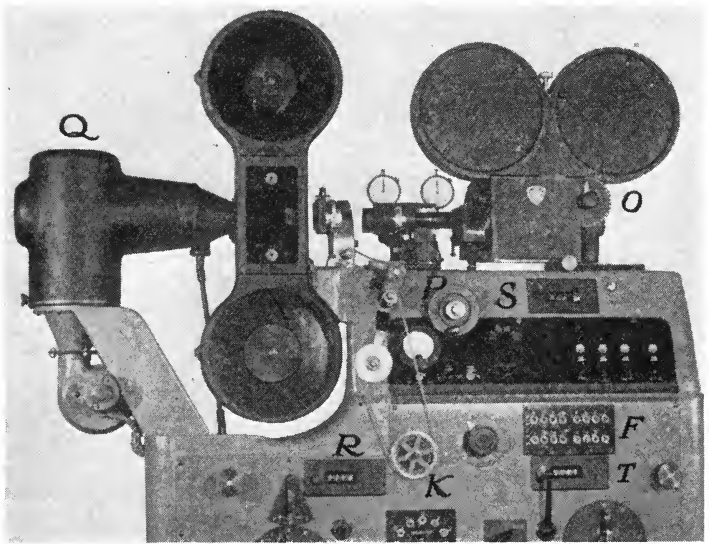

FIG. 4.

N. This view finder is fitted with registration pins to accommodate film for lining-up purposes.

The camera is a Bell & Howell type and is an integral part of the printer. As can be seen in Fig. 4 it is fitted with a hand shutter fade control *O*, which is the writer's preference, but a variable speed automatic fade is available. The camera has an anti-buckle switch which shuts off the motor drive. Camera and projector have automatic friction film take-ups.

In less than 10 min the 35-mm projector head can be interchanged for the 16-mm head. The automatic follow-focus dolly or zoom for-

ward and backward can be made by using either the hand crank *P* or the accessory drive *K*, and can magnify from less than the area of a 16-mm frame. Lens unit or camera can be disconnected from the follow-focus cam to allow for out-of-focus effect dissolves.

Printing light illumination is provided by a 1000-w forced air-cooled incandescent lamp *Q* with Variac voltage control. Light can be used diffused for the fast negative stocks, or open for making prints on the slow fine-grain positive stocks. An audible timer is provided which can be set by selector switches *F* to sound a buzzer as frequently as 16 times per ft to aid in timing the adjustments on any manually operated special-effects device.

Three film counters are mounted in the base: *R* is a frame counter for the projector head; *S* is the camera scene-footage counter with large 16-frame calibrated disk; and *T* is an extra counter usually used for cumulative camera footage.

Electric current required for this machine is 220 v a-c for the motor and 110 v a-c for the lamp. The lamp can be controlled by a voltage stabilizer if necessary.

Accessories available for the printer include a mounting for a rear lens in the projector head, which is used to focus an aerial image at the projector aperture for matting, retouching, and double printing; interchangeable double-spindle magazine flanges for printing 2 films at once in the projector head; roller micro-switch which rides on the edge of the projector film to actuate the stop-motion clutch, stopping at any previously notched frame to make light changes or other effects; extra "skeleton" projector head and lamp-house unit which mounts at a right angle to the optical center, and is driven by the accessory drive. Film in this head is photographed through a prism which is mounted so that it may be tilted, rocked, or spun completely around for innumerable additional special effects.

At the present time these printers are being made only for governmental use. The first machine was built for the U. S. Navy's Central Photographic Laboratory, Anacostia, Washington, D. C. Other printers are under construction for early delivery to The Training Film Production Laboratory, Wright Field Signal Corps, Dayton, Ohio; Signal Corps Photographic Center, Long Island City, New York; and the Coordinator of Inter-American Affairs, Mexico City.

The Acme-Dunn optical printer has turned out to be all we had hoped for, thanks to the close coöperation of the engineers of the Acme Tool Company. Their past record for building first-class mo-

tion picture equipment for 16 years is evident in the excellent workmanship done on these machines. It is earnestly hoped that the printers will prove to be an inspiration to the men operating them to work out new ideas and effects, in a field which is wide open for any one with imagination and ingenuity.

WAR STANDARDS FOR MOTION PICTURE EQUIPMENT AND PROCESSES

D. E. HYNDMAN*

The U. S. Army Pictorial Service on September 24, 1943, requested the Engineering Vice-President of the Society of Motion Picture Engineers to consider immediately the preparation of a group of Performance Specifications for motion picture equipment, accessories, and processes. It was emphasized that even though the request was initiated by the Army Pictorial Service, actually the request came from the Armed Forces represented by the U. S. Army Signal Corps, U. S. Army Air Forces, U. S. Army Engineer Corps, Bureau of Aeronautics, U. S. Navy, and U. S. Marine Corps. As the request was most urgent, an informal meeting of the Committee on Standards of the SMPE was called by the Chairman and the Engineering Vice-President to be held on September 27, 1943.

At this informal meeting officers of the U. S. Army Signal Corps and the Army Pictorial Service explained that 3 major items were of immediate concern to the Armed Forces:

- (1) Performance Specifications for 16-mm Sound Recording.
- (2) Performance Specifications for 16-mm Motion Picture Laboratory Processing.
- (3) Performance Specifications for 16-mm Sound Projectors to be used as service models.

During the discussion of these and other items it became apparent that the services of all the Engineering Committees of the SMPE would be required; a large amount of detail would necessitate much clerical and drafting work; and the cost would demand a financial appropriation to expedite the projects beyond the means of the SMPE. It was recommended that possibly a War Standards Committee of the American Standards Association could be appointed to direct this project. This Committee might be financed by the War Production Board, sponsored by the Armed Forces, and then the SMPE would offer to undertake the preparation of Performance

* Engineering Vice-President of the Society.

Specifications for only motion picture equipment, accessories, and processes.

It was agreed the SMPE would immediately commence preparation of these Performance Specifications provided (1) that at an official meeting of the Committee on Standards this action was approved, (2) that the Board of Governors of the SMPE approved, (3) that a financial appropriation be made available to defray adequately the costs of detailed secretarial, clerical, drafting work, *etc.*, and (4) that if, in the future, any organization or group is appointed by a U. S. Government agency to do like work the SMPE would offer its engineering services on the project.

An official meeting of the Committee on Standards was held on October 7, 1943, which was attended by most members of the Committee and representatives of the U. S. Army Signal Corps, U. S. Army Air Forces, U. S. Army Engineer Corps, Bureau of Aeronautics, U. S. Navy, and U. S. Marine Corps for the Armed Forces. The discussion which ensued at the informal meeting was reviewed. Further details of experiences and difficulties with currently available 16-mm motion picture equipment and 16-mm sound prints, as used by the Armed Forces, were presented by its members. The Armed Forces announced that a letter had been sent on September 24, 1943, to the Director of the Conservation Division, War Production Board, Washington, D. C., recommending that formation of an American War Standards Committee on Photography and Cinematography, sponsored by the WPB and completely coöperating with all military photographic services, would be of great help to these services and to the motion picture industry. It was suggested also that a limited number of manufacturers and engineering societies concerned with these photographic equipment, film and processing problems be requested to aid in the promulgation of reasonable performance specifications and practical standards in order to have the projects proceed with a minimum of delay. In the recommendation to the WPB several additional projects directly concerned with still photography and 35-mm cinematography were presented.

It was unanimously agreed by all members of the Committee on Standards that the SMPE should immediately organize committees of authoritative engineers and practical technicians to coöperate with the Armed Forces on these projects and to be prepared to offer the services of these committees to the WPB or any agency it appointed. This procedure was to be subject, however, to the provisions decided

on at the informal meeting of the Committee on Standards, held on September 27, 1943. The Armed Forces indicated that the projects dealing with 16-mm equipment, accessories, and processes were of preferential importance and that Performance Specifications for a service model 16-mm sound projector were of first order.

Invitations to attend a meeting on October 11, 1943, at the American Standards Association in New York City were sent by the Director of the Conservation Division of the WPB to representatives of the Armed Forces, to manufacturers of still and motion picture photographic equipment, and to other interested parties. The advisability of undertaking a project of standardization of still and motion picture photographic equipment and processes was to be discussed. At this meeting, the following resolution was unanimously adopted:

"The preparation of war specifications and standards in the fields of photography and cinematography be referred to an American Standards Association War Standards Committee on Photography and Cinematography sponsored by the War Production Board.

"A Subcommittee of the ASA War Standards Committee on Photography and Cinematography, comprised of representatives of the Armed Forces, shall be appointed to determine those projects on which specification and standardization work is desired by the Armed Forces, and to indicate further their priority."

In view of this unanimity of opinion, the WPB requested the American Standards Association to form a War Standards Committee to develop a project for standardization of photographic and cinematographic equipment and processes under the contract existing between the ASA and WPB. All projects undertaken must have approval and order of priority from both the ASA and the Conservation Division of the WPB.

After this meeting the Engineering Vice-President and the Chairman of the Committee on Standards of the SMPE and the Chairman of Sectional Committee on Motion Pictures Z-22 of the ASA, in consultation with the Chairman of the Armed Forces Committee on Photography and Cinematography, appointed the following Subcommittees of the Committee on Standards of the SMPE:

- (1) Subcommittee No. I on 16-mm Cinematography.
- (2) Subcommittee No. II on 16-mm Sound Recording.
- (3) Subcommittee No. III on 16-mm Laboratory Practice.
- (4) Subcommittee No. IV on 16-mm Projection Practice.

Unanimous approval of the action by the Committee on Standards

was received from the Board of Governors at their meeting in Hollywood, California, on October 17, 1943. The Secretary was instructed to inform the Secretary of the ASA that the SMPE was prepared to work on any tasks assigned and to expedite this work with a minimum of delay.

The new ASA War Standards Committee on Photography and Cinematography Z-52 held its organization meeting on December 15, 1943. In addition to representation from various branches of the Armed Forces and from manufacturers of photographic equipment, accessories, and film, there are liaison representatives from the War Production Board, Society of Motion Picture Engineers, and the Research Council of the Academy of Motion Picture Arts and Sciences. R. B. Shepard, Assistant Director of the Conservation Division of the War Production Board, was appointed Chairman, and J. W. McNair, American Standards Association staff, was appointed Secretary.

Recommendations of specific projects for consideration immediately were outlined by Captain Lloyd T. Goldsmith, Chairman of the Armed Forces Committee. The Committee made definite assignment of all the projects requested and instructed the Subcommittees or Task Committees to proceed with the utmost speed in the development of the specifications. The SMPE had 4 Subcommittees organized and ready to begin work and, in several cases, existing Subcommittees of the ASA Committee on Photography Z-38, augmented by additional members from the Armed Forces, were assigned jobs. In 3 cases, the SMPE and the Research Council of the Academy of Motion Picture Arts and Sciences were requested to recommend Subcommittees to do specific additional tasks.

JOB ASSIGNMENT SHEET FOR ASA WAR COMMITTEE ON PHOTOGRAPHY AND CINEMATOGRAPHY (Z-52)

Subcommittee A

(1) Development of a Specification for the Size and Shape of the Photographic Picture Aperture for 16-mm Motion Picture Cameras.

(2) Development of a Specification for the Size and Shape of Apertures for 16-mm Motion Picture Camera View Finders.

(3) Development of a Specification for a Standard Registration Distance for 16-mm Motion Picture Camera Lenses.

Subcommittee B

(1) Development of a Specification for 16-mm Motion Picture Sound Test Films. Special attention is to be given to calibration

AMERICAN STANDARDS ASSOCIATION

WAR COMMITTEE ON PHOTOGRAPHY AND CINEMATOGRAPHY—Z-52

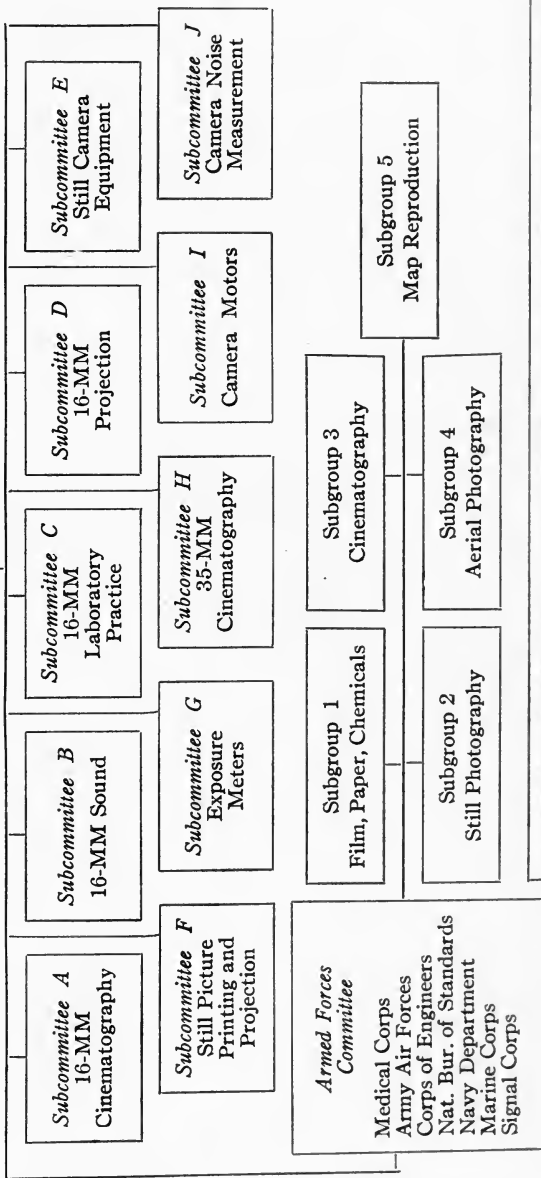

ORGANIZATION CHART—WAR COMMITTEE ON PHOTOGRAPHY AND CINEMATOGRAPHY—Z-52
 Showing Armed Forces and ASA Subcommittee Structure for Development of Specifications for Photographic and Cinematographic Materials and Apparatus for the Armed Forces
 American Standards Association, 29 West 39th St., New York 18, N. Y.

of the sound-track and prescribed methods of measuring its characteristics. A source of supply is to be established so that these films will be available to all manufacturers and users of 16-mm motion picture sound equipment.

Subcommittee C

(1) Development of a Specification for Standards of Quality and Control of Processing and Printing on 16-mm Film. Test procedures and methods, and standards of test are to be specified in detail for the regular negative-positive, black-and-white reversal, and color reversal processes.

(2) Development of a Specification for the Size and Shape of 35-mm to 16-mm Picture Apertures of Optical Reduction Printers, and also 16-mm Contact Printers.

(3) Development of a Specification for 35-mm and 16-mm Motion Picture Negative and Print Nomenclature. Considerable confusion has existed between the motion picture industry and the Armed Forces owing to lack of agreement on terms for various types of processed films.

Subcommittee D

(1) Development of a Specification for a Service Model 16-mm Sound Projector. The specification should include the military characteristics required, such as: interchangeability of parts, operation in a wide range of temperature and humidity, resistance to severe shock and rough transport, *etc.*; the over-all performance characteristics required; and the methods and test of the equipment.

(2) Development of a Specification for 16-mm Portable Motion Picture Projection Screens. Special attention is to be given to optimum reflectivity, moisture resistance qualities, durability as regards folding and shipping, and screen sizes. This specification must also evaluate matte and metallic surfaces for Vectograph and color projection.

(3) Development of a Specification for 16-mm Motion Picture Visual Test Films. Special attention is to be given to calibration of the visual tests and prescribed methods of measuring their characteristics. A source of supply is to be established so that these films will be available to all manufacturers and users of 16-mm motion picture equipment.

Subcommittee E

(1) Development of a Specification for Measuring the Performance Characteristics of Still Camera Shutters. This is to be performance standards which include temperature and humidity ranges of test, methods and procedures of test, and standards of nomenclature.

Subcommittee F

(1) Development of a Specification of Performance and Test for Still Picture Contact Printers. Special attention is to be given the test procedure and the source and use of test screens as related to the work already in progress by ASA Committee Z-38.

(2) Development of a Specification for Slide Film Projectors. This specification should include both manually and electrically operated projectors for 35-mm slide films and 2 × 2-in. slides, but not microfilm readers. Special attention is to be given to maximum allowable aperture temperatures, dimensional standards, interchangeability of parts and projection lamps, standard lens barrel diameters, and also lenses having a desirable range of focal lengths.

Subcommittee G

(1) Development of a Specification for Measuring the Performance Characteristics and Methods of Test for Photographic Exposure Meters. Special attention is to be given to operating temperature range, degree of accuracy, and test procedure.

Subcommittee H

(1) Development of a Specification for the Size and Shape of the Photographic Picture Aperture of a 35-mm Motion Picture Sound Camera. Preliminary studies have been made on this subject by the SMPE and the Research Council of the Academy of Motion Picture Arts and Sciences which will serve as references.

(2) Development of a Specification for the Size and Shape of Apertures for the 35-mm Motion Picture Sound Camera View Finder.

(3) Development of a Specification for a Standard Registration Distance for 35-mm Motion Picture Camera Lenses. The present noninterchangeability of lenses from one camera to another owing to variation in registration distances is the source of continuous trouble to the Armed Forces as well as civilian industry.

Subcommittee I

(1) Development of a Specification for a 35-mm Motion Picture Camera Drive Motor to operate from either 12- or 24-v d-c. Both voltages are now widely used by a majority of the Armed Forces. Standard aircraft voltage is 24 and standard ground voltage is 12.

Subcommittee J

(1) Development of a Specification for Noise Measurements and Acceptable Limits for both 35-mm and 16-mm Motion Picture Sound Cameras. Preliminary studies of this subject have been made by the Research Council of the Academy of Motion Picture Arts and Sciences which will serve as a guide to evolution of a standardized procedure.

Subcommittees of ASA Z-52

ASA Designation	Former Designation
Subcommittee A	SMPE Subcommittee No. I
Subcommittee B	SMPE Subcommittee No. II
Subcommittee C	SMPE Subcommittee No. III
Subcommittee D	SMPE Subcommittee No. IV
Subcommittee E	Subcommittee No. 4 of Z-38
Subcommittee F	Subcommittee No. 7 of Z-38
Subcommittee G	Subcommittee on Exposure Meters
Subcommittee H*	1st Special Subcommittee
Subcommittee I*	2d Special Subcommittee
Subcommittee J*	3d Special Subcommittee

WAR STANDARDS COMMITTEE ON PHOTOGRAPHY AND CINEMATOGRAPHY (Z-52)

SHEPARD, ROBERT, *Chairman*
Underwriters' Labs., Inc.
161 Sixth Ave.
New York 13, N. Y.

FRITZE, J. R. **
Conservation Division
WPB, Dept. 5210
Room 236, Temporary Bldg. D
Washington, D. C.

ARNOLD, PAUL
FORREST, JOHN **
AnSCO
Binghamton, N. Y.

BATSEL, M. C.
SACHTLEBEN, L. T. **
RCA Victor Div.
Radio Corp. of America
501 N. LaSalle St.
Indianapolis 1, Ind.

BARNETT, HERBERT
LORANCE, G. T. **
International Projector Corp.
92 Gold St.
New York 7, N. Y.

BRETHAUER, F. L.
Bell & Howell Co.
7100 McCormick Rd.
Chicago 45, Ill.

* Membership on these Subcommittees is being appointed by the SMPE and the Research Council of the Academy of Motion Picture Arts and Sciences.

** Alternate.

CAHILL, LT. COL. F. E., JR.

Army Pictorial Service
Office of the Chief Signal Officer
5A1058 Pentagon Bldg.
Washington 25, D. C.

COLTON, CAPT. EDWARD

Eng. Div., Photo Lab.
Matériel Command
Army Air Forces
Wright Field
Dayton, Ohio

CREER, CAPT. R. P.

Museum & Medical Arts Service
Army Medical Museum
7th St. & Independence Ave., S. W.
Washington 25, D. C.

DAME, MAJOR R. B.

HQ, Army Air Forces
ACAS/OCR Technical Service Div.
Motion Picture Branch
5E195 Pentagon Bldg.
Washington 25, D. C.

DAVIS, RAYMOND

National Bureau of Standards
Washington 25, D. C.

DOYLE, I. W.

Fairchild Aviation Corp.
88-06 Van Wyck Blvd.
Jamaica, N. Y.

GACKI, L. W.*

Fairchild Aviation Corp.
475 Tenth Ave.
New York 18, N. Y.

FOX, E. J.

Asst. Washington Rep.
Canadian Wartime Prices and Trade
Board
Room 3068
Railroad Retirement Bldg.
Washington, D. C.

GOLDSMITH, DR. A. N.

580 Fifth Ave.
New York 19, N. Y.

GOLDSMITH, CAPT. L. T.

Signal Corps Photographic Center
35-11 35th Ave.
Long Island City 1, N. Y.

HYNDMAN, D. E.

Eng. Vice-Pres.
Society of Motion Picture Engineers
c/o Eastman Kodak Co.
350 Madison Ave.
New York 17, N. Y.
WILLIFORD, E. A.*
National Carbon Co.
30 East 42d St.
New York 17, N. Y.

JONES, DR. L. A.

Eastman Kodak Co.
Kodak Park Works
Rochester 4, N. Y.

KIVELL, LT. (J.G.) L. M.

HAYNIE, LT. J. M.*
Room 1809
Bureau of Aeronautics
Navy Dept.
Washington 25, D. C.

LORENZ, MAJOR G. G.

The Engineer Board
Fort Belvoir, Va.

MILLER, W. C.

Research Council of the Academy of
Motion Picture Arts & Sciences
Suite 1217, Taft Bldg.
Hollywood 28, Calif.

NEIS, COL. B. L.

Chief, Standards & Specifications Sec.
Conservation Br., Production Div.
HQ, Army Services Forces, War Dept.
4C633 Pentagon Bldg.
Washington 25, D. C.

NEMEC, LT. BOYCE

Signal Corps Photographic Center
35-11 35th Ave.
Long Island City 1, N. Y.

QUACKENBUSH, COMDR. R. S.

Bureau of Aeronautics
Navy Dept.
Washington 25, D. C.

RAYTON, W. B.

Dir. of Scientific Bureau
PESTRECOV, DR. K.*
Bausch & Lomb Optical Co.
Rochester 2, N. Y.

* Alternate.

RICHARDSON, MAJOR J. R.
4218 War Dept. Bldg.

Washington 25, D. C.

FRENCH, F. W. C.*

Office, Asst. Chief of Engr. for War
Planning

Military Intelligence Div.

4223 War Dept. Bldg.

Washington 25, D. C.

VAUGHN, W. S.

Eastman Kodak Co.

343 State St.

Rochester 4, N. Y.

WHITAKER, G. C.

WHITMAN, V. E.*

Folmer Graflex Corp.

154 Clarissa St.

Rochester 8, N. Y.

WHITE, DR. D. R.

Redpath Laboratory

E. I. du Pont de Nemours & Co., Inc.

Parlin, N. J.

BOYER, M. R.*

E. I. du Pont de Nemours & Co.,
Inc.

350 Fifth Ave.

New York 1, N. Y.

ARMED FORCES COMMITTEE ON PHOTOGRAPHY AND CINEMATOGRAPHY

GOLDSMITH, CAPT. L. T.,⁵ *Chairman*
OC, Pictorial Engineering & Research
Laboratory

Signal Corps Photographic Center

35-11 35th Ave.

Long Island City 1, N. Y.

NEMEC, LT. BOYCE,⁵ *Secretary*

OC, Equipment Specifications Branch
Pictorial Engineering & Research Lab-
oratory Div.

Signal Corps Photographic Center

35-11 35th Ave.

Long Island City 1, N. Y.

AMES, CAPT. R. F.¹

Asst. for M & E Photo

Operations, Commitments & Require-
ments Div.

Headquarters Army Air Forces

4E1083 Pentagon Bldg.

Washington 25, D. C.

CAHILL, LT. COL. F. E., JR.⁵

Executive Officer, Army Pictorial Serv-
ice

Office of the Chief Signal Officer

5A1058 Pentagon Bldg.

Washington 25, D. C.

COLBY, LT. W.⁴

Bureau of Aeronautics

Washington 25, D. C.

COLTON, CAPT. E.¹

Photographic Laboratory

Wright Field

Dayton, Ohio

CREER, CAPT. R. P.³

Museum and Medical Arts Service

Army Medical Museum

7th St. & Independence Ave., S. W.

Washington 25, D. C.

DALY, CAPT. P. J.¹

Matériel Division

Development Engineering Branch

Pentagon Bldg.

Washington 25, D. C.

DAVIS, RAYMOND

National Bureau of Standards

Washington, D. C.

GROVES, MAJOR G. R.¹

1st Motion Picture Unit

88-22 W. Washington Blvd.

Culver City, Calif.

KIVELL, LT. (J.G.) L. M.⁴

Bureau of Aeronautics (Photo)

Washington 25, D. C.

¹ Representing Army Air Forces.

² Representing Corps of Engineers.

³ Representing Medical Department.

* Alternate.

⁴ Representing Navy Department.

⁵ Representing Signal Corps.

⁶ Representing U. S. Marine Corps.

LEMEN, CAPT. J. W.⁶
 Headquarters U. S. Marine Corps
 Washington 25, D. C.

LOVE, CAPT. R. F.¹
 Asst. for M & E Photo
 Operations, Commitments & Require-
 ments Div.
 Headquarters Army Air Forces
 4E1083 Pentagon Bldg.
 Washington 25, D. C.

LUND, MAJOR S. D.⁵
 Chief, Field Activities Branch
 Army Pictorial Service
 Office of the Chief Signal Officer
 Pentagon Building
 Washington 25, D. C.

PESCE, LT. JOSEPH S.¹
 First Motion Picture Unit
 88-22 W. Washington Blvd.
 Culver City, Calif.

PIERCE, LT. COL. G. McG.⁶
 Division of Plans & Policies
 Headquarters U. S. Marine Corps
 Washington 25, D. C.

QUACKENBUSH, COMMANDER R. S.⁴
 Bureau of Aeronautics
 Washington 25, D. C.

RICHARDSON, MAJOR J. R.²
 Intelligence Division
 Office Chief of Engineers
 4218 New War Dept. Bldg.
 Washington 25, D. C.

STOVALL, F. J.
 National Bureau of Standards
 Washington, D. C.

ZARNOW, LT. G. B.⁶
 Headquarters U. S. Marine Corps
 Washington 25, D. C.

SUBCOMMITTEE A ON 16-MM CINEMATOGRAPHY (Z-52)

CONTNER, J. B., *Chairman*
 WORRALL, GEORGE*
 Cineflex Corp.
 305 East 63d St.
 New York 21, N. Y.

KEITH, C. R., *Vice-Chairman*
 Electrical Research Products Div.
 Western Electric Co.
 195 Broadway
 New York 7, N. Y.

BERNDT, E. M.
 BUSCH, G. A.*
 E. M. Berndt Corp.
 5515 Sunset Blvd.
 Hollywood 28, Calif.

CLARK, L. E.
 POHL, W. E.*
 Technicolor Motion Picture Corp.
 6311 Romaine St.
 Hollywood 38, Calif.

BRETHAUER, F. L.
 Bell & Howell Co.
 7100 McCormick Rd.
 Chicago 45, Ill.
 KERST, W. D.*
 Bell & Howell Co.
 30 Rockefeller Plaza
 New York 20, N. Y.

COLLINS, M. E.
 GUNBY, O. B.*
 RCA Victor Division
 Radio Corp. of America
 1016 N. Sycamore St.
 Los Angeles 38, Calif.

CARVER, DR. E. K.
 HOOD, H. J.*
 Eastman Kodak Co.
 Rochester 4, N. Y.

DAVIDSON, J. C.
 MORGAN, K. F.*
 Electrical Research Products Div.
 Western Electric Co.
 6601 Romaine St.
 Los Angeles 38, Calif.

CHAMBERS, LT. G. A., USNR
 Photographic Science Lab.
 Naval Air Station
 Anacostia, D. C.

FARNHAM, R. E.
 CARLSON, F. E.*
 General Electric Co.
 Nela Park
 Cleveland 12, Ohio

* Alternate.

LESSLER, L.
IDANK, JOSEPH*
AnSCO
Binghamton, N. Y.

LYMAN, D. F.
Eastman Kodak Co.
Rochester 4, N. Y.

MAURER, J. A.
HOLSLAG, R. C.*
J. A. Maurer, Inc.
117 East 24th St.
New York 10, N. Y.

NORLING, J. A.
Loucks & Norling Studios
245 West 55th St.
New York 19, N. Y.

PESTRECOV, DR. K.
Bausch & Lomb Optical Co.
Rochester, N. Y.

SCHEICK, J. A.*
Bausch & Lomb Optical Co.
30 Rockefeller Plaza
New York 20, N. Y.

SACHTLEBEN, L. T.
DREW, R. O.*
RCA Victor Division
Radio Corp. of America
501 N. LaSalle St.
Indianapolis 1, Ind.

STROHM, CAPT. JAMES
GOLDSMITH, CAPT. L. T.*
Signal Corps Photographic Center
35-11 35th Ave.
Long Island City 1, N. Y.

WEISS, DR. J. P.
WHITE, DR. D. R.*
Redpath Laboratory
E. I. du Pont de Nemours & Co., Inc.
Parlin, N. J.

SUBCOMMITTEE B ON 16-MM SOUND (Z-52)

MAURER, J. A., *Chairman*
J. A. Maurer, Inc.
117 East 24th St.
New York 10, N. Y.

SANDVIK, DR. OTTO, *Vice-Chairman*
Eastman Kodak Company
Research Laboratory
Rochester 4, N. Y.

CARLSON, F. E.
FARNHAM, R. E.*
General Electric Co.
Nela Park
Cleveland 12, Ohio

D'ARCY, E. W.
POWERS, JOHN*
De Vry Corp.
1111 Armitage Ave.
Chicago 14, Ill.

CHAMBERS, LT. G. A., USNR
Photographic Science Lab.
Naval Air Station
Anacostia, D. C.

DREW, R. O.
SACHTLEBEN, L. T.*
RCA Victor Division
Radio Corp. of America
501 N. LaSalle St.
Indianapolis 1, Ind.

CLARK, L. E.
POHL, W. E.*
Technicolor Motion Picture Corp.
6311 Romaine St.
Hollywood 38, Calif.

FORREST, JOHN
MANN, GORDON*
AnSCO
Binghamton, N. Y.

COLLINS, M. E.
GUNBY, O. B.*
RCA Victor Division
Radio Corp. of America
1016 N. Sycamore St.
Los Angeles 38, Calif.

GRIGNON, F. W.
BERTRAM, E. A.*
DeLuxe Laboratories, Inc.
850 Tenth Ave.
New York 19, N. Y.

CORBIN, R. M.
CARVER, DR. E. K.*
Eastman Kodak Co.
Rochester 4, N. Y.

LESSER, LT. J. L.
Photographic Section
Marine Corps Schools
Quantico, Va.

* Alternate.

MESCHTER, DR. E.

WHITE, DR. D. R.*

Redpath Laboratory

E. I. du Pont de Nemours & Co., Inc.

Parlin, N. J.

MISENER, MAJOR GARLAND

GOLDSMITH, CAPT. L. T.*

Signal Corps Photographic Center

35-11 35th Ave.

Long Island City 1, N. Y.

MORGAN, K. F.

Electrical Research Products Div.

Western Electric Co.

6601 Romaine St.

Los Angeles 38, Calif.

KEITH, C. R.*

Electrical Research Products Div.

Western Electric Co.

195 Broadway

New York 7, N. Y.

OFFENHAUSER, W. H., JR.

4 West 43d St.

New York 18, N. Y.

HARRIS, SYLVAN*

J. A. Maurer, Inc.

117 East 24th St.

New York 10, N. Y.

PESCE, LT. J. S.

1st Motion Picture Unit

Army Air Forces

88-22 W. Washington Blvd.

Culver City, Calif.

PIERCE, LT. COL. G. McG.*

Headquarters

U. S. Marine Corps

Washington 25, D. C.

THOMPSON, LLOYD

The Calvin Company

616 West 26th St.

Kansas City 8, Mo.

TRENDLER, A. L.

Bell & Howell Co.

1801 Larchmont Ave.

Chicago 13, Ill.

PALMER, M. W.*

Bell & Howell Co.

30 Rockefeller Plaza

New York 20, N. Y.

WILSON, HENRY

SHAPIRO, A.*

Ampro Corporation

2839 N. Western Ave.

Chicago 18, Ill.

SUBCOMMITTEE C ON 16-MM LABORATORY PRACTICE (Z-52)

BOYER, M. R., *Chairman*

E. I. du Pont de Nemours & Co., Inc.

350 Fifth Ave.

New York 1, N. Y.

WHITE, H. E., *Vice-Chairman*

Eastman Kodak Co.

350 Madison Ave.

New York 17, N. Y.

BERTRAM, E. A.

GRIGNON, F. W.*

DeLuxe Laboratories, Inc.

850 Tenth Ave.

New York 19, N. Y.

30 Rockefeller Plaza

New York 20, N. Y.

BLANEY, A. C.

MCKIE, R. V.*

RCA Victor Division

Radio Corp. of America

1016 N. Sycamore Ave.

Hollywood 38, Calif.

CHAMBERS, LT. G. A., USNR

Photographic Science Lab.

Naval Air Station

Anacostia, D. C.

CLARK, L. E.

POHL, W. E.*

Technicolor Motion Picture Corp.

6311 Romaine St.

Hollywood 38, Calif.

BRETHAUER, F. L.

Bell & Howell Co.

7100 McCormick Rd.

Chicago 45, Ill.

PALMER, M. W.*

Bell & Howell Co.

CORBIN, R. M.

CARVER, DR. E. K.*

Eastman Kodak Co.

Rochester 4, N. Y.

* Alternate.

- DEPUE, O. B.
O. B. Depue, Inc.
7512 N. Ashland Ave.
Chicago 26, Ill.
DEPUE, BURTON*
Burton Holmes Laboratories, Inc.
7510 N. Ashland Ave.
Chicago 26, Ill.
- DREW, R. O.
SACHTLEBEN, L. T.*
RCA Victor Division
Radio Corp. of America
501 N. LaSalle St.
Indianapolis 1, Ind.
- DURVEA, ALBERT
TRONOLONE, N.*
Pathe Labs., Inc.
625 Madison Ave.
New York 22, N. Y.
- FARNHAM, R. E.
CARLSON, F. E.*
General Electric Co.
Nela Park
Cleveland 12, Ohio
- FORREST, JOHN
MANN, GORDON*
AnSCO
Binghamton, N. Y.
- GASKI, T. J.
CANTOR, E.*
Consolidated Film Industries, Inc.
Consolidated Park
Fort Lee, N. J.
- HILLMAN, W. P.
WHITE, DR. D. R.*
Redpath Laboratory
E. I. du Pont de Nemours & Co., Inc.
Parlin, N. J.
- HUSE, EMERY
CHASE, LEO*
Eastman Kodak Co.
6706 Santa Monica Blvd.
Hollywood 38, Calif.
- LAGRANDE, FRANK
RICHARDS, ARTHUR*
Paramount Pictures, Inc.
43-20 34th St.
Long Island City 1, N. Y.
- MAURER, J. A.
HOLSLAG, R. C.*
J. A. Maurer, Inc.
117 East 24th St.
New York 10, N. Y.
- MISENER, MAJOR GARLAND
GOLDSMITH, CAPT. L. T.*
Signal Corps Photographic Center
35-11 35th Ave.
Long Island City 1, N. Y.
- MORGAN, K. F.
Electrical Research Products Div.
Western Electric Co.
6601 Romaine St.
Los Angeles 38, Calif.
KEITH, C. R.*
Electrical Research Products Div.
Western Electric Co.
195 Broadway
New York 7, N. Y.
- MOYSE, H. W.
E. I. du Pont de Nemours & Co., Inc.
6656 Santa Monica Blvd.
Hollywood 38, Calif.
- OFFENHAUSER, W. H., JR.
4 West 43d St.
New York 18, N. Y.
HARRIS, SYLVAN*
J. A. Maurer, Inc.
117 East 24th St.
New York 10, N. Y.
- SCHUH, ART
HALE, GORDON*
De Vry Corp.
1111 Armitage Ave.
Chicago 14, Ill.
- SOLOW, S. P.
COHEN, SAMUEL*
Consolidated Film Industries, Inc.
959 Seward St.
Hollywood 28, Calif.
- SPRAY, J. H.
WADE, FRED*
Ace Film Laboratories, Inc.
1277 East 14th St.
Brooklyn 30, N. Y.
- THOMPSON, LLOYD
The Calvin Company
616 West 26th St.
Kansas City 8, Mo.

* Alternate.

SUBCOMMITTEE D ON 16-MM PROJECTION (Z-52)

ZIMMERMAN, A. G., *Chairman*
RCA Victor Division
Radio Corp. of America
501 N. LaSalle St.
Indianapolis 1, Ind.

MAURER, J. A., *Vice-Chairman*
J. A. Maurer, Inc.
117 East 24th St.
New York 10, N. Y.

BARNETT, HERBERT
LORANCE, G. T.*
International Projector Corp.
92 Gold St.
New York 7, N. Y.

CLARK, L. E.
POHL, W. E.*
Technicolor Motion Picture Corp.
6311 Romaine St.
Hollywood 38, Calif.

BERTRAM, E. A.
HOGAN, JOHN*
DeLuxe Laboratories, Inc.
850 Tenth Ave.
New York 19, N. Y.

CONTNER, J. B.
WORRALL, GEORGE*
Cineflex Corp.
305 East 63d St.
New York 21, N. Y.

BRENKERT, KARL
Brenkert Light Projection Corp.
7348 St. Aubin Ave.
Detroit 11, Mich.

DAVEE, L. W.
Century Projector Corp.
729 Seventh Ave.
New York 19, N. Y.

BRETHAUER, F. L.
Bell & Howell Co.
7100 McCormick Rd.
Chicago 45, Ill.

DAVIDSON, J. C.
Electrical Research Products Div.
Western Electric Co.
6601 Romaine St.
Los Angeles 38, Calif.
KEITH, C. R.*
Electrical Research Products Div.
Western Electric Co.
195 Broadway
New York 7, N. Y.

PALMER, M. W.*
Bell & Howell Co.
30 Rockefeller Plaza
New York 20, N. Y.

BUREAU OF SHIPS (Code 350)
Navy Dept.
Washington, D. C.

ELLER, H. E.
WERTHEIMER, A.*
GOLDEN, M. E.*
Radiant Manufacturing Corp.
1140-46 West Superior St.
Chicago 22, Ill.

CARLSON, F. E.
FARNHAM, R. E.*
General Electric Co.
Nela Park
Cleveland 12, Ohio

GOLDSMITH, CAPT. L. T.
NEMEC, LT. BOYCE*
Signal Corps Photographic Center
35-11 35th Ave.
Long Island City 1, N. Y.

CARVER, DR. E. K.
Eastman Kodak Co.
Rochester 4, N. Y.
WHITE, H. E.*
Eastman Kodak Co.
350 Madison Ave.
New York 17, N. Y.

HAMMOND, J. A.
National Carbon Co.
30 East 42d St.
New York 17, N. Y.
GEIB, E. R.*
National Carbon Co.
Box No. 6087
Cleveland 1, Ohio

CHAMBERS, LT. G. A., USNR
Photographic Science Lab.
Naval Air Station
Anacostia, D. C.

* Alternate.

KINGSLAKE, DR. R.

ALTMAN, F.*
Eastman Kodak Co.
Hawk Eye Works
Rochester 4, N. Y.

LESSER, LT. J. L.
Photographic Section
Marine Corps Schools
Quantico, Virginia

LESSLER, L.
ROSENBLUM, JOSEPH*
AnSCO
Binghamton, N. Y.

LOZIER, DR. W. W.
ZAVESKY, R. J.*
National Carbon Co.
Fostoria, Ohio

LYMAN, D. F.
HOOD, H. J.*
Eastman Kodak Co.
333 State St.
Rochester 4, N. Y.

MARTIN, W. S.
FRETLAND, J. D.*
Holmes Projector Corp.
1815 Orchard St.
Chicago 14, Ill.

NEMETH, O. R.
The National Mineral Co.
2638 N. Pulaski Road
Chicago 39, Ill.

KELLMAN, JACK*
The National Mineral Co.
95 Madison Ave.
New York 16, N. Y.

OFFENHAUSER, W. H., JR.
4 West 43d St.
New York 18, N. Y.

HARRIS, SYLVAN*
J. A. Maurer, Inc.
117 East 24th St.
New York 10, N. Y.

PESCE, LT. J. S.
1st Motion Picture Unit
Army Air Forces
88-22 W. Washington Blvd.
Culver City, Calif.

PESTRECOV, DR. K.
Bausch & Lomb Optical Co.
Rochester 2, N. Y.
SCHEICK, J. A.*
Bausch & Lomb Optical Co.
30 Rockefeller Plaza
New York 20, N. Y.

PIERCE, LT. COL. G. McG.
Headquarters
U. S. Marine Corps
Washington 25, D. C.

RAVEN, A. L.
Raven Screen Corp.
314 East 35th St.
New York 16, N. Y.

RESS, T. I.
LEWIS, R. E.*
De Vry Corp.
1111 Armitage Ave.
Chicago 14, Ill.

SACHTLEBEN, L. T.
DREW, R. O.*
RCA Victor Division
Radio Corp. of America
501 N. LaSalle St.
Indianapolis 1, Ind.

SHAPIRO, A.
ROGERS, FRANK, JR.*
Ampro Corp.
2839 N. Western Ave.
Chicago 18, Ill.

STRONG, H. H.
Strong Electric Co.
87 City Park Ave.
Toledo 2, Ohio

VICTOR, A. F.
Victor Animatograph Corp.
Davenport, Iowa

WALKER, R. O.
Walker-American Corp.
801 Beaumont St.
St. Louis, Mo.

WIENKE, E. J.
VAN NIMAN, R. T.*
Motiograph Projector Corp.
4431 W. Lake St.
Chicago 24, Ill.

* Alternate.

SUBCOMMITTEE G ON EXPOSURE METERS (Z-52)

McCUNE, F. K., *Chairman*
General Electric Co.
West Lynn Works
40 Federal St.
West Lynn, Mass.

WHITTENTON, J. M.*
General Electric Co.
Lynn, Mass.

CHAMBERS, LT. G. A., USNR
Photographic Science Lab.
Naval Air Station
Anacostia, D. C.

NEMEC, LT. BOYCE
Signal Corps Photographic Center
35-11 35th Ave.
Long Island City 1, N. Y.

CLARK, D. B.
Research Council of the Academy of
Motion Picture Arts & Sciences
Taft Bldg., Suite 1217
Hollywood 28, Calif.

NORWOOD, CAPT. DON.
1470 San Pasqual St.
Pasadena 4, Calif.

RUSSELL, M. E.
REID, C. D.*
Eastman Kodak Co.
Rochester 4, N. Y.

CONTNER, J. B.
Cineflex Corp.
305 East 63d St.
New York 21, N. Y.
HOLSLAG, R. C.*
J. A. Maurer, Inc.
117 East 24th St.
New York 10, N. Y.

SOUTHER, LT. H. T.
Army Service Forces
Signal Corps Photographic Center
35-11 35th Ave.
Long Island City 1, N. Y.

JACKMAN, F. W.
American Society of Cinematographers,
Inc.
1782 N. Orange Drive
Hollywood 28, Calif.

WEISS, DR. J. P.
WHITE, DR. D. R.*
Redpath Laboratory
E. I. du Pont de Nemours & Co., Inc.
Parlin, N. J.

KUSCHER, J. J.
MACDONALD, DENNISON*
DeJur-Amsco Corp.
Shelton, Conn.

WHITAKER, G. C.
WHITMAN, V. E.*
Folmer Graflex Corp.
154 Clarissa St.
Rochester 8, N. Y.

NELSON, C. N.
Eastman Kodak Co.
Rochester 4, N. Y.

ZOGBAUM, LT. W. M.
Army Service Forces
Signal Corps Photographic Center
35-11 35th Ave.
Long Island City 1, N. Y.

It will be noted that the membership of these Subcommittees is representative of both the engineering and practical authorities for each project under consideration. Every effort was expended to select memberships which could fully contribute to evolution of finished specifications that would provide both the best obtainable process in current circumstances and, if possible, a pronounced improvement in motion picture equipment and accessories.

These Subcommittees are solely task or work committees to accomplish the difficult and tedious job of preparing Standard Speci-

* Alternate.

fications from which Federal Procurement Specifications will be organized by the staff of the American Standards Association. In practically every case, it is necessary for a Subcommittee to make 4 and often more drafts of each detailed set of Standard Performance Specifications before a final draft is acceptable to the Subcommittee, ASA War Committee Z-52, and the Armed Forces. In addition, before final acceptance the final draft is sent to all interested manufacturers, societies, groups, *etc.*, for their comment and criticism. Procedure in this manner minimizes error and breeds general confidence in the end standards.

As before noted, official work on these many projects was begun December 15, 1943, and it is therefore with pride that the following progress can be reported. Subcommittee *D* on 16-mm Projection has approved a final set of Performance Specifications on all 3 projects assigned to it. This was accomplished by having a small group from the full Subcommittee membership prepare an initial draft of specifications in advance of the first two-day meeting held on January 11th and 12th in Cleveland, Ohio. The third draft, and it is believed the final draft, was approved at the two-day meeting held on February 16th and 17th in Rochester, New York. This set of projects was of first priority so the completion of the job within an estimated 90 days from start to finish can be considered exceptional. This means that, if the Armed Services so desire, development contracts can be let as soon as was optimistically expected for a 16-mm Service Model Sound Projector, 16-mm Portable Motion Picture Projection Screens, and 16-mm Visual Test Films.

Following similar procedure, Subcommittee *B* on 16-mm Sound held a one-day meeting on January 13th in Cleveland, Ohio, and held another meeting on March 7th in New York City. At this meeting the Specification for 16-mm Motion Picture Sound Test Films, including exhibition of the contents of most of the types of test sound-track to be included in the sound test film reel, was approved. The sound test film will be in production within 60 days to furnish a steady supply to the Armed Forces and others.

Subcommittee *C* on 16-mm Laboratory Practice held its initial meeting on February 2d and 3d in New York City. The second draft of specifications was reviewed at a meeting on March 8th and 9th in New York City. Within 60 to 90 days, it is expected that a Performance Specification for 16-mm Release Prints will be completed.

Subcommittee *A* on 16-mm Cinematography is now organizing for its initial meeting, and Subcommittee *G* on Exposure Meters held its first meeting on February 24th and 25th in New York City.

The other Subcommittees will hold meetings as rapidly as facilities permit. Each meeting of each committee entails much detailed engineering and clerical work which limits the amount that can be done daily unless unlimited staffs of engineers, draftsmen, and trained secretaries were available.

These projects became possible and are rapidly being completed because of the honesty and coöperative spirit of the War Production Board, members of the Armed Forces, American Standards Association, engineers representing manufacturers of motion picture equipment and film, members of the Society of Motion Picture Engineers, and the Research Council of the Academy of Motion Picture Arts and Sciences. Many new War Standards will result from this work which will be automatically rescinded 6 months after the war. Undoubtedly many of these War Standards, after consideration and approval in the normal accepted channels, will become American Standards even during the war because of desirable necessity. Following the war many will likely be revived as American Standards. This work would seem to advance the 16-mm motion picture industry many years ahead of its time.

DIRECT PROCESSES FOR MAKING PHOTOGRAPHIC PRINTS IN COLOR*,†

C. E. KENNETH MEES**

During the last few years, the public has shown a greatly increased interest in color photography. A few years ago, the introduction of a direct method of making color transparencies made the practice of color photography very much easier than it had been, and at the present time a very large number of photographs are taken in color. Approximately three-quarters of the home motion pictures are made in color, and more than twenty million still pictures are being taken in color this year. I think that if I were to ask the average man in the street, however: "What is the status of color photography?" he would say: "Oh, you can make photographs in color, but we have not yet got real color photography." And if I cross-examined him as to his meaning, I should find that what he was thinking about was the production of prints in color; that he felt that to achieve real "color photography," it should be possible to load a camera with a film and then after the film was developed, to obtain from it a color print, just as a black-and-white print is obtained from an ordinary film exposure.

Color prints are being made, but by processes which involve a great deal of expense and difficulty, and so the objective of real color photography—to make prints in natural colors from a color transparency by some simple, direct process—has remained unattained. Within the past year, however, it has been achieved not by one method but by two different methods. An account of these new processes is given in this paper.

Processes of color photography involve invariably the preparation of three pictures, each taken by one of the primary colors—red, green, and blue-violet—and then their recombination to form the final color

* Communication No. 832 from the Kodak Research Laboratories, Rochester, N. Y., November 27, 1941.

† Reprinted from *Jour. Franklin Institute*, 233, 1 (Jan., 1942), pp. 41-50.

** D.Sc., Director, Research Laboratories, Eastman Kodak Company.

picture. To produce color prints, the pictures are combined in the form of dye images, each of the images being formed of a dye having a color complementary to that by which the picture was taken. The picture taken by red light is printed in a cyan (blue-green) dye, the picture taken by green light is printed in a magenta dye, and the picture taken by blue is printed in a yellow dye. The three separate pictures may be taken successively through suitable filters or simultaneously in a somewhat complicated *one-shot* camera, in which a system of reflectors splits the light from the lens to form three images, or by means of a *tripack*.

The early development of tripacks is dealt with in Chapter IV of E. J. Wall's "History of Three-Color Photography."* He ascribes the first suggestion to Ducos du Hauron, from whom came suggestions for almost all the systems of color photography which have been developed. In 1897, du Hauron described an "Apparatus with a single dark slide and with a single objective procuring the simultaneous obtainment of the three phototypes; in other words, dialytic selection of the light rays by an alternation of color filters and plates or sensitive films, formed like the leaves of a book or polyfolium, placed in the dark slide." In this system a pack of three films and a yellow filter is used. The objection to these tripacks is poor definition. The light passing through the front film becomes diffused, and since this is necessarily separated from the green- and red-sensitive layers by the thickness of the film base, it is difficult to get really sharp pictures. To get the real advantage of a tripack, it is necessary for the three sensitive layers to be almost in contact; that is, the three layers should be coated one over the other so that the distance between the blue and red layers is a small fraction of one-thousandth of an inch. Tripacks of this type were suggested in the early literature of color photography with the idea that they should be separated into the three layers for development and printing, but the manipulation of such systems proved in practice to be very difficult, and they had no success.

It was also suggested, however, that it might be possible to develop such tripacks and then by some chemical treatment to convert the silver images into dye images. There are a number of proposals of this type in the early literature; one of the earliest which appeared possible of realization was that made by Rudolph Fischer in 1912.

* Published by the American Photographic Publishing Company, Boston, Massachusetts.

Fischer proposed that a tripack should be made by coating three emulsions on the top of one another, the lowest one being sensitive to red light, the middle one sensitive to green light, and the top one sensitive to blue light, and that in these three layers there should be incorporated chemical substances which in the process of development would produce dyes. The method which Fischer proposed to use for producing dyes was one which had been discovered by Homolka and worked out by Fischer himself—the process which we now know as *coupler development*.

This depends upon the fact that when a developer reacts with silver bromide and forms silver, its oxidation product as it is formed reacts with other chemical substances in the solution and forms colored compounds; that is, dyes. This is true only of certain developing agents, particularly those known as *diamines*. When the diamines develop silver bromide, their oxidation products formed at the same time combine with many types of chemicals which are known as *couplers* and give rise to strongly colored dyes which are deposited in the film with the silver formed by the development of the image.

The details of the mechanism of dye formation have not been completely established, but it is believed that the first reaction occurs between the developer and exposed silver halide to produce silver. In this reaction, the developer is oxidized to an extremely reactive intermediate product, which immediately reacts with the coupler. This second reaction probably forms the leuco dye, from which the dye itself is generated in a subsequent oxidation step. The choice of developing agents for color-forming development is very limited. All of the known types of organic developers have been investigated, and of these, only certain *p*-phenylenediamine derivatives have been found useful. These consist of *p*-phenylenediamines bearing two substituents on one of the nitrogen atoms. Other substituent groups may be introduced into the benzene nucleus to modify the properties of the developer itself or of the dyes derived from it.

The couplers are distinguished chemically by their possession of a reactive group, usually methylene. The cyan couplers are usually phenols; thus, a typical compound would be a chlorinated naphthol. Magenta couplers are often nitriles or pyrazolones, and the yellow couplers are typically esters, ketones, or amides. The couplers may be added to the developing solution, in which case they must be of relatively low molecular weight and be soluble in the alkaline solution, or they may be incorporated in the emulsion layer. In the Fischer

process, the couplers were incorporated in the layers, each coupler in its appropriate layer, so that during development three different dyes would be produced simultaneously—a cyan dye in the red-sensitized layer; a magenta dye in the green-sensitized layer; and a yellow dye in the layer sensitive to blue and violet. In this process, it was necessary that the sensitizers should not wander from one layer to another and also that the couplers should remain in the layer in which they had been placed. In the existing state of knowledge, Fischer and his collaborators were unable to accomplish this and so were unable to realize his very ingenious process.

The first workers to succeed in producing direct color photographs by a tripack which reached the commercial market were Mannes and Godowsky, to whom the Institute awarded its Edward Longstretch medal in 1940. They adopted coupler development, but instead of putting the coupler into the emulsion, they introduced the dyes into appropriate layers during the processing, the original tripack consisting of the sensitized emulsion layers only. This process was worked out by Mannes and Godowsky in association with the Eastman Kodak Company, and in 1935 it was placed on the market under the name of *Kodachrome*. It was introduced first for 16-mm film for the amateur cinematographer. Since then, its use has been extended to cover the low cost 8-mm motion-picture film, the 35-mm still film for miniature cameras, and cut-sheet film of large size for use by the professional and commercial photographers.

To produce the three color images in Kodachrome, it was necessary to find a method of introducing each dye image into its own layer. The image in the bottom layer, sensitive to red, must be formed of the blue-green dye; the middle layer, of the magenta dye; and the top layer, of the yellow dye. In their original Kodachrome process, Mannes and Godowsky took advantage of the position of the layers. The process uses a film in which there are five coatings: Nearest the base is coated the red-sensitive layer and over this an interlayer of gelatin. Above this is coated a green-sensitive emulsion, which is overcoated with an interlayer of yellow dye to act as a filter. Finally, there is a blue-sensitive emulsion at the top. All the five coatings are very thin, and the total thickness of the emulsion is little more than that used in ordinary film. To transform the three images into the dye positives, the film was first developed to a negative and the negative silver images removed by bleaching with permanganate. The film was then exposed to light to make the positive silver bro-

mide images developable, and the whole film was developed to produce a blue dye in all three layers. Then the film was dried and, in a second machine, was treated with a bleach of low penetration, the action of which was limited to the two top layers, from which the dye was removed and the silver bromide regenerated and developed to a magenta color. The film was dried again, and a bleach of very feeble penetration removed the dye from the top layer and turned the silver in that layer back to silver bromide, so that it might be developed to the yellow dye. This process was slow and very clumsy because of the three separate treatments required, but it was, nevertheless, successful and was operated for some years.

A new process was then worked out in which the assigning of the dyes to their correct layers depends not upon their position in the depth of the film but upon the sensitivity of the three emulsions. It was necessary, of course, that the sensitizers should survive the early stages of processing, and since no sensitizer would withstand the action of acid permanganate, it was necessary to use a different reversal process.

In this process, the exposed film is put through an ordinary developer to produce a silver image. Then the film is exposed through the base to red light, which makes developable the unexposed silver bromide in the bottom layer, and this is developed with a cyan coupler, so that in the bottom layer a positive image in cyan dye is associated with the development of the whole of the silver bromide originally present in the layer. Next, the top side of the film is exposed to blue light and is passed into a developer containing a yellow-forming coupler. Then all the silver bromide is exhausted except that corresponding to the positive image of the middle layer, which is developed with a coupler forming a magenta dye. There are then in the film three positive images in the appropriate colors and the whole of the silver bromide converted into silver by the two development operations which each layer has undergone. The silver is removed from all three layers, and the film is fixed, washed, and dried. This process offered very considerable difficulties when it was first attempted but, in view of its advantages, they were overcome, and it is the method by which the Kodachrome film is now processed.

A great many improvements have been introduced into the original Kodachrome film by changes in the sensitizers, in the couplers, and in the dyes that they produce. The original Kodachrome couplers formed dyes which on long keeping tended to fade, especially at

temperatures above normal. This trouble has been largely eliminated, and unless the present Kodachrome images are exposed to conditions of elevated heat and moisture, they are unlikely to show any appreciable fading over a reasonably long period. The quality of the images has also been improved by steady adjustments of the many points involved until, at the present time, the Kodachrome process may be regarded as a very excellent and reproducible system for obtaining color transparencies.

It is obvious that the Kodachrome process could be used to obtain color prints. If a Kodachrome transparency is laid down on white paper support, it will appear much too dark to make a good print, but a transparency too light and transparent to be satisfactory for viewing by transmitted light can be cemented to a white paper support and the film base removed by solvents, which leaves the color image on the paper. It is also obvious that it should be possible to coat the three sensitive layers on an opaque base, such as paper, and to process them by the Kodachrome process to get a color print, but this is a far more formidable task than would appear. The mere duplicating of a Kodachrome is not very easy. It is difficult to avoid a loss of color saturation and a shift in color. Moreover, the thin coatings on paper give new troubles of their own, and the paper base itself introduces very considerable difficulties. These can be overcome by using a white opaque film base instead of paper.

As a result of a good deal of work, the Eastman Kodak Company was able to announce at the end of August, 1941, that they were prepared to make color prints from Kodachrome transparencies. Three kinds of prints were made available in this program at the beginning of September.

Those known as *Minicolor* prints are made from the small Kodachrome transparencies on 35-mm film which have been so very successful in the hands of the general public. The transparencies are enlarged two diameters to make an inexpensive print or five diameters to make an enlargement which can be placed in a standard photographic mount. Thousands of these 2x and 5x color prints are being made every week. At the same time, commercial prints from larger Kodachrome originals are made by a more complicated process, in which an improved color correction is obtained by the introduction of masks over the original. These masks are black-and-white negatives printed on panchromatic film from the original color transparency. The mask is fastened to the original in accurate register, and,

being a negative, it lowers the over-all contrast of the picture. In addition, the color of the light by which the mask is printed is chosen so that the greens and blues, which tend to become too dark in the print, are lightened. In this way, a print can be made which will reproduce the original much more closely than if no mask were used. These *Kotavachrome* pictures, as they are called, can be made of very large size. Thus, one of the methods for making satisfactory direct color prints utilizes the Kodachrome process.

Some time after the first Kodachrome film was introduced on the market, the Agfa Company in Germany placed on the market a film in which they had realized the original Fischer process. They had available sensitizers and couplers which would not wander from one layer to another and were thus able to put out a film which they processed by a reversal process.

Some years ago, the Kodak Laboratories worked out a modification of the Fischer process in which the couplers in their emulsion layers were not dissolved in the gelatin layer itself but were carried in very small particles of organic materials which would protect them from the gelatin and, at the same time, protect the silver bromide from any interaction with the couplers. When development takes place, the oxidation product of the developing agent dissolves in the organic material and there reacts with the couplers, so that the dyes are formed in the small particles dispersed through the layers. This process might be known technically as the *protected coupler* process. Its success depends upon the choice of suitable materials for protecting the couplers and, of course, upon the choice of suitable coupling compounds for the dyes. During 1941 this process was reduced to a production basis, and early in 1942 a new film was introduced suitable for use in roll-film cameras except those which are already supplied with the 35-mm Kodachrome film. The film is developed as a complementary negative from which prints on paper can be made by the same process. This process has been named *Kodacolor*, a name which was used some years ago for the additive process of color photography by which the first amateur color motion pictures were made. This process is now obsolete, as it was withdrawn when Kodachrome was introduced.

This new Kodacolor process, then, differs very markedly from Kodachrome although it is essentially of the same character. The film is coated with the light-sensitive layers: the red-sensitive layer nearest the base; then the green-sensitive layer; a filter layer; and

the blue-sensitive layer. In each of the emulsion layers are suspended particles of organic compounds insoluble in water, particles so small that they can be seen only under a high power microscope and containing the couplers required to produce the dye appropriate to each layer when they react with the oxidized developer. After exposure, the film is processed with a developer of which the oxidation product reacts with the three couplers, each in its own layer, and thus a dye image is produced with the silver image in each layer. After the silver has been removed, a negative is obtained composed of dyes, in which the image is not only negative as regards light and shade but in which all the colors are complementary to those of the original subject. When such a negative is printed upon a paper coated with a similar set of emulsions containing protected couplers, a color print is obtained in which the colors of the original subject are reproduced.

The Eastman Kodak Company is undertaking to process and print the Kodacolor film. The purchaser of a roll of Kodacolor film can send it to a processing station through his dealer and order color prints from the negatives that will result from his exposures. The prints are made by projection and are of the same width regardless of the size of film used. They are made on a special projection printer adapted to enlarge the picture to a standard width and, at the same time, to maintain the proportions of the picture shape used. In this printing process it is not necessary to use waterproof base, and the prints are on paper. The printing is done on a continuous roll of paper, which is processed through a complicated machine, after which the prints are cut up and delivered.

The introduction of this new process, which makes it possible for the public to obtain color prints without any greater difficulty than attaches to the taking of photographs in black and white, and the development of the Kodachrome printing process, by means of which prints can be obtained from Kodachrome transparencies, mark an important turning point in practical color photography. Just as the introduction of the Kodachrome process in 1935 enabled home motion pictures to be made in color, and in 1937 its application to 35-mm still pictures made it possible for millions of color photographs to be made each year, so these new processes will enable color prints to be produced in rapidly increasing quantities.

It is not always recognized that the development of inventions to the practical stage often involves far more work than the original inventions which made the development possible. The methods used

in the manufacture and processing of Kodachrome were invented long before the film itself could be placed in the hands of the user, and the application of the process to the production of prints required much further work before those prints could be made with sufficient ease and certainty. But, as each new step is taken, new possibilities come into sight and new progress can be made.

The growing popularity of color photography cannot fail to affect the engraving and printing arts. As more and better color photographs are taken, the demand for their reproduction will increase and the use of color in illustration is likely to increase to a very significant extent during the next few years.

OFFICERS AND GOVERNORS OF THE SOCIETY



DONALD E. HYNDMAN
Engineering Vice-President



LOREN L. RYDER
Executive Vice-President



ARTHUR C. DOWNES
Editorial Vice-President



HERBERT GRIFFIN
President

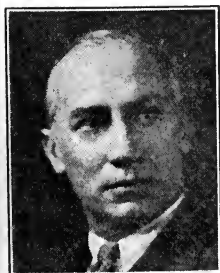

ARTHUR S. DICKINSON
Financial Vice-President



EMERY HUSE
Past-President



WILLIAM C. KUNZMANN
Convention Vice-President



E. ALLAN WILLIFORD
Secretary



M. R. BOYER
Treasurer



FRANK E. CARLSON
Governor



EDWARD M. HONAN
Governor



JOHN A. MAURER
Governor

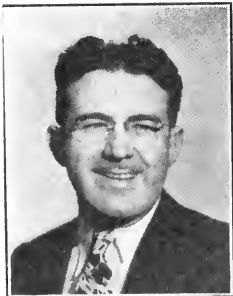

WILLIAM A. MUELLER
Governor



JOSEPH H. SPRAY
Governor



HOLLIS W. MOYSE
Governor



EARL I. SPONABLE
Governor



[H. W. REMERSCHIED
Governor



WALLACE V. WOLFE
Governor



CLYDE R. KEITH
Chairman,
Atlantic Coast Section



REEVE O. STROCK
Governor



CHARLES W. HANDLEY
Chairman,
Pacific Coast Section

ATLANTIC COAST SECTION

CLYDE R. KEITH, *Chairman*

ALFRED N. GOLDSMITH, *Past-Chairman*

M. W. PALMER, *Sec.-Treas.*

E. A. BERTRAM

P. C. GOLDMARK

W. H. OFFENHAUSER, JR.

JAMES FRANK, JR.

J. J. HOPKINS

H. E. WHITE

PACIFIC COAST SECTION

CHARLES W. HANDLEY, *Chairman*

J. G. FRAYNE, *Past-Chairman*

S. P. SOLOW, *Sec.-Treas.*

M. S. LESHING

G. A. SAWYER

W. R. WILKINSON

H. W. MOYSE

C. O. SLYFIELD

W. V. WOLFE

COMMITTEES OF THE SOCIETY

(Correct to March 15th)

Admissions

(East Coast)

A. S. DICKINSON, *Chairman*

M. R. BOYER

JAMES FRANK, JR.

D. E. HYNDMAN

H. D. BRADBURY

GEORGE FRIEDL, JR.

HARRY RUBIN

(West Coast)

EMERY HUSE, *Chairman*

C. W. HANDLEY

W. A. MUELLER

H. W. MOYSE

H. W. REMERSHIED

Board of Editors

A. C. DOWNES, *Chairman*

J. I. CRABTREE

A. M. GUNDELFINGER

C. R. KEITH

A. N. GOLDSMITH

C. W. HANDLEY

E. W. KELLOGG

A. C. HARDY

Cinematography

J. W. BOYLE, *Chairman*

C. G. CLARKE

ARTHUR MILLER

ARTHUR REEVES

KARL FREUND

JOSEPH RUTTENBERG

Color

R. M. EVANS, *Chairman*

F. T. BOWDITCH

A. M. GUNDELFINGER

L. E. CLARK

A. C. HARDY

Convention

W. C. KUNZMANN, *Chairman*

J. G. FRAYNE

SYLVAN HARRIS

O. F. NEU

JULIUS HABER

H. F. HEIDEGGER

R. O. STROCK

Exchange Practice

J. S. MACLEOD, *Chairman*

A. S. DICKINSON

G. K. HADDOW

N. F. OAKLEY

T. FAULKNER

SYLVAN HARRIS

A. W. SCHWALBERG

G. R. GIROUX

L. B. ISAAC

J. SICHELMAN

H. C. KAUFMAN

Fellow MembershipEMERY HUSE, *Chairman*

M. R. BOYER	A. N. GOLDSMITH	W. C. KUNZMANN
A. S. DICKINSON	HERBERT GRIFFIN	L. L. RYDER
A. C. DOWNES	C. W. HANDLEY	E. A. WILLIFORD
	D. E. HYNDMAN	

Historical and MuseumJ. E. ABBOTT, *Chairman*

O. B. DEPUE	RICHARD GRIFFITH	MICHAEL ROBACH
	TERRY RAMSAYE	

Honorary MembershipE. A. WILLIFORD, *Chairman*

J. I. CRABTREE	EMERY HUSE
A. N. GOLDSMITH	L. L. RYDER

Journal AwardSYLVAN HARRIS, *Chairman*

F. G. ALBIN	C. R. KEITH
J. G. FRAYNE	J. A. MAURER

Laboratory PracticeH. E. WHITE, *Chairman*

A. C. BLANEY	G. H. GIBSON	J. M. NICKOLAUS
L. A. BONN	EMERY HUSE	N. F. OAKLEY
A. W. COOK	T. M. INGMAN	W. H. OFFENHAUSER, JR.
O. B. DEPUE	C. L. LOOTENS	V. C. SHANER
R. O. DREW	A. J. MILLER	J. H. SPRAY
J. A. DUBRAY	H. W. MOYSE	J. F. VAN LEUVEN
J. G. FRAYNE		J. R. WILKINSON

Membership and SubscriptionJAMES FRANK, JR., *Chairman*

T. C. BARROWS	E. R. GEIB	H. B. SANTEE
J. G. BRADLEY	SYLVAN HARRIS	G. E. SAWYER
KARL BRENKERT	L. B. ISAAC	W. L. THAYER
L. W. CHASE	W. C. KUNZMANN	C. R. WOOD
J. P. CORCORAN	S. A. LUKES	E. O. WILSCHKE
J. G. FRAYNE	G. E. MATTHEWS	W. V. WOLFE
	W. A. MUELLER	

Non-Theatrical EquipmentJ. A. MAURER, *Chairman*

F. L. BRETHAUER	R. C. HOLSLAG	T. J. RESS
F. E. CARLSON	R. KINGSLAKE	L. T. SACHTLEBEN
JOHN CHRISTIE	D. F. LYMAN	A. SHAPIRO
R. O. DREW	W. H. OFFENHAUSER, JR.	D. G. SMITH
F. M. HALL	M. W. PALMER	M. G. TOWNSLEY
J. A. HAMMOND		A. G. ZIMMERMAN

PapersW. H. OFFENHAUSER, JR., *Chairman*C. R. DAILY, *Vice-Chairman*

F. T. BOWDITCH	JAMES FRANK, JR.	H. W. MOYSE
G. A. CHAMBERS	J. G. FRAYNE	V. C. SHANER
F. L. EICH	C. R. KEITH	S. P. SOLOW
R. E. FARNHAM	E. W. KELLOGG	D. R. WHITE
J. L. FORREST	G. E. MATTHEWS	W. V. WOLFE
	P. A. MCGUIRE	

Preservation of FilmJ. G. BRADLEY, *Chairman*

J. E. ABBOTT	J. L. FORREST	W. F. KELLEY
J. I. CRABTREE	C. L. GREGORY	TERRY RAMSAYE
A. S. DICKINSON		V. B. SEASE

Process PhotographyWILLIAM THOMAS, *Chairman*

F. R. ABBOTT	F. M. FALGE	GROVER LAUBE
A. H. BOLT	C. W. HANDLEY	G. H. WORRALL
	W. C. HOCH	

ProgressG. A. CHAMBERS, *Chairman*

F. T. BOWDITCH	J. A. DUBRAY	G. E. MATTHEWS
G. L. DIMMICK	M. S. LESHING	D. R. WHITE

Progress Medal AwardJ. I. CRABTREE, *Chairman*

O. B. DEPUE	J. A. MAURER
G. E. MATTHEWS	L. L. RYDER

PublicityJULIUS HABER, *Chairman*G. A. CHAMBERS
C. R. DAILY

HAROLD DESFOR

G. R. GIROUX
P. A. MCGUIRE**Sound**W. V. WOLFE, *Chairman*C. R. KEITH, *Vice-Chairman*M. C. BATSEL
D. J. BLOOMBERG
B. B. BROWN
F. E. CAHILL, JR.
C. R. DAILY
L. T. GOLDSMITHE. H. HANSEN
L. B. ISAAC
G. T. LORANCE
J. A. MAURER
W. C. MILLER
K. F. MORGANW. A. MUELLER
HARRY RUBIN
G. E. SAWYER
S. P. SOLOW
F. R. WILSON
E. C. ZRENNER**Standards**F. T. BOWDITCH, *Chairman*J. M. ANDREAS
P. H. ARNOLD
HERBERT BARNETT
M. C. BATSEL
M. R. BOYER
F. E. CARLSON
T. H. CARPENTER
E. K. CARVER
H. B. CUTHBERTSON
L. W. DAVEE
J. A. DUBRAYA. F. EDOUARD
J. L. FORREST
A. N. GOLDSMITH
L. T. GOLDSMITH
HERBERT GRIFFIN
A. C. HARDY
D. B. JOY
C. R. KEITH
P. J. LARSEN
R. G. LINDERMAN
C. L. LOOTENSJ. A. MAURER
G. A. MITCHELL
W. H. OFFENHAUSER, JR.
G. F. RACKETT
W. B. RAYTON
HARRY RUBIN
OTTO SANDVIK
LLOYD THOMPSON
J. F. VAN LEUVEN
H. E. WHITE
A. G. ZIMMERMAN**Studio Lighting**C. W. HANDLEY, *Chairman*J. W. BOYLE
H. J. CHANON

R. E. FARNHAM

KARL FREUND
W. W. LOZIER**Television**P. C. GOLDMARK, *Chairman*R. B. AUSTRIAN
H. S. BAMFORD
R. L. CAMPBELL
E. D. COOK
C. E. DEAN
A. N. GOLDSMITH
T. T. GOLDSMITHHERBERT GRIFFIN
C. F. HORSTMAN
L. B. ISAAC
A. G. JENSEN
P. J. LARSEN
H. R. LUBCKE
I. G. MALOFF
J. A. MAURERPIERRE MERTZ
PAUL RAIBURN
P. H. REEDY
OTTO SANDVIK
R. E. SHELBY
E. I. SPONABLE
H. E. WHITE

Test Film Quality

F. R. WILSON

C. F. HORSTMAN

Theater EngineeringA. N. GOLDSMITH, *Chairman***Subcommittee on Projection Practice**L. B. ISAAC, *Chairman*

(Under organization)

Subcommittee on Screen BrightnessF. E. CARLSON *Chairman*

HERBERT BARNETT

W. F. LITTLE

C. M. TUTTLE

E. R. GEIB

W. B. RAYTON

H. E. WHITE

SYLVAN HARRIS

A. T. WILLIAMS

Subcommittee on Theater Engineering, Construction and Operation

(Under organization)

SMPE REPRESENTATIVES TO OTHER ORGANIZATIONS*American Documentation Institute*

J. E. ABBOTT

*American Standards Association:**Sectional Committee on Motion Pictures, Z22*

E. K. CARVER

A. N. GOLDSMITH

E. A. WILLIFORD

Sectional Committee on Photography, Z38

J. I. CRABTREE

*Sectional Committee on Standardization of Letter Symbols
and Abbreviations for Science and Engineering, Z10*

L. A. JONES

*Inter-Society Color Council*R. M. EVANS, *Chm.*

J. A. BALL

F. T. BOWDITCH

J. G. CAPSTAFF

G. F. RACKETT

Radio Technical Planning Board

P. J. LARSEN

E. I. SPONABLE*

* Alternate.

*American Standards Association
Sectional Committee on Motion Pictures, Z22*

A. N. GOLDSMITH, *Chairman*

C. R. KEITH, *Secretary*

K. F. ABEEL	E. W. ELY	N. F. OAKLEY
P. H. ARNOLD	R. E. FARNHAM	* (M. R. BOYER)
M. C. BATSEL	HERBERT GRIFFIN	DAVID PALFREYMAN
B. H. CARROLL	D. B. JOY	OTTO SANDVIK
E. K. CARVER	* (E. A. WILLIFORD)	* (M. E. RUSSELL)
KENNETH CLARK	W. F. KELLEY	A. R. SMALL
WALTER CLARK	G. A. MITCHELL	* (G. W. BOOTH)
A. S. DICKINSON	* (JOSEPH RUTTENBERG)	K. F. SPACE
J. A. DUBRAY	T. T. MOULTON	J. L. SPENCE
A. F. EDOUART	O. F. NEU	G. H. WORRALL

* Alternate.

CONSTITUTION AND BY-LAWS
OF THE
SOCIETY OF MOTION PICTURE ENGINEERS*

CONSTITUTION

Article I

Name

The name of this association shall be SOCIETY OF MOTION PICTURE ENGINEERS.

Article II

Object

Its objects shall be: Advancement in the theory and practice of motion picture engineering and the allied arts and sciences, the standardization of the equipment, mechanisms, and practices employed therein, the maintenance of a high professional standing among its members, and the dissemination of scientific knowledge by publication.

Article III

Eligibility

Any person of good character may be a member in any grade for which he is eligible.

Article IV

Officers

The officers of the Society shall be a President, a Past-President, an Executive Vice-President, an Engineering Vice-President, an Editorial Vice-President, a Financial Vice-President, a Convention Vice-President, a Secretary, and a Treasurer.

The term of office of the President, the Past-President, the Executive Vice-President, the Engineering Vice-President, the Editorial Vice-President, the Financial Vice-President, and the Convention Vice-President shall be two years, and the Secretary and the Treasurer one year. Of the Engineering, Editorial, Financial, and Convention Vice-Presidents, two shall be elected alternately each year, or until their successors are chosen. The President shall not be immediately eligible to succeed himself in office.

Article V

Board of Governors

The Board of Governors shall consist of the President, the Past-President, the five Vice-Presidents, the Secretary, the Treasurer, the Section Chairmen and

* Corrected to March 15, 1944.

ten elected governors. Five of these governors shall be resident in the area operating under Pacific and Mountain time, and five of the governors shall be resident in the area operating under Central and Eastern time. Two of the governors from the Pacific area and three of the governors from the Eastern area shall be elected in the odd-numbered years, and three of the governors in the Pacific area and two of the governors in the Eastern area shall be elected in the even-numbered years. The term of office of all elected governors shall be for a period of two years.

Article VI

Meetings

There shall be an annual meeting, and such other meetings as stated in the By-Laws.

Article VII

Amendments

This Constitution may be amended as follows: Amendments shall be approved by the Board of Governors, and shall be submitted for discussion at any regular members' meeting. The proposed amendment and complete discussion then shall be submitted to the entire Active, Fellow, and Honorary membership, together with letter ballot as soon as possible after the meeting. Two-thirds of the vote cast within sixty days after mailing shall be required to carry the amendment.

BY-LAWS

By-Law I

Membership

Sec. 1.—The membership of the Society shall consist of Honorary members, Fellows, Active members, Associate members, Student members, and Sustaining members.

An **Honorary member** is one who has performed eminent services in the advancement of motion picture engineering or in the allied arts. An Honorary member shall be entitled to vote and to hold any office in the Society.

A **Fellow** is one who shall not be less than thirty years of age and who shall comply with the requirements of either (a) or (b) for Active members and, in addition, shall by his proficiency and contributions have attained to an outstanding rank among engineers or executives of the motion picture industry. A Fellow shall be entitled to vote and to hold any office in the Society.

An **Active member** is one who shall be not less than 25 years of age, and shall be (a) a motion picture engineer by profession. He shall have been engaged in the practice of his profession for a period of at least three years, and shall have taken responsibility for the design, installation, or operation of systems or apparatus pertaining to the motion picture industry; (b) a person regularly employed in motion picture or closely allied work, who by his inventions or proficiency in motion picture science or as an executive of a motion picture enterprise of large scope, has attained to a recognized standing in the motion picture industry.

In case of such an executive, the applicant must be qualified to take full charge of the broader features of motion picture engineering involved in the work under his direction.

An **Active member** is privileged to vote and to hold any office in the Society.

An **Associate member** is one who shall be not less than 18 years of age, and shall be a person who is interested in or connected with the study of motion picture technical problems or the application of them. An Associate member is not privileged to vote, to hold office or to act as chairman of any committee, although he may serve upon any committee to which he may be appointed; and, when so appointed, shall be entitled to the full voting privileges of a committee member.

A **Student member** is any person registered as a student, graduate or undergraduate, in a college, university, or educational institution, pursuing a course of studies in science or engineering that evidences interest in motion picture technology. Membership in this grade shall not extend more than one year beyond the termination of the student status described above. A Student member shall have the same privileges as an Associate member of the Society.

A **Sustaining member** is an individual, a firm, or corporation contributing substantially to the financial support of the Society.

Sec. 2.—All applications for membership or transfer, except for Honorary or Fellow membership, shall be made on blank forms provided for the purpose, and shall give a complete record of the applicant's education and experience. Honorary and Fellow membership may not be applied for.

Sec. 3.—(a) **Honorary membership** may be granted upon recommendation of the Board of Governors when confirmed by a four-fifths majority vote of the Honorary members, Fellows, and Active members present at any regular meeting of the Society. An Honorary member shall be exempt from all dues.

(b) **Fellow membership** may be granted upon recommendation of the Fellow Membership Award Committee, when confirmed by a three-fourths majority vote of the Board of Governors.

(c) Applicants for **Active membership** shall give as reference at least three members of Active or of higher grade in good standing. Applicants shall be elected to membership by the unanimous approval of the entire membership of the appropriate Admissions Committee. In the event of a single dissenting vote or failure of any member of the Admissions Committee to vote, the application shall be referred to the Board of Governors, in which case approval of at least three-fourths of the Board of Governors shall be required.

(d) Applicants for **Associate membership** shall give as reference at least one member of higher grade in good standing. Applicants shall be elected to membership by approval of a majority of the appropriate Admissions Committee.

(e) Applicants for **Student membership** shall give as reference the head of the department of the institution he is attending, this faculty member not necessarily being a member of the Society.

By-Law II

Officers

Sec. 1.—An officer or governor shall be an Honorary, a Fellow, or an Active member.

Sec. 2.—Vacancies in the Board of Governors shall be filled by the Board of Governors until the annual meeting of the Society.

By-Law III

Board of Governors

Sec. 1.—The Board of Governors shall transact the business of the Society between members' meetings, and shall meet at the call of the President, with the proviso that no meeting shall be called without at least seven (7) days' prior notice, stating the purpose of the meeting, to all members of the Board by letter or by telegram.

Sec. 2.—Nine members of the Board of Governors shall constitute a quorum at all meetings.

Sec. 3.—When voting by letter ballot, a majority affirmative vote of the total membership of the Board of Governors shall carry approval, except as otherwise provided.

Sec. 4.—The Board of Governors, when making nominations to office, and to the Board, shall endeavor to nominate persons, who in the aggregate are representative of the various branches or organizations of the motion picture industry to the end that there shall be no substantial predominance upon the Board, as the result of its own action, of representatives of any one or more branches or organizations of the industry.

By-Law IV

Committees

Sec. 1.—All committees, except as otherwise specified, shall be appointed by the President.

Sec. 2.—All committees shall be appointed to act for the term served by the officer who shall appoint the committees, unless their appointment is sooner terminated by the appointing officer.

Sec. 3.—Chairmen of the committees shall not be eligible to serve in such capacity for more than two consecutive terms.

Sec. 4.—Standing committees of the Society shall be as follows to be appointed as designated:

(a) *Appointed by the President and confirmed by the Board of Governors—*

- Progress Medal Award Committee
- Journal Award Committee
- Honorary Membership Committee
- Fellow Membership Award Committee
- Admissions Committees
 - (Atlantic Coast Section)
 - (Pacific Coast Section)
- European Advisory Committee

(b) *Appointed by the Engineering Vice-President—*

- Sound Committee
- Standards Committee

Studio Lighting Committee
 Color Committee
 Theater Engineering Committee
 Exchange Practice Committee
 Non-Theatrical Equipment Committee
 Television Committee
 Test-Film Quality Committee
 Laboratory Practice Committee
 Cinematography Committee
 Process Photography Committee
 Preservation of Film Committee

- (c) *Appointed by the Editorial Vice-President*—
 Board of Editors
 Papers Committee
 Progress Committee
 Historical Committee
 Museum Committee
- (d) *Appointed by the Convention Vice-President*—
 Publicity Committee
 Convention Arrangements Committee
 Apparatus Exhibit Committee
- (e) *Appointed by the Financial Vice-President*—
 Membership and Subscription Committee

Sec. 5.—Two Admissions Committees, one for the Atlantic Coast Section and one for the Pacific Coast Section, shall be appointed. The former Committee shall consist of a Chairman and six Fellow or Active members of the Society residing in the metropolitan area of New York, of whom at least four shall be members of the Board of Governors.

The latter Committee shall consist of a Chairman and four Fellow or Active members of the Society residing in the Pacific Coast area, of whom at least three shall be members of the Board of Governors.

By-Law V

Meetings

Sec. 1.—The location of each meeting of the Society shall be determined by the Board of Governors.

Sec. 2.—Only Honorary members, Fellows, and Active members shall be entitled to vote.

Sec. 3.—A quorum of the Society shall consist in number of one-tenth of the total number of Honorary members, Fellows, and Active members as listed in the Society's records at the close of the last fiscal year.

Sec. 4.—The fall convention shall be the annual meeting.

Sec. 5.—Special meetings may be called by the President and upon the request of any three members of the Board of Governors not including the President.

Sec. 6.—All members of the Society in any grade shall have the privilege of discussing technical material presented before the Society or its Sections.

By-Law VI

Duties of Officers

Sec. 1.—The **President** shall preside at all business meetings of the Society and shall perform the duties pertaining to that office. As such he shall be the chief executive of the Society, to whom all other officers shall report.

Sec. 2.—In the absence of the President, the officer next in order as listed in Article IV of the Constitution shall preside at meetings and perform the duties of the President.

Sec. 3.—The five Vice-Presidents shall perform the duties separately enumerated below for each office, or as defined by the President:

(a) The **Executive Vice-President** shall represent the President in such geographical areas of the United States as shall be determined by the Board of Governors, and shall be responsible for the supervision of the general affairs of the Society in such areas, as directed by the President of the Society.

(b) The **Engineering Vice-President** shall appoint all technical committees. He shall be responsible for the general initiation, supervision, and coordination of the work in and among these committees. He may act as Chairman of any committee or otherwise be a member ex-officio.

(c) The **Editorial Vice-President** shall be responsible for the publication of the Society's JOURNAL and all other technical publications. He shall pass upon the suitability of the material for publication, and shall cause material suitable for publication to be solicited as may be needed. He shall appoint a Papers Committee and an Editorial Committee. He may act as Chairman of any committee or otherwise be a member ex-officio.

(d) The **Financial Vice-President** shall be responsible for the financial operations of the Society, and shall conduct them in accordance with budgets approved by the Board of Governors. He shall study the costs of operation and the income possibilities to the end that the greatest service may be rendered to the members of the Society within the available funds. He shall submit proposed budgets to the Board. He shall appoint at his discretion a Ways and Means Committee, a Membership Committee, a Commercial Advertising Committee, and such other committees within the scope of his work as may be needed. He may act as Chairman of any of these committees or otherwise be a member ex-officio.

(e) The **Convention Vice-President** shall be responsible for the national conventions of the Society. He shall appoint a Convention Arrangements Committee, an Apparatus Exhibit Committee, and a Publicity Committee. He may act as Chairman of any committee, or otherwise be a member ex-officio.

Sec. 4.—The **Secretary** shall keep a record of all meetings; he shall conduct the correspondence relating to his office, and shall have the care and custody of records, and the seal of the Society.

Sec. 5.—The **Treasurer** shall have charge of the funds of the Society and disburse them as and when authorized by the Financial Vice-President. He shall make an annual report, duly audited, to the Society, and a report at such other

times as may be requested. He shall be bonded in an amount to be determined by the Board of Governors and his bond filed with the Secretary.

Sec. 6.—Each officer of the Society, upon the expiration of his term of office, shall transmit to his successor a memorandum outlining the duties and policies of his office.

By-Law VII

Elections

Sec. 1.—All officers and governors shall be elected to their respective offices by a majority of ballots cast by the Active, Fellow, and Honorary members in the following manner:

Not less than three months prior to the annual fall convention, the Board of Governors shall nominate for each vacancy several suitable candidates. Nominations shall first be presented by a Nominating Committee appointed by the President, consisting of nine members, including a Chairman. The committee shall be made up of two Past-Presidents, three members of the Board of Governors not up for election, and four other Active, Fellow, or Honorary members, not currently officers or governors of the Society. Nominations shall be made by three-quarters affirmative vote of the total Nominating Committee. Such nominations shall be final unless any nominee is rejected by a three-quarters vote of the Board of Governors present and voting.

The Secretary shall then notify these candidates of their nomination. From the list of acceptances, not more than two names for each vacancy shall be selected by the Board of Governors and placed on a letter ballot. A blank space shall be provided on this letter ballot under each office, in which space the names of any Active, Fellow, or Honorary members other than those suggested by the Board of Governors may be voted for. The balloting shall then take place.

The ballot shall be enclosed in a blank envelope which is enclosed in an outer envelope bearing the Secretary's address and a space for the member's name and address. One of these shall be mailed to each Active, Fellow, and Honorary member of the Society, not less than forty days in advance of the annual fall convention.

The voter shall then indicate on the ballot one choice for each office, seal the ballot in the blank envelope, place this in the envelope addressed to the Secretary, sign his name and address on the latter, and mail it in accordance with the instructions printed on the ballot. No marks of any kind except those above prescribed shall be placed upon the ballots or envelopes.

The sealed envelope shall be delivered by the Secretary to a Committee of Tellers appointed by the President at the annual fall convention. This committee shall then examine the return envelopes, open and count the ballots, and announce the results of the election.

The newly elected officers and governors of the general Society shall take office on January 1st following their election.

By-Law VIII

Dues and Indebtedness

Sec. 1.—The annual dues shall be fifteen dollars (\$15) for Fellows and Active members, seven dollars and fifty cents (\$7.50) for Associate members, and three

dollars (\$3.00) for Student members, payable on or before January 1st of each year. Current or first year's dues for new members in any calendar year shall be at the full annual rate for those notified of acceptance in the Society on or before June 30th; one-half the annual rate for those notified of acceptance in the Society on or after July 1st.

Sec. 2.—(a) Transfer of membership to a higher grade may be made at any time. If the transfer is made on or before June 30th the annual dues of the higher grade is required. If the transfer is made on or after July 1st and the member's dues for the full year has been paid, one-half of the annual dues of the higher grade is payable less one-half the annual dues of the lower grade.

(b) No credit shall be given for annual dues in a membership transfer from a higher to a lower grade, and such transfers shall take place on January 1st of each year.

(c) The Board of Governors upon their own initiative and without a transfer application may elect, by the approval of at least three-fourths of the Board, any Associate or Active member for transfer to any higher grade of membership.

*Sec. 3.—*Annual dues shall be paid in advance. All Honorary members, Fellows, and Active members in good standing, as defined in Section 5, may vote or otherwise participate in the meetings.

*Sec. 4.—*Members shall be considered delinquent whose annual dues for the year remain unpaid on February 1st. The first notice of delinquency shall be mailed February 1st. The second notice of delinquency shall be mailed, if necessary, on March 1st, and shall include a statement that the member's name will be removed from the mailing list for the JOURNAL and other publications of the Society before the mailing of the April issue of the JOURNAL. Members who are in arrears of dues on June 1st, after two notices of such delinquency have been mailed to their last address of record, shall be notified their names have been removed from the mailing list and shall be warned unless remittance is received on or before August 1st, their names shall be submitted to the Board of Governors for action at the next meeting. Back issues of the JOURNAL shall be sent, if available, to members whose dues have been paid prior to August 1st.

Sec. 5.—(a) Members whose dues remain unpaid on October 1st may be dropped from the rolls of the Society by majority vote and action of the Board, or the Board may take such action as it sees fit.

(b) Anyone who has been dropped from the rolls of the Society for non-payment of dues shall, in the event of his application for reinstatement, be considered as a new member.

(c) Any member may be suspended or expelled for cause by a majority vote of the entire Board of Governors; provided he shall be given notice and a copy in writing of the charges preferred against him, and shall be afforded opportunity to be heard ten days prior to such action.

*Sec. 6.—*The provisions of Sections 1 to 4, inclusive, of this By-Law VIII given above may be modified or rescinded by action of the Board of Governors.

By-Law IX

Emblem

*Sec. 1.—*The emblem of the Society shall be a facsimile of a four-hole film-reel with the letter S in the upper center opening, and the letters M, P, and E, in the

three lower openings, respectively. The Society's emblem may be worn by members only.

By-Law X

Publications

Sec. 1.—Papers read at meetings or submitted at other times, and all material of general interest shall be submitted to the Editorial Board, and those deemed worthy of permanent record shall be printed in the JOURNAL. A copy of each issue shall be mailed to each member in good standing to his last address of record. Extra copies of the JOURNAL shall be printed for general distribution and may be obtained from the General Office on payment of a fee fixed by the Board of Governors.

By-Law XI

Local Sections

Sec. 1.—Sections of the Society may be authorized in any state or locality where the Active, Fellow, and Honorary membership exceeds 20. The geographic boundaries of each Section shall be determined by the Board of Governors.

Upon written petition, signed by 20 or more Active members, Fellows, and Honorary members, for the authorization of a Section of the Society, the Board of Governors may grant such authorization.

Section Membership

Sec. 2.—All members of the Society of Motion Picture Engineers in good standing residing in that portion of any country set apart by the Board of Governors tributary to any local Section shall be eligible for membership in that Section, and when so enrolled they shall be entitled to all privileges that such local Section may, under the General Society's Constitution and By-Laws, provide.

Any member of the Society in good standing shall be eligible for non-resident affiliated membership of any Section under conditions and obligations prescribed for the Section. An affiliated member shall receive all notices and publications of the Section but he shall not be entitled to vote at Sectional Meetings.

Sec. 3.—Should the enrolled Active, Fellow, and Honorary membership of a Section fall below 20, or should the technical quality of the presented papers fall below an acceptable level, or the average attendance at meetings not warrant the expense of maintaining the organization, the Board of Governors may cancel its authorization.

Section Officers

Sec. 4.—The officers of each Section shall be a Chairman and a Secretary-Treasurer. The Section chairmen shall automatically become members of the Board of Governors of the General Society, and continue in such positions for the duration of their terms as chairmen of the local Sections. Each Section officer shall hold office for one year, or until his successor is chosen.

Section Board of Managers

Sec. 5.—The Board of Managers shall consist of the Section Chairman, the Section Past-Chairman, the Section Secretary-Treasurer, and six Active, Fellow, or

Honorary members. Each manager of a Section shall hold office for two years, or until his successor is chosen.

Section Elections

Sec. 6.—The officers and managers of a Section shall be Active, Fellow, or Honorary members of the General Society.

Not less than three months prior to the annual fall convention of the Society, nominations shall be presented to the Board of Managers of the Section by a Nominating Committee appointed by the Chairman of the Section, consisting of seven members, including a chairman. The Committee shall be composed of the present Chairman, the Past-Chairman, two other members of the Board of Managers not up for election, and three other Active, Fellow, or Honorary members of the Section not currently officers or managers of the Section. Nominations shall be made by a three-quarters affirmative vote of the total Nominating Committee. Such nominations shall be final, unless any nominee is rejected by a three-quarters vote of the Board of Managers, and in the event of such rejection the Board of Managers will make its own nomination.

The Chairman of the Section shall then notify these candidates of their nomination. From the list of acceptances, not more than two names for each vacancy shall be selected by the Board of Managers and placed on a letter ballot. A blank space shall be provided on this letter ballot under each office, in which space the names of any Active, Fellow, or Honorary members other than those suggested by the Board of Managers may be voted for. The balloting shall then take place.

The ballot shall be enclosed in a blank envelope which is enclosed in an outer envelope bearing the local Secretary-Treasurer's address and a space for the member's name and address. One of these shall be mailed to each Active, Fellow, and Honorary member of the Society residing in the geographical area covered by the Section, not less than forty days in advance of the annual fall convention.

The voter shall then indicate on the ballot one choice for each office, seal the ballot in the blank envelope, place this in the envelope addressed to the Secretary-Treasurer, sign his name and address on the latter, and mail it in accordance with the instructions printed on the ballot. No marks of any kind except those above prescribed shall be placed upon the ballots or envelopes.

The sealed envelopes shall be delivered by the Secretary-Treasurer to his Board of Managers at a duly called meeting. The Board of Managers shall then examine the return envelopes, open and count the ballots, and announce the results of the election.

The newly elected officers and managers shall take office on January 1st following their election.

Section Business

Sec. 7.—The business of a Section shall be conducted by the Board of Managers.

Section Expenses

Sec. 8.—(a) As early as possible in the fiscal year, the Secretary-Treasurer of each Section shall submit to the Board of Governors of the Society a budget of expenses for the year.

(b) The Treasurer of the General Society may deposit with each Section Secre-

tary-Treasurer a sum of money, the amount to be fixed by the Board of Governors, for current expenses.

(c) The Secretary-Treasurer of each Section shall send to the Treasurer of the General Society, quarterly or on demand, an itemized account of all expenditures incurred during the preceding interval.

(d) Expenses other than those enumerated in the budget, as approved by the Board of Governors of the General Society, shall not be payable from the general funds of the Society without express permission from the Board of Governors.

(e) A Section Board of Managers shall defray all expenses of the Section not provided for by the Board of Governors, from funds raised locally by donation, or fixed annual dues, or by both.

(f) The Secretary of the General Society shall, unless otherwise arranged, supply to each Section all stationery and printing necessary for the conduct of its business.

Section Meetings

Sec. 9.—The regular meetings of a Section shall be held in such places and at such hours as the Board of Managers may designate.

The Secretary-Treasurer of each Section shall forward to the Secretary of the General Society, not later than five days after a meeting of a Section, a statement of the attendance and of the business transacted.

Section Papers

Sec. 10.—Papers shall be approved by the Section's Papers Committee previously to their being presented before a Section. Manuscripts of papers presented before a Section, together with a report of the discussions and the proceedings of the Section meetings, shall be forwarded promptly by the Section Secretary-Treasurer to the Secretary of the General Society. Such material may, at the discretion of the Board of Editors of the General Society, be printed in the Society's publications.

Constitution and By-Laws

Sec. 11.—Sections shall abide by the Constitution and By-Laws of the Society and conform to the regulations of the Board of Governors. The conduct of Sections shall always be in conformity with the general policy of the Society as fixed by the Board of Governors.

By-Law XII

Amendments

Sec. 1.—These By-Laws may be amended at any regular meeting of the Society by the affirmative vote of two-thirds of the members present at a meeting who are eligible to vote thereon, a quorum being present, either on the recommendation of the Board of Governors or by a recommendation to the Board of Governors signed by any ten members of Active or higher grade, provided that the proposed amendment or amendments shall have been published in the *JOURNAL* of the Society, in the issue next preceding the date of the stated business meeting of the Society at which the amendment or amendments are to be acted upon.

Sec. 2.—In the event that no quorum of the voting members is present at the time of the meeting referred to in *Section 1*, the amendment or amendments shall

be referred for action to the Board of Governors. The proposed amendment or amendments then become a part of the By-Laws upon receiving the affirmative vote of three-quarters of the Board of Governors.

JOURNAL AWARD AND PROGRESS MEDAL AWARD

In accordance with the provisions of the Administrative Practices of the Society, the regulations of procedure for the Journal Award and the Progress Medal Award, a list of the names of previous recipients, and the reasons therefor, shall be published annually in the JOURNAL, as follows:

JOURNAL AWARD

The Journal Award Committee shall consist of five Fellows or Active members of the Society, appointed by the President and confirmed by the Board of Governors. The Chairman of the Committee shall be designated by the President.

At the fall convention of the Society a Journal Award Certificate shall be presented to the author or to each of the authors of the most outstanding paper originally published in the JOURNAL of the Society during the preceding calendar year.

Other papers published in the JOURNAL of the Society may be cited for honorable mention, at the option of the Committee, but in any case should not exceed five in number.

The Journal Award shall be made on the basis of the following qualifications:

(1) The author, or in the event of multiple authors, at least one of the co-authors, shall be a member of the Society—(any grade). All co-authors shall receive Journal Award Certificates.

(2) The paper must deal with some technical phase of motion picture engineering.

(3) No paper given in connection with the receipt of any other Award of the Society shall be eligible.

(4) In judging of the merits of the paper, three qualities shall be considered, with the weights here indicated:

- | | |
|---|--------------|
| (a) Excellence of presentation of the material..... | 50 per cent. |
| (b) Originality and breadth of interest..... | 30 per cent. |
| (c) Technical merit and importance of material..... | 20 per cent. |

A majority vote of the entire Committee shall be required for the election to the Award. Absent members may vote in writing.

The report of the Committee shall be presented to the Board of Governors at their July meeting for ratification.

These regulations, a list of the names of those who have previously received the Journal Award, the year of each Award, and the titles of the papers shall be published annually in the April issue of the JOURNAL of the Society. In addition, the list of papers selected for honorable mention shall be published in the JOURNAL of the Society during the year current with the Award.

The Awards in previous years have been as follows:

1934—P. A. Snell, for his paper entitled "An Introduction to the Experimental Study of Visual Fatigue." (Published May, 1933.)

1935—L. A. Jones and J. H. Webb, for their paper entitled "Reciprocity Law Failure in Photographic Exposure." (Published Sept., 1934.)

1936—E. W. Kellogg, for his paper entitled "A Comparison of Variable-Density and Variable-Width Systems." (Published Sept., 1935.)

1937—D. B. Judd, for his paper entitled "Color Blindness and Anomalies of Vision." (Published June, 1936.)

1938—K. S. Gibson, for his paper entitled "The Analysis and Specification of Color." (Published Apr., 1937.)

1939—H. T. Kalmus, for his paper entitled "Technicolor Adventures in Cinemaland." (Published Dec., 1938.)

1940—R. R. McNath, for his paper entitled "The Surface of the Nearest Star." (Published Mar., 1939.)

1941—J. G. Frayne and Vincent Pagliarulo, for their paper entitled "The Effects of Ultraviolet Light on Variable-Density Recording and Printing." (Published June, 1940.)

1942—W. J. Albersheim and Donald MacKenzie, for their paper entitled "Analysis of Sound-Film Drives." (Published July, 1941.)

1943—No Award made.

The present Chairman of the Journal Award Committee is Sylvan Harris.

PROGRESS MEDAL AWARD

The Progress Medal Award Committee shall consist of five Fellows or Active members of the Society, appointed by the President and confirmed by the Board of Governors. The Chairman of the Committee shall be designated by the President.

The Progress Medal may be awarded each year to an individual in recognition of any invention, research, or development which, in the opinion of the Committee, shall have resulted in a significant advance in the development of motion picture technology.

Any member of the Society may recommend persons deemed worthy of the Award. The recommendation in each case shall be in writing and in detail as to the accomplishments which are thought to justify consideration. The recommendation shall be seconded in writing by any two Fellows or Active members of the Society, who shall set forth their knowledge of the accomplishments of the candidate which, in their opinion, justify consideration.

A majority vote of the entire Committee shall be required to constitute an Award of the Progress Medal. Absent members may vote in writing.

The report of the Committee shall be presented to the Board of Governors at their July meeting for ratification.

The recipient of the Progress Medal shall be asked to present a photograph of himself to the Society and, at the discretion of the Committee, may be asked to prepare a paper for publication in the JOURNAL of the Society.

These regulations, a list of the names of those who have previously received the Medal, the year of each Award, and a statement of the reason for the Award shall be published annually in the April issue of the JOURNAL of the Society.

Previous Awards have been as follows:

The 1935 Award was made to E. C. Wentz, for his work in the field of sound recording and reproduction. (Citation published Dec., 1935.)

The 1936 Award was made to C. E. K. Mees, for his work in photography. (Citation published Dec., 1936.)

The 1937 Award was made to E. W. Kellogg, for his work in the field of sound reproduction. (Citation published Dec., 1937.)

The 1938 Award was made to H. T. Kalmus, for his work in developing color motion pictures. (Citation published Dec., 1938.)

The 1939 Award was made to L. A. Jones, for his scientific researches in the field of photography. (Citation published Dec., 1939.)

The 1940 Award was made to Walt Disney, for his contributions to motion picture photography and sound recording of feature and short cartoon films. (Citation published Dec., 1940.)

The 1941 Award was made to G. L. Dimmick, for his development activities in motion picture sound recording. (Citation published Dec., 1941.)

No Awards were made in 1942 and 1943.

The present Chairman of the Progress Medal Award Committee is J. I. Crabtree.

FIFTY-FIFTH SEMI-ANNUAL TECHNICAL CONFERENCE

OF THE

SOCIETY OF MOTION PICTURE ENGINEERS

HOTEL PENNSYLVANIA, NEW YORK, N. Y.

APRIL 17-19, 1944

Officers in Charge

HERBERT GRIFFIN, *President*
EMERY HUSE, *Past-President*
L. L. RYDER, *Executive Vice-President*
W. C. KUNZMANN, *Convention Vice-President*
D. E. HYNDMAN, *Engineering Vice-President*
A. C. DOWNES, *Editorial Vice-President*
A. S. DICKINSON, *Financial Vice-President*
E. A. WILLIFORD, *Secretary*
M. R. BOYER, *Treasurer*

Directory of Committee Chairmen

Atlantic Coast Section	C. R. KEITH, <i>Chairman</i>
Papers Committee	W. H. OFFENHAUSER, JR., <i>Chairman</i>
	C. R. DAILY, <i>Vice-Chairman, West Coast</i>
Publicity Committee	JULIUS HABER, <i>Chairman, assisted by</i> HAROLD DESFOR
Membership and Subscription Committee	JAMES FRANK, JR., <i>Chairman</i>
Registration and Information	W. C. KUNZMANN
Reception and Local Arrangements	D. E. HYNDMAN
Hotel and Transportation	O. F. NEU
Projection Committee	H. F. HEIDEGGER, <i>Chairman, assisted by</i> Members New York Projectionists Local No. 306

Note: In order to comply with the wartime paper conservation program only names of the committee chairmen serving our Conferences will be listed in released bulletins for the duration.

The 55th Semi-Annual Technical Conference of the Society will be held in New York as scheduled and announced previously. However, owing to wartime conditions affecting hotel accommodations and food rationing, it has been decided to dispense with all social functions usually held during our meetings.

The Papers Committee has arranged a full 3-day program devoted to topics of current interest. Sessions have been scheduled for mornings and afternoons only leaving the evenings open to permit members and guests to plan personal activities.

The Conference will be strictly technical at which the application of motion pictures to war needs will be stressed, with a number of film presentations and demonstrations accompanying papers. Definite and tentative titles scheduled up to March 20th are listed in the program below.

TENTATIVE PROGRAM

Monday, April 17

9:00 a.m.

Hotel Pennsylvania, 18th Floor: Registration.

10:00 a.m.

Salle Moderne: Morning Session.

Opening of Conference by Herbert Griffin, President.

Reports by SMPE Officers and Committee Chairmen.

Symposium on High-Speed Photography:

"The Gun Sight Aiming-Point Cameras," by Capt. E. M. Watson, Army Air Forces, Wright Field, Dayton, Ohio.

*"The Eastman High-Speed Camera," by R. K. Waggershauer, Eastman Kodak Co., Rochester, N. Y.

"Photoflash Lamps as Illuminant for High-Speed Motion Picture Photography," by H. M. Lester, New York.

*"The Ultra-High-Speed Photography," by J. H. Washburn, Lockheed Aircraft Co., Los Angeles, Calif.

Symposium on Television:

"Television from the Viewpoint of a Motion Picture Producer," by Wyllis Cooper, Program Dept., National Broadcasting Co., New York.

"Television from the Viewpoint of a Broadcaster," by W. C. Miner, Television Program Dept., Columbia Broadcasting System, New York.

"A New 35-Mm Projector with a New Light Source," by T. W. M. Schaffers, North American Philips Co., Inc., Hastings-on-Hudson, N. Y.

2:00 p.m.

Salle Moderne: Afternoon Session.

"The MGM Re-Recording Console," by W. C. Miller, Sound Dept., Metro-Goldwyn-Mayer Studios, Culver City, Calif.

"Re-Recording Equalizers," by Harry Kimball, Sound Dept., Metro-Goldwyn-Mayer Studios, Culver City, Calif.

* Subject to change.

- "The Phono-Cue Starter," by W. H. Turner and Clem Portman, Sound Dept., RKO Radio Pictures Corp., Hollywood, Calif.
- "Some Turbulation Characteristics of the New 20th Century-Fox Developing Machine," by M. S. Leshing and T. M. Ingman, 20th Century-Fox Film Co., Hollywood, Calif.
- "Some Problems of Drive-In Theaters," by L. H. Walters, National Theater Supply Co., Cleveland, Ohio.
- "A Direct Reading Audio-Frequency Meter," by W. R. Strauss, North American Philips, Co., Inc., Hastings-on-Hudson, N. Y.

Tuesday, April 18—ARMY-NAVY DAY

9:00 a.m.

Hotel, 18th Floor: Registration.

10:00 a.m.

Salle Moderne: Morning Session.

Symposium on Training Films by Training Film Branch, Bureau of Aeronautics, U. S. Navy:

- "Training Film Formula," by Orville Goldner, Lt., USNR, Head Training Film Branch, Bureau of Aeronautics, U. S. Navy, Washington, D. C.
- "The Screen's the Limit," by R. B. T. Schmuck, Lt., USNR, Photographic Division, Training Film Branch, Bureau of Aeronautics, U. S. Navy, Washington, D. C.
- "The Training Film—An Instrument for the Control of Human Behavior," by H. B. Roberts, Lt., USNR, Training Film Branch, Bureau of Aeronautics, U. S. Navy, Washington, D. C.
- "Treatment of Navy Slide Films for Psychologic Impact," by J. D. Dresser, Lt., USNR, Training Film Branch, Bureau of Aeronautics, U. S. Navy, Washington, D. C.
- "Getting the Most for the Navy Training Film Dollar," by L. R. Goldfarb, Ensign, USNR, Training Film Branch, Bureau of Aeronautics, U. S. Navy, Washington, D. C.
- "It Is to Laugh," by J. E. Bauernschmidt, Lt. (j.g.), USNR, Training Film Branch, Bureau of Aeronautics, U. S. Navy, Washington, D. C.
- "The Camera Versus the Microphone in Training Film Production," by H. R. Jensen, Lt., USNR, Training Film Branch, Bureau of Aeronautics, U. S. Navy, Washington, D. C.

2:00 p.m.

Salle Moderne: Afternoon Session.

Symposium on U. S. Naval Photographic Science Laboratory:

- "The Photographic Science Laboratory of the Bureau of Aeronautics," by an Officer to be designated later.
- "The Western Electric Recording Equipment—U. S. Naval Photographic

Science Laboratory," by R. O. Strock and E. A. Dickinson, Electrical Research Products Division, Western Electric Co., New York.

*"Maurer 16-Mm Equipment at the Photographic Science Laboratory," by Sylvan Harris and J. A. Maurer, J. A. Maurer, Inc., New York.

"The PH-346A Recording Equipment," by W. C. Miller, Sound Dept., Metro-Goldwyn-Mayer Studios, Culver City, Calif.

"An Army Air Forces Portable Recording Unit," by F. T. Dyke, Lt., Hdq., 1st Motion Picture Unit, Army Air Forces, Culver City, Calif.

Wednesday, April 19

9:00 a.m.

Hotel, 18th Floor: Registration.

10:00 a.m.

Salle Moderne: Morning Session.

Symposium on 16-Mm Standardization:

Remarks of D. E. Hyndman, Engineering Vice-President.

"Current War Standardization Activities in Motion Picture Equipment," by L. T. Goldsmith, Capt., Signal Corps Photographic Center, Long Island City, N. Y.

"The Role of the American Standards Association in Motion Picture Standardization," by J. W. McNair, American Standards Association, New York.

"Some Notes on the Performance of Radio Parts Used for War Purposes," by S. L. Chertok, American Standards Association, New York.

*Status Reports by Chairmen of ASA Z-52 Subcommittees:

Subcommittee B on 16-Mm Sound, by J. A. Maurer.

Subcommittee C on 16-Mm Laboratory Practice, by M. R. Boyer.

Subcommittee D on 16-Mm Projection, by A. G. Zimmerman.

Symposium on 16-Mm:

"ABC of Photographic Sound Recording," by E. W. Kellogg, RCA Victor Division, Radio Corporation of America, Indianapolis, Ind.

*"Distortion in 16-Mm Variable-Area Recordings," by Robert McKie, RCA Victor Div., Radio Corporation of America, Hollywood, Calif.

*"Re-Recording 35-Mm Entertainment Films for 16-Mm Armed Forces Release," by P. E. Brigandi, RKO Radio Pictures Corp., and W. M. Dalglish, RCA Victor Div., Radio Corporation of America, Hollywood, Calif.

"Dubbing Variable-Density 35-Mm Sound Track to 16-Mm," by S. P. Solow, Consolidated Film Industries, Hollywood, Calif.

"A Film for Measuring Projector Steadiness," by Bell & Howell Co., Chicago, Ill.

"The Effect of Filament Location on Projection Screen Uniformity," by Bell & Howell Co., Chicago, Ill.

"A Method for Measuring the Steadiness of Motion Picture Cameras," by Bell & Howell Co., Chicago, Ill.

2:00 p.m.

Salle Moderne: Afternoon Session.

- *"The Physical Properties and Dimensional Behavior of Motion Picture Film," by Dr. J. M. Calhoun, Eastman Kodak Co., Rochester, N. Y.
- *"Some Relationships between the Physical Properties and the Behavior of Motion Picture Film," by R. H. Talbot, Eastman Kodak Co., Rochester, N. Y.
- "Some Aspects of the Storage and Preservation of 16-Mm Teaching Films," by W. H. Offenhauser, Jr., New York.
- "Some Notes on the Distribution of 16-Mm Educational Films," by L. Larsen, Educational Film Library Association, New York.
- *"Some Notes on the Circulation of 16-Mm Educational Films," by H. Sams, New York.
- "The Teaching of Basic English by Means of Feature Films," by A. Betty Lloyd, Office of Strategic Services, Washington, D. C.

REGISTRATION

The registration headquarters will be located on the 18th floor of the hotel at the entrance of the *Salle Moderne* where all technical sessions will be held. Members and guests are expected to register and receive their Conference badges and identification cards for admittance. The fee is used to defray Conference expenses.

MOTION PICTURES

Identification cards issued at the time of registration will be honored at a number of *deluxe* motion picture theaters in New York. There are many entertainment attractions available in New York to out-of-town delegates and guests, and information concerning them may be obtained at the hotel information desk or at the SMPE registration headquarters.

CURRENT LITERATURE OF INTEREST TO THE MOTION PICTURE ENGINEER

The editors present for convenient reference a list of articles dealing with subjects cognate to motion picture engineering published in a number of selected journals. Photostatic or microfilm copies of articles in magazines that are available may be obtained from The Library of Congress, Washington, D. C., or from the New York Public Library, New York, N. Y., at prevailing rates.

American Cinematographer

25 (Jan., 1944), No. 1

The Documentary Technique in Hollywood (p. 10)	J. H. HOWE
The New Acme-Dunn Optical Printer (p. 11)	L. DUNN
Proper Editing Means Better Pictures (p. 13)	C. W. CADARETTE
The Camera Is a Weapon (p. 14)	M. S. BLANKFORT
Motion Pictures' Post-War Role (p. 15)	N. D. GOLDEN
DeVry Loans Patents to Armed Forces (p. 28)	
Voice Recorded on Hair-like Wire (p. 28)	

Educational Screen

22 (Dec., 1943), No. 10

Motion Pictures—Not for Theatres, Pt. 52 (p. 383)	A. E. KROWS
23 (Jan., 1944), No. 1	
Motion Pictures—Not for Theatres, Pt. 53 (p. 19)	A. E. KROWS

International Photographer

15 (Dec., 1943), No. 11

Motion Pictures' Post-War Role (p. 5)	N. D. GOLDEN
Post-War Television (p. 11)	T. F. JOYCE
Lighting for Technicolor (p. 13)	E. PALMER

15 (Jan., 1944), No. 12

Let's Shoot 'Em Sharp (p. 7)	H. MCALPIN
Better Sound Recording (p. 9)	Y. F. FREEMAN
Action Photography (p. 13)	M. TERRELL

16 (Feb., 1944), No. 1

Anso Color Film (p. 10)	F. WING, JR.
The New Bell and Howell Camera (p. 13)	J. MCCOSKEY

International Projectionist

18 (Dec., 1943), No. 12

Analyzing Power Unit Diagrams (p. 11)	L. CHADBOURNE
Television Today, Pt. III (p. 18)	J. FRANK, JR.

Application of Relays (p. 20)

The Care and Maintenance of Motor Generator Sets
(p. 22)

H. B. SELLWOOD

Kinematograph Weekly

322 (Dec. 16, 1943), No. 1913

A Revolutionary Front-Line Camera (p. 27)

R. H. CRICKS

323 (Jan. 13, 1944), No. 1917

New Things to Come in Film Stock and Emulsions (p. 188)

T. T. BAKER

Motion Picture Herald

154 (Jan. 22, 1944), No. 4

MacLeish Asks Film Library for Nation (p. 18)

154 (Feb. 5, 1944), No. 6

Causes of Unsteady Image—and What to Do to Cure It
(p. 88)

C. E. SHULTZ

SOCIETY ANNOUNCEMENTS**ATLANTIC COAST SECTION**

The physical characteristics of film were discussed by Dr. John M. Calhoun and Mr. Ralph H. Talbot of the Eastman Kodak Company, Rochester, at a meeting of the Atlantic Coast Section on February 23d. Dr. Calhoun's topic was "The Physical Properties and Dimensional Behavior of Motion Picture Film." A brief description was given of the manufacture of motion picture film, particularly the film base, which was illustrated with an 8-min excerpt from an Eastman 16-mm film entitled "Highlights and Shadows." Dr. Calhoun explained the physical properties of film such as strength, stretch, tearing resistance, cold flow, brittleness, *etc.*, as they bear on projection performance.

Speaking on "Some Relationships between the Physical Properties and the Behavior of Motion Picture Film," Mr. Talbot told how such properties as development shrinkage, humidity change shrinkage, and keeping shrinkage affect image placement on both negative and positive films. Some of the most important factors relating to the wear life of film are the shape of the perforation, the relation between the pitch of the sprocket and the pitch of the film, and the alignment of the film on the intermittent sprocket.

Clyde R. Keith, Chairman, opened the meeting in the Roof Garden of the Hotel Pennsylvania with a 16-mm sound film, "Army-Navy Screen Magazine," a 15-min reel for service men.

PACIFIC COAST SECTION

Methods used by Hollywood studios to transfer 35-mm entertainment films to 16-mm for distribution to the armed forces were discussed at the Pacific Coast Section meeting on February 15th. Studio and laboratory representatives told of the large-scale program now in operation for supplying 16-mm prints, and the particular problems involved. Several excerpts from recent releases were presented to demonstrate the results and limitations of 16-mm reduction prints.

The speakers comprising the symposium, held in the Review Room of Electrical Research Products, Hollywood, were Gerald Best, Warner Bros.; Philip Brigandi, RKO Radio; Samuel Cohen, Consolidated Film Industries; Wesley Miller, MGM; and Wallace Wolfe, RCA. Discussion from the audience followed presentation of the papers.

A second meeting in February was arranged by the PCS Program Committee on Tuesday, the 29th. Michael Leshing, superintendent of the Twentieth Century-Fox Film Laboratory, described turbulation in motion picture film processing and, assisted by members of his staff, demonstrated an improved developing machine recently completed by the studio. Over 100 members and guests attended the meeting in the Grandeur Projection Room on the Fox lot.

It is planned to publish these papers in future issues of the JOURNAL.

MEMBERS OF THE SOCIETY
LOST IN THE SERVICE OF
THEIR COUNTRY

FRANKLIN C. GILBERT

ISRAEL H. TILLES

Now Being Distributed

THE TECHNIQUE OF MOTION PICTURE PRODUCTION

Covering current technical practices in motion picture production, presented as a Symposium at the 51st Semi-Annual Technical Conference of the SMPE in Hollywood, 1942. . . . Now published in book form.

150 Pages—41 Illustrations

Each section written by a specialist in the motion picture industry. . . Authentic information on various technical problems of motion picture production.

CONTENTS

- | | | |
|------|---|---|
| I | Technology in the Art of Producing Motion Pictures..... | Leon S. Becker |
| II | Cinematography in the Hollywood Studios:
Black and White Cinematography..... | John W. Boyle |
| | Putting Clouds into Exterior Scenes..... | Charles G. Clarke |
| | Technicolor Cinematography..... | Winton Hoch |
| III | Special Photographic Effects..... | Fred M. Sersen |
| IV | Re-Recording Sound Motion Pictures..... | L. T. Goldsmith |
| V | The Technique of Production Sound Recording.. | Homer G. Tasker |
| VI | Prescoring and Scoring..... | Bernard B. Brown |
| VII | Illumination in Motion Picture Production..... | R. G. Linderman, C. W. Handley and A. Rodgers |
| VIII | The Paramount Transparency Process Projection Equipment..... | Farciot Edouart |
| IX | Motion Picture Laboratory Practices..... | James R. Wilkinson |
| X | The Cutting and Editing of Motion Pictures... | Frederick Y. Smith |
| XI | The Projection of Motion Pictures..... | Herbert A. Starke |

THE TECHNIQUE OF MOTION PICTURE PRODUCTION is a useful and valuable reference for technicians, students, librarians, and others desiring technological data on the motion picture industry compiled in one volume.

Price \$3.50*

Published for the Society of Motion Picture Engineers by Interscience Publishers, Inc.,
215 Fourth Avenue, New York 3, N. Y.

* 20% discount to members in good standing if ordered through SMPE.
Orders must be accompanied by check or money order. Use form on other side.

**PREFACE TO
THE TECHNIQUE OF MOTION PICTURE PRODUCTION**

At the Spring 1942 Technical Conference of the Society of Motion Picture Engineers in Hollywood, California, a symposium was presented covering the current technical practices in the motion picture industry as applied to actual motion picture production. While information with regard to many of the subjects treated is scattered through the literature, no such complete descriptions of the various techniques involved had hitherto been assembled in such a logical, convenient, and highly educational sequence. The program was received with such acclaim by the audiences in attendance that the Board of Governors of the Society authorized the publication of these papers in book form, after their publication in the JOURNAL.

The papers of the symposium are presented in the general order of the steps taken in the production and presentation of motion pictures in the studios, laboratories, and theaters. Each section has been prepared by a man well fitted by his knowledge and experience in a particular field to give authentic information on the various problems arising in the manufacture of this great entertainment and educational medium.

It is the hope of the Society that this book will prove a useful and valuable guide to the general solution of the many problems which characterize the motion picture industry, in particular as these problems may be encountered in the post-war period of re-establishment and expansion throughout the world.

—————Order Form for The Technique of Motion Picture Production—————

**Society of Motion Picture Engineers
Hotel Pennsylvania
New York 1, N. Y.**

Date.....

Gentlemen:

Please send me **THE TECHNIQUE OF MOTION PICTURE PRODUCTION**.
Enclosed is check or money order for.....

Name:.....No. Copies.....

Address:.....

Member (\$2.80 per copy).*

Non-Member (\$3.50 per copy).*

* Add 1% Sales Tax if mailed to New York City address.

JOURNAL OF THE SOCIETY OF MOTION PICTURE ENGINEERS

Vol 42

MAY, 1944

No. 5

CONTENTS

	PAGE
Monopack Processes	J. S. FRIEDMAN 271
Notes on Operating Experience Using the Direct Positive Push-Pull Method of Recording	A. C. BLANEY 279
A Visual Light-Valve Checking Device	J. P. CORCORAN 283
The New du Pont Photo Products Control Laboratory	W. P. HILLMAN 287
Improvement in Illumination Efficiency of Motion Picture Printers	C. J. KUNZ, H. E. GOLDBERG, and C. E. IVES 294
A Simplified Variable-Density Sound Negative Developer	P. ZEFF AND S. J. TWINING 315
Society Announcement	325

(The Society is not responsible for statements of authors.)

Contents of previous issues of the JOURNAL are indexed in the
Industrial Arts Index available in public libraries.

JOURNAL OF THE SOCIETY OF MOTION PICTURE ENGINEERS

HARRY SMITH, JR., EDITOR
ARTHUR C. DOWNES, *Chairman*
Board of Editors

JOHN I. CRABTREE ALFRED N. GOLDSMITH EDWARD W. KELLOGG
CLYDE R. KEITH ALAN M. GUNDELFINGER CHARLES W. HANDLEY
ARTHUR C. HARDY

Officers of the Society

- **President*: HERBERT GRIFFIN,
133 E. Santa Anita Ave., Burbank, Calif.
**Past-President*: EMERY HUSE,
6706 Santa Monica Blvd., Hollywood, Calif.
**Executive Vice-President*: LOREN L. RYDER,
5451 Marathon St., Hollywood, Calif.
***Engineering Vice-President*: DONALD E. HYNDMAN,
350 Madison Ave., New York, N. Y.
**Editorial Vice-President*: ARTHUR C. DOWNES,
Box 6087, Cleveland, Ohio.
***Financial Vice-President*: ARTHUR S. DICKINSON,
28 W. 44th St., New York, N. Y.
**Convention Vice-President*: WILLIAM C. KUNZMANN,
Box 6087, Cleveland, Ohio.
**Secretary*: E. ALLAN WILLIFORD,
30 E. 42d St., New York, N. Y.
**Treasurer*: M. R. BOYER
350 Fifth Ave., New York, N. Y.

Governors

- **FRANK E. CARLSON, Nela Park, Cleveland, Ohio.
*†CHARLES W. HANDLEY, 1960 W. 84th St., Los Angeles, Calif.
**EDWARD M. HONAN, 6601 Romaine St., Hollywood, Calif.
*†CLYDE R. KEITH, 195 Broadway, New York, N. Y.
**JOHN A. MAURER, 117 E. 24th St., New York, N. Y.
*HOLLIS W. MOYSE, 6656 Santa Monica Blvd., Hollywood, Calif.
*WILLIAM A. MUELLER, 4000 W. Olive Ave., Burbank, Calif.
*H. W. REMERSHIED, 716 N. La Brea St., Hollywood, Calif.
**EARL I. SPONABLE, 360 W. 54th St., New York, N. Y.
*JOSEPH H. SPRAY, 1277 E. 14th St., Brooklyn, N. Y.
*REEVE O. STROCK, 111 Eighth Ave., New York, N. Y.
**WALLACE V. WOLFE, 1016 N. Sycamore St., Hollywood, Calif.

*Term expires December 31, 1944.

**Term expires December 31, 1945.

†Chairman, Pacific Coast Section.

‡Chairman, Atlantic Coast Section.

Subscription to non-members, \$8.00 per annum; to members, \$5.00 per annum, included in their annual membership dues; single copies, \$1.00. A discount on subscription or single copies of 15 per cent is allowed to accredited agencies. Order from the Society of Motion Picture Engineers, Inc., Hotel Pennsylvania, New York 1, N. Y.

Published monthly at Easton, Pa., by the Society of Motion Picture Engineers, Inc.

Publication Office, 20th & Northampton Sts., Easton, Pa.

General and Editorial Office, Hotel Pennsylvania, New York 1, N. Y.

Entered as second-class matter January 15, 1930, at the Post Office at Easton, Pa., under the Act of March 3, 1879. Copyrighted, 1944, by the Society of Motion Picture Engineers, Inc.

JOURNAL OF THE SOCIETY OF MOTION PICTURE ENGINEERS

Vol 42

MAY, 1944

No. 5

MONOPACK PROCESSES*

J. S. FRIEDMAN**

Summary.—The modern trend toward the use of monopack film presents the photographic technician with the problem of making color separations from the resultant color transparency. These should approach in quality those obtained directly by the use of one-shot cameras. A procedure is outlined to accomplish this, using negative masks to correct for the overlaps in the spectral curves of the dye images in the transparency.

The trend in color processes at the present time is toward the use of monopack film. This is a multilayered affair in which 3 emulsions are coated one on top of the other, and segregated from each other by filter layers. By a combination of filters and special sensitization of the individual emulsions, it becomes possible to achieve any desired type of color analysis, together with a physical separation of the 3 component units. These exist as monochrome dye images lying in layers one above the other, in exact registry. Ansco Color reversible film, Ansco Color negative film, Kodachrome, and Kodacolor are packs of this type.

Experience gained over a long period of time has taught us that for best color reproduction, color analysis should be made through a set of filters such as the *A*, *B*, and *C-5* Wratten filters. This is the procedure used by Technicolor in their successful reproduction process, and it is the standard to which monopack film strives. An examination of spectrograms of the individual layer sensitivities indicates that up to exposure levels which encompass brightness ranges from 1 to 10, the quality of the separations achieved during the formation of the latent image corresponds very closely to the Technicolor standard. It is only when this range is exceeded that the green sensitive layer overlaps the others, but even here the degree of overlap is not too large.

* Presented Oct. 22, 1943, at the Technical Conference in Hollywood.

** American Photography, Binghamton, N. Y.

We can therefore assume that the quality of the separations achieved during the formation of the latent image corresponds quite closely to the standard *A*, *B*, and *C-5* separations of the beam-splitting camera. Monopack film becomes, therefore, an ideal material for use in motion pictures, since it does away with the delicate and intricate one-shot camera, and relegates the precision work involved in the making of separations to the precision laboratory where it belongs. That the industry is well aware of this is indicated in the interest shown by Technicolor and the Army and Navy in monopack film.

An exposed monopack film must be processed in such a manner that each of the latent images in the 3 layers becomes converted into a readily differentiable form. The best way to do this, short of physically separating the 3 layers into 3 separate films, is to convert the image in the blue sensitive layer into a form that will modulate blue light and not any other—that is, into a yellow colored image. Similarly, the image in the green sensitive layer must be converted into a magenta, and that in the red sensitive layer into a cyan. The procedure by which this is accomplished is the same in principle in Ansco Color reversible, Ansco Color negative, Kodachrome, and Kodacolor. They differ from each other only in details.

The underlying principle is the Fischer and Siegrist extension of the idea of "color development" previously proposed by Homolka. The extension is based upon the fact that the oxidation products of certain phenylene diamine and amino phenol developers, react with aromatic amino and hydroxy bodies, or with compounds which contain an active methine group, to form highly colored bodies. In general, cyan colors are obtained by the use of hydroxy bodies, yellows by the use of aceto-acetic ester derivatives, and magentas by the use of heterocyclic rings such as pyrazolone or substituted acetonitriles. This classification is only a very general one, for it is possible to obtain yellow oranges from some pyrazolones.

In Kodachrome processing, the exposed monopack is developed to form a silver image. The red sensitive layer is then completely fogged by means of red light, then developed with a phenylene diamine developer which contains a coupler such as ortho-phenylphenol. The net result is that together with the positive silver image there is formed an equivalent quantity of a cyan pigment. Since only the red sensitive grains have been reversed, the resultant dye image will be a record of the red densities as they were reflected from

every point in the original scene. By analogous means, it is possible to reverse the green and blue layers individually, and in that way deposit a magenta dye image in the green sensitive layer, and a yellow dye image in the blue. After the 3 layers have been individually reversed, the metallic silver is removed by well-known means, leaving an image composed of 3 superimposed dyes.

The processing of the 2 Ansco Color materials and of Kodacolor differs from this materially. In these, the emulsion layers contain the couplers. Thus in the red sensitive layer there is present a body such as ortho-phenyl-phenol. This must be present in such a form that it will not wander from one layer to the next during the coating operations or during processing. The body must be immobilized. The Ansco Color materials differ from Kodacolor in the manner whereby this immobilization is achieved.

In Ansco Color the coupler is made nondiffusing by attaching to it a very heavy group such as a resin acid residue, or a higher fatty acid residue. This is achieved without making the body insoluble, so that in an Ansco Color emulsion the coupler remains molecularly dispersed throughout each layer. This tends to give the dye image the grain structure of the reversed silver image, so that an Ansco Color image should not be any more grainy than the image of a reversed positive film. This is true not only for Ansco Color reversible film, but also for Ansco Color negative film.

The first is developed by reversal. The exposed film is developed in a black-and-white developer compounded to allow a later reversal. It is then exposed to white light and color developed with a solution containing a para-phenylene-diamine developing agent. The same developer is used to convert all 3 layers into their respective colors, since the couplers are already present in each layer. Hence only a single operation suffices. The removal of the metallic silver, followed by fixation, completes the process.

Ansco Color negative development is even simpler. The film is merely developed in a phenylene-diamine solution, the resultant silver is removed by a silver bleach, and the film is finally fixed.

In Kodacolor the immobilization of the coupler is done in a different manner. The coupler is first dissolved in a water insoluble but water permeable resin, and it is then dispersed in a gelatin solution. The gelatin is finally mixed with the emulsion. The insolubility of the resin prevents its diffusion from one layer to the next. The water permeability allows free access of the oxidized developer to the

coupling agent so that dye formation is not hindered. The thought arises that the dispersion of a water insoluble resin in gelatin would cause a loss of light and definition by light scatter. This would be true only if the index of refraction of the resin particles were materially different from that of gelatin. Evidently this is not so.

In the Kodachrome developing solution, the couplers are in molecular dispersion. In Ansco film the couplers are molecularly dispersed in the gelatin layers, therefore are in true solution. Thus in both cases dye formation takes place immediately adjacent to the developed silver grain. The grain structure in the final dye image is closely allied to that of the reversed silver image.

In Kodacolor the couplers are dispersed in the layers as discrete particles. The oxidized developer must diffuse from the locality of its formation until it reaches the resin particle. The grain distribution of the final image is related, therefore, to the distribution of the relatively coarse resin particles, rather than to the reversed silver image.

It would be expected that Kodacolor would be less suitable for extreme enlargements than Kodachrome or the Ansco Color materials. Kodacolor is processed exactly like Ansco Color negative. It is extremely simple, and there is no reason why such processing could not be carried out by the individual operator.

The exciting thing about monopack film is that it makes every black-and-white camera a color camera. It was pointed out above that the original exposure gave a color analysis that approached the standard obtained by a beam splitter. This approach is destroyed after the film is converted into a colored transparency, be that a positive or a negative. It is possible, however, to correct for the flaws introduced by the color processing. How this can be done is discussed by Prof. C. W. Miller in his book, *Principles of Photographic Reproduction*. He uses a rather elegant mathematical method which gives promise of great utility in the science of color reproduction in general. The present writer discussed the problem from a straightforward photographic angle in his *Color Photography* columns in *American Photography*.

Following Prof. Miller, we will designate a color in terms of its ability to absorb the red, green, and blue primary. We can therefore write 3 equations to represent the cyan, magenta, and yellow colors used in the reproduction process, thus:

$$c = a_{11}r + a_{12}g + a_{13}b \quad (1)$$

$$m = a_{21}r + a_{22}g + a_{23}b \quad (2)$$

$$y = a_{31}r + a_{32}g + a_{33}b \quad (3)$$

Here c , m , y , r , g , and b represent cyan, magenta, yellow, red, green, and blue, respectively. The first equation states that the cyan dye absorbs the red light sufficiently to yield a density of a_{11} , the green light sufficiently to give a density of a_{12} , and the blue light sufficiently to yield a density of a_{13} . The set of 3 equations gives rise to a matrix which we call the color matrix,

$$(a) = \begin{pmatrix} a_{11} & a_{12} & a_{13} \\ a_{21} & a_{22} & a_{23} \\ a_{31} & a_{32} & a_{33} \end{pmatrix} \quad (4)$$

The ideal cyan dye is one which will absorb the red light to the extent to which the dye is present at any point, but which will not absorb any green or blue light. In terms of the elements of the matrix above, this means that the numerical value for the constant a_{11} should be something greater than zero, but for the constants a_{12} and a_{13} the value should be zero. The more removed the values are from zero, the poorer the cyan dye from the point of view of color reproduction processes. Similar situations hold for the magenta and yellow dyes, but now it is the constants a_{22} and a_{33} which must have values greater than zero and constants a_{21} , a_{23} , a_{31} , and a_{32} which must have values of zero. Thus an ideal set of dyes would give rise to a matrix which would have values of zero for all of its nondiagonal terms, and constants for the diagonal terms. Needless to say such dyes are unknown. That is why color distortion and degradation takes place whenever color reproduction is attempted.

Consider a color transparency which contains beside the image of interest, also an image of a standard color. This can very well be a gray of density 1.00, a color which reflects or transmits only 10 per cent of the red, green, and blue primaries. The color can be represented by the equation

$$1.00r + 1.00g + 1.00b \quad (5)$$

where r , g , and b represent red, green and blue. In all color processes, the attempt is made to image a gray scale correctly. This means that a gray of density 1.00 will be reproduced as a gray of density 1.00. Suppose it requires a cyan dye concentration of x , a magenta dye concentration of y , and a yellow dye concentration of z to yield a gray of density 1.00 through each of the 3 separation filters. Then we must have

$$xa_{11} + ya_{21} + za_{31} = 1.00 \quad (6)$$

$$xa_{12} + ya_{22} + za_{32} = 1.00 \quad (7)$$

$$xa_{13} + ya_{23} + za_{33} = 1.00 \quad (8)$$

The elementary principles of algebra tell us that x , y , and z can have but one value which will satisfy the 3 equations. Therefore the problem of choosing emulsions which will correctly image a gray scale is a solvable one. We choose our emulsions so that upon equal exposure and identical processing, the cyan, magenta, and yellow dyes will be present in the ratios $x:y:z$.

The problem which we have set for ourselves is to determine the conditions under which separations from a color transparency will approximate those of a one-shot camera. We have pointed out above that each dye image is a close approach to the image of one primary color as it is present in the original. Thus if we can copy each of these without any interferences from the others, our object is achieved. To do this we must know the densities each of the 3 dye images present to the separation filters, when they are present in an amount necessary to yield a gray of density 1.00. This is not an impossible photographic problem, so we can assume it to be known. Let us suppose that the following equations represent the data:

$$c = x_{11}r + x_{12}g + x_{13}b \quad (9)$$

$$m = x_{21}r + x_{22}g + x_{23}b \quad (10)$$

$$y = x_{31}r + x_{32}g + x_{33}b \quad (11)$$

When we pass the light transmitted by the red filter through the cyan layer, the beam will be modulated. The original beam had a cross section every point of which had the same intensity. After passage through the cyan layer of the transparency the cross section was no longer uniform in intensity, but the intensities varied from point to point in accordance to the pattern imposed by the cyan dye image. This we define as *modulation*.

When the light passes through the magenta layer, it will again be modulated, although to a much smaller extent, since the value for the constant x_{21} is, as a rule, much smaller than the value for x_{11} . Hence upon the other pattern, there will be superimposed the pattern of the magenta layer. To the extent to which modulation takes place during the passage of the red light through the magenta and yellow layers, color distortion takes place.

If we concentrate our attention again upon our standard color patch, the gray with a density of 1.00, we know that we want our copy to image a red density of 1.00. This means that we want our

red separation to copy the cyan layer at this point of the transparency in such a manner that upon printing it will yield a density of 1.00.

The cyan image at this point has a density of x_{11} . Upon passage through all 3 layers, the density actually copied will be $x_{11} + x_{21} + x_{31} = 1.00$. Therefore we must do something which will convert the sum $x_{11} + x_{21} + x_{31}$ into x_{11} . The procedure which accomplishes this is termed *masking*, *photographic addition* and *subtraction*. Addition is achieved by registering a positive image with a positive, and subtraction is achieved by registering a negative with a positive.

In our case subtraction is called for. We must subtract from the color transparency the values $x_{21} + x_{31}$, where x_{21} represents a negative of the magenta layer, and x_{31} a negative of the yellow layer. A simple way to do this is to make 2 exposures upon the same emulsion, one with green light to copy the magenta layer, the other with blue light to copy the yellow. The exposures are of such duration that the ratio of the green latent image to that of the blue will be $x_{21}:x_{31}$. The mask is then developed to a gamma which is equal to $x_{21} + x_{31}$. This constitutes the mask for the red filter separation. The masked transparency will have completely neutralized the densities x_{21} and x_{31} in the magenta and cyan layers, so that they will no longer modulate the red light imagewise. Only the densities in the cyan layer will give such modulation, and at the point where our present interest lies, this modulation will be a measure of the term value x_{11} . In a similar manner we can make masks which will serve for the other 2 separations.

In the case of the red and blue separations, this double exposure is not necessary. The curves for the magenta and the cyan dyes intersect in the regions of their high absorptions. Let us suppose that they intersect at the point corresponding to a wave length of 590 $m\mu$. This means that light of this wave length is absorbed by the 2 layers in equal quantities. To the right of this, more light is absorbed by the cyan image, and to the left more light is absorbed by the magenta. Thus by a proper choice of monochromatic light we can vary the ratio of the cyan to magenta images in any desired proportions. We desire a ratio of cyan to magenta that is equal to $x_{13}:x_{23}$. The yellow and magenta curves intersect somewhere in the neighborhood of 475 $m\mu$, so here again we can pick a wave length whose absorption by these 2 will be in the ratio of $x_{31}:x_{21}$.

We have made masks whose use enables us to copy the densities present in only one of the layers in the color transparency, without

interference from the other two. This enables us to make color-correct separations. The next problem is how to make them properly balanced. We turn again to our standard color patch. After masking we copy a red density equal to x_{11} , a green density equal to x_{22} , and a blue density equal to x_{33} . We know that these values represent something which originally was a neutral that transmitted only 10 per cent of the light incident upon it. Therefore x_{11} is the density in the cyan layer which is the image of a density whose value was 1.00. For proper balance, then, the value x_{11} must be copied so that a print made through the negative will yield a density of 1.00. This will be achieved if the red filter separation will be developed to a gamma equal to $1.00/x_{11}$ that of the desired negative gamma. Similarly the green separation must be developed to a gamma that is $1.00/x_{22}$ that of the desired value, and the blue separation must be developed to a gamma which is equal to $1.00/x_{33}$ that of the desired value.

It should be pointed out that the reproduction process which is to be used does not enter into this discussion at all. If any corrections are to be made to compensate for defection in that procedure, they must be made over and above the ones noted here. We have merely offered a solution to the process for the making of accurate separations from a color transparency which uses a set of subtractive primaries characterized by the color matrix

$$(x) = \begin{pmatrix} x_{11} & x_{12} & x_{13} \\ x_{21} & x_{22} & x_{23} \\ x_{31} & x_{32} & x_{33} \end{pmatrix} \quad (12)$$

The above procedure, outlined in greater detail in the August and October, 1943, issues of *American Photography*, represents a theoretical solution. In actual practice we can make some short cuts. An examination of the actual curves for the subtractive primaries used in Ansco Color or Kodachrome indicates that if the red separation be made with light whose wave length is greater than $650 \text{ m}\mu$, it will not be necessary to mask to obtain a separation reasonably free from color distortion. A tolerable green separation can be made using light of wave length about $525 \text{ m}\mu$. It is only the blue separation which must be color corrected, and this can be done by means of a single exposure, as indicated above. However, much may be said for the use of 3 masks, as this will reduce the otherwise unreasonable and unreproducible light intensity range of the normal color transparency, which incidentally arises mainly from the deficiencies of the subtractive primaries used.

NOTES ON OPERATING EXPERIENCE USING THE DIRECT POSITIVE PUSH-PULL METHOD OF RECORDING*

A. C. BLANEY**

Summary.—Experience with the direct positive method of recording on film has proved to be practical under normal operating conditions. The advantages with respect to sound quality, operation, and cost are pointed out.

The direct positive method of sound recording was discussed at the 1939 Spring Meeting of the Society in Hollywood.¹ That paper discussed the general technical problems involved in the recording of direct positive tracks and also described the details of a particular system having new and outstanding features. Since that time experience has been gained in the use and operation of the direct positive method of recording. It is the purpose of this paper to comment on these experiences and to point out the practical advantages which have been realized.

The variable-area method of recording has the fundamental advantage that the original negative can be reproduced directly without appreciable wave shape distortion. The motion picture industry has always made a somewhat limited use of this advantage usually for the purpose of saving time or the expense of making prints. Reproduction from the negative is, of course, not recommended for best results, but the relative degree of quality which can be realized is evident from the fact that one of our licensees makes a standard practice of using negative tracks for previews for all short subjects.

Spreading of the photographic image in standard variable-area sound-tracks gives rise to a rectification component at high frequencies which, if not eliminated, results in sibilant distortion and a general loss in quality. High-frequency rectification may be brought under complete control in the printing process, because of the fact that the resultant distortion from the negative and the print is of opposite signs and will completely cancel under certain conditions of negative and print density. High-frequency rectification also may be elimi-

* Presented Oct. 20, 1943, at the Technical Conference in Hollywood.

** RCA Victor Division of Radio Corporation of America, Hollywood.

nated in the original recording by choosing the proper density, but for the films which are now available, this cancellation density is in the order of 0.6 to 0.8 which is obviously too low to be practical. The push-pull method is ideal for direct positive recording because the rectification component is eliminated in reproduction. This increases the processing tolerances and, with the absence of the printer variable, considerably reduces the risks involved in obtaining high-quality original recordings.

The direct positive method of recording has less noise than the normal negative-print process, because the film is exposed directly and thus does not contain an image of dirt particles or scratches that are always present, to some degree, on the negative. Noise is further reduced by using the Class *B* push-pull type of track and fine-grain emulsions. It must also be recalled that the Class *B* type of track, in addition to being more practical with narrower "zero" lines than other types, has the added advantage of instantaneous timing with respect to noise reduction. It also has a higher signal-to-noise ratio at 100 per cent modulation than the other types, because of the higher ratio of opaque-to-clear area. All of these factors add up to provide a recording method which has a signal-to-noise ratio and general overall quality of such a value that it can be used in the same manner as the original material.

Freedom from noise is definitely the most important feature of this method of recording. We have not attempted to determine an absolute figure representing the actual noise level. It is well known that erratic "clicks" or "pops" are more objectionable than a continuous noise of a higher average level. It is believed sufficient to state that with this method of recording, film noise is no longer a problem, and the signal can be altered in level when re-recording as may be desired. Those familiar with practical recording operations, particularly "mixers," will appreciate how these improvements in the original sound record simplify their problem. It is no longer necessary to spend precious time on rehearsals in order to squeeze the sound into the track limits. Recordings of a large orchestra or other types of material are made at a safe level with very little, if any, attempt by the mixer to adjust the level during the take. This original record can then be used for re-recording with all of the freedom of the original sound source, and with the added advantage that it will always reproduce exactly the same. The factor of human error or variation always presents a problem to the mixer, but with the direct positive

track as a source of sound, he is free to concentrate on the dramatic effect to be produced.

This high-quality track also provides a better medium for the recording of certain types of sound effects, such as taps and other sounds having a steep wave front, which are normally difficult to record. Here again, these difficult sounds can be recorded at a safe level and then re-recorded in a manner to produce the desired dramatic effect. The direct positive method of recording permits a saving of film which is of special importance at this time. For example, special sound effects, which are applicable for only one picture, can be cut into the master tracks for re-recording without making new prints for this purpose.

Prints for cutting and editing purposes are made in the usual manner. These prints will, of course, have the appearance of negatives in that the ratio of clear-to-opaque area is relatively high. They are, however, entirely satisfactory for the purpose. When the editing is complete, the direct positive original track is then cut the same as a negative is cut, and instead of being printed it is used directly in the reproducer of the re-recording channel thus saving an appreciable amount of print stock.

During the past 2 years this method of recording has been used considerably and has been found to have a distinct advantage for certain types of material. This experience has proved that the method is practical under normal operating conditions and provides a number of technical advantages as well as a definite saving in expense and film. It can be definitely stated that the final results after re-recording are better than the original recording. This is a broad statement and it is not intended to convey the idea that harmonic distortion or similar defects are eliminated by some magic process.

There are a number of distinct features in this method of recording which improve the final result. First, the original recordings are made with a minimum number of rehearsals and "takes" which greatly reduces the strain on the artist. Too frequently the artists are tired and not able to give their best performances by the time the final take is made. The other improvements result from the re-recording mixer being able to do a superior job because (1) he is confident that the original sound will be accurately repeated, (2) he is not troubled by film noise when raising levels or accentuating high frequency, and (3) he does not have to work under the pressure of keeping the recording time to a minimum. Further use of this method

will undoubtedly reveal more applications which will extend its use in the industry.

REFERENCE

¹ DIMMICK, G. L., AND BLANEY, A. C.: "A Direct Positive System of Sound Recording," *J. Soc. Mot. Pict. Eng.*, **XXXIII** (Nov., 1939), p. 479.

A VISUAL LIGHT-VALVE CHECKING DEVICE*

J. P. CORCORAN**

Summary.—This paper describes a method whereby the light-valve image may be magnified and projected on a screen to permit the inspection of the valve's operation under both a static condition and the application of steady tone.

Since the inception of sound recording on film using a light valve as a modulator, the usual practice of stringing, tuning, and spacing the dural ribbons in the valve has been accomplished by the use of a jig and microscope. This method is still indispensable for these preliminary operations.

The second step usually performed by the light-valve technician is to ascertain the power required for 100 per cent modulation of the ribbons at some predetermined frequency, usually between 400 and 1000 cycles. In most cases, this is determined by listening to the distortion which occurs when 100 per cent modulation of the ribbons is exceeded. The accuracy of the results thus obtained is influenced by the harmonic content of the oscillator and associated amplifiers, plus the human error.

With the introduction of the Western Electric RA1060 type of 4-ribbon valve, it appeared that greater accuracy could be achieved if a magnified image of the valve aperture was projected on a screen providing a visual method of determining full modulation. It was to accomplish this that the testing device which I shall describe was built up as a unit.

Fig. 1 shows the general arrangement of the cabinet. It is 2 ft wide by 3 ft long and 4 ft high. The lower enclosed portion contains the 12-v power supply, connection for 110 v a-c, together with the necessary transformers, resistors, and wiring. A standard recording lamp and light-valve magnet coil are also located here. The upper portion contains the lenses, mirrors, motor generator, slotted disk, and the viewing screen.

* Presented Oct. 22, 1943, at the Technical Conference in Hollywood.

** Twentieth Century-Fox Film Corporation, Beverly Hills, Calif.

Referring to Fig. 2, the lens system consists of a condenser lens, 1 in. in diameter, which focuses the lamp filament on the ribbons. A photographic lens having a focus of $1\frac{5}{8}$ in. is used to magnify the aperture and focus it in space adjacent to the plane surface of the cylindrical lens after deflecting the light 90 degrees by a mirror. The magnification realized at this point is approximately 6 times. This image is in turn magnified by the cylindrical lens which has a focus of



FIG. 1. Light-valve testing cabinet.

approximately $\frac{1}{2}$ in. This lens is $4\frac{1}{2}$ in. long and was obtained by splitting a $\frac{1}{2}$ -in. rod of optical lucite. The light, after passing through the cylinder lens, is reflected by a mirror back to a viewing screen where the edges of the ribbons are brought to focus.

This mirror can be rotated between stops by a rod extending out the left side of the cabinet. Its rotation switches the light from the lower portion of the screen to the upper part, where it is interrupted by a slotted disk attached to the motor shaft. When the valve is energized by a signal from the alternator section of the motor, stroboscopic patterns are produced. These patterns resemble, in shape,

the envelope which results from amplitude modulation of a carrier by steady tone.

The motor is a series a-c motor and its speed is controlled by a rheostat which is located on the lower right side of the cabinet. The motor has a speed range, as used, from 400 rpm to around 5000 rpm. The audio frequency generated from the alternator end of the motor is 51 cycles per revolution of the shaft. Thus, at a speed of 1175 rpm, the frequency is near 1000 cycles. The power output at this point is approximately 0.15 w. The image size of a one-mil by 400-

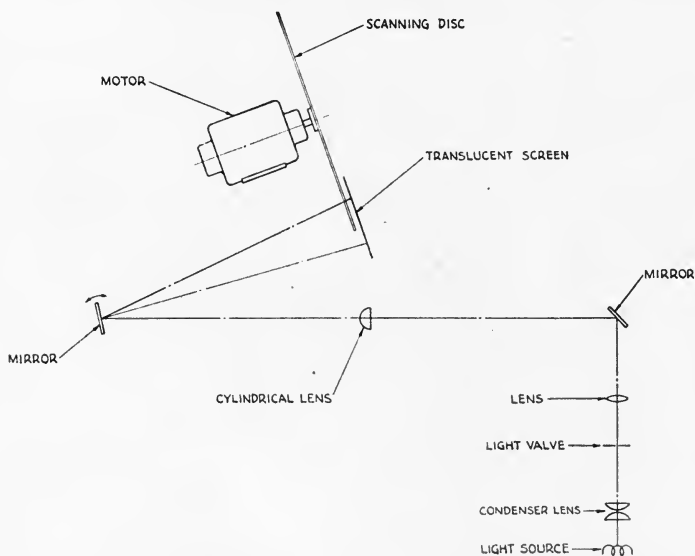

FIG. 2. Optical schematic, light-valve checking device.

mil light-valve aperture as projected on the screen is approximately $\frac{3}{16}$ in. wide by $\frac{5^5}{16}$ in. long. This gives a vertical magnification of approximately 187 times with a horizontal magnification of 13.3 times. The stroboscopic pattern, as viewed on the screen, indicates modulation at 9 points equally spaced along the length of the ribbons. As 100 per cent modulation is approached, the pattern begins to separate. This point can be determined to within 0.2 of a db.

Bias current can be applied to the ribbons while modulating them with the signal from the generator. The valve spacing can be reduced equivalent to 12 db noise reduction, with the image still giving an indication of full modulation.

For the inspection of closure or bias spacing, the image is projected to the lower portion of the screen by tilting the mirror. The frequency at which the ribbons resonate can be determined, from the projected image, by the apparent change in spacing which occurs sharply at the tuning point as they are modulated by a signal from an external oscillator.

A brief summary of the use made of this projected image method for checking valves may be stated as follows:

- (1) Determination of 100 per cent modulation of each pair of ribbons to within 0.2 of a db over several points along the ribbons.
- (2) Observation of closure or consistency of spacing of the ribbons when bias current is applied.
- (3) Checking for dirt or foreign particles in the valve.
- (4) Observation of alignment of the optical flats.
- (5) Determining the amount of bias current for noise-reduction values up to 12 db.
- (6) Checking ribbons for shorts or grounds under dynamic conditions.
- (7) Checking tuning frequency of each ribbon.

THE NEW DU PONT PHOTO PRODUCTS CONTROL LABORATORY*

W. P. HILLMAN**

Summary.—*Constructional, operational, and personnel features of the new du Pont Photo Products control laboratory are outlined.*

I. INTRODUCTION

Quality of production, as an essential of continuing success, is of interest to both the consumer and the manufacturer of raw film. A primary factor in furthering the aims of both parties is a control laboratory with not only modern equipment, but also an organization indoctrinated with a passion for facts and a high degree of intellectual honesty. The new du Pont control laboratory embodies features learned through years of experience in the service of technical industry. This discussion will be limited to cine products rather than the materials of the X-ray, portrait, or graphic arts fields. An outline is presented of the equipment arrangement and personnel for the efficient testing necessary to assure production of uniform, reliable photographic products to meet the requirements of the motion picture industry.

II. DESIGN AND CONSTRUCTION

As a first step in the design of the new laboratory, its objectives were studied from the standpoints of straight-line flow of samples, systems of routing through the laboratory, assembly of results, approval of material, and distribution of information. A system of operation was evolved, as a result of these studies, with a central office to control all activities and to correlate all results. A status clerk follows the flow of tests from a sample receiving room on the ground floor level through the processing equipment and areas to the office. The data are correlated by product supervisors who are responsible for the assembly of results and the distribution of information.

* Presented Oct. 18, 1943, at the Technical Conference in Hollywood.

** Photo Products Department, E. I. du Pont de Nemours and Co., Parlin, N. J.

Our experience and the literature show that the most uniform photographic testing can be achieved only under closely controlled conditions of temperature and humidity. Accordingly, an air-conditioned building of modern fireproof construction was designed and built.

The outside walls around the structural steel frame are of brick on 3 sides, while the fourth or rear wall is of hollow tile in anticipation of future enlargement. Service lines running in this direction are over-size to take care of future requirements. The insulation of the outside walls consists of an air space and a 2-in. layer of rock cork. The inside surfaces of the walls in most of the building are of white tile to a height of 5 ft, with cement plaster on the rest of the walls and on the ceilings.

The floors are of 3 types. Those that are frequently wet are of a bituminous composition not only to withstand moisture but also to prevent slipping. The floors in the hallways and washrooms are of terrazzo or composition stone. The floors of areas which are sound treated are of mastic tile. These details of floors, walls, and ceilings all promote cleanliness.

The reading and calculating room, inspection room, and office have sound-absorbing Celotex ceilings to reduce the general noise level. The projection room, equipped with twin sound projectors, has the customary sound-treated broken wall and ceiling surfaces as recommended by the sound engineers.

False ceilings above each of the 3 floors, in conjunction with a central service shaft, carry all service lines, ducts, heaters, and thermostat valves. This permits easy access to all the services in case of trouble, avoids going into white light for many types of maintenance work, and makes it much easier to keep the operating rooms at the high degree of cleanliness that is necessary for dependable testing of photographic film.

III. BUILDING, EQUIPMENT AND SERVICES

The building service room is located on the top floor to conserve space on the lower, more easily conditioned floors. This room contains conditioners for the building and the dryers, the motor generator sets for the projectors and other special d-c uses, battery sets for uniform sources of d-c for special equipment, the air compressor, hot water heater, and all panels, switches, and starters for all motors of over 1 hp.

The building conditioning system, which maintains constant conditions throughout the operating rooms of the laboratory, starts with a mixture of recirculating air from the building and varying amounts of make-up air from outdoors. The dew point of this mixture is maintained constantly at 59 F by heating the spray circulating water in cold weather with steam and by cooling in hot weather by means of a 60-ton Freon system.

An automatic damper on the outdoor air intake is arranged to take in the maximum amount of outdoor air when its temperature is around 59 F. When the weather gets colder or warmer than this, the damper cuts down the outside air to save steam or refrigeration as the case may be. The minimum limit of outside air intake is set by the ventilation requirements. All the air after leaving the spray chamber passes through drop-eliminator plates, and a preheater, and thence through an "Electromatic" filter.¹ This operates on the electrical precipitation principle, the ionized dust particles being attracted to oil-covered plates and washed off in oil, collecting in the bottom of a well as sludge. The air after leaving the filter is delivered by ducts to the various parts of the building where local thermostatically controlled heaters bring it to the desired temperature.

In order to keep the air at the highest degree of cleanliness, all air supply ducts are of stainless steel. The building is kept under a slight positive pressure at all times to prevent the entrance of unfiltered air when doors are opened, and to provide a constant ventilation through the rest rooms and washrooms which are located along the outside walls of the building and have louvers in their walls.

The conditioner system for the dryers serves a different purpose. Here a constant low humidity with a constant temperature of 90 F is needed.² This requirement is met by a "Kathabar" conditioner³ and a closed recirculation system. A concentrated lithium chloride solution is circulated through the sprays in the main spray chamber at 90 F, where it takes up water from the recirculating air. The lithium chloride solution is then reconcentrated by heating and blowing outdoor air through its hot spray, after which it is cooled to 90 F and is ready to use again in the main spray chamber. The conditioned air is filtered through an "Electromatic" filter, as in the case of the general air conditioner, to avoid any trace of dust on sensitometric strips or drying films.

The strips and films go from adjacent light to dark areas through pass boxes or small light locks. Where distances are greater, strips,

written directions, and reports are handled by a pneumatic tube system connecting the sample receiving room with the status clerk in the office and with the various operating areas.

A Teletalk system connects all parts of the laboratory and is invaluable in the routing of samples and exchange of information between white light and safelight operating areas. Various types of instruments are used to fit the needs of each station. For example, the product supervisor's instruments can reach a large number of stations and require the manipulation of buttons for sending and receiving messages, while the instrument in the solution mixing room is such that the operator can receive and answer messages from the developing machine room without leaving his work.

The solution mixing and storage rooms are located on the top floor to give gravity flow for both developer and fixer solutions. The processing solutions are mixed in glass-lined and stoneware apparatus equipped with stainless steel agitators, and are stored in lead-lined tanks. They are distributed through stainless steel lines and stainless steel and rubber-lined valves to the processing equipment located on the lower floors. The fixer, after use, flows by gravity to a sump from which it is pumped by a stainless steel pump into the regeneration system on the top floor. A partial precipitation system is used in which regenerated fixer is filtered through a stainless steel leaf filter for removal of the silver sulfide.

IV. PERSONNEL

Even more important than the bricks and mortar, metals and machines of the building and equipment, are the men and women upon whom the entire operation depends. The rank and file of our operators are high school graduates. The supervisory force consists of college men with chemistry, physics, or engineering training. The standardization and maintenance of specialized test equipment are under the supervision of the physics group of the research laboratory, which is available also for general consultation.

Written specifications and standard procedures for test methods are common practice, but they do not cover the human equation and the necessity for continual emphasis on honesty of thought. Several further steps were found useful for efficient and satisfactory operation. While, in the past, procedures had been taught in small steps, these steps are now broken down into still smaller units which are taught by methods recommended in the Job Instructor Training Pro-

gram of the War Manpower Commission.⁴ The Job Instructor Training course has been given to our supervisors, shift supervisors, and key men and women, and the results have been very gratifying.

Another step which has been found useful in gaining employee cooperation and interest in honest results is our system of studying "Irregular Occurrences." Occurrences of this type are reported in writing, with all details possible, to a supervisor assigned to this work. He collects all information on the case, goes over the job instruction, and talks to the operators involved. Honest discussion and emphasis on the common objective clarifies the irregularity. Frequently the study results in a simplification of the job and occasionally a more efficient method of operation is suggested.

A third help in employee relations is our system of continuous rating. Each employee is given a written rating periodically which, of course, is discussed with the employee. The employee-supervisor relation is such that each worker knows at all times how he is getting along. These developments in personnel relation and training have contributed very largely to the fullest utilization of the abilities of the group in the approach to a common goal.

V. OPERATION

A complete control testing schedule includes exhaustive chemical, mechanical, sensitometric and practical tests on raw materials, semi-finished products, and finished products. The testing of one raw material alone, for example, gelatin, is a large subject in itself. The testing of chemically pure 99⁹⁹/₁₀₀ per cent silver nitrate is complicated by the fact that one part per million of certain impurities makes it useless for the preparation of some of our photographic emulsions. For these reasons, this presentation can cover only a relatively small portion of the details of operation.

All samples for control testing on arrival at the receiving room are grouped into sets with other materials of the same type and control samples of older emulsions. An instruction card is prepared for each set indicating the exposure and processing procedures to be used. These procedures were worked out to give the best measure of the qualities which are essential to the trade. The set of materials, routed by means of the instruction card and Teletalk follow-up, goes through the pass box into the appropriate exposing room where the operator gives the materials the required exposure, in most cases one of the following 3 types:

(1) A *1A* intensity scale⁵ exposure by means of a sensitometer⁶ consisting of a standard controlled light source and a neutral density step wedge.

(2) A *2B* time scale exposure by means of the well-known *2B* sensitometer.⁷

(3) A continuous uniform exposure by means of a specially constructed machine for giving a continuous smooth motion to the film under a constant light source.

After exposure the set of materials goes to either of 2 developing rooms as called for by the instruction card. In the strip developing room, the processing is done on machines that were designed to use relatively small amounts of developer. Uniformity of development is secured by high agitation produced by the movement of multiple blade paddles back and forth close to the surface of the film. The principle is similar to that used in other machines⁸ previously described before the Society. The developing tanks range in volume from 2 qt of developer with a 4-strip capacity on up. The small machines are very useful for testing developers. In the roll developing room there is a continuous machine with variable speed and auxiliary circulation for developer agitation. It was designed and built to permit the duplication of typical conditions encountered in trade practice, rather than for handling large quantities of any one film type. Testing schedules require the processing of many short samples of a variety of film types. The drive consists of a master motor which feeds the film into the developing tank at the desired speed and a series of following motors individually controlled in speed by the tension on the film.

The preparation and chemical control of developing and fixing solutions for all developing and fixing are done on the top floor. The analytical laboratory is next to the solution room, and the chemical supervisor is responsible for solution mixing. All developers are mixed in batches which are tested and approved before blending with the large main supply storages. This gives maximum uniformity by minimizing any changes from batch to batch. Standard fresh fixer solutions are prepared for a limited amount of standard sensitometric testing, but the bulk of the work is done with regenerated fixer.

After processing, the dry films are delivered to the reading, calculating, and inspection room. Here they are read on stroboscopic photoelectric densitometers⁹ which have been previously described before the Society. These instruments are direct reading and are

extremely rapid. They are used for reading both continuous exposures and sensitometric strips. An automatic electric calculator, operating in conjunction with the recording typewriter of the stroboscopic photoelectric densitometer, calculates the gamma during the reading of the sensitometric strip. By this means, all subjective errors in determining density and gamma are eliminated. A paper is being prepared on the automatic electric calculator by Dr. D. R. White of the Research Division of the du Pont Photo Products Department.

When all the data on an emulsion have been collected and studied by the product supervisor, he recommends its release and sends a summary of results to the control superintendent. Release sheets are then issued which permit the material to be placed in stock ready for shipment. A continuous, up-to-date, tabulated record of data, whether sensitometric, physical, chemical, or mechanical, is kept on all products. The new du Pont control laboratory is producing the precision results which are of first importance to both the manufacturer and the consumer whose common interests lie in the quality and reliability of the raw stock.

REFERENCES

¹ GITTERMAN, H.: "A New Electrostatic Air-Cleaner and Its Application to the Motion Picture Industry," *J. Soc. Mot. Pict. Eng.*, **XXXIX** (July, 1942), p. 70.

² WHITE, D. R.: "Drying Conditions and Photographic Density," *J. Soc. Mot. Pict. Eng.*, **XIX** (Oct., 1932), p. 340.

³ KELLEY, G. A.: "Air-Conditioning with Lithium Chloride," *J. Soc. Mot. Pict. Eng.*, **XXX** (Apr., 1938), p. 422.

⁴ WAR MANPOWER COMMISSION: "War Production Trainer's Manual; prepared by New Jersey War Production Training Consultant's Panel, Training within Industry Division, War Manpower Commission, in collaboration with Vocational Division of the New Jersey Department of Public Instruction and Rutgers University Extension Division (1942).

⁵ JONES, L. A.: "Photographic Sensitometry, Part I," *J. Soc. Mot. Pict. Eng.*, **XVII** (Oct., 1931), p. 491.

⁶ WHITE, D. R.: "Two Special Sensitometers," *J. Soc. Mot. Pict. Eng.*, **XVIII** (Mar., 1932), p. 279.

⁷ JONES, L. A.: "A Motion Picture Laboratory Sensitometer," *J. Soc. Mot. Pict. Eng.*, **XVII** (Oct., 1931), p. 536.

⁸ JONES, L. A., RUSSELL, M. E., AND BEACHAM, H. R.: "A Developing Machine for Sensitometric Work," *J. Soc. Mot. Pict. Eng.*, **XXVIII** (Jan., 1937), p. 73.

⁹ WHITE, D. R.: "A Direct-Reading Photoelectric Densitometer," *J. Soc. Mot. Pict. Eng.*, **XXXIII** (Oct., 1939), p. 403.

IMPROVEMENT IN ILLUMINATION EFFICIENCY OF MOTION PICTURE PRINTERS*

C. J. KUNZ, H. E. GOLDBERG, AND C. E. IVES**

Summary.—Motion picture printers now in common use were designed to be operated at a moderate running speed with a single type of film of such emulsion speed that ample exposures were obtained by the use of low-wattage tungsten lamps. Recently the use of a variety of fine-grain films has made necessary greater exposure intensities. Tungsten lamps of higher wattage or mercury-vapor lamps have satisfied the need for increased light intensity in some cases, but have not been found practicable for use in others.

Greater optical efficiency is needed in many of the printers. This can be obtained by the use of light-collecting systems involving the use of either condensers or reflectors. Some special problems are introduced by the peculiarities of the mechanical arrangements of the printers and sometimes by the requirement of uniformity of illumination, both at the printing aperture and at the light-change aperture.

Examples showing the application of condenser and reflector systems to 2 typical printers are given with a detailed description of the optical design as well as of the mechanical problems encountered. Data are given on the increase in illumination efficiency obtainable in practice.

Many of the printers now in use were designed at a time when running speeds were moderate and the characteristics of the film in use required no greater intensity of illumination than was provided by low-wattage tungsten lamps located at distances up to a foot from the printing aperture.

The present extensive use of a variety of fine-grain films requiring more exposure, coupled with the tendency to reduce exposure time by the adoption of higher running speeds, necessitates an increase of illumination intensity by a factor of 5 to 20 or more times in various instances.

Means Available for Obtaining Increased Illumination.—The extent to which intensity of the illumination can be increased by moving the light source nearer to the film is limited in some cases by the presence of mechanical obstructions and, in others, as a

* Presented Oct. 29, 1942, at the Technical Conference in New York.

** Kodak Research Laboratories, Rochester, N. Y.; Communication No. 962.

consequence of the requirement of uniformity of illumination in an exposure-control aperture rather distant from the printing aperture.

Means which can be used with some degree of satisfaction for increasing the intensity of illumination substantially may be classified as follows:

- (1) The use of tungsten lamps of higher wattage.
- (2) The use of a more efficient illuminant such as a projection-type lamp or the capillary-type mercury-vapor lamp.
- (3) The use of more efficient optical systems.

Lamps of higher wattage dissipate more heat and are likely to overload existing sources of regulated power. Also, changing to a lamp of higher wattage may in certain cases necessitate rewiring or replacing the rheostat light-change equipment.

Some gain may be obtained by the second method if, for example, a cage filament lamp is replaced by one of the projection type. In a typical case, the increase in illumination in the direction perpendicular to the plane of the filament array may be of the order of 50 per cent for equal wattage when the projection lamp is run sufficiently below the rated voltage to give comparable filament temperature and lamp life.

The capillary mercury-vapor lamp requires a much more complicated method of starting and control than a tungsten lamp and can not be used with a rheostat light change. Furthermore, the radiation quality characteristic of the low- and medium-pressure mercury-vapor lamps, though very efficient, has the effect of reducing photographic contrast and altering tone reproduction in a way which is sometimes objectionable. Some data relative to the effectiveness of mercury lamps are given in a later section.

The third means, that of increasing the efficiency of the printer optical system, avoids these objections and will be considered further.

In this paper attention is centered on the contact printer, although some of the means considered here can be applied to projection printers.

Uniformity Requirements.—The illuminating systems of some printers consist simply of a lamp located at a distance of some 6 to 10 in. from the printing aperture either with or without a ground-glass diffusing screen in the light path. The uniformity of exposure is usually satisfactory, but less than 1 per cent of the total light output of the lamp reaches the printing aperture.

Increased efficiency can be obtained by the installation of some type of mirror or lens system which has the effect of providing a new light source of practically the same brightness as the lamp filament and larger angular dimensions when viewed from points within the printing aperture.

The choice of optical systems and, in consequence, the increase in efficiency attainable are limited in practice by the necessity of satisfying certain requirements for uniformity of illumination in the printing aperture and at a second aperture, in addition, if a diaphragm light change is used.

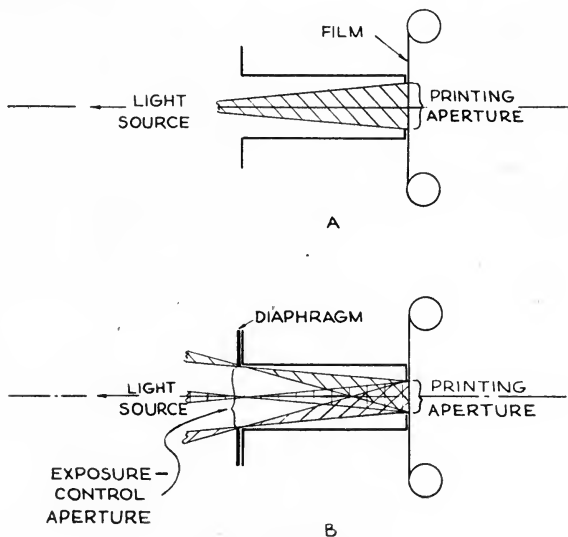

FIG. 1.

Uniformity at More Than One Aperture.—Printers in which exposure modulation from scene to scene is obtained by changing the lamp current or by using a variable-density matte, usually require uniformity at the printing aperture only, as illustrated diagrammatically in Fig. 1A. In certain printers equipped with diaphragm or variable-width traveling-matte controls (Fig. 1B), it is required in addition that the light flux transmitted to all portions of the printing aperture be the same for equal elements of area uncovered by such diaphragms in any portion of the exposure-control aperture. These conditions will be referred to later as Type *A* illumination and Type *B* illumination, respectively.

Fig. 1 also illustrates the fact that the illumination usually reaches the printing aperture through a long, narrow tunnel which can not be eliminated from existing printers because of the presence of a sprocket or other film-transport mechanism. The exposure-modulation aperture, if present, will be considered to be several inches from the film, as indicated in the drawings. Cases in which it is located very near the printing aperture are less common but actually must be considered to be of either Type *B* or Type *A*, according to the nearness. The location of the elements of an optical system and the dimensions of some of them are usually restricted by the existence of the tunnel.

Direction of Uniformity.—In order to obtain uniform exposure in a continuous printer, it is sufficient that illumination in the

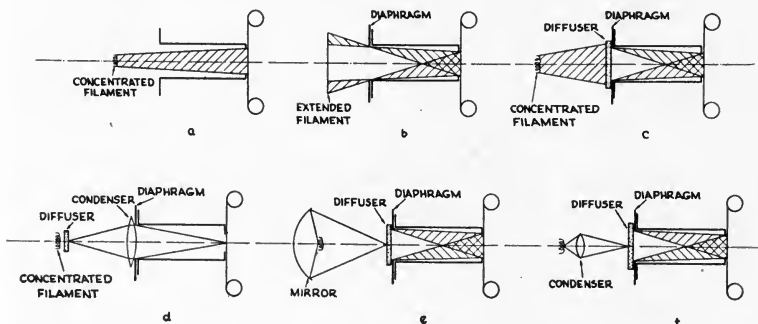

FIG. 2.

printing aperture be uniform in a direction transverse to the strip of film, but in a step printer it must be uniform longitudinally of the film also. In discussing various optical systems, the direction in which uniformity is required in any aperture will be designated as transverse to or longitudinal of the film. Thus, with Type *B* illumination, a diaphragm moving longitudinally with respect to the film strip would require uniformity in its aperture only in the longitudinal direction. An iris or cat's-eye diaphragm similarly located will operate effectively if the illumination is uniform both longitudinally and transversely.

Unaided Light Source (Type *A* Illumination).—Type *A* illumination is given by almost any lamp without a diffuser or other optical aid. Except for the effects of shadows cast by imperfections in the glass envelope of the lamp, and for reflections from the walls of the

tunnel, both transverse and longitudinal uniformity are provided at the printing aperture. It is evident, however, that such a system (Fig. 2a) is unsuitable for printers requiring Type *B* illumination. As stated before, the efficiency of illumination is very low.

Unaided Extended Light Source (Type *B* Illumination).—In order to have Type *B* illumination without additional optical elements, the scheme shown in Fig. 2b can be used. The lamp has a uniform extended filament structure along one axis and must be positioned so that the filament completely fills the exposure-control aperture, either longitudinally or transversely as required, when viewed from any position in the printing aperture. Then, as the diaphragm is moved across the exposure-control aperture, the effective length of the filament decreases, thus reducing the amount of light reaching the printing aperture in proportion. Uniformity, at least on the axis chosen, is insured at the exposure-control aperture, while both longitudinal and transverse uniformity are obtained at the printing aperture except for possible effects of reflections and shadows formed by the lamp. Obviously, this illumination system can be used also in printers in which Type *A* illumination is acceptable. As in the case discussed before, the efficiency is usually below 1 per cent.

Light Source with Diffuser.—The effect of shadows from blemishes in the glass lamp envelope can be minimized by inserting a diffuser, such as a sheet of ground glass, between the lamp filament and the printing aperture. The diffuser then becomes a secondary light source. If the Type *B* requirements must be satisfied, the diffuser is best located close to the adjustable diaphragm, as shown in Fig. 2c.

The 3 systems discussed so far constitute the least efficient class. The concentrated filament-type source with a diffuser located at the tunnel entrance will be taken as a basis of reference for comparison with other methods to be discussed.

Simple Lens with Diffused Secondary Light Source.—A very great increase in illumination could be obtained by forming an image of the light source in the printing aperture but this is not practicable because of the nonuniformity of available light sources. A worth-while gain can be made, nevertheless, by the use of a modification of this scheme in which a diffuser placed closely enough to the lamp to be illuminated intensely is imaged in the printing aperture by a lens (Fig. 2d). The diffusion should be sufficient to hide the lamp filament pattern without causing an excessive light loss. A projec-

tion lamp with as small an envelope diameter as possible should be used.

Since the illumination intensity depends on the cone angle of the light beam falling on the printing aperture, the use of a lens of large diameter located close to that aperture is favorable. Opposed to this are limitations set by the relative apertures that are attainable in practice and the existence of the tunnel. For a given lens, the largest possible cone angle is attained if the diffuser and lens are placed at such distances that an image of the largest area of diffuser, having acceptable brightness uniformity, just fills the printing aperture. The focal length of the lens chosen in a given situation depends on the sizes and distances involved.

If only the Type *A* illumination is necessary, the lens may be located in the tunnel, but other considerations may oppose this. For printers requiring Type *B* illumination, longitudinal and transverse uniformity at both the exposure-control and the printing apertures can be obtained if the lens is close to the former. The intensity can be increased by a factor of 3 to 5 times in a typical situation, as compared with the first 3 cases described.

Spherical Mirror with a Concentrated Light Source.—A system which is capable of giving greatly increased efficiency is shown in Fig. 2*e*. It makes use of a spherical mirror to project an enlarged image of a concentrated-filament light source on a ground-glass diffuser. In the case of Type *A* illumination, the position of the diffuser assuring greatest efficiency is as close to the printing aperture as the uniformity requirements at that aperture permit. However, if the diffuser is located in a tunnel, no advantage can be gained beyond the position where a significant part of the light from the mirror begins to be cut off by the walls of the tunnel. The focal length of the mirror should be chosen in accordance with dimensions of the tunnel and lamp house as well as those of the lamp, so as to form an image of the desired size on the diffusing glass. The diameter of the mirror should be large because the brightness of the image formed on the ground glass depends on its relative aperture. It should be noted, however, that because of the light distribution characteristics of a ground glass diffuser, illumination reaching it at large angles of incidence falls mainly outside the printing aperture where it is lost. Consequently, the increase in illumination produced at the printing aperture by using larger relative apertures may be less than would otherwise be expected.

For Type *B* illumination, the diffuser must be located close to the exposure-control aperture, as illustrated in Fig. 2*e*. The filament coils of a projection lamp are imaged by the mirror close to the ground-glass diffuser at such magnification that the height of the image just exceeds that of the wide-open aperture. With a vertical-coil lamp filament, only longitudinal uniformity exists at the exposure-control aperture, but both transverse and longitudinal uniformity are provided at the printing aperture if the diffusion is sufficient.

The efficiency of illumination is increased by a factor of 20 or more with this system as compared with the first 3 cases. This large increase in illumination is attained because a considerably enlarged image of the filament is formed at a shorter distance from the film. The degree of improvement would be far less if the mirror were used as it is commonly with condensers to form an interlaced image of the filament coils at unit magnification in the filament plane.

Single Lens with a Concentrated Light Source.—A system closely related to the one just described makes use of a single condenser lens, as shown in Fig. 2*f*, instead of the mirror. The same considerations regarding the selection of the lens and the position of the various elements of the system, as described in the preceding section, apply here. The maximum efficiency of a system of this type is commonly about $1/2$ of that attainable by the use of the mirror system because of lower relative aperture.

Lens Relay Systems.—The systems for increasing the illumination described so far make use of either extended light sources or diffusing elements. Diffusers are wasteful of light and can be avoided if a lens system is employed in such a way as to provide uniform illumination at the printing aperture.

It is well known that the photometric properties of any optical system are fixed if the size and location of two sets of conjugated apertures, called *aperture stops* and *field stops*, respectively, are specified. In general, one of these sets is formed by all the cross sections of the optical path which are uniformly filled with light, while the other system consists of the light source and its images. Efficient light sources usually lack brightness uniformity.

Type A Illumination.—If uniform illumination of only one plane in the printer is sufficient, a relay optical system like that shown in Fig. 3*a* is satisfactory. The condenser lens L_1 (field stop) forms an image of the light source on the objective lens L_2 (aperture stop). The latter, in turn, forms in the printing aperture an image of L_1 which

is uniform in brightness. Except for losses by absorption and stray reflection of light in the optical system, the over-all effect of the lenses is equivalent to replacing the actual light source by an imaginary light source of the same brightness but larger and located at L_2 . For best results, the filament image should therefore be large and as close to the printing aperture as is compatible with uniformity requirements imposed by the inverse square and cosine laws. The effect of dirt specks on the condenser surface L_1 can be minimized by imaging on the film not the surface itself but some other cross section of the light beam slightly removed from it; it must be recognized, however, that the lens diameter necessary to attain a given optical efficiency is smallest if the aperture and field stops are located at the objective and condenser lenses, respectively.

Type B Illumination.—Since all *effective* stops in a system must belong to either one of the 2 families, and since all apertures of each set

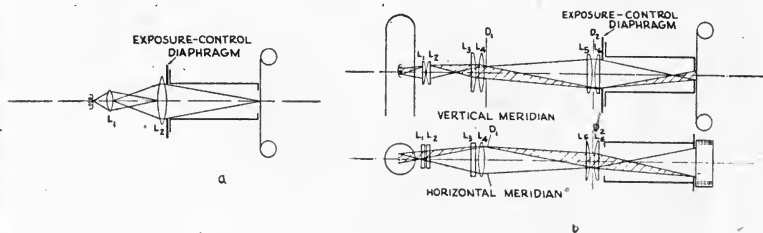

FIG. 3.

are optically conjugated, the exposure-control aperture and the printing aperture must be parts of different systems of stops if Type *B* illumination is required. With tungsten-filament lamps, the relay condenser, as ordinarily used, provides uniform illumination in one system of stops only. The other set which is conjugate with the light source shares its nonuniformity. It has always been considered inevitable that evenness of illumination in this other family of stops should be obtained only at the cost of reduction in efficiency by the use of special light sources or the insertion of diffusers.

In the special case where the uniformity required is in one direction only at each of the 2 printer apertures, and in mutually perpendicular directions, this loss in efficiency can be avoided by the addition of a cylindrical condenser to the simple relay system just discussed. Typical of this case is a continuous printer in which uniformity is required only in the longitudinal direction at the exposure-control

aperture and only in the transverse direction at the printing aperture. A sphero-cylindrical system providing this type of illumination is shown in Fig. 3*b*. It has been arranged so that the light source and its image are field stops in one meridional section of the beam and aperture stops in the other.

In Fig. 3*b* (vertical meridian), the cylindrical condenser L_1L_2 serves as the vertical aperture stop. It is uniformly illuminated by the light source and imaged by lenses L_3L_4 onto the exposure-control aperture D_2 providing vertical (longitudinal) uniformity there. An image of the light source is formed by L_1L_2 on D_1 (field stop) and relayed onto the film by L_5L_6 . The horizontal meridian shows that in that section of the beam L_3L_4 is uniformly illuminated and imaged by L_5L_6 onto the printing aperture assuring horizontal uniformity there, whereas an image of the light source (horizontal aperture stop) is formed on D_2 .

By comparison with the first 3 cases, relay systems are capable of improving the optical efficiency by a factor of some 10 to 30 times.

Needed Gain in Efficiency in Existing Printers.—If the time of exposure is to remain constant, the necessary increase in intensity of illumination will be in proportion to the increase in exposure required by the use of slower films, filters, and so forth. Comparisons may be made with the older type of positive film, such as Eastman Release Positive Film Type 1301, which required the equivalent of about 20 meter-candle-seconds' exposure to 2850 K tungsten as a maximum. Films of speed similar to Eastman Fine-Grain Release Positive Film Type 1302 ordinarily require 100 to 150 m-c-s with tungsten illumination of the same quality, or a 5 to 7 times increase depending upon development conditions, and as much as 300 m-c-s, or a 15 times increase, if a Corning No. 5840 ultraviolet filter is to be inserted for sound printing. Certain duplicating films, such as Eastman Fine-Grain Duplicating Positive Film, need about 2500 m-c-s, or 125 times as much as the older type of release positive film. Exposures given in the following sections in meter-candle-seconds refer to tungsten at a color temperature of 2850 K.

Application of More Efficient Optical Systems to Current Printers.—Two printers representing distinctly different types, both of which are commonly used in printing today, are the Duplex step printer and the Bell and Howell Model *D* continuous printer. The illuminating system of the former consists merely of a lamp, a shutter for interrupting the light beam during the film pull-down, a tunnel,

and a film-exposure aperture. This printer is typical of those requiring Type *A* illumination with both transverse and longitudinal uniformity at the film aperture.

The Bell and Howell Model *D* continuous printer of the later type is representative of those requiring Type *B* illumination. Essentially, the optical system consists of a lamp, a ground-glass diffuser close to an adjustable diaphragm which moves longitudinally, and the printing aperture. The sides and hub of a large sprocket used to drive the film form a narrow tunnel through which light must pass. Only transverse uniformity is required at the printing aperture, and only longitudinal uniformity at the exposure-control aperture.

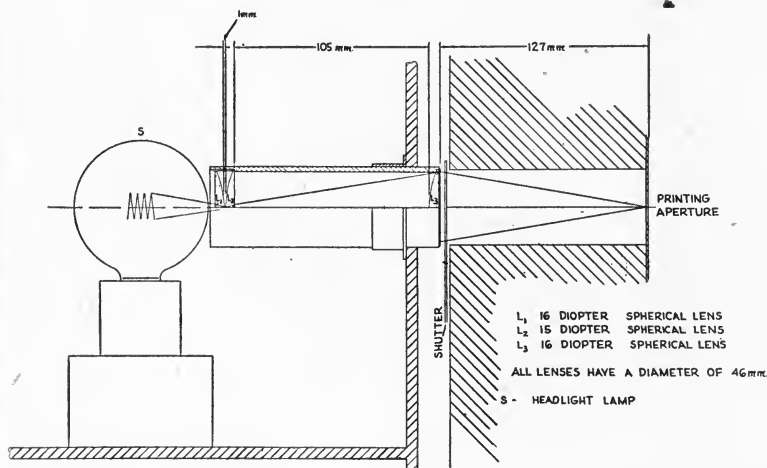

FIG. 4.

In the following sections, various ways of modifying the illuminating systems of these printers to provide a desired increase in exposure are described. Further examples would present few fundamental differences and, in any case, would call for treatment according to the principles which have been discussed. If an existing printer is equipped with some type of condenser or mirror system, the systems described here could not, in most cases, be added but could be used if replacement or modification were contemplated.

Relay Condenser System Applied to the Duplex Printer.—A relay system which has been designed for use in a Duplex printer is shown in Fig. 4. In order to avoid altering an existing light-change

rheostat, the 100-w spotlight lamp which has a large spherical envelope was retained.

All the lenses are mounted in a single tube with the objective lens L_3 located as near to the shutter as possible on the side toward the lamp. The focal length of the condenser lens combination L_1L_2 is such as to form an image of the filament as large as possible in the objective lens, the diameter of which is limited by the size of the tunnel opening. The size of the filament and the diameter of the lamp bulb

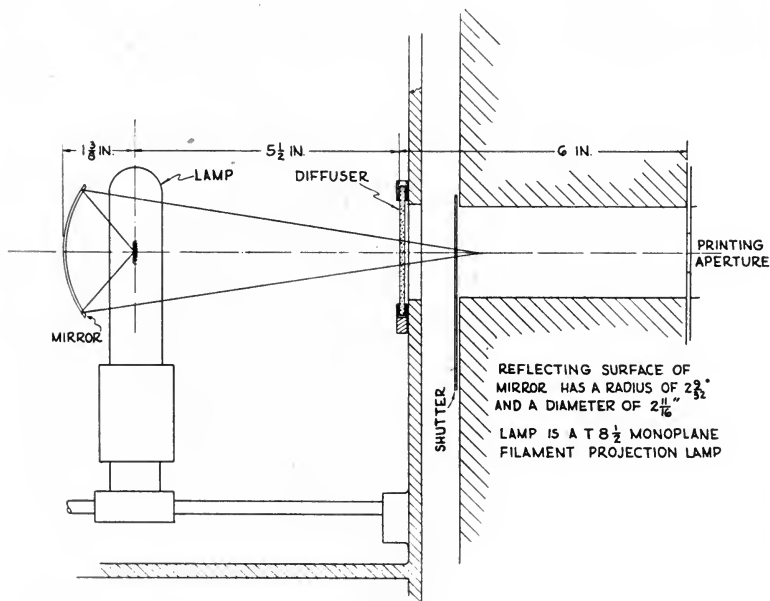

FIG. 5.

are controlling factors in the present case. The focal length of the objective L_3 is determined by the length of the tunnel and the position of the condenser L_1L_2 . The diameter of L_1L_2 is such as to provide a sufficiently large image at the printing aperture.

An increase of illumination by a factor of at least 8 times is obtained. Greater intensity could be obtained with a tubular lamp of smaller envelope diameter by making the proper adjustment of the lens constants.

The use of a spherical mirror to form an interlacing filament image among the filament coils would increase the efficiency of this system,

but this is not recommended because the illumination would change markedly with sagging of the filament. A biplane filament lamp is the most effective type. As pointed out before, in this system dirt, scratches, and blemishes on the condenser must be avoided as sources of uneven exposure because they are imaged on the film.

Spherical Mirror in the Duplex Printer.—For the cases where a projection-type lamp can be employed, the mirror system, illustrated in Fig. 5, increases the efficiency of illumination satisfactorily. The lamp is positioned so that the center of its filament is in line with the axis of the tunnel. For the printer in question, the mirror dimensions

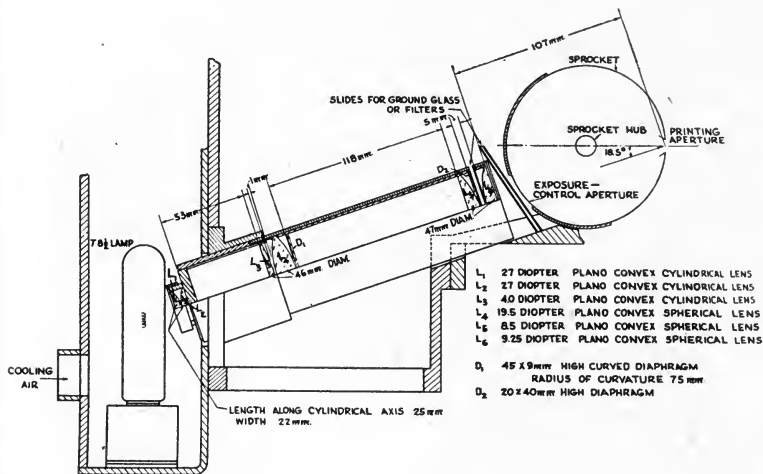

FIG. 6.

given in Fig. 5 represent the best choice in a commercially available series. The focal length is short enough for high efficiency but long enough to afford ample latitude in lamp size and for adjustment. A medium fine ground-glass diffuser of the type used in focusing camera-backs is mounted in a slotted frame at the entrance of the tunnel. It is satisfactory to mount the mirror in a fixed position and to make small adjustments to obtain maximum intensity of illumination by moving the lamp mount along the optical axis as provided in this type of printer. The use of a photocell exposure meter at the printing aperture is helpful in adjusting for maximum illumination intensity.

The maximum exposure obtainable with this system is about 30 times that given by a simple extended cage-filament lamp of equal wattage used in combination with a diffuser. A 50-w, 115-v projection-type lamp, operating at about 100 v, used in this system provides in 0.14 sec an exposure of 2500 m-c-s, which is sufficient for printing the very low-speed duplicating films. The illumination can be reduced by moving the lamp so as to enlarge the filament image to such a degree that part of it is masked off by the tunnel. To print the faster fine-grain release positive films without disturbing the adjustment, it is necessary to reduce the illumination by decreasing the lamp current, or by inserting additional diffusers, diaphragms, or light-absorbing screens at the entrance to the tunnel.

Relay System in the Bell and Howell Model *D* Printer.—A spherocylindrical relay system suitable for use in a Bell and Howell Model *D* printer is shown in Fig. 6. As in any relay system, the objective lens should be located as close to the printing aperture as possible to obtain highest efficiency. However, in order to have the whole optical system in a simple lens barrel which can be inserted through an opening in the back of the lamp house, the objective is placed, in the present instance, directly back of the exposure-control aperture. The diameter of this objective is large enough to pass, without vignetting, all light beams necessary to fill the exposure-control aperture at the wide-open setting.

The power of the cylindrical condenser lenses L_1L_2 depends upon the type of light source used. It must be such that the final image of the lamp filament produced in the vertical meridian by the cylindrical condenser L_1L_2 in combination with objective L_5L_6 fills the printing aperture completely, with an extra margin for possible misalignment of the lens barrel in the printer.

The focal length of the spherical lens L_4 should be short enough to produce an image of the light source sufficiently large to fill the exposure-control aperture in the horizontal meridian; but at the same time long enough to allow the cylindrical lenses L_1L_2 to form an image of the light source at D_1 .

The lens L_3 is a weak cylindrical lens supplementing the power of L_4 in the vertical meridian to bring L_1L_2 to focus at the exposure-control aperture. The lenses L_1L_2 must be of such width that their image covers that aperture and the sizes of L_3L_4 and D_1 are calculated to fill the printing aperture similarly. As shown in Fig. 3, the diaphragm D_1 is curved in the horizontal meridian to compensate

for the curvature of field of the objective lenses L_5L_6 , thus producing a substantially flat image at the printing aperture.

As it is desirable to keep the power of the cylindrical elements L_1L_2 as low as possible, a lamp with a filament composed of comparatively long coils should be selected. In the particular application discussed here, the power of the lamp is limited to 100 w, and the $CI3-T8^{1/2}$ prefocus projection lamp is considered acceptable. A similar lamp with a $CCI3$ filament could be substituted if necessary but, because of the shorter coil length of this type of filament, the vertical adjustment of the lamp would be critical. In addition, the coiled-coil lamps are less satisfactory for this use because of the tendency of adjacent coils to short circuit with consequent shifting of intensity. There are a number of suitable lamps of higher wattage and most of them could be used if a slight change of the cylindrical condenser L_1L_2 was made to allow for a larger diameter lamp envelope. If no restrictions regarding voltage or power are imposed, the 50-v, 200-w biplane lamp should prove particularly advantageous, because its image would fill the exposure-control aperture more completely, and because its straight rugged coils are well suited to serve as a light source in a cylindrical lens system.

All lenses may be made of spectacle crown glass, and felt-polished surfaces are entirely satisfactory. A variation of ± 1 diopter in the power of L_1 and L_2 , and of $\pm 1/8$ diopter of all other lenses can be tolerated.

The optical parts are mounted in a tube, as shown in Fig. 6, and the tube, in turn, is supported by a bracket carrying the new lamp house. In order to avoid a cumbersome construction, a small lamp house with forced air cooling is used. It is necessary to make an opening in the rear wall of the printer and in some printers to mill out part of the ledge shown by the broken lines in Fig. 6 to provide clearance for the lens tube. It is also advisable to mill flat a portion of the rear wall of the regular lamp house around the opening. The optical system may then be mounted on a plate, as illustrated in Fig. 6, and secured with pins and screws.

With this construction, the position of lamp and lenses in the printer is so well determined that either the whole assembly or the lamp alone can be removed and put back whenever desired without needing readjustment or recalibration.

As is usual with systems which form an image of a lens or diffuser surface at or near the printing aperture, precautions must be taken to

insure clean lens surfaces. In this system all such surfaces are enclosed in the tube except that nearest the lamp, which can easily be kept clean, and that closest to the exposure-control aperture which is not critical in this regard. Dirt or scratches on the lens L_3L_4 are imaged in the printing aperture, while dirt or scratches on the surfaces of the lenses L_1L_2 may result in faint streaks on the film.

Tests in the printer have shown that the logarithmic step increment is uniform.

This system increases the efficiency of illumination about 30 times so that sufficient exposure is provided by the 100-w lamp for printing all films except the slowest duplicating films at a running speed of 94 ft a min with a $\frac{5}{16}$ -in. printing aperture (about $\frac{1}{60}$ sec). Under these

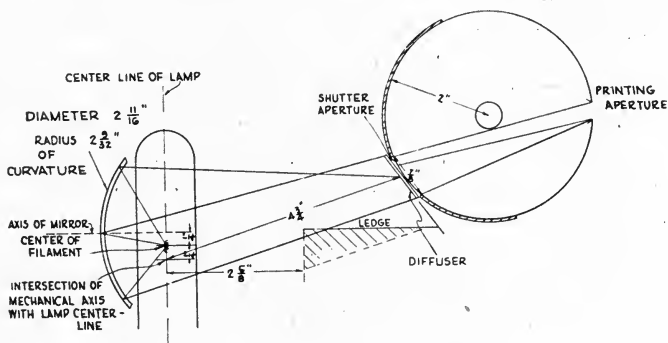

FIG. 7.

conditions a 100-w, 115-v lamp operated at 100 v gives an exposure of about 560 m-c-s.

For ultraviolet radiation, the efficiency is reduced somewhat. With a spectacle crown system of this type, the loss is about 20 per cent.

Spherical Mirror in the Bell and Howell Model D Printer.—In using a spherical mirror in a Bell and Howell Model D printer, the optical path can be arranged in such a way as to avoid removing the ledge shown at a point between the lamp and the exposure-control aperture in Fig. 7. For this installation, the lamp chosen was the 100-w, $T-8\frac{1}{2}$ projection type.

The normal position of a lamp filament is at the intersection of the center line of the lamp house and a line passing through the center of the printing aperture and the wide-open exposure-control diaphragm opening. The lamp axis is vertical. In order to clear the obstructing

ledge the mirror is placed somewhat above the center line of the apertures. A satisfactory adjustment is obtained with the lamp $\frac{1}{4}$ in. above its normal position just described and with the mirror axis on a horizontal line $\frac{1}{4}$ in. above the center of this new filament position. The center of the mirror is about $1\frac{1}{4}$ in. from the plane of the lamp filament. When the elements are displaced vertically in this way, it is disadvantageous to have the lamp axis perpendicular to the axis of the mechanical apertures. Slightly greater efficiency might be attained by cutting away the obstruction and putting the lamp and mirror on the mechanical axis and in the normal angular alignment to it, but this involves more work.

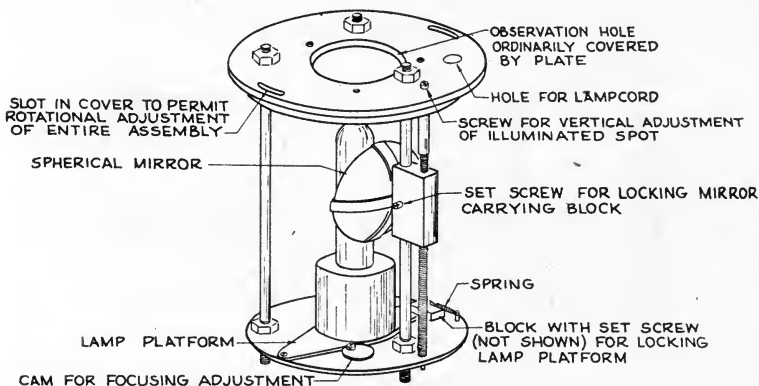

FIG. 8.

After the elements are mounted, adjustments are made by trial to obtain the highest efficiency consistent with fulfillment of the Type *B* condition. A satisfactory adjustable mounting is shown in Fig. 8. The upper plate in this assembly takes the place of the regular lamp house cover and provides a support for the remaining parts with necessary holes for inspection and adjustment.

The beam is focused on the diffuser located in front of the exposure-control aperture by moving the lamp on its supporting platform. Vertical adjustment of the image is obtained by rotation of the adjusting screw which passes through the mirror-carrying block, and horizontal adjustment is given by rotation of the entire assembly.

Since longitudinal uniformity alone is demanded at the exposure-control aperture in the Model *D* Bell and Howell printer, the images of the vertical filament coils must be magnified sufficiently to fill the

wide-open aperture uniformly from top to bottom. The image need not be focused sharply on the ground-glass diffuser. Special care must be taken to avoid any falling off in intensity near the upper or fixed jaw of the diaphragm because this would cause serious variations in the exposure intervals at the low-exposure end of the diaphragm range. When the light beam is correctly adjusted, the appearance of the ground-glass diffuser, viewed from the printing aperture, is as shown at the left in Fig. 9. Any residual nonuniformity consists of vertical elements rather than of horizontal elements, such as those at the right in Fig. 9. Excessive magnification is to be avoided because all light which falls outside the tunnel opening is lost.

When adjustments are made as indicated, the logarithmic exposure increment from step to step is acceptably uniform through the range.



FIG. 9.

Only a slight falling off is found toward the high-exposure end—about the same as that in the original printer illumination system when a concentrated filament lamp and diffuser are used. Uniformity of illumination in the printing aperture is not impaired by the use of the mirror.

Increase in Intensity Obtained.—By the use of this mirror in the manner described, an exposure of approximately 1100 m-c-s (0.016 sec exposure time) is obtainable with careful adjustment, using a 100-w, 115-v lamp operating at 100 v. This is more than 60 times as intense illumination as is given by the same lamp without the mirror. A 40 times increase is easily obtained.

If the method of mounting is equivalent to that illustrated in Fig. 8, the lamp and reflector units from all printers of the same model in a plant can be set up and adjusted on a special gauge duplicating the essential elements of a printer or, as an alternative, one of the printers can be used as a gauge.

Mercury-Vapor Illumination.—Although the use of mercury-vapor lamps for printers has certain objections, the increase in efficiency with respect to heat dissipated and power consumed is considerable. For instance, an 85-w *BH-8* lamp, modified so as to operate at 140 w with forced air cooling, produces approximately 3.2 times as great effective intensity in printing noncolor-sensitized films as a tungsten projection lamp of equal wattage operating at 2850 K color temperature. Furthermore, the difference in the spectral energy distribution of the two lamps is such that through an ultra-violet filter of the Corning 5840 type approximately 30 times as much wattage is required with the tungsten lamp at 2850 K to equal the effect of the mercury-vapor lamp. In practice, however, the necessary exposures are easily obtained with a 100-w tungsten lamp by the use of certain of the optical systems described to increase the illumination efficiency.

GENERAL RECOMMENDATIONS

The gain in illumination for unfiltered tungsten produced in the most important practical cases is shown in Table 1. Obviously, if the increase in intensity required is greater than is obtainable by increasing the optical efficiency, other changes must be made in addition. The type of system chosen will depend upon the maximum increase in efficiency necessary as well as the degree of uniformity (uniaxial or biaxial) required, and the number of apertures in which uniformity is required. Thus, if uniformity is necessary at the printing aperture only, a wider selection may be available. To some extent the choice may be influenced by the type and scale of operations in the laboratory, and by a consideration of the materials and facilities available for making the modifications.

In a large laboratory where a number of printers are to be equipped, it is profitable to make a greater investment at the time of installation to eliminate expense in keeping the units standardized and adjusted. If only one printer is to be equipped, it may be preferable to use a system which entails a lesser expenditure for parts and less drastic alterations of the printer, and to devote some additional effort to maintenance.

There is no fundamental reason why one of these systems should not perform satisfactorily for either sound or picture work. If frequent shifts are made from one type of work to another, necessary adjustments in illumination level can usually be brought about by in-

TABLE I

Time of Exposure	Illumination*	Maximum Exposure (Meter-Candle-Seconds)	Increase in Exposure Factor	Increase in Exposure Logarithmic Increase
0.14 sec	<i>Duplex Printer</i>			
	60-w cage filament lamp. No diffuser (2340 K).	100		
	50-w projection-type lamp with spherical mirror and ground-glass diffuser (2850 K).	3200	30X	1.5
Unknown	100-w projection-type lamp with spherical mirror and ground-glass diffuser (2850 K).	7680	75X	1.9
	100-w spotlight-type lamp. No diffuser. 100-w spotlight-type lamp used with spherical lens relay system.		$\geq 8X$	≥ 0.9
0.016 sec (wide-open diaphragm setting)	<i>Bell and Howell Printer—Model D</i>			
	100-w projection-type lamp with ground-glass diffuser.	18		
	100-w projection-type lamp with spherocylindrical relay. No diffuser.	560	30X	1.5
	100-w projection-type lamp with mirror and ground-glass diffuser.	1100	60X	1.8

* In this table the lamps described were of the 115-120-v type and were operated at 100 v. Factors of exposure increase are applicable only within the respective brackets. However, all exposures in meter-candle-seconds can be compared directly.

serting diffusing or absorbing screens at suitable points. Due care must be taken, of course, to avoid introducing undesired diaphragming or other image pattern.

Choice of Lamp.—In some systems which form an image of the lamp, the dimensions of the filament array are fixed when the lens constants are chosen. If possible the design should not require the use of lamps which have objectionable features for use in printers. Biplane filament lamps, if available in the power rating desired, will perform satisfactorily in most of the systems, as mentioned previously.

ACKNOWLEDGMENT

The authors are indebted to Dr. O. Sandvik for suggestions and advice and to Mr. F. E. Altman for assistance in the selection of mirrors.

DISCUSSION

In the discussion following presentation of this paper 2 additional methods of illumination were considered which deserve some comment here.

It was suggested that the lamp house be made to act as an integrating sphere. The printing aperture would be located in the wall of the sphere. A worth-while increase in illumination could be obtained with this arrangement, especially if direct radiation from the lamp could reach the film.

Unfortunately, the presence of the tunnel in existing printers precludes meeting the conditions necessary for obtaining full advantage of the device. When the lamp is in line with the tunnel, specular reflections from the tunnel walls must be suppressed. Illumination received at the tunnel entrance includes extreme angles of incidence so that the tunnel walls must be highly reflecting and without any gaps where losses might occur. Considerable alteration would be necessary to close openings around shutters, sprockets, *etc.*, in the existing printers. If direct rays from the lamp were eliminated by displacing it and using a baffle, the illumination would be greatly reduced. The attainment and maintenance of a complete covering of highly reflecting surface on the inside of the lamp house is essential, but would be difficult. On the whole, this scheme does not appear to hold much promise.

An integrating bar might be used to carry the light through the tunnel. In most cases, however, the tunnel is not appreciably wider

than the printing aperture and the bar would have to extend to within a short distance of the film. Dust on a glass surface so close to the film would almost certainly cause shadows.

A quite different suggestion was that the image of the surface of a ribbon filament lamp be formed directly upon the film being printed. Aspheric optics would be used to modify the shape of the image of the long narrow filament. For high efficiency, a large portion of the filament should be used, but this can not be done because of large variations in temperature at the edges and ends of the ribbon which would cause serious unevenness in exposure. The use of a broad filament to minimize loss at the edges would aggravate the mechanical difficulties inherent in this type of filament and entail troublesome extremes of low voltage and high current. Ribbon filaments must be run at low temperature and, therefore, low efficiency of radiation. Consequently, it appears more advantageous to use the coiled filaments with some device to eliminate the unevenness.

A SIMPLIFIED VARIABLE-DENSITY SOUND NEGATIVE DEVELOPER*

PAUL ZEFF AND S. J. TWINING**

Summary.—*A variable-density sound negative developer composed of Metol, borax, and sulfite is described. That such a sound negative developer is possible, is shown by a preliminary survey of the literature pertaining to hydroquinone-Metol activity at low pH values. In a developer so constituted and coupled with an adequate replenisher system, the oxidation factor is practically negligible and results in a stable pH value which in turn permits the elimination of the usual buffering agents. The value of such a developer is that it permits greater simplicity of chemical control and results in some economy.*

Sensitometric data obtained from the operation of this developer show a negative H and D characteristic of maximum linear latitude, and normal printing characteristics. Gamma-density relationship is very stable during continuous negative developing runs, thus making possible quantity production of sound negatives of uniform density.

A review of the literature pertaining to the practical and theoretical aspects of photographic development shows that the classically conceived variable-density sound negative developer consisting of methyl *p*-aminophenol sulfate (Metol), hydroquinone, sodium sulfite, borax, boric acid, and sodium bromide may be, in the light of these works, simplified so that the resulting developer consists of Metol, sodium sulfite, borax, and sodium bromide.

DISCUSSION

The composition of the usual variable-density type sound developer used in machine processing, is such that the concentration of Metol and hydroquinone is of the order of 0.3 and 0.9 grams per liter, respectively. The developer functions at an average pH of 9.0, and stabilization with respect to pH is attempted by the use of boric acid as a buffering agent.

Reinders and Beuckers,¹ in their studies on the activity of photographic reducing agents as a function of the pH value, have shown

* Presented Oct. 18, 1943, at the Technical Conference in Hollywood.

** Columbia Pictures Corporation, Hollywood.

that at pH levels below 9.2, hydroquinone has so great an inertia value that its reduction potential relative to that of Metol is practically nil. Figs. 1 and 2 from their paper show density as a function of developing time under varying values of pH , the concentration of Metol and hydroquinone being held constant to 0.1 mol each. The hydroquinone curves, Fig. 1, show that at a pH of 9.2, despite a concentration of 11 grams per liter, the inertia value is such that the reduction of silver halide does not commence for almost 8 min and then proceeds at a reduced velocity rate. The authors extended this work on hydroquinone activity to approximate conditions of pH and hydroquinone concentration met with in variable-density sound negative developers.

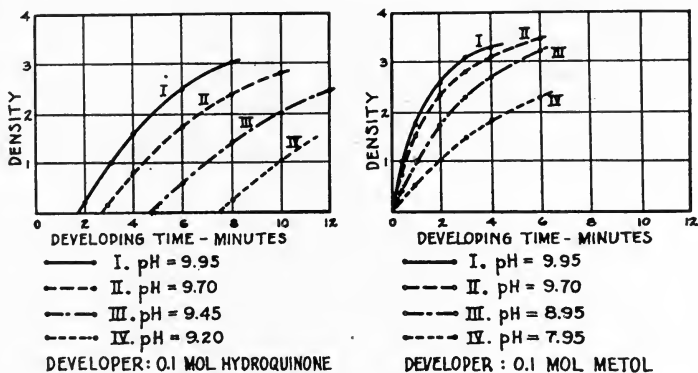

FIGS. 1 and 2. Metol and hydroquinone activity as a function of the hydroxyl ion concentration.

A developer was compounded with 0.0083 mol of hydroquinone (0.9 gram), 12 times less hydroquinone than the quantity used by Reinders and Beuckers, 0.5 mol anhydrous sodium sulfite, 0.002 mol of potassium bromide. The pH of this solution was adjusted to 9.0. Sensitometric strips on Eastman 1301 emulsion were made by exposure in an Eastman IIB sensitometer and were developed by hand agitation in this solution at 68 F. The strips were developed for periods of 12, 16, and 24 min. After 24 min of development the density of the eleventh step was 0.05.

It is apparent from the foregoing work that hydroquinone is functionless in concentrations and at pH values met with in variable-density sound negative processing developers.

The possibility that Metol and hydroquinone in solution may form a new developing compound, which has been suggested and named "Metaquinone," has been proved nonexistent by the work of Lehmann and Tausch.² They show that Metol and hydroquinone in solution exist only as a mixture and not in chemical combination. Yet experience in handling such solutions, in machine operation, has shown that the hydroquinone apparently manifests itself.

The work of Crabtree and Schwingel³ helps explain the anomaly wherein hydroquinone, incorporated in developers of low *pH* values, displays photographic activity. These authors showed that in developers compounded with Metol, hydroquinone, sodium sulfite, and borax, even though they were buffered with boric acid, continuous aeration of the developer resulted in a marked increase of gamma and density. In their work they found that an increase of gamma and density was associated with an increase of *pH* of the order of 0.60. They then showed that an unbuffered developer compounded with Metol, borax, and sodium sulfite showed no increase in *pH* on aeration. It was only when this developer was charged with colloidal silver that aeration resulted in some oxidation of the developing agent. It was assumed that the colloidal silver catalyzed the reaction.

It is apparent from this work that it is the oxidation of the hydroquinone and the products resulting from this oxidation which, despite the buffer agent, tend to increase the photographic activity of a Metol-hydroquinone-borax developer. The chemistry of this oxidation process is such that for each mol of hydroquinone oxidized to the monosulfonate state, a mol of sodium hydroxide is formed, as shown in the following equation:

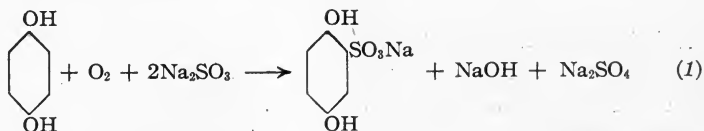

The hydroquinone monosulfonate formed is capable of being oxidized to the disulfonate condition with further liberation of caustic soda as follows:

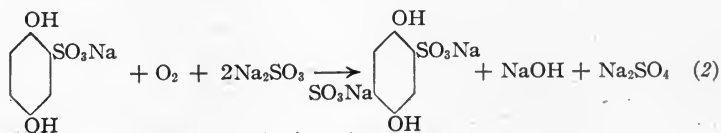

Lehmann and Tausch⁴ have shown that this second reaction occurs only when practically all of the hydroquinone has been oxidized to hydroquinone monosulfonate. From the standpoint of machine processing with accompanying batch or continuous replenishment, it can be assumed that only the reaction shown in Eq. (1) is of importance. Therefore, for every mol of hydroquinone oxidized a mol of caustic soda is formed. It is solely through this reaction that hydroquinone manifests itself in developers of low pH value because the liberated sodium hydroxide increases the developer pH which in turn results in an increase of the reduction potential of the Metol present.

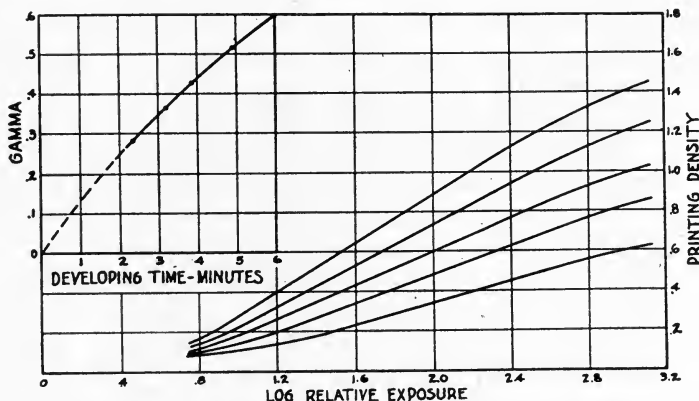

FIG. 3. Negative H and D curves for various developing times and time-gamma curve.

APPLICATION

It follows from the data presented that a variable-density sound negative developer can be compounded in which hydroquinone and boric acid may be advantageously eliminated. The ratio of Metol: bromide: sulfite: pH level in this new developer was so adjusted that the desired sensitometric characteristics were obtained. Fig. 3 represents the H and D and time-gamma characteristics of this developer using Eastman 1301 type emulsion exposed in an Eastman *Iib* sensitometer. Densities are negative printing densities⁵ as determined with the Electrical Research Products integrating sphere densitometer.

The developer is used in a continuous processing machine of conventional design. Care has been taken to design the circulatory

system so that aeration is held to a minimum. The developer is fed, at the rate of 40 gal per min, through a submerged spray system facing the line of film travel. The excess developer is carried away from the developing tanks by means of a submerged overflow system.

The developer strength is maintained by the batch system of replenishment based on footage processed per unit of time. The volume of replenisher entering the system per unit of time was arrived at by first determining the quantity of liquid to be discarded and replaced so that a constant bromide level could be maintained. Concurrently with this the Metol:borax:sulfite ratio of the replenisher was adjusted so that the developer remained in equilibrium regardless of the footage processed.

The developer is subject to daily chemical analysis. The typical analyses shown in Table 1 are indicative of the stability effected during a week's run in which time an average of 15,000 ft per day of Eastman 1301 type variable-density sound negative film is processed.

Day	1	2	3	4	5	6
Metol (grams per liter)	0.51	0.52	0.47	0.50	0.50	0.48
Sodium Bromide (grams per liter)	0.25	0.23	0.20	0.24	0.23	0.22
Anh. Sodium Sulfite (grams per liter)	57.2	57.5	57.3	57.2	57.2	57.4
pH	8.95	8.94	8.95	8.95	8.93	8.95

The method of analysis is that described by Atkinson and Shaner.⁶ The sodium bromide was rechecked potentiometrically and the pH was determined with a Beckman pH meter in which the precision of reproducibility is 0.02.

Table 2 represents the control H and D strips located at the start of the day's run, at which time the samples for chemical analysis were taken. Negative printing gammas and densities of the eleventh step of the sensitometric tablet were recorded.

Day	1	2	3	4	5	6
Negative Gamma	0.40	0.41	0.41	0.42	0.41	0.41
Control Density	0.45	0.45	0.45	0.47	0.46	0.47

SENSITOMETRY

Sensitometric determinations were made employing the Eastman *IIB* sensitometer and the Electrical Research Products integrating sphere densitometer.

Typical H and D curves for the Eastman 1301 stock are shown in Fig. 4 and are the composite of 5 different control strips chosen at random during development runs. Two curves are shown, one the result of plotting visual negative densities, and the other the result of plotting negative printing densities after the method described by Frayne.⁷ In comparing the 2 curves it will be observed that the visual H and D curve displays a lower break in the shoulder, whereas that obtained by plotting the printing densities displays a higher shoulder and consequent longer straight-line portion with a latitude of 1.75 on the log E axis.

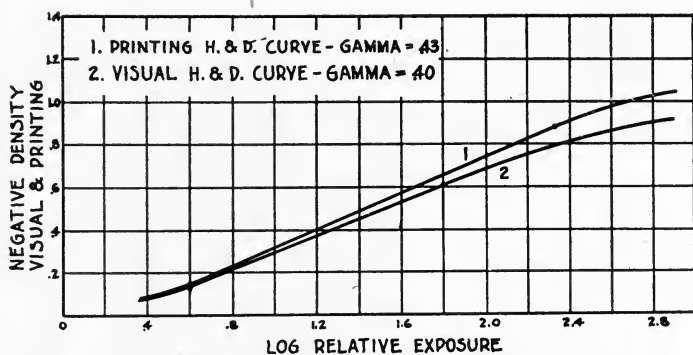

FIG. 4. Printing and visual H and D curves for Eastman 1301 sound negatives.

The printing qualities of the sensitometric negatives were examined in a group of prints which was printed darker than normal for the purpose of reflecting the linear printing characteristics of the negative in the region of the shoulder. Prints were made on Eastman 1302 stock with unfiltered tungsten as a light source. Fig. 5 illustrates the curve, a composite of 5 different control strips, resulting from plotting the visual print densities against the log relative exposures of the negative in such a manner as to display the usual over-all gamma characteristic. Examination of this curve shows that the long linear characteristic of the negative, which results from plotting printing densities and, in particular, that portion adjacent to the shoulder, is faithfully reflected in the print. It is evident, then, that the negative H and D curve, with its low breaking shoulder and restricted latitude which results from plotting visual densities, is

not representative of the printing qualities of the negative, and is of no value as a means of indicating the true negative characteristic.

From the foregoing it may be concluded that in this simple type of Metol variable-density sound negative developer, the required H and D characteristics are produced and are of such a nature that they are normally reflected in the print.

Again referring to Fig. 4, it will be observed that the negative

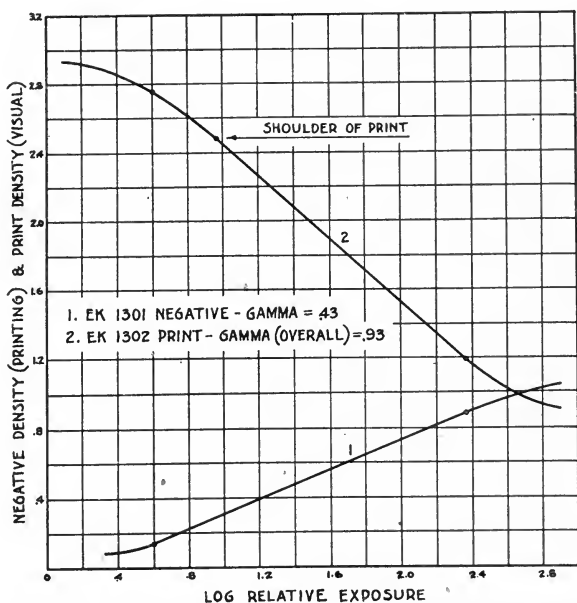

FIG. 5. Negative H and D curve and corresponding print curve using unfiltered tungsten light source.

printing and visual densities are closely related throughout the linear portions of the curves. Since these densities are obtained when the densitometer response is nominally peaked at 4300 and 5500 angstroms, respectively, it may be concluded that the Metol developer when used with the 1301 stock produces a silver image not far removed from a neutral value in its spectral transmission.

Fig. 6 illustrates the curve resulting from plotting the corresponding visual and printing densities of the negative sensitometric strips. The approximate equation for this curve is

$$D_p = 0.015 + 1.02D_v + 0.0021e^{4.10D_v} \quad (3)$$

in which D_p represents the printing density and D_v the visual density. Since this equation indicates a substantial departure from linearity in the relationship of printing to visual densities, comparison with similar observations made by Frayne⁸ on Eastman 1301 and other stocks indicates that the Metol developer is capable of producing fine grain and consequently should be particularly suitable when used in connection with variable-density sound negatives.

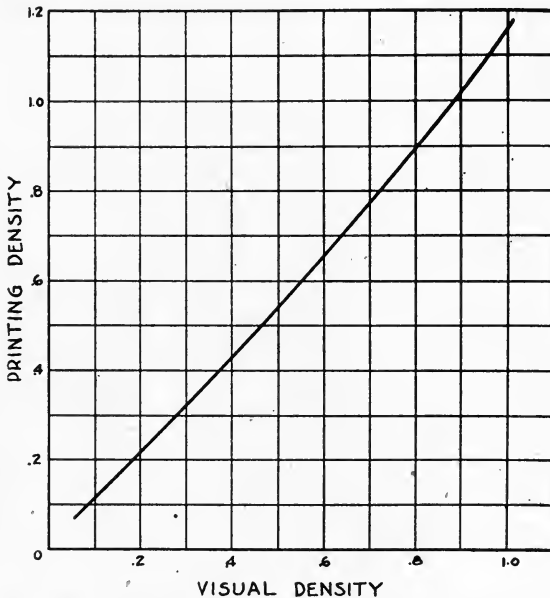

FIG. 6. Relation of printing to visual density for Eastman 1301 emulsion in Metol developer.

OPERATION

In practical operation over a period of time the Metol developer has shown satisfactory operational stability. Figures taken from the sensitometric control charts covering complete negative runs over a period of 6 days are shown in Table 3 and serve to indicate the amount of stability which can be expected from the use of the Metol developer with a properly adjusted replenisher system.

As has been previously indicated, approximately 15,000 ft of negative are processed per day. During these runs, the maximum variation in developing time required to maintain constant gamma is

shown in the table as 5 sec. The smaller time variations indicate better application of the rate of replenishment.

TABLE 3

Day	1	2	3	4	5	6
Maximum Variation:						
Developing Time (in Sec)	3	0	0	0	5	5
Density	0.01	0.01	0.01	0.01	0.00	0.02

Speed of the developer is virtually constant as evidenced by a maximum variation in the gamma-density relationship of 0.02. This figure was obtained by observation of the density of the eleventh step of the sensitometric tablet under conditions of constant gamma, and is the result of measurements on several control strips distributed throughout each day's run. The stability displayed in this relationship is of value when developing variable-density sound negatives and simplifies the problem of maintaining the negative densities at a constant and optimum value.

CONCLUSION

It has been shown that the use of hydroquinone in developers of low pH of the order of 9.0, as, for example, variable-density sound negative types, is superfluous. A developer compounded with Metol only as the reducing agent may be used in an unbuffered solution providing care is taken to maintain a minimum state of aeration and a well-balanced replenisher. The advantage of this system is primarily ease of operational control, inasmuch as variation in pH due to hydroquinone oxidation is eliminated. Secondly, there is some economy in that the use of hydroquinone and boric acid is eliminated.

The authors wish to thank Mr. V. C. Shaner of the Eastman Kodak Company for his aid in preparing this paper.

REFERENCES

- ¹ REINDERS AND BEUCKERS: "Bericht über den VIII Internationalen Kongress" (1931), p. 171.
- ² LEHMANN AND TAUSCH: "Photographische Korrespondenz," **71**, No. 2 (Feb., 1935), p. 17.
- ³ CRABTREE, J. I., AND SCHWINGEL, C. H.: "Effect of Aeration on the Photographic Properties of Developers," *J. Soc. Mot. Pict. Eng.*, **XXXIV** (Apr., 1940), p. 375.
- ⁴ LEHMANN AND TAUSCH: *Ibid.*

⁵ FRAYNE, J. G.: "The Measurement of Photographic Printing Density," *J. Soc. Mot. Pict. Eng.*, **XXXVI** (June, 1941), p. 622.

⁶ ATKINSON, R. B., AND SHANER, V. C.: "Chemical Analysis of Photographic Developers and Fixing Baths," *J. Soc. Mot. Pict. Eng.*, **XXXIV** (May, 1940), p. 485.

⁷ FRAYNE: *Ibid.*

⁸ FRAYNE: *Ibid.*

SOCIETY ANNOUNCEMENTS

ATLANTIC COAST SECTION MEETING

The use of motion picture film and production methods in television broadcasting was discussed by Mr. Wyllis Cooper of the National Broadcasting Company and Mr. Worthington C. Miner of the Columbia Broadcasting System at a meeting of the Atlantic Coast Section of the Society held on March 22d at the Hotel Pennsylvania. Mr. Cooper pointed out that a televised film can utilize all the wide variety of effects and technique developed in the motion picture industry over many years, some effects being impossible, or at present impractical, with a live pickup. He also stressed the advantage to the small isolated broadcasting station of a supply of high-quality program material in the form of films especially produced for television broadcasting.

Mr. Miner expressed the opinion that transmission from films made by usual Hollywood technique would be too costly for extensive use. He also held that transmission directly from live actors gives a sense of presence not occurring in transmission from a film. Mr. Miner has found that some effects are more practical in direct transmission than in films.

It was pointed out that the ideas expressed by each speaker were his own and did not necessarily represent the policy of either NBC or CBS. Lively discussion developed when members of the large audience raised questions dealing with the subject.

It is planned to publish the papers with discussion in an early issue of the JOURNAL.

MEMBERS OF THE SOCIETY
LOST IN THE SERVICE OF
THEIR COUNTRY

FRANKLIN C. GILBERT

ISRAEL H. TILLES

Now Being Distributed

THE TECHNIQUE OF MOTION PICTURE PRODUCTION

Covering current technical practices in motion picture production, presented as a Symposium at the 51st Semi-Annual Technical Conference of the SMPE in Hollywood, 1942. . . . Now published in book form.

150 Pages—41 Illustrations

Each section written by a specialist in the motion picture industry. . . Authentic information on various technical problems of motion picture production.

CONTENTS

I	Technology in the Art of Producing Motion Pictures.....	Leon S. Becker
II	Cinematography in the Hollywood Studios: Black and White Cinematography.....	John W. Boyle
	Putting Clouds into Exterior Scenes.....	Charles G. Clarke
	Technicolor Cinematography.....	Winton Hoch
III	Special Photographic Effects.....	Fred M. Sersen
IV	Re-Recording Sound Motion Pictures.....	L. T. Goldsmith
V	The Technique of Production Sound Recording..	Homer G. Tasker
VI	Prescoring and Scoring.....	Bernard B. Brown
VII	Illumination in Motion Picture Production.....	R. G. Linderman, C. W. Handley and A. Rodgers
VIII	The Paramount Transparency Process Projection Equipment.....	Farciot Edouart
IX	Motion Picture Laboratory Practices.....	James R. Wilkinson
X	The Cutting and Editing of Motion Pictures...	Frederick Y. Smith
XI	The Projection of Motion Pictures.....	Herbert A. Starke

THE TECHNIQUE OF MOTION PICTURE PRODUCTION is a useful and valuable reference for technicians, students, librarians, and others desiring technological data on the motion picture industry compiled in one volume.

Price \$3.50*

Published for the Society of Motion Picture Engineers by Interscience Publishers, Inc.,
215 Fourth Avenue, New York 3, N. Y.

* 20% discount to members in good standing if ordered through SMPE.
Orders must be accompanied by check or money order. Use form on other side.

**PREFACE TO
THE TECHNIQUE OF MOTION PICTURE PRODUCTION**

At the Spring 1942 Technical Conference of the Society of Motion Picture Engineers in Hollywood, California, a symposium was presented covering the current technical practices in the motion picture industry as applied to actual motion picture production. While information with regard to many of the subjects treated is scattered through the literature, no such complete descriptions of the various techniques involved had hitherto been assembled in such a logical, convenient, and highly educational sequence. The program was received with such acclaim by the audiences in attendance that the Board of Governors of the Society authorized the publication of these papers in book form, after their publication in the JOURNAL.

The papers of the symposium are presented in the general order of the steps taken in the production and presentation of motion pictures in the studios, laboratories, and theaters. Each section has been prepared by a man well fitted by his knowledge and experience in a particular field to give authentic information on the various problems arising in the manufacture of this great entertainment and educational medium.

It is the hope of the Society that this book will prove a useful and valuable guide to the general solution of the many problems which characterize the motion picture industry, in particular as these problems may be encountered in the post-war period of re-establishment and expansion throughout the world.

Order Form for The Technique of Motion Picture Production

Society of Motion Picture Engineers

Hotel Pennsylvania

New York 1, N. Y.

Date

Gentlemen:

Please send me THE TECHNIQUE OF MOTION PICTURE PRODUCTION.

Enclosed is check or money order for.....

Name:.....**No. Copies**.....

Address:.....

Member (\$2.80 per copy).*

Non-Member (\$3.50 per copy).*

* Add 1% Sales Tax if mailed to New York City address.

JOURNAL OF THE SOCIETY OF MOTION PICTURE ENGINEERS

Vol 42

JUNE, 1944

No. 6

CONTENTS

	PAGE
New Lightweight Recording Equipment Serves in the War Effort	A. R. DAVIS 327
The Flat Spiral Reel for Processing 50-Ft Lengths of Film	C. E. IVES AND C. J. KUNZ 349
Evolution of Scoring Facilities at Columbia Pictures	J. P. LIVADARY AND M. RETTINGER 361
Improvements in Disney Scoring Stage	C. O. SLYFIELD 367
Acoustic Considerations in the Construction of Vocal Studios	E. B. MOUNCE, C. PORTMAN AND M. RETTINGER 372
The Vocal Room and Pre-Scoring Operations at RKO Radio Pictures	E. B. MOUNCE, C. PORTMAN AND M. RETTINGER 375
New Scoring Stage Shell and Vocal Studio Design	L. L. RYDER 379
Current Literature	384
Society Announcements	385
Index of the JOURNAL, Vol 42 (January-June, 1944):	
Author Index	388
Classified Index	391

(The Society is not responsible for statements of authors.)

Contents of previous issues of the JOURNAL are indexed in the
Industrial Arts Index available in public libraries.

JOURNAL OF THE SOCIETY OF MOTION PICTURE ENGINEERS

HARRY SMITH, JR., EDITOR
ARTHUR C. DOWNES, *Chairman*
Board of Editors

JOHN I. CRABTREE ALFRED N. GOLDSMITH EDWARD W. KELLOGG
CLYDE R. KEITH ALAN M. GUNDELFINGER CHARLES W. HANDLEY

ARTHUR C. HARDY
Officers of the Society

**President:* HERBERT GRIFFIN,
133 E. Santa Anita Ave., Burbank, Calif.

**Past-President:* EMERY HUSE,
6706 Santa Monica Blvd., Hollywood, Calif.

**Executive Vice-President:* LOREN L. RYDER,
5451 Marathon St., Hollywood, Calif.

***Engineering Vice-President:* DONALD E. HYNDMAN,
350 Madison Ave., New York, N. Y.

**Editorial Vice-President:* ARTHUR C. DOWNES,
Box 6087, Cleveland, Ohio.

***Financial Vice-President:* ARTHUR S. DICKINSON,
28 W. 44th St., New York, N. Y.

**Convention Vice-President:* WILLIAM C. KUNZMANN,
Box 6087, Cleveland, Ohio.

**Secretary:* E. ALLAN WILLIFORD,
30 E. 42d St., New York, N. Y.

**Treasurer:* M. R. BOYER
350 Fifth Ave., New York, N. Y.

Governors

**FRANK E. CARLSON, Nela Park, Cleveland, Ohio.

*†CHARLES W. HANDLEY, 1960 W. 84th St., Los Angeles, Calif.

**EDWARD M. HONAN, 6601 Romaine St., Hollywood, Calif.

*†CLYDE R. KEITH, 195 Broadway, New York, N. Y.

**JOHN A. MAURER, 117 E. 24th St., New York, N. Y.

*HOLLIS W. MOYSE, 6656 Santa Monica Blvd., Hollywood, Calif.

*WILLIAM A. MUELLER, 4000 W. Olive Ave., Burbank, Calif.

*H. W. REMERSHIED, 716 N. La Brea St., Hollywood, Calif.

**EARL I. SPONABLE, 360 W. 54th St., New York, N. Y.

*JOSEPH H. SPRAY, 1277 E. 14th St., Brooklyn, N. Y.

*REEVE O. STROCK, 111 Eighth Ave., New York, N. Y.

**WALLACE V. WOLFE, 1016 N. Sycamore St., Hollywood, Calif.

*Term expires December 31, 1944.

**Term expires December 31, 1945.

†Chairman, Pacific Coast Section.

‡Chairman, Atlantic Coast Section.

Subscription to non-members, \$8.00 per annum; to members, \$5.00 per annum, included in their annual membership dues; single copies, \$1.00. A discount on subscription or single copies of 15 per cent is allowed to accredited agencies. Order from the Society of Motion Picture Engineers, Inc., Hotel Pennsylvania, New York 1, N. Y.

Published monthly at Easton, Pa., by the Society of Motion Picture Engineers, Inc.
Publication Office, 20th & Northampton Sts., Easton, Pa.

General and Editorial Office, Hotel Pennsylvania, New York 1, N. Y.

Entered as second-class matter January 15, 1930, at the Post Office at Easton, Pa., under the Act of March 3, 1879. Copyrighted, 1944, by the Society of Motion Picture Engineers, Inc.

JOURNAL OF THE SOCIETY OF MOTION PICTURE ENGINEERS

Vol 42

JUNE, 1944

No. 6

NEW LIGHTWEIGHT RECORDING EQUIPMENT SERVES IN THE WAR EFFORT*

AINSLIE R. DAVIS**

Summary.—This paper describes a new lightweight recording equipment designed for use in small studios or on location. Also described are 4 new power supplies designed especially for use with sound recording equipment.

When an American soldier goes into battle he is the best equipped and best trained fighting man of any nation in the world. It is important that he have the best guns, airplanes, ships, sound communications equipment, clothing and food, but perhaps even more important he must be properly and completely trained. To train our fighting men in the fine arts of an offensive war and self-preservation, our military leaders are taking full advantage of all forms of visual training aids. The most effective of these is the talking motion picture. The old adage "a picture is worth ten thousand words" is particularly true when it comes to training our soldiers.

Whether or not proficient instructors on various subjects are available, good training aids are invaluable. They conserve manpower, time, and valuable materials. It is reported their use reduces the training period by approximately 40 per cent.

Training films have 2 great advantages as training aids—motion and sound. Motion is especially desirable where teamwork, co-ordination or movements of parts are shown. The advantage of a narrator with a good voice is equally great as it impresses the soldier unconsciously with the importance and validity of what he is seeing. Actual battle pictures and training films are an ideal means of acquainting the soldier with what he may expect when he gets into combat. So-called orientation films give the recruit a better idea of what he is fighting for and what he is fighting against. The quality of

* Presented Oct. 22, 1943, at the Technical Conference in Hollywood.

** RCA Victor Division of Radio Corporation of America, Camden, N. J.

realism appeals to the imagination and emotions in such a way as to inspire a soldier to take full advantage of his training period and to give his best in battle. Not to be overlooked is the good work which is being done through motion pictures on the home front.

Working on the theory that one foot of film properly used is as effective as a bullet fired against the enemy, highly trained motion picture units are now turning out training films in ever-increasing quantities. Previous papers published in the JOURNAL have covered specific details of how these pictures are produced and the part they

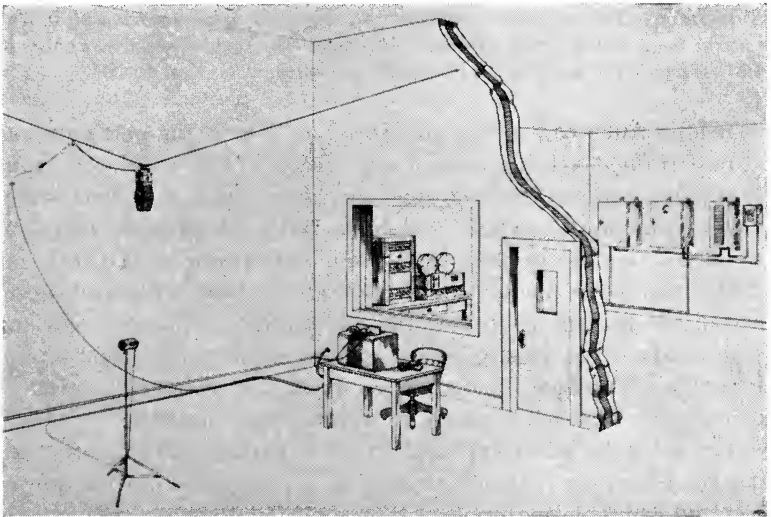

FIG. 1. Typical small 2-room studio setup for "dubbing" or narration.

are playing in the war effort, so I shall confine my remarks more to the equipment now available for the making of training films.

Sound recording equipments may be divided into 3 general classifications: The first is the single film system which permits the recording of sound on the same film used for the picture, by means of a highly developed compact optical system such as the RCA MI-3946 mounted on the back of the camera. These systems are currently being operated on Mitchell, Akeley and Wall cameras in every theater of this global war.

The second is the studio type of equipment such as may be found

in all the large studios. The third is a lightweight double film system suitable for work on location or in the studio.

PORTABLE DOUBLE FILM SYSTEM

Just before the outbreak of the war, RCA engineers were developing a new lightweight double film system which has since been identified as the *PM45* recording equipment. Now in production, this equipment is finding ready application in the production of war training films.

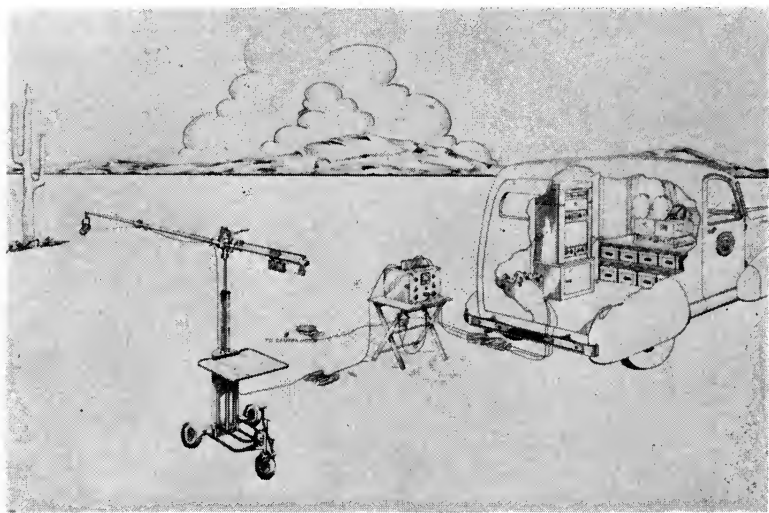

FIG. 2. *PM45* system mounted in a truck for work on location.

Basically the equipment consists of a 2-channel mixer amplifier, the main amplifier cabinet which includes a voltage amplifier, compressor, noise reduction amplifier, recording amplifier, high- and low-pass filters, and the film recorder.

Fig. 1 illustrates what might be considered a typical small 2-room studio arrangement using this recording equipment as a fixed channel. The microphones and the mixer amplifier are located on the sound stage, while the main amplifier and recording machine can be seen through the window between the rooms. On the wall of the recorder room can be seen the 3 items of power supply equipment recommended

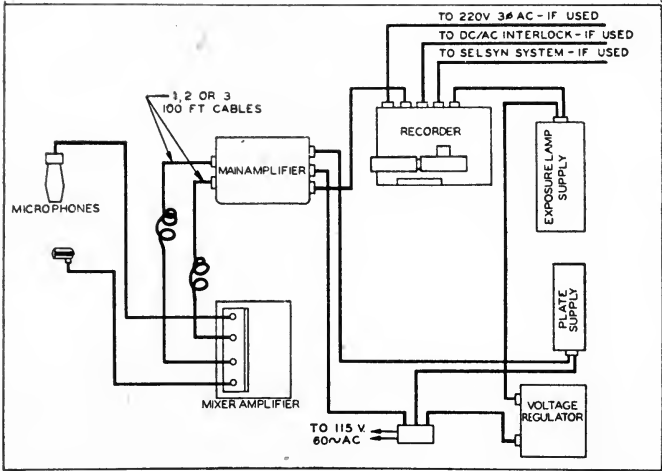

FIG. 3. Interunit connection diagram of system for studio operation.

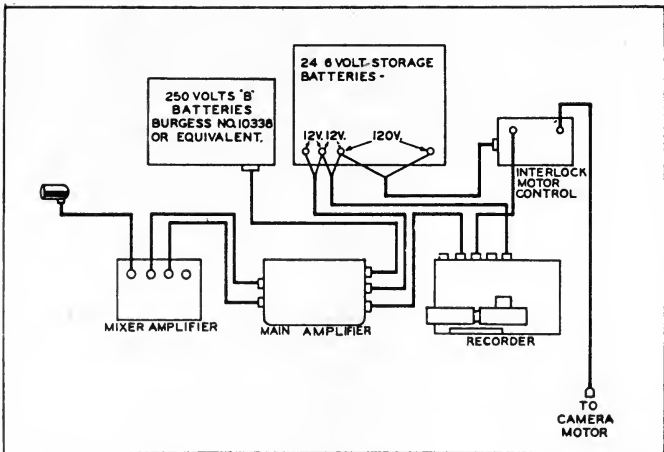

FIG. 4. Interunit connection diagram showing the equipment connected for interlock dc-ac operation.

for this channel when installed in a fixed location. They consist of a line voltage regulator, a low-voltage power supply to operate the recorder exposure lamp, and a regulated high-voltage unit for the amplifier plate supply. The tube filaments may be operated from alternating current if desired. Note the small amount of conduit needed in installing the equipment.

The over-all equipment design features portability, flexibility of operation, modern design, and performance closely approaching that of the larger, more elaborate systems. Five easily mounted motors are available for the recorder which permit operation of this equipment

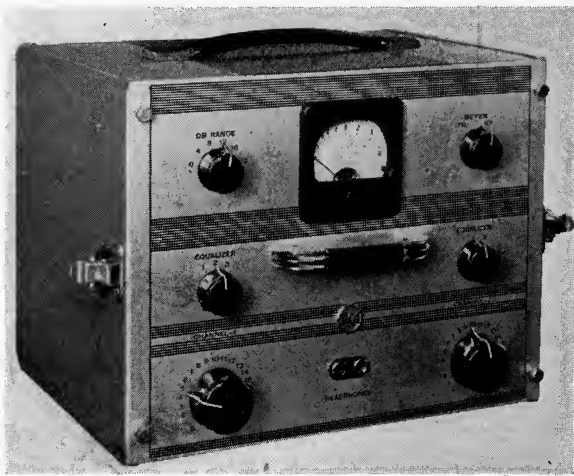

FIG. 5. Two-channel mixer amplifier, *MI-10216*.

from as many different sources of power. These are 50- or 60-cycle synchronous, 50- or 60-cycle Selsyn, and dc-ac interlock.

How the equipment may be mounted in a small truck is illustrated by Fig. 2. The use of dc-ac interlock motors will keep the motor supply requirements to a minimum, although other types of motors may be used if desired. Amplifier filaments and the recorder exposure lamp may be operated from storage batteries. The plate supply may be obtained from heavy duty *B* batteries, or from a dynamotor operated from storage batteries in the truck.

From the 2 illustrations one can readily visualize the flexibility of this recording equipment. All external connections are made by means of plugs, and by use of a switching arrangement the same ex-

ternal connectors are used whether the equipment is installed as a fixed channel or in a truck.

Figs. 3 and 4 illustrate in block diagram form how the equipment can be connected for studio and truck operation. Simplicity of operation has been the keynote in the design of this equipment.

MIXER AMPLIFIERS

The mixer amplifier shown in Fig. 5 has inputs for 2 microphones. Microphones either of the velocity, unidirectional, or pressure type may be used depending on the particular requirements. Taps on

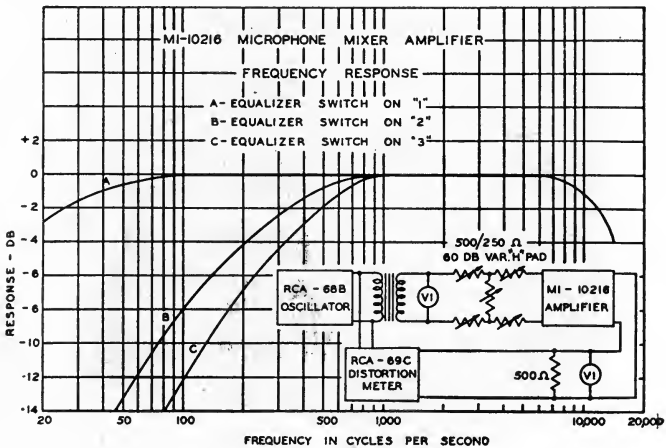

FIG. 6. Frequency response of *MI-10216* mixer amplifier.

the input transformers are provided in case it is desired to use microphones having an impedance of 30 ohms. The mixer controls follow the first stage of amplification, thereby providing the advantages of high level mixing. These controls are continuously variable carbon potentiometers. The transmission gain of each channel is 48 db, and the rated output is -10 db* with less than 1 per cent distortion from 100 to 5000 cps.

Visual monitoring is provided by means of the volume indicator meter mounted on the panel which reads the output of the amplifier system. The meter has a range from -10 to $+6$ db.* This range

* 0.006 w ref.

may be extended upward 20 db in 4 db steps by means of the *VI* switch at the left of the meter. This meter is also used to indicate heater voltage by turning the switch at the right marked *Fil-VI selector*.

Aural monitoring is accomplished by means of a pair of high-fidelity headphones which plug into jacks on the panel. Headphone volume can be adjusted by a potentiometer located on the mixer chassis.

The 3-position switch located in each channel of the mixer amplifier provides a choice of the response characteristics shown in Fig. 6. Curve *A* shows the characteristics used for recording music and many

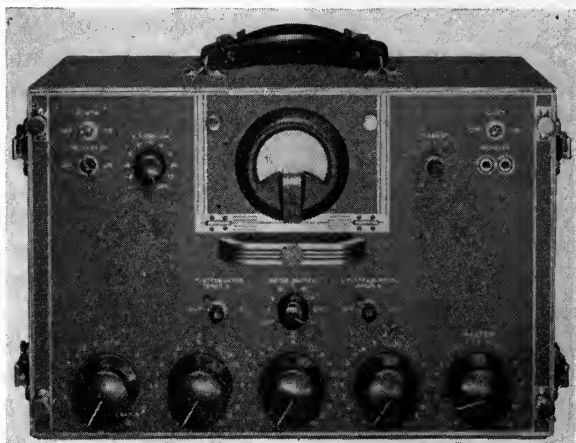

FIG. 7. Four-channel mixer amplifier, *MI-10202B*.

types of sound effects. Curves *B* and *C* represent 2 amounts of dialogue equalization that should meet most recording requirements.

The meter and controls are protected during transportation by a detachable cover. A zipper bag which completely covers the case, except the handle, is also available. The input and output connectors are accessible through a small door in the back of the case. The chassis may be removed from the case for servicing simply by loosening 4 thumbscrews.

For those whose recording activities require the mixing of additional sources of sound, a 4-channel mixer amplifier was designed which can be used interchangeably with the 2-channel mixer described above. (See Fig. 7.) This unit is a 3-stage voltage amplifier with four 250-ohm input channels and a single 500-ohm output. The normal fre-

quency response is essentially flat from 30 to 10,000 cycles. Channels 2 and 3 have low-frequency attenuation for dialogue recording which may be switched in or out of the circuits by means of switches located on the panel.

Variable ladder-type attenuators are used in the input of each channel and in addition, a master gain control is located between the first and second stages. A continuous check on the output of the recording amplifier is provided by a volume indicator meter on the mixer panel. The meter is also used to check heater voltage, plate voltage, and the plate current of each stage. Jacks for high-fidelity monitoring headphones are located on the panel. An *Oscillator* on-off switch converts the first amplifier stage to a 400-cycle oscillator for testing purposes.

The gain is 48 db and the maximum power output is -8 db* with less than 1 per cent harmonic distortion from 100 to 5000 cps.

The heater supply can be either a-c or d-c, 6 to 6.5 v. The plate requirement is 8.5 ma at 250 v.



FIG. 8. Amplifier, MI-10219.

MAIN AMPLIFIER

The mixer amplifier is connected to the main amplifier cabinet by 2 cables, one carrying low level audio and plate voltage, and the other carrying the monitor line and filament supply. Up to 300 ft of cable can be used between the 2 units.

The main amplifier cabinet (see Fig. 8) includes a power distribution

* 0.006 w. ref.

panel, a combined voltage and compressor amplifier, a combined power and noise reduction amplifier, the necessary high- and low-pass filters, and film loss equalization. One of the features of this unit is the ease with which all of the component parts can be reached for servicing. The first step is to remove the front cover, which is constructed in one piece, thus exposing the amplifier units as shown in Fig. 9. This allows access to the tubes, external connections to the chassis, and cable connectors. The underside of each chassis is accessible by tilting it forward as illustrated in Fig. 10.

The cabinet may be placed on a table or shelf, or mounted on a wall. Input connections are made on the left of the cabinet while the output and power connections are made on the right side. A movable disk is located back of each amplifier control for the purpose of indicating normal settings.

The main gain and compressor amplifier is located at the bottom of the cabinet. This is a 3-stage amplifier with an 80-cycle high-pass filter ahead of the first stage. The first stage employs a pair of variable gain tubes in a push-pull circuit. A step gain control is used at the head end of the amplifier. The oscillator is included on the same chassis to provide a 400-cycle signal source. The oscillator level may be varied by means of the *Osc. Level* control on the panel. The output of the oscillator is used for balancing the variable gain tubes, setting levels, and checking the channel. Film loss compensation for 35- or 16-mm recording is provided by a 3-position switch. (See Fig. 11.) A flat response is obtained by turning the knob to mid position. Fig. 11 also illustrates the effect of the 80-cycle high-pass filter located just ahead of the first stage. The

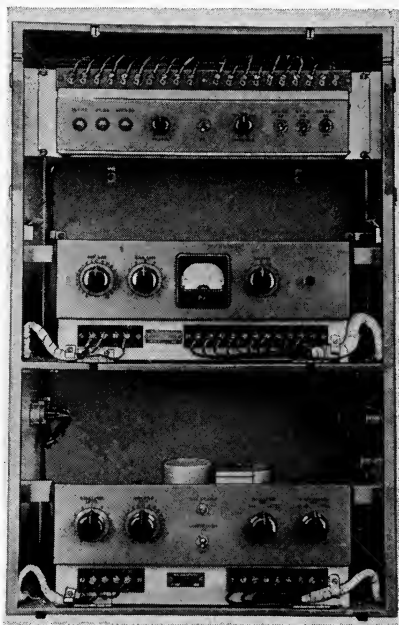

FIG. 9. Amplifier with front cover removed.

amplifier has a gain of 44 db without compression and a rated output of +6 db.*

A normal compression characteristic is shown by Fig. 12. The straight line represents the normal characteristic of the amplifier while the other shows the action of the compressor. It will be observed that the 2 curves separate at -4 db. Control of the compression characteristic can be accomplished without changing the amplifier simply by varying the input gain control of the compressor amplifier and the

gain control of the recording amplifier. If greater compression is desired, the gain control of the compressor is advanced and the gain of the following amplifier reduced. A compression characteristic of 20 into 10 db is recommended, but this can be altered to suit all requirements.

The recording and ground noise reduction amplifier is located near the middle of the cabinet. This unit consists of a 2-stage power amplifier using a 6J7 and a 6L6. The first stage is preceded by a 6000-cycle low-pass filter. (Other filters having a higher cutoff may be substituted.) Control of gain is accomplished by a step potentiometer before the first stage.

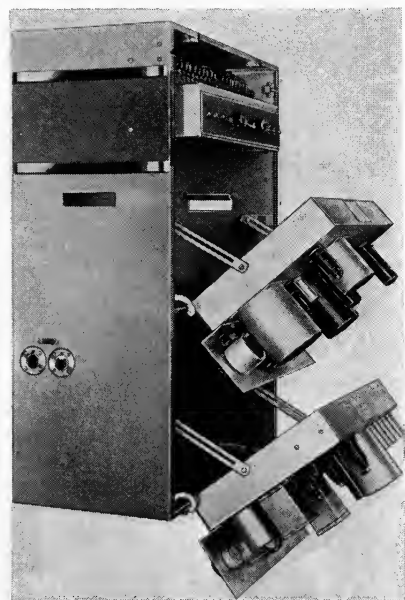

FIG. 10. Amplifier with chassis tilted forward for servicing.

The transmission gain of the amplifier is 40 db and the rated output is +20 db with less than 1 per cent distortion from 100 to 5000 cps. The frequency response is shown in Fig. 13. Also included on the same chassis is a single stage amplifier, the output of which is rectified and used to control the grid bias of a 6L6. This tube controls the current in the shutter circuit of the noise reduction system. The maximum output of this circuit is 40 ma d-c.

A carbon potentiometer controls the input to the noise reduction

* 0.006 w ref.

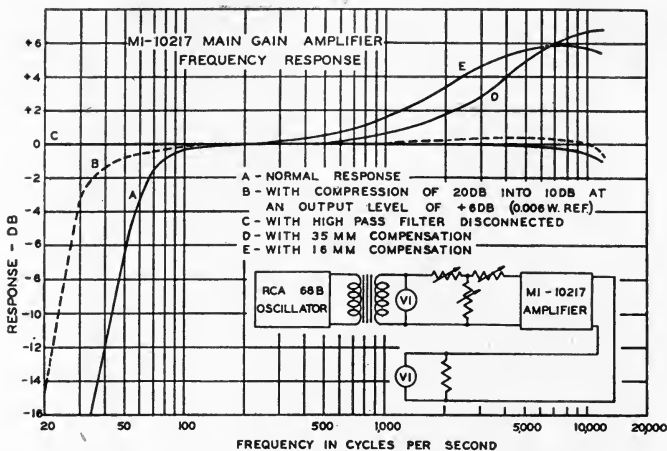

FIG. 11. Frequency response of the main gain amplifier.

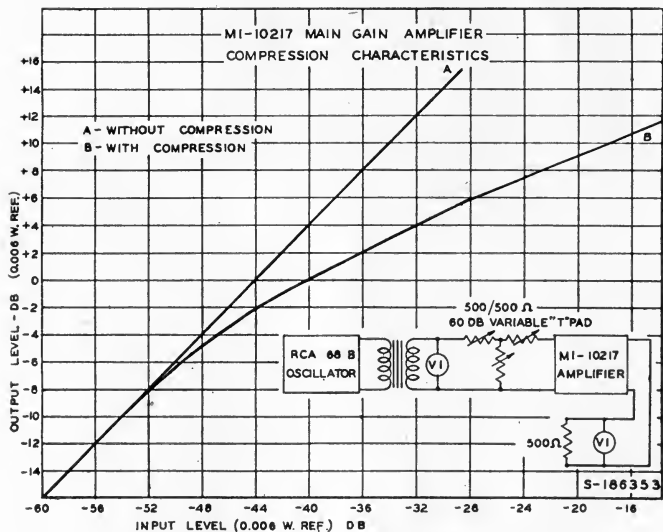

FIG. 12. Compression characteristics of the main gain amplifier.

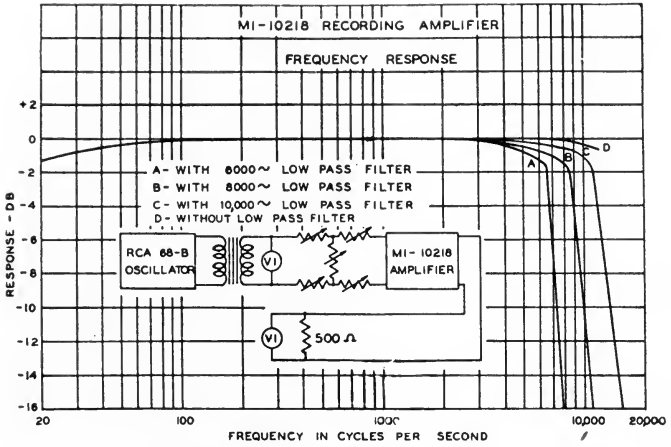

FIG. 13. Frequency response of the recording amplifier.

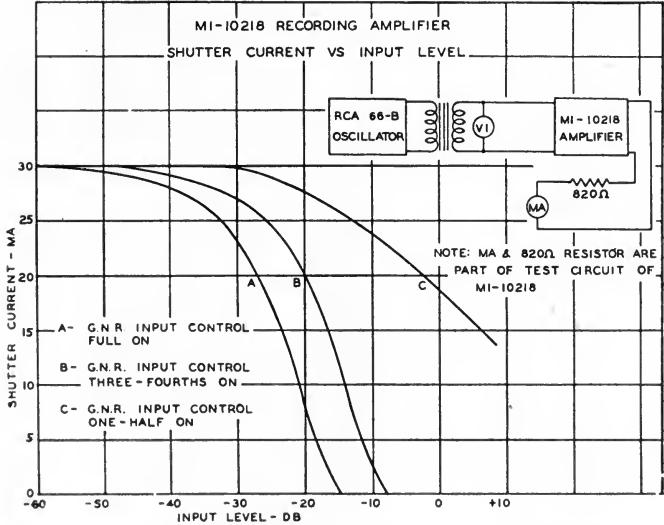

FIG. 14. Recording amplifier shutter current vs. input level.

amplifier and a 2000-ohm linear wire-wound potentiometer sets the initial shutter current. A 0-50 d-c milliammeter is provided to read shutter current. Fig. 14 shows the shutter current *vs.* input level.

The main gain and recording amplifiers will operate from either an a-c or d-c heater supply. The combined *A* supply requirement is 4.8 amp at 6.3 v, and the total plate supply is 87 ma at 250 v.

The power control panel is mounted at the top of the cabinet. This panel includes controls for adjusting the heater voltage supplied to all

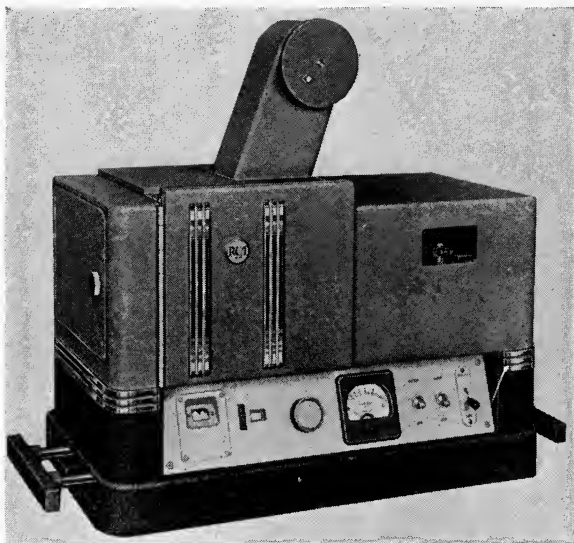

FIG. 15. The MI-10304 recorder.

3 amplifiers, a switch for selecting either an a-c or d-c heater supply, control switches for 115 v a-c, 8 v d-c, and 250 v d-c, and terminals for connection of the various power sources, and distribution of heater and plate power to the respective amplifiers.

The complete unit is finished in 2 tones of gray wrinkle. Slots provided in each side of the cabinet serve as handles.

RECORDER

The recorder was designed as a rugged semiportable machine and is enclosed in an attractively styled case. In Fig. 15 the magazine has been removed to show the enclosed type of positive take-up drive. The handles are shown in the extended position. When not needed,

they slide in so as to be flush with the sides of the recorder. A compartment on the left end of the recorder provides convenient storage space for the focusing microscope, spare exposure lamps, and several small tools. The optical system is located on the right side of the recorder, and the monitoring card is viewed through the rectangular

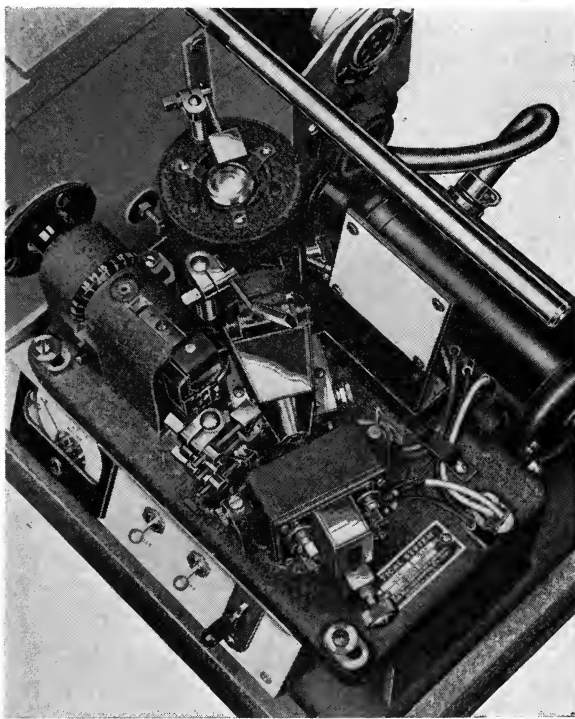

FIG. 16. Recording optical system.

opening that can be seen in the optical system cover. The door on the left side provides access to the film compartment. In the base casting are located the necessary controls for operation of the recorder, including (from left to right) a tachometer, footage counter, lamp rheostat, lamp current meter with an extended scale, motor switch, lamp switch, and audio switch. It will be observed that the panel slopes back so that the controls can be seen easily from either a seated or standing position.

Another feature of the recorder which may be of considerable interest is that it is designed so that it can be converted very readily to use

16-mm film either at a speed of 90 ft per min, or at a more conventional film speed for 16-mm of 36 ft per min.

Fig. 16 shows a top view of the optical system with the cover removed. Those who are familiar with RCA recording optical systems will recognize in this one of the usual arrangements of components. Normally this system is furnished with a duplex shutter for ground noise reduction, but intermediate lens barrels are available for the recording of Class A, Class AB, and Class B push-pull sound tracks.

The light beam is modulated by a galvanometer. Visual monitoring is provided by projecting a portion of the modulated light beam on the white screen. The image of the exposure lamp filament is also projected on the screen. The UV filter is mounted in the lens barrel just behind the slit. The film path, shown by Fig. 17, is very simple and easy to thread. Ample hand room is provided in the film compartment. Uniform motion at the recording point is accomplished by means of a film pulled drum to which is mounted a rotary stabilizer.

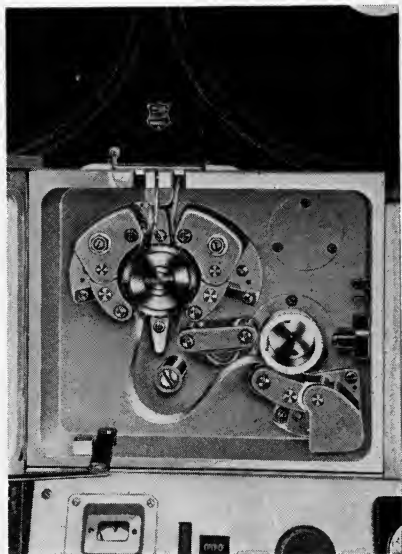

FIG. 17. Recorder film compartment.

Fig. 18 shows the back of the recorder with the back plates removed to show the interior of the gear box with the rotary stabilizer and the take-up housing. Power and audio connections are made through the plugs and receptacles in the base. The mounting arrangement of the interchangeable motors is shown on the left. A portion of the motor weight is borne by a sprung cradle which may be seen under the motor. This also serves to minimize vibration.

NEW POWER SUPPLY UNITS

Recent additions to the RCA line of sound recording equipment include 4 new power supply units.

Regulated Plate Supply.—This unit, shown in Figs. 19 and 20, was designed to furnish a regulated plate supply voltage of 250 v to a number of amplifiers drawing up to 300 ma. It consists of two 866A rectifier tubes, a filter, and regulator. The regulator employs an RCA 6J7 control tube with a 991 tube in its cathode circuit to maintain the cathode at a constant voltage. Six 1622 Radiotrons are con-

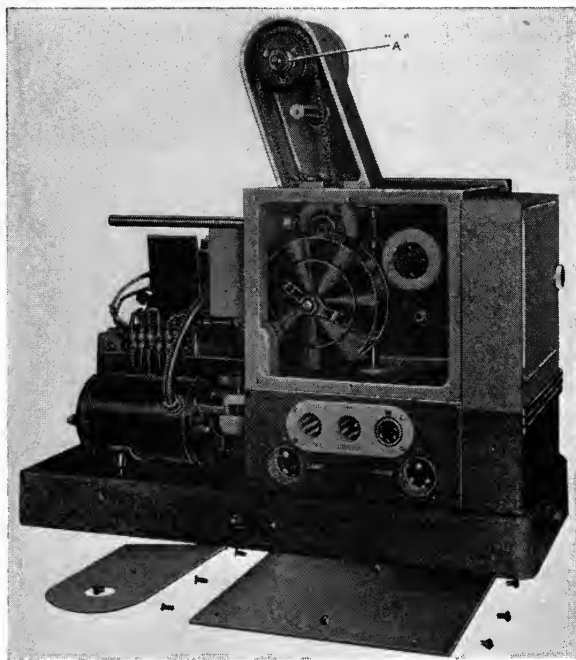

FIG. 18. Rear view of recorder showing chain drive take-up, rotary stabilizer, plugs for external connections and motor.

nected in parallel for regulating the voltage. Component parts are located so as to be easily accessible. This is illustrated in Fig. 20 which shows the regulator chassis tilted forward to provide for servicing. The cover plate is also hinged forward to expose the connections to the power transformer, reactors, and capacitors. The opening in the door permits viewing the meter which in addition to reading the d-c output voltage may also, by means of a switch, be used to check the current flowing through each of the 1622's.

The unit is designed to operate from 100 to 130, or 205 to 235 v, either 50 or 60 cycles. Major adjustments for line voltage initially are taken care of by 6 taps on the power transformer. The output voltage remains constant with current loads from 125 to 300 ma (see Fig. 21). A comparison of load voltage and line voltage is shown by the curve in Fig. 22. It will be observed that although the line voltage varies from 100 to 130 v, the output voltage remains within plus or minus 1 v. These readings were taken with the line connected to the 115-v tap. For normal line variations, using the appropriate tap on the power transformer primary, variations in output voltage remain within plus or minus $\frac{1}{5}$ v. The output hum level is 120 db below 250 v, or 0.00025 v at a load of 300 ma using a 60-cycle supply.

The unit was designed for wall mounting and has the following physical specifications: width $18\frac{1}{2}$ in., depth $10\frac{1}{2}$ in., height $21\frac{1}{4}$ in., and weight $110\frac{1}{2}$ lb.

Low-Voltage Power Supply.

—The low-voltage power supply is shown in Fig. 23. This unit was designed for use in sound recording channels to provide d-c for amplifier heaters, exposure lamps, exciter lamps, *etc.* When used for the exposure lamp it is usually preceded by a voltage regulator to insure uniform exposure of the film.

The principal feature of this unit is that it employs 8 full wave copper oxide rectifier units connected in parallel, insuring long life and dependable service with practically no maintenance. In addition to the copper oxide rectifiers the assembly includes a power transformer, a 2-section choke, input filter, and a bleeder resistor.

It is designed to operate on 100 to 130 v, or 205 to 235 v, 50 or 60 cycles. Its rated output is 14 v at 11 amp. The ripple voltage is 0.003 v (74 db below 15 v).

Fig. 24 shows the d-c load voltage *vs.* load current characteristics.



FIG. 19. Regulated plate supply, MI-10501.



FIG. 20. Plate supply with units exposed for servicing.

MI-1050I REGULATED "B" SUPPLY
 OUTPUT VOLTAGE VS LOAD
 LINE VOLTAGE - 115V (60 CY) ON 115V TAP
 LOAD RIPPLE - 126DB BELOW 250V DC

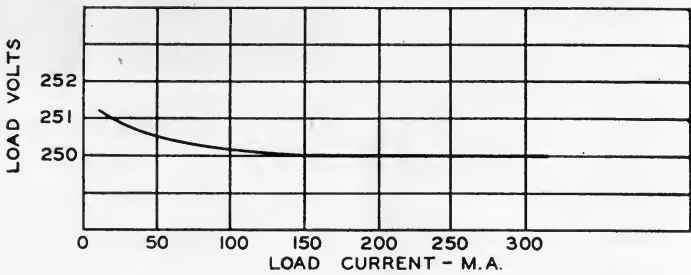

FIG. 21.

MI-1050I REGULATED "B" SUPPLY
 LOAD VOLTAGE VS LINE VOLTAGE

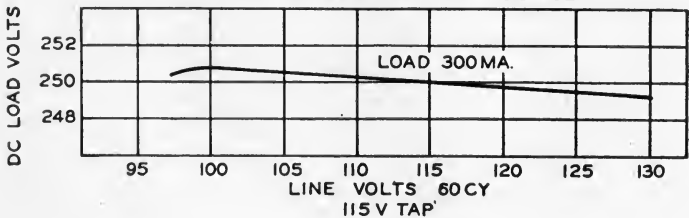

FIG. 22.

The secondary of the power transformer has taps for 24, 29, and 34 v to provide voltage adjustments when required.



FIG. 23. Low-voltage power supply, *MI-10505*.

MI-10505 "A" SUPPLY
OUTPUT VOLTAGE VS LOAD CURRENT

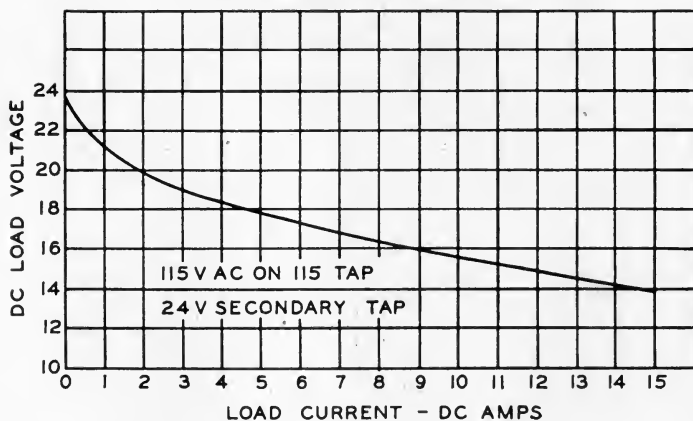

FIG. 24.

The cabinet, designed for wall mounting, is $23\frac{1}{2}$ in. high, $17\frac{5}{8}$ in. wide, $12\frac{5}{8}$ in. deep, and weighs 162 lb.

Medium Duty Plate Supply.—A regulated plate supply is shown in Fig. 25 which delivers up to 90 ma at 170 to 280 v. In addition the power transformer has an auxiliary winding to provide 7 v

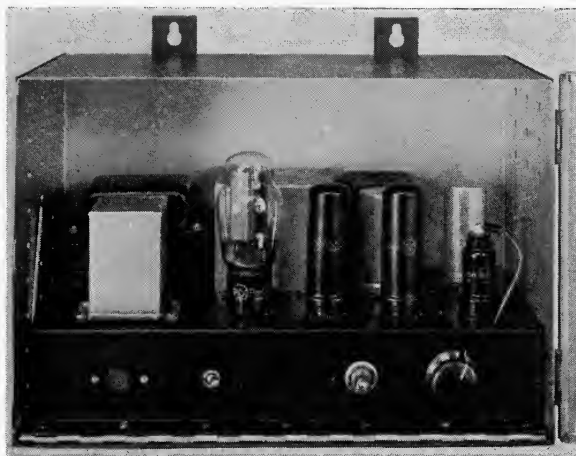

FIG. 25. Regulated plate supply, *MI-10504*.

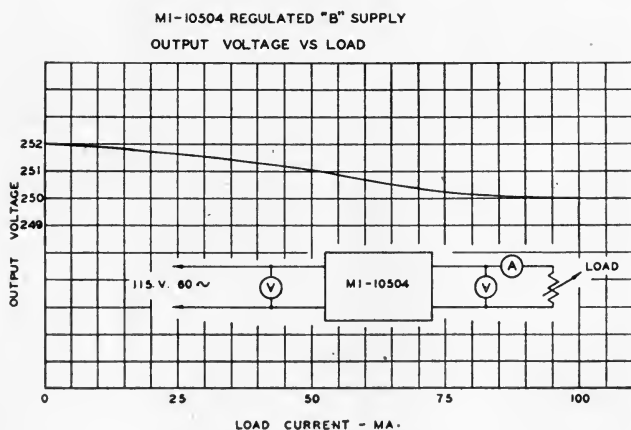

FIG. 26.

a-c, at 3.6 amp to an external circuit. It will operate from 100 to 130, or 205 to 235 v, 50 or 60 cycles. The mounting brackets provided with the unit permit it to be mounted in a standard relay rack or on a wall.

The chassis is hinged at the front so that it can be swung out of the case for servicing.

Performance of the power unit is shown by Figs. 26 and 27. Fig. 26 shows the output voltage *vs.* load; Fig. 27 shows the output voltage for line voltages of 100 to 130 v, using the 115-v tap on the transformer primary.

Portable B Supply.—Another recent addition is a portable power supply unit, Fig. 28, designed primarily for lightweight

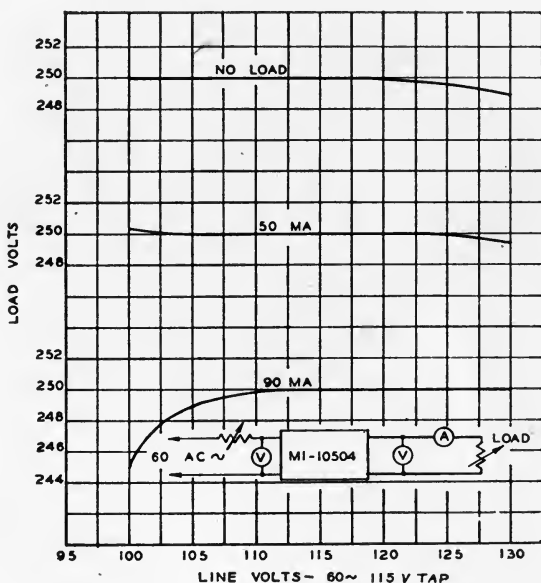

FIG. 27. The output voltage for line voltages of 100 to 130 v, using the 115-v tap.

portable sound recording channels where a medium power, well-regulated, *B* supply is required. It employs a vibrator and has 2 voltage regulator tubes in series across the output. It weighs approximately 15 lb including metal case, and operates from an 8-v storage battery. Its output is rated at 180 v, 30 ma. The output hum level is 0.003 v at 180 v, 18 ma output. The complete unit is contained in an acoustically padded, portable carrying case 12 in. long, 6½ in. wide, and 8½ in. high with Cannon plugs for input and output connections. This unit eliminates the need of dry batteries and makes it possible to operate portable recording equipment en-

tirely from storage batteries. This feature is particularly advantageous when operating in a remote location where a dependable supply of fresh *B* batteries is not always available.



FIG. 28. Portable *B* power supply unit.

CONCLUSION

From the foregoing description you will note that this equipment is basically similar to many other double film equipments already in service. In designing it the following considerations were kept in mind:

- (1) The performance of the equipment should closely approach that of the larger, more elaborate systems.
- (2) The component parts should be made readily accessible.
- (3) The expense of installation should be kept to a minimum.
- (4) The equipment should be suitable for either truck or fixed channel operation, and convenient for transportation by means of any of the common carriers.
- (5) The equipment should be attractively styled.

THE FLAT SPIRAL REEL FOR PROCESSING 50-FT LENGTHS OF FILM*

C. E. IVES AND C. J. KUNZ**

Summary.—The flat spiral reel employed for 6-ft lengths of still camera film is one of the most compact types of processing equipment. After preliminary chemical and physical treatment of the loaded reel it is possible to dry the film on the processing reel, thus diminishing the risk of damage in handling.

Complete processing units in 30-ft and 50-ft sizes have been built of stainless steel wire welded to flat radials. Other sizes are possible within limits which are discussed. The 2 mated sides were mounted on a reinforced bakelite hub which provides the bearing for rotation of the reel and terminates in a handle at one side. The stainless steel spirals were built by Nikor Products Co.

Accessory equipment consists of a rewind for loading and unloading the reel, processing and washing tanks, loose water stripper, and drying cabinet.

The intensity of agitation which can be given is limited. Consequently, while the uniformity of development is satisfactory for still photographs, it is not suitable for the most exacting motion picture work, although it may have some application in small-scale motion picture work.

In various branches of photography other than that of professional motion picture work, strips of film must often be processed which are too long for still photography methods and equipment. This material would not be processed on existing large continuous machines because of odd film width, the need for immediate results, unusual requirements as to chemical baths, or the required degree or time of treatment. In many cases, however, the quality of results must be equal in one or more respects to that provided only by the most modern large processing machines.

Generally speaking, the use of a small continuous machine would involve complications in respect to management and maintenance which would be intolerable in small-scale operations. Batch equipment¹ is indicated but existing designs are unsuitable because of chemical and mechanical shortcomings and the danger of physical damage to film which is always present when wet film is touched by the hands.

* Presented Oct. 18, 1943, at the Technical Conference in Hollywood.

** Kodak Research Laboratories, Rochester, N. Y.; Communication 955.

Requirements.—The equipment to be described was designed to meet the following requirements:

- (1). Complete protection of the film against scratching and gouging.
- (2) Assurance that the film will not be stretched or distorted.
- (3) Highly reproducible performance.
- (4) Simplicity of chemical supply and management.
- (5) Simplicity in operation so that no degree of expertness on the part of the user is necessary.

In order to satisfy requirements (1), (3), and (5), the handling of film must be entirely automatic or, at most, involve no more complicated techniques than rewinding and the moving of a film carrier from one solution to another. The manual operations of wiping off loose water, guiding the film through a squeegee, or loosening and arranging it on a drying reel could not be allowed therefore.

Available Methods and Equipment.—A simple system of chemical management capable of yielding reproducible results, as required under (3) and (4), would be provided by the use of prepared package chemicals and the replacement of baths after only a few runs following a prescribed program. Under this plan a compact arrangement of the film would make for economy of labor and chemicals.

Existing types of batch-handling equipment for the lengths in question which were sufficiently compact did not provide full assurance of successful mechanical treatment. The flat spiral arrangement used in the Stineman equipment,* or the various spiral reels for 5- or 6-ft lengths of still camera film, was capable of giving sufficiently uniform development for some types of work and was considered to be of possible use if provision could be made for drying. Methods by which the wet film could be transferred with safety from the processing reel to a drying unit would involve complicated equipment and did not appear promising. The problem of control of tension during drying would remain in any case.

The Spiral Reel.—Experiments with the small spiral reel of the Kodak adjustable film tank outfit demonstrated the possibility of removing sufficient water by centrifugal force to permit drying on the reel. The experimental method consisted in swinging the reel vigorously at arm's length. This method of removing water was appli-

* Manufactured by R. P. Stineman, Los Angeles, Calif.

cable, of course, only to those types of reels which enclosed the film securely while making contact with it only on very small areas. Drying was brought about by drawing air through the reel in a direction parallel to the axis.

Since this 6-ft spiral reel equipment appeared to satisfy all of the requirements mentioned, the design of larger reels and auxiliary equipment was undertaken. Complete equipment would include:

- (1) A reel of 25 ft or more capacity suitable for the type of work intended.
- (2) A rewind reel for loading and unloading.
- (3) Tanks of suitable design for processing with such a reel.
- (4) A means of washing.
- (5) A means of removing loose water by mechanical treatment of the loaded reel.
- (6) A drier.

Methods of Construction.—Three types of reel construction were considered for making the spiral reel tracks, as follows: (1) molding, (2) cutting the spiral form in the face of a piece of plastic sheet, and (3) welding a metal wire to a frame. Experience had shown that machine cutting would be slow and costly and that molding would require a large outlay for tools before anything could be done on various other phases of the problem. The brittleness of molded materials would require thick sections and closely spaced radial members, neither of which were desirable.

At this point it was found that Mr. Hinsdale Smith, Jr., of the Nikor Products Company was prepared to undertake the making of experimental, large-size spiral tracks of welded stainless steel somewhat similar in construction to the small reels marketed by that company for amateur still photography. This type of construction provided more open space than the others for access of the treating solutions and the drying air at the edges of the film. The choice of steel, of course, disposed of the question of brittleness and promised sufficient ruggedness.

The Stainless Steel Reels.—Experimental 30- and 50-ft 18-8 chromium nickel stainless steel reels were then made up with the round wire spiral track welded to 12 radial strips about $\frac{1}{16} \times \frac{3}{8}$ in. in section. The center is made to fit a core 3 in. in diameter to which the radials, prolonged inwardly, are bolted. The wire is $\frac{3}{32}$ in. in diameter and is spaced to give a $\frac{1}{7}$ -in. pitch. The film in a loaded reel

is positioned laterally by the radials, the inner surfaces of which are flush with the outer surface of the wire track. The thickness of that portion of the hub against which the radials are held, therefore, determines the width of the film track, in the present instance for 35-mm film, $1^{25}/64$ in. The 50-ft reel is illustrated in Fig. 1.

A handle is formed by an upward extension of the hub and a bearing for rotation of the reel by drilling a hole in the center. The bearing engages posts on the rewind and in the tanks on which it is desired to rotate the reel.

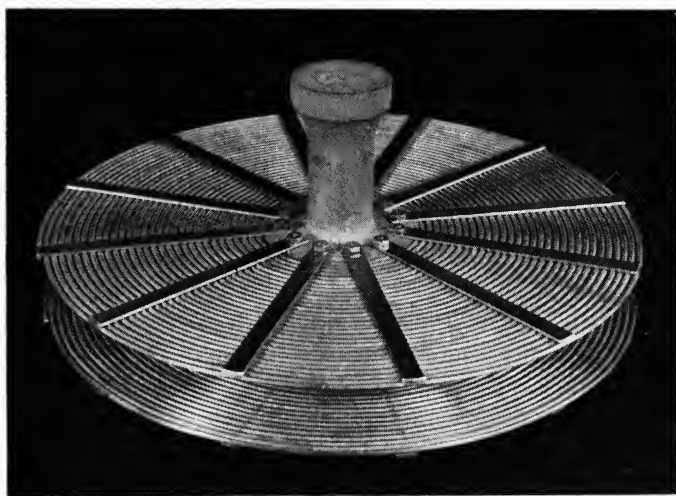

FIG. 1. The 50-ft flat spiral stainless steel reel.

Loading the Reel.—Only a short length of film can be made to enter a spiral reel by sliding it along the spiral track from the outer end, but no such limit has been met when the film is attached at the core of the reel and then, while arched on its longitudinal axis, wound in by rotation of the reel. In order to have the film pass the idle outer convolutions of the track without interference and enter at the proper point, it is desirable that the arched form be maintained by a guide which is always at a distance of about $2\frac{1}{2}$ in. from that point. A guide which operates satisfactorily is formed from No. 26 gauge stainless steel sheet by bending the edges back to form 70-degree angles at the sides of a $1\frac{1}{32}$ -in. wide channel for the film.

As shown in the photograph of the rewind (Fig. 2), this guide is attached by a nonkinking chain to an arm which permits it to follow the changing film path while holding it at the correct distance from the point where the film engages the track. The rewinding unit also includes the supply roll spindle, intended in the case illustrated to accommodate a camera spool, a punch for making a circular hole near the end of the film strip, and the cranks for the reel and the spool.

Processing Tanks.—The processing tanks shown in the center and at the left in Fig. 3 are made from No. 18 gauge stainless steel by

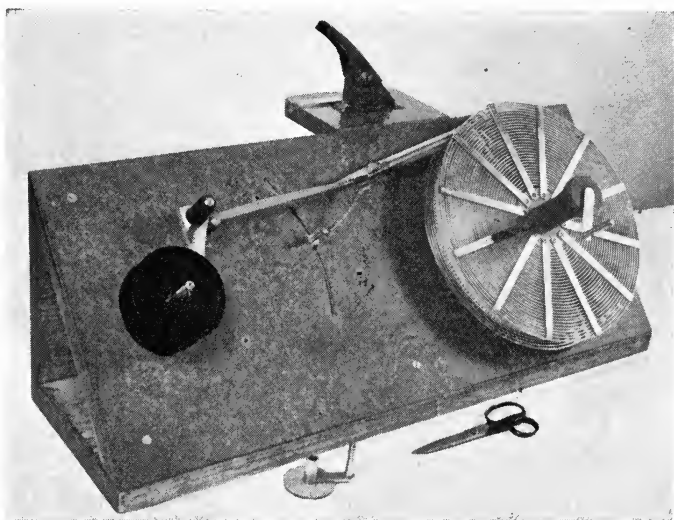

FIG. 2. The rewind for loading and unloading.

welding. The reel guide post is screwed into a disk of stainless steel welded to the bottom of the tank. This disk makes contact with the reinforced bakelite reel hub so that the spiral track is held clear of the tank bottom. The tanks are about $\frac{3}{4}$ in. larger in diameter than the reels and are $4\frac{1}{2}$ in. deep. As the rack enters the tank, it is guided into place by engagement first with the flared upper wall and then with the center post which is about $1\frac{1}{4}$ in. shorter. Later, the rack is guided by the center post as it is raised and rotated for the purpose of agitating the solution.

The washing tank is shown at the right in Fig. 3. No guide post is necessary since agitation is provided by motion of the water instead of

the reel. Water is introduced under pressure through a slit nozzle welded into the side of the tank, and is directed against the bottom and to one side in such a way as to set up a swirling motion. The tank is only about $\frac{1}{4}$ in. larger in diameter than the reel which rests on a narrow ledge about an inch above the bottom.

Removal of Loose Water.—Although the use of centrifugal force is practicable with the 6-ft reel, it would require a large heavy piece of apparatus to handle the 30- or 50-ft reels, weighing about 3 and 4 lb, respectively. Experiments showed that the required force parallel



FIG. 3. The processing and washing tanks with a reel in position. Temperature control tank in foreground.

to the axis of the larger reels could be applied by repeatedly allowing them to fall 15 in. against a stop. Two methods were used, one involving uninterrupted bouncing against a spring buffer, and the other merely a succession of falls against a 1-in. thick sponge rubber buffer pad from which there was a smaller rebound (Fig. 4). The first method of bouncing could not be used with the 50-ft reel because it caused such a large elastic deflection of the outermost portion of the reel that some of the film would leave the tracks.

The sponge rubber pad was almost entirely satisfactory, provided the height of the fall was limited. Some difficulty was experienced, however, with partly full reels. This was overcome by crowning the buffer pad so as to reduce the force applied to the outer part of the

reel. High-speed motion pictures showed that the 2 reel sides were thus made to stay in phase. The crown was provided by inserting below the pad a sheet of stiffer rubber about $\frac{1}{16}$ in. thick and $\frac{1}{2}$ the diameter of the pad.

In order to have the reel strike the buffer pad squarely, it was guided down a stainless steel rod mounted in a low tripod base which also supported a canvas reinforced bakelite table to which the pad was cemented.

Drying.—Even though loose water is removed successfully, drying on the reel without the aid of a fan is extremely slow, undoubtedly because the arrangement of the film hinders diffusion and convection. However, drying progresses satisfactorily if a small current of air is forced through the reel. Depending upon the conditions in the room and the nature of the work, a dust filter may be needed on the fan system. Where rapid drying is desired it is necessary to increase the air velocity and sometimes also to raise the temperature.

Several types of rapid driers have been used in different situations. In the simplest type, the reel is placed in a cup-like receptacle mounted directly on the intake of a small centrifugal blower placed with its axis vertical. For the 30-ft reel, a drier was built which has the reel receptacle in a table top and the blower and filter below it. Another design for heavy-duty service is shown in Fig. 5.

In this model, receptacles for two 50-ft reels are let into circular openings in the bottoms of each of 2 drawers, one of which is shown

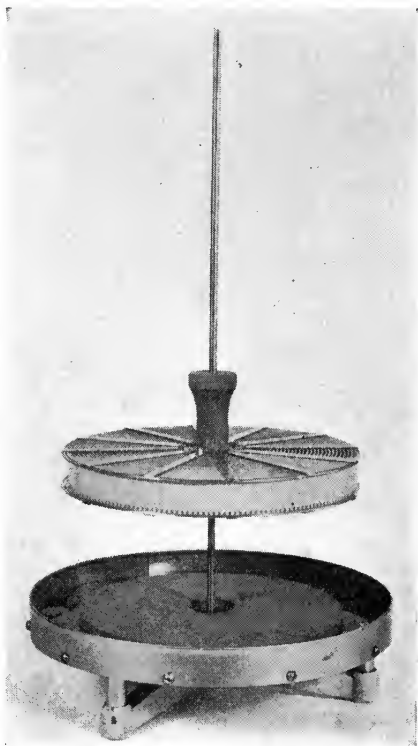

FIG. 4. The loose water stripper.

open in Fig. 6. Air from the blower in the bottom of the cabinet passes through the 2 drawers successively after traversing a filter of the viscous impingement type located just below the lower drawer. In a recess above the upper drawer are the thermostat and the handle of a by-pass damper. Air intake and exhaust connections are at the top. Recirculating air leaving the upper reel passes a thermostat



FIG. 5. Drier for two 50-ft reels.

bulb and the damper, and then goes down at the back past the heaters to the blower intake. Four switches on the front permit selection of the best heater wattage for smooth regulation while the thermostatically controlled switch is in series with all of them.

The arrangement of having the drying air pass through the 2 reels in succession is unobjectionable because the rate of evaporation is slow relative to the rate of air flow.

Method of Use.—Film to be loaded on the reel is placed on the supply spindle of the loading rewind (Fig. 2) with the emulsion side of the film uppermost, and the end of the film is led between the 2 guide rollers. After an attachment hole is made with the punch, the end of the film is inserted into the guide which is held so that

the open side is upward. The film supported by the guide is passed between the sides of the reel and brought down against the core where the attachment hole engages a pin in the hub as soon as rotation of the reel is begun. To assure success, the end of the film is first pressed down flat against the hub. Rotation is continued with the aid of the removable crank until all of the film is wound on. During loading the guide is supported by the film which is kept under light tension by contact of the left hand with the supply spool.

Adequate agitation in the baths for most purposes is provided by periodically lifting the reel about 1 in. on the guide post and then lowering it with a *clockwise* twist.* This is repeated several times in the first 15 sec and then once every 15 sec, or at least 7 to 10 times during development. This manner of agitation seems to be the most practical and effective one. The frequency required depends upon the degree of uniformity desired.

The reel is removed from each bath 7 to 8 sec previous to termination of the time of treatment and held at an angle to promote draining so as to minimize the amount of liquid carried over to the next bath.

The reel remains stationary for the duration of washing which, at the rate of $1\frac{1}{2}$ to 2 gal per min, takes about 5 min for Eastman release positive film Type 1301 when ordinary nonarchival use is intended.

After the loaded reel has been washed, it is bathed for 2 min in a 0.2 per cent solution of 28 per cent ammonia in distilled water to facilitate removal of water drops from the emulsion surface and prevent spotting by water residues.

Removal of loose water begins, of course, with thorough draining. The 50-ft reel is then placed on the water stripper and dropped through a distance of 15 in. about 20 times, after which it is ready to be dried.

Unless the image consists mostly of unexposed area it is difficult to determine when the film in the reel is dry without unwinding it.



FIG. 6. Open drawer of drier showing processing reel in place.

* Rotation in the opposite direction with the spiral reel in question tends to dislodge the outermost convolution of the film.

Therefore, unless ample time can be allowed, the necessary drying time should be determined by trial in advance for a range of atmospheric conditions and for the various types of film to be used. This is essential if handling of the film while it is wet is to be avoided entirely.

In rewinding the dry film from the spiral reel to the camera spool, the guide and rollers are not used. One of the removable cranks is fitted for frictional engagement with the spool flange. The film is held taut by friction on the reel in this case.

Control of Quality.—It has been found that with fresh developer, density or gamma can be maintained constant in successive runs within about 5 per cent by careful timing and adherence to a routine of manipulation. In most cases it is preferable to replace the baths frequently rather than to use strong replenisher. The effect of the volume of liquid carried in from the preceding bath and that of the equal quantity carried out on the rack must be considered in estimating the life of baths. For the 50-ft reel, about 3 liters of bath are required to cover the reel and the carry-over is 80 cc with the draining technique described. For a 30-ft reel, the quantities are 2 liters and 60 cc, respectively.

Adjustment in the temperature of the baths is made conveniently while they are in the processing tanks by placing in them a small stainless steel vessel (Fig. 3) filled with hot or cold water. During short processing times the bath temperature usually does not change appreciably. For long periods when the room temperature is extreme, the processing tanks can be kept partially immersed in a water bath.

Uniformity.—While equipment of this type is not expected to provide an intensity of agitation comparable with that in the best modern developing machines, tests with both picture and flash exposed material have shown good uniformity. This method is superior to rack processing and should be suitable for motion picture use in many cases where machine processing is not available.

Mechanical Performance.—It has been found easy to gain practically complete freedom from finger marks, scratches, gouges, and more serious damage which occur with greater or lesser frequency in the use of most other types of batch-processing equipment. Film which has been processed on the spiral reel usually shows undeveloped or unfixed spots between the perforations and the edge of the film as a result of contact of the emulsion with the track.

When the film is wound emulsion side out, these markings are less frequent but the outermost convolution is not well protected and may receive somewhat different treatment. However, the racks have space for about 10 per cent more than their nominal footage capacity to provide for a protective outer wrap.

In order to insure successful loading, the correct spacing between the sides of the reel must be maintained at all times by gauging whenever there is any reason to suspect deformation. Reasonable care in handling the reels and storage in a safe place are about the only safeguards needed to prevent deformation.

Applications.—Still photography, instrument recording work, and many types of scientific photography in which precise control and careful handling are needed for lengths up to 50 ft would probably be served better by this class of equipment than by any other.

When other lengths and widths are to be accommodated, the design must be modified accordingly. Stiffness of the film causes such difficulty with 16-mm film that the loading method employed for 35-mm film appears impracticable even with a shallow track. While the present reel tracks can be used for widths up to a few inches, greater widths require a larger wire or a differently shaped wire to give a deeper track, so that allowance can be made for the transverse swelling of the film when it is wetted. The pitch of the spiral must also be increased for greater widths of film so that adjacent convolutions will not come into contact because of transitory irregularities in shape which occur during drying.

The 50-ft size appears to be about the largest 35-mm reel which is practical without increasing the rigidity of the spiral track assembly which would increase the volume of liquid carried over and might entail some difficulty in removing water. With modifications to provide rigidity, 100- and possibly 200-ft reels may prove to be workable provided loading can be carried out successfully. The capacity, of course, increases almost as the square of the diameter.

ACKNOWLEDGMENT

Grateful acknowledgment is made of the assistance of Mr. V. J. Moyes in the selection of a suitable reel track construction and that of Mr. L. D. Jackson in the drier design.

REFERENCES

¹ CRABTREE, J. I.: "The Development of Motion Picture Film by the Reel and Tank Systems" *Trans. Soc. Mot. Pict. Eng.*, No. 16 (May, 1923), p. 163.

WHITE, D. R.: "Equipment for Developing and Reading Sensitometric Tests," *J. Soc. Mot. Pict. Eng.*, **XXVI** (Apr., 1936), p. 427.

IVES, C. E.: "An Improved Roller-Type Developing Rack with Stationary Drive," *J. Soc. Mot. Pict. Eng.*, **XXXI** (Oct., 1938), p. 393.

LEONARD, R. S.: "A Reel and Tray Developing Machine," *J. Soc. Mot. Pict. Eng.*, **XXXIV** (Feb., 1940), p. 168.

"The Davidge Developing Apparatus," *J. Soc. Mot. Pict. Eng.*, **XXIV** (May, 1935), p. 452.

"Reelo Motion Film Tank," *Camera Craft*, **35** (July, 1928), p. 336.

EVOLUTION OF SCORING FACILITIES AT COLUMBIA PICTURES*

JOHN P. LIVADARY** AND M. RETTINGER†

Summary.—The first part of this paper deals with the scoring facilities available at Columbia Pictures in 1935, and the modification of the scoring stage built in that year to allow for the recording of larger bands. The second part describes the conversion of a production stage of 110,000 cu ft into a scoring stage, the advantages connected with the use of convex wood splays in such an enclosure, and the construction of a vocalist's room to allow the separate and simultaneous recording of songs, orchestras, and combined renditions of the two. A description of the electric circuits employed for mixing 3 tracks is included.

In 1935 Columbia Pictures built a scoring stage engineered to incorporate the latest principles of acoustic design known at that time. The volume of this stage was approximately 75,000 cu ft, large enough for a maximum of 25 musicians, employing the rule-of-thumb figure of 3000 cu ft per musician. Although highly satisfactory, particularly for orchestras of 15 to 20 men, this stage later proved inadequate when orchestras of 35 to 50 men were to be accommodated. Until space could be found to construct a larger scoring stage, the Columbia Sound Department was compelled to adopt temporary measures to minimize the undesirable quality of sound resulting from overcrowding the stage, and to seek means for increasing its reverberation time, particularly in the mid-range and at the high frequencies, since these periods were considerably lowered by the presence of a large group of people in the room.

To reduce the somewhat undesirable effects of the low-frequency reflections in the studio, the back wall and $\frac{1}{3}$ of each of the adjacent walls were considerably deadened by covering these surfaces with 4 in. of mineral wool. To increase the reverberation time which had been still further reduced by the above treatment, wooden columns of various diameters were stationed around the walls of the orchestra

* Presented Oct. 19, 1943, at the Technical Conference in Hollywood.

** Sound Department, Columbia Pictures Corporation, Hollywood.

† RCA Victor Division of Radio Corporation of America, Hollywood.

shell. These columns ranged from 2 to 3 ft in diameter and from 10 to 20 ft in height, and were placed at a distance of from 3 to 5 ft from the walls of the stage.

This treatment improved the acoustics of the studio considerably and made it possible to record orchestras up to 35 men with reasonable satisfaction. Simultaneously, the beneficial effects resulting from the introduction of the columns in the room were discussed with both ERPI and RCA acoustic engineers and it was generally agreed that the idea had merit. Soon after, in 1938, Paul E. Sabine¹ wrote a paper entitled "Effects of Cylindrical Pillars in a Reverberation Chamber" which theoretically and experimentally supported the idea of using cylindrical pillars for the improvement of sound decay characteristics in a room. However, owing to the fact that the columns reduced the volume of the room and were seriously interfering with the seating capacity of the orchestra, this arrangement was considered a temporary remedy only.

Between 1939 and 1941, Walt Disney Studios, in conjunction with RCA acoustic engineers,^{2,3} built 2 scoring stages using cylindrical splays in the bandshell. These stages, probably the first local music recording studios utilizing curved wood surfaces in the orchestra shell, employed 2 different constructions for the convex splays. While plywood was used for both types, the curved surfaces in the first stage consisted of two $\frac{1}{4}$ -in. sheets nailed securely to so-called saddles or horizontal planks of wood cut to the cross-sectional shape of the splay. The second type of splay consisted of a single sheet of $\frac{3}{8}$ -in. plywood sprung into 2 \times 3-in. upright wood studs containing a $\frac{3}{8}$ -in. groove.

In 1940 the space limitations of the Columbia scoring stage necessitated the conversion of an existing small production stage into a scoring stage to allow the recording of larger orchestras. The volume of this room was about 110,000 cu ft thus offering facilities for the recording of orchestras of about 35 musicians. For the acoustic treatment of this stage, the use of curved splays, as employed in the above-mentioned 2 Disney stages, was considered desirable. While at the Disney Studio both the walls and the ceiling of the bandshells consisted of convex splays, because of the low ceiling of the production stage, it was not found practical to supply a splayed canopy for the orchestra shell in this second Columbia scoring stage. The curved flats were therefore installed on the walls only, in clusters of 16 \times 16 ft, each made up of individual units 4 \times 8 ft at right angles to each other.

While the advantages of curved splays have lately been discussed in some detail in 2 articles,^{2, 3} it may be well to summarize the outstanding qualities of this construction:

(1) More uniform distribution of sound pressure owing to the longer wave front of the reflected sound, a factor of particular importance in connection with high frequencies. As is well known, the wave front of a beam of sound reflected from a convex surface is considerably longer than that from an equally large flat surface provided that the wave length of the incident sound is small compared to the dimensions of the reflecting surface. Depending on the frequency, an increase in wave front length of from 2 to 3 times over that from a flat surface can be realized in this manner assuming, of course, that the source of sound is at the same distance from both surfaces.

(2) Creation of surface sources of sound. The increase of diffusion of sound in the room obtained in this manner is of importance for the low frequencies, and is of special help in not making the microphone position critical for optimal pickup. It should be noted that the creation of surface sources can be obtained only when the splays are able to vibrate as otherwise they would act as pure reflectors. It should further be observed that wood represents the preferred material for this purpose since it is able to vibrate over a wide range of musical pitch, unlike a panel of plaster or fiber board. The energy employed to set the sheet of wood into vibration is partly reradiated in a manner which need not follow the regular law of equal angle of incidence and reflection. A vibrating surface of this type, because of its size and shape, may therefore emit plain or cylindrical waves even though excited by spherical ones.

(3) Provision of a wall or ceiling section which is more absorptive for the low than for the high frequencies. The fact that work is done on the panel in moving it and that sound is radiated from the back as well as from the front describes the splay as a relatively efficient low-frequency absorbent. A search through a list of available commercial acoustical materials will readily indicate that practically all of them show higher absorptivities for the mid-range than for the low frequencies. Where it is important therefore to reduce the low-frequency reverberation in a room to a minimum, the use of vibrating membranes represents practically the only satisfactory solution.

(4) Reduction of interference effect between direct and reflected sound. This effect may be ascribed directly to the longer wave front of the reflected sound from a convex splay, since the energy of a propagating wave front varies inversely with the square of its length.

(5) Production of a relatively smooth sound decay curve. This condition can only be attributed to greater diffusion of sound in the room occasioned by surface sources, extended wave fronts, and irregular wall contours in general.

(6) Erection of reflective surfaces which minimize echo. Next to nonparallel walls, the most economical solution for avoiding echoes in a room consists in the provision of an irregular wall contour, as long as this wall is meant to be kept reflective. Parallel walls can of course be treated acoustically to eliminate echo effects between the surfaces, an expedient which does not readily lend itself to the construction of bandshells that should contain sufficient localized reverbera-

tion to allow the musicians to stay in tune and in time, and to play with appropriate intensity.

In the construction of the bandshell for the second Columbia scoring stage, the effect of the resonant frequencies of the wood splays was carefully considered, and was not held detrimental. Splays of this type have many resonant frequencies. These frequencies are not harmonically related, and their amplitude distribution is made up of various modes of vibration. Moreover, nodes are not sharply defined owing to the presence of more than one mode. The only pronounced resonance to which a splay of this type is subject is that produced by the air chamber in back of it. Care was therefore taken to place the curved wood splay against an absorbent wall surface to avoid a so-called "hang-over" effect, or prolonged reverberation in the space between wall and splay.

As time went on it developed that in the recording of a vocalist accompanied by a large orchestra, this second stage proved too small to provide sufficient acoustic separation between the microphone for the vocalist and that for the orchestra. As a result thereof, it was decided during the latter part of 1938 to build within the scoring stage a separate all-enclosed vocalist's room similar to that in a broadcasting station. The dimensions of this room were approximately $15 \times 18 \times 20$ ft. It was so constructed that no 2 opposite walls were parallel to each other, including the ceiling and the floor. In this way echoes and standing waves were eliminated, and reverberation was adjusted to about 0.45 sec as against the reverberation time of the scoring stage itself of 0.95 sec.

The vocalist's room was set up adjoining the orchestra shell, and monitoring for the vocalist was effected through an adjustable window in the wall between the room and the bandshell. By the use of unidirectional microphones facing away from the monitor window, the singer's voice could be recorded with an orchestra level at the ears of the singer of about 15 db below the level on the scoring stage, while the orchestra level picked up at the vocalist's microphone was 10 db lower still, or about 25 db below the recorded orchestra level on the scoring stage.

The innovation provided some very interesting features so far as it permitted the recording of a singer and the orchestra on independent channels with practically complete acoustic separation to the point where either the singer's voice or the orchestration could later be replaced by another, if necessary. This development led to the evolu-

tion of a multichannel scoring setup by means of which 3 sound tracks can be recorded simultaneously by one mixer in the following manner: The microphones in the vocalist's room are brought into a mixer panel from which the output goes directly into the vocalist's recording channel to be properly equalized and amplified before delivery to the film recording machine. Similarly, the various orchestra microphones are fed into an adjacent mixer panel, the corresponding output of which is similarly routed to the music channel for proper equalization and amplification before delivery to the recording machine.

Two volume indicators bridged at the bridging "bus" of the vocalist and orchestra channel are carried back to the mixing panel for indication of recorded signal strength in each channel. A bridging amplifier from the music channel feeds back the output at the music bus to the mixer where the gain of the bridging amplifier is neutralized, and where its output can be reduced by a subdial installed alongside the inclusive volume dial of the music mixer panel.

The output of this special dial is delivered to the amplifier room where it is combined with the output of a bridging amplifier from the vocal channel. This combined output feeds a third bridging bus adjusted to a level of 2 db lower than the buses of the vocal and the orchestral channels. The third bridging bus supplies monitoring level for the mixer, feeds the bridging amplifier of a third recording machine in which the combination of vocalist's and orchestra's output is recorded, and also provides signal level for an acetate playback machine. Examination of this arrangement shows that the mixer may reduce the music level to the barest accompaniment requirements for the singer's voice, while simultaneously he can provide a level in the orchestra channel which is satisfactory for re-recording purposes later. This scheme, in addition to providing separate sound tracks for the vocalist and the band, also produces a sound track containing a combination of the two which is approved by the musical director, but does not bind the Music Department to retain the balance obtained during the scoring session, as it permits the reinterpretation of the musical rendition at a later date during re-recording. This is quite important because at the time of pre-scoring it is frequently very difficult to know how a musical sequence will be handled later since it is almost impossible to anticipate the requirements for pictorial perspective.

It is also evident that one mixer actually serves the purpose of three, resulting in economy of production. Furthermore, the vocal-

ist's booth saves considerable scoring time by providing fixed conditions under which the vocalist is recorded. In addition to the above, by the ability of establishing the desired reverberation time in the vocalist's booth, it is possible to preserve the speaking characteristic of the singer's voice and not to cause an undesirable difference between his recorded speech on the production stage and his singing voice on the scoring stage.

REFERENCES

¹ SABINE, P. E.: "Effects of Cylindrical Pillars in the Reverberation Chamber," *J. Acous. Soc. Am.*, **10** (July, 1938), p. 1.

² VOLKMANN, J. E.: "Polycylindrical Diffusers in Room Acoustic Design," *J. Acous. Soc. Am.*, **13** (June, 1942), p. 90.

³ RETTINGER, M.: "A Modern Music Recording Studio," *J. Soc. Mot. Pict. Eng.*, **XXXIX** (Sept., 1942), p. 186.

IMPROVEMENTS IN DISNEY SCORING STAGE*

C. O. SLYFIELD**

Summary.—This paper gives some of the details of the construction of 2 shells at the Walt Disney Studio—one temporary and one permanent—and modifications which were made in the permanent installation to obtain the best acoustic balance for orchestra recording.

In the fall of 1939, the construction of the present Disney scoring stage was rushed to make it available for recording the music for our then current feature, *Pinocchio*. The original plans for the interior acoustic treatment of the dead end of this stage called for a 2-in. rock wool blanket that was to be stripped with 1 × 1-in. wood strips over the tops of which muslin was to be stretched. The muslin was to be sprayed with enough thin coats of paint to close the pores of the material to give the desired diaphragm effect in dissipating the low frequencies, and give sufficient high-frequency reflection which would result in a pleasing over-all acoustic balance for the stage. Each coating of paint was to be thin so that the proper degree of high-frequency reflection could be obtained without exceeding the desired amount. However, time became short and it was necessary to improvise a treatment which would serve the purpose to a degree and be more readily and easily applied.

The treatment consisted of placing alternate sheets of painted Celotex, about one foot wide and spaced approximately the width of the sheets, on the sides, back wall, and ceiling. After this treatment had been applied, the stage still seemed too dead for good orchestra recording. To further increase the reverberation time, several strips of 1/4-in. plywood were placed at various spots between the Celotex sheets. With the completion of this part of the treatment, the stage seemed to have approximately the reverberation time which we had anticipated, and acoustic measurements were made. The result of these measurements (Fig. 1) was very gratifying and

* Presented Oct. 19, 1943, at the Technical Conference in Hollywood.

** Walt Disney Productions, Burbank, Calif.

showed that the measured reverberation characteristic followed closely the contour of the average optimum curve¹ for a stage of this size (100,000 cu ft).

It will be seen that the measured reverberation time was somewhat lower at the low frequencies, rose to a point which closely approached that of the average optimum curve between 1000 and 4000 cycles, and fell off moderately on the high end.

Under these acoustic conditions, the music score for *Pinocchio* was recorded. At that time we were pleased with the results which

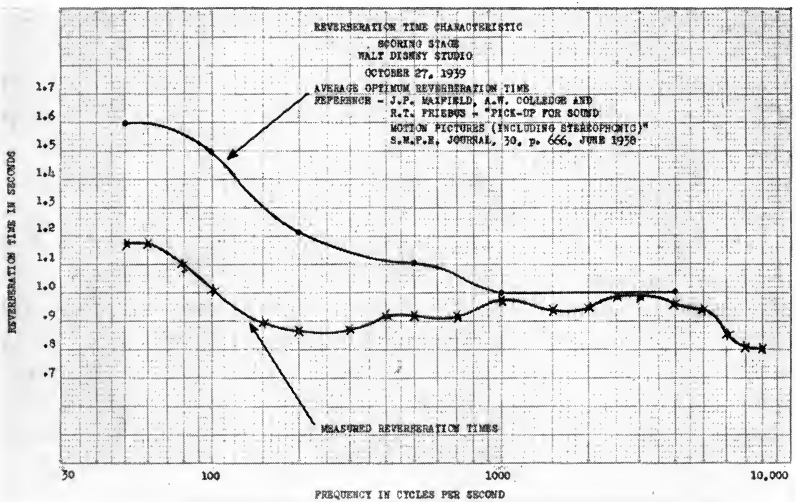

FIG. 1.

seemed to be as good as, or superior to, the results which had been obtained on the scoring stage of our Hyperion Avenue plant. In view of this, it was decided that nothing further should be done on the acoustic treatment until such time as we had accumulated enough recording experience on this stage to indicate just what measures were necessary to improve its reverberation characteristic.

In the meantime, we constructed a portable shell on our large stage which was to be set up temporarily for the purpose of recording a larger orchestra than could be conveniently accommodated on our regular scoring stage. The stage on which this shell was erected measures 120 ft long, 80 ft wide, and 40 ft high. The shell was set up

in one end of the stage and was constructed of curved sections similar to those used on our regular scoring stage. The curved units were built of two 4 × 8-ft pieces of $\frac{3}{8}$ -in. plywood making each vertical member approximately 4 × 16 ft. The individual sections were dampened by cross braces at irregular intervals, spaced by two $\frac{1}{2}$ -in. pieces of Celotex and bolted together to form the sides and back. The side and back sections were all of the same height.

The top of the shell was built of similar sections and suspended above the sides in such manner that the front edge of the top was approximately 12 ft higher than the back. The top of the shell was not attached to the sides or back at any point. In back of the triangular openings between the top and sides of the shell, the stage was treated with 4-ft widths of 1-in. rock wool blanket, spaced the width of the blanket, which made this area comparatively dead.

The first orchestra recording in this shell turned out exceptionally well. The music directors and musicians were enthusiastic about the results and felt that the acoustic balance within the shell was very good. This was immediately apparent to them as the shell provided a place in which it was easy to play and orchestra balance was obtained with little difficulty.

Shortly after this we were preparing to record the music score for *Bambi* and, inasmuch as a large part of the score was to appear under dialogue, it was decided to record the score in this new shell on the larger stage, where a much greater amount of natural reverberation could be obtained. A large part of this score was recorded with a single microphone placed approximately 50 ft from the front of the shell. Orchestra balance on this production was easily obtained and the recorded results were all that had been expected.

There are 4 main reasons, in my opinion, for the good performance of this shell:

(1) The shell was constructed of lighter material ($\frac{3}{8}$ -in. plywood as against two $\frac{1}{4}$ -in. pieces glued together) than our regular scoring stage shell, and was not so rigidly braced. This construction not only allowed the panels themselves to vibrate but, to a certain extent, permitted the whole structure to vibrate which assisted in dissipating the low frequencies.

(2) The top not being bonded to the sides made possible the independent vibration of this element.

(3) About the right amount of absorbing material was used on the insides of the stage directly behind the vertical sections of the shell and the openings between the top and sides.

(4) The shell was used on a stage of fairly large cubic content (384,000 cu ft).

After hearing the result of our *Bambi* recording which was done in this new shell, it became apparent to us that the low-frequency reverberation time on our regular scoring stage was excessive. This resulted in orchestras being difficult to balance, especially small orchestras such as are used for our shorts. This condition was indicated by what our musicians termed "swimminess" appearing in the lower frequency range. Our first attempt to rectify this trouble consisted of the application of $\frac{1}{2}$ -in. Ozite blankets to alternate vertical curved members of the shell, stripping the Ozite with 1×1 -in. wooden strips and stretching muslin tightly over the tops of the strips. The muslin was then sprayed with a thin coat of paint to give it the diaphragm effect at low frequencies, and the high-frequency reflecting properties previously mentioned. The Ozite, which was on hand and readily available, was used to avoid a standing wave system at the high frequencies between the curved splays and the muslin.

This change brought about a very definite improvement. However, the undesirable effect of excessive low-frequency reverbation had not been completely eliminated. To further control this condition, the back and side walls of the stage opposite the shell were treated as originally planned; that is, 1×1 -in. wood strips applied over the rock-wool blanket with muslin stretched over the strips and painted.

At the rear of the shell there are 2 large doors measuring 8×16 ft each which open to expose a screen when a picture is to be used in conjunction with recording. These doors are now covered with Celotex on both sides. We are planning on covering the backs of these doors with Ozite, stripping and applying muslin and painting as previously mentioned. This modification will provide a short reverberation time at the low frequencies and make it possible to have either the Celotex fronts or the treated backs of these large doors presented to the back of the shell, and provide the flexibility often required in orchestra recording.

The treatment which we have applied to this stage has improved the acoustic balance appreciably. However, I am sorry to state, no quantitative measurements have been made to substantiate this statement and to indicate definitely the amount of improvement which has been accomplished.

It will be noted that the low-frequency reverberation time for this stage was lower than that indicated on the average optimum curve

shown in Fig. 1, but was still too high for best results in orchestra recording.

The shell in which the *Bambi* score was recorded was recently sold to Paramount Studios in Hollywood where it has been erected on their scoring stage in a manner similar to the original setup. The shell is nicely installed in its present location and, from all reports, is turning out results which are highly gratifying and giving a good account of itself.

I wish to take this opportunity to thank the Engineering Staff of RCA in general and Mr. M. Rettinger in particular for their very helpful suggestions for improving the performance of our scoring stage shell.

REFERENCE

¹ MAXFIELD, J. P., COLLEDGE, A. W., AND FRIEBUS, R. T.: "Pick-Up for Sound Motion Pictures (Including Stereophonic)," *J. Soc. Mot. Pict. Eng.*, **XXX** (June, 1938), p. 666.

ACOUSTIC CONSIDERATIONS IN THE CONSTRUCTION OF VOCAL STUDIOS*

E. B. MOUNCE,** CLEM PORTMAN,** AND M. RETTINGER†

Summary.—The paper describes the purpose of the vocal room of the RKO Studios, and the factors involved in providing satisfactory acoustics for this room. In particular, to avoid coincident reinforcement of the normal modes of vibration, the ratio of the height, width, and length of this (small) enclosure was made to vary with the $2/3$ power of 2.

For the recording of vocal numbers, it is frequently desired to pick up the song and the instrumental accompaniment with separate microphones. When singer (or chorus) and orchestra are in the same room, it is sometimes difficult to obtain sufficient "acoustic isolation" between the microphones to permit the mixer to raise or lower the vocal rendition separately. For, even though the gain control of the instrument microphone channel is lowered, for instance, there may yet be a sufficiently high music level at the singer's position to prevent a predominant recording of the song only. While it is possible to "tone down" the orchestra as a whole whenever the recording level of the song is to be raised, it has frequently been found more convenient to place the singers in another room separated from the music recording studio by a wall containing a window large enough to allow the singer and the conductor to see each other.

Such a setup requires that the conductor in the scoring stage be able to hear the vocal section in addition to his instrument section, and also that the singer or singers be able to hear the orchestra in order to stay in time. This condition is frequently attained when both the conductor and the singer are wearing earphones connected to the appropriate microphones set up in the scoring stage and in the vocal room.

For the recording of certain vocal numbers it may also be possible

* Presented Oct. 19, 1943, at the Technical Conference in Hollywood.

** RKO Radio Pictures, Inc., Hollywood.

† RCA Victor Division of Radio Corporation of America, Hollywood.

to provide a small adjustable opening in the wall between the chorus room and the scoring stage to allow just sufficient infiltration of instrumental music into the vocal studio to permit the singer to keep in tune. This setup still requires the conductor to listen to the vocal section over earphones since the sound level of the band at the conductor's position may be considerably higher than the sound level of the singer, while in the chorus room the sound level of the instrument section may be controlled by means of the adjustable opening. Experiments along this line, however, have not been conclusive at the RKO Studios. In the same manner it has not been proved conclusively whether a public address system in the chorus room will provide sufficient monitoring control for the singer.

In the case of small enclosures such as chorus rooms, it becomes important to regard the phenomenon of "room resonance" with considerable attention. Large rooms are much less troubled with the coincident reinforcement effects of the normal modes of vibration, because there exists a relatively large number of them within any given frequency interval of the recording spectrum. The number of normal modes in the range between the frequencies F and $F + dF$ is given by the equation

$$dN = \frac{4 VF^2 dF}{C^3} \quad (1)$$

where V is equal to the volume of the room and C to the velocity of sound. Thus, between 80 and 120 cycles a room of, say, 3000 cu ft has 6.7 normal modes while a room of 30,000 cu ft has 67 normal modes. For good hearing conditions, a large number of such "eigen-tones" are preferred, for if a complex tone is generated in such a large room, a sufficient number of modes will coincide with the components of the sound to be reinforcing it uniformly.

For a small room, therefore, it is desirable to spread its few low-frequency resonances as uniformly as possible through the frequency intervals. The normal modes of vibration are given by the equation

$$f = \frac{c}{2} \sqrt{\frac{p^2}{h^2} + \frac{q^2}{w^2} + \frac{r^2}{l^2}} \quad (2)$$

where h , w , and l = height, width, and length of room; p , q , r = integers.

Consideration¹ of the above equation shows that coincident reinforcement is avoided when the elements of the ratio $h:w:l$ vary with

the $\frac{2}{3}$ power of 2. The following proportions, therefore, are suggested for the principal dimensions of a parallelepiped enclosure:

$$1:1.26:1.6=1:\sqrt[3]{2}:\sqrt[3]{4} \quad (3)$$

$$1:1.6:2.5=1:\sqrt[3]{4}:\sqrt[3]{16} \quad (4)$$

$$1:1.6:3.2=1:\sqrt[3]{2}:\sqrt[3]{32} \quad (5)$$

In the construction of the RKO chorus room, the second of the above ratios was employed to provide the mean dimensions for the enclosure. It should be kept in mind, however, that these dimensions represent mean values because it would be highly undesirable to employ a strictly parallelepiped room for a vocal studio. Such a room would be troubled with echoes which could be eliminated only by making the walls highly absorbent thereby possibly leading to a room having a reverberation time far below the optimal one. For this reason, nonparallel walls represent in many instances the most economical solution for the avoidance of such echoes.

Construction of such a room does not require excessive acoustic wall treatment, thus providing the room with a desirable reverberation. A singer in a "dead" room not merely has difficulty adjusting the volume of his voice for an adequate rendition, but also finds it difficult to stay in tune and in time. It is indeed desirable sometimes to select a reverberation time for the vocal studio which approaches the upper limit of the optimal reverberation time range specified for small rooms. To avoid too high a ratio of reflected-to-direct sound at the microphone, the microphone distance must be kept rather short—a condition to which many singers are not averse. Anyone familiar with the recordings of songs has, no doubt, observed the tendency of a singer to approach a microphone more and more during a rendition. This condition requires some attention on the part of the mixer when a velocity microphone is being employed since a decrease in microphone distance will produce an accentuation of the low frequencies. On the other hand, a velocity microphone permits the use of a longer microphone distance as compared to a pressure microphone for the same allowable ratio of reflected-to-direct sound.

REFERENCE

- ¹ VOLKMANN, J. E.: "Polycylindrical Diffusers in Room Acoustic Design," *J. Acous. Soc. Am.*, 13, No. 3 (Jan., 1942), p. 234.

THE VOCAL ROOM AND PRE-SCORING OPERATIONS AT RKO RADIO PICTURES*

E. B. MOUNCE,** CLEM PORTMAN,** AND M. RETTINGER†

Summary.—Details of operation of the permanent, acoustically designed vocal room at RKO Studios, and the electric circuits used for the recording of vocal and orchestra numbers are described.

The flexibility of the methods used by RKO Studios for pre-scoring musical-vocal numbers has recently been improved by the installation of a vocal room as an integral part of the scoring stage. When scoring an orchestra and one or more vocalists, it has been the practice to record the orchestra on one film channel and the vocalists on a second or separate film channel. This method permits great latitude in musical balance when the 2 sound tracks are later dubbed together. In addition, unrestricted alterations in frequency characteristics and compression ratios may be made on either sound track during and after the scoring session.

To be successful, the separate channel method requires the fulfillment of 2 conditions. One is that the vocalists must at all times hear the orchestral accompaniment distinctly and with sufficient volume to enable them to maintain pitch and ensemble. The other condition requires a high degree of acoustic isolation between the microphones of the 2 channels so that the leakage of the orchestra into the voice channel does not impose limitations upon the most effective monitoring of either channel.

Prior to the installation of the RKO vocal room a fair amount of acoustic isolation or separation between the 2 channels was obtained by the makeshift method of surrounding the soloist or chorus with a number of acoustical panels. Quite often this separation was not sufficient to provide adequate control of the vocal-orchestral balance. The orchestra was then called upon to play at lower and

* Presented Oct. 19, 1943, at the Technical Conference in Hollywood.

** RKO Radio Pictures, Inc., Hollywood.

† RCA Victor Division of Radio Corporation of America, Hollywood.

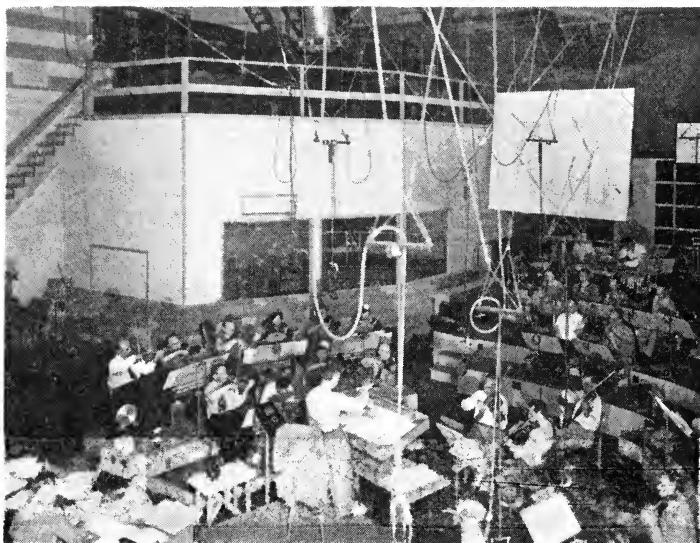

FIG. 1. Exterior of vocal room on music stage.



FIG. 2. View of conductor and singer from conductor's stand.

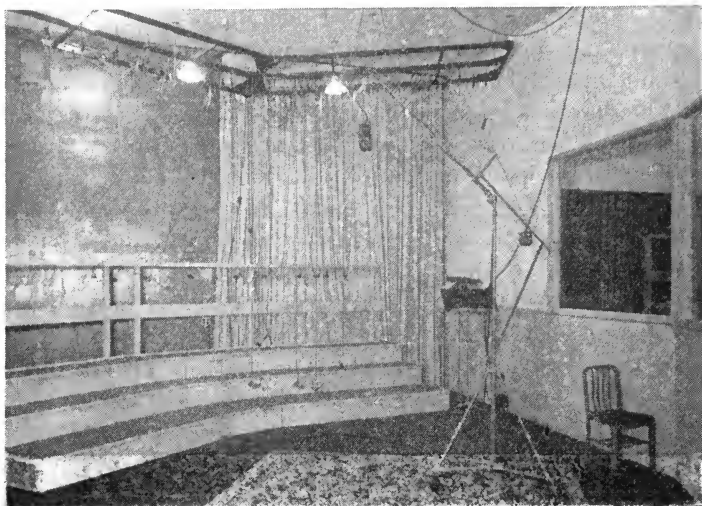

FIG. 3. Interior of vocal room.



FIG. 4. View of singer and conductor from singer's stand.

sometimes unnaturally low levels. Under these conditions the performance of the vocalists became increasingly difficult owing to the diminishing of a solid orchestral support, and the whole setup usually resulted in a precarious compromise.

To improve operations and obtain a much higher degree of acoustic isolation in forthcoming musical productions, it was decided to install on the scoring stage, a permanent, acoustically designed vocal room large enough to accommodate several soloists and a chorus of approximately 30 vocalists. This room, designed to our specifications by Mr. M. Rettinger of RCA-Victor, is now in operation and has proved highly successful. Using a peak reading volume indicator and assuming zero level as a reference for 100 per cent, or full track recording, the amount of orchestral leakage observed in the voice channel varies from -30 db, in the case of a large orchestra playing at high levels, to -50 db for a small orchestra or soft rhythm accompaniments.

Although the voice and orchestra are actually recorded on separate tracks, monitoring is accomplished by bridging the monitor speaker across both channels. In this way, orchestral "fills, bridges, open figures and ride-outs," used to accentuate rhythmic values in vocal numbers, are balanced in direct and audible relation to the vocal channel. The result of this composite monitoring is recorded on an acetate playback for immediate demonstration and analysis.

The vocal room has large double-glass windows giving unobstructed vision between the singers and the musical conductor. The conductor and the singers are supplied with headphones bridged across their opposite channels so that each may hear the other at his own selected level. A specially constructed stage platform divided into 3 movable sections has been provided to insure rapid physical arrangement of a chorus during the preliminary balancing process. The headphones for the chorus are suspended from an overhead framework designed to prevent the phones and cords from becoming entangled.

In the monitor room, equalizers, compression controls, and separate volume indicators are provided for each channel. A public address system furnishes intercommunicating facilities between the monitor room, the vocal room, the recording room, and the conductor.

(*Ed. Note:* A combined musical-vocal sound track was projected to demonstrate the amount of acoustic isolation obtained by use of the vocal room. At intervals, the vocal and music channels were individually withheld from the composite track.)

NEW SCORING STAGE SHELL AND VOCAL STUDIO DESIGN*

LOREN L. RYDER**

Summary.—Many of the early musical recording techniques and scoring stage designs were natural consequences of early equipment limitations and the early technical approach to the general problem of music recording. Present-day equipment has lifted many of the technical restrictions, thus making desirable a reconsideration of musical recording, especially as related to the musician's problem, his ease of playing, and the acoustics which aid the musicians in playing together for an over-all effect.

This paper points out how past practices have restricted our musicians, and suggests ways of gaining greater freedom and better music to the microphone.

In my discussion I hoped to convey to you our thinking—our analyses of the problems of music recording for motion pictures, and what we are doing about them. Why are we coming back to the old band shell and the symphony stage setup of several decades ago?

Our past schemes of music pickup have demanded special grouping and separation of musicians as an accommodation to our microphones and recording rooms. In fact, we have done nearly everything that could mitigate against good playing and good music.

In a dead stage, the musicians force their playing in order to hear their own instrument, and seldom heard much else. When grouped they play as groups but not as an ensemble.

Our approach has been to ask the musicians "On what stages do you most enjoy playing?" "On what stage is it the easiest for you to play?" "In the different places where you have played, where did the music feel best to you?"

Many of the answers included symphony stages and old bandshells, but the majority of the votes went to the Disney *Fantasia* shell. Next, we employed an acoustical expert and convinced ourselves that the musicians' judgment was correct. Then we approached Mr. Disney and purchased the shell.

Along the way we defined our secondary objectives and set out to

* Presented Oct. 19, 1943, at the Technical Conference in Hollywood.

** Paramount Pictures, Inc., Hollywood.

obtain them. We had evidence to show that the music would sound right to the musicians and that they would enjoy playing in the shell. We were also sure that good, large orchestra recordings had been obtained for the picture *Fantasia*.

The next objective was to make sure that the music would sound right at the conductor's stand. In other words, the conductor should hear the same balance and effect that is to be recorded. If the music did not sound right to the conductor, he would know it and do something about it. If it did sound right, our job is to record what the conductor heard; this is a little idealistic.

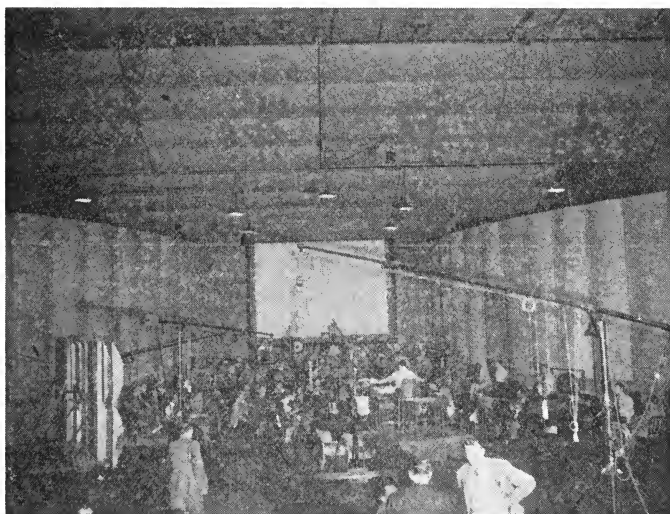

FIG. 1. Scoring stage shell at Paramount Studios, showing auxiliary reflector at left.

To accomplish this we flared the shell a little more than had been done for the *Fantasia* recordings, but to be safe we left both the walls and ceiling jockey—movable. We have jockeyed them and brought them back to their previously calculated positions.

Our third objective was to gain control over orchestra brilliance and room reverberation.

I should stop here and point out that both our shell and the stage were engineered for the maximum desired brilliance and reverberation, anticipating the use of drapery for control by absorption. In our experience we normally cover most of the back wall, but if we

desire a long period, slightly "echoy" reverberation, we pull back this drapery until the desired effect is obtained. For the most part we control what might be called *room tone* with the drapery on the east side wall, and we control the brilliance and short period reverberation effect of the shell by draperies which pull in from either side at the front of the shell opening. In our recordings to date we have operated within the range of these controls, which has been very gratifying.

Our fourth objective was to be able to use the stage for both large and small orchestra groups.

Here again we protected ourselves by the jockey walls and ceiling, but approached the problem on the basis that if the music of each player sounded right for a large ensemble, then why would it not sound equally correct for a smaller group? After about 2 months of recording experience we firmly secured the walls and ceiling and to date have had no desire for a smaller stage. We do, however, drape in the shell more for smaller groups.

Our fifth objective was to obtain dual channel recording of orchestra and chorus.

In this we feel that again we have taken a brand new tack. We have asked "How will the chorus work and sound best?" The answer has long been demonstrated on the concert stage where the chorus is close to or with the orchestra, and where the conductor balances and blends them for a unified effect. We place both our chorus and orchestra in the shell. For this work the orchestra is arranged in the center, and to one side of the shell, while the chorus is placed on the other side and facing the conductor. The conductor balances his orchestra and chorus so as to obtain the desired musical effect as heard at the conductor's stand. Bidirectional microphones are used to obtain the greatest possible isolation between orchestra and chorus. The orchestra microphones are fed to one recording channel and the chorus microphones to a second channel.

It has been our experience that as long as the conductor obtains a desirable musical balance between the chorus and orchestra, the separation obtained by the directional effect of the microphones will provide sufficient latitude to accommodate all of the changes and balance which may be required for picture cuts favoring either the chorus or the orchestra. In this work care has always been exercised to make sure that the orchestra balance is correct within itself and not dependent upon microphone balancing as the leakage

to the chorus microphone must have a reasonable orchestra balance even though more distant in effect than the direct orchestra pickup.

In addition to offering the best system for rendition, both the orchestra and the chorus are working under desirable acoustical conditions and control. This arrangement eliminates the acoustical lag, obvious difference in acoustical surroundings and poorer renditions normally obtained when the chorus is boxed off in a corner of the stage. This has the obvious advantage over chorus post-scoring with earphones, where the orchestra track has been pre-recorded and cannot be made to give or blend with the voices.

Thus far our discussion has been largely applicable to legitimate playings, musical numbers, and normal underscoring. Where special musical effects or close-up solo instruments are desired, we bring in close-up microphones or segregate the musicians as in the past. As far as we know from the use of this stage, we have not limited the scope of musical punctuation, or restricted our ability to obtain special musical effects.

While we are discussing the shell, there is one other little adjunct—a reflector. If we have robbed the violin section in order to fill out the woodwind and brass, we use a reflector to build up the effect of the violin section.

Having been, let us say, reasonably successful in our orchestral and chorus endeavors, we then set out with the same approach for our solo vocal recordings. We asked our Paramount singers and other singers in the industry, "Where do you most enjoy singing?" Fortunately for us, many of these people pointed out relatively small broadcast studios and music studios in their homes, especially the studio in the home of Nelson Eddy. Again the technicians went to work, but this time we also called on the Art Department. It seems that Paramount had been calling on some of their highest paid talent to produce their greatest musical accomplishments in a draped-off corner of the scoring stage or in a padded cell, reminiscent of the earliest and crudest broadcast studios. The Paramount vocal studio—no longer called a vocal booth—has been patterned after Nelson Eddy's music room, and is in effect a room where a musician should enjoy singing with surroundings which should inspire rather than detract from his work.

I will point out several of the features incorporated in this room. The soloist stands where he can watch the conductor and listen to the orchestra over a loud-speaker. The loud-speaker is placed in the

general direction of the orchestra, but is also placed so as to produce a minimum pickup in the bidirectional vocal microphone. Earphone service is also provided but seldom used. A soft spotlight illuminates the singer so that he may be watched by the conductor who wears an earphone, monitoring on the vocal recording channel. In addition to a public address system for communication, there is an order wire system working between the conductor's stand, the scorer, and the studio so that the conductor and scorer may communicate with the vocalist or the vocal coach and work out their problems.

CURRENT LITERATURE OF INTEREST TO THE MOTION PICTURE ENGINEER

The editors present for convenient reference a list of articles dealing with subjects cognate to motion picture engineering published in a number of selected journals. Photostatic or microfilm copies of articles in magazines that are available may be obtained from The Library of Congress, Washington, D. C., or from the New York Public Library, New York, N. Y., at prevailing rates.

American Cinematographer

- 25 (Feb., 1944), No. 2
Acquiring Balance in Color (p. 47) F. M. HIRST
The Post-War Visual Education Potentialities in Latin America (p. 51) N. D. GOLDEN
25 (Apr., 1944), No. 4
Movies of Bullets (p. 114) R. H. BAILEY
Camera Planes Win Wars (p. 115)
The Camera and Projector of Tomorrow (p. 118) X. TOLL
Don't Forget Television (p. 120) J. LEAMAN
The Training Film that Trains (p. 122) B. A. FINDLAY

Educational Screen

- 23 (Feb., 1944), No. 2
Motion Pictures—Not for Theatres, Pt. 54 (p. 69) A. E. KROWS

Institute of Radio Engineers, Proceedings

- 32 (Apr., 1944), No. 4
Television Broadcast Coverage (p. 192) A. B. DU MONT AND T. T. GOLDSMITH

International Photographer

- 16 (Mar., 1944), No. 2
Future of Theatre Television (p. 11) H. DONALDSON
The Acme-Dunn Optical Printer (p. 18)

International Projectionist

- 19 (Feb., 1944), No. 2
The Projection Life of Film (p. 11) D. R. WHITE AND C. DEMOOS
Television Today, Pt. V—The Image Dissector (p. 12) J. FRANK, JR.
Motion Picture Projection in French North Africa (p. 18) A. NADELL
Motion Picture Film Regulations of the Underwriters Code (p. 21)

SOCIETY ANNOUNCEMENTS

PACIFIC COAST SECTION

It was the privilege of the Pacific Coast Section of the Society to welcome William Harcourt, Director of the Denham Laboratories, Denham, England, and an Active member of the Society. At present visiting in Hollywood, Mr. Harcourt consented to give the Section an informal, off-the-record account of motion picture production and laboratory operations in wartime England. His talk followed a dinner held at the Hollywood Athletic Club on May 2d.

F. H. RICHARDSON

The name of Frank H. Richardson was added to the Honor Roll of the Society by unanimous vote of the qualified members present at the General Meeting held on April 19th. The action taken during the recent Technical Conference followed the unanimous recommendation made by the Board of Governors at their meeting on January 26, 1944, to perpetuate the name of one of the active and loyal founder members of the Society.

Established in 1931, the Honor Roll appears on the back cover of each JOURNAL, Mr. Richardson's name being added in the May issue.

AMERICAN STANDARDS FOR THE JOURNAL

The Board of Editors has recommended that future issues of the JOURNAL conform with 2 American Standards adopted for scientific periodicals, namely: (1) Reference Data and Arrangement of Periodicals, ASA Z39.1-1943, and (2) Abbreviations for Scientific and Engineering Terms, ASA Z10.1-1941.

While the first Standard is concerned with data on arrangement of contents, pagination, identification, *etc.*, the second deals with items of interest to authors preparing technical manuscripts for publication. It recommends the use of certain engineering abbreviations, and outlines fundamental rules which the Board of Editors feels will improve the general usefulness and appearance of the JOURNAL.

Not all of the recommendations can be adopted, but it is hoped that authors will find the American Standards used in the JOURNAL satisfactory, and will incorporate as many of them as practicable in their original manuscripts.

Copies of the Standards may be purchased from the American Standards Association, 29 West 39th St., New York 18, N. Y.

CUMULATIVE INDEX, 1936-1940

The Board of Governors of the Society recently authorized compilation and publication of a cumulative 5-year index to the JOURNAL for the period of January,

1936, to December, 1940, inclusive. Now in preparation, one copy will be mailed to each member of the Society and nonmember subscriber to the JOURNAL about August 15th.

Additional copies may be purchased at \$1.00 each. Therefore, in order to estimate the quantity required, please notify the General Office of the Society immediately the number of extra copies desired.

We regret to announce the death of J. N. Gelman, Active member of the Society, on April 20, 1944, at Cincinnati, Ohio.

JOURNAL

OF THE SOCIETY OF

MOTION PICTURE ENGINEERS



AUTHOR AND CLASSIFIED
INDEXES

VOLUME 42

JANUARY-JUNE, 1944

AUTHOR INDEX, VOLUME 42

JANUARY TO JUNE, 1944

<i>Author</i>		<i>No.</i>	<i>Page</i>
BELL, R.	Making Films That Teach	2 (Feb.)	85
BLANEY, A. C.	Notes on Operating Experience Using the Direct Positive Push-Pull Method of Recording	5 (May)	279
BRADLEY, J. G.	Wartime Cataloging of Motion Pic- ture Film	3 (Mar.)	145
CARR, H. E. (and NELL, E., JR., and SARGENT, T.)	The Training Film Program in Action —A Case History	2 (Feb.)	93
CORCORAN, J. P. (and GRIGNON, L. D.)	A Visual Light-Valve Checking De- vice A 200-Mil Push-Pull Film Recording System	5 (May)	283
CRABTREE, J. I. (and EATON, G. T., and MUEHLER, L. E.)	A Review of Hypo Testing Methods	3 (Mar.)	127
DAVIS, A. R.	A Review of Hypo Testing Methods	1 (Jan.)	34
	New Lightweight Recording Equip- ment Serves in the War Effort	6 (June)	327
DUNN, L. G.	The New Acme-Dunn Optical Printer	4 (Apr.)	204
EATON, G. T. (and CRABTREE, J. I., and MUEHLER, L. E.)	A Review of Hypo Testing Methods	1 (Jan.)	34
FRIEDMAN, J. S.	Monopack Processes	5 (May)	271
GOLDBERG, H. E. (and IVES, C. E., and KUNZ, C. J.)	Improvement in Illumination Effi- ciency of Motion Picture Printers	5 (May)	294
GOLDNER, O.	The Work of the Training Film Branch, Photographic Division, Bureau of Aeronautics, U. S. Navy —An Overview	2 (Feb.)	71
GREGORY, C. L.	Resurrection of Early Motion Pictures	3 (Mar.)	159
GRIFFIN, H.	The Fifty-Fourth Semi-Annual Meet- ing of the Society	4 (Apr.)	199
GRIGNON, L. D. (and CORCORAN, J. P.)	A 200-Mil Push-Pull Film Recording System	3 (Mar.)	127
HILLMAN, W. P.	The New du Pont Photo Products Control Laboratory	5 (May)	287
HOLCOMB, A. L.	Motor Systems for Motion Picture Production	1 (Jan.)	9

<i>Author</i>		<i>No.</i>	<i>Page</i>
HYNDMAN, D. E.	Report on Engineering of the Society of Motion Picture Engineers	1 (Jan.)	1
	War Standards for Motion Picture Equipment and Processes	4 (Apr.)	211
IVES, C. E.	Improvement in Illumination Efficiency of Motion Picture Printers	5 (May)	294
(and GOLDBERG, H. E., and KUNZ, C. J.)			
(and KUNZ, C. J.)	The Flat Spiral Reel for Processing 50-Ft Lengths of Film	6 (June)	349
KELLOGG, E. W.	Character of Waves Produced by Explosions	1 (Jan.)	58
KUNZ, C. J.	Improvement in Illumination Efficiency of Motion Picture Printers	5 (May)	294
(and GOLDBERG, H. E., and IVES, C. E.)			
(and IVES, C. E.)	The Flat Spiral Reel for Processing 50-Ft Lengths of Film	6 (June)	349
LEWIS, R. B.	Production Planning for Navy Training Films	2 (Feb.)	78
LINDSTROM, C. A.	Agricultural Motion Pictures and the War	3 (Mar.)	177
LIVADARY, J. P.	Evolution of Scoring Facilities at Columbia Pictures	6 (June)	361
(and RETTINGER, M.)			
McGEE, W. R.	Cinematography Goes to War	2 (Feb.)	102
MEES, C. E. K.	Direct Processes for Making Photographic Prints in Color	4 (Apr.)	230
MOUNCE, E. B.	Acoustic Considerations in the Construction of Vocal Studios	6 (June)	372
(and PORTMAN, C., and RETTINGER, M.)	The Vocal Room and Pre-Scoring Operations at RKO Radio Pictures	6 (June)	375
MUEHLER, L. E.	A Review of Hypo Testing Methods	1 (Jan.)	34
(and CRABTREE, J. I., and EATON, G. T.)			
MURPHY, P.	Like This	2 (Feb.)	100
NATER, C.	Walt Disney Studio—A War Plant	3 (Mar.)	170
NELL, E., JR.	The Training Film Program in Action—A Case History	2 (Feb.)	93
(and CARR, H. E., and SARGENT, T.)			
NORTH, E.	The Secondary or Psychological Phase of Training Films	2 (Feb.)	117
PORTMAN, C.	Acoustic Considerations in the Construction of Vocal Studios	6 (June)	372
(and MOUNCE, E. B., and RETTINGER, M.)	The Vocal Room and Pre-Scoring Operations at RKO Radio Pictures	6 (June)	375
RETTINGER, M.	Evolution of Scoring Facilities at Columbia Pictures	6 (June)	361
(and LIVADARY, J. P.)			
(and MOUNCE, E. B. and PORTMAN, C.)	Acoustic Considerations in the Construction of Vocal Studios	6 (June)	372

<i>Author</i>		<i>No.</i>	<i>Page</i>
	The Vocal Room and Pre-Scoring Operations at RKO Radio Pictures	6 (June)	375
RYDER, L. L.	New Scoring Stage Shell and Vocal Studio Design	6 (June)	379
SARGENT, T. (and CARR, H. E., and NELL, E., JR.)	The Training Film Program in Ac- tion—A Case History	2 (Feb.)	93
SLYFIELD, C. O.	Improvements in Disney Scoring Stage	6 (June)	367
TWINING, S. J. (and ZEFF, P.)	A Simplified Variable-Density Sound Negative Developer	5 (May)	315
WALLS, H. L.	Motion Picture Incunabula in The Library of Congress	3 (Mar.)	155
WOODWARD, C. H.	The Motion Picture Program of the Industrial Incentive Division, U. S. Navy	2 (Feb.)	113
ZEFF, P. (and TWINING, S. J.)	A Simplified Variable-Density Sound Negative Developer	5 (May)	315

CLASSIFIED INDEX, VOLUME 42

JANUARY TO JUNE, 1944

Academy of Motion Picture Arts and Sciences (See *Research Council*)

Acoustics

Acoustic Considerations in the Construction of Vocal Studios, E. B. Mounce, C. Portman, and M. Rettinger, No. 6 (June), p. 372.

Apparatus

(See also *Instruments*)

The New Acme-Dunn Optical Printer, L. G. Dunn, No. 4 (Apr.), p. 204.

New Lightweight Recording Equipment Serves in the War Effort, A. R. Davis, No. 6 (June), p. 327.

The Flat Spiral Reel for Processing 50-Ft Lengths of Film, C. E. Ives and C. J. Kunz, No. 6 (June), p. 349.

Army, U. S.

Cinematography Goes to War, W. R. McGee, No. 2 (Feb.), p. 102.

The Secondary or Psychological Phase of Training Films, E. North, No. 2 (Feb.), p. 117.

Atlantic Coast Section (See *SMPE Activities and Announcements*)

Cameras

Cinematography Goes to War, W. R. McGee, No. 2 (Feb.), p. 102.

Cinematography

Cinematography Goes to War, W. R. McGee, No. 2 (Feb.), p. 102.

Coast Guard, U. S. (See *Navy, U. S.*)

Color

Direct Processes for Making Photographic Prints in Color, C. E. K. Mees, No. 4 (Apr.), p. 230.

Monopack Processes, J. S. Friedman, No. 5 (May), p. 271.

Committee Activities and Reports

Report on Engineering of the Society of Motion Picture Engineers, D. E. Hyndman, No. 1 (Jan.), p. 1.

Personnel of SMPE Committees, No. 4 (Apr.), p. 242.

Constitution and By-Laws (See *SMPE Activities and Announcements*)

Current Literature

No. 3 (Mar.), p. 196; No. 4 (Apr.) p. 267; No. 6 (June), p. 384.

Developing (See *Processing*)

Drive Systems (See *Motor Drive Systems*)

Educational Motion Pictures

Agricultural Motion Pictures and the War, C. A. Lindstrom, No. 3 (Mar.), p. 177.

Engineering Vice-President, SMPE

Report on Engineering of the Society of Motion Picture Engineers, D. E. Hyndman, No. 1 (Jan.), p. 1.

War Standards for Motion Picture Equipment and Processes, D. E. Hyndman, No. 4 (Apr.), p. 211.

Explosion Waves (See *Sound Waves*)

General

Wartime Cataloging of Motion Picture Film, J. G. Bradley, No. 3 (Mar.), p. 145.

Motion Picture Incunabula in The Library of Congress, H. L. Walls, No. 3 (Mar.), p. 155.

Resurrection of Early Motion Pictures, C. L. Gregory, No. 3 (Mar.), p. 159.

Historical

Wartime Cataloging of Motion Picture Film, J. G. Bradley, No. 3 (Mar.), p. 145.

Motion Picture Incunabula in The Library of Congress, H. L. Walls, No. 3 (Mar.), p. 155.

Resurrection of Early Motion Pictures, C. L. Gregory, No. 3 (Mar.), p. 159.

Illumination

Improvement in Illumination Efficiency of Motion Picture Printers, C. J. Kunz, H. E. Goldberg, and C. E. Ives, No. 5 (May), p. 294

Instruments

(See also *Apparatus*)

A Visual Light-Valve Checking Device, J. P. Corcoran, No. 5 (May), p. 283.

Journal Award (See *SMPE Activities and Announcements*)

Laboratory Practice

A Review of Hypo Testing Methods, J. I. Crabtree, G. T. Eaton, and L. E. Muehler, No. 1 (Jan.), p. 34.

The New du Pont Photo Products Control Laboratory, W. P. Hillman, No. 5 (May), p. 287.

The Flat Spiral Reel for Processing 50-Ft Lengths of Film, C. E. Ives and C. J. Kunz, No. 6 (June), p. 349.

Light Valves

A Visual Light-Valve Checking Device, J. P. Corcoran, No. 5 (May), p. 283.

Motion Picture Photography (See *Cinematography*)

Motor Drive Systems

Motor Systems for Motion Picture Production, A. L. Holcomb, No. 1 (Jan.), p. 9.

Motor Speed Controls (See *Motor Drive Systems*)**Navy, U. S.**

The Work of the Training Film Branch, Photographic Division, Bureau of Aeronautics, U. S. Navy—An Overview, O. Goldner, No. 2 (Feb.), p. 71.

Production Planning for Navy Training Films, R. B. Lewis, No. 2 (Feb.), p. 78.

Making Films That Teach, R. Bell, No. 2 (Feb.), p. 85.

The Training Film Program in Action—A Case History, H. E. Carr, E. Nell, Jr., and T. Sargent, No. 2 (Feb.), p. 93.

Like This, P. Murphy, No. 2 (Feb.), p. 100.

The Motion Picture Program of the Industrial Incentive Division, U. S. Navy, C. H. Woodward, No. 2 (Feb.), p. 113.

Obituary

J. N. Gelman, No. 6 (June), p. 386.

Optical Printing (See *Printing*)**Optics**

Improvement in Illumination Efficiency of Motion Picture Printers, C. J. Kunz, H. E. Goldberg and C. E. Ives, No. 5 (May), p. 294.

Pacific Coast Section (See *SMPE Activities and Announcements*)**President, SMPE**

The Fifty-Fourth Semi-Annual Meeting of the Society, H. Griffin, No. 4 (Apr.), p. 199.

Printing

The New Acme-Dunn Optical Printer, L. G. Dunn, No. 4 (Apr.), p. 204.

Improvement in Illumination Efficiency of Motion Picture Printers, C. J. Kunz, H. E. Goldberg, and C. E. Ives, No. 5 (May), p. 294.

Processing

A Review of Hypo Testing Methods, J. I. Crabtree, G. T. Eaton, and L. E. Muehler, No. 1 (Jan.), p. 34.

Direct Processes for Making Photographic Prints in Color, C. E. K. Mees, No. 4 (Apr.), p. 230.

Monopack Processes, J. S. Friedman, No. 5 (May), p. 271.

The New du Pont Photo Products Control Laboratory, W. P. Hillman, No. 5 (May), p. 287.

A Simplified Variable-Density Sound Negative Developer, P. Zeff and S. J. Twining, No. 5 (May), p. 315.

The Flat Spiral Reel for Processing 50-Ft Lengths of Film, C. E. Ives and C. J. Kunz, No. 6 (June), p. 349.

Production

Production Planning for Navy Training Films, R. B. Lewis, No. 2 (Feb.), p. 78.

Walt Disney Studio—A War Plant, C. Nater, No. 3 (Mar.), p. 170.

Progress Medal Award (See *SMPE Activities and Announcements*)

Recording (See *Sound Recording*)

Research Council, Academy of Motion Picture Arts and Sciences

Report of Basic Sound Committee on Pre- and Post-Equalization for Studio Use, No. 3 (Mar.), p. 187.

SMPE Activities and Announcements

Addition of F. H. Richardson to Honor Roll, No. 6 (June), p. 385.

American Standards for the JOURNAL, No. 6 (June), p. 385.

Atlantic Coast Section:

Meeting, Jan. 19—No. 3 (Mar.), p. 198; Meeting, Feb. 23—No. 4 (Apr.), p. 268; Meeting, Mar. 22—No. 5 (May), p. 325.

Constitution and By-Laws, No. 4 (Apr.), p. 248.

Cumulative Index, 1936-1940, No. 6 (June), p. 385.

Fifty-Fourth Semi-Annual Meeting of the Society, H. Griffin, No. 4 (Apr.), p. 199.

Fifty-Fifth Semi-Annual Technical Conference:

Committees and Tentative Program, No. 1 (Jan.), p. 68; No. 2 (Feb.), p. 123; No. 3 (Mar.), p. 193; No. 4 (Apr.), p. 262.

Titles and Authors of Papers, No. 4 (Apr.), p. 262.

Journal Award and Progress Medal Award Regulations, No. 4 (Apr.), p. 259.

Officers and Governors, No. 4 (Apr.), p. 239.

Pacific Coast Section:

Meeting, Jan. 25—No. 3 (Mar.), p. 198; Meetings, Feb. 15 and 29—No. 4 (Apr.), p. 268; Meeting, May 2—No. 6 (June), p. 385.

Personnel of SMPE Committees, No. 4 (Apr.), p. 242.

Report on Engineering of the Society of Motion Picture Engineers, D. E. Hyndman, No. 1 (Jan.), p. 1.

Representatives to Other Organizations, No. 4 (Apr.), p. 246.

Scoring

Evolution of Scoring Facilities at Columbia Pictures, J. P. Livadary and M. Rettinger, No. 6 (June), p. 361.

Improvements in Disney Scoring Stage, C. O. Slyfield, No. 6 (June), p. 367.

Acoustic Considerations in the Construction of Vocal Studios, E. B. Mounce, C. Portman, and M. Rettinger, No. 6 (June), p. 372.

The Vocal Room and Pre-Scoring Operations at RKO Radio Pictures, E. B. Mounce, C. Portman, and M. Rettinger, No. 6 (June), p. 375.

New Scoring Stage Shell and Vocal Studio Design, L. L. Ryder, No. 6 (June), p. 379.

Sixteen-Mm Motion Pictures (See *Educational Motion Pictures, Training Films, Army, U. S., Navy, U. S.*)

Sound Recording

A 200-Mil Push-Pull Film Recording System, L. D. Grignon and J. P. Corcoran, No. 3 (Mar.), p. 127.

Report of Basic Sound Committee on Pre- and Post-Equalization for Studio Use, No. 3 (Mar.), p. 187.

Notes on Operating Experience Using the Direct Positive Push-Pull Method of Recording, A. C. Blaney, No. 5 (May), p. 279.

A Visual Light-Valve Checking Device, J. P. Corcoran, No. 5 (May), p. 283.

A Simplified Variable-Density Sound Negative Developer, P. Zeff and S. J. Twining, No. 5 (May), p. 315.

New Lightweight Recording Equipment Serves in the War Effort, A. R. Davis, No. 6 (June), p. 327.

Evolution of Scoring Facilities at Columbia Pictures, J. P. Livadary and M. Rettinger, No. 6 (June), p. 361.

Improvements in Disney Scoring Stage, C. O. Slyfield, No. 6 (June), p. 367.

Acoustic Considerations in the Construction of Vocal Studios, E. B. Mounce, C. Portman, and M. Rettinger, No. 6 (June), p. 372.

The Vocal Room and Pre-Scoring Operations at RKO Radio Pictures, E. B. Mounce, C. Portman, and M. Rettinger, No. 6 (June), p. 375.

New Scoring Stage Shell and Vocal Studio Design, L. L. Ryder, No. 6 (June), p. 379.

Sound Waves

Character of Waves Produced by Explosions, E. W. Kellogg, No. 1 (Jan.), p. 58.

Standards

Report on Engineering of the Society of Motion Picture Engineers, D. E. Hyndman, No. 1 (Jan.), p. 1.

War Standards for Motion Picture Equipment and Processes, D. E. Hyndman, No. 4 (Apr.), p. 211.

Personnel of ASA Sectional Committee on Motion Pictures, Z22, No. 4 (Apr.), p. 247.

Synchronous Motors (See *Motor Drive Systems*)

Teaching Films (See *Educational Motion Pictures, Army, U. S., and Navy, U. S.*)

Training Films

(See also *Army, U. S., Navy, U. S.*)

Walt Disney Studio—A War Plant, C. Nater, No. 3 (Mar.), p. 170.

Agricultural Motion Pictures and the War, C. A. Lindstrom, No. 3 (Mar.), p. 177.

Vocal Studios

Acoustic Considerations in the Construction of Vocal Studios, E. B. Mounce, C. Portman, and M. Rettinger, No. 6 (June), p. 372.

The Vocal Room and Pre-Scoring Operations at RKO Radio Pictures, E. B. Mounce, C. Portman, and M. Rettinger, No. 6 (June), p. 375.

New Scoring Stage Shell and Vocal Studio Design, L. L. Ryder, No. 6 (June), p. 379.

Washing Photographic Materials

(See also *Processing*)

A Review of Hypo Testing Methods, J. I. Crabtree, G. T. Eaton, and L. E. Muehler, No. 1 (Jan.), p. 34.

MEMBERS OF THE SOCIETY
LOST IN THE SERVICE OF
THEIR COUNTRY

FRANKLIN C. GILBERT

ISRAEL H. TILLES



VALTERS & SONS
BOUND
SEP 9 1944

