

L.R.1.

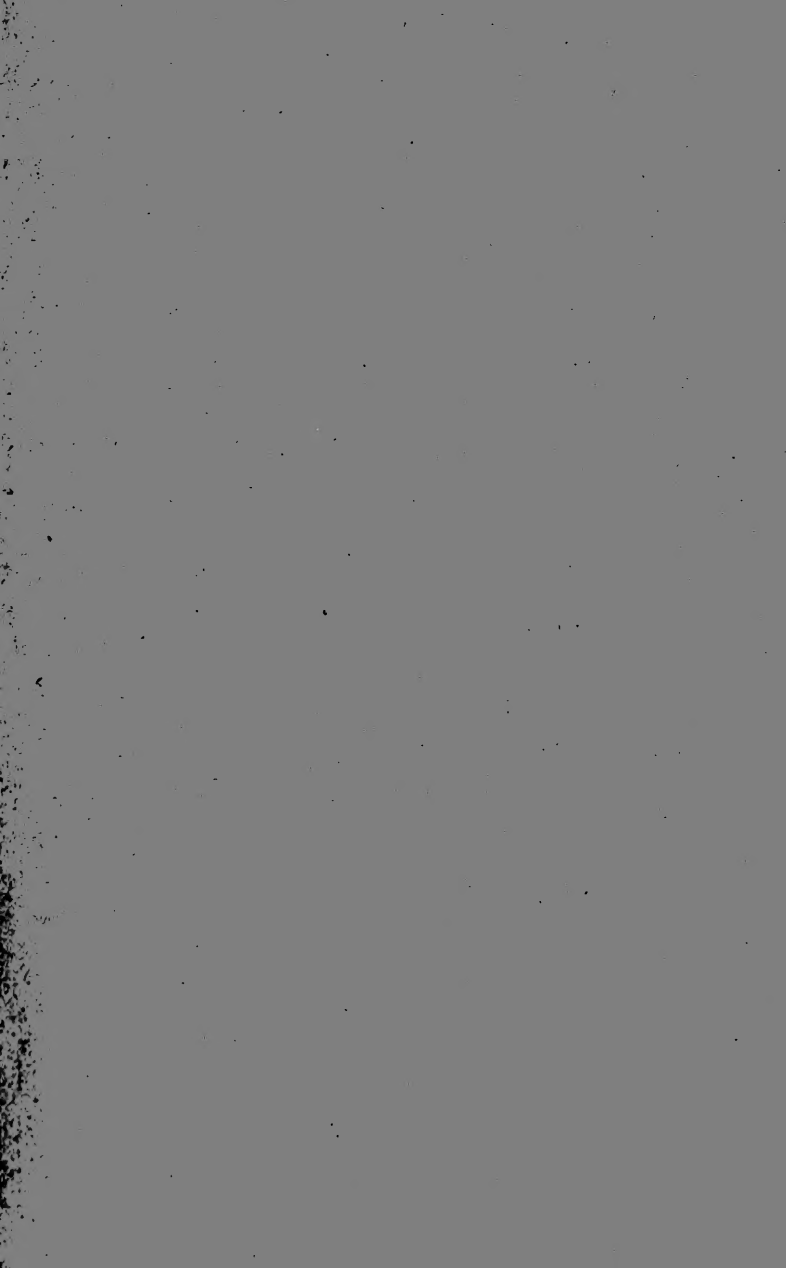





Labran, Room 5, 1

1755

Published the Last Day of every Month,

[PRICE 2s. 6d.]

THE
PHILOSOPHICAL MAGAZINE:

COMPREHENDING

THE VARIOUS BRANCHES OF SCIENCE,

THE LIBERAL AND FINE ARTS,

AGRICULTURE, MANUFACTURES,

AND

COMMERCE.

NUMBER CXXXV.

For JULY 1809.

CONTAINING THE FOLLOWING ENGRAVINGS:

- 1, 2. Two Plates to illustrate M. HAUY's Crystallography.
 3. Apparatus to illustrate Mr. DAVY's Bakerian Lecture.
-

BY ALEXANDER TILLOCH,

M.R.I.A. F.S.A. EDIN. AND PERTH. &C.

LONDON:

PRINTED BY RICHARD TAYLOR AND CO., SHOE LANE:

And sold by RICHARDSONS; CADELL and DAVIES; LONGMAN,
HURST, REES, and ORME; VERNOR, HOOD, and SHARPE;
MURRAY; HIGHLEY; SHERWOOD and Co.; HARDING; London:
BELL and BRADFUTE, and CONSTABLE and Co. Edinburgh:
BRASH and REID, and D. NIVEN, Glasgow: and GILBERT and
HODGES, Dublin.

Vol. XXVI. is illustrated with a Quarto Plate of M. LE ROY's Chronometer—Mr. SYLVESTER's improved Air-Pump—A large Plate relating to LE ROY's Chronometer—An Octavo Plate on the same Subject—The Irish Canal Track-Boat—Mr. STEEVENS's Autocratic Cock for large Reservoirs—Mr. WOOLF's improved Piston for Steam-Engines—Another Plate relating to the same Subject.

Vol. XXVII. is illustrated with a Quarto Plate of Mr. STEEVENS's Compound Gasometer—Mr. MASERES's Fire-Escape—Mr. WALKER's new Optical Instrument called the *Phantasmascope*—Mr. SNODGRASS's Method of Heating Buildings and Apartments by Means of Steam—Mr. TROTTER's Machinery for Curvilinear Sawing, and Mr. HARDIE's Improved Book-binder's Cutting Press—Mr. GEORGE FIELD's Stove for Heating Rooms, and Drying various Articles—Figures illustrating the Manner of using Mr. WALKER's Transit Instrument—Dr. WOLLASTON's Camera Lucida for drawing from Nature in Perspective.

Vol. XXVIII. is illustrated with Mr. KATER's Hygrometer—RAMSDEN's Optigraph improved by Mr. JONES—Figures to illustrate Mr. EVANS's Paper on Goniometry—Apparatus employed by Mr. DAVY in his new Galvanic Experiments—DESCROIZILLES' Alkali-meter; and Figures to illustrate C. A. PRIEUR's Experiments on the Decomposition of Light—A Quarto Plate, containing a Skeleton of the Indian Elephant—An Octavo Plate on the same Subject—A Quarto Plate of Tables relating to Musical Temperature, by Mr. FAREY—Anatomical Figures relating to the Elephant.

Vol. XXIX. is embellished with a Portrait of the late Dr. DARWIN; from an original Picture in the Possession of Dr. THORNTON—A New Micrometer, invented by Mr. BREWSTER—A Representation of the Comet now visible.—Mr. FIELD's Plan for Building Towns and Villages composed of Circular Buildings—Mr. PEPYS's New Eudiometer—A Quarto Plate of the Apparatus employed by Mess. ALLEN and PEPYS in their Experiments on Carbonic Acid—A fourth Plate to illustrate M. CUVIER's Paper on Elephants—Lieut. Col. CRICHTON's Bed for the easy Conveyance of Sick and Wounded Soldiers: engraved by PORTER—And Capt. PASLEY's Improved Telegraph: engraved by PORTER.

Vol. XXX. Sir H. C. ENGLEFIELD's Mountain Barometer, engraved by LOWRY—A Plate to illustrate M. CUVIER's Paper on Elephants—Another Plate on the same Subject.—1 and 2. Two Plates to illustrate M. CUVIER's Paper on Elephants, engraved by PORTER.—3. Figures to illustrate Mr. HERSCHEL's Paper on Coloured Rings.—A Skeleton of the American Mammoth, engraved by PORTER.—A Portrait of M. CARNOT—The Oil-mill of Bangalore.

Vol. XXXI. Mr. DAVY's new Eudiometer.—Geological Sections of Strata, in Matlock, Derbyshire, by Mr. WHITEHURST and Mr. FAREY.—Illustration of the Chinese Method of propagating Fruit Trees by Abscission—And Mr. BROAD's Gauge for measuring Timber.—Illustration of Mrs. D'OYLEY's Method of breeding Poultry; Mr. DREW's Balance Level for laying-out Land for Irrigation; and an Experiment in Optics.—Mr. E. TURRELL's Construction of Chemical Muffles.—Mr. GILPIN's Machine for raising Coals and Ores.—WILSON's Secure Boat, or Life Boat; and BOSWELL's improved Capstan: engraved by PORTER.—PEPYS's Apparatus for Decomposing the Alkalis under Naphtha: engraved by LOWRY.—ATKINS's improved Hydrometer for weighing Solids and Fluids.

Published the Last Day of every Month,

[PRICE 2s. 6d.]

THE
PHILOSOPHICAL MAGAZINE:

COMPREHENDING

THE VARIOUS BRANCHES OF SCIENCE,

THE LIBERAL AND FINE ARTS,

AGRICULTURE, MANUFACTURES,

AND

COMMERCE.

NUMBER CXXXVI.

For AUGUST 1809.

CONTAINING THE FOLLOWING ENGRAVINGS:

- 1, 2. A Quarto and an Octavo Plate descriptive of Mr. TROUGHTON'S new dividing Instrument.
-

BY ALEXANDER TILLOCH,

M.R.I.A. F.R.S.A. EDIN. AND PERTH. &c.

LONDON:

PRINTED BY RICHARD TAYLOR AND CO., SHOE LANE:

And sold by RICHARDSONS; CADELL and DAVIES; LONGMAN, HURST, REES, and ORME; VERNOR, HOOD, and SHARPE; MURRAY; HIGHLEY; SHERWOOD and Co.; HARDING; London: BELL and BRADFUTE, and CONSTABLE and Co. Edinburgh: BRASH and REID, and D. NIVEN, Glasgow: and GILBERT and HODGES, Dublin.

Vol. XXIX. is embellished with a Portrait of the late Dr. DARWIN; from an original Picture in the Possession of Dr. THORNTON—A New Micrometer, invented by Mr. BREWSTER—A Representation of the Comet now visible.—Mr. FIELD's Plan for Building Towns and Villages composed of Circular Buildings—Mr. PEPYS's New Eudiometer—A Quarto Plate of the Apparatus employed by Mess. ALLEN and PEPYS in their Experiments on Carbonic Acid—A fourth Plate to illustrate M. CUVIER's Paper on Elephants—Lieut. Col. CRICHTON's Bed for the easy Conveyance of Sick and Wounded Soldiers: engraved by PORTER—And Capt. PASLEY's Improved Telegraph: engraved by PORTER.

Vol. XXX. Sir H. C. ENGLEFIELD's Mountain Barometer, engraved by LOWRY—A Plate to illustrate M. CUVIER's Paper on Elephants—Another Plate on the same Subject.—1 and 2. Two Plates to illustrate M. CUVIER's Paper on Elephants, engraved by PORTER.—3. Figures to illustrate Mr. HERSCHEL's Paper on Coloured Rings.—A Skeleton of the American Mammoth, engraved by PORTER.—A Portrait of M. CARNOT—The Oil-mill of Bangalore.

Vol. XXXI. Mr. DAVY's new Eudiometer.—Geological Sections of Strata, in Matlock, Derbyshire, by Mr. WHITEHURST and Mr. FAREY.—Illustration of the Chinese Method of propagating Fruit Trees by Abscission—And Mr. BROAD's Gauge for measuring Timber.—Illustration of Mrs. D'OYLEY's Method of breeding Poultry; Mr. DREW's Balance Level for laying-out Land for Irrigation; and an Experiment in Optics.—Mr. E. TURRELL's Construction of Chemical Muffles.—Mr. GILPIN's Machine for raising Coals and Ores.—WILSON's Secure Boat, or Life Boat; and BOSWELL's improved Capstan: engraved by PORTER.—PEPYS's Apparatus for Decomposing the Alkalis under Naphtha: engraved by LOWRY.—ATKINS's improved Hydrometer for weighing Solids and Fluids.

Vol. XXXII. Mr. CLEALL's Machine for thrashing Hemp; and Mr. BOND's Machine for breaking Hemp.—Mr. WARD's Compensation Pendulum.—Mr. GROOMBRIDGE's Diagram of the Motion of the Planet Vesta.—A Portrait of Sir H. C. ENGLEFIELD.—Mr. CHARLES LE CAAN's Tram-Plates—and Mr. COLLIER's Ship Stove.—Apparatus employed by Messrs. ALLEN and PEPYS in their Experiments on Respiration.—Mr. HENRY's Apparatus for Decomposing Compound Inflammable Gases.—Apparatus employed in the Royal Institution for the Decomposition of Potash by Iron.—BELL's Method of saving Shipwrecked Mariners.

Vol. XXXIII. Mr. JAMES ELMES's Portable Bridge.—Mr. KNIGHT's new Method of training Fruit Trees.—Mr. HERSCHEL's Figures of the Comet of 1807.—Two Plates to illustrate Dr. WILLIAM RICHARDSON's Paper on the Basaltic Surface of the Counties of Derry and Antrim: viz. A View of PORTMOON.—A View of PLESKIN, on the N. W. side of Bengore Promontory.—Mr. CLEGG's Apparatus for making Carbonated Hydrogen Gas from Pit-Coal.—Mr. RICHARDSON's Machine for raising large Stones out of the Earth;—and Mr. GOUGH's new Hygrometer.—PILTON's Light Fence for Inclosures, which becomes invisible at a short Distance.—Proposed Improvements in Telescopes, by M. BURKHARDT and by Dr. BREWSTER; and M. BOULLAY's Apparatus for Phosphoric Ether.—Major LE HARDY's Telegraph.—Capt. BOLTON's improved Jury Mast; and Capt. BALL's Method of Fishing Anchors.—Plan and Section of the Thames Archway.—Plan of Stonyhurst Scientific Establishment.—Mr. TAD's Method of causing a Door to open over a Carpet;—and Mr. BARLOW's Wrench for Screw Nuts of any Size.

Vol. XXXIV. Two Plates to illustrate M. HAUY's Crystallography.—Apparatus to illustrate Mr. DAVY's Bakerian Lecture.

Published the Last Day of every Month,

[PRICE 2s. 6d.]

THE
PHILOSOPHICAL MAGAZINE:

COMPREHENDING
THE VARIOUS BRANCHES OF SCIENCE,
THE LIBERAL AND FINE ARTS,
AGRICULTURE, MANUFACTURES,
AND
COMMERCE.

NUMBER CXXXVIII.

For OCTOBER 1809.

CONTAINING THE FOLLOWING ENGRAVINGS:

1. A Quarto Plate to illustrate Mr. KIRWAN's new Anemometer; engraved by PORTER.
2. An Octavo Plate to illustrate M. HAUY's Crystallography; engraved by LOWRY.

BY ALEXANDER TILLOCH,

M.R.I.A. P.S.A. EDIN. AND PERTH. & C.

LONDON:

PRINTED BY RICHARD TAYLOR AND CO., SHOE LANE:
And sold by RICHARDSONS; CADELL and DAVIES; LONGMAN,
HURST, REES, and ORME; VERNOR, HOOD, and SHARPE;
MURRAY; HIGHLEY; SHERWOOD and Co.; HARDING; London:
BELL and BRADFUTE, and CONSTABLE and Co. Edinburgh:
BRASH and REID, and D. NIVEN, Glasgow: and GILBERT and
HODGES, Dublin.

ENGRAVINGS.

Vol. XXIV. is embellished with a Plate of Figures to illustrate Mr. DALTON'S Theory of the Absorption of Gases by Liquids—On the same;—also a Refrigeratory for Distillation, acting on the Principle of the Syphon—The Effects produced by Mr. EZ. WALKER'S newly invented Cometaryum—A Quarto Plate illustrative of Experiments by Sir JAMES HALL, Bart., on the Effects of Compression in modifying the Action of Heat—Mr. STEEVENS'S improved Gasometer, for Purposes where uniform Pressure is essential—A Plate illustrating Mr. WALKER'S Paper on the apparent Magnitude of the horizontal Moon—A Quarto Plate illustrative of Sir JAMES HALL'S Experiments on the Effects of Heat modified by Compression—A Portrait of Mr. AGEERT: engraved by Mr. E. Mackenzie—A Quarto Plate of Natural History, viz. the Fishes *Bremobolus Mutisii*, *Astrobolus Grixalvii*, and *Pimelodus Cyclopus*; and a South American Monkey, the *Simia leonina*: engraved by Lowry.

Vol. XXV. contains an Octavo Plate illustrative of Experiments by Sir JAMES HALL on the Effects of Compression in modifying the Action of Heat—A Quarto Plate on the same Subject—A Quarto Plate to illustrate Sir JAMES HALL'S Paper on the Effects of Heat modified by Compression—Mr. SALMON'S improved Geometrical Quadrant, Level, and Calculator, for ascertaining inaccessible Distances on Land or at Sea.—M. MONTGOLFIER'S new Calorimeter, for determining the comparative Quantities of Caloric evolved by the Combustion of different Kinds of Fuel—Mr. GILBERT GILPIN'S improved Crane with Flexible Chains—Mr. HERBERT'S book-case Bolt, and Mr. LE CAAN'S Check for Carriage Wheels on Rail-Roads—SALMON'S Improvement on Canal Locks.—Figures to illustrate M. GROTHIUS'S Memoir on the Decomposition of Water by Galvanism—A Bust in Silex, found coated over with Calcedony.

Vol. XXVI. is illustrated with a Quarto Plate of M. LE ROY'S Chronometer—Mr. SYLVESTER'S improved Air-Pump—A large Plate relating to LE ROY'S Chronometer—An Octavo Plate on the same Subject—The Irish Canal Track-Boat—Mr. STEEVENS'S Autocratic Cock for large Reservoirs—Mr. WOOLF'S improved Piston for Steam-Engines—Another Plate relating to the same Subject.

Vol. XXVII. is illustrated with a Quarto Plate of Mr. STEEVENS'S Compound Gasometer—Mr. MASEPES'S Fire Escape—Mr. WALKER'S new Optical Instrument called the *Phantasmoscope*—Mr. SNODGRASS'S Method of Heating Buildings and Apartments by Means of Steam—Mr. TROTTER'S Machinery for Curvilinear Sawing, and Mr. HARDIE'S Improved Book-binder's Cutting Press—Mr. GEORGE FIELD'S Stove for Heating Rooms, and Drying various Articles—Figures illustrating the Manner of using Mr. WALKER'S Transit Instrument—Dr. WOLLASTON'S Camera Lucida for drawing from Nature in Perspective.

Vol. XXVIII. is illustrated with Mr. KATER'S Hygrometer—RAMSDEN'S Optigraph improved by Mr. JONES.—Figures to illustrate Mr. EVANS'S Paper on Conicometry—Apparatus employed by Mr. DAVY in his new Galvanic Experiments—DESCROIZILLIS' Alkali-meter; and Figures to illustrate C. A. BRIEUR'S Experiments on the Decomposition of Light—A Quarto Plate, containing a Skeleton of the Indian Elephant—An Octavo Plate on the same Subject—A Quarto Plate of Tables relating to Musical Temperatures, by Mr. FARNEY—Anatomical Figures relating to the Elephant.

Vol. XXIX. is embellished with a Portrait of the late Dr. DARWIN; from an original Picture in the Possession of Dr. THOANTON—A New Micrometer, invented by Mr. BREWSTER—A Representation of the Comet now visible.—Mr. FIELD'S Plan for Building Towns and Villages com-

Published the Last Day of every Month,

[PRICE 2s. 6d.]

THE
PHILOSOPHICAL MAGAZINE:

COMPREHENDING

THE VARIOUS BRANCHES OF SCIENCE,
THE LIBERAL AND FINE ARTS,
AGRICULTURE, MANUFACTURES,
AND
COMMERCE.

NUMBER CXXXIX.

For NOVEMBER 1809.

CONTAINING THE FOLLOWING ENGRAVINGS:

1. A Plate to illustrate Messrs. ALLEN and PEPYS' new Experiments on Respiration. Engraved by PORTER.
 2. A Plate to illustrate M. HAUY's Crystallography.
-

BY ALEXANDER TILLOCH,

M.R.I.A. F.S.A. EDIN. AND PERTH. &c.

LONDON:

PRINTED BY RICHARD TAYLOR AND CO., SHOE LANE:
And sold by RICHARDSONS; CADELL and DAVIES; LONGMAN,
HURST, REES, and ORME; VERNOR, HOOD, and SHARPE;
MURRAY; HIGHLEY; SHERWOOD and Co.; HARDING; London:
BELL and BRADPUTE, and CONSTABLE and Co. Edinburgh:
BRASH and REID, and D. NIVEN, Glasgow: and GILBERT and
HODGES, Dublin.

Vol. XXIV. is embellished with a Plate of Figures to illustrate Mr. DALTON's Theory of the Absorption of Gases by Liquids—On the same;—also a Refrigeratory for Distillation, acting on the Principle of the Syphon—The Effects produced by Mr. EZ. WALKER's newly invented Cometaryium—A Quarto Plate illustrative of Experiments by Sir JAMES HALL, Bart., on the Effects of Compression in modifying the Action of Heat—Mr. STEEVENS's improved Gasometer, for Purposes where uniform Pressure is essential—A Plate illustrating Mr. WALKER's Paper on the apparent Magnitude of the horizontal Moon—A Quarto Plate illustrative of Sir JAMES HALL's Experiments on the Effects of Heat modified by Compression—A Portrait of Mr. AUBERT: engraved by Mr. E. Mackenzie—A Quarto Plate of Natural History, viz. the Fishes *Eremophilus Mutisii*, *Astroblepus Grixalvii*, and *Pimelodus Cyclopus*; and a South American Monkey, the *Simia leonina*: engraved by Lowry.

Vol. XXV. contains an Octavo Plate illustrative of Experiments by Sir JAMES HALL on the Effects of Compression in modifying the Action of Heat—A Quarto Plate on the same Subject—A Quarto Plate to illustrate Sir JAMES HALL's Paper on the Effects of Heat modified by Compression—Mr. SALMON's improved Geometrical Quadrant, Level, and Calculator, for ascertaining inaccessible Distances on Land or at Sea.—M. MONTGOLFIER's new Calorimeter, for determining the comparative Quantities of Caloric evolved by the Combustion of different Kinds of Fuel—Mr. GILBERT GILPIN's improved Crane with Flexible Chains—Mr. HERBERT's Book-case Bolt, and Mr. LE CAAN's Check for Carriage Wheels on Rail-Roads—SALMON's Improvement on Canal Locks—Figures to illustrate M. GROTHIUS's Memoir on the Decomposition of Water by Galvanism—A Bust in Silex, found coated over with Calcedony.

Vol. XXVI. is illustrated with a Quarto Plate of M. LE ROY's Chronometer—Mr. SYLVESTER's improved Air-Pump—A large Plate relating to LE ROY's Chronometer—An Octavo Plate on the same Subject—The Irish Canal Track-Boat—Mr. STEEVENS's Autocratic Cock for large Reservoirs—Mr. WOOLF's improved Piston for Steam-Engines—Another Plate relating to the same Subject:

Vol. XXVII. is illustrated with a Quarto Plate of Mr. STEEVENS's Compound Gasometer—Mr. MASERES's Fire-Escape—Mr. WALKER's new Optical Instrument called the *Phantasmoscope*—Mr. SNODGRASS's Method of Heating Buildings and Apartments by Means of Steam—Mr. TROTTER's Machinery for Curvilinear Sawing, and Mr. HARDIE's Improved Book-binder's Cutting Press—Mr. GEORGE FIELD's Stove for Heating Rooms, and Drying various Articles—Figures illustrating the Manner of using Mr. WALKER's Transit Instrument—Dr. WOLLASTON's Camera Lucida for drawing from Nature in Perspective.

Vol. XXVIII. is illustrated with Mr. KATER's Hygrometer—RAMSDEN's Optigraph improved by Mr. JONES—Figures to illustrate Mr. EVANS's Paper on Goniometry—Apparatus employed by Mr. DAVY in his new Galvanic Experiments—DESCROIZILLES' Alkali-meter; and Figures to illustrate C. A. PRIEUR's Experiments on the Decomposition of Light—A Quarto Plate, containing a Skeleton of the Indian Elephant—An Octavo Plate on the same Subject—A Quarto Plate of Tables relating to Musical Temperature, by Mr. FAREY—Anatomical Figures relating to the Elephant.

Vol. XXIX. is embellished with a Portrait of the late Dr. DARWIN; from an original Picture in the Possession of Dr. THORNTON—A New Micrometer, invented by Mr. BREWSTER—A Representation of the Comet now visible.—Mr. FIELD's Plan for Building Towns and Villages composed of Circular Buildings—Mr. PEPYS's New Eudiometer—A Quarto

THE
PHILOSOPHICAL MAGAZINE:

COMPREHENDING
THE VARIOUS BRANCHES OF SCIENCE,
THE LIBERAL AND FINE ARTS,
AGRICULTURE, MANUFACTURES,
AND
COMMERCE.

BY ALEXANDER TILLOCH,
M.R.I.A. F.S.A. EDIN. AND PERTH, &C.

“Nec araneorum sane textus ideo melior quia ex se fila pignunt, nec noster
cillior quia ex alienis libamus ut apes.” JUST. LIPS. *Menit. Polit.* lib. i. cap. 1.

VOL. XXXIV.

For JULY, AUGUST, SEPTEMBER, OCTOBER, NOVEMBER,
and DECEMBER, 1809.

LONDON:

PRINTED BY RICHARD TAYLOR AND CO., SHOE LANE:

And sold by RICHARDSONS; CADELL and DAVIES; LONGMAN, HURST,
REES, and ORME; VERNOR, HOOD, and SHARPE; MURRAY;
HIGHLEY; SHERWOOD and Co.; HARDING; London:
BELL and BRADFUTE, and CONSTABLE and Co.
Edinburgh: BRASH and REID, and NIVEN,
Glasgow: & GILBERT & HODGES, Dublin.

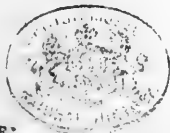

THE

MINERAL INVESTIGATION

REPORT

ON THE

MINERAL RESOURCES OF

THE STATE OF

1914

BY

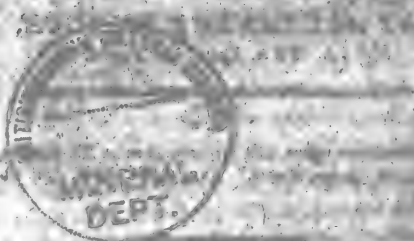

TITLE

MINERAL RESOURCES OF THE STATE OF

U.S. GEOLOGICAL SURVEY
WASHINGTON, D.C.

CONTENTS
OF THE
THIRTY-FOURTH VOLUME.

<i>ON Deal Pendulum Rods</i>	3
<i>The Bakerian Lecture. An Account of some new analytical Researches on the Nature of certain Bodies, particularly the Alkalies, Phosphorus, Sulphur, Carbonaceous Matter, and the Acids hitherto undecomposed; with some general Observations on Chemical Theory</i>	6, 108, 181
<i>An Inquiry into the Terrestrial Phænomena produced by the Action of the Ocean</i>	19, 137
<i>An Account of some Experiments, performed with a View to ascertain the most advantageous Method of constructing a Voltaic Apparatus, for the Purposes of Chemical Research</i>	26
<i>On the Origin and Formation of Roots</i>	31
<i>Analysis of the Mécanique Céleste of M. LA PŁACE. By M. BIOT</i>	36, 202, 252
<i>Account of the Dissection of a Human Fœtus, in which the Circulation of the Blood was carried on without a Heart</i>	43
<i>Geological Observations on the Excavations of Valleys, the supposed Existence of numerous Lakes at former Periods where Valleys now exist, which the Streams flowing through them are said to have broken down, &c., in Reply to Mr. JOHN CARR'S</i>	49
<i>A numerical Table of elective Attractions; with Remarks on the Sequences of double Decompositions</i>	53
Vol. 34. No. 140. Dec. 1809. a	On

CONTENTS.

<i>On Crystallography</i>	64, 96, 210, 289, 349, 455
<i>An Account of a Method of dividing astronomical and other Instruments, by ocular Inspection; in which the usual Tools for graduating are not employed; the whole Operation being so contrived, that no Error can occur but what is chargeable to Vision, when assisted by the best optical Means of viewing and measuring minute Quantities</i>	81, 163
<i>Suggestion for establishing a Telegraphic Intercourse between London and Dublin</i>	124
<i>A concise Abstract of Professor MITCHILL'S Discourses on Mineralogy, the sixth great Section of the Course of Natural History which he delivers in the new Institution at New York</i>	125
<i>Account of the internal Exhibition of the Acetate of Lead in several Diseases</i>	129
<i>On the Use of Fumigations in Army Hospitals</i> ..	132
<i>Meteorological Observations on a Thunder Storm; with some Remarks on Medical Electricity</i>	161
<i>Report made to the Institute on two Memoirs of M. GRATIEN LEPERE, Engineer of the Imperial Roads and Bridges, on natural and artificial Puzzolano. By M. CHAPTAL</i>	178
<i>On the Causes which have operated in the Production of Valleys</i>	190
<i>Further Remarks on Thunder Storms</i>	201
<i>On the Date of the Application of Telescopes to astronomical Instruments; the Time when Astronomers first observed the Stars and Planets in the Day-time by means of these Telescopes; and on the Author of these Discoveries. Translated from the French of M. DE FOUCHY</i>	241
<i>A Description of a new Anemometer</i>	247
<i>Cosmogeny of the Iroquois, or Five Indian Nations of Canada</i>	261
<i>On the Breeding of Fish, and the Natural History of their Generation</i>	268, 324
<i>On</i>	On

CONTENTS.

<i>On the Generation and other obscure Facts in the Natural History of the Common Eel</i>	272
<i>Experiments on the Production of Sounds in Vapours.</i> By M. BIOT	277
<i>Observations on the remarkable Efficacy of Carrots, under a new Mode of Application, in the Cure of Ulcers and Sores</i>	281
<i>On the Ascent of Salmon over the Elevations in the Course of Rivers, called Salmon-Leaps</i>	321
<i>On some Phænomena which take place in the Formation of Saltpetre</i>	334
<i>New analytical Researches on the Nature of certain Bodies, being an Appendix to the Bakerian Lecture for 1808</i>	339, 405
<i>Inquiry whether Nævus Materna, with which Children are sometimes born, should be attributed to the Imagination of the Mother</i>	347
<i>An Examination of the Review which appeared in the XIIIth Number of "The Retrospect," &c., of Doctor HERSCHEL'S Essay on the coloured Rings discovered by Sir ISAAC NEWTON</i>	359
<i>Experiments on Ammonia, and an Account of a new Method of analysing it, by Combustion with Oxygen and other Gases</i>	369, 447
<i>Observations on the Leech-worm</i>	376
<i>On Broom Flax</i>	378
<i>On Respiration</i>	379, 415
<i>Description of certain Inventions for the Improvement of Naval Architecture, for increasing the Comforts of Mariners, and for facilitating Naval Enterprises</i>	387, 426
<i>Description of a Rotative Steam Engine, the Piston of which makes a complete Revolution at a Distance from the revolving Axis</i>	401
<i>Account of certain Colours dug up at Pompeia. Read to the National Institute the 6th of March 1809. By M. CHAPTAL</i>	411
<i>Of the Action of Vegetable Acids on Alcohol, both with and</i>	

CONTENTS.

<i>and without the Intermedium of the Mineral Acids. By M. THENARD. Read at the Institute on the 23d of November 1807</i>	431
<i>On the Combination of Acids with Animal and Vegetable Substances</i>	439
<i>Notices respecting New Books</i>	391, 466
<i>Proceedings of Learned Societies</i>	70, 143, 227, 302, 392,	468
<i>Intelligence and Miscellaneous Articles</i>	77, 155, 237, 314,	394, 470
<i>List of New Patents</i>	79, 238, 319, 398, 471
<i>Meteorological Tables</i>	80, 106, 240, 320, 400, 473

THE
PHILOSOPHICAL MAGAZINE.

I. *On Deal Pendulum Rods.* By Mr. E. WALKER.

TO MR. TILLOCH,—SIR,

As my paper, containing a short abstract of the rates of going of clocks with wooden pendulum rods, may appear to some of your readers a communication of too little importance to obtain a place in the Philosophical Magazine, it may not be improper to observe, that it is only from such registers we can judge how much one time-keeper is preferable to another. For, who would believe, without having recourse to facts, that clocks with deal pendulum rods perform *nearly* as well as the transit clock at the Royal Observatory?

The performance of my clock shows some properties in pendulums with deal rods, which differ from those composed of rods of different metals, to counteract the effects of heat and cold.—It evidently appears from my former paper* :

First, That this clock lost of true time at one season of the year and gained at another.

Secondly, That twice every year it went true time : and,

Thirdly, That those variations took place regularly during eight years.

The same paper also shows, that there is very little difference in the rates of the four pendulums, although they were made by different artists at different times, and consequently that they were made out of different pieces of wood.

When the performance of my clock is compared with that of the celebrated astronomical clock at Greenwich with a gridiron pendulum, made by Mr. John Shelton, under the

* Philosophical Magazine, vol. xxxiii. p. 30.

direction of Mr. Graham, the difference is much less than might be expected.

The following variations of the daily rate of the Greenwich clock were taken from Dr. Maskelyne's observations of the sun.

Table of greatest Variations in the daily Rate of the transit Clock at the Royal Observatory.

		Clock varies from sidereal time per day.	Greatest annual variation in the daily rate of the clock.
1793.	April 4 to 15	+ 2 ^{''} 10	3.07
	May 12 to 13	- 0.97	
1794.	February 25 to 26	+ 2 ^{''} 10	4.63
	December 18 to 19	- 2.53	
1795.	January 3 to 4	+ 3.74	3.75
	August 10 to 11	- 0.01	
1796.	May 6. Raised the bob of the pendulum.		
1797.	July 31. Ditto.		
1798.	July 31. Clock was cleaned, and the compensation for heat and cold increased.		
1799.	January 15 to 16	- 0.87	2.71
	December 28 to 29	+ 1.84	
1800.	May 2 to 3	- 0.41	4.60
	December 3 to 4	+ 4.16	
1766*	May 6 to 7	+ 1.34	4.64
	August 1 to 2	- 3.30	

Now, the sum of the last column in the above table divided by 6, gives the mean annual variation in the daily rate of the transit clock at Greenwich for six years = 3.9".

And thus the mean annual variation of my clock is found for the same number of years = 5.41". Consequently the transit clock at the Royal Observatory went only 1.51" per annum nearer true time, than a clock with a pendulum rod of wood.—Nor is this a matter that need astonish any one who understands the construction of the two pendulums.

In the gridiron pendulum there is some friction, which

* See an account of the going of Mr. Harrison's watch, at the Royal Observatory.

ought always to be avoided in any compensation applied to time-keepers: and moreover, the length of the pendulum may be increased by its own weight; indeed, the great number of times that the bob of the transit clock at the Royal Observatory has been raised, renders this supposition more than probable.

In a pendulum with a wooden rod there is no friction; and as my pendulum was not altered during six successive years, except by the vicissitudes of dryness and moisture, the weight of the bob or lens had no tendency to increase the length of the rod. And it may be further observed, that, as the cleaning of the clock made no alteration in its daily rate, it seems probable that the pendulum is the only part of it which measures the time into equal portions.

It may not be foreign to my subject to explain the hygrometer which I made use of to determine that the length of this pendulum was altered by dryness and moisture, not by heat and cold.

It is not necessary that we should always have recourse to philosophical instruments to investigate the operations of Nature; for instruments made for ordinary purposes may sometimes, by common observation, lead us to new truths.

My clock stands in a room in which there has been no fire for many years. In this situation the clock case, which is made of mahogany, acts as a hygrometer. For in the driest season of the year the door is so contracted as not to touch one side of the case; but when the atmosphere is very moist the door is so much increased in breadth that it cannot be opened, without using a force which might alter the rate of the clock.

When the door was too little for the clock case, the clock always gained of true time, but it always lost when the door could not be opened. Hence it is evident, that a damp atmosphere, which increased the breadth of the clock case door, increased the length of the pendulum rod; and a dry atmosphere, which contracted the breadth of the door, contracted, at the same time, the deal rod of the pendulum.

I am, sir, your very humble servant,

Lynn, July 5, 1809.

E. WALKER.

H. *The Bakerian Lecture. An Account of some new analytical Researches on the Nature of certain Bodies, particularly the Alkalies, Phosphorus, Sulphur, Carbonaceous Matter, and the Acids hitherto undecomposed; with some general Observations on Chemical Theory.* By HUMPHRY DAVY, Esq., Sec. R.S., F.R.S. Edin., and M.R.I.A.

[Continued from vol. xxxiii. p. 488.]

As an inflammable gas alone, having the obvious properties of hydrogen is given off during the action of potassium upon ammonia, and as nothing but gases apparently the same as hydrogen and nitrogen, nearly in the proportions in which they exist in volatile alkali, are evolved during the exposure of the compound to the degree of heat which I have specified; and as the residual substance produces ammonia with a little hydrogen by the action of water, it occurred to me, that, on the principles of the antiphlogistic theory, it ought to be a compound of potassium, a little oxygen and nitrogen, or a combination of a suboxide of potassium and nitrogen; for the hydrogen disengaged in the operations of which it was the result, nearly equalled the whole quantity contained in the ammonia employed; and it was easy to explain the fact of the reproduction of the ammonia by water, on the supposition, that by combination with one portion of the oxygen of the water, the oxide of potassium became potash, and by combination with another portion and its hydrogen, the nitrogen was converted into volatile alkali.

With a view to ascertain this point, I made several experiments on various residuums, procured in the way that I have just stated, from the action of equal quantities of potassium on dry ammonia in platina trays, each portion of metal equalling six grains.

In the first trials, I endeavoured to ascertain the quantity of ammonia generated by the action of water upon a residuum, by heating it with muriate of lime or potash partially deprived of moisture; and after several trials, many of which failed, I succeeded in obtaining four cubical inches and a half of ammonia. In three other cases, where there was reason

to suspect a small excess of water, the quantities of ammonia were three cubical inches and a half, three and eight tenths, and four and two tenths.

These experiments were performed in the iron tube used for the former process; the tray was not withdrawn; but the salt introduced in powder, and the apparatus exhausted as before, then filled with hydrogen, and then gently heated in a small portable forge.

Having ascertained what quantity of ammonia was given off from the residuum, I endeavoured to discover what quantity of nitrogen it produced in combustion, and what quantity of oxygen it absorbed. The methods that I employed, were by introducing the trays into vessels filled with oxygen gas over mercury. The product often inflamed spontaneously, and could always be made to burn by a slight degree of heat.

In the trial that I regard as the most accurate, two cubical inches and a half of oxygen were absorbed, and only a cubical inch and one-tenth of nitrogen evolved.

Surprised at the smallness of the quantity of the nitrogen, I sought for ammonia in the products of these operations; but various trials convinced me that none was formed. I examined the solid substances produced, expecting nitrous acid; but the matter proved to be dry potash, apparently pure, and not affording the slightest traces of acid.

The quantity of nitrogen existing in the ammonia, which this residuum would have produced by the action of *water*, supposing the volatile alkali decomposed by electricity, would have equalled at least two cubical inches and a quarter.

I heated the same proportions of residuum with the red oxide of mercury, and the red oxide of lead in vacuo, expecting that when oxygen was supplied in a gradual way, the result might be different from that of combustion; but in neither of these cases did the quantity of nitrogen exceed a cubical inch and a half.

But on what could this loss of nitrogen depend; Had it entered into any unknown form with oxygen; or did it not really exist in the residuum in the same quantity, as in the ammonia produced from it?

I hoped that an experiment of exposing the residuum to intense heat might enlighten the inquiry. I distilled one of the portions which had been covered with naphtha, in a tube of wrought platina made for the purpose. The tube had been exhausted and filled with hydrogen, and exhausted again, and was then connected with a pneumatic mercurial apparatus. Heat was at first slowly applied till the naphtha had been driven over. It was then raised rapidly by an excellent forge. When the tube became cherry red, gas was developed; it continued to be generated for some minutes. When the tube had received the most intense heat that could be applied, the operation was stopped. The quantity of gas collected, making the proper corrections and reductions, would have been three cubical inches and a half at the mean temperature and pressure. Twelve measures of it were mixed with six of oxygen gas, the electrical spark was passed through the mixture; a strong inflammation took place, the diminution was to three measures and a half, and the residuum contained oxygen. This experiment was repeated upon different quantities with the same comparative results.

In examining the platina tube, which had a screw adapted to it at the lower extremity, by means of which it could be opened, the lower part was found to contain potash, which had all the properties of the pure alkali, and in the upper part there was a quantity of potassium. Water poured into the tube produced a violent heat and inflammation, but no smell of ammonia.

This result was so unexpected and so extraordinary, that I at first supposed there was some source of error. I had calculated upon procuring nitrogen as the only aëriform product; I obtained an elastic fluid which gave much more diminution by detonation with oxygen, than that produced from ammonia by electricity.

I now made the experiment, by heating the entire fusible substance, from six grains of potassium which had absorbed twelve cubical inches of ammonia, in the iron tube, in the manner before-described. The heat was gradually raised to whiteness, and the gas collected in two portions. The

whole quantity generated, making the usual corrections for temperature and pressure, and the portion of hydrogen originally in the tube, and the residuum, would have been fourteen cubical inches and a half at the mean degree of the barometer and thermometer. Of these, nearly a cubical inch was ammonia and the remainder a gas, of which the portion destructible by detonation with oxygen, was to the indestructible portion, as 2·7 to 1.

The lower part of the tube, where the heat had been intense, was found surrounded with potash in a vitreous form; the upper part contained a considerable quantity of potassium.

In another similar experiment, made expressly for the purposes of ascertaining the quantity of potassium recovered, the same elastic products were evolved. The tube was suffered to cool, the stop-cock being open in contact with mercury, it was filled with mercury, and the mercury displaced by water; when two cubical inches and three quarters of hydrogen gas were generated, which proved that at least two grains and a half of potassium had been revived.

Now, if a calculation be made upon the products in these operations, considering them as nitrogen and hydrogen, and taking the common standard of temperature and pressure, it will be found, that by the decomposition of 11 cubical inches of ammonia equal to 2·05 grains, there is generated 3·6 cubical inches of nitrogen, equal to 1·06 grains, and 9·9 cubical inches of hydrogen, which added to that disengaged in the first operation equal to about 6·1 cubical inches, are together equal to ·382 grains; and the oxygen added to 3·5 grains of potassium would be ·6 grains, and the whole amount is 2·04 grains; and $2·05 - 2·04 = ·01$. But the same quantity of ammonia, decomposed by electricity, would have given 5·5 cubical inches of nitrogen equal to 1·6 grains, and only 14 cubical inches of hydrogen* equal to ·33, and allowing the separation of oxygen in this process in water, it cannot be estimated at more than ·11 or ·12.

So that if the analysis of ammonia by electricity at all approaches towards accuracy; in the process just described,

* See Philosophical Transactions for 1808, p. 40.

there is a considerable loss of nitrogen, and a production of oxygen and inflammable gas.

And in the action of water upon the residuum, in the experiment page 52, there is an apparent generation of nitrogen.

How can these extraordinary results be explained?

The decomposition and composition of nitrogen seem proved, allowing the correctness of the data; and one of its elements appears to be oxygen; but what is its other elementary matter?

Is the gas that appears to possess the properties of hydrogen, a new species of inflammable aëriiform substance?

Or has nitrogen a metallic basis which alloys with the iron or platina?

Or is water alike the *ponderable* matter of nitrogen, hydrogen, and oxygen?

Or is nitrogen a compound of hydrogen with a larger proportion of oxygen than exists in water?

These important questions, the two first of which seem the least likely to be answered in the affirmative, from the correspondence between the weight of the ammonia decomposed, and the products, supposing them to be known substances, I shall use every effort to solve by new labours, and I hope soon to be able to communicate the results of further experiments on the subject to the Society.

As the inquiry now stands, it is however sufficiently demonstrative, that the opinion which I had ventured to form respecting the decomposition of ammonia in this experiment, is correct; and that MM. Gay Lussac's and Thenard's idea of the decomposition of the potassium, and their theory of its being compounded of hydrogen and potash, are unfounded.

For a considerable part of the potassium is recovered unaltered, and in the entire decomposition of the fusible substance, there is only a small excess of hydrogen above that existing in the ammonia acted upon.

The mere phænomena of the process likewise, if minutely examined, prove the same thing.

After the first slight effervescence, owing to the water absorbed by the potash formed upon the potassium during its exposure

exposure to the air, the operation proceeds with the greatest tranquillity. No elastic fluid is given off from the potassium; it often appears covered with the olive-coloured substance, and as if it were evolving hydrogen; this must pass through the fluid; but even to the end of the operation, no such appearance occurs.

The crystallized and spongy substance, formed in the first part of the process, I am inclined to consider as a combination of ammonium and potassium, for it emits a smell of ammonia when exposed to air, and is considerably lighter than potassium.

I at first thought that a solid compound of hydrogen and potassium might be generated in the first part of this operation: but experiments on the immediate action of potassium and hydrogen did not favour this opinion. Potassium, as I ventured to conclude in the Bakerian Lecture for 1807*, is very

* MM. Gay Lussac and Thenard seem to be of a different opinion. In the *Moniteur*, to which I have so often referred, it is related, that these distinguished chemists, exposing hydrogen to potassium at a high temperature, found that the hydrogen was absorbed, and that it formed a compound with the potassium of a light gray colour, from which hydrogen was capable of being obtained by the action of water or mercury.

After a number of trials, I have not been able to witness this result. In an experiment which I made in the presence of Mr. Pepys, and which I have often repeated, and twice before a numerous assembly, in retorts of plate glass, four grains of potassium were heated in fourteen cubical inches of pure hydrogen. At first, white fumes arose and precipitated themselves in the neck of the retort. When a considerable film of the precipitate had collected, its colour appeared a bright gray, and after the first two or three minutes, it ceased to be formed.

The bottom of the retort was heated to redness, when the potassium began to sublime and condense on the sides.

The process was stopped, and the retort suffered to cool. The absorption was not equal to a quarter of a cubical inch. When the retort was broken, the gas in passing into the atmosphere, produced an explosion with most vivid light, and white fumes. The potassium remaining in the retort, and that which had sublimed, seemed unaltered in their properties.

The grayish substance inflamed by the action of water, but did not seem to be combinable with mercury. I am inclined to attribute its formation to the agency of moisture suspended in the hydrogen, and to consider it as a triple compound of potassium, oxygen, and hydrogen.

When potassium is heated in a gas containing hydrogen, and from $\frac{1}{15}$ to $\frac{1}{10}$ of common air, it is formed in greater quantities, and a crust of it covers the
metal

very soluble in hydrogen; but, under common circumstances, hydrogen does not seem to be absorbable by potassium.

III. *Analytical Experiments on Sulphur.*

I have referred, on a former occasion*, to the experiments

metal, and in the process there is an absorption both of hydrogen and oxygen. It is likewise produced in experiments on the generation of potassium by exposing potash to ignited iron, at the time (I believe) that common air is admitted, during the cooling of the tube.

It is non-conducting, inflames spontaneously in air, and produces potash and aqueous vapour by its combustion.

When potassium is heated in hydrogen in a flint glass retort, or even for a great length of time in a green glass retort, there is an absorption of the gas; but this is independent of the presence of potassium, and is owing to the action of the metallic oxides in the glass upon the hydrogen.

If a solid compound of hydrogen and potassium could be formed, we might expect its existence in the experiment with the gun-barrel, in which potassium is exposed to hydrogen at almost every temperature; but the metal formed in this process, when proper precautions are taken to exclude carbonaceous matters, is uniform in its properties, and generates for equal quantities, equal proportions of hydrogen by the action of water.

The general phenomena of this operation, show indeed that the solution of potassium in hydrogen is intimately connected with the general principle of the decomposition, and confirm my first idea of the action of the two bodies.

Hydrogen dissolves a large quantity of potassium by heat, but the greater portion is precipitated on cooling. The attractions which determine the chemical change, seem to be that of iron for oxygen, of iron for potassium, and of hydrogen for potassium; and in experiments, in which a very intense heat is used for the production of potassium by iron, I have often found, that the gas which comes over, though it has passed through a tube cooled by ice, inflames spontaneously in the atmosphere, and burns with a most brilliant light which is purple at the edges, and throws off a dense vapour containing potash.

Sodium appears to be almost insoluble in hydrogen, and this seems to be one reason why it cannot be obtained, except in very minute quantities, in the experiment with the gun-barrel.

Sodium, though scarcely capable of being dissolved in hydrogen alone, seems to be soluble in the compound of hydrogen and potassium. By exposing mixtures of potash and soda to ignited iron, I have obtained some very curious alloys; which, whether the potassium or the sodium was in excess, were fluid at common temperatures. The compound containing an excess of potassium was even lighter than potassium (probably from its fluidity). All these alloys were in the highest degree inflammable. When a globule of the fluid alloy was touched by a globule of mercury, they combined with a heat that singed the paper upon which the experiment was made, and formed, when cool, a solid so hard, as not to be cut by a knife.

* Bakerian Lecture, 1803, p. 16.

of Mr. Clayfield and of M. Berthollet, jun., which seemed to show that sulphur, in its common form, contained hydrogen. In considering the analytical powers of the Voltaic apparatus, it occurred to me, that though sulphur, from its being a non-conductor, could not be expected to yield its elements to the electrical attractions and repulsions of the opposite surfaces, yet that the intense heat, connected with the contact of these surfaces, might possibly effect some alteration in it, and tend to separate any elastic matter it might contain.

On this idea some experiments were instituted in 1807. A curved glass tube, having a platina wire hermetically sealed in its upper extremity, was filled with sulphur. The sulphur was melted over a spirit lamp; and a proper connection being made with the Voltaic apparatus of one hundred plates of six inches, in great activity, a contact was made in the sulphur by means of another platina wire. A most brilliant spark, which appeared orange coloured through the sulphur, was produced, and a minute portion of elastic fluid rose to the upper extremity of the tube. By a continuation of the process for nearly an hour, a globule equal to about the tenth of an inch in diameter was obtained, which, when examined, was found to be sulphuretted hydrogen.

This result perfectly coincided with those which have been just mentioned; but as the sulphur that I had used was merely in its common state, and as the ingenious experiments of Dr. Thomson have shown that sulphur in certain forms may contain water, I did not venture, at that time, to form any conclusion upon the subject.

In the summer of the present year, I repeated the experiment with every precaution. The sulphur that I employed was Sicilian sulphur, that had been recently sublimed in a retort filled with nitrogen gas, and that had been kept hot till the moment that it was used. The power applied was that of the battery of five hundred double plates of six inches, highly charged. In this case the action was most intense, the heat strong, and the light extremely brilliant; the sulphur soon entered into ebullition, elastic matter was formed in great quantities, much of which was permanent; and the sulphur,

sulphur, from being of a pure yellow, became of a deep red brown tint.

The gas, as in the former instance, proved to be sulphuretted hydrogen. The platina wires were considerably acted upon; the sulphur, at its point of contact with them, had obtained the power of reddening moistened litmus paper.

I endeavoured to ascertain the quantity of sulphuretted hydrogen evolved in this way from a given quantity of sulphur, and for this purpose I electrized a quantity equal to about two hundred grains in an apparatus of the kind I have just described, and when the upper part of the tube was full of gas, I suffered it to pass into the atmosphere; so as to enable me to repeat the process.

When I operated in this way, there seemed to be no limit to the generation of elastic fluid, and in about two hours a quantity had been evolved, which amounted to more than five times the volume of the sulphur employed. From the circumstances of the experiment, the last portion only could be examined, and this proved to be sulphuretted hydrogen. Towards the end of the process, the sulphur became extremely difficult of fusion, and almost opaque, and when cooled and broken, was found of a dirty brown colour.

The experiments upon the union of sulphur and potassium, which I laid before the Society last year, prove that these bodies act upon each other with great energy, and that sulphuretted hydrogen is evolved in the process, with intense heat and light.

In heating potassium in contact with compound inflammable substances, such as resin, wax, camphor, and fixed oils in close vessels out of the contact of the air, I found that a violent inflammation was occasioned, that hydrocarbonate was evolved; and that when the compound was not in great excess, a substance was formed, spontaneously inflammable at common temperatures, the combustible materials of which were charcoal and potassium.

Here was a strong analogy between the action of these bodies and sulphur on potassium. Their physical properties likewise resemble those of sulphur; for they agree in being non-conductors, whether fluid or solid, in being transparent

transparent when fluid, and semi-transparent when solid, and highly refractive; their affections by electricity are likewise similar to those of sulphur; for the oily bodies give out hydrocarbonate by the agency of the Voltaic spark, and become brown, as if from the deposition of carbonaceous matter.

But the resinous and oily substances are compounds of a small quantity of hydrogen and oxygen, with a large quantity of a carbonaceous basis. The existence of hydrogen in sulphur is fully proved, and we have no right to consider a substance, which can be produced from it in such large quantities, merely as an accidental ingredient.

The oily substances in combustion, produce two or three times their weight of carbonic acid and some water; I endeavoured to ascertain whether water was formed in the combustion of sulphur in oxygen gas, dried by exposure to potash; but in this case sulphureous acid is produced in much larger quantities than sulphuric acid, and this last product is condensed with great difficulty. In cases, however, in which I have obtained, by applying artificial cold, a deposition of acid in the form of a film of dew in glass retorts out of the contact of the atmosphere, in which sulphur had been burned in oxygen gas hygrometrically dry, it has appeared to me less tenacious and lighter than the common sulphuric acid of commerce, which in the most concentrated form in which I have seen it, namely, at 1.855, gave abundance of hydrogen as well as sulphur, at the negative surface in the Voltaic circuit, and hence evidently contained water.

The reddening of the litmus paper, by sulphur that had been acted on by Voltaic electricity, might be ascribed to its containing some of the sulphuretted hydrogen formed in the process; but even the production of this gas, as will be immediately seen, is an evidence of the existence of oxygen in sulphur.

In my early experiments on potassium, procured by electricity, I heated small globules of potassium in large quantities of sulphuretted hydrogen, and I found that sulphuret of potash was formed; but this might be owing to the water dissolved

dissolved in the gas, and I ventured to draw no conclusion till I had tried the experiment in an unobjectionable manner.

I heated four grains of potassium in a retort of the capacity of twenty cubical inches; it had been filled after the usual processes of exhaustion with sulphuretted hydrogen, dried by means of muriate of lime that had been heated to whiteness; as soon as the potassium fused, white fumes were copiously emitted, and the potassium soon took fire, and burnt with a most brilliant flame, yellow in the centre and red towards the circumference*.

The diminution of the volume of the elastic matter, in this operation, did not equal more than two cubical inches and a half. A very small quantity of the residual gas only was absorbable by water. The non-absorbable gas was hydrogen, holding a minute quantity of sulphur in solution.

A yellow sublimate lined the upper part of the retort, which proved to be sulphur. The solid matter formed was red at the surface like sulphuret of potash, but in the interior it was dark gray, like sulphuret of potassium. The piece of the retort containing it was introduced into a jar inverted over mercury, and acted upon by a small quantity of dense muriatic acid, diluted with an equal weight of water, when there were disengaged two cubical inches and a quarter of gas, which proved to be sulphuretted hydrogen.

In another experiment, in which eight grains of potassium were heated in a retort of the capacity of twenty cubical inches, containing about nineteen cubical inches of sulphuretted hydrogen, and a cubical inch of phosphuretted hydrogen, which was introduced for the purpose of absorbing the oxygen of the small quantity of common air admitted by the stop-cock, the inflammation took place as before, there was a similar precipitation of sulphur on the sides of the retort; the mass formed in the place of the potassium was orange externally, and of a dark gray colour internally,

* In the *Moniteur*, May 27. 1808, in the account of MM. Gay Lussac's and Thenard's experiments, it is mentioned, that potassium absorbs the sulphur and a part of the hydrogen of sulphuretted hydrogen; but the phenomena of inflammation is not mentioned, nor are the results described.

as in the last instance; and, when acted on by a little water holding muriatic acid in solution, there were evolved from it five cubical inches only of sulphuretted hydrogen.

Both these experiments concur in proving the existence of a principle in sulphuretted hydrogen, capable of destroying partially the inflammability of potassium, and of producing upon it all the effects of oxygen; for, had the potassium combined merely with pure combustible matter, it ought, as will be seen distinctly from what follows, to have evolved, by the action of the acid, a volume of sulphuretted hydrogen, at least equal to that of the hydrogen which an equal weight of uncombined potassium would have produced by its operation upon water.

Sulphuretted hydrogen, as has been long known to chemists, may be formed by heating sulphur strongly in hydrogen gas. I heated four grains of sulphur in a glass retort, containing about twenty cubical inches of hydrogen, by means of a spirit lamp, and pushed the heat nearly to redness. There was no perceptible change of volume in the gas after the process; the sulphur that had sublimed was unaltered in its properties, and about three cubical inches of an elastic fluid absorbable by water were formed: the solution reddened litmus, and had all the properties of a solution of pure sulphuretted hydrogen. Now if we suppose sulphuretted hydrogen to be constituted by sulphur dissolved in its unaltered state in hydrogen, and allow the existence of oxygen in this gas; its existence must likewise be allowed in sulphur, for we have no right to assume that sulphur in sulphuretted hydrogen is combined with more oxygen than in its common form: it is well known, that when electrical sparks are passed through sulphuretted hydrogen, a considerable portion of sulphur is separated without any alteration in the volume of the gas. This experiment I have made more than once, and I found that the sulphur obtained, in fusibility, combustibility, and other sensible properties, did not perceptibly differ from common sublimed sulphur.

According to these ideas, the intense ignition produced by the action of sulphur, on potassium and sodium, must not be ascribed merely to the affinity of the metals of the

alkalies for its basis, but may be attributed likewise to the agency of the oxygen that it contains.

The minute examination of the circumstances of the action of potassium and sulphur likewise confirms these opinions.

When two grains of potassium and one of sulphur were heated gently in a green glass tube filled with hydrogen, and connected with a pneumatic apparatus, there was a most intense ignition produced by the action of the two bodies, and one-eighth of a cubical inch of gas was disengaged, which was sulphuretted hydrogen. The compound was exposed in a mercurial apparatus to the action of liquid muriatic acid; when a cubical inch and quarter of aëriiform matter was produced, which proved to be pure sulphuretted hydrogen.

The same experiment was repeated, except that four grains of sulphur were employed instead of one. In this case, a quarter of a cubical inch of gas was disengaged during the process of combination; and when the compound was acted upon by muriatic acid, only three quarters of a cubical inch of sulphuretted hydrogen was obtained.

Now, *sulphuret* of potash produces sulphuretted hydrogen by the action of an acid; and if the sulphur had not contained oxygen, the hydrogen evolved by the action of the potassium in both these experiments ought to have equalled at least two cubical inches, and the whole quantity of sulphuretted hydrogen ought to have been more: and that so much less sulphuretted hydrogen was evolved in the second experiment, can only be ascribed to the larger quantity of oxygen furnished to the potassium by the larger quantity of the sulphur.

I have made several experiments of this kind with similar results. Whenever equal quantities of potassium were combined with unequal quantities of sulphur, and exposed afterwards to the action of muriatic acid, the largest quantity of sulphuretted hydrogen was furnished by the product containing the smallest proportion of sulphur, and in no case was the quantity of gas equal in volume to the quantity of hydrogen which would have been produced by the mere action of potassium upon water.

From

From the general tenour of these various facts, it will not be, I trust, unreasonable to assume, that sulphur, in its common state, is a compound of small quantities of oxygen and hydrogen with a large quantity of a basis that produces the acids of sulphur in combustion, and which, on account of its strong attractions for other bodies, it will probably be very difficult to obtain in its pure form.

In metallic combinations even, it still probably retains its oxygen and part of its hydrogen. Metallic sulphurets can only be partially decomposed by heat, and the small quantity of sulphur evolved from them in this case when perfectly dry and out of the contact of air, as I found in an experiment on the sulphurets of copper and iron, exists in its common state, and acts upon potassium, and is affected by electricity in the same manner as native sulphur.

[To be continued.]

III. *An Inquiry into the Terrestrial Phænomena produced by the Action of the Ocean.* By JOHN CARR, Esq., of Manchester.—No. I.

TO MR. TILLOCH,—SIR,

HAVING in my last paper offered explanations of the numerous excavations which streams of fresh water have effected on the surface of our globe, I am now to undertake, in furtherance of my former engagement, an inquiry into the terrestrial phænomena which the waters of the ocean have left for our contemplation.

Of the whole surface of the earth the proportion of land is supposed to be about a third only; and from the gravitating fluidity of water, which constantly disposes it to fall in the lowest descending direction, until it reaches a hollow where it is equally supported on all sides, it might seem reasonable to conclude that the present elevations of land are barrier heights which the ocean never can have ascended, and that its present limits are those by which it has ever been circumscribed. But this, like every other conclusion on natural effects without observation for its basis, is illusory and

erroneous; and a very moderate acquaintance with some of the ordinary phænomena of the earth will afford ample conviction, that over every portion of our present existing continents the waters of the ocean have rolled during a period to which we can assign no limit.

Proofs of this extraordinary occurrence are abundantly disseminated over every part of every country. Wherever the earth has been penetrated, a succession of strata alternating and varying, distinctly and specifically, is met with under forms which unequivocally demonstrate that they have all originated from aqueous deposition; and the vast remains of marine productions, so extensively distributed amongst some, and in others forming whole and distinct strata, equally establish, that they have had one common origin. *They have all in succession been beds of the ocean.* Nor has any limit yet been discovered, by any natural or artificial means of examination, to this peculiar conformation of our globe. The high fronts and deep ravines and gullies of mountains, the abrupt faces of precipitous valleys, shores, and islands, the natural cavernous excavations and the artificial perforations of every description, which have been dug by the avaricious cupidity or the necessary wants of man, all and every where display regularly stratified beds, generally parallel with each other, but always varying in their dimensions, density and materials, and every where exhibiting a uniformity of appearance, which admits of no other explanation than that of a slow and progressive precipitation from an aqueous fluid.

This universal prevalence of the formation of strata in the interior of the earth, is again most singularly contrasted by the indubitable evidence of an almost equally extensive destruction of other strata on the surface. The elevated direction and abrupt termination of extensive strata from various heights, conclusively establish that they were once continuous to an unknown extent. Many of our principal eminences are formed by strata inclined from the horizon, and terminating in high angular asperities, presenting from thence a bold precipitous face, and on the other side gentle declivities of receding strata.

The

The extensive denudations of numerous districts laying bare the identical strata, which in the vicinity are found reposing under vast depths of other incumbent strata, leave us without doubt that the superincumbent materials, however massive and onerous, have been swept away from off the denudated tracts. A similar disruption, but on a yet more extended scale, is forcibly inculcated by these singular eminences of isolated material which cannot be identified with any of the surrounding strata, and which are, therefore, only the remaining patches of the stratum to which they formerly belonged. But the most stupendous proofs of destructive disruption, are to be found in the numerous and highly elevated ranges of stratified mountains, whose formation, while it perfectly accords with, can admit of no other explanation than that of their being the remaining fragments of extensive countries which have disappeared. And here again, as we were constrained to refer the formation of all the strata to the action of the sea, we are in like manner compelled to assign their disruptive transportation to the only natural agents whose gigantic forces and powers of mobility are in any degree commensurate to such mighty performances,—the numerous and sweeping currents of the ocean.

Let us now turn to the sea itself, and endeavour to ascertain the nature of its present beds, and the changes which they are experiencing from the mighty effects of its powerful agency. The active and interested concerns of commerce have occasioned such extensive and accurate soundings to be taken of vast and various tracts of the sea, that we have from thence actually acquired a more correct knowledge of extensive regions over which the ocean is incessantly rolling, than of many portions of those countries which emerged from its waves so many centuries ago; and from these it has been fully ascertained, that extensive horizontal plains are as rare below as above the great receptacle of waters, and that inequalities, in every respect similar, prevail in both regions, of banks, hollows, declivities, and elevations, from the least perceptible rise, up to the precipitous fronts of unfathomable rocks. With this corresponding similitude of surface there has also been discovered an equally corre-

sponding agreement in the conformation of its beds ; and so fully has the identity in both cases been established, that, were any extent of the present bottom of the ocean laid dry, and allowed a sufficient time to consolidate and acquire a vegetable covering, there can be no question that it would exhibit all the diversified exterior, and all the internal conformation, of our present inhabited countries.

We also know that the bottom of the sea is continually receiving large accessions of earthy and other materials, conveyed into it by rivers and land floods. Even in some of the rivers of our own country, the turbid waters of a summer's flood may be seen distinctly spreading themselves out for miles after their entrance into the sea ; and, were an estimation practicable, the annual quantity spread over the beds of the neighbouring sea, by such a river only, would be found very considerable indeed : but if we take into the estimation the accumulated produce of all the rivers on the globe, the annual accession must be immense ; and this increase, repeated through a succession of innumerable ages, must add incalculable masses of fresh and various material to extensive tracts beneath the sea. It may be worth remarking by the way, that nearly the whole of the materials carried by this mode into the sea is from the surface, and consequently from the richest part of the soil, abounding in a large proportion of vegetable and animal remains ; and it would certainly be at express variance with every other provident and œconomical provision of Nature, to imagine that this daily deterioration of our lands has no other ultimate purpose than to incumber the fathomless deeps with endless succession of superfluous waste.

But though this vast addition to the beds of the ocean is of itself a sufficiently important consideration in the present inquiry, it is, I conceive, comparatively with other agency, but a trivial source of terrestrial alteration ; and I think we can only look to the numerous and impetuous marine currents, sweeping with ponderous attrition, and irresistible force, over the abraded beds of the sea, for the cause of these stupendous phænomena, which arrest our attention and elevate our astonishment in geological research.

It is obvious to imagine, and strictly consonant with all our experience to believe, that a current of the ocean pressing with a weight and force of which we can form no estimate, and for a duration which eludes all calculation, over extensive tracts of sea beds, abounding in every variety of inequality, must carry off immense quantities of materials; and transport them to distant situations, where they will be extensively precipitated in nearly the same order in which they were taken up, and will, therefore, in their new situations, form other strata not greatly dissimilar from those which were broken up. It will also readily occur, that all the superior eminences in the course of the current will experience a far more extraordinary degree of force and violence than those parts which lie lower; and that in all these eminences abounding in strata of rock, the fronts which face the current will be laid bare and beaten into bold angular abruptions, while the opposite sides, protected by the eminences, will fall off in gentle declivities, precisely similar to what we actually observe in all the hilly districts of every country, where the precipitous faces and declivous sides so wonderfully coincide in the same respective direction. This singular and interesting uniformity in the direction of the abrupt and declivous sides of the elevations of almost every country, frequently ranging to an unknown extent, is entirely an effect which a vast marine current would necessarily produce on all the eminences in its course; and it is, I think, utterly inexplicable by any other natural agency.

One of the principal currents with which we are acquainted, is that stupendous movement of waters in the Atlantic Ocean which is nautically designated the Gulf Stream. It originates in the diurnal rotation and centrifugal force of the earth, aided by the trade winds, giving the waters of the main ocean an impulsive direction from east to west; and a portion of this vast movement being finally impelled into the Mexican Gulf, is glanced off from thence through the Straits of Bahama, with an impetus which hurries it over a breadth of fifty miles, at four miles an hour, to the far distant banks of Newfoundland, where it can still be clearly identified by its dark colour and superior temperature. In

this extensive circuit of moving waters from the Indian ocean round into the northern seas, if we justly appreciate the length of its duration, the incalculable weight with which it must incessantly press against all opposing obstacles, the countless inequality of depths over which it must roll, and the extensive tracts of various, and yielding strata subject to its constant attrition, it will surely be consonant to all our experience and analogous reasoning, to believe that it is now progressively transporting extensive beds of strata from one distant region to another, and beating into high abrupt fronts many of the more exalted eminences in its course, insomuch that, were its whole tract laid open to our inspection, it would unquestionably exhibit proofs of disruption, denudation, transition, and all the bolder phænomena of geology with which we are already familiar. The existence of the extensive banks of Newfoundland is of itself sufficient to establish this. These banks are situated amongst the last expiring eddies of the stream, where the most considerable precipitous depositions might be expected; and the countless myriads of fish, resorting thither for food, are proofs of the amazing quantities of vegetable and animal remains brought by the stream.

Though this current is certainly one of the most extensive on our globe, there are many others far superior in their rapidity, and consequently in their forces; and indeed so numerous are the currents of the ocean, and so diversified in their powers and direction, that we can assign no imaginable limits either to the variety or the magnitude of their effects. Even the general tides are in themselves powerful and extensive currents; and when aided by those occasional and terrible tempests which all seas are more or less subject to, their alterative effects must be such, as we have no sufficient data to estimate.

It would certainly be a superficial objection to the extensive transportation of strata by marine currents, to say that the turbid waters surcharged with the earthy materials do not appear at the surface. The fact is not strictly so; for the Gulf stream is palpably darker than the sea which it traverses, and many currents of the ocean are absolutely turbid.

turbid. But it is not necessary to insist on this circumstance ; for the transportation which I contend for is not such a sudden disruption as would give to the current all the muddy opacity of a land flood, but such a gradual and progressive attrition, as, in carrying off the materials, the propulsion of the water and the superior gravity of the transported particles would effectually prevent from appearing at the surface.

The extensive transportation and spread of the various exterior materials of our globe, are facts of which we are as certain as of the light and heat of the solar luminary ; and it is equally certain that the medium of those vast transitions can be no other than the ocean itself. It should also seem to follow from the fairest inductive reasoning, that its currents, while they are the most simple and natural, are also the only marine agency at all equal and applicable to such stupendous effects.

Were it objected that the transportation and formation of strata by marine currents must be local like the currents themselves, it is only necessary to observe, that the materials of all our present countries are so evidently the remaining fragments of the waste and disintegration of other countries, which no longer exist, and bear such palpable characters of such frequent interchanges and successions of land and water, as remove all locality of such currents far beyond the reach of geological determination.

Such, Mr. Editor, are a few of the principal data which authorize our identifying the present operations of the ocean with its former action on our continents, when they too were bottoms of the "vasty deep." The limits of your very select publication have necessarily circumscribed the present outline of so extended a subject : but however brief and imperfect it may be, it is an indispensable preliminary to that investigation of the general phænomena of geology, which my first paper announced ; and in my next I shall pursue the subject by continuing to trace those probabilities, for they are yet no higher in the scale of evidence, which encourage us to imagine that our globe, in common with all its multifarious and interesting species of production, possesses within

within its own governing principles a power of periodic and revolutionary renovation.

I am, sir, your most obedient humble servant,

JOHN CARR.

Princess Street, Manchester,

July 5, 1809.

IV. *An Account of some Experiments, performed with a View to ascertain the most advantageous Method of constructing a Voltaic Apparatus, for the Purposes of Chemical Research.* By JOHN GEORGE CHILDREN, Esq., F.R.S.*

THE late interesting discoveries by Mr. Davy having shown the high importance of the Voltaic battery as an instrument of chemical analysis, it became a desirable object to ascertain that mode of constructing it, by which the greatest effect may be produced, with the least waste of power and expense.

For this purpose, I made a battery, on the new method, with plates of copper and zinc, connected together by leaden straps, soldered on the top of each pair of plates; which are twenty in number, and each plate four feet high, by two feet wide: the sum of all the surfaces being 92160 square inches, exclusive of the single plate at each end of the battery. The trough is made of wood, with wooden partitions well covered with cement, to render them perfectly tight, so that no water can flow from one cell to another. The battery was charged with a mixture of three parts fuming nitrous, and one part sulphuric acid, diluted with thirty parts of water, and the quantity used was 120 gallons.

In the presence, and with the kind assistance of Messrs. Davy, Allen, and Pepys, the following experiments were made.

Experiment 1. Eighteen inches of platina wire, of $\frac{1}{16}$ th of an inch diameter, were completely fused in about twenty seconds.

* From Philosophical Transactions for 1809, Part I.

Exp. 2. Three feet of the same wire were heated to a bright red, visible by strong day-light.

Exp. 3. Four feet of the same wire were rendered very hot; but not perceptibly red by day-light. In the dark, it would probably have appeared red throughout.

Exp. 4. Charcoal burnt with intense brilliancy.

Exp. 5. On iron wire, of about $\frac{1}{16}$ th of an inch in diameter, the effect was strikingly feeble. It barely fused ten inches, and had not power to ignite three feet.

Exp. 6. Imperfect conductors were next submitted to the action of the battery, and barytes, mixed with the red oxide of mercury, and made into a paste with pipe-clay and water, was placed in the circuit; but neither on this nor on any other similar substance was the slightest effect produced.

Exp. 7. The gold leaves of the electrometer were not affected.

Exp. 8. When the cuticle was dry, no shock was given by this battery, and even though the skin was wet, it was scarcely perceptible.

Before I offer any observations on the inferences to be drawn from these experiments, I shall mention some others, performed, for the sake of comparison, with the foregoing, with an apparatus very different in size and number of plates from the one just described.

This second battery was precisely the *Couronne des Tasses* of Sig. Volta, consisting of two hundred pairs of plates, each about two inches square, placed in half pint pots of common queen's ware, and made active by some of the liquor used in exciting the large battery, to which was added a fresh portion of sulphuric acid, equal to about a quarter of a pint to a gallon.

To state as shortly as possible the effects produced by this battery:

Experiment 1. It decomposed potash and barytes readily.

Exp. 2. It produced the metallization of ammonia with great facility.

Exp. 3. It ignited charcoal vividly.

Exp. 4. It caused considerable divergence of the gold leaves of the electrometer.

Exp.

Exp. 5. It gave a vivid spark, after being in action three hours. At the expiration of twenty-four hours, it retained sufficient power to metallize ammonia, and continued, with gradually decreasing energy, to produce the same effect till the end of forty-one hours, when it seemed nearly exhausted.

From the results of the foregoing experiments, which, though simple and not numerous, I trust, are satisfactory, we see Mr. Davy's theory of the mode of action of the Voltaic battery confirmed: he says (in his Paper on some Chemical Agencies of Electricity, Sect. 9, after having shown the effect of induction to increase the electricity of the opposite plates), "the *intensity* increases with the *number*, and the *quantity* with the *extent* of the series."

That this is so, the effects produced on the platina and iron wires, in the first and fifth experiments with the large battery, and the subsequent experiments on imperfect conductors, with the small apparatus, sufficiently prove. The platina wire being a perfect conductor, and not liable to be oxidated, presents no obstacle to the free passage of the electricities through it, which, from the immense quantities given out from so large a surface, evolve, on their mutual annihilation, heat sufficient to raise the temperature of the platina to the point of fusion.

With the iron wire, of $\frac{1}{8}$ th of an inch diameter, the effect is very different, which is explained by the low state of the intensity of the electricity (sufficiently proved by its not causing any divergence of the gold leaves of the electrometer), which being opposed in its passage by the thin coat of oxide, formed on the iron wire, at the moment the circuit is completed, a very small portion only of it is transmitted through the wire. To the same want of intensity is to be attributed the total inability of the large battery to decompose the barytes, and its general weak action on bodies which are not perfect conductors. The small battery, on the contrary, exerts great power on imperfect conductors, decomposing them readily, although its whole surface is more than thirty times less than that of the great battery; but in point of number of plates, it consists of nearly ten times as many as the large one. The long continued action of the small

small battery proves the utility of having the cells of sufficient capacity to hold a large quantity of liquor, by which much trouble of emptying and filling the troughs is avoided, and the action, kept up, without intermission, for a long space of time,—a circumstance, in many experiments, of material consequence. Besides this advantage, with very large combinations, a certain distance between each pair of plates is absolutely necessary, to prevent spontaneous discharges, which will otherwise ensue, accompanied with vivid flashes of electric light, as I have experienced, with a battery of 1250 four-inch plates, on the new construction. And here I beg leave to mention an experiment, which, though not directly in point, cannot be considered as foreign to the subject of this paper. It has been urged, as one proof of the non-identity of the common electricity, and that given out by the Voltaic apparatus, that in the latter there is no striking distance. That objection, however, must cease. I took a small receiver, open at one end; through perforations in the opposite sides of which were placed two wires, with platina points, well polished: one was fixed by cement to the glass, the other was moveable, by means of a fine screw, through a collar of leathers, and the distance between the points was ascertained by a small micrometer attached. This receiver was inverted over well dried potash over mercury, and suffered to stand a couple of days, to deprive the air it contained, as thoroughly as possible, of moisture. The 1250 plates being excited precisely to the same degree as the great battery, mentioned in the beginning of this communication; and the little receiver placed in the circuit, I ascertained its striking distance to be $\frac{1}{50}$ th of an inch. That I might be certain that the air in the apparatus had not become a conductor by increase of temperature, I repeated the experiment several times with fresh cool air, and always with the same result; but perhaps it will be objected, that the striking distance was so small, as not to afford a satisfactory refutation of the argument alluded to, when it is considered to how very great a distance, comparatively, the spark of the common electrical machine can pass through air. The answer to this is obvious: increase
the

the number of the plates, and the striking distance will increase; for we see throughout, the intensity proportioned to the number, and it probably may be carried to such extent, as even to pass through a thicker plate of air than the common spark. The great similarity of the appearance of the electric light of this battery in vacuo, and that of the common machine, might also be urged as an additional proof of the identity of their nature.

The effect of this large combination on imperfect conductors, was, as may be supposed, very great; but of the same platina wire, of which the four-foot plates fused eighteen inches, this battery melted but half an inch, though, had the effect been in the ratio of their surfaces, it should have fused nearly fourteen inches.

The absolute effect of a Voltaic apparatus, therefore, seems to be in the compound ratio of the number and size of the plates: the intensity of the electricity being as the former, the quantity given out as the latter; consequently regard must be had, in its construction, to the purposes for which it is designed. For experiments on perfect conductors, very large plates are to be preferred, a small number of which will probably be sufficient; but where the resistance of imperfect conductors is to be overcome, the combination must be great, but the size of the plates may be small; but if quantity and intensity be both required, then a large number of large plates will be necessary. For general purposes, four inches square will be found to be the most convenient size.

Of the two methods usually employed, that of having the copper and zinc plates joined together only in one point, and moveable, is much better than the old plan of soldering them together, through the whole surface, and cementing them into the troughs: as, by the new construction, the apparatus can be more easily cleaned and repaired, and a double quantity of surface is obtained. For the partitions in the troughs, glass seems the substance best adapted to secure a perfect insulation; but the best of all will be troughs made entirely of Wedgwood's ware,—an idea, I believe, first suggested by Dr. Babington.

V. *On the Origin and Formation of Roots. In a Letter from T. A. KNIGHT, Esq., F.R.S., to the Right Hon. Sir JOSEPH BANKS, K.B., P.R.S.**

MY DEAR SIR,

IN a former communication I have given an account of some experiments, which induced me to conclude that the buds of trees invariably spring from their alburnum, to which they are always connected by central vessels of greater or less length; and in the course of much subsequent experience, I have not found any reason to change the opinion that I have there given †. The object of the present communication is to show, that the roots of trees are always generated by the vessels which pass from the cotyledons of the seed, and from the leaves, through the leaf-stalks and the bark, and that they never, under any circumstances, spring immediately from the alburnum.

The organ, which naturalists have called the radicle in the seed, is generally supposed to be analogous to the root of the plant, and to become a perfect root during germination; and I do not know that this opinion has ever been controverted, though I believe that, when closely investigated, it will prove to be founded in error.

A root, in all cases with which I am acquainted, elongates only by new parts which are successively added to its apex or point, and never, like the stem or branch, by the extension of parts previously organized; and I have endeavoured to show, in a former memoir, that owing to this difference in the mode of the growth of the root and lengthened plumule of germinating seeds, the one must ever be obedient to gravitation, and point towards the centre of the earth, whilst the other must take the opposite direction ‡. But the radicle of germinating seeds elongates by the extension of parts previously organized, and in a great number of cases, which must be familiar to every person's observation, raises the cotyledons out of the mould in which the seed is placed to

* From Philosophical Transactions for 1809, Part I.

† Phil. Trans. 1805.

‡ Ibid. 1806.

vegetate.

vegetate. The mode of growth of the radicle is therefore similar to that of the substance which occupies the spaces between the buds near the point of the succulent annual shoot, and totally different from that of the proper root of the plant, which I conceive to come first into existence during the germination of the seed, and to spring from the point of what is called the radicle. At this period, neither the radicle nor cotyledons contain any alburnum; and therefore the first root cannot originate from that substance; but the cortical vessels are then filled with sap, and apparently in full action, and through these the sap appears to descend which gives existence to the true root.

When first emitted, the root consists only of cellular substance, similar to that of the bark of other parts of the future tree, and within this the cortical vessels are subsequently generated in a circle, inclosing within it a small portion of the cellular substance, which forms the pith or medulla of the root. The cortical vessels soon enter on their office of generating alburnous matter; and a transverse section of the root then shows the alburnum arranged in the form of wedges round the medulla, as it is subsequently deposited on the central vessels of the succulent annual shoot, and on the surface of the alburnum of the stems and branches of older trees*.

If a leaf-stalk be deeply wounded, a cellular substance, similar to that of the bark and young root, is protruded from the upper lip of the wound, but never from the lower; and the leaf-stalks of many plants possess the power of emitting roots, which power cannot have resided in alburnum, for the leaf-stalk does not contain any; but vessels, similar to those of the bark and radicle, abound in it, apparently convey the returning sap; and from these vessels, or perhaps more properly from the fluid they convey, the roots emitted by the leaf-stalk derive their existence †.

If a portion of the bark of a vine, or other tree, which readily emits roots, be taken off in a circle extending round its stem, so as to intercept entirely the passage of any fluid

* Philosophical Transactions for 1801, Plate xxvii.

† Ibid. for 1801.

through the bark; and any body which contains much moisture be applied, numerous roots will soon be emitted into it immediately above the decorticated space; but never immediately beneath it: and when the alburnum in the decorticated-spaces has become lifeless to a considerable depth, buds are usually protruded beneath, but never immediately above it, apparently owing to the obstruction of the ascending sap. The roots, which are emitted in the preceding case, do not appear in any degree to differ from those which descend from the radicles of generating seeds, and both apparently derive their matter from the fluid which descends through the cortical vessels.

There are several varieties of the apple tree, the trunks and branches of which are almost covered with rough excrescences, formed by congeries of points which would have become roots under favourable circumstances; and such varieties are always very readily propagated by cuttings. Having thus obtained a considerable number of plants of one of these varieties, the excrescences began to form upon their stems when two years old, and mould being then applied to them in the spring, numerous roots were emitted into it early in the summer. The mould was at the same time raised round, and applied to, the stems of other trees of the same age and variety, and in every respect similar, except that the tops of the latter were cut off a short distance above the lowest excrescence, so that there were no buds or leaves from which sap could descend to generate or feed new roots; and under these circumstances no roots, but numerous buds were emitted, and these buds all sprang from the spaces and points, which under different circumstances had afforded roots. The tops of the trees last mentioned, having been divided into pieces of ten inches long, were planted as cuttings, and roots were by these emitted from the lowest excrescences beneath the soil, and buds from the uppermost of those above it.

I had anticipated the result of each of the preceding experiments; not that I supposed, or now suppose, that roots can be changed into buds, or buds into roots; but I had before proved that the organization of the alburnum is better

calculated to carry the sap it contains, from the root upwards, than in any other direction; and I concluded that the sap when arrived at the top of the cutting through the alburnum would be there employed, as I had observed in many similar cases, in generating buds, and that these buds would be protruded where the bark was young and thin, and consequently afforded little resistance*. I had also proved the bark to be better calculated to carry the sap towards the roots than in the opposite direction, and I thence inferred that as soon as any buds, emitted by the cuttings, afforded leaves, the sap would be conveyed from these to the lower extremity of the cuttings by the cortical vessels, and be there employed in the formation of roots*.

Both the alburnum and bark of trees evidently contain their true sap; but whether the fluid, which ascends in such cases as the preceding through the alburnum to generate buds, be essentially different from that which descends down the bark to generate roots, it is perhaps impossible to decide. As nature, however, appears in the vegetable world to operate by the simplest means; and as the vegetable sap, like the animal blood, is probably filled with particles which are endued with life, were I to offer a conjecture, I am much more disposed to believe that the same fluid, even by merely acquiring different motions, may generate different organs, than that two distinct fluids are employed to form the root, and the bud and leaf.

When alburnum is formed in the root, that organ possesses, in common with the stem and branches, the power of producing buds, and of emitting fibrous roots; and when it is detached from the tree, the buds always spring near its upper end, and the roots near the opposite extremity, as in the cuttings above mentioned. The alburnum of the root is also similar to that of other parts of the tree, except that it is more porous, probably owing to the presence of abundant moisture during the period in which it is deposited†. And possibly the same cause may retain the wood of the root permanently in the state of alburnum; for I have shown, in

* Philosophical Transactions for 1805.

† Ibid. for 1801.

a former memoir, that if the mould be taken away, so that the parts of the larger roots, which adjoin the trunk, be exposed to the air, such parts are subsequently found to contain much heart wood*.

I would wish the preceding observations to be considered as extending to trees only, and exclusive of the palm tribe; but I believe they are nevertheless generally applicable to perennial herbaceous plants, and that the buds and fibrous roots of these originate from substances which correspond with the alburnum and bark of trees. It is obvious, that the roots which bulbs emit in the spring, are generated by the sap which descends from the bulb, when that retains its natural position; and such tuberous-rooted plants as the potatoe offer rather a seeming than a real obstacle to the hypothesis I am endeavouring to establish. The buds of these are generally formed beneath the soil; but I have shown, in a former memoir, that the buds on every part of the stem may be made to generate tubers, which are similar to those usually formed beneath the soil; and I have subsequently seen, in many instances, such emitted by a reproduced bud, without the calyx of a blossom, which had failed to produce fruit; but I have never, under any circumstances, been able to obtain tubers from the fibrous roots of the plant.

The tube therefore appears to differ little from a branch; which has dilated instead of extending itself, except that it becomes capable of retaining life during a longer period; and when I have laboured through a whole summer to counteract the natural habits of the plant, a profusion of blossoms has in many instances sprung from the buds of a tuber.

The runners also, which, according to the natural habit of the plant, give existence to the tubers beneath the soil, are very similar in organization to the stem of the plant, and readily emit leaves, and become converted into perfect stems in a few days, if the current of ascending sap be diverted into them; and the mode in which the tuber is formed above and beneath the soil is precisely the same. And when the sap, which has been deposited at rest during the autumn and

* *Philosophical Transactions for 1801.*

winter, is again called into action to feed the buds, which elongate into parts of the stems of the future plants in the spring, fibrous roots are emitted from the bases of these stems, whilst buds are generated at the opposite extremities, as in the cases I have mentioned respecting trees.

Many naturalists* have supposed the fibrous roots of all plants to be of annual duration only; and those of bulbous- and tuberous-rooted plants certainly are so: as in these Nature has provided a distinct reservoir for the sap which is to form the first leaves and fibrous roots of the succeeding season; but the organization of trees is very different, and the alburnum and bark of the roots and stems of these are the reservoirs of their sap during the winter †. When, however, the fibrous roots of trees are crowded together in a garden-pot, they are often found lifeless in the succeeding spring; but I have not observed the same mortality to occur, in any degree, in the roots of trees when growing, under favourable circumstances, in their natural situation.

I am prepared to offer some observations on the causes which direct the roots of plants in search of proper nutriment, and which occasion the root of the same plant to assume different forms under different circumstances; but I propose to make those observations the subject of a future communication.

I am, my dear sir,
with great respect, your much obliged, &c. &c.

THOMAS AND. KNIGHT.

Elton, Dec. 22, 1808.

VI. *Analysis of the Mécanique Céleste of M. LA PLACE.*

By M. BIOT.

[Continued from vol. xxxiii. p. 476.]

THE author is afterwards occupied with the determination of the motions of the heavenly bodies by successive approximations. In the theory of these motions the action of the perturbing forces only obliges us to add some small terms

* M. Mirbel's *Traité d'Anatomie*, &c. &c. Dr. Smith's Introduction to Botany.

† Philosophical Transactions for 1805.

to the differential equations of the elliptic motion : the author consequently examines what are the changes to which it is necessary to subject the integrals of the differential equations, in order to have those of the same equations augmented by certain terms. The analysis which he uses gives these integrals in a simple and exact manner when the proposed equations are linear, and furnishes in general a method of obtaining them by approximation : we may attain the same object by the method of successive substitutions. The author details this process, which has the inconvenience of introducing arcs of a circle, out of the periodical signs in the approximate integral, even when they are not to be found in the exact integral ; and this circumstance takes place when this last should contain, under the periodical signs, the very small coefficients, according to the powers of which the approximate integral is ordered : these arcs of a circle being susceptible of an indefinite increase would at length render the approximate integrals defective ; and as it is of importance that these integrals may embrace past and future ages, it is necessary to repass from these arcs of a circle to the functions which produce them by their development into series. In order to attain this object, the author gives a method applicable to any given number of differential equations ; he shows afterwards that the integrals of the differential equations preserve the same form, when these equations are increased by certain terms ; and from this he deduces the means of obtaining, among the arbitrary constant quantities, the conditions relative to this last supposition : he afterwards shows the utility of the variation of the constant arbitrary quantities for facilitating the approximate integration of the equations in certain cases.

The author applies the preceding methods to the perturbations of the celestial motions ; he obtains at first under a finite form the perturbations of the motion in longitude, latitude, and those of the radius vector of the orbit : he afterwards takes up the subject of the important problem which has for its object the development of perturbations in convergent series of the sine and cosine of angles increasing proportionally to the time. To obtain this, he first gives a very

simple method, by which we immediately obtain the differential equations which determine the perturbations ordered according to the powers and to the products of the excentricities of the inclinations of the orbits. This method consists in supposing the radius vector of the disturbed orbit expressed by a function of the same form as that of the elliptic orbit; the quantity which enters into this function is then found, given as in the elliptic motion by a linear differential equation of the second order with constant coefficients, increased by a last term depending on the action of the disturbing forces; circumstances which permit us to apply to this equation the methods of integration previously detailed: in the latter, regard is had only to the first power of the disturbing force. It is necessary, for what precedes, to develop a certain function of the masses and of the mutual distances of the bodies of the system in a converging series of the sines and cosines of angles increasing proportionally to the time. The author gives the method of attaining this, and employs, in this calculation, in a very elegant manner, the characteristic of the integrals of finite differences: this permits him to express with much simplicity the development sought, and the product of this development by the sine or cosine of any angle. According to what precedes, he determines the perturbations of motion in longitude, latitude, and those of the radius vector of the orbit, carrying his precision as far as quantities of the order of the eccentricities and of the inclinations of the orbits, and demonstrates the convergency of these results, whatever be the ratio of the distances of the planets which we consider to the sun; a circumstance the more important to observe, since otherwise it would have been impossible to express analytically the reciprocal perturbations of the planets, with respect to which the relations of these distances approach to unity: he afterwards collects these results which contain the whole theory of the planets, when we neglect the squares and products of the eccentricities, and of the inclinations of the orbits, which is most frequently permitted. After having shown how we could, if it were necessary, obtain a greater approximation, he gives the means of estimating the degree of precision of the

the different terms of which these formulæ are composed, and shows that we may easily extend them to the case in which the number of the disturbing masses is given.

The formulæ which give the disturbed motion containing in some of their terms the time without periodical signs, the author employs the method described above to make these terms disappear. This process leads to differential equations among the constant arbitrary quantities of the problem which are here the elements of the elliptic motion; we obtain by this means the variations which these elements undergo in consequence of the action of the disturbing masses, at least so far as we neglect the second powers of these masses, and those of the eccentricities and inclinations of the orbits. The first property which this analysis displays, is, that the transverse axes of the orbits and the mean motions are unalterable; but the expression of the longitude from which we draw this result being only approximate, it is important to examine the nature of the terms which might be there introduced by successive approximations; for, if there were any which were proportional to the square of the time, the preceding property would cease to take place, and the transverse axes and the mean motions might be indefinitely altered. The author shows, that if we regard only the first power of the disturbing masses, however far in other respects we may extend the approximation with respect to the eccentricities and inclinations, the expression of the longitude will never contain any similar terms, at least while the mean motions of the bodies of the system are incommensurable among each other, which is the case with the solar system; whence it results, that by confining ourselves to the first powers of the disturbing masses, the transverse axes of the orbits are constant, and the mean motions uniform. The author afterwards integrates the differential equations which determine the variations of the other elliptic elements; he discusses their extent, and shows that the solar system can only oscillate around a mean state of ellipticity and of inclination, from which it wanders little: hence it follows, that the orbits of the planets and satellites never have been, and never will be, considerably eccentric;

nor inclined to each other, at least if we regard only the mutual action of these bodies. The variations determined by the preceding analysis, taking place with great slowness, have been named *secular*; and we may, during a long interval, suppose them proportional to the time: the author gives the method of obtaining them under that form, which is useful for astronomical purposes.

These inquiries make known some relations among the elements of the orbits which are only approximate: the author develops those which take place in general, whatever may be the eccentricities and the inclinations: he afterwards gives the necessary formulæ for determining, with respect to the solar system, the position of the invariable plane upon which the sum of the areas described by the projections of the radii vectores of the bodies of the system, multiplied respectively by the masses of these bodies, is a maximum. The research of this plane becomes very important, on account of the proper motions of the stars and of the ecliptic; but it requires that we should know the masses of the comets, and the elements of their orbits: happily, these masses appearing to be very small, we may, without any perceptible error, neglect their action on the planets: considering then the motion of two orbits inclined one to the other by any given angle, the author shows that, independently of every extraneous cause, the two orbits will always cut the invariable plane relative to their system in the same straight line, the ascending node of the one coinciding with the descending node of the other; and he gives, upon the supposition of very small inclinations, the expression of the motion of this intersection.

The preceding method only giving the inequalities independent of the mutual configuration of the bodies of the system, the author resumes this problem by a different process; he infers from analytical considerations detailed above, that the disturbed motion of the celestial bodies may be referred to the laws of elliptic motion, supposing the elements of this motion variable; he shows that these results may also be drawn immediately from the consideration of elliptic motion, regarding the disturbed planet, as oscillating in a very
small

small orb around a fictitious planet, moved according to the laws of elliptic motion, in an ellipsis, the elements of which vary by insensible shades: hence are deduced with facility, the differential equations which determine these variations. By applying these results to the case of orbits eccentric in a small degree, and little inclined towards each other, and neglecting the second powers of the perturbing masses, we see in the first place that the transverse axes and the mean motions are only subjected to periodical variations depending upon the mutual configuration of the bodies of the system, and thereby even not very extensive: hence it follows that by neglecting these quantities, the major axes of the orbits are constant, and the mean motions are uniform; a result previously found by a different method. This property only takes place when the mean motions of the bodies of the system are incommensurable among each other, which is the case with the planets: if, with respect to some of these bodies, very little is required in order to fulfil this condition, the elliptic elements, and particularly the mean longitude which depends upon two integrations, acquire in certain terms very large divisions, which introduce there some very perceptible inequalities. The author gives the method of determining those which affect the mean longitude, and he shows that when there are inequalities of this kind, which the action of one of the bodies of the system produces upon the mean motion of another, it is easy to deduce those which the action of the second body produces on the mean motion of the first, and he proves that these inequalities are affected by contrary signs, and reciprocal to the products of the masses of bodies by the square roots of the major axes of their orbits. The illustrious author of this work has been the first to demonstrate that to a similar cause is owing the acceleration of the mean motion of Jupiter, and the retardation of that of Saturn. (*Mémoires de l'Académie*, 1784-85).

The author afterwards examines the case in which the most perceptible inequalities of the mean motion are only to be met with among the terms of the order of the square of the *perturbatrix* masses: this singular circumstance takes place in the system of the satellites of Jupiter, and it depends
upon

upon the relations which observations point out between the mean motions of the three first among each other. The author develops at proper length this important point of the system of the world; and from it he infers that *the mean motion of the first satellite, minus thrice that of the second, plus twice that of the third, is exactly and constantly equal to nothing, and that the mean longitude of the first satellite minus thrice that of the second, plus thrice that of the third, is exactly and constantly equal to two right angles.* These elegant theorems, which would of themselves be sufficient to immortalize their author, have been presented for the first time to geometricians and astronomers, in the Memoirs above quoted.

The author afterwards develops the differential equations which determine the variations of the other elements of the orbit: he shows that the values of the unknown quantities which they contain are composed of two parts; the one, depending upon the mutual configuration of the bodies of the system, contains the variations called *periodic*; the other, independent of this configuration, contains the variations called *secular*. The author gives a very simple method of obtaining the first part; and as to the second, he proves that it is given by the same differential equations deprived of their last terms; a circumstance which refers them to those which he had formerly treated of at full length, by the first method of approximation which we have mentioned.

We have said that the relations of the mean motions may introduce, in the expression of the mean longitude, a sensible inequality among the terms depending upon the second power of the disturbing masses. The author examines the influence of these same relations upon the other elements, and he determines the inequalities resulting from them; he establishes the very simple relations which connect these inequalities with those of the mean motion; he discusses the variations to which the same cause subjects the expressions of the latitude above a fixed plane a little inclined to the orbit; he shows how by means of these results we obtain the values of the latitude, longitude, and of the radius vector of the disturbed orbit, variable quantities which determine
the

the position of the celestial bodies. In this manner terminates the second book: extremely remarkable from the importance of the subject, the elegance of the methods, and the simplicity of the details; valuable advantages which are principally felt in the inquiry into the inequalities depending upon the relations of the mean motions. Geometricians know that it is to the author of this work we are indebted for almost the whole of this theory.

END OF BOOK SECOND.

[To be continued.]

VII. *Account of the Dissection of a Human Fœtus, in which the Circulation of the Blood was carried on without a Heart.* By Mr. B. C. BRODIE. Communicated by EVERARD HOME, Esq., F.R.S.*

AN opportunity lately occurred to me of examining a human fœtus, in which the heart was wanting, and the circulation of the blood was carried on by the action of the vessels only. There have been some other instances of this remarkable deviation from the natural structure; but in that to which I allude the growth of the child had been natural, and it differed much less from the natural formation than in any of those which are on record, and I have therefore been induced to draw up the following account of it.

A woman was delivered of twins in the beginning of the seventh month of pregnancy. There was a placenta with two umbilical chords, which had their origin about three inches distant from each other. The placenta was not preserved; but Mr. Adams, who attended the mother in her lying-in, observed nothing unusual in its appearance. Both fœtuses were born dead. They were nearly of the same size. One of them in no respect differed from the ordinary formation; the other had an unusual appearance, and Mr. Adams thought it deserving of examination. Through Dr. Hooper it was put into my hands for this purpose.

The fœtus measured thirteen inches from the summit of

* From Philosophical Transactions for 1809, Part I.

the cranium to the feet. The thorax and abdomen were surrounded by a large shapeless mass, which concealed the form of the whole upper part of the body. This mass proved to be the integuments covering the posterior part of the neck and thorax, distended with a watery fluid about three pints in quantity, contained in two cysts lined by a smooth membrane. When the fluid was evacuated, and the cysts allowed to collapse, the fœtus had nearly the natural form. Its extremities had nearly the usual appearance, except that on the right hand there was no thumb; on the left hand there was no thumb also, and only a single finger. There were three toes on the right foot, and four toes on the left foot. The external nostrils consisted only of two folds of skin, under each of which was the orifice of an internal nostril, but pervious only for about half an inch. There was a hare lip, and a cleft in the bony palate extending one-third of an inch backwards.

On dissection, the cranium was found somewhat compressed by the fluid contained in the cyst behind it. The brain itself was too putrid for accurate examination, but it was of nearly the natural size, and nothing unusual was observed in it. The membranes had the natural appearance, and the nerves appeared to go off from the brain and spinal marrow nearly as usual.

In the thorax there was no heart, thymus gland, or pleura. The trachea was situated immediately behind the sternum. It had its natural appearance, and divided as usual into the two bronchia. The latter terminated in the lungs, which consisted of two rounded bodies, not more than one-third of an inch in diameter, having a smooth external surface, and composed internally of a dense cellular substance. The œsophagus had the usual situation, but it terminated in a cul-de-sac at the lower part of the thorax. The rest of the thorax was filled with a dense cellular substance; and in place of the diaphragm, there was a membranous septum between it and the cavity of the abdomen.

In the abdomen, the stomach had no cardiac orifice. The intestine was attached to the mesentery in the usual way; but it was proportionably shorter than natural. There was

an imperfect cœcum, but the colon was not distinguished by any difference of structure or appearance from the rest of the intestine. The rectum had its usual situation in the pelvis. The spleen and renal capsules were small; the kidneys, bladder, penis, and testicles had the usual appearance. The abdomen was lined by peritonæum, but there was no omentum. The liver and gall-bladder were wanting.

As there was no heart, it became an object of importance to ascertain the exact nature of the circulation: for this purpose the blood-vessels were traced with attention.

The umbilical chord consisted of two vessels only: one of these was larger than the other, and its coats resembled those of a vein, while those of the smaller vessel were thick and elastic, like those of an artery. Both of these vessels entered the navel of the child. The artery passed to the left groin by the side of the urachus, occupying the usual situation of the left umbilical artery. Here it gave off the external and internal iliac arteries of the left side, and was then continued upwards on the fore-part of the spine forming the aorta. From the aorta arose the common trunk of the right iliac artery, and the branches to the viscera and parietes of the thorax and abdomen. At the upper part of the thorax it sent off the two subclavian, and afterwards divided into the two carotid arteries, without forming an arch. The veins corresponding to these arteries terminated in the vena cava, which was situated on the anterior part of the spine before the aorta, and passed downwards before the right kidney to the right groin. Here it became reflected upwards by the side of the urachus to the navel, and was continued into the larger vessel or vein of the chord.

It appears therefore, that, in this fœtus, not only the heart was wanting, but there was no communication of any kind between the trunks of the venous and arterial systems, as in the natural fœtus, where there is a heart. The only communication between the two sets of vessels, was by means of the capillary branches anastomosing as usual in the fœtus and in the placenta. The blood must have been propelled from the placenta to the child through the artery of the chord, and must have been returned to the placenta by
means

means of the vein, so that the placenta must have been at once the source and the termination of the circulation, and the blood must have been propelled by the action of the vessels only.

It is to be understood, that the circulation in the fœtus receives no propelling power from the action of the heart and arteries of the mother. This, although perfectly known to anatomists, it is proper to mention, as it may not be equally known to all the members of this Society.

It appears extraordinary, that under these circumstances, notwithstanding the circulation through the placenta must have been more languid than is natural, that organ should nevertheless have been capable of exercising its proper functions, so as to produce those changes on the blood which are necessary for the maintenance of fœtal life. This may be explained by considering that in the natural fœtus the umbilical arteries are branches of the general arterial system, and only a portion of the blood of the child is sent to the placenta; whereas, in the fœtus which I have described, the trunk of the vena cava was continued into the vein of the chord, and the whole of the venous blood circulated through the placenta, and was exposed to the influence of the arterial blood of the mother.

But the most interesting circumstance which we learn from this examination is, that the circulation not only can be carried on without a heart, but that a child so circumstanced can be maintained in its growth, so as to attain the same size as a fœtus which is possessed of that organ. This fact is contrary to what prior experience has led us to expect, as will appear from the following abstract of the authenticated cases of this species of malformation, which we find on record.

A monster, in which there was no heart, is described by M. Mery*. There were twins, one of which was well formed, and of the usual size of a six months child: the size of the other was not mentioned, so that no comparison could be made between them. In the latter, the head, neck,

* *Histoire de l'Académie Royale des Sciences*, 1720.

and upper extremities were wanting. There were no vestiges of a brain, nor was there any liver. The dissection of the blood-vessels does not appear to have been very accurately made; but, from the general account, I should suppose that the circulation did not materially differ from that of the fœtus which I have described.

Another instance of this kind is described by M. Winslow*. This was also a twin, only seven inches in length. The age and size of the other child are not mentioned. In this instance there was no head, nor any vestige of brain. There were no lungs, liver, stomach, nor spleen, and only a small portion of intestine. The arterial system is described as being complete, communicating with the placenta by the umbilical vein opening into the aorta, and the umbilical arteries arising nearly as usual. In this instance there was a circle of vessels formed by the arteries only, for M. Winslow expressly states, that there were no veins; and however extraordinary this may appear, we cannot be otherwise than cautious in denying an observation made by an anatomist so remarkable for his extreme accuracy and minuteness.

Dr. Le Cat, of Rouen, states another case of twins † born at the end of the ninth month of pregnancy. One of them was a well-formed child of the usual size; but the other was only twelve inches and a half in length. The head of the latter was very imperfect, and there was only a very minute portion of brain. The heart, lungs, liver, stomach, and spleen were entirely wanting, and there was only a small portion of intestine. The arterial system was perfect; the umbilical vein terminated in the aorta, and the umbilical arteries had their origin from the internal iliac, as usual. There is, however, an obscurity in the account of the circulation, as it is stated that there were veins, but they were not traced, nor was any communication made out between them and the arteries, or the vessels of the chord.

Dr. Clarke ‡ has given an account of a case, in which a woman, after a natural labour, was delivered of a healthy child, and also of a substance covered by common integu-

* *Histoire de l'Académie Royale des Sciences*, 1740.

† *Philosophical Transactions* for 1767.

‡ *Ibid.* for 1793.

ments, of an oval form, four inches in length, and having a separate navel string and placenta. In this substance there was one *os innominatum*; with a femur, tibia, and fibula: There were neither brain nor nerves; nor were there any viscera, except a small portion of intestine. The umbilical chord consisted of two vessels, an artery and a vein, both of which ramified in this substance and in the placenta.

In Dr. Hunter's anatomical collection, there are two specimens of monsters born without hearts. In both of them the whole upper part of the body was wanting; and in neither was the exact nature of the circulation ascertained.

In each of the instances which I have quoted, not only the heart was wanting, but the fœtus in other respects was so imperfect, that it could not be considered as any thing more than a mola, or an irregularly-formed living mass connected with the placenta. In particular, in all of them the brain, which may with justice be considered as affording the best distinction between a mola and a fœtus, was wanting; whereas in that which forms the subject of the present paper, the brain was nearly as large as usual, and in other respects the fœtus varied much less from the natural structure than in any former instance.

In the cases already on record, we have seen, that wherever the size of the monster was mentioned, it was much smaller than a natural fœtus. This would have led to the supposition, that a circulation, which was carried on by the action of the vessels only, was incapable of maintaining the natural growth of a child, had it not been found that the fœtus, which I have described, though the heart was wanting, was fully equal in size to a fœtus of the same age which was possessed of that organ.

It may be observed, that in all these cases, in which the heart was wanting, the liver was wanting also. It is probable, that the action of the vessels only, without the assistance of the heart, would have been insufficient to propel the blood through the circulation of the liver, which is so extensive in the natural fœtus.

VIII. *Geological Observations, on the Excavations of Valleys, the supposed Existence of numerous Lakes. at former Periods where Valleys now exist, which the Streams flowing through them are said to have broken down, &c. : in Reply to Mr. JOHN CARR'S Letter in the last Number, p. 452. By Mr. JOHN FAREY.*

TO MR. TILLOCH,—SIR,

BEFORE epithets so harsh, as “most lame and impotent conclusion!” are applied to the words of any writer, it behoves him who uses them, to endeavour fully to understand the words commented upon; but above all, to take care and quote them faithfully. Having stated, page 262 of your last volume, that I had for weeks and months together, daily-contemplated valleys, “wonderfully distributed over the whole surface of large districts, effecting a descending outlet or drainage to *every part thereof* :” I cannot pass over as immaterial, the alteration which Mr. Carr has made in substituting “any” in place of the words “every part thereof,” when he quotes them (at page 452) for the purpose of “judging” so hastily on my subsequent conclusions: because, by marking those words *in italics*, I expressly intended, to exclude and deny the assumption which he makes just after, of a succession of “alluvial flats,” existing generally in valleys, the seats of a former chain of lakes; the same having been some years ago the opinion adopted (and it is a very old one, as I have before observed,) by an able and scientific friend of mine, founded on the appearances of the gravel of one particular spot, and rocky cliffs below, in a long vale; on which, he and I have held frequent discussions, without any conviction being brought to my mind, that a lake ever did exist in the place alluded to, which is near to Leighton Busard in Bedfordshire: the opinion having, however, been adopted, in the instance alluded to, by one, for whose abilities and talents I have the highest respect, the subject has constantly recurred to me since, without my having ever seen any case, which could establish the probability even, of the previous existence of a lake.

When I wrote last from Sheffield, a most material part,
 Vol. 34. No. 135. July 1809. D at

at the northern end of the district which I am surveying, had not then been seen by me : but having since visited every part of the Woodlands and been frequently full in view of the great town whence Mr. Carr dates his letters, when in the neighbourhood of Ashton, Duckenfield, Hyde-Chapel, Werneth-Low, &c., I can now speak as confidently of numerous valleys which discharge into the river Mersey containing the "alluvial flats" of no ancient lakes, as I can of all others which I have yet any where seen.

Not having had an opportunity yet, of seeing the lake districts of Westmorland, Cumberland, &c., I will say nothing of existing lakes, but doubtless, from none of these giving way, and becoming valleys, common as Mr. C. supposes such events to have been, the circumstances between their situation and ordinary valleys, must be essentially different, according to his own principles, page 386.

The remark which I made (page 445) on the very inconsiderable quantity of *native* or local alluvia, to be found on the eastern side of the grand ridge of the island, applies with all its force to the western side of the same ridge. Here a considerable quantity of *foreign* alluvial matters is deposited, consisting principally of a reddish earthy mixture called Marl*, very unlike anything which the strata of these parts produce, and containing numerous and large highly rounded boulders of *granite* of different sorts, with other foreign boulders, principally of a blue colour, and most of which seem to be venigenous fossils, and not fragments of any rock, the granites excepted : these too are as often lodged on the tops of high hills, as they are in the valleys ; of which Werneth-Low near Hyde-Chapel is an instance, the very top of which hill exhibits numerous and very large ancient pits, whence our forefathers took this foreign alluvia for marling of their lands.

At Hyde Lane, which is but a short ride from Manchester, Mr. Carr may have the opportunity of seeing, perhaps, the finest instance of an excavated valley, (Godley Brook,) and of a denudated surface, which is any where to be seen

* Which seems the same as sir John Stanley has described, in H. Holland's Agricultural Report on Cheshire, p. 649.

which the vales are excavated; of which the numerous and highly curious deep dry vales, branching from the Dove and Wye rivers in Derbyshire, are well known examples.

It is by no means a general truth, that if the matters excavated from the strata to form valleys were replaced (page 454), "there would still be a sufficient fall in the country for the streams to flow *the same way*:" the instances are very numerous to the contrary. If, for instance, Mr. C. will take the trouble, to inspect the course of the Goyte rivers on the S.W. of New-Mills in Glossop, of the Derwent river on the S.W. of Matlock church, and many others, he will be forced also to admit, that excavated vales do not *always* follow the lowest ground.

It is neither true, that "*in every instance* the angle of intersection of valleys and streams is acute above and obtuse below;" nor that "two streams *invariably* meet on precisely the same level:" the exceptions are numerous to both of these positions, unless indeed, some quibble or play upon the words be intended therein.

Since, sir, Mr. Carr and myself are at issue, upon so many of the *facts respecting valleys*, particularly that, where he says (page 457) "a proper examination of the soil below every valley will discover the very materials formerly brought down when the valley was excavating," it might appear as invidious as it is at present unnecessary, for me to enter into any examination of the defective reasonings, as I conceive them to be on some of the assumptions made by Mr. C.

I must, however, before I conclude, express my surprise, that a person who thought himself justified, in a competent knowledge of the facts respecting valleys, to write thus *confidently*, should have forgot, and not once have mentioned the *faults* or fissures, so universally met with in the strata, effecting their entire separation into fragments, and causing those great disarrangements of the several pieces or piles of strata, both as to their elevations and inclinations, which are commonly seen, since, the forms of valleys as well as hills, and of the surface in general, so eminently depend on them in most instances, but not perhaps in all.

The

The Map that I am preparing, which traces every stream and vale up to its very origin, and shows its connection with the hard and soft, and porous and water-tight strata, and with the principal faults and tilts of the same, in its vicinity, will, as I trust, somewhat elucidate this difficult subject: on which I much wish to hear the observations of others of your able correspondents, and am,

Sir, your obedient humble servant,

Ram's Head Inn, Disley, Cheshire,
July 15, 1809.

JOHN FAREY.

* * In our last vol. p. 263, line 1, *the bases* should have been *the bassets* of three or four different strata &c. *Basset, crop, &c.*, are mining terms for the out-burst or appearance of a stratum on the surface.

IX. *A numerical Table of elective Attractions; with Remarks on the Sequences of double Decompositions.* By THOMAS YOUNG, M.D. For. Sec. R.S.*

ATTEMPTS have been made, by several chemists, to obtain a series of numbers, capable of representing the mutual attractive forces of the component parts of different salts; but these attempts have hitherto been confined within narrow limits, and have indeed been so hastily abandoned, that some very important consequences, which necessarily follow from the general principle of a numerical representation, appear to have been entirely overlooked. It is not impossible, that there may be some cases, in which the presence of a fourth substance, besides the two ingredients of the salt, and the medium in which they are dissolved, may influence the precise force of their mutual attraction, either by affecting the solubility of the salt, or by some other unknown means, so that the number, naturally appropriate to the combination, may no longer correspond to its affections; but there is reason to think that such cases are rare; and when they occur, they may easily be noticed as exceptions to the general rules. It appears, therefore, that nearly all the phænomena of the mutual actions of a hundred different salts may be correctly represented by a hundred numbers, while, in the usual

* From Philosophical Transactions for 1809, Part I.

manner of relating every case as a different experiment, above two thousand separate articles would be required.

Having been engaged in the collection of a few of the principal facts relating to chemistry and pharmacy, I was induced to attempt the investigation of a series of these numbers; and I have succeeded, not without some difficulty, in obtaining such as appear to agree sufficiently well with all the cases of double decompositions which are fully established, the exceptions not exceeding twenty, out of about twelve hundred cases enumerated by Fourcroy. The same numbers agree in general with the order of simple elective attractions, as usually laid down by chemical authors; but it was of so much less importance to accommodate them to these, that I have not been very solicitous to avoid a few inconsistencies in this respect, especially as many of the bases of the calculation remain uncertain, and as the common tables of simple elective attractions are certainly imperfect, if they are considered as indicating the order of the independent attractive forces of the substances concerned. Although it cannot be expected that these numbers should be accurate measures of the forces which they represent, yet they may be supposed to be tolerable approximations to such measures; at least, if any two of them are nearly in the true proportion, it is probable that the rest cannot deviate very far from it: thus, if the attractive force of the phosphoric acid for potash is about eight tenths of that of the sulfuric acid of barita, that of the phosphoric acid for barita must be about nine tenths as great; but they are calculated only to agree with a certain number of phenomena, and will probably require many alterations, as well as additions, when all other similar phenomena shall have been accurately investigated.

There is, however, a method of representing the facts, which have served as the bases of the determination, independently of any hypothesis, and without being liable to the contingent necessity of any future alteration, in order to make room for the introduction of the affections of other substances; and this method enables us also to compare,
upon

upon general principles, a multitude of scattered phenomena, and to reject many which have been mentioned as probable, though doubtful, with the omission of a very few only which have been stated as ascertained. This arrangement simply depends on the supposition, that the attractive force, which tends to unite any two substances, may always be represented by a certain constant quantity.

From this principle it may be inferred, in the first place, that there must be a sequence in the simple elective attractions. For example, there must be an error in the common tables of elective attractions, in which magnesia stands above ammonia under the sulfuric acid, and below it under the phosphoric, and the phosphoric acid stands above the sulfuric under magnesia, and below it under ammonia, since such an arrangement implies, that the order of the attractive forces is this; phosphate of magnesia, sulfate of magnesia, sulfate of ammonia, phosphate of ammonia, and again phosphate of magnesia; which forms a circle, and not a sequence. We must therefore either place magnesia above ammonia under the phosphoric acid, or the phosphoric acid below the sulfuric under magnesia; or we must abandon the principle of a numerical representation in this particular case.

In the second place, there must be an agreement between the simple and double elective attractions. Thus, if the fluoric acid stands above the nitric under barita, and below it under lime, the fluuate of barita cannot decompose the nitrate of lime, since the previous attractions of these two salts are respectively greater, than the divellent attractions of the nitrate of barita and the fluuate of lime. Probably, therefore, we ought to place the fluoric acid below the nitric under barita; and we may suppose, that when the fluoric acid has appeared to form a precipitate with the nitrate of barita, there has been some fallacy in the experiment.

The third proposition is somewhat less obvious, but perhaps of greater utility: there must be a continued sequence in the order of double elective attractions; that is, between any two acids, we may place the different bases in such an order, that any two salts, resulting from their union, shall

always decompose each other, unless each acid be united to the base nearest to it: for example, sulfuric acid, barita, potass, soda, ammonia, strontia, magnesia, glycina, alumina, zirconia, lime, phosphoric acid. The sulfate of potass decomposes the phosphate of barita, because the difference of the attractions of barita for the sulfuric and phosphoric acids is greater than the difference of the similar attractions of potass; and in the same manner the difference of the attractions of potass is greater than that of the attractions of soda; consequently the difference of the attractions of barita must be much greater than that of the attractions of soda, and the sulfate of soda must decompose the phosphate of barita: and in the same manner it may be shown, that each base must preserve its relations of priority or posteriority to every other in the series. It is also obvious that, for similar reasons, the acids may be arranged in a continued sequence between the different bases; and when all the decompositions of a certain number of salts have been investigated, we may form two corresponding tables, one of the sequences of the bases with the acids, and another of those of the acids with the different bases; and if either or both of the tables are imperfect, their deficiencies may often be supplied, and their errors corrected, by a repeated comparison with each other.

In forming tables of this kind from the cases collected by Fourcroy, I have been obliged to reject some facts, which were evidently contradictory to others, and these I have not thought it necessary to mention: a few, which are positively related, and which are only inconsistent with the principle of numerical representation, I have mentioned in notes; but many others, which have been stated as merely probable, I have omitted without any notice. In the table of simple elective attractions, I have retained the usual order of the different substances; inserting again in parentheses such of them as require to be transposed, in order to avoid inconsequences in the simple attractions: I have attached to each combination marked with an asterisc the number deduced from the double decompositions, as expressive of its attractive force; and where the number is inconsistent with the corrected

corrected order of the simple elective attractions, I have also inclosed it in a parenthesis. Such an apparent inconsistency may perhaps in some cases be unavoidable, as it is possible that the different proportions of the masses concerned, in the operations of simple and compound decomposition, may sometimes cause a real difference in the comparative magnitude of the attractive forces. Those numbers, to which no asterisc is affixed, are merely inserted by interpolation, and they can only be so far employed for determining the mutual actions of the salts to which they belong, as the results which they indicate would follow from the comparison of any other numbers, intermediate to the nearest of those, which are more correctly determined. I have not been able to obtain a sufficient number of facts relating to the metallic salts, to enable me to comprehend many of them in the tables.

It has been usual to distinguish the attractions, which produce the double decompositions of salts, into necessary and superfluous attractions; but the distinction is neither very accurate, nor very important: they might be still further divided, accordingly as two, three, or the whole of the four ingredients concerned are capable of simply decomposing the salt in which they are not contained; and if two, accordingly as they are previously united or separate; such divisions would however merely tend to divert the attention from the natural operation of the joint forces concerned.

It appears to be not improbable, that the attractive force of any two substances might, in many cases, be expressed by the quotient of two numbers appropriate to the substances, or rather by the excess of that quotient above unity; thus the attractive force of many of the acids for the three principal alkalies might probably be correctly represented in this manner; and where the order of attractions is different, perhaps the addition of a second, or of a second and third quotient, derived from a different series of numbers, would afford an accurate determination of the relative force of attraction, which would always be the weaker, as the two substances concerned stood nearer to each other in these orders

orders of numbers ; so that, by affixing, to each simple substance, two, three, or at most four numbers only, its attractive powers might be expressed in the shortest and most general manner.

I have thought it necessary to make some alterations in the orthography generally adopted by chemists, not from a want of deference to their individual authority, but because it appears to me that there are certain rules of etymology, which no modern author has a right to set aside. According to the orthography universally established throughout the language, without any material exceptions, our mode of writing Greek words is always borrowed from the Romans, whose alphabet we have adopted : thus the Greek vowel Υ , when alone, is always expressed in Latin and in English by Y, and the Greek diphthong OY by U, the Romans having no such diphthong as OU or OY. The French have sometimes deviated from this rule; and if it were excusable for any, it would be for them, since their *u* and *ou* are pronounced exactly as the Υ and OY of the Greeks probably were : but we have no such excuse. Thus the French have used the term *acoustique*, which some English authors have converted into "acoustics;" our anatomists, however, speak, much more correctly, of the "acoustic" nerve. Instead of glucine, we ought certainly, for a similar reason, to write glycine; or glycina, if the names of the earths are to end in *a*. Barytes, as a single Greek word, means weight, and must be pronounced bárytes; but as the name of a stone, accented on the second syllable, it must be written barites; and the pure earth may properly be called barita. Ytria I have altered to itria, because no Latin word begins with a Y.

Table of the Sequences of the Bases with the different Acids.

In all mixtures of the aqueous solutions of two salts, each acid remains united to the base which stands nearest to it in this table.

SULFURIC ACID.

Barita	Barita	Barita	Barita	Barita	Barita	Barita	Barita	Barita	Barita	Barita	Barita	Lead
Strontia	Potass	Potass	Potass	Potass	Potass	Potass	Potass	Potass	Potass	Potass	Potass	Mercury
Lime	Soda	Soda	Soda	Soda	Soda	Soda	Soda	Soda	Soda	Soda	Soda	Iron
(Silver?)	Ammonia	Ammonia	Ammonia	Ammonia	Ammonia	Ammonia	Ammonia	Ammonia	Ammonia	Ammonia	Ammonia	Potass
(Mercury?)	Strontia	Strontia	Strontia	Strontia	Strontia	Strontia	Strontia	Strontia	Strontia	Strontia	Strontia	Soda
Potass	Magnesia (3)	Magnesia (3)	Magnesia (4)	Magnesia (4)	Magnesia (5)	Magnesia (5)	Magnesia (6)	Magnesia (6)	Magnesia (6)	Magnesia (6)	Magnesia (6)	Magnesia
Soda	Glycina	Glycina	Glycina	Glycina	Glycina	Glycina	Glycina	Glycina	Glycina	Glycina	Glycina	Glycina
Zinc	Alumina	Alumina	Alumina	Alumina	Alumina	Alumina	Alumina	Alumina	Alumina	Alumina	Alumina	Lead
Iron	Zirconia	Zirconia	Zirconia	Zirconia	Zirconia	Zirconia	Zirconia	Zirconia	Zirconia	Zirconia	Zirconia	Zinc
Zinc	Lime	Lime	Lime	Lime	Lime	Lime	Lime	Lime	Lime	Lime	Lime	Copper
Copper	Glycina	Glycina	Glycina	Glycina	Glycina	Glycina	Glycina	Glycina	Glycina	Glycina	Glycina	Copper
Magnesia	Alumina (2)	Alumina (2)	Alumina (2)	Alumina (2)	Alumina (2)	Alumina (2)	Alumina (2)	Alumina (2)	Alumina (2)	Alumina (2)	Alumina (2)	
Ammonia (1)	Zirconia	Zirconia	Zirconia	Zirconia	Zirconia	Zirconia	Zirconia	Zirconia	Zirconia	Zirconia	Zirconia	
Glycina	(Copper?)	(Copper?)	(Copper?)	(Copper?)	(Copper?)	(Copper?)	(Copper?)	(Copper?)	(Copper?)	(Copper?)	(Copper?)	
Alumina												
Zirconia												
NITRIC	MURIATIC	PHOSPHORIC	FLUORIC	SULFUROUS	BORACIC	CARBONIC	(NITROUS)	(PHOSPHOROUS)	(ACETIC)			

(1) Ammonia stands above magnesia when cold. (2) A triple salt is formed. (3) Perhaps magnesia ought to stand lower. (4) A compound salt is formed, and when hot, magnesia stands above ammonia. (5) Fourcroy says, that sulfate of strontia is decomposed by borate of ammonia. (6) With heat, ammonia stands below lime and magnesia.

NITRIC
ACID.

Barita	Potass	Barita	Potass	Barita (10)	Potass
Potass	Soda	Potass	Soda	Potass	Soda
Soda	Ammonia	Soda	Ammonia	Soda	Barita (10)
Strontia	Magnesia	Ammonia	Magnesia	Ammonia	Ammonia (7,11)
Lime	Glycina	Magnesia	Glycina	Magnesia	Magnesia (7)
Magnesia (7)	Alumina	Glycina	Alumina	Glycina	Strontia
Ammonia (1)	Zirconia (8)	Alumina	Zirconia	Alumina	Lime
Glycina	Barita	Zirconia	Barita	Zirconia	Glycina
Alumina	Strontia	Strontia (9)	Strontia	Strontia	Alumina
Zirconia	Lime	Lime	Lime	Lime	Zirconia
MURIATIC	PHOSPHORIC	FLUORIC	SULFUROUS	BORACIC	CARBONIC

(7) A triple salt is formed. (8) Fourcroy says, that the muriate of zirconia decomposes the phosphates of barita and strontia. (9) According to Fourcroy's account, the fluete of strontia decomposes the muriates of ammonia, and of all the bases below it; but he says in another part of the same volume, that the fluete of strontia is an unknown salt. (10) According to Fourcroy's account of these combinations, barita should stand immediately below ammonia in both of these columns. (11) With heat, the carbonate of lime decomposes the muriate of ammonia.

PHOSPHORIC ACID.

Barita	Lime	Barita	Potass	Barita
Lime	Barita	Lime	Soda	Lime
Potass	Potass	Potass	Barita	Potass
Soda	Soda	Soda	Lime (13)	Soda
Strontia	Strontia	Strontia	Strontia	Strontia
Magnesia	Magnesia	Ammonia (12)	Ammonia	Magnesia
Ammonia	Ammonia	Magnesia	Magnesia	Glycina ?
Glycina	Glycina	Glycina	Glycina	Alumina
Alumina	Alumina	Alumina	Alumina	Zirconia
Zirconia	Zirconia	Zirconia	Zirconia	
FLUORIC	SULFUROUS	BORACIC	CARBONIC	(PHOSPHOROUS)

(12) According to Fourcroy, the phosphate of ammonia decomposes the borate of magnesia. (13) Fourcroy says, that the carbonate of lime decomposes the phosphates of potass and of soda.

FLUORIC ACID.

Lime	Lime	Potass
Potass	Barita	Soda
Soda	Strontia	Lime
Magnesia	Potass	Barita
Ammonia	Soda	Strontia
Glycina	Ammonia	Ammonia (14)
Alumina	Magnesia	Magnesia
Zirconia	Glycina	Glycina
Strontia	Alumina	Alumina
Barita	Zirconia	Zirconia
SULFUROUS	BORACIC	CARBONIC.

(14) According to Fourcroy, the carbonate of ammonia decomposes the fluates of barita and strontia.

SULFUROUS ACID.			BORACIC ACID.	
Barita	Potass	Lime	Zirconia	Potass
Strontia	Soda	Strontia	Alumina	Soda
Potass	Barita (15)	Barita	Glycina	Lime
Soda	Strontia	Zirconia	Ammonia	Barita
Ammonia	Ammonia	Alumina	Magnesia	Strontia
Magnesia	Lime	Glycina	Strontia	Magnesia
Lime	Magnesia	Magnesia	Soda	Ammonia
Glycina	Glycina	Ammonia	Potass	Glycina
Alumina	Alumina	Soda	Barita	Alumina
Zirconia	Zirconia	Potass	Lime	Zirconia
BORACIC	CARBONIC	(NITROUS)	(PHOSPHOROUS?)	CARBONIC

(15) Fourcroy says, that the sulfite of barita decomposes the carbonate of ammonia.

Table of the Sequences of the Acids with different Bases.

	BARITA.			STRONTIA.				LIME.				POTASS SODA	MAG- NESIA.	
Sulfuric	S	C	S	S	C	S	P	S	C	P	P	P	MAGN. = AMM.	{ S B N C M P P F F SS SS S B N C M AN
Nitric	N	S	P	N	SS	P	S	P	P	F	F	F	GLYCINA	
Muriatic	M	P	SS	M	F	SS	SS	SS	F	B	B	SS	ALUMINA	
Phosphoric	SS	SS	N	SS	P	F	F	F	B	SS	C	S	ZIRCONIA	
Sulfurous	P	N	M	C	B	B	B	B	SS	S	SS	B	Each with every subsequent base in this order	
Fluoric	C	M	F	B	S	C	C	N	S	C	S	N		
Boracic	B	F	B	F	M	N	N	M	M	N	N	M		
Carbonic	F	B	C	P	N	M	M	C	N	M	M	C		
STRONTIA	LM	PT	MG	LM	PT	MG	AM	GL	PT	MG	AM	GL		
		SD	AM		SD			AL		SD		AL		
			GL					ZR				ZR		
			AL											
			ZR											

The comparative use of this table may be understood from an example: If we suppose that the nitrate of barita decomposes the borate of ammonia, we must place the boracic acid above the nitric, between barita and ammonia in this table, and consequently barita below ammonia, between the fluoric and boracic in the former: hence the boracic and fluoric acids must also be transposed between barita and strontia, and between barita and potass; or if we place the fluoric still higher than the boracic in the first instance, we must place barita below ammonia between the nitric and fluoric acids, where indeed it is not impossible that it ought to stand.

Numerical Table of elective Attractions.

BARITA.	STRONTIA.	POTASS.	SODA.	LIME.			
Sulfuric acid	1000*	Sulfuric acid	903*	Sulfuric acid	960		
Oxalic	950	Phosphoric	827*	894* 895*	Sulfuric	868*	
Succinic	930	Oxalic	825	812* 804*	Tartaric	867	
Fluoric		Tartaric	757	804* 797*	Succinic	866	
Phosphoric	906*	Fluoric		Phosphoric	601* 795*	Phosphoric	865*
Mucic	900	Nitric	754*	Suberic?	745 740	Mucic	860
Nitric	849*	Muriatic	748*	Fluoric	671* 666*	Nitric	741*
Muriatic	840*	(Succinic)	740	Oxalic	650 645	Muriatic	736*
Suberic	800	(Fluoric)	703*	Tartaric	616 611	Suberic	735
Citric		Succinic		Arsenic	614 609	Fluoric	734*
Tartaric	760	Citric?	618	Succinic	612 607	Arsenic	733 $\frac{1}{2}$
Arsenic	733 $\frac{1}{2}$	Lactic	603	Citric	610 605	Lactic	732
(Citric)	730	Sulfurous	527*	Lactic	609 604	Citric	731
Lactic	729	Acetic		Benzoic	608 603	Malic	700
(Fluoric)	706*	Arsenic	(733 $\frac{1}{2}$)	Sulfurous	485* 484*	Benzoic	590
Benzoic	597	Boracic	513*	Acetic	486 482	Acetic	
Acetic	594	(Acetic)	480	Mucic	484 480	Boracic	537*
Boracic	(515)*	Nitrous?	430	Boracic	482* 479*	Sulfurous	516*
Sulfurous	592*	Carbonic	419*	Nitrous	440 437	(Acetic)	470
Nitrous	450			Carbonic	306* 304*	Nitrous	425
Carbonic	440*			Prussic	300 298	Carbonic	423*
Prussic	400					Prussic	290

MAGNESIA.	AMMONIA.	GLYCINA?	ALUMINA.	ZIRCONIA?		
Oxalic acid	820	Sulfuric acid	808*	Sulfuric acid	719* 709*	700*
Phosphoric		Nitric	731*	Nitric	642* 634*	626*
Sulfuric	810*	Muriatic	729*	Muriatic	639* 632*	625*
(Phosphoric)	736*	Phosphoric	728*	Oxalic	600 594	589
Fluoric		Suberic?	720	Arsenic	580 575	570
Arsenic	733	Fluoric	613*	Suberic?	535 530	525
Mucic	732 $\frac{1}{2}$	Oxalic	611	Fluoric	534* 529*	524*
Succinic	732 $\frac{1}{4}$	Tartaric	609	Tartaric	520 515	510
Nitric	732*	Arsenic	607	Succinic	510 505	500
Muriatic	728*	Succinic	605	Mucic	425 420	415
Suberic?	700	Citric	603	Citric	415 410	405
(Fluoric)	620*	Lactic	601	Phosphoric	(649)* (642)*	(636)*
Tartaric	619	Benzoic	599	Lactic	410 405	400
Citric	615	Sulfurous	433*	Benzoic	400 395	390
Malic?	600?	Acetic	432	Acetic	395, 391	387
Lactic	575	Mucic	431	Boracic	388* 385*	382*
Benzoic	560	Boracic	430*	Sulfurous	355* 351*	347*
Acetic		Nitrous	400	Nitrous	340 338	332
Boracic	459*	Carbonic	339*	Carbonic	325* 323*	321*
Sulfurous	439*	Prussic	270	Prussic	260 254	250
(Acetic)	430					
Nitrous	410					
Carbonic	366*					
Prussic	250					

Acids.

SULFURIC.	NITRIC.	MURIATIC.	PHOSPHORIC.
Barita	1000*	Barita	849*
Strontia	903*	Potass	812*
Potass	894*	Soda	804*
Soda	885*	Strontia	754*
Lime	868*	Lime	741*
Magnesia	810*	Magnesia	732*
Ammonia	808*	Ammonia	731*
Glycina	715*	Glycina	642*
Itria	712	Alumina	634*
Alumina	709*	Zirconia	626*
Zirconia	709*		
		Barita	840*
		Potass	804*
		Soda	797*
		Strontia	748*
		Lime	736*
		Ammonia	729*
		Magnesia	726*
		Glycina	639*
		Alumina	632*
		Zirconia	626*
		Barita	906*
		Strontia	827*
		Lime	(865)*
		Potass	801*
		Soda	795*
		Ammonia	(728)*
		Magnesia	736*
		Glycina	614*
		Alumina	642*
		Zirconia	636*

FLUORIC.		OXALIC. - TARTARIC.		ARSENIC.		TUNGSTIC.	
Lime	734*	Lime	960 867	Lime	733 $\frac{1}{2}$	Lime	
Barita	706*	Barita	950 760	Barita	733 $\frac{1}{2}$	Barita	
Strontia	703*	Strontia	825 757	Strontia	783 $\frac{1}{2}$	Strontia	
Magnesia (620)*		Magnesia	820 618	Magnesia	733	Magnesia	
Potass	671*	Potass	650 616	Potass	614	Potass	
Soda	666*	Soda	645 611	Soda	609	Soda	
Ammonia	613*	Ammonia	611 609	Ammonia	607	Ammonia	
Glycina	534*	Glycina?	600 520	Glycina	580	Glycina	
Alumina	529*	Alumina	594 515	Alumina	575	Alumina	
Zirconia	524*	Zirconia?	588 510	Zirconia	570	Zirconia	

SUCCINIC.		SUBERIC.		CAMPHORIC.		CITRIC.	
Barita	930	Barita	800	Lime		Lime	731
Lime	866	Potass	745	Potass		Barita	730
Strontia?	740	Soda	740	Soda		Strontia	618
(Magnesia) 732 $\frac{1}{2}$		Lime	735	Barita		Magnesia	615
Potass	612	Ammonia	720	Ammonia		Potass	610
Soda	607	Magnesia	700	Glycina?		Soda	605
Ammonia	605	Glycina?	535?	Alumina		Ammonia	603
Magnesia		Alumina	530	Zirconia?		Glycina?	415?
Glycina?	510	Zirconia?	525?	Magnesia		Alumina	410
Alumina	505					Zirconia	405
Zirconia?	500						

LACTIC.		BENZOIC.		SULFUREOUS.		ACETIC.	
Barita	729	White oxide of arsenic		Barita	592*	Barita	594
Potass	609	Potass	608	Lime	516*	Potass	486
Soda	604	Soda	603	Potass	485*	Soda	482
Strontia	603	Ammonia	599	Soda	484*	Strontia	450
Lime (732)		Barita	597	Strontia (527)*		Lime	470
Ammonia	601	Lime	590	Magnesia	439*	Ammonia	432
Magnesia	575	Magnesia	560	Ammonia	433*	Magnesia	430
Metallic oxids		Glycina?	400?	Glycina	355*	Metallic oxids	
Glycina	410	Alumina	395	Alumina	351*	Glycina	395
Alumina	405	Zirconia?	390?	Zirconia	347*	Alumina	391
Zirconia	400					Zirconia	387

MERIC?		BORACIC.		NITROUS?		PROSEKORQUEL.	
Barita	900	Lime	537*	Barita	450	Lime	
Lime	860	Barita	515*	Potass	440	Barita	
Potass	484	Strontia	513*	Soda	437	Strontia	
Soda	480	Magnesia (459)*		Strontia	430	Potass	
Ammonia	431	Potass	482*	Lime	425	Soda	
Glycina	425	Soda	479*	Magnesia	410	Magnesia?	
Alumina	420	Ammonia	430*	Ammonia	400	Ammonia	
Zirconia	415	Glycina	388*	Glycina	340	Glycina	
		Alumina	386*	Alumina	336	Alumina	
		Zirconia	382*	Zirconia	332	Zirconia	

CARBONIC.		PRUSSIC.	
Barita	420*	Barita	400
Strontia	419*	Strontia	
Lime (423)*		Potass	300
Potass?	306*	Soda	298
Soda	304*	Lime	290
Magnesia (366)*		Magnesia	280
Ammonia	339*	Ammonia	270
Glycina	325*	Glycina?	260
Alumina	323*	Alumina?	258
Zirconia	321*	Zirconia?	250

X. *On Crystallography.* By M. HAUY. Translated from the last Paris Edition of his *Traité de Minéralogie**.

ADVERTISEMENT.

Of the *Synonymies* employed in the following Treatise, and other Objects of Detail.

SYNONYMIES are as it were rallying points between the various authors who write upon one and the same natural science. I am fully aware how indispensable it is to attend to them, particularly in a work containing a certain number of new denominations. My greatest difficulty was to procure names, which in the German language correspond with those by which we designate the different mineral species. M. Leopold de Buch, a mineralogist of deserved celebrity, was kind enough, during his stay in Paris, to visit the cabinet of the School of Mines, and to arrange and ticket a collection of specimens, according to the method of the celebrated Werner.

The figures have been traced by the method of projections, supposing the points of view to be removed *ad infinitum*. The full lines represent the ridges situated in the part of the solid, which will be turned towards the observer if he sees it in the position to which the projection refers: the punctured lines represent the ridges situated in the opposite part, or that which an observer could not see, unless the solid was diaphanous.

In the figures relating to geometrical constructions, we have represented the diagonal and other lines as lying upon the faces of the solid, by suites of partial lines which leave small empty spaces between them: vide *mr, cm, cr*, (fig. 4,) Plate IX †, and *bg, ad, bf, fg, fs*, (fig. 9,) *ibid.*; and we have represented the axes and other lines which traverse the solid, as well as those which are external, so far as

* In compliance with the wishes of many of our scientific readers, we intend to present the public with a translation of the first volume of M. Haüy's celebrated work on Mineralogy, being that which contains his Crystallography. The Introduction was given in our last volume.

† Besides the usual *Numbers* on the plates, for reference in our own volumes, we shall preserve, on those which relate to Crystallography, M. Haüy's order of numeration, to prevent confusion.

it is concerned, by a series of partial lines, with intermediate points, vide *cg*, (fig. 9,) Plate IX., and *MR*, *CM*, *CR*, (fig. 4,) *ibid.* We should remark upon this same figure, that the upper parts of the lines *Ms*, *Rz*, which are situated in the space, are assemblages of partial lines interspersed with points, while their lower parts, applied upon the surface of the solid, are composed of partial lines without intermediate points. This distribution, for the happy idea of which we are indebted to M. Tremery, mining engineer, will assist the reader in finding his way in the assortment of lines with which projections are complicated, by enabling him to seize at the first glance the various functions of these lines.

In indicating the measures of angles relative to each variety of crystalline form, I shall not repeat those which, being common to it with other varieties formerly described, are already indicated by the latter. It will be easy to recognise them from the conformity of the letters, which upon the different figures designate the faces similarly situated.

GENERAL IDEA OF MINERALS:

The name of minerals has been given to bodies which, being placed on the surface or in the bowels of the terrestrial globe, are devoid of organization, and only present assemblages of similar molecules united to each other by a power called *affinity*.

Of this number are flints, rubies, diamonds, gold, silver, iron, &c. *Mineralogy* is the name of the science which makes us acquainted with all these different bodies.

The general classification of the bodies which the study of natural history embraces, considered on a grand scale, may be referred to two terms of comparison, which are life and spontaneous motion. From their union the distinctive character of animals is formed: plants live, and yet cannot move spontaneously: minerals are deprived of both faculties. Man, who is alone capable of studying Nature, towers above all the beings around him, in point of intelligence and reason.

The three grand classes of which we are about to treat, with the help of an ulterior and more comprehensive view,

may be reduced to two; one of which includes animals and vegetables under the common name of *organic beings*, and the other comprehends minerals, or *inorganic beings* *.

The manner in which the beings grow or are produced, which are comprised within these two great divisions, presents the most striking difference by which they can be distinguished. In animals and plants their growth takes place by the simultaneous development of all the parts of the individual, in consequence of the nourishment received by the organs destined to elaborate it. Every thing which contributes to the increase of volume is the effect of internal mechanism; or, if new parts be formed externally, as in trees which send out branches and leaves, these parts are only productions of the peculiar substance of the individuals, which, assisted by the action of the nutritive juices, are developed in the same way. In minerals, on the contrary, the increase in volume takes place by an addition of new molecules, which are applied to the surface of the body, in such a way that every thing which existed at each period of growth, remaining fixed, presents on all sides a basis, as it were, for the materials which arrive for continuing the edifice. On

* We find in the bowels of the globe, earthy or metallic stones, the matter of which, by succeeding to organic bodies, such as shells, is modelled in the cavities which the latter had originally occupied. What is called *petrified wood* also presents an apparent conversion of an organic body into a mineral. Lastly, organic bodies which have undergone only slight alterations have been called *fossil shells* and *fossil wood*. Several modern authors, considering all bodies imbedded in the earth as in the regions of mineralogy, have substituted the word *fossil* for *mineral*, and some have applied the latter to metallic ores only. The same authors have denominated the science of fossils *oryetognosy*. We have thought it right to conform to the ancient language, because the expression *mineral*, by the side of *vegetable* and *animal*, makes us perceive more clearly the gradation of the three great collections of beings which have been denominated the *kingdoms of Nature*. We regard the study of fossils, properly so called, as an accessory so far as mineralogy is concerned, inasmuch as the consequences which we may derive from this study relative to the history of the globe rather spring from geology. We know besides, that fossils, at least those which have been primitively in the animal kingdom, have in another point of view occupied the attention of several celebrated zoologists; and among others Cuvier, who has, as it were, recomposed the bodies of animals of which we find no living analogies, and restored to modern science species of antiquity which seemed to have been for ever lost.

one hand, it is constantly the same being which merely passes to other dimensions; on the other hand, it is always a new being in proportion to what it acquires.

We shall have an idea of the formation and increase of minerals, if, after having dissolved common salt in water, we observe what passes while the water is evaporated: we shall see small masses of salt deposited on the surface of the water, or upon the sides of the vessel which contains it, and increase in proportion as they attract new particles. In this case the figure of these masses is out of the question, and we confine ourselves to considering generally the method in which they are formed.

The molecules of stones, metals, &c., may for a time be suspended in a liquid. When this liquid afterwards abandons them successively, from whatever cause, they re-unite, in obedience to their mutual affinity, and produce solid masses*.

These molecules, of which the mineral is the aggregate, are imperceptible to our eyes, even with the assistance of the best optical instruments. But we cannot doubt that they have determinate forms, and that they are not similar in every species of mineral. We are even led to adopt this idea, by observations made upon a great number of minerals.

Let us continue to take as an example the salt already mentioned. If we cautiously strike a portion of this salt, we see it divided into fragments of a cubical form; and on continuing the division, we shall have cubes successively smaller, until they are no longer visible without the microscope.

On the other hand chemistry, by analysing the salt in question, proves that it is composed of two different principles; one of which is an acid called *muriatic acid*, and the other an alkali called *soda*. These two principles are com-

* The action of caloric, or heat, supplies the place of liquids in the formation of certain minerals; when the molecules of the latter, which its interposition at first keeps separated, afterwards acquire, upon its retreat, the liberty of reuniting by virtue of their reciprocal affinity.

bined with each other in the salt, according to a certain proportion and a determinate arrangement. Each cube which we take from this salt is an aggregate, and the connection and arrangement of molecules is the same as in the whole mass. But the subdivision of the salt into cubes successively smaller, has necessarily its limits; and if we were possessed of organs and instruments of sufficient delicacy for pushing this division as far as it would go, we should even obtain cubes incapable of being subdivided without being analysed, *i. e.* without insulating the two principles, the junction of which constitutes the essence of the salt.

Hence we conclude, that we may consider in this salt (and the same may be said of all the minerals) molecules of two orders: the first, which we shall call *elementary molecules*, and which are in the present case, on one hand those of the acid, and on the other those of the soda; the second, to which we shall give the name of *integrant molecules*, and which are in the same case, the smallest cubes which can be obtained separately, without the nature of the salt being destroyed. The elementary molecules have doubtless regular and constant forms also for each species of acid, alkali, &c., and those of one species adapt themselves to those of the other, forming small compartments whence result the integrant molecules.

We shall suppose that these last molecules were similar to the solid ones procured from a mineral by dividing it mechanically. Of this we are not physically certain, since these molecules escape our observation from their extreme tenuity. But in the study of Nature we cannot act more wisely than to adopt this principle: *That things are to be considered precisely as they present themselves to our observation.* The ultimate perceptible results of the mechanical division of minerals, if they do not give us the figure of the true integrant molecules employed by Nature, represent them, at least with respect to us; nearly as the substances which chemists can no longer analyse further, are simple substances with respect to them, although in reality they may still be susceptible of decomposition.

It frequently happens that the cavity in which a mineral is formed contains other minerals of an anterior existence, which afterwards serve it as a support when its formation is completed. Frequently also the molecules of several minerals, suspended at the same time in one and the same liquid, produce cotemporaneous bodies. Hence the mutual adherence of several minerals; those kinds of penetrations, in virtue of which they are often as it were interwoven or dovetailed into each other; those mixtures of molecules of several different bodies; and all those sportive positions, all those varieties of conditions and aspects presented to the observation of the naturalist by a continual change of contrasts and shades.

Every mineralogical collection presents numerous examples of these accidental combinations; and although the chief object of the mineralogist is to classify bodies from considerations independent of their natural arrangement, it is nevertheless not a matter of indifference for him to know what are the other substances which adhere most usually to such and such species of stone or metal, and their indication should have a place in the history of the substance with which circumstances have associated them*. But the observation of masses frequently of stupendous size, in which the respective arrangement of the minerals results from an operation of Nature on a grand scale, is the object of a distinct science called *geology*, which cannot be studied except by travelling.

[To be continued.]

* The French word *gangue* has been applied to stony substances which accompany metallic veins, and *matrix* to substances which support, or contain imbedded in them, other stony substances, or of a nature not metallic. I thought it right to give an extension to the word *gangue*, by applying it indiscriminately to the supports or to the envelopes of a mineral, whatever be its nature. Thus, we say that such a variety of carbonated lime has a quartz for its *gangue*.

XI. *Proceedings of Learned Societies.*

FRENCH NATIONAL INSTITUTE.

Analysis of the Labours of the Class of Mathematical and Physical Sciences of the French Institute, for the Year 1807.

[Continued from vol. xxxiii. p. 501.]

M. BURCKHARDT proposes another new method for determining the moon's node. This inquiry is delicate; for six seconds of error in the meridian altitude may produce a minute of difference in the place of the node. It is true that it is not necessary to be known with any precision except for the calculation of the latitude, and that a minute of error in the node only produces reciprocally six seconds in the moon's latitude. This element has therefore nearly the same precision in the tables as the very observations which serve to determine it. But these observations, when the moon is very low, are subject to the irregularities of refraction; they were in the same way affected with uncertainty, as to the parallax and the semi-diameter, when these two quantities were not yet so well determined as they are now. It is, therefore, the refractions which he endeavours to avoid by making choice of a method over which they have no influence. We do not allude to the errors in the division of the mural circle; for we might, as M. Burckhardt himself has proved, observe the altitudes of the moon by the repeating circle, or determine with the same instrument the errors of the mural circle. The occultations of stars would furnish a method, if their latitudes were certain; but these latitudes may be subject to uncertainties similar to that of the meridian altitude of the moon, when these stars are south; and in order to be proper for the determination of the node, they must be close to the ecliptic. All these considerations singularly limit the choice which we may make; and there is scarcely any other but Regulus and the Virgin's Spike which will satisfy all the requisite conditions. We must confine ourselves to these two stars, and they will be sufficient. We shall choose the eclipses observed successively when the moon was in the vicinity of its ascending and descending node. We may suppose the latitude of the star to be

be good, and we may conclude from it the place of the two nodes. They ought to differ 180 degrees, the known motion excepted of the node, which we must take into account; This difference may serve for correcting the latitude of the star: but even that is unnecessary; for, having the node, (for the two errors act in a contrary direction,) the mean between the two determinations of one and the same node will be the position which this node had at the moment of the two observations, however distant from each other. This method is therefore general and complete; but the opportunities of putting it in practice are unfortunately rare. On consulting the annals of astronomy, M. Burckhardt has only found two observations of the Virgin's Spike, and four of Regulus, which are applicable.

M. Biot, previous to his first journey to Spain, had determined by precise and delicate experiments the refrangent power of the air and of gases, and this he found to be very little different from what M. Delambre concluded from his astronomical observations combined with those of M. Piazzini. We know that the refractions vary with the state and temperature of the atmosphere; and for a long period astronomers applied to the mean quantities two corrections, one depending upon the heat of the barometer, and the other upon the degree marked by the thermometer. Since meteorology was enriched with a third instrument, which serves for measuring the degrees of dryness and humidity in the air, astronomers were uncertain if the hygrometer could furnish a third correction. Some trials had been already made, which had given nothing accurate. For nearly a month which M. Delambre spent in the steeple of *Bois-commun*, at a time when strong frosts had more than once succeeded to very damp fogs, he sought to ascertain if the variations of the hygrometer produced any change in the terrestrial refractions, and he never found the least indication of it. The author of the *Mécanique Céleste* had made the important remark, that, in point of equal elasticity; the refrangent powers of the air and of the vapour of water would only differ by a very small quantity; but the question so essentially interested astronomy, that this truth, already so

probable, was well worthy of being established by direct experiments. This is what M. Biot undertook last summer, with the most delicate accuracy. He had in the first place to determine the effects of vapour by itself: he dried, by means of potash, the warm air contained in his prism; outside of it he had air charged with the natural moisture of the atmosphere. The pressure of these two airs, indicated by the interior and exterior barometers, was not the same; the difference was equal to the tension of the aqueous vapour of the atmosphere. The deviation of the luminous ray in the prism then gave the refraction produced by the vapour; and we might see whether this refraction differed from that which would have been produced by the air alone at a similar temperature. The differences never rose above some tenths of a second, and the medium was only $0''15$, a quantity truly insensible, since it only produces a sixtieth of a second at the height of 45 degrees. M. Biot hence concludes "that the vapour of the air sensibly refracts like the atmospheric air; and thus, in astronomical observations, we should be contented with having in view the height of the barometer and thermometer, and neglect the vapours more or less with which the atmosphere may be charged."

The first experiments of M. Biot were made in winter and in low temperatures: the last took place in the greatest heat of summer, and yet the difference upon the mean refraction only differed by an extremely small quantity, which is still made less by M. Delambre's result. To conclude: all astronomers will easily agree, that the direct observations of the refractions could not give, notwithstanding all possible care, either the same agreement in the particular results, or the same precision in the absolute quantity; because, by the astronomical methods, this value, or the constant part of the refraction, is always dependent upon the altitude of the pole, because we can only determine simultaneously the two unknown quantities; and we may always, by causing small changes in a contrary direction, represent the observations equally well. M. Delambre has declared that he cannot account for the small difference which exists between his refractions and those of M. Biot. We may therefore adopt

in preference the result of these physical experiments; it is only by calculating with the greatest precision, millions of observations made at different times, and with different kinds of instruments, that we can attain this point of approximation. If we afterwards compare the new table of refractions with those of Bradley, Mayer, Burg, and Piazzzi, we shall perhaps be astonished at the little that has been gained by so many various observations, calculations, and experiments: but such is the present state of astronomy, that the greatest efforts can produce little more than almost insensible ameliorations, although we certainly gain in point of accuracy in proportion as experiments become more exact and rigorous. The same comparison will prove that the greatest difference between the various tables chiefly belongs to the constant factor of the thermometrical correction. In fact, as far as 80° of distance from the zenith, at which the observations differ more from each other than they are removed from the tables, scarcely can we find, in the mean refractions, one or two seconds of difference among astronomers, if we except M. Burg, who has frequently a double quantity in excess, instead of our seeing in very high or very low temperatures uncertainties of 9 or 10 seconds. It was therefore extremely necessary to verify this co-efficient; and this is what M. Biot has done with the same success. The quantity which he found, according to his own experiments and those of Gay Lussac, scarcely exceeds what Mayer had determined 50 years ago, and to which Lacaille found almost nothing to add. Bradley made this co-efficient a little larger, and almost every astronomer has adopted his table.

M. Biot, who employs his time so usefully, also read several excellent memoirs to the Institute this year; but his departure for Spain does not admit of our analysing them: he is at present occupied at Formentera, a small island to the southward of Ivica, in measuring the altitude of the pole, the length of the pendulum, and the azimuths of the most southern points of the triangles which he drew from that island to Tortosa, where the death of M. Mechain had caused them to be suspended. Messrs. Chaix and Rodriguez, but above all M. Arago, took the most active part in
this

this great and difficult operation, which will form a very excellent completion to the description of the meridian of Dunkirk and Barcelona. They have fortunately triumphed over every obstacle; by their perseverance in braving the severest cold, snows, winds, heat, and storms, they succeeded in uniting by two great triangles the isles of Ivica and Formentera on the shores of Valencia. What remains to be done in order to add nearly three degrees to the grand meridian is much easier; and its success is undoubted; because from this moment it depends upon the care and the precision of the geometrical and physical knowledge with which our young astronomers are endowed, as well as upon their zeal and courage.

M. Messier has presented to the class a beautiful drawing which he made of the nebulus of Orion, to which he has added that of Legentil, and another much more difficult to see, which he discovered in 1773. Some astronomers thought they had remarked on a large scale changes of form and of light, owing probably to the different glasses which they used. M. Messier gives the dimensions and size of his glasses; and with his drawing, which appears in our *Memoirs* of 1807, astronomers will one day be able to ascertain if these changes are real, or only optical illusions.

The storm which was experienced at Paris on the 21st of October, 1807, and the no less extraordinary wind of the following day, deserve to be recorded in the annals of meteorology. M. Messier has collected all the details with care, and has consulted all the registers of observations kept for 50 years without finding any thing similar. At the conclusion of a no less violent storm, which took place on the 3d of November following, the lightning struck the church of Montvilliers; and M. Messier has also presented us with details respecting this catastrophe.

The year 1807 will be celebrated by the discovery of a new planet, and the long-continued appearance of one of the most beautiful comets ever seen. The planet was discovered at Bremen by M. Olbers, and the letter to M. Lalande, announcing the circumstance, arrived a few minutes after the death of that prince of astronomers. M. Burckardt immediately

mediately gave us the first approximate elements, and he improved them in proportion as his observations became more numerous. We have a remarkable proof of the perfection of the modern methods, in this facility of finding the instant of the appearance of a new heavenly body, all the circumstances attending its course, the form and position of the orbit which it describes around the sun. On this occasion, therefore, analogy considerably abridged the first attempts. The three last planets had already the singularity of their distance from the sun being nearly the same. According to M. Olbers' ideas, which contributed to the discovery by directing him in his inquiries, the planet Vesta ought also to have this resemblance with Ceres, Pallas, and Juno; and this conjecture has been almost completely verified. In order to obtain a more certain knowledge of this point, and of the true elements, we must wait until we have observed a greater arc, and calculated the perturbations which Vesta ought to undergo, particularly with respect to Jupiter. M. Burckhardt has already ascertained that these perturbations are very sensible, although less difficult to calculate than those of Pallas.

A comet was discovered at Marseilles, by M. Pons, on the 21st of October: it was then south, and adjoining the horizon, and his track followed nearly that of the sun. These circumstances hindered more northern astronomers from seeing it immediately; for M. Bouvard, on the same evening, took an accurate view of the whole sky without seeing any thing unusual: as it was from that moment visible to the naked eye, it was perceived a few days afterwards by Messrs. Vidal and Flauguergues, and by different astronomers at Madrid, and in Germany. M. de Thulis, director of the observatory of Marseilles, sent us his first two observations, M. Burckhardt added a third, and next day he gave the first elements of the orbit. He has perfected them since. Messrs. Bouvard and Mathieu have made similar calculations upon other observations. The parabolic elements seem to be well known, and we have nothing to add on the subject of this comet which we have not read in the Journals. Its long continuation, however, gave M. Burckhardt reason to hope that

that it might give rise to some interesting remarks, and it is probable that he will give to the public those made by himself.

The same astronomer has also been occupied with describing several former comets, of which an imperfect description has appeared. In the Imperial observatory he found some unpublished observations of the comet of 1701, seen at Pau by M. Pallu. M. Burekhardt supposes that this comet is the same which was seen at sea in the month of February following; and this circumstance, in his opinion, is worthy of being examined.

The comet of 1672 had been supposed by some astronomers to have been the same with that of 1805. M. Burekhardt has shown by calculations, that this is not the case.

[To be continued.]

ROYAL ACADEMY OF SCIENCES AND BELLES LETTRES OF BERLIN.

This learned body has offered medals of fifty ducats in value each for the best memoirs on the following subjects, viz. "A complete theory of the Hydraulic Ram, taking into view the adhesion of water."

"The determination of the object of the senate of the Amphictyons, the extent of their powers, and their influence over the politics of Greece."—The papers on the above subjects must be given in on or before the 1st of May 1810.

ACADEMY OF SCIENCES OF COPENHAGEN.

The following subjects have been given out as prize questions for the present year.—*In Mathematics.* "Explain the construction and theory of a hydraulic tube, by means of which we may distinctly observe objects at the bottom of the sea."—*In Physics.* "What information has been or may be gained respecting the state of the atmosphere in the higher regions, by means of aerial voyages?"—*In History.* "Compare the best and newest accounts we have of the worship and religious ideas of the various Indian or Tartar nations, and their opinions respecting the origin and the primitive state of theology, and of the world, with the ideas which

which our ancestors entertained upon the same subjects.”—
In Philosophy. “Has the eclectic philosophy any thing which can justly render it recommendable at present? What men have deserved to be honoured with the title of eclectics? and according to these results, May the philosophers who were formerly the ornaments of the School of Alexandria, or the new School of Plato, be called *eclectic*, or, according to the opinion of some, *syncretic*?” A gold medal of the value of 50 ducats is offered for the best memoir on either of the above subjects. The papers may be written in Latin, Danish, English, or French, and must be transmitted to Professor Bugge, secretary to the Copenhagen Academy, before the 1st of January 1810.

XII. *Intelligence and Miscellaneous Articles.*

DR. BREWSTER of Edinburgh has invented a new goniometrical telescope and microscope, for measuring the angles of crystals by reflection, and for ascertaining the inclination of strata, and the apparent magnitude of angles when the eye is not placed at their vertex.

The same gentleman has also invented an instrument for determining distances at one station, without measuring a base, without a portable base being attached to the instrument; or without knowing the magnitude of the object the distance of which is to be ascertained. A long base is actually created by the instrument, without measuring it; and the distance is obtained upon a principle, which, as far as we know, has never been employed in trigonometrical instruments.

The art of printing from stone continues to be practised with great success on the Continent. At Stutgard a printing-office has been established, for the purpose of a more extensive application of this new invention. The engraving of music has been the chief branch to which it has hitherto been directed on the Continent.

M. DEGEN, a watchmaker of Vienna, has invented a
machine

machine for raising a person into the air. It is formed of two kinds of parachutes of taffeta, which may be folded up or extended at pleasure, and the person who moves them is placed in the centre. M. Degen has made several public experiments, and rose to a height of 54 feet, flying in various directions with the celerity of a bird. A subscription has been opened at Vienna to enable the inventor to prosecute his inquiries.

BARON LUTGENDORF, long known as a traveller and voyager, has contrived a machine by which a person may exist under water, without fear of being drowned; it is a kind of cuirass, which admits of the body assuming every possible position, and which is said to be extremely useful in saving persons in danger of being drowned. The police of Vienna have purchased a considerable number of these machines, with the view of assisting in bringing up drowned persons from the bottom of the Danube.

AEROSTATION.—On the 22d of August, 1808, Messrs. Andreoli and Brioschi, of Padua, ascended in a balloon, amid an immense concourse of spectators. Soon after leaving the ground, the barometer having fallen to 15 inches, M. Brioschi began to feel an extraordinary palpitation of the heart; his breathing, however, was not affected: the barometer afterwards fell to 12 inches, and he was overcome with a gentle sleep, which ended in a complete lethargy. The balloon continued ascending; and when the barometer stood at nine inches M. Andreoli perceived that the machine was completely inflated, and that he could not move his left hand. The mercury continuing to descend, marked eight inches and a half, and a violent detonation was heard from the balloon, which then descended with great rapidity, and M. Brioschi awoke. The aëronauts alighted safely on the hill of Euganea, not far from Petrarch's tomb and the city of Argua, about twelve miles from Padua. The voyage lasted from half-past three until half-past eight o'clock.

DR. LANGSDORFF, of St. Petersburg, whose zèal for the progress of science is already well known, has been appointed by

by Count Romanzow to a mission of considerable importance. Dr. Lapsdorff accompanies a large caravan, which has set out from Orenbourg for Russian Tartary and Bucharía, in quality of physician and surgeon. The Russian government has supplied him with every requisite for making his journey advantageous to natural history and geography.

LIST OF PATENTS FOR NEW INVENTIONS.

To James Cavanah Murphy, of Edward Street, Cavendish-Square, architect, who during a residence of eight years on the Continent has discovered and found out the manner of designing, making, and forming mosaics and ornaments in the Arabian style and manner, which he purposes to apply to divers arts and manufactures.—Dated July 26, 1809.

To Samuel Clegg, of Manchester, in the county of Lancaster, engineer, for a rotative (steam) engine, the piston of which makes a complete revolution at a distance from the revolving axis, shaft, or cylinder.—July 26.

To Thomas Botfield, of Hopton Court, in the county of Salop, for a method of constructing an iron or metal roof for houses or other buildings.—July 26.

To Richard Heaps, of Holywell Street, in the parish of St. Leonard, Shoreditch, for his method of forming pipes and sundry other articles in lead, pewter, or tin, or metals of that nature.—July 26.

To David Loeschman, of Newman Street, piano-forte maker, for certain improvements in the musical scale of keyed instruments with fixed tones, such as pianos, organs, &c.—July 26.

To Charles Seward, of Lancaster, for a new or improved street lamp and burner, and lantern-head for street and other lamps and lanterns. July 26.

METEOROLOGICAL TABLE,
By MR. CAREY, OF THE STRAND,
For July 1809.

Days of the Month.	Thermometer.			Height of the Barom. Inches.	Degrees of Dryness by Leslie's Hygrometer.	Weather.
	8 o'Clock, Morning.	Noon.	11 o'Clock, Night.			
June 27	52°	69°	55°	30·15	82	Fair
28	54	63	50	·08	35	Cloudy
29	51	60	54	29·98	41	Cloudy
30	52	67	57	·89	51	Cloudy
July 1	57	70	55	·84	52	Fair
2	52	64	51	·75	0	Rain
3	52	57	49	·50	25	Cloudy
4	52	55	56	·48	5	Thunder with Rain
5	51	60	55	·57	15	Showery
6	50	61	57	·72	5	Rain
7	56	68	60	·84	35	Cloudy
8	57	70	57	·86	55	Fair
9	50	56	50	·85	29	Rain
10	52	58	51	·92	15	Rain
11	53	68	61	30·05	52	Fair
12	59	73	62	·10	52	Fair
13	61	69	55	·15	72	Fair
14	62	71	64	·20	62	Fair
15	64	72	63	·05	63	Fair
16	65	73	60	29·98	60	Fair
17	63	70	50	·75	64	Fair
18	51	63	53	·94	61	Fair
19	55	68	58	30·04	69	Fair
20	59	70	56	·18	64	Fair
21	57	70	57	·19	72	Fair
22	57	65	60	·61	42	Cloudy
23	59	72	60	29·94	47	Fair
24	58	70	60	·85	41	Fair
25	61	77	61	·76	50	Fair
26	62	72	62	·75	39	Cloudy

N. B. The Barometer's height is taken at one o'clock.

XIII. *An Account of a Method of dividing astronomical and other Instruments, by ocular Inspection; in which the usual Tools for graduating are not employed; the whole Operation being so contrived, that no Error can occur but what is chargeable to Vision, when assisted by the best optical Means of viewing and measuring minute Quantities.* By Mr. EDWARD TROUGHTON*.

A Letter from Mr. EDWARD TROUGHTON, Mathematical Instrument Maker, to the Astronomer Royal †.

SIR, London, June 23, 1809.
THE science which you profess, and the art which it has fallen to my lot to cultivate, are so nearly allied; that, had I been personally unknown to you, and a stranger to the patronage which you have always given to the useful arts, I should still have wished the papers annexed to have passed through your hands to the public. You will readily thence infer, how much I feel myself flattered by having obtained, from your condescension, the privilege of their being presented to the Royal Society through a channel which must secure for them the most favourable reception.

My reputation for the dividing of astronomical and other instruments, is by no means unknown to the world; but the means by which I accomplish it, I have hitherto thought proper to conceal: and if that concealment had been essential to the advancing of that reputation, or to the immediate security of my own interests, it is probable that it might still longer have rested with myself. Relying, however, as I do, on the probability that I shall find sufficient employment while I am capable of active life, I know of no honourable motive that should prevent me from allowing it to be useful to others.

How a young artist, who may just be beginning to make his way to fame or wealth, may receive it, I know not; but I wish him to understand, that I consider myself now in the act of making him a very valuable present.

I have the honour to be, sir,

your obliged and obedient servant,

EDW. TROUGHTON.

To the Rev. NEVIL MASKELYNE, D.D.,
 Astronomer Royal, F.R.S., &c.

* From Philosophical Transactions for 1809, Part I.

† This letter is not inserted in the Society's Transactions, but appears in the copies of the Paper circulated by the author among his private friends.—

EDIT.

Vol. 34. No. 136. August 1809.

F

Account

Account of a Method of dividing astronomical and other Instruments, by ocular Inspection, &c.

It would ill become me, in addressing myself to the Members of this Society upon a subject which they are so well enabled to appreciate, to arrogate to myself more than may be assigned as my due, for whatever of success may have been the result of my long continued endeavours, exerted in prosecuting towards perfection *the dividing of instruments immediately subservient to the purposes of astronomy*. A man very naturally will set a value upon a thing on which so much of his life has been expended; and I shall readily, therefore, be pardoned for saying, that considering some attainments which I have made on this subject as too valuable to be lost, and being encouraged also by the degree of attention which the Royal Society has ever paid to practical subjects, I feel myself ambitious of presenting them to the public through what I deem the most respectable channel in the world.

It was as early as the year 1775, being then apprentice to my brother, the late Mr. John Troughton, that the art of dividing had become interesting to me; the study of astronomy was also new and fascinating; and I then formed the resolution to aim at the nicer parts of my profession.

At the time alluded to, my brother, in the art of dividing, was justly considered the rival of Ramsden; but he was then almost unknown beyond the narrow circle of the mathematical and optical instrument makers; for whom he was chiefly occupied in the division, by hand, of small astronomical quadrants, and Hadley's sextants of large radius. Notwithstanding my own employment at that time was of a much inferior nature, yet I closely inspected his work, and tried at leisure hours on waste materials to imitate it. With as steady a hand, and as good an eye, as young men generally have, I was much disappointed at finding, that after having made two points, neat and small to my liking, I could not bisect the distance between them, without enlarging, displacing, or deforming them with the points of the compasses. This circumstance gave me an early dislike to the tools then in use; and occasioned me the more uneasiness, as I foresaw that it was an evil which no practice, care, nor habit could entirely cure. Beam-compasses, spring-dividers, and a scale of equal parts, in short, appeared to me little better than so many sources of mischief.

I had already acquired a good share of dexterity, as a general workman. Of the different branches of our art, that of *turning* alone seemed to me to border on perfection. This
juvenile

juvenile conceit, fallacious as I afterwards found it, furnished the first train of thoughts, which led to the method about to be described; for it occurred to me, that if I could by any means apply the principle of turning to the art of dividing instruments, the tools liable to objection might be dispensed with. The means of doing this was first suggested, by seeing the action of the perambulator, or measuring wheel; the surface of the earth presenting itself as the edge of the instrument to be divided, and the wheel of the perambulator as a narrow roller acting on that edge; and hence arose an idea that some easy contrivance might be devised, for marking off the revolutions and parts of the roller upon the instrument. Since the year above mentioned, several persons have proposed to me, as new, dividing by the roller, and I have been told, that it also occurred long ago to Hook, Sisson, and others; but, as Hatton on watch-making says, "I do not consider the man an inventor, who merely thinks of a thing; to be an inventor, in my opinion, he must act successfully upon the thought, so as to make it useful." I had no occasion, however, to have made an apology for acting upon a thought, which, unknown to me, had been previously conceived by others; for it will be seen in the sequel, how little the roller has to do in the result, and with what extreme caution it is found necessary to employ it.

When a roller is properly proportioned to the radius of the circle to be divided, and with its edge made a small matter conical, so that one side may be too great, and the other side too little, it may be adjusted so exactly, that it may be carried several times around the circle, without the error of a single second; and it acts with so much steadiness, that it may not unaptly be considered as a wheel and pinion of indefinitely high numbers. Yet, such is the imperfection of the edges of the circle and roller, that, when worked with the greatest care, the intermediate parts, on a radius of two feet, will sometimes be unequal to the value of half a minute or more. After having found the terminating point of a quadrant or circle so permanent, although I was not prepared to expect perfect equality throughout, yet I was much mortified to find the errors so great, at least ten times as much as I expected; which fact indicated, beyond a doubt, that if the roller is to be trusted at all, it must only be trusted through a very short arc. Had there been any thing slippery in the action, which would have been indicated by measuring the same part at different times differently, there would have

been an end of it at once; but, that not being the case in any sensible degree, the roller becomes an useful auxiliary to fill up short intervals, whose limits have been corrected by more certain means*.

Bird, who enjoyed the undisputed reputation of being the most accurate divider of the age in which he lived, was the first who contrived the means how to render the usual divisions of the quadrant bisecting; which property, except his being unusually careful in avoiding the effects of unequal expansion from change of temperature, chiefly distinguished his method from others who divided by hand. This desirable object he accomplished by the use which he made of a

* There are two things in the foregoing account of the action of the roller which have a tendency to excite surprise. The first is, that the roller should, in different parts of its journey round the circle, measure the latter so differently. One would not wonder, however, if in taking the measure across a ploughed field, it should be found different to a parallel measure taken upon a gravel walk; and, in my opinion, the cases are not very dissimilar. Porosity of the metal, in one part of the circle more than in the other, must evidently have the same effect; brass unhammered is always porous; and the part, which has felt the effect of two blows, cannot be so dense as other parts which have felt the effect of three; and, should the edge of the circle be indented by *jarring-turning*, it would produce a visible similitude to ploughed ground. Every workman must be sufficiently upon his guard against such a palpable source of error; yet, perhaps with our greatest care we may not be able to avoid it altogether. The second is, that notwithstanding the inequality above mentioned, the roller having reached the point upon the circle from whence it set out, should perform a second, third, &c., course of revolutions, without any sensible deviation from its former track; this is not perhaps so easily accounted for. It must be mentioned, that the exterior border of the circle should be *turned rounding*, presenting to the roller a convex edge, whose radius of curvature is not greater than one-tenth of an inch. Now, were the materials perfectly inelastic and impenetrable, the roller could only touch the circle in a *point*, and in passing round the circle, it could only occupy a *line* of contact. This in practice is not the case; the circle always marks the roller with a broad list, and thereby shows that there is a yielding between them to a considerable amount. The breadth of this list is not less than one-fiftieth of an inch; and it follows, that at least 12° of the circle's edge must be in contact at the same time; that the two surfaces yield to each other in depth, by a quantity equal to the *ver. sin.* of half that arc, or $\frac{1}{1800}$ th of an inch; and that the circle has always hold of the roller by nearly 1° of the edge of the latter. Whoever has examined the surfaces of metals which have rolled against each other, must have observed that peculiar kind of indentation that always accompanies their action; and there can be no doubt that the particles of a roller, and those of the surface on which it acts, which mutually indent each other, will, upon a second course begun from the same point, indent each other deeper: this is not, however, exactly the case in question; for, whatever of fitting might have taken place between the surfaces of our roller and circle in the first revolution of the former, one should imagine would be obliterated by the fifteen turns which it must repeat over fresh ground. Experience shows, however, as every one will find who tries the experiment with good work, that on coming round to the point of commencement, the roller has the disposition to regain its former track; for, were this not the case, although the commensurate diameters were adjusted so exactly as to be without sensible error in one course, yet a less error than that which is so would become visible, when repeated through many courses.

finely

finely divided scale of equal parts. The thing aimed at was, to obtain a point upon the arc at the highest *bisectional number of divisions* from 0, which in his eight feet quadrants was 1024, = $85^{\circ} 20'$. The extent of the beam compasses, with which he traced the arc upon the limb of the instrument to be divided, being set off upon that arc, gave the points 0° and 60° ; which, being bisected, gave 30° more to complete the total arc. A second order of bisections gave points at 15° distance from each other; but that which denoted 75° was most useful. Now, from the known length of the radius, as measured upon the scale, the length of the chord of $10^{\circ} 20'$ was computed, taken off from the scale, and protracted from 75° forwards; and the chord of $4^{\circ} 40'$, being ascertained in the same manner, was set off from 90° backwards, meeting the chord of $10^{\circ} 20'$ in the continually bisectional arc of $85^{\circ} 20'$. This point being found, the work was carried on by bisections, and the chords, as they became small enough, were set off beyond this point to supply the remainder of the quadrantal arc. My brother, whom I mentioned before, from mere want of a scale of equal parts upon which he could rely, contrived the means of dividing bisectionally without one. His method I will briefly state as follows, in the manner which it would apply to dividing a mural quadrant. The arcs of 60° and 30° give the total arc as before; and let the last arc of 30° be bisected, also the last arc of 15° , and again the last arc of $7^{\circ} 30'$. The two marks next 90° will now be $82^{\circ} 30'$ and $86^{\circ} 15'$, consequently the point sought lies between them. Bisections will serve us no longer; but if we divide this space equally into three parts, the most forward of the two intermediate marks will give us 85° , and if we divide the portion of the arc between this mark and $86^{\circ} 15'$ also into three, the most backward of the two marks will denote $85^{\circ} 30'$. Lastly, if we divide any one of these last spaces into five, and set off one of these fifth parts backwards from $85^{\circ} 30'$, we shall have the desired point at 1024 divisions upon the arc from 0° . All the rest of the divisions which have been made in this operation, which I have called marks because they should be made as faint as possible, must be erased; for my brother would not suffer a mark to remain upon the arc to interfere with his future bisections.

Mr. Smeaton, in a paper to be more particularly noticed presently, justly remarks the want of a unity of principle in Mr. Bird's method; for he proceeds partly on the ground of the protracted radius, and partly upon that of the computed chord; which, as Smeaton observes, may or may not agree.

Bird, without doubt, used the radius and its parts in order to secure an exact quadrant; but Smeaton, treating exactness in the total arc as of little value to astronomy, would, in order to secure the more essential property of equality of division, reject the radius altogether, and proceed entirely upon the simple principle of the computed chord. The means pursued by my brother, to reach the point which terminates the great bisecting arc, is the only part in which it differs from Bird's method; and I think it is without prejudice that I give it the preference. It is obvious that it is as well calculated to procure equality of division, as the means suggested by Smeaton; at the same time that it is equal to Bird's in securing the precise measure of the total arc. It proceeds entirely upon the principle of the protracted chord of 60° and its subdivision; and the uncertainty, which is introduced into the work by the sparing use which is made of subdivision by 3 and 5, is, in my opinion, likely to be much exceeded by the errors of a divided scale*, and those of the hand and eye, in taking off the computed chords, and applying them to the arc of the instrument to be divided.

Ramsden's well known method of dividing by the engine unites so much accuracy and facility, that a better can hardly be wished for; and I may venture to say that it will never be superseded, in the division of instruments of *moderate radii*. It was well suited to the time in which it appeared; a time when the improvements made in nautical astronomy, and the growing commerce of our country, called for a number of reflecting instruments, which never could have been supplied, had it been necessary to have divided them by hand: however, as it only applies to small instruments, it hardly comes within the subject of this paper.

The method of Hindley, as described by Smeaton †, I will venture to predict will never be put in practice for dividing astronomical instruments, however applicable it might formerly have been for obtaining numbers for cutting clock-work, for which purpose it was originally intended. It consists of a train of violent operations with blunt tools, any one of which is sufficient to stretch the materials beyond, or press them within their natural state of rest; and, although the whole is done by contact, the nature of this contact is such as, I think, ought rather to have been contrasted with, than represented as being similar to, the nature of the con-

* That Bird's scale was not without considerable errors, will be shown towards the end of this paper.

† Philosophical Transactions for 1788.

tact used in Smeaton's pyrometer, which latter is performed by the most delicate touch; and is represented, I believe justly, to be sensible to the $\frac{1}{80000}$ th part of an inch. Smeaton has, however, acquitted himself well, in describing and improving the method of his friend; and the world is particularly obliged to him for the historical part of his paper, as it contains valuable information which perhaps no one else could have written.

The only method of dividing large instruments now practised in London, that I know of, besides my own, has not yet, I believe, been made public. It consists in dividing by hand with beam compasses and spring dividers, in the usual way; with the addition of examining the work by microscopes, and correcting it, as it proceeds, by pressing forwards or backwards by hand, with a fine conical point, those dots which appear erroneous; and thus adjusting them to their proper places. The method admits of considerable accuracy, provided the operator has a steady hand and good eye; but his work will ever be irregular and inelegant. He must have a circular line passing through the middle of his dots, to enable him to make and keep them at an equal distance from the centre. The bisecting arcs, also, which cut them across, deform them much; and, what is worse, the dots which require correction (about two thirds perhaps of the whole) will become larger than the rest, and unequally so in proportion to the number of attempts which have been found necessary to adjust them. In the course of which operation, some of them grow insufferably too large, and it becomes necessary to reduce them to an equality with their neighbours. This is done with the burnisher, and causes a hollow in the surface, which has a very disagreeable appearance. Moreover, dots which have been burnished up are always ill-defined, and of a bad figure. Sir George Shuckburgh Evelyn, in his paper on the Equatorial*, denominates these "doubtful or bad points;" and (considering the few places which he examines) they bear no inconsiderable proportion to the whole. In my opinion, it would be a great improvement of this method, to divide the whole by hand at once, and afterwards to correct the whole; for a dot forced to its place, as above, will seldom allow the compass-point to rest in the centre of its apparent area: therefore other dots made from those will scarcely ever be found in their true places. This improvement also prevents the corrected dots from being injured, or moved, by the future

* Philosophical Transactions for 1793.

application of the compasses, no such application being necessary.

I will now dismiss this method of dividing, with observing, that it is tedious in the extreme; and did I not know the contrary beyond a doubt, I should have supposed it to have surpassed the utmost limit of human patience*. When I made my first essay at subdividing with the roller, I used this method, according to the improvement suggested above, of correcting a few primitive points; but even this was too slow for one who had too much to do. Perhaps, however, had my instruments been divided for me by an assistant, I might not have grudged to have paid him for the labour of going through the whole work by the method of adjustment; nor have felt the necessity of contriving a better way.

I might now extend the account of my method of dividing to a great length; by relating the alterations which the apparatus has undergone during a long course of years †, and the various manner of its application, before I brought it to its present state of improvement; but I think I may save myself that trouble, for truly I do not see its use: I will, therefore, proceed immediately to a disclosure of the method, as practised on a late occasion, in the dividing of a four feet meridian circle, now the property of Stephen Groombridge, esq., of Blackheath.

The surface of the circle which is to receive the divisions, as well as its inner and outer edges, but especially the latter, should be turned in the most exact and careful manner; the reason for which will be better understood, when we come to describe the mode of applying the roller: and, as no projection can be admitted beyond the limb, if the telescope, as is generally the case, be longer than the diameter, those parts which extend further must be so applied, that they may be removed during the operation of dividing. Fig. 1

* At the time alluded to, the double microscopic micrometer was unknown to me, and I did not learn its use, for these purposes, till the year 1790, from general Roy's description of the large theodolite. Previous to that time, I had used a frame which carried a single wire very near the surface to be divided; this wire was moveable by a fine micrometer screw, and was viewed by a single lens inserted in the lower end of a tube, which, for the purpose of taking off the parallax, was four inches long. The greatest objection to this mode of constructing the apparatus is, that the wire being necessarily exposed, is apt to gather up the dust; yet it is preferable to the one now in use, in cases where any doubt is entertained of the accuracy of the plane which is to receive the divisions.

† The full conception of the method had occupied my mind in the year 1778; but as my brother could not be readily persuaded to relinquish a branch of the business to me in which he himself excelled, it was not until September 1785 that I produced my first specimen, by dividing an astronomical quadrant of two feet radius.

and 2 represent the principal parts of the apparatus; fig. 1 showing the plan, and fig. 2 the elevation; in both of which the same letters of reference are affixed to corresponding parts, and both are drawn to a scale of half dimensions. AA is a part of the circle, the surface of which is seen in the plan, and the edge is seen in the elevation. BBB is the main plate of the apparatus, resting with its four feet *aaaa* upon the surface of the arc; these feet, being screws, may be adjusted so as to take equal shares of the weight, and then are fastened by nuts below the plate, as shown in fig. 2. CC and DD are two similar plates, each attached to the main plate, one above and the other below, by four pillars; and in them are centred the ends of the axis of the roller E. F and G are two friction wheels, the latter firmly fastened to B, but the former is fixed in an adjustable frame, by means of which adjustment these wheels and the roller E may be made to press, the former on the interior, and the latter on the exterior edge of the circle, with an equal and convenient force*. At the extremities of the axis of the roller, and attached to the middle of the plates C and D, are two bridges, having a screw in each; by means of which an adjustment is procured for raising or lowering the roller respecting the edge of the circle, whereby the former, having its diameter at the upper edge about $\cdot 001$ of an inch greater than at the lower edge (being, as before described, a little conical), it may easily be brought to the position where it will measure the proper portion of the circle.

Much experience and thought upon the subject have taught me, that the roller should be equal to one sixteenth part of the circle to be divided, or that it should revolve once in $22^{\circ} 30'$; and that the roller itself should be divided into sixteen parts; no matter whether with absolute truth, for accuracy is not at all essential here. Each of such divisions of the roller will correspond with an angle upon the circle of $1^{\circ} 24' 22'' \cdot 5$, or $\frac{1}{16}$ th part of the circle. This number of principal divisions was chosen, on account of its being capable of continual bisection; but they do not fall in with the ultimate divisions of the circle, which are intended to be equal to $5'$ each.

The next thing to be considered is, how to make the roller measure the circle. As two microscopes are here necessary, and those which I use are very simple, I will in this place

* Sufficient spring for keeping the roller in close and uniform contact with the edge of the circle, is found in the apparatus, without any particular contrivance for that purpose; the bending of the pillars of the secondary frames and of the axis of the roller, chiefly supplies this property.

give a description of them. Fig. 6 is a section of the full size; and sufficiently explains their construction, and the position of the glasses; but the micrometer part and manner of mounting it, are better shown at H, in fig. 1 and 2. The micrometer part consists of an oblong square frame, which is soldered into a slit, cut at right angles in the main tube; another similar piece nicely fitted into the former, and having a small motion at right angles to the axis of the microscope, has at one end a cylindrical guide pin, and at the other a micrometer screw; a spring of steel wire is also applied, as seen in the section, to prevent play, by keeping the head of the micrometer in close contact with the fixed frame. This head is divided into one hundred parts, which are numbered each way to 50; the use of which will be shown hereafter. A fine wire is stretched across the moveable frame, for the purpose of bisecting fine dots. Two of these microscopes are necessary; also a third, which need not have the divided head, and must have in the moveable frame two wires crossing each other at an angle of about 30° : this microscope is shown at I, fig. 1. In the two first micrometers, a division of the head is of the value of about 0.2 , and the power and distinctness such, that when great care is taken, a much greater error than to the amount of one of these divisions cannot well be committed in setting the wire across the image of a well made dot. The double eye-glass has a motion by hand, for producing distinct vision of the wire; and distinct vision of the dots is procured by a similar adjustment of the whole microscope.

The first step towards sizing the roller, is to compute its diameter according to the measure of the circle, and to reduce it agreeably thereto, taking care to leave it a small matter too large. The second step is, after having brought the roller into its place in the plate BB, to make a mark upon the surface of the circle near the edge, and a similar one upon the roller, exactly opposite each other; then carry the apparatus forward with a steady hand, until the roller has made sixteen revolutions. If, now, the mark upon the roller, by having over-reached the one upon the circle, shows it to be much too large, take it out of the frame and reduce it by turning accordingly: when, by repeating this, it is found to be very near, it may be turned about $.001$ of an inch smaller on the lower edge, and so far its preparation is completed. The third and last step is, the use and adaptation of the two microscopes; one of these must take its position at H in fig. 1, viewing a small well-defined dot made for the purpose on the circle; the other, not represented in

the figure, must also be fixed to the main plate of fig. 1, as near to the former as possible, but viewing one of the divisions on the roller. With a due attention to each microscope, it will now be seen to the greatest exactness when, by raising or depressing the roller, its commensurate diameter is found.

Fig. 3 is a representation of the apparatus for transferring the divisions of the roller to the circle. It consists of two slender bars, which, being seen edgewise in the figure, have only the appearance of narrow lines; but, when looked at from above, they resemble the form of the letter A. They are fastened to the main frame, as at W and Z, by short pillars, having also the off leg of the angle secured in the same manner, Y is a fine conical steel point for making the dots, and X is a feeler, whereby the point Y may be pressed down with a uniform force, which force may be adjusted, by bending the end of the bar just above the point, so as to make the dots of the proper size. The point Y yields most readily to a perpendicular action; but is amply secured against any eccentric or lateral deviation.

The apparatus, so far described, is complete for laying our foundation, *i. e.* making 256 primary dots; no matter whether with perfect truth, or not, as was said respecting the divisions of the roller; precision in either is not to be expected, nor wished; but it is of some importance, that they should be all of the same size, concentric, small, and round. They should occupy a position very near the extreme border of the circle, as well to give them the greatest radius possible, as that there should be room for the stationary microscope and other mechanism, which will be described hereafter.

It must be noticed, that there is a clamp and adjusting screw attached to the main plate of fig. 1; but, as it differs in no respect from the usual contrivances for quick and slow motion, it has been judged unnecessary to incumber the drawing with it.

Now, the roller having been adjusted, with one microscope H upon its proper dot on the circle, and the other microscope at the first division on the roller; place the apparatus of fig. 3 so that the dotting point Y may stand directly over the place which is designed for the beginning of the divisions. In this position of things, let the feeler X be pressed down, until its lower end comes in contact with the circle; this will carry down the point, and make the first impression, or primary dot, upon the circle; unclamp the apparatus, and carry it forwards by hand, until another division
of

of the roller comes near the wire of the microscope; then clamp it, and with the screw motion make the coincidence complete; where again press upon the feeler for the second dot: proceed in this manner until the whole round is completed.

From these 256 erroneous divisions, by a certain course of examination, and by computation, to ascertain their absolute and individual errors, and to form these errors into convenient tables, is the next part of the process, and makes a very important branch of my method of dividing.

The apparatus must now be taken off, and the circle mounted in the same manner that it will be in the observatory. The two microscopes, which have divided heads, must also be firmly fixed to the support of the instrument, on opposite sides, and their wires brought to bisect the first dot, and the one which should be 180° distant. Now, the microscopes remaining fixed, turn the circle half round, or until the first microscope coincides with the opposite dot; and, if the other microscope be exactly at the other dot, it is obvious that these dots are 180° apart, or in the true diameter of the circle; and if they disagree, it is obvious that half the quantity by which they disagree, as measured by the divisions of the micrometer head, is the error of the opposite division; for the quantity measured is that by which the greater portion of the circle exceeds the less. It is convenient to note these errors + or -, as the dots are found too forward or too backward, according to the numbering of the degrees; and for the purpose of distinguishing the + and - errors, the heads, as mentioned before, are numbered backwards and forwards to fifty. One of the microscopes remaining as before, remove the other to a position at right angles; and, considering for the present both the former dots to be true, examine the others by them; *i. e.* as before, try by the micrometer how many divisions of the head the greater half of the semi-circle exceeds the less, and note half the quantity + or -, as before, and do the same for the other semi-circle. One of the micrometers must now be set at an angle of 45° with the other, and the half differences of the two parts of each of the four quadrants registered with their respective signs. When the circle is a vertical one, as in the present instance, it is much the best to proceed so far in the examination with it in that position, for fear of any general bending or spring of the figure; but, for the examination of smaller arcs than 45° , it will be perfectly safe, and more convenient, to have it horizontal; because the dividing apparatus will then carry the micrometers, several perforations being made in the plate B for the limb to
be

be seen through at proper intervals. The micrometers must now be placed at a distance of $22^{\circ} 30'$, and the half differences of the parts of all the arcs of 45° measured and noted as before; thus descending by bisections to $11^{\circ} 15'$, $5^{\circ} 37' 30''$, and $2^{\circ} 48' 45''$. Half this last quantity is too small to allow the micrometers to be brought near enough; but it will have the desired effect, if they are placed at that quantity and its half, *i. e.* $4^{\circ} 13' 7''.5$; in which case the examination, instead of being made at the next, will take place at the next division but one, to that which is the subject of trial. During the whole of the time that the examination is made, all the dots, except the one under examination, are for the present supposed to be in their true places; and the only thing in this most important part of the business, from first to last, is to ascertain with the utmost care, in divisions of the micrometer head, how much one of the parts of the interval under examination exceeds the other, and carefully to tabulate the half of their difference.

I will suppose that every one, who attempts to divide a large astronomical instrument, will have it engraved first. Dividing is a most delicate operation, and every coarser one should precede it. Besides, its being numbered is particularly useful to distinguish one dot from another: thus, in the two annexed tables of errors, the side columns give significant names to every dot, in terms of its value to the nearest tenth of a degree, and the mistaking of one for another is rendered nearly impossible.

The foregoing examination furnishes materials for the construction of the table of half differences, or apparent errors*. The first line of this table consists of two varieties; *i. e.* the micrometers were at 180° distance for obtaining the numbers which fill the columns of the first and third quadrant; and at 90° , for those of the second and fourth quadrant. The third variety makes one line, and was obtained with a distance of 45° : the fourth consists of two lines, with a distance of $22^{\circ} 30'$: the fifth of four lines, with a distance of $11^{\circ} 15''$: the sixth of eight lines, with a distance of $5^{\circ} 37' 30''$: the seventh of sixteen lines, with a distance of $2^{\circ} 48' 45''$: and the eighth and last variety, being the remainder of the table, consists of thirty-two lines, and was obtained with a distance of $4^{\circ} 13' 7''.5$.

The table of apparent errors, or half differences, just ex-

* If the table of real errors be computed as the work of examination proceeds, there will be no occasion for this table at all; but, I think it best not to let one part interfere with another, and therefore I examine the whole before I begin to compute.

plained, furnishes data for computing the table of real errors. The rule is this: Let a be the real error of the preceding dot, and b that of the following one, and c the apparent error, taken from the table of half differences, of the dot under investigation; then is $\frac{a+b}{2} + c =$ its real error. But, as this simple expression may not be so generally understood by workmen as I wish, it may be necessary to say the same thing less concisely. If the real errors of the preceding and following dots are both +, or both -, take half their sum and prefix thereto the common sign; but, if one of them is +, and the other -, take half their difference, prefixing the sign of the greater quantity: again, if the apparent error of the dot under investigation has the same sign of the quantity found above, give to their sum the common sign, for the real error; but if their signs are contrary, give to their difference the sign of the greater for the real error. I add a few examples.

Example I.

For the first point of the second quadrant.

Real error of the first point of the first quadrant	-	0.0
Real error of the first point of the third quadrant	-	6.9
Half sum or half difference	-	3.4
Apparent error of the dot under trial	-	+ 12.2
Real error	-	+ 8.8

Example II.

For the point 45° of the second quadrant.

Real error of the first point of the quadrant	-	+ 8.8
Real error of the last point of the quadrant	-	- 6.9
Half difference	-	+ 0.9
Apparent error of the dot under trial	-	- 8.9
Real error	-	- 8.0

Example III.

Point 88° 6, or last point, of the third quadrant.

Real error of the point 84° 4 of the third quadrant	-	- 21.0
Real error of the point 2° 8 of the fourth quadrant	-	- 2.9
Half sum	-	- 11.9
Apparent error of the dot under trial	-	- 4.0
Real error	-	- 15.9

Example IV.

Point 88° 6, or last, of the fourth quadrant.

Real error of the point 84° 4 of the fourth quadrant	-	- 21.6
Real error of the point 2° 8 of the first quadrant	-	- 10.2
Half sum	-	- 15.9
Apparent error of the dot under trial	-	+ 9.5
Real error	-	- 6.4

It is convenient, in the formation of the table of real errors, that they should be inserted in the order of the numbering of the degrees on their respective quadrants; although their computation necessarily took place in the order in which the examination was carried on, or according to the arrangement in the table of apparent errors. The first dot of the first quadrant having been assumed to be in its true place, the first of the third quadrant will err by just half the difference found by the examination; therefore these errors are alike in both tables. The real error of the first dot of the second quadrant comes out in the first example; that of the fourth was found in like manner, and completes the first line. It is convenient to put the error of the division 90° of each quadrant at the bottom of each column, although it is the same as the point 0° on the following quadrant. The line of 45° is next filled up; the second example shows this; but there is no occasion to dwell longer upon this explanation; for every one, who is at all fit for such pursuits, will think what has already been said fully sufficient for his purpose. However, I will just mention that there can be no danger, in the formation of this table, of taking from a wrong line the real errors which are to be the criterion for finding that of the one under trial; because they are in the line next to it; the others, which intervene in the full table, not being yet inserted. The last course of all is, however, an exception; for, as the examining microscopes could not be brought near enough to bisect the angle $2^\circ 48' 45''$, recourse was had to that quantity and its half; on which account the examination is prosecuted by using errors at two lines distance, as is shown in the two last examples.

When the table of real errors is constructed, the other table, although it is of no further use, should not be thrown away; for, if any material mistake has been committed, it will be discovered as the operation of dividing is carried on; and, in that case, the table of apparent errors must be had recourse to; indeed, not a figure should be destroyed until the work is done.

[To be continued.]

XIV. *On Crystallography.* By M. HAUVY. Translated from the last Paris Edition of his *Traité de Minéralogie.*

[Continued from p. 69.]

OF CRYSTALLIZATION.

WE have been led by observation and reasoning to ascertain that minerals were composed of similar integrant molecules. The way in which they are mechanically divided has besides proved to us, that the cause which solicited these molecules to be mutually attracted, reunited them in rows upon planes situated in the direction of their different faces. These considerations were useful for preparing the development of another very remarkable result of the laws of affinity, which is referred to the external configuration of minerals, and has given birth to one of the most fertile branches of the science of which they are the objects.

Such therefore is the action of these laws upon integrant molecules, that, when nothing disturbs it, the assemblages of these molecules are terminated by plane surfaces, whence result regular forms similar to those of geometrical solids. We have frequent examples of this regularity in the garnet, topaz, emerald, carbonated lime, sulphated barytes, &c.; and in a great number of metallic substances. The sight of these polyhedrons always excites the surprise of a person to whom they are for the first time presented, and they must frequently be shown to him inerusted with their native earth before he can believe in the geometry of nature.

All these regular bodies have been received under the common denomination of *crystals**. The term *crystallization*, which would at first sight appear to apply only to the species of operation from which crystals are produced, has generally a more extensive signification. It expresses in general every assemblage of molecules in solid masses by the help of affinity. If these masses have a symmetrical aspect, they will be the products of regular crystallization properly so called. If their form is vague, and cannot be determined in a precise manner, they will belong to confused crystallization.

The attractive forces which solicit the molecules of a mineral, suspended in a liquid, have a certain reference with the figure of these molecules, and it is in this relation that the tendency consists which the molecules have of themselves to unite conformably to the laws of a regular aggregation. . . But in order that they may attain this object, they

* The origin of this word will be found under the article of *Quartz.*

must have leisure to seek each other, to apply to each other by proper surfaces, and to concur all at the same time to the harmony which ought to result from their aggregation. The liquid must be in a state of repose; its own molecules must slowly abandon those of the mineral, in order to place them in the position most favourable to affinity, and the cavity must be spacious enough, and the liquid sufficiently abundant, for the crystalline molecules to swim in it at full liberty.

If these conditions are not fulfilled; if it happens, for instance, that the liquid is rapidly evaporated, or that any agitation is produced in it, these accidents, which we may regard as disturbing causes of crystallization, will in some measure disarrange the molecules, and force them to be tumultuously precipitated upon each other; and, as a necessary consequence, the traces of the geometrical form which would have taken place in the event of a slow and tranquil aggregation will be more or less altered*.

But as we are only to speak here of crystallization properly so called, an important consideration in the first place presents itself,—a consideration which places minerals by the side of organic beings. In the vegetable kingdom, for instance, all the individuals of the same species seem to have been made after one common model, *i. e.* their flower is composed of parts equal in number and similar in figure; their leaves have the same arrangement, the same contours, &c.—the diversities consist of but light and fugitive shades. In short, when we have seen a single plant, we have seen the whole species.

It is totally different with respect to minerals. Frequently crystals originating from one and the same substance assume very different forms, all equally distinct, and executed with

* The crystals formed in one and the same liquid around different centres of action more or less closely connected with each other, compose groups in which they are situated sometimes parallel to each other, and sometimes crossing each other in different directions, in such a way that they frequently enough appear to penetrate each other mutually. It also happens very generally that they are only salient at one of their parts, above the substance which serves as a support to them. It is a fortunate circumstance when a crystal belongs to the group only by a point, so that its position isolates it in some measure, and permits its form to be entirely developed to the eyes of an observer. But most of the crystals which offer this advantage have been extracted from certain earthy masses in which they were really solitary, and in the midst of which they are formed at the time when these earths were diluted in an aqueous fluid. We may conceive this formation from an experiment of Pelletier, who, having placed argil soaked in a solution of alum, cut this argil into pieces when it was dry, and found internally crystals of alum of the size of a pea. Hence he concluded that the crystalline molecules might have had the power of displacing the argillaceous molecules, and of removing those obstacles which opposed their union.—*Mém. et Observ. de Chimie*, t. i. p. 81.

similar precision. Carbonated lime, for instance, assumes, according to circumstances, the form of a rhomboid; of a regular hexahedral prism; of a solid terminated by twelve scalene angles; or of a dodecahedron with pentagonal faces, &c. Sulphuretted iron, or ferruginous pyrites, produces sometimes cubes and sometimes regular octahedrons; here dodecahedrons with pentagonal faces, there icosahedrons with triangular faces, &c.

It is true that, among the varieties of one and the same species, it often happens that a more compound form differs from a more simple form only by certain facets, similar to those which would result from sections made on the solid angles, or on the ridges of the latter*. Pyrites, for instance, sometimes assumes the form of a cube, the eight solid angles of which being beaten down would expose to view so many triangular facets, in such a manner that this form may be considered as the passage from the cube to the octahedron, with which it is connected by its eight equilateral triangles, which are situated like the faces of this second solid.

But in addition to these transitions being already very singular in themselves, as appertaining to modifications much more sensible than seems to be necessary to distinguish simple varieties, we find on the other hand certain crystalline forms, which, by a singularity still more remarkable, do not exhibit any vestiges of common parts, and present the appearance of a complete metamorphose of the mineral from which they derive their origin. And in order to cite a new example, let us place by the side of each other the regular hexahedral prism of carbonated lime, (Pl. I., fig. 1.) and the scalene dodecahedron with scalene triangular faces (fig. 6.). We can scarcely conceive how two polyhedrons, so dissimilar at first view, come to touch together, and are as if confounded in the crystallization of one and the same mineral.

In short, as if the results of this operation of Nature were destined to excite astonishment of every kind, while one and the same substance lends itself to so many transformations, we meet very different substances, which present absolutely the same form. Thus fluated lime, muriated soda, sulphuretted iron, sulphuretted lead, &c., crystallize in cubes under certain circumstances; and in other cases, the same

* This idea suggested to M. Romé de l'Isle the method of truncatures, for enabling us to derive from each other the different varieties of crystalline forms which should belong to one and the same substance.

minerals, as well as sulphated alumine and the diamond, assume the form of a regular octahedron*.

It was this similitude of forms which, at a time when the study of crystallization was scarcely in its infancy, inclined Linnæus to think that the salts should be regarded as the generators of crystallization; that the union of any given salt with a given kind of stone was a sort of fecundation which communicated to the stone the property of crystallizing under the form peculiar to the salt which performed the function of the fecundating principle †. The diamond, for instance, he considered as a species of alum, because it crystallizes like the latter, and he gave it the name of *alumen adamas* †. Thus Linnæus thought he found in the mineral kingdom the basis of the sexual system, of which he made so advantageous an use in Botany. We know that Tournefort, on observing the ramified stalactites of the Grotto of Antiparos, imagined that stones vegetated in the same way as plants. Botany was the favourite study of these two celebrated men, and all Nature, in their opinion, spoke the language of their favourite study.

Linnæus subjoined to his work some descriptions and figures of crystals, which were sufficiently accurate, considering the state of science at the time; and in this respect he may be regarded as the founder of crystallography.

Latterly, Romé de l'Isle has referred the study of crystallization to principles more and more conformable to observation. He arranged together, as far as possible, crystals of the same nature. Among the different forms relative to each species, he chose one as the most proper, from its simplicity, to be regarded as the primitive form; and by supposing it truncated in different ways, he deduced the other forms from it, and determined a gradation, a series of transitions between this same form and that of polyhedrons, which seemed to be still further removed from it. To the descriptions and figures which he gave of the crystalline forms, he added the results of the mechanical measurement

* We shall presently explain the reasons which can assist us in conceiving the nature of this resemblance in configuration between minerals of various descriptions.

† *Linnæi Amœnit. Acad.* tome i. p. 466 & seq.

‡ The learned author of this classification was well aware that, among the bodies which he associated under one and the same species, several presented a form different from that which was the type of the species. But he tried to bring them to this last form according to some vague traces of resemblance which he caught from their external aspect; and as but a very small number of crystalline forms had been at that time observed, the most of them extremely simple, these similarities, which would have been impracticable in the present advanced state of science, were then of less difficult classification.

of their principal angles, and showed (what was a very essential point) that these angles were constant in each variety. In a word, his crystallography is the production of a very extensive and highly useful course of study.

The illustrious Bergman, by endeavouring to penetrate to the mechanism of the structure of crystals, considered the different forms relative to one and the same substance as produced by a superposition of planes, sometimes constant and sometimes variable, and decreasing around one and the same primitive form. He applied this primitive idea to a small number of crystalline forms, and verified it with respect to a variety of calcareous spar* by fractures, which enabled him to ascertain the position of the nucleus, or of the primitive form, and the successive order of the laminæ covering this nucleus. Bergman, however, stopped here, and did not trouble himself either with determining the laws of structure, or applying calculation to it. It was a simple sketch, drawn *en passant*, of the most prominent point of view in mineralogy, but in which we see the hand of the same master who so successfully filled up the outlines of chemistry.

In the researches which I undertook about the same period on the structure of crystals †, I proposed combining the form and dimensions of integrant molecules with simple and regular laws of arrangement, and submitting these laws to calculation. This work produced a mathematical theory, which I reduced to analytical formulæ, representing every possible case, and the application of which to known forms leads to valuations of angles constantly agreeing with observation. I shall explain the principles of this theory by the help of reasoning alone, and of some projections which will facilitate their explanation. Geometricians may acquire a more correct and more detailed knowledge of the subject by perusing the calculations which are given separately in this work.

THEORY OF THE STRUCTURE OF CRYSTALS.

Primitive Forms.—The idea of referring to one of the same primitive forms all the forms which may be assumed by a mineral substance, of which the rest may be regarded as being modifications only, has frequently suggested itself to various naturalists who have made crystallography their study. It was in consequence of having regarded it in a false point

* This is what has been called *dent de cochon*, but which I call *metastatic*.

† The members of the Academy of Sciences were acquainted with my first Essays on this subject, when they received Bergman's Memoir, which was communicated to me as being interesting.

of view that Linnæus was led astray in his methodical distribution of crystals. Romé de l'Isle, by employing it with more art and justice, avoided the breaches of natural connections which disfigure the system of the Swedish naturalist. But there was something arbitrary in the choice of the forms which De l'Isle regarded as primitive, by consulting only the external aspect of crystals, without regarding their structure. Bergman, who had so successfully seized the nucleus of carbonated lime, by mechanically dividing the metastatic crystal, was not equally fortunate with respect to several other crystals, and in particular with respect to the dodecahedron variety of the same substance which was then called *tête de clou* (nail head). It would result from the explanation which he gives of the structure of this crystal, that its nucleus should have angles totally different from those of the true; and Bergman has even been obliged to suppose that the planes which he calls *fundamental* were truncated in the present case, which presented a new exception to the principle on which his system was founded*.

The mechanical division of minerals, which is the only method of ascertaining their true primitive form, proves that this form is invariable while we operate upon the same substance, however diversified or dissimilar the forms of the crystals belonging to this substance may be. Two or three examples will serve to place this truth in its proper light.

Take a regular hexahedral prism of carbonated lime (Pl. I. figs. 1 and 2). If you try to divide it parallel to the edges which form the contours of the bases, you will find that three of these edges taken alternately in the upper part, for instance, the edges lf , cd , bm , may be referred to this division: and in order to succeed in the same way with respect to the inferior base, we must choose, not the edges $l'f'$, $c'd'$, $b'm'$, which correspond with the preceding, but the intermediate edges $d'f'$, $l'c'$, $b'm'$.

The six sections will uncover an equal number of trapeziums. Three of the latter are represented upon fig. 2, viz. the two which intercept the edges lf , cd , and are designated by $ppoo$, $aukk$, and that which intercepts the lower edge $d'f'$, and which is marked by the letters $nnii$.

Each of these trapeziums will have a lustre and polish, from which we may easily ascertain that it coincides with one of the natural joints of which the prism is the assemblage. You may attempt in vain to divide the prism in any other direction. But if you continue the division parallel

* See the remarks on this head in my Essay towards a Theory of the Structure of Crystals.—See Philosophical Magazine, vol. i. p. 35 et seq.

to the first sections, it will happen that on one hand the surfaces of the bases will always become narrower, while on the other hand the altitudes of the panes will decrease; and at the term at which the bases have disappeared, the prism will be changed into a dodecahedron (fig. 3,) with pentagonal faces, six of which, such as $ooiOe$, $ol kii$, &c., will be the residues of the panes of the prism; and the six others $EAIoo$, $OA'Kii$, &c. will be the immediate result of the mechanical division*.

Beyond this same term, the extreme faces will preserve their figure and dimensions, while the lateral faces will incessantly diminish in height, until the points o , k , of the pentagon $ol kii$, coming to be confounded with the points i , i , and so on with the other points similarly situated, each pentagon will be reduced to a simple triangle, as we see in fig. 4. †

Lastly, when new sections have obliterated these triangles, so that no vestige of the surface of the prism remains, (fig. 1,) you will have the nucleus or the primitive form, which will be an obtuse rhomboid ‡, (fig. 5,) the grand angle of which EAI or EOI is $101^{\circ} 32' 13''$ §.

The observation I have detailed is that which served for developing my ideas on the structure of crystals, and has been the key of the theory: it occurred to me on the occasion of a crystal being presented to me by citizen De-france from his mineralogical collection. The prism had a single fracture at the place of one of the edges situated around the base, by which it had adhered to the remains of the group. Instead of placing it in my collection, I tried to divide it in other directions; and I succeeded after some

* We have continued to represent the hexahedral prism circumscribed by the solid from which we extract it, by dividing it, in order that the progress of the operation may be more easily conceived.

† The points which are confounded, two and two, upon this figure are each marked with the two letters which served to designate them when they were separated, as in fig. 3.

‡ I denominate as a *rhomboid* a parallelepipedon, terminated by six equal and similar rhombuses. Two of the solid angles, such as A , A' , opposed to each other, are formed by the union of three equal plane angles. Each of the six others is formed by a plane angle equal to the preceding ones, and by two angles which are supplements to them. The points A , A' , are the summits, and the line which proceeds from the one to the other is the axis. We always suppose the rhomboid situated so as to make its axis vertical. In any single face, such as $AEOI$, the line drawn from E to I is the horizontal diagonal, and that from A to O is the oblique diagonal. The rhomboid is obtuse or acute, accordingly as the angle contiguous to the summit is itself obtuse or acute.

§ I have observed that each trapezium, such as $ppoo$ (fig. 2,) uncovered by the first sections, was very sensibly inclined from the same quantity, as well upon the residue $ppdebm$ of the base, as upon the residue $oo f' l'$ of the adjacent pane. Setting out from this equality of inclinations, we deduce from it by calculation the value of the angles with the precision of minutes and seconds, which mechanical measurements are not capable of attaining.

ineffectual attempts in extracting its rhomboidal nucleus, which excited my surprise, mixed with the hope that I might succeed still further.

Let us take as a second example—the metastatic crystal (fig. 6,) the nucleus of which was found by Bergman. You may obtain this nucleus speedily by making a first section upon the edges EO, OI; a second upon the edges IK, GK; a third upon GH, EH; a fourth upon OI, IK; a fifth upon GK, GH; lastly, a sixth upon EH, EO; whence it follows, that the edges of which we are speaking are confounded with the lateral edges of the primitive form, as we may judge from a simple inspection of fig. 7, which represents this primitive form inscribed in the dodecahedron with scalene triangles.

There exist many other varieties of carbonated lime, several of which have very compound forms, and all of them contain a nucleus precisely similar to that under consideration. But if it be singular to see this nucleus issue from varieties which are removed from it mostly by their configuration, we have far less reason to expect it in those which of themselves have a rhomboidal form with different measurements of angles. We are at present acquainted with five of these rhomboids*, one of which is much more obtuse than the nucleus, and the four others have summits always more acute. This gradation, all the terms of which are referred to one and the same species of solid, would seem at first sight to give some colour to the opinion that primitive forms are not constant relative to one and the same mineral. But I have ascertained that all these rhomboids concur in exhibiting, by sections made in different directions, a nucleus similar to that whose grand angle is $101^{\circ} 32'$; and thus the paradox which arises from the diversity of their angles is cleared up by the double employment

* Beginning with that which is obtuse, we have the following values for the plane angle of the summit:

114°	18'	56"
87	42	30
75	31	20
45	34	22
37	31	4

Mineralogists for a long period have only been acquainted with the first and third of these rhomboids. We see from Bergman's memoir, which I have already quoted, that he confounded the rhomboid $114^{\circ} 18'$ with the primitive, in which the angle of the summits is $101^{\circ} 32'$. On the other hand, Romé de l'Isle considered that of $75^{\circ} 31'$ as a second primitive form of calcareous spars, because he saw no method of referring it, even by truncatures, to that of $101^{\circ} 32'$. See Bergman's work on the character of minerals.—*Tableau Lithologique.*

of the rhomboidal form which serves here to disguise itself, and conceals fixed characters under variable outsides.

Let us choose for instance, among these different rhomboids, that in which the angle at the summit is $75^{\circ} 31' 20''$, and which is represented fig. 8, circumscribed to its nucleus. Romé de l'Isle called it muriatic calcareous spar, and I denominate it *inverse carbonated lime*. In order to divide this rhomboid mechanically, the secting planes must be directed parallel to the six extreme edges; viz. st, su, sn , on one hand, and st', su', sn' , on the other, in such a way that these planes are equally inclined upon the faces which they cut into. The first sections will exhibit six pentagons $rrr'r'r'$ (fig. 9), parallel to the faces of the nucleus; and it is easy to conceive, that by continuing the division always in the same direction, until the residues of the faces of the rhomboid AA' (fig. 8) have disappeared, we shall have a new rhomboid, which will be the primitive form.

We may remark, that the faces of this last rhomboid are inclined in the same quantity upon the common axis, with the edges st, su, sn , &c., to which these faces are parallel. Now the edges in question form with the axis larger angles than the oblique diagonals drawn from s to n' , from s to t' , from s to u' , or, what comes to the same thing, than the faces $stn'u, sn't'u, st'u'n$; whence we conclude that in the rhomboid, extracted by mechanical division, the angle of the summit should be sensibly more open than that which corresponds with it in the divided rhomboid. From what has been said above, this last angle is smaller than the other by $26^{\circ} 0' 53''$.

If we try to divide a crystal of another species, you will have a different nucleus. For instance, a cube of fluated lime will give a regular octahedron, which you will succeed in extracting by dividing the cube upon its eight solid angles, which will in the first place discover eight equilateral triangles, and by pursuing the division, always parallel to the first sections, until nothing more remains of the faces of the cube, the nucleus of the crystals of sulphated barytes will be a straight prism with rhombous bases; that of the crystals of phosphated lime a regular hexahedral prism; that of sulphuretted lead a cube, &c.; and each of these forms will be constant relative to the entire species, in such a manner that its angles will not undergo any appreciable variation.

With regard to crystals which refuse to be mechanically divided, the theory seconded by certain indications, which
we

we shall presently speak of, may lead to the determination of their primitive forms, at least with a great probability of accuracy.

Having adopted the word *primitive form*, in order to designate the nucleus of crystals, we shall call *secondary forms* such varieties as differ from the primitive form.

In certain species, crystallization also produces this last form immediately. There exist, for example, calcareous crystals which differ in no respect from the rhomboid which we extract from the regular hexahedral prism, and from the other varieties which we have mentioned. Besides, it frequently happens also, that among the faces of a secondary crystal there are some which are parallel to those of the primitive form. Thus we find crystals of carbonated lime, which are similar to that of fig. 3, and on which crystallization has left pentagonal planes, such as $A E o o I$, $A E h h G$, &c., situated like those which we expose by dividing the hexahedral prism represented in fig. 1. In such cases as these, the route is as it were traced out before hand, previous to arriving at the nucleus.

We may define the primitive form a solid of a constant form, engaged symmetrically in all the crystals of one and the same species, and the faces of which follow the directions of the laminæ which form these crystals.

The primitive forms hitherto observed are reduced to six, viz.: the parallelepipedon, the octahedron, the tetrahedron, the regular hexahedral prism, the dodecahedron with rhombous planes, all equal and similar, and the dodecahedron with triangular planes, composed of two straight pyramids joined base to base.

Forms of integrant Molecules.—The nucleus of a crystal is not the last term of its mechanical division. It may always be subdivided parallel to its different faces, and sometimes in other directions also. The whole of the surrounding substance is capable of being divided by strokes parallel to those which take place with respect to the primitive form. Reasoning here as we have done with respect to the mechanical division of common salt, we conclude that the limit of the mechanical division which we may operate in any given crystal, ought to give the form of the integrant molecule peculiar to the kind of mineral of which this crystal is the primitive.

If the nucleus be a parallelepipedon which cannot be subdivided except by blows parallel to its faces, like that which takes place with respect to carbonated lime, it is evident that the integrant molecule will be similar to this nucleus itself.

But it may happen that the parallelepipedon admits of
further

further sections in other directions than the former. Let us conceive for example, that it is a rhomboid $A A' K H$ (fig. 10), directly divisible parallel to the six rhombuses which terminate it, and with the help of planes, each of which passes by an oblique diagonal $A O$, by the axis $A' A$, and by the edge $A' O$, comprehended between the same diagonal and the axis. These sections will detach six tetrahedrons, which have been figured separately around the rhomboid, in positions analogous to those which they had when joined in one single body, in such a way that we follow as it were with the eye the species of decomposition of the rhomboid from which they proceed. Now these tetrahedrons represent the integrant molecules of the substance of which the rhomboid is the primitive form. Such is the structure of the tourmaline.

Let us take another substance, such as phosphated lime, the primitive form of which is the regular hexahedral prism. In this case the molecule will be still different from the nucleus, although this last cannot be subdivided except parallel with its faces, *i. e.* with its two bases and its six planes. This subdivision will lead us to triangular prisms, the assemblage of which composes the entire prism, as may easily be perceived by inspecting fig. 40, Pl. V; we there see one of the bases of the prism divided into equilateral triangles, each of which is the base of a small triangular prism which represents the integrant molecule.

Now we shall presently find that we may reduce the forms of the integrant molecules of all crystals to the three preceding forms, which are the tetrahedron, or the simplest of the pyramids: the triangular prism, or the simplest of all the prisms; and the parallelepipedon, or the simplest among the solids, which have their faces parallel two and two. And since four planes at least are necessary for circumscribing a space, it is evident that the three forms in question, in which the number of faces is successively four, five, and six, have still, in this respect, the greatest possible simplicity. If these forms, I repeat, are not those of the true integrant molecules employed by Nature, they deserve at least to supply their place in our conceptions, the more especially as it is with but very scanty materials that we succeed in establishing a theory which embraces so many various results.

Several naturalists have thought that the integrant molecules of crystals were simple laminae, whose thickness was incomparably less than their other dimensions, and not small solids, the thickness of which was equal, or at least in proportion to their breadth and length. In the *Journal des Mines*, No. 28, p. 305, I have detailed the numerous
and

and decisive proofs which confirm this last opinion, and I have even demonstrated that the dimensions and angles of these molecules were invariable in all primitive crystals of one and the same substance. I shall not stop here again to obviate the difficulties which opposed my progress, because I have had the satisfaction of observing that the answers suggested themselves as if spontaneously to those who are in possession of the theory, and because it appears to me that this theory has been taken up by the only author who studied it in the same points of view with myself*.

But every form of the integrant molecule varies in its dimensions, or in the measurement of its angles, according to the species to which it belongs†. The parallelepipedon is sometimes oblique-angled, and sometimes right-angled: sometimes it presents the form of the rhomboid, and at other times that of the cube, which is the most perfect among the forms of this kind. In some cases the triangular prism is merely isoscele; in other cases it is equilateral; and in this last case, the relation between its height and the side of its base varies in both species. The tetrahedron undergoes analogous diversities.

There exist, however, forms of integrant molecules, as well as primitive forms which are common to several substances of diverse natures. For example, muriated soda and sulphuretted iron both have the cube as their primitive form. The regular octahedron is that of the ruby, and at the same time that of native bismuth. In this case the elementary molecules, although different in all respects, are so arranged that there results the same external configuration nearly; as in geometry, we may compose a square in several ways by assortments of figures which will differ from each other in the various squares. Besides, if observation has proved that mineral substances, distinct in their nature, sometimes exhibit secondary crystals of the same form, (for instance, regular hexahedral prisms with a diversity of structure which would suppose one in the forms of the molecules themselves) ought we to be surprised also to find in different species integrant molecules, the forms of which, similar externally, are owing to combinations of principles which cannot have any relation with each other? But it is worthy of attention that hitherto these forms common to several minerals were always those which have a remarkable character for simplicity

* *Théorie de la Terre, par Lametherie, 2d edit. tome i. p. 35 et seq.*

† Observation only makes known the measurements of angles, and not the reference of dimensions; theory, however, furnishes us with data for determining the latter.

and regularity, such as the cube, the regular octahedron, the dodecahedron with rhombous planes all equal and similar, &c. These forms are kinds of limits which crystallization attains by different routes; while, with respect to other forms quite different from those limits, it has a single direction only which ends in any particular species of mineral.

Laws to which the Structure is subjected.—After having determined the primitive forms, and those of the integrant molecules, it remains to inquire for the laws pursued by these molecules in their arrangement, in order to produce these regular kinds of envelopes, which disguise one and the same primitive form in so many different ways.

Now observation shows that this surrounding matter is an assemblage of laminæ, which, setting out from the primitive form, decrease in extent, both on all sides at once, and sometimes in certain particular parts only. This decrement is effected by regular subtractions of one or more rows of integrant molecules; and the theory, in determining the number of these rows by means of calculation, succeeds in representing all the known results of crystallization, and even anticipates future discoveries indicating forms which, being still hypothetical only, may one day be presented to the inquiries of the naturalist.

Some very simple examples will serve for giving an idea of the laws to which the decrements in question are subjected.

[To be continued.]

XV. *The Bakerian Lecture. An Account of some new analytical Researches on the Nature of certain Bodies, particularly the Alkalies, Phosphorus, Sulphur, Carbonaceous Matter, and the Acids hitherto undecomposed; with some general Observations on Chemical Theory.* By HUMPHRY DAVY, Esq., Sec. R.S., F.R.S. Edin., and M.R.I.A.

[Continued, from p. 19.]

IV. *Analytical Experiments on Phosphorus.*

THE same analogies apply to phosphorus as to sulphur, and I have made a similar series of experiments on this inflammable substance.

Common electrical sparks, passed through phosphorus, did not evolve from it any permanent gas; but when it was acted upon by the Voltaic electricity of the battery of five hundred plates in the same manner as sulphur, gas was produced in considerable quantities, and the phosphorus be-
came

came of a deep red brown colour, like phosphorus that has been inflamed and extinguished under water. The gas examined proved to be phosphuretted hydrogen, and in one experiment, continued for some hours, a quantity estimated to be nearly equal to four times the volume of the phosphorus employed was given off. The light of the Voltaic spark in the phosphorus was at first a brilliant yellow, but as the colour of the phosphorus changed, it appeared orange.

I heated three grains of potassium in sixteen cubical inches of phosphuretted hydrogen; as soon as it was fused, the retort became filled with white fumes, and a reddish substance precipitated upon the sides and upper part of it. The heat was applied for some minutes. No inflammation took place*. When the retort was cool, the absorption was found to be less than a cubical inch. The potassium externally was of a deep brown colour, internally it was of a dull lead colour. The residual gas had lost its property of spontaneous inflammation, but seemed still to contain a small quantity of phosphorus in solution.

The phosphuret acted upon over mercury by solution of muriatic acid evolved only one cubical inch and three quarters of phosphuretted hydrogen.

From this experiment, there is great reason to suppose that phosphuretted hydrogen contains a minute proportion of oxygen, and consequently that phosphorus likewise may contain it; but the action of potassium on phosphorus itself furnishes perhaps more direct evidences of the circumstance.

One grain of potassium and one grain of phosphorus were fused together in a proper apparatus. They combined with the production of the most vivid light and intense ignition. During the process one-tenth of a cubical inch of phosphuretted hydrogen was evolved. The phosphuret formed, exposed to the action of diluted muriatic acid over mercury, produced exactly three-tenths of a cubical inch of phosphuretted hydrogen.

In a second experiment, one grain of potassium was fused with three grains of phosphorus; in this case nearly a quarter of a cubical inch of phosphuretted hydrogen was generated during the ignition. But from the compound exposed to muriatic acid, only one-tenth of a cubical inch could be procured.

Now it is not easy to refer the deficiency of phosphuretted

* It is stated, in the account before referred to of MM. Gay Lussac's and Thenard's experiments, that potassium inflames in phosphuretted hydrogen. My experiments upon this gas have been often repeated. I have never perceived any luminous appearance; but I have always operated in daylight.

hydrogen in the second case to any other cause than to the supply of oxygen to the potassium from the phosphorus; and the quantity of phosphuretted hydrogen evolved in the first case, is much less than could be expected, if both potassium and phosphorus consisted merely of pure combustible matter.

The phosphoric acid, formed by the combustion of phosphorus, though a crystalline solid, may still contain water. The hydrogen evolved from phosphorus by electricity proves indeed that this must be the case; and though the quantity of hydrogen and oxygen in phosphorus may be exceedingly small, yet they may be sufficient to give it peculiar characters; and till the basis is obtained free, we shall have no knowledge of the properties of the pure phosphoric element.

V. *On the States of the carbonaceous Principle in Plumbago, Charcoal, and the Diamond.*

The accurate researches of Messrs. Allen and Pepys have distinctly proved, that plumbago, charcoal, and the diamond, produce very nearly the same quantities of carbonic acid, and absorb very nearly the same quantities of oxygen in combustion.

Hence it is evident, that they must consist principally of the same kind of elementary matter; but minute researches upon their chemical relations, when examined by new analytical methods, will, I am inclined to believe, show that the great difference in their physical properties does not merely depend upon the differences of the mechanical arrangement of their parts, but likewise upon differences in their intimate chemical nature.

I endeavoured to discover, whether any elastic matter could be obtained from plumbago very intensely ignited by the Voltaic battery in a Torricellian vacuum: but though the highest power of the battery of five hundred was employed, and though the heat was such, as in another experiment instantly melted platina wire of $\frac{1}{80}$ th of an inch in diameter, yet no appearance of change took place upon the plumbago. Its characters remained wholly unaltered, and no permanent elastic fluid was formed.

I heated one grain of plumbago, with twice its weight of potassium, in a plate glass tube connected with a proper apparatus, and I heated an equal quantity of potassium alone in a tube of the same kind, for an equal length of time, namely, eight minutes. Both tubes were filled with hydrogen: no gas was evolved in either case. There was no igni-
tion

tion in the tube containing the plumbago, but it seemed gradually to combine with the potassium. The two results were exposed to the action of water; the result from the plumbago acted upon that fluid with as much energy as the other result, and the two volumes of elastic fluids were 1.8 cubical inches and 1.9 cubical inches; and both gave the same diminution by detonation with oxygen, as pure hydrogen. Two grains of potassium, by acting upon water, would have produced two cubical inches and one-eighth of hydrogen gas; the deficiency in the result, in which potassium alone was used, must be ascribed to the loss of a small quantity of metal, which must have been carried off in solution in the hydrogen, and perhaps, likewise, to the action of the minute quantity of metallic oxides in the plate glass. The difference in the quantity of hydrogen given off in the two results, is however too slight to ascribe it to the existence of oxygen in the plumbago.

I repeated this experiment several times with like results, and in two or three instances examined the compound formed. It was infusible at a red heat, had the lustre of plumbago. It inflamed spontaneously, when exposed to air, generated potash, and left a black powdery residuum. It effervesced most violently in water, and produced a gas, which burnt like pure hydrogen.

When small pieces of charcoal from the willow, that had been intensely ignited, were acted upon by Voltaic electricity in a Torricellian vacuum, every precaution being taken to exclude moisture from the mercury and the charcoal, the results were very different from those occurring in the case of plumbago.

When plumbago was used, after the first spark, which generally passed through a distance of about one-eighth of an inch, there was no continuation of light, without a contact or an approach to the same distance; but from the charcoal a flame seemed to issue of a most brilliant purple, and formed, as it were, a conducting chain of light of nearly an inch in length, at the same time that elastic matter was rapidly formed, some of which was permanent. After many unsuccessful trials, I at length succeeded in collecting the quantity of elastic fluid given out by half a grain of charcoal; the process had been continued nearly half an hour. The quantity of gas amounted to nearly an eighth of a cubical inch; it was inflammable by the electric spark with oxygen gas, and four measures of it absorbed three measures of oxygen, and produced one measure and a half of carbonic acid. The charcoal in this experiment had
become

become harder at the point, and its lustre, where it had been heated to whiteness, approached to that of plumbago.

I heated two grains of potassium together with two grains of charcoal, for five minutes; and to estimate the effects of the metallic oxides and potash in the green glass tube, I made a comparative experiment, as in the case of plumbago; but there was no proof of any oxygen being furnished to the potassium from the charcoal in the process, for the compound acted upon water with great energy, and produced a quantity of inflammable gas, only inferior by one-twelfth to that produced by the potassium, which had not been combined with charcoal, and which gave the same diminution by detonation with oxygen; and the slight difference may be well ascribed to the influence of foreign matters in the charcoal. There was no ignition in the process, and no gas was evolved.

The compound produced in other experiments of this kind was examined. It is a conductor of electricity, is of a dense black, inflames spontaneously, and burns with a deep red light in the atmosphere*.

The non-conducting nature of the diamond, and its infusibility, rendered it impossible to act upon it by Voltaic electricity; and the only new agents which seemed to offer any means of decomposing it, were the metals of the alkalis.

When a diamond is heated in a green glass tube with potassium, there is no elastic fluid given out, and no intensity of action; but the diamond soon blackens, and scales seem to detach themselves from it; and these scales, when examined in the magnifier, are gray externally, and of the colour of plumbago internally, as if they consisted of plumbago covered by the gray oxide of potassium.

In heating together three grains of diamonds in powder, and two grains of potassium, for an hour in a small retort of plate glass filled with hydrogen, and making the comparative trial with two grains of potassium heated in a similar apparatus, without any diamonds, I found that the potassium which had been heated with the diamonds, produced, by its action upon water, one cubical inch and $\frac{2}{10}$ ths of inflammable air, and that which had been exposed to heat alone, all other circumstances being similar, evolved nearly one cubical inch and $\frac{7}{10}$ ths, both of which were pure hydrogen.

* In the Bakerian Lecture for 1807, I have mentioned the decomposition of carbonic acid by potassium, which takes place with inflammation. If the potassium is in excess in this experiment, the same pyrophorus as that described above is formed.

In another experiment of a similar kind, in which fragments of diamonds were used in the quantity of four grains, the potassium became extremely black from its action upon them during an exposure to heat for three hours, and the diamonds were covered with a grayish crust, and when acted upon by water and dried, were found to have lost about $\frac{1}{1000}$ ths of a grain in weight. The matter separated by washing, and examined, appeared as a fine powder of a dense black colour. When a surface of platina wire was covered with it, and made to touch another wire in the Voltaic circuit, a brilliant spark with combustion occurred. It burnt, when heated to redness in a green glass tube filled with oxygen gas, and produced carbonic acid by its combustion.

These general results seem to show, that in plumbago the carbonaceous element exists merely in combination with iron, and in a form which may be regarded as approaching to that of a metal in its nature, being conducting in a high degree, opaque, and possessing considerable lustre.

Charcoal appears to contain a minute quantity of hydrogen in combination. Possibly likewise, the alkalies and earths produced during its combustion, exist in it not fully combined with oxygen; and according to these ideas, it is a very compounded substance, though in the main it consists of the pure carbonaceous element.

The experiments on the diamond render it extremely likely that it contains oxygen; but the quantity must be exceedingly minute, though probably sufficient to render the compound non-conducting: and if the carbonaceous element in charcoal and the diamond be considered as united to still less foreign matter in quantity, than in plumbago, which contains about $\frac{1}{10}$ th of iron, the results of their combustion, as examined independently of hygrometrical tests, will not differ perceptibly.

Whoever considers the difference between iron and steel, in which there does not exist more than $\frac{1}{1000}$ th of plumbago, or the difference between the amalgam of ammonium, and mercury, in which the quantity of new matter is not more than $\frac{1}{121000}$ th, or that between the metals and their suboxides, some of which contain less than $\frac{1}{10}$ th of oxygen, will not be disposed to question the principle, that minute differences in chemical composition may produce great differences in external and physical characters.

VI. *Experiments on the Decomposition and Composition of the Boracic Acid.*

In the last Bakerian Lecture, I have given an account of
 Vol. 34. No. 136. August 1809. H an

an experiment in which boracic acid appeared to be decomposed by Voltaic electricity, a dark-coloured inflammable substance separating from it on the negative surface.

In the course of the spring and summer, I made many attempts to collect quantities of this substance for minute examination. When boracic acid, moistened with water, was exposed between two surfaces of platina, acted on by the full power of the battery of five hundred, an olive-brown matter immediately began to form on the negative surface, which gradually increased in thickness, and at last appeared almost black. It was permanent in water, but soluble with effervescence in warm nitrous acid. When heated to redness upon the platina it burnt slowly, and gave off white fumes, which slightly reddened moistened litmus paper, and it left a black mass, which, when examined by the magnifier, appeared vitreous at the surface, and evidently contained a fixed acid.

These circumstances seemed distinctly to show the decomposition and recomposition of the boracic acid; but as the peculiar combustible substance was a non-conductor of electricity, I was never able to obtain it, except in very thin films upon the platina. It was not possible to examine its properties minutely, or to determine its precise nature, or whether it was the pure boracic basis; I consequently endeavoured to apply other methods of decomposition, and to find other more unequivocal evidences upon this important chemical subject.

I have already laid before the Society an account of an experiment *, in which boracic acid, heated in contact with potassium in a gold tube, was converted into borate of potash, at the same time that a dark-coloured matter, similar to that produced from the acid by electricity, was formed. About two months after this experiment had been made, namely, in the beginning of August, at a time that I was repeating the process, and examining minutely the results, I was informed, by a letter from Mr. Cadell at Paris, that M. Thenard was employed in the decomposition of the boracic acid by potassium, and that he had heated the two substances together in a copper tube, and had obtained borate of potash, and a peculiar matter concerning the nature of which no details were given in the communication.

That the same results must be obtained by the same methods of operating, there could be no doubt. The evidences for the decomposition of the boracic acid are easily gained,

* Philosophical Transactions, Part II, for 1808, p. 343.

the synthetical proofs of its nature involve more complicated circumstances.

I found that when equal weights of potassium and boracic acid were heated together in a green glass tube, which had been exhausted after having been twice filled with hydrogen, there was a most intense ignition before the temperature was nearly raised to the red heat; the potassium entered into vivid inflammation, where it was in contact with the boracic acid. When this acid had been heated to whiteness, before it was introduced into the tube, and powdered and made use of whilst yet warm, the quantity of gas given out in the operation did not exceed twice the volume of the acid, and was hydrogen.

I could only use twelve or fourteen grains of each of the two substances in this mode of conducting the experiment; for when larger quantities were employed, the glass tube always ran into fusion from the intensity of the heat produced during the action.

When the film of naphtha had not been carefully removed from the potassium, the mass appeared black throughout; but when this had been the case, the colour was of a dark olive-brown.

In several experiments, in which I used equal parts of the acid and metal, I found that there was always a great quantity of the former in the residuum; and by various trials, I ascertained that twenty grains of potassium had their inflammability entirely destroyed by about eight grains of boracic acid.

For collecting considerable portions of the matters formed in the process, I used metallic tubes furnished with stop-cocks, and exhausted after being filled with hydrogen.

When tubes of brass or copper were employed, the heat was only raised to a dull red; but when iron tubes were used, it was pushed to whiteness. In all cases the acid was decomposed, and the products were scarcely different.

When the result was taken out of a tube of brass or copper, it appeared as an olive-coloured glass, having opaque, dull olive-brown specks diffused through it.

It gave a very slight effervescence with water, and partially dissolved in hot water, a dark olive-coloured powder separating from it.

The results from the iron tube, which had been much more strongly heated, were dark olive in some parts, and almost black in others. They did not effervesce with warm water, but were rapidly acted upon by it, and the particles

separated by washing were of a shade of olive, so dark as to appear almost black on white paper.

The solutions obtained, when passed through a filter, had a faint olive tint, and contained sub-borate of potash, and potash. In cases when, instead of water, a weak solution of muriatic acid was used for separating the saline matter from the inflammable matter, the fluid came through the filter colourless.

In describing the properties of the new inflammable substance separated by washing, I shall speak of that collected from operations conducted in tubes of brass, in the manner that has been just mentioned; for it is in this way that I have collected the largest quantities.

It appears as a pulverulent mass of the darkest shades of olive. It is perfectly opaque. It is very friable, and its powder does not scratch glass. It is a non-conductor of electricity.

When it has been dried only at 100 or 120°, it gives off moisture by increase of temperature, and if heated in the atmosphere, takes fire at a temperature below the boiling point of olive oil, and burns with a red light and scintillations like charcoal.

If it be excluded from air and heated to whiteness in a tube of platina, exhausted after having been filled with hydrogen, it is found very little altered after the process. Its colour is a little darker, and it is rather denser; but no indications are given of any part of it having undergone fusion, volatilization, or decomposition. Before the process its specific gravity is such that it does not sink in sulphuric acid; but after, it rapidly falls to the bottom in this fluid.

The phenomena of its combustion are best witnessed in a retort filled with oxygen gas. When the bottom of the retort is gently heated by a spirit lamp, it throws off most vivid scintillations like those from the combustion of the bark of charcoal, and the mass burns with a brilliant light. A sublimate rises from it, which is boracic acid; and it becomes coated with a vitreous substance, which proves likewise to be boracic acid; and after this has been washed off, the residuum appears perfectly black, and requires a higher temperature for its inflammation than the olive-coloured substance; and by its inflammation produces a fresh portion of boracic acid.

In oxymuriatic acid gas, the peculiar inflammable substance occasions some beautiful phenomena. When this gas is brought in contact with it at common temperatures,

it instantly takes fire and burns with a brilliant white light, a white substance coats the interior of the vessel in which the experiment is made, and the peculiar substance is found covered by a white film, which, by washing, affords boracic acid, and leaves a black matter, which is not spontaneously inflammable in a fresh portion of the gas; but which inflames in it by a gentle heat, and produces boracic acid.

The peculiar inflammable substance, when heated nearly to redness in hydrogen, or nitrogen, did not seem to dissolve in these gases, or to act upon them; it merely gained a darker shade of colour, and a little moisture rose from it, which condensed in the neck of the retort in which the experiment was made.

On the fluid menstrua containing oxygen, it produced effects which might be looked for from the phenomena of its agency on gases.

When thrown into concentrated nitric acid, it rendered it bright red, so that nitrous gas was produced and absorbed, but it did not dissolve rapidly till the acid was heated; when there was a considerable effervescence, the peculiar substance disappeared, nitrous gas was evolved, and the fluid afforded boracic acid.

It did not act upon concentrated sulphuric acid till heat was applied; it then produced a slight effervescence; the acid became black at its points of contact with the solid; and a deep brown solution was formed, which, when neutralized by potash, gave a black precipitate.

When heated in a strong solution of muriatic acid, it gave it a faint tint of green; but there was no vividness of action, or considerable solution.

On acetic acid heated, it had no perceptible action.

It combined with the fixed alkalies, both by fusion and aqueous solution, and formed pale olive-coloured compounds, which gave dark precipitates when decomposed by muriatic acid.

When it was kept long in contact with sulphur in fusion, it slowly dissolved, and the sulphur acquired an olive tint. It was still less acted upon by phosphorus, and after an hour's exposure to it, had scarcely diminished in quantity, but the phosphorus had gained a tint of pale green.

It did not combine with mercury, when they were heated together.

These circumstances are sufficient to show, that the combustible substance obtained from boracic acid by the agency of potassium, is different from any other known species of matter, and it seems, as far as the evidence extends, to be

the same as that procured from it by electricity; and the two series of facts seem fully to establish the decomposition and recomposition of the acid.

From the large quantity of potassium required to decompose a small quantity of the acid, it is evident that the boracic acid must contain a considerable proportion of oxygen. I have endeavoured to determine the relative weights of the peculiar inflammable matter and oxygen, which compose a given weight of boracic acid; and to this end I made several analytical and synthetical experiments; I shall give the results of the two which I consider most accurate.

Twenty grains of boracic acid and thirty grains of potassium were made to act upon each other by heat in a tube of brass; the result did not effervesce when washed with diluted muriatic acid; and there were obtained after the process, by slight lixiviation in warm water, two grains and about $\frac{6}{10}$ ths of the olive-coloured matter. Now thirty grains of potassium would require about five grains of oxygen, to form thirty-five of potash; and according to this estimation, boracic acid must consist of about one of the peculiar inflammable substance, to nearly two of oxygen.

A grain of the inflammable substance in very fine powder, and diffused over a large surface, was set fire to in a retort, containing twelve cubical inches of oxygen; three cubical inches of gas were absorbed, and the black residuum collected after the boracic acid had been dissolved, was found to equal five-eighths of a grain. This, by a second combustion, was almost entirely converted into boracic acid, with the absorption of two cubical inches and one-eighth more of oxygen. The thermometer in this experiment was at 58° Fahrenheit, and the barometer at 30.2.

According to this result, boracic acid would consist of one of the inflammable matter, to about 1.8 of oxygen; and the dark residual substance, supposing it to be simply the inflammable matter combined with less oxygen than is sufficient to constitute boracic acid, would be an oxide, consisting of about 4.7 of inflammable matter, to 1.55 of oxygen.

These estimations I do not however venture to give as entirely correct. In the analytical experiments, there are probably sources of error, from the solution of a part of the inflammable matter, and it possibly may retain alkali, which cannot be separated by the acid. In the synthetical process, in which washing is employed, and so small a quantity of matter used, the results are still less to be depended upon; they must be considered only as imperfect approximations.

From

From the general tenour of the facts, it appears that the combustible matter obtained from boracic acid bears the same relation to that substance, as sulphur and phosphorus do to the sulphuric and phosphoric acids. But is it an elementary inflammable body, the pure basis of the acid? or is it not like sulphur and phosphorus, compounded?

Without entering into any discussion concerning ultimate elementary matter, there are many circumstances which favour the idea, that the dark olive substance is not a simple body; its being non-conducting, its change of colour by being heated in hydrogen gas, and its power of combining with the alkalies; for these properties in general belong to primary compounds, that are known to contain oxygen.

I heated the olive-coloured substance with potassium, there was a combination, but without any luminous appearance, and a gray metallic mass was formed; but from the effect of this upon water, I could not affirm that any oxygen had been added to the metal, the gas given off had a peculiar smell, and took up more oxygen by detonation than pure hydrogen, from which it seems probable, that it held some of the combustible matter in solution.

It occurred to me, that if the pure inflammable basis were capable of being deoxygenated by potassium, it would probably possess a stronger affinity for oxygen than hydrogen, and therefore be again brought to its former state by water. I made another experiment on the operation of potassium, on the olive-coloured substance, and exposed the mixture to a small quantity of ether, hoping that this might contain only water enough to oxygenate the potassium; but the same result occurred as in the last case; and a combination of potash and the olive-coloured substance was produced, insoluble in ether.

I covered a small globule of potassium, with four or five times its weight of the olive-coloured matter, in a platina tube exhausted, after being filled with hydrogen; and heated the mixture to whiteness: no gas was evolved. When the tube was cooled, naphtha was poured into it, and the result examined under naphtha. Its colour was of a dense black. It had a lustre scarcely inferior to that of plumbago. It was a conductor of electricity. A portion of it thrown into water occasioned a slight effervescence; and the solid matter separated appeared dark olive, and the water became slightly alkaline. Another portion examined, after being exposed to air for a few minutes, had lost its conducting power, was brown on the surface, and no longer produced an effervescence in water.

Some of the olive inflammable matter, with a little potassium, was heated to whiteness, covered with iron filings, a dark metalline mass was formed, which conducted electricity, and which produced a very slight effervescence in water, and gave by solution in nitric acid, oxide of iron and boracic acid.

The substance which enters into alloy with potassium, and with iron, I am inclined to consider as the true basis of the boracic acid.

In the olive-coloured matter, this basis seems to exist in union with a little oxygen; and when the olive-coloured substance is dried at common temperatures, it likewise contains water.

In the black non-conducting matter, produced in the combustion of the olive-coloured substance, the basis is evidently combined with much more oxygen, and in its full state of oxygenation it constitutes boracic acid.

From the colour of the oxides, their solubility in alkalies, and from their general powers of combination, and from the conducting nature and lustre of the matter produced by the action of a small quantity of potassium upon the olive-coloured substance, and from all analogy; there is strong reason to consider the boracic basis as metallic in its nature, and I venture to propose for it the name of *boracium*.

VII. *Analytical Inquiries respecting Fluoric Acid.*

I have already laid before the Society the account of my first experiments on the action of potassium on fluoric acid gas*.

I stated, that the metal burns when heated in this elastic fluid, and that there is a great absorption of the gas.

Since the time that this communication was made, I have carried on various processes, with the view of ascertaining, accurately, the products of combustion, and I shall now describe their results.

When fluoric acid gas, that has been procured in contact with glass, is introduced into a plate glass retort, exhausted after being filled with hydrogen gas, white fumes are immediately perceived. The metal loses its splendour, and becomes covered with a grayish crust.

When the bottom of the retort is gently heated, the fumes

* Philosophical Transactions, Part II., for 1808, p. 343. The combustion of potassium in fluoric acid I have since seen mentioned in the number of the *Moniteur* already so often quoted, as observed by MM. Gay Lussac and Thenard; but no notice is taken of the results.

become

become more copious; they continue for some time to be emitted, but at last cease altogether.

If the gas is examined at this time, its volume is found to be a little increased, by the addition of a small quantity of hydrogen.

No new fumes are produced by a second application of a low heat; but when the temperature is raised nearly to the point of sublimation of potassium, the metal rises through the crust, becomes first of a copper colour and then of a blueish black, and soon after inflames and burns with a most brilliant red light.

After this combustion, either the whole or a part of the fluoric acid, according as the quantity of potassium is great or small, is found to be destroyed or absorbed. A mass of a chocolate colour remains in the bottom of the retort; and a sublimate, in some parts chocolate, and in others yellow, is found round the sides, and at the top of the retort.

When the residual gas afforded by this operation is washed with water, and exposed to the action of an electrical spark mixed with oxygen gas, it detonates, and affords a diminution such as might be expected from hydrogen gas.

The proportional quantity of this elastic fluid differs a little in different operations. When the fluoric acid has not been artificially dried, it amounts to one-sixth or one-seventh of the volume of the acid gas used; but when the fluoric acid has been long exposed to calcined sulphate of soda, it seldom amounts to one-tenth.

I have endeavoured to collect large quantities of the chocolate coloured substance for minute examination; but some difficulties occurred.

When I used from eighteen to twenty grains of potassium, in a retort containing from twenty to thirty cubical inches of fluoric acid gas, the intensity of the heat was such, as to fuse the bottom of the retort, and destroy the results.

In a very thick plate glass retort, containing about nineteen cubical inches of gas, I once succeeded in making a decisive experiment on ten grains and a half of potassium, and I found that about fourteen cubical inches of fluoric acid disappeared, and about two and a quarter of hydrogen gas were evolved. The barometer stood at 30.3, and the thermometer at 61° Fahrenheit; the gas had not been artificially dried. In this experiment there was very little sublimate; but the whole of the bottom of the retort was covered with a brown crust, and near the point of contact with the bottom the substance was darker coloured, and approaching in its tint to black.

When

When the product was examined by a magnifier, it evidently appeared consisting of different kinds of matter; a blackish substance, a white, apparently saline substance, and a substance having different shades of brown and fawn colour.

The mass did not conduct electricity, and none of its parts could be separated, so as to be examined as to this property.

When a portion of it was thrown into water, it effervesced violently, and the gas evolved had some resemblance in smell to phosphuretted hydrogen, and was inflammable.

When a part of the mass was heated in contact with air, it burnt slowly, lost its brown colour, and became a white saline mass.

When heated in oxygen gas, in a retort of plate glass, it absorbed a portion of oxygen, but burnt with difficulty, and required to be heated nearly to redness; and the light given out was similar to that produced by the combustion of liver of sulphur.

The water which had acted upon a portion of it was examined; a number of chocolate-coloured particles floated in it. When the solid matter was separated by the filter, the fluid was found to contain fluete of potash, and potash. The solid residuum was heated in a small glass retort in oxygen gas; it burnt before it had attained a red heat, and became white. In this process, oxygen was absorbed, and acid matter produced. The remainder possessed the properties of the substance formed from fluoric acid gas holding siliceous earth in solution, by the action of water.

In experiments made upon the combustion of quantities of potassium equal to from six to eleven grains, the portion of matter separable from the water has amounted to a very small part of a grain only, and operating upon so minute a scale, I have not been able to gain fully decided evidence, that the inflammable part of it is the pure basis of the fluoric acid; but with respect to the decomposition of this body by potassium, and the existence of its basis at least combined with a smaller proportion of oxygen in the solid product generated, and the regeneration of the acid by the ignition of this product in oxygen gas, it is scarcely possible to entertain a doubt.

The decomposition of the fluoric acid by potassium, seems analogous to that of the acids of sulphur and phosphorus. In neither of these cases are the pure bases, or even the bases in their common form evolved; but new compounds result, and in one case sulphurets, and sulphites, and

in the other phosphurets, and phosphites of potash, are generated.

As silex was always obtained during the combustion of the chocolate-coloured substance obtained by lixiviation, it occurred to me that this matter might be a result of the operation, and that the chocolate substance might be a compound of the siliceous and fluoric bases in a low state of oxygenation, with potash; and this idea is favoured by some trials that I made to separate silex from the mass, by boiling it in concentrated fluoric acid; the substance did not seem to be much altered by this process, and still gave silex by combustion.

I endeavoured to decompose fluoric acid gas in a perfectly dry state, and which contained no siliceous earth; and for this purpose I made a mixture of one hundred grains of dry boracic acid, and two hundred grains of fluor spar, and placed them in the bottom of an iron tube, having a stop-cock and a tube of safety attached to it.

The tube was inserted horizontally in a forge, and twenty grains of potassium, in a proper iron tray, introduced into that part of it where the heat was only suffered to rise to dull redness. The bottom of the tube was heated to whiteness, and the acid acted upon by the heated potassium, as it was generated. After the process was finished, the result in the tray was examined.

It was in some parts black, and in others of a dark brown. It did not effervesce with water; and, when lixiviated, afforded a dark brown combustible mass, which did not conduct electricity, and which, when burnt in oxygen gas, afforded boracic and fluoric acid. It dissolved with violent effervescence in nitric acid; but did not inflame spontaneously in oxymuriatic acid gas.

I have not as yet examined any of the other properties of this substance; but I am inclined to consider it as a compound of the olive-coloured oxide of boracium, and an oxide of the fluoric basis.

In examining the dry fluoric acid gas, procured in a process similar to that which has been just described, it gave very evident marks of the presence of boracic acid.

As the chocolate-coloured substance is permanent in water, it occurred to me that it might possibly be producible from concentrated liquid fluoric acid at the negative surface in the Voltaic circuit.

I made the experiment with platina surfaces, from a battery of two hundred and fifty plates of six inches, on fluoric acid the densest that could be obtained by the distillation of
fluor

fluor spar and concentrated sulphuric acid of commerce, in vessels of lead. Oxygen and hydrogen were evolved, and a dark brown matter separated at the deoxidating surface; but the result of an operation conducted for many hours, merely enabled me to ascertain that it was combustible, and produced acid matter in combustion; but I cannot venture to draw the conclusion that this acid was fluoric acid, as it was not impossible that some sulphureous, or sulphuric acid might likewise exist in the solution.

I heated the olive-coloured inflammable substance, obtained from the boracic acid, in common fluoric acid gas in a plate glass retort; the temperature was raised till the glass began to fuse; but no change, indicating a decomposition, took place.

I heated six grains of potassium with four grains of powdered fluor spar in a green glass tube filled with hydrogen; there was a slight ignition, a minute quantity of hydrogen gas was evolved, and a dark gray mass was produced, which acted upon water with much effervescence, but left no solid inflammable residuum.

[To be continued.]

XVI. *Suggestion for establishing a Telegraphic Intercourse between London and Dublin.* By the Rev. Mr. JAMES HALL.

To Mr. Tilloch.

SIR, **A**s it is the duty of every good subject to contribute what he can to the service of his country, I have ventured to trouble you with the following hints on the subject of telegraphs.

Previous to my setting out for Ireland, (through the greater part of which I travelled lately,) I began to study the physical geography of that country. On turning my attention to this matter, and conversing with Dr. Thomson of Kensington Gravel Pits, and others, on the subject, the Doctor drew my attention to the circumstance, that the old maps of Ireland, particularly those of the fifteenth century, and about the time of the Spanish armada, laid down the northern parts of that kingdom much nearer the Mull of Cantire, in Scotland, than the modern maps in general do. The question then was, Whether the maps of Ireland of the fifteenth, or those of the present century, are the more correct? On arriving at Torr Point, Fair Head, the nearest point of Ireland to Scotland, I hired a boat and sailed to Cantire.

Cantire. But, instead of finding the distance from 20 to 30 miles, as laid down in some of our modern maps, I found it only eleven miles and a half.

Having ascertained this fact, it occurred to me, that, although no telegraphic communication can take place between Dublin and Holyhead, in Wales, which is 63 miles; nor between Drogheda in Ireland, and Port Patrick in Scotland, which is 25 miles; yet that information might be *easily* communicated from Fair Head land, to the Mall of Cantire, by a telegraph. One thing is certain, that it is nearly as far between the points of communication, by telegraph, at Putney, and the one next to it, on the line from London to Portsmouth, as between Torr Point, Fair Head, Ireland, and the nearest point of land in Scotland; and that at one place, on the same line of communication, the nearest communicating points, by the telegraph, are nearly *thirteen* miles distant.

In erecting a telegraph southward from Dublin to Cork, and northward to Fair Head, there seems no difficulty at all. At Fair Head, and the opposite point in Scotland, signals to draw attention might be addressed both to the eye and the ear; those to the ear being calculated to rouse attention, and induce people to look out and apply to their glasses. From Cantire, through the Isles of Arran, Butc, and other places, information might be sent by Glasgow, Edinburgh, &c. &c., direct to London, and back again to Dublin, Cork, &c. &c., in the course of a few minutes.

Speedy information to and from our fleets in the harbour of Cork, &c., in Ireland, as well as to and from those at Portsmouth, Plymouth, &c. &c., in England, is certainly an object of great importance; and, in my humble opinion, the only way to have little or no use for soldiers, sailors, ships of war, batteries, cannons, telegraphs, &c., is to have plenty of them in readiness.

I remain, sir, yours truly,

St. Martin's Lane,
August 15, 1809.

JAMES HALL.

XVII. *A concise Abstract of Professor MITCHILL'S Discourses on Mineralogy, the sixth great Section of the Course of Natural History which he delivers in the new Institution at New York.*

ALMOST immediately on his return home, after the termination of the congressional session on the third of March 1809,

1809, Dr. Mitchill commenced his academical duties as one of the professors of the new Institution at New York. Although he arranged the subject allotted to him under the heads of *geology, photology, pyrology, hydrology, ærology, mineralogy, botany, zoology, and uranology*, it is not the intention of the writer of the present sketch to do any thing more than trace an outline of his mineralogy, and state the new views the professor has taken of this department of science.

He defined mineralogy to be the classification and detailed history of the materials which constitute the solid body of the earth. He explained the fourfold arrangement formerly made by *Bergman*, and followed by *Cronstedt, Werner, Kirwan, and Jameson*, distributing these great masses of material into four classes, 1. EARTHS, 2. METALS, 3. SALTS, and 4. INFLAMMABLES. Herein the method differed from the one given in his *Geology*, which, pursuant to the plan of *Werner*, had divided these same natural bodies into five sections: 1. the *primæval*, 2. *transition*, 3. *ternary*, 4. *alluvial*, and 5. *volcanic* rocks, stones, and earths. He then gave the history of lime, clay, barytes, flint, magnesia, strontian, elucidated by specimens; with notices of the minor earths. Next followed the account of platina, gold, silver, mercury, copper, lead, iron, zinc, and the inferior metals; the history of potass, soda, and ammoniac; their production, preparation, and manufacture, with their chemical and œconomical uses. Salts distributed into orders, as 1. alkaline; 2. acid; 3. neutral; 4. middle; and 5. metallic. Inflammable bodies considered: sulphur, coal, bitumen, amber, petroleum, naphtha, pyrites, and the other analogous articles.

On reviewing this whole class of bodies, professor Mitchill declared himself dissatisfied with the arrangement of *Bergman* and his followers. He therefore, with much hesitation and diffidence, proposed another disposition of things terrestrial thus:

I.—Bodies possessing a strong attraction for phlogiston (or hydrogen) and oxygen.

These are, 1. The *alkaline* metals, potass, soda, and ammoniac. 2. The “ascertained” *earthy* metals, magnesia, barytes, strontian, and lime; and the “probable” *earthy* metals, flint, clay, zircon, and glucine. 3. The *calciform* metals, platina, gold, silver, copper, iron, mercury, lead, tin, cobalt, zinc, nickel, chrome, titanium, columbium, molybdæna, arsenic, manganese, wolfram, uranium, tellurium, and the other articles of this form, whatever they were.

were. 4. *Gaseous* metal, azote. These, which constitute the principal part of terrestrial beings, Dr. Mitchill considered under four memorable points of view. First, in connection with sulphur, forming *ores*; secondly, with oxygen, making *oxides* and *acids*; thirdly, with phlogiston, or hydrogen, constituting what are properly denominated *metals*; and fourthly, combinations with each other, composing glass, porcelain, earthenware, the other prodigious mass of *alloys* and *amalgams*, or *metallic* mixtures.

II.—Bodies abounding in inflammable and phlogistic matter.

Under this section are placed as well the sulphuric, phosphoric, and carbonic, as the hydrogenous compounds. Accordingly sulphur, inflammable air, coal of many kinds, all the metals in their reduced, malleable, and ductile states, phosphoric and bituminous materials of every denomination, and generally those substances that burn with flame, belong to this section.

III.—Bodies abounding in oxygen.

The substances remarkable for affording oxygen are the phosxygen of the atmosphere, acids of every sort, especially those which readily undergo decomposition, water, and all the metals in oxidized and acid state.

He said, by way of explanation, that the modern celebrated experiment for decomposing potash by means of iron in a red-hot gun-barrel, was nothing more than a case of double elective attraction. A phlogisture of iron and an oxide of potassium were brought within the sphere of each other's action, in a convenient heat; in which the oxygen quitted the potassium to unite with the iron, while the phlogiston, which had deserted the iron, associated itself with the potassium, and thereby a phlogisture of potassium and an oxide of iron were formed. He believed such action of the metals upon each other was very common, and thought the true theory of the operation of metallic plates in the Galvanic pile would be ultimately explicable upon this principle.

Professor Mitchill explained, upon the principle of this classification, the great and the small chemical changes which natural objects undergo, both in the workshops of the artists and in the laboratory of Nature. The constitution of the numerous and extensive order of metals was defined, in their state of oxide and acid, consisting of metal and oxygen, and in their ductile and resplendent forms, composed of metal and phlogiston. And some metals, he

said,

said, were capable of existing in an intermediate condition, having lost their phlogiston without having acquired oxygen, such as massicot seemed to be among the preparations of lead, finery cinder among the productions of iron, and certain of the white sublimate among the modifications of zinc. He illustrated this idea by observing that carbon was an example of these several combinations; for when united with phlogiston it is inflammable, or burns with blaze; when associated with oxygen it is incombustible; and when connected with neither of them, it would indeed consume by a red heat, through the connection it formed with oxygen; but, inasmuch as no phlogiston is present, there is no appearance of flame.

He expressed the probability of the metallic nature of carbon, phosphorus, and sulphur; all of which when combined with metals might be considered as alloys, in the same manner that the articles of the first order are when mixed with each other. By reason of the different attractions which the metallic bases exert for oxygen and for phlogiston, at different degrees between the highest and lowest temperatures, they are oxidized or metallized; and those processes in the more refractory, are aided by the chemical action of the more fusible metals, and of inflammables, cooperating with the requisite heat. And as both oxygen and phlogiston exist plentifully in the fire, the metallic basis, according to its constitution, combines either with one or the other, and thereby becomes either a *phlogisture* or an *oxide*; or it remains unconnected with either in the middle state, in which some of the metals have been observed.

In the course of his observations, professor Mitchill gave an account of the experiments made, in the Royal Institution of London, on the earths and alkalies, and of the disposition of the *inflammable* agent to attach itself to the *negative* side of the Voltaic apparatus, while the *oxygenous* adhered to the *positive*. And finally, Dr. Mitchill, by an independent and different survey of this interesting subject, has arrived at a conclusion substantially the same with that of professor Davy.

XVIII. *Account of the internal Exhibition of the Acetate of Lead in several Diseases. Communicated by THOMAS EWELL, M.D., of Washington, to Dr. MILLER*.*

LAST August I was requested to visit a cartman, John Steins, addicted to drunkenness, and living near the navy yard, in an unhealthy situation. In the night he had been seized with fever, which was followed by a profuse discharge of blood from his stomach and anus; his wife said he had lost more than two gallons; and I found him with no pulse, looking exactly as a man dying, from loss of blood.

His alarming situation called for some powerful stimulus; but it occurred to me that his liver had been affected, which preventing the passage of blood through the vena portæ, was followed by that engorgement of the viscera, which had caused the rupture of the blood-vessels of his bowels; and consequently that a stimulus would only serve to increase the power of the vessels to discharge the remaining blood. I immediately determined to give him the sugar of lead. On adverting to the urgency of the case, as well as the state of his stomach, which had been accustomed to the most powerful incitants, I directed him to take seven grains of the medicine every two hours, until the discharge of blood ceased. On swallowing the second dose, he exclaimed, "Great God, at length my guts are healed!" The discharge soon lessened, and no doubt the hæmorrhage stopped; but as a little blood (which had not been evacuated from the bowels) continued to come off, he took thirty-five grains in less than twelve hours. By degrees I gave him stimuli, and never did a man recover more rapidly: and this I considered as affording a new proof of the efficacy of free bleeding in curing fevers quickly. However, the man never could get over that particular pallid countenance, peculiar to those bled too copiously.

Shortly after the cure of Steins, I was called to David Mead, a drummer of the marine corps. He too was a drunkard, was fat, and indolent. He had a high fever, for which he was ordered bleeding, and a dose of calomel. In the night he was taken with a purging of blood, and I, without seeing him, directed injections of cold water. In the morning I found him almost dead; and the assistant surgeon, Doctor Harrison, pronounced "he was about to die." I ordered him to take five grains of sugar of lead every two hours: the bleeding ceased after the third, yet he took a

* From Drs. Mitchill and Miller's Medical Repository, vol. v.

fourth dose. His pulse began to rise in the evening, and next day I ordered him the bark: by the use of porter he soon recovered strength, though he continues very pale. He certainly lost a great deal of blood, but I cannot state the precise quantity.

On mentioning these cases to the Hon. Doctor Bibb, of the House of Representatives, from Georgia—he stated that with equal success he had given the sugar of lead to a young lady, who, during a paroxysm of fever, had an intestinal hæmorrhage. The doses, however, which he prescribed did not exceed two grains; and the salvation of the life of his patient as certainly depended on the sugar of lead, as in the cases I have related.

My prejudice respecting the poisonous qualities of lead being by these cases removed, I readily gave it a trial in other instances. In uterine hæmorrhage I found it of essential service, like all who used it before me.

Mrs. A. the wife of the D— M—, of the marine corps, aged about forty-five years, had a constant discharge of blood from her vagina, for four months; within a few days it became so profuse as to endanger her life; when called to her, I directed the exhibition of three grains of sugar of lead every two hours. The third dose relieved, and since I have heard of no further complaints. In cases of diarrhœa, I have met with the same success, from the use of lead, which Dr. Archer has stated in a former number of the Repository. But the cases in which I used it were attended with high inflammation; and one of my fellow practitioners told me, that the medicine uniformly failed, when the system was in a low state. Within the last month I have used it in the following case:

John Russel, a boy aged thirteen years, belonging to lieut. Harriden, of the navy, drank at once, one pint and three gills of strong apple brandy. In a short time he had no pulse, quick respiration, and all around him thought he was dying. About five hours after the spirit was drunk, I was called to him. Such was his irritable state, that nothing which was introduced into his throat could excite vomiting. I had to rely only on external remedies, and these I applied in full force. It was only by severe general whippings, rubbing with mustard and vinegar, and finally by blisters caused by the blaze of fire, that I could excite any action in his system. In fifteen hours I had to resort to injections of ether, brandy, laudanum, and such stimulants, to keep him from sinking. These were discontinued by degrees, until the end of the third day. On the fourth day he had

had most excruciating pain in his abdomen, and serous discharges from his bowels—His pulse became highly inflammatory. Injections, purges, and prepared chalk did not relieve. In this situation I ordered him to take two grains of the lead every two hours. The third dose seemed to remove entirely the inflammation: so that in two days the boy had no other complaint but his blisters, which soon healing, he was discharged for duty. From this I conclude, that the lead is worthy of a trial in dysentery, at least after the evacnants are used.

When I found the throat and œsophagus of Russel so irritable, I unsuccessfully endeavoured to procure a probang and flexible tube, to introduce into his stomach. With the first I could have extracted some of the brandy in his stomach, and with the last probably the whole: so that the danger, from that alcohol, which had not acted, would have been removed. In all cases where poisons, such as spirits, opium, &c., are swallowed, and are followed by extreme irritability of the throat, I have no hesitation in saying, that great relief might be afforded by introducing the end of some flexible tube into the stomach. By this tube much vapour would escape; the body could be so placed as to favour the running off of any fluid, or, at least, it would be practicable to evacuate considerably by suction: by dilution with water, and repeated evacuations, the stomach might be entirely cleansed. Indeed, my reflections on this subject have impressed me with the belief, that the introduction of such a tube into the stomach, for the evacuation of poisons, and into the rectum, up to the sigmoid flexion of the colon, for the escape of that flatus, causing colic, will prove of as much service to mankind as the catheter has been in the discharge of urine from the bladder. At least the practice I propose in such cases is far more reasonable than washing the stomach for some disorders, by means of an instrument, which, I observe, Heister says, was done by the elder surgeons.

The last cases which embarrassed me, and in which I administered the sugar of lead, were those of salivation. In the navy hospital under my care, I find frequent occasion for the use of mercury: in many instances the salivation has been excessive, and no mitigation of symptoms could be effected by opium, sulphur, blisters, purgatives, or any medicine that has been recommended. I have seen death arise in one instance from the salivation, and have apprehended it in many.

This was leading me to lessen the frequency of mercury

in my prescriptions, until I found a remedy in the acetate of lead. Two cases occurred in the hospital at the same time, in which the salivation was alarming in degree as well as duration.

It had occurred to me that the *saccharum saturni* cured hæmorrhages and inflammations, by exciting the *action of contraction* in the vessels. Now, as mercury produces a contrary effect, (for it really enlarges the vessels, as shown by the glands of the throat, &c.) it appeared to me that nature intended the action of one as much to counteract the action of the other in animals, as she did an acid to counteract an alkali: but be the theory correct or not, I administered the lead in doses of two grains, four times a day. On the second day one of the poor men asked me for more of the medicine he took the day before. I gave it on the second day, and it was discontinued on the third, for they were both cured of the salivation. To this, I will add, that they washed their mouths with lead-water; and that the first time I ever found a bad symptom produced by the lead was in one of these cases. Violent belly-ache came on: this soon went off: and although the symptom may oftener occur with others than it has with me, I conceive it to be no objection to its use; for, but few would prefer a month's salivation to a pain in the abdomen for a few hours.

You have now the whole account of my use of the sugar of lead. I hope others of your correspondents will experience and communicate an account of its virtues. When fair trials are made of it, I feel confident that there will be no singularity in the high opinion entertained of it as an internal medicine.

XIX. *On the Use of Fumigations in Army Hospitals:*
In a Letter from M. CHAMSERU, to M. GUYTON.*

Posen, August 18, 1807.

I AM glad to observe that every thing which concerns the success of the anti-contagious process, for which we are indebted to you, excites your solicitude, and I have now the honour to communicate some direct observations on this subject.

It is sometimes difficult to prevail on mankind to adopt improvements which have for their object the preservation of their health. I was more fortunate in this respect, however, in our army hospitals in Poland than in Austria.

* From *Annales de Chimie*, tome lxiiv. p. 172.

I consider low and remittent fevers produced by the miasmata of an hospital as obstinate epidemics, which with slight attention may be avoided. They originate from negligence or from the hospital being over-crowded, evils which a becoming firmness on the part of the medical officers will of course prevent.

During eight months that I performed the duties of the great hospital at Posen, containing 400 beds, and subject to great variations and changes with respect to the number of the patients, no infection made its appearance in any perceptible manner: no person attached to the service contracted it; and several young medical attendants, who had been attacked with the contagion of other establishments, were brought to the above hospital for the benefit of our superior salubrity, and were restored to health.

M. Desgenettes, the physician general to the army, gave me the following instructions: "I request that when the hospitals are crowded, or when low fevers prevail, you may use the fumigations with the hyper-oxygenated muriatic acid gas, according to M. Morveau's process. This valuable prophylactic has been very improperly rejected, and has been thought useful only when contagious diseases were completely developed. I request you to inform me if this purifying remedy is put in practice."

In consequence of this letter I constantly recommended these fumigations in the wards of the hospitals to which I was attached. The instructions for health, inserted in the last Pharmaceutical Formula, for the use of military hospitals, seem to make this measure subordinate to the removal of the patients from the infected place, and successively changing their beds from room to room. Circumstances, however, may occur to prevent these measures from being adopted, and it is important to simplify the operation as much as possible. Without occasioning, therefore, any removal of the patients, the hyper-oxygenated muriatic acid gas may be used morning and evening without inconvenience. An attendant may carry backward and forward an earthen vessel containing some muriate of soda and manganese and cold sulphuric acid, taking care to stir it frequently with a spatula.

Neither the attendants nor patients have ever suffered any bad effects, in my presence, from the pungency of the fumigation. Some windows, however, may be opened to give vent to the fumigation, but if the weather be cold this may be dispensed with; and the influence of the fumigation partly

partly depends upon its being some time confined within a close place.

However great may be the energy of the disinfecting process, I do not think that too much ought to be expected from it. A serious accident happened a month ago in an hospital where perfect salubrity had previously reigned. A church, which had been converted into a fine ward with 60 beds for chronic diseases, was infected with a fecal smell, which exhaled from the soil on account of a vast burying vault having been overflowed by the bursting into it of a cesspool. The sick and wounded were instantly removed: the vault was cleaned and fumigated as well as possible, and the fumigations were repeatedly made in the church itself with closed doors. In four or five days it was necessary to fill it again with patients, and the fumigations were continued for a week: no contagion was perceived.

In my opinion, the instructions in the Formula above alluded to are not sufficiently explanatory with respect to the preservative effect of hyper-oxygenated muriatic acid gas. I think it has also the property of killing vermin; and it ought to be applied to the clothes of the sick soldiers which are laid up on their coming into the hospital. Besides flies, which annoyed us much in Poland, we were also dreadfully afflicted with fleas and bugs, and on applying the above fumigations they were all found dead.

Letter from M. BENOIT MOJON, Chief Physician to the Military Hospital at Genoa, on the same Subject.

Genoa, August 20, 1807.

Two months ago a contagious dysentery made its appearance in the military hospital at Genoa, and almost all the patients under my care, amounting to about 200, were attacked. As it is generally allowed that when dysentery is contagious it is owing to an indiscriminate use of the same privy, I was anxious to try if fumigations of oxygenated muriatic acid had the effect of destroying the contagious exhalations which produce dysentery in healthy as well as in diseased subjects. With this view I fumigated the privies in the hospital twice a day, and succeeded in destroying this contagion in a few days. Contagious dysentery being of frequent recurrence in the hospitals of Genoa, it is likely that I shall have more frequent opportunities of witnessing the happy effects of similar precautions.

Note

Note by M. GUYTON, subjoined to the two preceding Communications.

WHEN it occurred to me to transmit these letters to the *Annales de Chimie*, I asked myself if there were not abundance of observations already published on the efficacy of these fumigations. I hope to be excused, however, when I inform the public that, in works professedly intended for supporting the practice, even in the *Bibliothèque Medicale*, some young physicians have inserted articles tending to weaken the public confidence in these operations, and to suspend their execution, notwithstanding the instructions of the councils of health and the orders of government. The old routine of perfumes has been recommended; and fears have been started respecting the action of the oxygenated muriatic acid, by ascribing the same disinfecting virtue to fixed substances, which act upon those only in immediate contact.

Is it not astonishing, for instance, to see it inserted in the German Journal of Hufeland, without any critical remark, that the contagious miasmata of the plague and of typhus are chiefly attached to metals, that they are rather acid than alkaline, that lime and the alkalis are useful for preserving from any contagion? "*Without, however, pretending to dispense with the fumigations of Guyton Morveau, and Smith, equally efficacious, as is proved by experience; but more difficult in their application, and more dangerous to respiration.*"

The author of this extract, in Nos. 47 and 49 of the same miscellany, carries still further his vague doubts and unwarrantable conclusions. He finds fumigations of sulphuric acid sanctioned by Homer, because mention is made in the *Odyssey* of the purification of a house by the combustion of sulphur: he calls by the name of nitro-sulphuric fumigations, those made by the powder of the physicians of Moscow, in which there are only *eight* parts by weight of nitre, and *six* of sulphur to *twenty-six* of raspings of guaiacum, with the leaves and berries of juniper and myrrh: he supposes that we may purify inhabited rooms by burning sulphur in them: he even gives reason to think that the efficaciousness of the powder of the Moscovite physicians was proved on *seven criminals condemned to death, who were infected with the plague and recovered*; whereas, as I have reported according to Dr. A. Wolff, it was only some *infected pellises that were exposed to a strong fumigation of sulphur and saltpetre combined*, and none of the criminals

obliged to put them on *took the plague*; and in his *Considerations sur l'Histoire de la Peste de Wolhinie*, in 1798, Dr. Hufeland points out the use of this powder in the disinfecting of clothes only*. If the author of these articles really thought that men might be with impunity exposed to sulphurous fumigations, Why did he not quote the authority of Propertius, who tells us that in order to purify him Cynthia burned sulphur thrice upon his head †? It is nevertheless on the subject of these same sulphurous fumigations produced with the mixture of resinous woods, nitre and sulphur, that he declares, “*The physicians of Moscow may fairly dispute the honour of this discovery with Messrs. Guyton Morveau, and Smith.*” Soon afterwards he informs us that the use of fumigations is lost in the remotest antiquity, the Hebrew, Arab, and Latin writers mention it as well as the Greeks.

Of what importance is the name of the inventor, and the date of his discovery, provided the truth of it be established, and humanity is benefited? But when we read in the same page,—*that the alkalis, lime, and the other absorbent earths have also something preservative in them—that Hippocrates preserved Greece from a plague brought from Ethiopia, by kindling fires in which various aromatic substances were burnt—it is certain that not only frankincense and myrrh, but the other resinous gums also, and particularly camphor, the aromatic essences, juniper, and an infinity of odoriferous vegetables employed in perfume, or as vapours, have manifested very salubrious effects,*—have we not a right to demand, What respect is due to the opinion of those who are not capable of distinguishing substances which, by their spontaneous expansion, can attack deleterious miasmata in the air, from substances which do not alter what comes in contact with them: and those which *burn* by their chemical action, contagious viruses from those which cannot disguise their smell a single moment? Is there not reason to fear, that, determined by the facility of procuring some odoriferous plants, they prefer perfumes, the inefficacy of which is now ascertained and publicly declared in every book on epidemics ‡? In this way opinions thrown out for the sake
of

* Bib. Méd. tome xvi. p. 405.

† *Terque meum tetigit sulphuris igne caput.* Lib. iv. Eleg. viii. v. 86.

‡ On this head we may consult the report of the commission of the Academy of Sciences on Prisons in 1780; the opinions of Vicq d'Azyr, Montigny, &c., on epidemics and epizooties; the instructions of the Council of Health, 7 Ventose, an. ii.; the report of the committee of the Institute, 11 Fructidor an. xi.; that of the committee of the School of Medicine of Montpellier, sent to Andalusia in 1800; the *Code Pharmaceutique*, for the use of hospitals,

of displaying a little erudition frequently retard the propagation of the most important facts.

XX. *An Inquiry into the Terrestrial Phænomena produced by the Action of the Ocean.* By JOHN CARR, Esq., of Manchester.—No. II.

To Mr. Tilloch.

SIR, **T**HE several facts and reasoning in my two last papers have been chiefly directed to show, that the exterior of our earth has been moulded into all its infinite variety of inequality by the sole action of moving water; and I am now to inquire into those internal characters which are more immediately the object of geological research, and which have doubtless been effected by the same plastic and potent agency.

The two most inexplicable phænomena in geology, and which, beyond all others, have tempted the inquirer to wander out of the limits of natural operation into hypothetical regions of invention and surmise, are the various inclinations of the strata from horizontal up to vertical, and the elevation of the ocean up to those astonishing heights on our mountains, which bear the most unequivocal testimony of its former action. To get over the latter and greater difficulty, Dr. Hutton, whose extensive personal researches and discriminating powers merit the highest eulogy, has lighted up internal fires in the lowest regions of the earth, whose expansive forces have elevated our continents from the lowest beds of the sea up to their present heights, and, of course, thrown the seas which covered them over the existing continents which had become impoverished and worn out, and which are to undergo a due season of renovated pickling in the briny deep, when the instinctive fires are to withdraw their support from us, shifting their buoyant powers to the submerged lands; and these, kicking the beam, are to deluge our worn-out hills and valleys with the grand restorative specific-dilute muriate of soda. A glance at the map will show how strangely capricious are the operations of these internal ignitions, forcing up in some cases continents extending from pole to pole; and in other instances, in the

hospitals, by M. Parmentier; the circular letters of the minister of the interior to the prefects, of 30 Nivose and 15 Messidor, an. xiii.; the reports made by M. Desgenettes, inspector-general of the military hospitals; of professor Pinal; the programmes of the medical jury under the superintendance of M. Chaussier, &c. &c.

midst

midst of vast seas, popping up the bald point of a peaked rock, with scarcely surface enough of hatching room for one of mother Carey's chickens.

Mr. Kirwan, whose various chemical and mineralogical researches have added so extensively to the acquirement and spread of natural science, reprobating these internal fires, as chronologically heathenish and pagan, has let in upon them an orthodox ocean, which has chained off our present seas to fourteen thousand feet below their former depth, leaving countless myriads of bivalved, univalved, and other marine animals, gaping in helpless anguish for their briny beverage, on the summits of our highest mountains. Whether there is more of ingenuity in providing or in filling up such enormous cavernous excavations in the profound bosom of our consolidated globe, I shall not stop to inquire.

To account for the great elevation and other anomalous irregularities in the strata, Mr. Farey, whose indefatigable personal researches have already added, and are yet likely to add, so much to our practical acquisitions, has announced his intention of employing an extinct erratic satellite, whose near approach to our globe is to reverse the direction of gravity, and excite by its attractive force rebellious movements in the upper strata, heaving them up in successive and doubtful movements, whither to continue attached to their parent planet, or, yielding to the usual and dangerous seductions of novelty, to fly off to the evanescent stranger. Nay, it should even seem that some of the undutiful progeny have actually made this most singular elopement, and that the denudated tops of our eminences exhibit naked proofs of these paternal derelictions. As, however, the vertical strata and other anomalies which this lunation lever is made to heave up are disseminated in local patches all over the earth, the movements of the heavenly visitant, unlike the even and equable progression of all its aerial prototypes, must have been strangely vagarious, and made in every latitudinary direction, by occasional dips and irregular snatches, like the plunderous dash of a hungry hawk at a flight of passing pigeons.

It is in itself farcical to apply any serious argument to such hypothetical reveries as these; and this consideration, I trust, will apologize for departing altogether from the decorous gravity of philosophical disquisition.

As far as we have yet made any successful discoveries into the operations of Nature, we find them all the result of permanent laws, which, acting with provident wisdom and rotative perpetuity, give a precision, a stability, and a duration,

ration, to every natural system, wherein no human calculation can trace out either a beginning or an end. Chance, mischievous irregularity, or accidental violence of action, have no place in the execution of these undeviating laws; they are only the blind applications of our blind and partial views of things.

The prolonged preservation of the ephemeral species, whose buzzing progeny commence and terminate their existence on the same day, is, as far as we can see and judge, as effectually provided for and secured, as that of the solar system.

And shall we look upon the stupendous and massive effects which the exterior and interior survey of our globe every where displays; and search for their causes amongst temporary and extinct agents? Shall so mighty an occurrence, in the scheme of terrestrial existence, as the stratified conformation and transition arrangements of the vast materials of our earth, have no permanently established laws for their regulation and governance, while the fluttering insect of an hour is provided with its peculiar rules of formation and perpetual duration? It was the impressive conviction that all geological phænomena have resulted from systematic and permanently operating laws, which are now in full activity, and the reprobation of all fortuitous hypothesis in their investigation, that first induced me to offer my sentiments on a subject which had previously occupied my attention only in common with other branches of natural history: and I will now proceed with the sketch of that outline, which I offer with the utmost diffidence, as a remote approximation towards a theory of the geology of our earth.

The submersion of our present continents for an indefinite duration, and the formation of all their strata by marine action, are no longer questions in modern science; but it is yet an unascertained, and perhaps the most important of all geological queries:—Whether the present conformation of the interior of our earth has been derived from one, or from many successive immersions of the same country? and until a specific and decisive answer can be given to this most interesting interrogatory, the multifarious phænomena of geological discovery will continue to be, as they have hitherto been, the prey and the sport of ingenious sophism and delusive hypothesis.

There are, I conceive, several distinct circumstances, which will authorise a probable decision on this most important question of singular or plural immersion. All stratified rock, not evidently the produce of marine shells

in their native beds, has been formed from the consolidation of strata previously derived from aqueous deposition. The Vulcanists triumphantly assign the consolidation, and in many cases maintain the actual fusion of the strata, to internal fires, alleging that a mere hardening by evaporation of the moisture, in the stony matter, would necessarily leave the rock in a state of porosity, which observation everywhere contradicts. The truth however is, that the assumption of internal fires is as superfluous as it is visionary, and the desiccation of solidifiable strata, under an incalculable pressure of the superincumbent strata, aided by the agglutination of stony matter in solution, during a period of indefinite extent, is amply sufficient to account for the highly indurated and dense state in which we now find all stratified rock.

The absolute completion of the solidifying process seems however to require an emersion above the level of the ocean; for it is difficult to imagine how many of the species of rock with which we are acquainted, could have been both precipitated and consolidated under one and the same immersion. If there is any truth in this observation, it would decide the question of more than one submersion; for there are numerous instances of rock which bear conclusive evidence of the attrition of marine action after their induration. The rock of Table Mountain at the Cape of Good Hope may be given as one of these instances. It is repugnant to all rational belief, to admit that the materials of that vast rock experienced an aqueous deposition, a subsequent consolidation, and a final destructive denudation to its present state, all under one and the same immersion.

The numerous breaks and separations which traverse the strata, designated faults, throws, heaves, troubles, and other names expressive of their effects in mining, are also, I think, evidence of distinct immersions. Their frequent rectilinear direction, and their worn and abraded angular asperities, fully prove that they were formed after the consolidation of the strata in which they occur, and also, I conceive, establish them to have been originally chasms, gullies, ravines, valleys, channels, and other land excavations, clefts and fissures, and to have been filled up in a subsequent immersion.

Mineral veins in extensive fissures which traverse stratified rock, can, I imagine, only be referred to the same origin, and therefore testify the same result. The minerals have assuredly obtained their present situation in an immersion entirely distinct from that in which the strata were formed.

The

The monstrous opinion that all minerals and their beds have been forced up from below, and in their ascent have produced the enormous dispartations of rock wherein we now find them, is rapidly declining; and the rational and far more natural conclusion, that all minerals and their heterogeneous matrices have arrived at their situations by a descending process, is daily establishing itself; and it can be maintained on no other reasoning than that the separations in the strata were originally land fissures, clefts, rocky valleys, and other excavations, such as all countries now more or less abound with; and that they were filled up with diversified materials in a subsequent immersion. In fact, numbers of these fissures bear palpable indication of a stratified form in their contents; and those sparry and other incrustations which are so usually found adhering, in many distinct layers over each other, to the rocky sides of mines, and which have been deemed certain proofs of actual fusion, are, on the contrary, the most decisive evidence of an aqueous process down the perpendicular side of the rock, the distinct layers of different materials concreting and passing over each other in regular succession.

Perhaps the most irrefragable proofs of the distinct immersions of the same country are to be found in those singular instances, sufficiently frequent, of the formation of secondary horizontal strata over vertical strata of primary granite and schistus.

This rectangular formation of strata contains in itself a physical impossibility, as to its being the produce of a single immersion.

Other proofs of separate submersions of the same country are to be found in the extensive beds of sand and pebbles, whose present situation can only be referred to former shores of the ocean. All granular sand and loose stone are derived from the detritus of rock, the desiccated strata of former marine deposition; and all pebbles have acquired their smooth and rounded forms from the attrition of agitated water in the streams of rivers or on the shores of the sea. Immense beds of such sand and pebbles are found in every varying situation, from the tops of the highest mountains to the bottoms of the lowest valleys, either in loose masses, or in vast formations of pudding-stone and breccias, which are merely the indurated beds of sand and intermixed pebbles. Now if we trace these numerous and extensive beds from the first marine precipitation of the materials, through the subsequent desiccation of the strata, the after disintegration

disintegration of the rock, the period of aqueous attrition and rounding of the pebbles, their subsequent consolidation into breccia, and the after disintegration from pudding-stone again into sand and gravel, as occurs in thousands of instances, it will, I think, compel an acknowledgment that this wonderful history of material transformation includes a duration of time, in which we can perceive no commencement, and a distinct diversity of marine submersions of the same country.

Indeed, to pursue this most astonishing transition of matter from one state to another, without even approximating the limits of rational probability, it may be truly asserted, that there is not a cubic foot of material in any natural bed within the range of human inspection, that is not strictly derivative, having obtained its present form from its destructive dissolution in a former state; and that all our present continents have been constructed from the numberless remnants and fragments of other more ancient countries, evincing altogether periods of duration, systems of transition, and alternations of land and ocean, to which we can assign neither commencement nor termination.

What has been said, and much more that might be offered, afford, I think, as much of probable evidence as the nature of the case might be expected to furnish, that the different portions of our globe have been subjected to an indefinite number of marine immersions, and that it is in the infinite diversity of alterative effects which such alternating changes of land and sea would operate on local portions of the earth, that we are to look for the only natural illustration of the principal phænomena of geology. Strictly guiding our researches by the laws which we now find in action, we shall discover in Nature neither infancy nor old age, and the operations of the past and of the future will be found to human scrutiny equally illimitable. Every waste will have its compensation, and every decomposition its reconsolidation, and an endless succession of decay and reproduction will be found revolving through the whole in circular perpetuity.

The geologist who enters on his pursuit without these enlarged views, will be measuring the pyramid by the fragment of its apex. Every rock will be an obstacle, and every chasm a barrier to his progress; and calling hypothetical invention to his aid, he will fancy he is advancing, when, like the dog in the wheel, he is only scrambling against a bank.

I have, Mr. Editor, a great deal more to say on the diversified

versified inclinations of the strata, and on the probable cause which effects the alternating changes of land and sea; but having already trespassed so far on the periodical bounds of your limited and select publication, I shall decline troubling you further with my crude remarks. Their object has been not to offer new facts, but new views of the subject; and to point out, however imperfectly, the most probable channel through which we are likely to arrive at any rational theory of the diversified conformation of our globe.

I am, sir, your obedient humble servant,

JOHN CARR.

Princess Street, Manchester,
August, 1809.

XXI. *Proceedings of Learned Societies.*

FRENCH NATIONAL INSTITUTE.

Analysis of the Labours of the Class of Mathematical and Physical Sciences of the French Institute, for the Year 1807.

[Concluded from p. 76.]

M. BOUVARD has made a most useful addition to astronomy by his tables of Jupiter and Saturn. It will be recollected that the inequalities of these two planets have long perplexed astronomers, and would have still continued to do so, if the analysis of M. La Place had not discovered equations of a long period, which, by being confounded with the mean motions, had apparently accelerated the motion of Jupiter, and proportionally retarded that of Saturn. By the help of this theory, compared with the best observations made for more than one hundred years, M. Delambre succeeded in reducing to half a minute, under the most unfavourable circumstances, the errors of the tables, which formerly were from 15 to 20 times greater for Jupiter, and more than 40 times for Saturn. The errors would have been still less if modern observations were more numerous, and admitted of our rejecting every thing that preceded 1745: but the author had disposed his work in such a way as to be able to resume it, either of himself, or by means of another astronomer, as soon as some good observations were at hand. There remained besides a trifling inaccuracy respecting the mass of Saturn, and consequently the inequalities of Jupiter—M. La Place has revised and perfected his theory—M. Bouvard has been able to acquire a clearer idea of the doubtful mass;—and from all these changes, partly owing to good observations made since the printing of the first tables in 1789,

more

more exact tables have been obtained for the two planets; so that the greatest error does not at present exceed 13 degrees, and it even rises to this quantity on one occasion only, partly owing no doubt to an error in the observation. The utility of this labour has been extended to the ecliptic tables of the satellites of Jupiter, entirely recomposed by M. Delambre, and which will soon be published.

ZOOLOGY.—Of all the phenomena peculiar to certain animals, there are few so singular and so apparently contrary to the laws of animal œconomy as the lethargic sleep to which several viviparous quadrupeds are subject during winter. The lethargy of reptiles and of insects during the same season astonishes us much less, because we are less disposed to compare these beings with ourselves; and because in this state they lose a smaller number of their habitual properties.

In the lethargic mammiferæ, not only does an absolute state of rest take place, a complete abstinence and an insensibility to such a degree that we may sometimes burn or tear them in pieces without their perceiving it, but their respiration and circulation also gradually diminish, and they lose the greatest part of their animal heat, one of the most marked characters of their class: in a word, their life seems totally arrested; all the springs which retain or set in motion the elements of organisation seem to have lost their activity, and yet life still remains, nay, may be prolonged by that lethargy beyond its natural limits: neither death nor decomposition has taken place; and unless the cold or other accessories of the lethargic state has ceased, the animal awakes and resumes its usual functions.

When the Class proposed, in 1799, that naturalists should consider in detail the circumstances which produce, accompany, and put an end to the lethargic state, it was not expected that a complete solution of the point would be obtained, but merely that the attention of naturalists, when directed to so great an object, might throw some light on it.

The most important memoirs on this subject have appeared in Spallanzani's posthumous Treatise on Respiration, published in 1803, and in 1807 by his friend M. Sennebier. M. Mangali, the pupil and successor of Spallanzani, published some experiments at Pavia, on the same subject*, and Mr. Carlisle, in the Philosophical Transactions for 1803, has thrown much light on the question, although we are not yet perhaps able to solve the question.

* See Philosophical Magazine, vol. xxx. p. 245.

Messrs. Hérholdt and Rafn, of Copenhagen, M. Saissy, a physician of Lyons, and M. Prunelle of Montpellier, have successively presented memoirs of great merit to the Institute, on the torpidity of animals; and we think it right to give here a detail of some of the phænomena, with some hasty conjectures respecting the cause.

Cold is the most necessary accessory to sleep; but it is not the only one: there must also be an absence of irritating causes, such as noise, food, &c. Several of these animals, when domesticated, do not sleep, notwithstanding the cold. An atmosphere deficient in oxygen is also favourable, and frequently necessary. This is the reason that most animals roll themselves up before falling asleep.

The degree of heat, although variable according to the kind of animal and accessory circumstances, is always a little higher than the freezing point: a too violent cold has the effect of awakening animals when they are suddenly exposed to it.

Quadrupeds subject to lethargic sleep have not in general their blood colder than other animals in the ordinary state, nor do they consume less oxygen in respiration: it appears, however, that their heat decreases a little with that of the atmosphere, although it always remains sufficiently high while they are awake.

When once asleep, their breathing and circulation become slower: the consumption of oxygen decreases in the same proportion; they lose all feeling when the lethargy is at its height. Irritability seems to be the function which is best preserved.

Their animal heat decreases in the same interval to one or two degrees above 0° (Reaumur), but it does not become lower; and if we gradually expose the animal to a more violent cold, and it becomes frozen, death ensues.

Warmth is the most natural cause of the animal's awaking: there are other causes, however, and cold is one of them. When the animal awakes from any given cause, respiration and circulation recommence with the usual degree of heat. The profoundness of the sleep is different, according to the species. Some animals awake several times in winter: the bear and the badger are subject to a slight sleep only: the dormouse allows itself to be dissected without exhibiting any signs of pain.

They evacuate their bowels before going to sleep; but they eat during the short times in which they are awake: they transpire but very little. The above are such facts as have been clearly ascertained.

With respect to the predisposing causes, *i. e.* why some animals are subject to sleep in winter and others not; and with respect to the preserving causes, *i. e.* what renders them susceptible of reviving, notwithstanding the suspension of functions which seem most necessary to life,—nothing yet has been advanced which offers a satisfactory solution of these questions.

M. Geoffroy has presented to the Institute some fragments of a great work which he has undertaken upon Comparative Osteology. He endeavours to push further than has been hitherto done, the analogies between the corresponding parts of various vertebral animals,—analogies which Aristotle had already recognised, and upon which he founded his works of Natural History.

M. Latreille, already known by his great work upon Insects in fourteen volumes, published as a supplement to Buffon, has added to his other labours a work in Latin, under the title of *Genera Insectorum et Crustaceorum*, three volumes of which have already appeared, in which he has classed them with method and precision.

M. Dumeril, professor of anatomy in the School of Medicine, the editor of M. Cuvier's Comparative Anatomy, and author of several valuable works, has presented three Memoirs this year to the Institute. In the first he treats of the mechanism of the respiration of fishes, which is nearly the same with that of deglutition in other animals, but it is effected by more complex organs; he points out several interesting singularities, and among others, the way in which lampreys, rays, and several squali take in water; their mouth being fixed to the stones or the sand, cannot be used for this purpose, but it is effected by means of apertures, called *vents*, made in the upper part of their heads, and furnished internally with a valve which admits of water entering when the cavity of the mouth is dilated, but which leaves no other outlet but the gills, when this cavity is shut.

In his second Memoir, M. Dumeril treats of the senses of smelling and taste in fishes. He thinks their tongue is insensible to taste, on account of the dryness and hardness of its integuments, and the continual passage of water over them in respiration; but their pituitary membrane not being susceptible of smell like ours, since it is not affected by elastic vapours, may very probably be the seat of the organ of taste, by transmitting the impression of substances dissolved in water.

The third Memoir is a comparative view of the various vital and animal functions, in the order of reptiles called *Batrachæ*, whence it results that the division of this order into

into two families, proposed by M. Dumeril in his Analytical Zoology, is justified by striking differences in almost all the organical systems.

The crocodile genus has been this year the subject of several Memoirs. Hitherto no correct ideas have been formed even respecting the crocodile of the Nile, which has been the subject of so many wonderful stories; far less were the destructive characters of the various crocodiles known. M. Geoffroy Saint Hilarie has rendered an essential service to natural history by bringing a crocodile of the Nile from Egypt; a circumstance which had the effect of introducing to the public the Saint Domingo crocodile, an animal almost entirely neglected by naturalists. M. Descourtils has presented a complete history of it; being the result of observations made in the West Indies, accompanied by drawings. M. Cuvier, by comparing the information thus communicated with his own previous knowledge, has proved that there exist, in the warm countries of the old and new continent, at least twelve species of these voracious reptiles, distinct from each, and easily recognized: he has exhibited the bodies or skeletons of most of them, and determined their characters.

The same naturalist has directed his attention in an anatomical point of view to some reptiles which truly merit the appellation of *amphibious*, because they breathe by the gills like fishes, and by the lungs also like common reptiles.

One of these, the *siren lacertina*, resembles a kind of eel, with two small fore-feet, each having four toes: its neck is adorned on each side with three small fringes. This animal is found in the rivers of Carolina.

The other, the *proteus anguinus*, is still more extraordinary; its colour is whitish; its gills of a bright red: it has four feet, those in front have three toes, and those behind only two. The eyes are entirely concealed under the skin, and in fact are of no use to it, for it only inhabits some subterraneous waters in Carniola, from which it is vomited forth in great inundations. It is therefore extremely rare even in that country, and has never been found any where else.

The third was brought from Mexico by M. Humboldt. The inhabitants use it as food: it resembles an *aquatic salamander*, and is called *proteus pisciformis*, or *axolotl*.

M. Cuvier's opinion, that the mammoth of Russia, and indeed of the old continent, was a different species from the Indian elephant, is well known. This opinion has been

fully confirmed by the discovery of an almost entire carcase of the former animal near the mouth of the Lena by M. Adams of the Petersburg Academy*.

Zoology has this year been enriched by the labours of M. Biot, the celebrated geometrician. While occupied in the Balearic Islands in measuring an arc of the meridian, he thought he observed that fishes, when suddenly drawn out of the sea by the line from a great depth, expelled a part of their intestines from their mouths: this phænomenon he ascribed to the air-bladder being compressed by the great column of water which it has to support, and which dilating suddenly as the fish rises, tears a part of the intestines, and causes them to rise into the mouth. M. Biot also examined the nature of the air contained in this bladder, and found that it varied from pure azote up to $\frac{87}{100}$ th of oxygen; but there was no appearance of hydrogen. He was of opinion that the oxygen was more abundant in proportion to the depth from which the fish came; and fresh water fish, which frequently swim near the surface, afforded very little of this gas. This last observation has also been made by Messrs. Geoffroy and Vauquelin, and by M. Humboldt, and agrees with the opinion long ago advanced by M. Fourcroy, in a memoir upon the air in the bladder of carps, which he regarded as almost pure azoté.

M. Jurine, correspondent of the class at Geneva, has published a work on hymenopterous insects. He divides this extensive class according to the nerves of the wings, a character which has the advantage of being extremely sensible, and is more natural than might be expected from the small degree of importance attributed to it.

M. Jurine is busied with a similar work on *dipteræ*, or two-winged insects.

PHYSIOLOGY.—M. Dupuytren has presented the Institute some experiments on an important point in physiology, viz.: *the concurrence of the nerves of the lungs in the act of respiration*. The attention of physiologists having been long directed to the chemical part of this animal function, they had too much lost sight of its vital part; and it was supposed that, provided the motion of the sides and of the diaphragm brought the air into the cellular part of the lungs, the blood would be changed from venous to arterial. It had, notwithstanding, been presumed, that the texture of the arteries, and consequently of the nerves therein distributed, must still take an active part in this operation, as well as in

* See Philosophical Magazine, vol. xlix. p. 141.

If the other transformations of the fluids of the animated body. This has been proved by M. Dupuytren, in direct experiments. Horses and dogs, in which he had cut from both sides the nerves peculiar to the pulmonary texture, in vain agitated their pectoral muscles and inspired the air; their blood constantly remained black, and they died as if from asphyxia: and the same nerves, alternately tied with a thread and freed from the ligature, when the texture had not been altered, successively produced the phænomena of arterial and venous colouring.

BOTANY.—M. Labillardiere has finished his *Flora of New Holland*. M. de Beauvois has published a new edition of that of Oware and Bénin, and has given the remainder of his Memoir on the Algæ.

M. de Jussieu continues his examination of certain families, the structure of which he analyses more exactly, and rectifies the distribution, combining his observations with those of Gærtner. New divisions or unions of genera have resulted from his inquiries; and on this head he has this year communicated a memoir, in which he separates from the too numerous genus *justicia*, two genera, which he denominates *dieliptera* and *blechum*.

Both differ from the ordinary *justicia*, from their capsule being divided into forked valves; and the partition between the seed-boxes is but imperfect. The *blechum* in particular is distinguished by four stamina, and by the different structure of its partition.

M. Happel-La-Chesnay, of Guadaloupe, has communicated an interesting observation upon the air-vessels of the *Banana tree*. These vessels are very abundant, and very tough in the stalk of this vegetable; and as the rest of its texture is very tender, they are easily detached. They resemble carded cotton, but it does not appear that cloth can be made with them.

M. Dupetit-Thouars has continued to communicate his inquiries upon the growth of vegetables. He still thinks that the stalk of trees finds in the buds the principle of its growth, and that the fibres, of which the annual layers of wood are composed, are in some measure the roots of the buds, while the small medullary thread which joins each of them, performs the same functions with the cotyledons in the small plant which is germinating*.

To the motives for this opinion, which he had previously detailed, he has added others: he has endeavoured to answer

* See Philosophical Magazine, vol. xxviii. p. 370.

objections, and has intermixed several important facts connected with the physics of vegetables, and of an interest independent of the principal object. Of this number is the germination of the tree called *lecythis* by Linnæus: although belonging to the dicotyledons, the evolution of its seed is not similar to any of the three modes hitherto adopted. Its cotyledon is internal, and serves as a basis to the marrow, which, in the opinion of M. Dupetit Thouars, is a proof in favour of his ideas.

The origin of carbon in plants is one of the most important questions connected with vegetable œconomy. The class a few years ago made it the subject of a prize question without obtaining a satisfactory answer: but the excellent work published since by De Saussure, added to preceding labours of M. Sennebier, has begun to throw great light on this obscure subject. The decomposition of the carbonic acid is displayed amid many complicated transformations, as the chief and predominating act of vegetation, and as the primitive source of vegetable carbon.

M. de Crell, a celebrated chemist residing at Helmstadt, has this year communicated to the class some experiments which afford a most exalted idea of the power of vegetation: he informs us that he has raised plants in pure sand, so as to bear fruit: they were watered with distilled water only, and supplied with a determinate quantity of air, in which the carbonic acid must have been almost null, compared to the quantity of carbon produced. Vegetables must therefore have, according to M. Crell, the power of composing carbon, employing for this purpose only water, atmospheric air, and light. This would be one of the greatest discoveries in chemistry; but unfortunately this respectable chemist has not taken the necessary precautions for demonstrating his assertion with the precision requisite on such an important occasion: even when he covered his plants with a bell-glass, it was out of his power to prevent the access of the external air through the sand on which the bell-glass rested; and as the external air is continually in motion, it is very difficult to estimate the quantity of carbonic acid which it can furnish.

CHEMISTRY.—Messrs. Fourcroy and Vauquelin continue with unabated ardour their *Analyses of the Productions of organised Bodies*, and their remarks on the transformations which these productions are capable of undergoing: by these labours they have established relations of the utmost importance between chemistry and physiology, and have thrown a great deal of light on the latter.

The juice of onions presented a sharp, volatile and odorous oil, sulphur, plenty of saccharine matter and of mucilage, a vegeto-animal matter coagulable by heat, phosphoric and acetic acid, calcareous phosphate and citrate, which last had not been previously discovered in vegetables. It is this oil which gives onions their sharp taste previous to their being dressed, and which irritates the eyes; and it is the sulphur they contain which blackens silver articles, and contributes to the smell which onions give out when in a state of putrefaction.

The free phosphoric acid being capable of dissolving the phosphate of lime, would perhaps be useful as a remedy against calculi of the bladder: and this has given rise to an opinion that onion juice is an excellent medicine for the stone. Calculi of uric acid and of oxalate of lime are unfortunately, however, unattackable by it. The acetous fermentation of onion juice develops a kind of manna, differing from the saccharine matter from which it is separated, in so far as the proportion of hydrogen and carbon is more considerable.

The milt of fresh-water fishes presented to these indefatigable chemists an important fact, and one entirely new in the annals of science. The above substance contains native phosphorus, which is so intimately combined with it that it remains united to its carbon after a total decomposition, forming a true carburet of azoted phosphorus. Human bones of the eleventh century, dug up from the old church of St. Geneviève, and analysed by the same chemists, were found dyed of a fine purple colour and covered with an efflorescence of phosphoric acid and acid phosphate of lime. Messrs. Fourcroy and Vauquelin are of opinion, from this observation, that the exhibition of the phosphoric acid might rather be one of the methods employed by nature for decomposing the bones and restoring them completely to the earth.

[The report next details Mr. Davy's discoveries, which have been already submitted to our readers.]

M. de Morveau has attempted to apply Galvanism to certain interesting and obscure phænomena in the mineral kingdom; and particularly to the transition of a sulphuret to the state of oxide, without any alteration of its primitive form: some subterraneous production of electricity seemed to him to explain the facts; and on subjecting some sulphurets to the action of the pile, they exhibited the same metamorphose.

We know that of all the phænomena of the mineral kingdom the most perplexing perhaps is that of stones falling

from the atmosphere; and every thing is so new on the subject, that it ought not to excite our astonishment that various explanations are still sought after.

We alluded last year to the remark of M. Vauquelin, that several metallic substances, very similar to atmospheric stones, are evaporated from lofty furnaces.

M. Seguin has endeavoured to collect all the analogous facts known in chemistry or medicine, such as the deleterious vapours of lead, mercury, the phænomena of salts diffused in air, vapour, rain-water, &c.; all the metallic or other substances which hydrogen gas can dissolve; the quantity of odours, and of miasmata, not recognisable by our eudiometers. From all these M. Seguin easily proves that the composition of the atmosphere is very little known to us, and that several of its vapours being very light may be accumulated in the upper regions; but the difficulty of uniting a sufficient quantity before their falling down, in order to form aërolites of the size generally observed, remains unsolved.

M. Theodore de Saussure has presented a very interesting analysis of alcohol and sulphuric ether. He operated by combustion, both with alcohol by itself and in the state of vapour: by means of decomposition by simple heat, he determined the quantity of water and of carbonic acid produced, as well as the respective quantities of their elements in oxygen, carbon, and water: finally, he has drawn a mean result from all his operations, and concluded the composition of alcohol to be as follows:

Carbon	-	-	0·4565
Oxygen	-	-	0·3785
Hydrogen	-	-	0·1494
Azote	-	-	0·0352
Cinder (Cendre)			0·0004

1·0000

And that of ether:

Carbon	-	-	0·583
Hydrogen	-	-	0·2214
Oxygen	-	-	0·1966

1·0000

Finally, he shows that these two analyses agree with the quantity of ether furnished by a given quantity of alcohol, and by the analysis of what remains after etherification.

This

This memoir, more precious on account of the new chemical methods which it has suggested than by its direct results, also contains several interesting remarks; and among others this particular one, that vapours are heavier in proportion as the liquids they are produced from are more volatile.

The theory of sulphuric ether formerly given by Fourcroy and Vauquelin is therefore confirmed in this respect, that the acid forms no part of the composition of this liquid.

But this is not the case with respect to ethers formed by the action of the volatile acids upon alcohol: the acid enters into the combination, either completely formed, or by means of its elements. M. Thenard had proved this last year, with respect to the nitric ether. He afterwards extended his inquiries to the muriatic and acetic ethers, and showed that acid is to be met with in them, either from the effects of time or of combustion, although it is in these cases so well disguised, that neither the alkalis nor the other known reagents do separate it from them at their first formation. In these cases, Does it exist in an entire state, or decomposed in its elements? This question is of difficult solution, notwithstanding its interesting nature, so far as the muriatic acid is in question. M. Boulay, however, having succeeded after an interval of time in absorbing the muriatic ether by ammonia, and having distinctly and separately extracted alcohol and muriate of ammonia, thinks that the acid and the alcohol were simply combined together; and he extends this conclusion to the nitric and acetic ethers.

M. Boulay has also succeeded in preparing *phosphoric ether*, the theory of which brings us back to that of the sulphuric ether.

M. Vauquelin continues his important analysis of the different kinds of iron, and his inquiries into the ingredients which occasion the bad qualities of some of them.

One kind of iron, which broke when hot in the hands of some workmen, while in the hands of others it was passable, only yielded one six-hundredth part of phosphorus, and a four-hundredth part of chrome. Another kind of iron which crumbled under the hammer at a white heat, and which presented a grain like that of steel, without its hardness, contained one three-hundredth part of arsenic and one hundredth part of phosphorus.

M. Vauquelin is at present occupied with inquiring by what means we may free iron from principles of which such a small quantity alters the quality of the metal.

M. Gay-

M. Gay-Lussac has undertaken a laborious investigation, with a view of appreciating *the action of the fire upon the different sulphates and sulphurets, and in order to determine the circumstances in which the sulphuric acid is found completely formed or decomposed.* He found that this decomposition is effected in the metallic sulphates, in which the acid is more tenaciously retained, and that there then pass over sulphurous acid and oxygen; but this last phænomenon does not take place where the acid is feebly-condensed.

As to the sulphurets, they always give sulphurous acid at a very high temperature; but at a low temperature they give more sulphuric acid, as the oxide of their metal has more affinity for it. The earthy sulphates and that of ammonia always admit of their acid being decomposed; but those of the fixed alkalis only do so when their acid is in excess. The acid alone is very well decomposed by simple heat. From these inquiries results the analysis of the two acids of sulphur; 100 parts of this combustibile take 50.61 of oxygen before being converted into sulphurous acid, and 85.70 before becoming sulphuric acid.

We have also, as one of the above results, an explanation of several complex chemical phænomena, and particularly those which take place at the manufacture of sulphuric acid by the combustion of sulphur in leaden chambers. Sulphur alone would give sulphurous acid only; but the nitre which we burn with, and the atmospheric air admitted, furnish the superabundant oxygen. Water is a necessary intermedium for uniting the oxygen of the air to sulphurous acid, as M. Fourcroy long ago announced.

M. de Morveau has made some curious experiments upon the time necessary for the inflammation of a given mass of gunpowder, and the effects which result from it. Coarse powder inflames more speedily than fine. The ordinary working of a gun requires that the ball should run freely into the piece, and the space required for this purpose greatly diminishes the strength of the powder. But it is singular that by diminishing this interval of room in a gunpowder proof, and making the ball fit very accurately, a still greater loss takes place; probably because the explosion, by momentarily compressing the globe in the longitudinal direction, dilated it in the transverse direction; and in this case there was too violent a friction of bronze against bronze. Experience having shown that leaden bullets pressed into carbines have not this fault, M. de Morveau tried bullets made cylindrical behind, and furnished with a leaden ring, which he found

found very advantageous; but as it requires more time to load a gun in this way, they can only be employed in fixed batteries.

Count Rumford has communicated some curious experiments relative to the general action of affinities, and which prove that two liquids may continue a long time superposed without being completely mixed, although predisposed by nature. A saturated solution of sea salt was covered with distilled water: a drop of oil of rosemary heavier than fresh, and lighter than salt water, kept between both, and served as an index for the progress of the mixture, ascending about two or three lines *per diem*.

XXII. Intelligence and Miscellaneous Articles.

MERINO SHEEP.

ALL persons who possess ewes of pure Merino race, and are desirous of increasing their stock, are requested to apply to Sir Joseph Banks, who has received the king's commands to distribute a considerable flock, newly imported from Spain, among such persons as are most likely to preserve them free from all admixture, and to improve their form by judiciously matching them in breeding; giving a due preference to those who have manifested their approbation of this kind of stock, by having already provided themselves with the breed, but who have not yet obtained a sufficient increase to be able to supply the wants of their neighbours who wish to improve their British wools by the use of this valuable cross.

Letters addressed to Sir Joseph Banks, Soho-Square, London, will be duly attended to. He requests to be correctly informed of the actual number of pure Merino ewes, ewe tegs, and ewe lambs, each applicant is now in possession of, and of the source from whence the breed was originally procured.

Sir Joseph Banks will be thankful to gentlemen who will inform him what was the average weight of the pure Merino fleeces of the clips of 1808 and 1809, and what price per pound they were sold for, with the name of the purchaser.

Mr. Wm. Curtis, of the Botanic Garden, Brompton, has lately been rewarded by the Society of Arts, &c. &c., for his valuable application of the Long White Moss of the Marshes (the *Sphagnum palustre* of Linnæus) to the packing

ing of young fruit- and other trees for exportation. He does this by squeezing out part of the moisture from the moss, and laying courses of it about three inches thick, interposed with other courses of the trees, (previously shortened in their branches and roots,) stratum super stratum, until the box is filled, when the whole must be trodden down, and the lid properly secured. The trees will need no care even during a voyage of ten or twelve months; the moss being wonderfully retentive of moisture, and seeming to possess an anti-septic property which totally prevents fermentation or putrefaction from taking place; and, in fact, vegetation actually proceeds during the time the trees remain so inclosed; shoots being formed both from their branches and roots, which, however, are blanched and tender, for want of light and air; and, in consequence, the trees, on being planted, require to be gradually inured to the open air. This moss is very common in most parts of Europe and America, which renders this application of it more facile, and the discovery more important.

The following is an illustration of a well know fact, that the general tendency of currents in the ocean is from the East towards the West:—

(COPY.)

“Neptune, St. John’s Roads, Antigua,
June 29, 1809.

“SIR,—As the inclosed letters*, picked up in a bottle, on the windward part of the island of Martinique, on the 18th of April last, tend to elucidate the state of the current in the Atlantic Ocean, I inclose them to you, with a request that you will be pleased to make the circumstance known to the lords commissioners of the admiralty.

“The bottle appears to have been thrown overboard by the Princess Elizabeth packet, going to the Brazils, on the 6th of September 1808, in lat. 14.45, and long. 25, and it must have been carried about 2020 miles in 224 days, which gives nine miles per day on a west course.—I am, &c.

(Signed) ALEX. COCHRANE.”

“W. W. Pole.”

Without being profoundly skilled in subjects of this nature, we should apprehend that the rotatory motion of the earth, from west to east, will, where local circumstances do not operate, necessarily produce a bearing of the fluid element in a contrary direction, and occasion the general tendency of currents to be from east to west. To this it may

* Several letters were found in the bottle addressed to individuals.

be added, that the water will naturally incline to follow the sun in his diurnal motion, from the attractive force of this body acting upon a yielding substance.

In a short time will be published a new edition of Nicholson's Principles of Architecture, corrected and improved by the author, with the addition of two new plates; forming three volumes, octavo, containing 218 plates, engraved by Lowry and others.

LECTURES.

St. Thomas and Guy's Hospitals.

The Winter Courses of Lectures at these adjoining Hospitals will commence as usual, the beginning of October, viz.

At St. Thomas's.—Anatomy and the Operations of Surgery, by Mr. Cline and Mr. Cooper.—Principles and Practice of Surgery, by Mr. Cooper.

At Guy's.—Practice of Medicine, by Dr. Babington and Dr. Curry.—Chemistry, by Dr. Babington, Dr. Marcet, and Mr. Allen.—Experimental Philosophy, by Mr. Allen.—Theory of Medicine, and Materia Medica, by Dr. Curry and Dr. Cholmeley.—Midwifery, and Diseases of Women and Children, by Dr. Haighton.—Physiology, or Laws of the Animal Economy, by Dr. Haighton.—Structure and Diseases of the Teeth, by Mr. Fox.

N. B. These several Lectures are so arranged, that no two of them interfere in the hours of attendance; and the whole is calculated to form a complete Course of Medical and Chirurgical Instructions. Terms and other Particulars may be learnt at the respective Hospitals.

Dr. Buxton's Autumnal Course of Lectures on the Theory and Practice of Medicine will be commenced the second of October, at the Medical Theatre, London Hospital.

Mr. Taunton's Autumnal Course of Lectures on Anatomy, Physiology, Pathology, and Surgery, will commence on Saturday, October 7, at eight o'clock in the Evening, and will be continued every Tuesday, Thursday, and Saturday, at the same hour. Particulars may be had on applying to Mr. Taunton, Greville Street, Hatton-Garden.

METEOROLOGY.

The subjoined Table and Remarks has been handed to us as the result of forty years observations made by Dr. Herschel.

“The following Table, constructed upon a philosophical consideration of the attraction of the sun and moon in their several positions respecting the earth, and confirmed by the experience

experience of many years actual observation, will, without trouble, suggest to the observer what kind of weather will most probably follow the moon's entrance into any of her quarters, and that so near the truth, that in very few instances will it be found to fail.

Moon.	Time of Change.	In Summer.	In Winter.
If the New Moon, the first quarter, the Full Moon, or the last quarter, happen	At Noon	Very Rainy . . .	Snow or Rain.
	Between 2 & 4 P.M.	Changeable . . .	Fair and Mild.
	4—6	Fair	Fair.
	6—8	{ Fair if Wind N. W.	Fair and Frosty if N. or N. E.
	8—10	{ Rainy if S. or S. W.	Rain or Snow if S. or S. W.
	10 & Midnight . . .	Ditto	Ditto.
	Midnight & 2 A. M.	Fair	Fair and Frosty.
	2 and 4	Ditto	Hard Frost, unless Wind S. or W.
	4 and 6	{ Cold with frequent	} Snow and Stormy.
	6 and 8	{ Showers	
8 and 10	Rain	Ditto.	
10 and Noon	Wind and Rain . . .	Stormy.	
	Changeable	Cold Rain if W., Snow if E.	
	Frequent Showers . .	Cold with high Wind.	

“Hence the nearer the time of the moon's change, full and quarters, is to midnight, (that is within two hours before or after midnight) the more fair will the weather for that quarter be in summer—but the nearer to noon the less fair.

“Also the moon's full, change, and quarters happening during six of the afternoon hours, viz. from 4 to 10, may be followed by fair weather, but this is mostly dependent on the wind. The same changes during all the hours after midnight except the two first, are unfavourable to fair weather—The like nearly may be observed in the winter.”

Rain Table, by the Rev. J. BLANCHARD, of Nottingham.

1808.	Chichester.	London.	Bristol.	Cheltenham.	West Bridgford near Nottingham.	Horncastle, Lincolnshire.	Chatsworth, Derbyshire.	Manchester.	Ferriby, Kingston-upon-Hull.	Heath, near Wakefield, York-shire.	Lancaster.	Dalton, Lancashire.	Kendal.	Edinburgh.
Jan.	3.04	1.52	1.05	0.80	2.85	0.93	1.39	2.70	0.59	1.14	2.90	3.85	5.25	1.67
Feb.	0.90	1.12	0.53	0.20	2.23	0.77	1.35	1.48	0.92	1.26	2.00	1.85	2.42	2.31
Mar.	1.42	0.20	0.45	0.05	1.30	0.43	0.37	0.24	0.29	0.99	0.00	0.55	0.28	0.65
April	2.67	2.42	5.37	5.05	2.01	3.55	2.57	1.32	2.47	3.49	1.51	1.78	3.80	3.04
May	1.72	1.58	2.99	1.30	2.45	1.65	1.68	1.76	2.01	3.08	2.38	4.14	3.95	1.99
June	1.51	0.78	1.75	5.10	2.20	1.18	3.25	2.05	1.21	2.34	1.25	1.84	2.02	2.61
July	5.67	3.22	2.76	---	1.45	2.50	3.71	2.44	3.24	5.44	4.12	3.91	4.85	2.45
Aug.	2.69	0.96	3.06	---	1.92	1.69	2.12	2.18	2.44	2.66	3.75	4.87	5.37	7.51
Sept.	4.87	4.18	4.36	---	2.45	1.53	3.80	2.71	3.25	3.03	1.22	3.05	2.62	2.50
Oct.	6.41	3.82	5.26	---	1.82	2.77	3.95	5.32	2.99	2.49	7.08	6.53	7.25	2.01
Nov.	2.92	2.18	3.04	---	0.80	3.20	2.60	3.10	2.51	3.16	4.27	5.20	3.92	0.74
Dec.	2.80	1.00	1.52	---	1.74	4.10	1.98	1.79	5.01	2.91	1.69	2.89	2.61	1.93
Total	36.63	22.95	32.05	12.60	23.22	24.32	28.81	27.09	26.95	20.99	32.46	39.99	43.34	29.34

Meteorological Table, by Dr. CLARKE, of Nottingham.

1850s.	Thermometer.				Barometer.				Weather.		Winds.				Rain.	
	Highest.	Lowest.	Mean.	Greatest Variation in 24 Hours.	Highest.	Lowest.	Mean.	Greatest Variation in 24 Hours.	Fair.	Wet.	N. & N. E.	E. & S. E.	S. & S. W.	W. & N. W.	Inches.	Decimals.
Jan.	49 17	38 17	19	19	30 39	28 97	29 70	85	30 11	2	3	51	33		1 40	
Feb.	55 22	38 65	13	13	30 74	29 42	30 05	57	21 8	21	3	21	42		54	
March	52 32	40 21	6	6	30 39	29 57	30 12	31	23 5	65	16	11	12		58	
April	56 30	13 62	10	10	30 20	29 07	29 75	51	13 17	14	2	21	43		3 85	
May	52 45	59 61	11	11	30 17	29 47	29 54	24	21 10	21	20	11	11		1 94	
June	72 50	59 95	9	9	30 25	29 62	29 91	30	19 11	18	26	12	27		2 32	
July	89 54	67 19	12	12	30 16	29 54	29 89	21	24 7	19	17	36	21		2 10	
Aug.	76 53	64 62	10	10	30 17	29 35	29 78	71	20 11	7	9	12	35		91	
Sept.	65 10	57 32	9	9	30 25	29 35	29 76	33	19 11	29	7	26	25		2 37	
Oct.	60 34	46 31	10	10	30 32	28 96	29 63	91	19 12	10	6	10	37		2 57	
Nov.	55 30	45 06	13	13	30 25	28 72	29 76	68	17 13	26	17	26	23		2 45	
Dec.	49 24	37 96	14	14	30 26	29 08	29 76	55	21 16	30	4	27	32		1 80	

ANNUAL RESULTS.

THERMOMETER.		WIND.	BAROMETER.		WIND.
Highest Observation, July 13, 89°SW.		Highest Observation, Feb. 25, 30°74N.	Lowest Observation, Nov. 18, 28°72SE.		
Lowest Observation, Jan. 22, 17°SW.		Greatest Variation in 24 Hours,		Greatest Variation in 24 Hours,	
Jan. 22, 23, - - - - 19°		Oct. 13, 14, - - - - 91		The Mean, - - - - 29 84	
The Mean, - - - - 49 88		The Mean, - - - - 29 84			
WEATHER. DAYS.		WINDS.	TIMES.	RAIN.	
Fair - 237		N. & NE. - 262		Greatest Quantity in April, 3 85	
Wet - 128		E. & SE. - 128		Smallest ditto in February 54	
		S. & SW. - 356			
		W. & NW. - 352		Total - 22 56	

1098

REMARKS.—The town of Nottingham is situated in latitude 52° 59' 35" North, and in 1° 7' 0" longitude West of London. It rises with much grandeur from the banks of the small river Leen, gradually increasing its elevation as it extends to the N.E. so that above one-half stands on a considerable eminence; the foundation is a soft sand stone rock, easily excavated, and forming excellent cellars. The buildings are chiefly of brick, and commonly three or four stories high. The streets are, in general, narrow. The neighbourhood produces an ample supply of coal, which is the only fuel used in the town. The Trent, a fine navigable river, flows from West to East, within a mile of the town; it is subject to very sudden swells, which sometimes produce floods that inundate the meadow ground between the river and the town, the atmosphere must be, in some measure, influenced by the evaporation that follows, as well as by the dense haze over the river in summer evenings, and the thick fogs of winter.

The barometer, thermometer, and pluviometer (or rain-gauge), are new instruments, made by Jones, of Holborn. The thermometer, on Fahrenheit's scale, is placed outside a window, facing the West, in the centre of the town, but in a situation protected from currents of air, or reflected heat. The observations were made daily, at 8 A.M. 2 P.M. and 11 P.M. and from them the averages are deduced. The barometer (of the portable kind) is firmly fixed to a standard wall over a stair-case, on a level of 130 feet above the sea. The observations were taken daily at 2 P.M. and from these the mean was obtained. The pluviometer is placed in a garden, on an elevation of 140 feet above the level of the sea, where it cannot be affected by buildings, or gusts of wind. The observations are taken at the end of each month. The observations on the wind were made at 8 A.M. 2 P.M. and at dusk, from the vane of a church steeple, the most elevated part in the town.

METEOROLOGICAL TABLE,
 BY MR. CAREY, OF THE STRAND,
 For August 1809.

Days of the Month.	Thermometer.			Height of the Barom. Inches.	Degrees of Dryness by Leslie's Hygrometer.	Weather.
	8 o'Clock, Morning.	Noon.	11 o'Clock, Night.			
July 27	62°	72°	61°	29·75	25	Fair
28	63	69	55	·65	31	Showery
29	56	66	56	·75	22	Showery
30	61	69	57	·61	39	Cloudy
31	56	69	58	·55	42	Fair
August 1	59	68	59	·70	50	Fair
2	58	68	56	·65	53	Fair
3	57	68	53	·39	51	Showery
4	55	59	52	·54	0	Rain
5	55	63	57	·75	5	Showery
6	60	68	55	·39	31	Showery
7	57	67	60	·77	52	Cloudy
8	63	69	59	·93	58	Fair
9	60	72	61	·90	61	Fair
10	64	76	68	·85	67	Fair, Thunder in the night
11	67	76	60	·75	61	Fair
12	57	62	56	·69	25	Showery
13	58	65	55	·80	24	Showery
14	57	66	57	·80	42	Showery
15	58	68	60	·79	30	Cloudy
16	60	71	60	·92	30	Cloudy
17	64	75	60	·83	66	Fair
18	59	76	59	·78	35	Fair, Rain in the morning
19	62	69	57	·75	51	Fair
20	60	68	56	·98	41	Showery
21	60	65	54	·80	10	Rain
22	55	66	57	·80	51	Fair
23	56	66	55	·56	57	Fair
24	55	66	50	·48	45	Showery with Thunder
25	54	61	49	·49	30	Showery with Thunder
26	54	62	54	·79	22	Showery

N. B. The Barometer's height is taken at one o'clock.

XXIII. *Meteorological Observations on a Thunder Storm; with some Remarks on Medical Electricity.* By Mr. CORNELIUS VARLEY.

To Mr. Tilloch.

SIR, I TAKE the liberty of sending you a description of a distant thunder storm*, the electrical phænomena of which were so distinctly visible as to leave no doubt on my mind of the exclusive agency of one electric fluid. (See Plate VI).

Observing it to lighten one evening frequently without hearing thunder, I went into the fields, and, looking northward, saw the horizon lined with clouds, there being none over head except a few very small ones proceeding in that direction. These were upon a level with the lower cloud; for they joined it afterward—a circumstance which serves to prove that a diminution was taking place in the volume of the atmosphere, for otherwise they could not have overtaken the storm, being at first too far off to be affected by any electrical attraction. At the commencement of the storm it lightened in various parts of the clouds, but more frequently in one place. Soon after this the clouds seemed united in one, and the place of the lightning became stationary, (where in the drawing the light cloud is placed,) and here commenced the effect which seemed distinctly to show in what manner the electric fluid is conducted from the upper regions to the earth.

At first a small round cloud (about an eighth part of that represented) appeared behind the long dark cloud, and partly seen above it. In this cloud it frequently lightened; and just after the light was extinguished, the electric sparks struck to the earth from the under surface of the long black cloud. This double transmission was many times repeated, till at length the lower cloud ceased to give sparks to the earth at the spot immediately under the higher cloud, though it was still frequently receiving them from it. I then found, by casting my eye along the lower cloud, that every charge from the upper one travelled about four miles westward along the lower cloud, and then darted to the earth. I knew it travelled in this manner by frequently seeing it jump over one and sometimes over two chasms in the lower cloud in its passage to the western end. The time it took to travel the length above mentioned, was while I could count 20 or 30—but twice I counted 60 before it struck the earth.

* This is commonly called summer lightning, i. e. there is fine weather over head, and the lightning is so far off that the thunder cannot be heard.

During the time of these observations, the higher cloud, which supplied so much electricity, was not diminished in the least. On the contrary, it continued to enlarge in its dimensions, and chiefly towards the wind, as may be seen by its overhanging in the sketch.

Now the quantity of electricity supplied by this cloud continually during an hour, was probably 50 times as much as it could possibly contain. The question then is: Where did it come from? The increasing of the cloud furnishes an answer to this question; for it could not increase without the addition of vapour, and that addition could come only from the atmosphere. This was proved by the manner and place of increase, which was at the top, and at the most prominent parts facing the wind. That vapour, being transparent, had the highest charge of electricity. The upper cloud (though positive to the under) was minus to that vapour, and silently attracting from it the superabundant electricity, which it gave off visibly to the under cloud, which was still less charged, and which was kept so by the earth (which may be considered as quite negative) immediately drawing away that charge in sparks.

Now it is evident by this progress of the electric fluid to the earth, that the electrified vapour must have been condensed to the smaller compass of the cloud, and have been deposited on its surface, occasioning that very great increase of cloud. This seems to show that a storm of lightning will always occasion a current of wind from the external regions towards itself; and hence a dead calm preceding a storm, and the fall of the barometer, as this is the focus of condensation.

I have since repeatedly, in stormy weather, seen clouds, under this effect of increase, sometimes increasing at one end, and diminishing at the other by slow rain, when near a mountain; but I have seldom seen the theoretic form (if I may be allowed the expression) so evident (except among mountains, where it is unlimited, but the lightning rarely seen,) as in the case I have stated: nor can this conformation ever be seen but when the barometer is low or falling.

The lower cloud was three or four times as long, in proportion, as it is represented in the drawing, in which it is necessarily shortened for the convenience of exhibiting both of its ends.

Before concluding, I beg leave to add a few thoughts on the medical action of electricity.

First, I think that electricity entering the body by a good conductor in contact, and going out by another in contact, produces

produces the smallest effect of all, and does but little good or harm.

Secondly, If it enters the body by a conductor in contact, and has to escape in the manner of perspiration, a strong effect is produced; and this may be confined to one place, and of course be rendered more powerful by the attracting points.

Thirdly, An effect equally strong, but quite the reverse of the last, will be produced by placing the patient insulated in contact with the negative conductor, and in a damp atmosphere*. By this mode of operating the effect takes place all over his body: but if, instead of this, you bring a wet sponge, connected with the earth, near the part affected, it will be confined to that place.

In the former case the electricity acts by increasing the natural perspirations, but in the latter, by strongly checking it, or occasioning an absorption of moisture.

I think the failures in medical electricity have been where this last application was wanted; for electricity alone, applied in any way, has a tendency to dissipate moisture; which effect the last method enables you to reverse.

Paddington, Aug. 3, 1809.

XXIV. *An Account of a Method of dividing astronomical and other Instruments, by ocular Inspection; in which the usual Tools for graduating are not employed; the whole Operation being so contrived, that no Error can occur but what is chargeable to Vision, when assisted by the best optical Means of viewing and measuring minute Quantities.* By Mr. EDWARD TROUGHTON.

[Concluded from p. 95.]

RESPECTING the angular value of the numbers in these tables, it may be worth mentioning, that it is not of the least importance; 100 of them being comprised in one revolution of the micrometer screw; and, in the instance before me, 5.6 of them made no more than a second. It is not pretended that one of these parts was seen beyond a doubt, being scarcely $\frac{1}{54000}$ th of an inch, much less the tenths, as exhibited in the tables; but, as they were visible upon the micrometer heads, it was judged best to take them into the account.

* A damp atmosphere is easily produced by using a pan of boiling water; but in this case the machine, that it may be kept dry, should be in another room, and the conductor should pass, insulated, through the wall to the patient.

Having now completed the two first sections of my method of dividing; namely, the first, which consists of making 256 small round dots; and the second, in finding the errors of those dots, and forming them into a table;—I come now to the third and last part, which consists in using the erroneous dots in comparison with the tabulated errors, so as ultimately to make from them the true divisions.

It will here be necessary to complete the description of the remaining part of the apparatus. And first, a little instrument which I denominate a subdividing sector presents itself to notice. From all that has hitherto been said, it must have been supposed that the roller itself will point out, upon the limb of the instrument to be divided, spaces corresponding to others previously divided upon itself, as was done in setting off the 256 points: but, to obviate the difficulty of dividing the roller with sufficient exactness, recourse was had to this sector; which also serves the equally important purpose of reducing the bisecting points to the usual division of the circle. This sector is represented in half dimensions by Fig. 5: it is formed of thin brass, and centred upon the axis at A, in contact with the upper surface of the roller: it is capable of being moved round by hand; but, by its friction upon the axis and its pressure upon the roller, it is sufficiently prevented from being disturbed by accident. An internal frame BB, to which the arc CC is attached, moves freely in the outer one, and by a spring D is pushed outwards, while the screw E, whose point touches the frame B, confines the arc to its proper radius. The arc of this sector is of about four times greater radius than the roller, and upon it are divided the spaces which must be transferred to the instrument, as represented on a magnified scale by Fig. 4. Now, the angle of one of the spaces of the circle will be measured by sixteen times its angular value upon the sectorial arc, or $22^{\circ} 30'$; but this does not represent any number of equal parts upon the instrument, whose subdivisions are to be $5'$ each; for $\frac{1^{\circ} 24' 22'' 5}{5}$ is exactly $16\frac{2}{3}$ ths, therefore so many divisions are exactly equal to a mean space between the dots whose errors have been tabulated. Let, therefore, the arc of the sector be divided into 16 spaces of $1^{\circ} 20'$ each, and let a similar space at each end be subdivided into eight parts of $10'$ each, as in Fig. 4; we shall then have a scale which furnishes the means for making the true divisions, and an immediate examination at every bisecting point.

I have

I have always divided the sector from the engine, because that is the readiest method, and inferior to none in point of accuracy, where the radius is very short; but, as it is more liable than any other to central error, the adjustment of the arc by the screw E becomes necessary: by that adjustment, also, any undue run in the action of the roller may be reduced to an insensible quantity*.

When the utmost degree of accuracy is required, I give the preference to dividing by lines, because they are made with a less forcible effort than dots are; and also because, if any small defect in the contexture of the metal causes the cutter to deviate, it will, after passing the defective part, proceed again in its proper course, and a partial crookedness in the line will be the only consequence; whereas a dot, under similar circumstances, would be altogether displaced. But, on the other hand, where accuracy has been out of the question, and only neatness required, I have used dots; and I have done so, because I know that when a dot and the wire which is to bisect it are in due proportion to each other, (the wire covering about two-thirds of the dot,) the nicest comparison possible may be obtained. It may be further observed, that division by lines is complete in itself; whereas that by dots requires lines to distinguish their value.

On the upper side of Fig. 1. is represented the apparatus for cutting the divisions. It consists of three pieces J K L, jointed together so as to give to the cutter an easy motion for drawing lines directly radiating from the centre, but inflexible with respect to lateral pressure; *dd* are its handles. The cutting point is hidden below the microscope H; it is of a conical form, and were it used as a dotting point, it would make a puncture of an elliptical shape, whose longer diameter would point towards the centre. This beautiful contrivance, now well known, we owe to the ingenuity of the late Mr. Hindley of York; it was borrowed by Mr. Ramsden†, and applied with the best effect to his dividing engine.

It might have been mentioned sooner, that in the instance which I have selected as an example of my dividing, the operation took place when the season of the year, and the smoke of London, had reduced the day to scarcely six hours of effective light; and rather than confine my labours

* See note page 166.

† This I learned from that most accurate artist Mr. John Stancliffe, who was himself apprentice to Hindley.

within such narrow limits, I determined to shut out the day-light altogether. Fig. 7. shows the construction of the lanterns which I used. A very small wick gave sufficient light, when kept from diverging by a convex lens; while the inclining nassel was directed down exactly upon the part looked at, and the light, having also passed through a thin slice of ivory, was divested of all glare. I enter into this description, because, I think, I never saw my work better, nor entirely to so much advantage as in this instance; owing, perhaps, to the surrounding darkness allowing the pupil of the eye to keep itself more expanded, than when indirect rays are suffered to enter it. The heat from a pair of these lanterns was very inconsiderable, and chiefly conducted along with the smoke up the reclining chimney.

Previous to cutting the divisions, the parts now described must be adjusted. The cutting apparatus must be placed with the dividing point exactly at the place where the first line is intended to be drawn, and clamped, so that the adjusting screw may be able to run it through a whole interval. The microscope H must be firmly fixed by its two pillars *bb* to the main frame, with its micrometer head at zero; and with its only wire in the line of the radius, bisecting the first of the 256 dots. And it should be observed, that the cutting frame and this must not vary respecting each other, during the time that the divisions are cut; for any motion that took place in either would go undiminished to the account of error. The microscope I is also fastened to the main frame; but it is only required to keep its position unvaried, while the divisions of the sector pass once under its notice; for it must have its wire adjusted afresh to these divisions at every distinct course. The microscope I has two wires, crossing each other at an angle of about 40° ; and these are to be placed so as to make equal angles with the divisions of the sector, which are not dots, but lines. The sectorial arc must also be adjusted to its proper radius by the screw E, Fig. 5; *i. e.* while the main frame has been carried along the circle through a mean interval shown by H, the sector must have moved through exactly $16\frac{1}{2}$ ths of its divisions, as indicated by I*.

Things

* For the sake of simplicity, the account of the process is carried on as if the roller measured the mean interval without error: But it was said (page 84) that the roller, in a continued motion quite round the circle, would in some part of its course err by $30''$ or more; therefore, when that is the case, an extreme run of the roller cannot agree with a mean interval of the circle nearer than $\frac{30''}{128} = 0'.23$; and most probably this kind of error will

Things being in this position; after having given the parts time to settle, and having also sufficiently proved the permanence of the micrometer H and the cutting frame with respect to each other, the first division may be made; then, by means of the screw for slow motion, carry the apparatus forward, until the next line upon the sector comes to the cross wires of I; you then cut another division, and thus proceed until the 16th division is cut, = $1^{\circ} 20'$: Now the apparatus wants to be carried further, to the amount of $\frac{7}{8}$ ths of a division, before an interval is complete; but at this last point no division is to be made; we are here only to compare the division on the sector with the corresponding dot upon the instrument. This interval, however, upon the circle will not be exactly measured by the corresponding line of the sector, which has been adjusted to the mean interval, for the situation of the dot $1^{\circ} 4'$ is too far back, as appears by the table of real errors, by -4.8 divisions of the micrometer head. The range of the screw for slow motion must now be restored, the cross wires of H set back to -4.8 divisions, and the sector moved back by hand, but not to the division 0 where it began before; for, as it left off in the first interval at $\frac{7}{8}$ ths of a division, it has to go forwards $\frac{1}{8}$ th more before it will arrive at the spot where the 17th division of the instrument $1^{\circ} 25'$ is to be made, so that in this second course it must begin at $\frac{1}{8}$ th short of 0. Go through this interval as before, making a division upon the circle at every one of the 16 great divisions of the sector; and H should now reach the third dot, allowing for a tabular error of -10.2 when the division $\frac{5}{8}$ ths of the sector reaches the cross wires of I. It would be tedious to lead the reader through all the variety of the sector, which consists of eight courses; and it may be sufficient to observe, that at the commencement of every course, it must be put back to the same fraction of a division which terminated its former one; and that the wire of the micrometer H must always be set to the tabular error belonging to every dot, when we end one interval and begin another. The eight courses of the sector will have carried us through $\frac{1}{4}$ th part of the circle, $11^{\circ} 15'$, and during this time, the roller will have proceeded through half a revolution; for its close contact with the limb of the circle does not allow

on some intervals amount to double that quantity. It therefore becomes matter of prudent precaution to examine every interval previous to making the divisions; and, where necessary, to adjust the sector, so that its arc may exactly measure the corresponding interval as corrected by the tabulated errors.

it to return with the sector when the latter is set back at every course. Having in this manner proceeded, from one interval to another, through the whole circle, the micrometer at last will be found with its wire, at *zero*, on the dot from which it set out; and the sector, with its 16th division, coinciding with the wires of its microscope.

Having now given a faithful detail of every part of the process of dividing this circle, I wish to remind the reader that, by verification and correction at every interval, any erroneous action of the roller is prevented from extending its influence to any distant interval. It will be further observed, that the subdividing sector magnifies the work; that by means of its adjustable arc, it makes the run of the roller measure its corresponding intervals upon the circle; and, without foreign aid, furnishes the means of reducing the bisectional intervals to the usual division of the circle. Furthermore, the motion of the wire of the micrometer H, according to the divisions of its head and corresponding table of errors, furnishes the means of prosecuting the work with nearly the same certainty of success, as could have happened, had the 256 points been (which in practice is quite impossible) in their true places.

Now, the whole of my method of dividing being performed by taking short measures with instruments which cannot themselves err in any sensible degree, and, inasmuch as those measures are taken, not by the hand, but by vision, and the whole performed by only looking at the work, the eye must be charged with all the errors that are committed until we come to cut the divisions; and, as in this last operation the hand has no more to do than to guide an apparatus so perfect in itself, that it cannot be easily made to deviate from its proper course, I would wish to distinguish it from the other methods by denominating it, *dividing by the eye**.

The

* I must here remark, that Smeaton has represented the greatest degree of accuracy that can be derived from vision, in judging of the coincidence of two lines at $\frac{1}{7000}$ th part of an inch. From this it may fairly be inferred, that he had not cultivated the power of the sight, as he had done that of the touch; the latter of which, with that ability which appeared in all his works, he rendered sensible to the $\frac{1}{6000}$ th part of an inch. Were materials infinitely hard, no bounds could be set to the precision of contact; but taking things as they are, the different degrees of hardness in matter, may be considered as a kind of magnifying power to the touch, which may not unaptly be compared with the assistance which the eye receives from glasses. It is now quite common to divide the seaman's sextant to 10", and a good eye will estimate the half of it; which, on an eight-inch radius, is scarcely $\frac{1}{7000}$ th of an inch. This quantity, small as it is, is rendered visible by a glass of one inch focal length; and such is the certainty with which these quantities

The number of persons at all capable of dividing originally have hitherto been very few; the practice of it being so limited, that, in less than twice seven years, a man could hardly hope to become a workman in this most difficult art. How far I shall be considered as having surmounted these difficulties, I know not; but if, by the method here revealed, I have not rendered original dividing almost equally easy with what copying was before, I have spent much labour, time, and thought in vain. I have no doubt indeed, that any careful workman who can divide in common, and has the ability to construct an astronomical instrument, will, by following the steps here marked out, be able to divide it, the first time he tries, better than the most experienced workman, by any former method.

If, instead of subdividing with the roller, the same thing be performed with the screw, it will not give to dividing by the eye any very distinctive character: I have practised this on arcs of circles with success, the edge being slightly racked, the screw carrying forward an index with the requisite apparatus, and having a divided micrometer head; the latter answers to the subdividing sector, and, being used with a corresponding table of errors, forms the means of correcting the primitive points; but the roller furnishes a more delicate action, and is by far more satisfactory and expeditious.

It is known to many that the six-foot circle, which I am now at work upon for our Royal Observatory, is to be divided upon a broad edge, or upon a surface at right angles to the usual plane of division: the only alterations, which will on that account be required, are, that the roller must act upon that plane which is usually divided upon; which roller, being elevated or depressed, may be adjusted to the commensurate radius without being made conical, as was necessary in the other case. The apparatus, similar to the other, must here be fixed immoveable to the frame which

quantities are seen, that a seaman will sometimes complain that two pair of these lines will coincide at the same time; and that may happen, and yet no division of his instrument err, by more than $\frac{1}{20000}$ th part of an inch. All this is applicable to judging of the coincidence of lines with each other, and furnishes not the most favourable display of the accuracy of vision. But with the microscopes here described, where the wire bisects the image of a dot, or a cross wire is made to intersect the image of a line, by an eye practised in such matters, a coincidence may undoubtedly be ascertained to $\frac{1}{20000}$ th part of an inch. I am of opinion that as small a quantity may be rendered visible to the eye, as can by contact be made sensible to the touch; but whether Mr. Smeaton's $\frac{1}{20000}$ and my $\frac{1}{20000}$ be not the same thing, I will not determine; the difference between them, however, is what he would no more have pretended to feel, than I dare pretend to see.

supports

supports the circle; its position must be at the vertex, where also I must have my station; and the instrument itself must be turned around its axis, in its proper vertical position, as the work proceeds. The above may suffice, for the present, to gratify those who feel themselves interested upon a subject which will be better understood, if I should hereafter have the honour of laying before the Royal Society a particular description of the instrument here alluded to; a task which I mean to undertake, when, after being fixed in the place designed for it, which I hope will be effected at no very distant period, it shall be found completely to answer the purposes intended.

Should it be required to divide a circle according to the centesimal division of the quadrant, as now recommended and used in France, we shall have no difficulty. The 100° of the quadrant may be conveniently subdivided into 10 each, making 4000 divisions in the whole round. The 256 bisecting intervals, the two tables of errors, and the manner of proceeding and acting upon them, will be exactly the same as before, until we come to cut the divisions; and for this purpose we must have another line divided upon the sector. For $\frac{1}{4000}$ th part of the circle being equal to $5'4$ of the usual angular measure $\frac{1^\circ 24' 22'' \cdot 5}{5 \cdot 4} = 15\frac{1}{2}$ ths divisions; and just so many will be equivalent to one of the intervals of the circle. The value of one of the great divisions of the sector will be $1^\circ 26' 24''$, and that of the $\frac{1}{8}$ th parts, which are to be annexed to the right and left as before, will be $10' 48''$, therefore divisible by the engine. Should any astronomer choose to have both graduations upon his instrument, the additional cost would be a mere trifle, provided both were done at the same time.

It must already have been anticipated, that dividing by the eye is equally applicable to straight lines as it is to circles. An apparatus for this purpose should consist of a bar of brass, three quarters of an inch thick, and not less than three inches broad; six feet may do very well for the length; it may be laid upon a deal plank strengthened by another plank screwed edgewise on its lower surface. The bar should be planed, on both its edges and on its surface, with the greatest exactness; and it will be better, if it has a narrow slip of silver, inlaid through its whole length, for receiving the dots. An apparatus nearly similar to the other should slide along its surface, carrying a roller, whose circumference is 12.8 inches, and turned a little conical for the sake of adjustment. The roller may be divided into

32 parts, each of which when transferred to the bar will give intervals of 0.4 of an inch each: the angle of the subdividing sector should of course be $11^{\circ} 15'$, and subdivided into four parts, which will divide the inch into tenths: the surface may also receive other lines, with subdivisions suited to the different purposes for which it may be wanted. The revolutions of the roller and its $\frac{1}{2}$ parts must be dotted upon the bar; taking care, by sizing the roller, to come as near the true standard measure as possible: when this is done, compare the extent of the greater bisecting number that is contained in the length; *i. e.* 128 intervals of 51.2 inches, with the standard measure; noting the difference as indicated by the micrometer heads: the examination and construction of the table of errors may then be conducted just as was done for the circle.

Being now ready for the performance of its work, the scale to be divided must be laid alongside of the bar, and the true divisions must be cut upon it by an appeal, as before, to the erroneous dots on the bar, corrected by a corresponding table of errors. The apparatus, remaining entire in the possession of the workman, with its primitive dots, the table of errors, &c., is ready for dividing another standard, which will be precisely similar to others that have been, or may be, divided from it. It may be considered, indeed, as a kind of engine; and, as it is not vitiated by the coarse operation of racking with a screw, but performed by only looking at the work, the method will command about three times the accuracy that can be derived from the usual straight-line dividing engine. Should it be asked, if an engine thus appointed would succeed for dividing circles? I answer, Yes; but I would not recommend it; because, beyond a certain extent of radius, it is not necessary; for the errors, which would be introduced into the work by the violence of racking a large wheel, are sufficiently reduced by the comparative shortness of the radius of such instruments as we divide by that method: and, what is still more to the purpose, the dividing engine is four times more expeditious, and bears rough usage better. I cannot quit the subject of dividing straight lines without observing, that I never had my apparatus complete. The standard which I made for sir George Shuckburg Evelyn in 1796, was done by a mere make-shift contrivance, upon the principle of dividing by the eye; how I succeeded may be seen in Sir George's papers on Weights and Measures (Philosophical Transactions for 1798). I made a second, some years after, for professor Pictet of Geneva, which

which became the subject of comparison with the new measure of France, before the National Institute; and their report, drawn up by Mr. Pictet, has been ably re-stated and corrected by Dr. Young, as published in the Journals of the Royal Institution. I made a third for the magistrates of Aberdeen. I notice the two latter, principally to give myself an opportunity of saying that, if those three scales were to be compared together, notwithstanding they were divided at distant periods of time, and at different seasons of the year, they would be found to agree with each other, as nearly as the different parts of the same scale agree.

I hope I may here be allowed to allude to an inadvertency which has been committed in the paper mentioned above; and which sir George intended to have corrected, had he lived to conclude his useful endeavours to harmonize the discordant weights and measures of this country. The instruments which he has brought into comparison are, his own five-foot standard measure and equatorial; general Roy's forty-two inch scale; the standard of Mr. Aubert; and that of the Royal Society. The inadvertency is this: in his equatorial, and the standard of the Royal Society, he has charged the error of the most erroneous extent, when compared with the mean extent, alike to both divisions; *i. e.* he has supposed one of the divisions, which bound the erroneous extent, to be too much to the right, and the other too much to the left, and that by equal quantities. This is certainly a good-natured way of stating the errors of work; and perhaps not unjustly so, where the worst part has been selected; but in the other three instances, namely, in general Roy's, Mr. Aubert's, and his own standard, he has charged the whole error of the most erroneous extent to one of the bounding lines.

I was well confirmed in my high opinion of the general accuracy of Bird's dividing, when, last winter*, I measured the chords of many arcs of the Greenwich quadrant: that instrument has indeed suffered both from a change in its figure, and from the wearing of its centre; but the graduation, considering the time when it was done, I found to be very good. Sir George in his paper upon the Equatorial (Philosophical Transactions for 1793), after some compliments paid to the divider of his instrument, says, "The late Mr. John Bird seems to have admitted a probable discrepancy in the divisions of his eight-feet quadrant

* This paper was written in June 1808.

amounting to 3'';" and he refers to Bird on the construction of the Greenwich quadrant. This quantity being three times as great as any errors that I met with, I was lately induced to inquire how the matter stood. Bird, in the paper referred to, says, "In dividing this instrument I never met with an inequality that exceeded one second. I will suppose that in the 90 arch this error lay towards the left hand, and in the 96 arch that it lay towards the right, it will cause a difference between the two arches of two seconds; and if an error of one second be allowed to the observer in reading off his observation, the whole amount is no more than three seconds, which is agreeable to what I have heard, &c." Sir George's examination of his own equatorial furnishes me with the means of a direct comparison: in his account of the declination circle, we find an error + 2''·35, and another - 1''·5; to these add an error of half a second in each, for reading off, which Sir George also admits; we shall then have a discrepancy of 4''·85; but as the errors of reading off are not errors of division, let them be discharged from both, and the errors will then stand,—for the quadrant 2'', and for the circle 3''·85. As the radius of the former, however, is four times greater than that of the latter, it will appear, by this mode of trial, that the equatorial is rather more than twice as accurately divided as the quadrant. In doing justice to Bird in this instance, I have only done as I would be done by; for, should any future writer set me back a century on the chronological scale of progressive improvement, I hope some one will be found to restore me to my proper niche. I now subjoin a re-statement of the greatest error of each of the instruments that are brought into comparison by Sir George, after having reduced them all by one rule; viz. allowing each of the two points which bound the most erroneous extent to divide the apparent error equally between them. They are expressed in parts of an inch, and follow each other in the order of their accuracy.

Sir George Shuckburg's 5-foot standard	-	·000165
General Roy's scale of 42 inches	-	·000240
Sir George's equatorial, 2-foot radius	-	·000273
The Greenwich quadrant, 8 feet radius	-	·000465
Mr. Aubert's standard, 5 feet long	-	·000700
The Royal Society's standard, 92 inches long*	-	·000795

For the justness of the above statement I consider my name as pledged; requesting the permission to say, that if

* This is the same which Mr. Bird used in dividing his eight-foot mural quadrants, and was presented to the Royal Society by Bird's executors.

on the result of each respective examination, as here presented, there could have been more than one opinion, it would not have appeared here. I am further prompted to add, that the above comparative view presents one circumstance to our notice, which cannot do less than gratify every individual who is at all conversant in these matters; I mean, the high rank which general Roy's scale takes in the list; that scale having been made the agent in measuring the base line of our national trigonometrical survey.

To return, finally, to the dividing of circles; I must state, as matter of precaution, that great care should be taken during the turning of the outer edge, to have the circle of the same temperature; for one part may be expanded by heat, or contracted by cold, so much more than another, as to cause the numbers in the tables of errors to be inconveniently large. A night is not more than sufficient for allowing the whole to take the same temperature, after having been handled by the workmen; and the finishing touch should be given within a short space of time. But, if the effects of temperature are to be regarded in turning a circle, it is of tenfold more importance to attend to this circumstance, while the examination of the larger arcs of the instrument is carried on; for it is absolutely necessary that, during this time, the whole circle should be of the same heat exactly. Few workmen are sufficiently aware of this: they generally suppose the expansion of metals to be a trifle which need not be regarded in practice; and wonder how the parts of a circle can be differently heated without taking pains to make it so. One degree of Fahrenheit's thermometer indicates so small a portion of heat that, in such places as workmen are usually obliged to do their business in, it is not very easy to have three thermometers attached to different parts of a large instrument, showing an equality of temperature within that quantity: yet so necessary is correctness in this respect, that if a circle has the vertex one degree warmer than its opposite, and if this difference of temperature be regularly distributed from top to bottom, the upper semi-circle will actually exceed the lower by 2": and, if such should happen to be the case while the examination of the first dot of the third quadrant is made, the regularity of the whole operation would thereby be destroyed.

It may not be improper to remark, that dividing by the eye does not require a more expensive apparatus than the operation of dividing by hand; and, indeed, less so when the scale of inches is deemed necessary. The method by

adjustment is still more expensive, requiring whatever tools Bird's method requires, and, in addition to these, a frame and microscopes, somewhat similar to those for dividing by the eye.

It is somewhat more difficult to give a comparative estimate of the time which the different methods of dividing require. I know that thirteen days of eight hours each are well employed in dividing such a circle by my method; about fifty-two days would be consumed in doing the same thing by Bird's method; and I think I cannot err much when I state the method by adjustment, supposing every dot to be tried, and that two-thirds of them want adjusting, to require about one hundred and fifty of such days.

The œconomy of time (setting aside the decided means of accuracy) which the above estimate of its application offers to view, will, I think, be considered of no little moment. By the rising artist who may aspire at excellence, it will at least; and I should hope, with gratitude, be felt in the abbreviation of his labours. To me, indeed, the means of effecting this became indispensable; and it has not been without a sufficient sense of its necessity, that I have been urged to the progressive improvement and completion of these means, as now described. It is but little that a man can perform with his own hands alone; nor is it on all occasions, even in frames of firmer texture than my own, that he can decisively command their adequate, unerring, use. And I must confess that I never could reconcile it to what I hold as due to myself, as well as to a solicitous regard for the most accurate cultivation of the science of astronomy, to commit to others an operation requiring such various and delicate attentions, as the division of my instruments.

That my attentions on this head have not failed to procure for me the notice and patronage of men whose approbation makes, with me, no inconsiderable part of my reward, I have to reflect on with gratitude and pleasure: and as I look with confidence to the continuance of that patronage so long as the powers of execution shall give me the inclination to solicit it, I cannot entertain a motive which might go to extinguish the more liberal wish of pointing out to future ingenuity a shorter road to eminence; sufficiently gratified by the idea of having, in the present communication, contributed to facilitate the operations, and to aid the progress of art (as far as the limited powers of vision will admit) towards the point of perfection.

Table of apparent Errors.

Name of the Lot.	First Quadrant.	Second Quadrant.	Third Quadrant.	Fourth Quadrant.	First Quadrant.	Second Quadrant.	Third Quadrant.	Fourth Quadrant.	Name of the Dot.
0°	0	+ 12.2	- 6.9	+ 17.9	+ 4.6	+ 17.1	- 4.4	+ 17.3	1.4
45.0	- 21.9	- 8.9	16.7	- 29.6	- 5.2	- 9.7	8.9	- 6.4	4.2
22.5	1.6	2.2	1.0	2.7	0.0	3.8	1.0	4.7	7.0
67.5	+ 1.0	+ 15.6	0.0	+ 13.7	+ 1.0	+ 3.5	5.1	5.5	9.8
11.2	- 16.6	- 20.2	22.6	- 30.3	- 5.5	- 1.6	0.0	+ 1.2	12.7
53.7	4.0	4.2	13.2	23.1	7.6	7.6	4.2	- 2.3	15.5
56.2	16.9	22.2	17.0	22.7	9.1	3.9	0.0	5.3	18.3
78.7	30.8	16.6	31.3	30.3	+ 1.1	+ 12.1	+ 4.2	+ 4.3	21.1
5.6	2.7	8.6	4.1	10.1	12.3	0.9	6.2	14.4	23.9
16.9	11.5	11.3	11.2	16.1	- 5.7	- 6.2	1.1	- 11.2	26.7
28.1	9.0	7.4	5.8	14.3	+ 1.5	3.5	- 6.3	4.2	29.5
39.4	9.3	8.2	5.8	13.1	0.0	7.0	7.7	+ 1.4	32.3
50.6	4.2	6.6	8.2	4.4	1.5	+ 9.0	+ 3.0	4.3	35.2
61.9	4.3	8.4	12.5	4.4	- 8.6	- 5.9	- 2.0	- 6.7	38.0
73.1	7.6	10.0	13.6	9.7	3.3	+ 2.7	4.9	1.5	40.8
84.4	18.0	+ 6.0	16.3	7.1	+ 4.0	3.1	3.5	+ 1.0	43.6
2.8	3.4	- 7.5	8.9	2.1	13.5	10.5	+ 16.0	14.9	46.4
8.4	0.0	5.0	4.6	5.7	2.1	0.0	1.7	- 3.5	49.2
14.1	6.6	8.2	5.6	4.8	- 5.0	- 10.7	- 2.9	1.5	52.0
19.7	1.6	2.4	+ 1.0	2.5	4.2	7.9	2.2	7.2	54.8
25.3	3.7	8.2	- 2.9	2.5	4.0	3.0	2.5	1.0	57.7
30.9	+ 2.4	7.1	7.0	0.0	7.3	+ 6.2	6.1	1.5	60.5
36.6	- 5.9	+ 1.0	2.5	1.5	3.2	- 10.1	5.6	12.7	63.6
42.2	+ 3.1	1.9	5.8	+ 2.5	1.4	7.2	3.9	+ 2.2	66.1
47.8	7.1	5.2	+ 2.4	4.8	+ 11.2	+ 14.9	+ 21.2	7.2	68.9
53.4	- 5.6	- 6.0	- 5.0	- 6.1	- 7.1	- 1.0	- 8.9	- 11.7	71.1
59.1	10.7	+ 1.0	3.0	+ 1.4	5.3	1.2	6.6	2.7	74.5
64.7	7.9	- 18.0	10.7	- 9.0	7.2	9.9	+ 1.0	5.9	77.3
70.3	2.7	7.4	1.5	9.0	6.5	1.8	5.3	2.6	80.2
75.9	1.2	5.2	2.2	4.7	+ 4.4	+ 1.4	- 2.2	4.3	83.0
81.6	1.6	+ 1.7	0.0	2.0	- 20.8	- 0.0	11.4	+ 1.0	85.8
87.2	13.7	6.0	3.5	+ 5.6	+ 2.1	+ 11.0	4.0	9.5	88.6

Table of real Errors.

Name of the Dot.	First Quadrant.	Second Quadrant.	Third Quadrant.	Fourth Quadrant.	First Quadrant.	Second Quadrant.	Third Quadrant.	Fourth Quadrant.	Name of the Dot.
0.0	0.0	+ 8.8	- 6.9	+ 14.4	- 16.9	- 8.0	- 13.4	- 22.4	45.0
1.4	- 4.8	- 0.6	16.0	5.9	8.7	5.5	9.7	16.1	46.4
2.8	10.2	9.3	24.0	- 2.9	14.3	9.6	17.4	22.3	47.8
4.2	15.8	15.1	28.3	12.8	22.3	17.9	19.9	33.8	49.2
5.6	13.7	12.5	23.3	16.1	26.0	21.6	26.7	31.9	50.6
7.0	15.9	16.8	28.7	19.4	25.5	26.0	23.6	28.9	52.0
8.4	17.6	19.6	32.0	27.0	32.0	27.8	30.3	38.3	53.4
9.8	21.4	16.1	35.5	30.7	34.0	27.3	29.1	35.2	54.8
11.2	21.6	16.7	31.5	26.5	26.8	22.1	24.0	32.6	56.2
12.7	27.9	21.6	32.2	23.6	29.6	24.5	29.7	29.8	57.7
14.1	31.1	26.8	37.5	34.4	33.7	17.7	27.2	24.6	59.1
15.5	28.5	22.7	30.2	26.8	30.2	15.6	29.3	26.5	60.5
16.9	27.3	20.5	32.4	32.7	19.2	15.3	24.1	19.4	61.9
18.3	29.0	18.2	24.2	25.7	21.5	14.6	18.3	23.7	63.3
19.7	20.2	13.5	20.6	22.2	19.0	21.5	22.4	17.4	64.7
21.1	22.4	5.9	22.1	24.0	18.8	19.9	22.8	17.1	66.1
22.5	10.0	1.8	10.9	6.7	3.0	+ 8.2	+ 0.7	+ 2.5	67.5
23.9	8.8	12.2	16.0	14.9	9.8	- 2.8	- 2.5	- 13.0	68.9
25.3	19.8	15.5	20.2	24.0	15.7	10.2	18.7	19.2	70.3
26.7	21.7	16.1	20.0	33.0	21.9	7.0	21.8	25.8	71.7
28.1	22.1	12.8	23.8	36.4	23.0	13.9	25.1	23.0	73.1
29.5	17.1	15.8	28.9	35.0	27.1	14.3	25.3	26.8	74.5
30.9	22.1	18.0	31.4	37.0	26.6	20.1	26.6	30.7	75.9
32.3	24.7	19.3	33.3	37.7	33.3	21.1	22.7	31.1	77.3
33.7	17.4	9.1	25.1	37.6	27.9	16.0	23.8	29.1	78.7
35.2	22.7	8.0	25.1	35.7	35.5	14.5	18.5	28.7	80.2
36.6	27.3	11.9	27.4	41.8	29.3	9.0	22.4	27.2	81.6
38.0	26.5	15.6	26.9	40.6	21.0	6.6	17.5	21.4	83.0
39.4	26.4	16.7	24.8	43.1	27.5	5.4	21.0	21.6	84.4
40.8	25.4	7.2	25.1	33.6	31.0	7.9	15.4	12.6	85.8
42.2	18.5	10.4	24.7	30.2	23.0	0.1	6.8	5.2	87.1
43.6	16.3	10.0	24.6	31.7	16.3	3.7	15.9	6.4	88.5
45.0	16.9	8.0	13.0	1.4	+ 8.3	6.9	+ 14.4	0.0	90.0

XXV. *Report made to the Institute on two Memoirs of M. GRATIEN LEPERE, Engineer of the Imperial Roads and Bridges, on natural and artificial Puzzolano. By M. CHAPTAL**.

EVERY person is acquainted with the purposes to which puzzolano is applied in buildings under water. The property possessed by this volcanic substance of speedily becoming hard when mixed with sour lime, in the composition of cements for hydraulic purposes, has rendered it a most important article; but the difficulty of procuring it from Italy while the navigation of the seas is interrupted, has made it extremely scarce and dear. Attempts have therefore frequently been made to procure a substitute for puzzolano, in substances which are to be procured in all countries and at a low price.

It seems, therefore, an interesting subject to collect the various processes which have been employed for adapting different mineral substances to the uses of puzzolano, and with this view I have drawn up the present extract of M. Lepere's two memoirs, without binding myself to follow his order.

A substitute for puzzolano may be procured in three ways. 1st, By employing the remains of the extinguished volcanoes which almost all countries produce. 2dly, By substituting some other volcanic products for puzzolano. 3dly, By giving to certain mineral substances, by calcination, all the properties of these volcanic productions.

Messrs. Desmarests and Faujas St. Fond long ago made known some strata of good puzzolano in the volcanoes of Auvergne and Vivarais. I also pointed out this substance in the volcanoes which separate Lodeve from Bedarieux, in the department of the Herault, and it has been employed with success in the construction of bridges and other hydraulic buildings.

We may also find a substitute for puzzolano in other volcanic products, such as basalt, pumice stones carefully pounded, &c.

In 1787 M. Guyton de Morveau sent to M. de Cessart, at Cherbourg, some calcined basalts from the extinguished volcano of Drevin, in the department of the Var and Loire. The latter proved by conclusive experiments, that they might be employed with great advantage in buildings under water.

The Dutch terrass is a kind of pumice stone brought

* From *Annales de Chimie*, tome lxiv. p. 273.

from Bonn and Andernach. At Dordrecht, at the mouths of the Rhine and Meuse, the operation of pounding is effected.

But these resources are local; and as the manufacture of puzzolano may become general, we proceed to describe the best means of attaining it.

It would be difficult to assign the period at which pounded bricks and the earthy residue from the distillation of aquafortis were substituted for volcanic puzzolano. Their use, however, has become general, particularly where there are no sea-ports in the vicinity at which real puzzolano can be furnished: even in the South of France they prefer the earthy residue of the distillation of aquafortis to the best puzzolanos for coating the inside of the wine tubs, which are almost all of mason work, and for the cements used by individuals in hydraulic works. The earth employed in the South of France for the decomposition of saltpetre, by extracting the aquafortis from it, is an ochrey earth very much charged with iron, and more or less reddened by the oxide of this metal. When it is wanted for cement, it is only necessary to beat it up with lime and a proper quantity of water. M. Lepere relates some experiments made at Paris by the engineers of roads and bridges, from which it appears that an immersion of eight days was sufficient for aquafortis cements to acquire a hardness fit to resist a billet of wood when forced against it with the whole strength of a man; whereas the Italian puzzolano required six weeks before it attained the same degree of hardness.

In general the quality of the earth is better in proportion as it is charged with iron.

This last observation is equally applicable to pounded bricks: in general they do not make a good cement unless they are well burnt, and made of very ferruginous earth.

Twenty years ago I suggested the above substitutes for puzzolano; and the result of my comparative trials made in the port of Cette, under the inspection of the engineers of the province of Languedoc, was published in 1787, in a memoir printed by Didot, by order of the states-general of the province.

The means which I suggested for making this artificial puzzolano are simple, and may be put in practice almost every where. Balls should be made of the ochrey earth, and burned in a lime or potter's kiln. In order to form these balls, the earth must be moistened with a sufficient quantity of water; and when the balls are made, they should be burned until they pass from a red to a black colour, and

the angles of the scales formed when they are broken exhibit sharp and shining edges.

In the same work I proposed to substitute the blackish schists which are decomposed in the air for puzzolanos. Those which are in cakes are best; but in all cases they must be strongly calcined, in order to give them the requisite properties.

M. Lepere relates that M. Vitalis, professor of chemistry and secretary to the Rouen Academy, and M. Lamassen, chief engineer of the department of the Lower Seine, have made most excellent puzzolano by the calcination of some ochrey earths in the environs of Rouen: this was effected by burning the earth in a common furnace with alternate strata of common charcoal. This puzzolano was subjected to some trials on a large scale, and it was composed in the following manner:

One part and a half of yellow calcined ochrey earth.

One part and three-fourths of well washed siliceous sand.

One part and an eighth of sour lime.

Two parts of chips from calcareous stone and silex.

From these and several other experiments (the proportions of which were varied) it results, that the artificial puzzolano constantly exhibited the same effects as the best puzzolano of Italy. M. Lepere was an eye-witness of all these comparative experiments.

There can be no doubt, therefore, that wherever there are ochrey earths, artificial puzzolano may be made with great facility.

What is called Dutch terrass is in many respects similar to the artificial puzzolano in question.

The ashes, or rather scorixæ, left when coals are burnt, may also be applied to the same purpose. M. Guyton caused a trial to be made at Cherbourg, and it succeeded well.

M. Gratien Lepere, having been intrusted in 1804 with constructing the foundation of the new arsenal at Cherbourg, began to turn his attention to the best method of supplying the puzzolano of Italy. He knew that the Swedes had already used a very hard black slate with this view, after being twice strongly calcined in a lime-kiln.

M. Lepere thought he perceived a great analogy between the Swedish stone and the rocks of Cherbourg, particularly those of port Bonaparte, which, when dug into, exhibited a black schistus, hard, ferruginous, and falling off in scales

of various thickness: subsequent experiments, however, proved that the slaty schistus of Roule, in the environs of Cherbourg, is preferable, and that good mortar may be made with the ferruginous schist of Haineville, which is inferior, however, to the two former.

After having multiplied and varied his experiments in such a manner as to present positive results, M. Lepere, in conjunction with the committee of engineers appointed to examine his experiments, draws the following conclusions:

1st. That the schist of Cherbourg, when strongly calcined and pulverised, forms an excellent mortar when mixed with sour lime.

2dly. That in order to give precisely the same properties to schist which are possessed by puzzolano and terrass, the former must be calcined in a reverberating, instead of a lime, furnace.

XXVI. *The Bakerian Lecture. An Account of some new analytical Researches on the Nature of certain Bodies, particularly the Alkalies, Phosphorus, Sulphur, Carbonaceous Matter, and the Acids hitherto undecomposed; with some general Observations on Chemical Theory.* By HUMPHRY DAVY, Esq., Sec. R.S., F.R.S. Edin., and M.R.I.A.

[Concluded from p. 124.]

VIII. *Analytical Experiments on Muriatic Acid.*

I HAVE made a greater number of experiments upon this substance, than upon any of the other subjects of research that have been mentioned; it will be impossible to give any more than a general view of them within the limits of the Bakerian lecture.

Researches carried on some years ago, and which are detailed in the Journals of the Royal Institution, showed that there were little hopes of decomposing muriatic acid, in its common form, by Voltaic electricity. When aqueous solution of muriatic acid is acted upon, the water alone is decomposed; and the Voltaic electrization of the gas affords no indications of its decomposition; and merely seems to show, that this elastic fluid contains much more water than has been usually suspected.

I have already laid before the Society, an account of some experiments made on the action of potassium on muriatic

acid. I have since carried on the same processes on a larger scale, but with precisely similar results.

When potassium is introduced into muriatic acid gas, procured from muriate of ammonia and concentrated sulphuric acid, and freed from as much moisture as muriate of lime is capable of attracting from it, it immediately becomes covered with a white crust, it heats spontaneously, and by the assistance of a lamp, acquires in some parts the temperature of ignition, but does not inflame. When the potassium and the gas are in proper proportions, they both entirely disappear; a white salt is formed, and a quantity of pure hydrogen gas evolved, which equals about one-third of the original volume of the gas.

By eight grains of potassium employed in this way, I effected the absorption of nearly twenty-two cubical inches of muriatic acid gas; and the quantity of hydrogen gas produced was equal to more than eight cubical inches.

The correspondence between the quantity of hydrogen generated in cases of this kind, and by the action of potassium upon water, combined with the effects of ignited charcoal upon muriatic acid gas, by which a quantity of inflammable gas is produced equal to more than one-third of its volume, seemed to show, that the phenomena merely depended upon moisture combined with the muriatic acid gas*.

To determine this point with more certainty however, and to ascertain whether or no the appearance of the hydrogen was wholly unconnected with the decomposition of the acid, I made two comparative experiments on the quantity of muriate of silver, furnished by two equal quantities of muriatic acid, one of which had been converted into muriate of potash by the action of potassium, and the other of which had been absorbed by water; every care was taken to avoid sources of error; and it was found that there was no notable difference in the weight of the results.

There was no proof then, that the muriatic acid had been decomposed in these experiments; and there was every reason to consider it as containing in its common aëriiform state, at least one-third of its weight of water; and this

* When the Voltaic spark is taken continuously, by means of points of charcoal in muriatic acid gas over mercury, muriate of mercury is rapidly formed, a volume of inflammable gas, equal to one-third of the original volume of the muriatic acid gas, appears. The acid gas enters into combination with the oxide of mercury, so that water enough is present in the experiment to form oxide sufficient to absorb the whole of the acid.

conclusion

conclusion we shall find warranted by facts, which are immediately to follow.

I now made a number of experiments, with the hopes of obtaining the muriatic acid free from water.

I first heated to whiteness, in a well luted porcelain retort, a mixture of dry sulphate of iron, and muriate of lime which had been previously ignited; but a few cubic inches of gas only were obtained, though the mixture was in the quantity of several ounces; and this gas contained sulphureous acid. I heated dry muriate of lime, mixed both with phosphoric glass and dry boracic acid, in tubes of porcelain, and of iron, and employed the blast of an excellent forge; but by neither of these methods was any gas obtained, though when a little moisture was added to the mixtures, muriatic acid was developed in such quantities, as almost to produce explosions.

The fuming muriate of tin, *the liquor of Libavius*, is known to contain dry muriatic acid. I attempted to separate the acid from this substance, by distilling it with sulphur and with phosphorus; but without success. I obtained only triple compounds, in physical characters, something like the solutions of phosphorus, and sulphur in oil, which were non-conductors of electricity, which did not redden dry litmus paper, and which evolved muriatic acid gas with great violence, heat, and ebullition on the contact of water.

I distilled mixtures of corrosive sublimate and sulphur, and of calomel and sulphur; when these were used in their common states, muriatic acid gas was evolved; but when they were dried by a gentle heat, the quantity was exceedingly diminished, and the little gas that was generated gave hydrogen by the action of potassium. During the distillation of corrosive sublimate and sulphur, a very small quantity of a limpid fluid passed over. When examined by transmitted light, it appeared yellowish green. It emitted fumes of muriatic acid, did not redden dry litmus paper, and deposited sulphur by the action of water. I am inclined to consider it as a modification of the substance discovered by Dr. Thomson, in his experiments on the action of oxymuriatic acid on sulphur.

MM. Gay Lussac and Thenard* have mentioned, that they endeavoured to procure dry muriatic acid by distilling a mixture of calomel and phosphorus, and that they obtained a fluid which they consider as a compound of mu-

* The *Moniteur* before quoted.

riatic acid, phosphorus, and oxygen. In distilling corrosive sublimate with phosphorus, I had a similar result, and I obtained the substance in much larger quantities, than by the distillation of phosphorus with calomel.

As oxymuriatic acid is slightly soluble in water, there was reason to suppose, reciprocally that water must be slightly soluble in this gas; I endeavoured therefore to procure dry muriatic acid, by absorbing the oxygen from oxymuriatic acid gas by substances, which when oxygenated produce compounds possessing a strong affinity for water. Phosphorus, it is well known, burns in oxymuriatic acid gas; though the results of this combustion, I believe, have never been minutely examined. With the hopes of procuring muriatic acid gas, free from moisture, I made the experiment. I introduced phosphorus into a receiver having a stop-cock, which had been exhausted, and admitted oxymuriatic acid gas. As soon as the retort was full, the phosphorus entered into combustion, throwing forth pale white flames. A white sublimate collected in the top of the retort, and a fluid as limpid as water, trickled down the sides of the neck. The gas seemed to be entirely absorbed, for when the stop-cock was opened, a fresh quantity of oxymuriatic acid, nearly as much as would have filled the retort, entered.

The same phenomenon of inflammation again took place, with similar results. Oxymuriatic acid gas was admitted till the whole of the phosphorus was consumed.

Minute experiments proved, that no gaseous muriatic acid had been evolved in this operation, and the muriatic acid was consequently to be looked for either in the white sublimate; or in the fluid which had formed in the neck of the retort.

The sublimate was in large portions, the fluid only in the quantity of a few drops. I collected by different processes, sufficient of both for examination.

The sublimate emitted fumes of muriatic acid when exposed to air. When brought in contact with water, it evolved muriatic acid gas, and left phosphoric acid, and muriatic acid, dissolved in the water. It was a non-conductor of electricity, and did not burn when heated; but sublimed when its temperature was about that of boiling water, leaving not the slightest residuum. I am inclined to regard it as a combination of phosphoric and muriatic acid in their dry states.

The fluid was of a pale greenish yellow tint, and very limpid; when exposed to air, it rapidly disappeared, emitting

zing dense white fumes which had a strong smell differing a little from that of muriatic acid.

It reddened litmus paper in its common state, but had no effect upon litmus paper which had been well dried, and which was immediately dipped into it. It was a non-conductor of electricity. It heated when mixed with water, and evolved muriatic acid gas. I consider it as a compound of phosphorous acid, and muriatic acid, both free from water*.

Having failed in obtaining uncombined muriatic acid in this way, I performed a similar process with sulphur, but I was unable to cause it to inflame in oxymuriatic acid gas. When it was heated in it, it produced an orange-coloured liquid, and yellow fumes passed into the neck of the retort, which condensed into a greenish-yellow fluid. By repeatedly passing oxymuriatic acid through this fluid, and distilling it several times in the gas, I rendered it of a bright olive-colour, and in this case it seemed to be a compound of dry sulphuric and muriatic acid, holding in solution a very little sulphur. When it was heated in contact with sulphur, it rapidly dissolved it, and then became of a bright red colour, and when saturated with sulphur, of a pale golden colour†. No permanent æriform fluid was evolved in any of these operations, and no muriatic gas appeared, unless moisture was introduced.

As there seemed little chance of procuring uncombined muriatic acid, it was desirable to ascertain what would be the effects of potassium upon it in these singular compounds.

When potassium was introduced into the fluid, generated by the action of phosphorus on corrosive sublimate, at first it slightly effervesced, from the action of the liquid on the moist crust of potash surrounding it; but the metal soon appeared perfectly splendid, and swimming on the surface. I attempted to fuse it by heating the fluid, but it entered into ebullition at a temperature below that of the fusion of the potassium; indeed the mere heat of the hand was sufficient for the effect. On examining the potassium, I found

* I attempted to obtain dry muriatic acid likewise from the phosphuretted muriatic acid of MM. Gay Lussac and Thenard, by distilling it in retorts containing oxygen gas, and oxymuriatic acid gas. In the first case, the retort was shattered by the combustion of the phosphorus, with a violent explosion. In the second, compounds, similar to those described above, were formed.

† All these substances seem to be of the same nature as the singular compound, the sulphuretted muriatic acid, discovered by Dr. Thomson, noticed before.

that it was combined at the surface with phosphorus, and gave phosphuretted hydrogen by its operation upon water.

I endeavoured, by repeatedly distilling the fluid from potassium in a close vessel, to free it from phosphorus, and in this way I succeeded in depriving it of a considerable quantity of this substance.

I introduced ten or twelve drops of the liquid, which had been thus treated, into a small plate glass retort, containing six grains of potassium; the retort was exhausted after having been twice filled with hydrogen, the liquid was made to boil, and the retort kept warm till the whole had disappeared as elastic vapour. The potassium was then heated by the point of a spirit lamp; it had scarcely melted, when it burst into a most brilliant flame, as splendid as that of phosphorus in oxygen gas, and the retort was destroyed by the rapidity of combustion.

In other trials made upon smaller quantities after various failures, I was at last able to obtain the results; there was no proof of the evolution of any permanent elastic fluid during the operation. A solid mass remained of a greenish colour at the surface, but dark gray in the interior. It was extremely inflammable, and often burnt spontaneously when exposed to air; when thrown upon water, it produced a violent explosion, with a smell like that of phosphuretted hydrogen. In the residuum of its combustion there was found muriate of potash, and phosphate of potash.

I endeavoured to perform this experiment in an iron tube, hoping that if the muriatic acid was decomposed in the process, its inflammable element, potassium and phosphorus, might be separated from each other by a high degree of heat; but in the first part of the operation the action was so intense, as to produce a destruction of the apparatus, and the stop-cock was separated from the tube with a loud detonation.

I heated potassium in the vapour of the compound of muriatic and phosphoric acid; but in this case the inflammation was still more intense, and in all the experiments that I have hitherto tried, the glass vessels have been either fused or broken; the solid residuum has however appeared to be of the same kind as that I have just described.

The results of the operation of the sulphuretted compounds containing muriatic acid free from water upon potassium, are still more extraordinary than those of the phosphuretted compounds.

When a piece of potassium is introduced into the substance that distils over during the action of heated sulphur upon

upon oxymuriatic acid, it at first produces a slight effervescence, and if the volume of the potassium considerably exceeds that of the liquid, it soon explodes with a violent report, and a most intense light.

I have endeavoured to collect the results of this operation, by causing the explosion to take place in large exhausted plate glass retorts; but, except in a case in which I used only about a quarter of a grain, I never succeeded. Generally the retort, though connected with the air pump at the time, was broken into atoms; and the explosion produced by a grain of potassium, and an equal quantity of the fluid, has appeared to me considerably louder than that of a musket.

In the case in which I succeeded in exploding a quarter of a grain, it was not possible for me to ascertain if any gaseous matter was evolved; but a solid compound was formed of a very deep gray tint, which burnt, throwing off bright scintillations, when gently heated, which inflamed when touched with water, and gave most brilliant sparks, like those thrown off by iron in oxygen gas.

Its properties certainly differed from those of any compound of sulphur and potassium that I have seen: whether it contains the muriatic basis must however be still a matter of inquiry.

There is, however, much reason for supposing, that in the singular phænomena of inflammation and detonation that have been described, the muriatic acid cannot be entirely passive: and it does not seem unfair to infer, that the transfer of its oxygen and the production of a novel substance, are connected with such effects, and that the highly inflammable nature of the new compounds, partly depends upon this circumstance. I am still pursuing the inquiry, and I shall not fail immediately to communicate to the Society, such results as may appear to me worthy of their attention.

IX. *Some general Observations, with Experiments.*

An experiment has been lately published, which appeared so immediately connected with the discussion entered into in the second section of this Paper, that I repeated it with much earnestness.

In Mr. Nicholson's Journal for December, Dr. Woodhouse has given an account of a process, in which the action of water caused the inflammation of a mixture of four parts of charcoal and one of the pearlsh that had been
strongly

strongly ignited together, and the emission of ammonia from them. I thought it possible, that in this case a substance might be formed similar to the residuum described in page 487 (*Philosophical Magazine*, vol. xxxiii.); but by cooling the mixture out of the contact of nitrogen, I found that no ammonia was formed; and this substance evidently owed its existence to the absorption of atmospherical air by the charcoal*.

The experiments that I have detailed on the acids, offer some new views with respect to the nature of acidity. That a compound of muriatic acid with oxide of tin or phosphorus should redden vegetable blues, might be ascribed to a species of neutralization, by the oxide or inflammable body; but the same reasoning will not apply to the dry compounds which contain acid matter only, and which are precisely similar as to this quality. Let a piece of dry and warm litmus paper be moistened with the compound of muriatic and phosphorous acid, it perfectly retains its colour. Let it then be placed upon a piece of moistened litmus paper, it instantly becomes of a bright red, heats and develops muriatic acid gas.

All the fluid acids that contain water are excellent conductors of electricity, in the class called that of imperfect conductors; but the compounds to which I have just alluded, are non-conductors in the same degree as oils, with which they are perfectly miscible. When I first examined muriatic acid, in its combinations free from moisture, I had great hopes of decomposing them by electricity; but there was no action without contact of the wires, and the spark seemed to separate no one of their constituents, but only to render them gaseous. The circumstance likewise applies to the boracic acid, which is a good conductor as long as it contains water; but which, when freed from water and made fluid by heat, is then a non-conductor.

* Potash or pearlash is easily decomposed by the combined attractions of charcoal and iron; but it is not decomposable by charcoal, or, when perfectly dry, by iron alone. Two combustible bodies seem to be required by their combined affinities for the effect; thus in the experiment with the gun barrel, iron and hydrogen are concerned. I consider Homberg's pyrophorus as a triple compound of potassium, sulphur, and charcoal; and in this ancient process, the potash is probably decomposed by two affinities. The substance is perfectly imitated by heating together ten parts of charcoal, two of potassium, and one of sulphur.

When I first showed the production of potassium to Dr. Wollaston in October 1807, he stated, that this new fact induced him to conceive that the action of potash upon platina, was owing to the formation of potassium, and proposed it, as a matter of research, whether the alkali might not be decomposed by the joint action of platina and charcoal.

The alkalis and the earthy compounds, and the oxides, as dry as we can obtain them, though non-conductors when solid, are, on the contrary, all conductors when rendered fluid by heat.

When muriatic acid, existing in combination with phosphorus or phosphoric acid, is rendered gaseous by the action of water, the quantity of this fluid that disappears, at least equals from one-third to two-fifths of the weight of the acid gas produced; a circumstance that agrees with the indications given by the action of potassium.

I attempted to procure a compound of dry muriatic and carbonic acids, hoping that it might be gaseous, and that the two acids might be decomposable at the same time by potassium. The process that I employed was by passing corrosive sublimate in vapour through charcoal ignited to whiteness; but I obtained a very small quantity of gas, which seemed to be a mixture of common muriatic acid gas and carbonic acid gas; a very minute portion of running mercury only was obtained, by a long continuation of the process; and the slight decomposition that did take place, I am inclined to attribute to the production of water, by the action of the hydrogen of the charcoal upon the oxygen of the oxide of mercury*.

In mixing muriatic acid gas with carbonic acid, or oxygen, or hydrogen, the gases being in their common states, as to moisture, there was always a cloudiness produced; doubtless owing to the attraction of their water to form liquid muriatic acid.

On fluoric acid gas no such effect was occasioned. This fact, at first view, might be supposed to show, that the hydrogen evolved by the action of potassium upon fluoric acid gas, is owing to water in actual combination with it, like that in muriatic acid gas, and which may be essential to its elastic state; but it is more probable, from the smallness of the quantity, and from the difference of the quantity in different cases, that the moisture is merely in that state of diffusion or solution in which it exists in gases in general, though from the disposition of water to be deposited in this acid gas in the form of an acid solution, it must be either less in quantity, or in a less free state, so

* These facts and the other facts of the same kind, explain the difficulty of the decomposition of the metallic muriates in common processes of metallurgy. They likewise explain other phenomena in the agencies of muriatic salts. In all cases when a muriatic salt is decomposed by an acid, and muriatic acid gas set free, there appears to be a double affinity, that of the acid for the basis, and of the muriatic acid for water; pure muriatic acid does not seem capable of being displaced by any other acid.

as to require for its exhibition much more delicate hygrometrical tests.

The facts advanced in this lecture, afford no new arguments in favour of an idea to which I referred in my last communication to the Society, that of hydrogen being a common principle in all inflammable bodies; and except in instances which are still under investigation, and concerning which no precise conclusions can as yet be drawn, the generalization of Lavoisier happily applies to the explanation of all the new phenomena.

In proportion as progress is made towards the knowledge of pure combustible bases, so in proportion is the number of metallic substances increased; and it is probable that sulphur and phosphorus, could they be perfectly deprived of oxygen, would belong to this class of bodies. Possibly their pure elementary matter may be procured by distillation, at a high heat, from metallic alloys, in which they have been acted upon by sodium or potassium. I hope soon to be able to try this experiment.

As our inquiries at present stand, the great general division of natural bodies is into matter which is, or may be supposed to be, metallic, and oxygen; but till the problem concerning the nature of nitrogen is fully solved, all systematic arrangements made upon this idea must be regarded as premature.

Explanation of the Figures.

Fig. 1. The retort of plate glass for heating potassium in gases.

Fig. 2. The tray of platina for receiving the potassium.

Fig. 3. The platina tube for receiving the tray in experiments of distillation.

Fig. 4. The apparatus for taking the Voltaic spark in sulphur and phosphorus.

XXVII. *On the Causes which have operated in the Production of Valleys.* By JOHN CARB, Esq., of Manchester.
—No. III.

To Mr. Tilloch.

SIR, IT was not my intention to have intruded again into your very respectable journal, wherein, indeed, I first incidentally appeared, solely with a view of showing, in opposition to some hypothetical notions, that *moving water* has been, and yet continues to be, the great and general agent
of

of mobility of all the loose materials of our earth; and that instead of wandering out of Nature after hypothetical ænigmas, to explain the mighty changes which the exterior and interior of our globe have every where undergone, we have only to appreciate, justly, the incessant, varied, and powerful action of that fluid, in order to obtain the most rational, simple, and natural elucidation of all the general and principal phænomena in geology. That branch of the subject, however, which relates to the action of fresh water streams flowing over unequal and inclined surfaces having experienced direct and decided opposition, I must again solicit the use of a few pages in your valuable repository.

The objections, indeed, to which I allude, are hardly entitled to any reply; for they in no respect invalidate, and scarcely at all advert to, the general question on its own broad basis, or meet the vast chain of general and harmonizing facts, upon which the whole merits of the case hinge.

These were expressly stated to be:—the elevated situation of the sources and springheads of all streams, which gives them an easy and natural flow over the countries out of which all valleys have been excavated,—the most important and material fact in the whole question;—the present slopes at the lower ends of most valleys, where the streams must originally have had a fall corresponding with the present depths of the valleys;—the mechanically abrading forces of the streams at these falls, and which are amply sufficient, with the occasional aid of flooded torrents, to have effected the excavation of the valleys;—the obvious certainty that, were the valleys again filled up, the streams would still continue to flow in nearly their present directions, forming in that case a succession of lakes and waterfalls, similar to what must have existed before the valleys were excavated;—that at the falls, produced by the filling up of the valleys, the streams would immediately commence the excavation of other valleys, in all respects similar to those of our present ones; and, in fine, that the streams themselves are the only agents in nature that can possibly have accomplished such a system of uniform effects as excavated valleys display throughout every country.

It was added, that all the existing phænomena, in the present courses of streams, strictly correspond with the foregoing order of things:—namely, the present direction of valleys, which every where so regularly falls in with the natural descent of the country, precisely as the streams must originally have done before the valleys were excavated, and would do again were they again filled up;—the unbroken chain

chain of alluvia which, *maugre* Mr. Farey's denial, does now actually accompany the course of every stream from its source to its termination, and which constantly corresponds with the strata traversed by the streams;—the innumerable intersections of valleys at the confluence of streams, in angles governed strictly by the general fall of the country, and the uniform levels on which these frequent intersections of valleys and streams meet;—evinced with all the precision of mathematical demonstration, that such a multitudinous unison of effects over the whole surface of the globe cannot possibly be referred to any other natural cause than the simple, obvious, and necessary operation of the streams themselves.

These were the clear, precise, and definite data on which I rested the proof of the streams having every where excavated their own valleys. The references and the reasoning were necessarily general, because the question itself is one of the most general that can be agitated, including the excavated vales in the course of every stream throughout every country; and yet this widely extended case, Mr. Farey would have to be determined by the datum of a solitary valley, or a local spot: and by frittering the natural magnitude of the question down to the subordinate and puny case of what has become of the excavated materials. Now admitting, in its fullest extent, all that Mr. Farey has advanced on this latter head, what would the whole infer, but either that the valleys have never been excavated at all, or that the materials carried off have been removed to situations and distances where we can no longer trace them? So strongly incongruous and unphilosophical are many of his notions of valleys, that, probably enough, he may deny the excavations altogether, although there does not exist a quarry or gravel pit in the kingdom, that bears more unequivocal indications of excavation than do our numerous ranges of valleys. But, on the other hand, if Mr. Farey admits of the excavation of valleys, in that admission he fully accedes to the removal of the missing materials: and by what practical or even possible direction will he contrive to carry them off, other than downwards in the same direction with the streams, where, however, he so obdurately denies they have ever travelled? His avowal that he is proud to repeat his belief in the probability, that valleys have been purposely and specially formed for the streams which now flow through them, and that it is engaging much of his attention, really surprises me. That the channel of a canal has been purposely and specially
formed

formed for the water afterwards let into it we well know, and we also know by what means the work has been accomplished; but what are the wonderful and never-yet-imagined means by which Mr. Farey will contrive to effect the excavation of thousands, I had almost said millions, of uniform valleys, expressly for, and previous to, the streams being let into them? That he never can discover and apply any *natural* agency equal and applicable, in the remotest degree, to so extensive and uniform a task, is unquestionable, and if *supernatural* agency be in his contemplation, I must decline following him into such a region. But what is the cogent reason which Mr. Farey thinks is sufficient to justify his broaching so strange a hypothesis? He has discovered a few excavated vales, on heights where no streams now flow: and their existence he deems sufficient to throw into utter obscurity the origin of all other excavated valleys. Now, though these few elevated vales are out of the reach of either present or former streams, does it thence follow that they are also out of the reach of rain, torrents, or even of those water-spouts which Mr. Farey pours down on another occasion, when their aid was quite unnecessary? Has Mr. Farey never heard of the vast and profound chasms in the mountainous tracts of the torrid zone, and which are nothing but excavations produced by the temporary torrents during the rainy season? And has he not seen innumerable excavations, though on a far less scale, in the hilly districts of our own country, also evidently the produce of occasional rainy torrents? For what other purpose then can a few such paltry instances be held out, but to darken and obscure the true state of the general question of excavation?

But to return to the subject of the missing materials, Mr. Farey is daily in the habit of treading on travelled matter without knowing from whence it has been brought, and of observing other spots from which immense masses of matter are missing, without being able to form a conjecture as to where they have been carried; and these facts of finding and missing removed matter, without any trace from whence, or to whither, it has been transported, are amongst the most familiar of geological phenomena, nor is there any practical or probable agent in Nature for all this universal tossing and shifting but *water*: yet because Mr. Farey cannot satisfy himself as to the precise identity and present situation of the comparatively trivial portion of matter carried away from excavated vales, he thinks that circumstance alone sufficient to justify an unlimited denial

that the streams, the only visible and conceivable agents for such a work, can have had any share in the excavation and transportation of the missing materials. He has, however, in his first paper, somewhat ungroundedly admitted, that he had discovered a little of the alluvia carried down by streams and brooks, adding, indeed, as a suitable qualification, that they are found so near to the currents as to be naturally enough referred to torrents which hurry through the valleys in ordinary rains. It is very unusual to find Mr. Farey treading on such natural ground as this; and accordingly, as if uneasy in his new situation, he instantly couples with these natural torrents, imaginary waterspouts, to assist in carrying down the few basketfuls of alluvial materials which, so unluckily for his own system, he had stumbled upon.

Even allowing Mr. Farey his own way, in calling this quantity which he has discovered only the thousandth part of the whole, I should still imagine that rain and torrents were quite as efficacious in their power, of transportation at the time the valleys were excavating, as now; and indeed, they certainly were much more so; as the numerous falls which must then have existed, would add greatly to the abrading forces of the currents; and I also think, that where we now find a portion, though it were only a thousandth part, actually lodged where it must have been brought down by the stream, it will be to every one but Mr. Farey himself, a rational conclusion, that the rest, however considerable, has travelled off in the same direction; and that the portion left for our inspection is satisfactory evidence of the other portion having also passed downwards, but beyond the limits of our further tracing, into the great receptacle of all—the ocean.

But all this cavilling about what has become of the excavated materials, is mere quibbling on a subordinate fact, which, however it may be disposed of, will still leave the great and general question of excavation and its agents undetermined; and even this fact, to any impartial and competent person, who will take the trouble of verifying it, will be found most substantially as I before represented it. I have never yet inspected a flat traversed by the serpentine windings of a stream, without finding every part of the channel cut, in many instances to a considerable depth, through alluvia corresponding with the strata higher up the stream: and not only the whole of the flat, but also up to certain heights on the surrounding eminences, abounded with the same transported matters. In truth, the universal
dissemination

dissemination of alluvia along the channels and vicinities of streams is as evident and palpable as the streams themselves. The immense beds which form the æstuaries, and still more the deltas of large rivers, at their entrances into the ocean, are all formations from matter that has travelled down the respective streams, and yet in all probability these enormous quantities bear no proportion to those which have passed on into the sea.

At the mouths of the Rhine and Scheldt, where the public attention is at this time so interestingly engaged, whole and very extensive countries have been formed, from the alluvia brought down by these rivers; and every other river on the globe affords the most unequivocal evidence of the vast masses of earthy and stony matter which have travelled down its waters. Every brook swollen with rain, and every stream occasionally flooded with ten times its usual proportion of water, surcharged to such an excess, with muddy materials, as frequently to smother multitudes of fish in their natural element, are all facts which are continually presenting themselves to our senses; and yet, if Mr. Farey is to be our guide, all these are palpable deceptions: the carrying power of streams is all absurdity, and all the endless masses of alluvia which every where accompany flowing water, have dropt from the moon, or travelled up the streams from the sea, but can never have found their way by so easy and natural a course as down them.

Mr. Farey cannot discover any where in the course of the streams, the bottoms of ancient lakes, as described in my former paper; but that I consider as a mere play on the word lake, for he does not assert that the flats which he has inspected do not abound with alluvia, but only that they have not, in his opinion, been the site of former lakes. If Mr. Farey will deny that the flats traversed by streams do abound with alluvial matters, our veracities will then be at issue, not on a matter of opinion, but of fact. I gave a very simple rule for ascertaining where lakes formerly existed, and had it contained any fallacy, its refutation would have been easy. It was to suppose the present valleys filled up, the streams still continuing to flow, and then to observe where the water would accumulate into a lake, and on that spot alluvia and every other indication of a former lake would now be formed.

Mr. Farey also speaks of having looked for the beds of former lakes in the valleys, where no one would imagine they ever could have existed. It was on the flats and in

the hollow immediately above a valley, where I expressly limited their former existence. Mr. Farey also thinks the Cumberland and Westmoreland lakes, not having given way and become valleys (an absurdity I never imagined,— flats, and not valleys, are what I have supposed former lakes to have left,) afford strong presumption, that my notions on the subject are erroneous; but he ought to have known that there are two distinct natural processes by which lakes may become exhausted. The one is where the stream, leaving the lake, has a sufficient fall over yielding strata to effect the excavation of a valley back into the lake. The other is where the stream flowing into the lake brings down alluvia sufficient in time to fill it up. In general both of these operations are in action at the same time, and that was strictly the case with the lakes which I described as having existed in the course of streams. There are also two distinct circumstances which may prolong the existence of lakes. The one is where the fall in the stream leaving the lake is too inconsiderable either to give the necessary force to the descending power of the stream, or to admit of its cutting a channel backwards sufficiently deep for the discharge of the lake. The other is where, with a sufficiency of fall, the stream is crossed by a stratum of indurated rock, so durable as effectually to resist the abrading forces of the stream. The former is the case with several of the principal Scotch lakes, which are situated near to, and but little above, the level of the sea. The latter is the case with almost all the numerous lakes in Canada, where the many magnificent falls, on the same streams, and always below the lakes, incontrovertibly point out the cause which has preserved the lakes.

Mr. Farey asserts, that “it is by no means a general truth, that, if the matters removed from the strata to form valleys were replaced, there would still be a sufficient fall in the country for the streams to flow the *same way*.” I certainly never meant, nor could any one understand me to mean, that the streams would flow over precisely the identical channels which they now do, but in nearly the same way or direction; and I conceive, that when a very great majority of the instances in a case are similar, that similarity constitutes a general truth. Now out of the many hundred streams which Mr. Farey has seen, he points out two solitary instances only, as differing from my description; adding, indeed, that other instances are very numerous, and that I shall be forced to admit that excavated

vales do not *always* follow the lowest ground; that is, the natural fall of the country. This looks like a mere quibble on the word *always*. My expression was, "that we may always be assured that the course which the stream has taken is the lowest descent of the country in that direction," nor do I conceive it possible to state a more correct, or a more widely extended general truth. The *general* direction of excavated valleys and their streams is, indeed, universally along with the common fall of the country; and it is a most important fact in the main question, for it both illustrates and confirms the excavation of the vales by streams; seeing that the excavation has continually proceeded in the same direction with the natural fall of the country, and, consequently, with the original course of the streams. Indeed, so substantially true is the proposition which I advanced, and which Mr. Farey finds it so necessary to his purpose to deny, that there is an absolute physical impossibility of streams, when left to themselves, flowing in any other direction than the lowest fall of the country over which they have to flow. To suppose otherwise, would require them either to ascend, or instinctively to avoid descending, in some parts of their course.

Mr. Farey also asserts, "neither is it true that, in *every instance*, the angle of intersection of valleys and streams is acute above and obtuse below, or that two streams *invariably* meet on *precisely* the same level." Here, again, if the denials have any meaning at all, it is mere quibbling on the words in italics. Has Mr. Farey ever seen an instance where the intersections spoken of occurred with angles acute below and obtuse above: that is, where the streams coalesced by meeting each other? Or where has he seen, at the confluence of two streams, the one falling from a height into the other? And yet, if he has seen both, and that very frequently too, what must I think of his concealing some of the most material general truths in the question? He may, indeed, have seen, and I suppose they are what he alludes to, a few instances of a trivial rill trickling over a bank, at right angles into a stream; but would he balance such instances against those to which I referred, and which are as numerously disseminated over this and every other country as are the streams themselves? The truth assuredly is, that these objections were convenient for putting aside a string of general facts and reasoning, which the most ingenious and artful hypothesist, who denies the action of the streams, dares not either directly oppose or venture to illustrate, by fairly meeting the

practical facts in the general question. And, notwithstanding all Mr. Farey's denial, for he has yet offered nothing in the way of argument, it is a general truth diffused over the whole surface of the globe, that excavated valleys and their streams do coincide in their direction with the natural fall of the country, and do intersect at angles also corresponding with that fall, and at corresponding levels; and while this vast unison of effects absolutely demonstrates the action of the streams as its natural cause, it is utterly and altogether inexplicable by any other natural process or operation.

Hence it is, that Mr. Farey has never yet ventured to hint at what he deems the natural cause of the excavation of vales; and with a larger portion of that confidence which he condemns, and which, without having truth on its side, would, indeed, be the extreme of absurdity, I venture to pronounce his entire incapacity to afford any probable solution of those extensive general truths—the elevated situation of the spring-heads—the common direction of the vales and streams with the fall of the country—and their uniform intersections and levels. He committed himself in the first instance by denying the action of the streams, and in doing so he has completely shut himself out from the question, and is now utterly unable to advance a single step towards its elucidation.

Hitherto Mr. Farey has only tried to extinguish the lights held up, and endeavoured to throw the general question into utter darkness, by balancing petty and puny exceptions against a more extensive chain of general and harmonizing facts than are to be met with in any other portion of geology; and it is this spirit of altercation working only to conceal and obscure, instead of entering with fair views into the just merits of the general case, that has constrained me to speak so strongly as I have done. I was, and am still, disposed to think very highly of Mr. Farey, as an exceedingly acute, intelligent, and industrious observer; but every thing he has yet said on the subject of valleys proves how justly I appreciated his talents as an investigator of natural causes.

The only obscurity, I am well convinced, which hangs over the natural excavation of valleys, arises from not duly estimating the mechanical action of water when rapidly descending a declivity over the ordinary materials of our earth. There is not, perhaps, a mountain on the globe, which a stream of water will not cut in two, allowing it only a sufficient fall, and a sufficiency of time: two circumstances

cumstances which have universally existed in the excavation of vales. In the mountainous districts of the tropical regions, gullies and ravines are frequently cut, to a vast depth, through the hardest rock, merely by the temporary torrents which descend during the rainy season; and similar effects, but of far less magnitude, may be every where seen in the hilly districts of our own country. And even the bursting of a canal through its banks, or the overflowing of a flooded river into a new tract, will often, in a few hours, effect astonishing excavations, and carry away amazing portions of matter. Extensive meadows in this neighbourhood have been covered several feet in depth, with sand and other alluvia brought down by the Mersey in a single night. But it is really painful to be compelled to refer to such ordinary occurrences in support of so obvious a fact, as that a stream of water, falling over a declivity, will there effect an excavation proportional to the height of the fall, and the yielding nature of the strata.

Now if we consider that the sources and spring-heads of all streams, without perhaps an exception of one instance in a thousand, and that admitting of an easy and natural explanation, are situated above the level of the country out of which the valleys have been excavated, and previous to the excavation must have flowed over it, and that the present depths of the valleys satisfactorily prove that the streams must have had falls equal to these depths, we shall surely find, in the natural progress and descending forces of the streams, all the means necessary to have effected the excavations; and when in addition to all this we actually find so many of the phænomena of streams and valleys precisely corresponding with such an action of the waters, we surely possess a quantum of harmonizing evidence, which will support the most confident conclusion; and it would but ill comport with the liberal spirit of philosophical research to turn away from such a mass of evidence, and substitute for such obvious and natural agency, some baseless phantom of hypothetical enigma.

I cannot but lament that Mr. Farey should voluntarily have made himself an habitual alien to that beautiful simplicity which pervades and governs all the operative works of Nature, and which constantly rises in dignified unity with the magnitude of the occasion. The falling of an apple from a tree is said to have suggested to Newton the first idea which led him to the development of his great scheme of universal gravitation: nor do I consider water as less active and important in geology, than gravity is in

the planetary system; for it assuredly is the great and simple instrument for moving and moulding all the exterior and interior parts of our earth. Hence alone we can discover the obvious reason why it bears so large a proportion on the surface of the globe. Its present quantity and extent are indispensable to effect that gigantic transportation of ponderable matter, which all the strata of the earth testify, which the principles of renovation in such a material system require, and which no data we now possess can authorise us to doubt is now in as full force and action as at any former period. Nor have we any reason to despair that human sagacity and science, at present so active in the investigation of Nature, will in due time be enabled to develop those laws by which alternations of sea and land have been, and doubtless yet continue to be effected, with as much precision as planetary bodies are wheeled in their several orbits. For puny and unphilosophical indeed must his views of nature be, who can imagine that the whole portion of the earth, on which the very existence of all its organized beings is dependent, has hitherto been moulded and fashioned by fluctuating and fortuitous laws, and is yet to be the sport of accidental violence, or that its continual propensity to disintegration and waste has no restorative balance.

These extended views of geology, Mr. Farey will find it easy to call rhapsodical; but he will do wiser to give them a serious and just consideration, as an antidote against his fondness for the *ignis fatuus* of hypothesis. It is only by such new impressions that his mind can be weaned from rambling after and bringing down other worlds, to patch up and eke out our own. His geological surveys merit the highest praise. Such pursuits, indeed, are of great national interest, and I can truly assure him that he has no friend who more sincerely wishes him every support and success than myself; but if he continues in his singular and obdurate prejudices against the efficacious and important action of moving water, as the general operator of geological phenomena, as well on the surface, as in the stratified regions of the interior of the earth; he may, indeed, be the collector of a numerous assemblage of valuable facts, but it will be left to others to employ them, successfully, in the investigation of that common cause which has disseminated such a diversity of effects in and over every part of the globe. I am, sir, your most obedient humble servant,

JOHN CARR.

Princess Street, Manchester,
Sept. 7, 1809.

XXVIII. Further

XXVIII. *Further Remarks on Thunder Storms.* By
Mr. CORNELIUS VARLEY.

To Mr. Tilloch.

SIR, SINCE the period at which I sent you some remarks on a thunder storm * seen at a distance, I have been nearly under a similar storm, and have remarked two additional effects, which appear to me to throw some light upon this subject.

Toward the close of a fine day the air grew thick with vapour, but exhibited no visible form of clouds. This vapour afterwards condensed into thicker masses, with faint flashes of lightning about them. The condensation then went on very rapid, so that what was only a thick mist before, became, in an hour, a large general mass of clouds; and I could now see clear sky in different parts, though at the commencement the whole sky was covered with a faint mist. There was now a great deal of lightning between the upper and lower clouds, the effect of which was seen through the under clouds in broad, misty, zig-zag flashes; and nearer the horizon were seen large sparks running along between the clouds to a great distance. The passage of the light was visible all the way, but the spark seen distinctly at all the openings.

During the time this lightning continued there was only now and then a little thunder, which I think is clearly accounted for by an accompanying effect—namely, the condensation of a very rare cloud into one more dense, but yet quite elastic. The condensation may be conceived to take place by the closing together of an immense number of small parcels of clouds, as if the parts of a sponge were made to approach by pressure, and therefore with a very soft and gentle vibration.

But when a spark strikes from the lowest cloud to the earth the condensation must be into rain, (for there is no intermediate state between that cloud which is already at its lowest density and rain,) therefore the atmosphere has to collapse upon solid inelastic particles of rain, which must produce a sharp clap; and this every person knows to be the effect, when lightning strikes down from over our heads.

The wind during all the day had been south-west, but when the storm commenced the wind ceased on the north-

* See page 161 of the present Volume.

east side of it, and seemed afterwards to return; for after every large flash of lightning I felt an evident current of wind blowing towards the focus of condensation, which had settled considerably westward of me.

I did not see many sparks strike to the earth, but there were distant showers of rain, and it thundered and rained very hard in the night.

I am, sir, your very humble servant,

Paddington,
August 18, 1809.

CORNELIUS VARLEY.

XXIX. *Analysis of the Mécanique Céleste of M. LA PLACE.*
By M. BIOT.

[Continued from p. 43.]

BOOK THIRD.

THE author having in his first volume established the laws according to which the centres of gravity of the celestial bodies move, proceeds in the second to consider the phænomena occasioned by the figure of these bodies, and the circumstances peculiar to each. However great the extent and importance of the inquiry contained in the first volume may be, the second is still more remarkable, on account of the difficulty of the subject, the elegance of the analysis, and the great ingenuity with which it is applied.

The author proceeds to treat of the figure of the celestial bodies. This figure depends on the law of gravity at their surface, and this gravity, the result of the attractions of all the molecules which compose them, depends on their figure. The connection between these two unknown quantities renders their determination very difficult. The author resolves this problem by supposing the celestial bodies to be covered by a fluid: the method employed by him to obtain this, is a very singular application of the calculation of partial differences, which leads by simple differentiations to the most extensive results.

Considering, in the first place, the spheroids as being homogeneous, he forms the expression of their attractions upon a point given with respect to three rectangular axes. The expression depends on a triple integral, which is susceptible of a convenient transformation. The author then develops the general principle, applying these results to spheroids terminated by finite surfaces of the second order; and supposing, in the first place, the point attracted to be within the spheroid, he thence deduces that a point placed
in

in the interior of an elliptic stratum, whose internal and external surfaces are alike, and similarly situated, is equally attracted by all parts.

He afterwards obtains the attractions of the spheroid with respect to the three rectangular axes, by means of a single definite integral; but this integral only being possible in itself, when the spheroid is one of revolution, the author makes an application of it to surfaces of this kind, and determines in finite terms the value of their attractive force on a point placed in their interior.

He afterwards considers the attraction of the same spheroids on an external point. This inquiry presents more difficulties than the preceding, but it may however be referred to it. With this view the author calls to recollection that the attractions of the spheroid, parallel to the three axes, are given by the partial differences of the function which expresses the sum of the molecules of the spheroid divided by their respective distances from the points attracted. He obtains the value of this function, when the point attracted is at a very great distance, and he gives an equation of the second order of partial differences which determine it generally. He afterwards shows, by the help of series, that this function is the product of two factors, one of which is the mass of the spheroid, and the other is merely the function of its eccentricities, and of the co-ordinates of the point attracted; whence it follows, that the attractions of two elliptic spheroids which have the same centre, the same position of the axes, and the same eccentricities on the same external point, are to each other as the masses of these spheroids. It also follows from this property, that in order to obtain the attraction of the proposed spheroid on the point attracted, it is sufficient to know the attraction on the same point of a spheroid, whose eccentricity and position of the axes are the same, and the surface of which would pass by this point. The author shows that there is but one spheroid which satisfies this condition. The research after the attraction of these spheroids in points which are exterior to them is thus referred to the case where the attracted point is on their surface. Hence results the expression of this attraction in finite terms, when the spheroid is an ellipsoid of revolution, which completes the theory of the attraction of elliptic spheroids. The author gives the method of extending these results to the case where the attracting spheroid is composed of variable elliptic layers, of density, position, and eccentricities, according to any given law. He afterwards considers

considers in a general manner the attractions of any spheroids; he recollects in the first place that this attraction is given by an equation of the second order of partial differences. The whole theory of the attraction of spheroids flows from this fundamental equation. The author, after making it undergo various transformations, undertakes to deduce from it, by means of series, the value of the function required; he then shows that with respect to spheroids which differ very little from the sphere, we may attain them without the aid of integration, by means of a very remarkable equation which takes place on their surface. It is sufficient for this purpose, to develop their radius in a series of functions of a particular kind, given by the nature of the question. The author proves that this development can take place in one way only, and gives shortly afterwards a very simple method of forming it. He afterwards establishes a very elegant theorem relative to the definite integration of double differentials which are the products of two of these functions, and he deduces from them, that we may get rid of the first two terms of the development of the radius of the spheroid, by fixing the origin of the co-ordinates at its centre of gravity, and taking for the sphere, which differs very little from it, that which is equal to it in volume. By the help of these considerations, the author obtains, in the simplest manner, the attractions of homogeneous spheroids differing little from the sphere on the points which are either interior or exterior to them; and he extends these results to the case in which the spheroids are heterogeneous, whatever in other respects may be the law according to which the figure and density of their layers vary. Passing afterwards to the inquiry respecting the attractions of any given spheroids, which depend equally on the function expressing the sum of their molecules divided by their respective distances from the point attracted, the author shows that this function may be easily determined, when we have its expression in series, for the two cases where the point attracted is situated on the prolongation of the axis of the pole, or in the plane of the equator. This consideration, which simplifies considerably the inquiry in question, being applied to the ellipsoid, furnishes a new demonstration of the theorem mentioned above, and which consists in this, that the function which determines the attraction of these bodies is the product of two factors, one of which is the mass itself of the ellipsoid, and the other only depends on the eccentricities and position of the axes.

The author afterwards considers the figure which spheroids,

roids, supposed to be fluids, would assume in consequence of the mutual attraction of all their parts, and of the other forces which act upon them. For this purpose he seeks the figure which satisfies the equilibrium of a homogeneous fluid mass, endowed with an uniform rotatory motion about a fixed axis. He supposes this figure to be that of an ellipsoid of revolution, whose rotatory axis is the axis of revolution itself. He determines the attractive and centrifugal forces which flow from this hypothesis; and, substituting them in the equation of the equilibrium of fluids, he thence obtains an equation independent of the co-ordinates of the surface, which establishes the relation that must exist between the eccentricity of the spheroid and the polar axis, in order that the equation of equilibrium may be satisfied. Hence it follows, that the elliptic figure satisfies the conditions of equilibrium, at least when the ratio of the eccentricity to the polar axis is properly determined in the function of the centrifugal force, and of the density of the body. On this supposition, the gravity at the pole, is to the gravity at the equator, as the diameter of the equator is to the polar axis, and we deduce from it the general relation of the latitude to the gravitation. These results also make known the ratio of the eccentricity to the polar axis, and that of the centrifugal force to the density of the body, by means of the length of the seconds pendulum, and the length of the degree of the meridian, both being observed in the same point of latitude. The author applies these formulæ to the earth, supposed to be an ellipsoid of revolution and homogeneous; and fixes on this hypothesis the ratio of the polar axis to the diameter of the equator.

The author afterwards examines whether the equation which gives the ratio of the eccentricity to the polar axis be susceptible of several real roots. He shows that with respect to the same motion of rotation, the number of these real roots is reduced to two, whence it results, that to the same angular motion of rotation two different figures of equilibrium answer; but the rapidity of this motion is limited, for equilibrium could not take place with an elliptic figure when the duration of rotation does not surpass the product of one hour and 90 seconds, into the square root of the ratio of the mean density of the earth to that of the fluid mass. The time is here reckoned according to the new division. The observed rotations of Jupiter and of the sun are within the limits of this duration.

One would suppose that this limit is the one at which the
fluid

fluid would begin to be dissipated in consequence of a very rapid rotatory motion. The author shows that this is not the case, since at this limit the gravity at the equator still surpasses the third of the gravity at the pole; whence it follows, that if the equilibrium ceases to be possible, it is because with a more rapid motion we could not give to the fluid mass an elliptic figure, so as to make the result of its attraction and of the centrifugal force perpendicular to the surface.

The author afterwards examines if equilibrium can subsist with a figure elongated towards the poles, and proves that this could not take place. What has been said as to the possibility of two states of equilibrium relative to the same angular motion of rotation, does not carry with it this possibility relative to one and the same primitive force: in order to know what ought to be concluded in this respect, the author considers a fluid mass primitively agitated by any given forces, and then abandoned to itself and to the mutual attraction of all its parts: by the centre of gravity of this mass supposed to be immoveable, he conceives a plane on which the sum of the areas, described by the projections of the radii vectores of each molecule, and multiplied by the respective masses of these molecules, to be at the commencement of the motion a maximum. This plane will constantly maintain this property; also, when after a great number of oscillations the fluid mass shall assume an uniform rotatory motion about a fixed axis, this axis will be perpendicular to the plane just mentioned, which will consequently become that of the equator, and the rotatory motion will be such that the sum of the areas on this plane will remain the same as at the origin of the motion. This consideration determines the motion of rotation and the figure of the body; whence it follows, that with respect to the same primitive impulse, there is only one elliptic figure which can satisfy the equilibrium. The author observes, that the axis about which the rotatory motion is established, being, from the origin of the motion, perpendicular to the plane of the maximum of the areas, was also at this period the axis of the greatest moments, and we find that it still preserves this property during the motion. This constancy in the initial properties forms a remarkable and hitherto unnoticed analogy between the axis of the greatest moments and the place of the maximum of the areas.

The author, in what precedes, has shown that the elliptic figure

figure satisfies the equilibrium of a homogeneous fluid mass, endowed with an uniform rotatory motion about a fixed axis; but in order to resolve this problem completely, we must determine *à priori* all the possible figures of equilibrium, or ascertain that the elliptic figure is the only one which fulfils these conditions. We perceive besides, that in the inquiry into the figure of the planets we ought not to confine ourselves to the case of homogeneity; but then, this inquiry, considered in a general point of view, becomes extremely difficult. Fortunately it is simplified relatively to the planets and satellites, on account of the small difference which exists between the figure of these bodies and that of the sphere, which admits of our neglecting the square of this difference and the quantities which depend on it. In order to treat this problem in the most general manner, the author considers the equilibrium of a fluid mass covering a body formed of layers of variable densities, endowed with a rotatory motion about a fixed axis, and solicited by the action of foreign bodies; and he establishes the general equation of this equilibrium, when the covered spheroid differs very little from a sphere. This spheroid may besides be entirely fluid; and it may be formed of a solid nucleus covered by a fluid: in these two cases, which are reduced to one only, if the spheroid be homogeneous, the preceding equation determines its figure, that of the fluid strata which cover it, and also gives, by simple differentiation, the variation of the gravity at its surface. When there are no foreign bodies, in which case the spheroid, supposed to be homogeneous and of the same density as the fluid, is only solicited by the attraction of its molecules and the centrifugal force of its rotatory motion; its figure becomes that of an ellipsoid of revolution, on which the increases of gravity and the diminutions of radii are proportional to the squares of the sines of the latitudes; from all which the author concludes that the elliptic figure is then the only one which satisfies the equilibrium. This demonstration rests entirely on the sole hypothesis, that the figure of the spheroid differs very little from the sphere; but it requires the development of the radius of this spheroid in a series of functions of a particular kind, which the author has demonstrated above to be always possible: but in order to avoid all the difficulties which this development might give rise to, he resumes the same problem by a direct method, and independent of series; this method consists in the first place in transforming the equation of equilibrium in such a way as to tender it linear with respect to the radius

vector

vector of the spheroid. Supposing afterwards the action of foreign powers to be nothing, we deduce from this equation, and by differentiations only, that if the spheroid sought be one of revolution, it can only be an ellipsoid which is reduced to a sphere, when there is no rotatory motion; so that the sphere is the only surface of revolution which satisfies the equilibrium of an immoveable homogeneous fluid mass. Hence it is afterwards concluded generally, that if the fluid mass be solicited by any very small forces whatever, there is only one possible figure of equilibrium; for, by supposing that there are several, there would of course be several different radii, which being substituted in the equation of equilibrium, would verify it; and as this equation is linear with respect to these radii, the sum of any two of them would still satisfy equally as well as their difference. Hence the author ingeniously deduces, that this difference must be nothing; from which he concludes, that the spheroid can be in equilibrium in one way only.

Afterwards comes the consideration of the equilibrium of a homogeneous fluid mass which covers a spheroid of a different density. On this head he observes, that we may regard this sphere as being of the same density with the fluid, and place in its centre a force reciprocally as the square of the distances. By means of this consideration, we easily obtain the equation of equilibrium for this spheroid; and it results that there are generally in this case, and when the spheroid is one of revolution, two figures of equilibrium. When there is no rotatory motion, and when we consider the foreign forces as nothing that mutually attract the molecules of the body, one of these two figures is spherical, and both are so if the spheroid be homogeneous; which confirms the preceding results.

After having thus obtained the figures of revolution which satisfy the equilibrium of a homogeneous fluid mass which covers a sphere, the author gives the method of deducing from it those which are not of revolution. With this view he transfers to any given point the origin of the angles which determine the position of the radius vector in space, angles which were previously taken into account, reckoning from the extremity of the axis of revolution. By this method all these angles enter into the expression of the radius vector; and as, in consequence of what precedes, this radius satisfies the equation of equilibrium, whatever may be the position of this new origin, it will still satisfy it when we vary this origin in any way whatever. This variation only influences the excess of the radius vector of the spheroid

roid above that of the radius of the sphere, from which it differs very little; and as the equation of equilibrium is linear with respect to the radius of the spheroid, it will still be satisfied if we add any number of these excesses to the constant part which enters into the expression of the radius vector. The spheroid to which this radius belongs is no longer of revolution; it is formed by the sphere from which the spheroid differs but little, augmented by any number of layers similar to the excess of the primitive spheroid of revolution above this sphere; these layers besides being laid arbitrarily above each other. The author shows that these results may also be deduced from the reduction into a series of the attractions of the spheroids; which proves that the results obtained by this method have all possible generality, and that there is no fear of any figure of equilibrium escaping them. This result confirms what has been previously seen, that the form given to the radius of the spheroids is not arbitrary, and flows from the very nature of their attractions.

The author afterwards takes up the general equation of the equilibrium of spheroids differing little from spheres, and covered with fluid layers of variable densities. He deduces from it the equation for the figure of these layers. Examining particularly the case in which the spheroid supposed to be entirely fluid is not solicited by any foreign action, he shows that it can then only be an ellipsoid of revolution whose ellipticities increase and densities diminish from the centre to the surface; he obtains the equation which determines the ratio of these quantities to each other, and he deduces the limits of the oblateness of the spheroid; the former answering to the case of homogeneity, the other to that in which gravity would be directed towards a single point. Such must have been the figure of the earth, if supposed to have been primitively fluid. In the case now in question, the directions of gravity from the surface to the centre no longer form a right line, but a curve, the equation of which is determined by the author, and which is the trajectory at right angles of all the ellipses, which by their revolution form the layers of the level of the spheroid.

[To be continued.]

XXX. *On Crystallography.* By M. HAUY. Translated from the last Paris Edition of his *Traité de Minéralogie.*

[Continued from p. 108.]

DECREMENTS ON THE EDGES.—Let ss' (fig. 11, Pl. II.) be a dodecahedron with rhombic planes. This solid, which is one of the six primitive forms of crystals, also presents itself occasionally as a secondary form, and in this case it has as a nucleus, sometimes a cube and sometimes an octahedron. Supposing the nucleus to be a cube :

In order to extract this nucleus, it is sufficient successively to remove the six solid angles composed of four planes, such as $s, r, t,$ &c., by sections adapted to the direction of the small diagonals. These sections will display as many squares $AE O I, EO O' E', IO O' I'$ (fig. 12) &c., which will be the faces of the cube.

Let us conceive that each of these faces is subjected to a series of decreasing laminæ solely composed of cubic molecules, and that every one of these laminæ exceeds the succeeding one towards its four edges, by a quantity equal to one course of these same molecules. Afterwards we shall designate the decreasing laminæ which envelop the nucleus by the name of *laminæ of superposition*. Now it is easy to conceive that the different series will produce six quadrangular pyramids similar in some respects to the quadrangular steps of a column, which will rest on the faces of the cube. Three of these pyramids are represented in fig. 13, and have their summits in s, t, r' .

Now as there are six quadrangular pyramids, we shall therefore have twenty-four triangles, such as $Os I, Ot I,$ &c. But because the decrement is uniform from s to t , and so on with the rest, the triangles taken two and two are on a level, and form a rhomb $sOt I$. The surface of the solid will therefore be composed of twelve equal and similar rhombs, *i. e.* this solid will have the same form with that which is the subject of the problem. This structure takes place, although imperfectly with respect to the crystals called *boracic spars*, and the effect of the decrement on which it depends attains its limits in a substance the nature of which is not yet well determined, and which we shall more particularly explain hereafter.

The dodecahedron now under consideration is represented by fig. 13, in such a way that the progress of the decrement may be perceived by the eye. On examining the figure attentively, we shall find that it has been traced on the

the supposition that the cubic nucleus has on each of its edges 17 ridges of molecules; whence it follows, that each of its faces is composed of 289 facets of molecules, and that the whole solid is equal to 4913 molecules. On this hypothesis, there are eight laminæ of superposition, the last of which is reduced to a simple cube, whose edges determine the numbers of molecules which form the series 15, 13, 11, 9, 7, 5, 3, 1, the difference being 2, because there is one course subtracted from each extremity.

Now if instead of this coarse kind of masonry, which has the advantage of speaking to the eye, we substitute in our imagination the infinitely delicate architecture of nature, we must conceive the nucleus as being composed of an incomparably greater number of imperceptible cubes. In this case the number of laminæ of superposition will also be beyond comparison greater than on the preceding hypothesis. By a necessary consequence, the furrows which form these laminæ by the alternate projecting and re-entering of their edges will not be cognizable by our senses; and this is what takes place in the polyhedra which crystallization has produced at ease, without being disturbed in its progress.

We may remark that instead of twenty-four decrements, which act two and two from one side to the other of each ridge, we may limit ourselves to admit only twelve, by considering each of the twelve others as being the continuation of the former. For instance, we may suppose that decrements act directly towards the four edges of the basis $AEOI$, (fig. 12) and towards those of the inferior basis, in order to produce the two pyramids which have their summits in s and in s' , and that with respect to the other faces of the cube, they act solely towards the two edges II' , OO' , and towards the opposite edges behind the cube, to produce secondary faces situated like ItI' , OtO' . On this hypothesis, if we conceive that the effects of the decrements are prolonged from the other side of the edges which have served them as parting lines in such a manner that these prolongations, combining with the faces produced by the immediate action of the decrements, circumscribe a space, we shall evidently have the same dodecahedron. We shall afterwards see the utility of this remark.

If the laminæ applied on the cube decreased on all sides by two or more courses, then the pyramids being more elliptical, and their adjacent faces being no longer two and two on the same plane, the secondary crystal would be terminated by 24 distinct triangles.

We call *decrements in breadth* those in which, as well as in the preceding, each lamina has only the height of a molecule; so that their whole effect by one, two, three, &c., courses, is in the way of breadth. *Decrements in height* are those in which each lamina, exceeding only the following one by a single course in the direction of the breadth, may have a height double, triple, quadruple, &c., to that of a molecule: this is expressed by saying that the decrement takes place by two courses, three courses, &c. in height.

The two kinds of decrement which we have mentioned are combined together in the following example taken from sulphuretted iron (ferruginous pyrites) with twelve pentagonal faces (fig. 14).

This variety has also for its nucleus a cube, the position of which with regard to the dodecahedron is sensible by the bare inspection of fig. 15. We there see that the portions superadded to the nucleus, instead of being pyramids, as in the preceding case, are species of wedges which have for their external faces two trapeziums, such as $O I p q$, $A E p q$, and two isoscele triangles $E p u$, $A q I$.

Let us conceive that the decrements are here made by two ranges in breadth, between the edges $O I$ and $A E$, $I I'$ and $O O'$, $E O$ and $E' O'$, and in a similar manner and at the same time on the opposite squares they are made by two ranges in height between the edges $E O$ and $A I$, $O I$ and $O' I'$, $O O'$ and $E E'$, by which we see that these decrements take place on the different faces of the cube, according to three directions which cross each other at right angles. Then the decrement by two ranks in breadth, tending to produce a more inclined face than that which results from the decrement by two ranks in height, each pile of decreasing laminae will no longer end in a point, but in a cuneiform solid (fig. 16); *i. e.* it will be terminated by an edge $p q$ or $t n$; and if we compare the directions of these two edges with that of the edge $r s$ (figs. 14 and 15) which terminates the pile raised on the face $E O O' E'$ of the nucleus, it will be easy to see that these three edges are perpendicular to each other in consequence of the traverse directions which the decrements take.

Besides, each trapezium, such as $O p q I$ (figs. 15 and 16) being on the same plane with the triangle $O t I$ which belongs to the adjacent pile, the union of these two figures will form a pentagon $p O t I q$; whence it follows that the solid will be terminated by twelve equal and similar pentagonal faces, on account of the regular form of the nucleus and the symmetry of the decrements.

Here

Here an important consideration for the verification of the theory presents itself. If we suppose that the different pentagons which compose the surface of the dodecahedron all uniformly depend on the different edges of the cube as on so many hinges, so that, for example, the two pentagons $ntI s' I'$, $ntOs O'$, are raised or lowered by the trapeziums $I t n I'$, $O t n O'$, while they will be raised or lowered in a contrary direction by the triangles $I s' I'$, $Os O'$, we shall have an infinity of different dodecahedrons, the faces of which will be so many equal and similar pentagons. Among these dodecahedrons, a part of them will be possible in virtue of some law of decrement, and others cannot be produced by any law, and will be purely geometrical solids. In each dodecahedron, the incidence of the pentagon $ntI s' I'$ on the pentagon $ntOs O'$, at the place of the edge nt , which determines of itself all the other angles, will have a particular measure; and calculation proves that, in the case of decrement now mentioned, this incidence ought to be $126^{\circ} 52' 8''$. Now by measuring that which corresponds with it on the dodecahedron of sulphuretted iron, we find it nearly 127° : thus the existence of the law of decrement is confirmed by the agreement of calculation with observation.

What we have now described also takes place with respect to all the other results of the theory compared with those of observation; whence we ought to conclude, that the measurement given by calculation is the true limits of the approximation found by means of the goniometer; so that the more carefully this instrument is constructed, the more distinctly is the crystal defined, the observer becomes more expert, and the nearer also do the results on both hands approach to perfect coincidence.

The observation already made with respect to the dodecahedron with rhombic planes applies as of itself to the present case; that is to say, instead of 24 decrements, viz. twelve of two courses in breadth, and the twelve others of two courses in height, we can confine ourselves to the consideration of the former twelve, only supposing their effects to extend from the edges of the other side, which serves them for parting lines.

We shall give a new example borrowed from metastatic carbonated lime (fig. 6, Pl. 1). We have seen, when examining the position of the nucleus, that the edges EO , OI , JK , &c., were confounded with the lower borders*

* I call *upper edges*, or border, those which are contiguous to each summit; and *inferior edges*, those which are opposite to the former, whatever may be the relative position of the rhomboid.

of this nucleus (fig. 7); whence it follows, that these same borders or edges are parting lines of the decrements, which in this case take place only with respect to them, without any relation to the upper edges.

Now it is easy to conceive, that the edges of the laminæ of superposition form altogether as many triangles, $E'sO$, $I's'O$, $E's'O$, &c., resting on those parting lines; and as these lines are six in number, there will be twelve triangles, six in the upper part and as many in the lower; and all these triangles will be scalene, on account of the obliquity of the parting lines.

With respect to the upper edges of the laminæ of superposition, they not only undergo no decrement, but it is even necessary that they should be prolonged, remaining always contiguous to the axis of the crystal, in order that the nucleus may continue to be enveloped towards its two summits, as in a state in which it might increase without changing its form.

It is also to calculation combined with observation that it belongs to determine the law of decrement on which the dodecahedron depends. Now if we suppose that this law acts by one range, we prove that in this case the two faces produced on both sides of the same edge would be on the same plane, and, besides, that they would be parallel to the axis; which could not agree with the present case. Therefore the simplest hypothesis which occurs is that of a decrement by two courses in breadth. Now in this case calculation demonstrates, that the dodecahedron arising from this law ought to have two remarkable properties; the one is, that the obtuse angle SEO of any one of its faces has precisely the same measure with the obtuse angle of the nucleus, *i. e.* it is $101^{\circ} 32' 13''$; the other consists in the respective inclinations of the faces of the dodecahedron at the meeting of the most salient edges; for instance, the inclination of sIO on sIK is equal to that of two adjacent faces towards the same summit of the nucleus, *i. e.* it is $104^{\circ} 28' 40''$. Now the mechanical measurement of the angles equally leads to the same degrees, and shows that the supposed law is in truth the law of nature. It is this kind of translation or metastasis of the angles of the primitive form on the secondary crystal, which has suggested the name of *metastatic* given to the variety in question.

Fig. 17 (Pl. III) will fully illustrate the explanation which we have just given. It represents only the kind of upper pyramid added to the nucleus, which being thus partly uncovered, enables us to comprehend more easily the progress

progress and effects of decrement by two courses. Each edge of this nucleus has been divided into ten; whence it follows that every face is an assemblage of a hundred small rhombs, which are the external facets of as many molecules. This construction requires but eight laminæ of superposition for each of the same faces; and these laminæ being united together three and three in the places which correspond to the upper edges of the nucleus, form kinds of decreasing envelopes which are successively generated, and the last of which is composed of eight small rhomboids. If we consider the position of the line $E s$ which represents one of the terminating edges, composed of all the solid angles which are contiguous to it, we shall remark that the geometrical summit s of the dodecahedron is situated a little above the physical summit s'' ; but this difference is considered as nothing, on account of its extreme minuteness.

What we have said as to increments assumed by the laminæ of superposition towards their upper edges, in continuing to envelop the crystal on this same side, is a consequence of this general principle, namely, that the portions of laminæ, situated out of the reach of the decrements, extend, by mutually retrieving themselves, in such a manner as to avoid the re-entering angles which seem excluded by the crystallization, at least in solitary crystals*. But we may abstract these simply auxiliary variations, as the effect of decrements only determines the form of the secondary crystal. It is even sufficient to take the decrements at their origin, in order to have as many planes; and these again being afterwards extended in idea until they meet, lead to the complete form of the polyhedron which they tend to produce. Hence it is thus that we confine ourselves to the consideration of the initial effect of decrements, in calculation of which the progress is always much more simple and expeditious than that of reasoning.

It is useful, however, to be also able to give a distinct account of all the details relative to the structure of a crystal, so that, if we have at our disposal a certain number of small solids similar to molecules, we may arrange them around a given nucleus, and thus produce an artificial imitation of crystallization. I shall therefore, in a final example taken from *equiaxis*-carbonated lime, follow lamina by lamina the progressive route of the decrements, and in some measure give the synthesis of the structure.

* Re-entering angles, when they exist in crystals, are accidents occasioned by peculiar circumstances, of which we shall hereafter speak.

The variety in question is a rhomboid much more obtuse than the nucleus, and the great angle of which is $114^{\circ} 18' 56''$. Fig. 18 represents it confined to its nucleus. In order to extract the latter at once, it is necessary to have planes trajecting by the oblique diagonals of the different faces of the secondary rhomboid. One of these sections, for instance, that which passes by the diagonals drawn from a to t , and from a to u , and which intercepts the solid angle z , coincides with the face $abdf$ of the nucleus. Now there are six solid angles situated laterally, viz. z, c, y , on one hand, and t, m, u , on the other. We shall therefore have six sections arranged three and three towards each summit; and as the upper solid angles alternate with the lower, the sections which intercept them preserving between themselves the same alternative, will cross so as to form six rhombs, which will give the surface of the nucleus.

In order to conceive the structure of the secondary rhomboid, let us resume the dodecahedron with rhombic planes, which, as we have seen, is produced by virtue of a decrement of one range of small cubes on the twelve edges of a cubical nucleus. The effect of this decrement in general is to produce on both sides of every edge, like OO' , (fig. 12) two triangular faces OrO' , OtO' , which being on a level form a rhomb $OrO't$, the small diagonal of which is the edge OO' , which has served for the parting line.

Let us now imagine that the nucleus is the primitive rhomboid $abaf$ (fig. 18) of carbonated lime. Let us conceive besides that the laminæ of superposition decrease by one range of small rhomboids similar to this nucleus, but solely on the three edges, ab, af, an , which join around the summit a , and on those which correspond with them in the lower part. Then, instead of twelve rhombs, no more than six will be formed, the small diagonals of which will be confounded, as in the other case, with the edges ab, af, an , &c.

The other parts of the laminæ of superposition, *i. e.* those which are situated towards the lower edges bd, df, fx , &c., as they do not participate in the decrements, will also undergo some variations, but which will tend merely to prolong the faces produced by these decrements, so as to make them intersect each other. Hence it follows, that the laminæ, instead of preserving the figure of the rhomb, as would happen if the decrement took place at once on all the edges, will pass successively in proportion as they shall become more remote from the nucleus, through the figure of the pentagon, and that of the triangle. The develop-
ment

ment of the structure will assist us in forming a clear idea of these variations.

Let $abdf$ (fig. 19 A) be the same rhomb with fig. 18, what we have to say with respect to this rhombus may be easily applied to the five others. Suppose it to be divided, as represented in fig. 19, into 81 partial rhombs, which may be considered as the external facets of so many molecules: hence we have 729 molecules for the entire nucleus.

The first lamina of superposition which must be applied on the rhomb $abdf$, will be that which we see in fig. 16 B, in which U/Zd' represents the grand external face, and CUU' , $XZUU'$, the two small superior faces. We shall arrange this lamina with respect to the face $abdf$ (fig. 19 A) so that the point h' may be blended with the point h , the point A' with the point A , and the point B' with the point B . We at first see by this arrangement that the two superior ranges of the face $abdf$ (fig. 19 A), both of them continued between the lines ab , Ah , on one hand, and af , Bh , on the other, remain exposed; which puts in execution the law of decrement by one range of molecules.

The lamina in question is a pentagon resulting from the retrenchment of the three small rhomboids destined to complete it towards the base. This retrenchment is necessary, that the lamina may, by its figure, be accommodated to the effect of the decrement, as we shall presently explain.

The two ranges of rhomboids situated one by one on both sides of the lines Dd' , Ee' , (fig. B) are added, in order that the nucleus may be enveloped, and continue to increase towards the edges bd , fd . (fig. 19 A) which correspond with these lines. These two ranges being sufficient for filling up the vacuum, we perceive that it is not necessary to add similar ones towards the adjacent edges of the laminæ of superposition applied on the adjoining faces. The operation will indicate of itself what is to be done relative to this kind of additions.

Fig. 19 C represents the second lamina of superposition, which ought to be applied on the preceding one in such a way that the points i' , D' , E' , d , may be confounded with those which are marked by the same letters (fig. 19 B). As the crystal ought to assume a new increment towards the edges which correspond with Fd' , Gd' , we conceive that instead of one range added on both sides of the lines Dd' , Ee' , (fig. 19 B) it is necessary to add two (fig. 19 C) on the two sides of the lines Fd' , Gd' .

We shall place successively in the same way the two lamina

minæ represented by figures 19 D and 19 E, observing that the letters marked with an accent, in each figure, ought to coincide with the same letters not accented in the preceding figure.

Beyond the term which answers to fig. 19 E, the laminæ of superposition cease to envelop the inferior edges of the crystal, by their borders (*bords*) analogous to these edges (*arêtes*), and are reduced to simple triangles. This will be easily conceived by considering the laminæ represented by figures 19 F, 19 G, 19 H, the positions of which are determined according to the same conditions with the above.

The number of rhomboids which compose the different laminæ being always diminishing, the last lamina is reduced to a simple rhomboid d' (fig. 19 I), which will attach itself to that denoted by the same letter (fig. 19 H), and will form the summit of one of the lateral solid angles of the secondary rhomboid.

We now see the reason why the laminæ of superposition assume figures successively pentagonal and triangular in issuing from the nucleus. For example, every lamina detached from the crystal (fig. 18) by a section which passes between the angle z and the middle of the lines zt , zu , is necessarily triangular, and has the same structure with $P't'R'$ (fig. 19 G), *i. e.* it is really embattled (*crênelée*) at its basis in such a way, that the imperceptible furrows, which exist on the crystal produced by Nature at the basis of these kind of laminæ, are on the prolongation of those which proceed from the decrement towards the edges. There are even crystals the surface of which, from the effect of a less finished crystallization, exhibits similar furrows, which run over the whole extent of the faces in directions parallel to the small diagonals.

Decrements on the Angles.—The decrements which have ridges (*arêtes*) for parting lines, and which we call *decrements on the borders* (*bords*), would not be sufficient to explain all the diversities of form presented by secondary crystals. Observation and calculation prove that we must also admit of decrements which have angles for points of separation, and the action of which is applied parallel to the diagonals. We shall call them *decrements on the angles*.

In order to enable students to comprehend the method which I have followed in my inquiry into these new decrements, I shall remark, that the same substances which present the dodecahedron with pentagonal planes, originating from the cube, and which might in the same way
assume

assume the form of the dodecahedron with rhombic planes, will also be met with under that of the regular octahedron. Now it appears, on the first general view, that it is possible to refer the structure of this octahedron to a decrement on the edges of a cube; for, if we confine ourselves to decreasing the laminæ of superposition, merely on the edges of two opposite faces of this cube, for example, on those of the superior base $AEOI$ (fig. 20), and of the inferior $A'E'O'I'$, we shall have in general two pyramids placed on these same bases; and if we suppose besides that the faces of each pyramid are prolonged until they meet those of the other pyramid, which does nothing more than continue the effect of the law of decrements in the space situated between the bases of the cube, we shall arrive at an octahedron, the angles of which will vary according as the law shall determine a more or less considerable number of subtracted rows. But theory demonstrates, that there is no law, however complex we may suppose it, which is capable of giving equilateral triangles for the faces of this octahedron.

On the other hand, if we divide a regular octahedron originating from the cube, we perceive that the cubical nucleus is situated in this octahedron, in such a way that each of the six solid angles of the first answers to the centre of one of the faces of the second, which could not take place in the hypothesis of a decrement on the edges. Fig. 20 represents this arrangement; and we may conceive from a simple inspection, that in order to obtain the nucleus, we must successively lay down the six solid angles of the octahedron by perpendicular sections on the axes that pass by these same angles, which would necessarily be parallel to the faces of the cube.

I have concluded from the statement of the position just mentioned, added to the impossibility of here applying theoretical calculation, that the law of decrements has attained its object in these cases, by a route different from that which leads to the forms previously described; and the inquiries relative to this object have developed a new order of facts greatly contributing to the fecundity of crystallization, and at the same time to that of the theory.

Let $OII'O'$ (fig. 21) be one of the faces of the cubical nucleus, subdivided into a multitude of small squares, which shall be the bases of as many molecules. We may consider rows or files of molecules in two different directions, namely, in the direction of the edges, like the row designated by the letters a, n, q, r', s' , &c., or in the direc-

tion

tion of the diagonals, like the rows one of which is designated by $a, b, c, d, e, f, \&c.$; the other by n, t, l, m, p, o, r, s ; a third by $q, v, k, u, x, y, z, \&c.$ See fig. 22, which represents separately one of these ranges or rows.

The molecules of the ranges parallel to the edges touch by one of their faces, and the ranges themselves are simply in juxtaposition. The molecules of the ranges parallel to the diagonals touch by one ridge only, and the rows are as if dovetailed into each other. Now it seems to be well ascertained that the laminæ piled up on the faces of a cubical or other nucleus, also decrease successively in several cases by subtraction of these ranges parallel to the diagonals.

Here the faces produced in virtue of the decrement are no longer simply striated, as in decrements on the edges, but are full of points, which being all on a level, and escaping the eye from their minuteness, present only the aspect of a plain surface.

Now if we imagine that the laminæ which are placed over each other, issuing from the faces of a cube, decrease by a single row on all the angles of these same faces, this decrement will produce the regular octahedron, the mechanical division of which we have explained.

In order the better to comprehend this result, we shall here again adopt the synthetical method, and run over the series of laminæ of superposition, by indicating the auxiliary variations, which they undergo, and which assist the effect of the decrement, to which every thing may be referred.

Let $AEOI$ (fig. 23 A, Pl. IV) be the superior base of the nucleus subdivided into 81 small squares, or facets of molecules. What we are about to say relative to this base may equally be applied to the five other faces of the cube.

Fig. 23 B represents the first lamina of superposition, which should be placed above $AEOI$ (fig. 23 A), in such a manner that the point e' answers to the point e , the point a' to the point a , the point o' to the point o , and the point i' to the point i . We see in the first place by this arrangement, that the squares Ee, Aa, Oo, Ii , (fig. A) remain empty; which is the initial effect of the law of decrement alluded to. We see moreover that the edges QV, PN, LC, FG , (fig. B) exceed by one row the edges EA, EO, OI, IA , (fig. A) as this is necessary that the nucleus may be enveloped towards the same edges, and that the solid may increase as usual in the parts to which the decrement does not extend.

The superior face of the second lamina will be similar to $BKHD$, (fig. 23 C) and it will be necessary to place
this

this lamina above the preceding, in such a manner that the points e'' , a'' , i'' , o'' , may answer to the points e' , a' , i' , o' , (fig. B) leaving the squares empty which have their external angles situated in Q, S, R, P, V, T, M, G, &c., and continuing to effect the decrement by a row. We also see here that the solid increases successively towards the analogous edges at EA, EO, AI, OI, (fig. A) since between B and H, for example, (fig. C) there are thirteen squares, instead of there being only eleven between QV and LC, (fig. B); but as the effect of the decrement confines more and more the surface of the laminæ in the direction of the diagonals, nothing else is wanted than to add towards the unchanging edges a single cube denoted by B, K, H, or D, (fig. C) instead of the five which terminate the preceding lamina, along the lines QV, PN, LC, FG, (fig. B.)

The great faces of the laminæ of superposition which were hitherto octagons QVGFCLNP, (fig. B) having reached the figure of the square BKH D, (fig. C)* will, after passing this point, decrease, so that the following lamina will have for its great superior face, the square B'K'H'D', (fig. D) which is less by one row in every direction than the square BKH D (fig. C); we shall dispose the first above the second, so as to make the points $c'f'h'g'$, (fig. D) answer to the points c, f, h, g , (fig. C.)

Figures E, F, G, H, represent the four laminæ which ought successively to rise above the preceding, with this condition, that the similar letters correspond as above. The last lamina will be reduced to a simple cube denoted by z' , (fig. I) and which ought to rest on that represented by the same letter (fig. H).

It follows from what has been said, that the laminæ of superposition, when applied on the base E A I O, (fig. A) produce, by the assemblage of their decreasing edges, four faces, which, issuing from the points E, A, I, O, are inclined towards each other under the form of a pyramidal summit.

We must now remark that the edges in question have lengths which commence by increasing, as we may observe by inspecting figures B and C, and then proceed to diminish, as we may judge by the following figures. Hence it results that the faces produced by these same edges go on enlarging from their origin to a certain point; and when past this, they begin to contract themselves so as to constitute two

* In the present case, this figure takes place at the second lamina of superposition. On taking a nucleus composed of a greater number of molecules, it is evident that we should have a more remote limit.

triangles joined base to base, or a quadrilater. We see (fig. 24) one of these quadrilater, and in which the inferior angle o is blended with the angle O of the nucleus (fig. 20) and the diagonal tx represents the edge HK (fig. 23 C) of the lamina $BKHD$, which is the most extensive in the direction of this same edge. As the number of the laminæ of superposition producing the triangle tox (fig. 24) is less than that of the laminæ constituting the triangle tox , and as there is here only a single lamina which precedes the lamina $BKHD$, (fig. C) while there are six which follow it as far as the cube z (fig. I) inclusively, the triangle tsx , (fig. 24) composed of the aggregate of the borders of these last laminæ, will be much higher than the inferior triangle tox , as expressed by the figure.

The surface of the secondary solid will therefore be formed of 24 quadrilater, disposed three and three around each solid angle of the nucleus: but as, in decrements by a simple range on all the edges, the faces produced on both sides of each edge are on the same plane; so in decrements by a range on all the angles, the faces which originate in the three sides of each solid angle, such as O (fig. 20), are on a level so as to form but one face: and since the cube has eight solid angles, each composed of three plain angles, the secondary crystals will have eight faces, which, on account of the regularity of the nucleus, will be equilateral triangles, *i. e.* the secondary crystal will be a regular octahedron. One of these triangles is represented at fig. 26, so as to enable us to judge, at a single glance, of the arrangement of the cubes which concur in forming it.

This level of faces produced by subtractions of a range from both sides of the same edge, or around the same solid angle, is a general result of the crystallization which takes place for any primitive form whatever.

The circumstance just considered, and which occurs in muriated soda, sulphuretted iron, sulphuretted lead, &c., affords a new example of a form which, although primitive in certain species, performs in others the function of a secondary one. Theory thus traces the limit that separates objects which the eye would be tempted to confound.

If decrements had not their complete effect, that is to say, if they stopped short of the limit where the faces they produce incline to unite in a point, some faces parallel to those of the nucleus would remain on the secondary crystal. The first would then have fourteen faces, namely, six arranged like those of a cube, and eight situated like those of
a regular

a regular octahedron. Nothing is more common in crystals of sulphuretted iron than this modification, to which we give the name of *cuvo-octahedral sulphuretted iron*.

Here the remark again occurs which we made with respect to decrements on the edges. If we confine our consideration to the immediate effects of decrements on the angles of two opposite faces, for example, on those of the bases $AEOI$, $A'E'O'I'$, (fig. 20) and if we subsequently imagine the eight faces to which these decrements give existence, are prolonged between the bases to the point of intersecting each other, the result will always be a regular octahedron, supposing that the decrements attain their limit.

If the law of these decrements followed a more rapid course, *i. e.* if more than one course was subtracted, then the three trapezoids $stox$, $mtor$, $nrox$, (fig. 25) which would be formed around the same solid angle, would no longer be on a single plane; they would incline towards each other, and the secondary solid would have twenty-four faces which would also be trapezoids, but with angles of a different measure.

The trapezoidal analcime* has a structure of this kind which depends on a decrement by two courses on all the angles of the primitive cube. The form which results is completely similar to that of the trapezoidal garnet; but this resemblance is only exterior, and conceals a primitive form quite different from that of the garnet, this last being the dodecahedron with rhombic planes.

Let us now choose for a primitive form the rhomboid represented by figure 27, which differs from the cube in being a little more acute.

Suppose that the laminae which adhere over all the faces of this rhomboid decrease solely on the angles contiguous to the summits A , O' , and that this decrement takes place by two ranges; then, instead of twenty-four faces no more than six will be formed; and if we conceive them prolonged until they meet, they will compose the surface of a very obtuse rhomboid, which will be the secondary form.

Fig. 28 represents this latter rhomboid with its nucleus. We there see that its summits A , O' are blended with those of the primitive rhomboid, which are the parting limits of the decrements, and that each of its faces, such as $Aeoi$,

* Of *analcime* (*i. e.* impotent) Häuy has discovered only two species, the *A. trapezoidal* and *A. tripointé*; the latter is the *würfel zeolith* of Werner, and cubic zeolite of Brochant.—*Trans.*

corresponds

corresponds with one of the faces A E O I of the nucleus, in such a manner that the diagonal which passes by the points e, i , is parallel to that which goes from E to I, and has merely a more elevated position.

Observation shows that this result is realized by crystallization in a variety of oligiste iron (specular iron ore), which bears the name of *binary oligiste iron*.

The decrements which take place on the angle, whether superior or inferior, are susceptible of several variations, on which it is proper to give some details. I shall attempt to represent these variations by the aid of a graphic method, which will facilitate its comprehension.

Let Gg (fig. 29) be any given rhomboid which has its summits in S and s , let $Sg''sG'$ (fig. 30) be a quadrilateral taken on the oblique diagonals $Sg'', G's$, of two opposite faces, and on the edges SG'', sg'' , comprised between these diagonals. This quadrilateral, which I call the principal section of the rhomboid, is here subdivided into a multitude of similar small quadrilaterals, which represent the principal sections of so many molecules: lastly, let $SGg''G'$ (fig. 31) be the same face as figure 29, subdivided into facets of molecules. If we suppose that the angle g'' undergoes a decrement by a simple course, the small rhomboid which answers to $no g''z$, on the first lamina of superposition, will be subtracted; whence it follows, that the edge of this lamina will have the direction oz , and the distance between the angle g'' , which is the parting line of decrement, and the same edge, will be measured by an oblique demi-diagonal $g''r$ of the molecule.

If the decrement takes place by two courses, in which case the edge of the first lamina of superposition will correspond with cd , the distance in question will be measured by an entire oblique diagonal $g''n$ of the molecule. Thence we shall conclude, that in general, in decrements on the angles, the distance between one lamina and the succeeding, which is the same with that between the point of departure and the edge of the first lamina, is equivalent to as many demi-diagonals of this molecule as there are courses subtracted; whereas, in the decrements on the edges, the distance between two consecutive laminæ contains a number of entire breadths of the molecule equal to the number of courses subtracted.

This being done, let us conceive a decrement by two courses on the angle g'' . In this case the quadrilateral $neap$, (fig. 30) being a segment made on the first lamina of superposition,

perposition*, the decreasing edge of this lamina will coincide with the small edge en , since gn is the same diagonal as fig. 31. Thus if we draw the straight line $g''eh$, it will be found to rest on the face produced by the decrement. Now in this case gh is parallel to the axis Ss , as demonstrated by the help of geometry; whence it follows, that the secondary faces are arranged like the panes of a prism.

If the decrement followed a more rapid progress, as if it took place by four courses, in which case the edge of the first lamina of superposition would coincide with the line yg , then the line $g'qS'$ would indicate the position of the faces produced by the decrement; whence we see that they would rise above those of the nucleus, and would compose the surface of a rhomboid more acute than this nucleus.

If, on the contrary, the decrement took place in height, then the line $ug''s'$, which we suppose to indicate the position of the faces produced, would be thrown towards the inferior part of the axis: hence we conclude, that in this case the faces of the secondary crystal, which would always be a rhomboid, would be found situated in a direction contrary to those of the nucleus, *i. e.* they would be turned towards the edges of the latter.

The hypothesis of a decrement by two courses in height here gives us a remarkable result, which consists in the secondary rhomboid being absolutely similar to the nucleus. We shall see, when speaking of certain varieties of quartz and of tourmaline, that by confining ourselves to the consideration of certain facets taken among those which limit them, and by supposing these facets prolonged until they intersect each other, we should have one of those imitations of the primitive form given by a law of decrement.

Let us pass to the superior angle S , and suppose at first a single course subtracted. If, from the middle t of the oblique diagonal Sp we raise tx parallel and equal to pa , this line will be laid on the edge of the first lamina of superposition, since the distance between the angle S and this edge is equal to an oblique semi-diagonal of the molecule. The line Sxh will therefore be confounded with the face produced, which will be perpendicular to the axis.

A decrement more rapid, such as that which takes place by two courses in breadth, would give faces inclined like

* We take no notice here of the manner in which this segment is terminated in its superior part ap , and only consider the part situated towards the angle g'' .

the line $S a i$: i. e. the secondary crystal would be a rhomboid turned like the nucleus, and more obtuse. This case is that of the binary oligiste iron mentioned above.

Lastly, Can decrement take place in height? In this case the faces produced, one of which is regarded as corresponding to the line $K S m$, will be rejected from the other side of the axis; whence it is easy to see that they will incline towards the edges of the nucleus, in such a manner that the secondary rhomboid will have a position reversed with respect to that of this nucleus.

Crystallization presents some examples of these different results. Those which relate to the two limits given by parallel positions, or perpendicular to the axis, are constant, *i. e.* they take place with respect to all possible primitive rhomboids. In the other cases the inclination of the faces produced by the same decrement varies according to the angles of the primitive rhomboid.

The striæ and striges on the faces of secondary crystals, when the operations of nature have not attained the perfection of which they are capable, frequently indicate, by their directions, those which follow the edges of the laminæ of superposition; and these accidents, which confirm the theory in bodies capable of mechanical division, may also show the progress of crystallization, and the direction of the component laminæ in those which are incapable of mechanical division, and assist us in catching by analogy the form and position of the nucleus, which otherwise might escape observation. We should, however, use with caution the indications furnished by these accidents, since it sometimes happens that the surface of the nucleus itself is striated. This singularity seems to be the effect of an imperfect decrement, which experiences such great interruptions, that the faces resulting from it sensibly coincide with the primitive faces. In like manner, it is not impossible that the faces of a secondary crystal may have striæ in a direction different from that which ought to result from the progress of the decrements. But there are cases, such as those of certain garnets with 24 trapezoids, in which the striæ are so palpable as to show plainly the mechanism of the structure.

[To be continued.]

XXXI. *Proceedings of Learned Societies.*PROCEEDINGS OF THE FRENCH NATIONAL INSTITUTE
FOR THE YEAR 1808.

THE Institute held its anniversary on the 2d of January 1809; the following being the order of their proceedings.

1st. Proclamation of the questions proposed, and prizes adjudged by the class. 2d. Historical eulogy on M. Lassois, by M. Cuvier, perpetual secretary. 3d. Memoir on the navigation of the ancients, by M. Buache. 4th. Historical eulogy on M. Berthoud, by M. Delambre, perpetual secretary. 5th. Memoir on the levelling of plains by means of the barometer, by M. Ramond. 6th. Historical eulogium on M. Ventenat, by M. Cuvier, perpetual secretary. 7th. Memoir on the means of facilitating the victualling of fleets in Brest roads by navigable canals, by M. Rochon.

The Class of Sciences had proposed as the subject of a prize, to be awarded on the present occasion, "The theory of the perturbations of the planet Pallas," discovered by M. Olbers, or in general the theory of the planets, the eccentricity and inclination of which are too considerable to admit of our calculating the perturbations with sufficient exactness by the methods at present known. In order to confine ourselves on so difficult a subject to what is indispensable, analytical formulæ only are requisite, but arranged in such a manner that an intelligent calculator may apply them with certainty, either to the planet Pallas, or to any other subsequent discovery.—The class has received no memoir; and if we reflect on the difficulty of the problem, it will not appear astonishing. But as the question proposed is of the greatest interest with respect to the general theory of planetary perturbations, and as it is to be presumed that leisure more than good will is wanting to geometers capable of treating this question, the class has thought proper to renew the subject for the prize to be decided in January 1811. The prize has been doubled; being a medal of the value of 6000 francs. The papers on the subject will not be received after the 1st of October 1810.

The natural history of animals has lately received from comparative anatomy some valuable additional lights, which have wonderfully improved the science of zoölogy, particularly from the description of the principal organs in several families, the œconomy of which was almost entirely unknown in the middle of the last century. The Institute

thinks to perform a service to the cause of science by pointing out to anatomists the orders or genera respecting which it is important to be in possession of further information, and with this view has chosen the following as the prize question: "Ascertain if there exists a circulation in the animals known by the name of *asteriæ*, or sea stars; *echini*, or sea hedgehogs; and *holothuriæ*, or sea priapi: and in the event of a circulation existing, describe its progress and the organs connected with it."

This description will probably be accompanied with observations made on living animals, and take a view of the vessels of the organs of respiration, if there are peculiar organs of this description, as well as those of the great circulation. It would also be proper to examine the chemical effect of respiration on air and water. This is not an indispensable requisite, however. The examination of one species only in each of the three families is expected; but it is requisite that it should be profound, and accompanied by intelligible drawings. The prize offered is 3000 francs, and the competitors must give in their memoirs on or before the 1st of October 1810. The prize will be publicly awarded on the first Monday in January.

A prize had been last year offered for an investigation of the causes of the various kinds of phosphorescence; but so many memoirs were transmitted on the subject, and they were so full of experiments, that the committee appointed to decide on their merits have postponed delivering their opinion.

M. de Lalande, on offering a medal to the author of the newest and most curious observation, was well aware that it could not be awarded every year to discoveries so brilliant as those of the planets perceived by Messrs. Piazzi, Olbers, and Harding: he has therefore desired, that when there were no observations of so much interest, the medal should be given to the author of the best memoir on any astronomical subject; and if there should be no such memoir, he expressed a wish that the recompense in question should be granted to any pupil who has demonstrated zeal, constancy, and perseverance, in the study of astronomy.

The Institute, to whose lot it has not fallen this year to commemorate a newly-discovered planet, or to reward a memoir of any interest, has profited by bestowing the medal as an encouragement.

MM. Arago and Mathieu were the two astronomers who were considered as having the best claims to this gratuity.

The former had been long employed as assistant to
M. Bouvard

M. Bouvard in the Imperial Observatory, and was sent with M. Biot to Spain, where, by himself and in conjunction with that gentleman, he measured the altitude of the pole, the azimuth, the length of the pendulum, some grand triangles, and executed successfully the most delicate operations of astronomy.

M. Arago, having been made prisoner in the course of his travels, escaped from Majorca, and took refuge in Algiers, but was again taken in a Spanish vessel, when returning to France in an Algerine sloop, and carried prisoner to Palamos, near Rosas, from which place we hope he will be relieved by the victorious French arms.

M. Mathieu, who supplied M. Arago's place in the Observatory when the latter went to Spain, and who afterwards, when sent to Bourdeaux, Figeac, and Clermont, measured at these three stations, in company with M. Biot, the length of the pendulum, is now occupied at Dunkirk in similar operations.

In deciding on the claims of these two gentlemen, the Institute reflected that M. Arago had recently received a more lasting recompense for his services in being appointed to the Board of Longitude. The medal has therefore been adjudged to M. Mathieu, as an encouragement to proceed with his scientific labours.

Analysis of the Labours of the Class of Mathematical and Physical Sciences. By M. DELAMBRE.

The history of the Class of Mathematical Sciences this year affords a remarkable circumstance,—one of the most difficult and important points of the mundane system treated with the same success, although by very different methods, by two geometers of the first rank, who arrive by various routes at the same conclusion,—a circumstance not less worthy of attention: the idea of this labour occurred to them on the occasion of a memoir not less interesting, read to the class by a young geometer, who, in the first steps of his career, has proved himself a fit associate for his superiors in years.

These mutual succours afforded by men of science to each other, which produce others not less fortunate and frequently easier, are advantages peculiar to the mathematical sciences over general literature. In the former branch of literature a new truth, an elegant theorem, is like a lighthouse, which exhibits its lustre at a distance, and renders practicable, routes which were thought impervious.

In order to give an idea of the three memoirs which we are about to mention, it is necessary to recur to a remote æra in the history of science.

Astronomers had remarked a sensible acceleration in the course of the moon: the other planets and the earth might consequently have a similar although less rapid acceleration in their motions. This question may perhaps appear indifferent to those who are not aware of its consequences. If the earth be accelerated, it must be owing to its closer approach to the centre of motion; and if so, will it not end by being precipitated on the sun? This danger to be sure is far distant. If this acceleration existed, it would be prodigiously slow, and it would not be until after an almost infinite number of centuries that the catastrophe could happen, supposing it to be possible; for it is proved by the example of the moon, that the acceleration only lasts a certain time, and afterwards becomes slower: but although future generations have nothing to fear from this event, and if the planet, after coming closer to the sun, afterwards removes from it, it must nevertheless be confessed that the question is not less important: it peculiarly interests those astronomers who suppose, in all their calculations, an invariability of the ellipses described by the planets.

M. La Place was the first who examined this question. By a learned but simply approximative calculation he attained this result, ascertaining that the axes and mean movements are in reality invariable, at least when we consider them as the first powers of the masses only, and the second of the eccentricities and inclinations; which is already sufficient for tranquillizing astronomers with regard to the fate of our planet, or rather with regard to their tables.

M. Lagrange, struck with this conclusion, endeavoured to extend it; and by a curious theorem he proved the proposition to be correct, even on considering all the successive powers of the eccentricities; but, in common with M. La Place, he had only considered in the masses the terms of a single dimension.

Could the terms of the two dimensions produce an acceleration? It would, indeed, be much slower: but the question deserved examination, and this was undertaken by M. Poisson. The calculation was uninviting on account of its length; it required all the resources of analysis, and the knowledge of all the laws of the celestial motions: it required a peculiar degree of attention, and a penetrating eye, which at the first glance should be able to perceive all the forms that could be assumed by a complex expression,

sion, and a mind capable of devising a shorter and more certain road.

Such are the qualifications which M. Poisson has displayed. By these means he has attained the interesting theorem, that the products of the two dimensions of the masses do not furnish, in the successive integrations, any term which gives a secular equation or an acceleration in motion. This is enough even for astronomers; it is demonstrated that, if this acceleration exists, it can only depend on terms of 4, 6, and 8, *i. e.* absolutely insensible dimensions; which assures us of the stability of the planetary system. The question at present therefore offers no real interest, if there be not an analytical difficulty to overcome, which is still sufficient to excite the emulation of geometricians.

M. Poisson, in order to obtain his theorem, had only pushed the approximation to the terms affected of the squares, or of the products of the masses: having regard to the variation of the elements which M. Lagrange had regarded as constant, he knew how to give to the terms which form the second approximation, a disposition which admitted of demonstrating that none of these terms can give to the grand axis a term proportional to the time. The terms which ought to proceed from the variations of the elements of the perturbing planets escaped this analysis; but, by ingenious methods founded on a method of M. La Place, M. Poisson has proved that these kinds of terms cannot produce in the grand axis any variation which increases as the time does.

In geometry in particular, the route by which we attain for the first time a difficult discovery is rarely the shortest and most direct. There are propositions the truth of which is apparent without our being able to demonstrate it: men of science dread to involve themselves in immense calculations, the success of which is problematical, and sometimes give up an inquiry which presents too many difficulties. But if the truth has been ascertained, as success is from that moment certain, we take courage, and demonstrations are simplified and multiplied: this is precisely what has happened. The instant M. Poisson had demonstrated his theorem, Messrs. Lagrange and La Place perceived that it flowed out of principles and methods which had been formerly explained. M. Poisson attained his discovery by a calculation in which he made use of the known formulæ of the elliptic motion; M. Lagrange thought that it ought to

have been attained by the power of analysis, even without knowing the peculiar expressions of the quantities relative to the elliptic orbit.

In this manner he demonstrates, in its whole possible generality, and whatever may be the inclination of the primitive orbit, *that the variation of the great axis cannot contain any term not periodical, either in the first or the second approximation, at least while regard is had in the latter only to the variations of the elements of the disturbed orbit.* This prevents the same analysis from being also extended to the terms proceeding from the elements of the perturbing planets: it is because in this case the function is not symmetrical with respect to the co-ordinates of all the planets.

But by carrying the planets, not to the centre of the sun, but to the centre of gravity of the sun, and of the planets around which the motion is more regular than around the sun, M. Lagrange obtains a symmetrical function, which is the same with respect to all the planets: the calculation then becomes uniform, and is not subject to any exception; and we demonstrate by one and the same analysis, that the great axis of each of the orbits cannot have, in the two first approximations, any inequality increasing with the time.

It is afterwards easy to pass from the motion around the common centre of gravity to the motion around the sun; and we at length succeed in demonstrating the general proposition of the non-existence of the inequalities proportional to the time in the great axes of the planets referred to the sun.

To return to the memoir of M. Lagrange: we there find his new formulæ for the variations of the elements of the planets, as well as their application to the variations of the grand axes. His analysis is worthy of the attention of geometers from its uniformity, generality, and elegance, and because it is independent of the elliptic figure of the orbits, and may be applied with the same success to every other hypothesis of gravitation, in which the orbits would no longer be conic sections.

The whole of this analysis is preceded by a historical detail of this great problem, drawn up with all possible clearness, in such a manner as to interest even those who should not have all the knowledge necessary for following the author into the whole details of his theory.

In this memoir, read to the class on the 22d of August, the generality of the analysis permitted M. Lagrange to
express

express certain values by the symbols of functions : it was useless for him to give developments which rendered the demonstration less clear and more difficult : but in order to apply his formulæ to the numerical calculation of the planetary perturbations, these developments became indispensable. In a supplement read to the class on the 2d of September, M. Lagrange gave these calculations ; but he knew admirably well how to abridge them by the consideration of the eccentric anomaly ; and in order to demonstrate the exactitude of this new process, he showed that it led to the same formulæ which he had obtained by another way. These substitutions, which should seem to have been very complicated, admit of astonishing simplifications, by means of several equations of condition which M. Lagrange has drawn from his theory.

Before reading this memoir to the Class of Sciences, M. Lagrange had communicated it to the Board of Longitude on the same day on which M. La Place detailed the method by which he attained the same results.

The object of M. La Place in this work, which he has printed separately, was the perfection of the methods he had given in the *Mécanique Céleste*. On endeavouring to give to the expressions of the elements of the orbits, the simplest form of which they are susceptible, he succeeded in making them depend only on partial differentials of one and the same function ; and what is remarkable, the coefficients of these differences are only the function of the elements themselves ; an advantage also enjoyed by the formulæ of M. Lagrange, who had long ago given the example in the expression which he had found for the great axis,—an expression which had led him to demonstrate, in a very fortunate manner, the invariability of the mean motions, when we have regard only to the first power of the perturbing masses. M. La Place has subsequently given the same form to the differential expressions of the eccentricity of the orbit, the inclination and the longitude of the node. It still remained to transform in the same way the differential expressions of the longitudes of the epoch and of the perihelion. This is what M. La Place executes in the supplement of which we now give an account ; and thereby the finite variations of the differentials flow from the development of a very simple function, which performs an important part in the *Mécanique Céleste*. These new expressions lead very naturally to the elegant theorem of M. Poisson on the invariability of mean motions ; they lead also to the most simple and general solution of the secular variations of the elements

elements of the planetary orbits; they give with the same facility the two inequalities of the lunar motion in longitude and latitude, which depend on the flattening of the earth, formerly determined by M. La Place.

The results are therefore perfectly identical with those found by M. Lagrange by a totally different way. They would be mutually confirmed if occasion required, and if the two methods did not carry their demonstration along with them. The most remarkable difference consists in M. La Place having adroitly avoided a very great analytical difficulty, and capable of impeding the progress of a less eminent geometrician; while on the other hand M. Lagrange has overcome the difficulty; and by giving, like M. La Place, the theorem, so important to astronomers, of the invariability of motions, he has furnished analysts at the same time with formulæ remarkable for their elegance. But it is not less curious to observe with what facility, by a simple transformation, M. La Place has elicited these new truths from the formulæ in which they were contained.

The secretary of the Institute then proceeded to give a detailed account of the works composed during the year 1808 by members of the class.

PHYSICS.—At the commencement of the year the class had the honour to present to the emperor the History of the Sciences since the year 1789, which his majesty ordered to be printed. The editors of this work, in profiting by the materials furnished by members of the class, and by foreigners, have endeavoured to trace, with truth and simplicity, the immense progress which the human mind has made in the knowledge of nature during these twenty years, when war, intestine dissensions, and extravagant passions, which alternately visited all states and empires, seemed to have interrupted all useful inquiries and discoveries.

This historical sketch will now serve as our point of departure, and our annual reports in future will be so many continuations.

We ought, it is true, in our analyses, to treat only of the subjects which have been discussed at our meetings: but in the active relations in which we find ourselves with the majority of those who cultivate the sciences, it is very unlikely that any important discovery will be made throughout Europe, which will not speedily be heard of within the walls of the Institute, and excite its members to similar pursuits.

Chemistry, in the decomposition of the alkalis, has this year presented a striking example of the emulation which
animates

animates the learned of various countries. Scarcely had we been apprized in France of the discovery of Davy, on the changes which potash and soda undergo by the action of the Voltaic pile, when two of our young chemists, M. Gay Lussac, member of the class, and M. Thenard, professor in the college of France, endeavoured to produce the same effect by the common affinities, and succeeded by means of apparatus most ingeniously contrived*.

The public journals having announced that laminated zinc had been applied to several useful purposes in England, it is but justice in us to reclaim this application of laminated zinc as a French improvement. M. Macquer and M. Sage long ago performed this process by heating the metal: but we have to notice another recent improvement on this subject in France, namely, the art of converting, by simple sublimation, calamine or oxide of zinc into metal sufficiently pure to undergo lamination. Messrs. Donq and Poncellet have, in the department of the Ourthe, lately succeeded in this operation, and the ore furnished them with one-third of its weight in metal. This laminated zinc may be employed on almost all occasions, instead of sheet lead, and it will be found much cheaper.

Another application of chemistry, not less interesting to society, is the art of preparing with wood an acetic acid equally pure with radical vinegar. This was suggested by Messrs. Fourcroy and Vauquelin, who discovered that the acid which goes by the name of *pyro-ligneous*, and is produced by the distillation of wood, is only the acetic acid mixed with some foreign substances. On freeing it from these, M. Mollerat has procured an acid which may be used as a substitute for common vinegar; but it is more acid than the latter.

The interruption of our colonial intercourse has repeatedly suggested the employment of some substitute for sugar, and M. Parmentier has recently published some popular instructions on the art of extracting from the must or juice of the grape, a syrup, in order to supply the place of sugar: he has presented some excellent specimens of this syrup to the Institute, and great quantities of it are now manufactured in our southern provinces: the interruption to the exportation of our wines is an additional encouragement to this manufacture. The grapes of the south of France, being naturally sweeter, give proportionally more sugar; and care

* See Philosophical Magazine, vol. xxxii.

must be taken to free the must from a more or less considerable quantity of tartar or other acids, which is effected by means of lixiviated ashes. This operation constitutes the essence of M. Parmentier's discovery.

To return to chemistry in general: it will be recollected that some time ago M. Morveau endeavoured to find an instrument for measuring the highest degrees of heat, and of which we have from time to time given an account. In the present year M. Morveau read to the class a complete history of the attempts previously made by chemists and manufacturers on this subject; he has appreciated the methods resorted to by Newton, Muschenbroeck, Mortimer, and particularly Wedgwood, to whom he does more justice than has hitherto been done in France. He has even given an account of the experiments on the dilatibility of the metals, made by watch-makers and others with a view of constructing compensation pendulums: lastly, he has described an instrument of his own invention, sufficiently delicate for showing the minutest changes in length of a small metallic bar. In short, it is only such a bar, particularly when made of platina, that can be at once sufficiently dilatible and unalterable in the fire to be used as a pyrometer; but the greatest difficulty is to place it on a scale which does not dilate,—otherwise we could never ascertain the variations. This is what M. Morveau expects to attain, and to which he continues to direct his attention.

M. Gay Lussac has recently developed an elegant law of general chemistry, on the proportion of metal which enters into each metallic salt, and on that of the oxygen necessary for its oxidation. He has proved that the metal which precipitates another metal from an acid solution, finds in the precipitated metal all the oxygen necessary for being oxidated, and dissolved in such a quantity that the solution is neutralized to the same degree. The quantity of oxygen remains therefore constant, whatever be the quantity necessary of each metal: the acid is therefore in each salt in proportion to the oxygen of the oxide, and there must be so much the more of each metal for saturating, the less occasion this metal has for oxygen in order to be oxidated. This law gives a very simple method of determining the composition of all the metallic salts; for it is sufficient to be acquainted with the proportion of the acid in a salt of any kind, in order to know it in them all, and a single analysis dispenses with all the rest. It is always pleasing to find an increase of simple methods for attaining precision in
the

the experimental, and to recur to the mathematical sciences.

M. Darcet jun., has applied these rigorous methods to the analysis of the alkalis, and has proved that potash and soda, when prepared with alcohol, and heated until they begin to evaporate, still return nearly one-third of their weight in water.

[To be continued.]

XXXII. *Intelligence and Miscellaneous Articles.*

DR. HERSCHEL.

IN our last Number, page 158, we inserted a table of rules for predicting the weather, and which had been for some time circulating in MS. as the production of Dr. Herschel. That gentleman having publicly disclaimed the table alluded to, we consider it as a duty due to him and to our readers to insert the following disavowal:

*Notice to the Public from WILLIAM HERSCHEL, LL.D.,
of Slough, near Windsor.*

MANY of the public papers, for a length of time past, have occasionally ascribed certain predictions of the state of the weather to me; and several of them have lately gone so far as actually to prefix my name to what they have called a Weather Table, in which, according to certain hours of the changes of the moon, wind, rain, snow, frost, &c. &c., are prognosticated. Such a table, by some mistake, has even been very lately inserted into a very respectable Philosophical Magazine. In justice to myself, therefore, I think it highly necessary that the public should be undeceived by my declaring that the table pretended to be of my construction, as well as every prognostication of the state of the weather that has appeared in the Newspapers as ascribed to me, are all gross impositions.

WILLIAM HERSCHEL.

Slough, near Windsor,
Sept. 16, 1809.

CITY PHILOSOPHICAL SOCIETY.

A society under the above name has for some months been established, for the purposes of philosophical discussions and experiments. The evenings of meeting are every Wednesday; and a lecture is delivered every second Wednesday by the members in rotation. The lectures are very well attended. They embrace Chemistry, Natural and Experimental

Experimental Philosophy, Anatomy, History, and other branches of Science.

LECTURES.

St. George's Hospital, and George Street, Hanover Square.

On Saturday October 9th, a Course of Lectures on-Physic and Chemistry will recommence in George Street, at the usual Morning Hours, viz., the Therapeutics at Eight; the Practice of Physic at half after Eight; and the Chemistry at a quarter after Nine, by George Pearson, M.D. F.R.S., Senior Physician to St. George's Hospital, of the College of Physicians, &c.—Clinical Lectures are given as usual on the Patients in St. George's Hospital every Saturday Morning at Nine o'Clock.

LIST OF PATENTS FOR NEW INVENTIONS.

To William Hutton, of Sheffield, in the county of York, merchant, for his method of making sickles and reaping-hooks, with iron in steel backs fixed upon the blades thereof, whether such blades be forged, rolled, cast, hammered, or otherwise manufactured.—July 31, 1809.

To Frederic Albert Winsor, of Pall Mall, in the county of Middlesex, esq., for his fixed telegraphic light-house, and also a moveable telegraphic light-house for signals and intelligence to serve by night and by day, in rain, storm, and darkness, in any required direction, and from any given centre.—August 3.

To Ferdinand Smyth Stuart, of Billericay, in the county of Essex, esq., for his substitute, the produce of this country, for Peruvian bark.—August 4.

To Thomas Dickin, of Abrewase Mills, in the county of Stafford, cotton-manufacturer, and Henry Bradley of the same place, cotton-spinner, for a new method of preparing hemp, flax, hurds, short tow, and clearings, and other inferior parts of hemp and flax, either alone or mixed with cotton wool, for the purpose of spinning the same into yarn or thread; and also certain improvements in the mode of spinning the same.—August 8.

To Edward Law, of Shelton, in the parish of Stoke-upon-Trent, in the county of Stafford, schoolmaster, for an improved rotative engine, or machine, to be worked by the power of steam, for raising water, grinding corn, and various other useful purposes.—August 9.

To John Hives, of Holbeck, in the parish of Leeds, in the county of York, linen-manufacturer, for a machine for hackling or dressing hemp, flax, and other materials.—August 12.

Isaac Kellogg, late of Connecticut, in North America, but at present residing in Addle Street, in the city of London, gent., (assisted by, and in conjunction with, his brother Friend Bissell Kellogg, residing in North America,) has invented an improved machine for shearing woollen and other cloths, for which a patent has been granted, dated August 21.

To Samuel Long, of the town of Leicester, in the county of Leicester, gent., for improvements on horizontal wind-mills.—September 4.

To Joseph Bramah, of Pimlico, in the county of Middlesex, engineer, for a new method of making and constructing pens for writing.—September 23.

To George Vaughan, of Purim Place, Whitechapel Road, Middlesex, gent., for improvements in the process of refining sugars.—September 25.

To Rodolph Tschiffeli de Roche, of Great Pulteney Street, Middlesex, gent., for improvements in the processes of brewing.—September 26.

To Egerton Smith, of Liverpool, in the county of Lancaster, optician, and Michael Harris, of the same place, mechanic, for improvements in ships' binnacles and compasses, and in the mode of lighting the same.—Sept. 26.

To John Penwarne, of the parish of St. Pancras, Middlesex, gent., for his method or process by means of which he is enabled to give to statues and other ornamental works in plaster (commonly called plaster of Paris), an appearance nearly resembling the finest statuary marble, at the same time rendering them more hard and durable, less liable to be soiled, and easier to be cleaned.—Sept. 26.

To William Watts, late of Castle Knock, in the county of Dublin, now of the city of Bath, gent., for new methods of combining and disposing machinery, and applying the different powers of wind, water, and cattle, thereto, so as to effect improvements on mills.—Sept. 26.

To Benjamin Flight, of Saint Martin's Lane, Middlesex, organ-builder, for his new metal nave axle and box for wheeled carriages, by means of which the danger of overturning, and the concussion arising from carriages coming in contact at the nave, are considerably lessened, the nave much stronger, and gives more lightness of appearance to the carriages than those now in general use; the rattling of the carriage in action is also lessened; the oiling of the wheels, which need not be taken off for that purpose, is performed with greater ease and facility, and the oil is effectually prevented from communicating to the spoke of the wheels.—September 26.

METEOROLOGICAL TABLE,
 BY MR. CAREY, OF THE STRAND,
 For September 1809.

Days of the Month.	Thermometer.			Height of the Barom. Inches.	Degrees of Dryness by Leslie's Hygrometer.	Weather.
	8 o'Clock, Morning.	Noon.	11 o'Clock, Night.			
Aug. 27	55°	64°	55°	29.76	26	Showery
28	56	66	60	30.04	72	Fair
29	60	72	63	.08	76	Fair
30	65	76	66	29.85	32	Fair
31	60	66	59	.85	19	Cloudy
Sept. 1	60	63	56	.80	20	Cloudy
2	60	70	57	.65	32	Fair
3	61	72	61	.62	44	Showery
4	63	69	61	.60	18	Stormy
5	61	70	60	.54	31	Fair
6	60	70	61	.52	35	Fair
7	60	66	56	.29	29	Showery
8	55	61	55	.42	20	Showery
9	55	66	54	.65	52	Fair
10	54	64	53	.67	15	Showery
11	54	63	52	.72	52	Fair
12	53	64	49	.80	46	Fair
13	49	62	56	.84	28	Showery
14	57	62	56	.69	21	Showery
15	56	65	52	30.05	48	Fair
16	51	64	60	.10	18	Cloudy
17	56	65	55	.01	31	Cloudy
18	58	64	58	29.80	10	Rain
19	54	62	50	.75	60	Fair
20	53	66	55	.36	41	Rain
21	52	64	55	.80	55	Fair
22	54	69	57	.68	47	Showery
23	63	65	54	.70	52	Showery
24	53	58	48	.85	25	Showery
25	56	49	45	.74	0	Rain
26	43			30.00	51	Fair

N. B. The Barometer's height is taken at one o'clock.

XXXIII. *On the Date of the Application of Telescopes to astronomic Instruments; the Time when Astronomers first observed the Stars and Planets in the Day-time by means of these Telescopes; and on the Author of these Discoveries. Translated from the French of M. DE FOUCHY*.*

THE two discoveries which form the object of this memoir are among those that have contributed most to bring astronomy to its present degree of perfection. It is very singular that the gratitude of astronomers has not preserved to posterity the person's name who made them; and that the Academy has now, at the end of a century, this omission to repair;—happily it is never too late to render justice: honour and gratitude do not admit of prescription.

It was required last year to point out the author of the application of telescopes instead of sights to instruments; to determine the date of this invention; and the time when astronomers first observed the planets and largest stars by means of them during the day-time. The greater part of astronomers attributed one of these two useful inventions to M. Auzout, and the other to M. Picard. As I remembered to have seen these two points very well established somewhere in a book I had formerly read, I merely observed, that I supposed the time might be obtained very nearly; and the Academy requested me to endeavour to find what I could on this subject:—The following is the result of my research.

The late M. de la Hire† gave in 1717 a memoir entitled *Inquiries, respecting the Dates of the Invention of the Micrometer, of Pendulum Clocks, and of common Telescopes.* As I knew that he had spoken in this memoir of some other astronomic inventions, I wished to see if he had not mentioned this. I found that he could neither discover the exact time nor the name of the author of this invention; that he spoke of it to M. Picard, who merely told him that M. Auzout had some concern in it; which agrees very well with what Picard said himself at the beginning of his *Treatise on the Measure of the Earth*,—*that the idea of applying telescopes instead of sights to instruments, had been thought of for some time.* M. de la Hire adds also, that he had searched the *Philosophical Transactions* without having found any thing relating to the purpose. I therefore took

* Read to the Royal Academy of Sciences at Paris, 12th of November, 1783, and published in the *Memoirs* for 1787.

† *Memoirs* for 1717, page 78.

the trouble to trace back my steps. I endeavoured to remember where I had seen these points discussed, and I recollected at length, that it was in Morin's *Science des Longitudes*.

In the celebrated conference which he had on this subject, the 30th of March 1634, with the commissioners named by cardinal Richlieu, Morin (when answering to the objection against the size of the instruments, which did not permit them to be used at sea,) among a number of methods which he used to preserve their accuracy whilst diminishing their radius, mentioned the application of telescopes to the index, instead of sights. These are his words:—"The third method is the application which I have found means of making of a telescope to the index instead of sights, to measure more readily and more exactly the distance of the moon from the stars*." For in the method he used of deriving the longitude from the observed distance of the moon from the stars, Morin had found that he could not expect sufficient truth in the collimation, for a star to traverse the sights; and he therefore thought of using telescopes, which had not then been invented more than about 25 years.

He had for this purpose placed a telescope on the index of his instruments: he then saw the stars with the greatest clearness; but it became necessary to determine the point in the field of view of the telescope, on which to place the star, so that the line passing through the optic centre of the object-glass might then be parallel to the fiducial line of the index. Morin had but one step further to proceed in order to derive all possible utility from his invention, by applying cross wires in the common focus of the two lenses †: but I know not by what fatality it happens, that the most simple means are commonly the last to present themselves. He took another, less accurate method, which brought with it an inconvenience: he thought of covering the eye glass with a thin disc of copper or iron, pierced in its middle with a small hole. By this means he obtained indeed a part of what he desired: for it is certain, that the star once seen in the centre of the small hole was very nearly in a constant line, which might be made parallel to the fiducial line of the index. We say *nearly*; for, however

* *Astronomia jam à fundamentis integrè et exactè restituta, complectens 9 partes hactenus optatæ scientiæ longitudinum, &c.,* autore J. B. Morino, 1640, in 4to, pars i. page 18. This date in the frontispiece is later than that of the first publication, which was in 1634.

† It was Huygens who thought of this method—*Systema Saturnium*, 1659.

small we suppose the hole at the centre of the plate to be, we should always be troubled to ascertain with certainty whether the star occupied the centre precisely ; and however little the eye might be moved, the star would appear also to change its place ; which could not but diminish the accuracy of the operation. But there was a much greater inconvenience : it became very difficult to find the star ; and frequently the instant of time in which the observation was to have been made was passed before it could be found in the telescope. Morin remedied it in the following manner :—

He had put on the object-end of his telescope *, a sight cut in the middle with a slit sufficiently wide answering to the diameter of the field of the telescope : when he wished to observe a star, he placed it above this slit, and conducted it just over the tube ; he was certain then of finding it in the telescope, and of being able to place it in the middle of the small hole of the plate.

Such was the method which Morin pursued in his researches : it therefore follows that he is the first who adapted telescopes to instruments instead of sights : but that the kind of eye-hole with which he covered the eye-glass was neither so convenient nor so exact as the cross wires put in the common focus of the two glasses by M. Auzout about the year 1667 ; and Morin did not doubt that his invention would afterwards be improved. Let us hear him do justice to himself in this respect.

He says †, “ I do not doubt but they may add to what I have invented some ingenious means which will render its use more exact and more easy. I even desire it very sincerely ; and am ready to give those who shall effect it the just praises which they will merit ; contenting myself with having opened to minds more subtle than mine, roads which were hitherto unexplored.” An author who speaks with so much modesty of his own work deserves to be favourably heard.

I have not been able to determine the precise date of this invention of Morin ; but there is great probability that it preceded a little the celebrated discussion of the 30th of March 1634. I shall be more precise as to the time when they began to observe the stars and planets in the day-time by means of telescopes. Morin has preserved its history : and this part of his book is written with a lightness and a

* *Scien. Longit.* pars i. p. 55.

† *Ibid.* pars i. p. 56.

poetic style, which we could not expect from his pen nor from the subject. I shall do little else than translate it, and the following is the way in which he explains himself*.

“ One night, about the end of March 1635, I amused myself with my telescope, and was considering Jupiter and his satellites, musing profoundly, and thinking what might be the use to which these small planets were destined, when, all at once, a celestial messenger came on wing, presented himself to me, and held this discourse: ‘ Why fatiguest thou thine eyes uselessly in observing the moon, the sun, and Jupiter, with this instrument? Leave this amusement to others, and apply thyself to things more useful, and to which thou art destined: if thou followest my advice, a far greater glory is reserved for thee, since thou shalt see in broad day-light the planets and the principal stars, which no mortal has hitherto been able to perceive unless during the night: this will give thee the most certain means of establishing the principal elements of astronomy:’ and after having said these few words to me he disappeared. His discourse could not be effaced from my memory, and I had no more rest until I had found by what means I might see the planets and bright stars during the day-time; and I applied with so much more ardour, as I remembered, under some particular circumstances, to have seen Venus with the naked eye whilst the sun was very high above the horizon. This is the method I pursued.

“ I affixed a telescope of a foot and a half to the index of one of my instruments, which served it as a support; and I placed this apparatus in the western window of my room, in order that the brightness of the rising sun might not dazzle me. Some time before day-light, whilst the bright stars were yet visible, I put Arcturus in my telescope, and kept it there almost until the rising of the sun; remarking with pleasure, that I yet saw it distinctly in the telescope, a long time after the brightness of the day made it disappear to the naked eye: a cloud covered it at this moment, and when it was passed, I could not with every endeavour find it again. This accident distressed me; but I was patient, well knowing that had it not been for this cloud, I should have been able to have seen the star much longer. Next morning before day-light, the sky being very clear, I got Arcturus in my telescope, and kept it there until I saw the light of the rising sun enlightening

* *Scien. Longit. pars vi. p. 210 & seq.*

the objects in the west. I was so overjoyed that I thought of reversing the telescope and the instrument: but this first emotion being appeased, I continued my operation more than half an hour after the sun had risen: the light then increasing, the star gradually diminished, and at length disappeared.

“The following day Venus being in Aquarius, and rising before the sun, I brought her in the field of view of my telescope; and although she was then in her increase, and consequently less luminous, I preserved her there more easily than Arcturus for an hour and more after the sun had risen. I have made the same observations with all the other planets and the larger stars.” All this appears to have lasted only about four or five days, and must be referred to the end of March 1635.

Such is the account which Morin gives of this discovery, with which he was affected to a degree of enthusiasm. If he had used a longer telescope, he would have been able to observe the planets and large stars not only by day-light, but even at noon-day. However, I do not believe that we can dispute with him the honour of having first observed the planets and principal stars during the sun’s presence,—an immense advantage to astronomy, and which gives him an undoubted and well-earned right to the gratitude of astronomers.

After what we have said, can it be believed, that in 1669, more than 33 years after the publication of Morin’s work, the Abbé Picard should assert himself to be the author of this discovery? The following is the passage from the History of the Academy*, by M. de Fontenelle: “The 3d of May of this year (1669), M. Picard was much surprised to be able to observe the meridian altitude of Regulus near 13 minutes before the setting of the sun: astronomers have hitherto not only been unable to observe the fixed stars in the day-time, but, it is believed, not even during twilight. M. Picard went further: on the 13th of July he observed the meridian altitude of Arcturus, the sun being then elevated nearly 17 degrees.” We find nearly the same in Du Hamel’s Latin History, page 54.

How did it happen that Picard was ignorant that towards the end of March 1635, more than 34 years before his observation, Morin had made this fine discovery; and that he had published it in 1635, in his *Science of Longitudes*? † I should be extremely sorry if this article, which

* Tome i. p. 109 & 110. † Pars vi. p. 210 & seq.

the cause of truth alone obliges me to relate in this memoir, should cast the least suspicion of plagiarism on the memory of M. l'Abbé Picard. Whatever we have of his shows him to be very much above this meanness: but he had most probably never read Morin's book; and this event may teach all those who give themselves up to the study of the sciences, that they never should neglect to read all that has the least relation to the object of their inquiry. It is only by reading a book that we can acquire the right to neglect it; and that of Morin surely did not deserve this contempt.

In finishing this memoir, let me be permitted to say a few words more respecting Morin, to whom it appears that justice has never been done in several respects. He had given himself up to reveries in judiciary astrology, which was certainly an obstacle to his reputation: but as an astronomer he was very far from being without merit. To appreciate him with justice, it is not with the astronomers of the present age that we must compare him. It is well known how much the sciences, and above all astronomy, have been improved during the last hundred and fifty years; but if we compare him with his contemporaries, we shall see that he was a man of some consideration, and corresponded with the most illustrious men of his time. He could not of course be acquainted with those sublime theories which only became known a long time after him; but he possessed all that then constituted the great merit of an astronomer. We find by the letters which Gassendi, Longomontanus, and many others, wrote to him, that they considered him as one of the best mathematicians of his age. He was professor of mathematics at the Royal College; he published, in 1633, A treatise of plane and spheric trigonometry, accompanied by tables of logarithms, sines, tangents, &c. He was the first who collected, completed, and demonstrated, what had been said before him on the science of the longitude, and laid the foundation of all that has since been done on that subject. He certainly has not carried it, nor could he carry it, to the degree of perfection which it has attained in our time, since many things were then wanting: and notwithstanding the very serious injury which many of the commissioners suffered on his account, they had reason to decide, that he had not completely resolved the problem of the longitude: but this did not hinder his book on the science of the longitude from being a very good one; and if in the present day it is only read by a few persons, it is probable that the reason is, because it is overcharged with irrelevant subjects, and above all with
 the

the altercations which he had with his commissioners, and with others; which now renders the reading of it very tedious. Nevertheless, had he only given this work, and the two inventions we have just mentioned, he would have deserved to be reckoned among those who by their works have contributed to the advancement of the sciences, and consequently to the cause of humanity. If it is not very interesting for the public to know who is the author of a discovery, of which they enjoy the benefit, it is of great importance that discoveries should be made; and the most certain means of increasing them, is to render full and entire justice to the authors. The reception given to their works is the most flattering part of their recompense; and it is to be wanting in gratitude to deprive them of it.

E.

XXXIV. *A Description of a new Anemometer.* By RICHARD KIRWAN, Esq., LL.D. P.R.I.A. F.R.S. &c. &c.*

THAT rain, on the presence or absence of which at the different seasons of the year, vegetation, and the success of agriculture, in great measure depend, and also the temperature of the atmosphere, to whose influence both animals and vegetables are subject, arises from, or at least is strictly connected with, the various directions and velocities of winds, is well known. Nor has it escaped observation, that the primary cause of the direction of the wind from a given quarter, as well as of the velocity of its progress, is the rarefaction of the atmosphere in that tract towards which it blows. The reason why air does not rush in from all sides towards the rarefied tracts, seems to me to be the inequality of its density in the surrounding tracts; for from that quarter, in which the mercury in the barometer stands highest, the air must preferably proceed. If the density be equal on all sides, as in some confined tracts, a hurricane happens: hence the advantage of ascertaining and comparing the degrees of its velocity; for, those being known, its cause and degrees of rarefaction may with great probability be inferred. Two causes of rarefaction are already known,—solar heat, and some internal chemical action, by which a quantity of air is converted into water, and sometimes even into a stony substance; this last being the most sudden and complete, the rarefaction of the neighbouring air arising

* From the Transactions of the Royal Irish Academy, for 1808.

from it is by far the most violent, but commonly of a much shorter duration and extent. An accurate measure of the velocity of wind has long been sought by meteorologists: several have been devised on the Continent, but only two, that I know of, in England. That which I now lay before the Academy seems to me to be the simplest and best adapted to the purpose.

1. The force of wind, to which the degrees of its velocity are proportional, is measured by that of gravity indicated in pounds and parts of a pound avoirdupois; the calculation is grounded on the observations of Mr. Smeaton, in the Philosophical Transactions, vol. li. p. 165.

2. Mr. Smeaton indeed observes, that the evidence of the velocity is not so great where this exceeds 50 miles, as when 50 or under; yet, from its agreement with other observations, I am inclined to think it fully sufficient.

3. A velocity of 123 feet per second was observed at Petersburg, an. 1741, 3 Much. 468, that is, at the rate of 83.8 miles per hour.

4. According to Lalande, in his Treatise on Navigation, 42 Roz. Jour. 221, the course of the trade winds is between 6 and 7 miles an hour.

5. Mr. Brice, Philosophical Transactions, 1756, p. 226, observed a storm whose velocity was 63 miles per hour.

6. A fair wind at sea, is that whose velocity amounts to 20 feet per second, or 13.63 miles per hour. Ibid.

7. Bouguer found the velocity of winter storms to be about 34 miles per hour, and in summer nearly 43. Ibid.

The distance from Holyhead to the Pigeon-house is 70 miles; then supposing the wind to be direct, and its velocity 30 miles per hour, and if we suppose the packer-boat to assume 0.4 of the velocity of the wind, it will arrive at the Pigeon-house in 5.8 hours.

Let W denote the velocity of wind in the open air, or meeting no opposition;

D = the distance of the place towards which the wind tends;

N the number of hours it requires to traverse that distance;

Then any two of these being known, the other may be found by the following formulas.

Given.	Sought.	N.	}	Thus if $W=30, D=70$
W. D.	N.	$N = \frac{D}{W}$		then $N = \frac{70}{30} = 2.33$
W. N.	D.	$D = W \cdot N$		$D = 30 \times 2.33 = 70$
D. N.	W.	$W = \frac{D}{N}$		$W = \frac{70}{2.33} = 30.$

A well-

- A well-sailing ship assumes $\frac{1}{3}$ of the velocity of the wind.
 The best-sailing ship 0.4 of the wind's velocity.

The above formulas applied to the calculation of a ship's way.

Given.	Sought.	
0.4 W. D.	N.	$N = \frac{D}{0.4 W}$
0.4 W. N.	D.	$D = 0.4 W N$
D. N.	0.4 W.	$0.4 W = \frac{D}{N}$

Thus the wind 30, and the distance 70 miles, then the number of hours requisite to traverse that distance will be 5.8 for $30 \times 0.4 = 12.0$ and $12)70 = 5.8$ hours.

Again 0.4 W. being 12, and the hours, 5.8, being given, the distance 70 miles, we have $5.8 \times 12 = 69.6$. by the second formula.

And lastly, the number of hours = 5.8, and space in miles = 70 being given, we have 0.4 of the velocity of the wind = $\frac{70}{5.8} = 12$; and dividing this by 0.4 we have the rate per hour of its course in the lower atmosphere.

Explanation of the Drawing. (Plate IX.)

Fig. 1. The anemometer, with a vane or weather-cock placed on the top, to show the direction of the lighter winds, which could not be known by the anemometer, on account of the weight of the necessary appendages annexed to it. This is raised of a sufficient height above the building, supported by a vertical axis or pole; the lower end of it passes through the roof and ceiling into an apartment below.

Fig. 2. The lower part of the pole or vertical axis AA. fig. 1. more enlarged, to give a better view of the necessary appendages. This pole is made of a slender spar, such as are made use of for strong setting poles for lighters, and handles for boat-hooks, as not being affected by lightning, which iron too often is, and the cause of the destruction of buildings and many lives. To this pole is fastened a frame of light wood by screws, in which the weights are confined, one on the top of another, in grooves, in such a manner as to work up and down with the greatest facility. The weights are connected together by cords, and marked 1, 2, 3, 4, &c.; the space between each, when drawn up by the force of the wind, is about one inch, as may be seen by the drawing, and each weighs one pound avoirdupois. To the top weight is fastened a line, and passing along the pole to the top, and over a brass pulley fixed at

at the bottom of the square tube, under the sliding rod *B*. fig. 3. as far as (*a*), and there fastened: in this sliding rod a groove or channel is cut underneath, to receive the line, so as not to impede its passage over the brass rollers *ff*. The line is composed of a number of common sewing threads, laid in different directions, well waxed, and inclosed in a cotton case, to prevent as much as possible its extension or contraction by the changes of the atmosphere.

Fig. 3. The wooden pipe or tube two inches square, fastened on the top of the pole *AA*. fig. 1. open on the side, to show the manner that the sliding rod *B* passes over the brass rollers *fff*, when the wind is sufficiently strong to lift up one pound by its force on the square surface presented to it, as (*b*) and (*c*), fig. 4.

Fig. 4. The wooden pipe or tube, in which are inclosed the sliding rod, rollers, and line, from the effects of the weather.

Fig. 5. The wooden frame, made of light wood, one foot square, covered over with very thin sheet brass, strongly painted, and varnished with copal. This frame is fastened to the sliding rod *B*. fig. 3. by means of a mortice, &c.

Fig 6. An enlarged view of the scale and index, which marks the greatest force of the wind during the absence of the observer, which is attached to the frame confining the weights, as *GH*. fig. 2.; and being connected with the hand fastened on the top weight (*d*. fig. 2.) raises the small weight (*e*); and this being counterpoised by another of equal weight, by means of a line passing over a small pulley, as represented by this fig. and also *G*. fig. 2, occasions the small weight, with its index, to stop at the number of pounds raised by the force of the wind, though they should fall down into their proper places on the wind's abating.

The bottom of the vertical axis or pole *F*. fig. 2, is sheathed with a steel point, and a socket, which rest on a wooden stand or frame, as at *D*. fig. 1, so as to turn with ease, and avoid as much as possible any friction.

I have also to remark, that in order to render this simple machine more complete, and answer the purpose of an anemoscope, as well as an anemometer, it is only necessary to apply to that part of the pole or axis, which is in the apartment, an index, and attach to the ceiling a thin deal board, or a sheet of pasteboard, with the points of the compass marked thereon.

A Table showing the Velocity of the Wind in Miles per Hour, indicated by Avoirdupois Pounds and Parts.

Miles per Hour.	Pounds and Parts.	Denominations.	Miles per Hour.	Pounds and Parts.	Denominations.	Miles per Hour.	Pounds and Parts.	Denominations.
10	0-492	Pleasant wind.	32	5-067	Storm.	53	13-923	
11	0-615		33	5-386		54	14-464	
12	0-738		34	5-705		55	15-007	
13	0-861		35	6-025		56	15-548	
14	0-984		36	6-391		57	16-089	
15	1-107		37	6-763		58	16-630	
16	1-279		38	7-132		59	17-171	
17	1-451		39	7-501		60	17-715	
18	1-623		40	7-873		61	18-403	
19	1-795		41	8-291		62	19-091	
20	1-968	42	8-709	63	19-779			
21	2-169	43	9-127	64	20-467			
22	2-370	44	9-545	65	21-158			
23	2-571	Very brisk gale.	45	9-963	Hurricane.	66	21-846	
24	2-772		46	10-430		67	22-534	
25	2-975		47	10-897		68	23-222	
26	3-265		48	11-364		69	23-910	
27	3-555		49	11-831		70	24-602	
28	3-845	High wind.	50	12-300				
29	4-135		51	12-841				
30	4-429		52	13-382				
31	4-748							

* * * The above table is followed by "A synoptical View of the State of the Weather at Dublin, in the Year 1805," marking the variations of the wind; the state of the barometer, thermometer, &c.—In this synoptical table the force of the wind is noted under columns headed in the following manner: (EDIT.)

Force of the Wind as indicated by the Anemometer.

Brisk gale, 1 to 2 lbs.	Very brisk, 2 to 3 lbs.	High wind, 3 to 4 lbs.	Very high, 4 to 5 lbs.	Storm, 5 to 6 lbs.	Great storm, 6 to 7 lbs.	Tempest, 7 to 8 lbs.	Violent tempest 8 to 9 lbs.

XXXV. *Analysis of the Mécanique Céleste of M. LA PLACE.*
By M. BIOT.

[Continued from p. 209.]

THE author also considers the general case in which the spheroid, supposed to be always fluid at its surface, may contain a solid nucleus of any given figure not differing much from the sphere. The radius drawn from the centre of gravity of the spheroid to the surface, and the law of gravity at this surface, have certain general properties, which the author has found out, and which are the more important as being independent of all hypothesis. The first consists in this, that in the state of equilibrium, the fluid part of the spheroid must always be arranged in such a way that the centre of gravity of the external surface may coincide with that of the spheroid. The permanent state of equilibrium in which the celestial bodies are, also brings to light some properties of their radii; for this state requires that these bodies should turn, if not exactly, at least very nearly so, round one of their three principal axes. Hence result certain conditions which their radii must satisfy, and these are explained by the author in a very simple manner.

He afterwards obtains, by the differentiation of the general equation of the equilibrium of spheroids, the law of gravity at their surfaces; and he deduces from it the length of the seconds pendulum, which is proportional to this gravity. Finally, the developed expression of the radius of the spheroid gives him the osculating radius, and consequently the degree of the meridian. These formulæ possess the valuable advantage of being absolutely independent of the interior constitution of the spheroid; *i. e.* of the figure and density of its layers. They depend solely on the expression of its radius, with which they are connected by very simple relations. On comparing these relations with each other, we find that the parts of the radius which enter under a finite form into the expression of gravity and length of the pendulum, undergo two successive differentiations, in order to pass into the expression of the degree of the meridian, and would consequently undergo three in the variation of two consecutive degrees; and as the differential of a quantity raised to any given power is always multiplied by the index of this power, it results, that terms scarcely sensible in themselves in the expression of the length of the pendulum might, if elevated to high powers, become considerable in the variation of the degrees; which explains in a very simple manner,

ner, how it is possible that the observed lengths of the seconds pendulum increase from the equator to the pole, nearly in proportion to the square of the sine of the latitude, whilst the variations of the observed degrees of the meridian differ perceptibly from this law. For the same reason, the aberration of the elliptic figure will be less sensible in the value of the horizontal parallax of the moon, which is proportioned to the terrestrial radius, than in the expression of the length of the pendulum which is given by the differentiation of the equation of equilibrium into which the radius of the spheroid enters under a finite form. The preceding formulæ may also serve to verify the hypotheses necessary for representing the measured degrees of the meridian. The author has made an application to that which Bouguer proposed, namely, to suppose the increments of the degrees from the equator to the pole proportional to the fourth power of the sine of the latitude; and he proves that this law is inadmissible.

The author applies these general results to the case in which the spheroid not being solicited by foreign impulses is formed of elliptic layers, all of them having their centres at the centre of gravity of the fluid. We have seen that this case is that of the earth supposed to be primitively fluid; and the author proves that it would still agree with it in the hypothesis of the figures of its layers being similar. He deduces from it, that then the radii diminish, and the degrees increase from the equator to the pole proportionally to the square of the sine of the latitude. He proves also by the help of the same formulæ, that on the most probable suppositions, suppositions which become necessary, if the spheroid has been originally fluid, its oblateness must be less than in the case of homogeneity. Finally, he establishes between the ellipticity of the earth, and the variation of the pendulum from the equator to the pole, this remarkable relation: *Putting unity for the length of the pendulum at the equator as much as the ellipticity of the earth surpasses that which would take place in the case of homogeneity, in the same proportion is the total increase of the pendulum from the equator to the pole exceeded by that which would take place in the same case; and reciprocally, so that the sum of this increase of the ellipticity forms a constant quantity.*

The author afterwards determines the attraction of spheroids the surfaces of which are fluid and in equilibrium, an hypothesis which takes place with respect to the earth, and which it seems natural to extend to the other bodies of the system

system of the world. He afterwards gives an extremely simple expression for the law of gravity at the surface of homogeneous spheroids in equilibrium, whatever may be the index of the power to which the attraction is proportional: for this purpose he makes use of the equation which takes place at the surface of spheroids differing very little from the sphere; and he deduces that in general, if the spheroid be a homogeneous fluid and endowed with a rotatory motion, the gravity varies from the equator to the pole proportionally to the square of the sine of the latitude; and what is singularly remarkable, this variation vanishes when the attraction is proportional to the cube of the distance; so that in this case the gravity at the surface of homogeneous spheroids is every where the same, whatever may be their rotatory motion.

In the preceding inquiries the author has supposed the effect of the centrifugal force and of the foreign attractions to be very small, with respect to the attraction of the spheroid, which has admitted of his neglecting the square and the other powers of these forces, as well as quantities of the same order: but he shows that it is easy to extend the same analysis to a case in which it may be necessary to preserve them. At last he arrives at this important conclusion,—that the equilibrium is rigorously possible, although it is only by successive approximations that we can assign the figure which satisfies it. Such is the result of M. La Place's labours on the attractions of spheroids. The uniform and direct manner in which this theory, so abstract and difficult, is derived by simple differentiations from a single fundamental equation, is doubtless one of the most remarkable things that analysis has ever effected.

In order to compare the preceding results with observations, it is necessary to know the curve of the terrestrial meridians, and that which we trace by a course of geodesic operations. If by the axis of rotation of the earth, and by the zenith of a place on its surface, we imagine a plane prolonged to the heavens, this plane will there trace the circumference of a great circle, which will be the meridian of the place; and all the points on the surface of the earth, which will have their zenith in this circumference, will be under the same celestial meridian. These points are therefore such that the normals, drawn through them to the surface of the earth, are all parallel to one and the same plane. According to this condition the author determines the curve which they form on the surface. This curve, which is the terrestrial meridian, is plane if the spheroid

spheroid be one of revolution, but in the general case it has a double curvature.

The geodesic line is a curve whose first side is a tangent in any given direction to the surface of the earth. Its second side is the prolongation of this tangent bent according to a vertical, and so on. According to this condition, the author determines the equation of this curve, which is the shortest that can be drawn between two points given on the surface of the earth.

The geodesic line is very proper for enabling us to become acquainted with the true figure of the earth. In fact, we may conceive at every point of the surface of the earth a tangent ellipsoid, and on which the geodesic measurements, the longitudes, and latitudes, reckoning from the points of contact, would be in a small extent the same as at this surface. If the earth were an ellipsoid, it would coincide with the tangent ellipsoid, which would be every where the same; but if this circumstance did not take place, the tangent ellipsoid would vary from one country to another; and these variations, which it is interesting to know, could only be determined by geodesic measurements made in different directions and in different countries.

The surface of the earth being supposed to differ a little from the sphere, the author gives the equation of the geodesic line; and considering in the first place the case in which the first side of this line is parallel to the corresponding plane of the celestial meridian, he deduces from it the length of the arc comprised between two given latitudes. If the terrestrial spheroid be one of revolution, this arc and the whole curve are in one and the same plane, which is that of the celestial meridian. It varies from it when the parallels are not circles; so that the observation of this variation may throw some light on this important point of the figure of the earth. The author by a very delicate analysis shows, that if the first side of the geodesic line be parallel to the corresponding plane of the celestial meridian, the difference of longitude of the two extremities of the measured arc is equal to the azimuthal angle of the extremity of the arc divided by the sine of the latitude. This very simple result is independent of the interior constitution of the earth, and of the knowledge of its figure. It is of very great importance in this theory; since, if the azimuthal angle observed is such that we cannot ascribe it to errors in the observations, we might conclude with certainty that the earth is not a spheroid of revolution. The author afterwards considers the case in which the first side of the geodesic

desic line is perpendicular to the corresponding plane of the terrestrial meridian, and he obtains an equation which determines the difference of latitude of the two extremities of the arc. It is very remarkable that the function which gives this difference is equal to the azimuthal angle observed at the extremity of the same arc, measured in the direction of the meridian and divided by the tangent of the latitude at the first point of this arc. This function may therefore be determined two ways; and we might judge if the values found, whether of the difference of the latitudes or of the azimuthal angle, are owing to the errors of observations or to the eccentricity of the terrestrial parallels. The author afterwards calculates the difference in longitude of the two extremities of the arc measured in the direction of the parallels, as well as the azimuthal angle formed by the extremity of this arc with the corresponding plane of the celestial meridian. Finally, he determines the osculating radii of the geodesic lines, whether drawn in the direction of the meridian or in the direction of the parallels, and he deduces from it that of the geodesic line, which forms with the meridian any given angle. Considering afterwards the osculating ellipsoid, the author teaches us how to determine it from the measurements of the earth.

We have previously seen that the elliptic figure must be that of the earth and the planets, supposing them to have been originally fluids, if in other respects, by becoming hard, they have preserved their primitive figure: it was therefore natural to compare with this figure the measured degrees of the meridian; but this comparison has given for the figure of the terrestrial meridians different ellipses, and which are too far removed from the observations to be admitted; whence it follows that the figure of the earth is more complex than had been at first supposed. Nevertheless, before abandoning the elliptic figure entirely, it is important to determine that in which the error is smaller than in any other of the same nature. The author gives two different methods for attaining this object; the first is generally applicable at all times, when we have a certain number of observations, which we suppose to be represented by a function whose form is given; it is requisite to determine this function in such a manner that the errors of observation may be less than in any other of the same form. Having, for instance, any given number of observations of a comet, we may by their means determine the parabolic orbit in which the greatest error is (abstracting from the sign of the error) less than in any other of the same nature:

but this method requiring very tedious calculations, when the number of observations is considerable, the author gives one more expeditious, and applicable to the observed lengths of the pendulum and of the degrees of the meridian. The ellipsis determined by this method, serves to ascertain whether the elliptic figure is within the limits of the errors of the observations: but even by this it is not that which the measured degrees indicate with most probability. This last in the author's opinion ought to possess the two following properties: 1st, That the sum of the errors committed in the measurements of the whole measured arcs should be nothing. 2d, That the sum of these errors, all of them being taken positive, should be a minimum. He gives a method for determining it according to the foregoing conditions; and this method, which employs the whole lengths of the measured arcs, has the advantage of giving, as it ought to do, so much more influence to each of these arcs, as it is more considerable in length.

The author applies these methods to the degrees measured at Peru, the Cape of Good Hope, Pennsylvania, Italy, France, Austria, and Lapland. The result is, that in the elliptic hypothesis we cannot avoid an error of 199 metres on some of these degrees; which is by far too considerable. The ellipticity corresponding to this minimum of error is equal to $\frac{1}{277}$, the polar axis being taken as unity. The most

probable ellipse gives this ellipticity = $\frac{1}{312}$, and it supposes an error of 336 metres in the degree measured in Pennsylvania; which appears inadmissible. This result confirms what was said before, that the earth differs sensibly from an elliptic figure. But there remains no longer any doubt respecting this, when the author, applying the same analysis to the operations lately made with so much care by Delambre and Mechain, deduces from them $\frac{1}{150}$ for the earth's ellipticity; an oblateness which, as the author observes, cannot subsist either with the phænomena of gravity, or with those of precession and nutation; for these phænomena do not permit us to suppose the earth to possess an oblateness greater than in the case of homogeneity, or above $\frac{1}{230}$, and the extreme accuracy and care used in the operations by the able astronomers just named do not admit of our ascribing the variation to the errors of the observations. To determine decidedly the magnitude of the quarter of

the terrestrial meridian from the arc comprised and observed between Dunkirk and Mont-Jouy, it is necessary to adopt an hypothesis for the figure of the earth; and by means of the irregularities which it presents, the most simple is that of an ellipsoid of revolution. Assuming this supposition, and comparing the arc measured in France with that measured at the equator, we deduce the quarter of the meridian, and the length of the metre, which is the ten millionth part of it. This comparison gives $\frac{1}{334}$ for the earth's ellipticity.

The author then shows, that, whatever may be the figure of the earth, the observed diminution of the degrees of the meridian from the pole to the equator requires a corresponding augmentation in the terrestrial radii, and consequently an oblateness in the direction of the poles. He then passes to the comparison of the elliptic hypothesis with the observed lengths of the seconds pendulum. Taking for this purpose fifteen selected observations, he shows that all may be reconciled to an elliptic figure, by only admitting an error equal to the eighteen hundred thousandth of the observed length. The ellipticity corresponding to this minimum of error is $\frac{1}{321}$, and that given by the most probable ellipsis is $\frac{1}{335}$. By this we perceive that the aberrations of the elliptic figure are less sensible in the variations of the length of the pendulum than in that of the degrees of the meridian. The theory of the attractions of spheroids gives, as the author has before observed, a very simple explanation of this circumstance.

The author applies the same methods to Jupiter, whose oblateness has been determined with accuracy. He first supposes this planet to be homogeneous, and compares the oblateness computed on this hypothesis with the observations. The result being found too great, the author concludes that Jupiter is less oblate than he would be if he were homogeneous, and that his density increases like the earth from the surface to the centre. In this case theory establishes limits between which must be comprised the ratio of the two axes; here these limits are very nearly approached, and the author shows that the observed axes of Jupiter are contained within them, so that gravity is yet on the point of agreeing perfectly with observations.

The author then employs himself with Saturn's ring: he supposes that an infinitely thin fluid layer spread into this surface would be in equilibrium in consequence of the forces

which animate it; and it is according to the condition of this equilibrium that he determines the figure of the rings. To obtain it, he conceives each ring as engendered by the revolution of a closed figure, such as the ellipse moved perpendicularly to its plane about the centre of Saturn placed on the prolongation of the axis of this figure. Introducing these circumstances in the equation of the second order of partial differences relative to the attraction of spheroids, and supposing the dimensions of the ring to be very small with regard to its distance from Saturn's centre, there arises an integral equation, which is the same as if the annular surface were a cylinder of an infinite length: and in fact we see that this case is very nearly that of the ring when the attracting point is near its surface. But, as this first approximation is not in general sufficient, the author gives the means of obtaining others more and more exact; and he shows, that to obtain them it suffices to know the attractions of the rings on points placed in the prolongation of the axis of their generating figure. Considering in particular the case where this figure is an ellipse, he gives the values of these attractions, as well on a point distant from the rings as on a point on their surface.

He then supposes the ring to be a fluid homogeneous mass, and the generating curve to be an ellipse. The general equation of equilibrium shows in this hypothesis the motion of rotation of the ring, and the ellipticity of the generating curve; he deduces from it again the limits of the ratio of the mean density of Saturn to that of the ring; and at last obtains this remarkable result, that the motion of the ring is the same as that of a satellite as far distant from the centre of Saturn as the centre of the generating figure is from it; which exactly conforms with the observations. He then shows that the preceding theory would still subsist if the generating ellipse varied its magnitude and position throughout the whole extent of the circumference of the ring, which might thus be supposed of an unequal size in its different parts, as appears to take place in nature. Lastly, he demonstrates that these inequalities are necessary to maintain the ring in equilibrium round Saturn: to prove it, he supposes the ring to be a circular line whose plane passes by the centre of Saturn, but without the two centres coinciding; and he shows that then the centre of Saturn will always repel the centre of the ring; so that, whatever may be the motion of this second centre round the first, the curve which it describes would be convex towards Saturn: it would finish therefore by receding

more and more until its circumference re-united itself to the surface of the planet. From this the author deduces, that in general, if the ring were similar in all its parts, its centre would be always repelled by Saturn's centre, if it ceased ever so little to coincide with it; so that the slightest cause affecting this coincidence, the attraction of a comet or of a satellite, would precipitate the ring down to Saturn, where it would be united for ever. It is therefore necessary, in order that the equilibrium might be firm, that the rings of Saturn be irregular solids of unequal width in the different points of their circumference, and such that their centre of figure should not coincide with their centre of gravity. The author then treats on the figure of the atmospheres of the celestial bodies.

A rare, transparent and compressible fluid, sustained by a body which it environs, and on which it hangs, is what we call its atmosphere. In proportion as the fluid rises from the body it becomes more rare in consequence of its spring: but if its exterior surface be elastic it extends without end, and terminates by being dissipated in space. The author concludes from these considerations, that there exists a state of rarity in which this fluid is without spring, and that it must be found in this state at the surface of the atmosphere. The figure of this surface must then be such, that the result of the centrifugal force and of the attractive force of the body must be perpendicular to it; which gives the equation of this figure. Considering particularly the case where the covered spheroid differs little from the sphere, the author deduces the equation for the layers of the same density of the atmosphere. Observing then that the limit of the atmosphere must be such that the centrifugal force of it be equal to the gravity, he demonstrates that the atmosphere has only one possible figure of equilibrium, in which the ratio of the least to the greatest axis, which is that of the equator, cannot be less than $\frac{2}{3}$. By applying these results to the solar atmosphere, we find that it can only extend to the orbit of a planet which would circulate in a period of time equal to that of the rotation of this body, that is to say, in twenty-five days and a half. It is therefore very far from reaching the orbits of Mercury and Venus. The zodiacal light extends far beyond these orbits, and appears in the form of a very oblate lens. The author concludes with certainty, that it is not the sun's atmosphere.

END OF THE THIRD BOOK.

[To be continued.]

XXXVI. *Cosmo-*

XXXVI. *Cosmogony of the Iroquois, or Five Indian Nations of Canada* *.

THE following sketch of the theological notions heretofore entertained by the aboriginal people whose descendants still inhabit the western parts of New York and the southern region of Upper Canada, was communicated to Dr. Mitchell at Fort Schuyler, in the year 1788, by the late reverend Sampson Occom, the famous Mohegan preacher and missionary, during the negotiation between the commissioners of New York and the sachems and warriors of the Six Nations, which terminated in the treaty with the Oneidas, Onondagas, Senecas, and Cayugas of that year. Mr. Clinton then administered the government of the state, and met the Indians, in person, accompanied by Messrs. Jones, L'Hommedieu, Benson, Varick, and Gangevoort, as agents on the part of the Commonwealth.

Their tradition concerning the origin of the world and of man, though wild and eccentric, has still the merit of being as credible as most others extant. An account of it was transmitted many years ago to Dr. Robertson, the celebrated historian of America, by a person eminently skilled in Indian researches. And it would probably have been noticed by him, had he finished the history of the British settlements in North America. But that writer having left only two chapters of this work, the one on the colonization of Virginia, and the other on that of New England, no mention is made of the character and peculiarities of these people, apart from the general survey he had taken of the aborigines in his former volumes.

Lieut.-governor Colden, the professed historian of the Iroquois, writes, "that, as to what religious notions the five nations of Canada have, it is difficult to judge of them; because the Indians that speak any English, and live near us, have learned many things of us; and it is not easy to distinguish the notions they had originally among themselves, from those they have learned of the Christians. It is certain they have no kind of public worship; and I am told they have no radical word to express 'God,' but use a compound word, signifying *the preserver, sustainer, or master of the universe*: neither could I learn what sentiments they have of a future existence." This extract is taken from his *Account of the Five Indian Nations which are dependent on*

* From Professor Mitchell's Lectures on Natural History, delivered May 17th, 1809.

the Province of New-York, &c. And this work was published at London as long ago as 1747. Notwithstanding the difficulties which beset every inquiry concerning the religious rites and tenets of rude nations, as stated by Dr. Robertson in his *History of America*, b. iv, § 7, the professor has thought it worth the while to preserve this remnant of antiquity, and to state it to his audience, rather than suffer it to perish on the lips of a declining and evanescent people. He offers it as a singular tradition, and worthy of being contained in the *Theogonia of Hesiod*.

“Originally,” the tradition runs, “the self-existing world consisted of mud and water, and was inhabited solely by aquatic animals and birds.

“At this time there was an universal language among the creatures, which they all used and could understand.

“They lived together in a most happy society, and performed for each other various and numberless offices of friendship.

“But while the beings of the nether world were enjoying themselves in these ways, a scene of great and general concern was exhibited in the world of spirits above.

“A distinguished young warrior in those upper regions laboured under an exhausting and dangerous disease, which rendered his restoration to health extremely doubtful.

“He was the favourite and the hope of the celestials, who, anxious for the recovery of their beloved hero, strove by every possible means to comfort and cure him. And they proffered their services in every way that in their judgment might relieve or delight him. They were unsparing of any gratification, to which the whimsies of his sickly brain seemed to be inclined,

“One day, as they were assembled and condoling by the loss they should sustain through the obstinate and increasing violence of the malady, a messenger arrived from the patient, who, in a hasty and panting voice, told them, that something was importunately required of them by their dying friend. The languid youth, he said, wished the nation to make an exertion of its whole strength. There was a tree of uncommon size and of great note in the village. It was his earnest desire that this tree should be pulled up by the roots. Instantly the work was undertaken. Scaffolds were built around. Cords were twisted, and tied to the trunk and branches. And after tugging a long time, the united effort of the whole world of spirits raised the tree from the earth, and held it suspended in the air.

“A vast and terrible cavity was left beneath. The bot-
tom

tom of this, by reason of its crookedness and depth, could not be traced by the eye.

“ On being told that the tree had been eradicated according to his request, the feeble youth begged that he might be conveyed to the side of the chasm and seated there. It was believed the odour of the fresh earth might tend to revive him. This being done, he turned his languid eyes toward the thronging people, and, espying a beautiful young female spirit standing near him, signified his desire that she might also be brought to the brink of the precipice and be seated beside him.

“ This having been immediately performed, and the girl placed by the warrior on the margin of the hole, he watched a favourable opportunity, and suddenly pushed her into it headlong. She rapidly descended, and in a few seconds disappeared from their view.

“ She continued rolling and tumbling down the perforation until she fell through into this lower world.

“ The young man then told them that he had been desperately sick of love; that he had been intolerably tormented by jealousy; and that the damsel whom he had precipitated into the pit, had been the object of his most ardent passion. He informed them she had slighted his fondest overtures, and given a preference to another. But having now plunged her to perdition in revenge for her neglect and scorn, he should soon recover his wonted health.

“ The attentive spirits at first felt much concern and shuddering at the accident. But finding their favourite's recovery was insured at a price so inconsiderable as the loss of the girl, their sadness was immediately converted to joy. And thus quiet was restored to the nation of spirits.

“ She continued to fall for several successive days, and at length drew near to the confines of this lower world. Her nearer approach was descried by a bald eagle, who was soaring very high upon the wing. Struck with the novelty of the appearance, he immediately gave the alarm to all the fowls of the air and inhabitants of the water. They quickly assembled, and held a consultation what was to be done.

“ It was unanimously concluded in the meeting, that the falling body, be it what it might, should not be suffered to plunge into the abyss and perish by drowning; but that some one of their number should immediately prepare himself to receive and sustain it on his back.

“ First the eagle offered his services to buoy up the ob-

ject; but the prevailing opinion was against him, under a persuasion that the air was not solid enough to allow him to attempt it with success. Then, the wood-ducks offered their aid; but it was objected that their backs were too narrow, and their strength too inconsiderable; it would be impossible for them to keep afloat, and they must infallibly die by submersion. The beaver next signified his willingness to perform the service; and a sentiment of approbation was on the point of being expressed, when a large tortoise made his appearance, and raised his knobbed head and spreading shell above the surface.

“ There was an instant decision that the tortoise was the fittest of all the creatures for the purpose, and was encouraged to fix and balance himself to receive the approaching phænomenon.

“ The outcast from the upper world by this time drew very near. For the tortoise had no sooner made himself as buoyant as he could, and brought his body to a poize, than she alighted upon his back.

“ Luckily she caught upon her feet. The tortoise bore the shock perfectly well. After the female visitant had recovered a little from reeling and staggering, she found herself in a short time almost overpowered by giddiness and faintness. In this condition, she sat herself down cross-legged upon the tortoise’s back, and, leaning forward with her head toward her knees, fell into a profound and refreshing sleep. It may be noted that, in commemoration of this event, the Indian women to this day accustom themselves to sit cross-legged.

“ On awaking, she was surprised to find, instead of the bare tortoise shell, a small circuit of earth, and spontaneously and miraculously outspread, and covered with bushes, vines, and fruits. She extended her hands, and gathered some of the blackberries, mandrakes, and grapes. After eating her fill and drinking some water, she lay down and slept again; for now there was room enough for her to stretch out her limbs at full length.

“ When she next awoke, she could see no water whatever. The land, by a continuation of the miracle, had already extended itself further than her sight could reach. Vegetables of every kind abounded on it; as also did four-footed animals. After a while she arose, walked about, and prepared for subsisting as comfortably as she could in her new and solitary abode.

“ But, before she passed many moons in her terrestrial
abode,

abode, pregnancy forced itself upon her notice. This was the consequence of an amour in which she had been engaged in the upper world. And it was on account of the preference she showed to the young spirit of her heart, that she became the object of that jealous temper in his rival, which thrust her from the high place of her birth.

“ In due time she was delivered of a female child, who grew thriftily, and until the age of puberty acted as the companion and assistant of her mother. During the infancy of this daughter, there was a great intimacy between her and some of the land animals. They were constant play-fellows; and, as she grew up to a more interesting size and figure, were engaging in their manners and more assiduous to please her. They frisked around her, played their prettiest tricks to entertain her, and in short employed in her presence all the arts of gallantry and courtship that they knew.

“ After some years were passed in this manner, the like accident befel the daughter which her frolicsome mother had experienced. She proved with child; and at the period of her gestation, twins, two male children, were born of her. It was always a matter of uncertainty with her, who was the father of the boys. It was certain, however, that the sire was either the *bear* or the *tortoise*. Accordingly, in tracing the genealogies of the tribes and families, it is an unsettled point at this time, whether that which derives its origin from the bear or the tortoise is the more honourable and dignified.

“ These children, so ushered into the world, were the **GOOD SPIRIT** and the **EVIL SPIRIT**. The difference of their tempers and dispositions manifested itself before they were born. While yet encircled in the womb, the former was content to lie still and be quiet, while the latter was unceasingly restless, and by kicking and scratching strove to give his mother all the torment he could. He finally declared to his brother, in one of their conversations, that he never would besoul and disgrace himself by coming forth through the natural passage; but that he would find some preferable and more decent outlet to day-light.

“ By the persuasion of his well-disposed brother, however, he was induced to moderate his restlessness until his mother's labour came on. It was the lot of the good spirit then to be born first. Whereupon his perverse and impatient brother took a resolution not to follow him along the dirty road through which he came, but to take an opposite course. With a violent exertion he therefore tore his way suddenly

suddenly through the womb, and, passing through the belly obliquely upwards, forced himself out at the armpit.

“The mother immediately expired under this complicated injury; but both the children survived, and were brought up by their grandmother. The old dame was at the same time so enraged at the conduct of her grandson the evil spirit, as respected his mother, that she determined to make all the amends in her power for the outrage done her sex. She accordingly divided the dead body of her daughter into two parts at the waist. With a strong whirl, she threw the lower limbs, together with the insulted organs, into the sun, where, hid in intolerable brightness, no person, however curious or audacious, can bear to look at them. The head, trunk, and upper limbs, she slung to the other luminary, where they are still visible in the form of *the woman in the moon*.

“The boys manifested, as they grew, very different dispositions. As they progressed in age and increased in stature, the younger was no less remarkable for his malignity and depravity, than the other for his virtue and excellence. But he was under some control from his grandmother, and was withheld from the commission of the worst kind of crimes during her life.

“After her death, being left to themselves, the brothers agreed to possess the earth together in an amicable manner, as their joint inheritance. Yet, even after this agreement, the propensity of the younger to mischief and vice was so irresistible that nothing could withhold him. Though several wrangles and scuffles had taken place between them, the good spirit became convinced that nothing but force could reduce his depraved brother to a sense of decency and order. Foreseeing that a necessity for another contest between them would shortly arrive, he resolved to exert all his courage and strength, and give his brother a sound and sufficient beating, once for all.

“An opportunity, as he had predicted, soon presented itself. Owing to some misunderstanding, a battle happened between them near the falls of Chamblee, not very far from the junction of the Sorell with the St. Laurence. The evil spirit was worsted in the combat; but, at length escaping from his brother's hands, sought safety in flight. To elude his antagonist's blows, he directed his course across the country towards the south, and, stepping with wide and hasty strides from mountain to mountain, reached the lower falls of Delaware before he was overtaken. Here his exasperated brother, who had all the while pursued close at
his

his heels, clenched him again. The conflict was renewed, and, after a hard and obstinate resistance, the evil spirit was overcome, and constrained to cry for mercy. Having bound himself by a solemn promise to behave better in future, he was dismissed, and permitted to go at large.

“ But he was no sooner at liberty than his wicked appetites returned. His engagements for good behaviour were broken. And he employed himself with an industry worthy of a better cause, in creating gnats, musquitoes, hornets, and rattle-snakes, and in producing briars, nettles, thorns, and poisonous plants, to the full extent of his ability, for the purpose of disfiguring the earth, and of annoying to the uttermost of his power the human creatures, whom he foresaw would be brought into existence, and be devoted to the good spirit’s will.

“ For, now, another important event took place, which gave origin to the human race. On a sudden, many of the animals who had lived on the land and in the water, underwent a strange transmutation. They laid aside their accustomed figure and disposition, and were transformed, the males to men, and the females to women. And according to the brutal species whence the human individuals are reported to have sprung, do the Indians denominate their families and tribes. And thus the descendants of the *bear*, the *deer*, the *tortoise*, the *wolf*, and of many others, distinguish themselves very carefully by the name of their first progenitor.

“ Thus was the world produced,” in the opinion of the Iroquois; “ thus the ruling powers introduced into it, and thus the race of man brought into existence.

“ As to the earth itself, it rests upon the back of the immense tortoise, who, in the beginning, received the female visitor from beyond the clouds. He supports it, balances it, and carries it with him wherever he swims on the vast expanse of waters. And the old persons relate that some of their warriors and hunters have travelled so far to the westward, that they have actually seen his enormous leg project from his body, beneath the shell, where the waves of the ocean roll against him in vain. They have also remarked, when he feels uneasy and changes his posture, the motion communicated to the land occasions earthquakes; and when he inclines a little to one side or the other, he subjects a portion of the earth to inundations and deluges.”

XXXVII. *On the Breeding of Fish, and the Natural History of their Generation.*

HAVING been favoured with a copy of some interesting practical communications on this subject, which were first published some years ago in the Hanover Magazine, and having hitherto met with nothing satisfactory in any English publication, we are persuaded that their appearance in our Miscellany will prove acceptable to many of our readers.

An Account of a Method of Breeding Fish to Advantage.*

To the Editor.

SIR, AS you have desired me to give you my opinion in what manner salmon, trout, and other fresh river fish, of which roes or spawns are to be obtained, can be bred to advantage, I was anxious to oblige you; and for that purpose I went to a place in the county of Lippe, to visit Mr. Jacobi, who has brought this kind of breeding of fish to great perfection; and who not only showed me his machines, but likewise told me his method, and produced a pregnant egg in the latest stage, in which the trout could be distinctly observed. The machine consisted of a large water trough, (which may be made either larger or smaller,) about twelve feet long, and fixed in a place where there was a water-fall from a spring, which was conveyed through a small gutter into the trough, so as to cause a great water-fall. Upon this trough was a cover like the lid of a box, with several holes in it of six inches square, which were filled up with a wire grating, not only to admit air, but so close as to prevent the water-mice passing through, which follow close to the fish at spawning-time, and are very fond of the spawn. At the lower end of this trough, about five inches above the bottom, was a hole filled up with the same kind of wire grating, and of the same size as that at the top; through which the water runs into a fish-pond or canal, by which means there is always in the trough five inches deep. In this trough was a kind of coarse gravel, such as is commonly met with in gravelly ponds, laid about two inches thick, enough to cover the whole bottom. December is the spawning-time for trout or salmon. You may at that time take a female fish, and press and rub its belly gently, and it will part very

* From the Hanover Magazine, No. 23, March 21, 1763.

easy with its spawn; without any prejudice to the fish, into a bason of clear water; then take a male fish and rub and press its belly gently in the same manner, to let the milt or soft roe out in the same bason where you have received before the female roe in; and then stir them together. It will be the same thing if we take a male and female fish and cut out the roe and milt and mix them up in the water, and it will do just as well as if both fishes were alive. Carry then this bason with the mixed spawn to the trough, before the water is let in; sprinkle it very thin upon the coarse gravel; then convey the water from the spring into the trough through the holes in the covering; and nothing is further to be observed at this time, than that the water may have its constant current through the wires, and that these wires may be kept clean from filth: the third or fourth day after, open the trough to inspect whether the spawn is not covered with slime or nastiness; in which case move with a flat hand the upper part of the water horizontally, and tolerably briskly; which motion will clean the spawn from slime, and at the same time turn the eggs.

In this manner does this ingenious gentleman breed annually vast quantities of trout; and he has observed, that as soon as the fish is out of its egg, it has on its belly a bladder, from which it receives its first nourishment, and which becomes every day less, till it vanishes at last; and so long as this bladder appears, he suffers the young ones to remain in the trough; afterwards he lets them out into the pond to seek for food for themselves. He has proceeded in the same manner with salmon, and with the same good success.

Extract from the Hanover Magazine, No. 4, January 12, 1765.

An Answer to a Question in No. 48 of the Hanover Magazine, 1764, concerning the Spawning of Fish.

To answer part of the question, I shall impart my observations, which I have made for a long time past, and such as I have lately made. I shall confine myself only to such fish as are found in ponds and rivulets in this country. After many years experience, I have found that the spawning of fishes differs every year; partly owing to the influence of the weather, or to the beds in which they spawn; some require hard and stony, others soft and slimy, others bushy bottoms, and some, herbs and grass. The trouts will not spawn but in a stony and gravelly bottom, although others frequently creep under roots of trees, and in hollows near
the

the shore, where they are sometimes so entangled that they may be caught with the hand; they avoid spawning there, but will return again to find a place where the water has a fall and runs briskly, and where there is a gravelly bottom. After they have chosen a place, they will beat violently into the gravel or coarse sand till they make a deep hole, and so deep that it is frequently to be seen the next day, notwithstanding the current stream. This shows what difficulty the trouts have to part with their spawn, as they, of all small fishes, have the largest eggs; they are longer about their spawning, and they frequently begin in November and continue till February. The fishermen are well acquainted with the spawning-places, and know how to make their advantage of it, by placing baskets near them, and they are sure of a good booty. I hear frequent complaints of people, that they have no success in breeding of trout; but they do not consider that they require a hard gravelly bottom and hard water; when both these are wanting they cannot spawn; and if they do, it turns to no account, and the old ones die soon. If they appear near the head of the entrance, and the surface of the water, it is a sure sign the water is too soft for them. Perches have much greater advantages in spawning, and seem to have no difficulty; they spawn against bushes, shrubs, or reeds, where it adheres; and when they cannot find any thing of this kind, they get near the shore where grass grows, sometimes under water, and drag their spawn along the grass; the male following the female immediately, and impregnating the eggs. When the weather is not very cold or stormy, the latter quicken in three days: those eggs that fall in mud or sand come to nothing; their time of spawning is in the beginning of the spring.

Of breams there are two sorts: one is called the *black* from their dark colour, and their spawning is when the black-thorn is in blossom: this kind spawns earliest; they require no stony or gravelly bottom, but any little plant serves them; as the eggs are inclosed in a glutinous fatty matter, they adhere easily to any thing. These fishes, and in general the most that belong to the species of the white fish (such as roach, dace, &c.), have further advantages in spawning. The male breams get against that time hard knots on the head and body, on which the female rubs herself so violently that she frequently loses many of her scales. The second sort of breams, which are called *white breams*, spawn later, and not till May. The gudgeons always choose sandy places for their residence and spawning. Pikes spawn at three different seasons in the

the

the year; the first part with their spawn in the two first months of the year, and are called *February pikes*; and if the water is even covered with ice, they approach the shore under the ice, till they find a little grass, on which they hang their spawn. The second sort spawns in March; their fry thrives generally best on account of the waters being then high, and the weather milder at this season. Therefore they will get into meadows overflown with water, and do not seem to care if their backs are even out of the water. They generally travel by pairs, and part with their spawn by continually rubbing against each other with great noise, and many times the larger devours the smaller in this business. When it happens that the weather is proper for them, and that the waters do not fall suddenly, but rather rise, and that the sunshine causes the air to be mild, they breed in great abundance; and these pikes, which are called *grass-pikes*, are afterwards to be met with in great plenty; which is looked upon in general as an omen that it will be a bad corn year; and it is commonly correct, not that it has any connection therewith, but that the soil in our climate (Germany) will not bear much wet for the growth of corn. The third part spawn in May, and are called *May pikes*.

Carps and carouches spawn but once a year, which is in the summer; they part with their spawn without much trouble, and in all places; but the spawn does not thrive every where; and we hear frequent complaints, that ponds which have had plenty have no young fry; but when ponds come to be inspected, it is found that those places which are proper for spawning are full of weeds or filth, for they require a clay bottom: a small spot in a pond is sufficient to breed vast numbers, and the spawning-ponds are full of weeds, and require to be annually cleaned, and the number of the young ones to be lessened: without this care the young fry grow poor, get thick heads, and on their scales a glutinous substance, which is called *grief*; and when they grow up are distinguished by the name of *stony carps*, or *stony carouches*. A good œconomist will never suffer any of these sorts to remain in his ponds longer than three years; and in a middling pond seldom above twelve female and three or four male carps or carouches. When the store carps are put into the spawning ponds, some tenches are put in along with them; and when the sperm of the male tench is mixed with the female spawn of the carp, it produces what we call *spiegel carps*. It is believed that a fish is produced from the mixture of carps and

and carouches, and these are called *hemelings*; but this sort is not fit for breed, and when caught are generally amongst the class of white fish.

It is remarkable that eels resort up streams and rivers in vast numbers in the hottest time of the year, viz. in June and July, and that they then discharge small worms, which it is believed turn into eels. For as soon as the water grows cooler they swim down with the stream, and are caught in abundance near water-mills, notwithstanding there remain always enough in the higher parts of the river and rivulets, and I have found various species among them. We have likewise a small kind of tortoise here in our rivers: these lay small white oblong eggs, smaller than pigeons' eggs; they lay them always in sand, where they can have the strongest noon-sun, which hatches them.

J.A.D.D.—*Celle*.

[To be continued.]

XXXVIII. *On the Generation and other obscure Facts in the Natural History of the Common Eel.*

To Mr. Tilloch.

SIR, **I**N your 133d Number for May last, page 410, it is stated as a curious fact in the natural history of the common eel, that a number, consisting of old and young, had been discovered in a subterranean pool at the bottom of an old quarry, which had been filled up and its surface ploughed and cropped more than twelve years. The information was evidently intended to convey an opinion that the young eels, found in the pool, had actually been bred therein; and could that circumstance have been unequivocally established, it would have been a new and interesting fact in the natural history of the animal. I however imagine, that a strict investigation of all the circumstances of the case, made on the spot, would have shown that the young eels had recently found their way into the pool, in the same manner as the old ones had formerly done; that is, by some aqueous communication, however temporary or trivial, with any the most insignificant adjoining brook or rill. It is certainly difficult to conceive how even a subterranean pool can preserve its water for more than a dozen years, perfectly isolated from all other water; and if any communication, however temporary, and however minute, had existed, the circumstance of finding the old and young eels together would be only an ordinary occurrence. Indeed I find

find no difficulty in pronouncing, that the case spoken of furnishes no satisfactory evidence of the fact it was intended to establish.

I believe there is no animal, if we except man himself, that is so universally disseminated over every climate and country in the globe as the common eel. In almost every instance where fresh water either flows, or is permanently stationary, the eel is an inhabitant; and throughout every part of our own country, not only every river and brook, but also every piece of stationary water, from the largest lakes down to many of our common wells, are found, in the proper season, to abound with eels; and yet both the place and the manner of their propagation still remain a question in zoology. There are also many other facts in their history that are very obscure, and it would be an interesting addition to the researches of the British zoologist to have the whole satisfactorily cleared up. In furtherance of this object, and to narrow the field of inquiry, I here offer, Mr. Editor, such facts as have fallen within my own observation, of the natural habitudes of the eel. They are chiefly intended to induce some of your intelligent readers, whose situation furnishes them with better sources of information, to communicate what they can learn on the subject.

In all inland waters eels abound without number in summer, but disappear in winter. This disappearance has been variously accounted for, and it has been very generally imagined that a large proportion hibernate by bedding themselves in mud; a notion which, I believe, is quite as visionary as the hibernation of swallows under water. Were eels ever in the habit of penetrating into mud, they would naturally enough shelter themselves therein when exposed to imminent danger, and no other mode of escape presented itself; but I have seen very many instances of muddy pools, purposely and speedily drained off, where multitudes of eels crawled over the light surface of the mud in all directions to escape, and without ever attempting to conceal themselves by penetrating into it. The full and clear eye of the eel also furnishes evidence that Nature never intended the animal to be buried under mud.

The disappearance of eels in rivers and brooks may be well accounted for by their emigration to the sea. This emigration is called their *running*. It commences in autumn, when immense quantities pass down the streams. Great numbers take the advantage of descending with floods, but a large proportion pass downwards in the night,

and only in the darkest and most tempestuous nights. Moonshine wholly suspends their progress; and even a temporary gleam of light, when the night is otherwise favourable, immediately interrupts their journey. This proves that their emigration is not a casual but a premeditated system in their existence: and it also displays their instinctive cunning; for, being an easy prey, when discovered, to otters, herons, and other nocturnal enemies, it is only in the darkest nights that they can travel in safety. During the period of their run, vast quantities are caught in bag-nets set across the streams. There is reason to suspect that all the eels in rivers do not run for the sea, as very early in the spring large eels abound in rivers at such a distance in-land, as renders it highly improbable that they can have ascended so far at so early a period; and indeed it is yet an unascertained fact, whether, of the vast multitude which unquestionably do pass downwards to the sea, any of them do again return and ascend to any distance up the streams. If, indeed, this retrograde emigration really existed to any extent, there are thousands of situations on our streams where it must have been every season perceived; and yet it has not only not been discovered, but the instances are frequent, where the obstacles on many of our streams render it impracticable, and where, nevertheless, large eels are found above these obstacles as early and as abundantly as below them. The probability therefore is, that few or none of the vast numbers which descend the streams ever again return; and then, as they are never discovered in the sea itself, the question of what ultimately becomes of them, is just as obscure as that of their generation.

There are many lakes, and multitudes of pools, abounding with eels, and from which they cannot run on account of the insufficiency of the outlets; and in these situations the eels most certainly continue during the period of their existence. There, however, they regularly disappear in winter, and the manner of their hibernating is entirely unknown; but as no species of animal with which we are acquainted ever does breed during the time of its hibernation, (the thing indeed seeming physically impossible,) and as eels in these confined situations are taken at all other times, without any vestige of propagation being discovered amongst them, the inference seems conclusive, that eels never do, under any circumstance, breed in fresh water. Were it indeed practicable in a single instance, it would be equally so in thousands of others where the circumstances are so similar; and it would be passing strange
if

if a solitary quarry-pit, which had been excluded for a dozen years even from day-light, were to discover to us an occurrence which is never displayed in our multitudinous open pools, where the same animals are equally restricted from escape.

In contradistinction to the vast emigration of old eels down the streams in autumn, an immensely greater migration of young ones commences up the streams in spring and summer. Their size varies between the smallest and the largest darning needle. They are called *elvers*, and abound in some of our large rivers to an inconceivable extent. In some places bushels of them are taken with baskets fixed on to the ends of poles, and drawn swiftly through the water. Their progress is always along the banks, and numerous portions pass up into all the lateral streams. The smallest brook and the minutest rill that can run receive their proportion; and it is solely in this way that every piece of water, however or wherever it may be situated, receives the eels that are found in it. The smallest possible trickling of water from any pool to the nearest brook, is sufficient to enable these little indefatigable animals to wind their way up to the source. The instinct, indeed, which impels them upwards against all moving water seems incessant and irresistible; it surmounts every difficulty, and perseveres successfully against every obstacle however imperious. During the low state of streams in the early part of summer, they may be found at weirs, mill-dams, cascades, and other elevations across the streams, ascending by the margin of the water perpendicular walls many feet in height, where the least crevice in the stone, or patch of moss, affords them a hold; and they will even find their way over vertical dry boards, by adroitly employing their glutinous exterior. I have taken them in handfuls from patches of wet-moss against erect walls, completely out of the water, and where the height and distance to be surmounted would require the persevering efforts of many days. In very small pellucid brooks, adjacent to rivers where they abound, they may be seen wriggling up the little streams in endless succession for weeks together. Great numbers doubtless perish by ascending the temporary rills produced from rain, and by reaching spring-heads, and situations where the water is insufficient for their growth and support; but in this, as in every other instance, provident nature has guarded against all such casual expenditure by the superabundance of the production.

In the larger rivers communicating with the sea, although the evers appear to advance in vast bodies, I do not imagine their migration, either in its commencement or progress, is made in concerted shoals; it seeming more probable that the number found together is accidental, and arises from the continual supply sent off from the quarter where they originate. This is confirmed in the small streams, where each individual is seen making its way by its own solitary efforts.

In summer all the large eels in rivers and brooks conceal themselves during the day under large stones and roots of trees, and in the crevices of rocks and walls, and even in earth-holes of the banks; and in these situations they obtain a large proportion of their food, being always on the watch to seize small fish, or other prey that the stream or accident throws into their concealment; and I think it is much more probable that the eels which do not find their way down to the sea, pass the winter in similar situations, rather than bedded in mud, or in any other of the fanciful modes which have been assigned them.

Such are a few of the principal facts in the natural history of the common eel, a creature which every where surrounds us in the greatest abundance, and yet its origin and final disposal are equally unknown. That it never does breed in fresh water seems to be a fact well established; and the periodical descent of the old ones to the sea, and ascent of the young ones from thence, strongly evince that the scene of their propagation is in the sea itself, or very near to the mouths of rivers, and that it is there that inquiries on the subject should be prosecuted.

The growth of the eel, like that of most other fish of prey, does not appear limited to any determinate natural bulk, but to be governed only by the age and abundance of food. In this country they are indiscriminately of every size, up to eight or nine pounds weight. They have generally been supposed viviparous: but the immense abundance of the young certainly bespeaks an oviparous progeny; and this is supported by analogy in the lamprey eel, which breeds commonly enough in most of our estuaries.

The tenacious vitality of the eel is well known, and is very extraordinary; for after decapitation, skinning, and embowelling, the separated portions of the body will still exhibit strong movement. This is a property seemingly common to all similarly lengthened animals, and obviously results from the comparatively small proportion of nerves
which

which originate from the brain, and the much greater which branch off in succession from the spine into the adjacent parts; an arrangement which distributes the source of vitality along the whole frame of the animal.

I am, sir, your most obedient humble servant,

JOHN CARR.

Princess Street, Manchester,
October 7, 1809.

XXXIX. *Experiments on the Production of Sounds in Vapours.* By M. BIOT.—*Read at the Institute, October 12, 1807*.*

NUMBERLESS experiments have been made by natural philosophers on the production and propagation of sound in different mediums: they have demonstrated that it neither is produced nor propagated in vacuum; they have examined its transmission through liquid and solid bodies: but no one, to my knowledge, has repeated those experiments in vapours, and yet this research is well adapted to excite curiosity; for in discriminating between the facts which experience has disclosed relative to the constitution of vapours which fill a space, and in applying to them mathematical principles, the foundations of the established laws of the minute vibrations of elastic fluids, it is evident, that absolutely no sound should be produced in them.

In fact, it is proved by the experiments of Deluc, Saussure, and Dalton, that the quantity of the vapours of water, or of any other liquid formed in vacuum, depends alone on the dimensions of the space and on the temperature: in short, if this vapour has an elastic force, capable of sustaining the manometer at a certain height, and if it be slowly compressed, so that it may occupy less space, the elastic force will not increase by this compression, as would happen to a permanent gas; but part of the vapour will assume the liquid state, without which the manometer varies, and it becomes stationary only as it agrees with the new limits to which the space is reduced. But the contrary will happen if the space is increased instead of being diminished: a fresh quantity of vapour will arise to fill it, without producing any change either in the elastic force or in the manometer. These results are perfectly established by philosophers, whom I shall hereafter quote, and we may with great ease be convinced of their accuracy. For the

* From *Mémoires de la Société d'Arcueil.*

purpose it is sufficient to introduce into a barometer a small quantity of any liquid, and to measure the height at which the mercury stops after being depressed by the elastic force of the vapour that is formed. If then the external surface of the mercury is either elevated or depressed, the interior column will rise or fall in the tube precisely in the same proportion; and according as the space which remains in the top of the tube is diminished or increased, a part of the vapour will precipitate itself or rise afresh; but the temperature remaining the same, no variation will appear in the elastic force.

Now, supposing a sonorous body vibrates in a similar medium, each of its oscillations will diminish, in one sense, the space, and will augment it in the other. Thus on one side there will be a small quantity of vapour which will pass into the liquid state; and on the contrary, a small quantity of liquid that will assume the state of vapour. These condensations and expansions will take place very near the sonorous body, in the immediate vicinity of the vibrations; but they will not be further extended. Thus the impulse will not be exerted on the remaining fluid mass, and consequently the sound will not be transmitted. Now let us suppose that the sonorous body, compressing the vapour by its rapid vibrations, mechanically disengages from it a certain quantity of heat. This supposition is not at all improbable, for it is well known that much heat is emitted during the condensation of vapour. For instance, the vapour of water, according to the experiments of Watt, sets at liberty, whilst passing from the æriform to the fluid state, heat sufficient to raise the mass of water thus formed to 525 of the thermometer centesimal. Paying attention to this circumstance, the effects of a sonorous body on vapour are not the same; the compressed portions maintain the state of an elastic fluid in spite of the diminution of space, on account of the liberated heat, which gives them a momentary increase of power. On the contrary, in the expanded portion, the decrease of temperature prevents a new formation of vapour, and occasions a diminution of elasticity. The phænomena which are produced near the sonorous body, are, then, of the same nature as if the vapour became a permanent gas. They consist of increments and diminution of elasticity successively and momentarily produced, spreading their effects from strata to strata through the whole fluid mass, so as to permit the production and propagation of sound.

Experiments, therefore, on the production of sound in
vapour

vapour are very proper to decide the question, whether heat is really disengaged by the effect of the vibrations of sonorous bodies in an aëriform medium, as we see generally takes place on all rapid compressions. To this test, and it is a decisive test, may the ingenious idea of M. La Place be submitted, by which he has found means to reconcile the mathematical theory of the propagation of sound in air with experimental results, in which the disengaged heat was duly attended to; for, if the effect which he infers does not really take place, the vibrations of sonorous bodies in vapours ought absolutely to produce no sound; and if any is produced, it can be considered only as the sole effect of the liberated heat.

Influenced by this motive, I made on the subject some experiments which were attended with evident success; and I have since repeated them in a more complete manner at Arcueil with my friend Aiméée Berthollet. M. Berthollet and M. La Place were present at those experiments, and fully satisfied themselves of the truth of the facts which I proceed to relate.

We used a glass balloon of the capacity of 36 litres; its orifice was closed by a perfectly tight stop-cock, so that an exhaustion might be made, and preserved good. To this another might be connected, that, by pouring a liquid into the intermediate hollow and closing both cocks, this portion of liquid might be introduced into the interior of the balloon without any danger of admitting the least external air. Lastly, the sonorous body was a small bell suspended within by a very fine cord tied to the lower stop-cock.

First, a vacuum was formed in the interior of the apparatus with the greatest care, and even the largest part of the hygrometric water of the balloon, which was always very dry, was abstracted. Then holding the balloon by the stop-cock, the bell was set in motion, satisfying ourselves that the blows fell with force on the metal; and whatever attention was paid, or however near we were to the balloon itself, it was absolutely impossible to distinguish any perceptible sound: therefore sound is not sensible in the vacuum; a fact constantly in harmony with the experiments of Hawksbee, and of all other natural philosophers.

Then proceeding as I have described, a small quantity of water was introduced, part of which rose in vapour. Immediately the sound became perceptible; yet the density of this vapour was very little, the temperature being no more than 19 of the thermometer centesimal: to increase it an excess of water was added, and the balloon was carried into

a green-house (*une étuve*), the temperature of which was 46° : then the sound became very sensible; it was heard by us, without inclining ourselves to the balloon, and even through the door without the green-house:—there yet remained in the balloon water in the liquid state: thus there is no doubt of the production and propagation of sound in watery vapour.

When the balloon was taken out of the green-house its temperature quickly fell: of course the principal part of the vapour raised by the means of temperature was precipitated; the sound likewise appeared very sensibly diminished. Without making any change in the apparatus, the same quantity of alcohol as water was introduced. Water considered as 1st, the specific gravity of this alcohol was 0.823. The vapour formed of this mixture was necessarily of greater density and elasticity than that of water at the same temperature; the sound too was much more sensible, it was heard from the extremities of the rooms forming the Museum of Natural History. Thus is sound also produced and propagated in the vapour of alcohol.

For our conclusive experiment we made trial of the vapour of ether: it was peculiarly interesting to us on account of its great density and elastic force, which are known to be very considerable; two circumstances which should increase the intensity of the sound. The balloon was first dried, as humidity diminishes the tension of the ether; then the atmospheric air was freely allowed to enter until an equilibrium was produced with the external pressure, which was 0.7613; the balloon was taken into a long alley in the garden, and the sound of the bell was found to be sensible even to the distance of 145^m; beyond this it became so weak that the sensation was not sufficiently distinct. The temperature was 17.75. Having measured by this experiment the intensity of sound produced in atmospheric air, a vacuum was again made in the balloon, and more sulphuric ether was introduced than the temperature could raise in vapour. The specific gravity of this ether was 0.759; the elastic force of its vapour, measured by being introduced under a barometer purged of air, was 0^m 35.49 at the temperature of 17.56. The balloon being thus filled with vapour was removed to the place where the preceding experiment had been made, and the sound was ascertained to be sensible at the distance of 131^m.5, a convincing proof that sound is produced and propagated in vapour as well as in permanent gas. But we have proved that this can only be effected by the instantaneous variations of temperature de-

terminated by the vibrations. Hence it is evident that this cause is the true one; and according to the beautiful remark of M. La Place, there is an absolute necessity to pay attention to it in the mathematical theory of the propagation of sound, although it cannot be verified by means of the thermometer, as it is an instrument not to be affected by successive and momentary variations of heat, similar to the barometer, which does not show the instantaneous changes of the elastic force, the cause of sound, and yet the reality of those changes is acknowledged by the whole world.

XL. Observations on the remarkable Efficacy of Carrots, under a new Mode of Application, in the Cure of Ulcers and Sores. By Mr. RICHARD WALKER.*

THE carrot poultice is an application which has been long in use to correct the disposition and improve the discharge of the putrid or scorbutic ulcer.

The manner in which it is usually applied, is by grating, or scraping the carrots fine, and laying them on raw.

I have lately had reason to believe, that the effects of it may be considerably increased, by varying the mode of application.

Several cases occurred in the Radcliffe infirmary, during the summer and beginning of the winter last year, of the true, malignant, scorbutic ulcer.

All the common methods of treatment were adopted, and of course the carrot poultice was not omitted.

The inefficacy of it however was too evident.

In consequence therefore of the ill success attending this practice, several of the cases terminating fatally, and as fresh instances were continually occurring, the following change was at length tried, in the use of this remedy.

The carrots being previously cleaned by scraping and washing, were split and boiled till quite tender, in a small quantity of water; the liquor was then strained, or poured off, and the carrots beaten in a mortar, to the consistence of an uniform soft moist pulp.

The ulcers were first washed clean with the liquor rather warm, in which the carrots had been boiled, sometimes fomented with it, and the carrot poultice being previously spread ready, that the sore might be as little exposed to the air as possible, applied cold.

This was repeated night and morning, and oftener when

* Communicated by the Author.

the quantity of discharge, or other circumstances, made it necessary; but this was seldom required, when the mode above mentioned was adopted sufficiently early; that is, before the sore had made much progress in its scorbutic state.

It scarce need be observed, that this disposition was known to have taken place, when the ulcer, from being firm, florid, and discharging good pus, became spongy, pallid, and discharged a considerable quantity of a thin, bloody, or gleety kind of matter,

The superior effects of this treatment were apparent in a very short time; in a few days the sores (several of which, before, were spreading rapidly, threatening the lives of the patients) were obviously improved; and in short, without any interruption to their progress in amendment, they were all of them gradually restored to a healthy appearance; and the cure finished, either by a continuance of this, or the methods ordinarily used to sores in a healthful healing state.

In all the cases above alluded to, bark, opium, &c., were as usual administered.

Nothing, however, has been particularly stated with respect to the exhibition of such remedies; as the object of the present paper is merely to direct the attention of practitioners to the use of the carrot poultice, and to recommend, under the sanction of many successful cases, the mode of applying it above described*.

Oxford, November 2, 1795.

November 30, 1803.

Since the above was written, a very considerable number of similar cases have at different times occurred, in which the efficacy of the carrot poultice, applied as above, has been abundantly confirmed; viz. very large sores chiefly on the leg, extending in some instances from the knee to the ankle, originating from accidental injury, habitual ulcers likewise, surfaces of stumps, and other sores after operations, all having assumed the morbid disposition before men-

* The antiseptic power of the carrot poultice has been ascribed, I believe, to the carbonic acid gas which the sore is supposed to imbibe from it during its application; hence it might be inferred that the carrot was fittest for use in its raw state.

I am however rather inclined to impute the efficacy of the carrot to its mild, anti-putrescent quality, depending chiefly on the pulpy saccharine matter it contains, in common with other vegetables, but in greater abundance; meliorated and softened into the fittest consistence by boiling and pounding for application to the tender, irritable surface of ulcers, sores, inflamed skin, &c.

tioned.

tioned. In every one of these cases the carrot poultice has been the immediate and constant resource, and with the completest success*.

As the efficacy of carrot poultice in different sores, and the fittest mode of its application, have, occasionally, ever since its adoption, engaged my particular attention, viz. for a period of nearly ten years, I am now enabled to speak more confidently, and with greater precision on the subject, and shall therefore give a more particular detail of every circumstance relative to it; premising in addition to what I have before said respecting that morbid disposition of a sore which requires this remedy, that it is commonly preceded by a more than usual disposition in the sore to bleed on the slightest touch or motion, and very quickly after this appearance the diseased state alluded to follows.

The carrots are now cut in thin transverse slices (instead of being split) for boiling, and the poultice when ready, observing to have it as moist as it will admit of without the inconvenience of its running about, instead of being spread on the cloth, is applied wherever the situation of the part will allow, by laying it on in portions with the hand, filling up first the cavities lightly, and then laying a coating of it about the thicknes or rather more than that of an ordinary poultice, over the whole surface of the sore, and considerably beyond the edges of the sore; pressing it close, smooth, and of an uniform thickness, quite to the edge of the poultice; otherwise it will become dry at the edge, and occasion some inconvenience in removing, by its adhesion.

The cloth or fine linnen is then to be applied and pinned tight over it; and a short roller may be used in order to keep the poultice uniformly close, and prevent it from being displaced †.

The more recently the carrot poultice has been boiled and prepared the fitter it is for use, therefore it is best when prepared immediately before using. But as the process of boiling the carrots sufficiently requires some time, enough may be made at once for two or three days consumption, but not longer, particularly in hot weather, when indeed it should be prepared daily; and when it is necessary to

* Large wounds and ulcers not unfrequently acquire an ill-conditioned state, notwithstanding the most skilful application of adhesive plaster, requiring a suspension of that mode of practice for a time.

† The method here described of applying the poultice was found convenient in very large sores with irregular surface; but in general it may be applied in the usual way spread on cloth, observing that the fresh poultice be ready to be applied immediately on the removal of the old one.

warm it for application, this is best effected by placing a bason containing it in a vessel of water over the fire.

It is particularly requisite that the carrot poultice be applied as moist as can be, in order that it may not become too dry by the next time of application.

As many of the cases in which it is applied are those in which the temperature of the body and the sore are considerably above, or hotter than the healthy temperature, particular care should be taken that in such cases the poultice be applied so as to produce in the patient a sensation of coolness; but in ordinary cases, a sensation of warmth.

Most cases require it to be applied twice in the day, viz. every morning and evening; and very few indeed require it oftener.

If the sore should require from its foulness to be washed at the time of dressing, it is best done by squeezing a sponge full of the liquor out of a bason containing it over the sore repeatedly (catching the foul liquor in a bowl) till cleansed; the outside should then be wiped dry to the edge; the sore itself, however, should on no account be touched with the sponge, but be cleansed with lint if necessary*.

The liquor may be that in which the carrots have been boiled, or in defect of that, milk and water or pure water, observing that its temperature be not hotter than the sore can bear with the most perfect ease to the patient. The washing may be omitted unless when the sore is very foul †.

The effect of the carrot poultice thus applied is to correct the fœtor or stench of ill-conditioned sores, and to reduce them to a perfectly healthy or good-conditioned state; moreover to thicken and diminish the discharge as well as correct it; hence it follows that it is particularly indicated in large sores with too thin or too copious a discharge.

When the sore is found to be sufficiently restored by the use of the carrot poultice, it should be dressed by applying first a single stratum of loosely made lint, not of the close compact kind which is made by an instrument; then a pledget of any common simple cerate, spread fresh and rather thick on fine cloth if the sore be very large, otherwise upon fine lint, sufficient to cover the edges of the sore

* This precaution is particularly necessary in putrid cases, to avoid the danger of keeping up or renewing the contagion in the sore.

† It is essential that the sore be as little exposed to the air as possible; hence it is better not to be very solicitous in cleansing the sore, the repetition of the poultice effecting this sufficiently.

completely,

completely, and over this a defensative plaster in the usual way of epulotic cerate on tow, with a compress and moderately tight roller. Dressing once a day is commonly sufficient, that is, every morning; but if the sore is large, or whilst the discharge is copious, it is better to dress it twice every day.

If the discharge is considerable, the stratum of dry lint upon the sore may be thicker, that is, in all instances just sufficient to absorb or retain the discharge.

It is not amiss, when the sore is become apparently fit for dressing, to apply one or two poultices more, having a single stratum of fine lint applied as above, immediately under the poultice, and then proceed as before mentioned.

The carrot poultice may be safely and efficaciously applied to sores in a healthful, healing state; but as sores then require pressure by bandage, and other management, known to every experienced surgeon, it is best to stop the use of it at this stage.

Since the effect of this carrot poultice is in a peculiar degree to diminish as well as thicken the discharge of a sore, it should never be used where an increased discharge is required, from mischief being likely to arise by pent-up matter; as when any part becomes swollen or inflamed for want of a free discharge at the sore, in that case a soft emollient poultice and the practice usual in such cases must be adopted*.

The carrot poultice in this form is applicable to all other species of sore, viz. venereal, cancerous, scrophulous, &c., and will be found, with the aid of proper medicines, the best application for the purpose of keeping the sores in good condition, and healing such of them as are not in their nature incurable.

The carrot poultice as above is a good application to excoriations of the skin in any part, or from any cause or disease where a thin disagreeable discharge occurs.

* Cases of this kind in which alone its application is objectionable, cannot be confounded with the dry, foul, or scorbutic ulcer, in which the carrot poultice by correcting the disease promotes a healthy discharge, and separation of sloughs; nor with sloughs arising from various other causes, such as sometimes occur in the course of the cure of gun-shot wounds, burns, &c., in which it is equally efficacious. Unctuous applications to sores of large surface are apt to produce superficial sloughs, which increase, or spread, by continuing the use of such applications—this disposition not unfrequently occurs in extensive scalds. Where such sloughs, accompanied with intensely inflamed edges, are forming from this cause, it is truly astonishing to observe the effect of this specific application in arresting the progress of this disease, by the almost immediate vanishing of the inflammation, the quick separation of the sloughs, and the rapid progress of the sore to a healthy healing state.

In the cases before mentioned where the carrot poultice is improper from pent-up matter, if the surface of the sore has acquired the scorbutic taint, a thin stratum of the carrot poultice may be applied over that surface, and the emollient poultice * over it, until that disposition is corrected.

The carrot poultice, as may be naturally inferred from what has been said of it, may be applied with singular good effect to a variety of other diseases which produce a thin, hot, acid humour on the part, viz. ophthalmia, herpes, &c.

In old habitual ulcers the carrot poultice may be applied at any time when the sore is foul or ill-conditioned; and particularly when such a sore has a dry sordes on the surface, carrot poultice applied thin over that surface and an emollient poultice over it of bread and milk, never fail to bring on quickly a discharge of good-conditioned pus.

It sometimes happens when a cure is tedious, as in sores of extensive surface, or of a languid or sluggish disposition; that from the mere changing of the application for another a short time, and then renewing the former, the sore will become invigorated and more disposed to heal than before: when this appears to be the case, the intervention of a few carrot poultices will effect it, I think, better than any other application, and hasten the healing of the sore very considerably.

Small obstinate sores in bad habits which resist the usual means are commonly brought into a healing state by carrot poultice alone, but sometimes more readily when it is conjoined with the use of *hydrargyrus nitratus ruber*; and when such a sore is become clean and florid, the cure may be completed by dressing with a little of the down of lint loosely upon, or in the sore, and the carrot poultice over it.

There is no circumstance in the curative art more lightly, but more erroneously thought of than the healing of sores; this being supposed by many to depend upon the mere circumstance of taking off one plaster and putting on another; whereas too frequently even an apparently trifling sore (not arising from any constitutional cause and consequently requiring no internal medicine) will baffle for a long time the efforts of a skilful practitioner: and, indeed, I am well assured, that very commonly the patient is loaded with bark, &c., to the injury of his health; whilst the sore remains the same, or is becoming worse, till a mode of dressing appropriate to that particular case is hit upon.

* A poultice of bread and milk is, I believe, much fitter for this purpose than one of linseed flour.

Carrots may be procured fit for use all the year round, and though fittest when they have but just arrived at maturity, are nevertheless sufficiently efficacious at all seasons. Or they may be collected at the proper season, and preserved in sand, till the next return of them to a perfect state.

In defect of a pestle and mortar to pound the carrots, a wooden wash-hand bowl, with an appropriately-formed pestle of wood, having its base largely convex, in order to bruise the carrots more readily, may be used in their stead.

Of late years bark and Port wine have been much more sparingly used in cases of scorbutic ulcers, &c., the carrot poultice, with an ordinary restorative diet, having been found to answer best.

In large sores that require a great quantity of the carrot poultice, the outer part of the poultice may be rather coarse, but that which applies to the sore should in all cases be a perfect pulp.

The only objectionable circumstance, that I know of, respecting the carrot poultice as an application, is its disposition to become dry, particularly when used in small quantities, as in small sores, or when the carrots are not in their most succulent, pulpy state: this circumstance, however, is completely obviated, by applying a stratum or portion of the prepared carrot upon the part affected, and laying a poultice over it of linseed flour, or bread and milk, as the nature of the case may seem to require.

I have been induced to offer these observations to the attention of the public, from a conviction of the utility that may ensue from the knowledge of the efficacy of the carrot poultice, thus prepared, being made general; which has hitherto, I have good reason to think, been chiefly confined to this vicinity; where this poultice is used as well in private practice as in the Infirmary, and with the most eminent advantage.

POSTSCRIPT.

At the time this mode was originally tried here, the usual, and I suppose I may say, the constant practice in surgery was, to apply the carrots raw as before mentioned; this manner of using them being directed in all books of surgery, and the practice of it confined chiefly to the purpose of removing the ill smell or fœtor of sores.

The circumstance that led to it was the extraordinary bad cases above related; which originated in a man who had a very large cancerous sore of the arm, which became so pu-

trid and offensive, as to contaminate, as was supposed, the ward: several of the patients soon after, having sores, some even of a trifling description, which quickly assumed the putrid, scorbutic disposition above described, and several others in succession.

This affair became so serious, that it was thought advisable to have a consultation of the faculty, which accordingly took place.

The result of this was, all medical and chirurgical skill having been exhausted to no purpose, that all the wards should be fresh white-washed, and fumigated;—but still the evil continued with unabating fury.

At this juncture, having observed the effects of the carrot poultice used then raw, to exceed, in some degree, the rest of the various remedies employed, consisting, among others, of the fermenting poultice, so highly esteemed in cases of this nature; I proposed using a poultice made of the carrots boiled, hoping their efficacy might be increased thereby, attending particularly to the process and application myself; the result of which was, as before stated.

The good effects indeed of this treatment were so decided, that, although of sixteen cases which occurred in the course of the year 1794, ten terminated fatally, notwithstanding the most skilful application of the means then in use; there was not one, out of at least the same number of cases, equally dangerous, which presented themselves the year after, but what ended well under this new method.

Since that time this mode alone of applying the carrot poultice has been in use in the Radcliffe Infirmary, not only for the scorbutic or putrid kind of ulcer whenever it occurred, but for all untoward or foul sores of every description.

That the efficacy of the carrot poultice thus modified, is not generally known, even at this time, I can assert with some degree of confidence, having been repeatedly assured by a professional gentleman, that the carrot poultice, prepared in the old way, is still in general use, and without attributing any efficacy to it, beyond that which was originally allowed to that remedy. It has, however, lately found its way into some publications, but in a very vague and indeterminate manner.

Oxford, Oct. 1, 1806.

* * * The above account of the efficacy of carrots brings to the editor's recollection a similar instance of cure performed by turnips, as communicated by a friend. The following

following is the case alluded to: "A man about 50 years of age, and who had lived irregularly, had been for several years afflicted with ulcers on both legs. They at last extended from the knee to the ankle downwards, the discharge being greater and the sores worse-conditioned along the shin-bone in front of the leg. When the writer of this article first saw the man in question he was confined to bed, and had been unable to walk across the room for several weeks: he had been successively attended by all the medical gentlemen of the town in which he lived, and had undergone several courses of medicine with a view to purify the system, but without effect: his sores were dressed with the usual ointments. The application of turnip poultices was suggested to him by a country woman who came into the town on market-days. Her instructions were, that he should night and morning apply poultices of white turnips to the sores, previously bathing them with the liquor, squeezed out when the roots were boiled into pulp. The poultices were directed to be applied hot. The above directions were faithfully attended to by the patient under the inspection of the writer of this article: within the first twenty-four hours the ulcers had assumed a different appearance, and in about a week from the first application of the turnips, the ulcers were so far healed that the man was able to walk out. In a few days afterwards the sores entirely disappeared, and the skin soon resumed its usual appearance. During this period no medicine was taken by the patient; the state of his bowels not even requiring a dose of salts."

XLI. *On Crystallography.* By M. HAUY. Translated from the last Paris Edition of his *Traité de Minéralogie.*

[Continued from p. 226.]

MIXED DECREMENTS.—Decrements are so called in which the numbers of ranges subtracted in breadth and height give ratios, the two terms of which exceed unity. Such are the decrements which take place by two ranges in breadth and by three ranges in height, or by three ranges in breadth and two in height, &c. We see that their theory may be easily referred to that of decrements in which there is only a single range subtracted in one of the two directions.

INTERMEDIATE DECREMENTS.—We have seen that in the case of a decrement by one range round one and the

same solid angle O (fig. 20), the three faces produced were always on a level, and that in this case we might confine ourselves to the consideration of the effect of the decrements with respect to one of the plane angles, which concurred to the formation of the solid angle, by supposing this effect to be prolonged above the adjacent faces. In this case the decrements which take place on these latter faces are reckoned as intervening in a subsidiary manner, in order to favour the action of the principal decrement.

In general, whenever a solid angle of the primitive form undergoes decrements which tend to give rise to a facet in its place, whatever be the law of that to which we refer the production of this facet, there are always auxiliary decrements, the concurrence of which is necessary in order that the facet in question may be properly prolonged.

Now, when this decrement, which we consider in preference, takes place by two or more ranges, the auxiliary decrements which form a continuity with it follow a law entirely peculiar, the consideration of which is the object of this article.

Let AA' (fig. 32) be any given parallelepipedon which undergoes a decrement by two ranges on the angle EOI , of its base $AEOI$. It is evident that the edges of the laminae of superposition will have directions bc, rs ,* parallel to the diagonal which goes from E to I , and situated in such a manner that there will be on the edges OE, OI , two ridges (*arêtes*) of molecules comprised either between the term of departure O and bc , or between bc and rs . But, as we have said, the laminae applied on the adjacent faces $IOA'K, EOA'H$, also undergo variations or auxiliary decrements, which continue the effect of the decrement on the angle EOI . Now, such are the variations in this case, that the edges of the laminae piled up on the face $IOA'K$, have directions cg, st , and that those of the laminae which rise on the face $EOA'H$ are lineally disposed like bg, rt . For, since the lower edge of the first lamina applied on $AEOI$ coincides with bc , and as the height of this lamina answers to a ridge of a molecule, we may, with a little attention, conceive that the plane bcg , which, in one part also coincides with bc , and in another is re-

* We must conceive that the subtractions which are here represented on the quadrilateral $AEOI$ take place successively on the different laminae of superposition. The distances between each of these laminae and the succeeding one being the same with that which exists between the lines bc, rs , and all the rest similarly situated, we may, for the sake of greater convenience, refer the whole, as we do in the present instance, to the quadrilateral $AEOI$, as a kind of scale which gives the measurements of the subtractions operated by the decrement on the corresponding laminae.

moved from the base $AEOI$ in a quantity measured by a ridge Og of a molecule, is necessarily parallel to the face produced by the decrement. It is the same with the plane $rt s$; from which it follows, that if we suppress the part situated above $rt s$, we shall have a solid on which the facet $rt s$ will represent the effect of the decrement under consideration.

We may now observe that the directions cg, st (fig. 32) of the laminæ applied to the face $IOA'K$ (and the same may be said of the face $EOA'H$) in virtue of the auxiliary decrement, are no longer parallel either to the ridge or to the diagonal, but comprehended between both. *A fortiori* the defect of parallelism will take place, if we suppose that the decrement on the angle EOI of the base proceeds by three, four, or more ranges. Decrements of this kind are called *intermediate*; and we conceive that they may be referred to an infinity of different directions, according as they are more or less removed from the one or other of their limits, which are the parallelism with the ridges and the parallelism with the diagonals.

In cases similar to fig. 32, we avoid the kind of complication which would flow from the immediate consideration of those intermediate decrements, by supposing them contained in the principal decrement. But certain crystals exist, in which the three decrements considered round one and the same solid angle are all intermediate. In this case we choose the simplest for the principal, regarding the two others as auxiliary.

Fig. 33 represents a case of this kind: cn , which is the edge of the first of the laminæ applied on $AEOI$, is situated in such a manner that on the side OI there are three edges of molecules subtracted, and on the side OE there is only one: np , which is the edge of the first of the laminæ applied on $IOA'K$, indicates three ridges of molecules subtracted from $O'I$ lengthways, and two from OA' lengthways: cp , which is the edge of the first of the laminæ piled up on $EOA'H$, determines a subtraction of two ridges on OA' , and of a single one on OE .

Now it is easy to see that things go on, relatively to the different faces situated around the angle O , as if the molecules which compose the laminæ of superposition, being invariably tied together in clusters, formed other molecules of a higher order, and as if the subtractions were effected by ranges of these last molecules. Thus there would be on the base $AEOI$ a decrement of triple molecules by two ranges in height; since on one hand the quadrilater $cOnZ$,

which represents the base of a compound molecule, is equivalent to three bases of simple molecules, and as the line Op , which corresponds to the height of a lamina of superposition, contains two ridges of simple molecules. We shall even conceive that the decrement relative to the face $EOA'H$ is produced by three ranges in height of double molecules, because cOp_x contains two bases of simple molecules, and as On is equal to three ridges of simple molecules. Finally, in the decrement which acts on $IOA'K$, there is a subtraction of a single range of triple molecules in one sense and double ones in another.

Between these three decrements, that which it would seem most natural to adopt as the principal is the second, which takes place on the face $EOA'H$, because it is the one whose direction is least removed from that of the diagonal which runs from A' to E' ; or, if we please, because it is formed by double molecules, and consequently less compounded than those which are subtracted in virtue of the two other decrements. It is true that its measurement in the direction of the height is greater than that of the other decrements. But less regard ought to be paid to this element, which is common to it with the ordinary decrements, than to the differences which separate them.

We shall now give some examples of intermediate decrements. Let $OII'O'$ (fig. 34) be one of the faces of a cubical nucleus. Let us conceive a decrement which takes place on all the angles by subtractions of double molecules. In this case the edges of the laminæ of superposition will be directed like the lines dn, km, ab, eh , &c., on the hypothesis of their being a single range subtracted.

Let $E'I'$ (fig. 35) be the cubical nucleus. Let us suppose that the decrements are made parallel to the lines km, lm, kr, lr , always by subtractions of double molecules, but in such a manner that there are three ranges subtracted in the direction of the breadth, and two in that of the height, in which case the decrements will be at once intermediate and mixed. Let us moreover suppose that the edges of the laminæ of superposition, considered on the three faces situated round one and the same solid angle O , have transverse directions; in such a manner that, with respect to the face $OII'O'$, the greater number of ridges of molecules are subtracted on the side OI ; that with respect to the face $EOO'E'$, it will be so on the side OO' ; and with respect to the face $EAI'O$, it will be so on the side EO .

The effect of these various decrements will be to produce round each solid angle three faces, which will be situated

as the hevel with respect to those of the nucleus; and because the cube has eight solid angles, the secondary crystal will have twenty-four faces, which will tend to unite in fours in the form of a pyramidal summit above each face of the nucleus. But if we suppose that the decrement does not attain its limit, there will remain six faces parallel to those of the nucleus, and we shall have the polyhedron with thirty faces, or the triacontahedron represented in fig. 36.

By comparing this figure with the 35th, we shall easily conceive that the faces $km'lr$, $k'm'l'r'$, $k''m''l''r''$ (fig. 36), which answer to those of the nucleus, should be rhombs; and because the number of ridges of molecules subtracted lengthways from EO (fig. 35) is double of that of the ridges subtracted lengthways from OI, and so with the other sides; the great diagonal of the rhombus will be the double of the small diagonal, and the obtuse angle will be $126^{\circ} 52' 8''$, which is the measurement of the incidence of the faces of the dodecahedron with twelve pentagons (fig. 14) at the places of the ridges tn , pq , &c.

With respect to the faces $m'l'r'o$, $o'r'k''r''$, &c., (fig. 36) produced by the decrement, they will be all equal and similar trapezoids; and if we take for an example the trapezoid $m'l'r'o$, we shall have the angle m of $57^{\circ} 0' 50''$, the angle O of $116^{\circ} 6' 13''$, the angle l' of $111^{\circ} 50' 44''$, and the angle r' of $75^{\circ} 2' 13''$.

This form is that of one of the varieties of sulphuretted iron. Geometry has also its triacontahedron, all the faces of which are equal and similar rhombs. This solid has several interesting properties, which will be demonstrated in the part assigned to geometrical calculation.

Let us now suppose intermediate decrements towards the two lateral angles G, G' (fig. 31) of the faces of a rhomboid, and always by ranges of double molecules, *i. e.* parallel to the lines um , xy , $u'm'$, $x'y'$. It is obvious that these decrements will produce above each primitive rhombus, such as $SGg'G'$, two faces, which, setting out from the angles G, G' , will converge towards each other, and will proceed to unite on a common ridge situated above the diagonal Sg' , but inclined to this diagonal. We shall therefore have, as the complete result of the decrement, twelve faces arranged by sixes towards each summit.

Fig. 37 represents one of these solids, which results from a decrement by a simple range of double molecules, in such a manner that the edges of the laminae of superposition

tion preserve the same distances between them as on fig. 31. This solid is circumscribed to its nucleus, which is that of carbonated lime; $ab a'$ (fig. 37) indicates the direction of a section which would be parallel to the face $SGg'G'$, and which is indicated by the same letters (fig. 31), and we easily conceive that the edges of this section should be lineally disposed like those of the same lamina of superposition. The paradoxical carbonated lime discovered by M. Tonnellier is similar to this dodecahedron, abstraction being made of some additional facets.

We find here that the nucleus touches the secondary crystal by its lateral angles only, which are situated in the ridges BS', Ds', Cs' , &c., whereas in metastatic carbonated lime, which is a dodecahedron of the same kind, *i. e.* with scalene triangular faces, the lateral ridges of the nucleus are confounded with those which correspond with BC, CD, DF , &c.

This leads us to an hypothesis which will prove a remarkable property in the paradoxical dodecahedron. If we imagine six trenchant planes, one of which passes by the points C, D, F ; a second by the points B, C, D ; a third by the points G, B, h , &c., which is a way of dividing the crystal analogous to that employed to extract the nucleus from the metastatic, we shall also obtain a rhomboid, but which will exist in imagination only, since the crystal does not submit to this kind of division. Now it is demonstrated by calculation that this rhomboid is similar to that of inverse carbonated lime, the angle of which at the summit is $75^\circ 31' 20''$.

Besides, if we consider this rhomboid as a fictitious nucleus, we find that the dodecahedron might be, so far as it is concerned, a secondary form, which would result from a decrement by three ranges on the inferior edges.

Let us resume the true nucleus, and conceive that the intermediate decrement, instead of being produced by one range of double molecules, as in the paradoxical solid, takes place by five ranges in breadth and four in height. Then the secondary crystal becomes similar to the metastatic itself; and if this result is never to be met with in nature, the eye would be the more easily deceived by it, as the hypothetical nucleus would be presented under the appearance of a real nucleus.

We see by these details, to which I could give a much greater latitude, that the intermediate laws, the existence of which is in other respects hitherto confined to a trifling number

number of cases, produce forms equally simple with those which originate from the ordinary laws, and that their theory even leads to results which would deserve to be followed and developed as a simple object of curiosity.

SECONDARY COMPOUND FORMS.—We call *simple secondary forms*, those which proceed from a single law of decrement, the effect of which masks the nucleus, which touches their surface only on certain points or certain ridges; and *compound secondary forms*, those which proceed from several simultaneous laws of decrement, or from a single law which has not attained its limit; so that there remain faces, parallel to those of the nucleus, and which concur with the faces produced by the decrement in modifying the form of the secondary crystal.

Let us suppose, for example, that the law which gives the octahedron originating from the cube (fig. 20, Pl. III), is combined with that from which results the dodecahedron with pentagonal faces (fig. 15, Pl. II). The first will give rise to eight faces, which will have as centres the solid angles of the nucleus; and it is easy to see that each of these faces, for instance that whose centre coincides with the solid angle O (figs. 14 and 15), will be parallel to the equilateral triangle whose sides would pass by the points p, s, t . In the same way the face whose centre will be confounded with the angle O' will be parallel to the equilateral triangle, whose sides would pass by the points s, n, p' ; but the second law produces faces situated like pentagons cut by the sides of the triangles pst, snp' . Now the sections of these triangles on the pentagon $tOsO'n$ reduce the latter into an isoscele triangle, which has for its base the line tn , and whose two other sides pass, the one by the points t, s , the other by the points n, s . It is the same with the other pentagons; whence it follows that the secondary solid will be an icosahedron terminated by eight equilateral triangles and twelve isoscele triangles.

Fig 38, Pl. V, represents this icosahedron marked by letters whose correspondence with those of figs. 14 and 15 renders perceptible to the eye the relation between the two solids; but this icosahedron has much greater dimensions than those of the icosahedron which we obtain artificially by making sections on the eight solid angles of the dodecahedron of fig. 14, which are confounded with those of the nucleus. This increase of dimensions was necessary for preserving to the nucleus a constant volume. We shall illustrate this by a more ample development.

If we wished to obtain the nucleus of the icosahedron

of fig. 38, it is evident that we must direct the trenchant planes parallel to the ridges rs , tn , pq , &c., (figs. 14 and 38), in such a manner that they become equally inclined on the faces with which they form a junction. These planes would pass at the same time on the equilateral triangles pst , snp' , &c., and we should have the nucleus, when the whole would meet at the places of the centres of the equilateral triangles.

Hence it follows that the nucleus of which the ridges OI , OE , &c., (fig. 15), were displayed on the dodecahedron; is on the contrary entirely engaged in the icosahedron (fig. 38), excepting by its solid angles, which are points only, and are confounded, as we have said, with the centres of the equilateral triangles. This being granted, in order to form a precise idea of the structure of the icosahedron, we must conceive that the laminæ, which at first adhere on the nucleus to a certain term, decrease solely by their angles, as if the secondary solid should be simply an octahedron. Beyond this term the decrement on the angles always continuing, a new one takes place which is combined with it, and which being relative to the dodecahedron produces the twelve isoscele triangles. In this way we may conceive how the nucleus is completely inclosed in the dodecahedron, with the reserve of solid angles, because the first laminæ of superposition, which decrease on their angles only, would continue to envelop this nucleus by the portions of their edges to which the decrement did not extend. It is sometimes necessary thus to suppose different epochs at different decrements, which concur in the production of a compound secondary form, when we wish to give a detailed account of the mechanism of the structure.

According to this detail, the distance between the centres of two adjacent equilateral triangles, such as pts , qts' , (fig. 38), ought to be equal to the corresponding ridge OI of the nucleus (fig. 15), which is plainly to be seen by simple inspection of the two figures.

The result which we have developed takes place with respect to one variety of sulphuretted iron. Naturalists, at a period when the laws of structure were little understood, were led to make a kind of geometry of crystallization which operated in our manner, confounding its icosahedron and dodecahedron with those which are called *regular*, and the first of which is terminated by twenty equilateral triangles, and the other by twelve pentagons, which have all their sides equal. But theory proves that neither the one nor the other is possible in mineralogy. Thus, from the
five

five regular solids, namely, the cube, the octahedron, the tetrahedron, the dodecahedron, and the icosahedron, Nature only produces the three former, and is not susceptible of producing any thing else : among an infinity of different approximations, which she might present on the subject of the two others, she stops at that which depends on the simplest laws of decrements, in such a manner that her dodecahedron and icosahedron are really the most perfect and most regular of all the principles of geometry.

We shall cite a new example drawn from the regular hexahedral prism of carbonated lime. From what we have said (page 101) on the method of mechanically dividing this polyhedron, it is easy to conceive that its rhomboidal nucleus AA' (fig. 5) has its solid lateral angles E, O, I, K, G, H , situated in the middle of the panes of the prism $md, m'd'$; from which it follows that these angles are the points of departure of the decrements which have produced the same panes.

These decrements act at once on the three plane angles EOI, EOA', IOA' , which concur in the formation of one and the same solid angle O ; but in applying here the observation made with respect to the dodecahedron with pentagonal faces (page 213), and more particularly with respect to the regular octahedron (page 223), we can confine ourselves to the consideration of the decrement relative to one only of the three angles in question, by supposing that the face which results from it is prolonged on the two rhombs adjacent to that to which this angle belongs.

This being granted, let us refer the whole to the six angles $EOI, EHG, IKG, HGK, OIK, HEO$, the first three of which look towards the summit A , and the three others towards the summit A' . If we suppose a decrement by two ranges of rhomboidal molecules on these different angles, it will give rise to six faces which will be parallel to the axis, as we have already shown.

The laminæ of superposition, at the same time that they will decrease towards their inferior angles, will be extended on the contrary by their upper parts, so as to remain always contiguous to the axis, the length of which will of itself go on increasing. Besides, the facets produced by the decrement will gradually increase; and at the term where they meet, we shall have the solid AA' (fig. 4), where each of these facets, such as ooo , is designated by the same letter as the angle O (fig. 5), to which it is referred, since

since it is as if were the common point round which the three decrements have acted.

In proportion as new laminæ are afterwards applied to the former, the points o, o are elevated, and point O is lowered; so that at a certain period we shall have the solid represented in fig. 3, in which the faces produced by the decrement have become pentagons, such as $o o i O e$.

Things being in this state, let us suppose a second decrement which concurs with the former, and which is produced by a simple range on the upper angle $E A I$, or $H A' K$. The effect of this decrement will be to produce two faces perpendicular to the axis; and when it shall have attained the point where these same faces shall intersect the six faces parallel to the axis, which have the first decrement for the generator, the secondary solid will be terminated, and will be presented under the form of the regular hexahedral prism (figs. 1 and 2)*.

We have already said that this result was general, whatever was the measurement of the angles of the primitive rhomboid.

We now see wherefore, in the mechanical division of the prism, the section $p p o o$ (fig. 2) has its sides $p p, o o$ parallel to each other, and at the same time to the horizontal diagonal which goes from E to I (fig. 5), since the two decrements taking place, one of them on the angle $E O I$, the other on the angle $E A I$, the laminæ of superposition should have their edges turned towards this same diagonal.

In the case under consideration, and it is the most usual one, the axis of the secondary crystal is longer than that of the nucleus; so that this nucleus having its lateral angles contiguous to the panes of the prism, its summits are engaged in the interior at a certain distance below the centres of the bases. If we supposed that the two decrements had the same epoch, then, the axis of the prism being equal to that of the nucleus, the lateral angles and the summits of the latter would be tangent, the former to the panes, and the other to the bases of the prism. Finally, if the decrements on the upper angles of the nucleus had an epoch anterior to that of the other, which is the inverse of the first case, the summits of the nucleus would still be contiguous to the bases of the prism, while its lateral angles would be

* We do not pretend here to detail the manner in which the crystal has been formed, but solely the manner in which it is compounded. We shall afterwards see how we may conceive that the process of crystallization is combined with the order of the structure.

placed in the interior between the panes and the axis. This is what takes place in certain crystals, the prism of which is very short, and resembles a hexagonal lamina.

We shall conclude by an example drawn from *analogical* carbonated lime, represented in fig. 39, Pl. V. This variety has its surface composed of twenty-four trapezoids, six of which are vertical, such as $dabc$, $d'a'b'c'$, &c., twelve others, such as $c'pad$, $c'p'a''b''$, &c., arranged by sixes on both sides of the preceding, and six terminal, such as $pap's$, arranged by threes round each summit,

The former trapezoids result from the same law which gives the six panes of the regular hexahedral prism (fig. 1); the second are owing to the law which gives the carbonated metastatic lime (figs. 6, 7, and 17). By comparing fig. 39 with fig. 6, we see that the vertical faces cut those of the metastatic crystal in such a manner that they intercept the solid lateral angles E, O, I, K, &c., (figs. 6 and 7). Finally, the terminal faces proceed from a decrement similar to that which produces the equiaxis carbonated lime (fig. 18).

We cannot help being agreeably surprised, when we submit to calculation the form of this polyhedron, to see the relations of its different parts successively presented, either between each other, or with those of several other crystals.

1. In each vertical trapezoid $abcd$ (fig. 39 A), the upper triangle bad is equilateral, and its height an is double the height cn of the inferior triangle.

2. In each terminal trapezoid $psp''a''$ (fig. 39 B), the upper triangle psp'' is similar to the half of one of the faces of the equiaxis rhomboid, by a consequence of the law of decrements; and the inferior $pa''p''$ is similar to the half of one of the faces of the inverse rhomboid, which arises from the manner in which the plane of the trapezoid is cut by the planes of the adjacent faces. It results that the heights $a''r$, sr of the triangles which subdivide this trapezoid, are also to each other in the ratio of two to one, as in the trapezoid $abcd$ (fig. 39 A).

3. In each intermediate trapezoid $c'pad$ (fig. 39 C), the triangle pad is equal and similar to the fourth part PAD (fig. 39 D) of the primitive rhombus $DPD'P'$; so that the angle a (fig. 39 C) is straight, the angle dpa $50^{\circ} 46' 6''$, half of the angle DPD' (fig. 39 D), and the angle adp (fig. 39 C) $39^{\circ} 13' 54''$, half of the angle PDP' (fig. 39 D).

4. The incidence of $c'pad$ (fig. 39) on $d'b'c'd$ is precisely 135° , supplement to the half of the right angle.

5. The incidence of $psp''a''$ on $c'p'a''b''$ is $129^{\circ} 13' 54''$, supplement

supplement of $50^{\circ} 46' 6''$, which is the half of the primitive angle DPD' (fig. 39 D).

6. Finally, the polyhedron shares with the metastatic variety the property in virtue of which the mutual incidence of the faces which correspond in this variety with the trapezoids $c' p a d$, $c' p a'' b'$, are equal to those of the rhombs of the primitive form. These are the different ratios which have suggested the name of *analogical* given to the polyhedron in question.

We now see to what all the different metamorphoses belong under which the primitive form is presented in secondary crystals, whether simple or compound. Sometimes the decrements are performed at once on all the edges, as in the dodecahedron with rhombic planes, cited above, or on all the angles, as in the octahedron originating from the cube. At times they take place only on certain edges or certain angles. At others there is an uniformity between them, so that there is only a single law by one, two; three, &c., ranges, and which acts on different edges or on different angles, as it is also still observed in the solids, of which we shall speak presently. Occasionally the law varies from one edge to the other, or from one angle to the other; and this is what happens in particular when the nucleus has not a symmetrical form, as when it is a parallelepipedon, the faces of which differ by their respective inclinations, or by the measurements of their angles. In certain cases the decrements on the edges concur with the decrements on the angles to produce the same crystalline form. It also happens sometimes, that the same edge, or the same angle, undergoes several laws of decrement which succeed each other. Finally, there is a multitude of cases in which the secondary crystal preserves faces parallel to those of the primitive form, and which are combined with the faces produced by the decrements, in order to modify the figure of this crystal.

If amidst this diversity of laws, sometimes solitary, and sometimes marching as it were by groups round the same primitive form, the number of ranges subtracted was in itself very variable; if, for example, there were decrements by twenty, thirty, forty, or more ranges, as may be imagined, the multitude of forms which might exist in each species of mineral would be fit to overwhelm the imagination, and the study of crystallography would present an immense labyrinth, which, in spite of the clue furnished by theory, could with difficulty be unravelled. But the power which produces the subtractions seems to have a
very

very limited action. These subtractions are most frequently formed by one or two ranges of molecules. I have found none which went beyond six ranges*; but such is the fertility which is united with this simplicity, that, by confining ourselves to decrements by one, two, three, and four ranges, and abstracting those which are mixed or intermediate, we find that the rhomboid is susceptible of eight millions three hundred and eighty-eight thousand six hundred and four varieties of crystallization. Without doubt, among the circumstances which can determine all these varieties, there are many which are not met with in nature. But there is reason to think that discoveries of this kind will continue to be multiplied for some time to come, in proportion as a taste for mineralogy continues to be diffused, since we have hardly as yet observed 48 distinct varieties in the species of carbonated lime, which is the richest of all in crystalline forms, at least if we may judge from the present state of our knowledge.

In order to have a still more accurate idea of the power of crystallization, we must add to this facility of producing so many different forms, in commencing with a single figure, that of attaining one and the same form by different structures. The rhomboidal dodecahedron, for instance, which we obtained by combining cubical molecules, exists in the garnet, with a structure composed of small tetrahedrons with triangular isoscele faces, as we shall find under the head of this mineral substance; and I have found it in a species of fluated lime, where it is also an assemblage of tetrahedrons, but regular, and the faces of which are equilateral triangles. But besides all this, it is possible that similar molecules, subjected to a variation of laws, present identically the same result. Thus the regular hexahedral prism, which in carbonated lime generally exists in virtue of a decrement on the inferior angle, sometimes pro-

* We meet, although very rarely, with mixed decrements, which take place according to ratios such as 4 is to 9, or 3 to 8, one of the two terms designating the number of ranges subtracted in breadth, and the other the number of ranges subtracted in height; and such are hitherto the ratios of this description, that it is sufficient to increase or diminish by a unit one of the two terms, that the decrement may enter into the most common cases. For example, if in the first of the ratios which has been quoted we retrench a unit from 9, and if we add one to three in the second, each ratio will become $\frac{3}{2}$ or $\frac{1}{2}$. It results that the absolute measurement of the decrements in question does not exceed that of the ordinary decrements. For instance, $\frac{3}{2}$ and $\frac{1}{2}$ are both of them less than $\frac{1}{2}$, which expresses a simple decrement. Now it seems to me that a decrement ought to be estimated according to the absolute value of the ratio which represents it, and not according to the terms of this ratio considered independently of each other.

ceeds from a decrement on the edges adjacent to this angle. We have seen the primitive form copied as it were by a law of decrement. A nucleus even, although fictitious, substituted in imagination for the true one, would give a dodecahedron completely similar to that of paradoxical carbonated lime, by the help of a law still more simple than that which really takes place*. In the species particularly in which the primitive form has a certain character of symmetry, as when it is a rhomboid, the analogies and properties present themselves on all hands. It should seem as if geometry could not touch any term of the innumerable series of possible terms, without leaving on it the impression of some interesting verity.

[To be continued.]

XLII. *Proceedings of Learned Societies.*

PROCEEDINGS OF THE FRENCH NATIONAL INSTITUTE FOR THE YEAR 1808.

[Concluded from p. 237.]

No person is ignorant how widely Messrs. Fourcroy and Vauquelin have extended the dominion of animal chemistry.

The present year has presented us with two additional memoirs in this department of science one of them treating of animal mucus, and the other of urée.

The animal mucus transudes from all the membranes which issue from those of the cavities of the body communicating with the exterior; such as the nostrils, the trachea, the intestines, and the bladder. It differs from albumen, which forms the basis of the white of eggs, because the acids coagulate instead of dissolving it, and heat on the contrary does not produce coagulation. It differs from gelatine, because it is not dissolved in such a great quantity in water, and no jelly is formed; but it continues to be viscous and thready as long as it remains undried; it is the mucus hardened, and mixed with a fatty substance, which forms the hair, nails, and epidermis.

Urée is the colouring matter dissolved in the urine, and forms one of the principal characters of this liquid: more abundant in azote than any other animal substance, it seems

* It will be shown in the geometrical part of this work, that it is always possible to substitute hypothetically, instead of the true nucleus, a secondary form chosen at pleasure, in such a manner that the other forms become secondary in their turn with respect to this supposed nucleus.

essentially

essentially destined to free the animal body from the superabundance of this element. The two chemists in question, although long occupied in studying this substance, only procured it in its purity but very lately, and have consequently made a new display of the properties which they found it to possess in this state.

Here we ought to introduce M. Chevreuil's experiments on indigo, and those of M. Thenard concerning the action of the vegetable acids on alcohol, as also the analysis of an animal substance found in a grotto by M. Laugier; but as these complex and troublesome labours do not yet lead to any general principle proper for being inserted in a report of the present description, we are obliged to refer to the memoirs themselves, which have appeared in the *Annales de Chimie*, or in the *Annales du Museum d'Histoire Naturelle*.

Among the subjects connected with anatomy which have occupied the attention of the class, the most interesting has been a memoir on the structure of the brain and of the nervous system, presented by Messrs. Gall and Spurzheim, physicians of Vienna: these anatomists consider the cerebral organ in a very different, and in many respects in a clearer and more intelligible light than hitherto adopted. According, to them the cortical is the organ from which the nervous fibres issue, which constitute the white or medullary substance. Wherever this exists it arises from these fibres. The spinal marrow is no longer a fasciculus of nerves descending from the brain; on the contrary, the nerves called *cerebral* may be traced to the medulla elongata. The cerebrum and cerebellum themselves are only developments of the fasciculi, coming from the medulla elongata in the same way as the nerves come from it: the brain in particular derives its origin from fasciculi called pyramidal eminences, which cross each other, issuing from the medulla elongata, each of them proceeding towards the side opposite to that from which it issues; they swell for the first time when crossing the *pons varolii*, a second time when passing over the tubercles called optical layers, and a third time in those called *corpora cavernosa*, always by medullary fibres furnished by the grayish matter in these three parts, adding to those which the fasciculi originally possessed, and which there unite by acute angles, and thus ascend. The cerebellum issues from fasciculi denominated *processus cerebelli ad medullam*, which are reinforced, but once only, by fibres furnished to them by the gray matter of what is called

called the *corpus ciliare*. These two pairs of fasciculi, after being strengthened and enlarged, and after having consequently taken a divergent direction, finish by each of them spreading out into two great expansions, covered over externally with a gray substance, which, on this occasion, only deserves the name of cortical; and these expansions folded in various manners form what are called the *hemispheres of the brain*, the lobes and the vermiform process of the cerebellum. From their whole extent other medullary fibres issue, which, from the two sides of the cerebrum and of the cerebellum, converge towards the middle line, where the fibres of the side join those of the other, forming what are called *commissures*. The corpora callosa, the fornix, and their appurtenances, form the largest of the commissures of the brain. What is called the *anterior commissure* is that in particular which joins the middle lobes. The commissure of the cerebellum is composed of transverse layers from the pons (varolii). Each pair of fasciculi forming the nerves, also has commissures which serve to unite the two parts. When we remove or tear the convergent fibres which proceed to the corpus callosum, and which serve as roofs to the lateral ventricles, nothing remains under the gray substance except a medullary part composed of the origins of these convergent fibres, and of the extremities of the divergent fibres which come from the medulla elongata; and so far from the aggregate of all these fibres forming a solid mass, as formerly supposed, there is always in the middle of each circumvolution of the cerebrum and cerebellum a solution of continuity; and with some care we may unfold this portion of the white or medullary substance.

The committee appointed by the class, after having examined with the greatest care, in the dead subject, the theories of Messrs. Gall and Spurzheim, gave their assent to almost all of them which are dependent on anatomical inspection: they have even shown that several of these observations had already been made by old authors, but the generality of anatomists had not bestowed sufficient attention on the subject: the only thing in point of fact which they have disputed is, the possibility of unfolding the brain without tearing or rupturing any thing. In their opinion, there was at the most only a more trifling cohesion in the middle of each circumvolution; but they were unable to find an absolute solution of continuity.

After having bestowed on the two anatomists of Vienna

the justice which was due to them for their anatomical discoveries, the committee thought it their duty also to caution the public that there is no direct connection, no necessary relation, between these discoveries and the doctrine taught by M. Gall, on the functions peculiar to the different compartments of the brain, or with the possibility of conjecturing from the size of these divisions the intellectual and moral dispositions of individuals. "Every thing that we have examined respecting the structure of the brain (they say, in concluding their report,) may be equally true or false, without the possibility of any conclusion being drawn either for or against this doctrine, which can only be estimated by very different means."

M. Dumeril, professor of medicine at Paris, has presented an anatomical memoir to the public, in which he considers under new points of view the bones and muscles of the human and animal trunk.

After having compared the vertebræ with each other in the different regions of the spine, and in the different classes of animals, he endeavours to show that the head, so far as its movements are concerned, may be regarded as a vertebra extensively developed: not that he means to say that the head is a vertebra, which would be absurd, but merely that the facets by which the head is articulated have a resemblance with the articulating apophyses of the vertebræ; that the projecting parts which afford a hold to the muscles of the head, have a resemblance with the spinal and transverse apophyses of the vertebræ, and that the muscles which proceed from certain parts of the spine to the head are analogous with those which proceed from one part of the spine to another. After having shown these resemblances in the human species, M. Dumeril traces them into the lower animals, and shows that at all times, when there are variations in the connection of the parts of the spine with each other, there are corresponding variations in those of the spine with the head.

Passing to the examination of the muscles which act in the sides, M. Dumeril shows that, whatever are the variations in the sides of various animals, there is always nearly the same muscles which, only when there are no sides into which they can be inserted, are attached to the transverse apophyses of the vertebræ, which are then generally larger. From all this the author infers, that between the sides and the transverse apophyses there is a resemblance of connections and of functions of the same order with that which he established between the head and the vertebræ.

He makes a reflection on this subject, the truth of which is demonstrated by every animal organization with which we are acquainted.

“Nature,” he says, “is ever fertile in her resources: she never passes to a secondary combination until her primitive type and its modifications become insufficient, and never adds an organ until new circumstances require greater efforts and more powerful means.”

It is this principle which forms the basis of comparative anatomy: it is this principle which has given birth, not only to the branch of this science which compares with each other the different species, but also to another more novel and not less curious branch, which compares with each other the different organs of one and the same species. Vicq-d’Azyr had already given an example of this second branch in his *Memoire sur les Rapports des Membres anterieurs et posterieurs*. M. Dumeril on the present occasion has given another example, which may be regarded as following up the former.

M. Villars, correspondent of the class at Strasburgh, has presented two memoirs on the structure of the nerves. He thinks he has discovered, by the help of the microscope, that the envelop of the nerve is itself composed of nervous fibres: but our committee has not yet been convinced of the truth of this assertion from ocular demonstration.

Vegetable anatomy has for several years been much indebted to M. Mirbel:—the Royal Society of Gottingen made this the subject of an annual prize, which occasioned the publication of several dissertations, the chief of which were those of Messrs. Link, Treviranus, and Rudolphi, all of them professors in different German universities. These learned naturalists agree in the conclusions of M. Mirbel, adding some observations to his, but contradict him on some points. This opposition induced him to publish in his turn a defence of his theory, in which he determines it with more precision by reducing it into aphorisms, and in which he endeavours to show that the most of the objections made against him, either proceeded from his meaning being misunderstood, or from his observations having been repeated with too little care.

The same botanist has this year presented to the class a particular memoir on the germination of the grasses, and another on the distinguishing characters of the monocotyledontal and dicotyledontal plants.

In the former he has shown that the stigmata of wheat unite in a small channel which proceeds towards the base
of

of the embryo, and which serves as a conductor to the fecundation: that the cotyledon, as M. Jussieu supposed, is a pulpy substance, in which the radicle and the plumula are insensibly developed, and which is opened according to its length, in order to allow them to pass in such a way that by itself it performs the function of a sheathing leaf.

In general the cotyledons have the greatest analogy with the leaves; like the latter, they are irritable in the sensitive plant, bear hairs in the borage plant, a gland at the end in plaintains, and coloured points in the herb burnet, &c.; in short, there are real leaves in the seed. If the cotyledons, when there are two of them, are always opposite, even when the leaves of the plant are alternate, it is because the stalk cannot be developed in the seed, and the interval between the two cotyledons cannot be marked. From these multiplied connections of form and nature between the cotyledons and the leaves, M. Mirbel concludes that the number of these same cotyledons should also have its cause in some circumstance relative to the leaves, and he thinks that the monocotyledontal plants are always those whose leaves are sheathed within each other: this is evident with respect to the grasses and the *liliaceæ*, particularly if we reflect that the bulb is formed of the sheathing of the bases of all the leaves; and also with respect to several other plants of this branch of the vegetable kingdom.

Passing to the formation of the wood, M. Mirbel shows that it is always composed of fibres dispersed here and there in a cellular texture similar to the sap of the dycotyledonta, but which is formed in several monocotyledonta of these fibres at the circumference as well as at the centre: these last have consequently two vegetations; one around the outside, which increases the diameter of their trunk, and the other at the centre, which increases their density. He considers each of the fibres of the trunk of the monocotyledonta as if it answered to an entire trunk of a dycotyledon, and shows that there takes place a series of operations equally complete as in these trunks.

M. Mirbel has been rewarded for these ingenious labours by being elected a member of the Institute, in the room of the late M. Ventenat.

M. Decandolle has this year conferred additional favours on the science of botany. He has drawn up a memoir on plants with compound flowers, in which he forms a separate family of those whose flowerets have two unequal labia,

and in which he distributes those denominated *cynaroccephali*, according to the lateral or terminal insertion of the grain.

In general the present year has shown that botany is cultivated in France with more ardour than ever. The memoir of M. du Petit-Thouars on the family of the *orchideæ*, the forerunner of a large work on the natural families of plants, which this eminent botanist is about to publish,—the memoir of M. Longchamp on the *narcissi*,—the monography of the *eryngia*, by M. de la Roche,—have added greatly to the fame of their respective authors.

M. du Petit-Thouars in particular has come to the resolution of publishing his theory of vegetation, founded on the development in two directions, which he admits in the shoots, and of which we have already given an idea in preceding reports.

M. Ventenat terminated his laborious career by a memoir on the genera *samyda* and *cæsaria*, of which he makes a new family closely allied to the *rhamnoides*: this last effort of his genius was intended for the continuation of the *Jardin du Cels*, a work which his death interrupted.

The history of animals has been enriched by the completion of M. Olivier's work on the *coleopterous* insects, and by his description of all the gelatinous animals brought together by Linnæus under the head of *medusæ*. M. Peron, who collected a very great number of them in his voyage to the South Seas, adding his own observations to those of his predecessors, makes this family amount to upwards of one hundred and fifty species. It is perhaps necessary to give M. Peron's words on this subject when detailing the singularities of these zoophytes: "Their substance seems to be nothing but coagulated water, and nevertheless they exercise the most important functions of life; their multiplication is prodigious, and yet we know nothing of their peculiar mode of generation; they are sometimes several feet in diameter, and 50 or 60 pounds in weight, and their nutritive system escapes our view; they execute the most rapid motions, and the details of their muscular system are imperceptible; they have a kind of very active respiration, and its actual seat is a mystery; they appear extremely feeble, and considerable numbers of fishes make them their daily prey: the zoophytes in question shine in the darkest nights like globes of fire; some of them burn and render torpid the hand which touches them,—the principles and agents of these two properties remain still to be discovered."

The

The medusæ, properly so called, have a gelatinous body nearly of the form of the top of a mushroom, which M. Peron calls umbrella, after the example of Spallanzani; but they differ from each other, in as much as some of them have a mouth and others want it; some have several mouths, and in others there is a production under the umbrella in the form of a pedicle.

M. Peron from these characters has formed a tree of divisions and subdivisions, in which all the medusæ in existence must necessarily fall to be classed, and in which he has placed all those with which he is acquainted. Faithful and accurate paintings, executed by his fellow-voyager M. Lesueur, explain all that variety of forms and colours so necessary for subjects of natural history.

To these inquiries into external characters, M. Peron has added some interesting details on the internal structure of these animals, and particularly the genus called *rhizostomum*. M. Cuvier had so denominated it, because he supposed that the filaments attached to its tentacula were so many suckers, and that the nourishment thereby inhaled proceeded to a central cavity, from which it was distributed to the whole body by an infinite number of vessels arranged very regularly, and multiplied particularly in the edges of the umbrella. The four apertures in the sides of the base of the pedicle appeared to M. Cuvier to be the organs of respiration.

M. Peron on the contrary, having observed several living rhizostoma, and having seen them take in some small animals by these four apertures, and suck them in towards the four cavities to which they lead, is of opinion, that these are four distinct mouths and stomachs, and that the large vascular apparatus, which fills the pedicle and the edges of the umbrella, is with much more probability set apart for the office of respiration, as it is almost always filled with air.

M. Cuvier has this year instructed the class with respect to certain species of reptiles, the bones of which have been found buried in the earth. All of them had been regarded as belonging to crocodiles, and even peculiar to a crocodile of the Ganges called the Gavial genus; but there are lizards of the *safeguard* or *tapinambis* species, which belong also to the Gavial genus, although they have distinctly marked differences in their respective characters.

What is most singular with respect to these fossil bones of reptiles is, that they are found at a much greater depth than those of land animals.

The environs of Maestricht also contain the bones of a great animal of that family, which some regard as a fish and

others as a crocodile, M. Cuvier has endeavoured to show that it is a *monitor*, although a giant of its kind. It is upwards of 25 feet in length; the tail is short in proportion, but broader than that of the other species, and probably formed a powerful rudder; as every thing favours the suggestion that this animal was strong enough to live on the surface of the ocean: its bones are generally found among those of large tortoises and shell-fish.

Mr. Jefferson, president of the united states of America, has sent to the class a fine collection of fossil bones dug up on the banks of the Ohio in North America: the greatest part belongs to the huge animal improperly called the mammoth by the Americans, and to which M. Cuvier has given the name of *mastodontus*; but there are several bones in the collection belonging to the true mammoth of Siberia. These two gigantic animals seem therefore to have formerly inhabited the whole northern hemisphere.

We cannot account for the extirpation of these enormous races, and of so many others that have been victims of the same catastrophe, without being completely acquainted with the strata in which these bones are buried, as well as their succession and nature. This is what has been attempted by Messrs. Cuvier and Brongniart in the environs of Paris. So far as they have as yet been able to examine the soil in the neighbourhood, they have found it to be composed of several strata evidently different. The lowermost stratum is an immense body of chalk, which extends to England, and contains nothing but unknown shells, several of which belong to unknown genera. Above this chalk there is a stratum of clay, which does not contain any organized body. In several places are to be found those strata of calcareous stones which are employed in building: they are interspersed with shells, most of which are unknown, but they belong to genera with which we are acquainted, *i. e.* they resemble the sea-shells of the present day.

Hillocks of plaister-stone are thrown as if by chance, sometimes on the clay, sometimes on the calcareous stone, and contain abundance of bones of land animals entirely unknown, the skeletons of which have been described by M. Cuvier. In these beds of chalk and the clay which immediately covers them, the shells are those of fresh water, but the upper strata contain salt-water shells also.

An immense heap of sand without any organized body crowns all our eminences; and, what is more remarkable than any thing else, the highest stratum, namely, that

which covers the whole, abounds in fresh-water shells. It is only in the bottoms of valleys, or rather in the cavities of this superficial stratum, that we find the bones of elephants and other animals whose species we know, but whose genera we are not yet acquainted with.

It results, therefore, from the observations of Messrs. Cuvier and Brongniart, that the sea, after having for a long period covered France, and having several times changed the inhabitants and the nature of the soil, gave way to a temporary deluge of fresh water, during which chalk was deposited; but the deluge having returned, at least a second time, seems to have destroyed the beings which had been propagated: at this period the *palæotherium* and the *anoplotherium* must have disappeared. Every thing tends to render it probable that this deluge made its appearance a third time, and on this occasion perhaps the elephants disappeared.

By similar investigations in other countries, we may be enabled to determine if there be any thing general in the arrangement of the strata, and of the organized bodies which they contain; and we may thereby succeed in fixing our ideas on the succession of the catastrophes which have brought the surface of our globe into the state in which it now is.

M. Sage has given us some analyses and descriptions of certain stones, such as chalcedony, common agate, and that kind of volcanic stone called *gaestein*: he has also communicated some experiments on the cohesion which lime contracts with various substances,—experiments which will be useful in ascertaining the composition of various mortar.

M. Brochant, mining engineer, has communicated some observations relative to strata much more ancient than those in the environs of Paris, and which M. Werner has designated by the name of *soils of transition*, because they are placed between those primitive mountains anterior to organization, and those secondary strata filled with the bones of animals. Most of them are composed of fragments of primitive soils united together like pudding-stones by various cements, and here and there we now begin to find remains of animal and vegetable organizations.

Saussure had already noticed these soils in the Alps; but M. Brochant determines them with more precision and follows them more into detail, chiefly along the Alps on the side of France.

M. Lescallier, the maritime prefect of Genoa, has considered

sidered mountains under another point of view, in a memoir on the climate of Liguria, in which he shows, by various examples, that this country, protected against the north winds by the Apennines, is more favourable to the plants of warm countries than any other of the same latitude, because the winter there is milder, although of longer duration, while the summer is cooler on account of the vicinity of the sea and the snow.

The natural history of the department of Doubs has been embraced in all its parts by M. Girod-Chantrans, in a work submitted to the judgment of the class, and in which he gives the catalogue of all the species of plants and animals which he could find, with descriptions of the mountains, mineralogy, springs, and other phænomena. It is much to be desired that all the departments of the empire were described with the same precision.

Every person knows that dropsy, generally considered as the effect of an obstruction, is treated by aperients and sharp purgatives, given under every different form. A memoir from the pen of M. Departz has treated this regimen as rather too much followed. He has cited a number of observations which, in his opinion, prove that many cases of dropsy, particularly those produced by mental anxiety, depend on a too great contraction in the vessels, and require mild evacuants. He even asserts, that this kind of dropsy is more common than is generally supposed, and that it deserves all the attention which practitioners can bestow.

M. Leguin, who, without being a medical man, has been occupied by a praiseworthy zeal of furnishing new agents to medicine, seems to have particularly attached himself to combat intermitting fevers, which are so common and so direful in all countries. He has long treated them with gelatine, and assures us he has obtained the most decided success. This year he tried albumen, and found it very successful also. He has already cured forty-one patients, by giving them, at the time of the fit, the whites of three eggs diluted in warm water with a little sugar. In his opinion this remedy, as well as gelatine, is the more convenient because we may lay it aside if the first fits which succeed its exhibition are not milder.

M. Portal has this year read an account of a patient who laboured under the various symptoms of *Phthisis pulmonalis*, added to some others, the cause of which was unknown. On opening the body, there was an abscess in the liver as well as in the lungs, and both abscesses communicated through an opening in the diaphragm.

M. Pelletan

M. Pelletan has presented a work on internal aneurisms. These diseases, although almost always mortal, may be checked in their progress when care is taken to debilitate the patient by frequent phlebotomy and other means. This treatment, suggested by Valsalva from an idea of Hippocrates, has been successfully resorted to by M. Pelletan; and with three patients he succeeded in performing a radical and unequivocal cure.

Some polemical writings on the *Plica polonica*, exchanged between M. Chamseru and the adversaries of his opinions on the subject, having led to nothing further than what we last year communicated, we wait for more conclusive observations before we resume the subject.

We now proceed to the agricultural department, with which we shall close our report.

The *Projet du Code Rural*, drawn up by order of his majesty, has been submitted to the examination of commissioners chosen from every department of the empire. This work is intended to guard the farming interest of France against every kind of depredation or deterioration.

M. Tessier has also by order of the government edited a popular course of instructions relative to the culture of cotton in France, and which has already been attended with success in the southern provinces.

M. Bosc has read a memoir, at once botanical and agricultural, in which he describes 28 species of ash trees long cultivated in the neighbourhood of Paris, which were either not known to naturalists or confounded with each other. Several of these species, indigenous of North America, are large trees, which may become very useful to the arts by the pliability and elasticity of their wood, qualities in which they are superior to the common ash-tree.

If we refer to the memoirs on establishing the sugar-cane in France, by M. Cossigny,—to the paper by M. Morel de Vincle, on the method of increasing Merino sheep,—to the chemical principles of dyeing, by M. Chaptal,—and to the two volumes of *Annales*, published this year by the professors of the museum of natural history; it will be evident that the science of agriculture has not been neglected.

Three new substances added to chemistry, one of which had been in vain sought after for twenty years, the two others scarcely supposed to exist,—more precise ideas on the structure of the most important organ of the animal body,—a more positive knowledge of some parts of the world,—a multitude of organized beings added to the numerous list
already

already in our possession; notions more accurate respecting their formation;—succours still more valuable contributed by chemistry and natural history to rural and domestic œconomy; valuable observations in medicine and precious remedies,—All these have we this year to enrol in the annals of the Institute, as the Romans enrolled the conquests of the republic; and we have a right to boast in this manner: for although all these discoveries may not have proceeded directly from members of our body, yet we are not strangers to any of them, since by our diligence and labours we have proved their reality.

XLIII. *Intelligence and Miscellaneous Articles.*

MESSRS. 'LONDONS' PROCESS FOR PURIFYING MURIATE OF SODA*.

THIS process consists in purifying or refining muriate of soda, whether obtained from rock or fossil salt, brine, springs, sea water, or from any other source, by fusion, or by heat, or calcination; and by the application of soda, its nitrate, sulphate, carbonate, or any other of its combinations; potash, volatile alkali, lime, or their sulphates, nitrates, carbonates, or other combinations; or by the addition of any other material or re-agent that will effect the decomposition, precipitation, or separation of the whole or part of the earthy or metallic salts combined with the muriate of soda.

The muriate of soda (common salt) with the necessary re-agents is to be put into a reverberating furnace, and such a degree of heat applied as will fuse the muriate of soda, which being kept in fusion a sufficient length of time, the earthy and metallic parts are decomposed, precipitated, or separated; and the purified muriate is drawn off or taken out into proper receiving vessels as long as it continues to come off clear, leaving the sediment or impure residue at the bottom of the furnace.

The muriate of soda thus prepared may be broken into any sized grains or pieces required.

If the muriate of soda be not required in that state of purity in which it may be obtained by the above process, the expense of re-agents need not be incurred. By mere

* Extracted from their specification, a patent having been granted for their process.

fusion as above described, a portion of the earthy and metallic salts, with which it may be contaminated, will be precipitated, and the purer muriate may be separated as already described.

The muriate of soda left mixed with the precipitated residuum, is afterwards recovered by solution and evaporation.

Salt so obtained, may be refined by the modes usually practised with rock salt, viz. solution, deposition, and evaporation; and salt so refined will (say the patentees) be purer and more fit for curing fish, and provisions for common use, than any small salt at present manufactured, and may supersede the necessity of importing foreign or bay salt altogether.

M. Chladni, so well known for his various researches in the science of acoustics, has invented a new musical instrument, to which he gives the name of clavi-cylinder. The imperial conservatory of music at Paris have made a very favourable report on the subject of M. Chladni's invention, which they describe as resembling the flute and clarionet in the high notes, and the bassoon in the lower keys. The report candidly states, that the clavi-cylinder is not so well adapted for lively strains as for solemn music; but its effects in the *orecendo* and *diminuendo* are highly praised.

M. Chladni himself describes his invention in the following terms: "The clavi-cylinder contains a set of keys, and behind this a glass cylinder seven centimetres in diameter, which is turned by means of a pedal and a loaded wheel. This cylinder is not the sounding body, but it produces the sound by friction on the interior mechanism. The sounds may be prolonged at pleasure, with all the shades of *orecendo* and *diminuendo*, in proportion as the pressure on the keys is increased or diminished. This instrument is never out of tune. It contains four octaves and a half, from *ut*, the lowest in the harpsicord, up to *fa*."

William Jackson Hooker, esq., F.L.S., of Norwich, has lately returned from Iceland, where he spent the summer in investigating the natural history of that interesting country. He travelled with a retinue of Icelanders as far up the country as the perennial snow would permit, collecting numerous specimens of quadrupeds, birds, insects, plants, minerals, &c., making drawings of the most important objects of curiosity, and also purchasing, in different places,
many

many Icelandic books, weapons, dresses, &c., at great cost. Mr. Hooker visited the Geysers or hot spouting springs, and pitched his tent for some time in their neighbourhood, watching the most favourable opportunities for making drawings of them.

We regret to add, that nearly the whole of this gentleman's labours were lost, by the disastrous circumstance of the vessel in which he embarked for London taking fire soon after they were out of sight of the island, and being burnt to the water's edge. The crew and passengers were saved by a vessel which providentially came in sight soon after the fire began.

Mr. Hooker, after whom the president of the Linnean Society named his new genus of mosses, is already well-known to the lovers of natural history as the discoverer of *Buxbaumia aphylla*, as well as by his scientific drawings for the valuable work on Fuci, by his friend Dawson Turner, esq., of Yarmouth; and his descriptions of several new mosses gathered by Dr. Buchanan, during his journey to Nepal, published in the last volume of the Linnean Transactions.

BEEET-ROOT COFFEE.—We have frequently had occasion to mention the progress made on the continent in extracting sugar from beet roots; and it now appears that the yellow beet root, when cut into slices and kiln-dried, furnishes an excellent substitute for coffee, particularly if ground along with a small quantity of Turkey or West India coffee. It requires much less sugar than the foreign coffee, and is said to be much stronger. M. Vinnen of Coblenz claims the merit of having discovered this new application of beet-root. He cautions his readers against stripping the plant of its leaves for feeding cattle as is generally practised, and which not only injures the growth of the plant, but materially alters the qualities of the juice.

Great exertions are making in ever department of France to produce substitutes for West India sugar, and prizes are daily offered by the various æconomical societies of the continent for the discovery of the most proper material for that purpose. The saccharine matter of the grape has been the chief subject of the recent experiments of the French chemists.

MINERALOGY OF THE BRAZILS.—By letters lately received from Mr. Mawe, from Rio de Janeiro, dated the 15th of August, we are informed that he is honoured with the prince-regent's permission to travel and make observations in the mining district of the Brazils: he has already passed some months in the government of St. Pauls, where he discovered a variety of fine clays for the purposes of porcelain, &c., and is lately returned from the mines of Canto Gallo. The gold mine of Santo Rita is between two rocks of *sparry limestone*, a substance not before known to exist in that country, nor would they believe it until they saw it burnt into lime. These districts, until now unexamined by any mineralogist, (in a country so rich in precious productions,) cannot fail to be highly interesting to the lovers of natural history.

The following directions for training messenger pigeons are extracted from an Arabic work printed at the imperial press at Paris, under the title of "The Messenger Pigeon more rapid than Lightning, and swifter than the Clouds; by Michael Sabbagh."

"As soon as the young pigeons are fledged, they must be taught to feed from a person's hand, and to drink from the same person's mouth. For this purpose take up the young pigeon, and with your hand gently throw back its head, open the bill, and put two or three grains of corn into its mouth. When you think it has eaten enough, take some water into your mouth and make it drink by introducing its bill: afterwards place it on the floor and play with it, teaching it to follow you. This exercise ought to be repeated twice or thrice a day, with the view of accustoming the animal to be handled. When the pigeon is strong enough to fly a little, if it be a male, you should place it beside a female which has received the same training.

"As soon as they can fly well, they may be put into a cage and sent to the place to which it is intended they should afterwards carry messages. The cage ought to be uncovered, that they may see the road. As soon as they have arrived, the owner of the place to which they are sent will keep them shut up for a month at least, taking care to play with them and handle them every day. It will be proper to continue this treatment for two months, when the birds will have been accustomed to this second place of residence: one at a time may then be let loose, and not both together, for the following reasons:—1st, If you set

one of them only at liberty, nothing will stop it on its way, neither corn nor trees will detain it for a moment, while the desire of returning to its companion will quicken its speed. 2dly, If any thing has occurred to detain it, either from its having visited a strange pigeon-house or any other cause, you have only to turn out its comrade, which will soon bring it back. 3dly, If you have a male without a female, or *vice versâ*, there is reason to fear that the bird will on some occasion meet an agreeable companion, and of course neglect its master and its errand. For these reasons I think it indispensable that messenger pigeons should always be paired.

“ As soon as a pigeon has arrived with a letter at the place of its destination, it should be immediately set at liberty once more with the answer. If kept long from its mate, it would in all probability die of grief, or refuse to undertake a similar mission in future.

“ After the letter has been attached in the way to be subsequently explained, the person charged with dispatching the pigeon ought to carry it to a distance from the houses into the fields, directing his face towards the place to which the letter is to be sent. The first time a pigeon is employed on this service, it will be proper to follow it for about a quarter of an hour, lest it should alight on some tree, from which it must be driven.

“ Some persons are in the habit of attaching the letter to the male pigeon only, and letting him loose along with a female belonging to the place to which he is to be sent. When both arrive at their place of destination, the female must be confined and the male sent back to his own mate with the answer. This precaution is had recourse to in order to accustom the pigeons to go and come.

“ The letter entrusted to the pigeon ought to be written on very fine paper: all superfluous words must of course be avoided; the letter is generally placed flat under the wing, but in my opinion it would be more advantageous to fasten it to one of the sides; in the first place, because the weight of the letter would be less felt; and secondly, it would be less liable to fall by the flapping of the wings when the animal flies.

“ By placing the letter under the wing it is preserved from rain and other accidents. It may be fastened by a small pin to one of the strongest feathers, the pin being passed through the letter and fastened at both ends by a piece of thread crossed over it. The point of the pin should
be

be kept outwards that the sides of the bird may not be pricked. Care should also be taken that no part of the letter should hang out, lest the flight of the pigeon be retarded.

“The nest or pigeon hole should be so constructed that the bird may be laid hold of without any struggle, or without being fatigued.”

OIL OF CABBAGE SEED.—M. François de Salingue, of Halverstadt, manufactures a refined oil with the seeds of the cabbage plant (*Brassica campestris*). Those chemists who have examined this new production, describe it as possessing the following properties :

1. It equals in point of yellow colour and purity the finest oil of Provence.
2. It is inodorous, and has a taste of almonds, which distinguishes it from the oil of rape-seed.
3. It may be substituted for olive oil in sallads, and for other domestic uses.
4. When used as lamp oil, it gives a bright flame without smoke. It is also very æconomical; a given quantity will be consumed much more slowly than the same quantity of rape oil within the same time.

LIST OF PATENTS FOR NEW INVENTIONS.

To John Jones, of Birmingham, Warwickshire, gunlock and -barrel maker, for certain improvements in the manufacturing of skelps for fire-arms.—Sept. 28, 1809.

To William Bundy, of Camden Town, Middlesex, mathematical instrument maker, for his new method of heading pins.—Sept. 28.

To John White the younger, of Whitehall Wharf, Westminster, for a certain substance which is capable of being converted into statues, artificial melting pots, bricks, tiles, sugar-bakers' pans, chimney pots, garden pots, and every description of pottery.—Sept. 29.

METEOROLOGICAL TABLE,
 BY MR. CAREY, OF THE STRAND,
 For October 1809.

Days of the Month.	Thermometer.			Height of the Barom. Inches.	Degrees of Dryness by Leslie's Hygrometer.	Weather.
	8 o'Clock, Morning.	Noon.	11 o'Clock, Night.			
Sept. 27	57°	61°	42°	29·40	15	Stormy
28	42	55	40	·82	10	Stormy
29	40	54	43	·95	41	Fair
30	44	57	50	·85	0	Rain
Oct. 1	50	58	53	30·15	43	Fair
2	52	61	57	·30	5	Small Rain
3	58	63	58	·34	10	Cloudy
4	56	62	51	·16	40	Fair
5	48	60	55	·09	42	Fair
6	54	61	50	·09	46	Fair
7	49	60	45	·10	38	Fair
8	46	55	42	·11	39	Fair
9	44	50	40	·08	36	Fair
10	40	49	44	·01	44	Fair
11	45	51	41	·01	40	Fair
12	40	49	38	·05	31	Fair
13	34	49	36	·15	43	Fair
14	32	51	37	·22	29	Fair
15	35	48	40	·28	27	Fair
16	46	56	53	·08	15	Cloudy
17	53	59	55	·07	15	Cloudy
18	53	59	56	·07	10	Cloudy
19	55	59	56	·11	6	Cloudy
20	52	54	52	·11	8	Cloudy
21	52	57	50	·08	15	Cloudy
22	51	56	51	·03	17	Cloudy
23	53	56	54	29·92	21	Cloudy
24	50	60	51	·82	19	Fair
25	49	56	52	30·22	26	Fair
26	52	63	56	·30	21	Fair

N. B. The Barometer's height is taken at one o'clock.

XLIV. *On the Ascent of Salmon over the Elevations in the Course of Rivers, called Salmon-Leaps.* By JOHN CARR, Esq., of Manchester.

To Mr. Tilloch.

SIR, IN natural history the correction of an old error is sometimes of equal importance with the development of a new truth; but when the latter is made productive of the former, the case is still more interesting. I have to offer to your notice, Mr. Editor, an instance of this description in the natural history of the salmon; and if you think it deserving a place in your respectable monthly repository, it is very much at your service.

The natural element of salmon certainly is salt, not fresh water. It is in the sea only that they acquire their growth, and attain that vigorous strength and muscular energy in which they are not, perhaps, excelled by any other animal of equal weight and bulk. Nature, however, has determined that they shall propagate their species only in fresh water; and it is for that sole, but important purpose, that they quit the ocean and ascend rivers and streams almost up to their very sources, in every country where they abound.

Summer and autumn are the seasons when they enter fresh water in the greatest numbers, and when the shallowness and transparency of the streams necessarily occasion the period of their ascent being limited to times of flood only. But at these times such are the instinctive energies which impel, and the muscular powers which enable, them to advance, that no natural or artificial barrier across the streams, *over which a sufficiency of water tumbles*, has ever yet been known to arrest their progress upwards; and if at these times their course is ever stayed, it results less from the height or other difficulty of the opposing obstacle, than from a deficiency of that due proportion of the descending fluid, which is requisite to allow the natural force to the exertion of their wonderful powers.

From the elevated ascent of these extraordinary fish, many waterfalls and cascades have acquired the name of *salmon-leaps*. They are numerous in the united kingdom, being found in Wales, Ireland, and Scotland; and some are of such a height as to call forth the admiration and astonishment of every person who views them. No one has ever seen a salmon actually leap over any of these elevations, and the proof of their doing so rests wholly on the

circumstance of the fish being found in abundance above the falls, and the indubitable certainty that they must have passed them. I have never seen, in any publication, an explanation of the manner in which salmon actually do ascend these heights, and the general opinion certainly is that the fish really leap over them.

This notion of leaping is probably encouraged by observing, that when the rivers are but partially flooded, the salmon actually do leap up against the falls. Great numbers of them may be seen thus employed for whole days together; but none will ever be observed to leap higher than about three feet, whereas to the top of the fall is probably many times that height.

At some of these leaps, indeed, it requires only a simple inspection, and a moment's reflection, to perceive that no animal unprovided with wings could possibly clear them in the manner of a leap. This impossibility, however, has been very little attended to; and in some of the older publications on the subject, the very manner of the leap has been described, by gravely affirming that the salmon coils himself up in the form of a ring, and seizing his tail in his mouth, by the strained violence of an elastic spring overtops the high ascent in an aerial somerset.

So readily accessible is the marvellous in minds untutored by reflection, that this most extravagant absurdity was once a very general opinion, and is still credited by many. The analogy of a bent cane flying off with an elastic bound was deemed sufficient both to illustrate and establish the fact, and no consideration was paid to the awkward circumstance of the tail and mouth of the fish being at right angles to each other.

It is now proper to say what is the real mode by which salmon actually do pass over the heights in question: and this I shall speak, not from any speculative guess or reasoning on the subject, but from my own personal observation, having frequently seen the transaction take place. In every instance then, where salmon ascend those *leaps*, they do it by *swimming* up, and over the face and brow of the waterfall, penetrating through the interior of the descending body of water, by means of their vast muscular power operating on the action of their tail.

They never pass these *leaps* but at times when the stream is very much flooded, and a large unbroken mass of water is descending. Without such a solid column of water their ascent would be physically impossible. At these times the water, as in all cases of flood, is highly discoloured; and

so dartingly quick is the ascent of the fish, as rather to resemble the transient gleam of a passing shadow over the water, than a real substance penetrating through it. These are probably the causes of all the obscurity in the case. Indeed, when standing at the distance of only a few yards, it requires a very strong and steady eye to catch the evanescent figure of the ascending fish, and beholding can alone convey any adequate conception of the rapid facility of the passage upwards. In a few instances I have seen the salmon beaten back, on making the turn at the top; but that is uncommon, and it rarely occurs that the effort of the fish miscarries.

This extraordinary ascent of salmon up a perpendicular column of descending water must of course have its limitation; but it would, I believe, be difficult to assign its limits, or to discover an instance where it fails under admissible circumstances. I know but of two cases wherein salmon can be prevented from ascending rivers which they frequent in furtherance of that great and imperious duty which nature imposes on them, and these are when the stream is made to pass through apertures too small for the admission of the fish, or when it does not descend over a fall; without regard to its height, in a sufficiently consolidated and unbroken mass to allow of the salmon swimming up it.

After accomplishing the great object of their journey into the fresh water, the salmon again descend to the ocean, but so shrunk and wasted by their detention in the rivers, where there is either no proper or no sufficiency of food for them, as scarcely to retain a third of their original weight.

The spawn is deposited in holes purposely made in beds of gravel, and covered with successive layers of the same materials; and as it becomes animated each individual liberates and provides for itself. Their growth is singularly rapid, arriving at six or eight inches in length early in spring, at which season, the whole, then become immensely numerous, follow the old fish by descending with floods to the sea.

In Cumberland is pursued a very singular species of aqueous salmon hunting, which is not, I believe, practised in any other part of the kingdom. On the flat coasts of the sea, and adjacent to the mouths of the rivers, as the tide retires, some of the fish remain in the shallow water, that is in water two or three feet in depth. They can be readily perceived at some distance, from the swell of water

which rises over them when in motion. A man mounted on a horse accustomed to the sport, and grasping a spear made for the purpose, advanced towards the fish, and as soon as the latter has discovered its pursuer and is making off, a complete chase takes place between the horseman and the salmon. As soon as the man finds himself nearly up with his game, the spear is thrown with such force and dexterity as seldom to miss, and the salmon, entangled with the weight of the spear, soon becomes exhausted. So very powerful is the salmon in water, that were the man to strike it while he grasped the spear in his hand, he would instantly and inevitably be dragged from the horse.

I am, sir, your most obedient servant,

JOHN CARR.

Princess Street, Manchester,
Nov. 4, 1809.

XLV. On the Breeding of Fish, and the Natural History of their Generation.

[Concluded from p. 272.]

Extract from the Hanover Magazine, No. 62, August 5, 1765.

On the Breeding of Trout.

“IN the 23d Number of this Magazine, of the year 1763, was given a short account of the breeding of trouts*: as we have since received a more complete natural history from the inventor himself, we hope it will not be disagreeable to our readers to have a repetition on the same subject, as the discovery really deserves some attention. The fishery of this nimble and cautious animal is carried on in a destructive manner, and commonly at the spawning-time, when root and branch are destroyed together. But now we enjoy the pleasure of eating trouts, and have them replaced many hundred fold; and have the spawn secured from the danger it is exposed to in the open ponds. If the system of the inventor should displease, it must be considered that he does not mean to offer a new theory of generation, but a method of producing a greater number of fish for the table; which last may be obtained without knowing the nature of the first. Something similar to this is to be seen in C. F. Lund’s Treatise on the Generation of Fishes in in-land Seas or Lakes. See the Memoirs of the Swedish Academy of the year 1761, vol. xxiii. page 181.”—We

* See p. 268 of our present volume.

now proceed to give the inventor's discovery in his own words :

SIR,—As I observe from the Literary Mercury of Altona, No. 20, 1764, that the Royal Prussian Society of Sciences have taken into consideration my invention of breeding trouts and salmon, wherein I have observed that the lecture thereon must have been pronounced on an indifferent and partly an erroneous system ; and that a Northern Society of Sciences has, in an Essay on the natural Generation of Fishes, placed that which I had observed, after frequent experiments, among the *desiderata*;—at Petersburg and several other places they have considered this method of an artificial breeding of trout and salmon, as a false chimæra. I am aware that naturalists are frequently furnished with matter to search for further discoveries after an invention is made public, and that critical examinations will clear up any doubtful opinions on a firm basis ; I have therefore been led to further experiments, to find out the true causes ; and how duplicate bodies, in the human as well as in the whole animal creation, are generated ; which, though they have a double body, yet have but one stomach. I have thought it a duty incumbent on me to lay my observations on this subject, as well as on others, before the public. It would be needless, and not to my present purpose, to mention every trifling experiment which I made within the first sixteen years before my conclusions were drawn, and in twenty-four years more afterwards, on the artificial increase of trouts and salmon. Perhaps I may be induced hereafter to give more circumstantial accounts on this subject.

The box, or trough, or water-bed, in which the eggs animated with the milt or sperm of the male trout are scattered, needs no particular form ; yet it will not be unnecessary to give a description how my own are made.

§ I.

(1) I had boxes made of several woods, (but I found oak to be the best,) of about twelve foot long, one foot and a half wide, and six decimal inches deep.

(2) At the head of the trough, where the water is to run in, is laid a thick board about two and a half or three inches thick, about a foot wide, and as long as the trough is wide ; in the middle of this board is made a hole six inches long, and about four inches wide in the clear, with a rabbet on all the four sides of this hole about an inch and a half wide and deep, so as to admit a square frame with an aper-

ture of six inches by four inches, or of the same size as the hole; which frame must be covered with a brass grating (for iron will rust) of a moderate strength, and close enough to prevent the smallest water-mouse from passing through; otherwise all the spawn and young fry will be in danger of being devoured by them.

(3) Near the middle of this box or trough lay another piece of thick board across, as long as the width of the trough, and about six inches or more wide; which, when nailed upon the edges of the side pieces, will keep them more steady and firmer.

(4) Let the lower end-board, where the water is to run off again, be at least three inches thick, as the greatest pressure is against it; have an opening cut in the top six inches wide and four inches deep, and a rabbet made on the outside and another on the inside, deep enough to leave at least an inch thick of the solid board in the middle, and wide enough to admit a frame with a brass wire grate like (2) on the outside, which can be shoved in from them; the wires should not be above a line and a half asunder, like those at the top, and for the same reason mentioned before. In the inside, opposite this opening, shove a bit of board in in its groove downwards, to stem the water either entirely, or to regulate its running off, according as you find it necessary, or to pull it entirely out when the whole of the water is to run off.

(5) There must be two strong covers, one between the two cross pieces described in (2, 3), and the other below the middle cross-piece quite to the lower end (4); both covers must be fastened behind with strong hinges, and before with handles to lift them conveniently up by; and as these boards are apt to warp, on account of the water within and the air without, it is requisite to have each clamped with two or three cross-pieces.

(6) If you think fit to give the young fishes more air than what enters at the two brass grates, you may have in each cover a hole made of the same size, and guarded with a brass wire grate, as (3), and for the same reasons: I have done this out of precaution, but have found it in the end to be unnecessary.

§ II.

(1) Spring-water out of rocks or stony ground is the properest for breeding trouts or salmon; but where it is not to be had, any other spring-water may do, provided the current is strong enough to prevent freezing in cold frosty weather.

(2) If

(2) If the spring has not fall enough, you must raise a dam round it, one or two feet higher than the top of your trough; convey the water from thence through a pipe or gutter to the first grate in the opening on the head-part of the trough, § I. (2), of one decimal square inch diameter, and determine its length at least two inches above the grate; the remaining water from the spring can be led off sideways. If you wish to have more breeding-troughs than one, they should be fixed in the same directions as the first; and a larger pipe must be put to the head of the spring, which must empty itself into smaller pipes laid across the water-trough, so that each trough may have its proper quantity of water conveyed into it; or it may be managed by means of brass cocks; but this is left to the choice of every one's pleasure, as the most convenient method will be soon found out.

(3) After the box or trough is properly finished, it must be placed horizontally upon two legs of wood, stone, or brick; and within upon its bottom put some clean-washed gravel level, about the size of peas and beans, two inches high; afterwards sprinkle some coarser gravel or pebbles over it, the smallest of them of the size of beans, and some bigger than hazel-nuts. This last is done, that upon the surface of the smaller gravel many deep holes may be formed, to prevent the continual motion of the water from carrying away the eggs, it being necessary that they should remain where they were at first sprinkled in.

(4) Then let the water run into the trough as directed in (2), and raise it higher or lower according to the instructions in § I. (4), so that the water covers the gravel always one or two inches. This being done, you have accomplished all that is necessary to the apparatus for breeding trout and salmon.

§ III.

(1) The time of spawning begins the latter end of November, and commonly ends the latter end of January or beginning of February; but the spawning-time of each trout continues only about eight days, as the eggs of the female and sperm of the male become in some sooner, in others later, ripe. Trouts meet in rivulets in great numbers in the before-mentioned months; and such as are ready for spawning pitch upon a place where there is large gravel, and where the water has a quick current; there they push and rub their bellies against the stony bottom, and so violently that they often make great holes; and by means of this motion both male and female get rid of their spawn and sperm.

As a single drop of sperm contains vast numbers of animalcules, sufficient to animate a hundred eggs, and as the water is loaded at this time with the sperm, it is no wonder that almost every egg becomes a fish. Every egg or spawn in the female comes to its perfection and ripeness on the same day; but it is not so with the sperm of the male, for the white roe lies like a solid substance, divided in two parts in its body close to the back, and grows gradually liquid, and dissolves itself into a creamy fluid, beginning at the lower part, and discharges about the sixth part of each division every day; so that within eight days all the sperm becomes liquid and runs off.

§ IV.

(1) *To breed young Trout.*—Take full-sized trouts out of the rivulets in December and January, when they gather together to spawn: as in some rivulets their spawn becomes later ripe, you may, in the latter end of January, let part of the water drain off, by stemming the water above, that you may take as many out as you want. If after gently stroking their bellies with the fingers some spawn or sperm goes off, it is a sign that both are ripe, and those must be put into a large pail or tub for use.

(2) Then take a wooden, earthen, or copper bowl, put into it a pint, quart, or more of clear water; take out of your pail one fish after another, stroke it with the hands or fingers hard downwards, till the spawn discharges into the bowl; you need not fear it will hurt them, for they can, without danger to them, bear great pressing: then rub the belly of the male trout in the same manner, till some of its milt discharges into the water (a little is sufficient), then stir the whole with your hands so as to mix it well, and all the eggs or spawn will be impregnated; then put in more clear water to disperse them more asunder: after the eggs are impregnated with the sperm, they are apt to clog together, which hurts them in the end; it is therefore necessary to thin them with more water, and to sprinkle them into the breeding-trough § I. (4).

A small space will receive a great quantity of spawn, yet they must not lie too thick; otherwise when they touch each other too much, they will get in a few days into putrefaction, and appear as if a fine downy wool was spread over them; and so long as they remain in this state they are unfit. To prevent this, take a thin slice of wood, or a paddle, about the breadth of a hand, and paddle with it backwards and forwards, on the spot where the spawn lies too thick, to spread by this motion the spawn asunder.

(3) It

(3) It will be necessary to repeat this manœuvre twice a week, or at least once a week ; and by paddling with your wooden slice in all parts, you will bring the water upon the eggs in motion ; for let the water be ever so clear, there will adhere to the eggs in a few days a subtil filth, which lays the foundation for their corruption, even when the fish is already alive in the egg ; therefore it is necessary to clear them by this gentle means.

(4) After the eggs have been about three weeks in this state, one may perceive through their hard skin a divided black spot, which are the eyes of the young fish ; the body is too transparent to be seen with the naked eye ; but after four weeks, if you squeeze one of the eggs between your fingers, you will see the fish make a motion, and turn within, then you may perceive his form. At last, after lying five weeks in this state, and under a continual current of running water, the young fishes will bore their heads through the shell of the eggs ; and by moving with their bodies will, in about half an hour, free themselves entirely from the shell, with the yolk of the mother egg hanging to their bellies like a small bag. When they are out of the egg, they will lie still in the cavities between the gravel, and have then the appearances as if the head of a pin were fastened to a reddish field-pea, on account of these hanging bags : for three or four weeks they receive their nourishment from the substance contained in this bag, till by degrees, as the fishes grow larger, the bags disappear ; then they begin gradually to assume the shape of fishes, and having no further sustenance from this bag, they will seek for food themselves. But as in so small a compass as this breeding-trough there cannot be a sufficient quantity of small insects to be found for their sustenance, they seek for room, where they may meet with them in greater abundance ; they then follow the current of the water, and slip through the brass grate at the end of the box, where you should have a larger wooden box like a brewer's cooler, or a small clean fish-pond, covered with gravel to receive them ; in which they will grow in about six months considerably.

§ V.

To instruct my readers as much as possible, I shall add several observations of the formation of these young trouts.

(1) After an egg has been impregnated by the sperm of the male (which is through an invisible opening into it), it lodges in the white liquor under the shell, and round the yolk,

yolk, which last is transparent, tending to a yellowish colour, and seems to fill up the greatest space in the egg, except the little white round it.

(2) As soon as this little animalcule has assumed the nature and form of a fish, it appears that the yolk in the egg is separated by a most extreme thin skin from the outward hard membrane.

(3) The fish itself, except the eyes, is very transparent, and as liquid as a little mucilaginous water, yet in shape longish; it lies bent within the outward membrane of the egg, and round the thin skin that covers the yolk (2).

(4) From this time the fish is to be considered as one body grown to the yolk, from the gills downward to the outlet, which is in length about a quarter part of the inward circumference of the egg. This yolk, which looks like a bag, becomes the belly of the fish; but is extended at first above fifty times the size of its natural belly, and without entrails.

(5) On this expanded belly, especially from the salmon-trout, are plainly to be seen many blood-vessels, divided into smaller branches, and so plain that the arteries may be distinguished from the veins with the naked eye; and it is no wonder, for as it has been mentioned (4), that this hanging belly is fifty times bigger than it should be in proportion to the size of the fish, so the blood-vessels are in proportion expanded, and are to be very plainly seen, as long as the fish remains in a state of transparency like water.

(6) If you open one of these bags with a needle, a liquid runs out of a yellowish colour, which is the nutriment of the fish. Then the bag shrinks in like an empty bladder, and the fish dies. After the fish has been out of its egg about a fortnight, a thin skin separates from the inward coat of this hanging belly, and then it shrinks so much that it disappears entirely. After the belly is entirely shrunk to its proportionable size, this inward skin shrinks likewise; and because the intestines begin from the mouth, it forms a passage into the stomach, and continues narrower contracted and formed into guts, which lay one over another, terminating at the outlet in the belly. It is further to be observed, that the heads of the trouts, when they first have the shape of fishes, have not the usual form; they look as if the snout was chopped off near the eyes; but as their bellies shrink, the heads grow, the mouths are formed, and in about three weeks the heads get their proper shape.

Lastly,

Lastly, I shall make a few additions, which flow from the former observations, and are the result of experiments which I have no inclination to publish at present.

§ VI.

(1) According to the course of nature, no trouts or salmon are generated in ponds or standing waters.

(2) They cannot be bred there if millions of pregnant eggs were put into them.

(3) The young trouts, in the first two or three weeks, are very tenacious of life; for after the head is dead, the body will live two days before they are quite dead: this is to be understood of healthy fish kept in a current of fresh streaming water.

(4) Although the young trouts love to swim with the current, within six weeks, out of their breeding-troughs, § IV. (4), yet they can be kept within them six or more weeks longer by particular manœuvres.

(5) They are not easily to be caught, on account of their small size and nimble motion; notwithstanding they may be collected in a pail.

(6) They may then be put into a proper water, or can be put through a funnel into bottles, and carried to any part, provided the water do not freeze.

(7) The ripe eggs of a trout, after they are four or five days apparently dead, and gone into a kind of putrefaction so that the stench is intolerable, may yet be recovered, and bred into fishes.

(8) The eggs of the trout will not produce fishes so long as they remain connected with the egg stock.

(9) The natural causes why a hen brings a live chicken into the world may very easily be accounted for from the observations I have made in the breeding of trout.

(10) The natural disposition of the animalculæ of the sperm which enters the egg may be considerably increased.

(11) I have made many experiments, in which I have found that two animalculæ had slipt into the egg, and that double fishes have been generated; although they had two bodies, they had but one common stomach: how this happens, see § V. (1).

(12) Of these monstrous productions, the most of them were opposite to one another, and had their stomach in common between them; yet in a strict sense the stomach only, the rest of the guts divided in about three weeks separately.

(13) Some of these double fishes were fixed by their sides

sides together; and this happens when two animalculæ of the sperm enter the egg in a direct line, 90 degrees from one another.

(14) I have seen only one of these double fishes, where the backs were across nearest the tail in a direct angle, so that this fish formed a kind of a cross. This happens when two animalculæ enter one egg, and are placed opposite each other from their direct line to 90 degrees. These monsters (12, 13) were grown together from the head to the opening of the belly, and that (14) had in some degree a joint body; but the backs were distinguished one from another.

(15) All these kinds of monstrous productions die in four or five weeks after their common bag, or belly, is emptied; for as each head endeavours to follow its own direction in pursuit of food, and both hinder each other, neither of them is capable to perform its intention; so it is impossible that either head can receive its proper nourishment, therefore they both must starve.

(16) All monstrous productions in the human and other animal creations, which have a joint stomach, are produced when an egg is impregnated by more than one spermatic animalcula.

(17) All observations made on the trout, and its artificial method of breeding, hold good with regard to salmon.

Signed, S. L. JACOBI.

Directions for Breeding Salmon, Trout, Cray-Fish, &c.

Neither the form nor any particular kind of materials are essential for the troughs; but the following seem to be most eligible: oak of two inches thick, twelve feet long, one foot ten inches wide, and thirteen inches deep on the outside; the top divided into four parts.

Spring-water out of rocks or stony ground is the properest for breeding trouts and salmon; but where it is not to be had, any other spring will do, provided the current is strong enough to prevent its freezing in hard frosty weather. If the spring has not fall enough, you must raise a dam round it, at least a foot higher than the top of your trough; convey the water from thence through a pipe or gutter to the first grate in the opening on the head of the trough of an inch and half diameter, and let the fall from the grate from the end of the pipe or gutter be two or three inches; the remaining water of the spring can be drawn off sideways. If you are inclined to erect several troughs, you may either put them by the side of one another, or at the end,

end, as your quantity of water of the fall admit. Place the troughs horizontally upon legs of wood, stone, or brick; on the bottom of this trough put some clear washed pebbles about the size of peas two inches thick; then sprinkle over them some few larger of the size of small walnuts: this last is done to form recesses, to prevent the continual motion of the water from carrying away the eggs.

Take care that the water which runs in and discharges itself always covers the gravel at least two inches. To breed young trout, you must take some out the latter end of December or the beginning of January, when they meet to spawn: if by stroking their bellies with our fingers some spawn comes out, it is a sign they are ripe, and these fish may be put into a tub for use.

Take a bowl and put a quart of water into it, then take out your fishes one after another, stroke them with your hand or fingers hard downwards, till the spawn discharges into the bowl; you need not fear it will hurt them, for they can without danger bear great pressing: then rub the belly of the male in the same manner, till some of its milt discharges into the water; a little is sufficient; then stir the whole with your hand so as to mix it well, and all the eggs or spawn will be impregnated; then mix more clear water to them to disperse them more asunder, which you must be careful to do, for they are apt to clog together after they are impregnated, and will not hatch if they are thick together; but on the contrary will tend to putrefaction, and get a kind of woolly appearance, which must be remedied by stopping the end where the water runs out till it is an inch or two fuller, and then with a hand or paddle shake violently, which will divide them, and prevent the mud which settles on them from destroying them, and this must be repeated twice a week; but if the spawn is not too thick it need not be done so violently. They will hatch in about five weeks; and in about the same time you may pull out the grate and slider, and let them all out, either in a small bason covered with pebbles through which the stream passes, or into the waters at large. The same rules hold for the salmon; but the sperm and spawn may be procured equally efficacious by cutting open the fish, and taking out the spawn and male sperm.

Small wicker coops must be made with twigs, sufficiently close to prevent the cray-fish from getting out, and put into the troughs with cray-fish in them, when full of spawn; and slices of carrots put in for them to feed on.

XLVI. *On some Phænomena which take place in the Formation of Saltpetre.* By M. LONGCHAMP*.

IN chemistry there are several theories which reason avows, but which experience cannot always confirm. The theory which I am about to give of certain phænomena that take place in the formation of saltpetre, is supported by facts known to every chemist, and confirmed by a great number of experiments, all of which have been published by such respectable authorities, and are in themselves so consonant with our chemical doctrine, that scarcely any objection can be offered against them.

When we reflect on the formation of saltpetre, and on the formation of nitrates in general, we ought to be much surprised at the difficulties experienced in our own and other northern climates in the manufacture of saltpetre; while in other countries, and particularly Spain and India, the nitrate is produced on the surface of the ground, although the inhabitants contribute no manual labour whatever to its formation.

We must seek, therefore, for the cause of this phænomenon in the nature of the climate; and we shall support this assertion by experiments and well-ascertained facts.

In India and Spain when the rainy season is at an end the atmosphere becomes dry, and continues so during a great part of the year; while in the North it is always humid, except when the cold is so severe as to precipitate part of the water which it holds in solution. But as the dryness of the southern hemisphere has a different origin from that of the northern, the phænomena are also very different. In fact, the atmosphere being very warm seeks every where for water to dissolve, and sucks it, as it were, from the bowels of the earth; but this water coming to the surface of the soil, brings with it the nitre which it held in solution, and deposits it to be combined with the air. In the North, on the contrary, not only is the air cold, but the ground also: there is no evaporation, and the water remains in its bowels; and when, in summer, the dryness occasioned by the heat tends to bring the water to the surface of the earth, and brings the nitre which it held in solution, fresh rains succeed and carry it down again to a certain depth.

In this way we can easily explain why the nitre which we find in the earths of India and Spain presents itself at

* From *Journal de Physique*, August 1809.

the surface of the ground, while in our own climate we cannot collect it, if it exists there at all times.

But it may be asked, Does nitre exist in our soil? This cannot be doubted for a moment, since we extract it from several plants, such as lettuce, onions, turnips, &c., particularly turnsole. Now it has been clearly established that it is not formed by the act of vegetation, but rather that it existed ready formed in the soils in which these plants have been cultivated*.

It remains therefore to explain how the nitre is formed in the bowels of the earth. Is it to the decomposition of animal and vegetable substances that the formation of nitrates is owing? Without doubt nitric acid is formed in this decomposition, and consequently nitrates, since there are salifiable bases for saturating this acid: but I do not think that this is the principal cause of the formation of the nitre; for, in fact, we know extremely well that the nitric acid in artificial saltpetre works is produced very slowly, and cannot be formed except in a humid and stagnant atmosphere, at a temperature always uniform and rather low. Now not one of these conditions is fulfilled either in Spain or the East Indies. We cannot therefore attribute to the decomposition of animal and vegetable substances the formation of nitre in the bowels of the earth; or at least it is but a very trifling cause compared to the effects.

Does nitre exist ready formed in the bowels of the earth, as we find the sulphates, carbonates, boratés, muriate of soda, &c.? This has not been hitherto proved by any one fact †; and even if it be found in mines, does it follow that this salt must be diffused over the whole surface of the globe? Sea salt, however, which is so abundant in nature, is not to be seen efflorescing on the high roads in Spain.

Nitre not being the result of the decomposition of animal and vegetable substances, nor being a natural production, we ought to seek its origin in the atmosphere; and this will be very easy to find.

The rains which fall in the Indies and Spain are fre-

* *Recueil de Mémoires sur la Salpêtre*, published by the *Académie des Sciences*.

† A letter from M. Dolomieu in the Memoirs above quoted, speaks of a mine of saltpetre found at Latera in the kingdom of Naples. This mine, according to the report made to him, was so considerable, that one cavity alone contained more than 50,000 quintals of pure saltpetre; and as it contained a great number of these cavities, it may be regarded as inexhaustible. This fact, not having been recorded in other works, particularly in those of Fourcroy and Haüy, I presume must have been very inaccurate.

quently

quently preceded and accompanied by loud explosions occasioned by thunder; while those which fall in the northern regions do not present the same phænomenon. But we know very well that thunder is caused by the approximation of clouds, some of them being affected with positive or vitreous electricity, and others with negative or resinous electricity*. Now we also know that when we pass a certain quantity of electrical sparks through a mixture of azotic and oxygen gas, nitric acid is formed: therefore when the same phænomenon takes place in the air and in our laboratories, the same results ought to take place; and this is what actually happens: for it has been clearly proved by Margraf, and subsequently by several other chemists, that all rain water contains nitric acid. The stronger the detonation, the greater quantity of this acid is formed: in Spain and India, therefore, where the thunder is more frequent in rainy weather, and where the detonations are also stronger than in northern regions, of course more nitric acid is produced in the former than in the latter regions.

By this formation of nitric acid in the air, may we not explain a part of the phænomena which we observe in storms? I shall examine therefore the theory which some naturalists have given on the subject. M. de Saussure thinks that the electric fluid exists in the higher regions; that it every where tends to find an equilibrium; and that our globe, being frequently deprived of it by some given causes of destruction, recovers it in the higher regions, where the rarefaction of the air admits of its existing more easily than in our atmosphere. From this he conceives a part of the earth to be sufficiently heated to reduce into vapour a part of the water on its surface: this vapour, communicating caloric to the air which surrounds it, renders it thinner and forces it to ascend. In this way there is a vertical wind established which carries the heat into the upper strata of the air, and renders them susceptible of dissolving the vapours which it carries along with it. The air being in no respect cold enough for condensing them, they are diffused nearly uniformly into the mass of a very high vertical column. But the small inequalities which exist in this mass, and the agitation given to the air by the vertical wind which carries it along with it, diminishes the transparency of the column, which thereby becomes susceptible of being more strongly heated by the rays of the sun; this

* I have indiscriminately used the expressions *vitreous* or *positive*, because both hypotheses explain equally well these kinds of phænomena.

heat rendering the mass lighter, forces it to rise higher and higher, and to attain the regions where the rarefaction of the air gives to the electric fluid the liberty of moving up and down in the column:

If M. Saussure succeeds by this reasoning in accounting for the loud detonations which we then hear, it does not appear to me that it explains the causes of the formation of water, or of the other aqueous substances which are precipitated. May we not be allowed to suppose that the positive or vitreous fluid and the negative or resinous fluid, being brought into contact by means of the column of vapours, effect the formation of the nitric acid; and that the water held in solution by the azotic and oxygen gas, being set free by their combination, occasions the phænomena which we observe in these circumstances?

But if this formation of the nitric acid in the air were doubtful, I could support it by a phænomenon generally known, but which has not yet received a satisfactory explanation; whereas, according to my theory, it is a fact perfectly natural, and which, I must also add, has even served as the basis of all my reasoning.

We cannot conceive how the nitrate of potash comes to be formed under the tiles of a roof, since this fact is in contradiction with every thing that we know on the subject of the nitrates; for, as I have said, the nitric acid is only formed, in our climate, in places where the air is stagnant, and even when this temperature does not generally exceed that of our globe*. Now in a granary the air is not stagnant, and is never at the same temperature, since it varies annually from -10° to $+20^{\circ}$ ($= +18^{\circ}$ to 68° of Fahr.): we must therefore seek for the cause of this phænomenon in other principles than those adopted by the chemists to account for the formation of saltpetre.

Having reflected on the long continuance of snow on the roofs of houses, and knowing also that this substance contains a considerable quantity of nitric acid, I cannot help thinking that this is the sole cause of the phænomenon. In short, the tiles under the above circumstances perform the same office with the earths of India and Spain: the part which is inside the granary, being always dry, absorbs the nitrated water found in its interior; and this water, being dissolved by the ambient air, deposits the nitre on the surface of this tile, as it deposits it on the surface of the soil of warm countries. Thus in winter it is the nitric acid of

* *Recueil de Mémoires sur le Salpêtre.*

the snow which is combined with the salifiable bases of the tile: in summer the former is brought by the rains.

If it be easy, from the above theory, to explain how the nitric acid comes to be found in the earth of India and Spain, as well as in the tiles of the roof, it gives us no assistance in explaining why nitrate of potash is found there in preference to nitrates of lime and of alumine, since tiles are made of these salifiable bases; and without doubt they help to form the soils of Spain and India, while no potash at all enters into their composition. My object was to point out the origin of the nitric acid in most saltpetre substances, and not that of potash: I shall merely add, for the sake of those who ask reasons for every thing because they wish to account for every thing, that it is a fact of observation, namely, that the same materials which are applied to the formation of nitrates, when exposed to a damp and stagnant air, yield nothing for the most part but nitrate of lime; whereas, when they are exposed to a dry and agitated air, they yield almost nothing but nitrate of potash*.

It is not enough to establish a theory, we must also render it as useful as possible; and for this reason I have published this paper.

The most direct application that can be made of these hints is without doubt the manufacture of saltpetre. In fact, there are about three millions of pounds of saltpetre made annually; and for this it requires at least 798 millions of saltpetre materials, since I estimate about six ounces as being the produce of each cwt. of materials. At least an equal quantity of water is used in lixiviating these materials; and if we admit that there is only 0.0001 of nitric acid in this water, it follows that it would give as the result 79,800 pounds of acid; which, adopting the proportions given by Berthollet for the component parts of nitrate of potash, would give 164,130 pounds of this salt.

Rain and snow water may therefore be advantageously employed, not only in lixiviating saltpetre substances, but for watering artificial nitre-works, and by this means the produce will be greatly increased.

* *Recueil de Mémoires sur le Salpêtre.*

XLVII. *New analytical Researches on the Nature of certain Bodies, being an Appendix to the Bakerian Lecture for 1808. By HUMPHRY DAVY, Esq. Sec. R. S., Prof. Chem. R. I.**

1. *Further Inquiries on the Action of Potassium on Ammonia, and on the Analysis of Ammonia†.*

THE most remarkable circumstances occurring in the action of potassium upon ammonia are the disappearance of a certain quantity of nitrogen, and the conversion of a part of the potassium into potash.

The first query which I advanced in the last Bakerian Lecture, on this obscure and difficult subject, was whether the gas developed in the first part of the process of the absorption of ammonia by potassium is hydrogen, or a new species of inflammable æriform substance, the basis of nitrogen?

Experiments made to determine this point have proved, as I expected, that the gas differs in no respect from that given out during the solution of zinc in sulphuric acid; or that produced during the action of potassium on water. By slow combustion with oxygen, it generates pure water only, and its weight, in a case in which it was mixed with atmospherical air, precisely corresponded with that of an equal quantity of hydrogen.

Another query which I put is, Has nitrogen a metallic basis which alloys with the metals employed in the experiment?

This query I cannot answer in so distinct a manner; but such results as I have been able to obtain are negative.

I have examined the potassium generated in the process. It has precisely the same properties as potassium produced in the common experiment of the gun-barrel; and gives the same results by combustion in oxygen, and by the action of water.

In cases in which I had distilled the olive-coloured fusible substance in an iron tray, the surface of the tray appeared much corroded, the metal was brittle, and appeared

* From Philosophical Transactions for 1809, Part II.

† The account of the principal facts respecting the action of potassium on ammonia, in this communication, were read before the Royal Society, February 2, 1809. The paper was ordered to be printed March 16, 1809. At that time, having stated to the council that I had since made some new experiments on this matter, and on the subjects discussed in the Bakerian Lecture for 1808, I received permission to add them to the detail of the former observations for publication.

crystallized. I made a solution of it in muriatic acid; but hydrogen alone was evolved.

I distilled a quantity of the fusible substance from nine grains of potassium in an iron vessel, which communicated with a receiver containing about 100 grains of mercury, and by a narrow glass tube the gas generated was made to pass through the mercury; the object of this process was to detect if any of the same substance as that existing in the amalgam from ammonia was formed; but during the whole period of distillation the mercury remained unaltered in its appearance, and did not effervesce in the slightest degree when thrown into water.

That the nitrogen which disappears in this experiment is absolutely converted into oxygen and hydrogen, and that its elements are capable of being furnished from water, is a conclusion of such importance, and so unsupported by the general order of chemical facts, that it ought not to be admitted, except upon the most rigid and evident experimental proofs.

I have repeated the experiment of the absorption of ammonia by potassium in trays of platina or iron, and its distillation in tubes of iron, more than twenty times, and often in the presence of some of the most distinguished chemists in this country, from whose acuteness of observation I hoped no source of error could escape.

The results, though not perfectly uniform, have all been of the same kind as those described in page 55*. Six grains of potassium, the quantity constantly used, always caused the disappearance of from 10 to 12.5 cubical inches of well dried ammonia. From 5.5 to 6 cubical inches of hydrogen were produced, a quantity always inferior to that evolved by the action of an equal portion of the metal upon water. In the distillation from 11 to 17 cubical inches of elastic fluid were evolved, and from 1.5 to 2.5 grains of potassium regenerated.

The quantity of ammonia in the products, varied from a portion that was scarcely perceptible to one-twelfth or one-thirteenth of the whole volume of elastic fluid; and it was least in those cases in which the absence of moisture was most perfectly guarded against. Under these circumstances likewise, more potassium was revived; and the unabsorbable elastic fluid, and particularly the hydrogen, in smaller proportion.

When the products of distillation were collected at different periods, it was uniformly found that the proportion

* Page 9 of our present volume.

of nitrogen to the hydrogen diminished as the process advanced.

The first portions contained considerably more nitrogen in proportion, than the gases evolved during the electrization of ammonia, and the last portions less.

I shall give the results of an experiment, in which the gases produced in distillation were collected in four different vessels, and in which every precaution was taken to avoid sources of inaccuracy.

The barometer was at 29.8, thermometer 65° Fahrenheit.

Six grains of potassium absorbed 12 cubic inches of well dried ammonia. The metal was heated in a tray of platina, and the gas contained in a retort of plate glass.

5.8 cubical inches of hydrogen were produced.

The fusible substance was distilled in an iron tube of the capacity of 3 cubical inches and half filled with hydrogen, the adaptors connected with the mercurial apparatus contained .8 of common air.

The first portion of gas collected (the heat being very slowly raised, and long before it had rendered the vessel red,) equalled 7.5 cubical inches. It contained .6 of ammonia. 7 of the residuum, detonated with $4\frac{1}{2}$ of oxygen gas, left a residuum of 4.

The second portion, equal to 3 cubical inches, contained no ammonia. 7.2 measures of it, detonated with 3.8 of oxygen, left a residuum of 3.5.

The third portion was equal to 5 cubical inches; at this time the tube was white hot; it contained no ammonia; 8.5 of it detonated, with 4.5 of oxygen, diminished to 2.5.

The last portion was a cubical inch and half, collected when the heat was most intense. 4.5 measures, with 3.75 of oxygen, left a residuum of 2.8.

The iron tube contained, after the experiment, (as was ascertained by admitting hydrogen when it was cool,) 2.7 of gas; which seemed of the same composition as the last portion. The adaptors must have contained .8 of a similar gas.

The tube contained potash in its lowest part, and in its upper part potassium, which gave by its action upon water $1\frac{1}{2}$ cubical inch of hydrogen.

As the largest quantity of hydrogen is always produced at that period of the process in which the potassium must be conceived to be regenerated, and in which the gases being in the nascent state, its power of action upon them would be greatest, it occurred to me, that if nitrogen was decomposed in the operation, there would probably be a

larger quantity of it destroyed by the distillation of the fusible substance, with a fresh quantity of potassium, than by the distillation of it in its common state. On this idea I made several experiments: the results did not differ much from each other, and were such as I had expected. I shall describe one process made with the same apparatus as that which I have just detailed.—Barometer was at 29.5, thermometer 70° Fahrenheit.

Six grains of potassium were employed in an iron tray; 10 cubical inches of ammonia were absorbed, a small globe of metal remained unconverted into the fusible substance. A fresh piece of potassium, weighing six grains, was introduced into the tray.

The iron tube and the adaptors (having together a capacity equal to 4.3 cubical inches) contained common air.

The gas was collected in three portions, there was no absorbable quantity of ammonia in either of them.

The first portion, that produced before the tube became red, was eight cubical inches. 10.25 of it, detonated with 3.5 of oxygen, diminished to 8.

The second portion equalled five cubical inches; 9½ of this, with 5 of oxygen, left a residuum of 3¼.

Of the third portion, 2 cubical inches and ¼ came over. 9 of it, detonated with 5 of oxygen gas, left a residuum of 1.4.

The iron tube and the adaptors contained, at the end of the experiment, as was proved by cooling and the admission of hydrogen, 2.3 cubical inches of gas, which appeared of the same composition as the third portion. Nearly 7 grains of potassium were recovered.

A comparison of these results, with those stated in the preceding page, will fully prove, that there is a much smaller proportion of nitrogen to the hydrogen, in the case in which the olive-coloured substance is distilled with potassium, than in the other case, and there is likewise a larger quantity of potassium converted into potash.

The loss of nitrogen, and the addition of oxygen to the potassium, are sufficiently distinct in both processes; and the want of a correspondence between these results, and those of the experiment detailed in page 55*, are not greater than might be expected, when all the circumstances of the operation are considered. In the instance in which a double quantity of potassium was employed, more potash must have been formed from the oxygen of the common air in the tubes; and the fusible substance, in passing

* See page 9 of this volume.

through the atmosphere, absorbs in different cases different quantities of oxygen and of moisture: during the intervals of the removal of the different portions of gas, likewise, some globules are lost.

In instances when the heat has been more rapidly raised, I have generally found more potassium destroyed, and less nitrogen in proportion in the aëriform products. In such cases, likewise, the loss of weight has been much greater; the gases have been always clouded, and the adaptors, after being exposed to a moist air, emitted a smell of ammonia; from which it seems likely that small quantities of the dark gray substance described in page 50 of this volume* are sometimes carried over undecomposed in the operation.

In some late experiments, I substituted for the iron tube, a tube of copper, which had been bored from a solid piece, and the sides of which were nearly a quarter of an inch in thickness. My object in using this tube was not only to prevent the heat from being too rapidly communicated to the fusible substance, but likewise to be secure that no metallic oxide was present; for though the iron tubes had been carefully cleaned, yet still it was possible that some oxide, which could not be separated from the welded parts, might exist, which of course would occasion the disappearance of a certain quantity of potassium.

I shall give the results of one of the processes, which I regard as most correct, made in the tube of copper. The barometer was at 30.5; thermometer was at 59° Fahrenheit.

The tube contained two cubical inches and half, and was filled with hydrogen.

Six grains of potassium, which had absorbed 13 cubical inches of ammonia in a copper tray, were employed.

The adaptors connected with the mercurial apparatus and the stop-cocks, contained .7 of atmospherical air.

The gas given off was collected in two portions.

The first portion was equal to 11 cubical inches. It contained .8 of ammonia; 11 of the residuum, detonated with 8 of oxygen, left 8.

The second portion equalled 2 cubical inches. They contained no ammonia. 10 of this gas, with 8 of oxygen detonated, left a residuum of 10.

There remained in the tube and adaptors 1.1 cubical inch of gas.

The quantity of hydrogen produced by the action of the potassium, which had been regenerated, equalled 4.5 cubical inches.

* Phil. Mag. vol. xxxiii. page 487.

In this experiment the heat was applied much more slowly than in any of those in which the iron tube was used, and even at the end of the operation the temperature was little more than that of cherry red.

In the upper part of the stop-cock there was found a minute quantity of gray powder, which gave ammonia by the operation of moisture.

In no case, in which I have used the copper tube in like processes of slow distillation, has there been less than four grains of potassium revived; and the proportion of nitrogen to the hydrogen in the gas evolved has been uniformly much greater than in processes of rapid distillation in the tubes of iron; but the whole quantity of elastic matter procured considerably less.

Copper has a much stronger affinity for potassium* than iron. It occurred to me as probable, that this attraction, by preventing the potassium from rising in vapour at its usual temperature, and likewise by the general tendency of such combination to give greater density, might occasion a diminution of its action upon the nitrogen in the nascent state. Ammonia has a strong attraction for the oxide of copper, and it consequently is not unlikely that the fusible substance may combine with metallic copper, and that this compound may not be entirely destroyed in the distillation. And assuming this, it may be conceived that the loss of hydrogen partly depends upon some combination of the basis of ammonia with copper.

I had a tube, of the capacity of $2\frac{1}{4}$ cubical inches, made of wrought platina, cemented by means of fine gold solder. The fusible substance was obtained (as usual from six grains of potassium) in a tray of platina, where it was brought in contact with a large surface of platina wire; the distillation was slowly conducted; but before the temperature of the tube had approached to that of ignition, it dissolved and gave way at the points where it was soldered, and a violent combustion took place. Only seven cubical inches of gas were collected; but of this, allowing for the hydrogen that filled the tube, nearly three-fifths were nitrogen.

I am making preparations for performing the experiment in a bored tube made from a single piece of platina, and likewise in tubes made of other metals, and I hope to be

* Copper heated in potassium speedily dissolves, and diminishes its fusibility; but potassium requires a white heat to enable it to combine with iron. In another experiment, in which I distilled the fusible substance in an iron tray, contained in the copper tube, a considerable quantity of copper, that had been dissolved, was found in the state of powder deposited upon the tray, or loose in the bottom of the tube.

able, in a short time, to have the honour of laying the results before the society.

I shall make no apology for bringing forward the investigation in its present imperfect state, except by stating that my motive for so doing, is the desire of being assisted or corrected by the opinions and advice of the learned chemical philosophers belonging to this illustrious body. In an investigation connected with almost all the theoretical arrangements of chemistry, and in operations of so much delicacy, it will, I conceive, be allowed, that it is scarcely possible to proceed with too much caution, or to multiply facts to too great an extent.

The different phænomena presented by the processes of distillation in different metallic tubes, may lead to new explanations of this intricate subject; and though the facts cannot be easily accounted for, except on the supposition that nitrogen is an oxide, yet till the proportions and weights are distinctly ascertained, the inquiry cannot be considered as far advanced; for in an experiment in which the processes are so complicated and delicate, and in which the data are so numerous, it is not easy to be satisfied that every source of error has been avoided, and that every circumstance has been examined and reasoned upon.

All conclusions on the action of potassium on ammonia, are immediately dependent upon the results of the electrical analysis of the volatile alkali. In a letter which I received in the course of the last month from Dr. Henry, that excellent chemist has stated that he conceives I have rather under-rated the quantity of nitrogen in ammonia, according to the proportions given in the Bakerian Lecture for 1807. This notice has induced me to repeat the experiment, under new circumstances, and I find not the slightest reason for doubting of the entire accuracy of my former results.

In the new trial, I used mercury which had been recently boiled in the tube for electrization; the ammonia was introduced after being long dried by caustic potash, from a receiver in which it had not been generated, and which had likewise been inverted over boiling mercury. The gas left no perceptible residuum, when absorbed by water deprived of air by boiling. In this process, 15 measures of ammonia expanded, so as to fill 27 measures; and the hydrogen by detonation with oxygen, over water freed as much as possible from air, proved to be to the nitrogen as 73·8 to 26·2. In the experiment three explosions were made, the oxygen being deficient in the first two; so that no ni-
trogen

nitrogen could have been condensed in the form of nitric acid.

Except when precautions of this kind are employed, as I have before noticed, no accurate data can be obtained respecting the proportions of permanent gases obtained from ammonia by electricity.

When the gas is generated and decomposed over the same mercury, there is always a greater expansion than the true one; and when the mercury is not boiled in the tube, and when common water is used, the nitrogen will be always over-rated, unless this error is counteracted by an opposite error, that of detonating with an excess of oxygen*.

Dr. Henry had the kindness to send me the apparatus, in which he conceived, at that time, that he had witnessed the formation of water in the decomposition of ammonia by electricity, by his ingenious method of applying hygrometrical tests.

I tried one experiment only with it, and in this there seemed to me to be more moisture exhibited in the elastic matter after electrization than before, when it was cooled by the evaporation of ether: but on maturely considering this question, I do not think that the appearance of moisture even offers a decided proof of the existence of loosely combined oxygen in ammonia. To common hygrometrical tests, water must be less sensible in ammonia than in hydrogen or nitrogen, from its tendency to be precipitated in the form of alkaline solution, and likewise probably from its having a stronger adherence to the gas; and the elastic fluid generated, from the increase of volume will be capable of containing more aqueous vapour.

It is not easy to determine, with perfect precision, the specific gravity of a gas, so light as hydrogen and even ammonia; but the loss of weight, which appears to take place in the electrical analysis of ammonia, cannot, I think, with propriety, be referred entirely to this circumstance: whether the solution that I have ventured to give † be the true one, I shall not, in the present state of the inquiry, attempt to discuss.

The question of ammonia being analogous to other sali-

* It will be seen by Dr. Henry's letter, [page 369 of our present Number, EDIT.] that in repeating his processes, since this paper was written, he has gained results almost precisely the same as those indicated in the text; and there is every reason to believe, that 100 of ammonia in volume uniformly become 180, when decomposed by electricity, and that the gas produced consists in 100 parts of 74 hydrogen and 26 nitrogen.

† Bakerian Lecture, 1807, p. 40.

ñable bases in its constitution, is determined by the phænomena presented by the amalgam from that alkali; and if the conversion of nitrogen into oxygen and hydrogen should be established, it would appear that both hydrogen and nitrogen must be different combinations of ammonium with oxygen, or with water.

[To be continued.]

XLVIII. *Inquiry whether Nævia Materna, with which Children are sometimes born, should be attributed to the Imagination of the Mother.*

To Mr. Tilloch.

SIR, **I**N looking over a late volume of the Linnean Transactions, I met with a fact that seems almost to set at rest a long disputed physiological question, which formerly engaged a considerable share of attention in the philosophical world, but has not hitherto, as far as I know, been satisfactorily resolved.

The question to which I allude, is that which refers to the share which is to be attributed to the imagination of the mother in producing the *marks* which infants are sometimes born with. By philosophers of a former day, the affirmation of this question was decidedly insisted upon, and more than one volume has been filled with reputed instances of the effects of the mother's imagination upon her offspring. In the present day, too, the whole female world still retain a similar belief upon this subject, and almost every woman can quote her own or her neighbour's experience in support of her opinion. The medical men, however, always laugh at their histories, and consider them as mere idle tales. I was myself for a long time prepossessed with the same notion; but at length I heard of two or three instances of children having been born without limbs or with wounds, in consequence of the mother's imagination having been violently acted upon; which almost staggered my scepticism. One of these cases was related to me by an intelligent friend who had seen the child born with only one leg, as well as its mother, who declared her firm belief, that the cause of this imperfection in her child was a violent fright which she experienced from seeing a beggar suddenly uncover the wounded stump of his thigh. My friend very closely cross-questioned this woman; and the result of his examination was an entire conviction that it

was

was a fact that she had been frightened when pregnant in the way she stated, and that the infant subsequently born was maimed precisely as the beggar was who had been the cause of her alarm. Since learning this fact I have been more inclined to listen with patience to similar histories, yet with some doubts, chiefly built upon the universal incredulity of the medical men to whom I have related them, remaining. These, however, are now done away by the fact stated in the Linnean Transactions alluded to above, the substance of which I shall briefly state.

The servant of Mr. Milne, F.L.S., in removing a kettle from the fire, trod very heavily upon the tail of a pregnant she cat lying upon the hearth. The cat immediately uttered a dreadful scream, and ran out of the room with every mark of violent terror. When this cat littered, half of her kittens had their tails bent in the middle at right angles, with a round knot thicker than the rest of the tail at the angle formed.

This fact seems to be very important, and to prove nearly to a demonstration, that the imagination of pregnant females has the power of acting upon the bodily conformation of their young. It is very certain that the tails of the young kittens were not trodden upon. What then could have thus distorted them, but the imagination of the parent influenced by the sudden alarm which she felt? It may be denied that the distortion was the consequence of the pressure on the mother's tail; but such a denial appears to me very unphilosophical, especially when we take into account the number of similar facts on record, with respect to the human species. If this were the first instance heard of, there would doubtless be reason for hesitation; but it is so closely analogous to hundreds of like events which are stated to have occurred to women, that it seems to me conclusive. It may be said perhaps that cats are exposed to have their tails trodden upon every day, and that we never hear of similar mutilations. But it should be considered, that in the case recorded in the Linnean Transactions, it was the *extraordinary* injury sustained by the animal, and the *violence* of the impression it made upon her, that alone caused the circumstance to be recollected. Mr. Milne would never have remembered any ordinary scream of his cat from having been accidentally trodden upon, nor have thought of referring to it the remarkable conformation of her kittens.

I shall be glad if some of your physiological correspondents would favour me with their opinion on this statement.

ment. The importance of the subject cannot be doubted, and it appears to me to have been very undeservedly neglected of late.

I am, sir, your obedient servant,

Nov. 17, 1809.

ENCEPS.

XLIX. *On Crystallography.* By M. HAUV. Translated from the last Paris Edition of his *Traité de Minéralogie*.

[Continued from p. 302.]

Of secondary Forms, the Molecules of which differ from the Parallelepipedon.

IT is a character common to all the primitive forms to be divisible parallel to their different faces. In the parallelepipedon, this division, when not joined to any other which can take place in different directions, evidently leads to a form of molecule similar to the nucleus. In the regular hexahedral prism, it gives as a molecule an equilateral triangular prism, as we have already seen in another place. In the octahedron, it seems to tend towards molecules of two different forms, some tetrahedrons and others octahedrons. This mixed kind of structure takes place also with respect to the tetrahedron. But every probable reason concurs to exclude the octahedron, and to adopt the tetrahedron in preference, as being, in these cases, the true integral molecule. Under the head *Fluited Lime* more particulars will be found on this subject.

If we divide in the same way the dodecahedron with rhombic planes, the molecules will be, without equivocation, tetrahedrons with triangular isoscele faces. Under the article *Garnet*, every thing relative to this kind of structure will be found.

With respect to the dodecahedron with isoscele triangular planes, we cannot extract the molecules that compose it without dividing it in directions different from those which would be parallel to the faces. The tranchant planes in this case ought to pass by the axis, and by the ridges contiguous to the summits, whence irregular tetrahedrons result as molecules. This point of theory will be treated of in the article *Quartz*.

The other primitive forms are also sometimes subdivided in directions which are not parallel to their faces. We have already had an example of this, relative to the rhomboid of the tourmaline, whose subdivision, following planes which

which pass by the axis and by the oblique diagonals, gives the result represented in fig. 10, where we see that the molecules are tetrahedrons. Observation also proves that the oblique quadrangular prism which is the nucleus of pyroxene, has natural joints situated parallel to a plane which would pass by the small diagonals of its bases; from this we may conclude that its molecules are triangular prisms.

I shall not insist further on these modes of division, which will be explained at greater length when we come to speak of the articles which represent them; but I ought not to pass over a result which serves to connect the crystallization of substances, whose molecule is the tetrahedron or triangular prism, with that of substances which have, as primitive forms, simple assemblages of elementary parallelipedons.

This connection consists in the tetrahedral or prismatic molecules being always assorted in such a manner, in the interior of the primitive form and of secondary crystals, that on taking them by small groups of twos, fours, sixes, or eights, they compose parallelipedons, so that the ranges subtracted by the effect of decrements are nothing else than sums of these parallelipedons.

That we may better conceive how this takes place, let us conceive for a moment that the small rhomboids which represent the molecules of carbonated lime are divisible into tetrahedrons, as we have seen with respect to the rhomboids which belong to the tourmaline. This view does not change the explanations which we have given of the different secondary forms of which carbonated lime is susceptible: *i. e.* in order to determine these forms by the help of theory, we should always confine ourselves to the consideration of decrements by one or more ranges of rhomboidal molecules.

What is only an hypothesis with regard to carbonated lime, is changed into reality with the tourmaline. Although the rhomboids produced at first by the mechanical division of the crystals of this substance are ultimately resolved into tetrahedrons, the decrements which give the secondary forms are produced by subtractions of these rhomboids similar to the primitive form; so that we may suppose, in calculations relative to the determination of these forms, that the tetrahedrons which represent the true molecules are connected with each other in an invariable manner in each rhomboid.

Let us cite another example drawn from a very simple structure,

structure, which is that of crystals whose primitive form is the regular hexahedral prism. Let AD be always (fig. 40) one of the bases of this prism subdivided into small triangles which are the bases of so many molecules. It is evident that any two given triangles adjoining the other, such as Api , AOi , compose a rhombus, and consequently the two prisms to which they belong form by their union a prism with rhomboidal bases, which is one of the kinds of parallelopipedon.

Let us now imagine that the triangular prisms, which are the elements of these parallelopipedons, are invariably connected with each other. We may substitute for the arrangement represented in fig. 40, that of fig. 41 merely composed of rhombuses, which will be the bases of so many parallelopipedons.

Now if we suppose a series of laminae piled up on the hexagon $ABCDFG$, and which undergo, for example, on their different edges, subtractions of one range of parallelopipedons similar to those now in question, these edges will be successively arranged like the sides of hexagons $ilmnrk$, $kuxyge$, &c.: hence we see that the quantity in which each lamina shall exceed the following one will be a sum of parallelopipedons, or prisms with rhomboidal bases; and it is easy to judge that the result of the decrement, supposing that the latter attains its limit, will be a straight hexahedral pyramid, which will have as a base the hexagon $ABCDFG$.

All the other different primitive forms of the parallelopipedon give analogous results. We might even substitute for each of these forms a nucleus similar to the small parallelopipedon, which are assemblages of tetrahedrons or triangular prisms; and we should also succeed in explaining the secondary forms by laws of decrement referred to this nucleus, which would also be given by mechanical division. We shall use it in this manner with respect to quartz, because in this case the substitution of the parallelopipedon for the bipyramidal dodecahedron leads to more simple decrements for certain varieties*.

I shall

* We are acquainted with crystals whose mechanical division gives first a prism with rhomboidal bases which have different angles of 120° and 60° . This prism may be afterwards subdivided in the direction of one of the diagonals of its bases: from which it results that we might also extract immediately from the secondary crystal a hexahedral prism; but which would not be regular. In these cases we shall adopt the prism with rhomboidal bases for the nucleus, because this form, besides being simpler, has a character of regularity

I shall give the name of *subtractive molecules* to those parallelipedons composed of tetrahedrons, or of triangular prisms, and whose ranges measure the quantity of the decrement which the laminæ of superposition undergo when applied on the faces of the primitive form.

We find from what precedes, that, to speak precisely, theory would not admit of our proceeding towards its principal object, on stopping at the parallelipedons given in the first place by the mechanical division of crystals; and the kind of anatomical dissection afterwards undergone by these parallelipedons, when we try to ascend to the true form of the integral molecule, is an ulterior step, without which, observation, rather than theory, would leave something unfinished. The parallelipedon here represents unity, at which all the results of the theory end; and fractions formed of its subdivisions beyond this unity are of no consequence.

We see at the same time, that by means of this conformity between the results given by the various forms of integral molecules, theory has the advantage of generalizing its object by chaining to a single fact the multitude of facts, which from their diversity seem little susceptible of concurring in one common point.

regularity which the other has not, and which consists in the equality and similitude of its lateral faces.

Here a consideration presents itself which we ought not to omit. Let $ABCD$ (fig. 42) be the upper base of one of the prisms we have mentioned. Let us suppose for a moment that this prism cannot be subdivided except parallel to its four panes and to its two bases. The arrangement of the small rhombuses situated on both sides of the rhombus $ABCD$ will represent the effect of a decrement by one range on the two longitudinal ridges terminated by the points A and C ; and it is visible that this decrement will produce for the secondary form, a hexahedral prism, whose base is represented by $B'l m D' r h$.

Now if we conceive that the rhomboidal prism which has for its base $ABCD$, may be subdivided in the direction of the diagonal BD into two triangular prisms, all the small rhomboidal prisms of which it is the assemblage being susceptible of the same division, we shall suppose that the small vacuums which existed between l and m on one hand, and between h and r on the other, in the hypothesis of the decrement, are filled up by triangular prisms, in which case the hexahedral prism will be immediately given without any decrement. Nevertheless we cannot admit of considering the faces which will be in this case as being produced in virtue of a decrement by one range, because then the form of the secondary crystal is merely composed of small rhomboidal prisms similar to the primitive form, as would have taken place if the decrement was produced by two or more ranges; so that here it is only a particular case which should seem to have been assimilated with all the others for the sake of uniformity in the laws of structure. The same reasoning applies to primitive forms different from the parallelipedon, as we shall find in the course of this work.

Difference

Difference between the Structure and the Increment.

In the preceding development of the theory, we have supposed that the component laminæ of crystals originally of one and the same species, issue from one common nucleus, undergoing decrements subjected to certain laws, upon which the forms of these crystals depended. But here it is only a conception, adopted to make us more easily perceive the mutual connections of the form in question. Properly speaking, a crystal in its entire state is only a regular group of similar molecules. It does not commence by a nucleus of a size proportioned to the volume which it ought to acquire, or, what comes to the same thing, by a nucleus equal to that which we extract by the aid of mechanical division; and the laminæ which cover this nucleus are not applied successively over each other in the same order in which the theory regards them. The proof of this is, that among crystals of different dimensions which are frequently attached to the same support, those which can only be distinguished by the microscope are as complete as the most bulky; from which it follows that they have the same structure, *i. e.* they already contain a small nucleus proportioned to their diameter, and enveloped by the number of decreasing laminæ necessary, in order that the polyhedron should be provided with all its faces. We do not perceive these various transitions of the primitive to the secondary forms, which ought to take place if crystallization constructed, as if by courses, the species of pyramids superadded to the nucleus, in going from the base to the summit*.

We must therefore conceive, for example, that from the first instant a crystal, similar to the dodecahedron with rhomboidal planes derived from the cube (figs. 11 and 12), is already a very small dodecahedron, which contains a cubical nucleus proportionally small, and that in the following instants this kind of embryo increases without changing its form, by new strata which envelop it on all sides; so that the nucleus increases on its part, always preserving the same relation with the entire crystal.

We shall make this idea apparent by a construction relative to the dodecahedron now mentioned, and represented by means of a plane figure. What we shall say of this figure may easily be applied to a solid, since we may al-

* This, however, is only generally true; for it sometimes happens, in artificial crystallization, (and it is very probable that we may say as much of that of natural bodies,) that a form which had attained a certain degree of increment suddenly undergoes variations by the effect of some particular circumstance.

ways conceive a plain figure like a section made in a solid. Let $t s z s'$, therefore, (fig. 43 A) be an assortment of small squares, in which the square BNDG, composed of 49 imperfect squares, represents the section of the nucleus*, and the extreme squares $t, p, i, B, f, c, s, c, h, \&c.$, the kind of steps formed by the laminæ of superposition. We may conceive that the assortment has commenced by the square BNDG, and that different piles of small squares are afterwards applied on each of the sides of the central square; for example, on the side BN: in the first place the five squares comprehended between f and h , afterwards the three squares contained between c and e , and then the square s . This progress corresponds with what would take place if the dodecahedron commenced by a cube proportioned to its volume, and which afterwards increased by an addition of laminæ continually decreasing.

But on the other hand, we may imagine that the assortment had been at first similar to that which we see (fig. 43 C), in which the square BNDG is only composed of nine molecules, and bears on each of its sides only a single square s, t, s', z . If we refer, in imagination, this assortment to the solid of which it is the section, we shall easily judge that this solid had for its nucleus a cube composed of 27 molecules, and of which each face, composed of nine squares, carried on that of the middle a small cube, so that the decrement by one range is already exhibited in this initial dodecahedron:

This assortment, by means of an application of new squares; will become that of fig. 43 B, in which the central square BNDG is formed of 25 small squares, and carries on each of its sides a pile of three squares, besides a terminal square s, t, s' , or z . Here we have already two laminæ of superposition, instead of one only. Finally, by an ulterior application, the assortment of fig. 43 B will be changed into that of fig. 43 A, where we see three laminæ of superposition. These different transitions, of which we are at liberty to continue the series as far as we please, will give an idea of the manner in which secondary crystals may increase in volume by preserving their form; from which we may judge that the structure is combined with this augmentation in volume; so that the law (according to which all the laminæ applied on the nucleus when it has

* This section is that which would pass by the points s, s' (fig. 11) of the dodecahedron, and by the centres of the ridges EO, AI, &c., of the nucleus. Thus the point B (fig. 43) is regarded as situated at an equal distance between the points E, O, (fig. 11.) and the point N, at equal distance between the points A, I, &c.

attained its greatest dimensions decrease successively,) was already, as it were, displayed in the growing crystal.

A great deal remains to be done before we can terminate the theory of crystallization. We have only given the laws of the structure of crystals, and we are now enabled to unravel those of their formation. The affinity of the molecules for each other, the nature of the liquid in which crystallization takes place, its degree of density, temperature, and other similar circumstances, would be so many elements which we ought to take into our calculation, and the solution of the problem would determine the law of decrement which ought to take place in each particular case in virtue of the same circumstances, and the form of the secondary crystal which would result from that law.

We can very well conceive in general, that stony, metallic, or other molecules, suspended in a liquid, and disposed to reunite in order to form a crystal, are attracted at the same time by each other, and even by the molecules of the liquid; and it is because their mutual affinity is stronger than that of the liquid that their union is produced. Now the attraction of the liquid varies on account of the circumstances which we have mentioned; and thus its difference from the mutual attraction of the molecules, which is always the same, ought also to undergo variations which influence crystalline forms in their diversity. And if there are heterogeneous matters in the liquid, they will act on their part in order to modify the action of the liquid on the true molecules. It would seem that we have a proof of this in certain crystals of axinite, one part of which is of a violet colour with manganese, and the other green, in consequence of chlorite being present. The former presents additional facets, which are not observed in the latter, which is besides more regularly formed, and has not a striated surface, like the violet part.

A superabundant portion of some of the essential principles, which would be, as it is said, *in excess*, might also have an influence on the form of the crystal, by adding its own particular action to that of the liquid. For it can hardly be doubted that there is for every substance a fixed proportion of principles, which constitute its true nature; so that all which exceeds the limit given by this proportion ought to be regarded as accidental, and assimilated to a heterogeneous substance.

But the above are only slight hints, by no means sufficient to clear up the subject. Our acquirements have more

progress to make, before geometry can have the data necessary for submitting to a precise and rigorous theory the combined forces of the different agents which concur in crystallization, and ascend from the facts already established, to other facts more general, and more allied to the true causes which depend immediately on the will of the Supreme Being. It is a rich mine, the working of which is merely commenced, and which waits for more favourable times and more scientific workmen to follow the vein to the greatest depth.

Of Crystals with a Moiety reversed, and of those which appear to penetrate each other.

We have hitherto considered crystallization as impressing on its results the character of the greatest possible perfection, and producing nothing but isolated forms, exempt from every thing that could affect their purity and symmetry. It remains for us to describe certain accidents, which, under the appearance of exceptions or anomalies, still possess a latent tendency towards the same laws to which the structure is subjected, when nothing deranges their progress or disturbs their harmony.

In ordinary crystals, the faces adjacent to each other always form saliant, and never re-entering, angles. But crystalline forms also exist which present these last angles; and Romé de l'Isle was the first who observed that this effect took place when one of the two moieties of a crystal was in a reversed position with respect to the other*. A very simple example will enable us to conceive this reversal.

Let us suppose that Bd (fig. 44) represents an oblique prism with rhomboidal bases, situated in such a manner that the panes $ADda$, $CDdc$, are vertical, and BD are the acute angles of the base; and the latter proceeds in a rising direction from A to C . Let us, besides, suppose that the prism is cut into halves, by means of a plane which should pass by the diagonals drawn from B to D , and from b to d , and that, the half situated on the left remaining fixed, the other half is reversed without being separated from the former. The crystal will be presented under the aspect which we see in fig. 45, where the triangle $b'd'c'$, which was one of the halves of the lower base (fig. 44), is now situated in the upper part (fig. 45), and forms a saliant angle with the fixed triangle ABD , while the triangle

* Romé de l'Isle.—Crystal. t. i. Introd. p. 93.

BDC (fig. 45), which was one of the halves of the superior base (fig. 44), is transported into the lower part (fig. 45), and forms a re-entering angle with the fixed triangle abd .

We can easily conceive that the plane of junction $DBbd$ of the two halves of a rhomboid, is situated like a face produced in virtue of a decrement by one range on one or other of the ridges Aa, Cc , (fig. 44); and thus the manner in which these two halves join is in strict relation to the structure.

Now if we imagine a secondary form which has for its nucleus the same prism, and if we suppose that it has been cut in the directions of the plane $DBbd$, and that one of its halves is reversed in such a manner that the half of the nucleus which corresponds with it assumes the same position as in the preceding case, the assortment might be such that there is still a re-entering angle on one hand and a salient angle on the other, which will result from the mutual incidences of the faces produced by decrements.

In certain cases the plane of junction, on which the two halves of the crystal are joined, is situated parallel to one of the faces of the nucleus, and the assortment does not admit of presenting a re-entering angle opposed to a salient angle.

I have given to these reversed crystals the name of *hemitropes**, and I call *hemitrope crystals* such as are thus reversed. They seem to indicate a polarity in the integral molecules, as I shall explain more at length under the head of *spinell*. We shall also find under the articles *feld-spar*, *pyroxene*, *oxidated tin*, &c., remarkable examples of hemitropes.

Another accident extremely common, is the manner in which grouped crystals are inserted into each other †. This kind of *apparent* penetration is subject to so many diversities, that frequently, among crystals of the same group, we do not find two relative positions resembling each other. We must except, however, staurotide, the prisms of which, as we shall see, have their junction limited to two particular cases, which we shall make known when treating of the crystallization of this substance.

But although in general the positions in grouped crystals are infinitely variable, we find, on a closer examination,

* Romé de l'Isle calls them *nacles*. But this name being already applied to a very common species of mineral, I have thought proper to avoid the double application of the term.

† The German word *ause* is sometimes used to designate a group of crystals.

that they are subjected to certain laws always analogous to those of the structure; and that these crystals, instead of being tumultuously precipitated on each other, have in some measure concerted their arrangement.

Let us also on this occasion choose a very simple example. Let AC' (fig. 46) be a cube, and MNR an equilateral triangular facet produced in the place of the angle A , in virtue of a decrement by one range round this same angle. Let us suppose a second cube modified in the same manner, and fastened to the former by the facet which results from the decrement indicated. We shall thus have the assortment represented by fig. 47.

We may now conceive that one of the two cubes, that for example which is placed below, is increased in all its dimensions, except at the places where the other forms an obstacle to it. In proportion as this increment becomes more considerable, the upper cube will be more and more engaged in the inferior one, and it may even finish by being entirely masked or concealed by it. We observe crystals effectually sunk into each other at various depths; but which have always a plane of junction situated like a face produced by a decrement, in such a manner that the two structures follow their ordinary progress, each on its own part, the length of this same plane, which serves as their respective limit. I have divided cubes of fluated lime inserted into each other; and I have remarked that the laminæ of each extended without interruption, until suddenly stopped by the common plane of junction.

The example now quoted relates to a very simple and very regular law of decrement. But frequently the laws which determine the plane of junction are more or less remote from this simplicity, and there are a few which are somewhat extraordinary.

When two prisms cross towards the middle of their axes, there are two planes of junction, which unite, crossing each other on one common line, as we shall find under the article *staurotide*, and both these planes also have positions analogous to those which would be determined immediately by laws of decrements.

To conclude: I have here presented the results of but a small number of particular observations. I propose afterwards to resume the subject now glanced at, and to give a fuller development to the theory of which I think it susceptible,

[To be continued.]

L. *An Examination of the Review which appeared in the XIIIth Number of "The Retrospect," &c., of Doctor HERSCHEL'S Essay on the coloured Rings discovered by Sir ISAAC NEWTON.*

To Mr. Tilloch.

SIR, THIS paper is transmitted to you by a little club of friends who occasionally meet together for conversing on philosophical subjects, and who suppose that what is now communicated may be made welcome to a place in your very impartial and valuable Magazine.

For some time past our chief object has been to consider more particularly of the progress of discovery in the different branches of physical science, by the increasing ardour for experimental researches, happily now so prevalent both on the continent and in our own country; and which reflects so much lustre on the present times.

Though our reading is pretty extensive in original and other publications of this sort both foreign and domestic, yet it was not till lately we met with some numbers of a periodical work called "*The Retrospect*," &c., which first appeared a few years ago. From the plan of that publication and its high pretensions, as stated in the general title, we had some curiosity to dip into it; when very soon we found our attention arrested by a review of an experimental essay under the following title: "Experiments for investigating the Cause of the coloured concentric Rings (discovered by Sir Isaac Newton) between two Object-glasses laid upon one another. By William Herschel, LL.D., F.R.S."

When that paper first appeared in the Philosophical Transactions of the Royal Society of London, we well remember to have perused it with high satisfaction; not only on account of the remarkable skill discovered by the author, in bringing forward many new and curious experiments leading to important conclusions, but also because the structure of the whole piece appeared to us as an example of the inductive method of proceeding in natural philosophy worthy of ranking with the best models we have of the kind.

We therefore need scarcely mention our surprise at finding that nothing whatever of that subtle and elaborate performance was held of any account by the writer who furnished that review of it for the 13th Number of *The Retrospect*.

Though to those who have studied optics, any vindication

tion of the experimental essay in question is surely unnecessary, yet it may not be amiss to do something in this way, for the sake of disabusing many other very intelligent persons who otherwise might be misled by criticisms as confidently delivered by this reviewer as they appear to us, one and all of them, ill founded.

It would be a very unlucky issue indeed, especially of experimental researches, when pursued by a man of Doctor Herschel's abilities, to be wholly destitute of value. Nevertheless this reviewer, as has been already noticed, from the beginning to the end of his lucubrations on the essay, very carefully inculcates that it ought to be so estimated.

Though we are far from questioning the right of private judgement, especially within the calm precincts of philosophy, yet we are of opinion that fair controversy will here always reject an union with the passions; and that the love of truth for its own sake, when it is in reality the governing principle, will sweeten opposition, and join together antagonists in sincere and mutual esteem.

Accordingly, on the present occasion, from the many prefatory eulogiums on the author of the essay, we naturally expected, along with any power of argument, gentleness and decorum on the part of the reviewer, when exposing the imagined failures of a person who has done so much for science, and who in every view of his character was so highly entitled to consideration.

In place of that deference, however, which we looked for, and which certainly would in no way have weakened the force of the reviewer's fancied refutations, the very contrary seems to be indulged in. Every thing in the course of his strictures, in point of manner, is so sour and supercilious, and so totally exclusive of approbation, as very ill corresponds with any measure of complacency, or respect for the author of the essay. This, when confronted with that ample store of compliment and encomiums which usher in the strictures, is in some danger, we fear, of being viewed by many as a very gross inconsistency; and so far, perhaps, the reviewer has been unfortunate in exposing the cordiality of his professions to some degree of doubt.

At a meeting of our little circle lately, this wayward sort of see-saw of first writing an author so handsomely *up*, and then immediately so completely *down* again, was not spared. One observed, tartly, that so novel and incongruous a plan of criticism was like wrapping up garlic and assafœtida in verveil and rose leaves: another, that he never yet had found the sprinkling of lavender or Hungary water entirely to
countervail,

countervail, when any unsavoury thing had got behind the wainscot: a third exclaimed, with more archness of manner, that it was a right cunning experiment, and by all the world like applying, what he whimsically called, a metaphysical syphon to the merit of an author; by which, in the first instance, the merit was indeed made to mount up, but as certainly, added he, shaking his head, to wheel round to the contrary direction; till by degrees the whole stock should be drawn off, in the way of hocus-pocus, by the preponderant bias in the longer leg.

But to interpose a little in favour of the reviewer, from a wish of reconciling appearances, it is only fair to consider, as he himself indeed expressly warns us to do, that whilst he was blowing so warm on the author by panegyric, yet so miserably cold on his essay, almost in the same breath, he lay under a conflict between his great respect for Doctor Herschel and his paramount obligation to fidelity, when delivering his awards in philosophical matters, for the edification of the public.

It comes therefore, in the next place, to be examined how far the solidity of this reviewer's *matter* can justify that fervour of his critical zeal which, on the present occasion, has led him to be so fastidious and magisterial; under the great delusion, as it should seem, of his being so warranted on the score of duty, that he might give the greater consequence and currency to his critical manifestos.

For prosecuting, in the hopes of success, a subject well known to be important, and also of a recondite nature, Doctor Herschel, in the true spirit of experimental philosophy, conceived that every thing depended on a full discovery of the phænomena of the coloured rings he treats of in his essay, as far as they could be traced by the most diligent and varied trials. Before he entered on these experiments no philosopher had ever seen but one set of rings, namely, that discovered and treated of by Sir Isaac Newton. But whilst viewing that beautiful appearance as produced by the contact of the famous Huygenian lenses, Dr. Herschel detected between his glasses several other sets of coloured rings, which, by the peculiar construction of his apparatus, were formed at the same time. To a person then employed as he was, such very new phænomena could not but be deemed most worthy of attention. Nor will it be asserted, along with the reviewer, by any one who has pretensions to science, that to examine their nature and peculiarities could be of no avail. The fact is, as appears from the essay, that this patient and acute philosopher has, with
remarkable

remarkable success, observed those new sets of coloured rings whilst undergoing a variety of surprising and intricate changes, all of which he has reduced to order, and fully explained. From this store of facts, entirely new, he has moreover established, beyond all contradiction, the four general propositions, in pages 47 and 48 of his paper, concerning the formation of the Newtonian rings themselves.

This reviewer, however, makes very short work in declaring the whole of this research as good for nothing. For in the 13th Number of *The Retrospect*, page 24, it is said, "The principal novelty of those experiments appears to be the unnecessary complication that is introduced into them; the rings, exhibited by a series of successive reflections, are confessedly repetitions of those which Newton observed in a simpler form: and from this complication Doctor Herschel obtains only *fumum ex fulgore*." Indeed! highly decorous latinity to be sure, and given us, by way of boast, in an appropriate character.

We can scarcely conceive any thing more unreasonable, or less worthy of a serious reply, than this most strange objection to such a detail of instructive experiments as has been just alluded to; and on the unmeaning grounds that the rings exhibited by a series of reflections are unnecessary complications, because repetitions of those which Newton observed in a simpler form. For on that very account, of their being so seen by a series of reflections, much knowledge has been derived concerning the nature of all the rings. This has been most particularly and clearly shown in the essay.

Had this reviewer lived in the days of the celebrated Hadley, the inventor of that noble instrument known all over the world by his name, he surely, according to his seeming capacity of judging of matters of this kind, would have thought Hadley very idly employed in having to do with the moon and stars by means of reflections, when to be seen at a single glance in the reviewer's simpler form: and yet it is well known that by the aid of seeing these luminaries by reflections a great object was accomplished, for the benefit of mankind, by the construction of the sea quadrant. Or let us ask the reviewer, what is the case when viewing distant objects through a telescope? Here also we find that by having availed ourselves of a little of that complication so decried by the reviewer, and of images formed by reflections, we see much further, and much better, than he could do by looking at the same things in their simpler form as he calls it; that is, without

the

the help of the telescope. The simplest of all simple forms the reviewer will admit is that of the sphere: yet Archimedes, when investigating several curious properties of that solid, doubtless employed many reflections; and the reviewer might impugn the demonstrations of that geometer as unnecessary complications, with as much justice as he has done Doctor Herschel's proofs proceeding from reflections also, both mental and optical. In short, what is found in the foregoing quotation is so flimsy as to debar all philosophical discussion, and cannot be gravely replied to.

Another of the strictures is the following: (Retrospect, page 23, line 4, from bottom; when the reviewer, speaking of Dr. Herschel's essay, says,) "We cannot consider it by any means as adding to the value of those treasures of science, which have in the course of years been accumulated in the Philosophical Transactions." The reader need not be here told how much those justly celebrated volumes have derived their importance by recording knowledge supported by experience as science in its best form. In reply, therefore, to the passage just now quoted, we shall have an opportunity of entering a little more particularly into the nature of Doctor Herschel's experiments and proofs, by putting a few questions to the reviewer.

Considering the avowed importance of the subject, is it not an addition to our stock of knowledge to have been made acquainted with many different ways of obtaining a sight of these coloured rings; not only by means of glasses, but of metals? See the essay, articles 1, 2, 3.

Is it not an addition to our stock of knowledge to have discovered and shown that the colours of these different sets of rings are alternate? (see article 14,) and to have explained the cause of that alternation? See article 17.

Is it not an addition to our stock of knowledge to have shown that the colour of the rings, as well as their size, can be suddenly changed, according to an invariable law, by the interposition of shadows? (see article 15,) and to have explained the cause of these changes? See article 18.

Is it not an addition to our stock of knowledge to have proved also by experiments, the four propositions in pages 47 and 48 of the essay, relating to the action of the several surfaces as contributing to the formation of the coloured rings?

Is it not an addition to our stock of knowledge to have shown that from a polished metalline speculum we can obtain most beautiful coloured irises? See article 33.

If the reviewer still continues his negative to those questions, his notions of knowledge and science must be of some very peculiar conformation.

Further, in *The Retrospect*, pages 23 and 24, it is said: "Doctor Herschel seems to have confined his study of the phænomena of light almost entirely to the works of Newton." And was not his doing so, in this paper, highly proper; when he was, by experiments, investigating the cause of the coloured rings discovered by Newton? It is immediately added, "not thinking it worth his while to inquire whether the last hundred years had produced any thing deserving his attention; and taking it also for granted, that little or nothing was known before him," &c. This, and some other morsels of the like sort, which are passed over, nearly rival in elegance the reviewer's *fumum*, &c. But as nothing whatever is to be found in the essay that can show what the author takes for granted, we are quite at a loss in conjecturing who has let the reviewer into that secret.

Again, in *The Retrospect*, p. 24, line 6, it is said, "But, in fact, the colours of those plates were by no means the discovery of Newton; they have been described with great accuracy by the ingenious, but too much neglected, Doctor Hook." Here the reviewer discovers a laudable sympathy and concern for departed merit; but we find nothing in the essay which could induce him thus to conjure up the shade of that philosopher. The tendency of the passage last quoted, though it cannot be supposed intentional, is to fasten a charge of ignorance on the author; as if he had ever maintained that the phænomena of these coloured thin plates were the discoveries of Newton. The author in his essay has never alleged any such thing. He has said, indeed, and truly, both in his title and elsewhere, that the coloured rings were discovered by Newton. This it is well known Newton did by making use of prisms, and at last object-glasses, brought into contact. See Newton's *Opticks*, book II., part I. observations 2, 3, 4.

Again, in *Retrospect*, page 24, we find as follows: "The experiment made by strewing particles of hair-powder in a sunbeam, is still more unconnected with the question." The most evident and close connection of that experiment with the subject will be best seen by Doctor Herschel's own words; when it is considered that he was then bringing his proofs from experiment to bear against the existence of the fits of easy reflection and easy transmission of light.

As a reason for pronouncing that experiment unconnected

nected with the question the reviewer adds: "Because the rays of light undergo certain flexions and modifications in the neighbourhood of bodies near which they pass, it surely does not follow that they are not liable to other modifications at the surfaces of transparent bodies. In fact, these colours are identical with those of the coronæ described by Mr. Jordan and other authors."

The reviewer must have been slumbering when he would have the reader to believe Doctor Herschel had still to learn from him that light may be liable to modifications at the surfaces of transparent bodies; since the close investigation of *those very modifications* makes the sole business of Doctor Herschel's essay, from the beginning till very near the end. This hypothesis of the reviewer's inattention is further confirmed by what is immediately added in the conclusion of the last quotation. There the originality of the experiment alluded to has wholly escaped him; for he mentions it as nothing but what had before been familiar to Mr. Jordan and other authors.

But to proceed: The proofs which the author has brought forward against the existence of the fits of easy reflection and easy transmission of light are detailed in the 31st and 32d articles of his essay, and may be considered as the most important part of it; as leading on to new views and improvements of Sir Isaac Newton's philosophy of light and colours.

Let us therefore next see what the reviewer has given us about this. The quotation is from the 24th page of *The Retrospect*. "We do not wish to be considered as strenuous defenders of the Newtonian fits of easy transmission and easy reflection; but we will venture to maintain that Doctor Herschel has advanced no one argument that can have any weight in lessening the probability of their existence." And in five lines further on, it is added: "Nor had Doctor Herschel any reason to expect a sensible change in the appearance of the rings, when they were viewed through the wedges of air and glass which he describes, since those wedges were much too thick to produce any observable colours in white light, and for the same reason too thick to produce any perceptible interruptions in the rings*; the effects of the interruptions of two portions of light, differing but very little in refrangibility, being so different as to counteract each other."

Now really in the whole of this, till we come to the *asterisk*, there is nothing to be found in the form of argument. That the wedges described by Doctor Herschel were much

too thick cannot surely be admitted on the reviewer's *ipse dixit*. This position ought to have been established by some proof, not by naked assertion; since the author, in his paper, had so minutely shown that the thickness of his wedges was such as to warrant his conclusions. The truth is, that the reviewer here contradicts not Doctor Herschel, but Sir Isaac Newton, who has proved that plates of air between his object-glasses, as thick, and a great deal thicker than many to be found in Doctor Herschel's wedges, will produce observable changes in white light.

Newton, in his *Opticks*, edition 1721, page 178, determines experimentally the thickness, in parts of an inch, of his plates of air at the first, second, third, fourth, fifth &c. ring, as respectively equal to a fraction whose constant denominator is 178000, and the numerator according to the series 1.3.5.7.9, &c. These were the thicknesses of the respective plates of air between his object-glasses, when his eye was placed perpendicularly in the axes of the rings. Further, in page 179, he determines all these different thicknesses when he viewed the rings obliquely. By his table, given us in that page, it appears that any individual ring of a given diameter, with a certain thickness of air at that place, will, when seen in the most oblique position, be increased 3.5 times in diameter, and that the thickness of the plate of air at the same place will be increased 12.25 times.

As to the number of rings which can be perceived and counted, Newton mentions that, under favourable circumstances, he has sometimes seen more than twenty of them; and in the usual way eight or nine. But even supposing we could see none beyond the limits of the eighth ring, the question before us is, what would be the thickness, according to Newton, of the plate of air at that place? This, when the eighth ring is seen perpendicularly, with the object-glasses which Newton used, will be $\frac{15}{178000}$ according to the foregoing progression of the fractional numerators; and when seen obliquely $\frac{15 \times 12.25}{178000}$ equal to $\frac{18375}{1780000}$ equal to $\frac{1}{969}$ parts of an inch. Here then we have the authority of Sir Isaac Newton for saying that a ring will be formed and perceivable when light passes through a plate of air of $\frac{1}{969}$. The reviewer will not deny that the production of a ring is a change made on white light.

Now

Now the thickness of Doctor Herschel's plate of air or wedge at its greatest opening is stated, in his paper, to be $\frac{1}{640}$ part of an inch. This wedge was 5.6 inches in length; and an easy calculation will show that from the sharp end, forward for three inches, the thickness (increasing from zero all the way) did not exceed that determined as above by Newton. This, it is presumed, will be sufficient to show that Doctor Herschel's wedge of air was thin enough for his purpose; and that any individual ring of a secondary set, when seen within three inches from the sharp end, must appear broken or interrupted in such parts as let through the rays of its own colour, granting they were in fits of easy transmission at their incidence on the undermost plate of the wedge.

But it might have been assumed that 12 rings, instead of 8, may be rendered perceivable by Newton's object-glasses; in which case the thickness of the plate of air at that place will be $\frac{1}{632}$ parts of an inch, which is greater than the greatest opening of Doctor Herschel's wedge.

Let us now return to the last quotation from *The Retrospect*; in order to consider the import of The two lines which follow the *asterisk*. There we meet, for the first time in the whole course of the strictures, with something having the form of an argument. The reviewer tries to prove that certain counteractions will take place to prevent the breaks or interruptions of the secondary rings from being perceivable, because the wedge of air, in his opinion, is much too thick. But though we certainly should have welcomed any opportunity of philosophical discussion on a topic of this kind, yet we are obliged to declare that, after having repeatedly and carefully endeavoured to catch the meaning of these two lines, they appear to us altogether unintelligible; and we are persuaded they must be so judged of by every one conversant about optics. We are, however, far from saying that the reviewer had not in his mind some meaning or other which bore on him, very cogently, in support of such counteractions: but surely he must have thought very highly of his powers of elucidation, if he really expected in the compass of two lines to enlighten his readers, and establish his conclusions, on a point of this kind. But as these his conclusions, by his own admission, depend on Doctor Herschel's wedges being much too thick, the contrary of which has been made evident, it cannot be expected that such supposititious and imaginary counteractions

counteractions are to set aside Doctor Herschel's proofs deduced from facts. At the same time, could the reviewer have made some stand on this ground, and had he condescended to have illustrated intelligibly the sources of his contradiction, we should have respected such an instance of philosophical scrutiny and such an invitation to candid disquisition. But in place of that, this reviewer all of a sudden chooses to envelop himself in that smoke he has so ready at command; and so vanishes in a cloud of abortive and fathomless opinions.

To conclude: It is well known that the fits of easy reflection and easy transmission, imputed to the rays of light by Sir Isaac Newton, have long been considered as a part of his philosophy in some measure doubtful. In the essay at present under consideration, the author has the merit of *formally* bringing this celebrated theory to the only test which can finally determine its pretensions, and set so important a question for ever at rest. If, when thus sifted by a more enlarged experience, and by so skilful a hand, it has been reserved for Doctor Herschel to show its fallacy, yet no generous mind will be disposed to grudge him that success, or to venerate the less the name of NEWTON, though one of his most earnest and most illustrious followers has so improved his philosophy, even by clearing it of his own mistakes: any advances of this kind, even at such a price, we cannot doubt would have been hailed by Newton himself. That truly great and excellent person had far more wisdom as well as humility than to harbour the weak and preposterous ambition of being accounted infallible as a MORTAL. Any lapses, however, that can be ascribed to him, figure only as small spots do on the meridian sun, considering that effulgence of science struck out of darkness by the sublimity of his genius, and which he has bequeathed to mankind. In the present instance, whatever new scion is destined to adorn the philosophy of light and colours, in consequence of the advances now made by Doctor Herschel, one thing is certain, that it must derive its vital growth by being grafted on that tree of knowledge still sound at the core, first planted by the hand of Newton, and which cannot but ever endure and flourish, to be beheld by all eyes as one of the monuments of his glory!

LI. *Experiments on Ammonia, and an Account of a new Method of analysing it, by Combustion with Oxygen and other Gases; in a Letter to HUMPHRY DAVY, Esq., Sec. R.S. &c., from WILLIAM HENRY, M.D., F.R.S. V. P. of the Lit. and Phil. Society, and Physician to the Infirmary at Manchester*.*

MY DEAR SIR †,

I SHOULD sooner have communicated the account, which you are so good as to request, of my further experiments on the decomposition of ammonia, if I had not been anxious to obtain, by frequent and careful repetition of them, results not affected by any of those numerous causes of error, which easily insinuate themselves into processes of so much delicacy. You have already been informed that the fact, which I lately mentioned to you, (tending to prove the existence of oxygen as an element of the volatile alkali, by the discovery of oxygen gas in the products of its analysis,) is not entitled to confidence, owing to the admission of a small quantity of atmospherical air in a way which was not at all suspected. Frequent repetitions of the same process, under circumstances wholly unobjectionable, have fully satisfied me that no portion whatsoever of oxygen gas is evolved by electricity from ammonia even when, by means of an apparatus constructed for the purpose, the only metallic surface exposed to the gas consists of the sections of two platina wires, each 1-50th of an inch in diameter, the wires themselves being inclosed in glass tubes which are sealed hermetically round them, and then ground away, so as to expose only the points. Nor does any difference in the nature of the products arise from electrifying the gas either under increased or diminished pressure, the latter of which, it appeared to me probable, from the known influence of elasticity in impeding the combination of gaseous bases, might prevent the oxygen of the alkali from uniting with hydrogen to form water, and occasion the expansion of both into the state of gas.

Having failed, therefore, to acquire, in this way, proof of the existence of oxygen in the volatile alkali, I was next led to seek for some unequivocal mode of evincing the pro-

* From Philosophical Transactions for 1809.

† This letter, in its original form, was read to the Society May 18, 1809, some new observations were added, and some corrections furnished by the author, in consequence of subsequent experiments made in June: it was transmitted to the secretary for publication July 10.

duction of water by the same operation; a fact, which would be scarcely less satisfactory in establishing oxygen to be one of its constituents, than the actual separation of oxygen gas. The most careful observation of ammonia, during and after the agency of electricity, does not discover the smallest perceptible quantity of moisture. In order, therefore, to subject the gas to a satisfactory test, I had recourse to the following contrivance:—Ammoniacal gas, I had previously found, may be so far desiccated by exposure to caustic potash as to show no traces of condensed moisture, on the inner surface of a thin glass vessel containing it, when exposed to a cold of 0° Fahrenheit; though the recent gas, by the same treatment, is made to deposit water in the state of a thin film of ice. A glass globe, of the capacity of between two and three cubical inches, was filled with gaseous ammonia, which was then dried by sticks of pure potash, fastened to pieces of steel wire, so that they could be withdrawn after having exerted their full action. This point of dryness was ascertained by applying ether, or a mixture of snow and salt, to the outside of the globe. By means of a peculiar apparatus, the gas was next strongly electrified, and the cooling power was again applied to the outer surface of the globe.

In the first trials that were made with this apparatus water certainly seemed to have been formed by the electrization of the alkaline gas; for the same portion of gas, which was not affected by a freezing mixture before the process, gave evident signs of condensed moisture when the cooling power was applied after long continued electrization. The appearance was not only quite satisfactory to myself, but to Mr. Dalton, and several other chemical friends, to whom I showed the experiment. Finding, however, that the appearance varied as to its degree, I was induced to repeat the process with redoubled precaution; filling the globe, previously heated, with hot mercury, and drying, not only the quicksilver, but the iron cistern which contained it, by exposure to long continued heat. The electrified gas now betrayed no signs of moisture on the application of a temperature 20° of Fahrenheit, and gave only the smallest perceptible traces by a cold of 0° or a few degrees below. I cannot help suspecting, therefore, that the moisture manifested in the earlier experiments was derived from the mercury or from some extraneous source, and was not generated by the action of electricity*.

* It may be objected, I am aware, that as the gases produced from ammonia are nearly double its original bulk, they may hold in combination
any

The avidity with which ammonia retains moisture, and again absorbs it when artificially dried, is very remarkable. A confined quantity of common air may be completely desiccated, in the space of a few minutes, by pure potash, or by muriate of lime; so that no ice shall appear in the inner surface of the containing vessel when exposed to a cold of -26° of Fahrenheit. But ammonia requires exposure during some hours to potash, to stand the test even of 0° Fahrenheit; and a single transfer of the dried gas, through the mercury of a trough in ordinary use, again communicates moisture to it. Muriatic acid gas, freed merely from visible moisture, deposits no water at the temperature of 26° Fahrenheit. This is probably owing to its strong affinity for water; for electricity, after the full action of muriate of lime, evolves, as I have lately ascertained, about 1-35th its bulk of hydrogen gas; the recent muriatic acid gas giving about 1-14th after the same treatment*.

From the average of a great number of experiments on the decomposition of ammonia by electricity, I was for some time led to believe that you had rather under-stated the proportion of permanent gases obtainable from it by this process (viz. 103 measures of permanent gas from 60 of ammonia, or 180 from 100). For the most part, I had found the bulk of ammonia to be doubled by decomposition, even when the gas was previously dried with extreme care. In one instance a small bit of dry potash was left in the tube, along with the ammonia, during electrization, with the view of its absorbing water, which I supposed at that time to be generated by the process. In this case, 59

any water that may have been generated by electricity. But though this supposition may explain the non-appearance of visible moisture, it does not account for the inefficiency of a powerful cooling cause to discover traces of watery vapour; for this is a test which renders apparent very minute quantities of water in gases.

* In a course of experiments, which I have described in the Philosophical Transactions for 1800, it appeared that muriatic acid gas, after being dried by muriate of lime, gave nearly as much hydrogen by electrization as gas which had not been thus exposed. I was not however aware, at that time, of the extreme caution necessary in experiments of this kind; and was satisfied with transferring the acid gas from a large vessel, in which it had been dried, into the electrizing tube, a mode of proceeding which I now find to be quite inadmissible. The action of muriate of lime, which has undergone fusion, on muriatic acid gas, is rendered very sensible, when considerable quantities are used, by the evolution of much heat, and by a diminution of the volume of the gas. Ammonia also is contracted in bulk by dry caustic potash. Muriate of lime cannot be employed for its desiccation, since this substance rapidly absorbs the alkaline gas, even when the gas has been previously exposed to quicklime. In this case the ammonia attracts a portion of muriatic acid from the earthy salt agreeably to the law of affinity, which has been so ably illustrated by Berthollet.

measures (each = 10 grains of mercury) became 115. The following table shows the expansion of various quantities of ammonia.

Exp.		
1.	60 measures of ammonia gave permanent gas	112
2.	60 - - - - -	120
3.	59 (potash being left in the tube) -	115
4.	55 - - - - -	115
5.	75 (under the pressure of half an atmosphere)	150
6.	65 - - - - -	180
7.	65 - - - - -	130
8.	53 (one of the conductors being of steel wire)	106

492

978

and 492 : 978 :: 100 : 195.78. These proportions, you will find, correspond very nearly with those long ago stated by Berthollet*, who converted 17 measures of ammonia by electrization into 33 measures of permanent gas, which is at the rate of 194 from 100. Having lately, however, carried on the process with the observance of additional precaution, (the mercury being first boiled in the tube, before admitting the ammonia, and still remaining hot when the gas was passed up,) I have obtained from the alkali less than double its volume of permanent gas, viz. 280 measures from 155, or at the rate of 180.6 from 100. The variableness of the first set of results arises, I believe, from the uncertainty of the quantity of ammonia decomposed. For if the smallest portion of moisture remain in the tube, a little ammoniacal gas will be absorbed, and will be slowly given out again as the electrization goes on, thus rendering the actual quantity submitted to experiment greater than appears. It is probable also, from a fact which I shall afterwards state, that mercury itself, unless when heated, may absorb a small portion of alkaline gas.

The proportion of the hydrogen and nitrogen gases to each other in the products of ammonia decomposed by electricity, I am satisfied by recent experiments (June 1809) is as nearly as possible what you have determined, viz. 74 measures of hydrogen gas to 26 of nitrogen. The nearest approximation I have made to these numbers is 73.75 to 26.25. Our only method of analysing mixtures of these two gases (viz. by combustion with a redundancy of oxygen) is not, I believe, sufficiently perfect to afford a nearer coincidence.

.. The extreme labour and tediousness of the decomposi-

* *Journal de Physique*, 1786, ii. 176.

tion of ammonia by electricity influenced me to attempt the discovery of a shorter and more summary method of analysis. The most obvious one was its decomposition by oxymuriatic acid gas; but this plan was abandoned, from the impossibility of confining both the gases by any one fluid; since the water acts powerfully on the one, and mercury on the other. But a mixture of oxygen and ammoniacal gases more than answered my expectations. When mingled in proper proportions, these gases, I have ascertained, may be detonated over mercury by an electric spark, exactly like a mixture of vital and inflammable air; and the results of the process, with due attention to the circumstances, which will soon be stated, afford an easy and precise method of analysing, in the space of a few minutes, considerable quantities of the volatile alkali. With a greater proportion of pure oxygen gas* to ammonia than that of three to one, or of ammonia to oxygen than that of three to 1.4, the mixture ceases to be combustible. When the proportions best adapted to inflammation are used, oxygen gas may be diluted with six times its bulk of atmospherical air, without losing its property of burning ammonia.

Atmospherical air alone does not, however, inflame with ammonia in any proportion that I have yet tried; though, by long continued electrization with air, ammonia is at length decomposed; its hydrogen uniting with the oxygen of the air and forming water, while the nitrogen of both composes a permanent residuum. Forty-five measures of ammonia being electrified with eighty-six of common air, the total 131 became 136, and 132 after being washed with water. Of 17.2 measures of oxygen, contained in the 86 measures of air at the outset, only 2.9 were left, and these also would probably have disappeared by continuing the operation. If a mixture of ammonia and atmospheric air, each previously dried by caustic potash and then electrified, be examined, the production of water is made sufficiently apparent on applying ether to the containing vessel. In subjecting ammonia, therefore, to this test of the generation of water by electricity, the purity of the gas from atmospheric air should be carefully determined †.

The products of the combustion of ammonia with oxy-

* Containing only three or four per cent. nitrogen gas.

† The result of this experiment shows, moreover, that even supposing oxygen to be a constituent of ammonia, we are not to expect its evolution, in a separate form, by electricity; since, when electrified with ammoniacal gas, oxygen gas is deprived of its elastic form, and its base is condensed into water by union with nascent hydrogen evolved from the alkali.

gen vary essentially according to the proportion of the gases which are employed. If the oxygen gas exceed considerably the ammonia (that is, if its volume be double or upwards) the ammonia entirely disappears, and no gases remain, but a mixture of nitrogen with the redundant oxygen. The moment the detonation is completed, a dense cloud appears*, and soon afterwards settles into a white incrustation on the inner surface of the tube. The quantity of this substance which is produced is too minute for analysis; but its characters resemble those of nitrate of ammonia, the acid ingredient of which is probably generated by the action of oxygen on the nitrogen of one part of the volatile alkali. Accordingly, when the excess of oxygen is removed by sulphuret of lime, the nitrogen generally falls short of the proportion which ought to accrue from a given weight of ammonia; and hence it is scarcely possible to attain, when a considerable excess of oxygen is used, an accurate analysis of the volatile alkali.

When, on the contrary, the ammonia exceeds considerably the oxygen gas, no production of nitrous acid appears to take place; for the residue, after detonation, is quite free from cloudiness. It is remarkable, however, that ammonia when fired, in certain proportions, with less oxygen than is required to saturate its combustible ingredient, is nevertheless completely decomposed. Part of its hydrogen is sufficient for the saturation of the oxygen; and the remaining hydrogen, and the whole nitrogen of the ammonia, together with that existing as an impurity in the oxygen employed, remain in a gaseous state, and compose a mixture, which may be inflamed by adding a second quantity of oxygen gas, and passing an electric spark †. In this way all the hydrogen of the volatile alkali may be saturated with oxygen, and condensed into water; and the whole of the nitrogen may be obtained as the final result of the process. After determining the amount of the oxygen consumed both in the first and second combustions, it is

*In some cases I have observed, that when the cloud does not occur immediately, it may be made to appear by agitating the quicksilver contained in the detonating tube. This is probably owing to the disengagement of some ammonia, which had lodged in the mercury. The fact confirms what I have already suggested respecting the cause of the variable proportion of gases evolved from ammonia by electricity.

† This is analogous to what happens when ether, alcohol, or any of the aeriform compounds of carbon and hydrogen, are exploded with a deficient proportion of oxygen; for much of the hydrogen is found in the residuum in the state of gas, and again becomes susceptible of combustion after the addition of a second quantity of oxygen. (See Mr. Cruickshank's excellent papers in the fifth volume of Nicholson's Journal, 4to.)

easy to calculate the quantity of hydrogen in the saturation of which it has been employed; for, when no nitrous acid has been formed, the hydrogen will be pretty exactly double in volume the oxygen which has been expended.

These general observations will tend to render the following experiments more intelligible. They may be divided into two classes; 1st, those in which ammonia was fired with an excessive proportion of oxygen; and 2dly, those in which the oxygen used in the first combustion was insufficient, or barely adequate, to saturate the whole hydrogen of the alkali.

I. *Decomposition of Ammonia by an Excess of Oxygen Gas.*

Twenty-two measures and a third of ammonia were mixed with $44\frac{2}{3}$ oxygen containing 43 of pure gas. The total 67 became 34 when exploded. Water did not produce any further diminution, but sulphuret of lime left only 8 measures. Now, $34 - 8 = 26$ shows the quantity of oxygen gas which escaped condensation; and this, deducted from the original quantity (43), gives 17 measures for the amount of the oxygen expended. The last number 17, being multiplied by 2, gives 34 for the hydrogen apparently consumed. The final residue $8 - 1.66$ (the nitrogen introduced by the oxygen gas) = 6.34 is the nitrogen obtained from $22\frac{1}{3}$ of ammonia; and if to this the hydrogen be added, 40.34 measures of permanent gas will be the total result. Hence 100 measures of the gas producible from ammonia, should contain 84.29 hydrogen and 15.71 nitrogen; numbers too remote from those, which have been already assigned, to be considered even as approximations to the truth. The error arises from the combination of oxygen, during combustion, not only with the hydrogen, but with the nitrogen of the alkali, the latter of which consequently appears deficient, and the former proportionably in excess.

Frequent repetitions of this combustion, with a considerable excess of oxygen gas, continued to give a deficient proportion of nitrogen; and as no accurate conclusions can be drawn from experiments of this kind, I shall proceed to those of the second class.

[To be continued.]

LII. *Observations on the Leech-worm.*

To Mr. Tilloch.

Bawtry, Nov. 5, 1809.

SIR, SOME years ago my attention was directed to make observations on the leech-worm as a weather-glass: these were published in *The Gentleman's Magazine* 1804; since which period I have had many opportunities of noticing several particulars respecting them; these are here committed to paper, to stimulate the curious to an inquiry into the cause of this phænomenon. If these observations should tend to the object in view, and be worth the perusal of the public, you will be kind enough to insert them in your *Miscellany*. I am, sir,

Your most obedient servant,

W. PECK,

Changes that I have observed in the Animal before any particular Alteration of the Weather.

1. When the leech lies motionless at the bottom of the glass, and is frequently in a spiral form, the weather in summer will be serene and beautiful: the same denotes clear frosty weather in winter.

2. If it creeps up to the top of its lodging, it will rain within twenty-four hours in summer, and snow in winter.

3. When the leech gallops through its limpid habitation with swiftness, it denotes wind, and seldom rests until it blows hard.

4. When the leech lodges almost constantly out of the water, and discovers uncommon uneasiness in violent throes and convulsive-like motions, a storm of thunder and rain will succeed.

Method of keeping Leeches.

1. Put a few into an eight-ounce phial two-thirds full of spring water, with some fine sand or moss at the bottom. As the leeches have no other evacuation but through the pores of the skin, which passes from them in perspirable matter, and adheres to the body in the state of slime, which, if not timely removed, prevents these evacuations, and causes the death of the worm; the use of sand, or moss, is that it may rub the slime off its body, which afterwards floats in the water. Over the top of the phial tie a piece of leather pricked full of holes to admit air.

2. The water must be changed once a week: spring
water

water is the best. Sometimes it is necessary, when there is a great change of temperature between the water and that contained in the phial, only to put half or two-thirds of the fresh to the other. Leeches should be kept in a cool situation in summer, and a rather warm one in winter.

3. The leeches that have been used for bleeding should be kept in a separate phial till they appear perfectly well.

Directions for using Leeches in Bleeding.

1. It is necessary to clean the skin from any foreign matter * that may have been applied or adheres to it, with soap and water: afterwards rub it dry with a clean cloth, as liniments, &c. which are frequently applied in cases of bruises, or sprains, prevent them from taking hold, and if any do so, they die: any part where hair grows must be clean shaved, to prevent the hair from annoying them. These are precautions that are necessary.

2. When leeches are applied, the patient should be in as horizontal a position as possible. Then take a wine or any other glass large enough to give room for the quantity that it is wished to take hold at once, being much better than the fingers; it gives the worms free motion in their circumscribed limits, retains them in their proper place, and supports them from falling. The glass should be reclined on one side to admit a free access of air. The leeches should be chosen large, to answer their purposes the more effectually. When they seem sufficiently filled, a small portion of salt should be put to their mouths, which will cause them to fall off, being better than taking them with the fingers, as it bruises them.

Treatment of the Leeches after they are satiated with Blood.

Place the leech on a clean plate; take a little common salt rubbed fine, about the size of a pinch of snuff, and place it in contact with the mouth of the worm; it will remain a short time in a state of torpor, after which it will disgorge part of the blood: a little more salt may then be placed near its mouth, repeating it until it is all disgorged, taking care that no part of the salt touch any other part of its body, which blisters, and is frequently the death of the leech. When the worm returns to its natural size, it may then be put into a bason of water: if it has received no injury it will frisk about and appear lively, if sickly it will sink to the bottom: should this be the case, place it in a separate

* Such as the *linimentum saponis, solutio ammoniac volatilis, &c.*

phial till well. Every leech should have a clean plate to disgorge itself on.

These observations have occurred in practice ; and I am convinced that if they are strictly attended to, the mortality amongst leeches will be much lessened.

N. B. Those who wish to use a leech as a weather-glass should choose one that has not been used for bleeding ; for after they have been used they are frequently sickly, and will bury themselves in the sand for days together.

LIII. *On Broom Flax.*

To Mr. Tilloch.

Chesnut Walk, Walthamstow,
November 23, 1809.

SIR, **T**HE inclosed specimens of the refuse and very worst of the flax of broom speak for themselves.

To procure the flax of broom it is only necessary to steep the twigs, or former year's branches (and the most vigorous shoots are the best) for two or three weeks, more or less according to the heat of the season, in stagnant water ; or to boil them for about an hour in water. This done, the flax comes freely from the twigs ; and, where there is not machinery for the purpose, may be easily peeled or stripped off, by children or others, at any time when not quite dry, in the same way as hemp is peeled from the stalks. And what adds to the value of the discovery, if it may be so called, is, that on being cleared of the flax, and steeped for some time in boiling water, the twigs, or wood, become tough and beautifully white, and are worth, at a medium, from a shilling to eighteenpence per pound for making carpet brooms, &c.

When stripped from the twigs, the flax requires only to be well washed in cold water, then wrung and shaken well, and hung out to dry, previously to its being sent off to the paper manufacturers, &c. Professor Davy has bleached some of it for me ; and I have seen it spun.

The discovery and my experiments respecting broom flax have occupied the greater part of my leisure hours for several months past, and have been attended both with trouble and expense ; yet if the poor on the north side of the Tweed, and in Ireland, (independent of those belonging to such of the 9700 parishes in England as have broom in them,) are bettered by the discovery, it will give me more real satisfaction

faction than if I had taken out a patent and made a fortune by it. With regard to any reward for my experiments and trouble I am not sanguine: if it be said of me that I have been useful to my country, and have not lived in vain, I shall be satisfied.

As the idea of flax being furnished by broom is new, I have sent specimens of the flax to the Royal Society, to the Board of Agriculture, to the Society of Arts, to the British Museum, &c.; and I have sent you the inclosed specimens, that you may inform the public in what manner the poor, in counties where broom is plentiful, if they want employment, may find one, easy and by no means unprofitable.

I am, &c.

JAMES HALL.

P.S. The fibres of all kinds of mallows I find are uncommonly beautiful; particularly the *malva sylvestris*. They are finer and prettier than camel's hair, which they somewhat resemble; and there is no difficulty in procuring them.

LIV. *On Respiration.* By WILLIAM ALLEN, Esq., F.R.S. and WILLIAM HASLEDINE PEPYS, Esq., F.R.S.*

ONE of the most prominent features in our last communication was the evolution of a considerable quantity of azote, when oxygen gas nearly pure was respired; and although a considerable part of this azote must undoubtedly be attributed to the residual gas in the lungs, after the most forcible attempt at expiration, yet the fact seemed to demand still further investigation, it appearing of consequence to ascertain whether the increase of azote was uniform throughout the latter stages of the experiment, or *solely* confined to the earlier periods.

By adverting to our former paper, it will be found, that in an experiment where more than 3000 cubic inches of oxygen passed through the lungs in seven minutes and a quarter, 62 cubic inches of azote were found in the first 250 cubic inches expired, though the gas originally contained but 2.5 per cent., or only 6 cubic inches in this quantity; in the two next portions expired, consisting of 562 cubic inches, we found 56 cubic inches of azote, though this quantity of gas, before it was respired, contained only 14; these, first portions, were given off in about

* From Philosophical Transactions, Part II., for 1809.

two minutes, and contained nearly 100 cubic inches of azote more than could be accounted for in the oxygen employed; hence it is plain, that a large proportion of the increase is evolved in the first periods of the process.

Our attention was particularly directed to this point in the following experiment. The oxygen, procured as usual from hyperoxygenized muriate of potash, was found to contain four per cent. of azote; the experiment was conducted in the same manner as the preceding ones, except that the tubes of the gasometers were filled with oxygen, and the gas was not merely passed *once* through the lungs, but breathed backwards and forwards in order to prolong the duration of the experiment, which began and ended with a forcible expiration. Portions of the respired gas were preserved for examination from each of the gasometers, in the following order:

No.	No.
1. 244	7. 254
2. 294	8. 288
3. 282	9. 252
4. 266	10. 168
5. 230	—
6. 266	2544

The portion of oxygen remaining in the water gasometer of the original quantity, not employed in the experiment, was found upon trial to contain four per cent. of azote, as before.

Summary of the Experiment.

Bar.	Therm.	Cub. Inches of Oxygen inspired.	Cub. Inches of Gas ex- pired.	Defi- ciency.	Time.
29.9	51	2668	2544	124	13 minutes:

here the deficiency was greater than we had ever remarked before; but on passing an equal quantity of common air from the water gasometer, and registering it in the mercurial ones, we were satisfied that the apparatus was quite perfect. It is, however, to be considered, that the respiration in this case was not natural, and that some small degree of force was required when the inspirations and expirations were made in the mercurial gasometers, which renders this experiment rather different from those which had preceded it; and it appears to us probable, that a portion of air was forced into the extremities of the bronchia, which could not be suddenly expelled by the strongest attempts at expiration. Hence also, perhaps, the constant though smaller deficiency, even when the air was only once passed

passed through the lungs; but when the process is continued for a much longer time, it is probable that the vessels recover their tone, and are able to expel nearly the whole of the volume admitted.

The air expired in the present instance being examined in the manner described in our last paper, we found that 100 parts from each of the gasometers contained the following proportions:

No. 1.	10	carbonic acid
	21	azote
	69	oxygen
	<hr/>	
	100	
	<hr/>	
No. 2.	10	carbonic acid
	11	azote
	79	oxygen
	<hr/>	
	100	
	<hr/>	
No. 3.	10	carbonic acid
	8.5	azote
	81.5	oxygen
	<hr/>	
	100	
	<hr/>	
No. 4.	10	carbonic acid
	7.75	azote
	82.25	oxygen
	<hr/>	
	100	
	<hr/>	
No. 5.	10	carbonic acid
	7	azote
	83	oxygen
	<hr/>	
	100	
	<hr/>	
No. 6 to 10 mixed	10.5	carbonic acid
	5.5	azote
	84	oxygen
	<hr/>	
	100	
	<hr/>	

We shall first calculate the total quantity of azote existing in the gas before the experiment, and afterwards estimate what

what was produced in the different periods during the first half of the experiment.

Calculation for Azote.

2668 cubic inches of oxygen were employed containing four per cent. azote: then

$$100 : 4 :: 2668 : 106.72$$

the total quantity of azote in the gas consumed, was 106.72 cubic inches.

Azote found after the Experiments.

	Cubic Inches.		Azote found.
No. 1.	244	100 : 21 ::	244 : 51.24
2.	294	100 : 11 ::	294 : 32.34
3.	282	100 : 8.5 ::	282 : 23.97
4.	266	100 : 7.75 ::	266 : 20.61
5.	230	100 : 7 ::	230 : 16.10
6 to 10.	1228	100 : 5.5 ::	1228 : 67.54
			Total 211.80 cubic inches.

The whole azote, found after the experiment, was	- - -	211.80 cubic inches.
Azote detected by the same tests before the experiment only	-	106.72
		Increase of azote 105.08

Now, as the whole time was thirteen minutes, if we divide this by the number of gasometers filled, it will give us one minute eighteen seconds for each, and the following will be the periods in which the azote was evolved.

No.	Time.	Azote found.	Azote in the Oxygen.	Increase.
1.	1.18	51.24 less	9.76 equal to	41.48
2.	1.18	32.34 -	11.76 =	20.58
3.	1.18	23.97 -	11.28 =	12.69
4.	1.18	20.61 -	10.64 =	9.97
5.	1.18	16.10 -	9.20 =	6.90
6 to 10.	6.30	67.54 -	49.12 =	18.42
	13 min.	211.80	101.76*	110.04

Here the increase of azote appears rather greater, viz. 110

* The apparent deficiency here 4.96 arises from this circumstance, that the separate portions of oxygen here not having been ascertained, this calculation has been made with the corresponding but smaller portions of expired gas.

cubic inches, but the calculation in this case is made upon the gas expired; and, from the above statement, we may see that the evolution of azote goes on diminishing; we have sometimes even found, that towards the close of an experiment it has been almost reduced to nothing. The question now is, whether this increase of azote can be owing to the residual gas contained in the lungs at the beginning of the experiment, or whether a portion of oxygen is not actually exchanged for azote, when pure oxygen gas is respired.

Here it may be useful to compare the azote found in our former experiments on oxygen, with the present.

No.	Bar.	Therm.	Oxygen			Time.	Quantity		Inferred
			Gas inspired.	Gas expired.	Deficiency.		respired in a minute.	Azote evolved.	
1.		53	3260	3193	67	9 ^h 20 ^m	318	110	141
2.	30.3	70	3420	3362	58	7.25	461	177	225
3.	30.15	70	3180	3060	70	8.45	357	187	236
4.	29.9	51	2668	2544	124	13.	205	105	133

The greatest increase of azote was in the 2d and 3d experiments, when the thermometer was at 70°, which might materially influence the results: in the other cases, it was not higher than 53.

From the experiments of Goodwin, we might be inclined to admit the capacity of the lungs, inferred from the 1st and 4th experiments, as very possible; but it seems difficult to conceive that it can amount to 236 or 225 cubic inches; and yet this must be the case, unless a portion of azote is given off from the blood, or there is some process in nature by which it is capable of being produced from oxygen.

Having, by the kindness of our friend Henry Cline, jun., been furnished with the lungs of a stout man, about five feet ten inches high, taken from the body not long after death, and in a sound state, we proceeded to ascertain the quantity of air contained in this organ after the most complete expiration, as in death.

Henry Cline had judiciously taken the precaution to divide the trachea just below the crichoid cartilage, before he opened the thorax; he then inserted a tube with a brass stop-cock, which he tied firmly to the trachea, and attached an empty bladder to the other end. The cock was then turned, so as to communicate with the bladder, and on opening the thorax 31½ cubic inches of air were expelled into it. The weight of the lungs was four pounds one ounce. A very large glass jar being placed in a shallow tin vessel,

vessel, was filled to the brim with water, the lungs were then completely immersed, and the water which flowed over, and was the measure of their volume, weighed six pounds two ounces: we next cut a portion of the lungs into small pieces, under a large inverted glass of water, and attempted to squeeze the air from the cells; but although several cubic inches were thus procured, we were soon convinced that it was utterly impossible to arrive at our object by these means, as no force that we could use seemed capable of expelling the air from the cellular membrane, into which it escaped from the vesicles. We therefore took portions of the lungs, which weighed 2774 grains; the mass being put into a piece of new hair cloth, was subjected to the action of a powerful screw press, and the fluid was received in a vessel; after twice undergoing this operation, the mass weighed only 660 grains. Its specific gravity was very nearly that of water, viz. .930 water being 1.000: the fluid procured by the press was of the specific gravity of 1.019; this would make the specific gravity of the lungs .997, water being 1.000: hence it appears, that the substance of the lungs, and the contents of the blood-vessels together, are so near the specific gravity of water, that they may be fairly considered as the same.

Then, as the mass of the lungs was equal to 4 pounds of water, though 6.2 pounds of water were displaced by them, and as a pound of water occupies the space of 28.875 cubic inches, we have the following calculation:

lbs.	oz.	
6	2	water displaced by the lungs
4	1	weight of the lungs
—		

2 1, or 59.554 cubic inches of air in the lungs, to which
must be added 31.580 the volume of the air forced into the
bladder on opening the thorax.

91.134

and this gives us 91.134 cubic inches, as the air contained in the lungs of this person after death; and when we reflect that the air must have been under compression, when the lungs were immersed in water, some force being required to keep them down, and also that not less than 7 or 8 cubic inches must be contained in fauces, &c., we cannot estimate the whole at less than 100 cubic inches.

It is further to be noted, that these 100 cubic inches would occupy much more space in the temperature of the human body, than in the mean temperature in which the examination was made; and this difference would be nearly
8 cubic

8 cubic inches; the air left in the lungs, after complete expiration, would therefore be 108 cubic inches; but the mean of our experiments would make it 183.

Experiment 1.	141
2.	225
3.	286
4.	133
	4) 735
	183

We are then almost compelled to allow that when pure oxygen is respired, a portion of azote is given off from the blood.

We now resolved to perform a series of experiments upon some animal which lived wholly upon vegetable food, and made choice of the Guinea pig as one of the most manageable.

The apparatus consisted of our two large mercurial gasometers, which were made to communicate with a strong trough E, in the middle of which a small mahogany table D was made fast by a screw, for the purpose of supporting the animal under the bell-glass A; two holes were made through the table for the insertion of tubes to supply and take off the air, each of them communicated with one of the mercurial gasometers; the tube B delivered gas towards the upper part of the glass A, in order to bring the supply of fresh air near the head of the animal: the opening of the tube C was placed within half an inch of the table to convey off the respired air; the gasometer connected with this tube was made to communicate with a mercurial bath G, in which portions of the respired air were preserved for examination. Quicksilver being poured into the trough E, so as to rise to a level with the top of the mahogany stand, we placed a Guinea pig upon it, with the bell-glass over him, and as its edges were immersed in quicksilver, the animal was completely confined in atmospheric air: we found that his body occupied the space of 39 cubic inches, which deducted from the cubic contents of the glass A, left 55 cubic inches for the air confined with the pig, to which must be added 5 more for that contained in the tube C.

First Experiment with Atmospheric Air.

The pig was placed upon the stand, and the apparatus arranged as represented in the plate: 250 cubic inches of

atmospheric air were admitted into the mercurial gasometer communicating with B: the gasometer communicating with C was quite empty, the apparatus being tried was found perfectly air tight, and the whole quantity of air 310 cubic inches.

The cocks H and I being opened, gentle pressure was made upon the glass of gasometer B, so as to cause the air to pass through A, which consequently drove an equal portion through the tube C into the empty gasometer; a quarter of an hour was employed in passing the gas, which measured exactly 250 cubic inches in C, so that there was no alteration of volume; the cocks H and I were now closed, and the respired air being examined by the usual methods, 100 parts were found to contain

5 carbonic acid
16 oxygen
79 azote

100

As the air after the experiment had experienced no alteration of volume, and as it contained the same proportion of azote as atmospheric air, this substance had remained unaltered. But 15.50 cubic inches of oxygen had been converted into carbonic acid gas.

100 : 5 :: 310 : 15.50.

Summary of the Experiment.

Bar.	Therm.	Atmos. air inspired.	Gas after experiment.	Cub. inches of carb. acid.	Cub. in. of carb. acid per minute.	Time.
30°	43°	310	310	15.5	.62	25 min.

Experiment II. Atmospheric Air.

The experiment was repeated in exactly the same manner; the animal, except from confinement, appeared much at his ease all the time. The air after the experiment contained in 100 parts

5.5 carbonic acid
15.5 oxygen
79 azote

100

Here the proportions of azote were undisturbed, and 17.05 cubic inches of carbonic acid procured.

100 : 5.5 :: 310 : 17.05.

Summary

Summary of the Experiment.

Bar.	Therm.	Atmos. air inspired.	Air after Experiment.	Carb. acid found.	Carb. acid per minute.	Time.
29.66	38°	310	310	17.05	.68	25 min.

Experiment III. Atmospheric Air.

The apparatus being arranged as before, we kept the pig in the glass A for one hour, and during that time passed 1000 cubic inches of atmospheric air through it, which measured 1001 : portions of the respired gas had been preserved in the mercurial bath, and the usual trials made upon the mixture, which was found to contain 5 parts of carbonic acid in every 100, or 53 cubic inches in the whole quantity ; the azote was unaltered ; 100 : 5 :: 1060 : 53.

Summary of the Experiment.

Barom.	Therm.	Atmos. air before expt.	Air after expt.	Increase.	Carb. acid found.	Carb. acid per min.	Time.
29.8	56°	1060.	1061	1	53	.88	1 hr.

[To be continued.]

LV. Description of certain Inventions for the Improvement of Naval Architecture, for increasing the Comforts of Mariners, and for facilitating Naval Enterprises. By Messrs. R. TREVITHICK and R. DICKINSON.

THE inventions alluded to in the above title form the matter of a patent granted to Messrs. Trevithick and Dickinson. They are at the same time so novel, ingenious, and useful, that we are persuaded we shall confer a favour on many of our readers by giving some of the particulars detailed by the patentees in a prospectus which they have circulated among their friends.

I. A wrought-iron moveable Caisson with a Rudder, for Docking a Ship, while riding at her Moorings, in any Depth of Water, leaving her Keel dry in a few Hours, without removing her Stores or Masts.

“ This floating dock is made of wrought-iron, half an inch thick, 250 feet long, 54 feet wide, and 30 feet deep, and will weigh about 400 tons, with a flanch six feet wide on the top, for the workmen to stand upon, and also to strengthen the caisson.

“ The weight of this caisson, when immersed in water, is nearly 350 tons; but, for reasons mentioned below, it

is rendered nearly buoyant, being surrounded by an air receptacle capable of suspending the whole weight with great exactness, which is riveted to it in such a manner as also to strengthen the caisson, and support the principal shores from the ship.

“ This caisson draws nine feet water. When taken to the ship intended to be docked, the water is to be let into it at an opening or plug-hole at the bottom, and it is to be suffered to sink until the upper part is even with the surface of the water, the air receptacle still keeping it buoyant. A small quantity of air is then to be discharged by opening a plug-hole in the air receptacle, until a quantity of water is let in just sufficient to sink the caisson, which is to be then drawn under the ship's bottom. This being effected, the caisson (nearly buoyant) is then to be raised to the surface of the water by ropes made fast from the caisson to each quarter of the ship. A pump placed within the caisson, and worked by a steam-engine of 12-horse power, placed in a barge alongside, will empty it in three hours, and reduce the ship's draught of water eight feet; that is, from 26 to 18 feet; when she may be carried up into shoal water, the caisson floating with a draft of only 18 feet of water, while the ship she carries would have required 26 feet. She may then be carried into shoal water, if required, or alongside wharfs, or jetty-heads of the dock-yards.

“ The ship's sides and bottom tending to fall outwards, by its own weight, and the sides and bottom of the caisson tending to be forced inwards, by the external pressure of the water, it is obvious that by placing props or shores, between, both will be supported, while the ship will ride with all her stores on board and masts standing, nearly as easy as when floating in the water.

“ Should inconvenience be apprehended at any time from blowing weather, the caisson may be cast off, and let fall to the bottom, where it cannot be injured, and from whence it may be raised to the ship's bottom again at pleasure, with as little labour as weighing an anchor.

“ The upper part of this dock will be 12 feet above water when there is a first-rate ship in it; this is a sufficient height to prevent the sea breaking over.

“ By this means a ship may have her bottom examined, and be out again in six hours, without coming above the Nore, and without undergoing the tedious process of unshipping and re-shipping her stores, or waiting for spring-tides, or fair wind, to enable her to reach to, or return from,

from, dock, which, on an average, now requires three months, accompanied with an expense of nearly 10,000*l.* per month in wages, subsistence, &c. &c.

“ This plan may be practised in all countries, and must be particularly advantageous where there are no dry docks or flowing of tide.

“ Ships on many foreign stations when requiring to be docked are now obliged to be sent home, at a great expense of money and waste of time, others being sent to replace them. This may be avoided in future. Docks made in England may be sent out in pieces of five or six tons with the necessary rivets and bolts, and ready to be put together wherever they may be wanted.

“ A caisson capable of docking a first-rate ship will not cost above nineteen or twenty thousand pounds, (for merchantmen and smaller ships, the size and cost will be proportionably less,) and (judging from the duration of wrought-iron *salt-pans*) will last 20 years without repair. When worn out it may be broken up, and will sell for one-third of its original cost.

“ By adapting caissons to the local circumstances, ships of war and merchantmen with all their stores and cargoes on board, can be carried to wharfs and store-houses up rivers where the depth of water is not above one half the ship's draught: For example, in the river Clyde the ships may be carried to Glasgow, instead of being obliged to unload twenty miles lower down the river.”

II. *Improved System for Towing Ships, Floating Docks or Caissons.*

“ This subject, as connected with naval affairs, possesses much importance.

“ It will readily occur that there are many instances on record where objects of the first magnitude might have been gained by the help of an improved system of towing vessels, particularly when entering or leaving harbour. But although the system about to be explained is perfectly applicable to general purposes, it was chiefly with the view of rendering our floating dock complete in all its appendages, that we were induced to direct our attention to the subject.

“ With respect to the general application of the system of towing, it will occur, that an apparatus of this description ought to attend every naval expedition. It will of course be useful in towing ships into action in light winds, in bringing off disabled vessels, and also in propelling fire-

ships against wind and tide after the crew have abandoned them; while, by the same contrivance, the look-out ships of a squadron, or packet-boats, will be enabled to enter or leave harbour in spite of wind and tide. But as those interested in the adoption of such improvements need not be informed of their manifold advantages, we shall confine ourselves to a brief description of our towing apparatus.

“ The employment of steam-engines⁴ for this purpose has no novelty; but, however competent this agent in other respects, it has generally failed in this branch of its application, not from its own incompetency, but from a defect in the communication required between the power and the water upon which it is destined to act; and from not considering that a power insufficient to move a vessel with others, in tow, may be sufficient to move them alternately, that is to say, first the vessel containing the engine, and then, by the communicating rope, the vessels which the first-mentioned vessel has to move.

“ A steam-engine of fifty tons weight on board a barge, or ship, will tow with much greater power and effect, while only impelling a vessel forward by the action of the engine against the water, than a thousand men can do with sweeps. But if the same engine is applied to wind up a rope, made fast to buoys, anchors, or any other fixture, the power can be increased to any extent, at the expense of a loss of time merely equal to the effect gained.

“ Many of the naval harbours in England are so situated that it is a fair wind to go to sea with, when perhaps it blows directly into the harbour's mouth. By the placing of buoys, at about 400 yards distance from each other, this difficulty may be overcome: with an engine of the above description, men of war and transports might be towed out clear of the harbour in a short time.

“ This may be effected in the following simple manner:—The steam engine will drive itself in the barge to the first buoy, where it will be made fast, at the same time paying out about 400 yards of tow-rope, or less, as the case may require, one end being fast to the ship to be taken in tow, the other being fastened to a capstern, to be moved round by the power of the engine. This movement brings the ship up to the first buoy, where it is made fast, when the engine with the barge starts afresh to the next buoy, and so on until the ship or ships in tow arrive at the outer buoy. In situations where there are no buoys, anchors may be dropped, and speedily weighed again by means of the steam-engine;

engine ; but it is only in extreme cases this routine is necessary. Generally the power of the engine will be found quite sufficient.

[To be continued.]

LVI. *Notices respecting New Books.*

PART II. of the Philosophical Transactions for 1809 has made its appearance. The following are its contents :

10. On Platina and native Palladium from Brasil. By William Hyde Wollaston, M.D., Sec. R.S.—11. On a native Arseniate of Lead. By the Rev. William Gregor. Communicated by Charles Haichett, Esq., F.R.S.—12. An anatomical Account of the *Squalus maximus* (of Linnæus), which in the Structure of its Stomach forms an intermediate Link in the Gradation of Animals between the Whale Tribe and cartilaginous Fishes. By Everard Home, Esq., F.R.S.—13. On an Improvement in the Manner of dividing astronomical Instruments. By Henry Cavendish, Esq., F.R.S.—14. On a Method of examining the Divisions of astronomical Instruments. By the Rev. William Lax, A.M. F.R.S. Lowndes's Professor of Astronomy in the University of Cambridge. In a Letter to the Rev. Dr. Maskelyne, F.R.S., Astronomer Royal.—15. On the Identity of Columbium and Tantalum. By William Hyde Wollaston, M.D., Sec. R.S.—16. Description of a reflective Goniometer. By William Hyde Wollaston, M.D., Sec. R.S.—17. Continuation of Experiments for investigating the Cause of coloured concentric Rings, and other Appearances of a similar Nature. By William Herschel, LL.D. F.R.S.—18. An Account of a Calculus from the Human Bladder of uncommon Magnitude. By Sir James Earle, F.R.S.—19. On expectorated Matter. By George Pearson, M.D., F.R.S.—20. On the Attractions of homogeneous Ellipsoids. By James Ivory, A.M. Communicated by Henry Brougham, Esq. F.R.S.—21. Observations on Albumen, and some other Animal Fluids ; with Remarks on their Analysis by electro-chemical Decomposition. By Mr. William Brande, F.R.S. Communicated by the Society for the Improvement of Animal Chemistry.—22. Hints on the Subject of animal Secretions. By Everard Home, Esq., F.R.S. Communicated by the Society for the Improvement of Animal Chemistry.—23. On the comparative Influence of Male and Female Parents on their Offspring. By Thomas Andrew Knight, Esq., F.R.S. In a Letter to the Right

Hon. Sir Joseph Banks, Bart. K.B., P.R.S.—24. On the Effect of westerly Winds in raising the Level of the British Channel. In a Letter to the Right Hon. Sir Joseph Banks, Bart. K.B., P.R.S. By James Rennell, Esq., F.R.S.—25. On Respiration. By William Allen, Esq., F.R.S. and William Hasledine Pepys, Esq., F.R.S.—26. Experiments on Ammonia, and an Account of a new Method of analysing it, by Combustion with Oxygen and other Gases; in a Letter to Humphry Davy, Esq., Sec. R.S., &c., from William Henry, M.D., F.R.S., V.P. of the Lit. and Phil. Society, and Physician to the Infirmary, at Manchester.—27. New analytical Researches on the Nature of certain Bodies, being an Appendix to the Bakerian Lecture for 1808. By Humphry Davy, Esq., Sec. R.S., Prof. Chem. R.I.—Presents received by the Royal Society, from November 1808 to July 1809.—Index.

An Essay on the Torpidity of Animals has lately appeared from the pen of Henry Reeve, M.D., Member of the Royal College of Physicians of London, and Fellow of the Linnæan Society.

LVII. *Proceedings of Learned Societies.*

ROYAL SOCIETY.

THIS Society met on Thursday the 9th of November, the right hon. Sir Joseph Banks, president, in the chair. It was chiefly occupied in reading the minutes of the last meeting prior to the long vacation, and in receiving presents of both foreign and domestic publications on the sciences and arts.

Nov. 16.—Alexander Marsden, esq., vice-president, in the chair. The Croonian Lecture on muscular motion, by Dr. Wollaston, was read. Dr. W., perceiving that his remarks were rather unconnected to form a regular essay, divided his lecture into three parts; the first on the duration of muscular action. This he attempted to ascertain by pressing his finger on his ear, till it resembled the sound of carriages passing along a pavement of stones about four inches in diameter. These vibrations he found to vary according to the pressure from 15, which were the least, to 45, the most; but the general number he found to be 30 in a minute. He afterwards endeavoured to imitate the sound of carriages by rubbing two notched sticks against each other, and experienced nearly the same results. Some of his

his friends repeated these experiments with the like effect. The second part was on the cause of sea sickness, which the lecturer attributed to the pressure of blood upon the brain; and observed that the sickness was always most violent when the vessel pitched most, or rather at the moment when she descends from the wave on which she had been elevated. In this case respiration is difficult; but when effected, it assists the circulation, and gives relief to the sickness. The stomach he also found to be slightly deranged, probably from the same cause, or from the action of the system to resist the effects of the unnatural motion of the vessel. The third and last part illustrated the advantages of riding on horseback and in carriages, which enables the system to propel the blood from the heart. Dr. W. related a case of a gentleman, who, finding himself very ill, ordered his coachman to drive him to the residence of a fashionable physician, who fortunately happened not to be at home; he then resolved on driving to another, who also happened to be absent: by this time he had considerably recovered from his depression, and determined on going home, and taking the same exercise next day, which he did, and speedily recovered without any aid from drugs.

The reading of the Bakerian Lecture on some new electro-chemical researches on metallic bodies, and on the combinations of hydrogen, by Mr. Davy, commenced November 16, and was continued on the 23d, and the conclusion postponed to a future meeting.

Mr. Davy stated his objects in delivering this lecture, to be the elucidation of various important parts of chemistry by new experiments, and the communication of some new facts respecting metallic bodies, and their combinations intimately related to the general philosophical theory of the science. In the first section he discussed the various hypothetical notions that had been formed respecting the metals of the fixed alkalis, particularly those of MM. Gay-Lussac and Thenard, M. Curadau, and M. Ritter. He brought forward many experiments to prove that potassium and sodium, by combustion, produce merely dry potash and soda; and that they neither form water nor carbonic acid; and he establishes the fact, that the potash formed by the combustion of potassium in muriatic acid gas contains less water than that which is considered by M. Berthollet as the dry alkali. He showed that when potassium is made to act upon ammonia, it is the volatile alkali, and not the metal, which is decomposed, for the potassium can, under certain

certain circumstances, be recovered unaltered; and whenever a portion of it is converted into potash some nitrogen always disappears.—The discussion concerning the nature of nitrogen he reserved for the conclusion of the lecture. His general inference from the experiments in this section was, “that potassium and sodium can with no more propriety be considered as *compounds* than any of the anciently known metals, and that they belong to the same order of substances.”

In the course of his investigation Mr. Davy described a new and curious gas composed of tellurium and hydrogen, which is soluble in water, which combines with the alkalis, and has the characters of a weak acid: a new fact added to those already known concerning sulphuretted hydrogen, against the idea of oxygen being the acidifying principle.

SOCIETY OF ANTIQUARIES.

This Society met at the same time and on the same evening as the Royal Society. A curious paper by Doctor Willan, on “New Fire,” was read, detailing the process of igniting wood by friction, and the superstitious customs of the Northern nations in preserving such fire unextinguished; with many incidental particulars of ancient manners and customs connected with this ceremony. Some letters from Sir C. Cornwallis, when at the court of Spain as minister to James I., were also read; but they contained little that was either very novel or very interesting respecting the manners of that country. The ceremony of the bull-feasts has been often described, and is already sufficiently known.

LVIII. *Intelligence and Miscellaneous Articles.*

BOTANY.

To Mr. Tilloch.

SIR, HAVING lately had occasion, for a particular purpose, to ascertain the probable number of plants that have been described, it may perhaps save some of your botanical readers, who, like me, know of no other mode of satisfying their curiosity than by counting the number of species in the most complete enumeration published, the pain of undergoing a like tedious process, if I put on record in your excellent publication the result of my labour.

The

The method I adopted was to extend upon a sheet of paper the number of species of all the genera enumerated by Dr. Turton in his translation of Gmelin's edition of the *Systema Naturæ*, and then to add them together. I used this work as far as the class Gynandria, because it seems to contain all Willdenow's species, with some additions. Gynandria and Monœcia I extracted from Willdenow's first part of his fourth volume, which was not published when Dr. Turton's work came out: the remaining classes were taken from Dr. Turton. From this examination I found that in these works are described 2046 genera, and 19,803 species, of plants; of which 638 genera have but one species, 263 but two, 174 but three, and 124 but four.

I consider this enumeration, however, but as an approximation to the truth. Willdenow's work must be defective, and I conceive Gmelin to be particularly so in the Cryptogamia class. Probably we should not be far from the truth if we call the number of described plants 22,000. The first edition of Linnæus's *Species Plantarum* contained only 7,300 species.—I am, sir,

Your very humble servant,

Nov. 14, 1803.

BOTANICUS.

POISONOUS EFFECTS OF CHAMPIGNONS.

A family, consisting of the father, mother, and daughter, died last month in the commune of Portels, in France, from the effects of eating champignons, which they procured from an old woman who was in the regular habit of collecting them for sale. The old woman herself, although she had used a great quantity of the same kind of champignons as food for several meals, escaped all disagreeable effects. It was found, upon inquiry, that she was intoxicated with sour wine at all her meals, and the effect of vegetable acids in counteracting narcotic poisons is well known. It is somewhat singular that the persons who died, and the inhabitants of the place where they lived, concurred in assuring the medical attendants that they had repeatedly used the same species of mushrooms as food in former seasons, but without any bad effects. The French naturalists have suggested that the insalubrious state of the atmosphere during last autumn may have given the poisonous qualities to the champignons in question.

MEDICAL FUMIGATIONS.

The French journals lately received contain various reports from different parts of the continent on the subject of

of Guyton de Morveau's antiseptic process. In Poland the oxygenized muriatic acid fumigations were resorted to in the military hospitals with the greatest effect: not only were various putrid effluvia dispelled in this manner, but the vermin of all descriptions with which the patients were infested were extirpated. M. de Laborde, chief physician in the marine department at Antwerp, on the 18th of October 1808, communicates the following account to M. de Morveau:—"During the raging of the present epidemy, which suddenly attacked a great number of persons, we were under the necessity of bringing the patients from the galleys into the usual hospitals. In one hall, which was badly aired, and where numerous cases of dysentery and ataxic fevers corrupted the air, I had recourse to the oxygenized fumigations, and succeeded in preventing the contagion from spreading; the last-mentioned patients themselves were not even attacked. Finally, in a ward where there were forty or fifty severe cases of dysentery, a form under which several ataxic quotidian fevers are concealed, and which are very prevalent at this season of the year, a few fumigations were sufficient to banish the bad smell, and no disgust was occasioned." [The same process is adopted (in preference to Dr. Carmichael Smith's) on board the squadron in the Scheldt; it is also used in the various naval hospitals; and sometimes great advantages are derived by directing these fumigations on putrid, gangrenous, or atonic ulcers, by means of a funnel.]

REMEDY FOR TAPEWORM.

Common spirits of turpentine have been recently administered by several medical gentlemen of the metropolis, with great effect, in the cure of tapeworm. The doses given were in some cases so large as two ounces; but those of half an ounce at a time, repeated twice a day, were generally found to answer the purpose of expelling the whole, or at least the greater part of the animal, at one discharge. The vehicle in which the turpentine was administered was generally honey.

To Mr. Tilloch.

SIR,—It is a fact known to most good housewives, and should be known to all, that if they begin to grate a nutmeg from the stalk end it will prove hollow throughout, whereas if the same nutmeg had been grated from the other end it would have proved solid and sound to the last. The reason of this appears to be, that the centre of a nutmeg consists

consists of a number of fibres issuing from the stalk, and its continuation through the centre of the fruit, the other ends of which fibres, though closely surrounded and pressed by the fruit, do not adhere to it; the consequence is, that when the stalk is grated away, those fibres having lost their hold, they insensibly drop out, and the nutmeg appears hollow; and as more of the stalk is grated away, others of them drop out in succession, and the hollow continues through the whole nut; whereas by beginning to grate at the other end, the fibres above mentioned are grated off at their core end with the surrounding fruit, and they do not drop out and cause a hole. The want of knowing this has caused many excellent nutmegs to be condemned as damaged fruit, and others, of perhaps less value, to be commended, according as accident or caprice caused them to be grated from the stalk, or top end. And here I beg to mention, that, the oil of nutmegs being of great value, it has often been extracted from the nuts which are exposed to sale, whereby they are rendered of very little value; and the way to know good nutmegs is to force a pin into them, when, if good, however dry they may appear, the oil will be seen to ooze out all round the pin, by the compression occasioned in the surrounding parts by its being forced in.

F.

To Mr. Tilloch.

SIR,—Having lately, sometimes, had occasion to walk on different parts of the banks of the Thames when the tide was full, I observed objects much better on the other side than when it was ebb; and that cattle, houses, trees, &c. in the meadows, as well as the meadows themselves, that did not appear at all when the tide was ebb, seemed, when it was full, to be raised up very considerably. Has any of your correspondents observed this with regard to the Thames, or any other river, where the meadows behind the banks are in many parts lower than the surface of the river when the tide is full? And if so, could they explain the physical cause, or principle in optics, on which it depends?

I am, sir, yours, &c.

157, St. Martin's Lane,
Sept. 12, 1809.

JAMES HALL.

VOLATILIZED SILEX.

M. Vauquelin has lately directed his attention to the white filamentous substance found in the cavities of the fluxed matter which is attached to the sides of high furnaces:

naces: the following is the account given of this phenomenon by M. Vauquelin:

“ In melting iron ores there are frequently portions of the ore which, when they begin to assume the character of iron, are fixed before the moment of flowing, and consequently remain attached to the sides of the furnace. In these pieces of iron, cavities are found which are filled with a white filamentous substance like flexible amianthus.

“ Several metallurgists have noticed this substance, and it has been uniformly regarded as an oxide of zinc; but as I boiled it in various acids, which had no action on it, I thought myself warranted in concluding that there was not an atom of zinc present. The following experiment was therefore made with a view to ascertain the real nature of the substances in question:

“ Having heated this substance with three parts of caustic potash in a silver crucible, it was perfectly fused, and the mass that resulted was entirely dissolved by water.

“ This solution, when supersaturated with dilute muriatic acid, did not become turbid; but on evaporation it was transformed into a white and transparent jelly, which never happens with zinc.

“ The matter was perfectly desiccated, and the residue treated with water, when I obtained a white powder which presented all the characters of pure silix: in the liquor from which I obtained it, I found nothing else, not even oxide of iron. How does it happen that silix, which is always mixed, either in iron ores or in fluxes, with alumine and lime, is separated from these earths in a state of purity so perfect that no foreign matter is to be found?

“ The filamentous, and, as it were, crystallized state of the silix shows that it had been reduced into vapours by the violence of the fire, and afterwards gently condensed in the cooler parts of the furnace.

“ This experiment would seem to prove, not only that silix is volatile at a certain temperature, but also that it is more so than alumine or lime; unless we suppose these last to have been carried up much higher in the furnace; which is not very probable.”

LIST OF PATENTS FOR NEW INVENTIONS.

To Joseph Bramah, of Pimlico, engineer, for certain improvements in the constructing and making wheels for all kinds of carriages; and also a new method of locking or sliding the wheels of carriages when passing down steep declining hills.—November 2, 1809.

To

To John Isaac Hawkins, of Titchfield Street, machinist, for a certain instrument, machine, or manufacture, applicable in mechanics as a balance or equipoise.—Nov. 2.

To John Barton, of Argyle Street, Westminster, gent., for his improved lamp of a new construction, acting upon the natural unerring principle of the difference of gravity between two fluids, which produces a constant supply of oil or other combustible fluid to feed the wick or burner thereof fountain in a perpendicular direction, from a reservoir beneath the flame, having the quality of burning or consuming the whole of the oil or other combustible fluid applied thereto.—Nov. 2.

To David Meade Randolph, a citizen of Virginia, in the United States of America, but now residing in Warwick Court, Holborn, merchant, for certain improvements in the construction of wheeled carriages of every description.—Nov. 6.

To Edward Griffith, of Birmingham, optician, for his new invented air-tight agitable lamp.—Nov. 9.

To James Hall, of Newbold Astbury, in the county of Chester, bookbinder, for a method of making and manufacturing shives, or shivers, and pulley wheels of every description, and various other articles, from certain materials or composition of earths and minerals, which render the said articles more durable than such as are made in wood or metal.—Nov. 14.

To Robert Wass, of Sheffield, cutler, for certain improvements in the construction of hafts or handles for razors.—Nov. 21.

To John Cragg, of Liverpool, esq., for certain improvements in the casting of iron roofs for houses, warehouses, and other buildings, and in covering them with slate.—Nov. 21.

To John Towill Ruff, of Basinghall Street, London, John Tretton, of St. Andrew's Hill, and John Webb, of Clapton, in the county of Middlesex, for their various improvements in the construction of machines for making cards for carding wool, cotton, flax, silk, and all substances capable of being carded.—Nov. 21.

METEOROLOGICAL TABLE,
 BY MR. CAREY, OF THE STRAND,
 For November 1809.

Days of the Month.	Thermometer.			Height of the Barom. Inches.	Degrees of Dryness by Leslie's Hygrometer.	Weather.
	8 o'Clock, Morning.	Noon.	11 o'Clock, Night.			
Oct. 27	50°	56°	51°	30·28	16	Foggy
28	47	52	48	·28	14	Foggy
29	46	49	48	·25	6	Foggy
30	49	52	49	·16	3	Foggy
31	46	52	44	·02	10	Fair
Nov. 1	46	51	44	·11	7	Cloudy
2	45	50	45	·20	29	Cloudy
3	39	48	44	·08	10	Showery
4	45	45	42	29·75	0	Rain
5	42	43	40	·84	0	Rain
6	40	44	40	·84	10	Fair
7	41	49	41	30·10	15	Fair
8	40	45	40	·40	5	Fair
9	44	49	46	·38	12	Cloudy
10	46	50	42	·30	10	Cloudy
11	42	43	43	·09	7	Cloudy
12	43	44	42	29·85	6	Cloudy
13	41	47	40	·75	7	Cloudy
14	35	45	38	·62	5	Cloudy, with rain at night
15	35	36	31	·65	15	Fair
16	29	35	31	·69	10	Fair
17	37	43	50	·45	30	Stormy
18	27	37	31	·72	10	Storms of snow
19	29	34	30	30·28	15	Fair
20	24	34	34	·38	15	Fair
21	37	40	31	·28	10	Fair
22	37	49	47	·05	12	Fair
23	39	48	46	29·95	5	Showery
24	40	44	47	·10	0	Rain
25	40	42	40	·65	10	Fair
26	40	45	35	·11	15	Fair

N. B. The Barometer's height is taken at one o'clock.

LIX. *Description of a Rotative Steam Engine, the Piston of which makes a complete Revolution at a Distance from the revolving Axis. Invented by Mr. SAMUEL CLEGG, of Manchester.*

MANY attempts have been made to produce a rotative motion by means of steam, without deriving it from, or making use of, the rectilinear motion of the piston in the common or reciprocating engine. For this end steam wheels and other contrivances have been resorted to, but hitherto with little effect, owing to loss of steam, or to an increase of friction produced by the means employed to prevent this waste. Still a rotative steam engine appeared to promise so many advantages, could it be well accomplished, that some engineers continued to apply their thoughts to the subject, and Mr. Clegg announces that he has succeeded in producing a simple and effective engine of this kind, for which he has obtained a patent. This engine has no outward movements except the revolving shaft, which occupies the centre and works through a stuffing box in a cistern of water *M*; and which being the only opening into the engine prevents the entrance of all air excepting what is contained in the water used for injection. The steam pipe is at *P*, and the air pump is within the condensing vessel. The following is a description of the engine: See plates XIII and XIV.

Fig. 1 is the underside of a circular piece of cast iron, and of a diameter and thickness proportioned to the size of the engine. *I* is the common centre of the different circles shown on this piece. With any convenient radius less than that of *AA* describe the circle *CC*, and within the latter the circles *DD* and *EE*—the radius of the latter being the least of those now named. From the uses of these parts, which will be immediately described, an idea of their relative dimensions will readily be inferred.

Let that part of the surface *AB*, *AB* which is contained between the circles *A* and *C* be plain. Between the circles *C* and *D* sink a circular groove *CD* of any given depth; and between the circles *D* and *E* let another circular groove be cut of the breadth *DE*, and of any given depth less than that of the groove *CD*. Let the remaining part of the surface *AB*, namely, that included between *E* and *B*, be cut down to any depth less than the depth of the groove *DE*.

Into the groove *CD* let such a number of segments of a

circle be fitted as shall form a complete circle, excepting the space LL, which is occupied by adjusting screws, or springs to keep the segments close together. The segments are the breadth (or nearly) of the groove CD, and of a depth less than the depth of the groove CD. Those sides of them which apply to each other are to be ground together plain, and air-tight if possible. Their under surfaces, which are shown in fig. 1., are to be flat, so that the whole may form one complete plain surface, excepting the space before mentioned, which is taken up by adjusting screws or springs LL, which screws or springs are placed so far below the surface as to let a roller pass by them, which will be mentioned hereafter.

Figs. 2 and 5 represent vertical sections of the plate and grooves of fig. 1, resting upon a circular chamber or hollow space YY, to which chamber the said plate forms a light covering, excepting that space occupied by the springs or screws LL as before mentioned.

I, the centre of all the grooves and circles before described, is also the centre of the shaft. On the shaft I is fastened a plate or coupling ZZ, in which is inserted a bar F. This bar may be of any given breadth, but in depth must be less than the depth to which the circle EB was cut down below the surface AB. To this bar is attached a wheel or roller G, shown in fig. 3 upon a larger scale. The manner in which it is attached to the bar F is also there seen, and it is so attached to it that the top of the wheel or roller G shall always be higher than the top of the bar F. The wheel G being attached to the bar F will, when the bar is made to revolve, describe a circular path HHH along the plain surface of the segments before described. Let that portion of the plain surface of each segment which answers to the path of the roller G be rounded off, in such a manner as to make that portion of the surface an arc of a circle, the convex circumference of which is presented to the roller G. In fig. 3, at II is shown a perpendicular view of one of the segments, rounded off in the manner described, and presenting its convex circumference to the roller G. There may likewise be another roller attached to the bar behind it, to lower down the segments in the same manner in which they are raised by the first roller. Now it is obvious, all the said segments being in their places in the groove CD fig. 1, that the roller G, in performing a revolution round the centre I, must travel along a series of convex arcs of circles equal in number to the number of segments in the groove CD. The groove DE

is

is in fact a recess in the deeper groove CD, and may, if necessary, be filled with hemp and tallow, or any other material which may answer the purpose intended.

It must be remembered that fig. 1 is a view of the underside of this machinery. Figs. 2 and 5 are sections of it, supposed to be in its proper position resting as a cover to the circular chamber YY, and the segments resting upon a flat facing OO. Each segment projects over the facing OO on both sides; their projection on one side completes the cover over the hollow chamber, and the other is the rounded surface for the roller to lift them.

The facing OO is exactly, or as nearly as can be, level with the underside of the plate AB, AB, when the plate is on its place, as represented in fig. 2; so that, when the segments are all in their places, they complete the semi-circular chamber, and fit so close on their seats and in the groove, that were the chamber to be filled with any elastic fluid, they would prevent its escape (or nearly), excepting where the space is left for the springs or adjusting screws.

The use of these segments, which are what the patentee claims as his invention, is as follows: Conceive a door or valve to be fitted in the hollow chamber at Q, and a piston R, likewise fitted in the chamber so as to move round in it, and the bar F made fast to the piston, on the side and in the manner represented in fig. 1: then, if an elastic fluid, of sufficient strength, enters the chamber at N, it will press equally against the door or valve and the piston; but the door or valve being immovable, and the piston moveable, the piston will be propelled forward in the circular chamber by the elastic fluid. The bar F being fastened to the piston, and the roller G to the bar F in the manner represented in fig. 3, and the roller being in motion with the bar and piston, the roller will lift the segments in succession, as it comes in contact with them. The segments before the bar, being by this means lifted, allow the bar to pass, and the operation being the same in all, the bar and piston make a complete revolution. Each segment, as soon as the bar leaves it, falls down by its own gravity, or by springs, or any other contrivance, so that the opening which has been made for the bar to pass is closed before the elastic fluid reaches it; the elastic fluid being kept from the opening by the inner breadth of the piston exceeding the outer diameter of each segment. The door or valve is lifted out of the way of the piston, when the piston comes in contact with it, into the opening in the plate at N, a re-

cess being made in that segment which is opposite the door for that purpose; during which time the elastic fluid is shut out; but it enters again when the door returns to its seat, and thus the operation continues.

The preceding particulars are drawn from Mr. Clegg's specification of his invention. For the following, by which we are enabled to make our readers acquainted with all the parts of a steam engine on this construction, but which being, in some respects, common to all steam engines, were not specified, we are indebted to the patentee, who, on being asked, communicated them with the greatest readiness, and also the drawings from which the engravings have been made.

The exterior of the engine may have the appearance of a low pillar, an altar, a vase, or any suitable form that fancy may direct.

"In fig. 2, *c* is the condensing vessel, *a* the air pump, *b* the air pump bucket, *d* the hot water cistern, *e* the clack, *ff*, the inclined plane for working the air-pump bucket, is fastened on the shaft, and consequently revolves with it. To the air-pump bucket is attached a hollow tube through which the shaft goes. To this tube is fastened a cross bar, at each end of which is a roller *r*, resting upon the inclined plane: of course when the plane revolves the bucket rises and falls. The plane is divided into two different angles so as to make it more acute when the bucket rises, but nearly an angle of 45° where the bucket descends, as represented in the drawing.

"Fig. 4 is a view of the engine complete when at work.

"Fig. 5, a section of the principal part of the engine upon a larger scale, where the same letters employed in describing the smaller section mark the same parts. The injection enters the groove above the blocks, and keeps about three inches of water upon them. The injection then enters the condenser, out of the groove as seen at X. Each segment or block *K* is of sufficient weight to resist the pressure against that part of their under surface which is over the semi-circular chamber, and will generally be about 5-eighths of an inch. The blocks may likewise be lifted exactly in their centre of gravity by means of a lever in the upper part of the groove, and worked by a roller or small inclined plane fastened to the shaft, as represented by the dotted lines in fig. 5; and as it is not necessary for the blocks to rise more than half an inch or 5-eighths, the motion will be very easy; and whatever descending power the blocks have,

have, they will propel the bar forwards proportioned to their weight and the space through which they move, so that there is only the friction of the blocks to overcome. Supposing the pressure upon the piston to be 800lb., the weight of all the blocks will be about 500lb. for such a sized piston, and will seldom exceed more for the largest engines, as the space for the bar to pass will be nearly the same in all, the strength of the bar depending upon its breadth, not on its thickness: thus 800lb. will move through the space of 16 feet, whilst 500lb. goes through the space of half an inch: then, if the descending of the blocks is taken into consideration as before described, the friction of the blocks will make no sensible difference to the progress of the piston.

“The lid M being the only opening into the engine and the only stuffing box, and that covered with water, no air can enter but what is contained in the water used for injection.

“A very small fly is requisite, as the momentum is always in one direction, and that may be at any convenient distance, as circumstances may require.”

LX. *New analytical Researches on the Nature of certain Bodies, being an Appendix to the Bakerian Lecture for 1808. By HUMPHRY DAVY, Esq. Sec. R. S., Prof. Chem. R. I.*

[Concluded from p. 347.]

II. *Further Inquiries respecting Sulphur and Phosphorus.*

I HAVE stated, in the last Bakerian Lecture, that hydrogen is produced from sulphur and phosphorus in such quantities, by Voltaic electricity, that it cannot well be considered as an accidental ingredient in these bodies. I have likewise stated, that when potassium is made to act upon them, the sulphurets and phosphurets evolve less hydrogen in the form of compound inflammable gas by the action of an acid, than the same quantity of potassium in an uncombined state, and from this circumstance I have ventured to infer, that they may contain oxygen.

On the idea that sulphur and phosphorus are deprived of some of their oxygen by potassium, it would follow, that when the compounds formed in this experiment are decomposed, these substances ought to be found in a new state; deoxygenated, as far as is compatible with their existence in contact with water.

With the view of examining the nature of the substances, separated by the action of muriatic acid upon the sulphurets and phosphurets of potassium, I combined a few grains of sulphur and phosphorus with one-fourth of their weight of potassium, and exposed the compounds to the action of a strong solution of muriatic acid. As in the former cases, less inflammable gas was produced than would have been afforded by equal quantities of the uncombined potassium, and considerable quantities of solid matter separated from both compounds, which, after being washed, were collected in a filter.

The substance which separated from the sulphuret was of a dark gray colour*, and was harsh to the touch; it had no taste, and at common temperatures no smell; but when heated, it emitted the peculiar odour of sulphur. Its specific gravity was rather less than that of sulphur. It softened at a low heat, so as to be moulded like wax between the fingers. It was a non-conductor of electricity. When heated upon a surface of glass, it soon fused, entered into ebullition, took fire, and burnt with the same light-blue flame as sulphur. A small particle of it, made to combine with silver, presented the same phænomena as sulphur.

The substance from the phosphuret was of an amber colour, and opaque. It could not be examined in the air, in the form in which it was collected (that of a loose powder); for as soon as it was wiped dry it took fire, and burnt in the same manner as phosphorus; when melted under naphtha, it was found to differ from phosphorus, in being much deeper coloured, perfectly opaque, and very brittle. Its fusibility was nearly the same, and, like common phosphorus, it was perfectly non-conducting.

In experiments upon the union of potassium with sulphur and phosphorus the heat is so intense, that when larger quantities than a few grains are used, the glass tubes are uniformly fused or broken in pieces, and in consequence I have not been able to operate upon such a scale, as to make an accurate examination of the substances just described, and to determine the quantity of oxygen they absorb in being converted into acid. Metallic vessels of course cannot be employed; but I intend to try tubes of porcelain, in a further investigation of the subject.

It is evident that the sulphur and phosphorus, separated in these processes, are not in their common state; and the phænomena would certainly incline one to believe that they

* Possibly this colour may have been produced by the decomposition of a film of soap of naphtha adhering to the potassium.

are less oxygenated. It may, I know, be said, that it is possible that they are merely combined with more hydrogen, and that the sulphur in this state is analogous to the hydrogenated sulphur of Berthollet, and to the alcohol of sulphur of Lempadius.

But when I decomposed dry sulphuret of potash by muriatic acid, of the same kind as had been used for decomposing the sulphuret of potassium, the substance produced seemed to be merely in that form, in which, according to the able researches of Dr. Thomson, it is combined with water; and notwithstanding the ingenious experiments of M. A. Berthollet and M. Robiquet*, the nature of the substance produced during the passage of sulphur over ignited charcoal is far from being fully ascertained. In a series of experiments, which my brother Mr. John Davy had the goodness to undertake, at my request, in the laboratory of the Royal Institution, on the action of sulphur on charcoal, the products were found to be very different, according as the charcoal employed differed in its nature. In an instance, in which imperfectly made charcoal was employed, the liquor that passed over left by combustion a residuum that had all the properties of carbonaceous matter; which agrees with the observations of MM. Desormes and Clement; but when the charcoal had been well burnt, there was no such residuum produced. It was found, that the same charcoal might be employed in a number of processes till it was nearly entirely consumed, and that the sulphur, not rendered liquid, might be used for several operations. In all cases mixtures of † sulphuretted hydrogen gas and hydrocarbonate were evolved.

I particularly examined a specimen of the liquor which had been obtained in the last process from charcoal that had been often used. It was a non-conductor of electricity, and, when the Voltaic spark was taken in it, did not evolve gas with more rapidity than sulphur; and this gas proved to be sulphuretted hydrogen.

Supposing the liquor to contain hydrogen in considerable quantities, I conceived that it must be decomposed by oxy-muriatic acid; but it merely absorbed this substance, depositing crystals of common sulphur, and becoming a fluid similar to the sulphuretted muriatic acid; though when

* *Annales de Chimie*, 1807, page 144, 148.

† Five measures of the mixed gas, agitated with solution of potash, left a residuum of 3.5. These were detonated with 5.5 of oxygen; the whole diminution was to 6, of this residuum 2.5 appeared to be carbonic acid.

water was introduced, hydrated sulphur was instantly formed, and muriatic acid gas evolved.

From the quantity of carbonic acid formed by the combustion of the carburetted inflammable gas, produced in the operation of the action of well-burnt charcoal upon sulphur, it may be conceived to contain oxygen. This circumstance, and the fact that no hydrate of sulphur or muriatic acid gas is formed by the operation of oxymuriatic acid upon the liquor, but common sulphur precipitated; are in favour of the opinion, that the sulphur in this liquor contains less oxygen than in its common state. This idea has likewise occurred to Dr. Marcet, who is engaged in some experiments on the subject, and from whose skill and accuracy further elucidations of it may be expected.

III. *Further Inquiries respecting carbonaceous Matter.*

On the idea which I have stated, page 73*, that the diamond may consist of the carbonaceous matter combined with a little oxygen, I exposed charcoal intensely ignited, by Voltaic electricity †, to nitrogen, conceiving it possible that if this body was an oxide, containing oxygen very intimately combined, it might part with it in small proportions to carbonaceous matter, and give an important result.

The charcoal, which had been made with great care, was preserved for a quarter of an hour in a state of ignition, in which platina instantly fused. It did not appear to change in its visible properties; but a small quantity of black sublimate, which proved to be nothing more than finely-divided carbonaceous matter, collected in an arborescent state upon the platina wire to which the charcoal was attached. The gas had increased in volume one-sixth; but this was owing to the evolution of carburetted inflammable gas from the charcoal; the nitrogen was unchanged in quantity, and, as far as my examination could go, in quality. The points of the charcoal where the heat had been intense, were rather harder than before the experiment.

I have mentioned, page 102 ‡, that charcoal, even when strongly ignited, is incapable of decomposing corrosive sublimate. When charcoal, in a state of ignition, is brought in contact with oxymuriatic acid gas, the combustion instantly ceases. I electrified two pieces of charcoal in a globe

* Page 112 of this volume.

† The apparatus was the same as that referred to page 13. The power employed was that of the battery of 500 belonging to the Royal Institution.

‡ Page 189 of this volume.

filled with oxymuriatic acid gas, which had been introduced after exhaustion of the globe. They were preserved, for nearly an hour, in intense ignition, by the same means that had been employed in the experiment on nitrogen. At first, white fumes arose, probably principally from the formation of common muriatic acid gas, by the action of the hydrogen of the charcoal upon the oxymuriatic acid, and the combination of the gas so produced, with aqueous vapour in the globe; but this effect soon ceased. At the end of the process, the oxymuriatic acid gas was found unaltered in its properties, and copper leaf burnt in it with a vivid light. The charcoal did not perceptibly differ from the charcoal that had been exposed to nitrogen. My view in making this experiment, was to ascertain whether some new combination of carbonaceous matter with oxygen might not be formed in the process, and I hoped likewise to be able to free charcoal entirely from combined hydrogen, and from alkaline and earthy matter, supposing they existed in it, not fully combined with oxygen. That hydrogen must have separated in the experiment, it is not possible to doubt; and on evaporating the deposit on the sides of the globe, which was in very minute quantity, and acted like concentrated muriatic acid, it left a perceptible saline residuum*.

IV. *Further Inquiries respecting Muriatic Acid.*

The experiments on muriatic acid, which I have already had the honour of laying before the Society, show that the ideas which had been formerly entertained respecting the difference between the muriatic acid and the oxymuriatic acid are not correct. They prove that muriatic acid gas is a compound of a substance, which as yet has never been procured in an uncombined state, and from one-third to one-fourth of water, and that oxymuriatic acid is composed of the same substance (free from water) united to oxygen. They likewise prove, that when bodies are oxidated in muriatic acid gas, it is by a decomposition of the water contained in that substance, and when they are oxidated in oxymuriatic acid, it is by combination with the oxygen in that body, and in both cases there is always a union of the peculiar unknown substance, the dry muriatic acid with the oxidated body.

* Charcoal, over which sulphur has been passed, as in the experiment's page 407, as has been shown by M. A. Berthollet, contains sulphur, and this I find after being heated to whiteness; such charcoal is a conductor of electricity, and does not differ in its external properties from common charcoal.

Of all known substances belonging to the class of acids, the dry muriatic acid is that which seems to possess the strongest and most extensive powers of combination. It unites with all acid matters that have been experimented upon, except carbonic acid, and with all oxides (including water), and all inflammable substances that have been tried, except those which appear to be elementary, carbonaceous matter and the metals; and should its basis ever be separated in the pure form, it will probably be one of the most powerful agents in chemistry.

I have lately made several new attempts to procure uncombined dry muriatic acid; but they have been all unsuccessful.

I heated intensely, in an iron tube, silex in a very minute state of division, and muriate of soda that had been fused; but there was not the smallest quantity of gas evolved. In this case, the silex had been ignited to whiteness before it was used; but when silex in its common state was employed, or when aqueous vapour was passed over a mixture of dry silex and dry salt in a porcelain tube, muriatic acid gas was developed with great rapidity.

I have stated, page 79*, that a sublimate is formed by the combustion of the olive-coloured oxide of boracium in oxymuriatic acid. On the idea that this might be boracic acid, and that dry muriatic acid might be separated in the process, I examined the circumstances of the experiment; but I found the sublimate to be a compound of boracic and muriatic acid, similar to the compound of muriatic and phosphoric acid.

I heated freshly-sublimed muriate of ammonia with potassium; when the quantities were equal, as much hydrogen gas was developed as is generated by the action of water on potassium; much ammonia was evolved, and muriate of potash formed; when the potassium was to the muriate as 4 to 1, less hydrogen appeared, and a triple compound of muriatic acid, ammonia, and potassium, or its protoxide was formed, which was of a dark-gray colour, and gave ammonia and muriate of potash by the action of water. There was not the slightest indication of the decomposition of the acid in the experiment. The process in which this decomposition may be most reasonably conceived to take place, is in the combustion of potassium in the phosphuretted muriatic acid, deprived by simple distillation with potassium of as much phosphorus as possible. I am

* Page 116 of the present volume.

preparing an apparatus for performing this experiment, in a manner which, I hope, will lead to distinct conclusions.

LXI. *Account of certain Colours dug up at Pompeia.*

Read to the National Institute the 6th of March 1809.

By M. CHAPTAL.*

HER majesty the empress and queen did me the honour to present me with seven specimens of colours found in the shop of a colour merchant at Pompeia.

No. 1. seems to have received no preparation from human art; it is a greenish and saponaceous argil, such as nature exhibits in several parts of the globe; it is analogous with terra Veronica.

No. 2. is an ochre of a fine yellow, which has been cleansed by washing, as still practised, from all the principles which might injure its fineness or purity. As this substance becomes red when calcined in a moderate heat, the yellow colour, which it has preserved without any alteration, furnishes us with a new proof that the ashes which covered Pompeia were not very hot.

No. 3. is a reddish-brown of the same nature with what is now used in commerce, and employed for the coarse reddish paint applied to casks in sea ports, and on the doors, windows, and railings, belonging to some houses. This colour is produced by the calcination of the yellow ochre already mentioned.

No. 4. is a pumice-stone, very light and white; its texture is fine and serrated.

The three remaining packets contained compound colours, which I was obliged to submit to analysis in order to discover their constituent principles.

The first of these three, being No. 5, is a fine rich and deep blue; it is in small pieces similar in form. The exterior of the pieces is paler than the interior, which is brighter than the finest Saunders blue.

The muriatic, nitric, and sulphuric acids make a slight effervescence with this colour; they seem to brighten it, even after a long ebullition: the oxygenized muriatic acid has no action on it.

This colour has therefore no connection with ultramarine, which is destroyed by these acids, as observed by Messrs. Clement and Desormes.

* From *Annales de Chimie*, tome lxx. p. 22.

Ammonia has no action on it. When exposed to the flame of the blow-pipe, it becomes black, and forms a *fritte* of a reddish-brown colour, by the prolonged action of the flame. When melted by the blow-pipe with borax, it gives a greenish-blue glass.

When treated with potash on a platina saucer, it produces a greenish fritte, which first becomes brown, and ends in assuming the metallic colour of copper. This fritte partly dissolves in water: the muriatic acid when poured into the solution forms an abundant flaky precipitate, and the liquor, when decanted from above the first precipitate, furnishes a considerable additional quantity with oxalate of ammonia.

The nitric acid dissolves with effervescence the residue left undissolved by the alkali; the solution is coloured green. Ammonia forms a precipitate in it, which it redissolves when we pour it in excess, and the solution then becomes blue.

This colour therefore seems to be composed of oxide of copper, lime, and alumine; it resembles Saunders blue in the nature of its principles, but differs from it in its chemical properties; it seems to be the result, not of a precipitation, but the effect of a commencement of vitrification, or rather a true *fritte*.

The process by which the ancients obtained this colour seems to be now lost: all that we know, from consulting the annals of the arts, is, that the use of this colour is of a more ancient date than the destruction of Pompeia. M. Descostils has remarked a lively shining and glass blue on the hieroglyphical paintings of an Egyptian monument, and he ascertained that this colour was owing to the presence of copper.

Setting out from the nature of the constituent principles of this colour, we can compare it to nothing so well as the Saunders blue of the moderns: when we consider it with respect to its utility in the arts, we may with advantage oppose it to *ultramarine* and *azure*, particularly since M. Thenard has made known a preparation of the latter, which admits of its being employed with oil. But modern Saunders blue has neither the lustre nor the solidity of colour conspicuous in that of the ancients; while azure and ultramarine are much higher in price than a composition the three elements of which are of little value. It would therefore be of some importance to discover the processes by which this blue colour was prepared.

No. 6. is a pale-blue sand, mixed with some small
whitish

whitish grains. Analysis has discovered the same principles in it as in the preceding; we may consider it as a composition of the same nature in which lime and alumine are in stronger proportions.

No. 7. has a fine rose tint; it is soft to the touch; is reduced between the fingers to an impalpable powder, and leaves on the skin an agreeable rose-colour.

When exposed to heat, this colour becomes at first black, and ends in white. It gives out no perceptible smell of ammonia.

The muriatic acid dissolves it with a slight effervescence: ammonia produces in the solution a flaky precipitate, which potash redissolves entirely.

The infusion of gall-nuts and hydrosulphuret of ammonia did not denote the presence of any metal.

We may therefore regard this red colour as a true lac, in which the colouring principle is founded upon alumine. In properties, shade, and in the nature of the colouring principle, it has an almost perfect analogy with the madder lac which I have mentioned in my treatise on dyeing cotton. The preservation of this lac for nineteen centuries without any perceptible alteration, is a phenomenon which must astonish chemists.

Such is the nature of the colours presented to me by the empress: they seem to have been destined for painting: nevertheless, if we examine the varnish of the Roman earthen-ware, of which we find such immense quantities wherever the Roman armies have been, we shall be convinced that most of the earths in question have been employed in forming the varnish with which these pieces of earthen-ware are covered.

In fact, the greater part of these earthen-wares is covered with a red coating which has nothing vitreous in it, and which may have been given, either with yellow ochre, or with the reddish-brown kind, reduced by bruising to a fine paste, incorporated with a mucilaginous, gummy, or oily body, and applied with a pencil. M. d'Arcet, who has written a very ingenious work on the Roman potteries, is in possession of a vase, the composition of which is of a dirty red colour, and the surface has been covered with the coating above mentioned. We observe in it the place where the potter has left off covering it; and we perceive on the bottom, which is not coated, red streaks, which the workman had laid on, in order to clean his pencil, or to try the colour.

It is by no means rare to find other vases, the body of
which,

which is of a different colour from that of the red coating which covers the surface.

Perhaps the Romans even made use of saline fluxes to facilitate the baking of the coverings of their earthen-ware.

M. d'Arcet has completely imitated the white covering of the Etruscan vases by employing a shining white argil, with which he mixes a twentieth part of borax.

It should seem that the Romans were not acquainted, in the first century of the Christian æra, with the metallic fluxes for fixing and vitrifying the coverings of their earthen-ware: at least the analysis of the coverings of Etruscan vases, and of red, white, or brown earthen-ware, gave no indications of metal either to M. d'Arcet or myself. It was only in later periods that the sulphurets of copper and of lead, as well as the oxides of this last metal, were employed. We sometimes indeed find these metallic coverings on some vases that have been dug up, but their manufacture does not seem to me to have been posterior to the æra when the Romans occupied Gaul: for all those which I examined, and the origin of which is evidently prior to these first periods, presented no trace of copper or lead on analysis.

Sometimes the black colour alone presents characters of vitrification. I have seen several specimens of ancient earthen-ware, in which this is indubitable; and I have always thought that the vitreous lava formed the basis of these coverings, the fusion of which, naturally easy, was aided by the mixture of saline fluxes. I published my work on this subject twenty-five years ago: M. Fourmy has made a successful application of my discoveries in his manufacture at Paris, and M. d'Arcet has added his experience to mine.

To conclude: the earthen-ware of the Romans, particularly their Etruscan vases, have been baked in a much lower heat than that which we now employ: we may estimate the former at the seventh or eighth degree of Wedgwood's pyrometer: and at this degree of heat, as proved by M. d'Arcet, we cannot employ the oxides of lead, which penetrate the clay, and leave the colour on the surface without any brilliancy.

We are, without doubt, far superior to the ancients in the art of the potter. The numerous metallic oxides successively discovered, have furnished us with the means of enriching our potteries with a variety of colours as brilliant as they are durable, at the same time that a better assorted mixture of the earths has admitted of our adding the greatest
hardness.

hardness to an almost absolute infusibility: but the Etruscan vases will always be in request, in consequence of the beauty, elegance, and regularity of their forms; and every thing connected with the history and arts of the Roman people must be interesting to the progress of industry.

LXII. *On Respiration.* By WILLIAM ALLEN, Esq., F.R.S.
and WILLIAM HASLEDINE PEPYS, Esq., F.R.S.

[Concluded from p. 387.]

Experiment IV. Oxygen Gas.

THE pig hitherto employed was put into the glass vessel A, which with the tube contained 60 cubic inches of atmospheric air; 250 cubic inches of oxygen, containing 5 per cent. of azote, were admitted into the gasometer communicating with B, and during a quarter of an hour were made to pass slowly through the vessel in which the animal was confined, to the empty gasometer communicating with C, where it measured exactly 250 cubic inches; a portion was preserved in the mercurial bath for examination, and the gasometer B was replenished with 250 cubic inches of the same oxygen; this was passed in about the same time as before, through A into gasometer C, when it measured 248 cubic inches.

250 cubic inches more of the oxygen were now admitted into gasometer B, and passed in the same manner through A into C, where they measured 249.

The gasometer B was for the fourth and last time supplied with 250 cubic inches more of the oxygen, which were passed as before, through A into C, during about a quarter of an hour, and then measured 249.

The pig had remained in the vessel one hour and twelve minutes; it did not appear to have suffered in the least; portions of the respired gas were saved from each of the gasometers, and examined as usual.

	Cubic Inches.	Contained in 100 parts.	Carb. Acid.	Oxygen.	Azote.
No. 1.	250	Carb. acid	8	20	
		Oxygen	66	165	
		Azote	26		65
			<hr/>		
			100		
			<hr/>		

No. 2.

On Respiration.

	Cubic Inches.	Contained in 100 parts.	Carb. Acid.	Oxygen.	Azote.
No. 2.	248	Carb. acid	10	24.80	
		Oxygen	78	193.44	
		Azote	12		29.76
			<hr/>		
			100		
No. 3.	249	Carb. acid	10	24.90	
		Oxygen	80	199.20	
		Azote	10		24.90
			<hr/>		
			100		
No. 4.	249	Carb. acid	12	29.88	
		Oxygen	79	196.71	
		Azote	9		22.41
			<hr/>		
			100		
In Glass A, and tube C.	60	Carb. acid	12	7.20	
		Oxygen	79	47.40	
		Azote	9		5.45
	<hr/>		<hr/>	<hr/>	<hr/>
	1056		100	106.78	147.52
Total, gas before experiment,				1060	
after				1056	
				<hr/>	
Deficiency,		-		4	

Calculation for Oxygen.

We do not calculate upon the tube from gasometer B, because it is always in the same state after the experiment as before.

1000 cubic inches of oxygen containing
5 per cent. azote, consisted of 950 pure oxygen
60 Atmospheric air with the pig, and in
tube C, containing 21 per cent. oxygen 12.60

Total, oxygen before experiment, 962.60
Oxygen found after experiment, 801.75
Ditto in carbonic acid - 106.78

Oxygen missing, - 54.07

Calculation

Calculation for Azote.

1000 cubic inches containing 5 per cent. azote	50
60 atmospheric air, containing 79 per cent.	47·40
	<hr/>
Total azote before experiment,	97·40
Ditto found after experiment,	147·52
	<hr/>
Increase of azote,	50·12
	<hr/>

This increase of azote was much more than equal to the cubic contents of the animal's body, the deficiency of 4 cubic inches was doubtless oxygen absorbed.

Summary of the Experiment.

Barom.	Therm.	Oxyg. &c. inspired.	Gas after experiment.	Deficiency.	Carb. acid found.	Carb. acid per min.	Time.	Oxygen missing.	Azote added.
29·05	57°	1060	1056	4	106	1·48	1h. 12m.	54·07	50·12

Experiment V. Oxygen.

In this experiment we employed a smaller pig, which occupied the space of 33 cubic inches, and our object was to keep him for the same length of time in a smaller quantity of gas; we therefore only used 750 cubic inches of oxygen, beside the common air contained in the glass A, and tube, amounting to 66 cubic inches; the first 250 cubic inches were passed through the glass A into C in 24 minutes, where it appeared to have undergone no alteration of volume. 250 cubic inches more were passed during the next 23 minutes, and these measured 248 in C; the last 250 were passed in 24 minutes, and the volume remained unaltered. The animal did not appear to suffer the slightest inconvenience, except from the confinement.

State of the Gas before Respiration.

		Oxygen.	Azote.
66 cubic inches of atmospheric air,	=	13·86	52·14
750 oxygen, containing 5 per cent. azote,	=	712·50	37·50
		<hr/>	<hr/>
816	total consisting of	726·36	89·64
		<hr/>	<hr/>

The oxygen was tried before as well as after the experiment, and both the results agreed perfectly with each other.

We now examined portions of gas preserved from the three gasometers, with lime-water, and the tests for oxygen.

No.	Time. min.	Contained in 100 parts.	Carbonic acid.	Oxygen.	Azote.	
No. 1.	250.	24	Carb. acid	9.5	23.75	
			Oxygen	60.5	151.25	
			Azote	30	75	
			100			
No. 2.	248.	23	Carb. acid	9.5	23.56	
			Oxygen	81	200.88	
			Azote	9.5	23.56	
			100			
No. 3.	250.	24	Carb. acid	10	25	
			Oxygen	82	205	
			Azote	8	20	
			100			
66 with pig, as No. 3.			6.60	54.12	5.28	
<u>814</u>			<u>71</u>	<u>78.91</u>	<u>611.25</u>	<u>123.84</u>

Calculation for Oxygen.

Oxygen before the experiment	-	726.36
Ditto after	-	611.25
In carbonic acid	-	78.91
		<u>690.16</u>

Loss of oxygen 36.20

Calculation for Azote.

Azote found after experiment	-	123.84
Ditto before experiment	-	89.64

Increase of azote 34.20

Summary of the Experiment.

Therm.	Gas before Exper.	Gas after Exper.	Deficiency.	Carb. Acid found.	Cubic In. per minute.	Time.	Oxygen missing.	Azote added.
56.	816.	814.	2.	78.91	1.11	1 11	36.20	34.20

The

The quantity of azote added, of oxygen missing, and of carbonic acid formed, were smaller than in the last experiment; but the animal in this instance was smaller, as well as the quantity of oxygen passed through in a given time.

In this case, as in the human subject, the increase of azote takes place principally in the early periods. The whole azote contained in the 66 cubic inches, confined with the pig, was only 52.14; but supposing, which perhaps was not the case, that the 66 of common air were expelled by the first 250 cubic inches of oxygen, we should have 250

less 66

184 of oxygen,

containing 5 per cent. azote, or 9.20 cubic inches: these added to the 52.14, would make 61.34 of azote to be found in the first gasometer of respired gas, but we detected 75, so that even on this supposition 13.66 of azote were added in the first twenty-four minutes.

The azote contained in the second gasometer before respiration, was 12.50 cubic inches, but after it had been respired for twenty-three minutes, we found 23.75, or an increase of 11.25 azote. The azote contained in the third gasometer, before respiration, was, as before, 12.50 cubic inches; but after it had been respired for twenty-four minutes, we found 20, or an increase of 7.50 azote.

The azote contained in the 66 cubic inches was 3.30, but we found 5.28, or an increase of 1.98 azote.

From the results of these experiments, it seemed that when the usual proportion of azote was not present in the gas respired, there was a disposition in the blood to give out a certain quantity in exchange for an equal volume of oxygen, and we resolved to try, whether this circumstance would occur when hydrogen was substituted for azote; we accordingly made a mixture containing 22 per cent. oxygen and 78 hydrogen.

Experiment 6. Hydrogen and Oxygen.

The pig employed in the last experiment was placed upon the stand in the glass A, with 66 cubic inches of common air as usual.

250 cubic inches of the mixture were passed from the gasometer communicating with B, through the glass A into the gasometer communicating with C, during sixteen minutes. The animal did not appear uneasy: a second quantity of 250 cubic inches was passed in seventeen minutes

and three quarters: the animal did not seem to be in the least incommoded.

A third quantity of 250 cubic inches was passed, in about sixteen minutes.

And a fourth quantity of 250 cubic inches in eleven minutes and three quarters; but during this time the animal became very sleepy, and towards the end of the experiment kept his eyes constantly shut; he, however, appeared to suffer nothing, and was easily roused for a short time by rapping at the side of the glass. At the end of sixty-one minutes and a half he was taken out, and we found that during this time he had produced 60.20 cubic inches of carbonic acid gas, or rather less than one cubic inch in a minute.

It appears, that less carbonic acid was evolved in this instance in a given time, than when oxygen was respired, but some circumstances occurred to prevent us from discovering what change the azote had experienced: this point was, however, decided by the following experiment.

Experiment 7. Hydrogen and Oxygen.

Having mixed hydrogen and oxygen gases in such proportion as that the oxygen should rather exceed the quantity contained in atmospheric air, we placed the same animal in the glass A with 66 cubic inches of atmospheric air. 250 cubic inches of the mixture were admitted into gasometer B, from the large water gasometer, and gradually passed through the glass A into gasometer C, during fifteen minutes. The pig did not appear uneasy, and the respired gas measured 250 in C: a portion of this was preserved for examination, which we shall call No. 1.

250 cubic inches more of the mixture were admitted into B, and gradually passed, as before, during thirteen minutes; it measured 250 in C; and a portion No. 2 was preserved for examination.

The animal did not seem to suffer any inconvenience. 250 cubic inches more of the mixture were admitted into B, and gradually passed, as before, through A into C during seventeen minutes. The animal now became quite sleepy, but did not appear to suffer any thing. He was taken out at the end of forty minutes.

At the close of the experiment, the remains of the mixture, which had stood about an hour in the large water gasometer, being examined, was found to contain 22 per cent. of oxygen and no carbonic acid; of the residual 78 parts, 20 were mixed with 10 of oxygen, which had been previously

previously found to contain 3 per cent. azote; these 30 parts being detonated in Davy's improved Volta's eudiometer, by the electric spark, were reduced to 3 parts, and these 3 parts being treated with the tests for oxygen, were reduced to 2 parts, a proof that all the hydrogen had been consumed; but the 10 parts of oxygen contained 0.3 of azote; this deducted from 2, leaves 1.7 for the azote contained in 20 parts of the residuum 78.

$$20 : 1.7 :: 78 : 6.6$$

The mixture employed, therefore, contained in every 100 parts

22	oxygen
6.6	azote
71.4	hydrogen

100

We next examined the gas which had been respired.

No. 1. 250 cubic inches respired during fifteen minutes.

100 parts, subjected to the action of lime water in Pepys's eudiometer, were reduced to 93.5, and this by the tests for oxygen was further diminished to 77 : 20 parts of this 77, mixed with 10 of oxygen and detonated, the residuum treated with the tests for oxygen, left 12 parts which were azote.

From these 12	parts	
Deduct	.3	for the azote in the 10 parts oxygen,

Leaves 11.7 for the azote contained in 20 parts of the residual 77.

$$20 : 11.7 :: 77 : 45$$

No. 1. therefore consisted in 100 parts, of

6.5	carbonic acid
16.5	oxygen
45	azote
32	hydrogen

100

No. 2. 250. Respired during thirteen minutes; 100 parts were reduced by lime water to 92.5, and these by the tests for oxygen to 77. Of these 77 parts, 20 being mixed with 10 of oxygen, and detonated, were diminished to 4, and these 4 being examined for oxygen left 3, which must be azote :

From these	3
Deduct	.3 for azote in the 10 parts oxygen,
Leaves	2.7 for the azote contained in 20 parts of the residual 77.
	20 : 2.7 :: 77 : 10.4

No. 2. therefore consisted in 100 parts, of

7.5 carbonic acid
15.5 oxygen
10.4 azote
66.6 hydrogen

100

No. 3. 250. Respired during seventeen minutes; examined as above, consisted in 100 parts, of

6 carbonic acid
17 oxygen
6.5 azote
70.5 hydrogen

100

The 66 remaining with the animal at the close of the experiment, may be considered as very nearly the same as No. 3.

In this, as in the former experiment, we observed that the evolution of carbonic acid was greatest at the middle of the time, but was considerably diminished toward the end, as the pig became sleepy; it is not improbable, therefore, that during sleep less carbonic acid is evolved than when the animal is exercising all its faculties.

When atmospheric air alone is respired, we have uniformly found, that the carbonic acid evolved, added to the oxygen remaining, exactly equalled the oxygen existing in the air before it was respired, but in the present instance it was one per cent. more, a circumstance which we are at present unable to account for, but it was constantly the case in all the three trials.

Calculation for Azote.

From the foregoing statement we are enabled to ascertain the quantities of azote, both before and after the experiment.

Azote

Azote before the Experiment.

66	cubic inches atmospheric air, with the animal contained $\frac{7.9}{100}$ or	-	-	-	52.14
750	----- of the mixed gases contained $\frac{6.6}{100}$ or	-	-	-	49.50
<hr/>					
816	total gas employed	-	-	-	101.64
<hr/>					

The total azote before the experiment was therefore 101.64 cubic inches.

Azote after the Experiment.

		Respired during			
No. 1.	250.	15 min.	100 : 45 :: 250 :	112.50	
2.	250.	13 min.	100 : 10.4 :: 250 :	26	
3.	250.	17 min.	100 : 6.5 :: 250 :	16.25	
	66.		100 : 6.5 :: 66 :	4.29	
<hr/>					
	816	45 min.	Azote after experiment	159.04	
			Ditto before	101.64	
<hr/>					
			Increase of azote	57.40	
<hr/>					

Calculation for Hydrogen.

Hydrogen before Experiment.

The mixture before the experiment was found to contain 71.4 hydrogen.

$$100 : 71.4 :: 750 : 535.50$$

Therefore the total quantity must be 535.50 cubic inches.

Hydrogen after Experiment.

No. 1.	250.	100 : 32 :: 250 :	80
2.	250.	100 : 66.6 :: 250 :	166.50
3.	250.	100 : 70.5 :: 250 :	176.25
	66 in A	100 : 70.5 :: 66 :	46.53
<hr/>			
	Hydrogen found after experiment		469.28
<hr/>			
	Hydrogen before the experiment		535.50
	Ditto after		469.28
<hr/>			
	Loss of hydrogen		66.22
<hr/>			

In this experiment, as well as in those with oxygen, the proportion of azote evolved was greater in the early than in the later periods, and it becomes interesting to contrast them :

Thus we know that 52·14 cubic inches of azote were in the vessel with the animal at the beginning of the experiment, and that, of the 250 cubic inches of mixed gases passed in the first fifteen minutes, only 184 could be expelled into gasometer C, (100 : 6·6 :: 184 : 12·14) which contained only

12·14

making together 64·28 of azote, which was all that could have been expected in the first gasometer of 250 after respiration, supposing the whole of the common air had been expelled, but we detected 112·50, or an increase of 48·22 cubic inches in fifteen minutes.

The second gasometer, before it was connected with the glass A, contained but 16·50 cubic inches of azote; we found, however, about 26, and what is remarkable, in the last gasometer there was no increase at all.

Calculation for Carbonic Acid.

No. 1.	250.	15 min.	100 : 6·5 ::	250 : 16·25
	2.	13 min.	100 : 7·5 ::	250 : 18·75
	3.	17 min.	100 : 6 ::	250 : 15
	66.	-	100 : 6 ::	66 : 3·96
			45	53·96

The quantity of carbonic acid evolved in 45 minutes was therefore 53·96 cubic inches, or at the rate of 1·19 cubic inches per minute.

The foregoing experiments seem to prove,

1. That when atmospheric air alone is respired, even by an animal subsisting wholly upon vegetables, no other change takes place in it, than the substitution of a certain portion of carbonic acid gas, for an equal volume of oxygen.

2. That when nearly pure oxygen gas is respired, a portion of it is missing at the end of the experiment, and its place supplied by a corresponding quantity of azote; the portion evolved in a given time, being greater in the early than in the later periods.

3. That the same thing takes place when an animal is made to breathe a mixture of hydrogen and oxygen, in which the former is in nearly the same proportion to the latter, as azote to oxygen in atmospheric air.

4. That an animal is capable of breathing a mixture of

78 parts

78 parts hydrogen, and 22 oxygen, for more than an hour, without suffering any apparent inconvenience.

5. That the excitability of an animal is much diminished when he breathes any considerable proportion of hydrogen gas, or that it at least has a tendency to produce sleep.

6. That there is reason to presume an animal evolves less carbonic acid gas during its sleeping, than in its waking hours.

7. That the lungs of a middle-sized man contain more than 100 cubic inches of air after death.

These experiments have been conducted without reference to any particular theory, and indeed some of the results were so contrary to our preconceived opinions, that we have been induced to bestow more than ordinary attention on the subject. Confident, however, that all those who repeat the experiments with the same care will arrive at the same results, we shall rest satisfied with stating the facts, not without a hope that those brilliant discoveries of Professor Davy, which have already given us new views of the operations of nature, will in their progress furnish us with that explanation which it is in vain to expect at present.

Azote or nitrogen, for instance, has been considered as a simple or elementary substance; it is recognised, however, principally by negative properties. A very gaseous fluid which will not support life or combustion, which is not absorbed by water, nor acted upon by the tests for oxygen, nor capable of being detonated with oxygen gas, is generally pronounced to be azote: it is the constant residuum in almost all our experiments upon gases, but who shall say whether this residuum is a simple substance or a compound?

The experiment of Professor Berzelius leads us to suspect it of metallic properties; and those of Davy make it probable that it is an oxidated body; the subject is still under discussion. But we may fairly indulge more than a hope that the ardent zeal and well-directed labours of the philosophers just mentioned will throw a new and important light upon this obscure and difficult subject.

LXIII. *Description of certain Inventions for the Improvement of Naval Architecture, for increasing the Comforts of Mariners, and for facilitating Naval Enterprises. By Messrs. R. TREVITHICK and R. DICKINSON.*

[Continued from p. 391.]

IN our last Number we gave the advantages proposed to be derived from Messrs. Trevithick and Dickinson's improved system of towing ships, &c., by employing for this purpose the power of a steam engine, but without attempting to specify how they propose to apply this power. They mention two methods, both of them ingenious.—One of them is by employing a revolving wheel furnished with leaves to lay hold of the water, and worked by the steam engine. At first sight there appears no novelty in this idea, but the way in which they dispose of their wheel is perfectly different from any thing we have hitherto met with. It is placed in an air-tight receptacle open only at the bottom, in which the height that the water is permitted to rise (or, in other words, the depth of the dip of the wheel) is perfectly under the command of an air pump worked by the engine. Their second method, and which we would prefer, is as follows:

A wheel, or a sufficient portion of a wheel, to which an arm of considerable length is attached, receives an alternating motion by being worked into by a rack on the piston rod of the engine. The arm just mentioned is employed to give motion to a valve or valves included in a hollow trunk or prism attached to, or actually contained in, the vessel, placed longitudinally, and made of a size suited to the effect that is desired. The power of this application will be easily conceived from the following considerations:—When the stroke of an oar, or any similar implement, is made against water for the purpose of obtaining a reaction as nearly as may be similar to that of the resistance of an immoveable body, part of the force is lost in producing a lateral motion in the water, which escapes sideways, and the blade of the oar is far from being stationary. If the oar were to pass in a channel or groove to which it fitted, and of such a length as to present a long prism of water before the oar which could no otherwise move than by passing out of the channel, it is demonstrable that the mass of the said prism of water may be assumed of such a magnitude as to render the actual motion of the oar by a given force, and during a given time, less than any assignable quantity. Now this is precisely the principle

ple of which Messrs. Trevithick and Dickinson have availed themselves. Their valve or valves are attached to a rod in the hollow trunk, which rod being connected with the arm of the steam engine receives a reciprocating motion like a piston, and thus opens and shuts the valves alternately. If the hollow trunk be of sufficient dimensions, it is evident that its contents will have so much inertia or resistance as to receive but little velocity from the piston, and that the surplus power must carry the vessel forward in an opposite direction.

If the hollow trunk be made moveable and attached to the rowing arm, and there be a stop within, of the nature of a valve, to shut against the stroke and open with the return, the effect will be the same as with the former arrangement, but the machinery would probably be more cumbrous and apt to get out of repair.

III. *Sliding tubular Masts, made of Iron, and so constructed that the upper ones slide into the lower, in a Manner somewhat like a Pocket Telescope.*

“ A hollow iron mast of the thickness of half an inch, and of the same height and diameter as a wooden mast, will be much lighter, considerably stronger, much more durable, less liable to be injured by shot, and can be easily repaired, even at sea. It will weigh only 12 tons, and at 45*l.* per ton will not cost more than 540*l.*, while its strength will be nearly fifty per cent. over that of a wooden mast that weighs 23 tons, and costs nearly 1,200*l.*

“ This mast is made to strike nearly as low as the deck, to ease the ship in a heavy sea—Wooden masts are, in such circumstances, obliged to be cut away. Ships furnished with these masts will not, like others, be exposed to the risk of receiving damage from lightning. The iron mast being itself an excellent conductor, by using an iron bolt from the bottom of the mast, through the keelson and the keel, the electric matter will be conducted through the bottom of the ship into the water, without injury to the ship.

“ Yards and bowsprits may also be made of wrought iron, at the same proportion of strength and expense as the mast. Chain shrouds and stays made of iron* may

* Since this prospectus was first circulated (Feb. 10, 1809.) we have learnt that the idea of employing iron rigging has actually been carried into effect by a Lieut. Brown; and a vessel rigged in this manner, but with wooden masts, is now to be seen in the West India Dock. The first proposal, however, that we have heard of for using metal in rigging was from Mr. Tuloch, in the year 1801. *Phil. Mag.* vol. xxi. p. 108.

also be used with those masts, and will not cost half the expense of rope, while they will also prove ten times more durable. For many other purposes in shipping, wrought iron, employed as a substitute for the materials now in use, would have as great advantages as in the articles above mentioned. Even the whole hull may be made of wrought iron.

IV. *Préparation of Ship Timbers, and improved System of Building.*

“ For a long period the only means employed to effect the bending of ships’ planks was by exposing them to the heat of open fires, and in most parts of Europe this is still the practice. As hitherto conducted, it has been found to be a tedious slovenly process, attended with a great expense of fuel, and unequal in its effects, some parts being only partially heated, while others are burnt.

“ Another system was therefore resorted to, that of employing steam; and it must be allowed that this mode of bending has been found to answer so far as the interest of the ship-builder is concerned; but the ship-owners have suffered from its effects. It is possible by means of steam to give the required degree of flexibility to planks; but steam of a degree of temperature high enough to destroy the vegetable sap cannot be confined in vessels of any reasonable strength. Wood so treated has been found liable to sudden decay: nor is this, which is an important objection, the only one to which steaming is liable. When planks beyond a certain thickness are bent in this way, they are found to be injured from the temperature being too low to give the required flexibility; and, owing to the want of a better method, the curving of strong timbers has hitherto been impracticable.

“ It is well known that the decay of a ship originates and takes place in the timbers and inside the planks, by their being precluded from a free circulation of air to evaporate the natural vegetable sap of the wood.

“ The process now recommended is for heating both planks and timbers, without steam, and in such a manner that they may be enveloped and equally surrounded on all sides with hot air and smoke; the coal tar contained in the latter entering at the same time the pores of the wood, and acting as a feeder. This process is so conducted as to prevent the wood from being burnt by it: all the air that reaches the timbers, while under process, being previously obliged to pass through the fire, and being, by that means,
deprived

deprived of its oxygen, or that principle which maintains combustion, no burning can take place.

“ The means employed to effect this are horizontal curvilinear flues, made of cast iron, adapted to the forms intended to be given to the wood, and furnished with a powerful, but simple, apparatus for applying the force requisite to bend the timbers into the required form.

“ By this process even timbers of large dimensions can be bent to almost any shape. They are heated throughout their whole length and substance, without alternations of temperature in the different parts, as when exposed to open fires.

“ By this process the necessity of procuring bent timbers is done away; while, at the same time, that loss which is incurred by cutting straight or ill-shaped timbers into proper forms, is avoided, and that weakness which results from cutting cross the grain and from scarfing is obviated.

“ By this process also there will be a saving of that waste of time which is necessary, in the ordinary process of ship-building, for *seasoning*, as it is called; and, which is of great importance, much of the labour now bestowed on trimming and chipping, to give form both to straight and crooked timbers, will be avoided, while the natural strength of the pieces will be left unimpaired.

“ The preparation of ship timbers, as above described, applies to the system now in use, in which the framing consists of pieces of wood, bent by nature, and brought into form by sawing and chipping. The pieces to which we allude are known by the name of ribs, and much of the strength of the present structure of ships is attributed to them.

“ But strange as it must appear to those who have never once started a question on the subject, the ribs give but little strength, comparatively, and we propose to discard, almost entirely, from ship-building those pieces called ribs, and to present to our country a system infinitely preferable in point of strength, cheapness of construction, durability, and the facility with which the requisite materials may be obtained.

“ We beg to premise, that the principal defect of the present method lies in this:—The ribs owe what stability they possess in the structure entirely to the connexion they have with the beams, planks, and lining, having but little of their own. Their stability depends on the structure of the planks with which they are covered, and which are attached to them within and without. They afford little or no direct support

support to each other; and hence the facility with which the ship breaks in two, when by any accident the middle is grounded, while the stem and stern are in deep water. The reason is obvious: in such a case there is nothing to bear the strain but the keel, the planks, and lining. In fact, the ship receives a disposition to break from the moment she is launched; for the middle of the ship displaces a greater quantity of water, foot for foot of the keel, than either of the ends, and, of course, performs the office of a floating fulcrum, acted upon by the gravity of the ends. This evil cannot be removed while the present form is retained; but the ship may be strengthened in her structure, to enable her the better to resist that tendency.

“ A ship, as at present constructed, consists of the ribs, and of the inside and outside planks, the planks crossing the ribs nearly at right angles. It is a threefold structure, in which, using round numbers, the outside planks occupy $\frac{1}{4}$ th, the ribs $\frac{1}{2}$, and the inside planks $\frac{1}{4}$ th of the thickness.

“ Now it might be demonstrated, were that necessary, that if the space now occupied by the ribs was supplied by a double row of planks, bent into the required curves, placed in the same order as the ribs, and so disposed that the joinings of each row respectively should be covered by the solid parts of the other, that then a stronger structure would be obtained than results from the present method of a single row of ribs. In adopting the method just mentioned, straight-grained planks of the greatest lengths might be used, and consequently the numerous scarvings and joinings of the present system be almost entirely done away. The advantages to be hence derived, in point of strength, and facility of obtaining proper materials, are obvious.

“ But though the above would be a great improvement, it falls infinitely short of the perfection to be obtained by employing the very same materials in a still more scientific manner.

“ We have already proposed to substitute two rows of bent planks for the present ribs; but there is no necessity that these should, as in the present system, be at right angles to the outside planks and the lining. To obtain the greatest possible degree of strength from the same quantity of materials, the bent planks, employed as substitutes for ribs, should cross each other at the keel, and consequently up the sides of the ship, at such an angle as to form with each other, at the points of intersection, a kind of lozenge. By such an arrangement, each row crossing the other at an angle—the one as it rises from the keel taking an

an angle forward, (say of 50° or 55°) and the other a like angle aft, they exert their strength in different directions, and the whole are made to act as a combination of so many diagonal spurs giving strength and solidity to the structure.

“ A slight examination will be sufficient to convince any person, habituated in investigating questions connected with the strength and œconomy of materials in scientific mechanism, that a ship so constructed must be, at least, twice as strong as one built according to the plan in common use. Nor is this all! When a ship of the common construction starts a plank, by labouring in a heavy sea, nine times out of ten she founders; but one built on this plan, in such an event would still be a safe bottom; the crossing of the rib-planks preventing the admission of water in such quantity as to be beyond the power of moderate pumping to keep under.

“ To insist on the advantages in point of œconomy, and the diminished number of joinings, from being enabled to employ straight-grained planks, at all times to be obtained with comparative ease, and of considerable lengths, would be to insult those to whose consideration our *System of improved Ship-building* is submitted. Were this adopted, there would be no need to send persons abroad to buy timber; our own forests are sufficient to supply us with the straight timbers for 100 years to come, and at half of the expense, during which time more would be growing.

[To be continued.]

LXIV. *Of the Action of Vegetable Acids on Alcohol, both with and without the Intermedium of the Mineral Acids.*

By M. THENARD. Read at the Institute on the 23d of November 1807*.

SCHÉELE is the only chemist who has hitherto employed himself on the question which is the subject of this paper. At first he was convinced that neither the acetic, benzoic, tartaric, citric, nor succinic acid formed ether with pure alcohol: afterwards, wishing to ascertain if those acids were susceptible of producing it, with alcohol and the mineral acids sulphuric, nitric, and muriatic, he made for this purpose various experiments, from which he has concluded †,

1st. That the acetic acid and alcohol form, with one of

* From *Mémoires d'Arcueil*, tome ii. † Vide les *Mémoires de Scheele*.

the three preceding mineral acids, an ether which is easily decomposed by potash, and which contains acetic acid.

2d. That the benzoic acid and alcohol produce with the muriatic acid a kind of oil heavier than water, which may, like the acetic ether, be decomposed by potash, and which has the benzoic acid for one of its principal ingredients.

3d. Lastly, that he obtained no particular product by treating the tartaric, citric, or succinic acid, dissolved in alcohol, with either the sulphuric, nitric, or muriatic acid.

Thus it was known to Scheele that the acetic ether contains acetic acid, and that the oil of benzoin contains benzoic acid; but he was not acquainted with the other principles of which they are composed, nor did he understand the action of alcohol and the mineral acids in the formation of these compound species. From that alone we may conceive that, had he drawn some conclusions from his experiments relative to the formation of these compounds, he would have admitted in the acetic ether and oil of benzoin, a vegetable acid, as well as the mineral acid and alcohol employed, or have considered them only as new bodies derived from the alcohol decomposed by the mineral acid; or as new bodies and the mineral acid itself.

This triple hypothesis is sufficient proof that the experiments which gave birth to it are incomplete; it was necessary therefore to repeat them, which I have done with so much the less trouble, as they are immediately connected with those experiments I have been engaged in upon ethers, which not only presented me with very singular results, but also promise to be of great importance.

In the division of my researches I have followed the example of Scheele, examining in succession the action of the pure vegetable acids on good rectified alcohol, and of the same acids mixed with the mineral ones.

Almost all the vegetable acids dissolve in alcohol, and separate again from it by distillation, without affording any particular results, however often the same portion of alcohol is distilled from the same portion of acid: this I know to be the case with the tartaric, citric, malic, benzoic, oxalic, and gallic acids; and I have not the least doubt, although I have not made the experiments, but that the suberic, succinic, mucic, pyro-tartaric, moric, and homigstic acid, are in this respect similar. But it is very different with the acetic acid. Its action upon alcohol is such, that by means of many distillations both bodies disappear and form a true ether: hence I conclude, that this probably is the only one, of all the vegetable acids hitherto known,

known, which can present us this or any analogous phenomenon.

But when, instead of placing the vegetable acids in contact with the alcohol, they are put at the same time in contact with this liquid and one of the mineral acids, strong and concentrated new combinations of very remarkable natures may be formed with all of them, as the following experiments are intended to show.

Experiment I.—I took 30 grammes of benzoic acid dissolved in 60 grammes of alcohol, I introduced the solution into a tubulated retort, and added 15 grammes of concentrated muriatic acid; then having adapted a tubulated balloon to the neck of the retort, and a bent tube to the tubulure of the balloon, I commenced the distillation, and stopped it when nearly two-thirds over.

During the whole experiment no gas, but common air and slight traces of muriatic acid were disengaged. The first portions of the product distilled consisted solely of alcohol; but the last contained a peculiar kind of matter separable from the alcohol by water: there was much of it in the bottom of the retort, where it had been condensed by the cold; and as it was covered by a mixture of alcohol, water, muriatic and benzoic acids, I purified it by decantation, and by washing it with warm water, in which it was very slightly soluble. Thus purified, it was of a yellowish colour, rather heavier than water, pungent, fusible from the temperature of 25, to 30, volatile nearly at 80, acid, oily, almost insoluble in cold water, less in boiling water, from which it precipitated itself on cooling, and very soluble in alcohol, from which water separated it. It evidently contained the benzoic acid, for to this acid it owed its property of reddening tincture of turnsole. Neutralized by an alkaline solution it was white, and always sharp and odorous; it constantly showed most of the preceding properties, and was generally perfectly liquid at the ordinary temperature: lastly, when long agitated in a solution of caustic potash, it disappeared without emitting any gas; and the solution examined, presented no traces of muriatic acid, and nothing absolutely but benzoic acid and alcohol could be recovered.

This matter then which presents itself to us in an oily state, in which apparently there is no acid, is formed by a peculiar combination of alcohol and benzoic acid; yet it can be obtained neither by repeatedly distilling together benzoic acid and alcohol, neither by precipitating by water the benzoic acid from its solution in alcohol, nor by

strongly concentrating this solution and allowing it to pursue its natural course. Thus, though muriatic acid is not one of the constituents of this singular body, and although the two bodies which form it are in each other's presence, yet it cannot be produced without the assistance of the acid; which result, extraordinary as it may appear, is nevertheless of the greatest authenticity, as we shall presently endeavour to show: but first let us be satisfied whether the other vegetable acids are similar to the benzoic in their action on alcohol.

Experiment II.—Having made a solution of 30 grammes of oxalic acid in 36 grains of alcohol, and added 10 grammes of concentrated sulphuric acid, the mixture was distilled until sulphuric ether began to be formed; it passed into the receiver like alcohol slightly etherized, and it left in the retort a brownish liquor of great acidity, which, on cooling, subsided like crystals of oxalic acid; but when water was diffused over this liquid, a substance separated similar to that given by the benzoic acid, slightly soluble in water, produced in a pretty large quantity, and capable of being purified by washing with cold water, and by abstracting, by means of a little alkali, the excess of acid retained. Treating in the same manner the citric and malic acids, results precisely similar were obtained. The three substances procured from these three acids resemble each other in some of their properties: all are of a yellowish hue, rather heavier than water, destitute of smell, perceptibly soluble in water, and very soluble in alcohol, from which water precipitates them. In taste they differ: that procured from the oxalic acid is slightly astringent, that from the citric very bitter, but what taste the other has I do not know. The first is volatile; it is rather more so than water; by this means it is easily made white. It was particularly interesting to acquire an intimate knowledge of the nature of all three. I was inclined to believe that their decomposition might be effected by distillation in a solution of caustic potash, and that the first would afford me oxalic acid, the second citric, and the third malic; that all would give me alcohol, and be free from sulphuric acid: the facts were according to my expectations. Here then we possess new combinations of the vegetable acids and alcohol, in the formation of which the sulphuric acid has performed the same part as the muriatic did in the preceding experiments.

After this, it became very probable that the other vegetable acids acted towards alcohol in the same manner as the
the

the preceding; yet to be quite certain I resolved to submit some of them to a rigorous trial, and for the purpose I made choice of the gallic, tartaric, and acetic acids, the other acids being either difficult to procure or insoluble in alcohol.

The experiment with the gallic acid had not that success I desired, because I operated on no more than 10 grammes of acid: the combination was always produced; for, after having distilled these 10 grammes of gallic acid with 12 of alcohol and 4 of sulphuric acid until half the original quantity of the mixture remained, I found in the retort a liquor, which, when covered with water and saturated with potash, gave me, by a fresh distillation, all the free alcohol it contained, and which, when mixed with potash in excess, afforded me another portion: this last could alone be that which was combined with the gallic acid.

On the contrary, with the tartaric acid the experiment completely succeeded, and furnished some curious results. Here, I employed as before with the oxalic acid 30 grammes of the vegetable acid, 35 of pure alcohol, and 10 of concentrated sulphuric acid. The distillation was carried on till a little ether began to be formed: at this period the fire was lowered in the furnace, and the retort allowed gradually to cool. The liquor, whilst cooling, assumed the consistence of a thick syrup. I poured water on it, but in vain, with the hope of separating, as in the preceding experiments, the peculiar combination of acid and alcohol: then, having successively added to this liquor different quantities of potash, a large precipitate was formed of the acidulous tartrate of potash; and having saturated it without passing the neutral point, having evaporated it, and subjected it when cold to strongly concentrated alcohol, I obtained, by evaporating the alcoholic solution, a substance which, when cool, became of the consistence of thick jelly, and even with greater ease than before; it was treated with potash and alcohol.

This substance is of a brownish colour, and is slightly bitter, nauseous, inodorous, free from acidity, and very soluble in water and alcohol; it does not precipitate muriate of lime, but abundantly the muriate of barytes: during calcination it emits dense fumes possessing a strong smell of garlic; at the same time it leaves no alkaline but a carbonaceous residue, which contains a considerable quantity of sulphate of potash: in a word, when it is distilled with potash, plenty of alcohol and a large quantity of tartrate of potash are extracted from it. Hence it is evident that

this substance is another combination analogous to the preceding; but it is most remarkable for its syrupy consistence, and the property which it has of rendering soluble in the most concentrated alcohol, sulphate of potash, which alone is insoluble in weak alcohol. Perhaps it was the peculiarity which it has of not appearing oily, as the other combinations of this kind do, to the sulphate of potash.

Having concluded the experiments on the benzoic, oxalic, malic, citric, gallic, and tartaric acids, those only on the acetic remain to be made. I adhered to these experiments so much the more, as I concluded that, by varying them, light would be thrown on the true manner of the action of the mineral acids in producing the new combinations we are considering. In all these experiments I have used alcohol of the specific gravity of 800 (temperature 10 degrees of the centigrade thermometer) and the acetic acid capable of crystallization at 0.

Experiment I.—I subjected a mixture of 30 grammes of alcohol and 20 of acetic acid to one distillation only: a pretty intense heat was necessary to boil the liquor, and some grammes of acetic ether were with difficulty formed.

Experiment II.—I repeated the preceding experiment, but with the addition of 5 grammes of sulphuric acid to the mixture of alcohol and acetic acid; 19 grammes of acetic acid disappeared, ether was formed with singular facility, and almost without any heat, I obtained 40 grammes. It follows then that the preceding process is an excellent one for the manufacture of acetic ether, and far superior to that in present use, both because a greater quantity of ether is produced, and because many distillations are not requisite to procure it. The rectification of it is always easy, nothing more being necessary than to add a little potash and to decant, for the acetate of potash formed is collected at the bottom of the vessel.

Besides, an excellent ether may be economically made, by adding to three parts of acetate of potash and two of strongly concentrated alcohol, two parts of the most highly concentrated sulphuric acid; the mixture is to be introduced into a tubulated retort, and to be distilled to perfect dryness; then the product is to be mixed with one-fifth of its weight of the strongest sulphuric acid, and by a skilful distillation as much ether may be procured as there was alcohol employed. Any other acetate, and particularly that of lead, may be substituted for the acetate of potash: but then it is necessary

cessary to employ other proportions of alcohol and sulphuric acid, which will be presently pointed out.

Experiment III.—When less than 5 grammes of concentrated sulphuric acid is used to convert 20 of acetic acid into ether, the experiment does not perfectly succeed—and only partially when sulphuric acid not concentrated is employed; but it fails entirely when the acid is much diluted with water.

Experiment IV.—When either the concentrated nitric or muriatic acid is employed to convert acetic acid into acetic ether, more of either must be used than of the sulphuric, and their quantity must be increased according to the water contained.

Experiment V.—The phosphorous acid reduced to a syrupy consistence readily facilitates the formation of acetic ether; but it is necessary that the quantity of this acid should be at least equal to two-thirds of the acetic acid, that the whole of the latter may disappear at the first distillation.

Experiment VI.—Both the arsenic and oxalic acid contribute but in a slight degree to the formation of the acetic ether.

Experiment VII.—The tartaric acid is of no use whatever in this process.

Experiment VIII.—The sulphurous acid gas does not favour the formation, though it is very soluble in alcohol, and produces much heat during its solution.

Experiment IX.—Lastly, the same takes place with the phosphoric acid; but it is because this acid is insoluble or only slightly soluble in alcohol.

It is evident, when we examine the result of these experiments, that all the acids which concentrate alcohol favour the formation of acetic ether, and they contribute to it proportionably to the power each has of concentrating alcohol. On this account, the sulphuric acid has the greatest influence, and the tartaric scarcely any; but when the sulphuric acid is much diluted with water, it has the same effect as the tartaric. It is necessary therefore to suppose that, when the alcohol is thus condensed by an acid, the acetic acid seizes on it, and by a peculiar combination forms acetic ether. Now one cannot refuse to admit an analogous action on the part of the strong and concentrated acids, either to generate the acetic ether, or to unite the other vegetable acids with alcohol: consequently, in the whole series of combinations we have observed, which could not have taken place without the interference of a strong mineral

ral acid, this mineral acid acts no other part than that of condensing the alcohol, and of bringing it into a state capable of uniting with the vegetable acid. The following principle may then be established, to express in a general manner the facts I have presented in detail in this memoir.

When the vegetable acids are pure, there are none of them, excepting the acetic, which can in any way unite to alcohol and lose their acid properties: but on the contrary, when mixed with one of the mineral acids capable of strongly condensing alcohol, all these acids form with alcohol combinations destitute of acid properties, and free from the mineral acid. This principle being granted, there is no reason for its not including the animal acids. Probably it will lead us to a knowledge of the secret nature of the mineral acids, and we shall thereby discover the means of easily combining them with alcohol; and it will even perhaps enable us to combine all vegetable and animal substances, if not with all the acids, at least with the strongest and most concentrated. This is certain, that it is fruitful in results, since it increases our means of giving new combinations to matter.

Be this as it may, searching in every direction to verify these ideas, I occupied myself on different objects, which I have passed unnoticed in this memoir. I endeavoured to ascertain whether the sweet oil of wine was not composed of alcohol and sulphurous acid, and whether that kind of oil procured by passing oxy-muriatic acid gas through alcohol, is not a compound of alcohol or another body, and muriatic acid. I examined the properties of different combinations, of which I shall presently give an account. I endeavoured to decompose them by different salts, and thus to combine, by means of double decompositions, alcohol with all the mineral acids. I attempted also to discover whether a perfect identity exists between those kinds of combinations, the formation of which is indirect, and the nitric and muriatic ethers, the formation of which is direct. Lastly, I endeavoured to determine if really, independent of the condensation, the mode of combination is the same, when the vegetable acid dissolves in alcohol retaining its acid properties, and when, on the contrary, it intimately combines with that body, with the loss of its properties.

LXV. *On the Combination of Acids with Animal and Vegetable Substances.* By M. THENARD.

MY researches upon the nitric, muriatic, and acetic ethers, and upon those obtained by treating alcohol with muriate of tin and oxy-muriatic acid*, have naturally led me to examine if it was possible to form them with the other acids. I have tried the action of these acids upon alcohol; and it was in making and varying these experiments I arrived at the singular result which I have had the honour to communicate to the Institute†; a discovery, that when the vegetable acids are pure, none of them, excepting the acetic, combine with alcohol with the loss of their acid properties: but on the contrary, when mixed with a mineral acid capable of condensing alcohol strongly, they all form with that body a combination in which their acid properties disappear, without the mineral acid taking any part in this combination.

It is evident then, that whatever may be the mode of the combination of alcohol with a vegetable or mineral acid, the alcohol produces in these compounds the effect of a true saline base.

Now the question is, whether the property of combining with acids, and also of neutralizing them, does not belong to all animal and vegetable substances. It is very possible that this is the case; for, since alcohol possesses this property, all these substances may also possess it. It was with a view to solve this question that the following experiments were made.

I passed over 300 grammes of alcohol, oxy-muriatic acid gas made from a mixture of 1750 grammes of muriate of soda, of 450 grammes of black oxide of manganese, of 800 of concentrated sulphuric acid, and of 800 grammes of water.

Almost all the acid and the principal part of the alcohol were mutually decomposed, and either generated or liberated a large quantity of water, of matter having an oily appearance, of muriatic acid, and a small quantity of carbonic acid, and a substance abounding in carbon; a result that agrees with what has already been published either by M. Berthollet in the *Memoirs of the Academy*, or by myself in the first volume of the *Mémoires d'Arcueil*. All these products have been separated with care, as I have

* Vol. i. *des Mémoires d'Arcueil*.

† See the preceding Memoir.

noticed in those Memoirs; one only has been subjected to a new examination, and that is the oily matter.

When carefully purified by water and potash, it has the following properties, some of which have been already observed in the memoirs I shall quote. It does not redden turnsole paper; it is white; it has a cool taste similar to that of mint, and a particular but not ethereated smell; it is heavier, yet less volatile, than water; it is very soluble in alcohol, but very slightly in water. It is volatilized by distillation with nitric acid, and partly decomposed; but the products of this decomposition vary according to the strength of the acid used. If the nitric acid be weak, much muriatic acid is produced, and little oxy-muriatic: if, on the contrary, the acid be concentrated, little muriatic acid is procured, but much oxy-muriatic acid: of course this substance contains a very considerable quantity of muriatic acid. In the same manner, when it is passed through a red-hot iron tube a large quantity of acid is disengaged. Yet it is decomposed but very slowly by the strongest alkalis, even when dissolved with them in alcohol: hence the conclusion must be drawn, that the muriatic acid it contains is intimately combined with another substance. I have not yet succeeded in discovering what this substance is, because I have not been able to separate it from every thing else. Whatever that may be, it is certain that it is capable like the alkalis of neutralizing acids; and it may be presumed that it contains a large quantity of carbon, since in the decomposition of alcohol and oxy-muriatic acid, much water and very little carbonic acid are produced.

But of all the vegetable substances, I am acquainted with none that possess the property of uniting themselves to acids, in a more eminent degree than some of the essential oils; perhaps even all of them enjoy this property. That of turpentine absorbs nearly one-third its weight of muriatic acid gas, and becomes converted, with the emission of much heat, into an almost entire crystalline substance. Kind some years since discovered it; its nature was afterwards studied by Tromsdorff and some French philosophers, and last of all by Gehlen. All these chemists except Gehlen have considered it as an artificial camphor, because it had the smell, volatility, lustre, whiteness, and many other properties of natural camphor; and comparing the action of muriatic acid on oil of turpentine, with that of sulphuric acid on vegetable substances, they have conceived that the transformation of this oil into camphor is solely

solely to be attributed to the loss of oxygen, and hydrogen being abstracted in sufficient quantity by the muriatic acid to form water, and to a slight separation of carbon at the same time: in fact, that the artificial camphor with a little more carbon, and a certain quantity of oxygen and hydrogen in the proportions to constitute water, would return to an essential oil.

Gehlen rejected this theory for good reasons*. Having observed that in passing muriatic acid through the essential oil of turpentine, no gas was disengaged; that only a certain portion of the oil was converted into white crystals having the appearance of camphor, and that the remainder appeared as a brownish-black liquid of great acidity; that the crystals too as well as the liquid contained muriatic acid in intimate combination, &c. he has concluded, that in this operation the essential oil of turpentine is decomposed, that the greatest part of its hydrogen combines with a small quantity of its carbon, and with a certain portion of muriatic acid, to form concrete camphor, whilst the other principles of the oil combine with the remaining portion of muriatic acid to form the brownish-black liquid; therefore that this liquid contains more carbon and less hydrogen than the camphoric concretion; and that, in the formation of both, the muriatic acid acts only by the tendency it has of uniting to them, and not, as the chemists above quoted say, by forming a certain quantity of water at the expense of the principles of the essential oil.

I repeated and varied with great care the experiments on the essence of turpentine and muriatic acid, made by Kind, Tromsdorff, &c., and above all by Gehlen. I obtained the following results: 100 grammes of essence of turpentine purified by distillation, and plunged into a freezing mixture of ice and salt, absorbed 30 grammes of muriatic acid gas; no gas but muriatic escapes, which perhaps was not entirely absorbed at first, or passed through the liquid when the operation was nearly finished. The essential oil is converted into a soft and crystalline mass, from which, during its desiccation for three days, may be separated 20 grammes of a liquid that contains many crystals and nearly 100 grammes of a white substance, granular, crystalline, volatile, and having a strong smell of camphor. This substance quickly loses, by exposure to the air, the property which it at first has of reddening turnsole paper, and afterwards only very minute quantities of acid can be separated

* Vide *Journal de Gehlen*, tome vi. p. 458.

from it, even by warm alkaline solutions. Yet when it is sublimed, the vessels in which the operation is made become strongly acid; and when, instead of subliming it, it is passed through a red-hot iron tube, a greater quantity of acid is still abstracted from it. Lastly, when decomposed both by concentrated and weak nitric acid, a large quantity of oxy-muriatic acid is produced in the first instance, and in the second much muriatic acid. Relative to that portion of liquid derived from the crystalline mass, the weight of which was 20 grammes, it was white, and diffused acid vapours, but ceased after an exposure of some days to the atmosphere, and was no longer acid; it crystallized in mass some degrees below zero, and preserved an intimate union with much muriatic acid.

Thus all my observations, except one only, agree with those of Gehlen. That in which we do not coincide is relative to the liquid product of the operation. Gehlen obtained it of a brownish-black, and I always obtained it white. This difference, I think, depends on Gehlen having used the essence known in commerce, which contains, unless distilled with great care, a resin, and has then the property of blackening and forming a large uncrystallizable residue. Neither do I draw from my observations the same theoretical inferences as this chemist does from his. I think that the essential oil of turpentine is not decomposed by muriatic acid, and consequently that these two bodies combined together in certain proportions form concrete camphor; probably the small portion of liquid product obtained by him is of the same formation: besides, it is not improbable that the difference existing between the camphoric concretion and the liquid product, depends on a small quantity of an ethereal oil mixed with the essence, and capable of forming with muriatic acid a liquid product. Lastly, what induces me to believe that the muriatic acid does not decompose the essence, but, on the contrary, combines with it, is, that this acid evidently combines with all the principles of alcohol without affording many different products, and that alcohol is a hydrogenous body as well as the essential oil of turpentine. Yet whatever it may be, nothing is more certain than that this combination has the greatest resemblance to native camphor.

Perhaps the camphor which is extracted from the essential oils of plants, particularly from that of lavender, is a combination of essence and acid alone; perhaps too the camphor of commerce, or the camphor of the laurèl, which does not appear to contain any mineral acid, (for none can

be obtained from it by destructive distillation,) is formed of an essential oil and vegetable acid alone. These views, as they are founded on facts, at least deserve some attention, and, if confirmed by experience, may probably be of great advantage.

I have likewise formed the combinations of the essence of lemon and of lavender with muriatic acid. 32 grammes of the essence of lavender require 22 of acid; the resulting compound is blackish, acid and liquid. 26 grammes of the essence of lemon absorb 22 grammes of acid; the essence is of a brownish hue and solid. Neither of these essences had been purified; but both were used in the state they are generally found in commerce.

The essential are not the only oils capable of combining with acids. It has long been remarked that the fat oils form with different acids peculiar kinds of soap. The sulphuric acid when concentrated has this effect upon all of them; it produces with the oil of olives in particular a soapy matter, of a thick and greenish appearance, which gradually acquires consistence; when washed with water it becomes white; it is acid, but less so than if the acid was uncombined, and it may be brought into the neutral state by a proper quantity of potash.

Tannin besides, which is a vegetable matter, contracts, as is well known, a strong union with acids; for the concentrated sulphuric acid suddenly precipitates it from its solution in water, and I am convinced that, however often the precipitate may be washed, it is always acid. Nature itself has offered us a compound of this species. In fact, I have treated 10 grammes of gallnuts with 2 litres of boiling water, and although the residue had been washed with two litres more of very warm water, it still strongly reddened tincture of turnsole: in the gallnuts therefore the gallic acid is retained by a true affinity. But as the quantity of gallic acid abstracted by a spontaneous decomposition far exceeds the quantity of free acid existing in its natural state, we must conclude that the greatest part of the acid is certainly neutralized by the tannin. It is observed too, that if a decoction of gallnuts be allowed to follow its own course, as the tannin is destroyed, the liquor becomes more and more acid. One may, indeed, attribute this phenomenon to the transformation of the tannin itself into gallic acid; but numberless observations authorize us to believe that this is not the case.

1. That vegetable substances during their decomposition form no other acid but the acetic.

2. That

2. That gallnuts evidently contain abundance of gallic acid, and that, this acid having a strong affinity for tannin, the two bodies should necessarily neutralize each other in part.

3. Because there are many remarkable instances of the power of some vegetable substances to neutralize acids.

4. Lastly, that tannin precipitated from a decoction of gallnuts by an alkali or carbonate of ammonia, contains, according to my experiments, a good deal of gallic acid as well as a small portion of saline base. The proof I have of this is, that it produces with almost all the metallic solutions the same effects as gallic acid, or gallate of potash. Thus it gives red precipitates with solutions of the peroxides of mercury, blackish gray with solutions of peroxides of iron, a blue one to those less oxidized, the colour of wine lees (*lie de vin*) to those least oxidized. It follows then that we are not yet acquainted with the pure tannin of gallnuts, and of most other substances, and consequently that we know not how to act with them on metallic solutions, &c. Inquiries which have this object in view cannot but be interesting; and I propose to pursue them, in as much as they will on some future day allow me to bring forward the question-I am now treating of.

If, after having examined the vegetable substances which readily combine with acids, a search is made among animal substances endowed with the same properties, five will evidently occur: curdy matter, albumen, *picromel*, gelatin, and urea. This property is generally found in the curdy matter, as it is known that acids coagulate milk, that the coagulum contains an acid, and that this acid is even sensible to turnsole paper. Of course the affinity between those two bodies is well marked; yet it is not sufficiently strong to destroy all doubts to the contrary; for I am satisfied that the excess, and perhaps also the whole, of the acid may be abstracted by means of a large quantity of water.

If water alone be sufficient to take the acid from the curdy matter, it fails to produce the same effect when the acid is united to albumen; for the washings may be continued to an unlimited extent, and there will be always found acid undissolved.

We must conclude therefore, that this animal substance exerts on acids a more powerful attraction than the curdy matter; but this action varies in itself according to the concentrated state of the acid. As the acid is saturated with water, the results are combinations more or less insoluble,

soluble, and which again dissolve, the acid being saturated with ammonia, or with either of the other alkalis, and in which albumen is nowise altered. If on the contrary the acid is very strong and concentrated, the precipitates formed will always be acid, but will contain albumen in the state in which it exists when concentered by fire: this has appeared in treating the precipitates with a weak solution of ammonia. In the first instance, the solution will be gradually formed and complete; in the second; the acid alone will be taken up, and the albumen will remain undissolved in the form of a thick *magma*.

The combination of picromel with the acids took place with the same facility as with the preceding. Almost as soon as these substances come in contact, an acid precipitate is formed, which redissolves when neutralized. It is principally with the sulphuric, nitric, and muriatic acids that picromel forms slightly soluble compounds.

The concentrated nitric acid is the only one, according to Messrs. Fourcroy and Vauquelin, that precipitates urea from its solution in water; yet it is probable that the other acids are capable of combining with it; and if they do not precipitate it, it is because the compounds are soluble in water. I have observed that these combinations never form when the temperature is below 40 or 50, particularly with the sulphuric and muriatic acids; and that otherwise there is a disengagement of carbonic acid, and a production of a large quantity of ammonia.

Lastly, gelatin itself may unite with some acids, and principally with the oxy-muriatic acid. To effect this combination it is necessary to pass the gaseous acid through a solution of gelatin. In this operation the solution gradually becomes turbid and precipitates flakes, which unite together in the form of pearly filaments very elastic and flexible. These flakes have been considered by M. Bouillon-Lagrange, in a memoir upon the gizzards of birds, as the oxygenated gelatin*: but it is a mistake; they are really formed of gelatin slightly altered, and of the muriatic and oxy-muriatic acids. Their striking characteristics are, that they are insipid, insoluble both in water and alcohol, not liable to putrefy, slightly acid; though a sufficiently large portion of acid enters their composition to emit spontaneously for several days the oxy-muriatic acid gas, much more may be disengaged by means of heat: lastly, they contain so

* *Annales de Chimie*, tome lvi. p. 24.

much acid as to be soluble in alkalis, and to form with them muriates.

Thus we have examined five vegetable matters, and six animal matters, capable of an intimate union with acids. Three of the former, viz. alcohol, essential oil of turpentine, and a substance abounding in carbon, and produced from alcohol decomposed by oxy-muriatic acid, neutralize acids equally as well as the strongest alkalis. The last seven form with these acids combinations, which are themselves acid, like the metallic and most of the earthy salts.

Without doubt we shall in time be able to combine all other vegetable and animal substances with acids, and the experiments related allow even at present the inference to be drawn: for, if the combination cannot be made directly, no proof appears in this against what I advance. Does not alcohol, which in its ordinary state has not the property of neutralizing the vegetable acids, acquire it by the presence of a mineral acid? When these substances are placed in different circumstances, probably, the one best adapted to unite them with the acids will be found. These researches are laborious indeed; but they are useful and important, as tending to introduce us to the knowledge of a long compound series of a particular order; a knowledge which in itself must throw great light upon the analysis of vegetable and animal substances. In fact, is it not possible that we may find in organic bodies compounds of this kind? Are not gallnuts an example? Is it not possible that acetic acid, which we procure by the distillation of animal and vegetable substances, may be contained ready formed in some? Amber in particular, from which we get by distillation succinic acid, is it formed of an oily matter combined with succinic acid? The fatty substances which afford us sebacic acid, may they not also be in similar circumstances? Lastly, the bitter principle formed by treating animal substances with nitric acid, which acts as a very oxygenated body, although not acid; and the yellow acid, which, according to MM. Fourcroy and Vauquelin, is formed in the same operation, may they not be intimate combinations of an acid and of another matter? But it is above all things necessary, in the explanation of phenomena which pass before us, in the decomposition of vegetable and animal substances by acids, that a strict account should be kept of their tendency to unite with these bodies.

Thus we perceive that this general principle is susceptible
of

of a great many applications: we should endeavour therefore more and more to establish it, and it is my intention to attempt this in subsequent memoirs.

LXVI. *Experiments on Ammonia, and an Account of a new Method of analysing it, by Combustion with Oxygen and other Gases; in a Letter to HUMPHRY DAVY, Esq., Sec. R.S. &c., from WILLIAM HENRY, M.D., F.R.S. V.P. of the Lit. and Phil. Society, and Physician to the Infirmary, at Manchester.*

[Concluded from p. 375.]

II. *Experiments, in which Ammonia was fired with a deficient Proportion of Oxygen Gas.*

SIXTY-THREE measures of ammonia were exploded over mercury with 33 of oxygen gas containing one of nitrogen. The total, 96, when fired by an electric spark, were diminished to 57 measures, which were not contracted any further by successive agitation with water and with sulphuret of lime. The whole of the ammonia, therefore, was decomposed; and all the oxygen had entered into combination with the hydrogen of the alkali. The residuary 57 measures were mingled with 40 measures of the same oxygen gas, and detonated by an electric spark; after which the total, 97, were reduced to 60. The diminution, therefore, was 37 measures; and as two-thirds of this number may be ascribed to the condensation of hydrogen gas, the residuary 57 must have been composed of 24.66 hydrogen and 32.34 nitrogen. The oxygen expended also was 32 in the first combustion, + 12.33 in the second, = 44.33; and this number, being doubled, gives 88.66 for the whole hydrogen saturated, supposing it to be in the state of hydrogen gas. But from the above quantity of nitrogen (32.34 measures) we are to deduct one measure, with which the 33 measures of oxygen were contaminated; and the remainder 31.34 shows the number of measures of nitrogen resulting from 63 measures of ammonia. The total amount of gases obtained is $31.34 + 88.66 = 120$; and the proportion of the hydrogen by volume to that of the nitrogen, as 73.88 to 26.12.

To avoid the tediousness of similar details, I shall state in the form of a table, the results of a few experiments out of a number of others, all of which had, as nearly as could be

be expected, the same tendency. The sixth experiment in the table is the one which has been just described.

No. of Exp.	Meas. of Ammonia decomposed.	Meas. of Oxygen saturated.	Measure of Hydrogen estimated.	Meas. of Nitrogen obtained.	Hence 100 Meas. of Ammonia		Permanent Gas contains in 100 Measures.	
					Take Oxygen.	Give Gas.	Hydr.	Nitr.
1	72	47.5	95	37	66	183	72	28
2	95	64	128	46	67.5	183.3	73.5	26.5
3	100	72.2	144.4	54	72.2	198.5	72.8	28.2
4	74	51.7	103.4	37	69.8	189	73.6	27.4
5	49	33.7	67.4	25.3	68.7	180.2	72.7	27.3
6	63	44.3	88.6	31.3	70.3	193.5	73.9	26.1

From an attentive examination of the foregoing table, it will appear that the results are not perfectly uniform, though perhaps as much as can be expected from the nature of the experiments. Thus the proportion of permanent gases to the ammonia decomposed (the nitrogen being actually measured, and the hydrogen estimated by doubling the oxygen expended) may be observed to differ considerably; the highest product being $198\frac{1}{2}$, and the lowest 180.2 , from 100 of ammonia. There can scarcely be a doubt, however, that this want of coincidence is owing to the same cause as that which I have already assigned for the variable proportions of permanent gas, which are obtained from equal quantities of ammonia by electrization. And, accordingly, I have found that the evolved gases, as ascertained by combustion, bear the smallest proportion to the ammonia when most pains have been taken to obviate the presence of moisture. The lowest number, therefore, is to be assumed as most correct; but other circumstances being considered, I believe the second experiment furnishes the most accurate data for determining the composition of ammonia. The same explanation will apply to the different proportions of oxygen gas required for the saturation of 100 measures of ammonia, the variation no doubt arising from the uncertainty of the quantity of alkaline gas which is actually burned. The proportion of oxygen to ammonia, which I believe

believe to be nearest the truth, and most precisely necessary for mutual saturation, is that resulting from the second experiment, viz. $67\frac{1}{2}$ measures of oxygen gas to 100 of ammonia, or 100 of the former to 148 of the latter.

It may be observed, also, by comparing the numbers in the two last columns of the table, that the hydrogen and nitrogen gases do not uniformly bear the same proportions to each other. Notwithstanding all the labour I have bestowed on the subject, I have not been able to obtain a nearer correspondence, owing most probably to the imperfection of the mode of analysing a mixture of hydrogen and nitrogen gases. In the mixture of permanent gases, determined in this way, the hydrogen, it may be remarked, bears generally rather a less ratio than that of 74 to 26. I do not, however, consider this fact as contradicting the accuracy of the proportions which you have assigned; and it appears to me that a sufficient reason may be given for the want of a more perfect coincidence between results obtained by such different methods of investigation. In the products of the electrization of ammonia, the hydrogen composes nearly three-fourths of the mixture: and hence its combustion by oxygen gas is likely to be completely effected, and the whole of the hydrogen condensed into water. But after the *partial* combustion of ammonia by oxygen gas, a residuum is left of hydrogen and nitrogen gases, of which the hydrogen usually composes less, and sometimes considerably less, than one-half the bulk. In this case, it may be suspected that a small quantity of hydrogen occasionally escapes being burned; and whenever this happens, its proportion to the nitrogen will appear to be less than the true one*.

From the inflammability of a mixture of ammonia with oxygen gas, it was natural to expect that this alkali would prove susceptible of *slow* combustion. By means of a peculiar apparatus (on a plan which I have described in the Philosophical Transactions for 1808, Part II., but on a smaller scale, and with the substitution of mercury for water), I have found that ammonia, expelled from the orifice of a small steel burner, may be kindled by electricity in a vessel of oxygen gas; and that it is slowly consumed

* This consideration suggests the propriety of using no more oxygen in the first combustion of ammonia, than is barely sufficient to inflame it; or if a larger quantity has been used than is required for this purpose, and a residue consequently obtained, of which the hydrogen forms only a small proportion, it is proper to add a further quantity of hydrogen, before the second combustion. An allowance may afterwards be made for this addition.

with a pale yellow flame. The combustion, however, is not sufficiently vivid to render the process of any use in the analysis of ammonia.

With nitrous oxide (containing only 5 per cent. impurity) ammonia forms a mixture which is extremely combustible. If the nitrous oxide be in excess, the proportions have a considerable range; for any mixture may be fired by electricity, of which the ammonia is not less than one-sixth of the whole. The combustion is followed by a dense cloud, sometimes of an orange-colour. When the nitrous oxide greatly exceeds the ammonia, (as in the proportion, for example, of 100 to 30) there is little or no diminution after firing: and the residuum is composed of a small portion of undecomposed oxide, some oxygen gas, and a considerable quantity of nitrogen, the last of which, however, is not in its full proportion. When the nitrous oxide is further increased, still more oxygen is found in the residuum.

When, on the contrary, the alkaline gas is redundant, combustion does not take place unless the nitrous oxide forms one-third of the mixture. A little diminution takes place on firing, but no cloudiness is observed; and the residue is composed of hydrogen and nitrogen gases, with occasionally a small portion of undecomposed ammonia. As an example of what takes place, I select the following experiment from several others.

A mixture of 41 measures of ammonia, with 40 of nitrous oxide (= 38 pure), in all 81 measures, were reduced by combustion to 75, which were found to consist of 16 hydrogen and 59 nitrogen gases. To explain this experiment, we may assume (as is consistent with your own analysis*) that 100 measures of nitrous oxide are equivalent to 52 measures of oxygen gas and 103 of nitrogen. The oxygen in 38 measures of nitrous oxide will, therefore, be 19.7, to which, when the oxygen spent in burning the residuum (viz. 8 m.) is added, we obtain 27.7 for the total oxygen consumed; and multiplying by 2, we have 55.4 for the hydrogen saturated. From the residuary nitrogen (59) deduct 39 measures arising from the decomposition of the nitrous oxide + 2 m., mingled with it as an impurity = 41, and the remainder, 18 measures, is the nitrogen resulting from the volatile alkali; and as 41 measures of ammonia give 55.4 + 18 = 73.4 measures of permanent gas, 100 would give 179 measures, in which the hydrogen and nitrogen would exist

* Researches, Res. ii. Div. 1, or Thomson's System of Chemistry, 3d edit. ii. 143.

in the proportion of 75.4 to 24.6. From the same facts it may be deduced, that 100 measures of ammonia require for saturation 130 of nitrous oxide = $67\frac{1}{2}$ oxygen gas. The coincidence then, between the results of the combustion of ammonia with nitrous oxide, and those with oxygen gas, confirms the accuracy of both methods of analysis.

Nitrous gas, which, it appears from your testimony*, does not compose an inflammable mixture with hydrogen, (nor, as I am assured by Mr. Dalton, with any of the varieties of carburetted hydrogen) may be employed, I find, for the combustion of ammonia. The proportions required for mutual saturation are about 120 measures of nitrous gas to 100 of ammonia. An excess of the former gas does not give accurate results; since not only the hydrogen of the ammonia, but some of its nitrogen is also condensed; and the mixture, after being fired, exhibits the cloudy appearance usual in that case.

Forty-eight measures of ammonia, being fired with 60 nitrous gas, (= 53 pure) both gases were completely decomposed; and a residue left consisting of 61 nitrogen and 9 hydrogen. Sixty measures of ammonia and 41 nitrous gas (= 36.1 pure) gave, after firing, a mixture composed of 10 ammonia, $53\frac{1}{2}$ nitrogen, and $30\frac{1}{2}$ hydrogen. But taking for granted that 100 measures of nitrous gas, according to your analysis, hold in combination a quantity of oxygen equal to $57\frac{1}{2}$ measures of oxygen gas, and of nitrogen equal to $48\frac{1}{2}$ measures, and assuming the proportions of the nitrogen and hydrogen in ammonia to be those established by your experiments and my own; it will appear from an easy calculation, that the proportion of nitrogen, in the above residua, a little exceeds, and that of the hydrogen rather falls short of what might have been expected. I have not yet been able to reconcile these differences, by the numerous trials required in a process of so much delicacy; and I reserve the inquiry for a season of more leisure. The foregoing statement I wish to be considered as merely announcing the general fact of the combustibility of a mixture of ammonia and nitrous gas, a property which chiefly derives importance from its being capable of application to a new method of analysing the latter.

Before concluding this letter, I shall briefly state the results of some experiments, which I have lately made in conjunction with Mr. Dalton, on a subject that formerly oc-

* Recherches, p. 136.

cupied much of my attention; viz. the effect of electricity on the aëriform compounds of carbon and hydrogen. Subsequent reflection, as well as the candid and judicious criticisms of various writers*, have influenced me to doubt of the accuracy of a few of the conclusions drawn from my former inquiries †. The knowledge of this class of bodies has, also, been so materially advanced during the last twelve years, that the examination of their properties may now be undertaken with much greater confidence and success than formerly. It is to be lamented, indeed, that experimentalists do not oftener retrace their labours, with the combined advantages of acquired skill, and of a more improved state of the science which they investigate.

The gases, submitted by Mr. Dalton and myself to the action of long-continued electrization, were carburetted hydrogen from pit-coal of the specific gravity of about 650, (air being 1000) olefiant gas, and carbonic oxide. Each gas was used in as pure a state as possible; muriate of lime being first introduced into the same tubes in which the gases were electrified, and being withdrawn when it had exerted its full action. Platina wires were used to convey the electric discharges.

When the electrization of carburetted hydrogen or olefiant gases was continued sufficiently long, they were each found to expand, notwithstanding their extreme dryness. No carbonic acid could be discovered in the electrified gas by the nicest tests. When fired with oxygen, it gave less carbonic acid than the unexpanded gas, and required less oxygen for saturation. Calculating, from the diminished product of carbonic acid, how much gas had been decomposed by electrization, it appeared that the decomposed part, in all cases, was about doubled. The smaller product of carbonic acid from the electrified gas, was sufficiently explained by a deposition of charcoal on the inner surface of the glass tube, too distinct to be at all equivocal, and most abundant from the olefiant gas. No addition whatsoever of nitrogen was made by the electrization. It appears, therefore, that the hydro-carburetted gases, like ammonia, are separated by electrization into their elements,

* See Berthollet's *Chemical Statics*, Eng. trans. vol. ii. p. 454; Murray's *Elements of Chemistry*, vol. ii. note G; a letter from an anonymous correspondent in *Nicholson's Journal*, 8vo. ii. p. 185; and *Aikin's Dictionary of Chemistry*, i. p. 251.

† "Experiments on Carbonated Hydrogen Gas, with a View to determine whether Carbon be a simple or a compound Body." *Philosophical Transactions*, vol. lxxvii.

the carbon being precipitated, and the hydrogen evolved in a separate form, and acquiring a state of greater expansion. This change, however, is effected much more slowly than the disunion of the elements of ammonia.

From a portion of carbonic acid gas, carefully dried by muriate of lime, and electrized with platina conductors, we obtained, after removing the undecomposed gas by caustic potash, a residuum equal to about one-half the whole gas which had been employed. It was found on analysis to consist of oxygen and carbonic oxide gases, in such proportions as to inflame on passing an electric spark through it without any addition, and to be thus convertible again into carbonic acid. In the experiments of M. Saussure, jun.*, that ingenious philosopher obtained only carbonic oxide by the same operation, owing doubtless to the electricity having been conveyed by conductors of copper, which would become oxidized, and prevent the oxygen from being evolved in a separate form.

Carbonic oxide, electrified with similar precautions, did not appear to undergo any change. Eleven hundred discharges from a Leyden jar had no effect on a quantity of the gas, equal to about one-tenth of a cubic inch. Its bulk, after this process, was unaltered; no carbonic acid could be discovered in it; and there was no decided trace of oxygen gas in the residuum. The carbon, it appears, therefore, which exists in carbonic oxide, must be held combined by an extremely strong affinity.

With sincere esteem and respect, I am, dear sir,
your faithful and obliged friend,

WM. HENRY.

LXVII. *Proposal for an Institution for obtaining an equal Temperature in Houses.*

George Street, Hanover Square,
Dec. 25, 1809.

To Mr. Tilloch.

DEAR SIR,

WITH your approbation and in your presence I, some time ago, wrote hastily, and without any particular care in the composition, anonymously, an account of a project of an institution which I had long entertained, consisting of an extensive building, so constructed as to afford in every part an equal and summer temperature †. Of the great

* *Journal de Physique*, tome liv. p. 450.

† See *Phil. Mag.* vol. xxxi. p. 311.

advantages to be expected from such an institution for many disorders, particularly for that of pulmonary tubercles, I am assured, in consequence of the benefit procured by the comparatively rude contrivances I have employed for warming the rooms of our ill-adapted houses during the last 15 years: such as by means of large stone bottles filled with boiling-hot water, properly disposed, and assisted by double doors, double windows, &c. This plan I have not only constantly recommended to many hundred pupils, in my Lectures, but communicated to a number of persons, with the hope of exciting some of them to attempt to erect a fit establishment. No one more feelingly embraced the proposal than that great encourager of works of public utility, Sir John Sinclair. I put into his hands the plan of a building which, at his desire, had been drawn at my request, by the late Mr. Holland of Sloane Square, for the purpose now spoken of. Sir John mentions this project in his first tract *On Health and Longevity*, published, I think, in 1801. For a reason more interesting to myself than to the public, I beg leave to mention that I particularly recommended warm air as the most effectual means known of impeding the progress of pulmonary consumption, in a little communication to Dr. Duncan*. I believe, too, that the practice of warming rooms and regulating their temperature by the thermometer has been more frequent in this metropolis during the last four or five years than formerly.

In the proposed institution, so far from claiming any discovery of a new practice, it is not even pretended to be a revival: but it is judged from experience, that it has been employed only very limitedly and inadequately, in place of the very extensive and much more beneficial mode now intended.

I have much pleasure in acquainting you at this time, that a few days ago an architect of great celebrity, and to whom the British public owes many of its most useful works, assured me that he would shortly produce a grand plan for executing my design for the purposes of health, and conjoin a variety of comforts, and even some of the luxuries, of the hot climates.

I take this opportunity to offer my tribute of that respect which is due to you from every cultivator of science, for the very liberal and public-spirited conduct of your excellent periodical work, and to assure you that I am

your obliged friend,

GEORGE PEARSON.

* See the *Edinburgh Medical and Surgical Journal*, vol. i. p. 126, 1805.

LXVIII. *On Crystallography.* By M. HAUVY. Translated from the last Paris Edition of his *Traité de Minéralogie.*

[Continued from p. 358.]

OF THE REPRESENTATIVE SIGNS OF CRYSTALS.

THE relations which serve to connect the different ordinary crystals of one and the same substance with one common primitive form, are founded, as we have seen, on laws of structure whose effect is to determine the number and arrangement of the planes which compose the surface of each crystal. By a necessary consequence the naturalist, who is familiar with the progress of these laws, frequently finds it merely requisite to have before his eyes the primitive form, and the explanation of the decrements which its angles or its ridges undergo, in order to represent the polyhedron resulting from it, and to see in what manner, in idea, we may effect the metamorphosis of the nucleus from which this polyhedron is derived.

These considerations gave rise to an idea of translating into a very concise language, similar to that used in Algebra, the various laws which determine the secondary crystals, and thus to compose species of formulæ representative of these same crystals. It is sufficient, in order to attain this, to designate by letters the angles and ridges of the primitive form, and to accompany these letters by cyphers, which indicate the laws of decrements undergone by such angles and such ridges, and the result of which is a certain secondary form. I have endeavoured to confine the arrangement of the letters within a regular order, corresponding with that of the alphabet, so that this arrangement naturally presents itself to every one.

By attention to this point and some others concerning the manner of placing the cyphers, it requires, in my opinion, but a very few seconds to acquire the key of the method, and the principles which ought to serve as a rule for applying them will always remain impressed on the memory.

When we have traced and brought into a very narrow compass the different formulæ, which will be like the theoretical images of the crystals relative to one and the same substance, it will be equally easy to compare them, either with each other, or with the primitive form, which will also have its expression, to follow the transitions of the simpler to the more compound forms, to distinguish what they possess in common, and whatever is peculiar to each;—

in a word, to seize as if at one glance the diversity of the details and the unity of the whole.

Let us suppose that fig. 48 represents an oblique-angled parallelepipedon, the angles of which have different measurements, and which is the primitive form of a particular species of mineral, such as feldspar*.

Having adopted the vowels to designate solid angles in general, place the first four A, E, I, O, to the four angles of the upper base, following the order of the alphabet, and at the same time that of common writing, which is to begin at top and go from left to right. Vide fig. 49, in which the arrangement of the letters is rendered perceptible to the eye.

Having adopted the consonants to distinguish the ridges in general, place, according to the same rule, the first six B, C, D, F, G, H, on the middle of the sides of the upper base (fig. 48), and on the two longitudinal ridges of the lateral face which is first presented from right to left.

Finally, place on the middle of the superior base, and of the lateral faces situated in front, the three letters P, M, T, which are the initials of the syllables composing the word *primitive*.

Each of the four solid angles, or of the six edges designated by letters, is susceptible in the present case, on account of the irregular form of the parallelepipedon, of undergoing particular laws of decrements: let $A\rho$ (fig. 50) be the same parallelepipedon. If we compare the two solid angles diametrically opposite to O, r , it is easy to see that there is an equality between the plane angles which compose them, taken by pairs, viz.: 1st, between EOI and sru ; 2d, between $EO\rho$ and urA ; 3d, between $IO\rho$ and $s r A$. It results, that among the plane angles which are joined by three round solid angles A, O, there are only two which are equal, viz. EOI , IAE , as being opposite on one and the same parallelogram; but the angle $EO\rho$ is the supplement of the angle IAr , and the angle $IO\rho$ is that of $EA r$. In the same way the solid angles I, s are composed of equal plane angles two and two; but among the plane angles formed by the solid angles E, I, there are only AIO and AEO which are equal. Hence it follows, that the solid angle O being in a situation different from that in which the solid angle A is, and the same difference taking place with respect to the solid

* The parallelepipedon is considered as being represented in such a manner that the angle BAC which is the furthest from the observer, is one of the obtuse angles of the upper base.

angles I, E, each of these angles is, relative to crystallization, as it were, independent of that which corresponds with it diagonally. Finally, the ridges C and D, B and F, G and H, (fig. 48) compared with each other, are no longer in the same situation, because the two planes which unite upon one do not form between them the same angle with those which have the other for the line of junction. It is between these same ridges and those which are diametrically opposite to them; for instance, between A I and ps , (fig. 50) between A E and pu , &c., that there is a perfect equality.

By this we see why the four solid angles round the upper base, as well as the four edges of this base and the two longitudinal edges which are presented in front, are each of them marked with a particular letter. But as the laws of decrement act with the greatest possible symmetry, at least in general, every thing which takes place on one of the solid angles or of the edges designated, is repeated on the angle or the edge diametrically opposite, among those which have remained in vacuo. According to this, it was only necessary to designate the number of solid angles, or of ridges which undergo decrements really distinct, because these decrements contain implicitly those which take place on the angles or the analogous edges.

We are nevertheless sometimes obliged to indicate also these last angles or these last edges. Then we shall make use of small letters which bear the same names with the capital letters employed in fig. 48: for example, p (fig. 50) will be designated by a , sp by c , pu by b , &c. But it will be rarely necessary to make these small letters on the figure; it will be sufficient to make them enter into the sign of the crystal, because in imagination we can easily refer each to its proper place.

To indicate the effects of decrements by one, two, three, or more ranges, in breadth, we shall employ the cyphers 1, 2, 3, 4, &c., in the way to be immediately explained; and in order to indicate the effects of decrements by two and three ranges in height, we shall use the fractions $\frac{1}{2}$, $\frac{1}{3}$, &c.

The three letters P, M, T, will serve to designate either the form of the nucleus without any modification, when they will compose of themselves the sign of the crystal, or the faces which would be parallel to those of the nucleus, in the case of the decrements not attaining their limits, and then these letters will be combined, in the sign of the crystal,

crystal, with those which will have a relation to the angles or edges on which the decrements will act.

Let us suppose in the first place, for greater simplicity, that one of the solid angles, such as O , is intercepted by a single additional facet. The decrement to which we refer the production of this facet may take place either on the base P , or on the pane T which is to the right of the observer, or upon the pane M situated on his left.

In the first case, we shall place the index cypher above the letter; in the second we shall give to the cypher the place of a common exponent to the right and towards the top of the letter; and we shall indicate the third case by placing the cypher on the left, and even towards the top of the letter.

Thus $\overset{2}{O}$ will express the effect of a decrement by two ranges in breadth, parallel to the diagonal of the base P , which passes by the angle E ; O^3 the effect of a decrement by three ranges in breadth, parallel to the diagonal of the face T , which passes by the angle I , and 4O the effect of a decrement by four ranges, parallel to the diagonal of the face M , which passes by the angle E .

When the decrement has a reference to any of the three solid angles I , A , E , the observer is considered as turning round the crystal until he finds himself placed opposite this angle, as it was naturally opposite the angle O , in the case which we have described; or, what comes to the same thing, he is considered as turning the crystal, until the solid angle under consideration faces him, and it is with respect to this position that such a decrement is said to be towards the right or the left.

For example: if the solid angle A is in question, the sign A^2 will represent the effect of a decrement by two ranges on the face $A E s r$ (fig. 50), or upon that which is opposite to T (fig. 48), and 3A will represent the effect of a decrement by three ranges on the face $A I u r$ (fig. 50), or upon that which is opposite to M (fig. 48). We shall subsequently see the advantage of this manner of proceeding, relative to the uniformity of the method.

As to the decrements on the ridges, we shall express those which are formed towards the contour $B C F D$ of the base, by a number placed above or below the letter, according as their effect shall take place in ascending or descending, setting out from the ridge to which they will be referred; and those which are relative to the longitudinal ridges G, H , will be indicated by a sign placed either to the

the right or to the left of the letter, according as they shall take place in one direction or another.

Thus $\overset{2}{D}$ will express a decrement by two ranges, going from D towards C; $\overset{3}{C}$ a decrement by three ranges, going from C towards D; $\overset{2}{D}$ a decrement by two ranges, descending on the face M; $\overset{3}{H}$ a decrement by three ranges, going from H towards G; $\overset{4}{G}$ a decrement by four ranges, going from G towards the ridge opposite to H, &c.

In the case in which we should be obliged to designate by means of a small letter such as d , a decrement on the ridge ur (fig. 50), opposite to that which bears the large letter D (fig. 48), we should suppose the crystal to be turned upside down. Thus $\overset{2}{d}$ would express a decrement by two ranges ascending above the inferior base p , as $\overset{2}{D}$ would express one which is ascending on the upper base P. For the same reason $\overset{3}{c}$ would express a decrement by three ranges proceeding from sp (fig. 50) towards E O.

If the same solid angle or the same ridge undergoes several successive decrements on the same side, or several decrements which take place on different sides, we shall repeat the same number of times the index letter, varying the cyphers conformably to the diversity of the decrements.

Thus $\overset{2}{D}$ will designate two decrements on the ridge D, the one by two ranges ascending on the base P, the other by three ranges descending on the face M. $\overset{2}{H}$, $\overset{4}{H}$ will designate two decrements, the one by two ranges, the other by four, to the left of the ridge H, &c.

If there are mixed decrements, we shall indicate them on the same principles, by employing the fractions $\frac{2}{3}$, $\frac{3}{4}$, &c., which represent them, and the numerator of which refers to the decrement in breadth, and the denominator to the decrement in height.

It now remains to find a method of representing the intermediate decrements. An example will show that which we have adopted. Let A E O I (fig. 51) be the same face with fig. 18. Let us suppose a decrement by one range of double molecules, following parallel lines xy , so that O y measures double lines by one ridge of molecules, and O x lines simply equal to this ridge. We shall thus indicate this decrement (O D¹ F²). The parenthesis shows in the first place that the decrement is intermediate; O indicates that

that it takes place by one range on the angle marked by the same letter, and that it refers to the base A E O I (fig. 48.). D¹ F² indicate that for one single ridge of molecules subtracted from the length of the side D, there are two ridges subtracted along the side F.

It is useful to have a language for pointing out these different signs, so that they can easily be written to dictation. We can announce the signs O², ³O, by saying, O two on the right, O three on the left: in order to announce $\overset{2}{O} O$, we shall say O under two, O above four:

lastly, the sign ($\overset{1}{O} D^1 F^2$) will be thus announced, *within parenthesis, O under one, D one, F two.*

We shall give an example of the combination of these different signs, in the expression of a compound crystalline form. But we must previously determine the order according to which the letters ought to be arranged which concur in one and the same expression. Now if we adopted the order of the alphabet, a kind of confusion would result in the table presented by the formula. It seems more natural to conform to the order which would direct an observer even in the description of the crystal, *i. e.* to commence by the prism or by the middle part, and indicate its different faces as they are successively presented to the eye, then passing to the faces of the summit or of the pyramid. This will be elucidated by the various examples to be cited in the course of this article.

Let us now suppose that fig. 52 represents the variety of feldspar, called *bibinary*, the primitive form of which is seen in fig. 48. In this variety, the pane l (fig. 52.) results from a decrement by two ranges on the ridge G (fig. 48.) going towards H; the pane M (fig. 52.) answers to that which is marked with the same letter (fig. 48.), and which is only partly concealed by the effect of the decrement. The pane T (fig. 52.) is parallel to T (fig. 48.); the pentagon x (fig. 52) proceeds from a decrement by two ranges on the angle I (fig. 48.) parallel to the diagonal which goes from A to O: lastly, as this decrement no longer attains its limit, the summit bears a second pentagon P (fig. 52.) parallel to the base P (fig. 48). All this description may be thus translated into five letters G² M T I P.

I confined myself in the first place to give the pure and simple expressions of the indicative signs, similar to those which we have seen. But I afterwards perceived that I could not take too many precautions, in order to free this language,

language, already extremely concise, from every thing enigmatical, and because in the case particularly when the form was composed of a great number of facets, which would necessarily imply a proportional complication in the expression of the sign, beginners would be embarrassed to make the relation between one and the other.

To obviate this difficulty, I thought it right to place under the different letters which compose the sign, those which correspond with them on the figure. By means of this addition the sign of the binary feldspar is presented as follows: $G^2 M T I P$. This is the method which I shall use in the course of this work, with respect to all the crystalline forms, adding to each sign a kind of guide, which will serve for recovering its form, however complicated it may be.

We shall pass to the parallelopipedons of a more regular form, and in the first place consider the cases in which they differ from the rhomboid. We shall suppose that each of them is nothing else than that of fig. 48; the form of which has varied so as to become more symmetrical. As a consequence of this variation, certain solid or salient angles, which were different on the first parallelopipedon, have become equal. All that takes place on one is repeated on the other, and they consequently ought to be marked with the same letter. It is thus that, in algebra, certain general solutions are simplified in the particular cases where a quantity, which we had at first supposed different from another law, becomes equal.

Let us conceive, for example, that the primitive form is a straight prism, which has for bases oblique-angled parallelograms, one side of which is longer than the other. We shall have (fig. 49.) $O=A$, $I=E$, &c. We shall substitute, therefore, on both occasions, the second letter for the first, as we see on fig. 53.

By continuing to run over the various modifications of the parallelopipedon, we shall see them pass by different degrees of simplicity, which will determine new equalities between the letters indicative of their angles and of their edges; and we shall have successively,

For the oblique prism with rhombic bases, the expression represented in fig. 54.

For the straight prism with rectangular bases, that which we see in fig. 55.

For the straight prism with rhombic bases, that of fig. 56.

For

For the straight prism with square bases, that of fig. 57, Pl. VII.

Finally, for the cube, that of fig. 58. Here we have only designated the superior base by letters, because we may apply to the one any of the other faces, which takes place with respect to that base.

We shall follow, with respect to all these different primitive forms, a method of cyphering analogous with that which we have adopted for the oblique-angled parallelogram of fig. 48, by dispensing with a repetition of the letters of the same word cyphered in the same manner.

An example will show this method. Fig. 59. represents the most common variety of the cymophane, the nucleus of which is a rectangled parallelepipedon as we see it in fig. 55. The sign of the secondary crystal will be $MT^2GG^2BA^{\frac{3}{2}}A$. I have named this variety *annular cymophane*.

That we may better seize the course which has led us to the foregoing expression, we shall indicate all the angles by as many particular letters, as if the parallelepipedon was an oblique angle. See fig. 60. The sign will become $MT^2GH^2BFE^{\frac{3}{2}}O$. But on comparing fig. 60. with fig. 55. we find that $H=G$, $F=B$, $O=A$, &c. By thus substituting, instead of the first letters, their values, we shall have $MT^2GG^2BA^{\frac{3}{2}}A$, which returns to the expression indicated above, suppressing the useless repetition of B .

It results from the above, that we must avoid confounding, for instance $^2GG^2$ with G^2^2G . The first sign indicates decrements which take place on the face T (fig. 55) and upon that which is opposite to it, going from the ridges G towards those corresponding with them behind the parallelepipedon; the second designates decrements which take place on the face M going to the meeting of both. If the two decrements took place simultaneously, their representative sign would be $^2G^2$.

In the foregoing signs, every letter, such as 2G or G^2 , can only be applied to a single ridge, situated like this letter itself, to the right or the left. But $^2G^2$ is applied indifferently to both ridges; it is therefore of no use to repeat this letter.

We shall give a new example drawn from the distich topaz (fig. 61). If we suppose that fig. 56. represents the primitive form, which is a straight prism with rhombic bases, we shall have for the sign of the variety in question

$^3G^3M^2B^2B^2E^2E^2P$.

• M T 1 2 4 P

In this sign the quantity ${}^3G^3$ indicates two distinct faces, which are formed on both sides of each ridge G (fig. 56). But it is not necessary to place two letters under this sign, because, all the faces situated in the same manner being designated by the same letter on the figure, it is sufficient that the sign ${}^3G^3$ refers to the marked faces of the letter o , which requires only that this letter should be written once under the sign.

We shall easily conclude from the same principles, that the dodecahedron with rhombic planes originating from the cube (fig. 58) is expressed by this single letter $\overset{1}{B}B$, that the octahedron originating from the same nucleus has for its sign $\overset{1}{A}{}^1A^1$, &c.

The rhomboid, by supposing it placed under the most natural aspect, *i. e.* in such a manner that the two solid angles, composed of three equal plane angles, are on one and the same vertical axis, has not properly bases, but merely two summits, which are the extremities of the axis. We shall designate its angles and ridges as in fig. 62. The letter e makes known that the angle which bears it is similar to that marked with the larger letter; so that if all the lateral angles had their indications expressed, the three nearest the upper summits would bear the letter E ; and the three which adjoin the lower summits, and which are diametrically opposite to the first, would have e as their indicative letter.

As the rhomboid has its six faces equal and similar, it is only necessary to consider the decrements relative to one of the faces, as that which on the figure bears the letter P , because all the rest are merely the returns of this. This being done: 1st, the decrements which set out from the upper angle A or from the upper edge B will have their indicating cypher placed below the letter A or B ; 2d, those which set out from the lateral angles E will have their cypher situated on one side, towards the top of the same letter; 3d, with regard to those which set out from the lower angle e , or from the lower edge D , the cypher destined to express them will be placed above the letter e or D .

Let us suppose, for example, that fig. 63. represents analogical carbonated lime already mentioned: we shall have the following sign $\overset{2}{e} \overset{2}{D} \overset{1}{B}$, the interpretation of which is easy, from combining the letters which indicate the faces with those which express the decrements of which these same faces are the result.

What

What has been said relative to the parallelipedon is of itself applicable to the other primitive forms. We shall go over them successively.

Fig. 64. represents the expression of the octahedron with scalene triangles; fig. 65. that of the octahedron with isosceles triangles, and fig. 66. that of the regular octahedron.

In order to place the cyphers which accompany the letters, we shall conform to what has been said relative to the rhomboid. Thus in fig. 65. we shall place the cypher below, for the decrements which set out from the angle A or from the ridge B; above, for those which set out from the ridge D; and on one side for those which set out from the angle E.

If we wished to designate the result of a decrement by one range on all the angles of the regular octahedron (fig. 66.), we should write A¹A¹; and in order to indicate the result of a decrement by one range on all the edges, we should write B¹B. The first of these decrements produces a cube, and the second a dodecahedron with rhombic planes.

In some species, such as nitrated potash, the primitive octahedron, the surface of which is composed of eight isosceles triangles four and four similar to each other, ought to have the position represented in fig. 67., in order that the secondary crystals may be in the most natural attitude, *i. e.* that the ridges at the junction of the two pyramids which compose the octahedron ought to be partly in the vertical direction like F, and partly in the horizontal direction like B. On comparing fig. 67. with fig. 68., in which we have acted by placing the letters as if all the angles and all the ridges had particular functions, we shall easily conceive the distribution adopted in fig. 67., and reduced to the symmetry of the true primitive form: for in the present case we have E=A, D=C, G=F.

We shall place the index cypher below the letter, with respect to decrements which set out from B; on one side or below with respect to such as set out from A, according as their effect shall be referred to the triangle A I A or to the triangle A I F; above or below with respect to those which set out from C, according as their effect shall take place in the same way on the first or on the second triangle; on one side with respect to the decrements which set out from F; above and below, or on both sides, for the decrements which set out from I, according as their effect shall be directed towards B or towards F.

The tetrahedron being always regular, when it becomes the primitive form, its expression will be represented fig. 69.

In

In order to indicate, for example, a decrement by three ranges on all the edges, we shall take B^3B ; and in order to designate one by two ranges on all the angles, we shall take A^2A^2 , as in the case of the regular octahedron.

² A single glance at fig. 70. will be sufficient to give an idea of the designation of the regular hexahedral prism in ordinary cases; and as to the manner of placing the cyphers, we shall not detain our readers a moment, because it is easily deduced from that which we have adopted with respect to quadrangular prisms.

But it sometimes happens that three of the solid angles taken alternately are replaced by facets, while the intermediate angles remain untouched. In this case the expression of the prism will be that which we see in fig. 71.

In the rhomboidal dodecahedron (fig. 72, Plate VIII.) each solid angle composed of three planes may be assimilated to an obtuse rhomboidal summit; and thus we shall confine ourselves to decyphering a single face, as the figure represents.

Hitherto we have not been in the habit of employing the sign of the dodecahedron with isosceles triangular planes because it is more natural to substitute in its stead, as a primitive form, the rhomboid from which it is derived, and which gives still more simple laws of decrement.

It remains to make known the method of representing a particular circumstance which occurs in some crystals, in which the parts opposite to those which undergo certain laws of decrement remain untouched, or are modified by different laws. This circumstance particularly applies to tourmalines, and it is then easy to indicate the difference by means of zeros. For example, in the equidifferent tourmaline represented in fig. 74., and of which we see the rhomboidal nucleus (fig. 73.), the prism which is enneagonal has six of its panes, viz. s, s (fig. 74.) produced by subtractions of one range on the ridges D, D (fig. 73.); and the three others, such as t , by subtractions of two ranges solely on the three angles e . Moreover, the lower summit has simply three faces parallel to those of the nucleus, while on the upper summit the three ridges B are replaced each by a facet n, n (fig. 74.) in virtue of a decrement which does not attain its limit. The following is the representative sign of this form. $D^1e^2EP^2Bb$. The quantities

E, b make known, the one of them, that the angles

E (fig. 73.) opposite to *e* undergo no decrement ; the other, that the ridges opposite to B remain in a similar manner unaltered.

[To be continued.]

LXIX. *Notices respecting New Books.*

MR. T. LEYBOURN, of the Royal Military College, has just published the ninth number of his periodical work, entitled *The Mathematical Repository*: it contains, besides various articles, solutions of mathematical questions proposed in the seventh number, and a series of new questions, to which he solicits answers from his correspondents, with a view to their being inserted in the eleventh number. In publishing this work the editor has in view to promote the study of the various branches of the mathematics, by affording to the student an opportunity of cultivating his powers of invention in resolving problems which depend on its different theories ; and also to collect together and preserve the fruits of the studies of his ingenious correspondents, among whom he includes some of the most skilful mathematicians in this country. The number here announced completes the second volume of the work ; and as some account of the contents of both volumes may not be unacceptable to such of our readers as cultivate the science of which they treat, we shall briefly enumerate them.

Vol. I. part 1st, consists of one hundred and twenty questions, both in pure and mixt mathematics, almost all of which are entirely new, and, in general, each is accompanied with several solutions by different mathematicians. Part 2d, consisting of ORIGINAL ESSAYS, comprehends the following articles:—1. Demonstrations of some propositions relating to such portions of the surface and solidity of a sphere as may be exactly squared and cubed, by Mr. Ivory.—2. Demonstration of a theorem, respecting prime numbers, by Mr. Ivory.—3. Tagnani's theorem respecting elliptic arches, rendered more general, by Mr. Ivory.—4. A geometrical porism, with two examples of its application to the solution of problems, by Scoticus.—5. Geometrical propositions, by Mr. Ivory.—6. Solution of a dynamical question, by Mr. Ivory.—7. Of the equilibrium of a very long and slender cylinder floating in a fluid, by Jac. Rube.—8. Of the length of an arc of a circle in terms of the tangent, by Mr. Benjamin Gompertz.

—9. Geo—

—9. Geometrical porisms, by Mr. Noodle.—10. Diophantine problems, by Mr. Cunliffe.—11. Problems relating to the twilight of shortest duration, by Astronomicus.—12. Certain fluents expressible by an elliptic arch, by Mr. Cunliffe.—Part 3d is composed of MATHEMATICAL MEMOIRS extracted from works of eminence, and contains, 1. Solutions of some problems relative to spherical triangles, together with a complete analysis of these triangles, by La Grange. From *Journal de l'Ecole Polytechnique*.—2. An Essay on numerical analysis and the transformation of fractions, by the same author, and from the same work.—3. On the inverse method of central forces, by Mr. John Dawson. From the Manchester Memoirs.

Vol. II. part 1st, consists of a hundred and twenty questions, each with several answers. Part 2d contains the following original articles:—1. Demonstration of a proposition in mechanics, by A. B.—2. On the motion of pendulums whose points of suspension are moveable, by Mr. Gough.—3. An ocular demonstration of the forty-seventh proposition of the first book of Euclid, by Mr. Douglas.—4 and 5. On the sums of certain infinite series, by Mr. Cunliffe.—6. Solution of a dynamical question, by Mr. Barry.—7. Some properties of parallelograms, with the application of them to the moments of forces, by Mr. Gough.—8. Solutions of some mechanical problems, by A. B.—9. A diophantine problem, by Mr. Cunliffe.—10. The theory of amicable numbers, by Mr. Gough.—11. A new solution of a problem in insurance of money on lives, by Philalethes Cantabrigiensis.—12. To find the sums of certain infinite series, by Mr. Cunliffe.—13. On the attraction of an infinite solid elliptic cylinder, by Mr. Knight.—14. Two indeterminate problems, by Mr. Cunliffe.—15. On the proportionality of the force to the velocity, and on the composition of forces, by Mr. Knight.—16. On the composition of rotatory motions, by Mr. Knight.—17. On the expansion of certain functions, by Mr. Knight.—18. On the expansion of any function of a multinomial, by Mr. Knight.—19. Demonstration of a theorem, in the diophantine analysis, by Mr. Barlow.—20. Mr. Knight on the binomial theorem.—21. A dynamical principle, with some examples, by Mr. Barley. Part 3d contains a memoir on elliptic transcendentals, by Le Gendre. Read to the ci-devant Academy of Sciences in April 1792.

We understand that the first volume of the Transactions

of the Wernerian Natural History Society is in the press, and will appear early in the ensuing year; and also that Dr. Charles Anderson of Leith, the learned translator of Werner's classical work on Veins, has now in the press a translation of the celebrated Von Buch's mineralogical description of the county of Landeck in Silesia. Daubuisson, a distinguished pupil of the illustrious Werner, sometime ago published an excellent description of the Flætz-trap formation of Bohemia; and it gives us pleasure to announce that a translation of that work, by a member of the Wernerian Society, is nearly finished, and will appear early in the ensuing spring.

LXX. *Proceedings of Learned Societies.*

ROYAL SOCIETY.

Nov. 30.—This being St. Andrew's Day, the Society held their anniversary meeting at their apartments in Somerset place, when the President, the right hon. Sir Joseph Banks, Bart. K. B. in the name of the society, presented the gold medal (called Sir Godfrey Copley's) to Mr. Edward Troughton, for the account of his method of dividing astronomical instruments, printed in the last volume of the Philosophical Transactions. In the president's address on delivering the medal, he took occasion to observe, that since the last anniversary a new Society had been instituted for the purpose of "improving animal chemistry;" that this society considered itself as a child of the Royal Society, to which it looked up as a patron and protector; that all the papers communicated by its members, or others, were to be submitted to the council of the Royal Society, and if approved of to be read and published in the Philosophical Transactions; and finally, that whilst the Royal Society continued to be the channel by which such papers were widely circulated, the advantage of forming select bodies for the investigation of particular subjects must contribute to extend our knowledge in all the various branches of science, and carry them rapidly to a state of perfection to which the isolated labours of individuals could not hope to attain.

Afterwards the Society proceeded to the choice of the council and officers for the ensuing year; when, on examining the ballots, it appeared that the following gentlemen were elected of the council:—

Of

Of the old Council.—The right hon. Sir Joseph Banks, bart. K. B. Edward Ash, M. D. Sir Charles Blagden, knt. Samuel Goodenough, lord bishop of Carlisle, Henry Cavendish, esq. Humphry Davy, esq. William Marsden, esq. Rev. Nevil Maskelyne, D. D. George earl of Morton, Sir John Thomas Stanley, bart. William Hyde Wollaston, M. D.

Of the new Council.—Jame Brodie, esq. Robert Lord Carrington, Richard Chenevix, esq., Thomas Lord Dundas, Rev. Henry Fly, D. D. Mr. Stephen Lee, William George Maton, M. D. George Shaw, M. D. James Smithson, esq., George Holme Sumner, esq.

And the officers were the right hon. Sir Joseph Banks, bart. K. B. president; William Marsden, esq. treasurer; William Hyde Wollaston, M. D. Humphry Davy, esq. secretaries.

The members of the Society dined together, as usual, after the election, at the Crown and Anchor Tavern, Strand.

Dec. 7, 14, and 21.—In the third section of the Bakerian lecture, Mr. Davy detailed a number of laborious and minute experiments on the circumstances under which nitrous acid and ammonia are produced. He showed that nitrogen is not formed by the electrization of pure water, and that in most of those cases in which it appears it pre-exists in some compound employed in the process:—the facts in favour of the composition of nitrogen are those derived from the electrical experiments upon the amalgamation of ammonia, and those derived from the action of potassium upon the same alkali. Mr. Davy brought forward various new facts and reasonings in support of the opinion that ammonia is an oxide.

In the fourth section several experiments upon the earths are detailed; Mr. Davy has succeeded in decomposing silica, alumina, and glucine, by means of potassium and iron, and has obtained amalgams of the metals of magnesia and lime by mere chemical agency. Potassium is sent in vapour through the earths ignited to whiteness, and mercury is passed into the tube, which unites to the new metals.

In the fifth section Mr. Davy compares the antiphlogistic hypothesis of the nature of metallic bodies, with a modified phlogistic hypothesis, that they may be compounds of unknown bases with hydrogen; and he states that the decision upon these important points of doctrine cannot be made, till perfectly correct notions upon the nature of ammonia, nitrogen, and hydrogen are acquired.

Amongst other combinations before unknown, which

Mr. Davy describes in this lecture, is a new inflammable gas composed of the boracic basis and hydrogen.

WERNERIAN NATURAL HISTORY SOCIETY.

The first meeting of the third session of this Society was held in the College Museum at Edinburgh on the 4th of November last. There was then read a learned botanical paper, by Mr. R. Brown, of London, proposing a subdivision of the Apocinæ of Jussieu, to be called *Asclepiadeæ*; the first part of a paper on meteoric stones, by Mr. G. S. Hamilton; and the concluding part of an account of the fishes found in the Frith of Forth, by Mr. Neill.

The next meeting was on the 9th of December, when professor Jameson read an account of a considerable number of animals of the class Vermes, which he had observed on the shores of the Frith of Forth, and the coasts of the Orkney and Shetland Islands; and also a series of observations on the different precious stones found in Scotland; particularly the topaz, of which he exhibited a series of interesting specimens from Aberdeenshire, and among these was a crystal weighing nearly eight ounces, which is probably the largest crystallized specimen hitherto discovered in any country. The secretary laid before this meeting a communication from the rev. Mr. Fleming of Bressay, describing several rare Vermes lately discovered by him in Shetland; and a catalogue of rare Plants to be found within a day's excursion from Edinburgh, by Mr. R. Maughan, sen. At this meeting the following gentlemen were chosen office-bearers for 1810: Professor Jameson, president; Drs. Wright, Macknight, Barclay and T. Thomson, vice-presidents: P. Walker, esq. treasurer: P. Neill, esq. secretary: P. Sime, painter.

LXXI. *Intelligence and Miscellaneous Articles.*

WERNER has had the distinguished honour conferred on him of being elected one of the honorary fellows of the Royal Society of Edinburgh; and also honorary member of the Royal Medical, Royal Physical, and Natural History and Chemical Societies of Edinburgh, and of the Literary and Philosophical Society of Manchester.

Tuesday, Dec. 26, died at his house in Wells Street, Oxford Street, Tiberius Cavallo, esq. F. R. S. &c., and author of several valuable scientific works.

LECTURES.

Mr. Taunton will commence his spring course of lectures on anatomy, physiology, pathology, and surgery, on Saturday, January 27, 1810, at eight o'clock in the evening precisely. The lectures will be continued every succeeding Tuesday, Thursday, and Saturday, at the same hour, until the completion of the course.

The structure and œconomy of the living body, with the causes, symptoms, nature, and treatment of surgical diseases, and the modes of performing surgical operations, will be successively described in the course of the above lectures; besides which an ample field for professional acquirements will be opened, by the opportunities afforded to the student of attending the clinical and other practice of the City and Finsbury Dispensaries, to which Mr. Taunton is surgeon.

Particulars may be had on applying to Mr. Taunton, Greville Street, Hatton Garden.

LIST OF PATENTS FOR NEW INVENTIONS.

To John Brown, of Mile End New Town, Middlesex, stationer, for certain improvements on a machine or press for letter-press printing; and also for printing various ornaments and figures; part of which improvements may be applied to presses now in use.—Nov. 28, 1809.

To William Cornelius English, of Twickenham, Middlesex, esq., for his method whereby heated water, steam, and air, can be rendered serviceable; and more serviceable for new purposes, and every purpose for which they have ever been applied, with less expense of fuel than is now used, especially for the purpose of working the steam-engine, and of warming and heating buildings and stoves; and also vessels and coppers for all purposes, and by which water, steam, and air (heated) may be applied to many purposes.—Nov. 28.

To Thomas Herbert, officer of the customs, at Malden, in Essex, for a rotative pump, or engine for raising and forcing air, water, and other fluids.—Nov. 28.

To James Barrow, of Wells Street, Middlesex, brass-founder, for an improvement on the apparatus used for rollers for window blinds, maps, and other similar objects.—Dec. 5.

To George Ware, of the royal military academy, Woolwich, gent., for his apparatus and machinery for the sup-
port

port and exercise of the human frame, and for the prevention of bodily deformity.—Dec. 5.

To Samuel Felton, of Berwick Street, Soho, botanist, for his botanical or medicinal preparation; being a remedy for gravel and stony concretions, which he denominates “Mucilage of Marshmallows.”—Dec. 9.

To John Jones, of Manchester, cotton-spinner, for his new sort of instrument, or machine for preparing and cutting cotton and lin candlewicks.—Dec. 9.

To John Manton, of Dover Street, Middlesex, gun-maker, for an improved lock for guns and pistols.—Dec. 11.

To John Murray, of Nicholson’s Street, Edinburgh, esq., and Adam Anderson, of South Bridge Street, Edinburgh, tin-plate workers, for a portable stove, or furnace, which may be made of cast-iron, forged or plate iron, or of other metals or materials, by which a current of air is heated, and discharged so as to distribute the heat more equally than by stoves such as are in common use, and avoid the unpleasant smell which they produce; and which air, if necessary, may be brought from the external atmosphere, so as to produce ventilation as well as warmth. That a stove of this construction may be usefully applied in warming and ventilating churches, public rooms, halls, stair-cases; and by means of tubes connected with it the apartments of houses; and will also be useful to ventilating and heating ships and manufactories, drying different articles of manufacture, ventilating mines, and for other purposes.—Dec. 14.

To John Duff, of Great Pulteney Street, cutler, for an invention of snufflers on a new and improved construction, communicated to him by a foreigner.—Dec. 14.

To Mark Noble, of the parish of Battersea, Surrey, engine-maker, for an improvement on chain and hand pumps, and a new invented fire-extinguishing engine and steam engine.—Dec. 14.

To Charles Fred. Davis, of the parish of Itchcombe, in the county of Gloucester, clothier, for his improvement in the manufacture of woollen stocking pieces, by raising and producing on his improved manufacture a nap or pile in resemblance of kersymere and broad cloths. And also an improvement on the manufacture of kersymere and broad cloths, by means of transverse elasticity given to his manufacture, equal in use from its ease to the woollen stocking manufactures.—Dec. 20.

METEOROLOGICAL TABLE,
 BY MR. CAREY, OF THE STRAND,
 For December 1809.

Days of the Month.	Thermometer.			Height of the Barom. Inches.	Degrees of Dryness by Leslie's Hygrometer.	Weather.
	8 o'Clock, Morning.	Noon.	11 o'Clock, Night.			
Nov. 27	32°	41°	35°	29·75	5	Cloudy
28	35	39	35	·87	0	Small rain
29	35	40	36	·84	0	Small rain
30	32	42	39	·75	5	Cloudy
Dec. 1	41	43	36	·31	21	Fair
2	32	41	33	·72	18	Fair
3	37	43	43	·56	15	Fair
4	43	58	37	·41	20	Fair
5	35	43	37	·95	26	Fair
6	46	49	47	·92	6	Cloudy
7	47	49	40	·95	10	Stormy
8	40	44	41	30·02	24	Fair
9	46	49	46	29·40	7	Showery
10	46	48	44	·19	16	Fair
11	40	43	39	·45	24	Fair
12	42	47	39	28·95	10	Stormy
13	38	42	39	29·18	7	Stormy
14	33	39	41	·41	10	Fair. Violent storm at night
15	40	42	36	28·80	5	Showery
16	33	38	38	·80	5	Fair
17	38	39	40	·31	0	Small rain
18	40	40	40	·50	0	Rain
19	40	44	40	29·30	15	Cloudy
20	39	44	38	·70	18	Fair
21	38	43	38	·78	18	Fair
22	38	43	40	·90	5	Fair
23	35	39	36	·89	6	Foggy
24	35	39	39	·79	0	Small fall of snow
25	35	41	40	·90	5	Cloudy
26	39	40	40	·82	0	Rain

N. B. The Barometer's height is taken at one o'clock.

INDEX TO VOL. XXXIV.

- ACADEMY of Sciences**, Copenhagen 76
- Acetate of Lead**. New medicinal properties of 129
- Acetic acid** from wood 235
- Acetic ether**. On 153
- Acids**, *Boracic*, Davy on, 113; *Fluoric*, Davy on, 120; *Muriatic*, Davy on, 181, 409; *Acetic*, obtained from woods, 235; difference between *muriatic* and *oxymuriatic*, 409; action of vegetable acids on alcohol, 431; combination of, with animal and vegetable substances, 439
- Acrolites**. On, 151
- Aerostation**, 76, 78
- Agriculture**, 313
- Alcohol analysed**, 152
- Allen and Pepys**. On respiration, 379, 415
- American Indians**, Cosmogony of, 261
- Ammonia**. Davy on, 6, 339, 393; Henry on, 369, 447
- Amphibious reptiles**, 147
- Analysis**, of sulphur, 12, 405; *Mécanique Céleste*, 36; phosphorus, 108, 405; plumbago, charcoal, and diamond, 110; boracic acid, 113; fluoric acid, 120; milt of fishes, 151; human bones, 151; alcohol, 152; ether, 152; malleable iron, 153; new means of, 236; of ammonia, 339
- Anatomy**, 43, 143, 303
- Andreoli's aerial voyage**, 78
- Anemometer**, Kirwan's, 247
- Animal Chemistry**, 151, 302, 468
- Animal remains, fossil**, 309
- Animal substances**, combined with acids, 439
- Astronomy**, 36, 70, 202, 227, 229, 241, 252
- Atmosphere**. A prize question, 76
- Bakerian lecture**. Davy's, 6, 108, 181
- Banks's** (Sir J.) circular respecting Merino sheep, 155
- Beet-root**, a substitute for coffee, 316
- Biot**, on sounds in vapours, 277
- Biol's analysis of Mécanique Céleste**, 36, 202, 252
- Blanchard's rain-table**, 158
- Bleeding, internal**, remedy for, 129
- Books, New**, 146, 303, 391, 466
- Boracic acid**. Davy on, 113; decomposition of, 113
- Boracium**, the metallic base of boracic acid, 120
- Botany**, 31, 149, 306, 313, 394
- Breams**, to breed, 270
- Brewster's new instruments**, 77
- Brioschi's aerial voyage**, 78
- Brodie's dissection of a singular human foetus**, 43
- Brogniart on fossils**, 310
- Broom**. Flax from, 378
- Caisson**, floating, made of iron, 378
- Carey's meteorological tables**, 80, 160, 240, 320, 398, 473
- Carps**, to breed, 271
- Carr on geology**, 19, 137, 190; Reply to, 49; on eels, 272; on salmon-leaps, 321
- Carrots** a cure for ulcers, 281
- Cat**. Singular fact respecting, 347
- Champignons**. Poisonous effects of, 395
- Charcoal**. Davy on, 110
- Children on Voltaic electricity**, 26
- Children**. On marks on, 347
- Ciladri's clavi-cylinder**, 315
- City philosophical society**, 237
- Clark's meteorological table**, 159
- Clavi-cylinder**. A new musical instrument, 315
- Clegg's steam-engine**, 401
- Clocks**. E. Walker on pendulums of, 3
- Cochrane on sea currents**, 156
- Coffee**. Substitute for, 316
- Colours found in Pompeia**, 411
- Coloured rings**. On Herschel's, 359
- Cosmogony of the Canada Indians**, 261
- Cray-fish**. To breed, 332
- Crocodile**. On the varieties of, 147
- Croonian lecture**. Wollaston's, 392
- Crystallography**, 64, 96, 210, 289, 349
- Currents, sea**. Course of, 156
- Cuvier on fossil bones**, 309
- Davy's Bakerian lecture**: action of potassium upon ammonia, 6, 339; analytical exper. on sulphur, 12, 405; on phosphorus, 108, 405; on plumbago, charcoal, and diamond, 110; on boracic acid, 113; on fluoric acid, 120; on muriatic acid, 181, 409; experiments, 187; analysis of ammonia, 339; on metallic bodies, hydrogen, and ammonia, 393; on carbonaceous matter, 408; on nitrogen, alumine, glucine, magnesia and lime, 469
- Davy (J.) Exper. on sulphur and charcoal**, 407
- Deal pendulums**. Walker on, 3
- Diamond**. Davy on, 110
- Diarrhæa**, remedy for, 130

- Dickinson's floating iron dock*, 387;
 method of towing ships, 389, 426;
 system of ship building, 428; iron
 masts, 427
Dividing instruments. Troughton on,
 81, 163
Diving machine. New, 78
Dock, floating, made of iron, 378
Dropsy. On, 312
Earthen-ware. On ancient, 413
Eel. Natural history of the common,
 273
Elective attractions. Young on, 53
Electrical action in thunder-storms,
 161, 201
Ether analysed, 152; on formation
 of, 431
Ewell on med. uses of acetate of lead,
 129
Farey on valleys, 49
*Fever*s, *intermitting*, remedies for, 312
Fish, on breeding, 268, 324; on eels,
 273; salmon-leaps, 321
Floating dock made of iron, 378
Fluoric acid. Davy on, 120
Flying. Machine for, 78
Fossil bones, 309
French National Institute, 70, 143, 227,
 302
Fumigations, medical, 132, 395
Gall's theory of the structure of the
brain, 503
Galvanic apparatus. The best, 26
Gas, a new one, 394, 470
Geology, 19, 49, 137, 190, 311
Gun-powder. Exper. on, 154
Hæmorrhage, internal. New remedy
 for, 129
Hall on telegraph, 124; on broom
 flax, 378; on refraction, 397
Havy's crystallography, 64, 96, 210,
 289, 349, 455
Henry on ammonia, 369, 447
Herschel. Notice by, 237; his re-
 viewer reviewed, 359
History, a prize question, 76
Hooker's expedition to Iceland, 315
Hydraulic ram, a prize question, 76
Hydraulic telescope, a prize question,
 76
Jacobi on breeding fish, 324
Imagination of mothers. On, 347
Indians. Cosmogony of, 261
Inflammation, remedy for, 130
Institution, new, proposed, 453
Instruments, philosophical. New, 77
Kirwan's anemometer, 247
Kittens. Singularly marked, 247
Knight on origin and formation of
roots, 31
Langedorff's expedition, 79
Laplace's Mécanique Céleste, 36, 202,
 252. Supplement to, 233
Learned societies, 70, 143, 227, 302, 468
Lectures, 6, 103, 157, 181, 238, 471
Leech-worm. On the, 376
Lepere's artificial puzzolano, 178
Light. Particulars concerning, 359
Longchamp on formation of nitre, 334
Mammoth. On the, 310
Masts, sliding tubular, made of iron,
 428
Mécanique Céleste. Laplace's, 36,
 202, 252. Supplement 233
Medicine, 129, 132, 281, 312, 395,
 453
Medusæ. On, 308
Merino sheep distributed by the king's
orders, 155
Messenger-pigeons, on training, 317
Metevrology, 80, 157, 161, 240, 320,
 398
Milt of fishes analysed, 151
Mineralogy, 317
Mineralogy. Mitchell's discourse on,
 125
Mitchell's arrangement of minerals,
 125
Moon's node. On determining, 70
Morveau on gun-powder, 154
Mucus, animal. On, 302
Muriate of soda. London's process
 to purify by fusion, 314
Muriatic acid. Davy on, 181, 409
Muriatic ether. On, 153
Muscular motion. Wollaston on, 392
Musical instrument. A new, 315
Nævia materna. Quere, 347
Naval architecture, improved, 387
Nitric ether. On, 153
Nitrogen a compound, 10
Nutmeg. Proper way to grate 396
Ocean. On action of, 19, 137
Oil of cabbage seed. Properties of,
 319
Onions. Chemical products of, 151
Optics. A prize question, 76
Patents, 79, 233, 319, 398, 471
*Pearson's proposal for a new institu-
 tion*, 453
Peck on the leech-worm, 376
Pendulum rods. E. Walker on, 3
Pepys and Allen on respiration, 379,
 415
Phosphoric ether. On, 153
Phosphorus. Davy on, 103, 405

- Phosphorus*, a compound, 110
Physiology, 148
Pigeons, messenger. On training, 317
Pigments found in Pompeia, 411
Plumbago. Davy on, 110
Pompeia, pigments found in, 411
Potassium. Davy on, 6, 108, 181, 339, 393
Pottery. On ancient, 413
Printing from stone, 77
Prize questions, 76, 228
Puzzotano. On, 178; substitutes for, 179
Rain-table, 158
Refraction. Instance of, 397
Religion. A prize question, 76
Reptiles, amphibious, 147
Respiration. Allen and Pepys on, 379, 415
Roots. Origin and formation of, 31
Rotative steam-engine, Clegg's, 401
Royal society, 391, 392, 468
Royal academy, Berlin, 76
Rumford on fluids superposed without mixing, 155
Salivation excessive, to counteract, 131
Salmon to breed, 268, 324; ascent of, over water-falls, 321
Saltpetre. Phenomena in formation of, 334
Saussure's analysis of alcohol and ether, 152
Ships, to dock in deep water, 387; method of towing, 389; new method of building, 428
Silicæ volatilised, 397
Society of antiquaries, 394
Societies, learned, 70, 143, 227, 468
Sodium. Davy on, 393
Sounds in vapours. On, 277
Spirit of turpentine a cure for tape-worm, 396
Spurzheim's theory of the structure of the brain, 303
Steam-engine, Clegg's, 401
Sugar. The cane, cultivated in France, 313
Sulphates. Action of fire upon, 154
Sulphur. Davy on, 12; a compound, 13, 19, 405
Sulphuretted hydrogen, contains oxygen, 17
Sulphurets. Action of fire upon, 154
Sulphuric acid. Manufacture of, 154
Sulphuric ether. On, 153
Tape-worm. Remedy for, 396
Telegraph. New route proposed, 124
Telescope, hydraulic, 76; goniometrical, 77; hist. of, 241
Telluriated hydrogen, a new gas, 394
Thenard on ethers, 431; on combinations of acids with animal and vegetable substances, 439
Thermometers. Morveau on, 236
Thunder-storms. Varley on, 161, 201
Timbers, to bend, 428
Time-pieces. Walker on, 3
Topaz, the Scots, 470
Torpidity of animals, 144
Trees, young, to transport safely, 155
Trevithick's floating iron dock, 387; method of towing ships, 389, 426; system of ship building, 428; iron masts, 427
Troughton on dividing instruments, 81, 163
Trouts, to breed, 268, 324
Ulcers, a cure for, 281
Uree. On, 302
Varley on thunder-storms, 161, 201
Vegetable substances combined with acids, 439
Vermis of all kinds destroyed by fumigation, 396
Voltaic apparatus. On the best, 26
Walker, (E.) on pendulums, 3
Wernerian natural history society, 470
Wollaston's Croonian lecture, 392
Wood. Acetic acid obtained from, 235
Young's table of elective attractions, 53
Zinc. On laminated, 285
Zoology, 144, 148, 227, 308



Fig. 1.



Fig. 2.



Fig. 3.

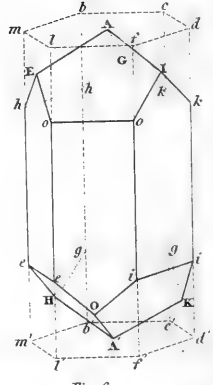

Fig. 4.

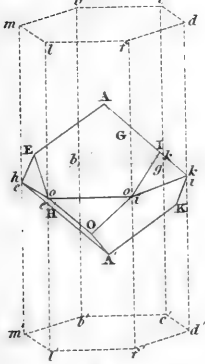

Fig. 5.

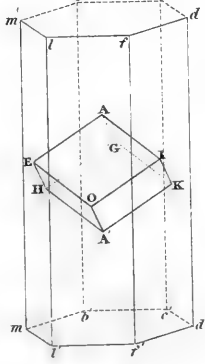

Fig. 6.

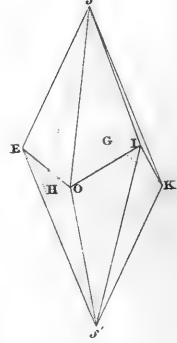

Fig. 7.

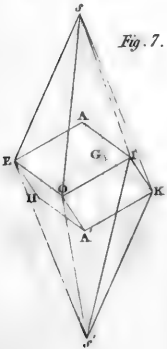

Fig. 8.

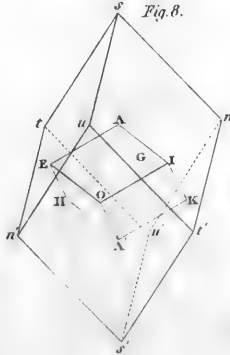
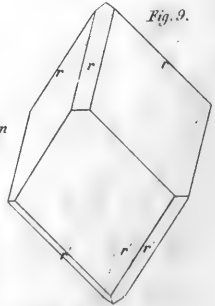

Fig. 9.





Haüy Pl. 2.

Fig. 10.

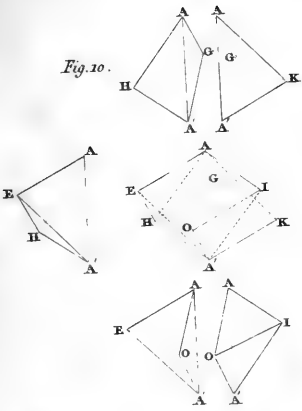

Fig. 11.

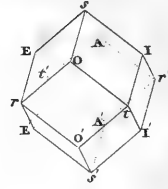

Fig. 13.

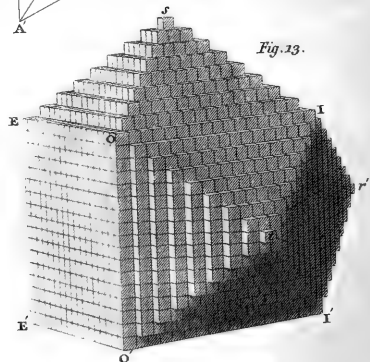

Fig. 12.

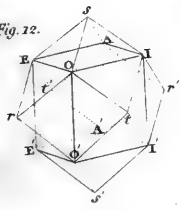

Fig. 15.

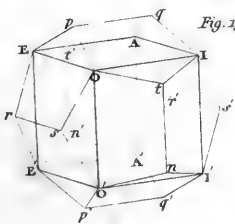

Fig. 14.

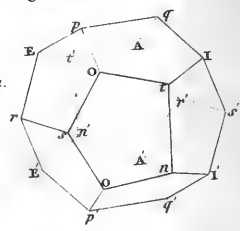
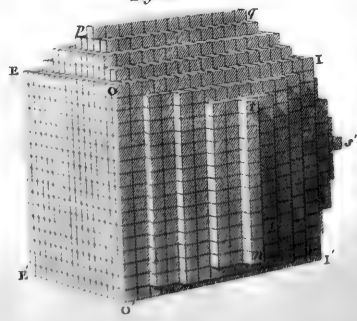
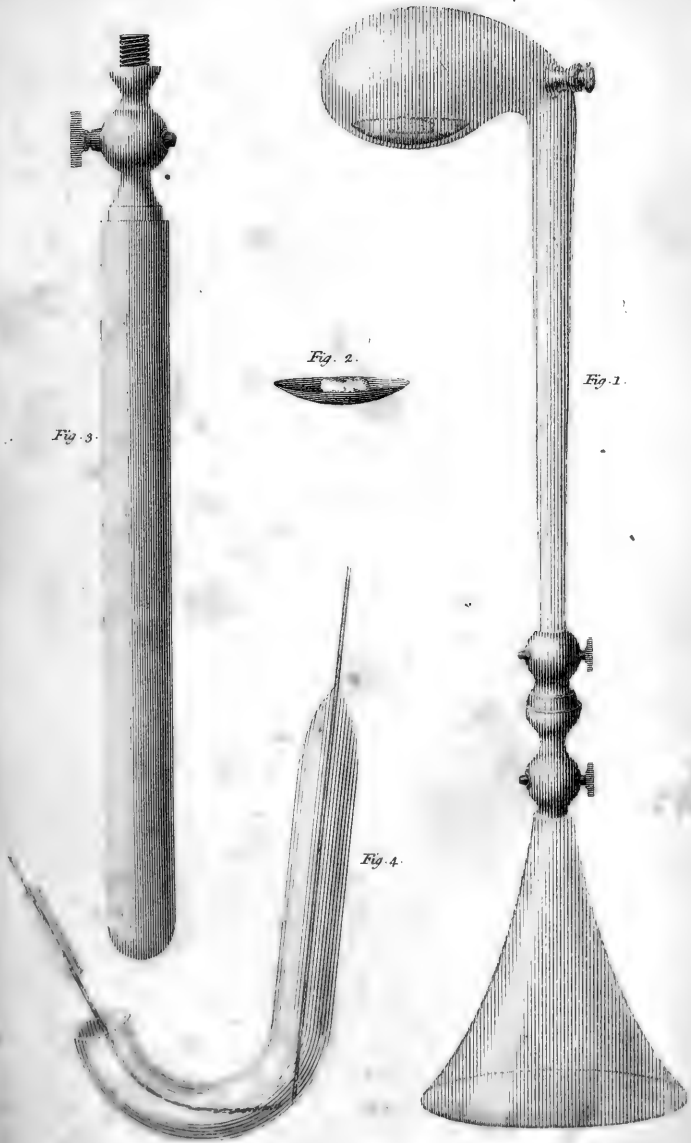

Fig. 16.



Lowry sculp.





M. Davy's Apparatus for heating Potassium in gases &c.



W. R. Broughton's New Dividing Apparatus

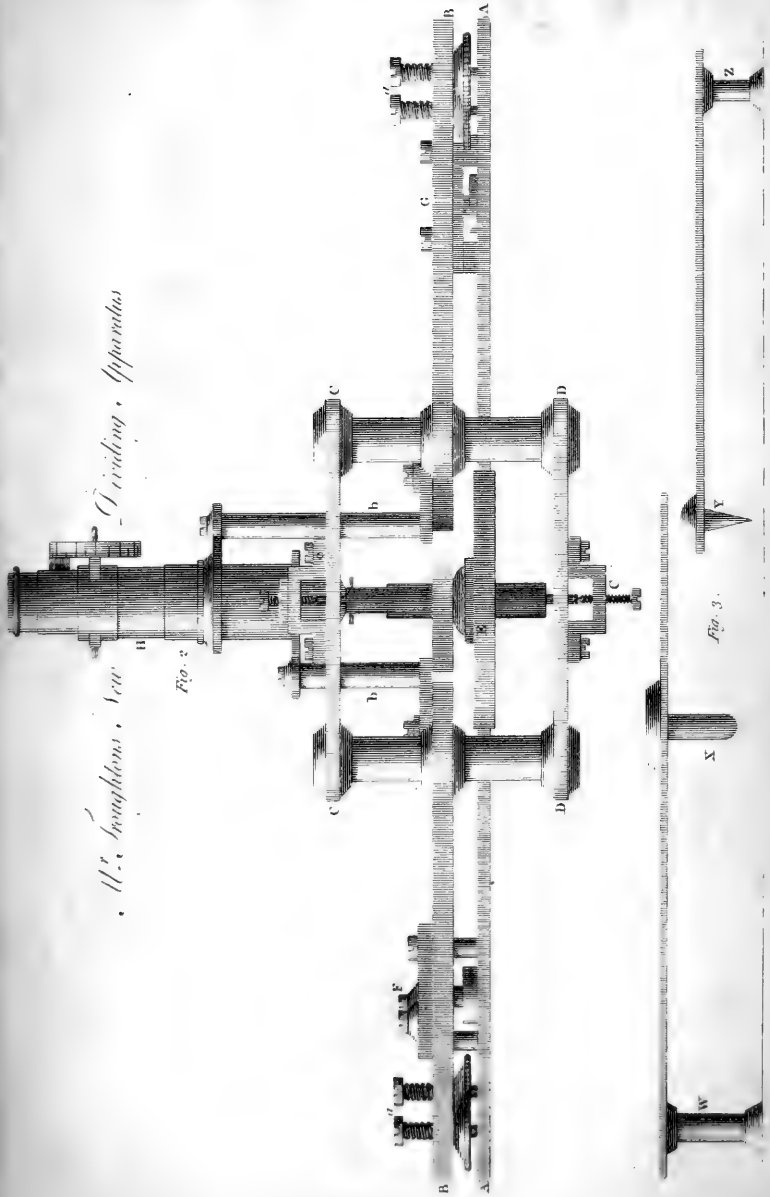

of force on



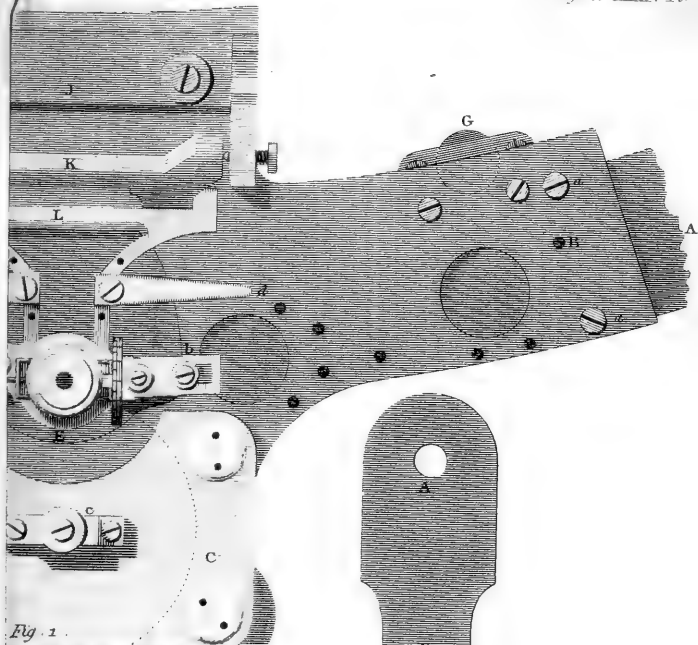
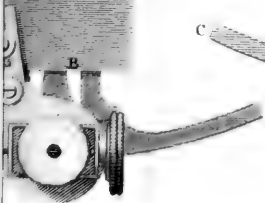
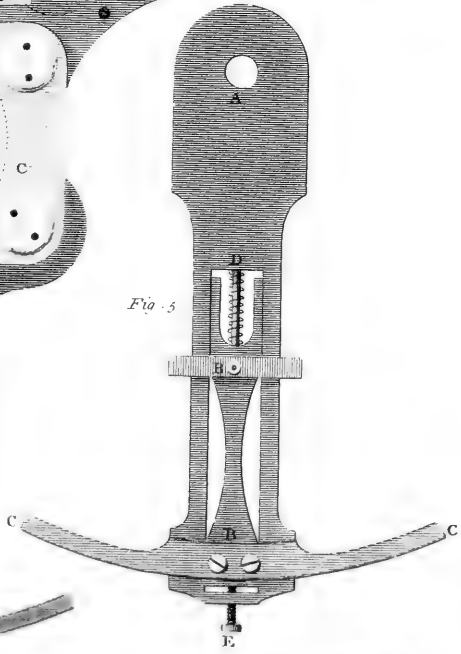
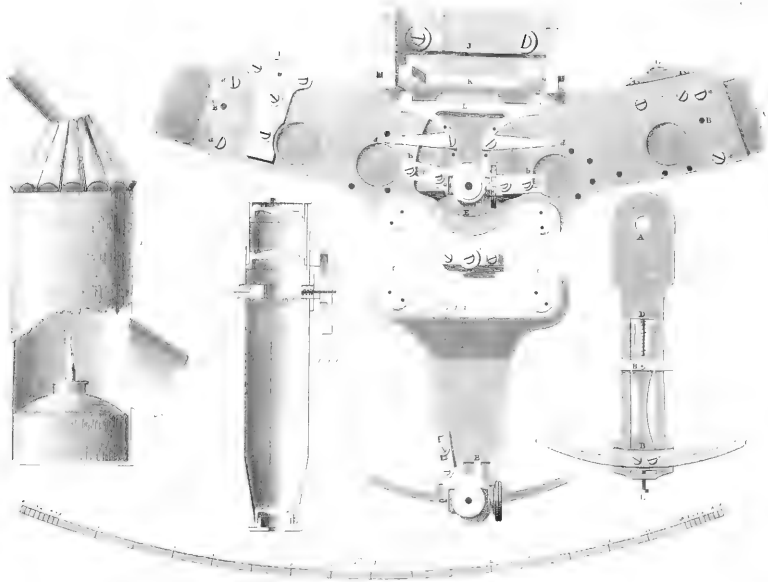

Fig. 5





W. Thompson's Self-Propelling Apparatus

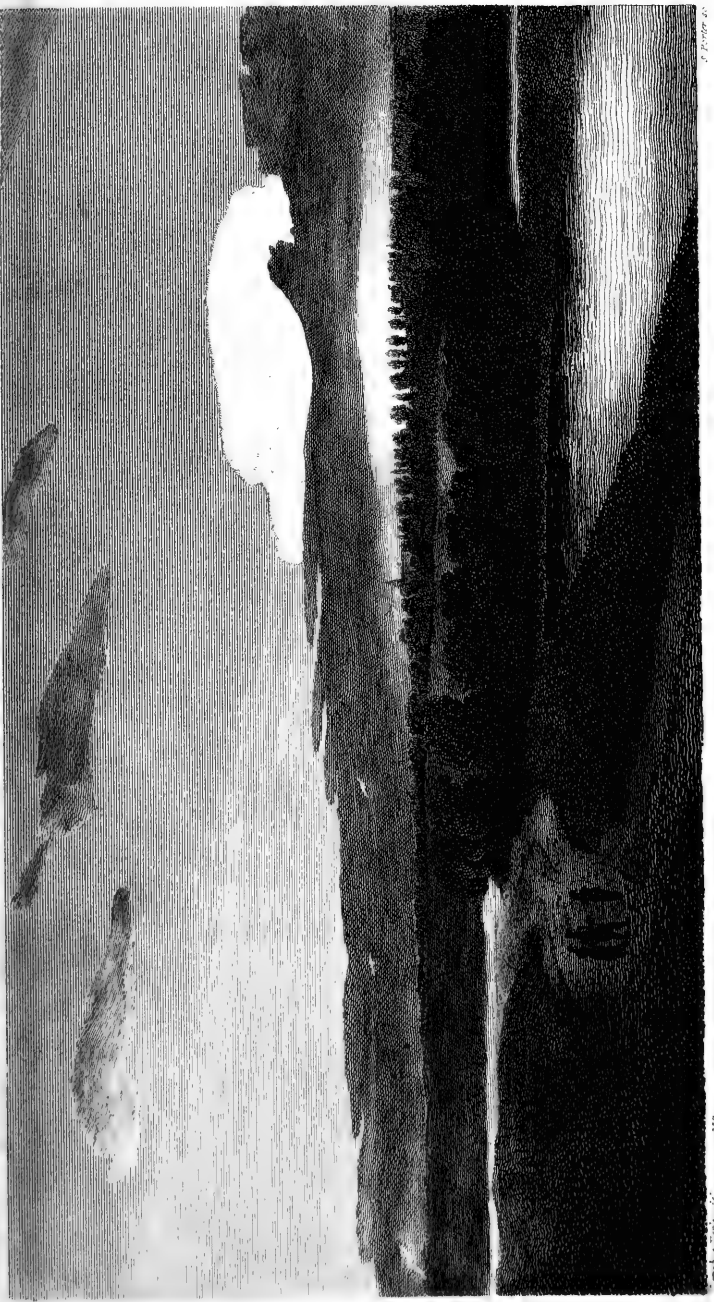
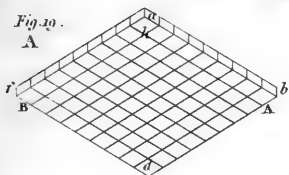
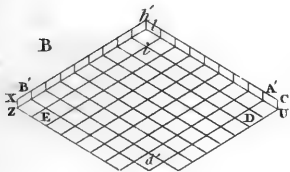



Fig. 10.



B



C

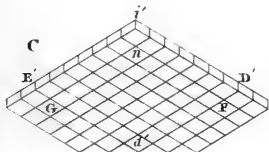

D

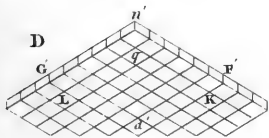

E

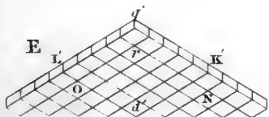

F



G

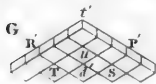

H



I

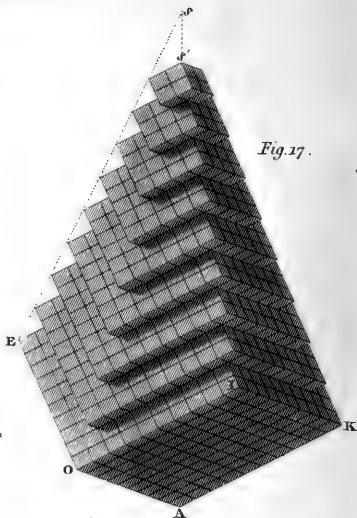

Fig. 17.

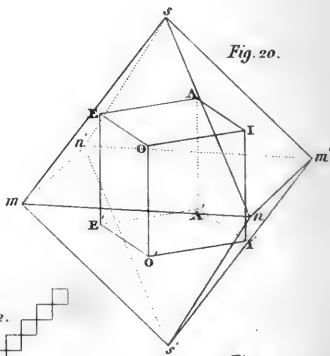

Fig. 20.

Fig. 22.



Fig. 18.

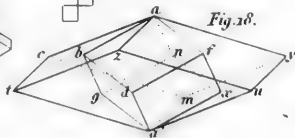

Fig. 21.

a	b	c	d	e	f	g	h	i
n	o	p	q	r	s	t	u	v
q	r	s	t	u	v	w	x	y
r	s	t	u	v	w	x	y	z
s	t	u	v	w	x	y	z	a
t	u	v	w	x	y	z	a	b
u	v	w	x	y	z	a	b	c
v	w	x	y	z	a	b	c	d
w	x	y	z	a	b	c	d	e
x	y	z	a	b	c	d	e	f
y	z	a	b	c	d	e	f	g
z	a	b	c	d	e	f	g	h
a	b	c	d	e	f	g	h	i



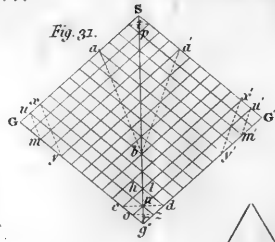
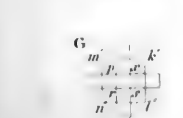
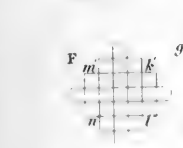
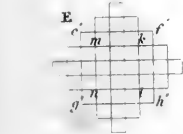
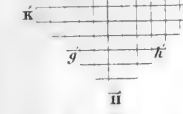
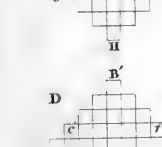
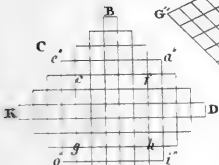
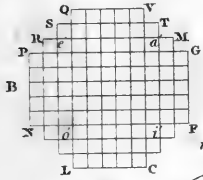
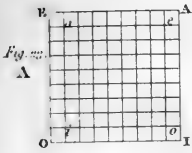

Fig. 30.

Fig. 25.

Fig. 26.

Fig. 28.

Fig. 29.

Fig. 27.



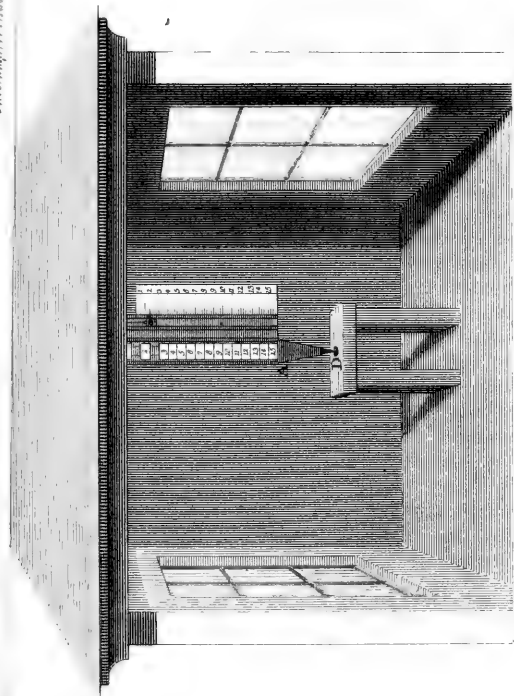
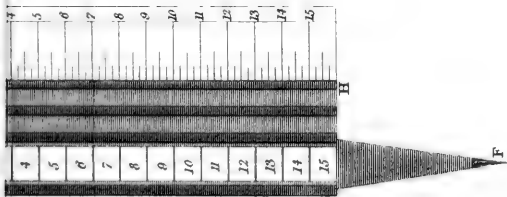

Hirwan's Anemometer.

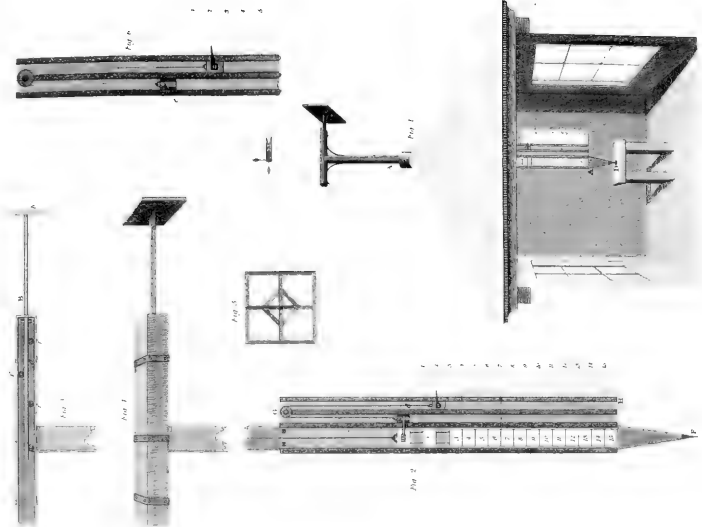

Reinhold's Anemometer

Mrs. Allen & Peppes Experiments on Respiration.

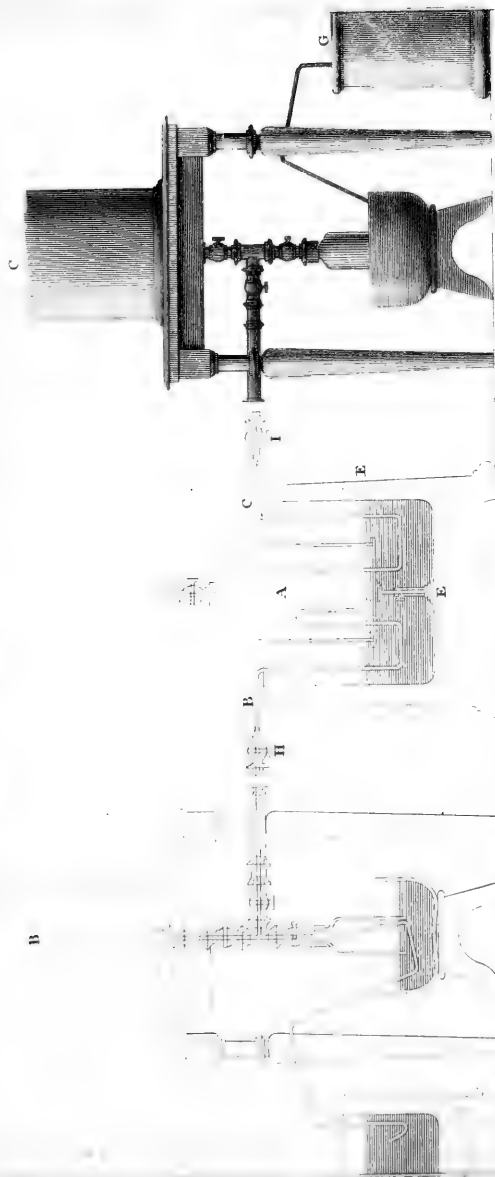

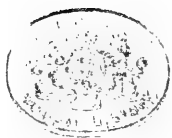

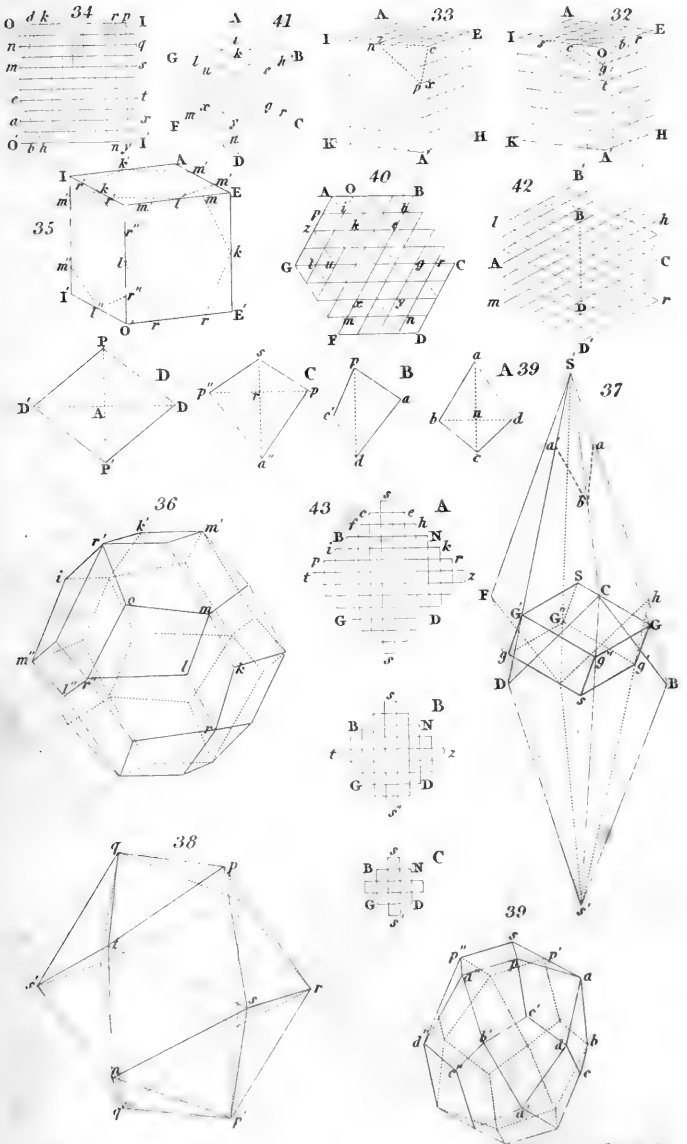



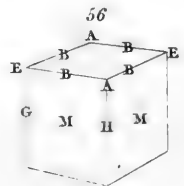
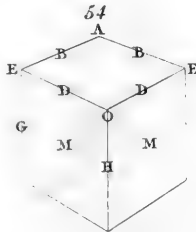
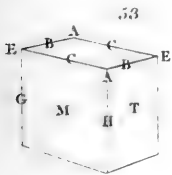
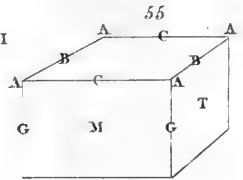
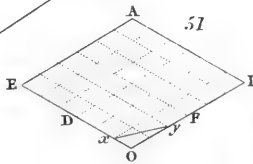
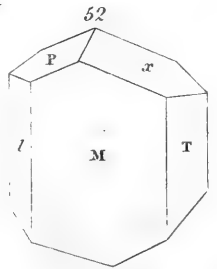
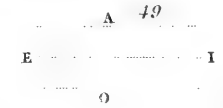
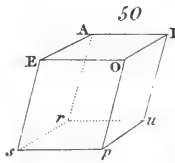
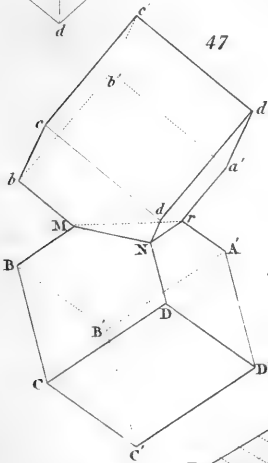
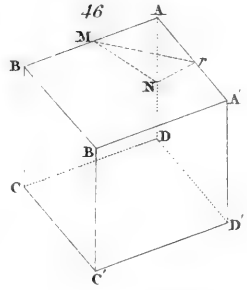
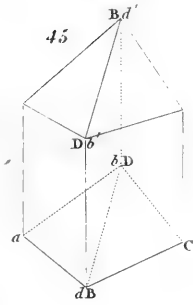
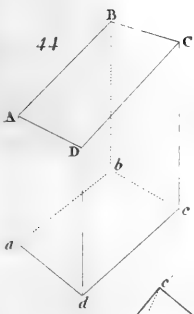

Lowry Sculp.



Fig. 5.

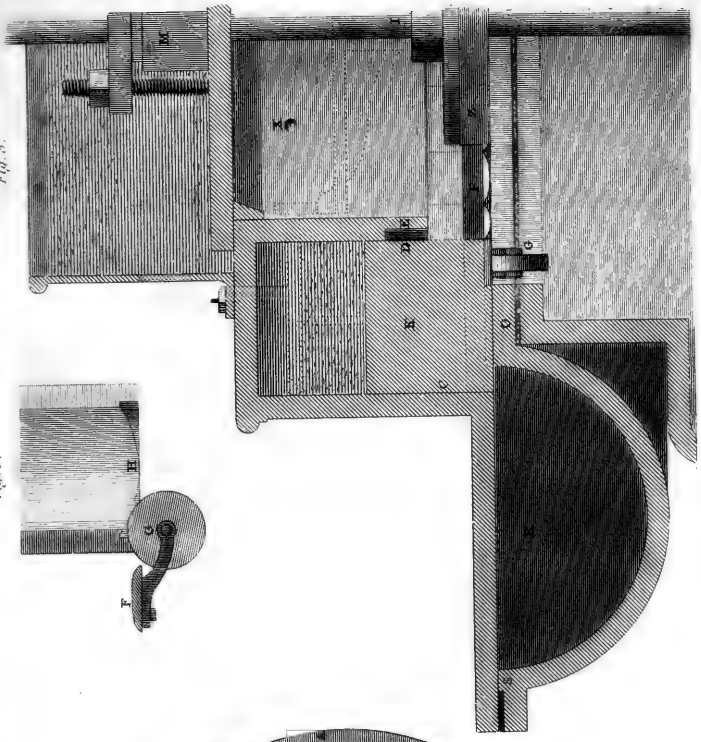

Fig. 3.

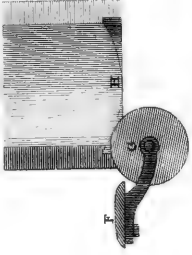
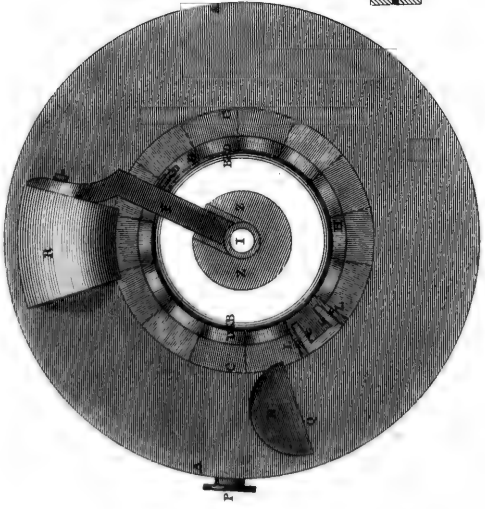

Fig. 1.



M. Negg's Rotative Steam Engine.

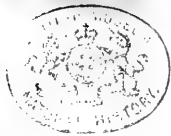
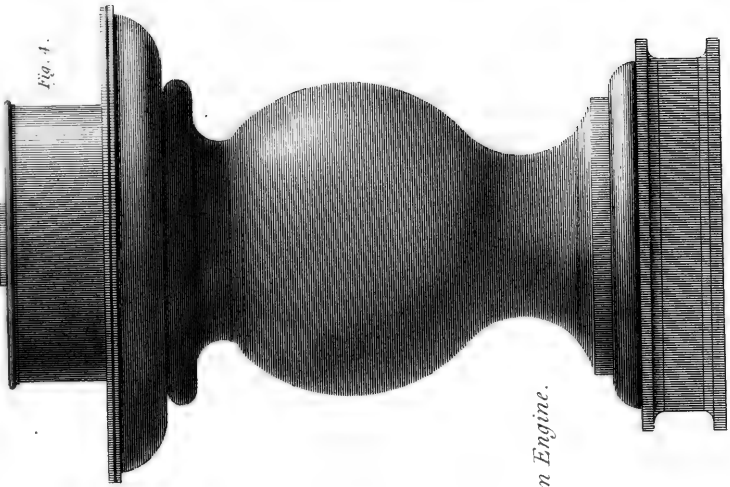
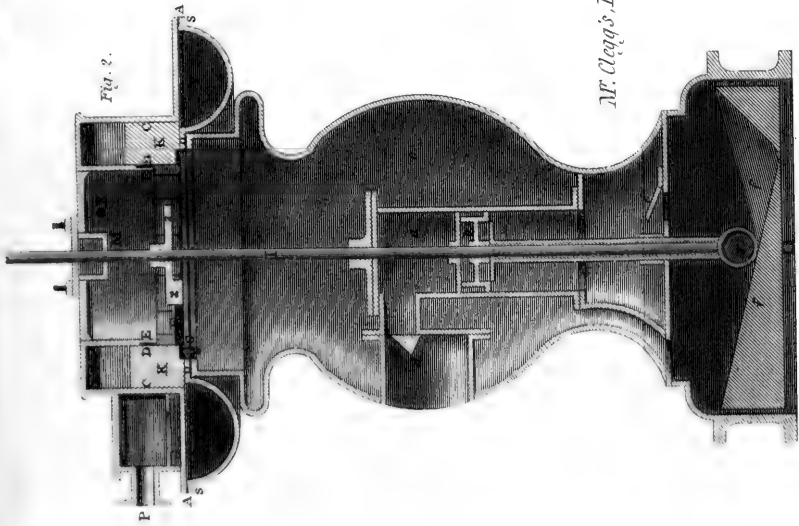

Fig. 1.



W. Clegg's Rotative Steam Engine.

Fig. 2.





CONTENTS of NUMBER CXXXV.

	Page
I. On Deal Pendulum Rods. By Mr. E. WALKER	3
II. The Bakerian Lecture. An Account of some new analytical Researches on the Nature of certain Bodies, particularly the Alkalies, Phosphorus, Sulphur, Carbonaceous Matter, and the Acids hitherto undecomposed; with some general Observations on Chemical Theory. By HUMPHRY DAVY, Esq., Sec. R.S., F.R.S. Edin., and M.R.I.A.	6
III. An Inquiry into the Terrestrial Phenomena produced by the Action of the Ocean. By JOHN CARR, Esq., of Manchester.—No. I.	19
IV. An Account of some Experiments, performed with a View to ascertain the most advantageous Method of constructing a Voltaic Apparatus, for the Purposes of Chemical Research. By JOHN GEORGE CHILDREN, Esq., F.R.S.	26
V. On the Origin and Formation of Roots. In a Letter from T. A. KNIGHT, Esq., F.R.S., to the Right Hon. Sir JOSEPH BANKS, K.B., P.R.S.	31
VI. Analysis of the Mécanique Céleste of M. LA PLACE, Member of the French Institute, &c. By M. BIOT	36
VII. Account of the Dissection of a Human Fœtus, in which the Circulation of the Blood was carried on without a Heart. By Mr. B. C. BRODIE. Communicated by EVERARD HOME, Esq., F.R.S.	43
VIII. Geological Observations on the Excavations of Valleys, the supposed Existence of numerous Lakes at former Periods where Valleys now exist, which the Streams flowing through them are said to have broken down, &c.: in Reply to Mr. JOHN CARR's Letter in the last Number, p. 452. By Mr. JOHN FAREY	49
IX. A numerical Table of elective Attractions; with Remarks on the Sequences of double Decompositions. By THOMAS YOUNG, M.D. For. Sec. R.S.	53
X. On Crystallography. By M. HAUY. Translated from the last Paris Edition of his <i>Traité de Minéralogie</i>	64
XI. Proceedings of Learned Societies	70
XII. Intelligence and Miscellaneous Articles—Meteorological Table	77—80

* * * Communications for this Work, addressed to the Editor, at No. 1, Carey-street, Lincoln's Inn, will meet with every attention.

Vol. XXXII. Mr. CLEALL's Machine for thrashing Hemp; and Mr. BOND's Machine for breaking Hemp.—Mr. WARD's Compensation Pendulum.—Mr. GROOMBRIDGE's Diagram of the Motion of the Planet Vesta.—A Portrait of Sir H. C. ENGLEFIELD.—Mr. CHARLES LE CAAN's Tram-Plates—and Mr. COLLIER's Ship Stove.—Apparatus employed by MESSIS. ALLEN and PEPYS in their Experiments on Respiration.—Mr. HENRY's Apparatus for Decomposing Compound Inflammable Gases.—Apparatus employed in the Royal Institution for the Decomposition of Potash by Iron.—BELL's Method of saving Shipwrecked Mariners.

Vol. XXXIII. Mr. JAMES ELMES's Portable Bridge.—Mr. KNIGHT's new Method of training Fruit Trees.—Mr. HERSCHEL's Figures of the Comet of 1807.—Two Plates to illustrate Dr. WILLIAM RICHARDSON's Paper on the Basaltic Surface of the Counties of Derry and Antrim: viz, A View of PORTMOON.—A View of PLESKIN, on the N. W. side of Bengore Promontory.—Mr. CLEGG's Apparatus for making Carbonated Hydrogen Gas from Pit-Coal.—Mr. RICHARDSON's Machine for raising large Stones out of the Earth;—and Mr. GOUGH's new Hygrometer.—PILTON's Light Fence for Inclosures, which becomes invisible at a short Distance.—Proposed Improvements in Telescopes, by M. BURCKHARDT and by Dr. BREWSTER; and M. BOULLAY's Apparatus for Phosphoric Ether.—Major LE HARDY's Telegraph.—Capt. BOLTON's improved Jury Mast; and Capt. BALL's Method of Fishing Anchors.—Plan and Section of the Thames Archway.—Plan of Stonyhurst Scientific Establishment.—Mr. TAD's Method of causing a Door to open over a Carpet;—and Mr. BARLOW's Wrench for Screw Nuts of any Size.

ELIAS HALL, opposite the Inn, at Castleton, Derbyshire, Manufacturer of *Ornaments* of every Description, in Fluors and other Spars, (usually called Petrifications,) in Gypsum, Marble, &c., takes this opportunity of informing his Friends and the Public, particularly such as are travelling the High Peak of Derbyshire, with a view to the Geological and Scientific Information which that interesting and astonishing District is calculated to afford, that he has a large Collection of Specimens of Native Fossils of the Mineral Minerals and Toadstone Strata constantly on Sale; as well of the Rocks, Spars, and Metallic Ores, as of the interesting organic Remains of the Animal Kingdom peculiar to these Strata: which Specimens being collected by himself, he will be able to point out to Collectors, the local and relative Situation of each in the Stratification of the District. By a reference to a Model of the County of Derby, which ELIAS HALL has executed, by Permission, agreeably to the Mineralogical Map which Mr. JOHN FAREY of London is executing of the whole County of Derby, he hopes to be able to explain fully to Scientific Gentlemen or Ladies, who may do him the Honour to inspect his Factory and Collections, or take him out with them in addition to the ordinary Guides, in their Excursions in the Neighbourhood, the Nature and Relations of every Particular worthy of Observation, respecting the Rocks, Caverns, Mines, Stratification, Dislocation of the Strata and extraneous Fossils of the District, according to the most recent Discoveries on the Subject; which, from their Importance and Novelty, cannot fail of giving much Satisfaction to the Curious.

N.B. Orders for Ornaments punctually executed, Wholesale or Retail, and Ornaments repaired, cleaned, &c.

CONTENTS OF NUMBER 139.

	Page
XLIV. On the Ascent of Salmon over the Elevations in the Course of Rivers, called Salmon-Leaps. By JOHN CARR, Esq., of Manchester	321
XLV. On the Breeding of Fish and the Natural History of their Generation.	324
XLVI. On some Phænomena which take place in the Formation of Saltpetre. By M. LONGCHAMP	334
XLVII. New analytical Researches on the Nature of certain Bodies, being an Appendix to the Bakerian Lecture for 1808. By HUMPHRY DAVY, Fsq., Sec. R.S. Prof. Chem. R.I.	339
XLVIII. Inquiry whether Nævia Materna, with which Children are sometimes born, should be attributed to the Imagination of the Mother	347
XLIX. On Crystallography. By M. HAUY. Translated from the last Paris Edition of his <i>Traité de Minéralogie</i>	349
L. An Examination of the Review which appeared in the XIIIth Number of " <i>The Retrospect</i> ," &c., of Doctor HERSHEL's Essay on the coloured Rings discovered by Sir ISAAC NEWTON	359
LI. Experiments on Ammonia, and an Account of a new Method of analysing it, by Combustion with Oxygen and other Gases; in a Letter to HUMPHRY DAVY, Esq., Sec. R.S. &c., from WILLIAM HENRY, M.D., F.R.S., V.P. of the Lit. and Phil. Society, and Physician to the Infirmary, at Manchester	369
LII. Observations on the Leech-worm	376
LIII. On Broom Flax	378
LIV. On Respiration. By WILLIAM ALLEN, Esq., F.R.S. and WILLIAM HASLEDINE PEPYS, Esq., F.R.S.	379
LV. Description of certain Inventions for the Improvement of Naval Architecture, for increasing the Comforts of Mariners, and for facilitating Naval Enterprises. By Messrs. R. TREVITHICK and R. DICKINSON	387
LVI. Notices respecting new Books	391
LVII. Proceedings of Learned Societies	392
LVIII. Intelligence and Miscellaneous Articles—Meteorological Table	394—400

* * * Communications for this Work, addressed to the Editor, at No. 1, Carey-street, Lincoln's Inn, will meet with every attention.

Plate of the Apparatus employed by Mess. ALLEN and PEPYS in their Experiments on Carbonic Acid—A fourth Plate to illustrate M. CUVIER's Paper on Elephants—Lieut. Col. CRICHTON's Bed for the easy Conveyance of Sick and Wounded Soldiers: engraved by PORTER.—And Capt. PALLEY's Improved Telegraph: engraved by PORTER.

Vol. XXX. Sir H. C. ENGLEFIELD's Mountain Barometer, engraved by LOWRY—A Plate to illustrate M. CUVIER's Paper on Elephants—Another Plate on the same Subject.—1 and 2. Two Plates to illustrate M. CUVIER's Paper on Elephants, engraved by PORTER.—3. Figures to illustrate M. HERSCHEL's Paper on Coloured Rings.—A Skeleton of the American Mammoth, engraved by PORTER.—A Portrait of M. CARNOT—The Oil mill of Bangalore.

Vol. XXXI. Mr. DAVY's new Eudiometer.—Geological Sections of Strata, in Matlock, Derbyshire, by Mr. WHITEHURST and Mr. FAREY.—Illustration of the Chinese Method of propagating Fruit Trees by Abscission—And Mr. BROAD's Gauge for measuring Timber.—Illustration of Mrs. D'OYLEY's Method of breeding Poultry; Mr. DREW's Balance Level for laying-out Land for Irrigation; and an Experiment in Optics.—Mr. E. TURKELL's Construction of Chemical Muffles.—Mr. GILPIN's Machine for raising Coals and Ores.—WILSON's Secure Boat, or Life Boat; and BOSWELL's improved Capstan: engraved by PORTER.—PEPYS's Apparatus for Decomposing the Alkalis under Naphtha: engraved by LOWRY.—ATKINS's improved Hydrometer for weighing Solids and Fluids.

Vol. XXXII. Mr. CLEALL's Machine for thrashing Hemp; and Mr. BOND's Machine for breaking Hemp.—Mr. WARD's Compensation Pendulum.—Mr. GROOMBRIDGE's Diagram of the Motion of the Planet Vesta.—A Portrait of Sir H. C. ENGLEFIELD.—Mr. CHARLES LE CAEN's Tram-Plates—and Mr. COLLIER's Ship Stove.—Apparatus employed by Messrs. ALLEN and PEPYS in their Experiments on Respiration.—Mr. HENRY's Apparatus for Decomposing Compound Inflammable Gases.—Apparatus employed in the Royal Institution for the Decomposition of Potash by Iron.—BELL's Method of saving Shipwrecked Mariners.

Vol. XXXIII. Mr. JAMES ELMES's Portable Bridge.—Mr. KNIGHT's new Method of training Fruit Trees.—Mr. HERSCHEL's Figures of the Comet of 1807.—Two Plates to illustrate Dr. WILLIAM RICHARDSON's Paper on the Basaltic Surface of the Counties of Derry and Antrim: viz. A View of PORTMOON.—A View of PLESKIN, on the N. W. side of Bengore Promontory.—Mr. CLEGG's Apparatus for making Carbonated Hydrogen Gas from Pit-Coal.—Mr. RICHARDSON's Machine for raising large Stones out of the Earth;—and Mr. GOUGH's new Hygrometer.—PILTON's Light Fence for Inclosures, which becomes invisible at a short Distance.—Proposed Improvements in Telescopes, by M. BURCKHARDT and by Dr. BREWSTER; and M. BOULLAY's Apparatus for Phosphoric Ether.—Major LE HARDY's Telegraph.—Capt. BOLTON's improved Jury Mast; and Capt. BALL's Method of Fishing Anchors.—Plan and Section of the Thames Archway.—Plan of Stonyhurst Scientific Establishment.—Mr. TAD's Method of causing a Door to open over a Carpet;—and Mr. BARLOW's Wrench for Screw Nuts of any Size.

Vol. XXXIV. Two Plates to illustrate M. HAUY's Crystallography.—Apparatus to illustrate Mr. DAVY's Bakerian Lecture.—A Quarto and an Octavo Plate descriptive of Mr. TROUGHTON's new dividing Instrument.—A Plate to illustrate Mr. VARLEY's Paper on Thunder Storms.—Another Plate to illustrate M. HAUY's Theory of Crystallization.—A Quarto Plate to illustrate Mr. KIRWAN's new Anemometer; engraved by PORTER.—An Octavo Plate to illustrate M. HAUY's Crystallography; engraved by LOWRY.

