

FIGHTING
BY
ACETYLENE

GIBBS

DEVAN NOSTRAND COMPANY

3503

99/2³⁰

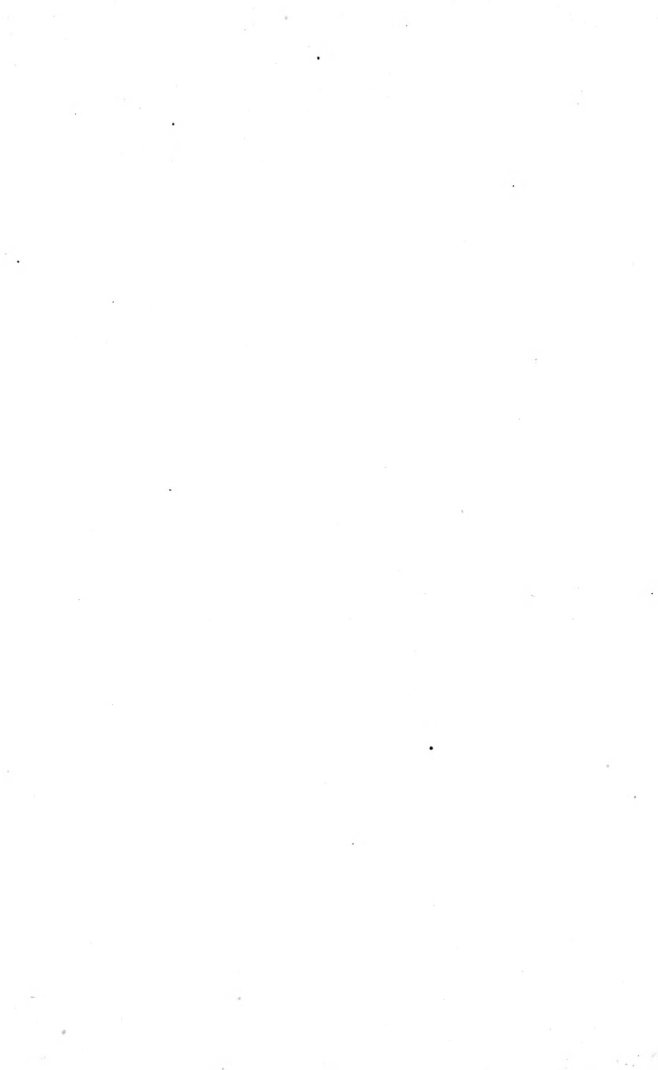



LIGHTING
BY
ACETYLENE

GENERATORS, BURNERS AND
ELECTRIC FURNACES

BY
WILLIAM E. GIBBS, M.E.



NEW YORK
D. VAN NOSTRAND COMPANY

LONDON
CROSBY LOCKWOOD AND SON

1893

JF

COPYRIGHT, 1898, BY
D. VAN NOSTRAND COMPANY

TROW DIRECTORY
PRINTING AND BOOKBINDING COMPANY
NEW YORK

TABLE OF CONTENTS

	PAGE
INTRODUCTION,	I
ACETYLENE (HISTORY),	4
DANGERS OF ACETYLENE,	7
EXPLOSIVENESS,	8
ACETYLIDE OF COPPER,	10
TOXIC PROPERTIES,	10
EFFECTS ON THE EYES,	12
ELECTRIC FURNACES,	14
INTERMITTENT FURNACES,	15
CONTINUOUS FURNACES,	25
GENERATION OF ACETYLENE,	34
IMPURITIES OF CARBIDE AND PURIFICATION OF ACETYLENE,	37
GENERATORS,	43
FIRST CLASS,	44
SECOND CLASS,	69
THIRD CLASS,	73
ACETYLENE LAMPS,	85
ACETYLENE BURNERS,	93
AUTHOR'S EXPERIMENTS,	103
CONCLUSION,	121
ADDENDA,	125
FIRE REGULATIONS,	131
LIST OF UNITED STATES PATENTS,	135

LIGHTING BY ACETYLENE.

INTRODUCTION.

IN an attempt to set forth the facts concerning the development of the kindred industries of calcic carbide production and the generation of acetylene therefrom, it must be borne in mind that both processes, so far as their industrial application is involved, are of very recent date.

Whatever is written about either must be considered as an exposition of the art so far only as it is known at the moment of writing. Revision or even radical change of ideas may be expected from time to time as continued experiment brings to light new facts about these hardly known substances.

A recent serious explosion of liquefied acetylene prompts the writing of what follows, since it would seem that ignorance or neglect of the admonitions of earlier experimenters was to blame for an accident which cannot but prejudice many against the use of a valuable and safe illuminant.

Since the French have been unusually keen in the pursuit of information concerning calcium car-

bide and acetylene, and have not only devised many machines for generating the gas, and furnaces for producing the carbide, but have made public the results obtained, their books and pamphlets on the subject have been freely drawn upon for details of foreign practice.

As for the American gas generators, a description of types of those which the author has been able to discover from an examination of the United States Patent Office records, direct interviews with the manufacturers or inquiry among the carbide dealers is included; but, since hundreds are experimenting in this field, and since two or three new generators are patented in this country each week, it is quite impossible to include the most recent ones.

Suffice it to say that, in the very nature of the problem involved, generators may all be divided into three classes, and that any new machine can differ from the existing forms only in matters of detail.

For the production of acetylene it is necessary to bring calcic carbide into contact with water in some kind of vessel from which the resulting gas may be conveyed for use.

Whether the carbide is thrown into water, or the water is poured upon the carbide, is in general terms a matter of indifference, the result being practically the same.

When, however, the renewal of the carbide becomes necessary in order to keep up a continuous supply of gas, complications immediately enter the

problem, which becomes still further involved when the removal of the lime resulting from the reaction is attempted.

The generation of a quantity of acetylene is a very simple matter. The devising of means for delivering a constant supply of gas, supplying calcic carbide to the generator and removing the lime therefrom has taxed the ingenuity of some of our ablest inventors.

The ideal machine has certainly not yet been invented, but existing forms are being constantly improved, and at the present writing, the safe, efficient and cheap lighting of houses by acetylene is an accomplished fact.

HISTORY.

ALTHOUGH only recently become of commercial importance, acetylene has been known chemically since 1836, when the chemist Edmond Davy announced the discovery of "a new gaseous bicarburet of hydrogen and of a particular compound of carbon and potassium, or carburet of potassium," in the British Association Reports, 1836, pt. 2, p. 62.

In 1861, the German chemist Wöhler prepared calcium carbide by heating a mixture of lime and carbon in the presence of zinc.

Berthelot, in his classic synthesis of a hydrocarbon, passed hydrogen through a receiver in which an electric arc was maintained between carbon electrodes. The hydrogen combined with the vaporized carbon to form acetylene (C_2H_2), which was passed through an ammoniacal solution of copper, where acetylide of copper ($C_2H_2Cu_2O$) was precipitated.

Berthelot, in 1866, obtained carbide of sodium by gently heating metallic sodium in an atmosphere of acetylene. The acetylene, being absorbed, produced C_2H_2Na , and, upon being raised to a red heat, the hydrogen was driven off, leaving sodium carbide (C_2Na) as a heavy, dark, stone-like mass, which gave off acetylene when thrown into water.

Others since then have formed various carbides,

which have been used in the laboratory as a convenient means of producing acetylene.

In a note to the Académie des Sciences, presented on December 12, 1892, Moissan, who had been experimenting with the electric furnace, made the statement that "If the temperature of the electric furnace reaches $3,000^{\circ}$ the material of the furnace itself, the quick-lime, melts and runs like water. At this temperature the carbon rapidly reduces the oxide of calcium and the metal is set free in abundance. It combines easily with the carbon of the electrodes to form carbide of calcium, fluid at this heat, which is easily recovered."

In March, 1894, Moissan presented to the Académie a sample of pure crystalline calcium carbide which he had obtained by submitting a mixture of powdered lime and carbon to the action of the electric furnace.

Mr. Thos. L. Willson, who had also been experimenting in this country with the electric furnace, announced about the same time the discovery of a process for preparing pure crystalline calcium carbide therein, and, in the discussion concerning priority of invention, which followed, claimed to have accidentally discovered the substance and its properties in 1888.

It is at present impossible to decide to whom belongs the credit of the discovery of calcium carbide in its commercial form and for the industrial purpose of gas-making.

When we consider the possibilities opened up by

the electric furnace, and the number of new facts which are certain to be brought to light by its use, it should not be surprising that more than one experimenter should discover the same phenomena or hit upon the same method of operation.

DANGERS OF ACETYLENE.

Two or three years ago, when the commercial production of acetylene was first attracting general attention, the most diverse and exaggerated accounts of its dangerous properties were published. By some it was declared to be intensely poisonous, by others frightfully explosive, while a third faction announced that it readily formed explosive compounds with the metals of the pipes and gasometers necessary for its use.

Since the truth concerning this gas is now well known, it seems needless to enter upon a detailed description of the dangers then predicted, and it will be sufficient excuse for the misinformation so generally disseminated to say that much of the early carbide was very impure.

No doubt the gas resulting from its decomposition contained all kinds of undesirable substances, some explosive, some toxic, and some tending to favor the formation of the detonating acetylides of metals.

Now, however, that we may be sure of the purity of our carbide, the dangers attending the use of acetylene have been exactly determined.

Without going into the details of the experiments conducted by the ablest chemists of the time, or re-

lating the experiences of those who have labored to bring into vogue the practical and industrial application of acetylene, it will suffice to present a synopsis of the dangers attending the use of this gas and the means for obviating them :

EXPLOSIVENESS.

Acetylene, as alarmists are so fond of stating, is an endothermic substance, which means that in its production a certain quantity of heat is absorbed and disappears. This heat, or its equivalent in some other form of energy, exists in the substance, tending and striving to reassert itself upon provocation. For this reason the gas, under certain conditions, is an unstable body. It tends to resolve itself into its component elements, carbon and hydrogen, and when such dissociation is by any means brought about without the presence of other substances, the result is a certain quantity of hydrogen and a mass of finely divided carbon.

This dissociation can be effected in a body of acetylene gas at atmospheric pressure by the detonation therein of a small quantity of fulminate of mercury or other violent explosive, AND BY NO OTHER MEANS.

Heat, flame, the electric spark or the electric arc itself will not, according to the most careful experiments, produce an explosion under these conditions.

When the gas is condensed, however, it becomes,

with each increment of pressure, more and more unstable, and, in consequence, more easily exploded until the point of liquefaction is reached, when it becomes as dangerous as the high explosives.

The disastrous results which have invariably followed the attempts to liquefy acetylene should be sufficient warning against this procedure.

The only place where there is any excuse for compressing acetylene is in the chemical laboratory, where its properties are being studied by those skilled in dealing with unstable compounds, and where explosions are expected and provided for as a matter of course.

Taking it for granted that, until the dangers attending the use of liquid acetylene have been overcome, the gas under a pressure only slightly above that of the atmosphere will be used in machines for industrial lighting, we may state that, so long as acetylene is unmixed with any other substance, it cannot be exploded by the means usually at command.

An admixture of air with acetylene at once alters the case, for then we have the same conditions which determine the explosion of a mixture of the ordinary illuminating gas with air.

The two gases then behave in nearly the same manner, becoming more and more inflammable as the proportion of air increases until the mixture contains about one part of gas to four of air, when it becomes explosive.

The mixture remains explosive until the propor-

tions are one of gas to twenty of air, after which the dilution is too great for the propagation of flame.

In each stage the acetylene mixture is somewhat more dangerous than the house-gas mixture, simply because its explosion in each case is rather more violent. With a properly constructed generator, however, there should be no chance for the admixture of air with the gas in any proportion, no matter how small and apparently harmless; and, since many generators obviate entirely the admission of air to the system at the same time that they fulfil all the other requirements of successful gas-production, there can be no excuse for taking the slightest risk on this point.

ACETYLIDE OF COPPER.

The presence of ammonia in the gas favors the formation in the gas fixtures of this explosive salt. Well-washed gas should not combine with the small proportion of copper found in the ordinary fixtures. The substance is not easy to make, even in the laboratory, and the amount which could by any chance form in the fixtures is very small.

The use of copper should, of course, be debarred for any part of the system, and especially for the generator or gasometer.

TOXIC PROPERTIES.

A most elaborate series of experiments conducted in France upon men and various lower animals has shown conclusively that acetylene is slightly less

poisonous than the ordinary coal-gas in general use.

In experimenting upon dogs, it was found that, when the animals were removed from the influence of acetylene before they had been fatally poisoned, recovery was more rapid than when they were subjected to the effects of ordinary illuminating gas under the same conditions. An examination of blood samples taken every few moments showed that acetylene was rapidly eliminated from the system.

It was also found that fatal results were not produced by the prolonged inhalation of acetylene and air mixtures unless the gas existed in the proportion of more than twenty per cent.

The author may say that, while he is unusually susceptible to the effects generally produced by inhaling noxious gases, he has experienced no inconvenience whatsoever from breathing day after day an atmosphere rich in acetylene.

The danger to be apprehended from leaving the tap of a burner carelessly turned on is too remote to require serious consideration, since the leakage of half a foot of acetylene an hour would require, in an air-tight room eight feet square by eight feet high, fifty hours to produce a mixture of only five per cent. of gas.

The odor of acetylene is so peculiar that a very small leak is quickly noticeable. The odor, which is quite indescribable, is decidedly unpleasant, reminding one somewhat of garlic, or onions.

The products of the perfect combustion of acety-

lene consist solely of vapor, of water, and carbonic acid. In the case of incomplete combustion, in addition to these products, carbon monoxide, carbon, and hydrogen are produced.

The latter statement is equally true of any of the combustible illuminants, but the amount of carbon monoxide given off from the acetylene flame of the standard burner will be only one-tenth part of that from ordinary gas.

Experiments similar to those mentioned above have shown that animals are affected in about the same degree by inhaling the products from the combustion of equal quantities of acetylene and illuminating gas.

In the case of neither gas need any fear be entertained of the effects of inhaling the products of combustion of burners used for lighting. Cases of injury from this cause have happened, indeed, with illuminating gas, but only when used in large quantities, for heating, in a gas stove without proper provision for ventilation.

EFFECTS UPON THE EYES.

When the incandescent electric lamp came into use there was a general complaint that it "hurt the eyes." Later, the Welsbach mantle suffered under the same imputation.

One rarely hears either blamed for eye injuries at the present day.

The intensely bright light of acetylene will cer-

tainly be more than either of the others the object of a similar complaint.

A careful observation of the advent of all these lights has led the author to believe that, so long as a light is a novelty, and so long as individuals, prompted by curiosity, continue to look directly at the flame or other source of light, they will quite naturally be temporarily dazzled and partially blinded.

As soon as the novelty wears off and they are content to look at the objects illuminated, the complaint ceases to be heard.

Man for some thousands of years has had for his type of light the sun, and it is without doubt true that the sunlight is yellow. He takes most kindly to a yellow light, which is the reason the electric arc is so unpleasant, with its bluish tint and moonlight effect, and also the reason that the Wellsbach seems green to most of us. As a matter of fact, the acetylene flame is very like sunlight, and its effect on the eyes cannot but be beneficial, on account of its perfect steadiness.

The only disagreeable feature is, that from its small size, it casts a rather sharp shadow, which makes it unpleasant when burned without a diffusing globe or shade.

ELECTRIC FURNACES.

EVER since the beginnings of chemistry, the followers of that science have sought means for producing intense heat.

A charcoal fire urged by bellows or an alcohol flame intensified by the blowpipe, was used for this purpose by the early experimenters.

Then came, with the advent of illuminating gas, the Bunsen burner and the blast lamp in various forms as an important step in advance, and finally the oxy-hydrogen jet with which platinum and iridium could be fused.

Each improvement led to increased knowledge of the more refractory substances, but investigators still longed for a source of heat, which not only would be more intense, but which should be free from the disadvantages of a highly oxygenated flame. The extreme temperature of the electric arc had long been known and had been utilized in a small way in researches upon refractory materials in conjunction with spectroscopic analysis. During the past few years, however, the production of electric currents of immense quantity has become an established industry, and it has been possible to so magnify the small arcs of a decade ago, that an entirely new and most important piece of apparatus has been

developed. The result is seen in the electric furnace, which may vary in size from a small crucible, in which is maintained the arc of an ordinary street light, to those huge creations of the carbide works, where a thousand horse power of energy is converted into the sun-like radiance which fills the space between the carbons.

The electric furnace consists, in its simplest form, of a crucible of refractory material, within which an electric arc may be maintained between the ends of two carbon electrodes, which enter the crucible for that purpose.

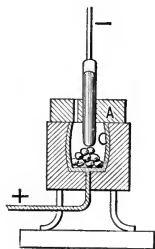

FIG. 1. Siemens Furnace.

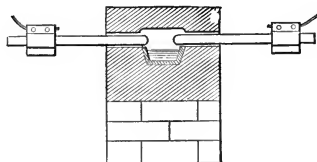

FIG. 2. Moissan Furnace.

The substance to be treated, generally in the form of grains, or in powder, is placed in the crucible in such position that it may be traversed by the electric arc, to whose intense heat it is subjected. The electrodes are sometimes placed in a horizontal position, sometimes vertically, and, again, inclined.

When horizontal, they may enter the crucible

through holes in its wall, or the crucible may be so shallow that they pass over its upper edge.

When vertical, the lower electrode may enter the bottom of the crucible through a hole, or may consist simply of a block of carbon laid on the bottom, or the bottom of the crucible, or the crucible may itself be the electrode, provided it is a conductor of the current, while the other electrode de-

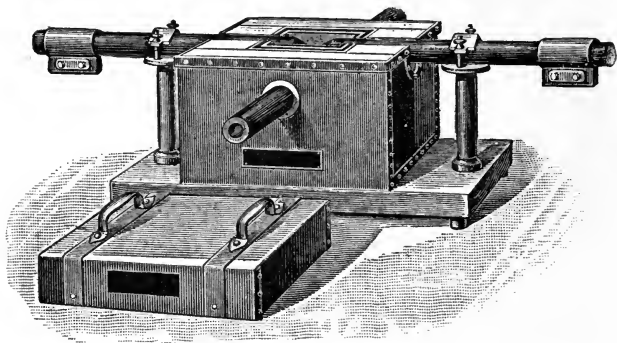

FIG. 3. Moissan Furnace.

scends through a hole in the cover when a closed crucible is used, or is guided centrally of the crucible by external mechanism in the case of an open furnace.

The Siemens furnace, Fig. 1, has a graphite crucible embedded in a mass of refractory material intended to prevent radiation. The crucible forms the lower electrode. There is a vent for the gases.

The upper electrode is operated by a magnified arc-lamp mechanism.

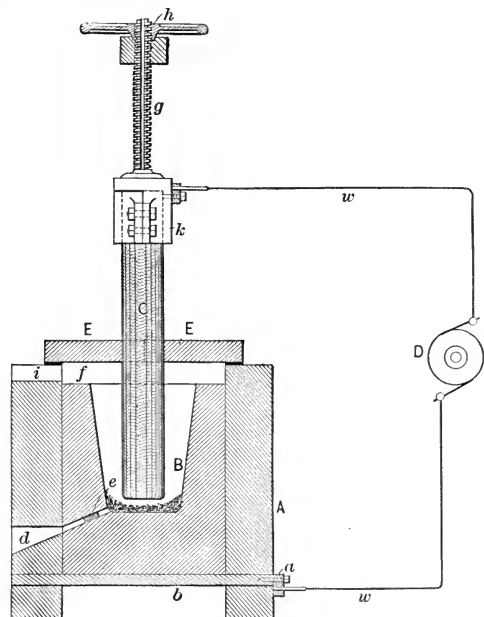

FIG. 4. Willson's Furnace.

The first Moissan furnace, Fig. 2, has horizontal electrodes manœuvred by hand. The crucible is so shallow that the electrodes pass over its upper edge.

The second form of Moissan furnace, Fig. 3, is like the first except that a hole is cut at right angles to the electrodes entirely through the furnace, near the bottom of the crucible. By inclining

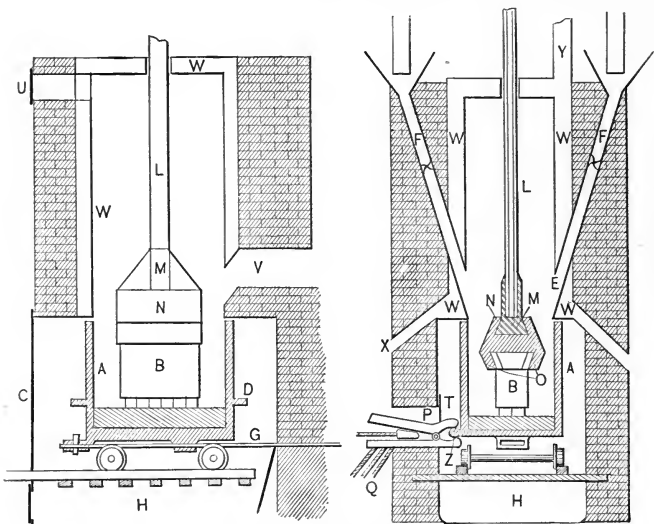

FIG. 5. King Furnace.

the furnace, it may be made continuous in action. The charge is fed in at the upper end of the cross-hole, and, after passing through the crucible, the product issues at the other side.

Willson's furnace, Fig. 4, has an outer casing

of brick (A), a crucible of carbon (B), a lower electrode of broken carbon, an upper electrode (C), with a wheel and screw h, g, for moving it, a tap-hole (D), and an iron base-plate, to which one pole of the generator is connected.

The King furnace, used at the carbide works at Niagara, N. Y., is on a more elaborate plan, although the additions to its mechanism are of importance only in giving ease of charging and removing the product. The crucible is contained in a small iron car, which may be run out on a track when desired and another substituted for it without loss of time. Suitable chutes allow the lime and coke mixture used for making the calcic carbide to be delivered to the furnace; flues carry off the gases of combustion. The car carrying the crucible is given a backward and forward motion during the action of the current, in order to distribute the contents and to make the action of the arc uniform. The upper electrode is formed of a number of carbons clamped into a massive connector.

King & Wyatt have patented a process for forming calcium carbide, in which, in lieu of an electric furnace, the mixture of lime and coke is placed in a heap on an iron plate which rests on the ground and forms the lower electrode. The upper electrode is supported on a light crane and is lowered down through the centre of the pile.

The carbide forms as a nugget in the centre of the mixture, from which it is removed by means of a pair of tongs.

Some furnaces are provided with movable bottoms for dumping the charge. Others have a tap-

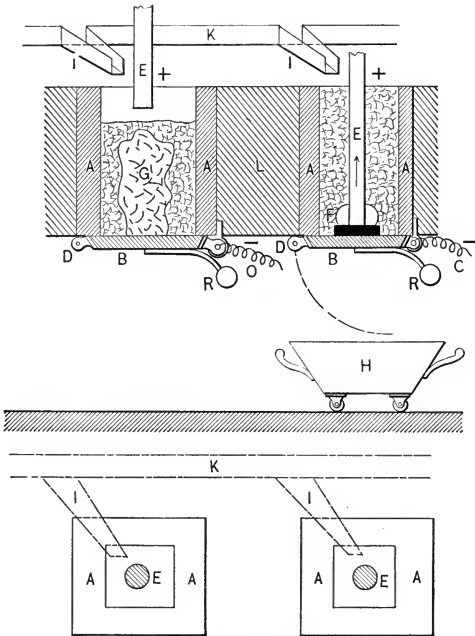

FIG. 6. Bullier Furnace.

hole for drawing off the molten carbide, but the best practice seems to consist in starting the furnace with the arc at the bottom, raising the electrode.

from time to time, and allowing the carbide to build up in the shape of a block until a considerable thickness is obtained. The current is then shut off, the upper electrode drawn out of the furnace, and

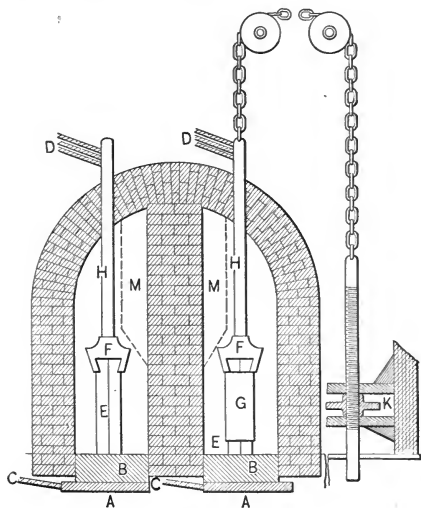

FIG. 7. Furnace used at Spray.

the crucible removed for cooling, while a fresh one is put in place and the electrode lowered.

The Bullier furnace, Fig. 6, is one having a dumping bottom. The sides are vertical, of fire-clay. The iron bottom serves as the lower electrode. The upper electrode is, as usual, of carbon, which

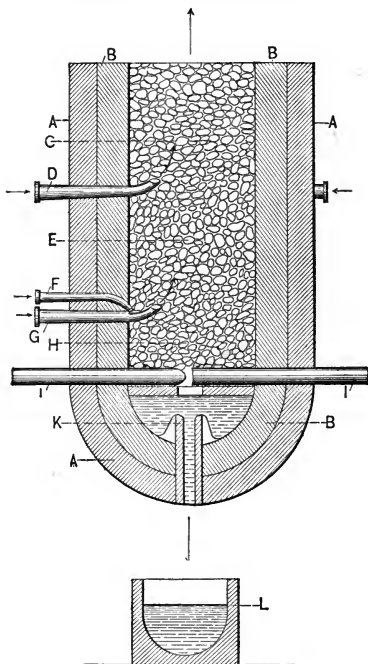

FIG. 8. Pictet Furnace.

penetrates the centre of the mass of lime and carbon contained in the furnace. As it is raised, there is formed about its end a cavity, into which the contents of the furnace fall, little by little. The block

of carbide, which occupies the centre of the mass at the end of the reaction, is dropped into a car by opening the bottom of the furnace.

The furnaces used in the carbide works at **SPRAY**, Fig. 7, are of the Willson type, but are double, and are covered by an arched flue, through which the gases escape. The carbons are composed of six blocks, each four inches square and a yard long, held in a clamping head and bound together by an iron sheath. In this arrangement, each furnace must be allowed to cool before the calcium carbide is removed.

M. Raoul Pictet has proposed a furnace, Fig. 8, in which the mixture of lime and coke is acted on, first, by a current of heated air at D, then by an oxy-hydrogen flame, G, as it reaches a lower level, and finally by the electrodes I, I, which melt the carbide. A hole in the bottom of the furnace allows the product to drop through into a receptacle, L.

This is, apparently, an unsatisfactory method, because the coke must be in excess in order to compensate for that burned out of the mixture, and the ash which results from the combustion materially interferes with the proper formation of the carbide.

Several attempts have been made to produce a continuous furnace, but, as yet, with unpromising results.

The continuous process would certainly be a gain in the economical production of carbide, if it could be made to work successfully.

A small portion only of the coke and lime would

be under action at a time, which, as soon as converted, would be automatically removed from the furnace; the necessity of maintaining the mass of carbide at a high temperature until all was converted would be obviated, and the loss of time in recharging furnaces and waiting for the carbide to cool would be avoided.

A CONTINUOUS ELECTRIC FURNACE.

SINCE the foregoing chapter was written, Mr. C. S. Bradley, of New York, has patented a continuously-acting electric furnace, which seems to satisfy perfectly the conditions of uninterrupted carbide production.

The description of this furnace (Figs. 9 and 10), and its operation is taken from the patent specification at considerable length, because, in a general way, it is an excellent account of the manner in which carbide is produced :

“The object of the invention is to permit a continuous and uninterrupted operation of the furnace, and withdrawal of the product, and to protect said product from the action of the air when at a high temperature.

“The furnace is especially designed for employment in the manufacture of metallic carbides. It comprises a receptacle for the charge to be operated upon, in which it inserts an electrode, means being provided for continuously moving the receptacle with relation to the electrode so as to bring fresh portions of material under the action of the electric current. The construction which it is pre-

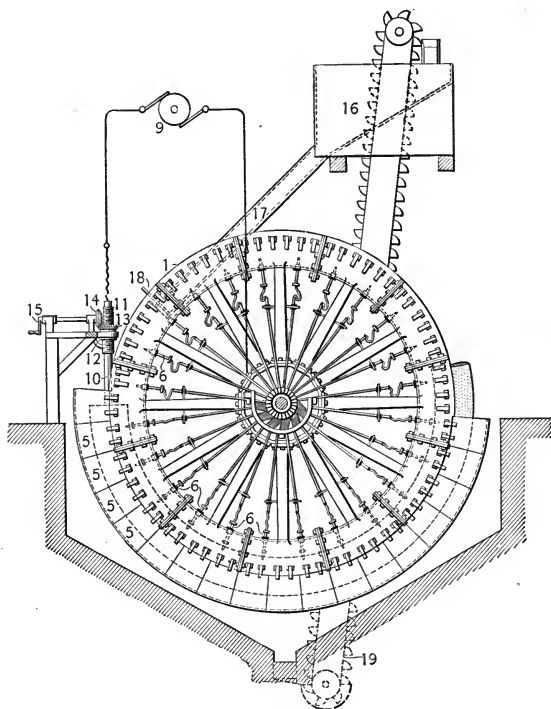

FIG. 9.

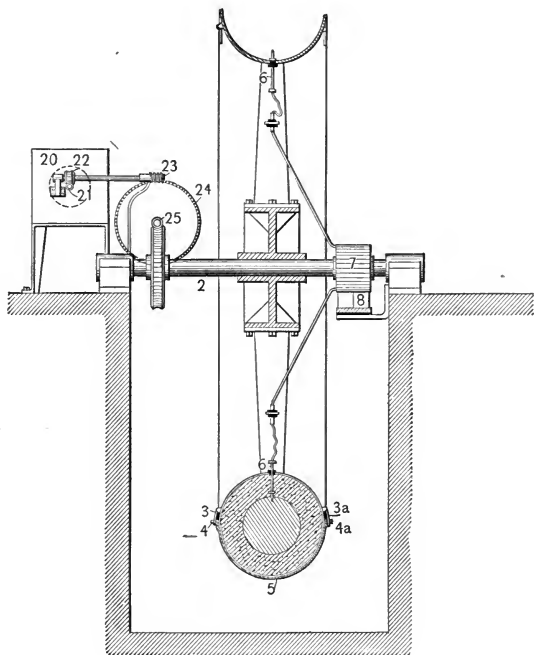

FIG. 10.

ferred to employ comprises a rotary wheel or annulus, into which projects at one side an electrode, and provided with means for preventing the material from spilling, and means for supplying fresh material to be acted upon by the current, and facilities for removing the product, the whole being so arranged that the operation may be carried on in an uninterrupted manner, the furnace constantly forming fresh additions to the product and permitting the latter to be removed as frequently as may be necessary. The wheel is preferably turned by power-driven machinery, and is provided with a hollow periphery, to which are attached over an arc covering the lower part of the wheel buckets forming throughout said arc a closed receptacle for the material to be operated upon. Said buckets are arranged to be withdrawn or opened when they reach the discharge-end of the wheel-arc. The material, in the form of powder or granules, is supplied to the side of the wheel which contains the electrode or electrodes. The electric arc, or the limits of the space within which the electric action on the material takes place, are wholly within the mass of pulverized material, so that a wall of unchanged or unconverted material will surround the product of the furnace, and the motion of the wheel in such direction as to surround the converted material by a body of unconverted material, and thus exclude air until the converted mass has become sufficiently cool to permit its removal and further treatment for packing for shipment or storage. In the formation

of a carbide of calcium, for example, an intimate mixture of ground lime and ground carbon is supplied to that side of the wheel-arc into which the current is introduced, and is fused, permitting the carbon and calcium to combine, and forming a pool of liquid carbide of calcium within the wheel-rim, which pool is surrounded by a mass of uncombined mixed carbon and lime, which acts as an efficient heat-insulator, keeping the walls of the receptacle comparatively cool. As the wheel turns, the pool is withdrawn from the neighborhood of the electric arc, or region of electrical activity, and the liquid carbide cools and solidifies under a superincumbent and surrounding mass of material, which prevents access of air and thus prevents wasteful consumption of carbon by combustion. Thus a core of solid carbide of calcium is formed within a granular or pulverized mass of material, said core growing in length as the receptacle recedes from the electrode until it emerges from the other end of the wheel-arc, when the removable sections of the wheel-rim may be taken off one at a time, permitting the pulverized material to fall away from the solid core of carbide, which may be broken off or otherwise removed periodically. Thus the formation of carbide goes on continuously without necessary interruption for recharging or removal of the product.

“Fig. 9 is a sectional view on a plane at right angles to the wheel-axis. Fig. 10 is a sectional view on a plane parallel to the wheel-axis.

“1 represents a wheel formed in sections and

bolted together, and having a horizontal axis mounted in boxes at or near the floor-level. The rim of the wheel is concave in cross-section, and is provided at intervals with pivoted latches (3, 3^a) to engage studs (4, 4^a) on semi-cylindrical sections of plate-iron (5) to support them on the wheel. Auxiliary plates of thin sheet-iron may be bent around the joint between the sections on the inside of the wheel-rim, to prevent the pulverized material from sifting through the cracks at the joints. The wheel may with advantage be made about fifteen feet in diameter, and the rim and plate-iron sections of such proportions as to form a circular receptacle of thirty-six inches in diameter. The inner wall of the wheel-rim is provided with holes at intervals to receive copper plugs (6) connecting with the several plates of a commutator (7) by conductors (6^a), on which bears a brush (8) connecting with one pole of an electric generator (9). The other pole of the generator connects with a carbon electrode (10) about four inches in diameter mounted in a sleeve (11) provided with a screw-thread on the outside, which engages an internally threaded sleeve (12) secured to a bevel-gear (13) meshing with a gear (14), on the axis of which is a crank (15) for adjusting the electrode. The electrode and its regulating mechanism are mounted on a framework adjacent to the wheel-pit, so that the electrode may be fed into the receptacle formed by the wheel-rim and the rim sections when partly consumed.

“ 16 is a feed-hopper provided with a spout (17)

projecting into the wheel-rim, and a gate (18) for regulating the supply of mixed material to be acted upon.

"The wheel-pit is preferably provided with sloping sides, so that any powdered material which drops from the wheel, at its discharging end or elsewhere, may slide by gravity to a conveyer (19), the buckets of which return it to the feed-hopper, to again pass through the furnace.

"The wheel is preferably connected with an electric motor by speed-reducing gearing. Said motor is shown diagrammatically at 20. The motor-shaft carries a worm (21) acting on a spur-gear (22), on the shaft of which is secured a worm (23) meshing with another gear (24), on the shaft of which is a third worm (25) meshing with a gear on the wheel-shaft. By this mechanism, a very slow speed of the wheel may be maintained, a complete revolution being made once in five days. In using the apparatus, the rim-sections are latched over the wheel-rim over an arc covering the lower part of the wheel, and the gate of the feed-hopper is opened. A charge of intimately mixed pulverized carbon and lime, in proper proportions to form carbide of calcium, falls into the receptacle around the wheel-rim and accumulates until the top of the electrode is immersed therein. The circuit of the dynamo-electric machine may then be closed and the electric motor thrown into operation. As the charge is moved away from the electrode, intense heat is created and the refractory material fuses, forming a pool of

liquid carbide of calcium, or other compound, depending on the nature of the furnace-charge. As the wheel turns, the pool gradually recedes from the electrode and slowly cools while inclosed within walls of refractory, uncombined material on all sides, the cool product forming a bottom for the liquid compound. Thus a continuous core of the product is formed, new rim-sections being added by a workman at intervals of a few hours. The electrode, at starting, should project well into the receptacle, and, as the wheel turns, the electrode rises relatively to the charge, and, when it reaches a point near the top of the rim-section, a new rim-section is hung on the wheel by means of the next set of supports, and a strip of sheet-iron is bent around the joint between the rim-sections. The gate of the hopper is then opened and the rim filled, or partially filled, with material. As this material in its powdered state is a very poor conductor of electricity as well as of heat, the immersion of the electrode does not interfere with the heating action. When a new rim-section is added on the electrode side of the wheel, one is removed at the other side. Thus the process continues until the solid core of the furnace product appears at the discharge-end of the wheel, when a rim-section is taken off and the powdered material falls into the pit, leaving a pillar of solid product projecting vertically, which may be broken off or otherwise removed. Solid carbide of calcium is a conductor of electricity, and the copper plugs make a good contact with the same, thereby constituting

the carbide itself one of the electrodes. The action of the commutator leads the current to a point of the carbide core close to the electrode, and thereby prevents unnecessary resistance, which would intervene if the plugs were more widely spaced. The conducting plugs (6), which are remote from the arc, help to carry the current, and thus heating of any one contact with the carbide core is reduced.'

GENERATION OF ACETYLENE

THE calcium carbide of commerce comes to us in air-tight cans of various sizes. The usual package holds either fifty or one hundred pounds. Upon opening the can, we find a heavy, dark-colored, stone-like substance in lumps of various sizes. The largest pieces are the size of one's fist, while the smallest are in the form of grains broken from the larger pieces in shipment and travel. The specific gravity of calcic carbide is 2.22. Its fracture presents a crystalline surface like that of broken cast-iron, but almost immediately loses its lustre when exposed to the air, becoming covered with a film of lime.

Upon dropping into a tumbler of water a piece of the carbide as large as a hickory-nut, a surprisingly violent reaction takes place. Acetylene is rapidly generated at the surface of the carbide, and, rising in the form of bubbles, throws the water into violent ebullition. A considerable amount of heat is liberated at the surface of reaction, which may boil the water in the tumbler if the piece of carbide is large.

The whole mass of liquid, which is rapidly whitened by the lime set free, is in such violent commotion and is so *soufflé* by the issuing gas that many bubbles carry away sufficient heat to break as

little puffs of steam before the water is near the boiling-point.

The reaction gradually subsides as the carbide is exhausted, leaving the water white and thick with lime.

After a time, the lime falls to the bottom of the glass in the form of a paste, from which the water may be decanted.

When calcic carbide and water are brought together, the calcium decomposes the water in order to unite with its oxygen, for which it has an affinity, while the carbon and hydrogen liberated by the reaction, finding nothing else on which they can seize, unite to form acetylene.

Chemically expressed, the reaction is:

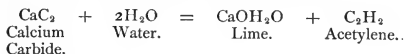

Taking into account the combining weights of the substances, we find that 1 kilogram of calcic carbide decomposes 562 grammes of water, and produces 1156 grammes of hydrate of lime, while 406 grammes, or 340 litres, of acetylene are set free.

That the generation of acetylene is attended by the liberation of a considerable quantity of heat may be illustrated by quickly dipping into water and withdrawing therefrom a small piece of carbide held between the thumb and finger. As the moisture enters the carbide, the temperature rises to such a degree that the piece must soon be dropped.

When water is supplied to a considerable portion

of calcic carbide drop by drop, the temperature of the centre of the mass may rise several hundred degrees, in which case the disengaged acetylene is partly decomposed into hydrogen and carbon. The bulk of the residuum from the generation of acetylene varies greatly, according to the way in which the carbide and water are brought together. If a piece of carbide is allowed to absorb moisture from the air, it gives off gas very gradually without changing materially in bulk. When, however, the carbide is thrown into a considerable quantity of water, the precipitated lime may be three or four times the bulk of the original mass.

Since all the commercial carbide contains impurities, the volume of gas liberated is never equal to the theoretical amount (340 litres per kilogram), but varies between 280 and 320 litres in the best samples.

Carbide giving less than 280 litres per kilogram, which is 4.66 cubic feet per pound, should be rejected, unless the price is based upon its yield of gas.

IMPURITIES OF CARBIDE AND PURIFICATION OF ACETYLENE

SINCE the lime and coke used in its manufacture are never pure, it is not to be expected that a pure product or gas will be obtained from the commercial calcic carbide. Varying results of analyses show that many kinds of impurities find their way into the carbide. Besides the acetylene, oxygen, hydrogen, sulphuretted hydrogen, phosphuretted hydrogen, and ammonia, have been found in the carbide. Sometimes one, sometimes another, impurity will be present.

The impurities are not very well accounted for, but it is supposed that there are some phosphates in the lime, as well as a small amount of aluminum sulphide.

At all events, the presence of these substances is what gives acetylene its bad odor, and, no doubt, are accountable, in combination with a certain quantity of carbon monoxide, and possibly some cyanogen, for the poisonous properties noticed in the gas made from the early samples of carbide.

The presence of ammonia is particularly unfortunate in any sample of acetylene, for it favors the formation of the explosive acetylide of copper in the gas fixtures. The ammonia and sulphuretted hy-

drogen may both be removed, however, by passing the gas in bubbles through water in a wash-bottle. In those machines in which the calcic carbide is thrown into a large quantity of water, the impurities are much more perfectly eliminated than they are in that class of machines in which the water is gradually fed to the carbide, because the temperature never rises appreciably, and the large amount of water through which the gas must pass washes it very thoroughly. The gas from this class of machine has less odor, and certainly burns with a brighter flame, than does that coming from the generators which add the water to the carbide.

When an attempt is made to put to actual use an acetylene generator in which the gas is generated from a considerable mass of carbide by the gradual addition of water thereto, either in the form of little streams or drop by drop, very serious difficulties are encountered.

In the first place, there is the unfortunate rise of temperature, which makes some kind of cooling jacket necessary for the generator, and generally involves a cooling coil immersed in water, through which the gas is delivered to the gasometer.

When a machine of this character is started with a fresh charge of carbide, little difficulty is met in regulating the water-supply automatically to flow to the carbide, and generate gas in proportion to the amount used.

After being in action a short time, however, the lime disengaged forms a protective and absorbent

coating over the blocks of carbide, which takes up the water as fast as delivered until it becomes saturated. It is then only that the water gets free access to the carbide.

Consequently, the machine responds slowly to the addition of separate increments of water. On the other hand, when the supply of water is shut off, the carbide, being hygroscopic, continues to absorb moisture from the wet lime, causing the evolution of gas to continue for a longer time than was intended.

This action causes irregularity in the working of the machine, and, when coupled with the fact that the hot lime absorbs a larger quantity of water than it can hold when it has cooled, makes machines operated on this principle unsatisfactory. The gas is, moreover, almost sure to be contaminated by the impurities caused by local heating of the carbide, and, if these be removed by washing or by chemical means, a deficient yield per pound of carbide is the result.

Those machines in which the carbide is alternately lowered into and removed from the water contained in a generator or in the gasometer itself are open to similar objections.

The present, also, the disadvantage of beginning operation with a brisk evolution of gas, which diminishes as the carbide becomes more and more exhausted, until, at the end of the operation, the disengagement of acetylene is too slow and feeble to maintain the necessary supply. In consequence,

the carbide must be renewed before it has been entirely reduced.

In some generators an attempt has been made to compensate for this inequality of production by enclosing the carbide in a conical basket of perforated metal or of wire gauze, apex down, so that as the action became feeble a larger surface of carbide would be brought into contact with the water.

In these machines the carbide, even when withdrawn from the water, is in a favorable position for absorbing moisture. A layer of oil covering the water materially improves their performance, as it prevents evaporation of water; and, when the carbide is lifted up through the oil, the water is to a great extent displaced and driven out of the reduced lime. Either one of the above types of machines is considerably simplified and has most of its objections removed by having a gasometer of sufficient size to contain all the gas disengaged from a charge of carbide. This, of course, makes the machine of inconvenient bulk, and involves the necessity of a separate building to contain the apparatus if it is of capacity sufficient for practical use in furnishing gas for illuminating a house of a dozen rooms or more.

The obvious advantage of a machine in which the carbide is all acted upon at once, called an "intermittent machine," over the continuous machine led experimenters first to multiply the number of generators connected with a single gasometer, and to devise means for automatically putting one after the other

into action, entirely exhausting the charge of carbide in each generator at each operation. Another device consisted in putting into a single generator a number of separate charges of carbide, each of which was acted on and its gas entirely disengaged in turn.

In all of these modifications, however, there is the disadvantage that at each charging of the generators a certain quantity of air is introduced into the system. Ordinarily, this proportion is too small to cause alarm, but it is quite conceivable that, in the event of the generator being nearly exhausted of gas, there is a time (at the beginning of its recharging) when the mixture contains sufficient air to be highly explosive. A due consideration of the dangers, disadvantages and inconveniences of machines of either of these varieties led to the development of what is certainly at the present time the most perfect system at command, *viz.*, the "carbide chute" generator, so-called.

This type of machine consists of a generator, either combined with or separate from the gasometer, of such size that it may hold a large quantity of water relatively to the amount of carbide to be acted upon.

Entering the side of the generator at a point below the water-level is an inclined tube or chute open at both ends, in which the water stands at the same level that it occupies in the generator. The arrangement is precisely like a tea-pot with its spout. The top of the generator is either sur-

mounted by a gasometer or it has a delivery-pipe for the gas. At the bottom, which is usually funnel-shaped, is a tap through which the pasty lime resulting from the gas-making is drawn off.

The machine is charged by dropping carbide in pieces through the chute, whence they descend to the bottom of the generator, causing a lively disengagement of gas. This, after bubbling up through the large mass of water, by which it is thoroughly washed, enters the gasometer or the delivery-pipe.

Since the quantity of water is great, the temperature never rises more than a few degrees; and since the carbide is dropped through the water-seal directly into the generator, no air is introduced into the system. The carbide may be fed by hand to the machine, or may be automatically dropped from a "distributor" containing pockets, which are brought successively into position over the chute by the descent of the gasometer. The lime resulting from treating carbide with so large a quantity of water is very considerable in bulk, but is correspondingly subdivided. It settles readily to the bottom of the water, but remains sufficiently pasty to be drawn off through a large tap or gate-valve. An occasional addition of water to the generator and a periodical drawing off of the lime constitutes all the attention needed other than to keep the distributor filled with carbide.

Various examples of each type of generator are given hereafter, when the peculiarities of each will be set forth.

GENERATORS.

IN the earlier stages of experiment with acetylene, before suitable burners were devised, it was considered necessary to mingle a certain proportion of air with the gas, either in the generator or in a special mixer, before it reached the distributing pipes. Since this practice has been entirely given up, on account of its danger, it will be unnecessary to more than mention such apparatus as something to be carefully avoided.

The same may be said of such generators as deliver the gas under considerable pressure, and of the various machines for reducing it to a liquid form.

Generators for the production of acetylene gas under the very slight pressure necessary to send it to the burners may be divided broadly into three classes, each of which has many modifications, and in each of which the various operations have been performed in devious ways.

Some of the variants scarcely come under the classes into which they have arbitrarily been divided, but, as they are not numerous, it seems unnecessary, so long as they retain salient features of any one type, to classify them separately.

The three types of generator may be classed as follows:

1st. Generators which have the generator and gasometer separate, and in which the gas is produced by supplying water gradually and in measured quantity to a considerable portion of carbide contained in a closed vessel.

2d. Generators which contain both the carbide and water, with means for immersing and withdrawing the carbide successively by a relative movement of the carbide and water.

3d. Generators provided with means for dropping measured quantities of carbide into a large volume of water.

GENERATORS OF THE FIRST CLASS.

Dickerson Generator (Fig. 11).—In this generator, which was one of the first invented, a gasometer is connected by a pipe to a sealed chamber containing a layer of carbide and having within it a perforated tube communicating with a reservoir of water and closed by a measuring stop-cock. This cock is operated by the rise and fall of the gasometer bell. The plug of the cock is hollowed out and has two slots at right angles to each other. When one slot is in a vertical position, it is open to the water-reservoir. Water enters and fills the hollow of the plug. Upon the descent of the gasometer bell, the cock is rotated, the reservoir is shut off, and the second slot is brought into position to deliver the water in the hollow plug to the tube which conveys it to the carbide. As the gasometer rises, the

parts resume their first position and the operation is repeated until the carbide is exhausted. In order to deliver the water quickly to the carbide, the axis of the cock is provided with a weighted lever, so that when the cock is turned past a certain point the weight falls, turning it the rest of the way.

Generator of Janson and Leroy (Fig. 12).— This generator has a gasometer which is provided with two retorts or generating chambers, either one of which may be put in action or cut out by means of the cocks *r, r, C, C*.

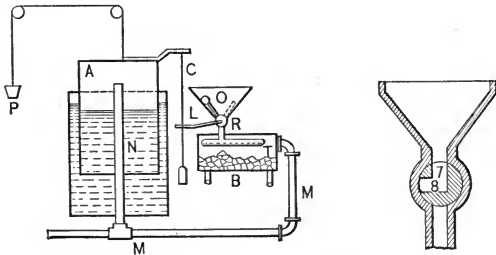

FIG. 11. Dickerson's Generator.

An elevated tank of water communicates with the retorts by means of a tube containing a cock (R) kept closed by a spring. When the bell of the gasometer falls, a finger (D) with which it is provided opens the cock (R) and delivers water to one of the retorts. When the carbide in that retort is exhausted, the further descent of the bell rings an electric alarm, warning one to so turn the cocks as

to put the other retort into action. The first may then be disconnected, opened, cleaned of lime and recharged.

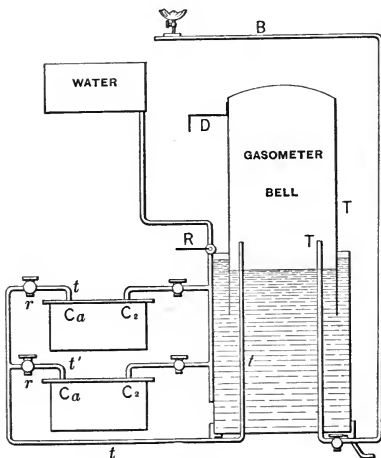

FIG. 12. Janson and Leroy Generator.

The Bon Generator (Fig. 13) has a cock (r') operated by the rise and fall of the gasometer bell. A reservoir of water is placed on top of the gasometer and is provided with a water-gauge, so that, if a quantity of water is placed therein sufficient to decompose the carbide placed in the generator, an inspection of the gauge will show how nearly the charge is exhausted. The water descends by the

tube G and falls into a funnel (G') which conducts it by an inverted siphon to the carbide.

The carbide is placed in a pan (F) which is divided into compartments, numbered from 1 to 12 in the

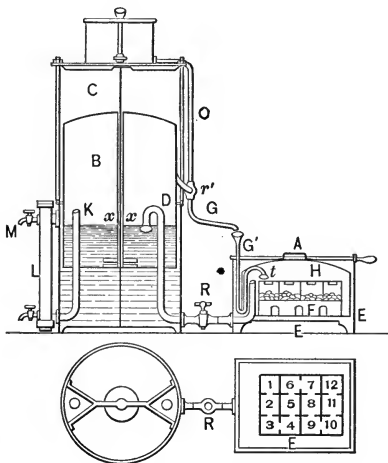

FIG. 13. Bon Generator.

lower figure. Each compartment contains such a weight of carbide that the gas which it disengages will just fill the bell of the gasometer. If too great a quantity of water enters, it attacks the carbide in the first compartment only, so that there is no over-production of gas. Each compartment communi-

cates with the one before and the one following by means of a notch cut in one of its walls.

The water falls always into the first compartment, and, after the carbide it contains is decomposed, overflows into the next, and so on until all are successively filled. The pan containing the carbide is placed in an outer case containing water, which keeps it cool and acts as a seal in conjunction with the bell (H) held in place by a bar (A).

The gas enters the holder by a curved pipe (D) below the water line; it is washed by bubbling up through the water. A dryer (L) in the delivery-pipe may be filled with any absorbent of moisture or, as is sometimes the case, with lumps of carbide, which not only absorb the moisture but give off additional gas.

The Souriou Generator (Fig. 14).—This is provided at its base with a circle of retorts each containing sufficient carbide to generate gas enough to fill the gasometer.

Each retort is provided with a weighted lever controlling its water-supply, and each lever is normally held in position by a latch to close the cock which it operates. The latches are successively opened by the motion of the gasometer bell.

The Clausolles Generator. This has a single retort surmounted by a reservoir of water. A cock connecting the two is operated by the gasometer bell as it rises and falls. In this machine it is intended that the admission of water shall be proportional to the gas used.

The only novelty is a tube open at both ends, which projects from the top of the bell and extends downward to nearly its entire depth. In case of

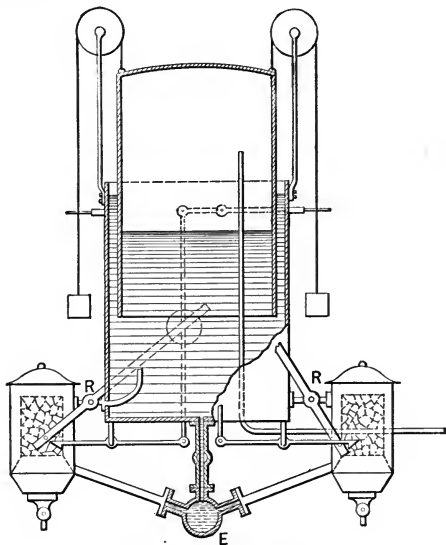

FIG. 14. Souriou Generator.

over-production, the lower end of the tube is lifted out of the water before the bell is quite full, allowing the surplus gas to escape. By this means the spattering of the water, which attends the escape of gas from the under edge of the bell itself, is avoided.

The Voigt Generator (Fig. 15) differs from the last only in having the controlling cock actuated by a rack and gear-wheels, and in passing the gas through a cooling coil on its way to the holder.

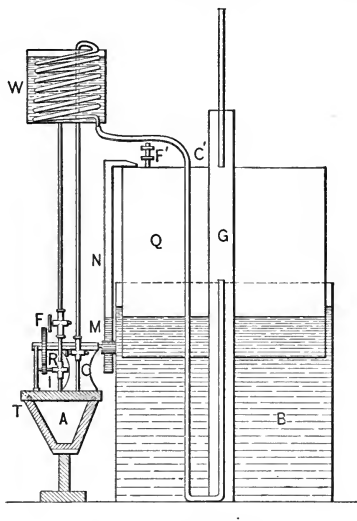

FIG. 15. Voigt Generator.

The Humilly Generator (Fig. 16) is an ingenious arrangement of this type of machine. The gasometer in this machine is small and acts principally as a regulator. The generator consists of a tightly closed bell weighted with a lead disc (p).

Within is a basket of carbide, through which a tube (C) projects and is surmounted by a conical distributor (I). The retort is immersed in the water contained in the outer vessel by which it is kept cool. Some of the water finds its way up to the tube C,

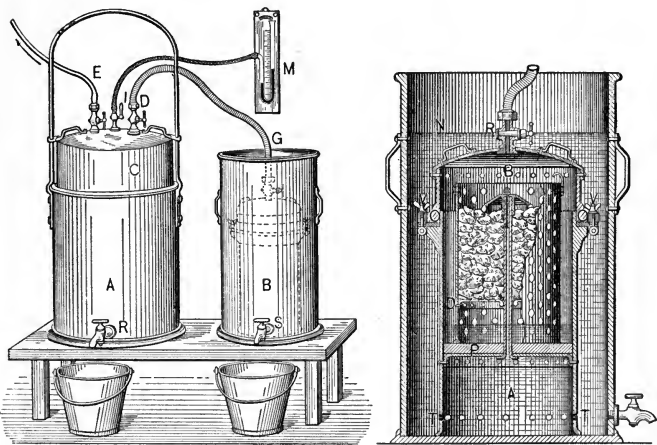

FIG. 16. Humilly Generator.

whence it runs down the inclined surface of the cone I and drips upon the carbide. As the pressure increases the flow of water is arrested.

An improved form of this generator is shown in Fig. 17, in which the carbide is divided up among a number of pots having holes through their sides at

different levels. By this device the water enters one pot after another, so that only a small amount of carbide is acted upon at a time.

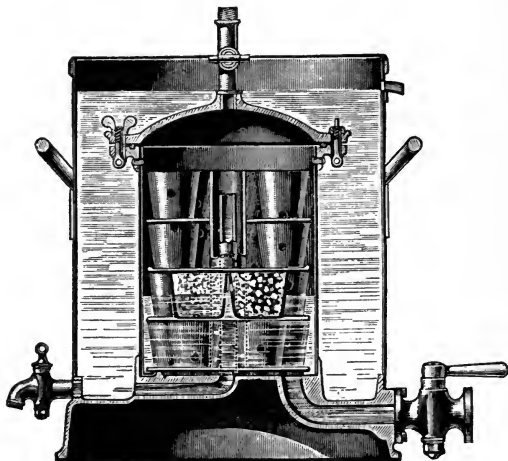

FIG. 17. Humilly Generator.

The Exley Generator (Fig. 18), which has been much used, is on a similar principle, but has the carbide contained in two retorts (R, R') fastened to the side of the water-vessel A , with which they communicate by means of tubes (T, T).

In action, the cock v is closed, while v^1, v^2, v^3 are open. The water coming through the hole O passes by the pipe T to R' , where it attacks the car-

bide. The gas generated passes by way of the pipes D' , D to the upper part of the reservoir (A), where it displaces the water, forcing it into B by way of the drop-tube P . As gas accumulates in A , the level of the water sinks until the hole O is reached,

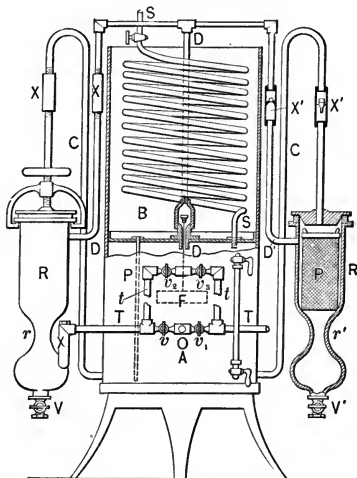

FIG. 18. Exley Generator.

when no more can enter the retort. The gas is led to the burners through the cooling-coil (S). When the contents of retort R' is exhausted, the water in A rises, as gas is used, until it flows through the branch pipe and open cock (v^2) to the retort (R), where the same action takes place as before.

When this happens, which may be determined by the reading of the water-glass attached to the apparatus, the first retort is opened and recharged. During this process the cocks v^1 , v^2 are closed.

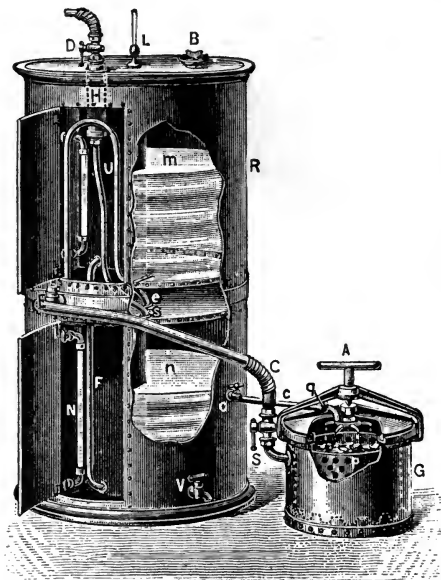

FIG. 19. Gillet & Forest Generator.

Safety-pipes having valves (X) to prevent return of the gas to the retorts are provided. There is con-

siderable unnecessary complication about this generator, and, as the level of the liquid determines the pressure of the gas, a fluctuating delivery results.

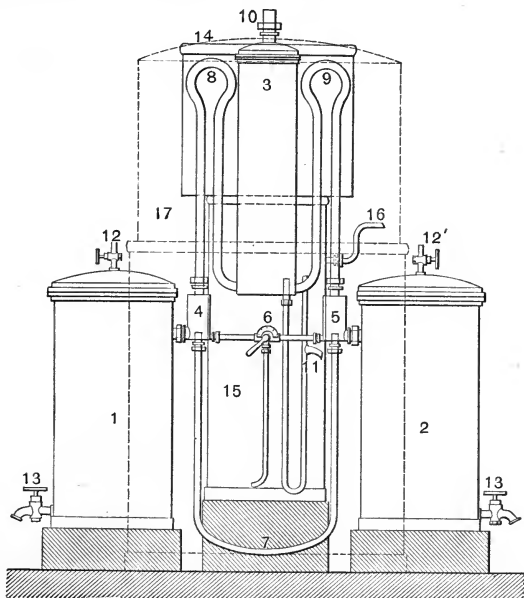

FIG. 20. Deroy Generator.

The Gillet & Forest Generator (Fig. 19) operates on the same principle of displacing the level of water contained in the gas-holder. The retort

(G) contains a basket of carbide (P), and is closed by a cover and screw (A). Water enters by the small tube c , while gas leaves by tube C. As gas accumulates in the holder, the water is forced into the upper section. When the level of the water in the lower part reaches the mouth (o) of the tube (c), the flow ceases and a fairly close regulation is for a time effected.

The Derooy Generator (Fig. 20) is said to give a very regular output of gas. It consists of a gasometer (15) with bell (17), to which are connected two retorts (1, 2) by curved pipes (8, 9), which convey the gas first through a washer (3).

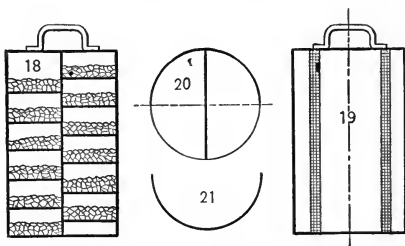

FIG. 20A.

Water from a reservoir, fed from a second reservoir (14), enters retort 1 by way of the cock 6. The retorts contain carbide subdivided into separate cells (Fig. 20A) by a series of discs and rings, so that the different portions are at various levels. The water, as it rises in the retort, can reach only one cell

at a time, and it is intended that the contents of each cell shall, when decomposed, fill the bell with gas.

The supply of water to the carbide is controlled by the pressure in the retort and the level of the liquid in the reservoir, which is provided with an overflow (16). When retort 1 is exhausted, the

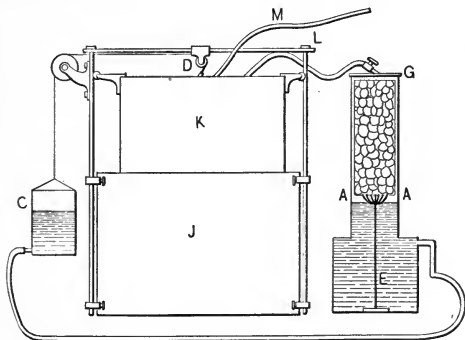

FIG. 21. Chesnay & Pillion Generator.

water rises until it flows by the curved tube 7 to retort 2. No. 1 may then be recharged.

Before that is done, the cock 6 is turned to supply directly retort 2.

The Generator of Chesnay & Pillion has the usual arrangement (Fig. 21) of retort and gasometer.

The novelty which makes it worthy of notice is that the reservoir of water is raised and lowered by the bell, being suspended therefrom by a cord and connected to the retort by means of a rubber

tube. T. O'CONNOR SLOANE, of New York, has made a very pretty application of the same idea for lantern projections. It may be here remarked that the acetylene light answers admirably for the magic lantern, and, with a small generator of this type, is convenient and cheap.

In **Ragot's Generator** a very ingenious arrangement is shown.

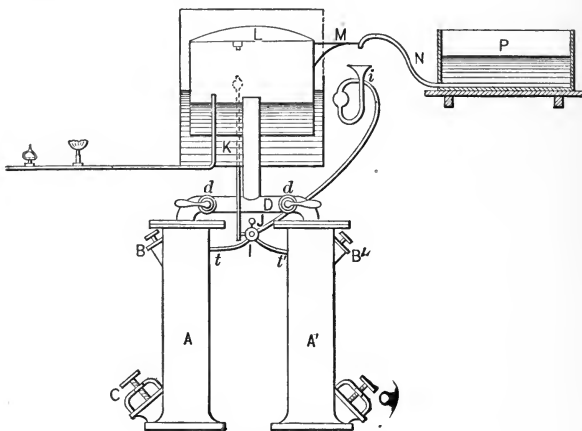

FIG. 22. Ragot's Generator.

In order to avoid the varying weight of the full and empty reservoir of the last machine, he supports the reservoir of water and moves the flexible outlet leading from it by the rise and fall of the bell. This

is illustrated by Fig. 22, which also shows the pair of retorts used and the means for putting either one into operation alternately.

La Phare Generator.—In this generator (Fig. 23) an elevated water-supply (E) is connected by a

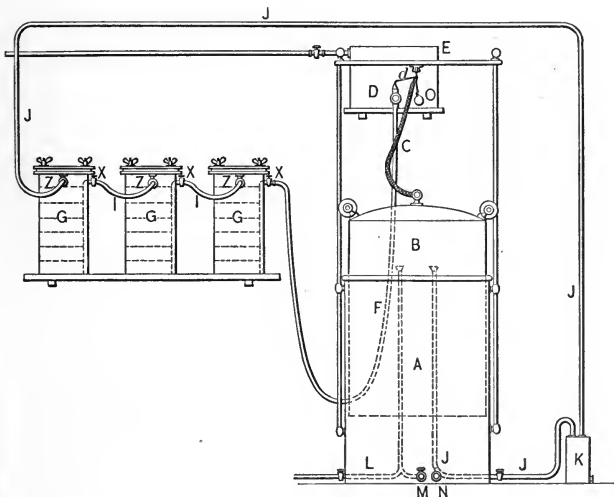

FIG. 23. La Phare Generator.

flexible tube to the first of a series of retorts (G, G) containing carbide in superimposed pans. Each retort is connected by a rubber tube to the next in series, and the last by way of a wash-bottle (K) to the gasometer. A cock (D, D), normally held closed by a

spring, is opened by a cord (C), which is pulled when the gasometer bell sinks to a certain point. Water enters the first retort, from which the gas passes by way of the opening Z through the other retorts to the gasometer. When the first retort is exhausted, the water overflows into the second, and so on. The first retort is then disconnected from the series and the water-tube connected to the second. A water-supply pipe and float-valve keep the reservoir D always full.

The Springfield Generator.—This machine, which was perhaps the first to recognize the desirability of storing acetylene in an underground gas-holder, is shown in Fig. 24.

This generator is of the intermittent type, requiring to be recharged with carbide each time the gas-holder is emptied. Owing to the unequal pressure upon the gas in the holder, corresponding to different water levels, a pressure-regulator is required in the main delivery-pipe.

A and A' are iron tanks, each having a capacity sufficient to hold the gas generated by one charge of the generator.

B, the generator, is a cast-iron cylinder.

C, the lid or cover of the generator.

E is a gallery supplied with mercury, in which the lip of the lid is immersed when the generator is closed, in order to make a gas-tight seal.

F is a clamp for holding the lid shut, and forms the lever of the gas-cock (D). If desired, this may be secured with a padlock.

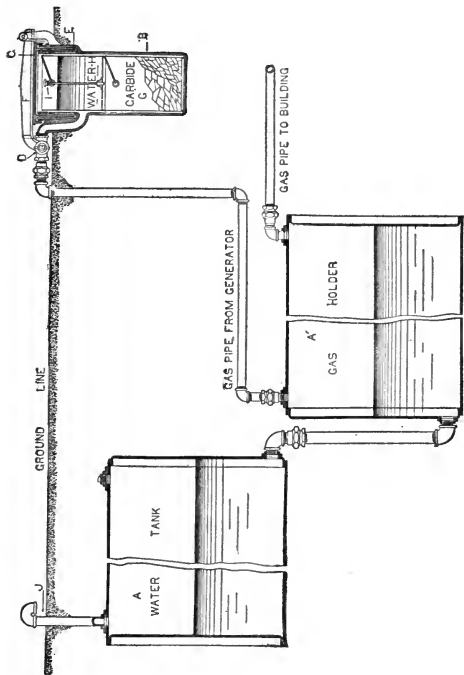

FIG. 24. Springfield Generator.

G is a galvanized iron pail or bucket, containing the carbide of calcium.

H is a similar bucket, containing water.

I is a handle, controlling a valve in the bottom of the water-bucket and reaching the top of the bucket.

The return bend (J) is screwed off and water is poured in until the lower tank (A') is full, leaving the upper tank (A) nearly or quite empty. This supply of water is permanent. This introduction of water will be accomplished best when the lid (C) of the generator is removed and the clamp (F) lies horizontal, which will furnish a vent for the air in tank A'.

The pail G, partially filled with carbide of calcium, is placed in the generator first. The handle I being turned, the water in the pail H will run slowly down into the pail containing the carbide, and gas will immediately begin to generate. The cover C should be placed in position and fastened with the clamp F immediately after opening the valve I.

The gas formed by the decomposition of the water in contact with the carbide will accumulate on the surface of the water in the tank A', and the water will all be forced up into the tank A. The tank A' will be full of gas, and the tank A full of water.

The gas is now ready for use.

A pressure-gauge is located inside the building lighted, at any convenient point from which may be determined by a glance, at any moment, how much gas remains in the machine. A pressure-regulator

located within the building lighted insures the delivery of the gas to the burners at a proper pressure.

The Napheys Generator.—In the upper section of the steel tank is suspended a cylindrical steel

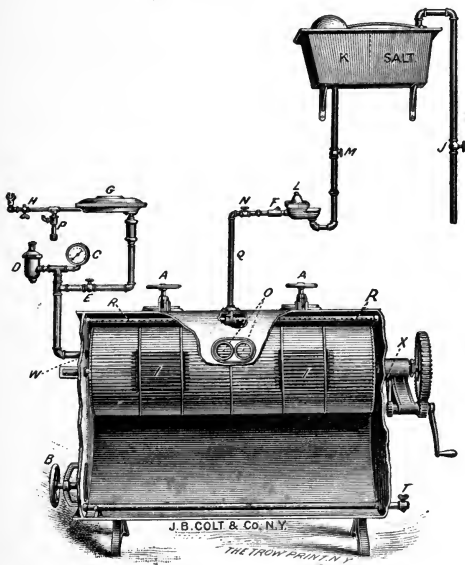

FIG. 25. Napheys Generator.

cage. The cage is supported by a shaft which passes through a stuffing-box (X) and has attached to it a large gear-wheel. This in turn is geared to a crank,

and turning the latter slowly revolves the cage. Carbide is placed into the cage through ports A, A, and the slide doors I, I, which are then slid back into place, and then the ports A, A clamped, so as to be air-tight.

The auxiliary reservoir K is supplied with water from any available source, either the city supply or house tank. Salt is placed therein to prevent freezing, if the water is exposed during cold weather. Water falling by gravity passes through cock M, automatic-regulator L, check-valve F, cock N, and pipe G to sprinkler-pipe R, R. The latter should be perfectly level, so as to spray all parts of the carbide evenly. As the water comes in contact with the carbide it is rapidly decomposed and acetylene generated. Cock T is then opened to allow the air contained in the generator to escape. This accomplished, cock T must be closed. The acetylene finds exit through pipe W, passing through valve E, and the gas-pressure regulator G to H, where house connection is made. It also operates the indicator C, and, if pressure should for any reason become too high, would escape through the safety-valve D. As the pressure rises in the tank it correspondingly rises in water-pipe Q and the automatic-regulator L. When a certain pressure is reached, the regulator L automatically cuts off the water-supply, preventing any further admission of water upon the carbide.

Each day the cage should be turned over. This allows the residuum (slaked lime) which has accumu-

lated on top to fall through the cage to the bottom of the generator. From there it is withdrawn through port B.

The openings in the safety-valve and mercury blow-off are to be piped out-doors. A whistle may be attached to the end of the pipes if desired, so that in case either are brought into operation instant notice will be given and the disarrangement stopped.

The Wallace Generator (Fig. 26) has been used to a limited extent in this country.

It consists of a cast-iron retort—shown at the left of the cut—closed by a door bearing upon a rubber gasket, a gasometer, water-supply kept at constant level by a ball-float valve, a cooling-coil within the reservoir through which the gas flows on its way to the holder, and a pair of water-seal safety devices, one below the retort and one at the bottom of the gasometer.

The generator is charged by placing in the retort a pan containing about fifteen pounds of carbide. The door is closed and the cock leading to the gasometer through the cooling-coil is opened.

The water-valve is then opened, allowing water to spray upon the carbide.

A heavy, annular weight suspended over the gasometer is lifted by the rising bell at a certain point in its travel. When this happens, the pressure of gas in the retort is somewhat increased, and, as the level of water in the reservoir is very slightly above the top of the retort, its flow is arrested.

A pressure-gauge is attached to the machine, which

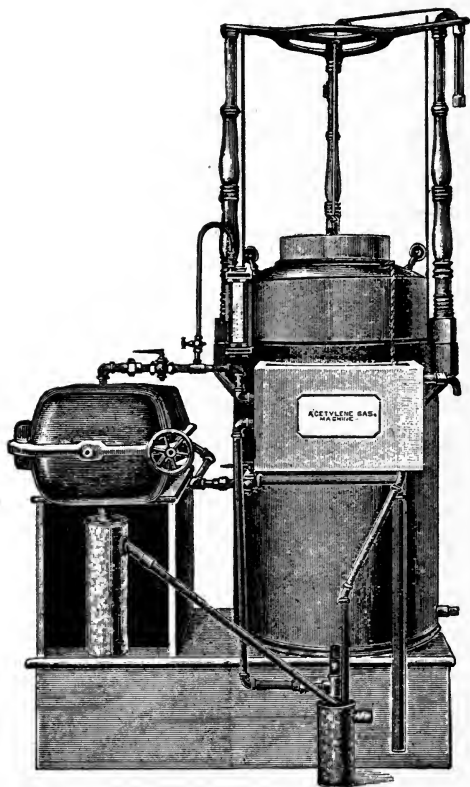

FIG. 26. Wallace Generator.

is also safeguarded against excessive pressure by the water-seals contained in the two safety-cans.

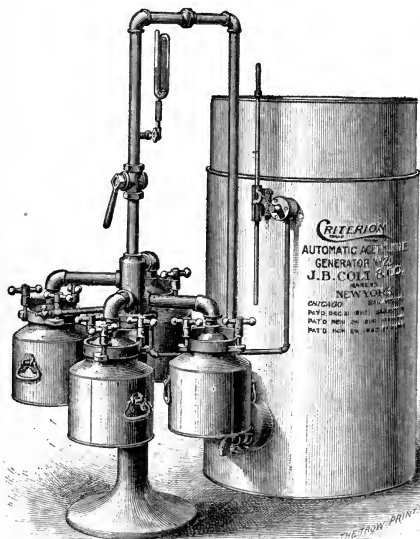

FIG: 27. The "Criterion" Generator.

The "Criterion" Generator (Fig. 27).—This generator consists of a stand for carrying the carbide-holders and a gasometer for regulating the supply of water, keeping the gas pressure constant and taking care of the surplus gas. A condenser

for cooling the gas is at the base of the gasometer. The water-regulator is placed on the side of the gasometer, from which the water supply is taken, except in large generators, in which a separate water tank is used.

The carbide-holders are made in various sizes and are attached to the stand by pipes which radiate from a central upright, but each holder is on a different level from the others; four, eight, or twelve of these holders, according to size, can be conveniently arranged in sets of four, one set above the other, the gasometer being of the same capacity for any number of holders of a given size.

As the gas is used, the gasometer descends, the water-regulator is opened and water is admitted to the stand and flows into one of the carbide-holders. In the small generators the gas passes into the stand by the same pipe through which the water enters the holder, then into the gasometer and to the burners. If an excess of gas is formed, the gasometer rises and the supply of water is automatically shut off.

When the carbide in one of the holders is exhausted, the water rises into the next holder.

In case of too sudden generation of gas the water instantly stops flowing into the holder, because the rush of gas over the water in the same pipe holds the water back and prevents the formation of gas until wanted.

SECOND CLASS.

Generator of Allemans & Stemmer (Fig. 28).—A funnel-shaped vessel (G), having a gas-tight cover, depends into a closed case (T). The carbide is

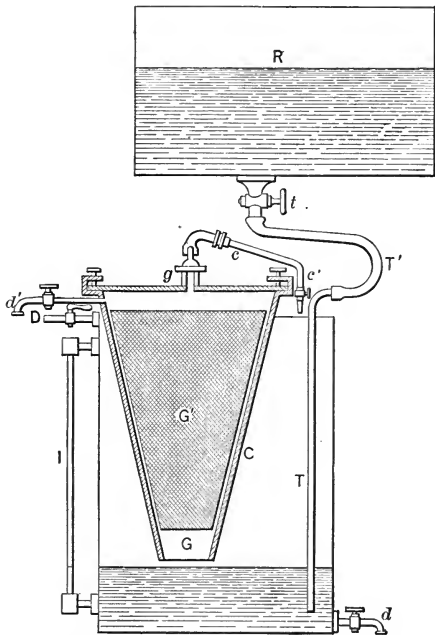

FIG. 28. Generator of Allemans & Stemmer.

inserted in a conical basket. Water from an elevated reservoir enters T until the carbide is reached, when the pressure of the gas generated regulates the supply. The conical mass of carbide is intended to equalize the production of gas by bringing a larger surface into action as the carbide is more and more exhausted.

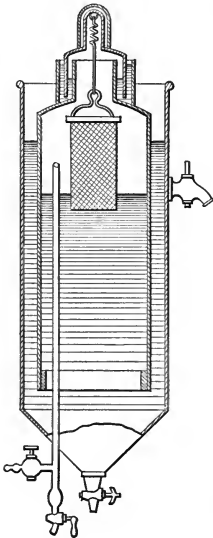

FIG. 29. d'Arsonval
Generator.

d'Arsonval has designed a remarkably good generator for experimental use. It consists (Fig. 29) of an outer case containing a bell. Within the bell is hung a basket of carbide, introduced through a water-sealed cover. The water in the gasometer is covered with a layer of oil. When the bell sinks, the carbide suspended from it enters the water, giving off gas, and, under a constant rate of use, it soon finds a position in which it remains stationary, the production being then just sufficient to

supply the demand.

When gas is no longer used, the production continues for a short time, the bell is lifted, and with it the carbide. The oil, as the carbide passes through it, displaces the water which had previously been

absorbed, preventing further action. When the carbide is lifted entirely out of the liquid, the layer of oil, by preventing evaporation of the water, keeps the moisture from slowly producing gas. Generators on the same principle. without the layer of oil,

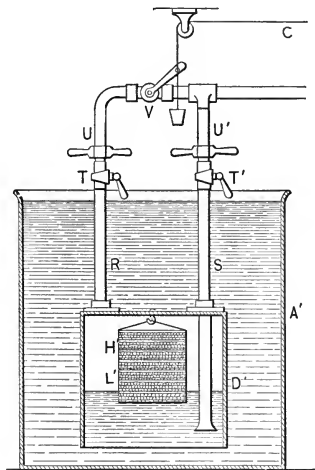

FIG. 30. Gabe Generator.

are much used for lantern-work, but the gradual evolution of gas when not in use is a serious drawback and is entirely overcome by this simple expedient.

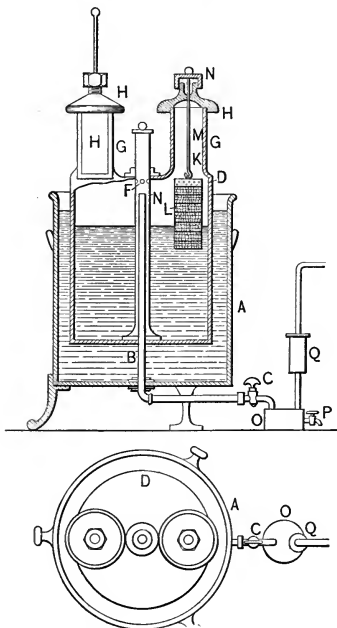

FIG. 31. Gabe Generator.

The Gabe Generator exists in two forms: The industrial model (Fig. 30) has a basket of carbide hung in a bell contained in a large outer case filled with water. The operation is obvious. The gas goes through a washer to a gasometer, or is

taken directly to the mains. In the smaller model (Fig. 31), the carbide is contained in a number of baskets in the top of a rising and falling bell. One after another is pushed down by means of the rod from which it is suspended until it enters the water. When all are exhausted, the generator must be put out of service while being recharged. The simplicity and cheapness of this type of machines recommend them to experimenters, but the fact that the bell must be opened and any gas remaining therein lost before recharging makes them unfit for practical application on an extended scale.

THIRD CLASS.

The carbide chute machine seems to offer the best solution of the problems involved in making a continuously acting generator, because in it the carbide may be added and the lime removed without admitting air or interrupting the production of gas. Moreover, since there is always a relatively large quantity of water surrounding the carbide, no heating takes place.

Some of the earlier generators of this class required the use of granulated or powdered carbide, and although this form is not now in vogue, these machines are interesting. They will be first described.

The Marechal Generator (Fig. 32) consists of a closed case (B) on which is mounted the hopper (A) filled with powdered carbide. A sort of stop-cock (R), having a pocket in its circumference, is ro-

tated by the movement of the piston (P), which the fluctuating pressure of the gas causes. At each

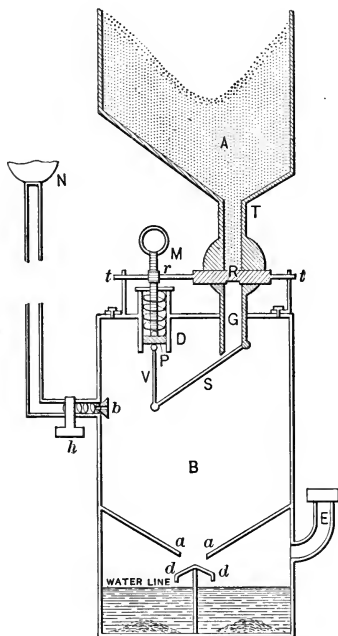

FIG. 32. Marechal Generator.

movement a small quantity of carbide is delivered to the tube (G) and by the movement of the link (S)

is allowed to fall into the water at the base of the machine.

The Thivert Generator (Fig. 33) has a hopper (A) and reservoir (C) carried by the bell of a gasom-

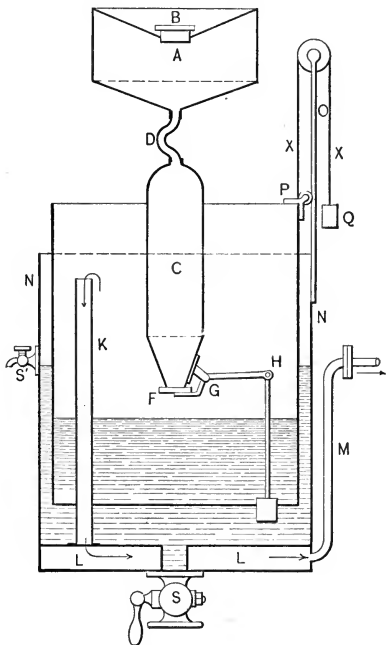

FIG. 33. Thivert Generator.

eter. The mouth of the reservoir is kept closed by means of a disc (F) and weighted lever (H).

Upon the descent of the bell, the weight rests on the bottom, raising the lever and depositing a small amount of the pulverized carbide in the water. As soon as the bell rises, the cover (F) is closed by the weight. Deposited lime is drawn off through the large cock S.

The Bouneau Generator (Fig. 34) is on the same plan, except that the weight is attached di-

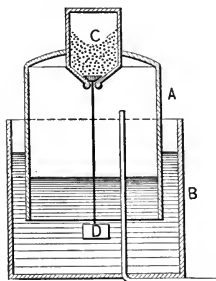

FIG. 34. Bouneau Generator.

rectly to a conical plug which closes the mouth of the carbide receiver. When the bell sinks the plug is lifted, letting carbide fall into the water.

Leroy & Janson have placed the hopper and valve within the gasometer in order to avoid the varying weight on the bell which results from carrying the carbide on that member of the apparatus (Fig. 35). As the bell descends, a rod (L) is pressed, opening the valve (M), which allows carbide to issue. The gas passes by tube (D) to a drier (E) filled partly with pumice-stone and having a layer of calcium carbide, in lumps, in the upper part.

The Lequeux Generator is made in several ways. A simple form for industrial use is shown in Fig. 36. One or more inclined tubes communicating

through a water-seal with a gasometer are divided by a central partition extending from the top downward to a point well below the level of the water contained in each. Carbide is dropped by hand through an opening on the lower side of the parti-

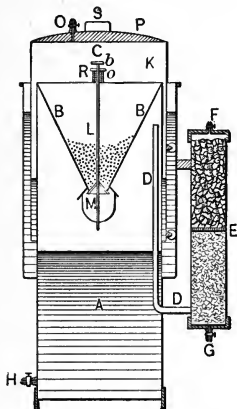

FIG. 35. Leroy & Janson Generator.

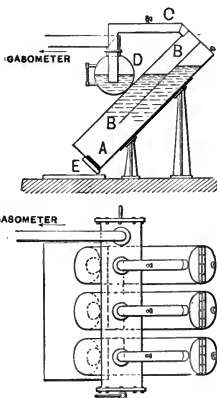

FIG. 36. Lequeux Generator.

tion at the top of the tube. It falls to the bottom, and the gas which is disengaged, rising vertically, enters the part above the partition B, from which it issues by tube C.

Waste lime is removed through the opening E.

Another form is shown in Fig. 37, in which the chute K projects from the side of the generator A. A cover, closed by a water-seal, closes the generator,

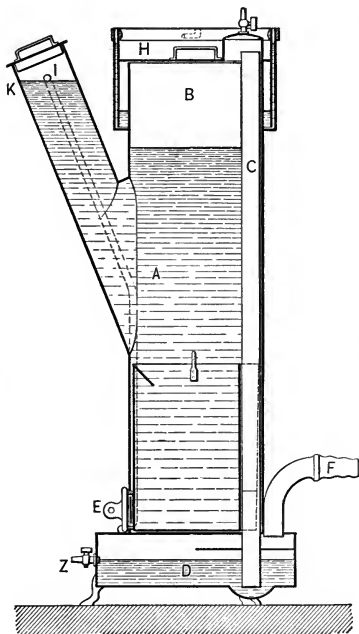

FIG. 37. Lequeux Generator.

which contains, at the bottom, a bucket for removing the lime bodily. Carbide in lumps is dropped down the chute *K* into the bucket. Gas accumulates in *B* while the water is displaced into the chute. *C* is the delivery-pipe, dipping below the surface of

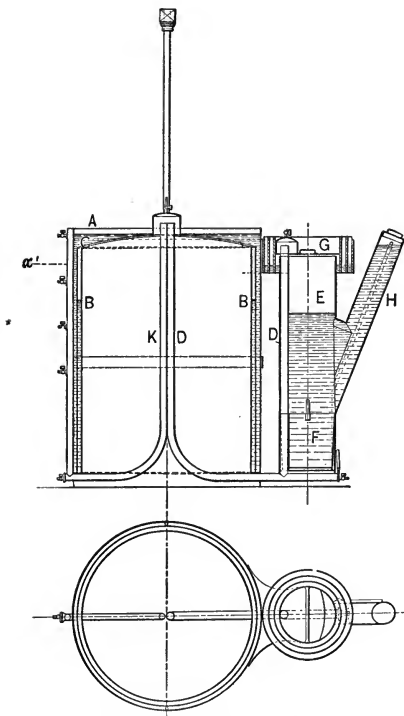

FIG. 38. Lequeux Generator.

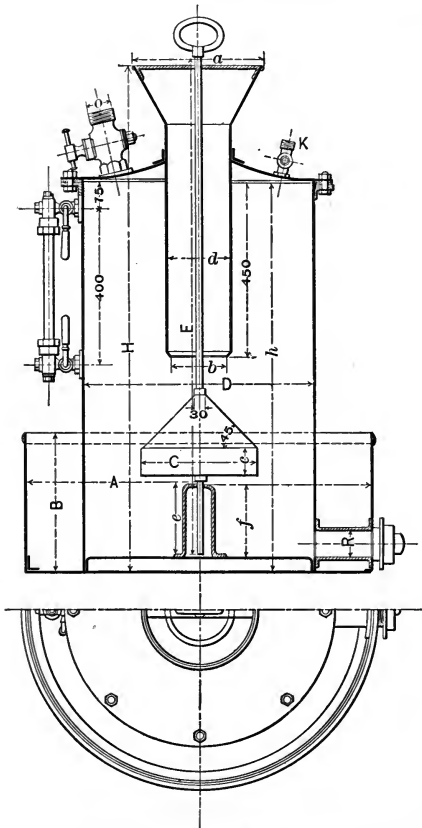

FIG. 39. Société le Gaz Acetylene.

water in a combined seal and washer contained in the base of the generator. The exit-pipe F may be joined to the burners by a rubber tube. This generator, which is one of the best, is shown in combination with a gasometer in Fig. 38. In this arrangement the water-seal (G) is multiple.

La Société le Gaz Acetylene has built a larger and more important generator, shown in Fig. 39, to be used in conjunction with a gasometer. The drawing is self-explanatory. A central tube (E) answers as a chute, below which there is placed a conical deflector (C). The generator is filled to the line D with water. The vessel B, in which the generator rests, is filled with water. The lime is drawn off through R.

The Patin Generator (Fig. 40) differs from the Lequeux only in having its chute

filled with oil, which floats on the water and delays the disengagement of gas from the carbide dropped into it. The plan is of doubtful advantage, as the carbide is constantly carrying oil into the generator, where it is broken up and changed into a disagreeable scum, which is difficult to remove and dirty to handle. This generator is

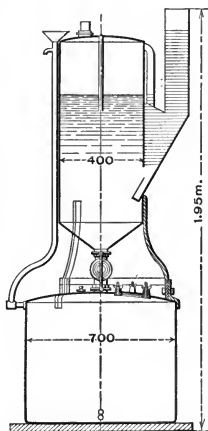

FIG. 40. Patin Generator.

conical at its bottom, where it communicates, by means of a large cock, with a lower vessel filled with water, into which the larger part of the lime

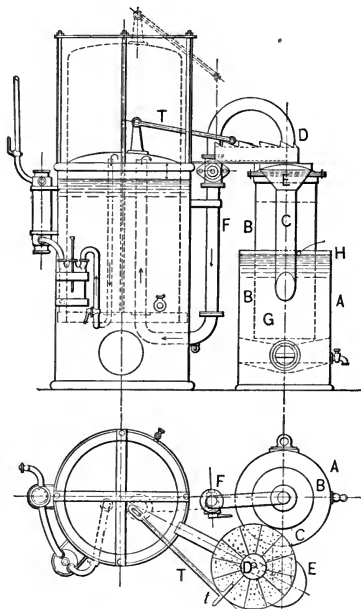

FIG. 41. Seguin and de Perrodil Generator.

drops. When sufficient deposit has accumulated, the cock is closed and the lime removed from the settling-tank.

The Seguin and de Perrodil Generator consists (Fig. 42) of a pair of concentric cylindrical vessels (A and B) filled with water. A chute (C) provided with a funnel (E) permits the introduction of the carbide, which falls into the basket G. The car-

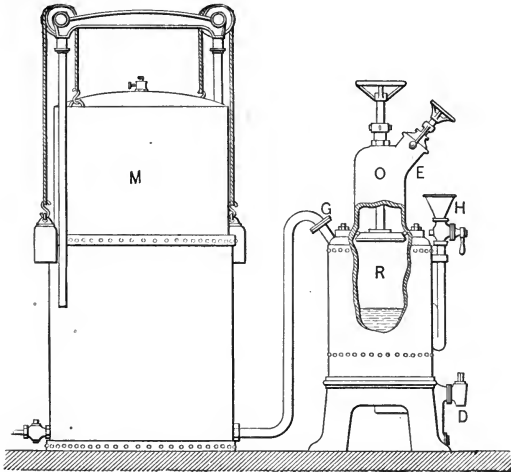

FIG. 42. Bertrand-Taillet Generator.

bide is placed in a distributor (D) turning on an axis and provided with a ratchet-and-pawl mechanism operated by the fall of the gasometer bell. Each time the bell descends, the lever T engages with a tooth of the ratchet D, whereby the wheel is rotated until one of its compartments is brought over the

chute and the contents dropped into the generator. This is a truly continuous machine in every sense. It suffices to keep the distributor pockets filled with

carbide, and to occasionally remove the deposit of lime, to keep it in operation indefinitely.

The Bertrand-Taillet Generator is made in two forms. One requires a separate gasometer of considerable size, as shown in Fig. 42.

A vessel (R) is surmounted by a dome (O) having a tubulure (E) for the introduction of carbide and a screw-operated valve closing its mouth. The carbide is emptied wholly or in part into the water by manœuvring the valve-wheel.

The other form is shown in Fig. 43. It consists of a gasometer having in its

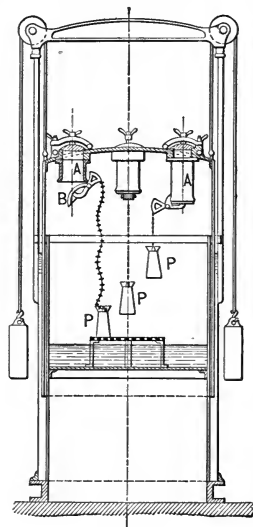

FIG. 43.
Bertrand-Taillet Generator.

bell a number of pockets closed on the outside by tight covers, and by hinged bottoms within the bell. The bottoms are held shut by weights hanging from chains of various lengths, so that the contents of the pockets are deposited in the water successively by the repeated descents of the bell.

ACETYLENE LAMPS.

MANY forms of portable acetylene lamps have been designed, but none, thus far, has been very successful. While the light is in every way desirable, there is some fear of the lamp itself existing in most minds, and even if this is overcome it must be admitted that the best acetylene lamps are troublesome to manage. They require a greater degree of intelligence for their successful handling than do the ordinary oil-lamps, and, in consequence, it is scarcely advisable to trust servants to keep them in operative condition. In addition to these drawbacks to their use, there is the unavoidable odor from the spent carbide, which diffuses itself throughout the room in which the lamp is recharged. In spite of these objections, there are lamps on the market which are most attractive in appearance and for which the manufacturers claim immunity from danger or odor.

In a well-made acetylene lamp the danger from fire or explosion should be very slight, for the entire amount of carbide used for one charge does not usually weigh more than a few ounces. This, if the gas from it was all generated at once, could produce not more than three or four cubic feet; and, as the rate of generation is at a maximum rarely more

than enough to supply one burner, the chance for dangerous leakage is small.

Again, in case of explosion of the gas in the lamp, the shock would scatter the carbide and water harmlessly about, whereas the explosion of an oil-lamp is generally followed by a shower of burning oil.

Lamp of Decretet and Lejeune (Fig. 44).—The carbide is placed in a closed generator (G) in a perforated basket (S). The generator is placed in the body of the lamp, which is filled with water. The water, which serves both for cooling and for generating the gas from the carbide, enters the generator by the tube D, rises to the top of the carbide and drips thereon. As pressure accumulates, the water-supply is arrested and the valve at the top of tube D closes by its own weight. *Re* is a safety-valve. Two funnel-shaped plates (*ch*) are supported above the carbide-holder, which receive the moisture carried off by the gas, and from which it drips back upon the carbide.

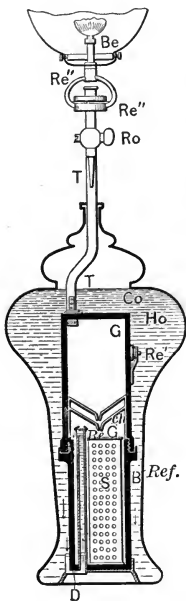

FIG. 44. Decretet and Lejeune Lamp.

by the gas, and from which it drips back upon the carbide.

Lamp of Gossart and Chevallier (Fig. 45).—

This is one of the simplest and best lamps yet designed. The water which is contained in the upper chamber falls drop by drop through the bent capillary tubes upon a mass of carbide placed in the bottom of the lamp. The amount of water is so small that the lime is reduced in the form of a dry powder. About five ounces of carbide forms the charge. In case of increased pressure the flow of water is arrested, and in the event of an abnormal increase the gas would pass out and escape by way of the capillary tubes. It is said that, in full operation, the temperature of the carbide never rises above 125° F., and that the water-supply is so sensitive that, as the flame is turned down, the drops fall less and less frequently until they stop, when the flame is turned out. It is also claimed that the production of gas stops at the same moment. There are no valves, cocks, or other complications. Nothing more simple could be desired.

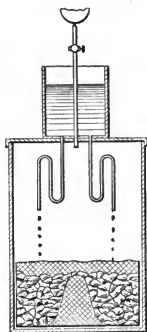

FIG. 45. Gossart and Chevallier Lamp.

The Trouvé Lamp (Fig. 46) consists of an outer vase within which is a small stationary bell, and in that is hung a basket of carbide, which may be raised or lowered by a handle seen on the right of the lamp. As gas is produced, the water is driven out of the inner bell and rises in the outer vase. The basket

of carbide must be occasionally lowered a little deeper into the water. A layer of oil on the water within the bell, on the principle of d'Arsonval's

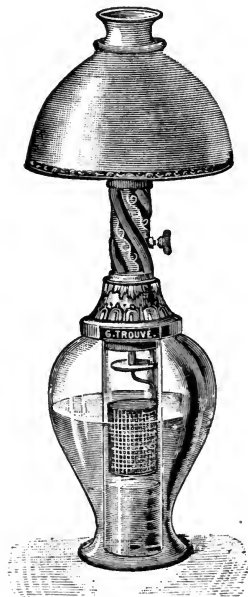

FIG. 46. Trouvé Lamp.

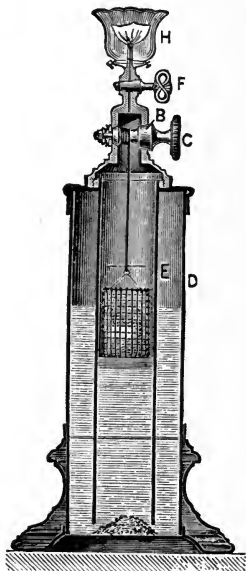

FIG. 47. Türr Lamp.

generator, would certainly improve the steadiness of action of this lamp.

In the **Türr** lamp this has been done (Fig. 47).

The lamp is somewhat larger than the **Trouvé**, and the basket of carbide is suspended by a cord, but otherwise the arrangement is the same.

The lamp devised by Captain **Nou** is in reality a small gasometer and generator (Fig. 48).

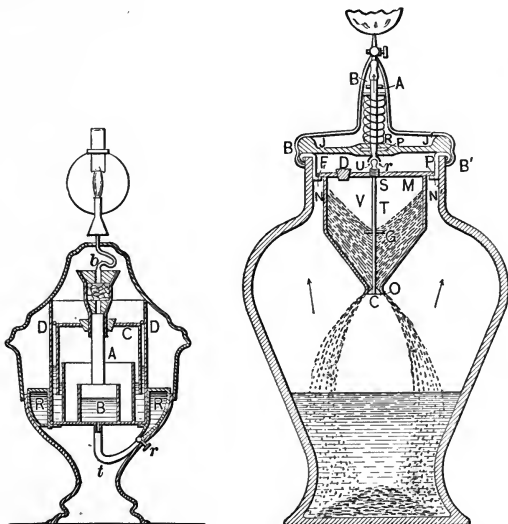

FIG. 48. Nou Lamp.

FIG. 49. Claude and Hess Lamp.

It is said to be very steady in action, but large and unwieldy. Within the outer case is a small gasometer (D) with annular water-seal and the usual bell

(C). As the bell rises and falls a moulded stick of carbide (A) dips into and is withdrawn from the cup of water (B). R is a reservoir, from which B draws its supply.

Lamp of Claude and Hess.—This lamp (Fig. 49) has given excellent results, and were it not for the doubtful keeping qualities of pulverized carbide, as well as the uncertainty of getting it of good quality in the first place, would be the best lamp yet devised.

Its construction is simple. An outer vase contains water in its lower portion, while within its neck is suspended a funnel for holding the pulverized carbide.

A conical plug (C) closes the opening of the funnel. From it a rod passes through the cover of the funnel and is attached to the centre of a thick rubber diaphragm (J, J), which forms the air-tight cover of the lamp. Above the diaphragm a spring (R) presses down upon it.

When the diaphragm sinks, the plug C is pushed down, allowing carbide to fall into the water, and, as soon as gas is generated, the ensuing pressure pushes up the diaphragm and stops the hole through which the carbide issues. The gas reaches the burner through the central tube around which the spring is coiled.

A continuous slight working up and down of the diaphragm takes place as the lamp burns, which dusts the carbide slowly and regularly into the water.

The Buffington Acetylene Lamp consists of a generator and burner arranged in the form of a student-lamp. The upper half of the generator contains a water-reservoir, which is provided at its bottom with a needle-valve.

The carbide, enclosed in a cartridge, is introduced into the lower part of the generator by removing the bottom. A water-seal, contained in the removable part, prevents a dangerous rise of pressure.

The lamp is started, stopped and regulated by means of a small lever on top of the generator, which controls the water-supply.

The lamp burns without odor, and the light is very satisfactory.

The Electro, a compact and light acetylene bicycle lamp, is shown by Fig. 50.

The spherical reservoir is filled with water, which, by means of a needle-valve, is allowed to drop upon the cartridge of carbide contained in the lower cylinder.

The gas is consumed in a small burner located in the focus of a parabolic reflector.

The lamp is charged by unscrewing the milled bottom portion of the generator, inserting a cartridge containing about an ounce of carbide, in grains, and filling the reservoir with water through a hole in the top.

It is intended that the gas shall be generated as used, no gasometer or other compensating device being used.

A fairly close regulation may be obtained by means of the needle-valve.

The quantity of carbide is so small that its temperature is not seriously raised by the disengagement of acetylene. The lamp is designed to burn for three hours at each charging.

It seems only fair to state that acetylene lamps are regarded with suspicion by many insurance com-

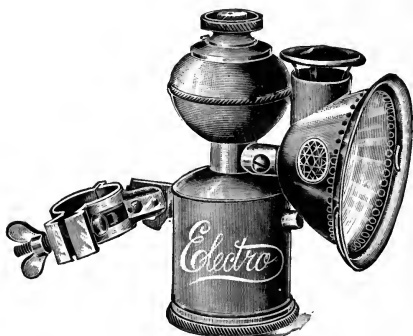

FIG. 50.

panies, and that some refuse risks on property in which they are operated.

The intending purchaser of any acetylene apparatus should therefore assure his position by obtaining the consent of the company which writes his insurance to the use of the generator or lamp which he expects to install.

ACETYLENE BURNERS.

THE ordinary house gas-burners, consuming from 2 to 10 feet of gas per hour, will not serve for lighting by means of acetylene. While an ordinary 5-foot burner with a good quality of illuminating gas is rated at 16-candle power, the consumption of a half-foot per hour of acetylene properly burned gives a flame of fully 25 candles.

Acetylene is a gas so rich in carbon, moreover, that special forms of burners are necessary for consuming it without smoke and with a maxim of luminosity.

A half-foot burner of the ordinary type gives a fairly good light with acetylene for a time, but it soon becomes clogged with a deposit of carbon; and, while the flame when burning at a maximum is very satisfactory, it is not so bright as that given by special burners, nor can it be turned down without smoking.

A burner which aims to avoid the deposition of carbon in the gas-outlets is made as shown in the section, Fig 51.

In it the gas-exits are about three-eighths of an inch apart and are inclined towards each other at an angle of 90° . The exits themselves are very small, but a

counter-bore enlarges their outer orifices to a diameter of about a thirty-second of an inch.

The issuing jets of gas impinge on each other, producing a flat flame. It is expected that the rush of gas through the air shall carry with it sufficient oxygen for perfect combustion, and that the enlarged outer orifices shall not be clogged by a slight deposit of carbon.

This burner, in spite of these precautions, deposits carbon on that part which is between the jets, and which is comparatively cool.

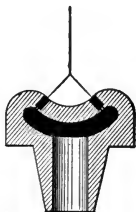

FIG. 51.



FIG. 52.

The carbon deposit grows in the course of an hour to such size as to deflect the jets, when the flame begins to smoke.

A better form has two slender tubes which, issuing from a common base, curve toward each other (Fig. 52).

The flame is of the same character as that of the last-mentioned burner, but the deposit of carbon is

prevented so long as the burner is not turned down low.

In other burners these jets have variously shaped apertures (Fig. 53), but none causes a sufficient mixture of air with the flame to give the best results.

Various expedients have been suggested for dilut-

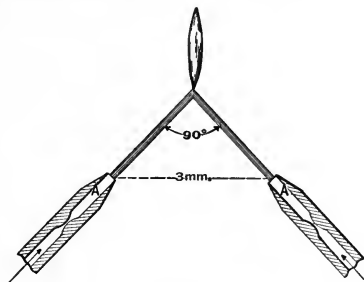

FIG. 53.

ing the gas. Among early experimenters the bold attempt was made to mix air with the acetylene in the gas-holder, but this having resulted in several accidents through the ignition of the explosive mixture so produced, carbonic acid and, afterward, nitrogen were tried.

The last gas gave the best results, but was troublesome to prepare and increased the expense of operation.

Finally, however, by adopting the principle of the Bunsen burner (Fig. 54), it was found possible to mix any desired proportion of air with the gas as it

issued from the burner. A further development consisted in making each burner double, with jets inclined toward each other, as in the types last mentioned. This burner, which has been patented in this country, is nearly all that can be desired.

Its flame is intensely bright, it can be turned down without smoking, and deposits no carbon unless left turned down very low. In that case a little ring of hard carbon is likely to form at the exits of the jets, but the burner, even then, does not smoke.

The burners are of the form shown in Fig. 55, being of brass, with so-called lava tips. The tips are veritable little Bunsen burners. A central small aperture leads from the base of the tip to a point opposite the constricted neck of the burner, beyond which point the bore is considerably enlarged. From the constriction, four inclined apertures enter the enlarged bore.

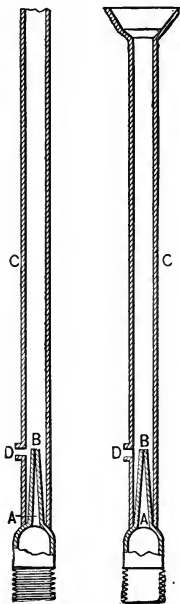

FIG. 54.

From this construction it follows that the gas, in issuing from the small jet into the larger bore, causes a slight reduction of pressure therein, which induces a flow of air through the side openings.

The incoming air and gas mingle and burn on leaving the tip. The two jets, meeting each other, flatten out into a fish-tail shape, and in so doing excite a still further flow of air to their surfaces.

When the burner is turned fully on, the luminous flame does not extend quite to the tips of the jets. The mixture of gas and air next to the jets is not at a suitable temperature for depositing carbon.

The burner illustrated in Fig. 55 is the invention

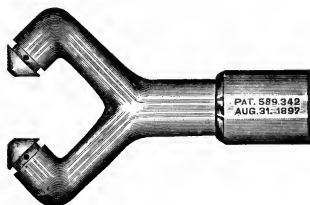

FIG. 55.

of Mr. Edward J. Dolan, of Philadelphia, who has devoted much time to experimental work on the combustion of acetylene. Other forms of burners invented by Mr. Dolan are illustrated in the following figures:

Fig. 56 shows a burner which has a lava tip (A) provided with a deep, vertical slot (B). A small passage (C) delivers the acetylene to the slot (B) at an acute angle. The gas impinges on the wall of the slot (B), and, in its passage to the top of the burner, draws along with it a current of air. The mixture of air and acetylene burns in a fish-tail flame

without smoke. The gas-orifice is below the point at which carbon can be deposited.

Fig. 57 shows the same burner having two gas-outlets. It is probably a better form.

Fig. 58 is a burner for consuming a larger quantity of acetylene than is generally burnt in one unit. The tip (G) of this burner has two small Bunsen type of jets inclined toward each other, and, in addi-

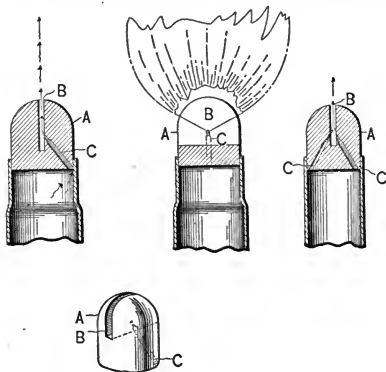

FIG. 56.

FIG. 57.

tion thereto, is provided with a vertical gas-outlet situated between the other two.

A gas-heater by the same inventor is shown in Fig. 59.

The entire structure consists, substantially, of two annular castings, of which 1 represents the base and outer portion, and 2 represents the inner ring, form-

ing the completed burner. The inner ring screws into the outer by a suitable thread, as at 6. There is an annular gas-chamber (7), formed by suitable circular slots cut in these two rings, which, when joined

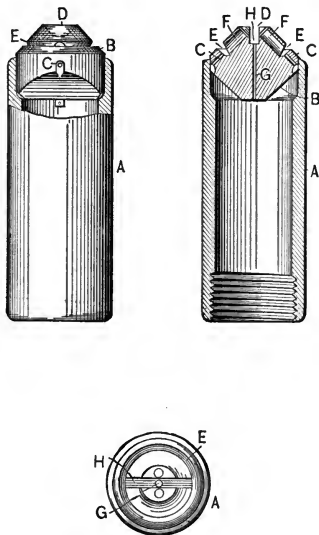

FIG. 58.

together, make the chamber indicated. This communicates with the gas-supply pipe (3). The upper ring (2) is cast with a series of sectors (8) projecting

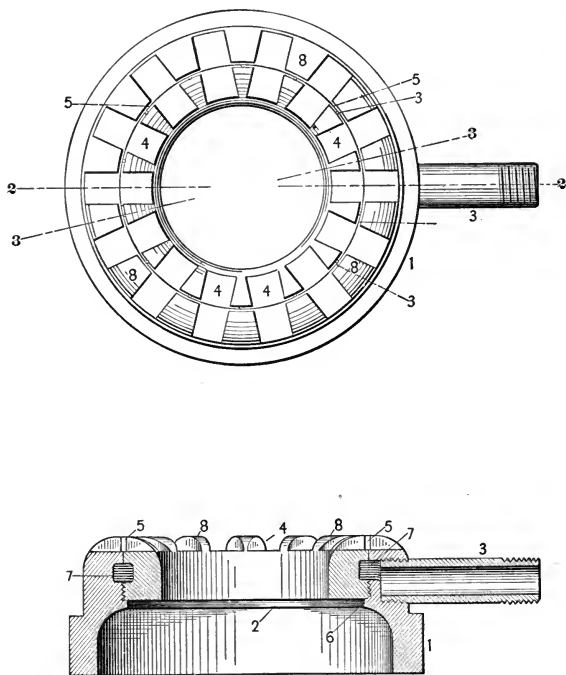

FIG. 59.

above the horizontal surface of the ring. They have between them openings (4) extending down to such horizontal surface, and also transverse slots (5) communicating with the openings or channels (4). The small gas-openings (3) are arranged in the centre of the transverse slots (5), as will be readily seen from the plan, the inner ring (1) being suitably cut for that purpose. Of course these gas-openings can be arranged in either ring, or may be formed between the joined rings. By simply unscrewing the inner ring, the apparatus is readily cleaned.

In operation, air is mingled with the gas in the slots (5), and combustion occurs only above the upper surface of the joined rings, the gas burning there when mingled with a suitable quantity of air to form the desired flame. The material ordinarily employed for the structure is iron, but other materials may also be used.

The ordinary Bunsen burner, made considerably smaller than usual and provided with an adjustable air-inlet, gives a long, slender, luminous flame, which is said to be very effective for groups of lights.

Unless the outer orifice of the Bunsen burner is smaller than a quarter of an inch, the flame snaps back and burns in the tube. With a larger supply of air, the true, colorless Bunsen flame is produced from acetylene, and is much hotter than that of ordinary gas. It may be used with advantage in the laboratory for many operations which usually require the blow-pipe.

Almost every conceivable form of burner and

tip has been tried, but it seems unnecessary to describe or figure those which have been found unsatisfactory.

It may be predicted with a reasonable degree of certainty, from what we already know of the properties and composition of acetylene, that it will be necessary, in all successful burners, to use the Bunsen principle for mingling air with the gas as it leaves the jet.

Many forms of burners have already been designed on this plan, which allows considerable latitude in its application.

AUTHOR'S EXPERIMENTS.

THE author's experiments with generators began with a small apparatus constructed on the principle of the hydrogen lighter (Fig. 29), in which a reservoir was partly filled with water having a layer of oil about six inches deep floating thereon. A bell descended into the outer vessel. It had an opening through which a perforated can, filled with calcium carbide, could be introduced and adjusted in height by means of a rod passing through a stuffing-box. This affair worked remarkably well on a small scale. The oil, into which the carbide was lifted by the rising bell, effectually displaced the water and stopped the evolution of gas. When one or two burners were in operation, the bell descended until the carbide was partly immersed in the water, the degree of immersion being such as would supply the gas at the rate used.

In this respect the device was very satisfactory, and was quite self-regulating. The carbide being introduced in a finely perforated can, the amount of lime which escaped into the water was small. The disadvantages were such as to preclude the use of the apparatus for anything more than experimental work.

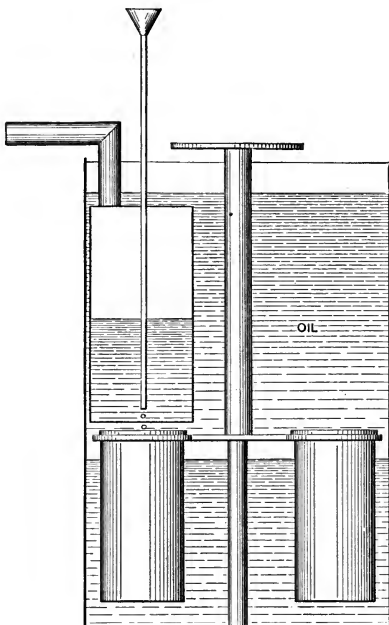

FIG. 60.

In the first place, the introduction of fresh carbide involved the loss of the remnant of gas contained in the bell. Secondly, the petroleum-oil used absorbed gas readily, and as easily gave it off, causing a strong odor of acetylene to issue from the machine. This

could be overcome, however, by having the oil within the bell only and never permitting the edge of the bell to rise to a height sufficient to allow of its escape.

Thirdly, the use of strong brine was necessary in winter to prevent the freezing-up of the machine, which was kept out of doors.

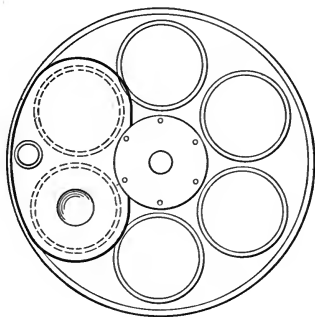

FIG. 61.

The use of oil in this way must have occurred to many, and the discovery, only recently, that the identical machine had been devised a year earlier in France by d'Arsonval was not surprising.

The next expedient tried was the immersion of the carbide in oil at the bottom of a reservoir, and the addition of the water thereto in a small stream, which, sinking through the oil, attacked the carbide. The carbide was contained in a series of cans, any

one of which could be brought under a stationary bell in turn, and there receive the water which entered the bell through a small pipe, and which had its flow regulated by the rise and fall of a gasometer connected to the generator (Fig. 60).

Uneven production of gas, bad odor, and general mussiness caused this plan to fail in practical application.

The plan is unusually attractive, and, with improvements, may yet offer a simple solution of the problem of the generation of acetylene.

Experiments showed that it was not only desirable, but necessary, to have any machine for generating acetylene in sufficient quantity for domestic lighting removed and quite isolated from inhabited buildings. Aside from the possible element of danger, there was the disagreeable odor, which is quite inseparable from the use of calcium carbide. Very little smell is noticed in charging a properly constructed machine, but the removal of the spent lime, always charged with a strong odor of gas, is, to say the least, unpleasant unless conducted in the open air. The gaseous odor has a peculiarly lingering and diffusive character. A little of it goes a long way, and to some it is intensely disagreeable. The isolation of the generator means that it must be placed in a separate building sufficiently protected from the weather, or so heated, as to prevent the freezing-up of the machine, or it must be placed in a vault underground.

The last-mentioned proceeding seems the more

desirable, since all danger of freezing is removed when the surface of the water in the generator or gas-holder is three feet or so under the surface of the ground; and in addition to this advantage is that of avoiding the erection of a separate and probably unsightly or undesirable building.

The only disadvantage arising from this disposition of the generator is the difficulty of removing the lime resulting from the action of the water on the calcium carbide.

The so-called "chute" type of machine lends itself particularly to underground use.

The first machine of this kind experimented with consisted of a sheet-iron cylinder three feet in diameter by seven in height. A chute entered the lower portion of the cylinder, which was buried in the ground.

From the bottom of the cylinder a two-inch pipe led with a gentle curve to the surface of the ground, where it was surmounted by a common pump. An inverted bell within the cylinder formed the gas-holder.

It was found necessary to add a deflector within the cylinder, since the evolution of gas was sometimes so rapid that bubbles would be driven to the sides of the cylinder and rise outside the bell.

The carbide was at first dropped down the charging-pipe by hand. As the capacity of the bell was twenty cubic feet, and as it was undesirable to allow it to become entirely empty of gas before refilling, it was customary to add the carbide in charges of

about three pounds, which were simply dropped from a tin-can into the charging-pipe.

A lively evolution of gas immediately followed, lasting about ten minutes, when the carbide was all reduced and the bell full of gas.

After using a hundred pounds of carbide, the precipitated lime was pumped out into a couple of galvanized-iron cans, from which, after the lime had settled to the bottom, the water was decanted back into the generator.

An agitator was incorporated into the machine. The central part of its lower extremity was fitted to the bottom of the pump suction-pipe, thereby preventing lime from settling and becoming impacted therein. The handle of the agitator passed up through the bell, for which it formed a guide. In use, the agitator was gently revolved a few times and then lifted up a few inches. The pump was immediately put to work, and no difficulty was found in removing the lime in the form of a thin paste.

Later developments showed the desirability of making the operation of the machine continuous. In order to accomplish this end, an automatic device was added which emptied the contents of a sealed can of carbide into the charging-tube whenever the bell sank to a certain point. Figs. 62, 63.

At first the expedient of soaking the carbide in kerosene was tried, and the charging-pipe, or chute, was, after the manner devised by Hospitallier, partly filled with kerosene, which floated upon the water.

Two objects were attained by this procedure.

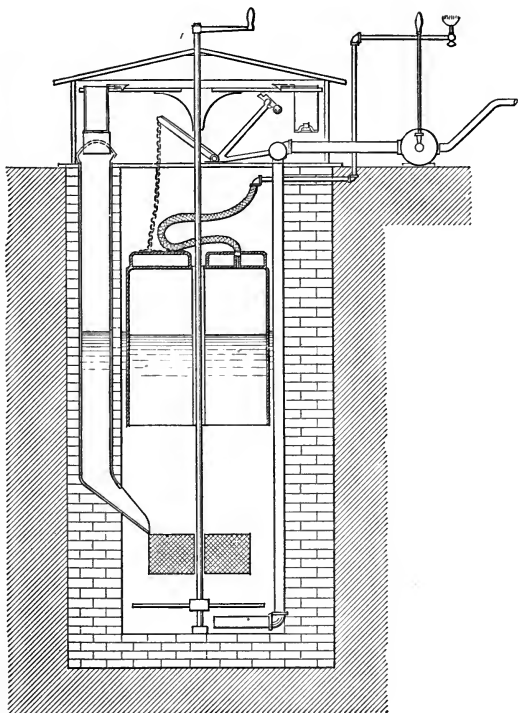

FIG. 62.

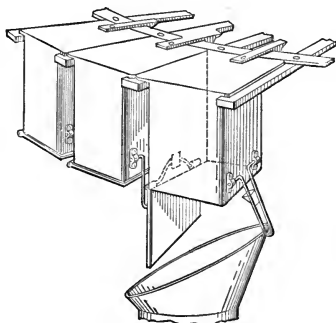
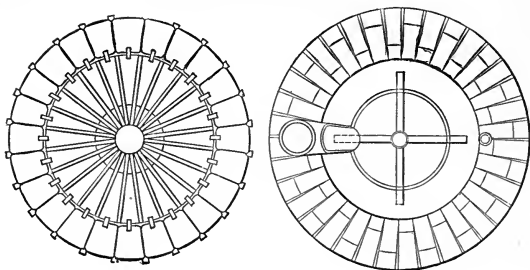

FIG. 63.

The carbide in the original package was protected by the oil from the action of the atmosphere, so that, when a fresh can was opened, the pouring in of a gallon of oil rendered the use of an air-tight cover unnecessary.

The layer of oil in the charging-pipe, by forming a coating on the carbide in its passage down the chute, delayed the action of the water until the generator was entered.

Continued experiment showed that the oil which entered the generator with the carbide was so changed in structure that it formed a thick, unsightly scum on the surface of the water under the bell, which retarded the disengagement of gas and was a most disagreeable feature when it became necessary to clean the machine. This scum finally became so troublesome that the use of oil was reluctantly abandoned.

The cans containing the carbide on the distributor were furnished with rubber washers, on which the cover bore, making an air-tight joint after the fashion of the ordinary glass fruit-jars. It was also found that the descent of the carbide through the chute was so rapid that practically no gas was given off until the generator was reached.

The distributor above mentioned consisted of a horizontal disc turning freely on a rod which passed through its centre. It was pierced near its edge with a row of holes, each of which held, by means of a bayonet-joint, a carbide can four inches in diameter by seven inches deep. The cans were held top down, and the cover of each was held shut against a rubber washer by means of a spring latch.

A ratchet and pawl, operated by the fall of the gasometer bell, brought each can in turn over the charging-pipe, where its latch was tripped, and the

contents dropped down the chute into the generator.

A sufficient number of cans was provided to hold the contents of a one-hundred-pound package of carbide, which, on being opened, was at once distributed among them and sealed by closing the air-tight covers.

Once a week the empty cans were removed from the distributor and replaced by full ones. A glance showed which were empty, since the covers hang down after the latch is tripped.

At the time that this machine was constructed, it was thought to possess some advantages over others, inasmuch as it was non-freezing, had no valves nor cocks, could not accumulate pressure, and was automatic in action.

It was seen, however, after due consideration, that in ignorant hands there was one possibility of accident. If, in pumping out the lime, the level of the water in the gasometer was unduly lowered, it might happen that the bell would reach the bottom of its travel. Further pumping would create a vacuum, tending to draw the flame of any lighted burners back into the piping and eventually to the bell. That this can happen seems doubtful, but it has been said to have occurred under certain conditions. At all events, the lights would go out and air would enter the system. Continued pumping would lower the level of the water below the edge of the bell, allowing air to enter. If, under these circumstances, the generator was refilled with water without having

taken the precaution to draw off the mixture of air and gas from the bell, the conditions would favor an explosion if a flame was brought into proximity with the smallest leak or imperfect joint.

In order to guard against just such conditions, various forms of machine were devised.

Some had the generator and gasometer separate, while others provided for the removal of the lime by lifting-out cans, into which the precipitate was directed.

After many experiments, the original form of machine as last described was finally adopted, and the very simple expedient tried of making a small hole through the wall of the pump suction-pipe at the lowest intended water-level, since it was found that the pump removed the lime perfectly and with less labor than any other method.

The generator finally took the form shown in the last engraving, after passing through the intermediate stage shown in Figs. 62 and 63.

The gas generating and holding portion of the acetylene machine is contained in a cylindrical cistern of iron or brick, of an area determined by the amount of gas required.

The cistern is partly filled with water, the surface of which is below the line of frost.

A gasometer-bell occupies the upper portion of the cistern, which it nearly fills, and rises or sinks in the water as gas enters or is drawn from it.

This bell is provided at its upper part with an airtight, annular flotation-chamber, the use of which

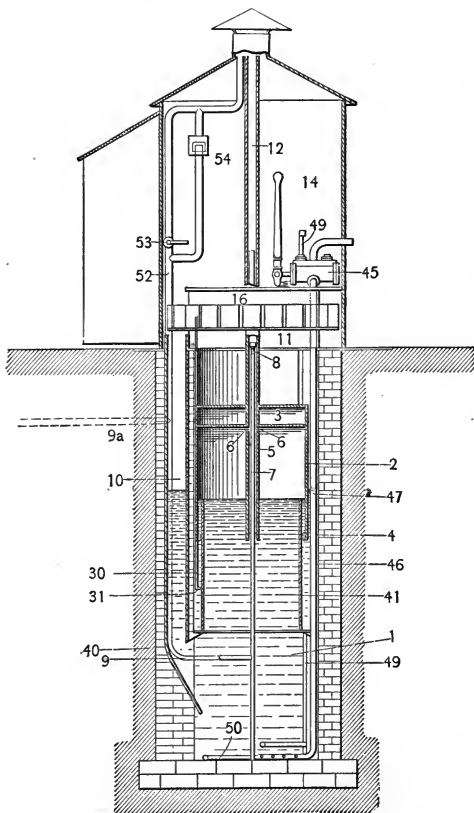

FIG. 64.

will be described later, and has at its lower edge a heavy rim of iron, for the purpose of giving sufficient pressure to the gas contained therein.

The bell contains a central tube, open at the bottom, which projects for some distance above the top of the flotation-chamber and serves as a duct for leading the gas from the bell to a second smaller concentric tube fixed in the cistern.

This second tube has openings above the water-line of the cistern, and is connected with the system of piping and burners where the gas is used. Its upper end telescopes into the tube of the gas-holder, for which it forms a guide.

A "chute," contained in the wall of the cistern, directs the calcium carbide dropped into it to the generating portion of the machine, located at the bottom of the cistern.

The cistern is covered by a drum of iron, into which the gasometer may rise. This drum is closed on top, but is provided with a vent-pipe leading into the ventilator of the small iron building which covers the whole machine.

On a circular track around the circumference of the drum travels a series of small cans.

Each can has a hinged bottom provided with a rubber washer and held shut by a latch. Since the cans, when closed, are air-tight, the carbide within them is entirely protected from the air until the moment when it is needed, at which time the gasometer bell, in its descent, by means of a ratchet-and-pawl mechanism, carries a can of carbide over the chute,

trips the latch and drops the contents into the bottom of the cistern.

The gas evolved by the reaction between the water and the calcium carbide rises through the large quantity of water above it, being directed into the bell by means of the deflector. It reaches the bell cool and thoroughly washed.

As the bell rises and falls, carbide is automatically fed to the generator, canful by canful, so long as any remains.

The removal of the deposit of lime, which is necessary only at long intervals, is effected by means of a pump and a suction-pipe which reaches the bottom of the cistern.

A small hole is bored through the suction-pipe at the normal level of the water in the cistern.

The process of removing the lime consists in first adding water to that in the cistern until the level is raised a couple of feet.

The pump is then operated as long as it removes lime and water.

When the water in the cistern has been reduced by pumping to its normal level, air enters the small hole in the suction-pipe, stopping the action of the pump.

Consequently, the water-line can never by carelessness be brought below the point intended.

The operation of the ratchet, and consequent feeding of carbide, when too much water is contained in the cistern, would be undesirable, causing over-production and waste of gas.

This is prevented by the flotation-chamber contained in the bell, for, since the bell cannot sink below the water-level, it cannot fall far enough to operate the can-moving mechanism unless the water-line is normal.

The gas-delivery pipe has a branch extending into the ventilator of the covering-house, with a cock for allowing the gas contained in the bell to be drawn off, if desired.

A loop of pipe around the cock contains a mercurial seal, which automatically discharges any surplus gas in case its pressure exceeds four inches of water.

The covering-house protects the machine from the weather, and prevents access to the working parts by unauthorized persons. It also provides ample storage-room for a supply of calcium carbide, and a place in which the carbide may be transferred from the original packages to the air-tight cans in which it is supplied to the machine.

A sufficient number of cans is provided, in addition to those in use, to hold the contents of a one-hundred-pound package of carbide.

The carbide cans are held in place on the charging-wheel of the machine by a simple fastening, which permits the empty ones to be easily removed and full ones substituted.

It is necessary to pump out the lime only twice a year when the machine is supplying the ordinary demands for a dwelling-house in which there are from twenty-five to thirty burners.

In suburban places, it answers perfectly to dispose of the lime by pumping the contents of the machine into a hole dug in the ground. The water disappears in a short time by seepage leaving the lime at the bottom of the hole, which is then filled with the earth previously taken out. A hole three feet deep is ample in most soils. In many cases, a smaller one will do as well.

Instead of making the outer case of iron, it may be built up of brick laid in portland cement, or it may be formed of earthen pipes, which may be obtained of any diameter up to three feet.

In giving this machine, which contains about forty cubic feet of water, its initial charge of calcium carbide, it is a noteworthy fact that the first four or five pounds of the substance thrown into the chute fail to cause more than two or three inches rise of the gasometer bell.

In other words, the solubility of the gas in the water is so readily effected that, until a considerable degree of saturation has taken place, very few of the bubbles of gas which are generated at the base of the machine reach the surface of the water.

The action reminds one of the "singing" stage of a kettle which is set to boil, where the bubbles of steam generated at the bottom of the kettle are condensed by the cooler upper portion of the liquid before they reach its surface.

Two inferences may be drawn from these facts: First, that the renewal of the water should be

avoided as much as possible, or that a saline solution which absorbs only five per cent. of its volume of gas should be used.

Second, that a source of danger from explosions exists in this body of gas-charged water.

Suppose a leak had been discovered in the bell of the gasometer. A careless individual might let all the gas escape, and then, in order to easily reach the bell, might draw it out of the water, letting air enter as it was raised. He might then, without removing it from the liquid, attempt to mend the leak with a soldering-copper or a blow-pipe, under the impression that there was no gas in the bell. In reality, as the bell was raised, the pressure on the water would be diminished, so that a certain amount of gas would be set free and would mingle with the air in the bell, forming an explosive mixture.

On the other hand, in the usual routine of gas making and using, the large body of water is a decided safeguard, preventing, as it does, any appreciable rise of temperature of the carbide or gas, and therefore guarding against any decomposition, while at the same time it gives the gas a thorough washing on its way to the bell.

The gas generated from the lumps of carbide leaves them in a continuous stream of small bubbles. There is no violent, sudden or explosive action visible. Although the evolution of acetylene is rapid, the gas is broken up into very small bubble units. From this it follows that, while the surface of the

water, as seen when the bell is removed, is thrown into violent commotion, and is in every part in brisk ebullition, the water itself is not thrown into the air, but rolls over and over as the bubbles leave its surface.

CONCLUSION

AFTER a careful study of the United States patent specifications of the acetylene generators, which will be found at the end of this volume, the author is impressed with the curious fact that they may all be included in the first two classes.

The greater number are of that variety in which the carbide is contained in a closed receptacle, to which water is fed in small quantities.

The remainder are of the type which the French call "briquet hydrogen." They have the carbide suspended in a basket within the gas-holder, with means for alternately immersing and withdrawing it from the water contained therein. With the exception of one machine, which occupies an intermediate position, there is none in which the carbide in small charges is dropped into a large quantity of water. This class of machine, which has been named the "chute generator," offers certain advantages which cannot be obtained with the others.

The French and German experimenters upon acetylene, who have earnestly sought the best means of gas-production, report uniformly in favor of the chute generator. When properly made and installed, however, this machine is rather expensive.

This is especially so when means are provided for the periodical removal of the deposited lime, and when the generator is made of sufficient capacity to supply gas continuously over a prolonged space of time.

The American public, as a whole, is unusually well-informed concerning the development and progress of recent inventions. It wishes, moreover, to encourage the introduction of such novelties as contribute to its comfort, save its time, lessen its labor, improve its health, or in any way render more easy the pursuit of happiness.

That the American is by nature an inventor is a proof that he meets with support from his fellows. Coupled, however, with the desire to look with favor upon all that which is new and meritorious, there is constantly in the demand of the public a cry for cheapness.

The advent of the acetylene light has satisfied this requirement with an illuminant of unprecedented excellence. That having been accomplished, there seems to be no good reason why further demands for a cheap generator, unless entirely consistent with safety and durability, should meet with encouragement. One of the most attractive features of acetylene production is the ease with which the gas may be generated in quantity sufficient for a demonstration of its properties. It seems unfortunate, however, that the performance of the crudest and most flimsy generator should be, to the uninitiated, so satisfactory, for while, as has been said, the public

is in sympathy with new devices, it lacks the technical knowledge to differentiate between the good and poor machine upon their respective showings.

The inventor is little to blame who, stimulated by competition and the inability to sell any but the cheapest generator, reduces the size and cost of his machine to the lowest possible limits.

Acetylene is, until "something happens," a substance so easily managed, so capable of control and apparently so unlikely to manifest its latent affinities, that the vigilance of the experimenter becomes relaxed. He attempts things in his increasing confidence which he would consider dangerous had his experience been more varied.

The very simplicity of acetylene production, which renders the construction of cheap and unreliable generators possible, has acted as a check to the further development of the art.

The public, in making cheapness the most important feature of a machine, is, perhaps, also blameless, in default of more general technical information.

As acetylene becomes more generally used and the public becomes better informed concerning the properties of the gas and of the carbide, it will be placed in a position to decide for itself how much risk it is warranted in taking.

In the meantime, the responsibility should be made to rest with the fire insurance companies. It does, in fact, rest there now, for it is true that safe and efficient generators are not lacking. It is also true that the insurance companies, through the

boards of fire underwriters, employ experts to pass judgment upon the machines submitted to them.

Unfortunately, the experts in some cases have not paid that heed to the increasing use of acetylene generators which its importance would seem to demand. Any laxity in this matter will, however, be corrected when the companies who write insurance upon property containing machines of doubtful safety learn by costly experience the error of their ways.

As a guide to the experimenter who is seeking to devise an acetylene generator, the requirements of the New York Board of Fire Underwriters are here reprinted.

These requirements, in the main well devised to prevent the use of dangerous machines, are certainly very exacting, but in the present state of the art a conservative attitude is the only one which is quite safe.

As more experience is gained, the requirements will, no doubt, be changed from time to time, in order to keep abreast of the developments.

As a temporary measure, at least, they seem all that can be desired.

ADDENDA

SINCE the foregoing was written, the author has found an increasing demand for a small portable generator, and in his efforts to construct one which should be entirely safe, he has tried many forms. The generator shown in Figs. 65 and 66 was, after many experiments, finally developed.

It consists of a gasometer and generator placed side by side. There is nothing peculiar about the gasometer, except that at its side it carries a long water-seal consisting of two concentric tubes having a water-space between them. The inner tube carries the gas into the gasometer bell, while the outer one communicates at its lower extremity with the water contained in the gasometer case. From the generator comes a tube, which telescopes in between the two others forming the seal.

The generator consists of a cylindrical can of galvanized iron, into the top of which fits a bell-shaped gas-collector. This is provided with an eduction pipe for the gas, and is pierced by a short chute into which the carbide is dropped from a charging wheel as in the larger machine.

Upon the gasometer is a square box built round the pipes forming the water-seal, for which it forms

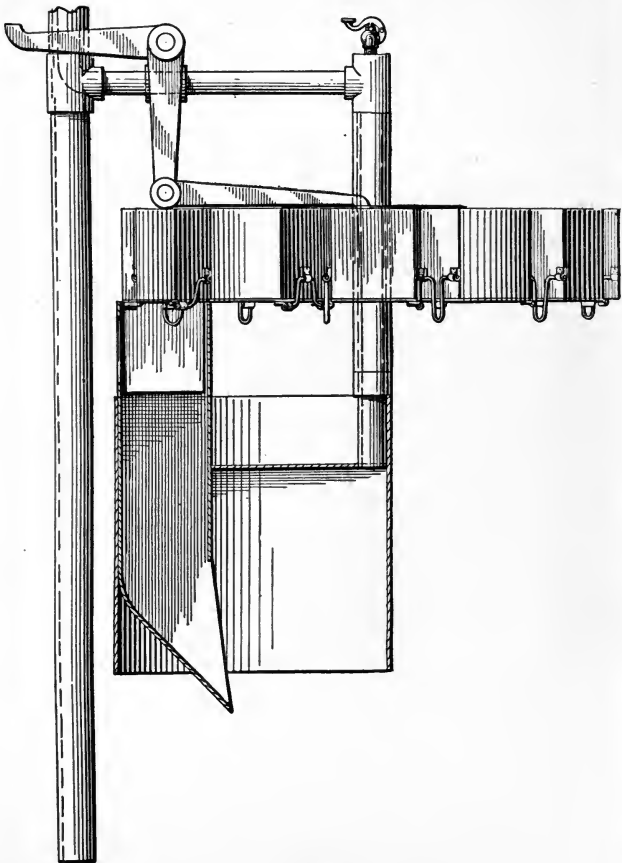

FIG. 65.

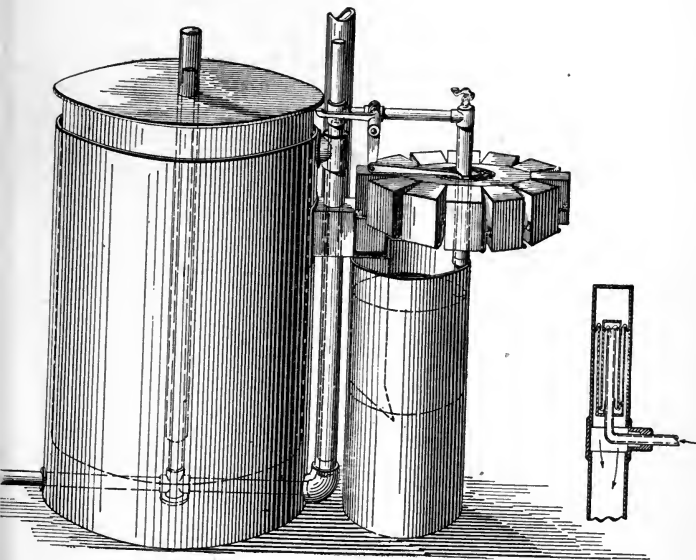

FIG. 66.

a support. A ventilating pipe from this box leads into the outer air.

The box and chute touch each other when the generator is in use.

A large hole in the side of the box coincides with a similar hole in the side of the chute, so that any gas coming up the latter will be drawn into the ventilating pipe and carried away. The front of the chute is cut away at the top in order to allow the covers of the carbide cans to clear the walls when the charging wheel is rotated, but the opening is closed by the can-covers as each in turn swings to a vertical position after the latch is tripped, so that during the descent of the carbide into the generator the chute is made practically continuous with the ventilating pipe.

In order to put the machine into operation, the generator can is filled with water and after being placed in position, the collector is lowered into place. The long telescopic seal on the side of the gasometer permits sufficient vertical motion, and the small spring-closed air-vent on top of the gas-pipe when pressed by the finger, allows the air to escape from the system as the collector is lowered.

The carbide is fed from the cans on the charging-wheel by the motion of the gasometer bell.

The reduced lime collects in the generator can, from which it is periodically removed, after withdrawing the collector and its attached parts, by carrying away the can bodily. A water-seal between

the generator and gasometer prevents the return of gas which has once entered the bell.

Any gas which is given off from the carbide in its descent through the chute is drawn into the ventilating pipe and carried out of doors. The chute is so short, however, that almost no gas is generated in it, but as a further preventive, a layer of oil may be used, as in Hospitalier's generator.

There is no objection to the use of oil in this generator, since it does not enter the gasometer, and that which is carried into the generator can be emptied out bodily with the lime.

REQUIREMENTS

OF

THE NEW YORK BOARD OF FIRE UNDERWRITERS

FOR THE

Installation of Acetylene Gas Generators

AND FOR THE

STORAGE OF A LIMITED SUPPLY OF CALCIUM CARBIDE.

1. Plans and specifications in detail of Acetylene Gas Generators must be submitted to this Board for approval, and a copy of the same placed on file in this office. If the plans are approved, a special examination of the generating apparatus will be made (at the expense of the applicant), and if it is found to be in compliance with the following requirements, a certificate of approval will be granted :

2. The generating apparatus must be located in an outside, fireproof and well-ventilated building, where it will not be an exposure to any adjoining property. The buildings in which generators having a capacity of more than twenty-five pounds and not exceeding one hundred pounds of calcium carbide are placed, shall not be located within ten feet of any other building ; and the buildings in which generators having a larger capacity than one hundred pounds and not exceeding five hundred pounds of calcium carbide are placed, shall be restricted to a distance of not less than twenty-five feet from any other building, and these shall have the constant supervision of a competent person.

3. The dimensions of the generator building must be confined to the requirements of the apparatus, and the limited

supply (hereinafter mentioned) of surplus calcium carbide, which must be packed in water-tight metal cans, and said buildings shall be located as follows :

For generators with capacity of more than twenty-five pounds and not exceeding one hundred pounds of calcium carbide, and, in addition, one hundred pounds of surplus carbide—not less than ten feet from other buildings.

For generators with capacity of over one hundred pounds, and not exceeding five hundred pounds of calcium carbide, and, in addition, not over five hundred pounds of surplus carbide—not less than twenty-five feet from other buildings.

The storage of calcium carbide on premises, other than in generator building, is absolutely prohibited.

4. In constructing the building, dryness and ventilation must be secured. To meet these requirements, the floor must be raised above the grade on which the building is located, and suitable drainage provided. Ventilation is to be obtained by air passing from the outside of building through holes at the floor and through a pipe at least six inches in diameter, at the roof. The said pipe must extend at least four feet above the roof, and must be topped with a guard-cap, and if there be any building within ten feet of said pipe, then the ventilating pipe must be carried four feet above the roof of the higher building.

5. The maximum pressure of gas stored in a gas-holder shall be limited to eight inches of water, and both the generator and gas-holder shall have water safety-seals (not to exceed the same limit) in connection with escape pipes of not less than one and one-half inches in diameter. The escape pipes must be connected above the roof with the ventilating pipe of the building in which the generator is located.

6. A generator in which the gas is both generated and stored (the maximum pressure of which shall not exceed five pounds per square inch) and having no water-seal, shall be tested to withstand a hydraulic pressure of twenty pounds per square inch. The generator shall have a pressure-gauge, also

a safety-valve (not less than one and one-half inches in diameter) adjusted to release the pressure of gas should it rise above the prescribed maximum limit. An escape pipe must be affixed to the safety-valve, and connected above the roof to the ventilating pipe of the building in which the generator is located. A certificate attesting the hydraulic test is to be placed on file in this office.

7. The pressure of the gas shall be regulated at the generator or gas-holder, so that it will not exceed four inches of water on the pipes inside of the building to be lighted. A mercurial seal, set to that pressure, must be attached to the supply-pipe at the generating building. A stop-valve shall be placed on the supply-pipe at the place where it enters the inside of the building to be lighted.

8. All generators and gas-holders shall be connected by at least one and one-half inch escape pipes and stop valves with the ventilating pipe at the roof of the building, through which the gas can be conveyed and discharged with safety on the outside of the building.

9. Generators must be constructed so that they can be charged with calcium carbide at all times without allowing the gas to escape into the building.

10. Generators shall be filled with calcium carbide by daylight only, and all generating apparatus must be in charge of persons who are familiar with their operation and are fully competent to manage them under all circumstances.

11. No artificial light, except a wire-guarded incandescent electric light, may be used inside of the building in which the gas is generated, and no heat except low-pressure steam.

12. All acetylene gas generators, and all receptacles containing acetylene gas, shall be made of iron or steel throughout.

13. The residuum of the calcium carbide when removed from the generator must be deposited in a safe location outside of the building apart from any combustible material.

LIQUID ACETYLENE.

14. The storage of liquid acetylene in any building, or the use of liquid acetylene gas, is absolutely prohibited.

UNITED STATES PATENTS ON
Calcium Carbide and Acetylene Apparatus

CARBIDE AND ELECTRIC FURNACES.

NUMBER.	DATE.	INVENTOR.	TITLE.
492,767	Jan. 28, 1893	Acheson, Edward G.	Production of artificial, crystalline, carbonaceous materials.
Reissue 11,473	Feb. 26, 1895		
541,137	June 18, 1895		
541,138	June 18, 1895		
551,461	Dec. 17, 1895	Clarke, William C.	Art of producing calcium carbide.
Reissue 11,511	Oct. 22, 1895	Willson, Thomas L.	Calcium carbide process.
552,036	Dec. 24, 1895	Böhm, Ludwig K.	Material for incandescent conductors.
552,890	Jan. 14, 1896	Clarke, William C.	Manufacture of calcium carbide.
555,796	Mar. 3, 1896	Whitehead, C.	Compound of magnesium and calcium carbide.
557,057	Mar. 24, 1896	Dickerson, Edward N.	Process and apparatus for producing metallic compounds by electricity.
560,291	May 19, 1896	Acheson, Edward G.	Electrical furnace.
562,402	June 23, 1896	King, William R., and Wyatt, Francis.	Process of forming calcium carbide.
563,527	July 7, 1896	Willson, Thomas L.	Process of producing calcium compounds.
563,528	July 7, 1896	Willson, Thomas L.	Process of manufacturing hydro-carbon gas.
571,084	Nov. 10, 1896	Eldridge, Hilliary, Clark, Daniel J., and Wambaugh, Mahlon W.	Composition of matter for manufacturing calcium carbide.
572,636	Dec. 8, 1896	Hewes, James E.	Electric furnace.
578,685	Mar. 9, 1897	Whitney, Edwin R.	Process and apparatus for producing calcium carbide.
583,498	June 1, 1897	Morehead, James T.	Manufacture of carbide of calcium.
587,138	July 27, 1897	Roberts, Isaiah L.	Process of and apparatus for manufacturing metallic carbides.

CARBIDE AND ELECTRIC FURNACES—*Continued.*

NUMBER.	DATE.	INVENTOR.	TITLE.
587,343	Aug. 3, 1897	Strong, George S.	Electric furnace.
587,509	Aug. 3, 1897	Roberts, Isaiah L.	Process of and apparatus for making metallic carbides.
588,012	Aug. 10, 1897	Roberts, Isaiah L.	Process of and apparatus for making metallic carbides.
588,866	Aug. 24, 1897	Kenevel, Jeannot W. ...	Means for manufacturing carbides.
589,592	Sept. 7, 1897	Blum, Sylvain.	Composition of matter for manufacturing calcium carbide.
589,967	Sept. 14, 1897	Heath, Robert F. S.	Composition for manufacturing calcium carbides.
590,514	Sept. 21, 1897	Cowles, Alfred H.	Process of producing metallic carbides.
597,945	Jan. 25, 1898	Bradley, C. S.	Electric furnace.

GENERATORS.

535,944	Mar. 19, 1895	Dickerson, Edward N. ..	Process of and apparatus for producing and liquefying acetylene gas.
541,429	June 18, 1895	Dickerson, Edward N. ..	Process and apparatus for producing gas.
541,428	June 18, 1895	Dickerson, Edward N. ..	Automatic gas-holder relief-valve.
541,427	June 18, 1895	Dickerson, Edward N. ..	Apparatus for production of gas.
541,526	June 25, 1895	Dickerson, Edward N. ..	Process of and apparatus for manufacture of gas.
542,320	July 9, 1895	Willson, Thomas R.	Process of and apparatus for manufacture of gas.
550,162	Nov. 19, 1895	Dickerson, Edward N. ..	Gas-governor.
552,027	Dec. 24, 1895	Willson, Thomas L.	Process of generating gas.
552,028	Dec. 24, 1895	Willson, Thomas L.	Apparatus for generating gas.
551,815	Dec. 24, 1895	Farnsworth, Ezra.	Apparatus for manufacture of gas.
552,048	Dec. 24, 1895	Dickerson, Edward N. ..	Process of and apparatus for mingling gases.
552,375	Dec. 31, 1895	Jones, Charles C.	Acetylene gas generator.
552,099	Dec. 31, 1895	Clarke, William C.	Apparatus for generating gas.
552,101	Dec. 31, 1895	Clarke, William C.	Apparatus for generating and supplying gas.
552,100	Dec. 31, 1895	Clarke, William C.	Apparatus for generating gas.
553,443	Jan. 21, 1896	Willson, Thomas R.	Process of carburetting water-gas.

GENERATORS—Continued.

NUMBER.	DATE.	INVENTOR.	TITLE.
553,550	Jan. 28, 1896	Willson, Thomas L.	Process of producing illuminating gas.
553,781	Jan. 28, 1896	Dickerson, Edward N ..	Apparatus for producing gas.
555,149	Feb. 25, 1896	Dickerson, Edward N ..	Process for and apparatus for burning liquefied gas.
555,198	Feb. 25, 1896	Willson, Thomas L.	Process of making and consuming gas.
555,212	Feb. 25, 1896	Dickerson, Edward N ..	Process of and apparatus for producing illuminating gas.
556,115	Mar. 10, 1896	Turney, E. T.	Process of and apparatus for producing illuminating gas.
556,736	Mar. 24, 1896	Clarke, William C.	Method of and apparatus for generating acetylene.
556,737	Mar. 24, 1896	Clarke, William C.	Method of generating illuminating gas.
556,910	Mar. 24, 1896	Wilkinson, A. W.	Process of manufacturing gas.
556,911	Mar. 24, 1896	Wilkinson, A. W.	Process of manufacturing gas.
558,746	April 21, 1896	De Sieghardt, O. T.	Apparatus for generating and storing acetylene gas.
559,846	May 12, 1896	Gray, G. J., and Hitchcock, W. F.	Apparatus for manufacturing acetylene gas.
560,405	May 19, 1896	Fuller, H. F.	Acetylene gas generator.
560,549	May 19, 1896	Seward, O. G., Mille, O. E., and Ham, M. J. ..	Automatic gas generator.
560,784	May 26, 1896	Dickerson, Edward N ..	Valve-locking mechanism for gas generators.
561,208	June 2, 1896	Dickerson, Edward N ..	Automatic acetylene gas apparatus.
561,701	June 9, 1896	Dickerson, Edward N ..	Process of producing acetylene gas.
562,040	June 16, 1896	Sergeant, H. C.	Gas generator.
562,401	June 23, 1896	King, W. R., and Wyatt, F.	Apparatus for generating acetylene gas.
562,911	June 30, 1896	Porter, J. C.	Acetylene gas generator.
563,457	July 7, 1896	Dickerson, Edward N ..	Acetylene gas generator.
563,980	July 14, 1896	Morley, J. H.	Acetylene gas generator.
563,981	July 14, 1896	Morley, J. H.	Acetylene gas generator.
564,684	July 28, 1896	Dickerson, Edward N ..	Gas-mixing device.
565,157	Aug. 4, 1896	Dickerson, Edward N ..	Gas-mixer.
566,660	Aug. 25, 1896	Clarke, H. B.	Acetylene generator and bicycle-lamp.
566,901	Sept. 1, 1896	Fuller, H. F.	Acetylene gas generator.
567,641	Sept. 15, 1896	Eldridge, H.	Gas-generating apparatus

GENERATORS—*Continued.*

NUMBER.	DATE.	INVENTOR.	TITLE.
567,773	Sept. 15, 1896	Rossback-Rousset, F ...	Gas-generating lamp.
569,273	Oct. 13, 1896	Bucher, A. S.	Acetylene gas generator.
569,208	Oct. 20, 1896	Exley, J. H.	Apparatus for manufacturing acetylene.
571,269	Nov. 10, 1896	Janeway, J. L.	Process of manufacturing gas.
571,576	Nov. 17, 1896	Porter, J. C.	Gas generator.
572,113	Dec. 1, 1896	Hill, W. P., and H. D..	Acetylene gas generator.
573,996	Dec. 29, 1896	Owen, R. L.	Gas-distributing apparatus.
573,938	Dec. 29, 1896	Waite, John H.	Acetylene gas generator.
574,601	Jan. 5, 1897	Casgrain, H. E.	Acetylene gas generating lamp.
575,281	Jan. 12, 1897	Buffington, L. S.	Apparatus for generating acetylene gas.
575,474	Jan. 19, 1897	Fuller, Henry F.	Gas generator for acetylene.
575,677	Jan. 19, 1897	Fuller, Henry F.	Method and apparatus for generating acetylene gas.
575,885.	Jan. 26, 1897	Fourchette, M. C. A....	Apparatus for producing acetylene gas.
575,884	Jan. 26, 1897	Fourchette, M. C. A....	Apparatus for producing acetylene gas.
576,386	Feb. 2, 1897	Voisard, E. P.	Acetylene gas generator.
576,585	Feb. 9, 1897	Kidder, Moses W.	Apparatus for generating acetylene gas.
576,826	Feb. 9, 1897	Sergeant, H. C.	Generator for making acetylene gas.
576,529	Feb. 9, 1897	Addicks, W. R.	Apparatus for manufacturing gas.
576,827	Feb. 9, 1897	Sergeant, H. C.	Acetylene gas holder.
576,893	Feb. 9, 1897	Reynolds, D. J.	Acetylene gas generator.
576,955	Feb. 9, 1897	Deuther, J. A.	Method of and apparatus for generating gas.
577,051	Feb. 16, 1897	Matthews, Charles, Jr..	Acetylene gas generator.
577,803	Feb. 23, 1897	Willson, Thomas L.	Process of producing and consuming hydro-carbon gas.
577,706	Feb. 23, 1897	Archer, G. S., and Burington, C. F.	Acetylene gas generator.
577,762	Feb. 23, 1897	Lawrence, R. S.	Apparatus for increasing candle-power of gas.
578,055	Mar. 2, 1897	Fuller, Henry F.	Acetylene gas generator.
578,847	Mar. 16, 1897	Wilcox, Clementina H..	Acetylene gas generator.
578,972	Mar. 16, 1897	Couper, J. H.	Acetylene gas generator.
579,702	Mar. 30, 1897	Dickerson, Edward N. ...	Acetylene gas producing apparatus.
579,689	Mar. 30, 1897	Vincent, J. A.	Acetylene gas producing apparatus.

GENERATORS—*Continued.*

NUMBER.	DATE.	INVENTOR.	TITLE.
580,624	April 13, 1897	Napheys, E. C.....	Acetylene gas producing apparatus.
580,650	April 13, 1897	Reynolds, D. J.....	Acetylene gas generator.
581,020	April 20, 1897	Dennis, William H.....	Acetylene gas generating lamp.
581,699	May 4, 1897	Doddridge, A. F.....	Apparatus for generating acetylene gas.
582,274	May 11, 1897	Dickerson, Edward N..	Apparatus for gasifying and controlling liquefied or compressed gas.
582,546	May 11, 1897	Patterson, J. J.....	Apparatus for generating acetylene gas.
582,548	May 11, 1897	Rand, Charles E.....	Process of generating acetylene gas.
583,582	June 1, 1897	Rhind, Frank.....	Gas generating lamp.
583,761	June 1, 1897	Mitchell, F. A.....	Acetylene gas generator.
584,339	June 15, 1897	Exley, J. H.,.....	Apparatus for manufacturing acetylene gas.
584,772	June 22, 1897	Dickerson, Edward N., and Suckert, J. J.	Apparatus for burning acetylene gas.
584,931	June 22, 1897	Fuller, H. F.....	Acetylene gas generator.
584,946	June 22, 1897	Luckenbach, R.....	Acetylene gas apparatus.
585,625	June 29, 1897	Dougherty, J. F.....	Acetylene gas generator.
585,642	June 29, 1897	Gallagher, J. C.....	Gas generator for lamps.
586,194	July 13, 1897	Matthews, C., Jr.....	Acetylene gas apparatus.
586,517	July 13, 1897	Hawley, C. G.....	Acetylene gas lamp.
587,914	Aug. 10, 1897	Becherel, C. F. J. B....	Apparatus for producing acetylene gas.
588,230	Aug. 17, 1897	Mackusick, E. F.....	Process of generating gas from carbide.
588,535	Aug. 17, 1897	Simonson, F.....	Acetylene gas generator.
588,593	Aug. 24, 1897	Morency, D. C.....	Apparatus for generating acetylene gas.
589,404	Sept. 7, 1897	Bettini, G.....	Acetylene gas lamp.
589,713	Sept. 7, 1897	Gallagher, J. C.....	Process and apparatus for generating acetylene gas.
589,799	Sept. 7, 1897	Taylor, George.....	Acetylene gas generator.
590,441	Sept. 21, 1897	Reynolds, D. J.....	Acetylene gas generator.
590,674	Sept. 28, 1897	Strom, A. A.....	Apparatus for generating acetylene gas.
590,592	Sept. 28, 1897	Pyle, H. L., Lichtenstein, L., and Brison, J. C.	Apparatus for generating acetylene gas.
590,941	Sept. 28, 1897	Beck, Charles W.....	Lamp for generating and burning acetylene gas.
590,955	Oct. 5, 1897	Beck, Charles W.....	Acetylene gas lamp.
591,132	Oct. 5, 1897	Handshy, H. M.....	Acetylene gas lamp.
591,367	Oct. 5, 1897	Beck, Charles W.....	Acetylene gas lamp.
592,083	Oct. 19, 1897	Dupee, J. C.....	Acetylene gas generator.
592,084	Oct. 19, 1897	Dupee, J. C.....	Acetylene gas generator.

GENERATORS—*Continued.*

NUMBER.	DATE.	INVENTOR.	TITLE.
592,759	Nov. 2, 1897	Bellamy, C. H.....	Apparatus for generating acetylene gas.
593,122	Nov. 2, 1897	Raymond, J. M., and Lemley, L. E.	Acetylene gas generator.
593,628	Nov. 16, 1897	Williams, B. F.....	Generator for acetylene gas.
594,175	Nov. 23, 1897	Hellwig, Otto S ..	Acetylene gas generator.
594,826	Nov. 30, 1897	Ferguson, J. S	Acetylene gas generator.
594,849	Dec. 7, 1897	Bettini, G.....	Acetylene gas generator.
595,119	Dec. 7, 1897	Couper, J. H.....	Acetylene gas generator.
595,230	Dec. 7, 1897	Whittemore, L. D., Jr..	Combined lamp and acetylene generator.
595,451	Dec. 14, 1897	Choquette, C. P., and Morin, A. M.....	Acetylene gas generator.
595,621	Dec. 14, 1897	Gobron, A.....	Acetylene gas generating lamp.
595,668	Dec. 14, 1897	Bryant, H	Acetylene gas machine.
595,816	Dec. 21, 1897	Lebrun, G., and Cornaille, F.	Apparatus for producing acetylene gas.
595,924	Dec. 21, 1897	Ruhe, W. A., and Burbank, H. S.	Acetylene gas apparatus.
596,139	Dec. 28, 1897	Bolton, Werner	Process of generating acetylene gas.
596,144	Dec. 28, 1897	Dolan, E. J..	Burner for rich gases, especially acetylene gas.
596,138	Dec. 28, 1897	Blanchard, D. R.	Acetylene gas generator.
596,112	Dec. 28, 1897	Henkle, L., and Goddard, F. H.....	Acetylene gas burner.
596,577	Jan. 4, 1898	Dolan, E. J.....	Acetylene gas burner.
596,578	Jan. 4, 1898	Dolan, E. J.....	Acetylene gas burner.
596,703	Jan. 4, 1898	Harrison, P. R.....	Acetylene gas generating lamp.
596,937	Jan. 4, 1898	Kerr, J. G.....	Acetylene gas apparatus.
597,291	Jan. 11, 1898	Leede, J.....	Acetylene gas apparatus.
597,495	Jan. 18, 1898	Dolan, E. J.....	Acetylene gas heater.
597,937	Jan. 25, 1898	Bell, H. J.....	Acetylene generator.
598,048	Jan. 25, 1898	Carter, R. F.....	Apparatus for producing acetylene gas.
598,213	Feb. 1, 1898	Wilson, C. L., Unger, J. W., Muma C., Brosius, A. P., and Kuchel, J. C.....	Acetylene gas generator.
598,767	Feb. 8, 1898	Carter, R. F.....	Apparatus for producing acetylene gas.
598,837	Feb. 8, 1898	Appleby, E	Acetylene gas apparatus.
598,868	Feb. 8, 1898	Hardwick, J. L., and Manville, S. O.....	Acetylene gas generator.
599,074	Feb. 15, 1898	Dederick, Z. P.....	Acetylene gas generator.
599,098	Feb. 15, 1898	Hanotier, V., and Hostelet, G.	Apparatus for producing acetylene gas.

GENERATORS—*Continued.*

NUMBER.	DATE.	INVENTOR.	TITLE.
599,198	Feb. 15, 1898	Serres, L.	Lamp for generating acetylene gas.
599,270	Feb. 15, 1898	Stein, A. K.	Apparatus for generating acetylene gas
599,347	Feb. 22, 1898	McMurray, P.	Acetylene gas generator.
599,394	Feb. 22, 1898	Laun, H. W. and E. E.	Acetylene gas generator.

**THE LIBRARY
UNIVERSITY OF CALIFORNIA
Santa Barbara**

**THIS BOOK IS DUE ON THE LAST DATE
STAMPED BELOW.**

UC SOUTHERN REGIONAL LIBRARY FACILITY



A 000 579 104 1

