



554

SCIENTIFIC LIBRARY



UNITED STATES PATENT OFFICE

CASE SHELF

GOVERNMENT PRINTING OFFICE

11-8625

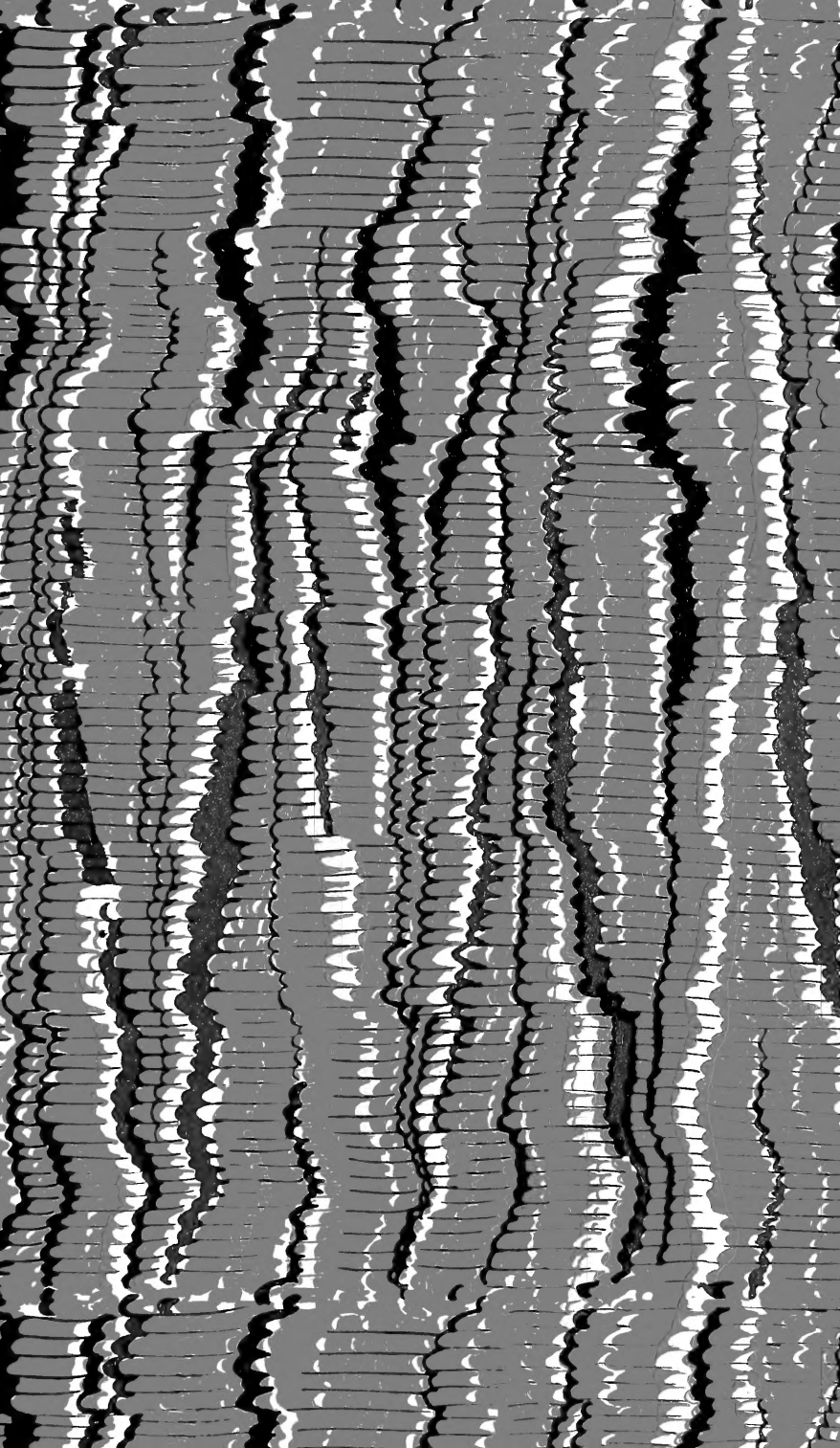



LIBRARY

FEB 19 1930

U. S. PATENT OFFICE



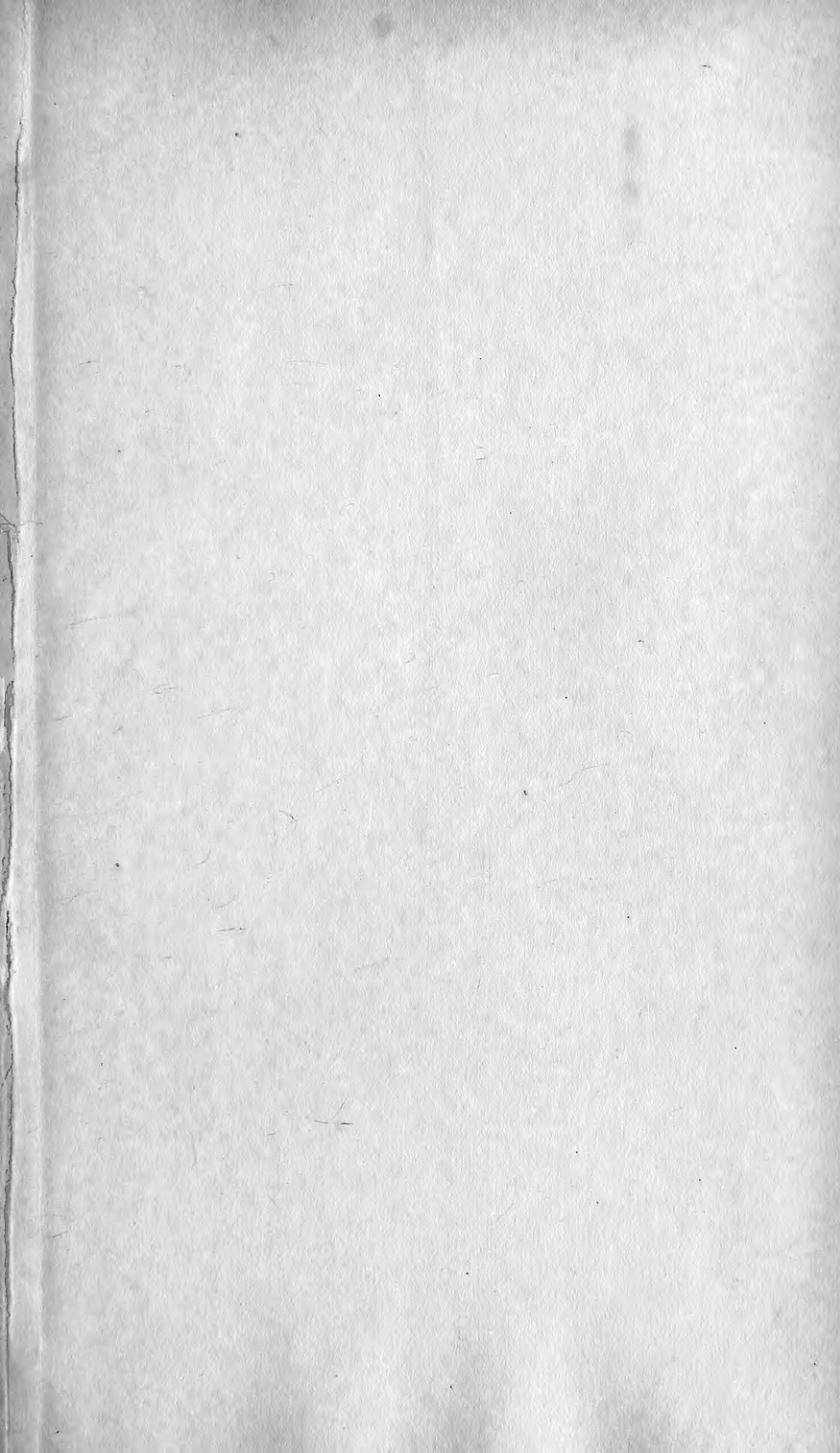

Q 13
2

71417
Book
10
L. 2

THE
LONDON, EDINBURGH, AND DUBLIN
PHILOSOPHICAL MAGAZINE
AND
JOURNAL OF SCIENCE.

CONDUCTED BY
LORD KELVIN, G.C.V.O. D.C.L. LL.D. F.R.S. &c.
GEORGE FRANCIS FITZGERALD, M.A. Sc.D. F.R.S.
AND
WILLIAM FRANCIS, Ph.D. F.L.S. F.R.A.S. F.C.S.

"Nec aranearum sane textus ideo melior quia ex se fila gignunt, nec noster vilior quia ex alienis libamus ut apes." Just. Lips. *Polit.* lib. i. cap. 1. Not.

VOL. L.—FIFTH SERIES.
JULY—DECEMBER 1900.

LONDON:
TAYLOR AND FRANCIS, RED LION COURT, FLEET STREET.
SOLD BY SIMPKIN, MARSHALL, HAMILTON, KENT, AND CO., LD.; WHITTAKER AND CO.;
AND BY ADAM AND CHARLES BLACK;—T. AND T. CLARK, EDINBURGH;
SMITH AND SON, GLASGOW;—HODGES, FIGGIS, AND CO, DUBLIN;—
PUTNAM, NEW YORK,—VEUVE J. BOYVEAU, PARIS;—
AND ASHER AND CO., BERLIN.

75584

201

Q
1
P5

“Meditationis est perscrutari occulta; contemplationis est admirari perspicua . . . Admiratio generat quæstionem, quæstio investigationem, investigatio inventionem.”—*Hugo de S. Victore.*

—“Cur spirent venti, cur terra dehiscat,
Cur mare turgescat, pelago cur tantus amaror,
Cur caput obscura Phœbus ferrugine condat,
Quid toties diros cogat flagrare cometas,
Quid pariat nubes, veniant cur fulmina cœlo,
Quo micet igne Iris, superos quis conciat orbes
Tam vario motu.”

J. B. Pinelli ad Mazonium.

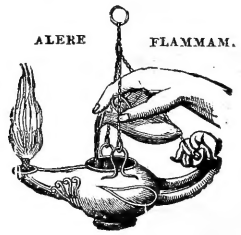

CONTENTS OF VOL. L.

(FIFTH SERIES).

NUMBER CCCII.—JULY 1900.

	Page
Mr. R. L. Wills on the Effects of Temperature on the Magnetic Properties of Iron and Alloys of Iron	1
Mr. J. B. Tayler on the Heat of Formation of Alloys	37
Dr. Charles Davison on Scales of Seismic Intensity	44
Prof. H. Nagaoka on the Elastic Constants of Rocks and the Velocity of Seismic Waves	53
Mr. James J. Guest on the Strength of Ductile Materials under Combined Stress	69
Prof. John Trowbridge on the Production of the x -Rays by a Battery Current	132
Lord Rayleigh on Approximately Simple Waves	135
Mr. R. Beattie on the Spark-Length of an Induction-Coil..	139
Prof. R. W. Wood on Photography of Sound-waves, and the Kinematographic Demonstration of the Evolutions of Reflected Wave-fronts	148
Prof. Karl Pearson on the Criterion that a given System of Deviations from the Probable in the Case of a Correlated System of Variables is such that it can be reasonably supposed to have arisen from Random Sampling	157
Notices respecting New Books :—	
Jacques Boyer's <i>Histoire des Mathématiques</i>	176
Eilhard Wiedemann and Hermann Ebert's <i>Physikal- isches Praktikum</i>	177
Dr. O. E. Meyer's <i>Kinetic Theory of Gases</i>	177
Proceedings of the Geological Society :—	
Mr. John Parkinson on the Rocks of the South-eastern Coast of Jersey, and on the Rocks of La Saline (North Jersey)	179-180

NUMBER CCCIII.—AUGUST.

	Page
Lord Kelvin on the Motion produced in an Infinite Elastic Solid by the Motion through the Space occupied by it of a Body acting on it only by Attraction or Repulsion	181
Prof. Louis T. More on the Supposed Elongation of a Dielectric in an Electrostatic Field	198
Lord Rayleigh on a Theorem analogous to the Virial Theorem.	210
Mr. R. F. Gwyther on the Classes of Progressive Long Waves.	213
Prof. A. W. Bickerton on Cosmic Evolution	216
K. Tsuruta on some Effects of Twist on the Thermo-electric Qualities of Iron	223
Dr. J. H. Gladstone on the Want of Uniformity in the Action of Copper-Zinc Alloys on Nitric Acid	231
Mr. Harold A. Wilson on the Velocity of Solidification and Viscosity of Supercooled Liquids	238
Mr. J. Rose-Innes on the Theory of the Constant-volume Gas-thermometer	251
Mr. John Buchanan on Torsion-Structure in the Alps	261
Proceedings of the Geological Society :—	
Miss Ethel Wood on the Lower Ludlow Formation and its Graptolite-Fauna	265
Mr. Frank Rutley on some Eruptive Rocks from New Zealand	267
Baron A. E. Nordenskiöld on the Discovery and Occurrence of Minerals containing Rare Elements	268

NUMBER CCCIV.—SEPTEMBER.

Prof. W. McF. Orr: Considerations regarding the Theory of Electrons	269
Prof. J. J. Thomson on the Genesis of the Ions in the Discharge of Electricity through Gases	278
Mr. Philip E. Shaw on some Lecture Experiments illustrating Syntony	283
Prof. Sydney Young on the Law of Cailletet and Mathias and the Critical Density	291
Lord Kelvin on the Duties of Ether for Electricity and Magnetism	305
Mr. R. F. Gwyther's Appendix to the Paper on the Classes of Progressive Long Waves	308

	Page
Mr. John Stevenson on the Chemical and Geological History of the Atmosphere	312
Mr. H. S. Allen on the Motion of a Sphere in a Viscous Fluid	323
Prof. J. Trowbridge on the Spectra of Hydrogen and the Spectrum of Aqueous Vapour	338
Prof. R. W. Wood on an Application of the Method of Striæ to the Illumination of Objects under the Microscope. (Plate III.)	347
Mr. R. F. Gwyther on the General Motion of Long Waves, with an Examination of the Direct Reflexion of the Solitary Wave	349
Proceedings of the Geological Society :—	
Dr. Charles Callaway on Longmyndian Inliers at Old Radnor and Huntley (Gloucestershire)	352
Mr. F. W. Harmer on the Pliocene Deposits of the East of England	353
Mr. C. V. Bellamy on the Salt Lake of Larnaca in the Island of Cyprus	356

NUMBER CCCV.—OCTOBER.

Messrs. Edwin H. Barton and Louis Lownds on the Reflexion and Transmission by Condensers of Electric Waves along Wires	357
Mr. W. F. Sheppard on the Tabulation of certain Frequency Distributions	393
Mr. John Stevenson on the Chemical and Geological History of the Atmosphere	399
Mr. R. J. A. Barnard on the Annual March of Temperature.	408
Mr. R. T. Glazebrook on the Measurement of some Standard Resistances	410
Mr. H. E. Wimperis on Experiments on the Elasticity of Wires	416
Mr. H. M. Tory on a Comparison of Platinum Thermometers of different degrees of Purity	421
Dr. P. Chappuis on Gas-Thermometry	433
Proceedings of the Geological Society :—	
Mr. F. R. Cowper Reed on the Igneous Rocks of the Coast of County Waterford	443
Messrs. J. B. Hill and H. Kynaston on a New Type of Rock from Kentallen and Elsewhere, and its Relations to other Igneous Rocks in Argyllshire	444

NUMBER CCCVI.—NOVEMBER.

	Page
T. Mizuno on the Action of the Coherer	445
Mr. William Sutherland on the Molecular Constitution of Water	460
Mr. W. Craig Henderson on Experiments to Determine whether a Liquid when Electrified loses any portion of its Charge by Evaporation.....	489
Mr. Henry Crew on the Arc Spectra of some Metals, as influenced by an Atmosphere of Hydrogen	497
Prof. J. G. MacGregor on a Diagram of Freezing-point Depressions for Electrolytes. (Plate IV.).....	505
Mr. H. S. Allen on the Motion of a Sphere in a Viscous Fluid. (Plates I. & II.)	519
Notices respecting New Books :—	
W. Ostwald's Grundriss der Allgemeinen Chemie.....	534
Proceedings of the Geological Society :—	
Dr. J. W. Evans on Mechanically-formed Limestones from Junagarh and other Localities	536

NUMBER CCCVII.—DECEMBER.

Mr. Philip E. Shaw on an Electric Micrometer.....	537
Dr. Clarence A. Skinner on the Potential Gradient in the so-called Faraday Dark Space of Vacuum-Tubes as Related to Conditions prevalent at the Cathode	563
Mr. R. Beattie on a Possible Source of Error in the Use of a Ballistic Galvanometer	575
Dr. Charles Davison on the Sea-Waves connected with the Japanese Earthquake of June 15, 1896. (Plate V.)	579
Mr. S. H. Burbury on the Law of Partition of Energy	584
Prof. C. Barus on the Rates of a Rocking Watch, with Remarks on a Gravitational Pendulum	595
Prof. W. B. Morton on some Cases of Propagation of Electric Oscillations along a Number of Parallel Wires	605
Notices respecting New Books :—	
The Scientific Papers of John Couch Adams. Vol. II... ..	617
New Researches into Pouillet's Phenomenon (the Heat Developed in Wetting Powders), by Tito Martini.....	618
Index	620

PLATES.

- I. & II. Illustrative of Mr. H. S. Allen's Paper on the Motion of a Sphere in a Viscous Fluid.
- III. Illustrative of Prof. R. W. Wood's Paper on an Application of the Method of Striæ to the Illumination of Objects under the Microscope.
- IV. Illustrative of Prof. J. G. MacGregor's Paper on a Diagram of Freezing-point Depressions for Electrolytes.
- V. Illustrative of Dr. C. Davison's Paper on the Sea-Waves connected with the Japanese Earthquake of June 15, 1896.

ERRATA.

P. 196, last line, formula (16), *for*

$$V/(1+N \frac{\pi}{6} s^3 \cdot 634) \quad \textit{read}$$

$$V/(1+N \frac{\pi}{6} s^3 \cdot 634)^{\frac{1}{2}}$$

P. 197, line 14, *for* .6 *read* .6 $\times 10^{-3}$

P. 306, line 11, *for* attraction *read* repulsion

„ line 13, *for* repulsion *read* attraction

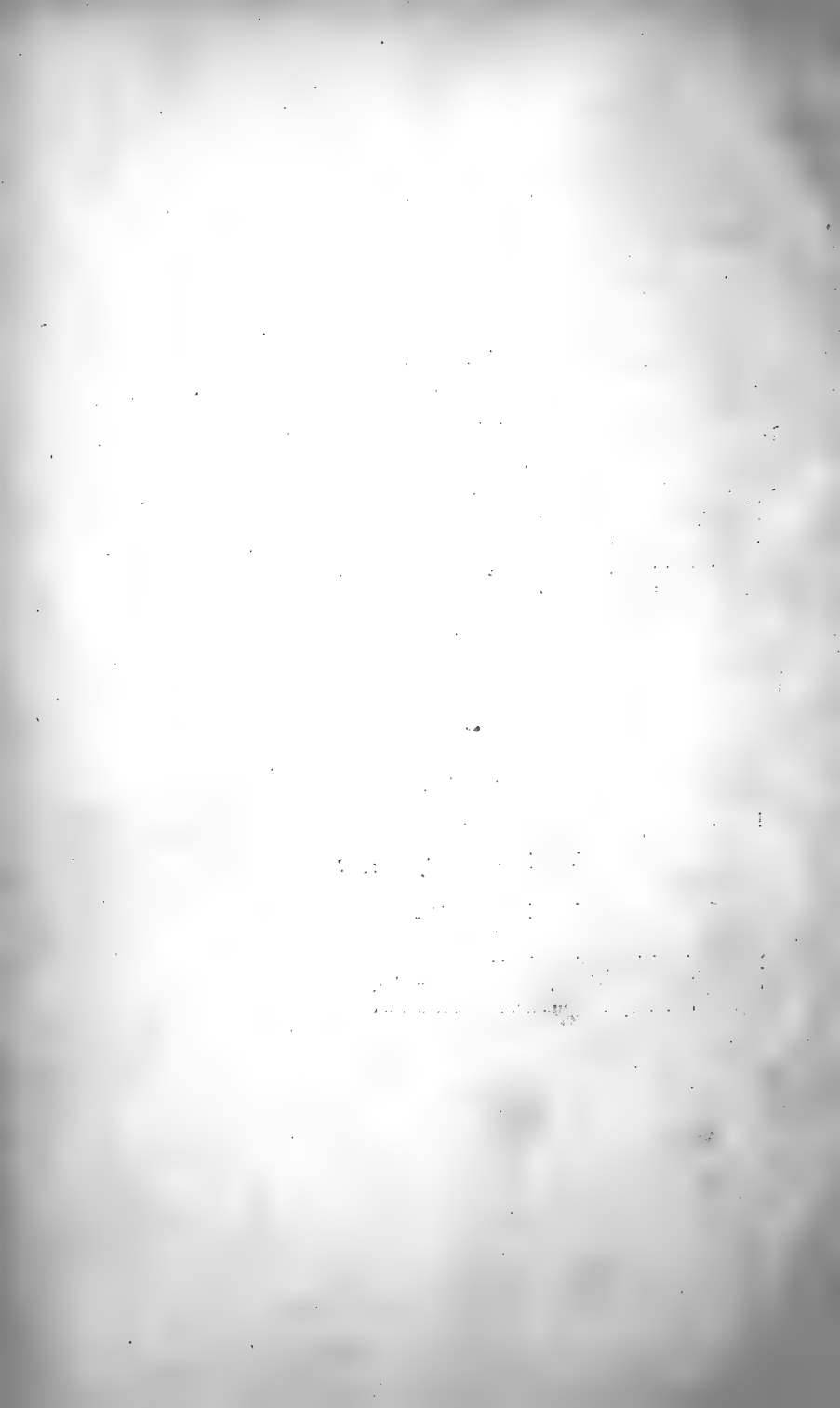

THE
LONDON, EDINBURGH, AND DUBLIN
PHILOSOPHICAL MAGAZINE
AND
JOURNAL OF SCIENCE.

[FIFTH SERIES.]

JULY 1900.

I. *Effects of Temperature on the Magnetic Properties of Iron and Alloys of Iron.* By R. L. WILLS, A.R.C.Sc.I., 1851 Exhibition Scholar, St. John's College, Cambridge*.

THE experiments of Baur †, Hopkinson ‡, Morris §, and others on the effects of temperature on the magnetic quality of iron show that as the temperature is raised the magnetization for small magnetizing forces increases, at first gradually, but beyond a temperature of about 600° C. the permeability increases very rapidly until the critical temperature is approached, when the magnetization suddenly disappears.

The maximum permeability obtained by Hopkinson was about 11,000 with a magnetizing force of 0·3 c.g.s. at a temperature of 775° C. The rise in permeability is less and less as the magnetic force is increased; with a force of 4 c.g.s. the permeability remains practically constant as the temperature is raised till about 700° C. is reached, then the permeability falls, but much more gradually than with lower magnetizing forces.

To explain these results Professor Ewing || has applied a modification of Weber's molecular theory, in which the constraint of the molecules is supposed due to their mutual action as magnets.

* Communicated by Prof. J. J. Thomson, F.R.S.

† Wied. Ann. xi. p. 407 (1880).

‡ Phil. Trans. vol. clxxx. A. pp. 443-465 (1889).

§ Phil. Mag. September 1897, pp. 229-230.

|| Proc. Roy. Soc. vol. xlviii. pp. 215-216 (1890). See Ewing's

'Magnetic Induction in Iron and other Metals,' chap. xi.

Phil. Mag. S. 5. Vol. 50. No. 302. July 1900.

The magnetizing process, according to Weber's theory, consists in turning the molecular magnets so that the magnetic axis of each is in the same direction as the applied magnetizing force. When the force is weak the molecules will be but slightly deflected; as the force is increased the molecules are brought more nearly into alignment till, with a very strong force, they are all parallel with the field and the specimen is saturated.

Prof. Ewing * divides the magnetizing process of magnetic metals into three stages. During the first stage the permeability is small and there is practically no retentiveness. In the second stage the curve of magnetization rises rapidly and the permeability is high. In the third stage the permeability decreases and the specimen approaches saturation.

The effect of heat is regarded as making the transition from one stage of the magnetizing process to another occur at lower values of the magnetic force. Heating expands the structure and weakens the mutual forces between the molecular magnets, thus enabling the applied magnetizing force to have a greater effect in turning the molecules. Oscillations are supposed to be set up as the temperature rises which oppose the alignment of the magnets, and by supposing the oscillations to become so violent that the magnets eventually rotate, the disappearance of magnetism at the critical temperature would be accounted for.

The temperature effect appears to have been studied only for magnetizing forces so large that the heat applied has brought on the second stage of the magnetizing process, and before the magnetic quality disappears the third stage has even been entered upon. From this it would appear that by using successively smaller magnetizing forces, so that less of the third stage is brought on before the critical condition is reached, the permeability will rise more rapidly with the temperature, and with a suitable relation of force to temperature the permeability will be the maximum obtainable. With lower magnetizing forces than this critical value the temperature required to bring on the second stage will be higher, and only a part of this stage is brought on before the critical temperature is reached and magnetic quality lost. As the magnetizing force is further reduced the maximum permeability obtained in each case decreases, and in extremely weak fields it appears quite possible that the critical temperature is reached before even the second stage is brought on.

The experiments described in this paper were undertaken

* "Contributions to the Molecular Theory of Induced Magnetism," Proc. Roy. Soc. vol. xlviii. pp. 347-350 (1890).

primarily to investigate the effect of heat on the magnetic properties of certain alloys of iron, which, at the ordinary temperature, had been previously found to give very different magnetic results when in different physical conditions.

It appeared desirable to examine the effect of heat on the magnetic properties of wrought iron in weak fields, to see when, as the temperature is raised, the successive stages of the magnetizing process are brought on, and to obtain some idea as to the rate of transition from stage to stage.

The specimens were obtained from Messrs. Brunton & Son, of Musselburgh, and were in the form of rings turned out of solid blocks and annealed. The magnetization was measured ballistically by reversing the magnetizing force, the arrangement of the apparatus being very similar to that used by Ewing and Klaassen*.

The copper wire was insulated with asbestos paper, and thin asbestos tape laid between the primary and secondary coils.

The temperatures were estimated by the resistances of the secondary coil and a platinum wire; it was found that after successive heating and cooling the resistance of the secondary coil increased, at first very slightly, but after a time the increase was proportionately large. A platinum wire was wound around the ring between the primary and secondary coils and its resistance measured as well as the resistance of the secondary at each temperature.

The specimens were heated in a Fletcher's improved muffle furnace, and the temperature regulated by the supply of gas. Before each experiment sufficient time was allowed to get the temperature steady, and it was found that in each case the temperature remained constant within 3° C. during each set of readings.

Wrought Iron Ring.

The dimensions of the ring were as shown:—

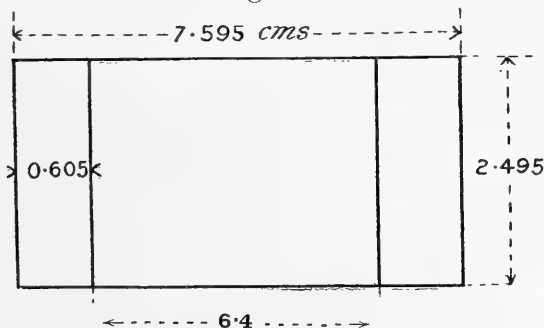

* Phil. Trans. vol. clxxxiv. A. p. 987 (1893).

Sectional area = 1.50 sq. cms.
 No. of turns in primary coil 75
 „ „ secondary coil 50

Mean value of magnetizing force per ampere of current = 4.3 c.g.s.

The induction corresponding to a ballistic throw of one scale-division on reversing the current when there was no additional resistance in the secondary circuit was 9.334.

The specimen was first demagnetized by reversals of current, by passing currents successively diminishing in amount to zero and rapidly alternating in direction through the primary, any initial magnetism the ring may have possessed was thus got rid of.

Magnetizing currents were next passed through the primary circuit while the ring was at the ordinary temperature of the room; each current was reversed several times and the kicks in the galvanometer noted.

The results, reduced to c.g.s. units, were:—

H.	μ .	H.	μ .	H.	μ .	H.	μ .
0.086	379	1.72	3084	3.01	3129	12.9	1124
0.344	543	1.935	3245	4.30	2606	17.2	858
0.688	814	2.15	3273	6.02	2089		
1.075	1299	2.58	3231	8.60	1581		

where H represents the magnetizing force and μ the permeability.

The passage from one stage of the magnetizing process to another is gradual, taking place through a definite range of magnetic force. Nagaoka* has shown for nickel that the passages from stage to stage can be made much more abrupt by applying torsion with a longitudinal pull.

For the present purpose it will be more convenient to represent the results of experiment by plotting permeability as ordinates instead of induction, showing the relation between permeability and magnetic force.

Fig. 1 represents the curve thus obtained from the data given above. The permeability reaches a maximum with a magnetizing force of about 2 c.g.s., and when the third stage of the magnetizing process is entered upon the permeability falls very rapidly.

Corresponding curves for higher temperatures are very

* Journal of the College of Science of the University of Tokio, vol. ii. p. 304 (1888).

similar to one another, the maximum permeability in each case occurring at values of the magnetic force depending on the temperature.

Plotting the curves for different temperatures and observing the force at which the maximum permeability occurs in

Fig. 1.

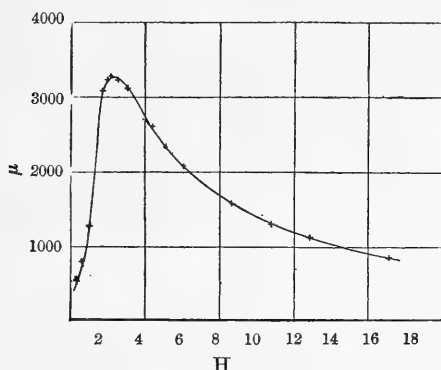

each case, we may obtain some idea as to how much earlier in the magnetizing process the successive stages are brought on by heating to any temperature, and from this ascertain the rate of transition from stage to stage as the temperature is raised.

The ring was next very slowly heated and the following results obtained with a constant magnetizing force of 6.45 C.G.S. :—

Temp. in deg. C. } 15°	223°	391°	577°	712°	743°	766°
Induction per sq. cm. } 12991	12991	12883	12233	8877	3247	93

It will be seen the induction remains practically constant as the ring is heated until the temperature reaches about 400° C.; then the induction falls, at first slowly, but more rapidly when a temperature of about 700° C. is passed, and the specimen becomes practically non-magnetic at about 776° C. The ring was heated slightly above the critical temperature and a very slight movement in the galvanometer on reversing the magnetizing current observed.

Readings were taken at various temperatures as the gas was lowered with the same magnetizing force; the magnetic quality returns as rapidly as it disappeared, but at a slightly lower temperature.

Various magnetizing forces were afterwards used and curves plotted showing the relation between permeability and temperature corresponding to heating and cooling. In each case the permeability reaches the same maximum value during cooling as on heating, and for each magnetizing force the heating and cooling curves are very similar.

The ring was afterwards examined in successive experiments at different temperatures, the magnetic force was varied while the temperature was kept constant, and from these results permeability-temperature curves were drawn for various magnetizing forces. The curves obtained compare satisfactorily with those given by Hopkinson* for corresponding fields.

A few special cases will be given here to show the effect of heat on the permeability as the magnetizing force is varied between two values, the larger of which brings on the second or third stage before any heat is applied, while the smaller is unable to bring on the second stage before the critical temperature is reached.

In each experiment the observations were repeated several times with reversed directions of magnetizing force, and after each experiment the ring was demagnetized by reversals as explained above.

A magnetizing force of 4.3 C.G.S. gave the following values for the permeability at the temperatures noted:—

Temp. in } deg. C. }	15°	174°	260°	367°	430°	482°	592°	645°	735°	748°	767°
μ	2606	2693	2719	2769	2744	2744	2593	2568	1682	1477	122

shown graphically in fig. 2.

Fig. 2.

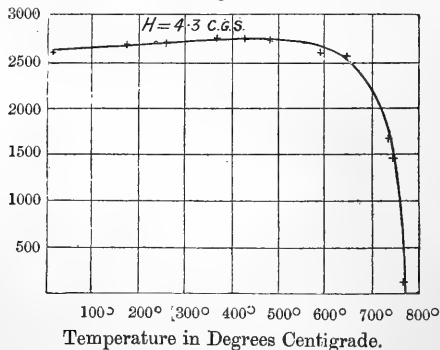

* Phil. Trans. vol. clxxx. plate xiv. (1889).

It will be seen that the permeability increases slightly as the temperature is raised to about 500°C . ; beyond this temperature the permeability falls, at first slowly, but with great rapidity as the critical temperature is approached.

The explanation given by Professor Ewing for the results of experiment with a field-strength giving a permeability-temperature curve similar to fig. 2 is that heating facilitates the alignment of the molecular magnets by weakening their mutual forces, but the permeability does not rise appreciably owing to the influence of oscillations supposed to be set up as the temperature rises which oppose the alignment of the magnets. This latter effect increases very rapidly as the critical point is approached and the permeability falls.

With fairly strong fields, such that the third stage of the magnetizing process is brought on before any heat is applied, there is no appreciable increase in permeability as the temperature rises, and the change from the magnetic to the non-magnetic state takes place comparatively gradually.

The curves drawn for successively smaller magnetizing forces show that as the force is reduced the temperature at which the permeability begins to fall increases. This may be accounted for by the molecular magnets being less deflected under weaker forces, and consequently the temperature necessary to bring them parallel with the field will be higher.

It is seen from fig. 1 that the permeability decreases very rapidly as the field is increased beyond the second stage; consequently, by reducing the magnetic force so that less of the third stage is entered upon before the magnetic quality is lost, heating is more favourable to magnetization.

The following values for the permeability at the temperatures given were obtained with a force of 1.075 c.g.s., and are shown plotted in fig. 3.

Fig. 3.

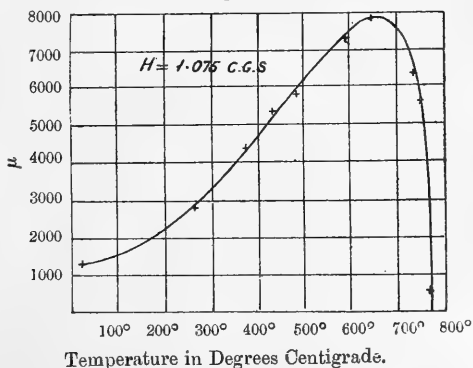

Temp. in } deg. C. }	15°	260°	367°	430°	482°	592°	645°	735°	748°	767°
μ	1299	2788	4320	5305	5743	7250	7805	6300	5579	473

In this case the second stage is just entered upon before any heat is applied, the permeability consequently increases as shown immediately the temperature is raised. At about 650° C. the prejudicial effect of temperature becomes stronger and the permeability falls.

With a magnetizing force of 0.688 c.g.s. the results were:—

Temp. } deg. C. }	15°	174°	260°	367°	482°	592°	645°	735°	748°	767°
μ	814	1180	1315	2228	4208	8204	9999	9315	8375	733

As the magnetizing force is reduced the increase in permeability during the earlier stages of heating gets less; but at the higher temperatures the permeability increases more rapidly, and the change from the magnetic to the non-magnetic state becomes more and more abrupt. This is because less of the third stage of the magnetizing process is entered upon before the critical temperature is reached; and consequently the rate of increase of permeability at high temperatures will be greater.

Reducing the magnetizing force still more, the maximum permeability obtained in each case and the temperature at which it occurs increase, until with a force of 0.172 c.g.s. the maximum permeability is practically 17,000 at a temperature of about 750° C.

The values of the permeability at different temperatures with this magnetizing force were:—

Temp. in } deg. C. }	15°	174°	260°	367°	482°	592°	645°	735°	748°	767°
μ	461	542	597	759	1085	1790	2985	14852	17228	2632

shown graphically in fig. 4.

Corresponding curves were drawn for lower magnetizing forces. The temperature at which the rapid rise in permeability begins increases as the magnetic force is reduced, and the maximum permeability obtained in each case diminishes. This is just what we should expect, seeing that with weaker fields the temperature necessary to bring on the second stage is higher, and therefore less of this stage is entered upon before the critical temperature is reached.

Fig. 4.

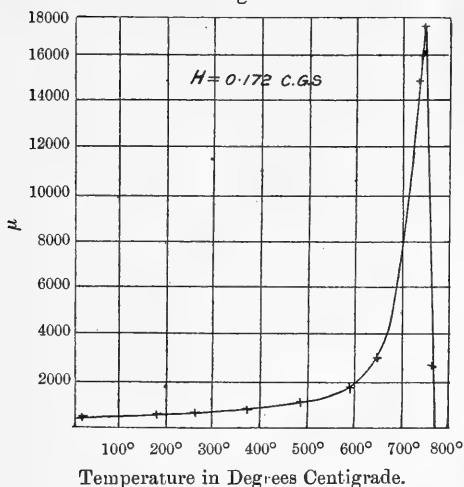

The following values were obtained with a force of about 0.0285 c.g.s.:—

Temp. in } 15°	260°	482°	592°	645°	735°	748°	767°
deg. C. }							
μ	327	491	819	1310	2620	3275 6175

With still weaker fields the kicks in the galvanometer on reversing the magnetizing currents were very small, and the calculated permeability could not be relied upon with any degree of accuracy; but from the observations taken with a magnetic force as low as 0.009 c.g.s. the permeability was found to increase rapidly as a temperature of 770° C. was approached, from which it would appear that even with this very weak field the second stage is brought on before the critical temperature is reached.

If the effect of heat in hastening the transition from stage to stage is uniform—that is, proportional to the temperature—there will be no sudden increase in the permeability as the temperature is raised until the second stage is entered upon; but if the rate of transition increases with the temperature, a considerable augmentation of susceptibility can be thus accounted for without assuming that the second stage is brought on.

Figs. 2, 3, and 4 are given to show the relation between permeability and temperature under magnetic forces which bring on the respective stages of the magnetizing process before any heat is applied. It will be seen (fig. 2) that with a fairly strong field the permeability is only slightly affected

until the temperature is rather high, owing to the gradient of the curve of magnetization in the third stage being small. With a field slightly above 1 c.g.s. the second stage is just entered upon while the metal is cold, and a small increase in the strength of the field makes a very considerable increase in the permeability. In this case the first effect of heating is to bring on more of the second stage; consequently the permeability rises as in fig. 3. In the first stage the gradient of the curve of magnetization is again small; and therefore with weak fields the permeability increases but slightly throughout a wide range of temperature as in the case of a moderately strong field.

Fig. 5.

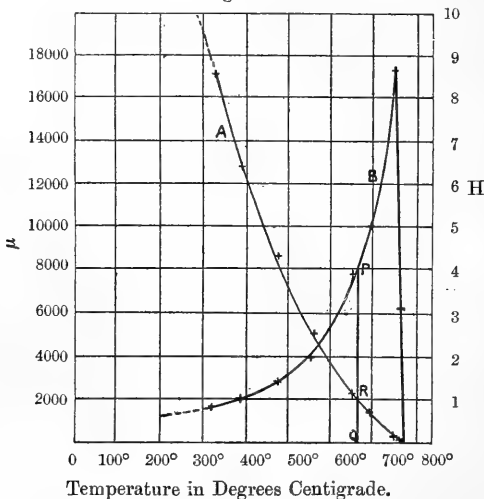

Fig. 5 is drawn to show the maximum permeability and the temperature at which it occurs for different magnetizing forces. In this figure the ordinates to the curves marked A and B represent the magnetizing force and maximum permeability respectively, and the abscissæ the temperature at which the permeability begins to fall.

To make this clear, let us consider the case of a magnetic force of 1 c.g.s. represented by RQ, the maximum permeability obtained with this field is given by the ordinate PQ, and is reached at a temperature represented by OQ. The scales of magnetic force and permeability are given on the right and left of the figure respectively.

We have seen that the successive stages of the magnetizing process are brought on with values of the magnetic force

depending upon the temperature; with very weak fields the second stage is not reached until the temperature is between 600° C. and 700° C., and then the permeability increases with great rapidity. Under a magnetizing force of such a strength that the second stage is just entered upon while the metal is cold, the rate of increase in permeability as the temperature is raised is comparatively slow. From this it appears that the effect of heat in hastening the transition from stage to stage is greater at high than at low temperatures.

Curves showing the relation between permeability and magnetic force, at different temperatures, were drawn with a view to ascertain the rate of transition as the temperature is raised.

Table I. (p. 12) gives the results obtained while the temperature was kept as nearly constant as was practicable during each set of readings.

These results are shown graphically in fig. 6; the scale of magnetic force is different for each curve, being regulated so that the maximum permeability occurs at the same distance along the horizontal axis in each case. The ordinates for the curves are drawn to the same scale except for a temperature of 735° C.: in this case the scale is reduced to $\frac{5}{8}$ for convenience in plotting. It will be seen from the figure that the curves are very similar to one another, and it will be found on reducing the ordinates in a suitable ratio for each temperature that the curves practically coincide.

The experiments were repeated several times, it being found that the kicks in the galvanometer with extremely small forces giving the first stage of the magnetizing process for the higher temperatures were in some experiments slightly larger than those from which the permeabilities given were calculated. This was attributed to the demagnetizing process not entirely wiping out all the effects of previous magnetism, the residual effect being noticeable only at high temperatures. In each case, however, as the second stage was entered upon, the corresponding kicks in each series of readings for the same temperature were practically identical.

Representing the results of experiment as in the figure, we see clearly that the effect of heating is to bring on the successive stages of the magnetizing process with values of the magnetic force depending upon the temperature.

The relation between temperature and magnetizing force in hastening the transition from stage to stage may be ascertained by observing the force necessary to bring on any definite point in the process of magnetization for different temperatures. For this purpose the point at which the

TABLE I.

	Magnetic Force (H).	Permeability (μ).		Magnetic Force (H).	Permeability (μ).
Temperature 15° C.	0.172	461	Temperature before experiment 258° C. Temperature after experiment 261° C.	0.086	488
	0.344	543		0.172	596
	0.43	630		0.344	814
	0.69	814		0.43	933
	1.075	1299		0.69	1315
	1.72	3084		1.075	2788
	1.935	3245		1.29	3509
	2.15	3273		1.72	3931
	2.58	3231		1.935	3870
	3.01	3129		2.15	3827
	4.30	2606		2.58	3609
	5.16	2349		3.44	3147
	6.45	1969		4.30	2719
8.60	1581	6.45	1980		
12.90	1124	8.60	1536		
Temperature before experiment 366° C. Temperature after experiment 368° C.	0.086	653	Temperature before experiment 481° C. Temperature after experiment 483° C.	0.0285	491
	0.172	759		0.086	922
	0.344	1004		0.172	1085
	0.43	1150		0.344	1628
	0.69	2228		0.43	1910
	1.075	4320		0.69	4208
	1.505	5078		1.075	5743
	1.935	4588		1.505	5467
	2.58	3986		1.935	4811
	3.44	3304		2.58	4070
	4.30	2769		3.44	3273
	5.805	2182		4.30	2744
	6.45	1988		5.805	2109
8.60	1561	6.45	1930		
Temperature before experiment 592° C. Temperature after experiment 592° C.	0.0285	819	Temperature before experiment 735° C. Temperature after experiment 735° C.	0.0285	2620
	0.086	1356		0.0568	3782
	0.172	1790		0.086	5101
	0.344	3580		0.129	9241
	0.43	6150		0.172	14852
	0.69	8204		0.194	15660
	0.86	7931		0.215	16000
	1.075	7250		0.258	15710
	1.29	6504		0.344	14442
	1.505	5898		0.43	12989
	1.935	4979		0.69	9315
	2.58	3944		1.075	6300
	3.44	3084		2.58	2735
4.30	2593				
6.45	1863				

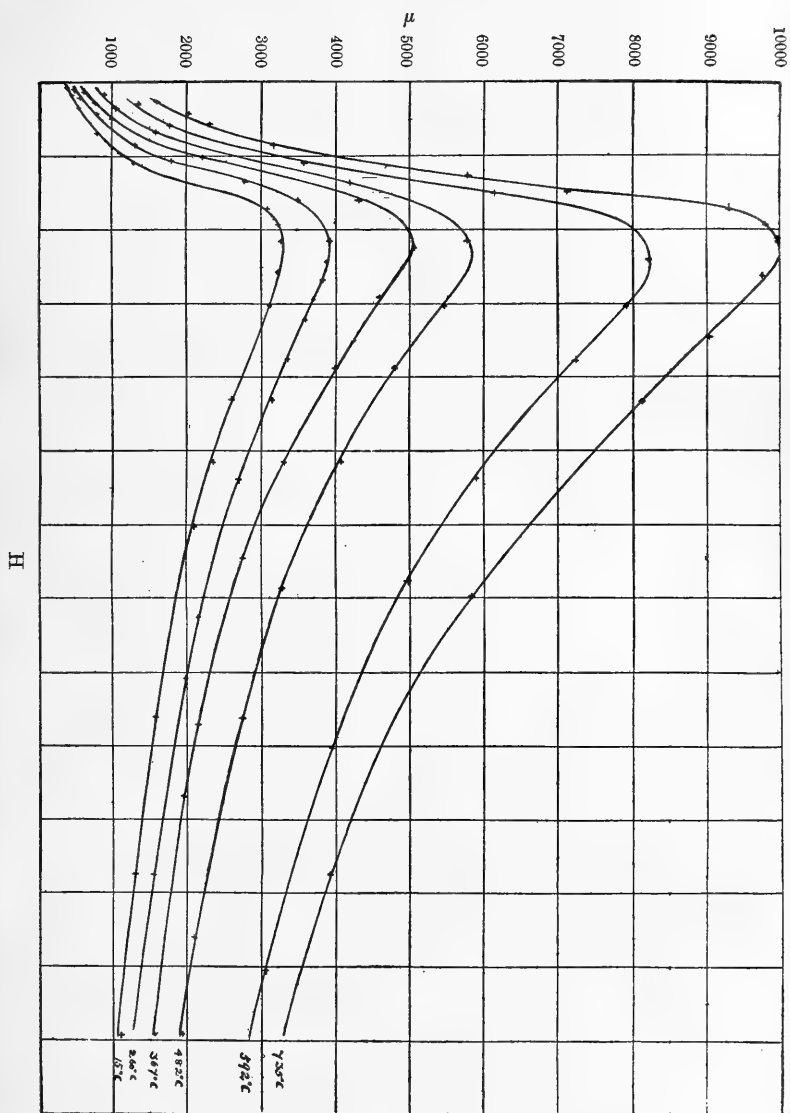
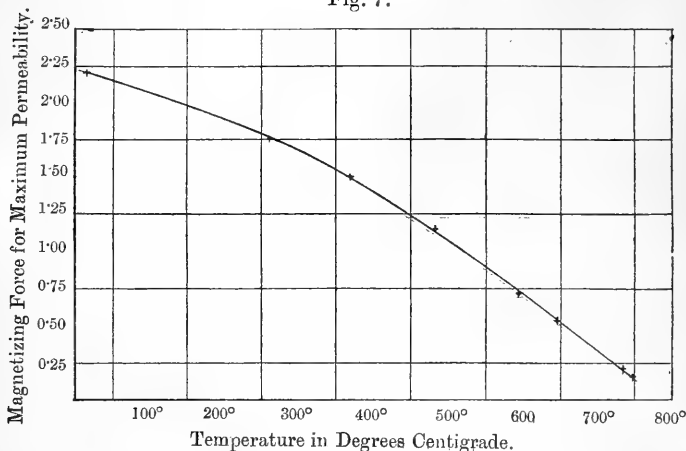

Fig. 6.—Wrought Iron Ring.

maximum permeability occurs has been taken, and the results shown graphically in fig. 7, where the ordinates to the curve measure the magnetizing forces giving the maximum permeability and the abscissæ the corresponding temperatures.

The curve in the figure gives a measure of how much earlier in the magnetizing process the successive stages are brought on by heating to any temperature; and it will be seen that the rate of transition from stage to stage increases with the temperature.

Fig. 7.



It has been shown above that the rise in permeability as the second stage is entered upon becomes more rapid as the magnetizing force is reduced; under a force of 1.075 c.g.s. (fig. 3) the permeability increases comparatively gradually as the temperature is raised; while with a force of 0.172 c.g.s. (fig. 4) the permeability rises very rapidly when the second stage is brought on. This is explained by the rate of transition from stage to stage being much greater at high than at low temperatures; in the former case the second stage is just entered upon while the ring is cold, while under the smaller magnetizing force the temperature necessary to bring on this stage is about 650° C.

Tungsten Alloy.

In the case of iron and highly permeable substances the first and second stages of the magnetizing process extend over a comparatively small range of magnetic force, and the passage from one stage to the other at high temperatures

can only be examined under extremely weak fields. This introduces a large percentage of possible error in estimating the permeability, the kicks in the galvanometer being very small.

It was thought that the effect of temperature in hastening the transition from stage to stage could be more satisfactorily examined in the case of alloys of iron giving a magnetization-curve the successive stages of which extend over a greater range of magnetic force.

Various investigations on the influence of elements on the magnetic properties of iron have shown that the presence of tungsten or chromium considerably lessens the permeability, the second stage of the magnetizing process not being entered upon until the magnetic force is fairly high.

Experiments of the same nature as those described above were made on an alloy containing 4.5 per cent. tungsten. The dimensions of the ring were as shown :—

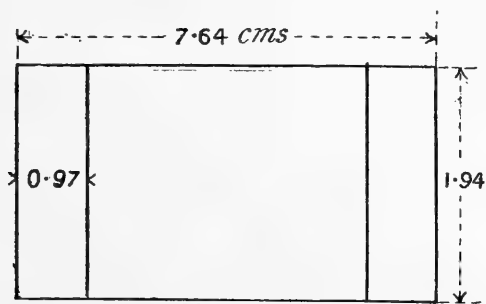

The values obtained for the induction with the corresponding magnetic forces at the ordinary temperature of the room were:—

Mag. Force...	0.40	1.63	4.89	7.34	8.97	10.60	13.76	16.72	18.76	24.4		
Ind. per } sq. cm. }	...	45	188	662	1169	2075	3973	8742	10799	11570	12534	13113

These results are shown plotted in fig. 8, together with the curve for the specimen of wrought iron described above.

It will be seen from the figure that for the tungsten alloy the permeability does not increase appreciably until the field is increased beyond about 7 C.G.S., and the point in the second stage of the magnetizing process giving the maximum permeability is only brought on when the field has reached a value of about 15 C.G.S.

As in the preceding case the temperature was kept as constant as was possible while the magnetic force was varied and

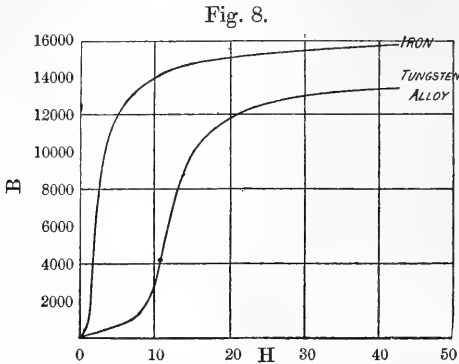

the observations repeated several times with reversed direction of magnetizing currents. For most of the temperatures given the whole set of readings were repeated.

It has been mentioned above that the process of "demagnetizing by reversals" does not appear entirely to wipe out all the effects of previous magnetization, although the effect of residual magnetism is noticeable under extremely small magnetic forces only at very high temperatures when the metal is in a critical state. With the tungsten alloy this residual effect could not be detected, even at the highest temperature.

Fig. 9 shows the permeability-temperature curves for different magnetizing forces, plotted from the following data:—

Temperature in Degrees C.	μ for $H=14\cdot885$. (Curve I.)	μ for $H=8\cdot156$. (Curve II.)	μ for $H=4\cdot078$. (Curve III.)	μ for $H=2\cdot039$. (Curve IV.)
15	647	176	130	117
266	686	557	168	140
370	660	847	292	219
468	647	987	649	304
543	622	1028	1396	693
591	609	1028	1615	996
632	557	942	1645	1775
640	513	887	1535	...
649	442	788	1436	2121
655	1386	2143
660	115	168	227	308

It will be seen from the figure that the general form of the curves resemble those given for iron, but the corresponding

Fig. 9.

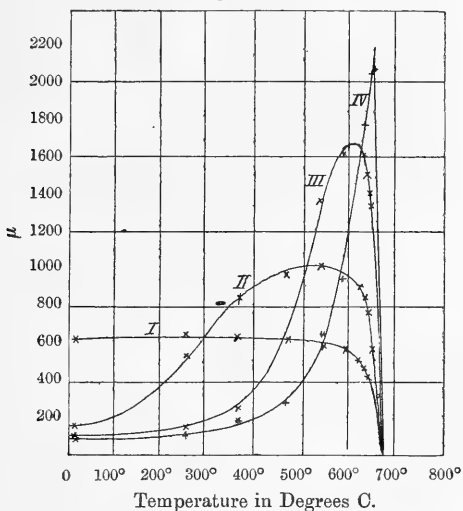

magnetic forces are much higher in the case of the tungsten alloy.

The curves given in the figure show more clearly than was possible with iron the effect of heat in hastening the transition from stage to stage of the magnetizing process. Under a magnetic force of about 15 c.g.s. the third stage is just entered upon at the ordinary temperature, and heating has very little effect on the permeability until a temperature of about 550° C. is passed, then the permeability falls.

It will be seen that, unlike the case for iron, the rate of increase in permeability as the second stage is brought on is practically the same for all magnetizing forces. This appears to indicate that the rate of transition from one to the other is independent of the temperature, because under a force of 8.156 c.g.s. the second stage is brought on at a comparatively low temperature, and as the force is reduced the temperature necessary to bring on this stage increases.

The maximum permeability obtained in each case, and the temperature at which it occurs, increases as the magnetic force is reduced, until the permeability reaches a value of about 2200 at a temperature of 650° C. with a force of about 2.04 c.g.s. On reducing the magnetizing force below this value, the maximum permeability obtained in each case decreases.

The following results were obtained with a magnetic force of about 0·4 c.g.s. :—

Temp. in } deg. C. }	15°	266°	370°	468°	543°	591°	632°	640°	649°	655°	660°
μ	111	137	188	256	470	491	735	769	994	1026	684

It was found, however, just as in the case of iron, that the permeability increases considerably as the temperature becomes rather high, even under extremely small magnetic forces.

Observations were taken at different temperatures as the ring was cooled; the magnetic quality returned as rapidly as it disappeared when the temperature had fallen about 20° C. below the critical temperature, and for each magnetizing force the curves showing the relation between permeability and temperature corresponding to heating and cooling were found to be very similar to one another.

Fig. 10 (p. 20) gives the permeability-magnetic force curves for different temperatures plotted from the data given in Table II., the scale of ordinates being the same for each curve; but the scale of abscissæ in each case is regulated so that the point of maximum permeability occurs at the same distance along the horizontal axis.

TABLE II.

	Magnetic Force (H).	Permeability (μ).		Magnetic Force (H).	Permeability (μ).
Temperature 15° C.	0·816	111	Temperature before experiment 370° C. Temperature after experiment 370° C.	0·41	188
	2·45	119		1·63	213
	4·08	130		2·45	233
	5·71	140		3·26	243
	7·34	160		4·08	292
	8·97	231		4·89	361
	11·42	498		5·71	526
	13·76	635		6·52	697
	14·88	647		7·34	787
	16·72	646		8·16	847
	18·76	611		9·79	847
	24·47	512		11·42	785
	40·78	322		12·23	756
	57·01	234		16·31	621
		20·39	511		
		24·47	434		

	Magnetic Force (H).	Permeability (μ).		Magnetic Force (H).	Permeability (μ).
Temperature before experiment 468° C.	0.41	256	Temperature before experiment 589° C.	0.16	491
	0.816	256		0.33	491
	1.22	262		0.65	513
	1.63	282		0.816	538
	2.04	304		1.22	593
	2.45	343		1.63	676
	3.26	433		2.04	996
	4.08	649		2.45	1245
	4.89	895		2.85	1538
	5.71	1054		3.26	1645
Temperature after experiment 468° C.	6.52	1047	Temperature after experiment 593° C.	4.08	1615
	7.34	1019		4.73	1513
	8.16	987		5.71	1353
	9.79	887		6.60	1211
	12.23	756		7.34	1130
	16.31	603		8.97	946
	22.43	453		12.23	725
				16.31	562
Temperature before experiment 630° C.	0.082	727	Temperature before experiment 649° C.	0.082	940
	0.41	735		0.163	940
	0.816	838		0.41	994
	1.22	1010		0.816	1137
	1.47	1203		1.22	1479
	1.79	1501		1.47	1774
	2.04	1775		1.79	2067
	2.45	1911		2.04	2121
	2.65	1917		2.45	2044
	2.85	1908		2.65	1979
Temperature after experiment 634° C.	3.26	1844	Temperature after experiment 649° C.	3.26	1719
	4.08	1645		4.08	1436
	4.89	1437		4.89	1229
	7.34	1030		7.34	864
	12.23	665			

In the case of iron (fig. 6) it was seen that the curves corresponding to different temperatures could be made to practically coincide by plotting to suitable scales; this is not the case with the tungsten alloy.

It will be seen from fig. 10 that heating has a much greater effect on the permeability during the first part of the process of magnetization than it has under stronger magnetic forces. The initial permeability when the metal is cold is slightly above 100, while at a temperature of 655° C. it is 1026; the maximum permeabilities obtained at the same temperatures were about 650 and 2140 respectively.

Fig. 10.—Tungsten Alloy.

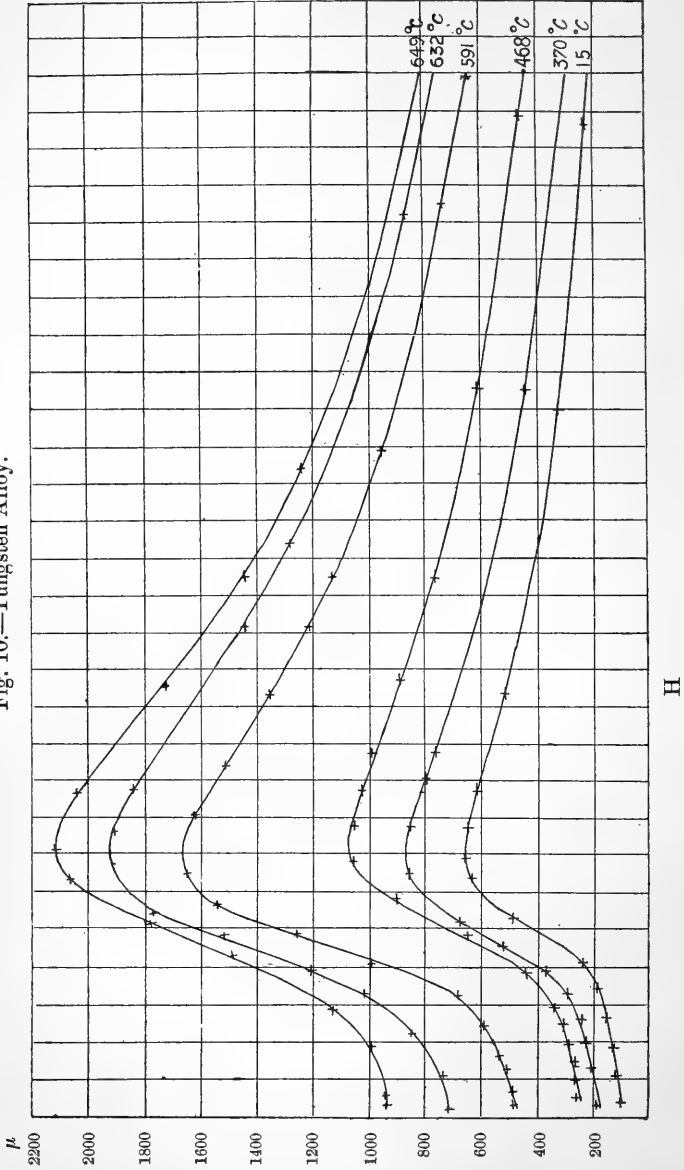

The figure also shows that at a temperature as high as 649° C. the permeability remains practically constant until the magnetic force is increased beyond about 0.4 c.g.s.

At a temperature of 655° C., when the metal is just about to enter the critical condition, the values of the permeability for different magnetizing forces were:—

Mag. Force ...	0.082	0.33	0.65	0.98	1.47	1.79	2.45	3.26	4.89	6.52
Permeability...	1026	1026	1134	1353	1985	2141	2044	1645	1188	922

This shows that the second stage of the magnetizing process is not brought on until the magnetic force is about 0.4 c.g.s. With weaker fields than this the effect of temperature in hastening the transition from one stage to the other is unable to bring on the second stage before the critical condition is reached and the magnetic quality lost.

The values of the permeability at different temperatures for a magnetic force of about 0.4 c.g.s. are given above, from which it will be seen that the permeability increases more than ninefold, although the second stage is not entered upon.

Fig. 11.

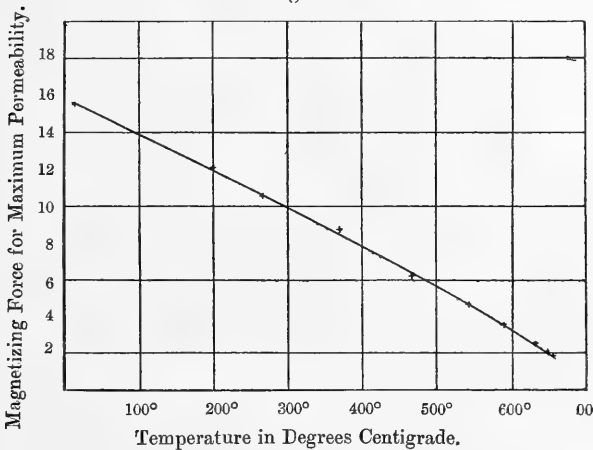

Fig. 11 is drawn to show the magnetizing force giving the maximum permeability at different temperatures. It will be seen that the points lie very nearly on a straight line, showing that the rate of transition from stage to stage with respect to temperature is fairly uniform.

Aluminium Alloy.

Investigations on the magnetic behaviour of alloys of iron have shown that the influence of aluminium is of an entirely different nature to that of most other elements.

Perhaps the most striking difference is seen between the effects of chromium or tungsten and aluminium.

The effect on the magnetic properties of iron of adding even a small percentage of tungsten is to increase considerably both the retentivity and coercive force, while the addition of a small percentage of aluminium has just the opposite effect. The maximum magnetization in each case is fairly high, but the permeability for the tungsten alloy is very small, while for the aluminium alloy it compares very favourably with that of the best iron.

From these considerations it appeared desirable to investigate the effect of heat on the magnetic properties of an aluminium alloy.

Richardson* has examined the effect of temperature on certain aluminium alloys, and drawn curves showing the change in induction with rise of temperature for different magnetizing forces.

The results of experiment given for an alloy containing 3.64 per cent. aluminium show that at the ordinary temperature the permeability is low, and, upon heating, the induction increases, reaching a maximum at a temperature of about 380° C.; the permeability decreases with rise of temperature near the critical point until a minimum value is reached, when further heating but slightly affects the permeability.

Other investigations † on the influence of elements on the magnetic properties of iron have shown that the addition of between 2 per cent. and 3 per cent. of aluminium has very little effect on the maximum induction, and that the permeability for low magnetizing forces is even higher than that of a good specimen of iron. It is also shown that when the percentage of aluminium is increased to 5.5 per cent. the maximum induction is fairly high, and the permeability for weak forces only slightly affected.

Experiments similar to those described above were made on an aluminium alloy of the following composition. The analysis

* *Phil. Mag.* January 1900, pp. 121-154.

† Barrett, Brown and Hadfield: "The Electrical Conductivity and Magnetic Permeability of various Alloys of Iron," *Trans. Roy. Dublin Soc.* vol. vii. Jan. 1900, p. 116.

was kindly furnished me by Mr. Clifford, A.R.C.Sc.I. :—

Al	C	Si	P.
2·60	0·15	0·17	0·13

The dimensions of the ring were as shown:—

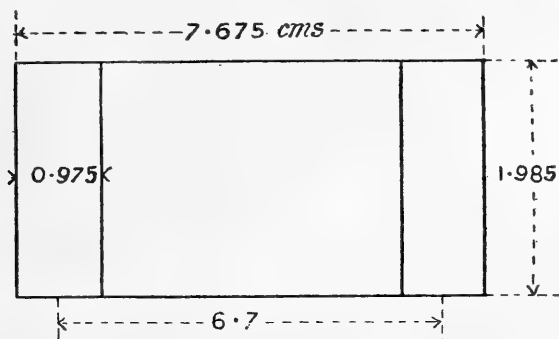

The values of the induction for different magnetic forces were first obtained at the ordinary temperature of the room, with the following results:—

Mag. Force...	0·085	0·25	0·64	0·85	1·06	1·70	2·12	3·39	5·3	9·33	13·57	
Ind. per sq. cm. }	...	28	129	670	1185	1931	4037	5092	7437	9201	11118	12077

The susceptibility with respect to magnetic forces below about 1·2 C.G.S. is even greater than in the case of the iron specimen described above*. The second stage of the magnetizing process is brought on when the field is about 0·8 C.G.S., and the maximum permeability obtained with a force of about 2 C.G.S., while for iron the corresponding values of the magnetic force were shown to be about 1 C.G.S. and 2·2 C.G.S. respectively.

The ring was examined in successive experiments while the temperature was kept constant, and after each experiment demagnetized by reversals.

The values for the permeability in terms of magnetic force for different temperatures are given in Table III.

* The absence of this remarkable magnetic quality of aluminium steels in the alloy referred to above containing 3·64 per cent. aluminium is apparently due to the influence of the large percentage of other elements present. The effect of any particular element on the magnetic properties of iron varies very considerably according to the other elements present and the percentage of these elements.

TABLE III.

	Magnetic Force (H).	Permeability (μ).		Magnetic Force (H).	Permeability (μ).
Temperature 15° C.	0.085	327	Temperature before experiment 360° C. Temperature after experiment 360° C.	0.085	581
	0.25	505		0.17	695
	0.42	735		0.25	1035
	0.64	1054		0.34	1573
	1.06	1822		0.42	2277
	1.27	2105		0.64	4140
	1.70	2381		0.85	4813
	2.12	2402		1.06	4804
	2.54	2351		1.27	4512
	3.39	2192		1.70	4177
	4.24	1944		2.12	3630
	6.36	1537		2.54	3466
	9.33	1192		3.39	2910
	13.57	890		4.24	2532
			6.36	1838	
Temperature before experiment 487° C. Temperature after experiment 491° C.	0.085	817	Temperature before experiment 632° C. Temperature after experiment 632° C.	0.02	3269
	0.17	1185		0.04	3269
	0.25	1444		0.085	3841
	0.34	1879		0.127	5790
	0.42	2174		0.17	7263
	0.64	2760		0.21	8507
	0.76	2990		0.25	8778
	0.93	3058		0.30	8576
	1.15	3028		0.42	8073
	1.40	2917		0.51	7763
	1.70	2764		0.64	6991
	2.12	2479		0.76	6567
	2.54	2319		1.02	5567
	3.39	2026		1.27	4925
4.66	1705	1.70	4099		
6.36	1401				
Temperature before experiment 660° C. Temperature after experiment 660° C.	0.042	4413	Temperature before experiment 686° C. Temperature after experiment 686° C.	0.032	7845
	0.085	7110		0.039	9123
	0.127	10696		0.064	13947
	0.17	12420		0.078	15933
	0.21	13041		0.10	17251
	0.30	12494		0.155	16132
	0.42	10486		0.21	12870
	0.51	9691		0.25	10695
	0.64	8389		0.34	8151
	0.85	6578		0.42	6624
	1.27	4639		0.85	3415
	1.70	3504		2.12	1469
	2.12	2823			

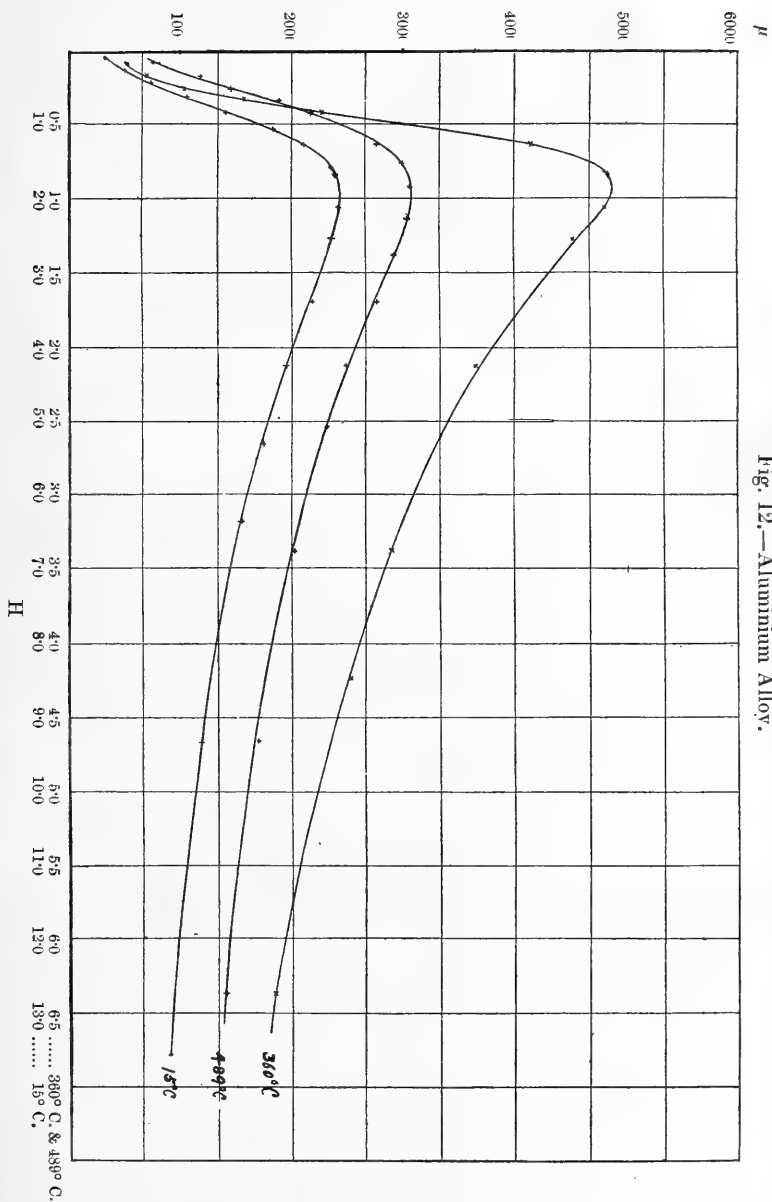
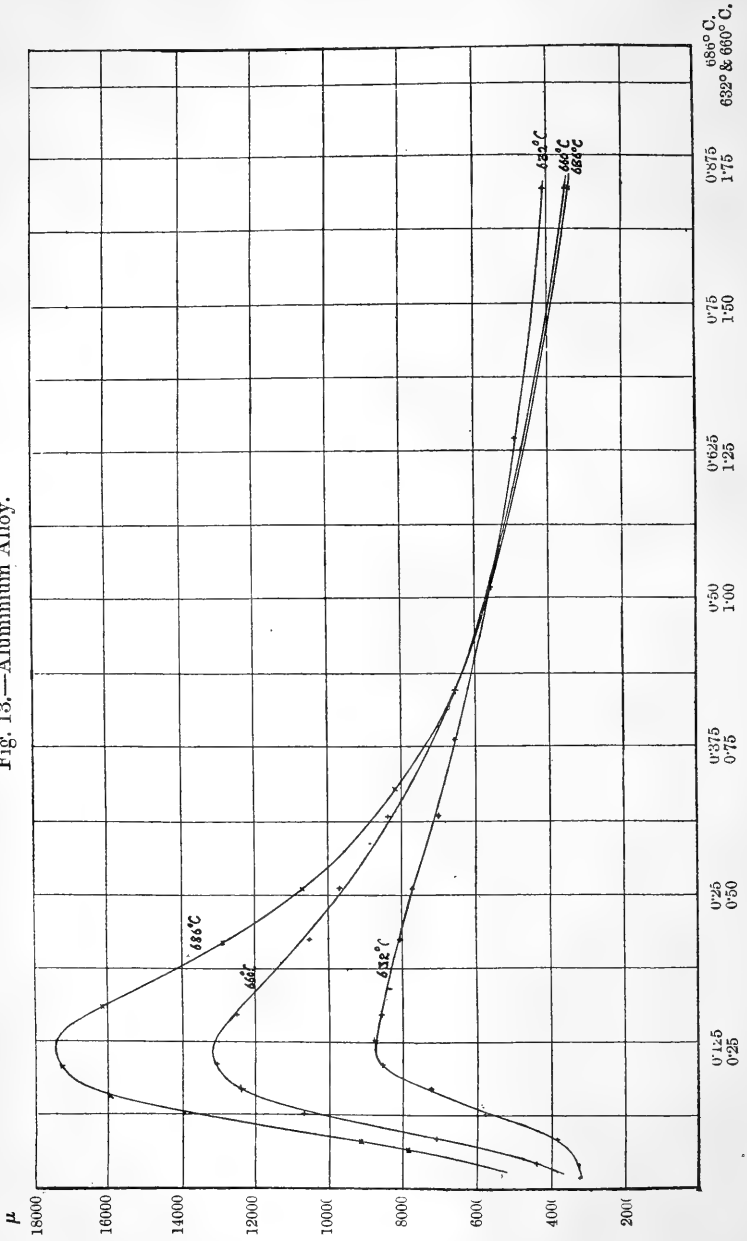

Fig. 12.—Aluminium Alloy.

Fig. 13.—Aluminium Alloy.



These results are shown graphically in figs. 12 and 13: the scale of magnetic force for each curve is so chosen that the point giving the maximum permeability in each case occurs at the same distance along the horizontal axis.

It has been seen from the corresponding curves for each of the preceding specimens that the permeability at any stage of the process of magnetization has, in a general way, increased with the temperature.

This, however, is not the case with the aluminium alloy.

Referring to fig. 12, it will be seen that for magnetic forces above about 0.4 C.G.S. the specimen is much more susceptible to magnetization at a temperature of 360° C. than it is when the temperature has risen to 489° C.

It is also seen that at these particular temperatures the successive stages of the magnetizing process are brought on with practically the same magnetic forces. This is also the case for temperatures of 632° C. and 660° C.

Corresponding curves for higher temperatures are shown in fig. 13.

As the temperature is raised beyond 632° C. the permeability for weak magnetic forces rapidly increases, and reaches a value of about 17250, the maximum obtainable with a force of about 0.125 C.G.S., at a temperature of 686° C.

The values of the permeability at different temperatures under a magnetic force of 0.127 C.G.S. were:—

Temp. in deg. C. } 15°	218°	360°	428°	489°	527°	609°	632°	660°	686°	
μ	381	490	599	735	1035	1689	3977	5790	10696	17250

Plotting these results, we get a curve very similar to that obtained for iron with the corresponding critical force of 0.172 C.G.S., shown in fig. 4 (p. 9).

As the magnetizing force is reduced beyond this critical value, the maximum permeability obtained in each case decreases.

It will be seen that the magnetic force giving the maximum obtainable permeability for the aluminium alloy is smaller than the corresponding force for the iron specimen.

At a temperature of 695° C. the alloy is practically non-magnetic. It was found, however, that the effects of previous magnetization were not entirely got rid of by heating the ring beyond this temperature.

Observations were taken with different magnetizing forces as the ring cooled. The magnetic quality returns as rapidly as it disappeared at a temperature slightly below the critical point, and for each magnetizing force the permeability reaches the same maximum value as that obtained during heating.

Representing the results of experiment given in Table III. by plotting permeability with respect to temperature for fairly strong fields, the changes in the permeability shown in figs. 12 and 13 are seen to take place comparatively suddenly, the curves showing points of maximum permeability at temperatures about 400° C. and 590° C.

The relative values of the permeability at these maximum points vary with the field. For magnetizing forces below about 1 c.g.s. the maximum permeability occurs at temperatures near the critical point, as in the case of iron. Under forces between about 1 c.g.s. and 2.6 c.g.s. the maximum permeability occurs at the higher maximum point, that is, at about 590° C., and with magnetizing forces above 2.6 c.g.s. the maximum permeability is reached at about 400° C.

This lower maximum point agrees very closely with that found by Richardson*.

5 per cent. Nickel Alloy.

Various investigations have shown that steels containing certain percentages of nickel possess remarkable physical properties. Hopkinson† investigated the effect of temperature on the magnetic properties of a steel containing 5 per cent. nickel, and gave curves showing the change in induction with respect to temperature for different magnetizing forces. At the ordinary temperature of the room the maximum magnetization of this specimen was greater than that of wrought iron.

Experiments of the same nature as those described above were made on a steel containing about 5 per cent. nickel to see the effect of temperature on the permeability in each of the stages of the magnetizing process, and to ascertain the relation between temperature and magnetic force in bringing on the successive stages.

The dimensions of the ring were as shown:—

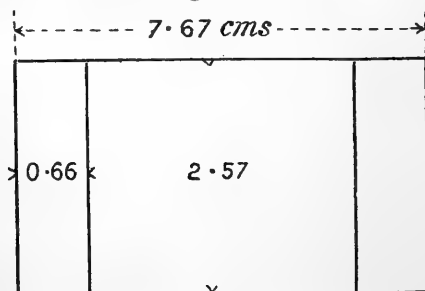

* Phil. Mag. Jan. 1900, p. 137.

† Proc. Roy. Soc. vol. xlviii. p. 6 (1890).

The following values of induction in terms of magnetic force were obtained at the ordinary temperature of the room, where H represents magnetic force and B induction :—

H.	B.	H.	B.	H.	B.	H.	B.
0.155	31	3.10	1270	6.21	7020	11.64	11737
0.78	186	3.88	2394	7.76	9069	15.52	13017
2.33	758	5.43	5620	9.31	10670	20.18	13657

As in the preceding experiments, the temperature was kept as constant as was possible, and the magnetic force varied.

Table IV. gives the values of the permeability in terms of magnetic force for different temperatures. These results are plotted in fig. 14, the scale of abscissæ for each curve being regulated as in the corresponding curves for each of the preceding specimens; the scale of ordinates is the same for each curve.

TABLE IV.

	Magnetic Force (H).	Permeability (μ).		Magnetic Force (H).	Permeability (μ).
Temperature 15° C.	0.155	199	Temperature before experiment 348° C. Temperature after experiment 350° C.	0.155	354
	0.39	219		0.39	359
	0.78	239		0.78	374
	1.55	274		1.55	469
	2.33	326		2.33	714
	3.10	409		2.72	882
	3.88	617		3.10	1070
	4.66	850		3.49	1232
	5.43	1034		3.88	1335
	6.21	1130		4.66	1411
	6.98	1168		5.43	1391
	7.76	1168		6.21	1348
	9.31	1146		6.98	1283
	11.64	1008		7.76	1210
	15.52	839		10.09	1036
	20.18	677		12.42	894
		15.52	770		

TABLE IV. (cont.).

	Magnetic Force (H).	Permeability (μ).		Magnetic Force (H).	Permeability (μ).
Temperature before experiment 465° C.	0.155	423	Temperature before experiment 526° C.	0.155	648
	0.39	458		0.39	717
	0.78	478		0.62	785
	1.164	532		0.93	897
	1.55	692		1.164	1091
	1.94	957		1.39	1329
	2.33	1322		1.55	1574
	2.72	1548		1.71	1808
	3.10	1669		1.94	2065
	3.49	1701		2.17	2249
	3.88	1693		2.33	2319
	4.66	1604		2.72	2352
	5.43	1524		3.10	2290
Temperature after experiment 465° C.	6.21	1421	Temperature after experiment 528° C.	3.88	2063
	6.98	1327		4.66	1875
	7.76	1241		6.98	1405
	10.09	1015		7.76	1292
	12.42	876			
Temperature before experiment 586° C.	0.155	997	Temperature before experiment 626° C.	0.078	1395
	0.39	1036		0.155	1395
	0.58	1156		0.39	1475
	0.78	1322		0.62	1619
	1.01	1744		0.78	1952
	1.164	2099		0.93	2414
	1.36	2627		1.164	3065
	1.55	2928		1.39	3286
	1.71	3163		1.55	3305
	1.94	3201		1.94	2922
	2.33	3093		2.33	2532
	3.10	2726		3.10	1986
	3.88	2365		3.88	1647
5.43	1807	5.43	1242		
7.76	1347	7.76	904		
Temperature before experiment 637° C.	0.078	1295	Temperature after experiment 637° C.	0.078	1295
	0.155	1295		0.155	1295
	0.233	1295		0.233	1295
	0.39	1396		0.39	1396
	0.62	1574		0.62	1574
	0.78	1826		0.78	1826
	0.93	2204		0.93	2204
	1.164	2603		1.164	2603
	1.32	2593		1.32	2593
	1.55	2424		1.55	2424
	1.94	2053		1.94	2053
	2.33	1784		2.33	1784
	3.88	1196		3.88	1196
5.43	917	5.43	917		
7.76	696	7.76	696		

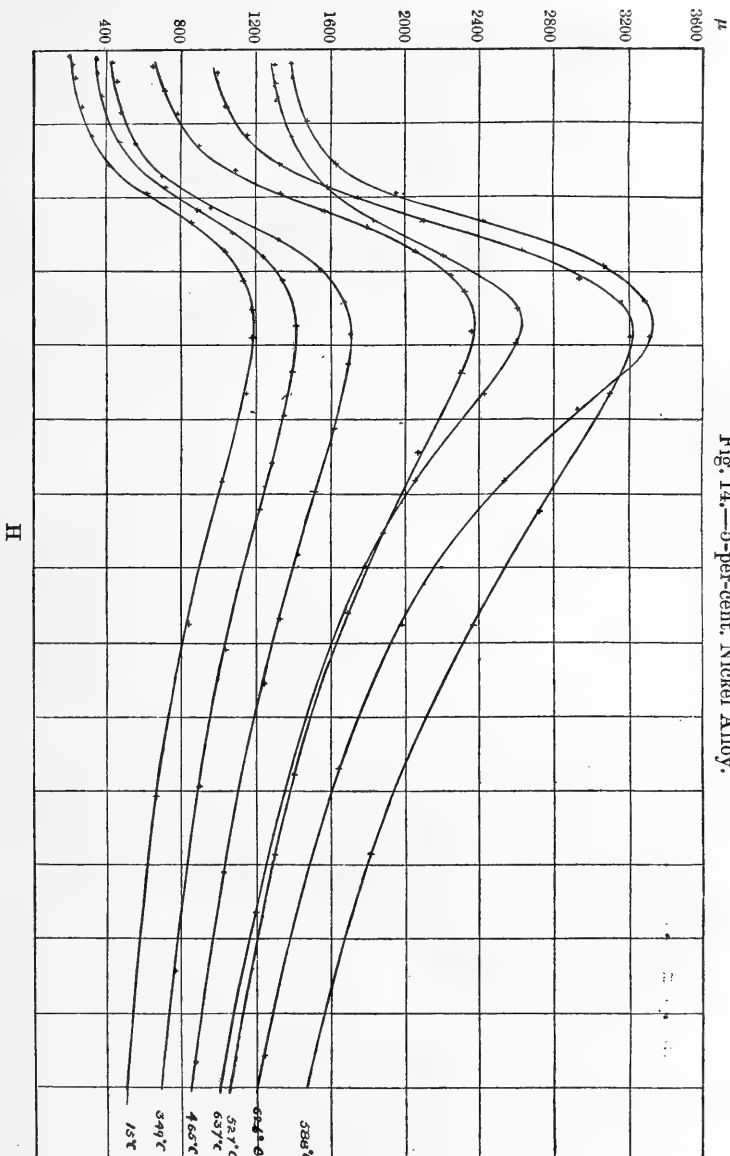

Fig. 14.—5-per-cent. Nickel Alloy.

With this specimen the maximum obtainable permeability is reached at a temperature of about 626°C . with a magnetic force of about 1.5 c.g.s. Increasing the temperature beyond this point the magnetic susceptibility decreases, until at about 700°C . the metal is practically non-magnetic.

The curve for a temperature of 637°C . is given in the figure, from which it will be seen that the permeability at any stage of the magnetizing process is less than that at the corresponding stage when the temperature is 626°C . This shows that with extremely weak fields the maximum permeability occurs at about 626°C ., and that, unlike each of the preceding specimens, the passage from the magnetic to the non-magnetic state is gradual, even under the smallest magnetizing force.

It is interesting to notice that the successive stages of the magnetizing process are quite distinguishable, even when the temperature is such that the metal is passing from the magnetic to the non-magnetic state.

On cooling, the magnetic quality appears at a temperature of about 620°C . The general form of the curves obtained by plotting permeability with respect to temperature for different magnetizing forces agrees satisfactorily with those given by Hopkinson*.

Fig. 15 is drawn to show the change in the value of the magnetic force giving the maximum permeability as the

Fig. 15.

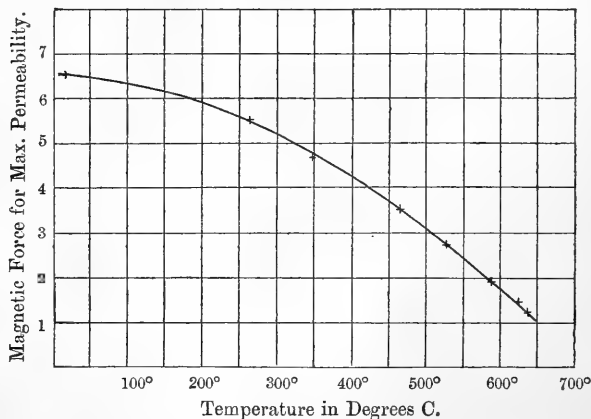

temperature is raised. It will be seen that this curve is very similar to the corresponding curve for iron given in fig. 7 (p. 14),

* Proc. Roy. Soc. vol. xlviii. p. 7 (1890).

and shows that the rate of transition from stage to stage of the magnetizing process as the temperature increases is much greater for high than for low temperatures.

Cr-Mn-C Alloy.

The results of experiments made previously at the ordinary temperature of the atmosphere on an alloy containing fairly large percentages of chromium, manganese, and carbon showed that unannealed the specimen was practically non-magnetic, while after heating to a temperature of about 1000° C., and allowing to cool very slowly, it was found to be strongly magnetic.

An alloy of very similar composition to the specimen referred to was obtained in the form of a ring, and the magnetic properties examined at different temperatures. The specimen contains about 9 per cent. Cr, 3 per cent. Mn, and 1 per cent. C. The dimensions of the ring were as shown:—

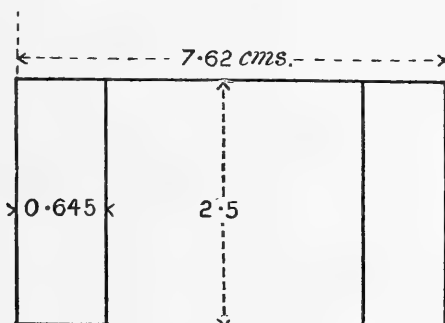

The following results of observations of induction in terms of magnetic force were obtained at the ordinary temperature:—

Mag. Force...	0.88	3.51	7.02	11.4	15.4	19.3	21.9	23.7	26.3	30.7	35.1	42.15
Ind. per sq. cm. } ...	40	167	382	781	1342	2833	4506	5356	6261	7400	8064	8823

In this case the second stage of the magnetizing process is not entered upon until the magnetic force is increased beyond about 16 C.G.S.

The ring was examined in successive experiments while the temperature was kept as nearly constant as was practicable, and after each experiment the specimen was demagnetized by reversals.

Table V. gives the values of the permeability in terms of magnetic force for different temperatures.

TABLE V.

	Magnetic Force (H).	Permeability (μ).		Magnetic Force (H).	Permeability (μ).
Temperature 15° C.	1.76	46	Temperature before experiment 245° C. Temperature after experiment 245° C.	1.76	67
	5.27	49		5.27	79
	8.78	57		8.78	103
	13.17	74		10.54	141
	17.56	109		13.17	231
	21.95	205		15.36	346
	23.71	226		17.56	360
	26.34	238		19.32	354
	30.73	241		21.95	335
	35.12	230		26.34	304
42.15	209	30.73	273		
			36.87	236	
Temperature before experiment 314° C. Temperature after experiment 316° C.	0.88	79	Temperature before experiment 482° C. Temperature after experiment 482° C.	0.176	185
	3.51	95		0.88	185
	5.27	105		2.63	238
	8.78	153		4.39	317
	12.73	364		7.02	549
	15.36	395		7.90	586
	17.56	383		8.78	604
	19.75	365		10.54	580
	21.95	346		13.17	511
	26.34	306		17.56	411
32.92	259	21.95	346		
38.63	228	26.34	298		
Temperature before experiment 607° C. Temperature after experiment 607° C.	0.176	278	Temperature before experiment 681° C. Temperature after experiment 681° C.	0.176	370
	1.76	347		0.88	445
	2.63	419		1.76	577
	4.39	611		2.20	652
	5.27	694		3.07	805
	6.15	712		3.51	824
	7.02	704		3.95	821
	7.90	660		4.39	798
	8.78	626		5.27	714
	10.98	519		6.15	645
13.17	454	8.78	494		
17.56	362				

The results are shown graphically in fig. 16, the scale of magnetic force for each curve being regulated so that the point giving the maximum permeability occurs at the same distance along the axis of force in each case.

It will be seen that as the temperature increases the first and second stages of the magnetizing process get less distinguishable, and when a temperature of 681° C. is reached there is practically no first stage at all.

Comparing these curves with the corresponding curves for

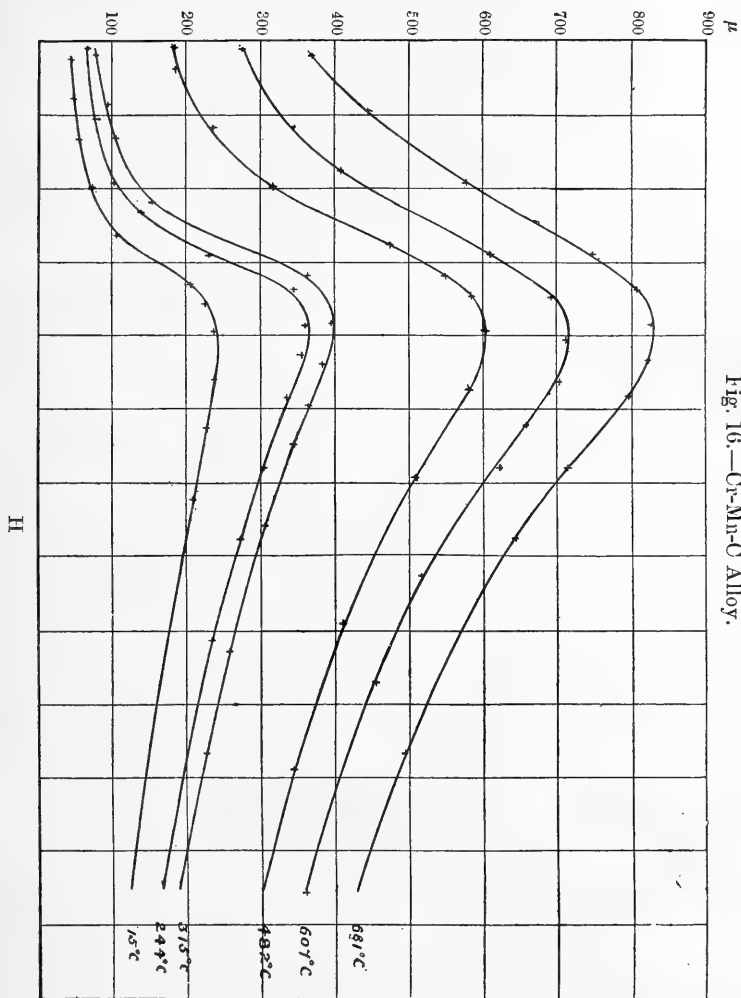

Fig. 16.—Cr-Mn-C Alloy.

the tungsten alloy given in fig. 10 (p. 20), we see that the effect of temperature on the first and second stages is very similar in each case; but in the Cr-Mn-C alloy the effect is more marked, the first stage entirely disappearing at high temperatures. This is all the more remarkable seeing that in the latter case the value of the magnetic force necessary to bring on the second stage at the ordinary temperature of the room is more than double that required in the case of the tungsten alloy.

The maximum permeability is obtained with a magnetizing force of about 3.5 c.g.s. at a temperature of 681° C., the value being slightly over 820. As the temperature is raised above 681° C. the initial permeability is increased, as in the case of the tungsten specimen, but the maximum permeability obtained in each case decreases.

At a temperature of 726° C. the alloy is practically non-magnetic.

On cooling, the magnetic quality does not return until the temperature has fallen to about 650° C.

The following values of the permeability in terms of magnetic force were obtained while the temperature fell from 645° C. to 640° C.

Magnetic Force 0.18 0.44 0.88 1.76 2.63 4.39 6.15 7.9

Permeability ... 324 371 417 487 684 821 688 632

It will be noticed that the permeability reaches practically

Fig. 17.

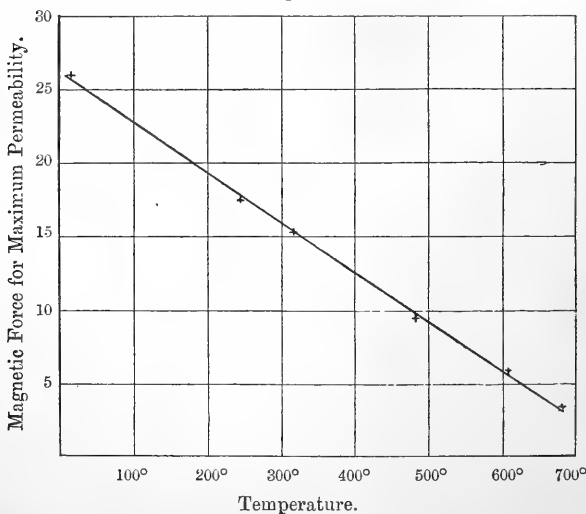

the same maximum value and is obtained with about the same magnetizing force as that given above.

Fig. 17 shows the magnetizing force giving the maximum permeability at different temperatures. It will be seen that, as in the case of the tungsten alloy, the points lie almost on a straight line.

I desire, in conclusion, to express my thanks to Prof. J. J. Thomson for many useful suggestions during the course of the investigation.

Cavendish Laboratory,
Cambridge.

II. *The Heat of Formation of Alloys.* By J. B. TAYLER,
B.Sc.(Vict.), University College, Liverpool.*

EXPERIMENTS have been made upon alloys of lead with tin, bismuth, and zinc, and of zinc with tin and mercury. The method employed, which determined the choice of alloys, consists in dissolving (*a*) the alloy, and (*b*) the corresponding mixture of metals, in mercury, and measuring the heat of solution in each case. Assuming that the solutions so obtained are identical, the difference between the heat of solution of the mixture and that of the alloy is the heat of formation of the latter. The method is thus not very different in principle from that employed by Dr. Galt†, and probably also that employed in an as yet unpublished research by Mr. Baker in the determination of the heat of formation of brass.

The calorimeter used is shown in the figure. Four were made, differing only in size and minor details. In the first two the inner vessel (*a* in the figure) was of such a size that 300 grammes of mercury could be used; the two later ones took 500 grammes. In all cases *a* was a tube of thin glass held in place in a larger and thicker tube (*b*) by an india-rubber ring. The outer tube could be similarly fitted into the bottle *c*. To reduce radiation the vessels were silvered, *a* on the outside, *b* and *c* on the inside. The calorimeter was closed by an indiarubber stopper which carried a small receptacle *d* also of glass. An elastic band projected about $\frac{1}{16}$ of an inch beyond the lower end of *d*, so forming a pad against which the wooden cone *h* could be pressed. The latter communicated by a stiff wire with the outside, and could be raised or lowered at will; when necessary, from a

* Communicated by the Physical Society: read May 11th, 1900.

† Brit. Assoc. Rep. 1898, pp. 787, 788, and B. A. Rep. 1899.

distance. The glass stirrer could likewise be worked, and the thermometer read, without going up to the calorimeter. These precautions were only taken in the later experiments.

Fig. 1.

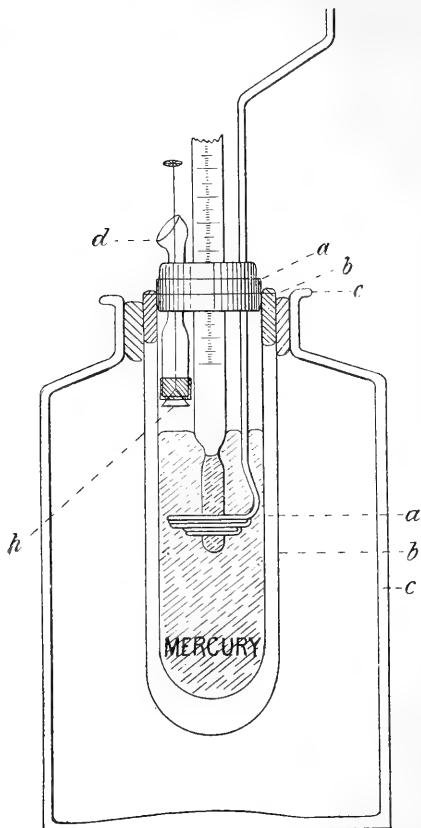

The thermometer used with the first two calorimeters was graduated in tenths, and could be read to hundredths of a degree. That used subsequently was graduated in hundredths, and could be read to the one-thousandth of a degree. (The results of the two sets of experiments can be distinguished by the water-value of the calorimeter.) The experiments were conducted in the Chemical department of the College, and no special precautions could be taken to keep the room at constant temperature; and the thermometer was sometimes subjected to changes two or three times as large as the one

to be measured, since the mercury had to be weighed in another room.

The water-values of the calorimeters were measured experimentally. This was done by running in mercury at 100°C. , the operations being in all other respects precisely the same as when a heat of solution was being determined. In each case the mean of five to ten experiments was taken.

The order of procedure was the following:—The mercury in which the metal or alloy was to be dissolved was weighed into the inner vessel of the calorimeter, and the thermometer and stirrer placed in position. The alloy (or metal) was then filed, and the filings weighed and introduced into the receiver *d*. After the lapse of about a quarter of an hour the stirrer was agitated (always by hand) and the temperature read at short time-intervals. Sufficient readings having been obtained for the radiation curve, the filings were allowed to drop on to the mercury by lowering *h*, and temperature readings were taken for the next 5 to 15 minutes. Solution was often complete in less than a minute, and rarely took more than $2\frac{1}{2}$ minutes.

The mercury was always purified before use by treatment with nitric acid. One-fifth of its volume of concentrated acid was poured on, and the mercury thoroughly agitated. The whole was left over-night, and the crust of nitrate broken off and removed as far as possible in the morning. The mercury was then washed with water, dried with calcium sulphate, and filtered through chamois leather. Moreover, each alloy and its corresponding mixture were always dissolved in mercury from the same batch, so that only the heat of solution, and not the heat of formation, could be affected by impurities. The metals were obtained from Kaulbaum; but some experiments with commercially pure zinc showed that small quantities of impurities did not appreciably affect the result. To make the alloys, it was found best to melt the metal of which the larger quantity was being used in a graphite crucible, and to drop the other in solid. All the metals used melt at a low temperature, and very little oxidation seems to have taken place. When a eutectic* alloy was wanted, the fluid mass was poured, after stirring, into a deep cylindrical mould maintained for some time a few degrees above the melting-point of the eutectic and then gradually cooled down. The line of demarcation between the eutectic and the upper layer was invariably sharp. The alloy A, in Table I., was formed by dissolving the requisite quantity of zinc in molten lead; B

* This is Dr. Guthrie's name for the alloy with the lowest melting-point.

TABLE I.

ALLOY.	SOLUTION OF ALLOY.				SOLUTION OF MIXTURE.				Heat of Formation of 1 grm. Alloy in Calories.
	Grammes used.	Water-value of Calorimeter in Grams.	Temp. fall, °C.	Heat of Solution per grm. in Calories.	Grammes used.	Water-value of Calorimeter in Grams.	Temp. fall, °C.	Heat of Solution per grm. in Calories.	
LEAD-ZINC.	2.26	18.9	1.06	8.9	1.293	18.4	0.988	14.1	-5.8
	1.308	18.3	0.557	7.8				14.1	
LEAD-ZINC.	0.6542	17.0	0.350	9.1	0.878	17.3	0.69	13.6	-3.5
	0.704	17.3	0.470	11.3	0.867	17.3	0.64	12.8	
	0.975	17.4	0.550	10.0	0.840	17.4	0.70	14.5	
				10.1				13.6	
LEAD-BISMUTH (Eutectic). Bismuth 44.4 p. c.	0.990	18.3	0.824	15.2	0.994	18.3	0.618	11.4	+3.8
LEAD-TIN ALLOYS.	1.8389	26.51	0.774	11.18	1.9377	26.70	0.949	13.79	-1.0
	2.1839	28.51	1.040	13.55	2.2335	28.24	1.072	13.55	
	0.9834	26.60	0.505	13.66					
	1.7555	28.21	0.759	12.20					
	1.1678	26.66	0.565	12.89				13.67	

LEAD-TIN ALLOYS.											
Lead-Tin. Tin 5.1 p. c.	1.3416	26.62	0.713	14.1	1.3069	26.56	0.714	13.9	-1.1	}	}
	1.6543	28.28	0.662	11.3	1.4269	28.27	0.712	14.1			
	1.4686	28.47	0.687	13.3				14.0			
Lead-Tin. Tin 5.0 p. c.	1.153	18.4	0.995	15.9	1.153	18.4	1.088	16.6	-1.1	}	}
	1.130	18.4	0.920	15.0	1.150	18.4	1.036	16.6			
	1.153	18.4	0.975	15.6				16.6			
Lead-Tin. Tin 21.0 p. c.	0.947	26.67	0.567	16.0	1.8379	28.33	1.140	17.59	-0.8	}	}
	1.8377	28.41	1.049	16.2	1.0195	26.67	0.619	16.19			
					1.8669	28.33	1.077	16.34			
Lead-Tin (Eutectic) Tin 61.8 p. c.	1.00	18.3	1.47	26.9	1.019	18.25	1.39	24.9	+1.9	}	}
	0.995	18.4	1.45	26.8				24.9			
				26.8	0.660	18.4	0.97	27.0			
Lead-Tin. Tin 90.0 p. c.	0.662	18.4	1.11	30.9					+3.9	}	}
	0.972	18.4	1.54	29.2	0.985	18.4	1.19	22.2			
	0.934	18.4	1.61	31.7	0.936	18.4	1.34	26.4			
Tin-Zinc (Eutectic). Zinc 8.3 p. c.				30.4				24.3	+6.1	}	}
Zinc-Mercury. Zinc 8.7 p. c.	2.611	18.4	0.700	4.93		Pure Zinc.		3.15	+1.8	}	}
					0.479	18.4	0.940	36.1			
Zinc-Mercury. Zinc 25.9 p. c.	1.888	18.4	1.106	10.8				9.35	+1.5	}	}
	1.888	18.4	1.370	13.4				9.35			

* See text.

was a true eutectic. Of the alloys of lead and tin, those containing 2.0 and 5.1 per cent. of the latter were made by adding lead to the 21 per cent. alloy; as it was thought that the more nearly equal the two portions melted together, the smaller would the percentage error be. In no case was an analysis made. In order, as far as possible, to ensure homogeneity in the alloys, they were kept stirred until they had nearly cooled down to the solidifying point, and were then poured out into shallow carbon moulds. Both from their behaviour under the file and from their heat of solution, the alloys seem to have been homogeneous, with the exception of the amalgam of zinc containing 25.9 per cent. of that metal. This separated into two portions, one of which was lighter and softer than the other. The former is distinguished as α , and the latter as β , in the table of results.

The alloys first experimented upon contained their constituents in equivalent proportions, and the heats of formation were found to be small in comparison with those found for brass by Dr. Galt and Mr. Baker. Since the alloys concerned belonged to the class which Matthiessen regarded as solutions, and since they were made at comparatively low temperatures, it was thought that definite chemical combination had only taken place between a small percentage of the atoms present, and that more reliable results would be obtained by dissolving small quantities of one metal in a large excess of others. The heat of formation *per gramme of alloy* was found to be higher in the cases tried; and the heat of formation of the gramme-molecular weight of *compound*, supposing that the whole of the metal present in small quantity had entered into chemical combination by the exercise of its normal valency, was, of course, immensely greater. The latter is the quantity it was desired to be sure about, the object of the work being to determine the order of magnitude of the chemical forces which effect the combination of metals. The second column of Table II. contains the figures calculated from those in the first column on the above supposition.

Incidentally it appears that the so-called "mechanical mixtures" (so Matthiessen regarded alloys of lead and zinc) and "solutions" (lead and tin, zinc and tin) contain a small percentage of true compounds, and that eutectic alloys do not necessarily correspond to the greatest evolution of heat.

Throughout the work I have had the privilege of Prof. Lodge's advice and supervision, and my best thanks are also due to Drs. C. A. Kohn and T. L. Bailey for their kind advice upon several matters of detail.

TABLE II.

ALLOY.	Heat of Formation per gramme alloy in calories.	* Heat of Formation per gramme molec. weight of compound (see text) in calories.	Volts corresponding thereto.	Observed Volta Effect in volts.	Peltier E.M.F. in volts.
Lead-Zinc Eutectic. } Zinc 1·6 p. c.	-5·8	-23,800	·53	·210 (Ayrton & Perry)	·0308
Lead-Zinc. } Zinc 23·9 p. c.	-3·5	-960	·02	·31 (Pellat)	
Lead-Bismuth. } Lead 55·6 p. c.	+3·8	+1,400	·03	...	·017
Tin-Zinc Eutectic. } Zinc 8·3 p. c.	+6·1	+4,800	·10	·281 (A. & P.) ·35 (Pellat)	·0009
Lead-Tin.					
Tin 90 0 p. c.	+3·9	+8,100	·18	·099 (A. & P.)	·0000: Pellat by difference.
„ 61 8 „	+1·9	+1,000	·02	·04 scratched	
„ 21·0 „	-0·8	-450	·01	·10	
„ 5·0 „	-1·1	-2,600	·06	clean.	
„ 2·0 „	-1·0	-6,500	·14		

* The method of calculating this column may be made clearer by an example. Take the case of the first alloy in the table. The atomic weight of zinc being 65·5, a gramme-molecular weight of it, and therefore, since it is a divalent metal, of whatever combination it forms with the lead, will be contained in $100 \div 1·6 \times 65·5$ grms. of the alloy quite independently of the quantity of lead "combined." Hence the heat of formation per gramme-molecular weight is $-5·8 \times \frac{100}{1·6} \times 65·5$ calories.

III. *Scales of Seismic Intensity.* By CHARLES DAVISON,
*Sc.D., F.G.S.**

IN every country where earthquakes are studied, the want of a simple scale of seismic intensity is felt, partly in order to determine the relative intensity of different shocks, but chiefly for the purpose of drawing isoseismal lines. The use of accurately constructed seismographs cannot take the place of such a scale ; for the intensity of the shock varies so much even in one town, that they can hardly ever exist in sufficient number for the purpose of drawing isoseismal lines. The superiority of a simple scale on this point of view lies entirely in the fact that by its means we can obtain a large number of observations of the intensity from within a limited area.

Whatever the scale may be, it should satisfy the following conditions :—

1. The degrees of the scale should depend as far as possible on the mechanical effects of the shock and not on personal impressions, which may vary in different countries and with different observers in the same country or with the same observer at different times.

2. Each degree of the scale should depend on one test only, unless the exact equivalence of two tests has been determined previously.

3. The number and closeness of the degrees should be such that the scale is equally serviceable for weak, for moderately strong, and for destructive, earthquakes.

(1) *Comrie Scale.*—Brit. Assoc. Rep. 1842, p. 93.

The first attempt to devise a scale of seismic intensity was, I believe, made on behalf of a British Association Committee in 1841. A strong shock occurred on Oct. 23, 1839, having its epicentre close to Comrie, and was followed by a large number of after-shocks. Very great interest was aroused by these earthquakes, and careful records were kept by Mr. Macfarlane, postmaster of Comrie, who communicated his notes to the British Association Committee, of which Mr. David Milne (afterwards Milne-Home) was secretary. In order to furnish a rough idea of the relative intensity of these shocks as felt at Comrie, Mr. Macfarlane employed an arbitrary scale, the intensity of the earthquake of 1839 being reckoned as 10. A similar scale was used to denote the intensity of the accompanying sound. Both scales, no doubt, served the purpose for which they were intended, but they

* Communicated by the Author.

were of course, inapplicable for use in other districts and by other observers.

(2) *Mallet Scale*.—‘The Great Neapolitan Earthquake of 1857,’ vol. ii. 1862, pp. 253–256.

Mallet’s celebrated study of the Neapolitan earthquake of 1857 was founded for the most part on observations made within and near the epicentral region, and consequently the scale proposed by him is one that is chiefly applicable to destructive earthquakes. It is given twice in the work above-mentioned (pp. 253 & 255), and the two accounts of it do not exactly agree. I have endeavoured to combine both in the following table.

5. The shock perceived by instrumental disturbance.
4. The shock distinctly perceived by the unaided senses, and producing more or less alarm.
3. Universal production of fissures, and slight dislodgments in buildings ; little or no loss of life.
2. Large portions of cities and towns thrown down, persons killed and wounded by their fall.
1. The greater part of cities and towns perfectly prostrated ; great loss of life.

(3) *Philippine Scale*.—P. Miguel Saderra Maso, ‘La Seismologia en Filipinas’ (Manila, 1895), p. 21.

Father Saderra Maso’s scale, which has been in use since 1870, is well adapted for a country which is not thickly populated. The adjectives alone might not convey a very accurate impression of the intensity of the earthquakes described in the valuable memoir referred to above ; but the equivalent degrees of the Rossi-Forel scale are appended to each. These will be found in the table at the end of this paper.

1. Perceptible.
2. Slight.
3. Ordinary.
4. Strong.
5. Violent.
6. Destructive.

(4) *Rossi Scale*.—Bull. del Vulc. Ital., Anno IV. 1877, pp. 39–40.

The scale drawn up in 1873* by the late Prof. M. S. de Rossi, the well-known Italian seismologist, is a great step in

* The first form of the scale with which I am acquainted is contained in an earlier volume of the journal above-mentioned ; it was slightly modified in successive years. See Anno I. 1874, p. i ; Anno II. 1875, p. iii ; Anno III. 1876, p. i.

advance. It is applicable to shocks of every degree of intensity; and the tests are fairly definite, though they depend too much on personal impressions. It is evident that such may vary widely in different countries. In England, for instance, the Hereford earthquake of 1896, which threw down many chimneys near the epicentre, was the cause of little, if any, actual alarm. In America, on the other hand, the same degree of intensity during the Charleston earthquake of 1886 caused many persons to camp out for the night.

1. Very slight shock, noted only by seismographs or by a seismologist.

2. Weak shock, perceived by more than one.

3. Slight shock, perceived by many persons, or announced in the newspapers or by non-seismologists; and of which the duration and direction may be easily ascertained.

4. Sensible shock, making fastenings, chandelier-prisms (*cristalli*), and easily-moved articles shake; creaking of floors.

5. Moderate shock, perceived generally by very many persons, making a few bells in towns ring; felt by non-seismologists in many places not very near one another; causing beds to shake.

6. Rather strong shock *, with more or less ringing of bells, oscillation of lamps, stopping of clocks, in towns; and, in the country, visible or sensible quivering of trees and shrubs; some persons say that fortunately no damage occurred; through fear or prudence some go out into the open air; almost general interruption of sleep at night.

7. Strong shock, with fall of plaster, ringing of church bells, noise and general alarm without damage, fall of objects and pictures.

8. Very strong shock, with fall of chimney-pots, cracks in buildings, flight of persons from houses.

9. Ruinous shock, with total or partial fall of some buildings.

10. Disastrous shocks, with great destruction and loss of life.

(5) *Forel Scale*.—Arch. des Sci. phys. et nat. (Geneva), vol. vi. 1881, pp. 465-466.

Without knowing of the existence of the Rossi scale, a somewhat similar scale was devised by Prof. F. A. Forel, a prominent member of the Swiss Seismological Commission

* The original adjectives in degrees 6, 7, and 8 are "forte," "molto forte" and "fortissima"; for which we have not exactly similar expressions. In the Forel and Mercalli scales, the same or similar terms occur and are translated in the same way.

appointed by the Helvetic Society of Natural Sciences in 1878.

1. Shock of microseismometric order.
2. Extremely feeble shock, noted only by seismometric instruments.
3. Very feeble shock, perceptible to a person awake and in a peculiarly favourable condition for observation, at rest, lying down, &c.
4. Feeble shock, perceptible to persons awake and moving about, capable of waking persons who are asleep; making suspended objects or liquids oscillate.
5. Shock of moderate intensity, displacing movable objects.
6. Rather strong shock, upsetting furniture, making fissures in the walls and ceilings of houses.
7. Strong shock, damage to houses, chimneys thrown down.
8. Very strong shock, outhouses and huts thrown down.
9. Extremely strong shock, well-built houses thrown down.
10. Shock of extreme intensity, disturbance of strata, fissures in the earth's crust, rock-falls from mountains.

(6) *Rossi-Forel Scale*.—M. S. de Rossi, Bull. Vulc. Ital., Anno X. 1883, pp. 67–68; F. A. Forel, Arch. des Sci. phys. et nat., vol. xi. 1884, pp. 148–149.

Shortly after the preceding scale was drawn up, M. Forel became acquainted with the earlier one employed by de Rossi. On the invitation of the latter seismologist, they united in revising both scales; and the result will probably form the foundation of seismic scales for many years to come. The Rossi-Forel scale has been used in Italy until within the last few months. It is the standard of earthquake intensity used by seismologists in Switzerland, Great Britain, Roumania, Greece, California, and Australasia. Rough and imperfect, as no doubt it is, this scale has formed the starting-point of a distinct advance in the study of earthquakes.

Prof. E. S. Holden, who has done so much for the investigation of Californian earthquakes, has made a comparison between each degree of the Rossi-Forel scale and the corresponding maximum acceleration of an earth-particle calculated from seismographic records. His results will be found in the last column of the table given below*.

1. Recorded by a single seismograph, or by some seismographs of the same pattern, but not by several seismographs of different kinds; the shock felt by an experienced observer.

* Amer. Journ. Sci. vol. xxxv. 1888, p. 429.

2. Recorded by seismographs of different kinds; felt by a small number of persons at rest.

3. Felt by several persons at rest; strong enough for the duration or direction to be appreciable.

4. Felt by several persons in motion; disturbance of movable objects, doors, windows; creaking of floors.

5. Felt generally by everyone; disturbance of furniture and beds; ringing of some bells.

6. General awaking of those asleep; general ringing of bells; oscillation of chandeliers, stopping of clocks; visible disturbance of trees and shrubs; some startled persons leave their dwellings.

7. Overthrow of movable objects, fall of plaster, ringing of church-bells, general panic, without damage to buildings.

8. Fall of chimneys, cracks in the walls of buildings.

9. Partial or total destruction of some buildings.

10. Great disasters, ruins, disturbance of strata, fissures in the earth's crust, rock-falls from mountains.

(7) *Rockwood Scale*.—Prof. C. G. Rockwood, Jun., Amer. Journ. Sci., vol. xxxii. 1886, pp. 7-8.

Though independently formed, this is nearly the same as that used in the Philippine Islands. It resembles the latter also in consisting of adjectives only, the significance of which would be indeterminate, if the author had not expressed them in terms of the degrees of the Rossi-Forel scale.

1. Very light.

2. Light.

3. Moderate.

4. Strong.

5. Severe.

6. Destructive.

(8) *Baratta Scale*.—M. Baratta, "Il terremoto Veronese del 7 giugno 1891": *Annali dell' Ufficio Meteorologico e Geodinamico*, vol. xi. (for 1889), 1892, p. 19.

So far as I know, this scale has only been used in the study of the Verona earthquake of 1891. It resembles rather closely the modification of the Rossi-Forel scale which I have employed in investigating British earthquakes.

1. Very slight, noted by instruments only.

2. Slight, felt by a few persons without the aid of instruments.

3. Moderate, accompanied by general shaking of fastenings, crystals, &c.

4. Strong, with more or less general ringing of bells, stopping of clocks, oscillation of lamps.
5. Very strong, with fall of plaster and of a few chimney-pots, cracks in buildings, ringing of bells.
6. Almost ruinous, with total or partial fall of a few (one or two) buildings.
7. Ruinous ; ruin of several buildings, a little loss of life.

(9) *Japanese Scale*.—Report on Earthquake Observations in Japan (1892), p. 10.

With the exception of the Comrie scale, that employed in Japan is less useful than any other mentioned in this paper, on account of the small number of degrees which it contains. At first sight, it is surprising that this should be the case in the country which possesses the most complete organization for the study of earthquakes. One reason may be the reliance placed on seismographs, but I think that the chief reason lies in the great frequency of earthquakes in many parts of Japan. With the exception of those which are unusually strong for the districts concerned, records are obtainable as a rule only from previously prepared observers. The detailed inquiries which are possible in Great Britain can hardly be made in a country in which the recollection of one shock is soon after dimmed or erased by the occurrence of another or many more in rapid succession.

1. Slight, just sufficient to be felt.
2. Weak, when the motion is distinctly felt, but not so violent as to be necessary for people to run out-of-doors.
3. Strong, when most people run out-of-doors, some pieces of furniture are overturned, liquids thrown out, buildings damaged, the ground cracked or rent.

(10) *Mercalli Scale*.—Prof. G. Mercalli, ‘I Terremoti della Liguria e del Piemonte,’ p. 20 (Naples, 1897).

The Mercalli scale is a modification of the Rossi-Forel scale, and is now adopted as the standard of the Central Office of Meteorology and Geodynamics at Rome. The degrees do not correspond exactly with those of the Rossi-Forel scale, and the equivalents given in the Table below are only approximate. The limitation of both scales to *ten* degrees renders the Mercalli scale rather more suitable for disastrous earthquakes, and the Rossi-Forel scale for shocks of moderate intensity.

1. Instrumental shock, that is, noted by seismic instruments only.

Phil. Mag. S. 5. Vol. 50. No. 302. July 1900, E

2. Very slight, felt only by a few persons in conditions of perfect quiet, especially on the upper floors of houses, or by many sensitive and nervous persons.

3. Slight, felt by several persons, but by few relatively to the number of inhabitants in a given place; said by them to have been *hardly felt*, without causing any alarm, and in general without their being sensible that it was an earthquake until it was known that others had also felt it.

4. Sensible or moderate, not felt generally, but felt by many persons indoors, though by few on the ground-floor, without causing any alarm, but with shaking of fastenings, crystals, creaking of floors, and slight oscillation of suspended objects.

5. Rather strong, felt generally indoors, but by few outside, with waking of those asleep, with alarm of some persons, rattling of doors, ringing of bells, rather large oscillation of suspended objects, stopping of clocks.

6. Strong, felt by everyone indoors, and by many with alarm and flight into the open air; fall of objects in houses, fall of plaster, with some slight cracks in badly-built houses.

7. Very strong, felt with general alarm and flight from houses, sensible also out-of-doors; ringing of church-bells, fall of chimney-pots and tiles; cracks in numerous buildings, but generally slight.

8. Ruinous, felt with great alarm, partial ruin of some houses, and frequent and considerable cracks in others; without loss of life, or only with a few isolated cases of personal injury.

9. Disastrous, with complete or nearly complete ruin of some houses and serious cracks in many others, so as to render them uninhabitable; a few lives lost in different parts of populated places.

10. Very disastrous, with ruin of many buildings and great loss of life, cracks in the ground, landslips from mountains, &c.

(11) *Oldham Scale*.—Mem. Geol. Survey of India, vol. xxix. 1899, pp. 42-43.

The country over which the great Indian earthquake of 1897 was felt is "largely a wild, thinly populated country, and even in the thickly-populated parts brick and stone buildings are rare and widely scattered." In studying this earthquake, Mr. R. D. Oldham therefore found it impossible to define more than the following degrees of intensity:—

1. The destruction of brick and stone buildings practically universal.

2. The damage to masonry or brick buildings universal and often serious, amounting in some cases to destruction.

3. All, or nearly all, brick buildings damaged.

4. The earthquake universally felt, severe enough to disturb furniture and loose objects, but not to cause damage (except in a few instances) to brick buildings.

5. The earthquake smart enough to be generally noticed, but not severe enough to cause any damage.

6. The earthquake only noticed by a small proportion of people who happened to be sensitive, and, being seated or lying down, were favourably situated for observing it.

(12) *Scale used in studying British Earthquakes.*—The scale which I have used in studying British earthquakes differs but little from the Rossi-Forel scale. The number of tests in each degree is reduced to one in nearly every case, thus allowing the isoseismal lines to be drawn with greater accuracy than is attainable in a less thickly-populated country, in which single tests might be seldom applicable. In districts which are visited by destructive earthquakes, two additional degrees, corresponding to degrees 9 and 10 of the Rossi-Forel scale, would be required.

1. Recorded only by instruments.

2. Felt only by a few persons lying down and sensitive to weak tremors.

3. Felt by ordinary persons at rest, not strong enough to disturb loose objects.

4. Windows, doors, fire-irons, &c. made to rattle.

5. The observer's seat perceptively raised or moved.

6. Chandeliers, pictures, &c. made to swing.

7. Ornaments, vases, &c. overthrown.

8. Chimneys thrown down and cracks made in the walls of some, but not many, houses in one place.

9. Chimneys thrown down and cracks made in the walls of about one-half of the houses in one place.

Comparison of different Scales.—In the following Table I have endeavoured to express the degrees of different scales in terms of those of the Rossi-Forel scale. An asterisk affixed to the name of a scale indicates that the correlation given is due to the author of the scale himself.

On Scales of Seismic Intensity.

Rossi-Forel.	Mallet.	Philip-pine #.	Rossi.	Forel #.	Rock-wood #.	Baratta.	Japanese.	Mercalli.	Oldham #.	British #.	Maximum Acceleration in mm. per sec. per sec.
1	5	...	1	1,2	...	1	...	1	...	1	20
2	}	}	2	}	}	}	}	2	}	2	40
3			3					1		3	6
4	}	}	4	}	}	}	}	4	}	4	80
5			5					2		5	5
6	}	}	6	}	}	}	}	5	}	6	150
7			7					3		4	4
8	}	}	8	}	}	}	}	6	}	7	500
9			9					5		7	5
10	1	6	10	8,9	6	6,7	3	7,8,9	2	...	1200
				10		...		10	1

Postscript.—Since the above paper was written a valuable memoir by Prof. Omori on “Seismic Experiments on the Fracturing and Overturning of Columns” (Publications of the Earthquake Investigation Committee in Foreign Languages, No. 4, Tokyo, 1900, pp. 69–141), has reached this country. At the close of the memoir (pp. 137–141) he gives an “absolute scale of destructive earthquakes,” the maximum acceleration corresponding to each degree being 300, 900, 1200, 2000, 2500, 4000, and more than 4000 mm. per sec. per sec. respectively. The effects of a shock of each degree on buildings &c. are described in detail. It appears also that the Japanese scale has been modified slightly since 1892. The form given by Prof. Omori is as follows, the corresponding degrees of the Rossi-Forel scale being added in brackets:—Slight (1, 2), Weak (3 to 5), Strong (6, 7), Violent (8 to 10 and above).

IV. *Elastic Constants of Rocks and the Velocity of Seismic Waves.* By H. NAGAOKA, Professor of Applied Mathematics, Imperial University, Tōkyō*.

THE vibration of the earth's crust has from time to time been a favourite subject of discussion among the elasticians, and the propagation of seismic disturbance is a problem whose solution has long been hoped for, both from the theoretical and the empirical point of view. With improved instruments, seismologists have recently determined the velocity of propagation with tolerable accuracy, but very little is known of the elastic nature of the medium through which the vibration has travelled. The resources from which physicists and seismologists draw their theoretical inferences are so scanty, that among the numerous rocks which constitute the earth's crust, only a few of the most commonly occurring rocks have had their physical properties investigated. The questions of elasticity, having close bearing with the deformation of the earth's crust, have repeatedly been a subject of research by several distinguished elasticians as Lord Kelvin, Boussinesq, Cerruti, and Chree. But we are baffled in our attempt to apply the result of subtle analysis to the actual problem, from the lack of experimental knowledge as regards the elastic nature of the diverse rocks which compose the outer coating of our planet. The present experiments were undertaken with a view to fill these gaps, and to supply

* Reprinted from the Publications of the Earthquake Investigation Committee in Foreign Languages, no. 4. Communicated by the Author.

on the one hand the wants of physicists, whose aim is to apply dynamics to the study of the geological phenomena, and on the other to meet the needs of seismologists, engaged in solving the problems touching the propagation of seismic waves.

Preparation of the Specimens.—The present experiments deal principally with the determination of Young's modulus and the modulus of rigidity, made on specimens of rocks which were easily accessible.

The number of rocks examined amounted to about eighty different specimens collected from various localities. These rocks were first cut in the shape of a rectangular parallelepiped, and afterwards carefully polished into prisms of nearly 1 centim. square cross-section and 15 centim. length. It was at first proposed to experiment with much larger specimens, but it was generally found impossible to find a large homogeneous piece with no trace of cleavage; in addition to this, the apparatus with which the elastic constants were to be measured would become cumbrously large, and require great solidity, increasing at the same time the difficulties of experiment.

Most of the specimens were apparently isotropic, but on close examination it was found that the isotropy was only superficial. Rocks as slates with distinct sedimentation planes were generally cut parallel and perpendicular to them; where such planes of symmetry were not easily discernible, the specimen was conveniently cut into prisms.

The thickness of these prisms was measured by a contact micrometer reading, by means of a vernier, to $\frac{1}{100}$ millim. at three different places in the middle line of two opposite faces; namely, one at the middle and two at one quarter distance from the ends. The mean density of the prism was measured by dividing the mass by the volume, which was calculated from the known length and thickness. The density of several prisms cut from the same sample did not generally agree, showing that the material was only roughly homogeneous.

Modulus of Elasticity.—Young's modulus was measured by flexure experiment. The specimen to be tested was placed on two steel wedges, which served as fulcrums. The edge of the wedge was slightly rounded in order to prevent cutting on applying heavy weights. The flexure due to the weight hung at the middle of the prism was measured by means of a scale and telescope. By a special arrangement, a plane mirror was attached to the prism at the place where it rested on the wedges. The mirror was nearly vertical and the image

of the vertical scale divided in millim., and placed at a distance of 2.73 m., was observed by a telescope provided with a filar micrometer. By this means, the deflexion of 1" was easily measurable.

Denoting the length and the thickness of the prism by l and c respectively, the distance between the fulcrums by a , and the angle of deflexion by δ , we obtain for the modulus of elasticity E

$$E = \frac{3W a^2}{4bc^3 \delta},$$

where W stands for the weight suspended in the middle of the prism.

The elastic heterogeneity of rocks called for the necessity of examining the constants in different directions; for this purpose, the prism was placed on its different faces on the fulcrum and the moduli for two mutually perpendicular directions were generally measured. These are denoted by E_1 and E_2 in the table of the elastic constants, and the mean of these two by E .

Modulus of Rigidity.—The modulus of rigidity was determined by measuring the amount of torsion produced by a given couple. It would lead too far were I to attempt to describe

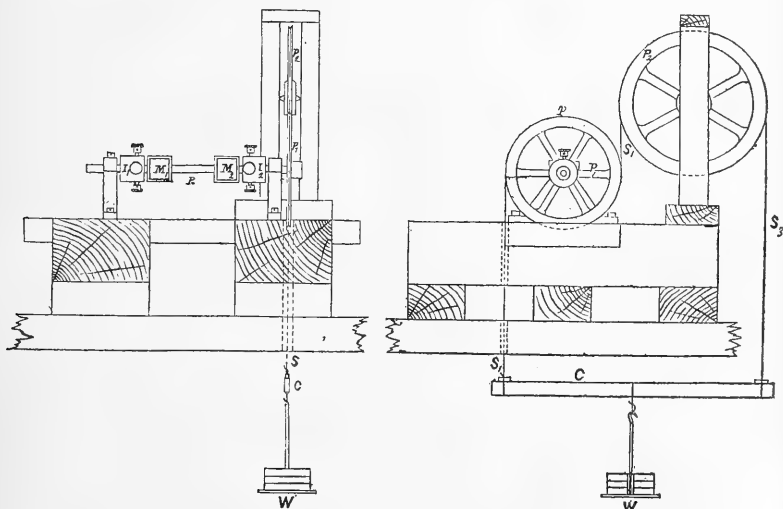

the details of the instrument. The rectangular prism R was placed horizontal and firmly clamped at both its extremities to two solid pieces, I_1 , I_2 of iron. In order to prevent cracking by too firmly clamping, four small pieces of brass plate

with thin sheet lead underneath were interposed between the four faces of the prism and the clamping screws. I_1 was fixed to a solid iron frame. The central steel cylinder protruding from I_2 was filed down to a sharp knife-edge on its axis, coinciding with the central line of the prism. An agate plane attached to another solid iron frame supported the knife-edge and the twisting pulley P. To the cylinder above referred to, a pulley P_1 of 14 centim. diameter was firmly fixed; a flexible string s_1 attached to a pin p on the circumference of the pulley passed over it, and was tied to a light wooden cross-bar c . Another string s_2 was attached to the pulley, and instead of passing over it, was slung around another pulley P_2 such that the line of passage s_2 from P_1 to P_2 was vertical. The string on going over P_2 in the opposite direction to the former string was again let down vertical and attached to the cross-bar. By hanging the weight at the middle of the bar, the tension was the same in both strings and gave rise to a couple = radius of the pulley \times weight. By this arrangement, the knife-edge did not support the load producing the twisting couple, that of the prism, clamp, and pulley being the only weight acting. The amount of torsion was measured by observing the deflexion of two mirrors M_1 and M_2 , one attached to the prism near the fixed clamp I_1 and the other near I_2 . The deflexions, as measured by a vertical scale and two telescopes, were generally large compared with those in flexure experiments, so that no micrometric measurement was needed. The difference between the two scale-readings gave the torsion between the two places where the mirrors were fixed by special clamp screws.

Denoting the sides of the prism by b and c , the torsion for unit length by τ , the twisting couple by N , and the rigidity by μ , we get by St. Venant's formula for the torsion of a rectangular prism the following expression for N

$$N = \mu \tau b^3 c \left\{ \frac{16}{3} - \frac{b}{c} \left(\frac{4}{\pi} \right) \sum \frac{1}{(2n-1)^5} e^{\frac{\left(\frac{2n-1}{2b}\right)\pi c}{e} - \frac{\left(\frac{2n-1}{2b}\right)\pi c}{-e}} \right\}.$$

It may be a question whether it is justifiable to use St. Venant's formula in the present experiment, as the boundary conditions are somewhat different from those considered by St. Venant in deducing the above result. As the length of the prism was large compared with its thickness, and as the twist τ was measured at points not very near the ends of the prism, the result given by using the above formula will not be materially

different from the actual value. When the rock is of stratified structure and shows great difference in its elastic behaviour the formula will require modification, but in studying the elasticity of rocks in its broad features, the modulus of rigidity calculated in the above manner will not be far from the general mean. The calculation of the series involved in the above formula is somewhat tedious. Fortunately, St. Venant has calculated a table of

$$\sum \frac{1}{(2n-1)^5} e \frac{\left(\frac{2n-1}{2b}\right)^{\pi c} - e^{-\left(\frac{2n-1}{2b}\right)^{\pi c}}}{\left(\frac{2n-1}{2b}\right)^{\pi c} + e^{-\left(\frac{2n-1}{2b}\right)^{\pi c}}}$$

for different values of $\frac{c}{b}$. As the section of the prism was nearly square shaped, it was thought advisable to calculate the sum of the series at small intervals, when the ratio $\frac{c}{b}$ is nearly unity. As such tables will sometimes be found useful, I give the result of calculation in the following table:—

Table of $\frac{16}{3} - \frac{b}{c} \left(\frac{4}{\pi}\right)^5 \sum \frac{1}{(2n-1)^5} e \frac{\left(\frac{2n-1}{2b}\right)^{\pi c} - e^{-\left(\frac{2n-1}{2b}\right)^{\pi c}}}{\left(\frac{2n-1}{2b}\right)^{\pi c} + e^{-\left(\frac{2n-1}{2b}\right)^{\pi c}}} = \beta.$

$\frac{c}{b}$	β	$\frac{c}{b}$	β
1.00	2.249	1.15	2.563
1.01	2.272	1.16	2.583
1.02	2.294	1.17	2.602
1.03	2.316	1.18	2.621
1.04	2.338	1.19	2.639
1.05	2.359	1.20	2.658
1.06	2.379	1.21	2.676
1.07	2.402	1.22	2.694
1.08	2.422	1.23	2.713
1.09	2.443	1.24	2.730
1.10	2.464	1.25	2.748
1.11	2.484		
1.12	2.504		
1.13	2.524		
1.14	2.543		

Hooke's Law and Elastic After-Effect.—Preliminary experiments with granite showed that Hooke's law does not hold even for very small flexure and torsion, and that the after-effect is very considerable when the prism is sufficiently loaded or twisted; the deviation from the direct proportionality between the strain and stress was incomparably great compared with that observed in common metals. This must be chiefly due to the low limit of elasticity, so that it is necessary to experiment only within narrow limits of loading or twisting. These limits are widely different for different specimens of rocks, and the modulus of elasticity as well as that of rigidity was always determined with such stresses as will approximately produce strains proportional to them.

The deviation from Hooke's law was prominent in certain specimens of sandstones, and it was more marked in torsion than in flexure experiments. In certain rocks it is indeed doubtful if anything like a proportionality between stress and strain can be found even for extremely small change of shape. On releasing these rocks from stress the return towards the former state is extremely small, showing that the elasticity of rocks is of very inferior order. The elastic yielding of rocks under continuous action of stress is very remarkable, as the following readings of the deflexion in the experiment on torsion will show.

Specimen: Izumi Sandstein.

$a = 100.0$ mm., $b = 10.12$ mm., $c = 10.09$ mm.

Torsional loading, 400 grms.

Zero reading before loading, 24.2.

Loaded 2^h 18^m.0 Sept. 10, 1898.

Time.		Reading.	Time.		Reading.
h.	m.		h.	m.	
2	18.1	72.0	2	24.0	82.4
	18.5	75.3		25.0	83.6
	19.0	77.1		27.0	84.1
	19.5	78.1		28.0	84.5
	20.0	78.9		29.0	84.9
	20.5	79.6		30.0	85.2
	21.0	80.1		31.0	85.5
	21.5	80.6		32.0	85.9
	22.0	81.0		33.0	86.2
	22.5	81.4		34.0	86.5
	23.0	81.8		35.0	86.8
	23.5	82.1			

It will be seen that the initial deflexion amounts to 47·8 mm.; the torsion of the prism gradually increases in course of a few minutes, so that after a lapse of about 19 minutes the increase of deflexion is nearly 30 per cent. of the initial. The increase becomes asymptotic with time.

The above-mentioned property of rocks will be of no small interest in dynamical geology, as it naturally illustrates the possibility of the folding of rocks and other kindred phenomena pertaining to the manifold change of shape in rocks, wrought by the continuous action of stress.

Velocity of Elastic Waves.—It was my intention to determine the modulus of elasticity, and then calculate the velocity of propagation of the longitudinal as well as that of the transversal waves, on the supposition that the material is isotropic. A few experiments with rocks of different ages showed that these attempts are for the most part fruitless, as the assumption of isotropy was not generally admissible. With archæan and palæozoic rocks it was possible to work them into proper shape for experiment only in a certain direction, as they were generally of schistose structure, and extremely brittle in the direction perpendicular to it; in such cases the elastic behaviour was of course widely different in these directions. Even with granite, which apparently is homogeneous in structure, the difference of elasticity with direction was noticed. On examination, these rocks were found to have been pressed from one side during formation, and this left its trace in the relation of strain to stress. For the complete discussion of the elastic nature of these rocks the determination of the moduli of elasticity and of rigidity considered as an isotropic substance is insufficient; we are in fact dealing with quasi-crystalline bodies, so that the number of elastic constants must depend on the number of symmetry-planes which can be drawn in these rocks. The type of the elastic waves travelling in such a medium will be determined, when all of these constants are known. As we have no simple means of examining these symmetry-planes, a single modulus of elasticity and rigidity was determined, on the supposition that the material is isotropic.

In the discussion of the propagation of seismic waves we have to deal with wave-lengths which measure over a kilometre. Geologists tell us that uniform strata of a kilometre thickness are of rare occurrence; and it may be doubted if these waves do not suffer change of type and shape in traversing the earth's crust. Unquestionably longitudinal plane waves whose velocity of propagation in an isotropic medium

is given by the formula $\sqrt{\frac{\lambda+2\mu}{\rho}}$ (following Lamé's notation) would seldom come into existence. A complete discussion of waves in quasi-crystalline rocks requires complicated analysis, which necessitates the knowledge of the elastic behaviour of rocks cut in various directions. To obtain a general view of the propagation I have thought it advisable to calculate $V_l = \sqrt{\frac{E}{\rho}}$ for the longitudinal waves. Suppose the Young's modulus E is determined by flexure experiments on a prism cut parallel to a plane of symmetry, then V_l will give the velocity of longitudinal waves travelling along the prism. The velocity in the sense above explained is given under V_l , and the velocity of the transversal wave $\sqrt{\frac{\mu}{\rho}}$ under V_t . I do not mean to say that the actual velocity of longitudinal waves in various rocks is given by V_l ; but when such values are not obtainable, V_l will probably give a rough estimate. The elastic constants of rocks are tabulated in the order of geological age; for the same geological age those with larger velocity of propagation V_l come before those with the slower.

Elastic Constants of Rocks.

Rock.	Spec. No.	ρ .	E_1 (c.g.s.).	E_2 (c.g.s.).	E (c.g.s.).	μ (c.g.s.).	$V_l \frac{\text{kilm.}}{\text{sec.}}$	$V_t \frac{\text{kilm.}}{\text{sec.}}$
ARCHÆAN ROCKS.								
Chlorite Schist (<i>Chichibu</i>)	9	2.977	112.1×10^{10}	132.4×10^{10}	122.3×10^{10}	24.03×10^{10}	6.40	2.84
	50	2.955	146.0	147.6	146.8	31.57	7.05	3.27
(Eruptive.)								
Peridotite Serpentine (<i>Kuzi</i>)	16	2.825	72.92	58.99	65.96	22.24	4.83	2.81
	41a	2.777	62.42	55.86	59.14	20.09	4.61	2.69
Peridotite Serpentine	41b	2.786	54.15	53.90	54.03	19.73	4.41	2.66
	45	2.593	38.90	53.71	46.31	4.22
Peridotite Serpentine	17	2.570	39.03	46.00	32.52	16.00	4.07	2.49

Rock.	Spec. No.	ρ .	E_1 (c.g.s.)	E_2 (c.g.s.)	E (c.g.s.)	μ (c.g.s.)	V_l $\frac{\text{kilm.}}{\text{sec.}}$	V_t $\frac{\text{kilm.}}{\text{sec.}}$
PALÆOZOIC ROCKS.								
Schalstein (<i>Rikuchyū</i>)	79	2.653	120.50 × 10 ¹⁰	92.25 × 10 ¹⁰	106.4 × 10 ¹⁰	18.90 × 10 ¹⁰	6.32	2.67
Clayslate (<i>Nikkō</i>)	74	2.149	79.69	83.29	81.49	28.06	6.16	3.61
Schalstein (<i>Rikuchyū</i>)	78 _a	2.768	70.02	95.00	82.51	25.36	5.45	3.03
	78 _b	2.772	97.90	103.30	100.60	21.25	6.02	2.77
Sandy Slate (<i>Rikuchyū</i>)	73	2.640	81.79	92.40	82.10	17.05	5.75	2.54
	2 _a	2.674	98.00	83.09	90.55	13.79	5.82	2.27
Clayslate.....	2 _b	2.690	90.64	86.71	88.68	20.75	5.74	2.78
	2 _c	2.708	51.92	62.26	57.09	20.74	4.52	2.77
Limestone (<i>Musashi</i>)	55	2.630	84.95	88.45	86.20	29.83	5.74	3.38
Limestone	13	2.653	80.20	86.61	83.40	31.00	5.60	3.42
Limestone (<i>Musashi</i>)	29	2.682	68.86	79.55	74.20	21.71	5.26	2.84
Weathered Clayslate	1 _a	2.314	62.15	61.35	61.75	10.03	5.18	2.08
	1 _b	2.304	56.83	58.90	57.87	8.85	5.01	1.96
Marble	11 _a	2.654	76.0	63.72	69.86	30.11	5.13	3.37
	11 _b	2.625	63.53	46.2	54.86	28.60	4.54	3.45
Schalstein	80	2.824	74.60	70.52	72.56	18.96	5.07	2.58
Schalstein (<i>Tosa</i>)	75	2.762	57.68	37.70	47.69	8.98	4.63	1.80
Weathered Clayslate	60 _a	2.316	39.44	35.27	37.36	4.99	4.02	1.47
	60 _b	2.306	35.37	36.69	36.03	5.27	3.96	1.51
Marble	12 _a	2.650	37.26	37.64	37.45	15.08	3.76	2.39
	12 _b	2.650	37.33	28.33	32.82	18.80	3.93	2.66
Clayslate (<i>Tanba</i>)	3 _a	2.384	34.48	30.76	32.62	8.00	3.70	1.83
	3 _b	2.392	30.64	30.35	30.50	8.54	3.57	1.87
Contact Clay- slate (<i>Mikawa</i>)	64 _a	2.462	30.35	28.10	29.23	3.45	1.81
	64 _b	2.416	31.00	31.86	31.43	3.61
Weathered Clayslate	7 _a	2.503	12.45	12.20	12.33	4.60	2.32	1.36
	7 _b	2.500	13.00	13.64	13.32	4.31	2.31	1.31
Weathered Clayslate	65 _a	2.490	12.72	12.26	12.49	6.59	2.24	1.63
	65 _b	2.500	12.54	12.47	12.51	4.43	2.24	1.33
(Eruptive.)								
Granite (<i>Shōdoshima</i>)	69	2.572	37.91	46.71	42.31	18.43	4.05	2.68
Granite	42	2.550	31.42	13.99	3.51	2.34
Granite (<i>Hitachi</i>)	68	2.549	18.83	20.43	19.63	6.89	2.78	1.64
Granite (<i>Hitachi</i>)	71	2.590	14.84	15.12	14.98	5.05	2.42	1.40
Granite	52	2.503	15.23	9.73	22.48	5.47	2.22	1.48
Granite (<i>Hitachi</i>)	56	2.530	11.97	9.89	10.93	4.43	2.08	1.32
MESOZOIC ROCKS.								
Izumi Sandstein	5	2.216	9.2	9.0	9.12	3.1	2.03	1.18
	6 _a	2.236	7.1	7.2	7.12	2.4	1.78	1.04
	6 _b	2.223	7.7	7.6	7.67	2.7	1.86	1.10
Schalstein	77	2.778	75.7	83.0	79.4	23.2	5.35	2.89
Clayslate (<i>Rikuchyū</i>)	72	2.711	88.4	99.3	98.8	22.6	5.88	2.89
Clayslate (<i>Rikuchyū</i>)	53	2.702	83.6	85.3	84.5	18.5	5.59	3.17
Clayslate (<i>Tsushima</i>)	62 _a	2.681	32.2	50.6	41.4	14.8	3.91	2.35
	62 _b	2.678	43.7	44.3	44.0	14.2	4.06	2.31

Rock.	Spec. No.	ρ .	E_1 (c.g.s.).	E_2 (c.g.s.).	E (c.g.s.).	μ (c.g.s.).	V_t $\frac{\text{kilm.}}{\text{sec.}}$	V_t $\frac{\text{kilm.}}{\text{sec.}}$
CAINOZOIC ROCKS (Tertiary).								
Rhyolite (<i>Izu</i>) ...	51	2.316	32.1×10^{10}	17.5×10^{10}	24.8×10^{10}	14.0×10^{10}	3.24	2.46
Rhyolite Tuff	8a	2.346	21.9	21.5	21.73	9.32	3.05	1.99
(<i>Iyo</i>)	8b	2.316	21.8	20.0	20.90	8.05	3.01	1.86
Tuff Sandstone	19a	2.305	20.6	21.1	20.8	8.74	3.02	1.95
(<i>Kōzuke</i>)	19b	2.321	21.2	21.4	21.3	8.45	3.02	1.91
Rhyolite	59a	2.472	21.3	18.7	20.0	8.57	5.85	1.86
(<i>Kōzuke</i>)	59b	2.454	19.5	18.3	18.9	9.15	2.78	1.93
Rhyolite Tuff	63a	2.228	18.8	19.9	19.3	6.9	3.00	1.79
(<i>Mikawa</i>)	63b	2.198	17.4	11.8	14.6	2.59
Rhyolite (<i>Izu</i>)	27a	1.945	11.3	11.7	11.5	5.78	2.43	1.72
	27b	1.944	14.0	15.1	14.6	5.86	2.74	1.74
Rhyolite Tuff	32	1.889	8.1	10.1	9.1	4.2	2.20	1.49
Sandstone	58	2.345	10.9	11.4	11.2	4.60	2.18	1.40
(<i>Chōshi</i>)								
Rhyolite Tuff	66	2.263	8.0	7.59	7.80	3.59	1.86	1.26
(<i>Amakusa</i>)								
Rhyolite	61a	2.228	10.8	11.1	10.96	6.25	2.22	1.51
(<i>Iwashiro</i>)	61b	2.198	9.8	9.6	9.67	5.66	2.10	1.67
Rhyolite Tuff	43	1.371	1.43	2.49	1.96	1.06	1.19	0.89
(<i>Tochigi</i>)								
(Diluvium.)								
Tuff	36	1.850	35.7	6.235	4.39	1.84
Andesite.....	54	2.557	43.9	45.8	44.9	18.50	4.19	2.69
Andesite.....	70	2.462	45.5	26.7	36.1	11.69	3.80	2.18
Tuff	30	2.169	28.3	27.6	27.95	10.99	3.59	2.25
Andesite.....	15	2.201	29.2	23.6	26.38	12.57	3.45	2.39
Tuff	10	2.283	24.3	24.9	24.62	10.74	3.28	2.17
Tuff	14	2.222	21.6	22.8	22.2	8.48	3.18	1.96
Andesite.....	28	2.165	19.46	27.75	23.51	12.15	3.24	2.37
Andesite.....	39	2.397	23.07	20.4	21.73	10.13	3.01	2.06
Tuff	20	1.859	14.4	14.5	14.41	5.07	2.79	1.65
Tuff	4a	1.838	10.9	11.86	11.40	4.56	2.99	1.58
	4b	1.817	12.0	12.60	12.33	3.88	2.60	1.46
Andesite.....	40	2.302	14.76	12.6	13.68	5.99	2.44	1.61
Tuff	57	2.039	11.26	10.70	10.98	5.51	2.32	1.65
Andesite Tuff	67a	2.435	13.15	12.77	12.96	5.78	2.31	1.54
(<i>Echizen</i>)	67b	2.400	13.57	13.21	13.39	5.55	2.37	1.52
Andesite.....	38	1.943	10.30	10.39	10.35	4.13	2.31	1.46
Andesite.....	49	2.158	8.96	13.1	21.0	5.26	2.26	1.56
Andesite Tuff ...	23	1.829	8.23	8.48	8.36	3.92	2.14	1.46
Andesite.....	34	2.022	9.17	8.44	8.81	6.00	2.09	1.72
Andesite.....	47	2.425	8.51	8.38	8.45	4.06	1.86	1.29
Tuff (<i>Izu</i>)	31	1.915	7.53	5.82	6.68	1.86
Tuff	33	1.819	6.23	6.42	6.33	1.87
Andesite	46	2.574	8.87	8.36	8.62	2.92	1.83	1.07
Andesite (<i>Izu</i>)	25a	1.984	6.57	5.12	5.85	1.236	1.72	0.79
	25b	1.632	5.57	5.14	5.36	1.63	1.60	0.88
Andesite	48	2.102	5.51	6.81	6.16	2.47	1.71	1.08
Andesite Tuff.....	21	1.497	3.74	4.12	3.93	1.39	1.62	0.97
Tuff (<i>Izu</i>)	35	1.286	3.45	3.31	3.38	1.50	1.62	1.08
Tuff (<i>Awa</i>).....	44	1.448	2.72	3.87	3.30	1.17	1.50	0.90
? Quartz Sandstone	24	2.138	4.04	4.05	4.05	1.30	1.37	0.78
? Quartz Sandstone	37	2.230	4.02	4.02	1.34

Some of the specimens which have been examined are nearly isotropic. Most of these rocks are of recent formation. For these I have calculated the velocities of propagation of longitudinal waves in unlimited medium

$$V = \sqrt{\frac{\lambda + 2\mu}{\rho}} \left(= \sqrt{\frac{k + \frac{4}{3}n}{\rho}}, \text{ using Lord Kelvin's notation} \right),$$

which are placed under the following table.

Rock.	Age.	Density.	$V = \sqrt{\frac{\lambda + 2\mu}{\rho}} \left(\frac{\text{kilm.}}{\text{sec.}} \right).$	$V_t = \sqrt{\frac{\mu}{\rho}}.$
Peridotite	Algonkian.	2.786	5.86	2.68
Serpentine.	"	2.654	4.09	3.37
Marble	Palæozoic.	2.490	2.25	1.63
Weathered Clayslate.	"	2.236	2.93	1.04
Idzumi Sandstein	Mesozoic.	2.223	2.76	1.10
Tuff Sandstone	"	2.321	3.35	1.91
"	Tertiary.	2.305	3.16	1.95
Rhyolite Tuff	"	2.316	3.18	1.86
"	"	2.346	3.11	1.99
Rhyolite	"	1.944	3.02	1.74
"	"	2.454	2.78	1.93
Rhyolite Tuff	"	2.228	2.25	1.51
"	"	2.198	2.14	1.67
"	"	2.263	1.88	1.26
Tuff	Diluvium.	2.537	4.44	2.69
"	"	2.167	4.02	2.25
"	"	2.222	3.77	1.96
"	"	2.283	3.38	2.17
Andesite	"	2.397	3.06	2.06
Tuff	"	1.838	2.75	1.58
Andesite Tuff	"	2.014	2.58	1.56
Andesite	"	2.547	2.57	1.77
"	"	1.943	2.54	1.46
Andesite Tuff	"	2.400	2.50	1.52
"	"	2.435	2.35	1.54
Tuff	"	2.039	2.32	1.65
Andesite	"	2.022	2.21	1.72

I did not think it necessary to calculate the velocity of surface-waves, which according to Lord Rayleigh amounts to $0.9554 \sqrt{\frac{\mu}{\rho}}$, as the difference of rigidity in different specimens is so great that the presence of the factor 0.9554 will not materially affect the result.

General Result.—In examining the elastic constants of rocks classified according to the age of formation, we find a distinct gradation as we pass from those of recent formation to the oldest. The increase of density, as well as the quasi-crystalline behaviour of rocks, is the most important characteristic of rocks which are deeply embedded in the

earth's crust. The chlorite schist of Chichibu has a density nearly equal to 3, although its modulus of elasticity is greater than that of brass or copper with a rod cut in the direction of strongest tenacity, it is so brittle in the direction perpendicular to it that it is impossible to obtain a single specimen with which the elastic constant can be accurately determined. The elastic constants are widely different as the specimen is cut in one or other direction, especially in archæan and palæozoic rocks, as schists and slates with distinct sedimentation planes. Rocks of eruptive origin are generally free from such directional behaviour; but when they are pressed or otherwise subject to continuous application of stress, the difference of elasticity in different directions can still be traced. Such appears to be the case with marble and granite.

The elastic constants of archæan and palæozoic rocks are far superior to those of the cainozoic; but the velocity of propagation of longitudinal or transversal waves is not proportionally large. As the ratio of the elastic constant to density determines the velocity of propagation, we cannot at once conclude from the increase of elasticity that the waves travel with greater velocity. It would be too bold to draw anything like a general conclusion from the examination of some eighty specimens; but so far as the present experiments go, the tendency is such that the elastic constants increase more rapidly than the density as the rock becomes denser, and consequently elastic waves travel with greater velocity in the interior than on the surface of the earth's crust. Eruptive rocks are more isotropic than those of non-igneous origin, and have inferior elasticity; but there is the same distinction with age. Elastic waves in eruptive palæozoic rocks travel with slower velocity than in those of the archæan of the same origin; a similar remark applies to cainozoic rocks with a few exceptions.

As we go deep in the earth's crust the rocks generally assume schistose structure; we have reason to believe that the elastic constants of the constituent rocks increase in a certain particular direction, which evidently coincides with that of swiftest propagation of elastic disturbance. Pressed by the weight of the superincumbent crust, these rocks will be of greater density; so that the increase of elastic constants is attended with corresponding increase of density. We cannot conceive that the elastic constant or the density will continually increase as we approach the centre of the earth; they will both attain asymptotic values. The alternatives are: either the ratio of elastic constants to density goes on gradually increasing, or it first reaches a maximum and then

goes on decreasing. The former supposition makes the velocity of elastic waves increase from the surface towards the centre of the earth, while the latter implies the existence of the *stratum of maximum velocity of propagation*. Such a stratum, if it exists, will lie pretty deep in the earth's crust, and will be inaccessible to us ; but the question will be settled by the seismologists.

Velocity of Propagation of Seismic Waves.—A glance at the table of elastic constants will show the complex elastic nature of rocks composing the earth's crust. The path pursued by waves of disturbance must necessarily assume very complicated forms, as they are subject to manifold reflexion, refraction, and dispersion. We can perhaps borrow analogy from a kindred optical phenomenon of curved rays in a medium of heterogeneous density, studied experimentally by Macé de Lépinay and Perot, and theoretically discussed by A. Schmidt and Wiener. The phenomena presented by the seismic wave will be of still more complex character as the medium is of quasi-crystalline nature, and the wave may suffer refraction something akin to that of light in Iceland-spar and arragonite. The elastic constants of rocks through which the disturbance propagates will rarely satisfy the condition of giving rise to purely longitudinal or distortional waves, so that the seismic wave will be of a mixed character. What Mr. Milne designates earthquake echoes or reverberations will partly find explanation in the intricate behaviour of diverse rocks in relation to the elastic wave travelling through them. The waves propagated from the centre of disturbance will appear on the seismograph as undulations of irregular periods, especially near the origin. At a distance waves of short period will gradually die out owing to the greater damping effect, while those of long period will still leave their mark, although not felt by us as a shock.

The investigation of the seismic waves affords the best means of feeling the pulse of the interior of the earth ; the elastic nature and the density distribution of the constituent rocks, or even the condition of the inaccessible depth, will in some future day be brought to light by the patient study of the disturbances, which traverse the strata of heterogeneous structure and appear as tremors or earthquakes on the earth's surface. I think the introduction of the horizontal pendulum is a great progress in that branch of study which relates to the earth's interior, not that it records the apparent surface-movement of the soil, but that it does not fail to record earthquakes of distant origin, which, though insensible to us, sometimes appear as slow waves of gigantic

amplitude. By it will be found disturbances which come through various strata, and probably those travelling through the stratum of maximum velocity of propagation.

Seismic waves travelling through strata of heterogeneous elasticity and density will generally be not purely longitudinal as in the case of sound, nor purely transversal as in the case of light, but a mixture of these two kinds. The velocity of propagation expressed as a function of elastic constants and density is not a simple problem; and moreover we do not possess sufficient experimental data to test the result

of calculation. The formula $V_l = \sqrt{\frac{E}{\rho}}$ for longitudinal waves in a thin rod will give a rough estimate of the velocity.

From records taken in Italy and Japan, Prof. Omori concludes that the velocity of the first tremor is almost always equal to 13 kilometres per sec. The question naturally arises: how can we account for such an enormous rate of propagation? The velocity of plane longitudinal waves in an infinite medium of steel is about 6.2 kilometres per second; if we take a rod of steel in place of an uniform medium and give a blow to one of its ends, the longitudinal wave will travel with a velocity of 5.3 kilometres; if the same experiment be repeated on a piece of iron pyrites cut parallel to its axis of greatest elasticity, the velocity will be 8.4 kil. per second; in topaz, it will amount to 9 kilometres. Thus even with substances easily accessible on the earth's surface, we have instances of elastic waves travelling with a velocity of something like 10 kilometres. In the present experiments the velocity in several primeval rocks ranges from 6 to 7 kil. per second; as we go deeper in the crust, we may not fail to find those rocks whose elastic constants are several times greater than those near the surface. So far as I am aware, iron pyrites has the greatest modulus of elasticity among the substances which have till now been placed under experimental test; it is about 1.6 times greater than in steel, and amounts to 3.5×10^{12} c.g.s. units (Voigt). If we now imagine a stratum in which Young's modulus exceeds that of iron pyrites as much as that of iron pyrites exceeds that of steel, we shall obtain a velocity arrived at by seismologists, if density is not at the same time increased so much as to bring down the rate of propagation. The velocity of 13 kilometres per second, which is that calculated from the preliminary tremors, roughly corresponds to $E = 6.0 \times 10^{12}$ and $\rho = 3.5$. To speak of the relation between density and elastic constant might seem a little absurd, but in the rocks so far examined,

a certain relation between these two physical constants seems to exist. Comparing the elastic constants of caenozoic and archæan rocks, we find that with the increase of density from 2 to 3, the modulus of elasticity has increased more than ten times in certain specimens. Thus it would not be a wild conjecture to put $E = 6 \times 10^{12}$ when the density is 3.5. As the mean density of the earth is little over 5.5, we shall come across a stratum of the density above cited not very far from the surface. These considerations give support to the view above stated that there is a stratum of maximum velocity of propagation.

From the minute study of the records of distant earthquakes, Prof. Omori found that in the intermediate position between the first tremor and the principal shock, there is almost always a slight abrupt change in the seismograph record. The velocity of propagation for this kind of disturbance is about 7 kilometres per second. If we suppose that the interior of the earth consists of an isotropic substance, and that the longitudinal wave travelling through it gives rise to the first tremor, and the transversal to the second, we can easily find the Poisson ratio of the hypothetical interior. Obviously

$$\sqrt{\frac{\lambda + 2\mu}{\mu}} = \frac{13}{7},$$

and the ratio of lateral contraction to longitudinal extension

$$\sigma = \frac{\lambda}{2(\lambda + \mu)} = 0.298.$$

This value is nearly the same as that generally attributed to iron, glass, and other isotropic substances. In his paper on the Application of Physics and Mathematics to Seismology (Phil. Mag. 1897), Dr. Chree supposes that the velocity of 12.5 kilometres belongs to the longitudinal wave, that of 2.5 to the transversal, and adduces proof that the substance in the interior of the earth offers enormous resistance to compression. On the above supposition, Young's modulus turns out to be 100×10^{10} c.g.s. units, which is less than that observed on chlorite schist. It seems quite unlikely that the elastic constants of the deeply-seated material should be less than those within a few thousand feet of the earth's crust. In addition to this, we have to remark that the disturbance whose velocity is greater than 10 kilometres is very small compared to that of the principal shock, which is generally 3 kilometres; and we have no ground to suppose that the effect of the transversal wave is greater than that of the longitudinal. On the hypothesis that the interior of the earth consists of homo-

geneous substance, as Dr. Wiechert assumes it to be, it is quite probable that the velocity of the longitudinal wave is 13 kilometres, and that of the transversal wave is about 7 kilometres, as found by Prof. Omori. These velocities are nearly twice as great as those observed in the oldest rocks here examined.

Elastic waves travel with slow velocity in surface rocks. If the principal shocks in the seismometer-record be taken into account, the velocity turns out to be very small and about 3.3 kilometres. This evidently is about the mean velocity of propagation in most of the surface rocks, and shows that waves of large amplitude creep along the surface. It is not wonderful that with distant earthquakes, the duration sometimes extends over several hours, as the disturbance travels through strata of different elastic constants, and the waves modified in various ways will appear all blended together on the seismograph. Although 3 kilometres may be a mean velocity, there are certain surface rocks in which the velocity is less than a kilometre. The shock at the epicentre may last only for a short time, but the duration at a distance will be lengthened, as the range of velocity is very wide. The disturbance coming from the strata of greatest rate of propagation will first make its appearance at the beginning of the preliminary tremor, followed by waves travelling with slower velocity till the principal shock arrives as surface waves. It will be followed by waves travelling with still slower velocity leaving faint record on the seismograph, till they at length fade away. Neglecting the time of passage from the stratum above mentioned to the surface, it is natural to expect that the duration of the so-called preliminary tremor preceding the earthquake shock increases *linearly* with the distance of the epicentre from the place of observation. The above relation was established from various earthquakes which happened in Japan, recorded by Prof. Omori.

With great earthquakes which are perceptible on a seismograph at very great distances, the duration will continually increase with distance; the disturbance may sometimes propagate still unabated in one or other direction round the earth. If the last-mentioned case actually takes place, the tremor will probably last even for days. As such records have sometimes been obtained by seismologists, it may not be out of place here to notice the possibility for such undulatory movement of the ground.

In conclusion, I wish to express my thanks to Prof. Koto and Mr. Fukuchi for valuable information concerning the geological and petrological character of rocks examined in the present experiment.

V. *On the Strength of Ductile Materials under Combined Stress.* By JAMES J. GUEST*.

CONTENTS OF ARTICLES.

1. Lack of knowledge of laws of strength.
2. Separation of the isotropic materials into ductile and brittle.
3. The yield-point in Tension Tests.
4. The yield-point, rather than the ultimate, stress the criterion of strength.
5. Variations of the ultimate and yield-point stresses : annealing.
6. The elastic limit.
7. The elastic-limit effect probably due to the existence of local yield-points.
8. The yield-point, in preference to the elastic limit, selected as the criterion of strength.
9. Torsion a case of combined stress.
10. First reason for use of thin tubes as specimens.
11. Results of previous torsion experiments.
12. Previous experiments upon the yield-point under combined stress.
13. Experiments upon ultimate strength under combined stress.
14. Theories of elastic strength under combined stress : the maximum stress theory.
15. The maximum strain theory.
16. Theorem upon the limiting values of σ .
17. The maximum strain theory not disproved by published experiments.
18. The maximum shearing-stress criterion of elastic strength.
19. Further reasons for adopting thin tubes as specimens.
20. Range of stress covered by different types of experiment.
21. Method of checking the isotropism of the material as regards yield-point stresses.
22. Objections to tubes on account of want of isotropy.
23. Objections to tubes on account of large effect of defects.
24. The system of Tests.
25. The specimens and holders.
26. The tension loads.
27. The application of torque.
28. The friction of the torsion-rigging.
29. The application of the internal pressure.
30. Measurement of the fluid pressure.
31. A new type of pressure-gauge.
32. Measurement of the distortions.
33. A new Extensometer.
34. Errors of extensometer.
35. A new twist-measuring apparatus.
36. Proof that the torsion-mirrors measure the twist.
37. Effect of bending.
38. As a transmission dynamometer.
39. The diametral extensometer.
40. Method of making the Tests.
41. The determination of the sectional area and thickness of the tubes.
42. Calculation of the stresses.
43. Calculation of the strains.
44. Maximum shear and slide are proportional.

* Communicated by the Physical Society : read May 25th, 1900.

45. Quantities tabulated.
46. Results of the experiments—the tests on solid bars.
47. The material and shape of tubes satisfactory.
48. The elastic limit phenomenon.
49. Yield-point stresses of the same type nearly constant throughout series on each tube.
50. The variation of the maximum stress.
51. The variation of the maximum principal strain.
52. The maximum shearing-stress or slide nearly constant.
53. Graphical presentation of variations.
54. Conclusions probable for general type of stress.
55. Effect of a volumetric stress (steel).
56. Convenient view of general type of stress.
57. The copper and brass tests, and diagrams.
58. Practical conclusions and note.

1. **L**ACK of knowledge of the Laws of Strength.—From the point of view of both pure and applied science, it would be of interest to know the complete laws of the strength of materials; but although a multitude of tests have been made in certain simple modes, our knowledge of the laws of strength has been extended by few experiments exposing the material to two or more principal stresses, and thus, except in the simpler cases, the elastician is without experimental guidance as to what he should seek analytically as determining the strength of the body under consideration.

In the series of experiments herein described the materials employed have been subjected to a certain variety of simultaneous principal stresses; and the results are recorded in the hope that they will prove of service to elasticians and engineers.

The simplest, and most primitive, method of ascertaining the strength of a material is to subject a cylindrical specimen of it to a direct tension or compression, and to increase the force until the specimen breaks or collapses; the breaking-stress, thus found, being taken as the basis for calculations of the strength of all pieces of that material used in structures or machines.

As material is frequently exposed to torsion, another frequently employed test is to break a circular cylinder of material by the application of a torque, the stress so found being used in calculations for shafts, &c.

2. *Separation of the Isotropic Materials into Ductile and Brittle.*—A consideration of the form of the fractured surface in the various types of test affords some suggestions. In the case of ductile materials such as iron and steel (structural) broken by tension, the material draws out at the point of rupture and the surfaces of fracture, plane or conical, are partly or entirely inclined to the axis of the specimen at about 45°. If, however, cast iron be broken in tension, there

is no evidence of drawing out, and the fracture is practically normal to the axis of the specimen. When ductile specimens are broken in torsion, the surfaces of rupture are normal to the axis; but in the case of cast iron the surface of rupture takes a curious form, one of the edges of the fracture of a circular cylindrical specimen being a helix whose angle is about 45° . Some steels of a treacherous nature exhibit a fracture partaking of the two types, part of it being normal to the axis, but part extending along the length of the specimen and having the helical edge. Under compression ductile materials ultimately give way by lateral flow; cast-iron specimens exhibit rupture-surfaces inclined to the axis at about 30° .

It will be noticed that in all cases the ductile materials exhibit rupture-surfaces coincident to a large extent with the surfaces of maximum shearing-stress, suggesting that the final action in such cases partakes of the nature of a viscous flow. Cast iron, however, under tension and torsion fractures along the surfaces across which the tension or elongation is greatest; in compression it appears to fail by a shearing action, influenced perhaps by the friction of the crystals.

These illustrations of modes of fracture tend to show that a sharp line of demarcation may be drawn between the behaviour under stress of ductile and other materials, and this in spite of the gradual transition from one stage to the other in manufacture and in use.

Owing to the increasing tendency to substitute steel for cast iron in structures and machines, the ductile materials were selected as the subject of experiment; steel of four grades, copper, and brass have been experimented upon.

3. *The Yield-point in Tension Tests.*—Upon observing the operation of testing more carefully and taking measurements of the extension at frequent intervals, we notice that under the lower loads the specimen stretches so very slightly as hardly to affect the beam of the testing-machine. This continues until we reach a point called the yield-point, marked by a large extension of the specimen for a slight increase of load, the lever of the testing-machine in consequence moving considerably. At the same time the scale, if there is any, on the specimen peels off, starting by cracks inclined at about 45° to the generating-lines, separating the scale into squares; or if the specimen be machined, certain characteristic changes take place upon its surface. After some time the stretching under this load ceases and the load on the specimen can be increased, the elongation also increasing until rupture takes place. The loads and the measurements of the extension they pro-

Fig. 1. Typical Stress-Strain Curves.
 2. Testing Apparatus.
 3. New Pressure Gauge.

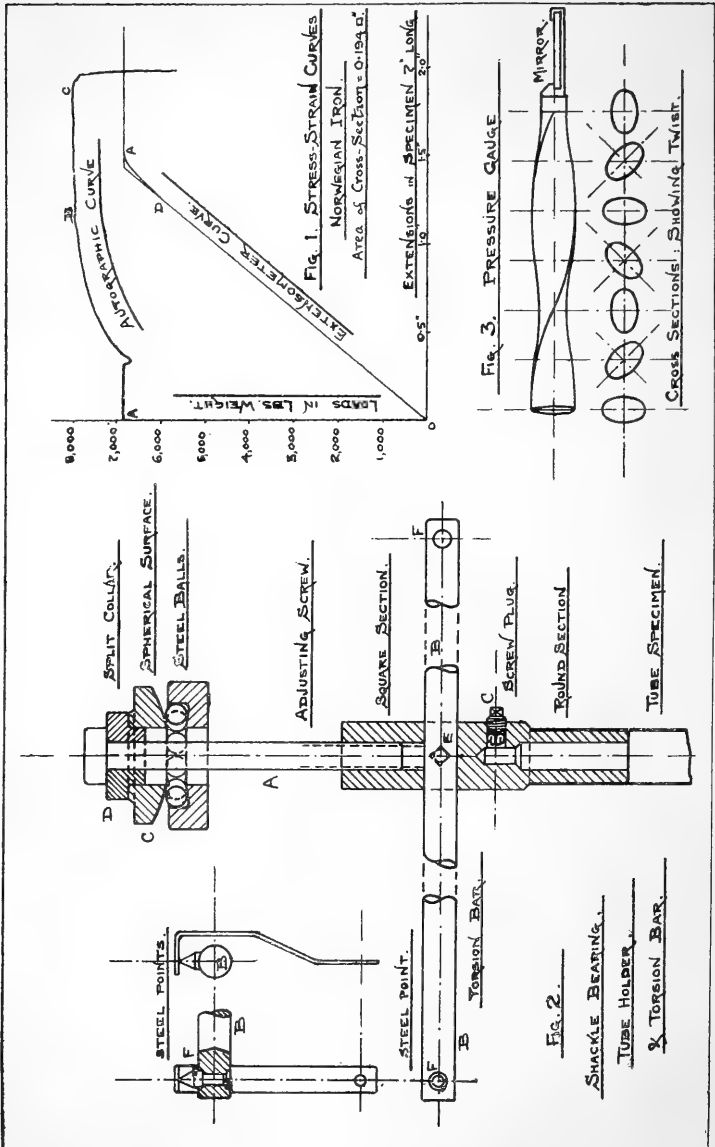

duce may be plotted into a curve of which an example is shown in fig. 1, which is reproduced from a diagram (for Swedish iron) drawn automatically by a Wicksteed testing-machine, the ordinates being loads and the abscissæ actual extensions in an original length of 7 inches. Up to the yield-point the extension is very small, being about one-thousandth part of the length of the specimen; the final elongation, however, was in this case 29 per cent. of the original length.

4. *The Yield-point, rather than the ultimate, Stress the criterion of strength.*—A closer examination into the relation of the stress and strain below the yield-point shows that they are proportional to one another (Hooke's law), and it is upon this proportionality, or rather upon a generalization of which the above is a special case, that the theory of elasticity is based. Now if over any portion of a body the yield-point of the material is exceeded, the basis of our calculations is vitiated, and the redistribution of stress and strain may be widely different from the proposed distribution and lead to immediate failure. For this reason the yield-point, rather than the breaking, strength should be taken as the criterion of the strength of a ductile material in simple tension.

Further arguments to the same effect arise from Wöhler's experiments, in which he showed that the frequent repetition of a stress slightly exceeding the yield-point stress will finally cause rupture. The yield-point as the criterion of strength is so far accepted in modern practice, that most specifications of steel now call for a yield-point not lower than one half the ultimate strength.

5. *Variations of the Ultimate and Yield-point Stresses: Annealing.*—Neither the ultimate nor the yield-point stress for a material is quite definite. For the former, besides depending upon the taking account of, or the neglect of, the reduction of area due to drawing out, is affected by the rate of application of the load; in fact, the phenomena displayed by ductile materials under stresses approaching their ultimate value are rather the dynamics of a semiviscous fluid than the statics of an elastic body. And the yield-point is affected by mechanical treatment.

If in a tension test, after the stress-strain curve has begun to rise after passing the yield-point, the load be removed, the specimen is to all appearance unchanged. Let it, however, be regarded as a new specimen and be tested: it will exhibit a yield-point close to the greatest stress previously applied to it; but a continuance of the test will show that its capability of extension has been diminished. Such false yield-points,

due to stresses or mechanical treatment, can be removed by annealing, which is generally considered to render the material isotropic.

6. *The Elastic Limit.*—It would so far appear that the yield-point is a definitely defined point with the material in its normal condition, but a closer examination of the phenomena involved brings to light a difficulty in its accurate determination. In addition to the autographic curve in fig. 1, a highly magnified edition of the same curve is shown, the points on this curve being obtained by the use of an extensometer; the curve is referred to as the "extensometer curve." At some point D in the extensometer curve (fig. 1), before the yield-point A, the stress-strain curve for the material ceases to be a straight line, and at the same point a time-effect manifests itself, the material yielding a little for some time after the application of the load. This time-effect renders the value of the strain just as the yield-point is reached a somewhat vague quantity; it, however, does not very materially affect the determination of the stress at the yield-point. The point at which this deviation of the straight line and time-effect appears is usually known as the elastic limit. I shall refer to the effect of time upon the strain and to the deviation of the stress-strain curve from linearity as the elastic-limit effect.

7. *The Elastic-limit effect due to the existence of Local Yield-points.*—This phenomenon may be one *sui generis*, but, partly as the departure from the straight line and the manifestation of the time-effect are simultaneous, I am inclined to think that it is due to local variations in the material, which partly by disturbing the uniform distribution of stress and strain in their neighbourhood, and partly by their nature, result in small volumes of the material reaching the yield-point prematurely, and so cause the specimen as a whole to exhibit a foreshadowing of the yield-point phenomena. On this supposition, if a specimen be once strained, as a whole, up to or beyond the yield-point, at the locations which give rise to the elastic-limit effect, the strain would be carried well beyond the yield-point; and if the load were removed, on a subsequent test they would contribute no time-effect until their new yield-point was reached, which would occur simultaneously with the yield-point of the whole specimen; hence a specimen would display no elastic-limit effect, or at any rate a very much reduced one, on a second testing. This agrees with experiment, and illustrations of it will be pointed out later. (See figs. 16, 17, & 18.)

Furthermore, although the effect is removed from a par-

ticular kind of test, it is unaffected, or even increased, for tests involving the application of stresses of a different type; examples of this may be seen in figs. 16 & 18, in which a tension and a torsion test respectively upon the material are compared, the material in the interval of the two tests having been subjected to yield-point stresses of a different type.

Not very many years ago the existence of the yield-point was not recognized, the stress-strain curve sketched as normal showing a gradual bend over (somewhat similar to the copper tension tests shown in figs. 21-24). This would be the case with imperfect material, the portions of the material in the neighbourhood of flaws and variations reaching the yield-point successively, and so masking the phenomena. There is no doubt that the materials of construction as produced to-day are much more uniform and free from defects than those of a quarter of a century ago, and thus can display phenomena perhaps hidden in the past by their imperfections.

It should be noted that the same effect (elastic-limit effect) on the stress-strain curve is caused by the non-coincidence of the axis of the specimen with the load-line.

8. *The Yield-point, in preference to the Elastic limit, selected as the criterion of strength.*—The elastic-limit effect may then be merely due to local yielding, and taking this view of it I have regarded the yield-point as the true criterion of the strength of the material, and sometimes have assumed that Hooke's law held up to it.

In all those of the experiments of this series which were made upon steel, a yield-point, sometimes much obscured by elastic-limit phenomena, was sought for and determined; and evidence will be given to show that, although there is on the whole a slight tendency for an annealed specimen, when frequently stressed, to have its yield-point rise, yet, if the material be not much strained at the yield-points, this rise is not very large, especially if the type of stress be varied. In the case of copper, the curves obtained were such as to make it difficult to determine the yield-point, if indeed one exists; several of the curves, however, have been plotted out so that the range of choice may be appreciated.

9. *Torsion, a case of Combined Stress.*—The case of torsion presents a case of combined stresses, two principal stresses being equal in amount but opposite in sign, while the third is zero. Of such tests a large number have been made on round bars, but the essentials of the phenomena involved are masked by the variation of strain from the axis outwards, which causes the outer layers to reach the yield-point first, and so produce effects corresponding to the explanation above

given of the elastic-limit effect in simple tension. As any defects in the material will contribute their effect, the result is that it is practically impossible to select the yield-point, or to determine with any degree of precision the point where the curve first deviates from the straight line.

10. *First reason for use of Thin Tubes as specimens.*—To avoid this masking of the phenomena, I conducted my experiments upon thin tubes, the walls of which were from $\frac{1}{20}$ to $\frac{1}{25}$ of the radius in thickness. I also tested two solid bars, more to ascertain, from the agreement of the elastic constants with their known values, that no large mistake had been made in the measurement of the parts of the apparatus. An inspection of the torsion stress-strain, or rather torque-twist curves (fig. 15), for these bars will show the practical impossibility of locating the yield-point (or the elastic-limit, if it be a true phenomenon), particularly if we bear in mind Mr. Love's theorem that a small round flaw will double the shearing-stress in its neighbourhood, which if the flaw were near the surface would produce the elastic-limit effect at about half the true yield-point torque.

11. *Results of previous Torsion Experiments.*—Published results of torsion experiments (see Unwin, 'Machine Design,' vol. i.) make the elastic strength of iron and bronze in torsion to be from 0.625 to 0.735 of the strength in tension: for copper the ratio is about 0.545. The ratio of the ultimate strengths is a little higher. The ultimate strength in torsion should be determined by the use of the formula $T = \frac{2}{3}\pi gr^3$, which considers the whole of the material across a normal section to be in the same state of stress, but as the employment of this formula is not universal, the ratio of the ultimate stresses is open to suspicion.

12. *Previous experiments upon the Yield-point under Combined Stress.*—Beyond the numerous experiments upon torsion, the only experiments upon the yield-point which I have been able to find are those made upon pianoforte-wire by Mr. McFarlane for Lord Kelvin's article upon Elasticity in the *Encyclopædia Britannica*. These showed that a simultaneous tension lowered the yield-point in torsion, but numerical data are not given. Lord Kelvin concludes that as a tension lowers the torsional yield-point, a compression would raise it; but his argument does not appear to be rigorous, and I venture to think that either tension or compression would lower it.

13. *Experiments upon Ultimate Strength under Combined Stress.*—Of experiments upon the ultimate strength under combined stress, there are the well-known experiments of

Tresca, which show that a ductile material eventually behaves like a very viscous fluid, and a few experiments performed by Messrs. W. Voigt and L. Januskiewicz on wax rods subjected to tension only, and to tension and external fluid pressure (compressed air) combined. In the latter case it was found that at rupture the shearing-stress in the material was the same in the two cases, thus agreeing with Tresca's experiments upon metals.

14. *Theories of Elastic Strength under Combined Stress: the Maximum Stress Theory.*—As examples of combined stress continually arise in practice, some working theory as to the criterion of strength, preferably elastic strength, must be assumed and adopted. Two theories hold the field to-day. The first is the assumption, it can hardly be called by any more ambitious name, that the material yields when one of the principal stresses reaches a certain amount, which must, by taking a special case, be the stress determined by a simple tension experiment. This was the theory adopted, in the absence of experimental data, by Rankine, and it is the one used by English and American engineers.

As all experiments upon torsion give results at wide variance with this theory, it can hardly be considered to be correct; and if it is used, a different working stress should be adopted in cases of torsion or systems of stress approximating thereto.

15. *The Maximum Strain Theory.*—The second theory is that the material yields when the greatest strain reaches a certain amount, which must, taking a special case, be the yield-point strain in simple tension. This theory was first advocated by St. Venant as fitting in with that molecular theory which leads to the uniconstant theory of elasticity. Upon this theory the value of Poisson's ratio, or the ratio of lateral contraction to axial extension of a specimen under simple tension, is 0.25; upholders of the theory maintaining that variations from this value which experiment exhibits are due to imperfections of the material. The greatest-strain theory is that adopted upon the Continent, and is strongly upheld by many elasticians.

16. *Theorem upon the Limiting Values of σ .*—In the case of a cube of elastic material, whose elastic constants are E and σ (E being Young's modulus, or the ratio of stress to strain in a simple tension test), subjected to a uniform fluid pressure p , the linear contraction is $\frac{p}{E}(1-2\sigma)$. If the constitution of the material is to be stable, this must be a positive quantity, and hence the maximum value of σ is 0.5. This also shows that an isotropic stable material cannot decrease in

volume under a simple tension (else it would decrease volumetrically under three orthogonal tensions).

It is hardly conceivable that σ should be negative, but it cannot be less than -1 ; otherwise the material would be unstable under torsion as the energy of a simple shear, $\frac{p^2}{E}(1 + \sigma)$, would be negative should $1 + \sigma$ be negative.

The values of σ met with in the course of experiments undertaken will be found in Table V. They are not determined by a method possessing much accuracy, being found from the values of E and C ; they are, however, sufficiently accurate for the purpose in view.

17. *The Maximum Strain Theory not disproved by published experiments.*—Upon the maximum strain theory of strength the yield-point stress under torsion to that under tension should be 0.80 for cases in which $\sigma = 0.25$. The least value of this ratio will occur when σ is a maximum, *i.e.* when $\sigma = 0.5$, the value then being 0.66 . As the experimental results quoted above place this ratio, for steel, between 0.625 and 0.735 , it will be seen that, taking into consideration the effect of flaws upon a torsion test and the difficulty of locating the yield-point, the experimental results cannot be held to disprove the theory, although they militate against it.

In discussing the phenomena of torsion, Tresca separates the state of the material into three stages: the elastic state, the plastic stage, and an intermediate condition. These correspond to the portions OA , BC , and AB respectively in a stress-strain curve such as fig. 1. St. Venant, followed by many elasticians, does not recognize the intermediate stage, and considers that Hooke's law holds up to the point at which plasticity begins; he adopts Tresca's results that in the plastic stage the shearing-force is constant, and upholds a specific maximum strain as the condition of limiting elasticity.

I fail to understand how a material could have one condition for the commencement of plasticity and an entirely different one for its existence; perhaps users of these conditions tacitly admit the existence of the intermediate stage, but neglect it for the simplification of calculation and because the physical difference between the elastic and plastic states is so great; or perchance they do not admit the rigour of the deduction of the plastic law from Tresca's experiments. [St. Venant's proof (*Comptes Rendus*, lxx., and Todh. & Pearson's 'History of Elasticity,' vol. ii. § 236) that in the plastic stage the resistances to slide (shearing-strain) and elongation have the same value, consists in equating the work done in similar changes under a simple shear q and a com-

bined stress $+p$ and $-p$, and hence showing that $q=p$. This is true in the elastic as well as in the plastic stage; but the combined stress $+p$ and $-p$ is merely another view of the shear, and constitutes a very different condition to a simple tensional stress, so that St. Venant's final step seems illogical.]

18. *The Maximum Shearing-Stress criterion of Elastic Strength.*—A third theory of elastic strength, mentioned by Cotterill in his 'Applied Mechanics,' is that the condition of yielding is the existence of a shearing-stress of a specific amount. Having regard to the behaviour of the material when in the plastic stage, the assumption of continuity would lead to this theory, but although the shearing-stress law of the plastic stage has been generally recognized, no formulas for elastic strength in particular cases have been based upon a similar law for the yield-point. The knowledge of Tresca's results and the observation of the phenomena presented by cold bending, tension and compression tests, punching, and the general manipulation of metal, must have urged many towards the conclusion that this is the true criterion of elastic strength in a ductile material.

19. *Further reasons for adopting Thin Tubes as specimens.*—It has been stated above, that tubular specimens were used in this series of experiments. In addition to the reason there advanced, I was influenced by the advantage which tests made by subjecting the tubes to internal fluid-pressure would have in confirming, or not, the various theories. In such tests it is evidently an advantage to have the thickness of the tube small compared with the radius, as the stress will be more uniform, and the yield-point in consequence more sharply defined.

20. *Range of Stress covered by different types of experiment.*—If a specimen of circular section be submitted to torsion and tension combined in various ratios, the stresses at the exterior may be made to have all combinations between the pairs $-p$, $+p$, and 0 , $+p$ [throughout I have considered tensions and elongations as positive, owing to their more frequent occurrence]; and if compression were substituted for tension the range between $-p$, $+p$, and $-p$, 0 would be included. Nothing beyond these, *i.e.* no like principal stresses can be produced by this method; these, however, can be readily impressed on the material of a hollow cylinder by the use of fluid pressure. By the combination of tension with internal pressure we can extend the range from 0 , $+p$, to $+p$, $+p$; and by combining external pressure and axial force the range from $-p$, 0 to $-p$, $-p$ could be covered, but owing to the probable instability of a tube of suitable dimensions

under these conditions, experiments upon this part of the range were deferred.

21. *Method of checking the Isotropism of the Material as regards Yield-point Stresses.*—This, however, is not the only advantage of the internal pressure and tension tests, for by their use we can check the isotropism of the material within the range $+\frac{1}{2}p$, p , by having the greater of the stresses first parallel to the axis and then circumferential: to do this within the range 0, $+\frac{1}{2}p$ it would be necessary to use a compressive load and internal pressure, as the longitudinal stress due to the internal pressure must be added to the longitudinal stress due to the externally applied load.

In addition, tests under the combination of internal pressure and torsion permit the principal axes of the stress to be inclined at varying angles to the generating lines of the specimen, and also, if a practical amount of isotropism has already been demonstrated by the internal pressure and tension tests, afford a check upon the general accuracy of the work by comparing the results of these tests with the results of experiments involving similar stresses differently applied.

Torsion tests on thin tubes, it may be noticed, cause a tendency in the wall to buckle, while the internal-pressure and tension tests do not. No buckling occurred in the experiments.

Although combined stresses may be produced by simpler methods, such as the loading of a cranked shaft or of a helical spring, such methods, since a small portion only of the material is carried to the yield-point condition, are hardly likely to furnish decisive results. It is essential for definition, both because of the elastic-limit effect and because of the smallness of the elastic strain, that the whole of the material directly under observation should be similarly stressed. The simplest methods of attaining this appeared to me to be those indicated above, namely, the application of axial loads, torques and internal pressures, singly or in pairs, to thin-walled circular tubes. As the production of thin-walled specimens otherwise than by drawing would be difficult, I determined to use seamless drawn tubing as specimens, and to remove the state of set left by the operation of drawing by annealing.

22. *Objections to Tubes on account of want of Isotropy.*—It has frequently been urged that no such material as wires, tubing, or sheet-metal can be regarded as isotropic; but I think such criticism may fairly be met by the consideration that in the production of ductile materials, operations producing sets and internal stresses, afterwards removed by annealing, are

invariable and essential to the manufacture of a uniform material, and that annealing seems usually to remove this state of set. In the results of the tests shown, it will appear, at any rate so far as the occurrence of the yield-point was concerned, that the materials were practically isotropic.

In the case of experiments upon wires, which after annealing show a marked want of isotropy, it is probably due to overdrawing in the manufacture of the wire, which produces a series of conical defects along the wire, the effect of which evidently could not be removed by annealing. Unless the wire is wanted particularly hard for some special purpose, this defect is not likely to occur.

23. *Objection to Tubes on account of large effect of defects.*—Another objection, which can well be raised to the use of such thin-walled tubes as those which I experimented upon, is the large effect which would be produced by variations and defects in the specimen, especially in the torsion experiments. The tubes were all carefully examined before use, and none showing visible defects were employed; the greatest variation in external diameter was about 0.005 inch in 1.25 inch. This examination was intended, however, merely to avoid the waste of time which the testing of an obviously poor specimen would involve.

If any flaw existed in the material, or if the surfaces were not close approximations to concentric circular cylinders, the values of the elastic constants would be considerably changed, and always to a lower value; the density of the material would be low; and the stress-strain curve would soon cease to be straight.

Now in all the tests measurements of the distortions produced, as well as of the forces applied, were taken. The moduli of rigidity and extension calculated from these were never found to be widely different from their customary value, and especially they are never low in value. (See Table I.) Also the densities found were high. Furthermore, the stress-strain curves to within a point not far below the yield-point were always found to be straight.

24. *The System of Tests.*—The method of experimenting employed was, then, to subject the tubes to torque, to torque and tension combined, to tension only, to tension and internal pressure combined, to torsion and internal pressure combined, and to internal pressure only; and to take measurements of the axial elongation, of the twist when torque was employed, and in some cases of the circumferential strain. The range of the two principal stresses thus covered was from $-p$, $+p$ to $+p$, $+p$, the third principal stress being small, or zero.

25. *The Specimens and Holders.*—The specimens upon which the tests were made were formed of tubes (steel, copper, and brass) soldered on to holders, which served conveniently to apply the tension loads and the torques, and to introduce fluid under pressure to the interior of the tube. A convenient size of tube appeared to be $1\frac{1}{4}$ in. diameter, with the walls from 0.025 in. to 0.036 in. in thickness. All measurements of extension and twist were made upon the same length of 8 in., but in order to provide room for the diametral extensometer which was sometimes used, and to avoid the disturbing effects of the holders upon the distribution of stress and strain, the length of tube free from the holders was a foot. A holder is shown in fig. 2. A is a screw connecting the holder to the jaw of the testing machine, it is adjusted so that the forces applying the torque have no vertical component—the specimen being vertical. B is a cross-bar serving to apply or to resist the torque. C is a passage-way for the oil used to apply the internal pressure. In the upper holder, which was the nearer to the weighing part of the testing machine, the exit was closed by a screwed cap; sometimes a piece of rubber tubing, doubled over itself to form a packing, was pushed in ahead of the closing plug, and proved to be a very efficient means of preventing leakage. The exit was not closed until fluid appeared at it, in the expectation that should a tube prove unsound, or the pressure get beyond control, no damage would then be done to the strain-measuring apparatus. The lower holder was identical with the upper one, except that, in the place of the plug, a pipe was brazed into it, there being a coupling at the further end of the pipe for connexion with the pressure system.

26. *The Tension Loads.*—The tension loads were applied to the specimen by means of a Ten-ton Wickstead machine of the screw type. The shackles of the machine were fitted with the ball-thrust, or perhaps pull, bearings shown in fig. 2. The “male cone” surfaces C were made spherical in order that the specimen could line itself up to some extent and cause the axes of pull and of the specimen to coincide, and yet allow the specimen freedom to rotate. This action was assisted by gently tapping the specimen at low loads. The method of holding the specimen was by means of split collars D, the screw A of the tube-holder being thrust through the spherical cone of the ball-bearing so far as to allow the collars to be placed round it and inserted into the spherical cone. This proved a rapid and easy method of firmly securing the specimens. I possessed no conveniences for calibrating the testing machine by the direct application of a large dead

load, but the travelling poise (500 lbs.) was removed and found to be correct, and the distance between the knife-edges was measured, with the same result. In a few of the tests there was evidence that the axes of the specimen and of the pull did not exactly coincide, causing a small bending moment on the specimen. This tends to produce an effect similar to that of the elastic limit.

27. *The Application of the Torque.*—In order to apply torque to the specimen, it was placed in the testing machine and a small load (250 lbs.) placed upon it, to line it up and steady it. The cross-bars were then placed in the holders and nipped in position by the set screws E. Steel points F were then placed in the upper cross-bar, and a pair of screws in a bracket, bolted to the casting of the testing machine, were adjusted to just touch the lower cross-bar. Finally, equal and opposite forces were applied to the steel points by means of bent pieces of iron, as shown in the left-hand top corner of fig. 2, attached to belts. These belts were belt laces, which being thin, flexible, and sufficiently strong, appeared to be the best means of transmitting round pulleys such forces as were required. The belts led off horizontally from the ends of the cross-bar, which was adjusted vertically by the screw A of the tube-holders, to pulleys, from which they went vertically downwards to knife-edges fixed in the ends of a horizontal cross lever, from a knife-edge at the centre of which hung the carrier for the weights which produced the torque. The effect of the cross lever and weight-carrier was neutralized by balance-weights hung over the pulleys. These pulleys were made by filling the rims of bicycle wheels with plaster-of-paris, and, before the plaster had set hard, rotating the wheel in contact with a former, thus producing a suitable groove true with the axis of rotation. The torque thus applied to the specimen was practically pure, and produced no bending moment on the specimen. It was resisted by the forces produced by the set screws on the lower cross-bar, there being thus little or no sideways force at the lower grip.

28. *The Friction of the Torsion Rigging.*—A fourth pulley was used in testing the friction of the torsion apparatus. The greater part of this friction, when any considerable load was on the specimen, occurred in the ball-bearings in the shackles. To ascertain the friction two equal and opposite torques were applied to the top cross-bar by means of belts leading over each of four pulleys and terminating in a weight-carrier. The lower cross-bar was removed. The desired tension load P was then placed upon the specimen, and

approximately equal additional weights placed upon a diagonally opposite pair of weight-carriers until they descended. The equal additional weights were placed upon the other pair of weight-carriers until they in turn descended. The latter pair of additional weights (shot) were then placed together and weighed. One quarter of this amount for one of the weights on the carriers represents the equivalent of the friction of the system under the load P . Now in this test four pulleys and the two shackle-bearings rotate, while in the actual tests three pulleys and one shackle-bearing are rotated, thus the previous result should be halved for application to the tests. The two weights on the carriers are, however, combined into one hung at the centre of the cross-lever, so that one quarter of the weighed amount should be taken for the weight (W) at the centre of the cross-lever. The results of these friction tests are given in Table I.; the friction given is in all cases too high, as, the masses moved being large, a small moving force produced a small acceleration which required considerable time to make its effect manifest. The corrections required for W are so small that they have been neglected in the calculations of the stresses.

TABLE I.
Friction of Torsion Apparatus.

It was found that the friction of the pulleys was so small as to be negligible in comparison with the friction of the pull-bearings, the value of W making little difference.

Mean values of δW from several experiments are given:—

P	1000	2000	3000	4000
δW	0.319	0.576	0.909	1.058

Hence $\delta W = 0.285$ lb. per 1000 lb. value of P .

And $\delta W = 0.075$ lb. in all cases for the wheels.

Hence Friction only amounts to $1\frac{1}{2}$ lb. for a load of 5000 lbs.

29. *The Application of the Internal Pressure.*—When tests involving the application of internal pressure were to be made, after a small tensional load had been placed on the specimen so as to line it up, the lower end was clamped firmly by the other screws, opposite to the first set, in the bracket (fig. 4, A). The tube brazed into the lower holder was then clamped at two points to the lower cross-bar, and finally the tube was coupled to the pressure system. The clamps were intended to prevent the production of a bending-moment on the specimen; but in spite of these precautions, and although the pipe conveying the pressure was long and

thin, evidence of a bending-moment (small, however) was evinced in some of the tests.

This could have been avoided in the tension-internal pressure tests by generating the fluid pressure in a reservoir attached to the specimen, the plunger being connected to the jaw of the testing machine, thus transmitting the pull and producing the fluid pressure at the same time. This method however, only permits of a certain ratio of fluid pressure to tensional load for a given plunger, is inapplicable to torsion-internal pressure tests, and is subject to other objections. Accordingly the former method, despite the risk incurred of an undesired bending-moment, was adopted.

Up to 1000 lbs. per sq. in. the pressure was taken from the system which worked the hydraulic straining-gear of an Emery-Festing machine; beyond that pressure a small intensifier was employed to further increase the pressure.

30. *Measurement of the Fluid Pressure.*—To measure the pressure I invented a special form of gauge, but although this proved useful for calibrating purposes, it was replaced in the tests by a large commercial gauge, which could be read by means of a telescope from the controlling-valve of the Emery pressure-system, which valve was at a considerable distance from the Wickstead machine. This commercial gauge was calibrated by comparison with the volume of air compressed into a uniform tube by the pressure and by comparison with the special gauge, the constant of which was determined at a low load by means of a Crosby gauge-tester. The air-gauge consisted of a glass tube of about 1 mm. diameter of bore and 1 metre long, sealed hermetically into a glass bulb holding about 20 c.c.; below this a tube projected downwards, and was then bent upwards for convenience in handling. The capillary tube was selected as having the most uniform bore of a large number of such tubes, and was so even as to render correction for conicallity unnecessary. The bulb of the glass apparatus was contained in a iron cylinder partially filled with mercury, to the top of which the oil of the pressure-system had access. The iron cylinder was closed with a screw plug, through which the capillary tube projected; the packing used was of the U-type. The comparison of the volume of air under pressure with the reading of the commercial gauge was conducted so slowly that the changes of volume were practically isothermal. The volume of the tube and of the bulb, and the quantity of air contained, had been carefully measured, but a large quantity of air was syphoned out by the action of the mercury; and in preference to running the risk of an unnoticeable

quantity being syphoned out, the pressure at 300 lbs. per square inch was determined by the use of a Crosby gauge-tester, so that this is the ultimate basis of the measurement of the fluid pressure.

31. *A new type of Pressure-gauge.*—The special gauge (see fig. 3) consisted of a steel tube of oval section, twisted along its axis, so that the tube had a straight axis, but the extremities of the major axes of the sections perpendicular to the tube-axis lie on a pair of helices the angle of which is about 45° to 60° . One end of the tube is coupled to the pressure-system, and the free end is sealed up and a pointer or mirror, preferably the latter, mounted upon it. On the application of internal pressure the tube untwists, and the amount of angular movement is determined by the use of a telescope and scale, or in any other manner. As the strain at any part is small, it is proportional to the pressure; but the integral twist of the mirror or pointer may be made of any magnitude we please, without exceeding the elastic limit of the metal, by simply increasing the length of the gauge-tube. As, by using a tube of suitable thickness, it is easy to keep the stresses in the steel, produced by fluid pressures up to several thousand pounds per square inch, below the yield-point, and since there is no mechanism nor friction, the gauge is at once simple and accurate. By comparing the readings of two gauges, one having thicker walls than the other, the fluid pressure corresponding to the yield-point of the lighter gauge can easily be found, as it occurs when the readings cease to be proportional. The constant of the heavy pressure-gauge may be found by comparing it with the lower gauges. Having first ascertained the permissible working pressures, a thin-walled gauge may be compared with a mercury column, and its constant thus found; this gauge may then be compared with a heavier gauge, and since the constant of the first gauge cannot alter, that of the second may be found. Thus the constants of all the gauges can be found. The axis of such a gauge-tube can evidently be coiled (as a line) and produce other desirable movements.

The gauge used in the calibration of the commercial gauge was made of tubing originally $\frac{1}{4}$ inch in diameter; it was about 8 inches long, and from my knowledge of the yield-points of thinner-walled gauges I think that its yield-point would be reached under a fluid pressure of from 4000 to 5000 lbs. per square inch.

In Table II. will be found the comparison of the commercial gauge by the two methods. They give practically the same result.

TABLE II.

Gauge Calibration : Comparison of Pressures in lbs. per sq. in., as determined by the different Gauges.

Commercial.	Air.	Special.	Commercial.	Special.
200	...	196	1100	1030
300	290	290	1200	1120
400	380	...	1300	1220
500	475	475	1400	1320
600	570	565	1500	1420
700	665	662	1600	1520
800	750	740	1700	1610
900	850	851	1800	1705
1000	...	935	1900	1795
			2000	1895

32. *Measurement of the Distortions.*—In order to determine the strains and to locate the points in the various stress-strain curves, I used instruments which I had devised with a view to these tests. They were a combined axial extensometer and twist-meter, and a diametral extensometer used to determine the circumferential strain.

As it seems to be essential that any extensometer to be used on a part of the stress-strain curve likely to involve a time-effect should be single-reading, and should not be required to be manipulated in any way to obtain a reading, optical methods were used throughout.

33. *A New Extensometer.*—It will be convenient to describe the axial portion of the apparatus first. It consists of a lever-system and a mirror; the twist of the latter, produced by an extension of the specimen in a manner similar to the Unwin extensometer, being read by a telescope and scale. The various parts are shown in fig. 4, which is a side-elevation of the whole instrument in position on a specimen, the "adjuster" being shown on the left-hand side. The piece marked 1 is called the adjuster, and serves to adjust the grips 2 and 3 correctly on the specimen, so that they are at the correct distance apart, and so that certain points in their configuration lie on the axis of the specimen. In fig. 5 is shown a view from below the grip 2 in fig. 4, and in the broken lines is shown a view of the end of the adjuster. This adjuster consists of surfaces A_1, A_2, A_3, A_4 , of which A_1 and A_3 are parts of one plane, and A_2, A_4 are parts of another intersecting it. CD and EF are portions of kinematic slides for the grips 2 and 3, the other elements of the slides being formed by the spheres c_1, c_2, d on the grip 2, and e_1, e_2, f on

Fig. 4. Extensometer, side elevation.

- 5. "
- 6. "
- 7. "
- 8. "
- 9. "

Fig. 10. Apparatus for measuring Twist.

- 11. "
- 12. "

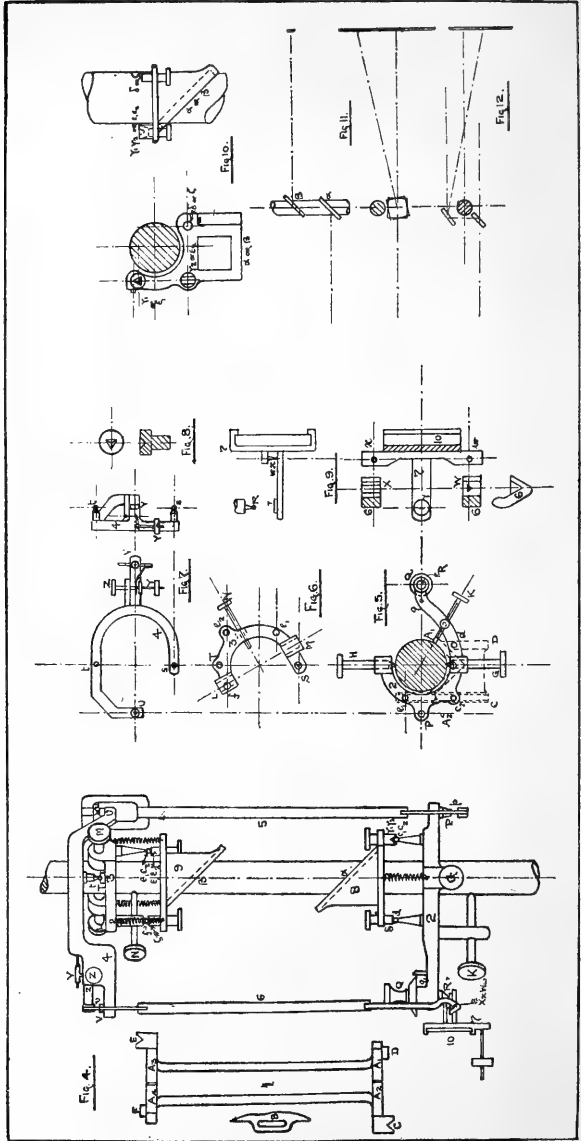

TABLE III.

Experiments to test Extensometer.

Swedish Iron specimen, previously tested; mean diam. 0.628 in.; length 8.00 in
Extensometer-reading multiplied by 0.000001265 = strain.

Load in lbs.	Extensometer-Readings.					
	In-creasing.	De-creasing.	In-creasing.	De-creasing.	In-creasing.	De-creasing.
500	043	045	...	265	...	264
1000	086	090	086	311	307	
1500	129	133	...	356	350	354
2000	172	176	171.5	399	393	
2500	215	220	...	443	437	441
3000	258	263	258	486	480	
3500	301	305	...	530	523	528
4000	344	347	344	573	566	
4500	387	390	...	616	610	613
5000	430	434	430	659	654	
5500	472	475	...	701	696	698
6000	515	516	515	743	738	
6500	558	785	781	
7000	599	826		
"	607			
710	617 &c.			
	In-creasing.	De-creasing.	In-creasing.	De-creasing.		
1800	...	-016				
1900	...	-007.5	-008			
2000	000	000.5	000			
2100	008	009				
2200	016					
3500	...	-043				
3750	...	-021	-022			
4000	...	000	-001	-002		
4250	+021	020		
4500	041			

the grip 3, which is shown in fig. 7. These are so arranged that the axis of the screws G, H, and the line *st* referred to later, will bisect the angle between the planes A₁, A₃ and A₂, A₄, and be perpendicular to their intersection. It is evident that by this arrangement the lines GH and *st* will pass through the axis of the specimen (whatever be its size), which is necessary for the determination of the mean extension should the specimen stretch unequally, owing to bending-moment or other cause. At B is shown a hole,

which is at the back of the adjuster, through which a rubber band is passed to support the adjuster on the specimen while the grips are being fastened. The spheres c_1, c_2, d of the grip 2 are placed in the V-groove C and on the plane D, and the grip slid along into position and the screws G, H nipped into the specimen; the screw R is then adjusted to touch the specimen. The other grip is adjusted in the same manner, and the adjuster is then withdrawn. It will be seen that the grips form one piece with the specimen, and during a test the screw-points are not employed as bearings, the friction at which would be an unknown variable quantity. The bottom grip 2 is fitted with a trihedral hole (see fig. 9) at P, in which lies a steel ball p fastened to the length-bar 5 (fig. 5), the pair forming a universal joint. Similar universal joints are to be seen at $Uu, Ss, Vv, Rr,$ and Ww . The length-bar connects the grip 2 with a bent lever 4 (fig. 8), which rests on the top grip 3; the length-bar being connected to the lever by the universal joint Uu , and the lever being kinematically hinged to the top grip by the universal joint Ss and a sphere t working in a V-groove T. The axis of the screws L, M intersects and bisects the line st , and the grip 2 is so adjusted that the point of intersection is on the axis of the specimen. To the other end of the lever is connected, by the universal joint Vv , the mirror-bar 6 (figs. 4 & 9), to which the mirror-frame, 7, is hinged kinematically by the universal joint Ww and the V-groove and sphere Xx . The mirror-frame 7 (figs. 4 & 7) is finally connected to the lower grip, 2, by the universal joint Rr , the sphere R being carried on the end of the calibrating-screw Q. In addition to the restraints mentioned, the mirror-bar has a wing, z , which is in contact with the (blunt) end of a screw Z, being kept in contact by the small weighted lever Y. Any extension of the specimen will result in an angular movement of the lever 4, thus raising the axis of the hinge WX, and causing the mirror to rotate about this axis. It will be noticed that the forces along all the members of the instrument are practically unaffected by the movements of the parts, being controlled by the position of the adjustable weight shown on the mirror-frame. The mirror is readily adjusted, so that the reflexion of the scale appears in the field of view of the telescope by means of the screw Z, which turns the mirror about a vertical axis, while the scale-reading can be adjusted to zero by means of the screw Q. This screw also serves, in case it should be desired to push the investigations beyond the yield-point, to readjust the reading on to the scale as often as desired, and also to

ascertain directly the value of a scale-division in terms of the axial strain. To do this the change of scale-reading caused by one or more turns of the screw, the head of which is graduated and the pitch of which is known; then, by taking account of the multiplication by the levers and of the length of the specimen, the axial strain per scale-division is easily found. The screw Q was compared directly with a Brown and Sharpe micrometer, and the two were found to agree to the $\frac{1}{10,000}$ inch in eight turns or 0.2 inch. A consideration of the behaviour of the instrument under the supposition that the specimen bends or twists will show that these do not affect the reading, which will always represent the mean axial elongation. One kinematic restraint, it will be noticed, is wanting: this, however, would be supplied by a wing attached to the length-bar and arrangements similar to YZ, but would have no effect on the working of the instrument; it is therefore omitted. Figs. 5, 6, 7, 8, and 9 represent parts of the extensometer: fig. 6 being the top grip, 7 the lever, 8 a trihedral hole, and 9 a side-view and sectional plan of the mirror and its supports, on a rather larger scale than the other parts.

The instrument proved sensitive and trustworthy; the tests of it for sensitiveness made on the Norwegian iron specimen previously referred to are given in Table IV. The scale was placed at such a distance that the extension in 8 inches corresponding to one scale-division was about the one hundred thousandth of an inch; the nearest scale-division is recorded, except when the cross-hair of the telescope was apparently midway between two divisions.

34. *Errors of Extensometer.*—In a figure formed by plotting out Table IV. it can be noticed that the hysteresis-loop, due to the yield-point having been reached previously, is well marked, and its width is considerably greater than the instrumental error; the errors, which are quite insignificant, are about the value of one scale-division, and include any error due to the want of sensibility of the testing-machine.

35. *A New Twist-measuring Apparatus.*—The apparatus for measuring the twist consisted merely of a pair of mirrors mounted on the grips 2 and 3, a scale placed horizontally being read by light reflected at each of the mirrors. Two arrangements occurred to me: one in which the mirrors had their normals perpendicular to the axis of the specimen (see fig. 12), and one in which they were inclined at 45° or so (see figs. 10 & 11). In these figures the course of the ray of light is indicated roughly by the broken line, the scale

being shown at the right-hand side, and the telescope or source of light being upon the left. The amount of twist of the specimen is determined by observing the change of reading of the scale by means of a telescope, the scale being observed by reflexion at both of the mirrors.

The second was the method selected, it being easily applicable to specimens of varying lengths.

The mirrors are mounted upon frames resting upon the spheres c_1, c_2, d ; e_1, e_2, f of the grips, which are left vacant by the withdrawal of the adjuster. The two frames are exactly similar. The angle c_1, c_2, d is a right angle; the contact of the frame with c_1, b is made by means of a trihedral hole mounted on a screw, with c_2 by means of a fixed V-groove, and with d by means of a plane at the end of a screw. The normals to the mirrors can be adjusted within certain limits by the use of these screws. The various surfaces are kept in contact by the use of the springs shown in fig. 4.

Had the other method been adopted, one or both mirrors would have had to have been mounted upon sliding bars so that they could have been adjusted opposite to one another, when the grips (for torsion purposes) were placed at various distances apart. No special adjustment, however, would have been required to secure accuracy.

If, in the inclined mirror case, we consider the lower grip stationary and the top mirror alone to twist, it is very evident that the twist of the upper mirror is the same as the angle through which the reflexion of the optical axis of the reading-telescope is turned, and is therefore, to the second order of small quantities, equal to the change of scale-reading divided by the distance from the telescope to the scale. The lower grip, however, must be allowed to twist in order that the stress in the specimen between the grips may be of the normal type, uninfluenced by the proximity of the holders; in the following investigation it will be shown that, when a certain adjustment is made, the scale-reading divided by the distance from the specimen to the scale is equal to the twist of the specimen between the grips, at any rate as closely as the tangent of the angle is equal to the angle.

36. *Proof that the Torsion-Mirrors measure the Twist.*—The light from the scale first strikes the upper mirror, and is thence reflected on to the lower mirror, whereby it is reflected to the telescope. In order, however, to ascertain the effect of a simultaneous twist of the two grips, we shall take the line in the reverse direction, and consider the optical axis of the telescope and the direction of its

reflexions at each of the mirrors. The distance between the mirrors will be neglected, as it should be small compared with the distance from the specimen to the scale, or else a lens should be placed between the top mirror and the scale to render the light proceeding from the latter parallel. In the apparatus as rigged for the tests, the distance between the mirrors was 2 or 3 inches, and the distance to the scale over 200, so that this condition was satisfied.

In fig. 13, OC is the axis of the specimen, OA is perpendicular to OC and in the plane of the optical axis of the telescope, OB is perpendicular to OA and OC. The line OK, coordinates $\frac{\pi}{2} - \alpha_1, 0$ or $x_1, 0, z_1$, is the optical axis of the telescope, and cuts a sphere of unit radius whose centre is O in the point K. The normal to the mirror nearest the telescope is represented by OP, coordinates $\frac{\pi}{4} + \theta_1, \phi_1$; or ξ_1, η_1, ζ_1 . The reflexion of OK in the mirror is OL, coordinates α_2, β_2 , or x_2, y_2, z_2 , so that OL represents the path of the ray between the mirrors. The normal to the upper mirror is represented by OQ, coordinates $\frac{\pi}{4} + \theta_2, \phi_2$, or ξ_2, η_2, ζ_2 ; this line is shown drawn in the same octant as the other lines for the sake of clearness, though it should actually be reversed; but a little consideration will show that, by considering the light to come in the direction LO, it will, after reflexion in the second mirror, proceed in the direction OM, coordinates θ, ϕ or x, y, z ; while the actual ray of light will merely be in the direction KO, instead of OK. The quantities α ; the error of setting the telescope in altitude; θ_1, θ_2 the errors of setting the mirrors; and ϕ_1 and ϕ_2 , the azimuthal movements of the mirrors, are supposed small, ϕ_2 being considerably larger than any of the others.

Then $x_1 = 1$ nearly, z_1 is small;
 $z_2 = 1$ nearly, x_2 and y_2 are small;
 $x = 1$ nearly, y and z are small.

We have to find θ and ϕ or x, y, z .

Also the coordinates of

K are $x_1 y_1 z$ or $1 - \frac{\alpha_1^2}{2}; 0; \alpha_1$.

P are $\xi_1 \eta_1 \zeta_1$,

or $\sin \frac{\pi}{4} + \theta_1 \cos \phi_1; \sin \frac{\pi}{4} + \theta_1 \sin \phi_1; \cos \frac{\pi}{4} + \theta_1;$

or

$$\frac{1}{\sqrt{2}} \left\{ 1 + \theta_1 - \frac{\theta_1^2}{2} - \frac{\phi_1^2}{2} \right\}; \quad \frac{1}{\sqrt{2}} (1 + \theta_1) \phi_1; \quad \frac{1}{\sqrt{2}} \left\{ 1 - \theta_1 - \frac{\theta_1^2}{2} \right\}.$$

Q are $\xi_2 \eta_2 \zeta_2$,

or $\sin \frac{\pi}{4} + \theta_2 \cos \phi_2; \quad \sin \frac{\pi}{4} + \theta_2 \sin \phi_2; \quad \cos \frac{\pi}{4} + \theta_2;$

or

$$\frac{1}{\sqrt{2}} \left\{ 1 + \theta_2 - \frac{\theta_2^2}{2} - \frac{\phi_2^2}{2} \right\}; \quad \frac{1}{\sqrt{2}} \left(1 + \theta_2 - \frac{\theta_2^2}{2} \right) \phi_2; \quad \frac{1}{\sqrt{2}} \left(1 - \theta_2 - \frac{\theta_2^2}{2} \right).$$

To find L or $x_2 y_2 z_2$, we have :—

(1) Since $\angle \text{LOP} = \angle \text{KOP}$,

$$x_2 \xi_1 + y_2 \eta_1 + z_2 \zeta_1 = \xi_1 x_1 + \eta_1 y_1 + \zeta_1 z_1. \quad \dots \quad (1)$$

And (2), since LOPK is a plane,

$$\begin{vmatrix} x_2 & y_2 & z_2 \\ \xi_1 & \eta_1 & \zeta_1 \\ x_1 & y_1 & z_1 \end{vmatrix} = 0 \quad \dots \quad (2)$$

and

$$x_2^2 + y_2^2 + z_2^2 = 1. \quad \dots \quad (3)$$

Hence from (1)

$$\begin{aligned} &x_2 \left(1 + \theta_1 - \frac{\theta_1^2}{2} - \frac{\phi_1^2}{2} \right) + y_2 (1 + \theta_1) \phi_1 + z_2 \left(1 - \theta_1 - \frac{\theta_1^2}{2} \right) \\ &= \left(1 + \theta_1 - \frac{\theta_1^2}{2} - \frac{\phi_1^2}{2} \right) \left(1 - \frac{\alpha_1^2}{2} \right) + \left(1 - \theta_1 + \frac{\theta_1^2}{2} \right) \alpha_1, \quad \dots \quad (4) \end{aligned}$$

or to the first order

$$x_2 (1 + \theta_1) + y_2 \phi_1 + z_2 (1 - \theta_1) = 1 + \theta_1 + \alpha; \quad \dots \quad (4a)$$

$$\therefore x_2 + z_2 = 1 \text{ to first order.} \quad \dots \quad (5)$$

From (2)

$$\begin{vmatrix} x_2 & y_2 & z_2 \\ 1 + \theta_1 - \frac{\theta_1^2}{2} - \frac{\phi_1^2}{2}, & (1 + \theta_1) \phi_1, & 1 - \theta_1 - \frac{\theta_1^2}{2} \\ 1 - \frac{\alpha_1^2}{2} & 0 & \alpha_1 \end{vmatrix} = 0;$$

or

$$x_2\phi_1\alpha_1 + y_2\left(1 - \alpha_1 - \theta_1 - \alpha_1\theta_1 - \frac{\theta_1^2}{2} - \frac{\alpha_1^2}{2}\right) - z_2(1 + \theta_1)\phi_1 = 0; \quad (6)$$

or to the first order,

$$y_2(1 - \theta_1 - \alpha_1) - z_2\phi_1 = 0; \quad \dots \dots \quad (6a)$$

hence y_2 is a small quantity.

Substituting in (3),

$$x_2^2 + z_2^2 = 1,$$

which combined with (5) gives us as values $x_2 = 0$ and $z_2 = 1$.
(The values $x_2 = 1$ and $z_2 = 0$ correspond to K.)

Also it is evident that $1 - z_2 = \lambda$ is of the second order.

[For

$$\begin{aligned} x_2^2 + y_2^2 + z_2^2 &= x_2^2 + y_2^2 + (1 - \lambda)^2 \\ &= 1 - 2\lambda + (x_2^2 + y_2^2 + \lambda^2); \end{aligned}$$

$\therefore \lambda$ is of second order.]

\therefore (4a) becomes $x_2 - \theta_1 = \theta_1 + \alpha_1,$

and (6a) becomes $y_2 - \phi_1 = 0;$

hence $\left. \begin{aligned} x_2 &= 2\theta_1 + \alpha_1, \\ y_2 &= \phi_1, \\ z_2 &= 1, \end{aligned} \right\} \text{to first order.}$

Let the terms of the second order in x_2, y_2, z_2 be λ, μ, ν respectively; then from (4)

$$\begin{aligned} &(2\theta_1 + \alpha_1 + \lambda)(1 + \theta_1) + \phi_1^2 + (1 + \nu)\left(1 - \theta_1 - \frac{\theta_1^2}{2}\right) \\ &= \left(1 + \theta_1 - \frac{\theta_1^2}{2} - \frac{\phi_1^2}{2}\right)\left(1 - \frac{\alpha_1^2}{2}\right) + \left(1 - \theta_1 - \frac{\theta_1^2}{2}\right)\alpha_1. \end{aligned}$$

Hence

$$\lambda + \nu = -2\theta_1^2 - 2\alpha_1\theta_1 - \frac{\alpha_1^2}{2} - \frac{3}{2}\phi_1^2. \quad \dots \quad (7)$$

Substituting in (3),

$$4\theta_1^2 + 4\theta_1\alpha_1 + \alpha_1^2 + \phi_1^2 + 1 + 2\nu = 1;$$

$$\therefore \nu = -\left(2\theta_1^2 + 2\theta_1\alpha_1 + \frac{\alpha_1^2}{2} + \frac{\phi_1^2}{2}\right);$$

$$\therefore \lambda = -\phi_1^2;$$

and substituting in (2),

$$\begin{vmatrix} 2\theta_1 + \alpha_1 + \lambda, & \phi_1 + \mu, & 1 + \nu \\ 1 + \theta_1 - \frac{\theta_1^2}{2} - \frac{\phi_1^2}{2}, & \phi_1 + \theta_1\phi_1, & 1 - \theta_1 - \frac{\theta_1^2}{2} \\ 1 - \frac{\alpha_1^2}{2}, & 0, & \alpha_1 \end{vmatrix} = 0.$$

From which we get

$$\mu = \phi_1(2\theta_1 + \alpha_1).$$

So that to the second order of small quantities,

$$\left. \begin{aligned} x_2 &= 2\theta_1 + \alpha - \phi_1^2, \\ y_2 &= \phi_1 + \phi_1(2\theta_1 + \alpha_1), \\ z_2 &= 1 - 2\theta_1^2 - 2\theta_1\alpha_1 - \frac{\alpha_1^2}{2} - \frac{\phi_1^2}{2}. \end{aligned} \right\}$$

We now proceed to find x, y, z from equations similar to (1), (2), and (3), namely,

$$x\xi_2 + y\eta_2 + z\zeta_2 = x_2\xi_2 + y_2\eta_2 + z_2\zeta_2, \quad \dots \dots (8)$$

$$\begin{vmatrix} x & y & z \\ \xi_2 & \eta_2 & \zeta_2 \\ x_2 & y_2 & z_2 \end{vmatrix} = 0, \quad \dots \dots (9)$$

and $x^2 + y^2 + z^2 = 1.$

Equation (8) becomes

$$\begin{aligned} x\left(1 + \theta_2 - \frac{\theta_2^2}{2} - \frac{\phi_2^2}{2}\right) + y(1 + \theta_2)\phi_2 + z\left(1 - \theta_2 - \frac{\theta_2^2}{2}\right) \\ = (2\theta_1 + \alpha_1 - \phi_1^2)(1 + \theta_2) + \{\phi_1 + \phi_1\overline{2\theta_1 + \alpha_1}\}(1 + \theta_2)\phi_2 \\ + \left(1 - 2\theta_1^2 - 2\theta_1\alpha_1 - \frac{\alpha_1^2}{2} - \frac{\phi_1^2}{2}\right)\left(1 - \theta_2 - \frac{\theta_2^2}{2}\right); \quad (10) \end{aligned}$$

or to the first order,

$$\begin{aligned} x(1 + \theta_2) + y\phi_2 + z(1 - \theta_2) &= 2\theta_1 + \alpha_1 + 1 - \theta_2. \quad (10a) \\ \therefore x + z &= 1. \end{aligned}$$

Equation (9) becomes

$$\begin{vmatrix} x & y & z \\ 1 + \theta_2 - \frac{\theta_2^2}{2} - \frac{\phi_2^2}{2}, & \phi_2(1 + \theta_2), & 1 - \theta_2 - \frac{\theta_2^2}{2} \\ 2\theta_1 + \alpha_1, & \phi_1 & 1 \end{vmatrix} = 0;$$

hence

$$x\{\phi_2(1+\theta_2)-\phi_1(1-\theta_2)\} + y\left\{\overline{2\theta_1+\alpha_1}(1-\theta_2)-\left(1+\theta_2-\frac{\theta_2^2}{2}-\frac{\phi_2^2}{2}\right)\right\} + z\{\phi_1(1+\theta_2)-\phi_2(2\theta_1+\alpha_1)\} = 0; \dots \dots \dots (11)$$

or to the first order,

$$x(\phi_2-\phi_1) + y(2\theta_1+\alpha-1-\theta_2) + z \cdot \phi_1 = 0; \dots \dots (11 a)$$

therefore y is small,

and $x^2 + z^2 = 1$ to the second order,

and $x + z = 1$ to the first order.

$$\therefore x=1 \text{ and } z=0.$$

[The solutions $x=0, z=1$ refer to the point L.]

\therefore as before, $x=1$ to the second order.

From (10 a) $1 + \theta_2 + z = 2\theta_1 + \alpha_1 - \theta_2,$

$$\therefore z = 2\theta_1 - 2\theta_2 + \alpha;$$

and from (11 a) $\phi_2 - \phi_1 - y = 0,$

$$\therefore y = \phi_2 - \phi_1.$$

Hence $x = 1 + \rho,$

$$y = \phi_2 - \phi_1 + \sigma,$$

$$z = 2(\theta_1 - \theta_2) + \alpha + T,$$

where $\rho, \sigma,$ and T are quantities of the second order.

To find σ consider equation (11), it becomes

$1 + \rho,$	$\phi_2 - \phi_1 + \sigma,$	$2\theta_1 - 2\theta_2 + \alpha + T$	$= 0.$
$1 + \theta_2 - \frac{\theta_2^2}{2} - \frac{\phi_2^2}{2},$	$\phi_2 + \theta_2\phi_2,$	$1 - \theta_2 - \frac{\theta_2^2}{2}$	
$2\theta_1 + \alpha_1 + \phi_1^2,$	$\phi_1 + \overline{2\theta_2 + \alpha} \cdot \phi_1,$	$1 - 2\theta_1^2 - 2\theta_1\alpha_1 - \frac{\alpha_1^2}{2} - \frac{\phi_1^2}{2}$	

The terms of the second order are

$$\theta_2\phi_2 - \overline{2\theta_1 + \alpha}\phi_1 + \theta_2\phi_1 + \overline{\phi_2 - \phi_1}(2\theta_1 + \alpha_1 - \theta_2) - \sigma + (2\theta_1 - 2\theta_2 + \alpha)\phi_1 = 0;$$

$$\therefore \sigma = (\phi_2 - \phi_1)(2\theta_1 + \alpha).$$

Hence we see that the scale-reading is $(\phi_2 - \phi_1)(1 + 2\theta_1 + \alpha),$ and that the horizontal cross-hair of the eyepiece will move across the image of the scale through an angle δz or $\delta(\overline{2\theta_1 - \theta_2 + \alpha}).$ This remains constant, so that the movement across the scale due to twist of the specimen is very small,

Now in the use of this instrument ϕ_2 is of a larger order than any of the other quantities, but if the other quantities ϕ_1 , θ_1 , θ_2 , and α are all zero, it is evident that ϕ and ϕ_2 are exactly equal.

$$\text{Hence} \quad \phi = (\phi_2 - \phi_1)(1 + 2\theta_1 + \alpha)$$

to quantities of the orders

$$\phi_2^3, \phi_1^2, \theta_1^2, \theta_2^2, \alpha_1^2.$$

$$\text{Now put} \quad \phi_2 = \phi_1 = 0.$$

Then the ray lies in the plane COA, and

$$\begin{aligned} \text{COZ} &= \text{COP} - \text{LOP} = \text{COP} - \text{KOP} \\ &= \text{COP} - (\text{AOP} - \text{AOK}) \\ &= \frac{\pi}{4} + \theta_1 - \left(\frac{\pi}{4} - \theta_1\right) + \alpha_1 \\ &= 2\theta_1 + \alpha_1. \end{aligned}$$

Hence if we make the reflexion of the optical axis in the first mirror parallel to the axis of the telescope, the value of ϕ becomes $\phi_2 - \phi_1$, or the scale-reading divided by the distance to the scale is the twist between the mirrors to the orders of small quantities stated above. This adjustment is made by the use of the adjusting-screws of the lower mirror, the telescope being sighted so as to have the lower mirror at the centre of its field, and then the mirror adjusted so that a point similarly situated with respect to the specimen as the centre of the lower mirror appears at the centre of the field.

The adjustment was tested by turning the specimen as a whole through an angle of 0.1, when it was found that the scale-reading changed through an angle corresponding usually to about 0.001.

The greatest value of ϕ_2 was about 0.05, the cube of which is 0.000125; the corresponding value of ϕ_1 would be about one-eighth of ϕ_2 or 0.006, and ϕ_2^2 would be 0.00004. The error of ϕ would hence be about 0.25 per cent., which is quite negligible.

It will be noticed that azimuthal errors in the settings of the mirrors are of no effect, being parts of ϕ_2 and ϕ_1 , changes of which alone affect the value of ϕ .

37. *The Effect of Bending.*—Unfortunately, the effect of bending* was not investigated until the series of tests had

* For the suggestion that I should investigate the effect of bending, I am indebted to Mr. E. G. Coker, Assist. Prof. of Civil Engineering, McGill University.

been practically completed; otherwise the alternative arrangement of the twist-mirrors, which is free from such defects, would probably have been preferred although not readily applicable to specimens of different lengths.

Bending in a plane through the telescope and specimen has the effect of causing the image of the scale to move vertically across the field of the telescope, but it does not affect the reading.

Bending in a plane at right angles to this, however, has an effect upon the reading. If the angle $CAP = \psi$ and $POA = \chi$, we have

$$\cos \theta = \sin \chi \cos \psi,$$

$$\tan \phi = \tan \chi \sin \psi,$$

and bending alters the value of ψ , so that the effect of bending is to produce

$$\delta \theta = \frac{\sin \chi \sin \psi}{\sin \theta} \delta \psi = 0 \text{ nearly.}$$

$$\delta \phi = \frac{\tan \chi \cos \psi}{\sec^2 \phi} \delta \psi = \delta \psi \text{ nearly.}$$

So that the bending is added to the twist.

In the tests, however, a small load (250 lbs.) having been placed on the specimen, the bearings were tapped until the alignment had taken place. In pure torsion tests then the bending could have had no effect; and in the combined tests, as the torsion load was applied first and then the axial load, if the latter produced any bending it would alter the reading of the twist. On only one occasion was this of any magnitude, and usually the reading remained nearly constant until the yield-point was reached, when it increased. I therefore do not think that the source of error indicated above had an appreciable effect on the twist readings.

38. *As a Transmission Dynamometer.*—It may be noticed that in the case where the normals to the mirrors are perpendicular to the specimen, the reflected optical axis is turned through twice the angle the specimen twists through, and this relationship is exact. By using a ray of light of small cross section and allowing it, after reflexion at the two mirrors, to fall upon a scale, its position will indicate the twist between the mirrors; and since the reading can be taken when the light is intermittent, the device forms a cheap and convenient form of transmission dynamometer.

39. *The Diametral Extensometer.*—The diametral extensometer (fig. 14, p. 93) consists of a piece l resting in contact with the specimen at the surfaces $A B C D$ forming parallel V 's

(as in the Adjuster) ; to this was hinged by an axis resting in two V's E, F, and a point at the end of the axis resting on a surface G, a lever 2. The lever 2 has a projection H which was kept in contact with the tube by a spring K. The piece 1 also carried the V-bearings L, M of a mirror-frame 3, the axis of the bearings being perpendicular to the axis of the specimen. The mirror-frame was connected to a screw working in the lever 2 by means of a link 4 ; the link having sharp knife-edges of V-form which worked on knife-edges on the screw and mirror-frame. The instrument was supported partly by springs, and partly by the friction at the surface of the tube. The distance of the knife-edge N fastened to the mirror-frame, and upon which the link 4 worked, being small, its distance from the axis of rotation of the mirror-frame was determined by clamping the piece 1 and a micrometer-screw in such a way that turning the screw pushed, by means of a small distance-piece, the knife-edge through a definite amount. The twist of the mirror was then determined optically. The amount of the strain corresponding to any twist of the mirror can then be easily calculated ; it being remembered that, owing to the use of V's for the tube to rest in, the movement of H relative to the piece 1 is not simply the increase of the diameter, but is to be considered as the effect of an enlargement of the tube. If α is the semi-angle of the V's, the distance from the point of the V to the point of contact of the lever is $r(1 + \operatorname{cosec} \alpha)$, where r is the radius of the tube. Hence an increase of radius δr corresponds to a movement of the lever at the point of contact with the tube of $\delta r(1 + \operatorname{cosec} \alpha)$.

40. *Method of making the Tests.*—In making the tests, a tube, after its dimensions had been determined, was soldered on to the holders and then placed in the testing-machine, and a load of 250 lbs. applied, and the shackle-bearings tapped in order to make the specimen line itself up as accurately as possible. This load of 250 lbs. was employed as it pulled into contact the surface of the lower head of the testing-machine, which would not be in contact permanently until the load on the specimen exceeded the weight of all the parts between it and the straining-gear of the machine. [There was also a slight amount of backlash in the nut of the screw.] The torsion-bars and steel points were placed in their positions, and the screws in the bracket adjusted to just touch the lower cross-bar. The grips of the extensometer were then fixed to the specimen by the use of the adjuster, and the lower torsion-mirror applied. The telescope for the torsion-tests was then adjusted opposite the lower mirror with its optical axis horizontal, and the lower mirror was adjusted by the screws in

its frame until the reflexion of the optical axis was parallel to the specimen. The top mirror was then fixed to the top grip and the torsion-scale placed at the same level: the screws of the top mirror were then adjusted until the image of the scale appeared horizontal and at the centre of the field. The scale was then moved horizontally until the reading was nearly zero, the final adjustment to zero being made just before a test by the azimuth-screw of the telescope. The adjustment of the mirrors is such as to satisfy the condition found above (§ 36) for the vanishing of the terms of the second order in the expansion of the twist. The remaining parts of the extensometer were then placed in position, and the scale for axial extensions being moved so that its centre was opposite the mirror, the second screw Q was used to adjust the reading to nearly zero, the final adjustment being made by the altitude-screw of the corresponding telescope. The diametral extensometer was then adjusted on the specimen, above the other and strain apparatus.

The various forces were applied by suitable increments, and readings of the extensometer taken at each application: the time-effect at the elastic limit was looked for, and at its appearance the forces were applied by smaller amounts until it was judged that the yield-point had been reached. In tests involving tension and torsion the torque was applied first; during the application of the tension-load the first reading seldom changed appreciably, though it usually changed a few divisions. On only one occasion was the change (indicating a bending-moment) considerable. In all tests involving internal pressure, the pressure was applied last, as it was somewhat difficult to keep it constant at a desired amount. In the Tables the tension-loads are denominated by the letter P, and expressed in pounds-weight; the loads producing torque by W, so that the torques are $15 W$ inch-lbs., the cross-bar being 30 inches long between the points; the fluid pressure as recorded by the gauge by p_0 , the corresponding pressure being obtained from the table of gauge corrections. The reading of the axial extensometer is called the axial reading, the factor to reduce this is changed in the course of the tests; otherwise all scales were placed at standard distances. This factor was 0.000001286 for tubes I., II., III., X., XI., XII., XIII., and 0.000001265 for the remainder. The reading to determine the twist is called the twist-reading; the factor to reduce it to shearing-strain or slide varies with the diameter of the tube, for a $1\frac{1}{4}$ -inch diameter tube it is 0.00000377. The diametral extensometer readings have not been tabulated, it having been deemed more reliable to deduce the strain from the elastic constants; the factor to reduce scale-readings to

strains was 0.00002022 for a $1\frac{1}{4}$ -inch diameter tube. Examples of the results of this extensometer will be found plotted in some of the stress-strain curves (figs. 21, 23, & 24).

The values of P , W , p_0 , the axial and the twist readings for the yield-point in the various tests are tabulated in Tables VI., VII., and VIII. under the head of observations.

41. *Determination of the Sectional Area and Thickness of the Tubes.*—The external diameter of the specimens was determined by the use of a micrometer-caliper; they were all practically uniform. The thickness was determined in every case by calipering, and also indirectly from the area of cross-section. The cross-section was determined in cases I., III., X., XI., XII., and XIII. by weighing the tubes in air and in water, the tubes being well boiled in the water, and the specific gravity of the water at the temperature checked. The density as well as the cross-section was thus determined. The other tubes were weighed and the thickness deduced from the result: as it always closely agreed with the makers' statement and with the result of direct measurement, the values may be regarded as fairly close. It should be noticed that errors in the thickness will only very slightly affect the relative results of the tests upon a tube, as the change in the mean diameter is the only way by which the relative results would be affected.

42. *Calculation of the Stresses.*—The effect of an axial force P is to produce a stress p , equal to the force divided by the area of the specimen: the values of these stresses for the various experiments are tabulated in the column headed p .

Owing to the smallness of the friction at the bearings, it has not been thought necessary to allow for it in the value of W ; the cases which it affects most are those in which P is large and W comparatively small, the friction being practically proportional to P . The effect of a torque $15W$ is to produce a shearing-stress q in the material of the tube varying from the inner surface to the outer proportionally to the distance from the axis. As the thickness of the tube is only from 0.04 to 0.06 of the radius, the variation of the shearing-stress from its mean value is only 2 or 3 per cent. The value of q is taken as equal to the torque divided by the product of the area of section and the mean radius. A simple shearing-stress q is equivalent to two principal stresses $+q$ and $-q$. It is to be noticed that neither tension, torsion, nor their combination produces a third principal stress.

The effect of the fluid pressure is to produce an axial stress p_1 and a circumferential stress whose mean value is $2p_1$,

where $p_1 = \frac{\pi(r-t)^2}{\text{area}} \times \text{fluid pressure}$; and a radial stress varying from the value of the fluid pressure at the interior surface to zero at the exterior surface.

Since in a cylinder under internal pressure the circumferential stress is given by the equation $p = C \left(1 + \frac{r_0^2}{r^2} \right)$, where r_0 is the external radius and r the radius at which the stress is p , the circumferential stress at the interior bears to that at the exterior the ratio $\frac{1}{2} \left(1 + \frac{r_0^2}{(r_0-t)^2} \right) = 1 + \frac{t}{r}$ nearly. Hence the variation from the mean value is about 2 or 3 per cent., as in the case of the shearing-stress due to torque.

In the calculations the mean values of the radius have been used, and no notice taken of the variation of the stress. In the hydraulic tests the actual amount of variation in pounds per sq. inch is equal to the value of the fluid pressure, since the sum of the radial and circumferential stresses is the same throughout the material of the cylinder.

The value of the axial stress due to the fluid pressure at the yield-point in the test is tabulated in the column headed p_1 . In the case of a simultaneous tension-load producing an additional stress p_0 , this is simply added on, so that the principal stresses are then $p + p_1$ axially, $2p_1$ circumferentially, and $\frac{1}{2}p_0$ radially.

To find the principal stresses when torsion is combined with tension or internal pressure, notice first that the radial stress is always perpendicular to the other components and to the plane of the shear, and hence it is a principal stress, and the case reduces to one of two dimensions and the stress ellipsoid to

$$p_1x^2 + 2qxy + p_2y^2 = 1,$$

where p_1, p_2 are the component axial and circumferential stresses and q the shearing-stress. The principal stresses ω_1, ω_2 are then the roots of the discriminant

$$\begin{vmatrix} p_1 - \omega & q \\ q & p_2 - \omega \end{vmatrix} = 0;$$

and hence are the values of

$$\omega = \frac{p_1 + p_2 \pm \sqrt{p_1 - p_2^2 + 4q^2}}{2}.$$

From this equation are obtained the tabulated values of ω_1 and ω_2 . The angle at which the principal stresses are inclined to the generators may be found from its algebraic value

$$\tan^{-1} \frac{2q}{p_2 - p_1}.$$

In the tables of results the next column contains the maximum shearing-stress; this takes place in a plane perpendicular to the axis of mean principal stress, and is that of the plane through the mean axis bisecting the angles between the other principal stresses: its value is half the difference between the greatest and least principal stresses. It will be noticed in the case of those experiments in which the stresses in the tangential plane are of opposite signs, that this tangential plane is the plane of the greatest shear, but that in the other cases the plane passes through the axis of the tube. The value of the maximum shearing-stress in cases involving torsion is, from the value of the principal stresses,

$$\sqrt{\left(\frac{p_1 - p_2}{2}\right)^2 + q^2}.$$

43. *Calculation of the Strains.*—Owing to the elastic-limit effect the measured strains vary more than the stresses, especially as the elastic-limit effect is practically absent in a test when the immediately preceding test is of the same type.

In the simple torsion tests the value of the shearing-strain or slide ϕ is obtained directly from the reading by the use of the factor. If i be the angle of twist of the specimen in a length l , r the radius of the specimen, d the distance to the scale, measured in the same units as x the scale-reading, we have

$$\phi = \frac{r}{l} i = \frac{r}{l} \frac{x}{d}.$$

The principal component strains which produce the slide ϕ are $\eta_1 = \frac{1}{2}\phi$; $\eta_2 = -\frac{1}{2}\phi$; and $\eta_3 = 0$.

The effect of an axial stress is not only to produce an axial strain, but to produce a uniform strain of the opposite sign in all directions at right angles to it, and bearing to it, in amount, the value of Poisson's ratio (σ). The value of the axial strain was determined from the corresponding scale-reading by the use of a factor; the value of the resulting contractile strain was obtained by multiplying this by the value of σ deduced from the values of E and C for the specimen, in preference to using the results of the diametral extensometer.

In the combined tension and torsion tests, the value of the principal strains was obtained from the observed value of the axial strain ϵ_1 and of the slide ϕ , and by taking the value of the circumferential strain as $-\sigma\epsilon_1$. Since ϕ is the only slide the strain ellipsoid becomes

$$\epsilon_1 x^2 + \epsilon_2 y^2 + \epsilon_3 z^2 + \phi xy = 1,$$

where ϵ_2 and ϵ_3 are the strains perpendicular to ϵ_1 . The

discriminant then becomes

$$\begin{vmatrix} \epsilon_1 - \eta & \frac{1}{2}\phi \\ \frac{1}{2}\phi & \epsilon_2 - \eta \end{vmatrix} = 0;$$

and the principal strains have the values

$$\frac{1}{2}\{\epsilon_1 + \epsilon_2 \pm \sqrt{(\epsilon_1 - \epsilon_2)^2 + \phi^2}\}; \epsilon_3.$$

The maximum shear-strain, being the difference between the greatest and least principal stresses, is

$$\sqrt{(\epsilon_1 - \epsilon_2)^2 + \phi^2}.$$

In the case of the internal pressure experiments, the strains have been calculated from the values of the principal stresses and of the elastic constants. The results so obtained are always less than the measured values of the strains would be; as in the tension and internal pressure the axial strain is a principal one, its measured volume in the column "Axial strain" can be compared with its calculated value in the column η_1 of the principal strains.

The maximum slides or shear-strains, being in value equal to the difference between the greatest and least principal strains, have also been tabulated; these should be, but for the elastic-limit effect, directly proportional to the maximum shearing-stresses, and independent of the third stress.

44. *Maximum Shear and Slide are proportional.*—For if the principal stresses be $\varpi_1, \varpi_2, \varpi_3$, then the maximum shearing-stress perpendicular to ϖ_3 is $\frac{1}{2}(\varpi_1 - \varpi_2)$. The principal strains are $\frac{1}{E}(\varpi_1 - \sigma\varpi_2 - \sigma\varpi_3), \frac{1}{E}(\varpi_2 - \sigma\varpi_3 - \sigma\varpi_1), \frac{1}{E}(\varpi_3 - \sigma\varpi_1 - \sigma\varpi_2)$,

and the corresponding maximum slide to $\frac{1}{2}(\varpi_1 - \varpi_2)$ is $\frac{1 + \sigma}{E}$

$\times (\varpi_1 - \varpi_2)$. So that the maximum slide directly corresponds to the maximum shearing-stress and is independent of the stress normal to its plane. Thus the comparison of the maximum shear and slide columns in the tables of results will indicate the magnitude of the elastic-limit effect.

45. *Quantities tabulated.*—Thus for the tests the values of the principal stresses, of the principal strains, of the maximum shear, and the maximum slide at the yield-point have been tabulated; a column has also been included giving the maximum principal strain as calculated from the elastic constants and stresses, this being the yield-point strain on the supposition that Hooke's law holds up to the yield-point.

The values of E , Young's modulus, and C , the modulus of rigidity, have been calculated from the elastic ratio of stress and strain in the tension and torsion experiments; they have

slight variations for the same tube. The value of σ , Poisson's ratio, has been deduced from these by the formula $\sigma = \frac{E}{2C - E}$, which is a method evidently liable to large errors; these, however, I do not think are serious enough to affect the conclusions I have drawn from the tables of results, as the chief conclusions are deduced from the stresses. I had intended to deduce the value of σ directly from the internal pressure tests; the axial elongation due to a pressure p_0 , producing stresses p_1 and $2p_1$, being $\frac{p_1}{E}(1 - 2\sigma)$, so that $\sigma = 0.5 - \frac{E}{2p_1} \times (\text{axial strain})$. The method of attaching the tube conveying the oil to the specimen was not perfect, and seemed to tilt the tube slightly as a whole, so that this method was not used. Perhaps Regnault's method would have been most appropriate.

The results of the experiments are given in Tables V. (Solid Bars), VI. (Steel Tubes), VII. (Copper Tubes), and VIII. (Brass Tubes), where the observations made at the yield-point and the results will be found.

46. *Results of the Experiments.*—For the more ready presentation of the results of the experiments, diagrams of various types have been drawn, and will be described as referred to.

The Tests on Solid Bars.—In the case of the solid-bar tests it will be observed that the yield-point stresses (see Table V.) rise as the course of tests proceeds: this indicates that the yield-point of the outer layers must have been much exceeded (§ 5). A glance at the torque-twist diagram (fig. 15) for the torsion-tests will clearly demonstrate the difficulty of locating the yield-point; though the tables merely embody my estimations of its occurrence, the curves at any rate represent actual occurrences, and permit of the ready comparison of points considered to correspond. The results may be held, with previous torsion experiments, to disprove the maximum-stress theory, as the ratios of the maximum stresses in the torque and tension tests are 0.615 to 0.69 for the iron, and 0.565 for the steel. They are also at variance with the maximum-strain theory, the values of the ratio for the experimental values of σ being 0.75 and 0.71 respectively. In this and some of the succeeding figures the time-effect is shown by observations giving different strains under a constant stress; the first observations were taken immediately the loads were applied; in some cases the intervals of time are given.

SYNOPSIS OF TUBE-TESTS.

NOTATION.

The tests on any tube are numbered in order of performance.

All results refer to the yield-point.

P = actual tension-load on specimen.

W = load producing the torque 15 W.

p_0 = corrected value of internal pressure.

Axial-strain = actual reading of the axial extensometer-scale.

Twist-strain = , , , twist-scale.

p = the tensile-stress due directly to P.

q = the shearing-stress due directly to W.

p_1 = the axial stress due directly to p_0 .

$\omega_1, \omega_2, \omega_3$ = the principal stresses.

Axial strain as measured = the value of the strain as deduced from the reading of the axial scale.

Twist-strain as measured = the value of the slide as deduced from the reading of the twist-scale.

η_1, η_2, η_3 are the principal strains.

TABLE IV.
Diameters, Elastic Constants, &c. of Tubes.

No. of Tube.	Material.	Diam.	Thick-ness.	Area.	E.	C.	σ .
I.	Steel	1.316	0.029	0.1175	30,400,000	10,960,000	0.39
II.	"	1.250	0.028	0.1075	29,500,000	11,450,000	0.287
III.	"	0.4987	0.0245	0.0364	28,900,000	10,660,000	0.355
IV.	"	1.25	0.025	0.0971	31,100,000	11,170,000	0.393
V.	"	"	"	"	31,700,000	11,700,000	0.355
VI.	"	"	"	"	30,900,000	11,500,000	0.344
VII.	"	"	"	"	28,800,000	10,850,000	0.328
VIII.	"	"	"	"	31,000,000	11,200,000	0.365
IX.	"	"	"	"	29,600,000	10,400,000	0.423
X.	Copper ...	1.251	0.0362	0.14113	18,100,000	6,280,000	0.43
XI.	" ...	"	"	"	17,200,000	6,000,000	0.43
XII.	Brass	1.255	0.034	0.1295	15,000,000	5,020,000	0.45*
XIII.	"	"	"	"	14,760,000	4,760,000	0.50

The units for the above table are lbs. wt. and inches.

Solid Bars, Elastic Constants, &c.

Material.	Diam.	Area.	E.	C.	σ .
Norwegian Iron ...	0.628	0.3095	29,700,000	11,160,000	0.33
Mild Steel.....	0.504	0.1992	31,800,000	11,270,000	0.40

TABLE V.—Solid Bar Tests.
Elastic Limit.

Material.	Test No.	P.	W.	<i>p</i> .	<i>q</i> .	Max. Shear.	Max. Elongation.
Norwegian Iron .	1	...	30	...	9,000	9,000	0·000403
„	2	5000	...	16,200	...	8,100	0·000554
„	3	5000	20	16,200	6,180	10,200	0·00064
„	4	6700	30	21,700	9,270	14,300	0·00088
„	5	8000	...	26,000	...	13,000	0·00083
„	6	...	48	...	14,800	14,800	0·000665
Mild Steel	1	...	22	...	13,100	13,100	0·000582
„	2	6750	...	33,900	...	16,950	0·001065
„	3						

Yield-point.

Material.	Test No.	P.	W.	<i>p</i> .	<i>q</i> .	Max. Shear.	Max. Elongation.
Norwegian Iron .	1	...	40	...	12,360	12,360	0·00055
„	2	6400+	...	20,700	...	10,350	0·000698
„	3	5000	42½	16,200	13,100	15,300	0·00087
„	4						
„	5	8200	...	26,500	...	13,250	0·000892
„	6	...	59	...	18,200	18,200	0·000815
Mild Steel	1	...	38	...	22,700	22,700	0·001007
„	2	8000	...	40,200	...	20,100	0·001265
„	3	6000	35	30,100	20,900	25,800	0·00142

The above elongations are calculated from the stresses and elastic constants, thus assuming that the linear stress-strain relation holds to the yield-point; the actual strains at the yield-point are greater: *e.g.*, the max. elongation at $W=40$ in Test 1 on the Norwegian iron was at first 0·000587 and increased to 0·000606.

TABLE VI.—Results of Tests. Steel Tubes.

OBSERVATIONS.				CALCULATED STRESSES.						CALCULATED STRAINS.				Maximum Elongation as calculated from Stresses.		
Number of Tube.	Stress.			Applied.			Principal.			Max. Shear.	As measured.			Principal.		Maximum Slide.
	P.	W.	p_0 .	p .	q .	p_1 .	σ_1 .	σ_2 .	σ_3 .		Axial.	Twist.	η_1 .	η_2 .	η_3 .	
I.	1...	5380	88	...	17,900	...	17,900	-17,900	0	17,900	0	0.000832	-0.000832	0	0.001665*	0.000817
	2...	5200	...	45,800	4,500	...	50,300	9,000	0 to -430	25,360	0	0.00155	0.001540
	3...	5260	...	44,300	51,050	13,500	0 to -640	25,840	0	0.00154	0.001500
	4...	5160	...	43,900	...	7,400	51,300	14,800	0 to -700	26,000	0	0.00147	0.001540
	5...	5500	...	46,800	46,800	23,400	0	0.00154	0.001540
	6...	...	88	...	17,900	17,900	-17,900	0	17,900	0	0.000985	-0.000985	0	0.001970
II.	1...	150	135-150	...	30,800 to 34,200	...	30,800 to 34,200	-30,800 to -34,200	0	34,200	0	0.00263 to 0.00304	-0.00131 to 0.00131	;	0.00263 to 0.00304	0.00142
	2...	5500+	...	60,500+	34,200	...	60,500+	...	0	30,250+	0	0.002032	-0.00152	...	0.00304	0.002050
	3...	200	130	...	29,500	...	29,500	-29,500	0	29,500	0	0.00269	-0.00134	...	0.00269	0.001250
	4...	4200	...	39,100	39,100	...	0	18,550	0	0.00132	-0.000379*	...	0.00170	0.001320
	5...	3700	100	some bending	22,800	...	45,800	-11,350	0	28,600	0	0.001182	-0.000848	...	0.00254	0.00168
III.	6...	5950	...	55,500	55,500	0	0	27,750	0	0.002055	-0.000732*	...	0.002732*	0.001880
	7...	6200	...	57,800	57,800	0	0	28,990	0	0.002025	-0.000645*	...	0.002970*	0.001960
	8...	5200	75	48,500	53,900	5,400	0	29,650	0	0.001763	-0.000805	...	0.00291	0.001775
	9...	250	130	...	29,500	...	29,500	-29,500	0	29,500	0	0.00309	-0.00154	...	0.00309	0.001290
	10...	4200	100	885	22,800	...	49,900	-10,500	0	30,350	0	0.002165	-0.000899	...	0.002810	0.001830
	11...	4000	110	...	37,200	...	49,800	-12,400	0	31,200	0	0.001383	-0.00112	...	0.00301	0.001810
	12...	4500	...	1050	41,90	11,000	52,900	22,000	0 to 1050	27,000	0	0.001491	-0.000428	...	0.001919	0.001545
	1...	50	9	...	15,650	...	15,650	-15,650	0	15,650	0	0.001427	-0.000714	...	0.001328	0.000735
	2...	1250	...	34,400	34,400	0	0	17,200	0	0.001217	-0.000432*	...	0.001648*	0.001190
	3...	50	7	...	15,650	...	15,650	-15,650	0	15,650	0	0.001567	-0.000783	...	0.001567	0.000735
	4...	750	9	...	20,600	...	26,250	5,650	0	15,950	0	0.000727	-0.000518	...	0.001505	0.000977
	5...	1000	5	...	27,500	8,650	...	30,050	2,450	16,300	0	0.000342	-0.000808	...	0.001535	0.001070
6...	1200	...	33,000	33,000	0	0	16,500	0	0.001152	-0.000408	...	0.001560	0.001140	
IV.	1...	...	90	...	22,500	...	22,500	-22,500	0	22,500	0	0.002070	-0.001035	...	0.002070	0.001005
	2...	4000	...	41,200	41,200	0	0	20,600	0	0.001385	-0.000545	...	0.001930	0.001325
	3...	2750	70	...	17,500	...	38,650	-8,350	0	22,600	0	0.001030	-0.000640	...	0.002220	0.001350
	4...	3000	...	30,900	37,700	24,000	0 to -1050	22,000	0	0.001152	-0.000530	...	0.001920	0.001078
	5...	...	75	1150	18,750	12,000	42,700	-1,700	0 to -1050	20,200	0	0.001710	-0.000646	...	0.001795	0.001285
	6...	2500	...	1000	25,800	16,900	42,700	33,800	0 to -1500	22,100	0	0.000940	-0.000547	...	0.000975	0.000975
	7...	3400	50	...	35,000	...	39,000	-4,000	0	21,500	0	0.001200	-0.000472	...	0.001980	0.001305
	8...	4000	...	1097	41,200	...	41,200	0	0	20,600	0	0.001388	-0.000545	...	0.001833	0.001325
9...	90	...	561	22,500	...	22,500	-22,500	0	22,500	0	0.00214	-0.000107	...	0.00214	0.001005	

1...	3250	...	949	...	33,500	33,500	0	0	16,750	0*001200	0*001200	-0*000426	0*001626	0*001057
2...	250	...	419	...	17,500	17,500	-17,500	0	17,500	0*000790	0*000790	0	0*001580	0*000748
3...	3600	...	725	...	30,900	30,900	4,100	0	17,500	0*000917	0*001191	-0*000325	0*001790	0*000120
4...	3200	...	889	...	33,000	33,000	0	0	16,500	0*001125	0*001125	-0*000400	0*001425	0*000104
5...	280060	...	754	...	33,000	33,000	-2,300	0	17,700	0*000955	0*000955	-0*000339	0*001555	0*000107
6...	3000	...	780	...	20,600	32,600	24,000	0 to -1050	16,800	0*000987	0*000760	-0*000633	0*001393	0*000760
7...	1500	...	380	...	11,250	12,000	5,500	0 to -1050	15,750	0*000190	0*000900	-0*000403	0*001510	0*000900
8...	1500	...	626	...	15,450	30,350	29,800	0 to -1350	15,900	0*000792	0*000625	-0*000673	0*001298	0*000673
9...	250	...	643	...	2,600	17,500	-17,500	0	17,500	0*001212	0*001212	0	0*002425	0*000748
10...	3300	...	1413	...	34,000	34,000	0	0	17,000	0*001793	0*001793	-0*000637	0*002430	0*001073
1...	3300	...	1440	...	34,000	34,000	0	0	17,000	0*001822	0*001822	-0*000612	0*002434	0*001100
2...	3000	...	971	...	34,000	32,900	24,600	0 to -1100	17,000	0*001230	0*001230	-0*000412	0*001642	0*001100
3...	2000	...	686	...	20,600	30,250	18,900	0 to -850	17,000	0*000867	0*000792	-0*000640	0*001431	0*000792
4...	2500	...	747	...	20,800	16,250	16,250	0 to -850	15,550	0*000945	0*000792	-0*000548	0*001316	0*000768
5...	250	...	524	...	2,600	16,250	16,250	0 to -850	16,250	+	0*000987	-0*000987	0*001975	0*000705
6...	3000	...	985	...	240	33,150	2,250	0	17,700	0*001945	0*001359	-0*000417	0*001890	0*001100
7...	2700	...	778	...	27,800	31,800	4,000	0	17,900	0*000955	0*001255	-0*000539	0*001825	0*000750
8...	551	17,250	-17,250	0	17,250	0*002085	0*001042	0	0*002085	0*000750
9...	2550	...	714	...	26,300	31,250	4,950	0	18,100	0*000904	0*001189	-0*000596	0*001786	0*001065
10...	1500	...	1125P	...	15,450	27,150	23,400	0 to -1050	14,100	0*000904	0*001310	-0*000311	0*001786	0*001065
11...	2000	...	1175	...	20,600	32,900	24,600	0 to -1100	17,000	0*000948	0*000792	-0*000640	0*001432	0*000792
12...	1500	...	590	...	15,450	30,100	29,300	0 to -1300	15,700	0*000746	0*000648	-0*000612	0*001310	0*000648
1...	1500	...	1800	...	15,450	34,350	37,600	0 to -1700	19,750	0*000833	0*000765	-0*000825	0*001744	0*000825
2...	2000	...	1650	...	20,600	38,050	34,900	0 to -1570	19,800	0*000905	0*000926	-0*000751	0*001756	0*000826
3...	2000	...	550	...	20,600	38,800	5,000	0	20,300	0*002070	0*001355	-0*000237	0*002225	0*001130
4...	1400	...	100	...	14,650	38,800	5,200	0 to -1300	20,050	0*001785	0*001501	-0*000480	0*001960	0*001501
5...	3800	...	1216	...	39,200	39,200	28,500	0	19,600	0*001540	0*001540	-0*000505	0*002045	0*001385
6...	607	...	655	...	22,500	22,500	-28,500	0	22,500	0*002385	0*001192	-0*001192	0*002385	0*001385
7...	2800	...	798	...	26,800	35,400	-8,600	0	21,400	0*001010	0*001549	-0*000370	0*002320	0*001825
8...	3400	...	1012	...	35,000	39,000	4,000	0	21,500	0*001280	0*001530	-0*000670	0*002200	0*001400
9...	1500	...	1850	...	15,450	34,950	39,000	0 to -1750	20,400	0*000785	0*000772	-0*000958	0*001800	0*000958
10...	250	...	1900	...	2,600	39,800	39,800	0 to -1800	20,800	0*000205	0*000712	-0*000712	0*001888	0*001128
11...	500	...	162	...	19,900	25,050	39,800	0 to -1800	20,800	0*000263	0*000417	-0*001128	0*001840	0*001100
12...	1000	...	240	...	10,300	30,200	39,800	0 to -1800	20,800	0*000304	0*000596	-0*00104	0*001888	0*001040
13...	2000	...	1900	...	20,600	38,500	35,800	0 to -1600	20,050	0*001155	0*000930	-0*000846	0*001776	0*000930
14...	2500	...	932	...	25,750	43,750	30,000	0 to -1350	20,800	0*001180	0*001075	-0*000388	0*001776	0*000930
15...	1500	...	565	...	15,450	35,350	39,800	0 to -1800	20,800	0*000715	0*001075	-0*000388	0*001776	0*000930
16...	3700	...	1567	...	35,100	38,300	0	0	19,050	0*001990	0*000773	-0*000650	0*001839	0*000982
17...	3600	...	245	...	6,250	38,800	1,700	0	20,250	0*001410	0*001980	-0*000952	0*002630	0*001839
18...	3500	...	1137	...	10,000	38,700	2,570	0	20,600	0*001437	0*001518	-0*000371	0*002690	0*001865
19...	3100	...	1091	...	15,000	37,800	5,900	0	21,900	0*001380	0*001708	-0*000472	0*002440	0*001875
20...	660	...	22,250	29,250	-22,250	0	22,250	0*002315	0*001921	-0*000994	0*002915	0*001880
		0*002485				0*001242	0*001242	-0*001242	0*002485	0*001025

V.

VI.

VII.

TABLE VI. (continued).

Number of		OBSERVATIONS.						CALCULATED STRESSES.						CALCULATED STRAINS.						Maximum Elongation as calculated from Stresses.	
		Stress.			Strain.			Applied.		Principal.		Max. Shear.		As measured.		Principal.			Max. Slide.		
Tube.	Test.	P.	W.	P ₀ .	Axial.	Twist.	p.	q.	p 1.	σ ₁ .	σ ₂ .	σ ₃ .	τ ₃ .	Max. Shear.	Axial.	Twist.	γ ₁ .	γ ₂ .	γ ₃ .	Max. Slide.	
VIII.	1...	...	88.5	585	...	22,100	...	22,100	-22,100	0	0	22,100	...	0.00202	0.00101	-0.00101	0	0.000985	
	2...	...	89	563	...	22,250	...	22,250	-22,250	0	0	22,250	...	0.00212	0.00106	-0.00106	0	0.001005	
	3...	3900	1184	...	40,200	...	40,200	0	0	20,100	...	0.00150	0.00055	-0.00055	0	0.001300	
	4...	3300	899	...	34,000	0	0	21,150	...	0.00135	0.00062	-0.00062	0	0.00413	
	5...	2600	696	...	26,800	0	0	22,000	...	0.00088	0.00076	-0.00076	0	0.00124	
	6...	2500	1004	...	25,750	...	15,750	...	41,500	31,500	0 to -1430	...	21,450	...	0.00169	0.00086	-0.00086	0	0.00109
	7...	2000	738	...	20,600	...	17,900	...	38,500	35,800	0 to -1600	...	20,050	...	0.00082	0.00070	-0.00087	0	0.00082
	8...	1000	474	...	10,300	...	19,650	...	29,950	39,300	0 to -1770	...	20,300	...	0.00060	0.00071	-0.00081	0	0.00087
	9...	500	335	...	5,150	...	19,900	...	25,050	39,800	0 to -1795	...	20,500	...	0.000425	0.00099	-0.00071	0	0.00099
	10...	3000	1124	...	30,900	...	13,500	...	44,400	27,000	0 to -1220	...	22,800	...	0.00142	0.00035	-0.00084	0	0.00112
	11...	1500	588	...	15,450	...	19,600	...	35,050	39,200	0 to -1755	...	20,500	...	0.000743	0.00086	-0.00087	0	0.00087
	12...	500	347	...	5,150	...	20,500	...	25,650	41,000	0 to -1745	...	21,400	...	0.000438	0.00102	-0.00078	0	0.00173
	13...	250	284	...	2,575	...	20,600+	...	31,175	41,200	0 to -2000	...	21,400	...	0.00036	0.00106	-0.00076	0	0.00180
	14...	1000	566	...	10,300	...	21,300	...	21,600	42,600	0 to -1920	...	22,600	...	0.000705	0.00125	-0.00076	0	0.00182
	15...	500	1089	...	25,750	...	16,300	...	42,050	32,600	0 to -1470	...	21,750	...	0.001375	0.00088	-0.00076	0	0.00112
	16...	3500	1251	...	36,100	...	9,450	...	45,500	18,900	0 to -850	...	23,200	...	0.001585	0.00055	-0.00088	0	0.00112
	17...	2000	870	...	20,600	...	19,600	...	40,200	39,200	0 to -1755	...	20,975	...	0.001100	0.00077	-0.00076	0	0.00125
	18...	3000	1206	...	30,900	...	15,200	...	46,100	30,400	0 to -1370	...	23,750	...	0.001525	0.00080	-0.00083	0	0.00125
	19...	P 4000	1526	...	41,200	41,200	0	0	...	20,800	...	0.00193	0.00044	-0.00090	0	0.00177
	20...	500	702	...	5,150	...	21,250	...	21,250	-21,250	0	...	20,800	...	0.00265	0.00077	-0.00083	0	0.00133
								21,250						21,250		0.00137	0.00137	-0.00137	0	0.00285	
IX.	1...	1600	...	355	...	16,900	...	16,900	33,800	0 to -1520	...	17,650	0.000688	0.00090	-0.000725	0	0.000900
	2...	8300	1367	...	34,000	34,000	0	0	...	17,000	...	0.001730	0.001730	-0.002497	0	0.001150	
	3...	3500	950	...	36,000	36,100	0	0	...	18,050	...	0.001202	0.000533	-0.000767	0	0.001220	
	4...	80	633	...	20,000	20,000	-20,000	0	...	20,000	...	0.002390	0.001195	-0.001195	0	0.00096	
	5...	2500	435	...	25,750	22,670	-6,900	0	...	19,800	...	0.001640	0.001437	-0.000667	0	0.001200	
	6...	2500	840	...	25,750	...	10,350	...	36,100	20,700	0 to -935	...	18,500	...	0.001062	0.000925	-0.000184	0	0.000925

TABLE VII.
Results of Tests.—Copper Tubes.

OBSERVATIONS.				CALCULATED STRESSES.							CALCULATED STRAINS.									
Number of Tube.	Fest.	Stress.			Strain.		Applied.			Principal.			Max. Shear.	As Measured.		Maximum Principal Strain calculated from Stresses.	Principal.			Max. Slide.
		P.	W.	P ₀ .	Axial.	Twist.	p.	q.	p ₁ .	σ ₁ .	σ ₂ .	σ ₃ .		Axial.	Twist.		γ ₁ .	γ ₂ .	γ ₃ .	
X.	1	...	35	378	...	6,070	...	6,070	-6,070	0	6,070	...	0-001425	0-000483	0-000712	-0-000712	0	0-001425
	2	1300	612	...	10,630	...	10,630	0	0	0	5,315	0-000786	...	0-000688	0-000786	-0-000432	-0-000432	0-001218
	3	1300	25	...	530	291	9,210	4,370	...	10,950	-1,735	0	6,360	0-000682	0-001095	0-000647	0-000910	-0-000525	-0-000297	0-001435
	4	900	...	700	438	...	6,380	...	5,120	11,500	10,240	0 to -660	6,075	0-000563	...	-0-000523	0-000393	0-00029	-0-000523	0-000910
	5	600	...	900	327	...	4,250	...	6,580	10,830	13,160	0 to -850	7,000	0-000420	...	-0-000478	0-00038	0-000468	-0-000478	0-000946
	6	1700	662	...	12,050	12,050	0	0	6,025	0-000850	...	0-000865	0-000830	-0-00037	-0-00037	0-00122
	7	1800	608	...	12,750	12,750	0	0	6,375	0-000780	...	0-000705	0-000780	-0-00034	-0-00034	0-00112
	8	...	35	341	...	6,070	...	6,070	-6,070	0	6,070	...	0-001285	0-000483	0-000642	-0-000642	0	0-001285
	9	...	25	800	115	255	...	4,370	5,730	13,885	3,355	0 to -740	7,300	0-000148	0-000992	0-000685	-0-00015	0-000685	-0-000412	0-001097
XI.	1	825	136	5,925	5,925	11,850	0 to -750	6,300	0-000173	...	0-000515	0-000045	-0-000515	-0-000423	0-000938
	2	1400	464	...	9,925	9,925	0	0	4,962	0-000595	...	0-000577	0-000595	-0-00026	-0-00026	0-000855
	3	1250	...	525	525	...	8,860	...	3,870	12,730	7,740	0 to -500	6,800	0-000673	...	0-00052	0-00052	0-00012	-0-00049	0-00100
	4	...	35	436	...	6,070	...	6,070	-6,070	0	6,070	...	0-00164	0-000505	0-00082	-0-00082	0	0-00082

TABLE VIII.
Results of Tests.—Brass Tubes.

Number of Tube. Test.	OBSERVATIONS.						CALCULATED STRESSES.										CALCULATED STRAINS.					
	Stress.			Strain.			Applied.			Principal.			As Measured.			Maximum Principal Strain calculated from Stresses.			Principal.			Max. Slide.
	P.	W.	p_0	Axial.	Twist.	p_1	p .	q .	p_1 .	σ_1	σ_2	σ_3 .	Max. Shear.	Axial.	Twist.	Strain calculated from Stresses.	γ_1 .	γ_2 .	γ_3 .	Max. Slide.		
XII.	1 ...	50	525	...	574	...	9,450	...	9,450	-9,450	0	9,450	0'00216	0'000940	0'00108	0	0'00216			
	2 ...	2250	...	1070	17,400	...	17,400	0	0	8,700	...	0'001375	...	0'001160	0'001375	-0'000655	-0'000655	0'001923		
	3 ...	2000	25	...	244	...	15,450	4,500	...	16,850	-1,215	0	8,940	0'001145	0'000918	0'001145	0'001267	-0'000552	-0'000446	0'001850		
	4 ...	1600	40	...	438	...	12,370	7,200	...	14,685	-2,315	0	8,500	0'000962	0'00165	0'001045	0'001353	-0'000776	-0'000385	0'00213		
	5 ...	1750	...	900	857	...	13,520	...	7,250	20,770	14,500	0 to -850	10,800	0'001100	...	0'001075	0'001075	0'000446	-0'001013	0'00209		
	6 ...	1500	...	950	763	...	11,580	...	7,680	19,260	15,360	0 to -900	10,075	0'000680	...	-0'000995	0'000945	0'000550	-0'000995	0'00194		
	7 ...	2600	1087	...	20,100	20,100	0	0	10,050	0'001398	...	0'00134	0'001398	-0'000685	-0'000685	0'002083		
	8	57½	...	645	10,350	...	10,350	-10,350	0	10,350	...	0'00243	0'00103	0'00116	-0'00116	0	0'00243		
	9 ...	1900	40	...	480	...	14,670	7,200	...	17,610	-2,940	0	10,275	0'001053	0'00181	0'001265	0'001485	-0'000854	-0'000422	0'00234		
	10 ...	1500	...	1050	661	...	11,580	...	8,400	19,980	16,800	0 to -985	10,525	0'000850	...	-0'00121	0'00078	-0'000465	-0'00121	0'00199		
	11 ...	1800	...	900	784	...	13,900	...	7,250	21,150	14,500	0 to -850	11,000	0'001005	...	-0'00116	0'00093	0'000272	-0'00116	0'00209		
	12	45	825	118	528	...	8,100	6,520	18,520	1,040	0 to -750	9,100	0'000152	0'00199	0'00120	+0'00120	-0'000534	-0'000636	0'00184		
XIII.	1 ...	1500	...	950	759	...	11,580	...	7,670	19,250	15,340	0 to -900	10,075	0'000975	...	-0'00115	0'000400	0'00080	-0'00115	0'00195		
	2 ...	2300	1042	...	17,750	17,750	0	0	8,875	0'001340	...	0'001205	0'001340	-0'00067	-0'00067	0'00201		
	3 ...	350	45	...	480	8,100	...	8,100	-8,100	0	8,100	...	0'00181	0'000850	0'00090	-0'00090	0	0'00181		

Fig. 15.—Torque Twist Curves for Solid Bar.

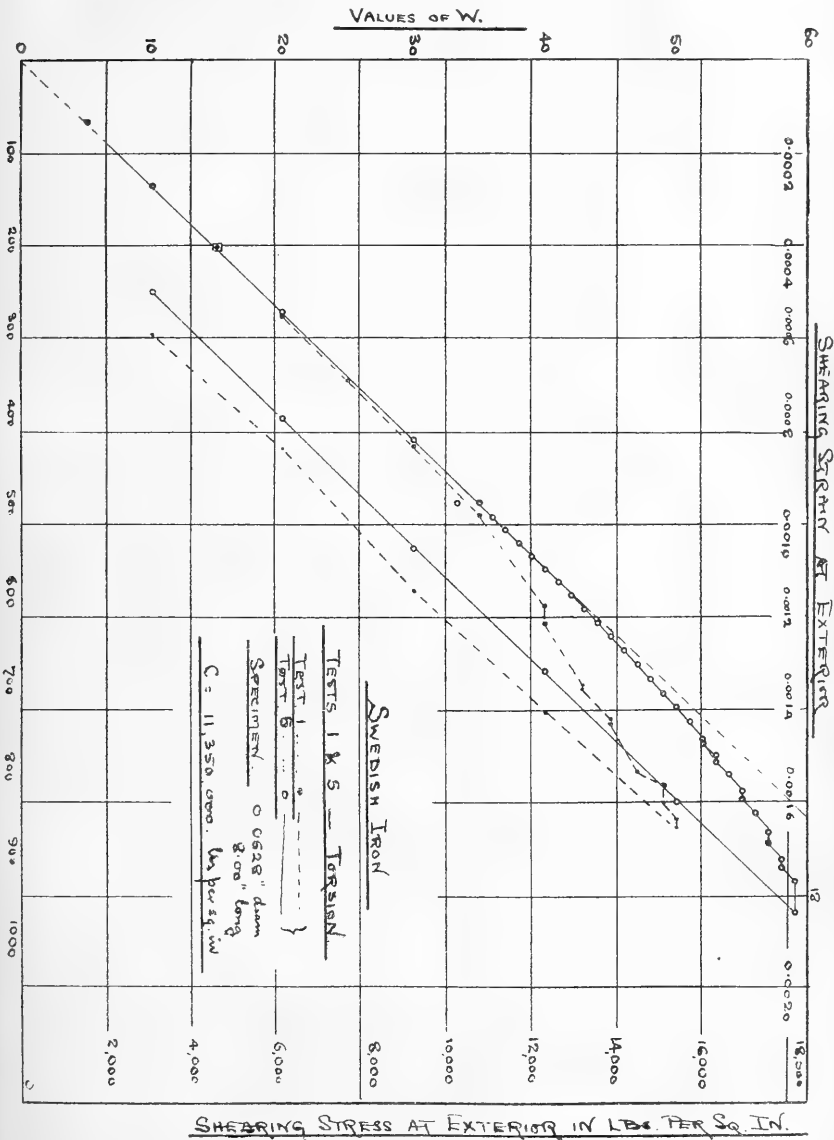

SOME REMINDERS.

FIG 15

47. *The Material and Shape of Tubes satisfactory.*—Turning now to the results of the tube-tests, reference to Table IV. will show that the densities found were high, and that the values of the moduli of elasticity are usual values for the various materials, and certainly not low; also inspection of various stress-strain diagrams indicates that the relation is linear up to a considerable fraction of the yield-point stress. For these reasons the tubes may be taken as of sufficient excellence in material and shape to afford results worthy of consideration.

Few torsion-internal pressure experiments have been performed, but a comparison of results obtained thus with the results of those tests when somewhat similar stresses are differently produced, will tend to cause confidence in the experiments. The torsion-internal pressure tests are Nos. IV. 5, V. 7, VII. 4, X. 9, and XII. 12.

48. *The Elastic-limit Phenomenon.*—The elastic-limit phenomenon, it will be observed, is much decreased in a repetition of a test, the observed strain at the yield-point being less in the second test than in the first, although the stress-strain curves within the elastic limit practically coincide. To illustrate this point some of the tests bearing upon it have been plotted out observation by observation; in figs. 16 and 17 are two sets of tension tests, and in fig. 18 some torsion tests.

When, however, a test imposes upon the material stresses of a different type to those of the preceding test, the elastic-limit effect, which may have temporarily disappeared owing to the similarity of the two preceding tests, is displayed to the full.

Copper seems, however, to harden so much under successive tests, that the strains appear as a whole to lessen with the amount of treatment.

The elastic-limit effect also increases with the number of times different stresses have been applied to the material, as may be seen by comparing the stress-strain curves for tests of the same type, but separated by a number of other tests. Examples are represented in figs. 16 (tension) and 18 (torsion).

This phenomenon may indicate that the cause of failure under comparatively low varying stresses, such as employed by Wöhler in his experiments, is due to gradual increase of size of defects, initially very small; and I think tends to show that the elastic-limit phenomenon is due to the occurrence of the yield-point over small localities.

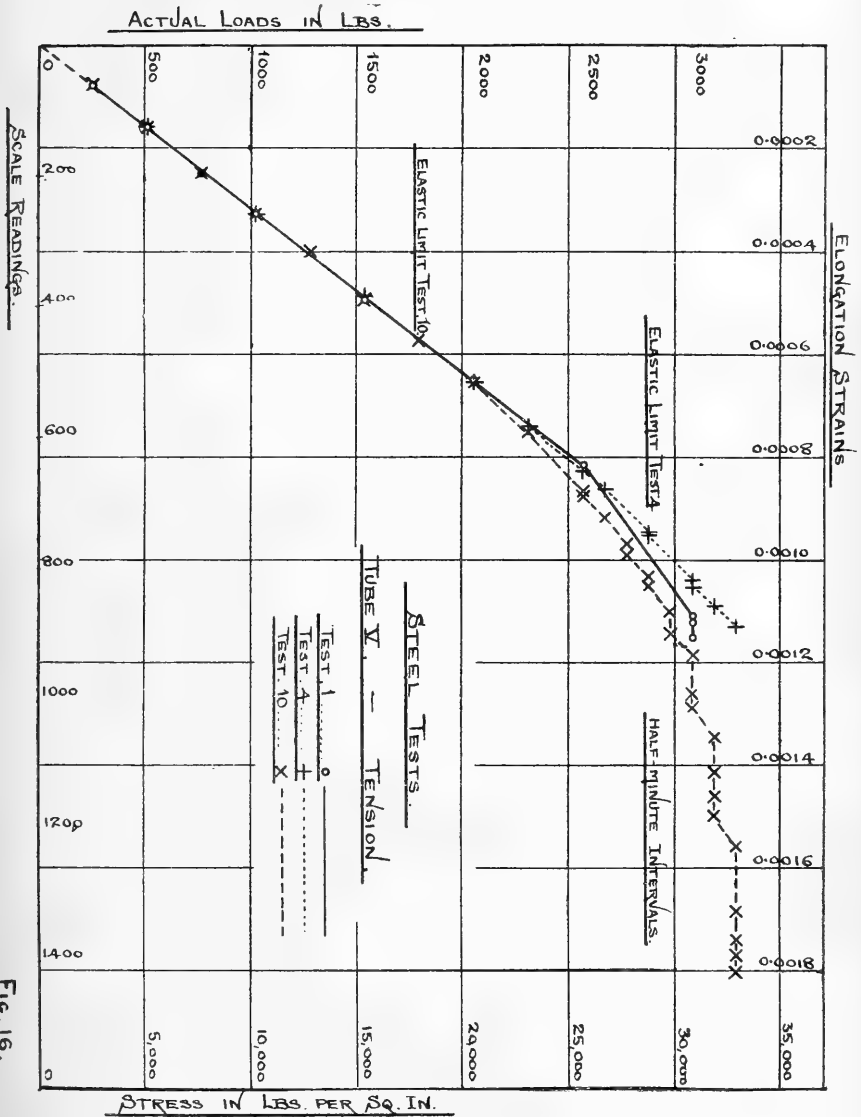

Fig. 16.—Tension Tests on Steel.

Fig. 16.

Fig. 17.—Tension Tests on Steel.

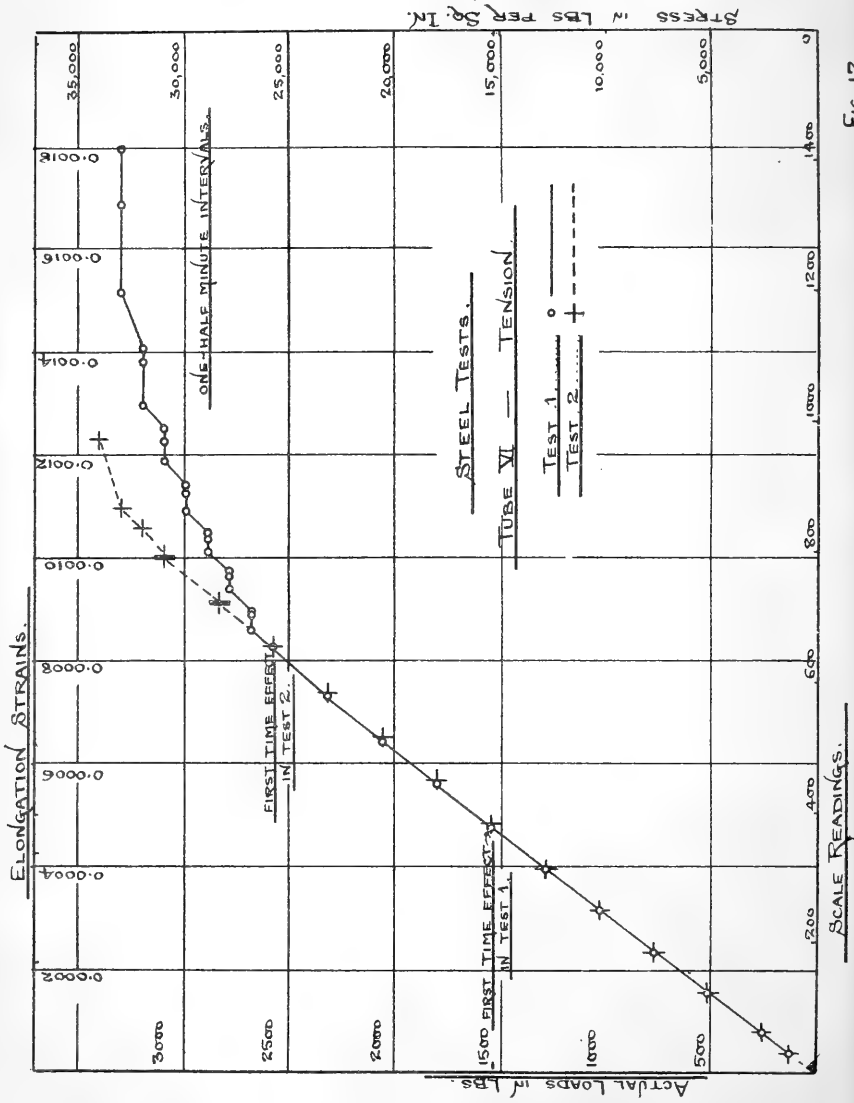

Fig. 17.

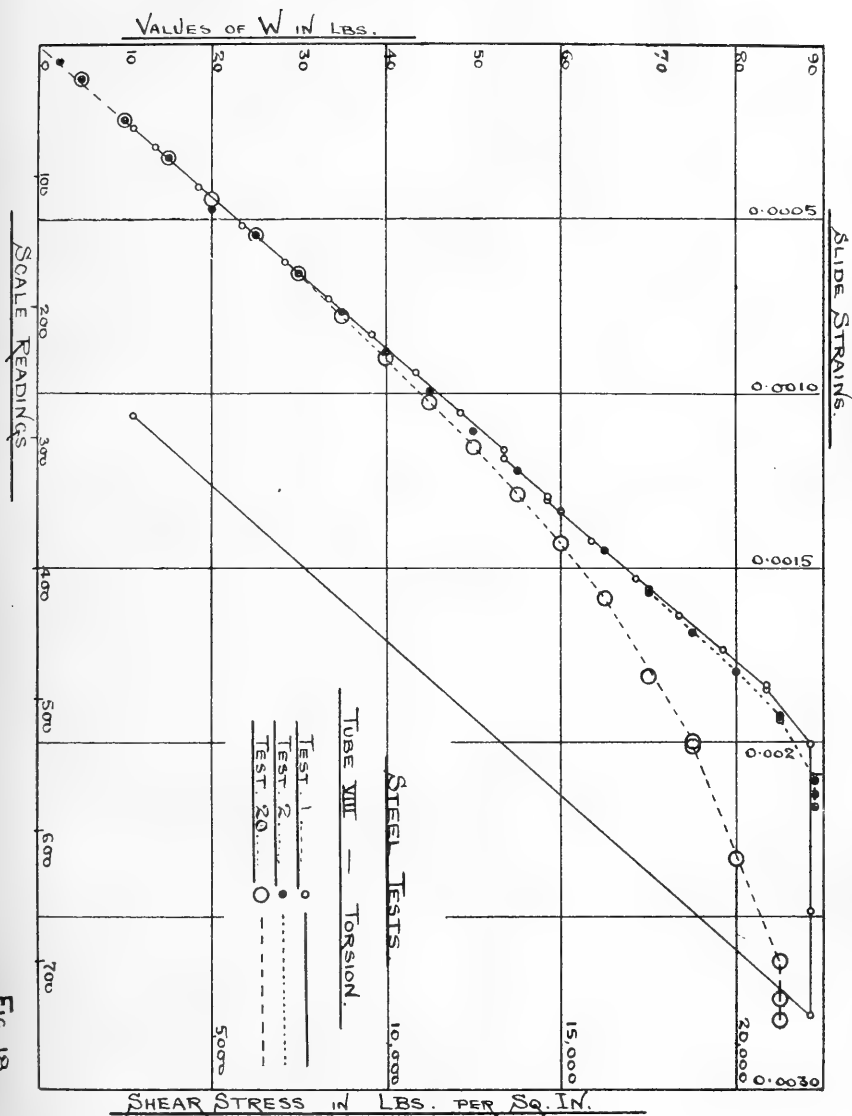

Fig. 18.—Torsion Tests on Steel.

Fig. 18.

49. *Yield-point Stresses of same type nearly constant throughout series on each tube.*—It is to be noted that throughout a series of tests on any tube the yield-point stress never having been much exceeded, it has nearly the same value in tests of the same type, though a series of similar tests tend to cause it to rise.

50. *The Variation of the Maximum Stress.*—Proceeding now to a consideration of the variations of the maximum principal stress, of the maximum principal strain, and of the maximum shearing-stress at the yield-points of the different tests, we find that the first-mentioned varies very largely, its least value being found in the pure torsion tests, while in the tests by tension and internal pressure its value is practically constant, and is the same whether the greater of the principal stresses is axial or circumferential. The experiments on Tubes VII. and VIII. show the latter emphatically. We hence conclude, firstly, that in the case of two tensions (such as in a boiler) the lesser tension does not appreciably affect the yield-point; and, secondly, by the similarity of the yield-point stress, whether the greater tension be axial or circumferential, that the material is practically isotropic in respect to the occurrence of the yield-point,—at any rate as regards the tangent-plane stresses, with which we are most concerned.

51. *Variation of the Maximum Principal Strain.*—The maximum strain at the yield-point varies throughout the experiments: it is greatest in the simple tension experiments, and least either in the torsion tests or when the axial and circumferential tensions are equal. Both the strain as measured (where the axial stress is greatest) and as calculated from the stresses and elastic constants (and so not including the elastic-limit effect) are tabulated and can be compared; the calculated maximum strain is sometimes radial and negative. The variations of the maximum strain from constancy are considerable for all the materials experimented upon.

52. *The Maximum Shearing-Stress or Slide nearly constant.*—The maximum shearing-stress developed, and the corresponding maximum shearing-strain or slide (which are quantities directly proportional and independent of the intermediate principal stress within the elastic limit) are comparatively constant, although the amount is highest in the case of pure torsion and diminishes towards the tension case. It will be remembered that the plane of the maximum shear changes from being a tangential plane of the specimen in the torsion-tension cases to a plane intersecting the axis of the specimen in the tension-internal pressure tests.

The stresses at the elastic limit have been considered in several cases, and have been found to follow the same variations approximately.

53. *Graphical presentation of Variations.*—The tables and figures may be held to prove, in the case of the materials experimented upon—steel, copper and brass—that to a first approximation the shearing-stress is constant whenever the third principal stress is zero, or whenever the lesser principal stress is zero or small.

It can readily be found by trial that no other simple relation between the stresses or strains is approximately constant.

The results of the series of tests upon steel, with the exception of the unannealed specimens, are shown in fig. 19, which has been constructed as follows:— Ox is the axis of principal stress most nearly coinciding with the generators, and the abscissæ represent the relative values of the stresses in the various experiments, a mean axial yield-point stress being selected as the basis of the scale and marked 10. Relative values of the other principal stresses were then set off parallel to Oy and Oz , those parallel to Oy being the mean, and those parallel to Oz being the minimum principal stress. The paper should be now considered as folded at a right-angle along the line Ox ; and the observations recorded in the quadrant zox to lie actually on the paper, while those plotted in the quadrant xoy , though nearly in the plane of the paper, should correctly be considered as projected by lines parallel to Oz on to a plane through Ox inclined to the plane xoy at an angle whose tangent is half the ratio of the internal pressure to the circumferential stress it produces. The value of the angle is about $\tan^{-1} 0.0225$, so that the points may be regarded as practically in the plane of the paper.

On the paper are drawn the lines BAC , BD representing the locus of the points had the maximum stress been true; the lines GAH , KAL , MAN , representing the locus had the maximum strain-law been true, and σ had the values 0.5, 0.25, and 0.356 respectively, the latter being the mean experimental value. The constant shearing-stress law locus is the line $EFABD$, and it will be seen to what extent this agrees with the mean distribution of the observations. No movement of the other lines parallel to themselves can produce any approximation to the mean of the actual distribution.

It must, however, be remembered, while inspecting this figure, that this method of setting out the points was adopted as being just to any theory of strength; had a mean basis been adopted the points could have followed the shearing-stress law much more closely.

Fig. 19.—Synoptical diagram of Tests.

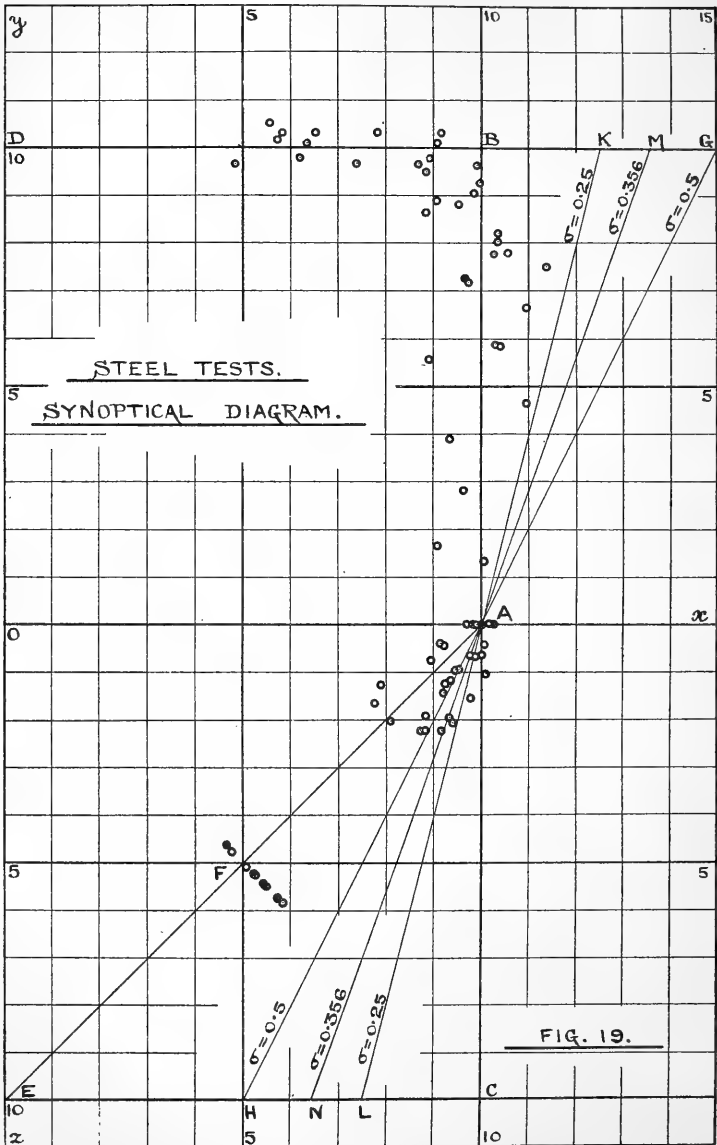

54. *Conclusions probable for general type of Stress.*—Considering the three-dimensional view (fig. 20, p. 93), if the shearing-stress law were true the observations plotted in space between Ox , Oy , Oz , or two tensions and a third stress, would fall upon the two planes, EAB, EDB. We have in our experiments investigated such combinations of stresses as give rise to half the line AE, *i. e.* to FA, to AB, and to BD' which is half BD.

Now a similar figure may be drawn for the strains, and since the traces on the planes $\eta_2=0$ and $\eta_3=0$ in such a figure are straight lines, and since the strains are so small that no quadratic or higher power can have appreciable effect, except in the improbable case of their coefficients being extremely large, the function representing this relation is linear. Since by experiment the value of the intermediate strain has no effect on the yield-point relation, the coefficient of η_2 in the linear relation is zero. The linear relation therefore reduces to the equation of the line AE (or the plane AEB). This line, as determined by experiment, being equally inclined to the axes, the corresponding relation is that the shearing stress or strain is constant.

55. *Effect of a Uniform Volumetric Stress.*—In order to ascertain the relationship of the stresses at the yield-point more accurately, sequences of tests in which torsion and tension combined in various amounts should be compared, and the inclination of the line AE more accurately determined. From this point of view a direct compression-test would be of much assistance. Now the linear relation may be written

$$\varpi_1 - \varpi_2 + \lambda(\varpi_1 + \varpi_2) = C,$$

since this contains two independent constants. Putting $\varpi_2=0$ we get the case of tension only and the yield-point stress from the equation is $\frac{C}{1+\lambda}$. Putting $\varpi_2 = -\varpi_1$ we get the case of pure torsion, and the yield-point stress is then $\frac{1}{2}C$. The mean of the experimental results gives for the ratio of these yield-point stresses the value 0.52, for which the value of λ is 0.04; and the relation becomes

$$\varpi_1 - \varpi_2 + 0.04(\varpi_1 + \varpi_2) = q_0,$$

where q_0 is the value of the yield-point shearing-stress in pure torsion.

56. *Convenient view of general type of Stress.*—Since the stress ellipsoid $\varpi_1x^2 + \varpi_2y^2 + \varpi_3z^2 = 1$, where $\varpi_1, \varpi_2, \varpi_3$ are in

descending order of magnitude, may be written in the form

$$\left(\frac{\varpi_1 + \varpi_2}{2}\right)(x^2 + y^2 + z^2) + \left(\varpi_3 - \frac{\varpi_1 + \varpi_2}{2}\right)z^2 + \frac{\varpi_1 - \varpi_2}{2}xy = 1$$

(since the invariants are the same), it is clear that any state of stress can be represented by the coexistence of a shearing-stress, a volumetric uniform stress, and a stress perpendicular to the plane of the shear; and the yield-point occurs when the shearing-force together with a small fraction of the volumetric stress reaches a certain amount: the volumetric stress being reckoned positive when tensile.

That the coefficient of the volumetric stress for steel is small has been shown by these tests, and that it has some value greater than zero seems probable, as volumetric tension would ultimately reduce the material to the liquid or gaseous form and cause the necessary shear to evanesce. No value can be directly deduced from such considerations owing to lack of knowledge of ultimate molecular action. It may be noted that Bauschinger's experiments on the yield-point in tension and compression, in which the effect of λ would be most marked, would point to zero as its value.

57. *The Copper and Brass Tests, and Diagrams.*—In the case of the copper and brass tests the yield-point is more difficult to locate; the shearing-stress law still appears to be that one of the simple laws nearest to the truth. Taking into account the volumetric stress effect, the coefficient λ is larger than in the case of steel, but so few tests have been made that conclusions should be drawn with hesitation, especially as the yield-point stress tends to rise with the successive tests.

In the copper tests the yield-points were very indefinite, and I have plotted out types of the unusual tests from which the stresses and resulting strains and the mode of their variation can be seen at a glance, and their values at points considered to correspond to the elastic limit or yield-point in the various tests readily compared. These curves are given in figs. 21–24.

In fig. 21 is shown a test under internal pressure only, the stresses parallel to the axis being one-half of the simultaneous circumferential stresses; the values of the internal pressure are laid off along the central line, and the values of the corresponding axial and circumferential strains given on the right and left hand respectively of the figure. The readings of the axial and diametral (fig. 14, p. 93) extensometers are given along the base line, and the corresponding strains along the top of the diagram. The axial strain is laid off positively (extension) towards the right, and the circumferential strain (from the diametral extensometer) positively towards the left.

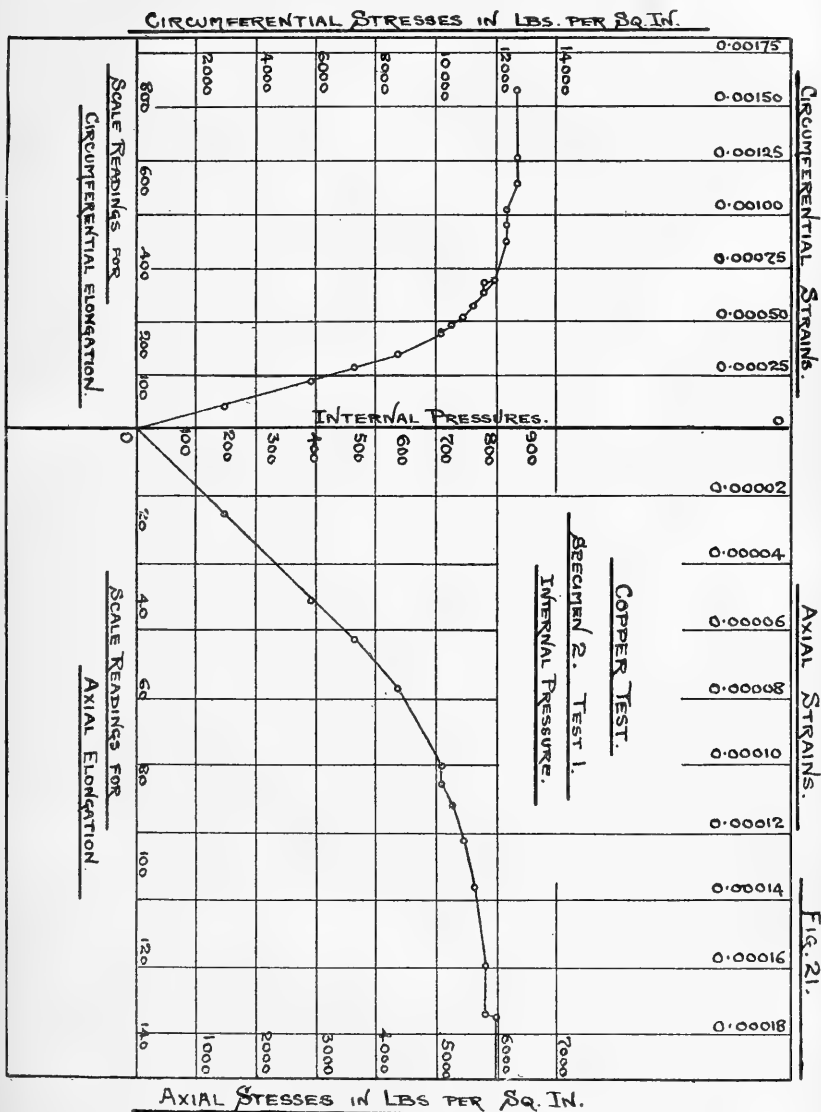

Fig. 21.—Copper Test by Internal Pressure.

Fig. 21.

Fig. 22.—Copper Test by Tension and Internal Pressure.

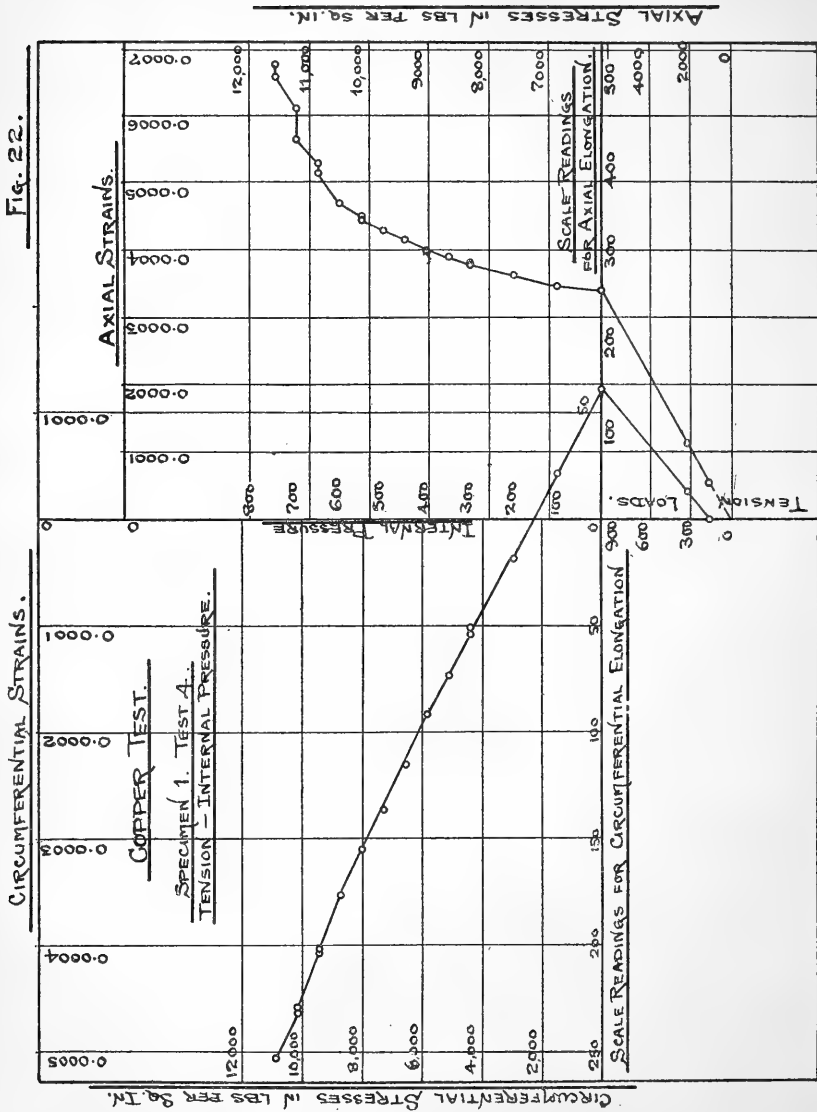

Fig. 22.

Fig. 23.—Copper Test by Tension and Torque.

Fig. 23.

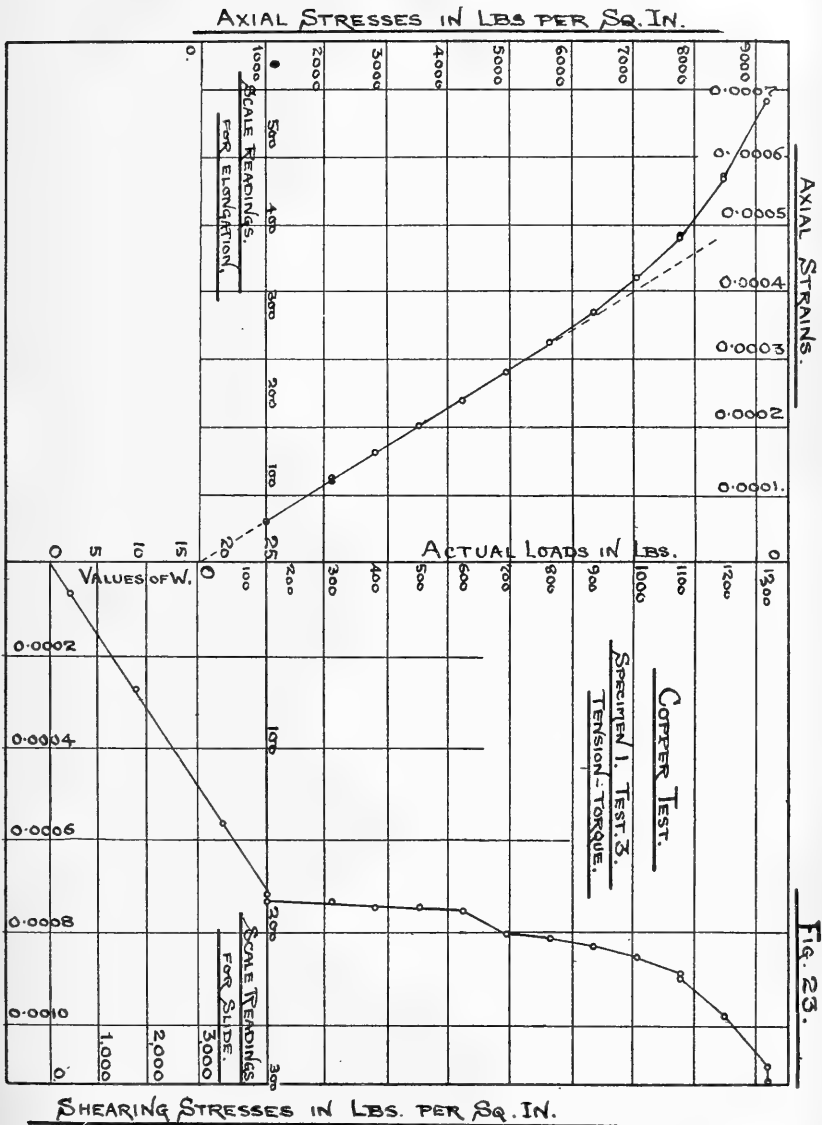

Fig. 24.—Copper Test by Torque and Internal Pressure.

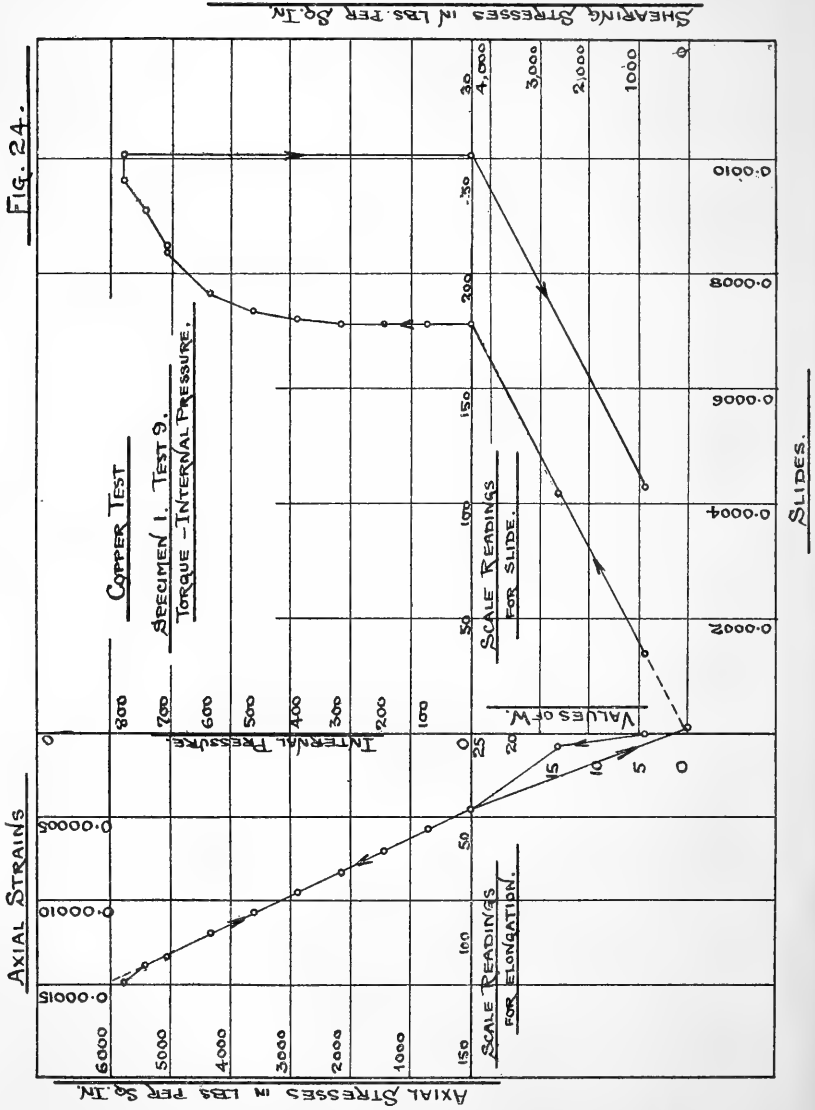

Fig. 24.

SLIDES.

Fig. 22 represents a combined tension and internal pressure test; the tension load was applied first, the actual loads being marked along the central line and the corresponding stresses along the right-hand side line of the figure. The axial strains are positive and are set off to the right of the central line; the circumferential strains (diametral extensometer) are set off positively to the left of the central line, but during the application of the tension loads this strain is negative, and the stress-strain line therefore bears to the right. After a load of 900 lbs., actual, was reached, the tension load was kept constant and the internal pressure applied; the values are marked off along the central line, the resulting circumferential stresses are given on the left-hand, and the total axial stresses on the right-hand of the diagram. Along the line of no internal pressure are given the actual extensometer readings, the corresponding strains being placed at the top.

Fig. 23 represents a combined tension and torsion test; the torque was applied first, and the values of W are set off along the central line and the corresponding stresses on the right-hand side of the diagram. The shearing-strains or slides are set off to the right of the central line. After W had reached the value of 25 lbs., it was kept constant and the tension-loads applied; it will be noticed that the initial tension-load was 150 lbs. The actual tension loads are recorded along the central line, and the corresponding stresses on the left-hand side; the resulting axial strains are positive to the left of the central line. The principal strains at any point cannot be determined at once from the diagram without a construction or calculation. The addition of a tension load should not change the twist (slide) reading, unless the elastic limit has been passed; the slight inclination of this part of the line may be due to a bending-moment, or to a slight want of isotropy introduced by the previous tests.

Fig. 24 is a similar diagram for a torque and internal-pressure test, and can be readily understood from its similarity to the preceding figures.

All these figures, and the corresponding ones for simple tension and torsion, show the stress-strain line as bending gradually over, the strongly-marked yield-point of iron and steel being absent; they also show how unsatisfactory, in such cases, any tabulation of elastic-limit or yield-point stresses and strains must be. The selection of apparently similar points on the curves, however, leads to the discovery at them of the same amount of shearing-stress.

Fig. 25.—Curves showing Variations of Maximum Stress, of Maximum Strain, and Maximum Shear.

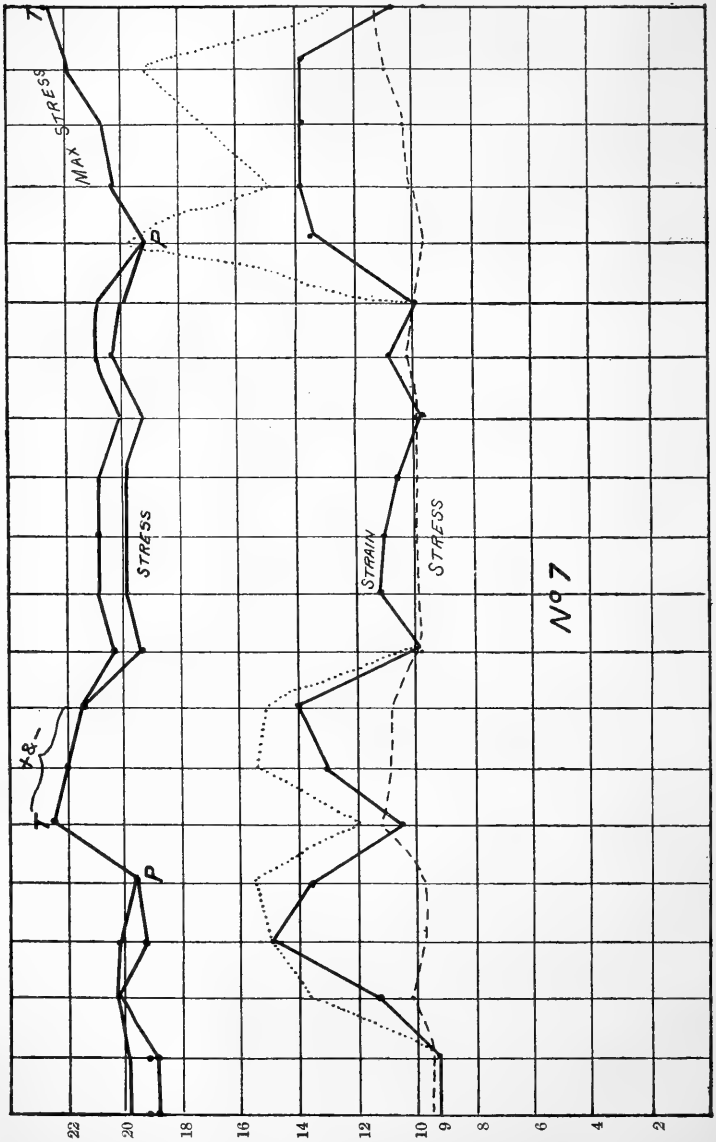

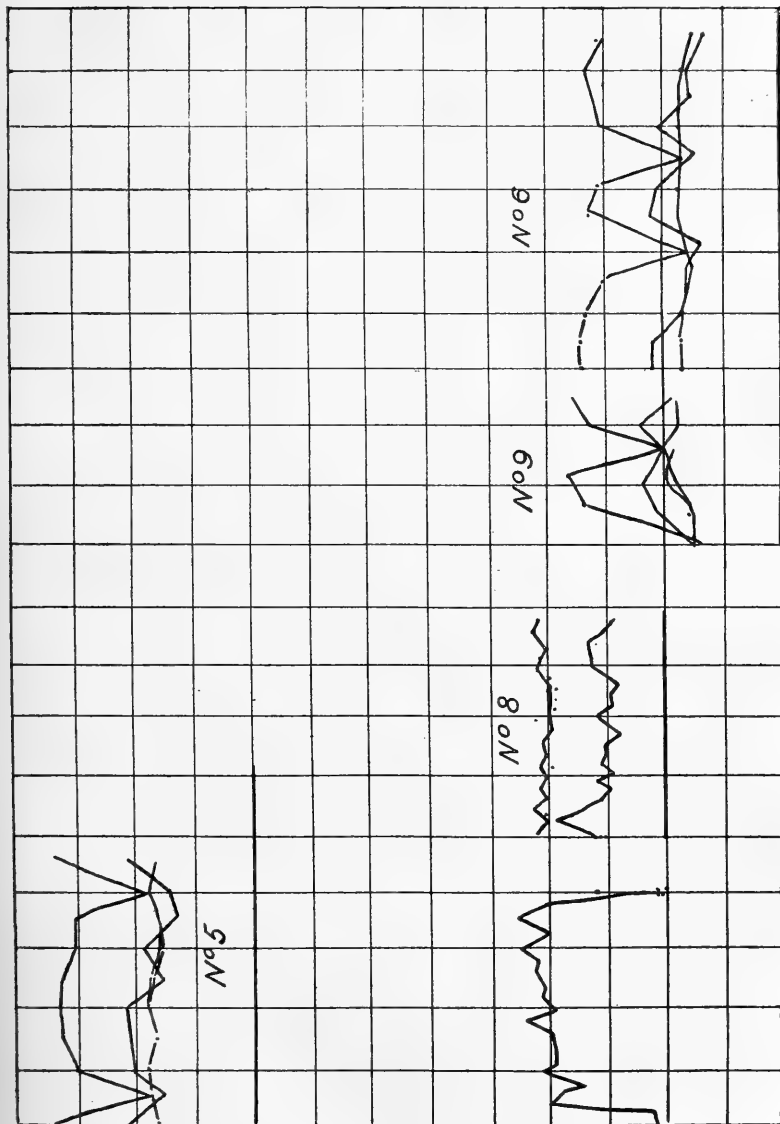

58. *Practical Conclusions and Note.*—The result, then, of these experiments, as applicable to practice, is that the condition for initial yielding of a uniform ductile material is the existence of a specific shearing-stress; and that the intermediate principal stress is without effect.

Note.—Cases of more than one principal stress are met with most frequently in boilers, hydraulic cylinders, and crank-shafts. In the former cases the results obtained above lead to the same dimensions as are obtained by the consideration of the greatest stress only, while the maximum-strain theory would lead to the adoption of too small a thickness. In the case of crank-shafts, or “combined bending and twisting,” both the greatest stress and greatest strain theories lead to too small dimensions, the corresponding well-known formulæ for the “equivalent bending moment” being

$$\frac{1}{2}(M + \sqrt{M^2 + T^2}) \quad \text{and} \quad \frac{3}{8}M + \frac{5}{8}\sqrt{M^2 + T^2}$$

respectively, where M is the applied bending-moment and T the applied twisting-moment. The greatest shearing-stress theory leads to the (greater) value $\sqrt{M^2 + T^2}$ for the equivalent bending-moment, and where the dimensions are thus determined that formula should be used. A lower factor of safety might, however, be used in such cases, where there is a large reserve of understressed material.

It may also be noted that the specific shearing-stress at the yield-point is better determined by taking one half of the tensional yield-point stress, than from the results of torsional experiments in which the sharpness of the yield-point is masked, as explained in § 10 and shown in fig. 15.

[I have pleasure in expressing my thanks for assistance rendered in the tests by Messrs. Ashworth, Howe, Knowles, Rebboli, Nichols, Vail, and Heichert; the latter of whom also assisted me in the construction and erection of the greater part of the apparatus.]

VI. *The Production of the x-Rays by a Battery Current.*

By JOHN TROWBRIDGE*.

I HAVE lately completed the installation of a plant of twenty thousand storage-cells in the Jefferson Physical Laboratory. This gives me over forty thousand volts and a comparatively steady current through a large resistance. One of the most interesting questions in relation to this battery was the possibility or impossibility of producing the

* Communicated by the Author.

x-rays in an efficient manner by means of it. This question has been answered in the affirmative, for the rays are produced with the greatest brilliancy; and it is possible to take photographs of the usual subjects which lend themselves to this method of study. The negatives show strong contrasts, and there are traces of the ligaments and the muscles.

The great advantage of this new method of producing the rays is in the possibility of regulating the current and the difference of potential which is necessary to excite the rays: this is not possible by any of the other methods in present use. When the *x*-ray tube is first connected to the battery-terminals no current flows; it is necessary to heat the tube with a Bunsen burner. At a certain critical temperature the tube suddenly lights with a vivid fluorescence, and when the anticathode glows with a cherry-red the rays are given off with great intensity. I employed a distilled-water resistance of approximately four million ohms in direct circuit with the tube. The current, therefore, was not more than three or four milliamperes. It is an interesting spectacle to see the tube glowing in such a brilliant and noiseless fashion. Since such a large resistance was necessary with the use of forty thousand volts, it seemed possible to excite the rays with fewer cells. Indeed, there is no difficulty in producing them brilliantly with twenty thousand cells; and I see no reason why they cannot be generated by a much smaller number if a suitable tube is employed.

Since I employed four million ohms in circuit with the *x*-ray tube, it is evident that there were no electrical oscillations through this circuit. What is needed for the efficient production of the rays is a current in one direction; a current moreover of sufficient strength to raise the anticathode to a cherry-red. When the anticathode rises to a white heat, the resistance of the tube falls to such a degree, from the gases which are set free from the terminals and the walls of the tube, that the rays are enfeebled. This change of resistance in the tube is a most important phenomenon. It is evidently produced by the outcoming of gases which have been occluded in the metallic terminals and on the glass walls of the tube. Dr. Rollins of Boston has lately described, in the 'Electrical Engineer' for May, what seems to me a crucial experiment in this connexion. Two Röntgen-ray tubes of the ordinary focus-plane pattern were joined together by a cross connexion which was at right angles to the axes of the tubes. The arrangement thus constituted a double *x*-ray tube. This was exhausted to a high degree: the same degree of rarefaction was present in both tubes. One of the tubes was then heated

until a difference of potential competent to produce a spark in air of an inch excited the x -rays with great brilliancy; at the same time a difference of potential giving a spark of eight inches could not produce these rays in the other connecting tube; the same degree of vacuum, so to speak, existed in both tubes. The phenomenon of the occlusion of gases seems to be the controlling one in the production of the rays, and not the degree of exhaustion. With the steady battery-current one can watch this phenomenon to great advantage. When the tube is heated to a certain critical temperature a blue cloud proceeds from the anode, and is met by the cathode-beam from the cathode. If the strength of the current is then gradually increased by diminishing the resistance in the circuit, this blue cloud fills the entire tube: the anticathode grows white hot and the x -rays cease to appear. When the current is diminished the anticathode sinks to a cherry-red, the blue cloud contracts and sinks into the anode, and the x -rays come out with great brilliancy. The disappearance of the blue cloud betokens a rise of resistance in the tube; for the glow on the anticathode grows less and less, and presently, if the current is not increased, the tube is completely extinguished and a reheating is necessary.

A steady battery-current with an adjustable liquid resistance is indispensable, I believe, if we wish to study the best conditions for producing the rays. A storage-battery of forty thousand volts enables me to try a wide range of voltage and current strength; moreover, the radiant point of the rays is less likely to produce ghosts. The tubes appear to glow in a perfectly steady way, and the degree of excitation of the rays seems to be under perfect control. The phenomenon of occlusion in an x -ray tube having such an important bearing on the subject of the passage of gases through a rarefied space, I was interested to trace the phenomenon from a pressure of one or two millimetres up to the x -ray stage. I used for this purpose an end-on tube of a peculiar construction. One end of the tube was blown out into a thin bulb through which the x -rays could be observed. It was possible to heat this tube strongly so as to produce a high state of exhaustion; and this form of tube was very useful in studying the electrical discharges by a spectroscope. When the tube was exhausted to the stratified discharge stage, and was connected to the terminals of the battery, the intensity and form of the stratifications could be changed by increasing or diminishing the strength of the battery-current. When this current was increased, a blue discharge in the form of a stra-

tification detached itself from the anode and joined the stratifications in the narrow portion of the tube. This process could be repeated until there appeared to be formed a species of stationary wave, due apparently to the setting free of the gases from the anode meeting a cathode liberation. When the strength of the current is diminished, the stratifications disappear in the terminals, more noticeably in the anode than in the cathode. This process can be traced to the x -ray stage. Since there are no electrical oscillations in the circuit, for I had several megohms in circuit, the molecular theory of bombardment, together with the phenomenon of occlusion, seem to be most important. The end-on tube which was employed was filled with dry hydrogen obtained by electrolysis from phosphoric acid and distilled water. The gas was passed through caustic potash and phosphoric pentoxide. Hittorf's resistance of iodide of cadmium in amyl alcohol will undoubtedly be better than distilled water in quantitative experiments.

Jefferson Physical Laboratory,
Cambridge, U.S.

VII. *On Approximately Simple Waves.*

By Lord RAYLEIGH, *F.R.S.**

THE first question that arises is as to the character of *absolutely* simple waves; and here "it may be well to emphasize that a simple vibration implies *infinite* continuance, and does not admit of variations of phase or amplitude. To suppose, as is sometimes done in optical speculations, that a train of simple waves may begin at a given epoch, continue for a certain time involving it may be a large number of periods, and ultimately cease, is a contradiction in terms" †. A like contradiction is involved if we speak of unpolarized light as homogeneous, really homogeneous light being necessarily polarized.

This much being understood, approximately simple waves might be defined as waves which *for a considerable succession* deviate but little from a simple train. Under this definition large changes of amplitude and frequency would not be excluded, provided only that they entered slowly enough. More frequently further limitation would be imposed, and approximately simple waves would be understood to mean waves which *for a considerable succession* can be approximately identified with a simple train of given frequency, if not of

* Communicated by the Author.

† 'Theory of Sound,' 2nd ed. § 65 a, 1894.

given amplitude. But the *phase** of the simple train approximately representing the given waves would vary from place to place, slowly indeed but to any extent.

Thus if we take, as analytically expressing the dependence of the displacement upon time,

$$H \cos pt + K \sin pt, \quad (1)$$

where H and K are slowly varying functions of t , the frequency may be regarded as constant, while the amplitude $\surd(H^2 + K^2)$ and the phase $\tan^{-1}(K/H)$ vary slowly but without limit. It scarcely needs to be pointed out that a *slow* uniform progression of phase is equivalent to a *small* change of frequency.

In one important class of cases the phase remains constant and then, since a constant addition to t need not be regarded, (1) is sufficiently represented by

$$H \cos pt \quad (2)$$

simply. If the changes of amplitude are periodic, we may write

$$H = H_0 + H_1 \cos qt + H_1' \sin qt \\ + H_2 \cos 2qt + H_2' \sin 2qt + \dots, \quad . . . (3)$$

in which q is supposed to be small. The vibration (2) is then always equivalent to a combination of simple vibrations of frequencies represented by

$$p, \quad p+q, \quad p-q, \quad p+2q, \quad p-2q, \quad \&c.$$

Under this head may be mentioned the case of ordinary beats, so familiar in Acoustics. Here

$$H = H_1 \cos qt, \quad (4)$$

and $H \cos pt = \frac{1}{2}H_1 \cos (p+q)t + \frac{1}{2}H_1 \cos (p-q)t. \quad . . . (5)$

It may be observed that although the phase is regarded as constant, the change of sign in the amplitude has the same effect as an alteration of phase of 180° .

Another important example is that of intermittent vibrations. If we put

$$H = 2(1 + \cos qt), \quad (6)$$

the amplitude is always of one sign, and

$$H \cos pt = 2 \cos pt + \cos (p+q)t + \cos (p-q)t. \quad . . . (7)$$

Three simple vibrations are here required to represent the effect.

* What is here called for brevity the phase is more properly the *deviation* of phase from that of an absolutely simple train of waves.

Again ('Theory of Sound,' § 65 *a*), if

$$H = 4 \cos^4 qt, \quad (8)$$

we have

$$H \cos pt = \frac{3}{2} \cos pt + \cos (p+q)t + \cos (p-q)t \\ + \frac{1}{4} \cos (p+2q)t + \frac{1}{4} \cos (p-2q)t. \quad . . (9)$$

If *K* also be variable and periodic in the same period as *H*, so that

$$K = K_0 + K_1 \cos qt + K_1' \sin qt \\ + K_2 \cos 2qt + K_2' \sin 2qt + \dots, \quad . . (10)$$

we have the most general periodicity expressed when we substitute these values in (1); and the general conclusion as to the periods of the simple vibrations required to represent the effect remains undisturbed.

If *K* and *H* vary together in such a manner that the amplitude $\sqrt{(H^2 + K^2)}$ remains constant, the sole variation is one of phase. My object at present is to call attention to this class of cases, so far as I know hitherto neglected, unless an example (Phil. Mag. xxxiv. p. 409, 1892) in which an otherwise constant amplitude is periodically and suddenly reversed be considered an exception.

If we take

$$H = \cos (\alpha \sin qt), \quad K = \sin (\alpha \sin qt), \quad . . (11)$$

H and *K* are of the required periodicity, and the condition of a constant amplitude is satisfied. In fact (1) becomes

$$\cos (pt - \alpha \sin qt). \quad (12)$$

Now, since

$$e^{i\alpha \cos \theta} = J_0(\alpha) + 2iJ_1(\alpha) \cos \theta + 2i^2J_2(\alpha) \cos 2\theta + \dots \\ + 2i^nJ_n(\alpha) \cos n\theta + \dots,$$

we have

$$e^{i\alpha \sin qt} = J_0 + 2iJ_1 \sin qt + 2J_2 \cos 2qt + 2iJ_3 \sin 3qt \\ + 2J_4 \cos 4qt + \dots, \quad (13)$$

and thus

$$\cos (\alpha \sin qt) = J_0(\alpha) + 2J_2(\alpha) \cos 2qt + 2J_4(\alpha) \cos 4qt + \dots, \quad (14)$$

$$\sin (\alpha \sin qt) = 2J_1(\alpha) \sin qt + 2J_3(\alpha) \sin 3qt + \dots, \quad . . (15)$$

where *J*₀, *J*₁, &c. denote (as usual) the Bessel's functions of the various orders. In the notation of (3) and (10)

$$H_1 = H_3 = \dots = 0, \quad H_1' = H_2' = H_3' = \dots = 0, \\ H_0 = J_0(\alpha), \quad H_2 = 2J_2(\alpha), \quad H_4 = 2J_4(\alpha), \quad \&c., \\ K_0 = K_1 = K_2 = \dots = 0, \quad K_2' = K_4' = \dots = 0, \\ K_1' = 2J_1(\alpha), \quad K_3' = 2J_3(\alpha), \quad K_5' = 2J_5(\alpha), \quad \&c.$$

Accordingly (12), expressed as a combination of simple waves, is

$$\begin{aligned} & J_0(\alpha) \cos pt + J_2(\alpha) \{ \cos (p-2q)t + \cos (p+2q)t \} \\ & \quad + J_4(\alpha) \{ \cos (p+4q)t + \cos (p-4q)t \} + \dots \\ & \quad + J_1(\alpha) \{ \cos (p-q)t - \cos (p+q)t \} \\ & \quad + J_3(\alpha) \{ \cos (p-3q)t - \cos (p+3q)t \} + \dots \quad (16) \end{aligned}$$

If α , representing the maximum disturbance of phase, be small, we may write approximately

$$J_0 = 1 - \frac{1}{4}\alpha^2, \quad J_1 = \frac{1}{2}\alpha, \quad J_2 = \frac{1}{8}\alpha^2,$$

n .	J_n (3).	J_n (6).	J_n (12).	J_n (18).	J_n (24).
0	-.26005	+.15065	+.04769	-.01336	-.05623
1	+.33906	-.27668	-.22345	-.18799	-.15404
2	+.48609	-.24287	-.08493	-.00753	+.04339
3	+.20906	+.11477	+.19514	+ 18632	+ 16127
4	+.13203	+.35764	+.18250	+.06964	-.00308
5	+.04303	+.36209	-.07347	-.15537	-.16230
6	+.01139	+.24584	-.24372	-.15596	-.06455
7	+.00255	+.12959	-.17025	+.05140	+ 13002
8	+.00049	+.05653	+ 04510	+ 19593	+ 14039
9	+.00008	+.02117	+ 23038	+ 12276	-.03643
10	+.00001	+.00696	+ 30048	-.07317	-.16771
11	+.00205	+ 27041	-.20406	-.10333
12	+.00055	+ 19528	-.17624	+ 07299
13	+.00013	+ 12015	-.03092	+ 17632
14	+.00003	+ 06504	+ 13157	+ 11803
15	+.00001	+ 03161	+ 23559	-.03863
16	+ 01399	+ 26108	-.16631
17	+ 00570	+ 22855	-.18312
18	+ 00215	+ 17063	-.09311
19	+ 00076	+ 11271	+ 04345
20	+ 00025	+ 06731	+ 16191
21	+ 00008	+ 03686	+ 22640
22	+ 00002	+ 01871	+ 23429
23	+ 00001	+ 00886	+ 20313
24	+ 00395	+ 15504
25	+ 00166	+ 10695
26	+ 00066	+ 06778
27	+ 00025	+ 03990
28	+ 00009	+ 02200
29	+ 00003	+ 01143
30	+ 00001	+ 00563
31	+ 00263
32	+ 00118
33	+ 00000
34	+ 00021
35	+ 00008
36	+ 00003
37	+ 00001

while J_3 &c. are of higher powers in α than α^2 . Thus if we stop at the first power of α , we are concerned only with the multiples of t represented by

$$p, p - q, p + q;$$

while if we include α^2 we have

$$p, p - q, p + q, p - 2q, p + 2q.$$

But when α is not small, the convergence is slow, and a large number of terms will be required even for a moderately close approximation. The preceding table, due to Meissel, is condensed from Gray and Mathew's 'Bessel's Functions.' So far as π can be identified with β , the values of α equal to 3, 6, 12, 18, 24 correspond to maximum deviations of phase (in both directions) equal to $\frac{1}{2}, 1, 2, 3, 4$ periods respectively. It appears that the largest value of $J_n(\alpha)$ occurs for a value of n somewhat less than α . Indeed, it is at once evident from (12) that frequencies in the neighbourhood of $p \pm q\alpha$ will be important elements.

VIII. *The Spark-Length of an Induction-Coil.*

By R. BEATTIE, B.Sc.*

IN an ordinary induction-coil the relationship of the secondary spark-length to the conditions which obtain at the primary break has, at one time or another, received a good deal of attention; and most of the facts which are likely to have any bearing on the action of the coil are well enough known. On one or two minor points, however, no very accurate or detailed data appear to exist. For instance, although Rijke † has studied the effect on the secondary spark-length of using different materials as the primary poles, and although he has indicated in a general way the influence of rate of separation of the primary poles, yet his experiments were incomplete in many respects. In making the experiments described in the present paper, the object was to extend Rijke's results, and to examine more fully how the length of the secondary spark depends upon the nature of the primary poles, the rate of break, and the electromotive force in the primary circuit (1) with no condenser across the break, (2) with condensers of various capacities across the break.

Apparatus.—The coil used for the purpose of the experiments was one by Apps, giving normally a 25 cm. spark.

Throughout the experiments the current made or broken

* Communicated by the Author.

† Rijke, Pogg. *Ann.* vol. xcvii. p. 75.

in the primary was always 2.5 amperes, supplied from a battery of secondary cells. The electromotive force could thus be altered by varying the number of cells, and the current was adjusted to its proper value by the introduction of sufficient non-inductive resistance. The primary, therefore, formed part of a circuit carrying, when closed, always the same current of 2.5 amperes, and having always the same inductance (of about 0.4 henry), but whose resistance varied in proportion to the electromotive force acting in it.

In place of the usual vibrating interrupter a special contact-breaker was employed, by means of which the primary poles could be separated either slowly or quickly as desired. The essential parts of this arrangement are shown diagrammatically in fig. 1. A light lever OP_1 , hinged so

Fig. 1.

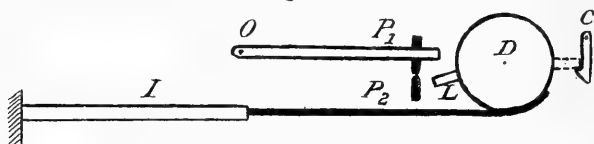

that it can turn about one end O , carries at the other end one of the primary poles P_1 . Immediately underneath is the second pole P_2 . The two are kept in contact and the circuit closed by the weight of the lever. To break the circuit a wooden disk, capable of rotating round its axis D , is furnished with a radially-projecting metal lug L , and has a point on its rim connected by cord with a rubber band I . By rotating the disk counter-clockwise till the lug engages the catch C , the rubber is stretched, so that, on release, the disk flies round and the lug delivers a blow to the end of the lever, thereby separating the poles with a rapidity governed by the initial tension of the rubber.

In what follows, three different rates of break are referred to, viz. slow, moderately quick, and very quick; and in the curves afterwards given these are denoted by the numerals I., II., III. respectively. The slow break was produced by raising the lever rather slowly by hand, no great care being taken to separate the poles always at precisely the same rate, as it was soon found that, up to a certain point, rate of break has little influence on spark-length. The quick breaks were obtained by the mechanical throw-up arrangement, the moderately quick and the very quick breaks corresponding to lug-velocities of about 8 and 18 metres per second at the moment of impact.

As secondary poles the blunt polished points of the coil

discharge-rods were utilized, and the secondary spark-length was taken to be the distance between these poles when so adjusted that the number of sparks amounted to one-half the number of makes or breaks of the primary.

Make-Sparks.—For a given current established in the primary, the only thing that can affect the length of the make-spark of an induction-coil is the magnitude of the electromotive force employed to produce the current. An increase in the primary electromotive force requires an increase in the resistance to keep down the current to its former value. This means a primary circuit with a smaller time-constant, which, in turn, entails a more rapid rise of current, a greater induced electromotive force, and consequently a longer secondary spark. High primary electromotive force must therefore correspond to long secondary spark at make; in fact, as the numbers of Table I. and the dotted curves in figs. 2 and 3 show, there exists a rough proportionality between the two.

TABLE I.—Make-Sparks.

Current made in primary = 2.5 amperes.

Primary E.M.F. in Volts.	Secondary Spark-length in millimetres.
10	.3
20	1.0
30	2.0
38	2.6
50	4.1
70	6.5
80	7.6
95	9.0

Break-Sparks without Condenser.—When, however, a given primary current is interrupted by breaking the circuit, there are several circumstances which unite in determining the length of the secondary spark, viz., (1) the material of the primary poles, (2) the suddenness with which the primary poles are separated, and (3) the magnitude of the electromotive force used to produce the current. Exactly in what way each of these exerts an influence may be gathered from the results collected together in Table II., from which the full-line curves of figs. 2 and 3 have been plotted.

Fig. 2.—Platinum Poles.

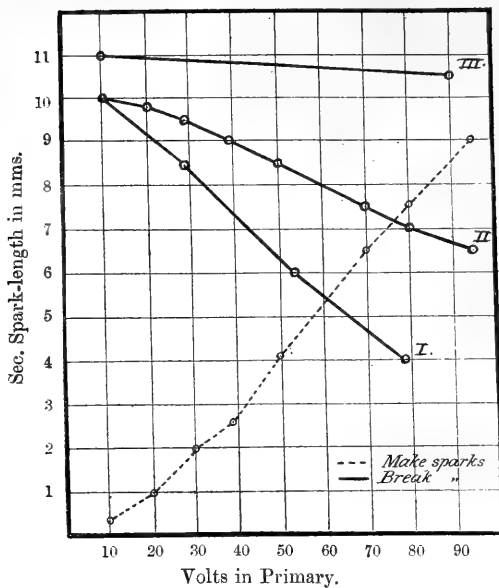

Fig. 3.—Carbon Poles.

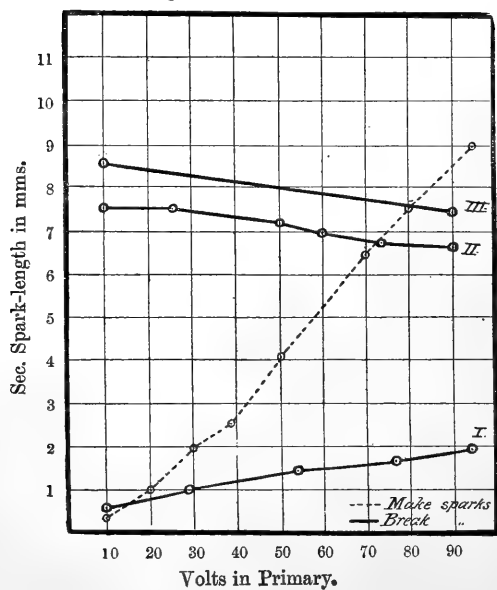

TABLE II.—Break-Sparks without Condenser.

Current broken in primary = 2.5 amperes.

Material of Primary Poles.	Primary E.M.F. in Volts.	Secondary Spark-length in Millimetres.		
		I. Slow Break.	II. Moderately Quick Break.	III. Very Quick Break.
Platinum.	10	10.0	9.9	11.0
	20	...	9.75	
	28	8.5	9.5	
	38	...	9.0	
	50	...	8.5	
	54	6.0	...	
	70	...	7.5	
	78	4.0	...	
	80	...	7.0	
	90	
95	...	6.5	10.5	
Carbon.	10	.5	7.5	8.5
	26	...	7.5	
	28	1.0	...	
	50	...	7.25	
	54	1.5	...	
	60	...	7.0	
	74	...	6.8	
	77	1.75	...	
	90	...	6.7	
	95	2.0	...	
Zinc.	10	.3	7.5	9.5
	76	...	6.25	8.75
	95	2.0
Lead.	10	.3	3.0	8.5
	68	.5	...	7.5
	80	...	2.0	...
Copper.	10	2.3	7.75	10.5
	68	1.75	7.25	9.5
Mercury and Platinum.	10	5.0	12.5	14.5
	72	6.5	10.5	12.0
Mercury and Platinum under Alcohol.	10	7.0	19.0	22.0
	72	8.0	19.5	22.0

As regards the material of the poles, for instance, it is seen that, other things (rate of break and electromotive force) being the same, some substances (like platinum) give a much longer spark than others (as carbon). This, of course, is a well enough known fact, the explanation of which is not far to seek: it is a result of carbon being a readily disintegrating or easily arcing substance, and so setting up at the primary break a heavy arc which, by bridging across the gap, renders the rupture less abrupt.

Again, with respect to rate of break, it is seen that a quick break corresponds to a long and a slow break to a short spark. This, too, can readily be understood; but it is not so easy to comprehend the part played by the primary electromotive force in determining the length of the break-spark. It might be expected that the existence of a high electromotive force in the primary, by causing the arc set up at the primary break to be maintained for a longer period, would result in a short secondary spark. Nevertheless, the experiments show that this is not invariably the case; but that while platinum and copper poles behave in the way anticipated, and give a shortened secondary spark for an increased primary electromotive force, yet carbon, zinc, and lead poles behave differently, for with them the spark-length sometimes, *i. e.* when the break is slow, actually increases as the electromotive force is raised.

The curves of figs. 2 and 3 further serve to bring out the relation between the lengths of the make and break sparks, and so help to indicate, amongst other things, the limitations to the truth of the statement that the break-spark is longer than the make-spark.

Break-Sparks with Condenser.—By the introduction of a condenser in parallel with the primary break the length of the secondary spark is, as a rule, much enhanced. It has long been established, however, that there is a best value for the capacity of the condenser which gives a maximum length of spark. Experiments have been made by Mizuno* which show how the value of this “best capacity” and the length of spark corresponding to it depend upon the magnitude of the current interrupted in the primary. But it may still be asked: For a given current broken in the primary, how do the best capacity and the maximum spark-length depend on the primary electromotive force, on the material of the primary poles, and on the rate of break? An answer, in part at least, to some of these questions is supplied by the results contained in Table III., and illustrated in figs. 4, 5, and 6

* Phil. Mag., May 1898.

TABLE III.—Break-Sparks with Condenser.

Current broken in primary = 2.5 amperes.

Material of Primary Poles.	Capacity in Microfarads.	Secondary Spark-length in Millimetres.		
		I. Slow Break.	II. Moderately Quick Break.	III. Very Quick Break.
Platinum.	0	8.5	9.5	11
	.04	22.0	Same as for slow break.	Same as for slow break.
	.07	27.0	"	"
	.10	29.0	"	"
	.13	28.5	"	"
	.27	28.5	"	"
	.44	27.5	"	"
	1.04	24.0	"	"
1.54	22.0	"	"	
Platinum and Mercury under Alcohol.	0	7.0	19	22
	.07	27.0	Same as for slow break.	Same as for slow break.
	.13	28.5	"	"
	.27	29.0	"	"
	.44	28.0	"	"
	.60	27.0	"	"
	.90	25.0	"	"
	1.54	22.5	"	"
Copper.	0	2.0	7.5	10
	.04	10.0	11.5	Same as for mod. quick. bk.
	.07	19.0	24.0	"
	.13	24.0	27.0	"
	.27	26.5	29.0	"
	.44	27.0	28.5	"
	.90	24.5	26.0	"
	1.54	21.5	23.0	"
Carbon.	0	1.0	7.5	8.25
	.13	1.2	9.5	11.0
	.27	1.35	18.0	19.0
	.44	2.8	22.0	23.0
	.60	5.1		
	.77	9.0		
	.90	...	22.0	23.0
	1.04	12.0		
1.21	12.0			
1.54	11.25	20.0	21.0	
Zinc.	0	1.0	7.2	9.2
	.04	6.5		
	.07	8.75		
	.13	11.5	9.5	11.0
	.27	14.0	13.5	15.0
	.44	15.0	22.0	
	.47	20.0
	.60	...	22.5	25.0
	.77	25.0
	.90	13.5	20.0	
	1.10	22.0
	1.54	12.0	16.0	19.0

Fig. 4.—Platinum and Carbon Poles.

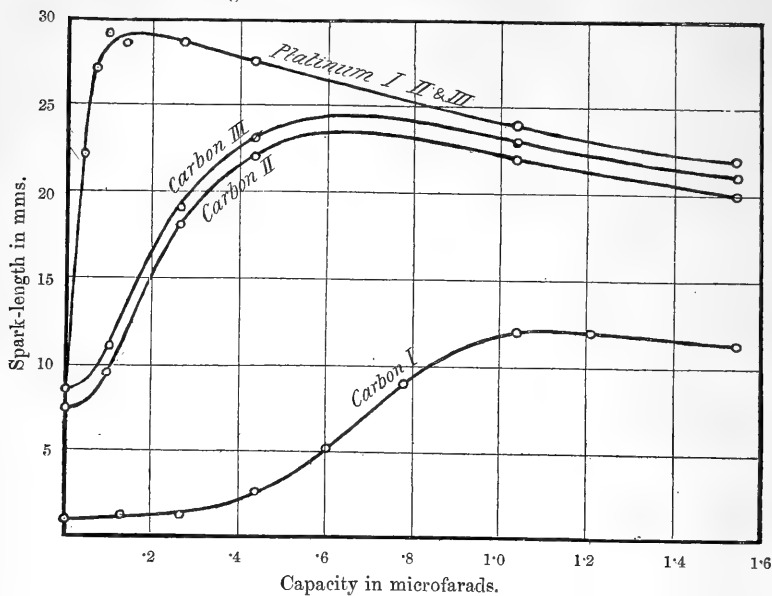

Fig. 5.—Copper Poles.

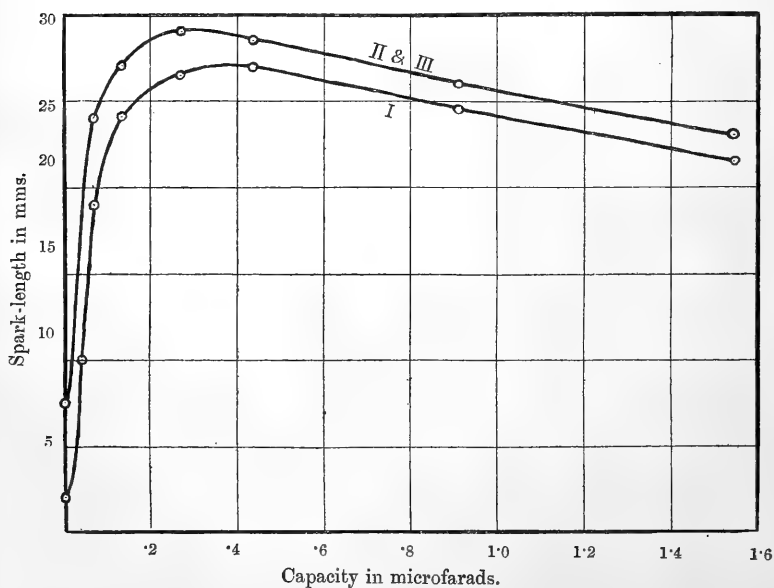
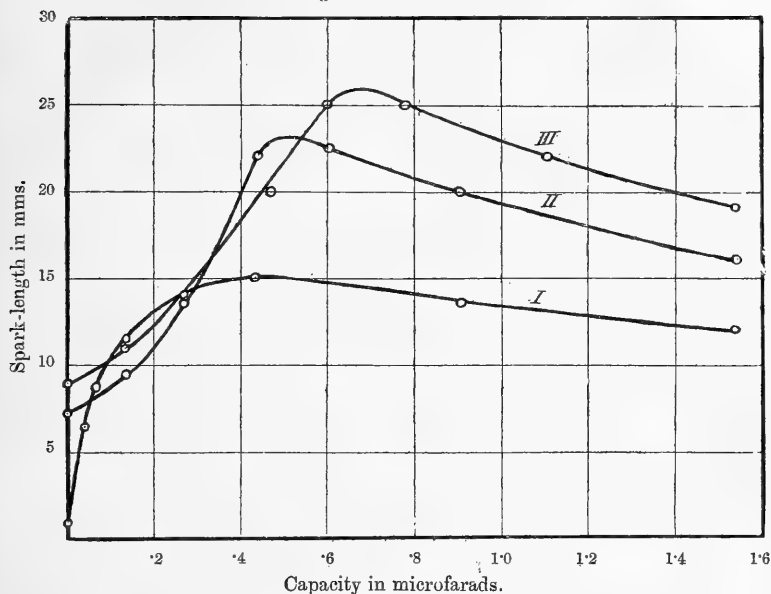

Fig. 6.—Zinc Poles.



by curves which connect the spark-length with the capacity for different rates of break and for several different materials.

As far as the influence of the primary electromotive force is concerned, it seems to matter little whether a high or a low electromotive force is used. At all events, I found that, so long as the capacity of the condenser was anything appreciable, it made no difference to the length of the spark whether I used 10 or 100 volts to produce the primary current of 2.5 amperes. Accordingly, over the somewhat narrow range which these experiments cover, the best capacity, as well as the maximum spark-length, is independent of the primary electromotive force.

On the other hand, both best capacity and maximum spark-length are very greatly affected by the nature of the primary poles. Speaking broadly, we may say that the more easily disintegrable the character of the poles the greater is the capacity needed to give the longest possible spark. Thus, with a slow break, the values in microfarads of the best capacities are:—for platinum .15, for copper .38, for zinc .45, and for carbon 1.1; the corresponding spark-lengths being 29, 27, 15, and 12 millimetres respectively.

Turning, lastly, to examine the effect of varying the rate of break, we observe that the tendency is for the best capacity to decrease and the maximum spark-length to increase as the

break is quickened. This is best seen with carbon, less distinctly with copper, while with platinum-platinum and platinum-mercury breaks the best capacity and the maximum spark-length appear to be unaffected by the quickness of the break. But the behaviour of zinc is altogether anomalous; for with this metal an increase in the quickness of the break is accompanied by an increase in the best capacity, and, moreover, the way in which the curves of fig. 6 intersect each other shows that for certain capacities a quick break may actually give a shorter spark than a slow break. This peculiar behaviour of zinc when used as a break-pole is probably connected in some way with its non-arcing properties.

IX. *Photography of Sound-waves, and the Kinematographic Demonstration of the Evolutions of Reflected Wave-fronts.*
By R. W. WOOD, Assistant Professor of Physics in the University of Wisconsin*.

IN a paper published in the 'Philosophical Magazine' (August 1899) I gave an account of a series of photographs of sound-waves undergoing reflexion, refraction, diffraction, &c., which were made chiefly for the purpose of illustrating certain optical phenomena to classes.

The waves were in every case single pulses in the air produced by electric sparks, illuminated and photographed by the light of a second spark, properly timed with reference to the first, the apparatus being essentially the same as that employed by Toepler for the study of striæ.

I have recently secured, by means of an improved apparatus, a very much better and more complete series of photographs. A silvered mirror of eight inches aperture was used instead of the achromatic lens. This arrangement was used by Mach for a similar purpose, and has certain advantages. Instead of allowing a torrent of sparks to pass between the terminals and receiving the images on a moving plate, as before, single sparks were used and the plate advanced a sufficient distance after each discharge. This eliminated the hot-air currents from the pictures entirely, the heated air not having time to rise from behind the ball terminal, before the picture is taken. At the risk of subjecting myself to criticism for bringing matter already published to the attention of the Society, I wish to devote a few minutes to a very rapid inspection of them.

The following cases, that were not represented in my first paper, I think I may safely comment upon.

The conjugate foci of the elliptical mirror, aplanatic for

* Communicated by the Author, having been read before the Royal Society, Feb. 15, 1900.

rays issuing from a point, is very beautifully shown, the spherical wave diverging from one focus being transformed by reflexion into a converging sphere which shrinks to a point at the other focus.

The transformation of a spherical into a plane wave by a parabolic mirror is also well shown (fig. 1).

Fig. 1.

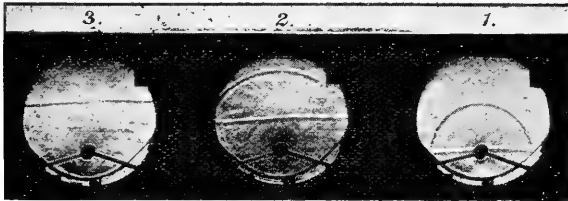

The effect of spherical aberration of circular mirrors is beautifully exhibited in several cases.

When a plane wave enters a hemispherical mirror the reflected wave-front is cusped, and the cusp will be seen to lie always on the caustic surface. The form of the complete wave in this case is not unlike a volcanic cone with a bowl-shaped crater, the bowl eventually collapsing to a point, at

Fig. 2.

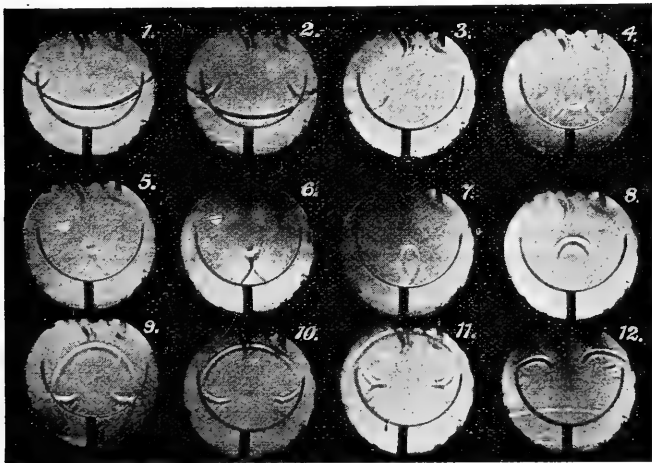

the focus of the mirror, the sides of the cone running in under it and crossing. From now on the wave diverges, and goes out of the mirror in a form somewhat resembling the bell of a medusa, the caustic form by twice reflected rays being traced by a second cusp (fig. 2).

These forms can, of course, be constructed geometrically, and we have here a slide with a number of successive positions of the wave-front, showing how the cusps follow the caustic surface (fig. 3). The construction shows that there is a

Fig. 3.



concentration of energy at the cusp ; consequently we may define the cusp as a moving focus, and the caustic as the surface traced by it. Though I hesitate in claiming that this relation, at once so apparent, is at all novel, I may say that, so far as I have been able to find, it is not brought out in any of the text-books, caustic surfaces being invariably treated by *ray* rather than by *wave-front* methods.

If the wave starts at the principal focus of a hemispherical mirror, the reflected front is nearly plane in the vicinity of the axis, curling up at the edges, however. As this flat-bottomed saucer moves up, the curved sides come to a focus along the circular edge of the flat bottom, so that in one

Fig. 4.

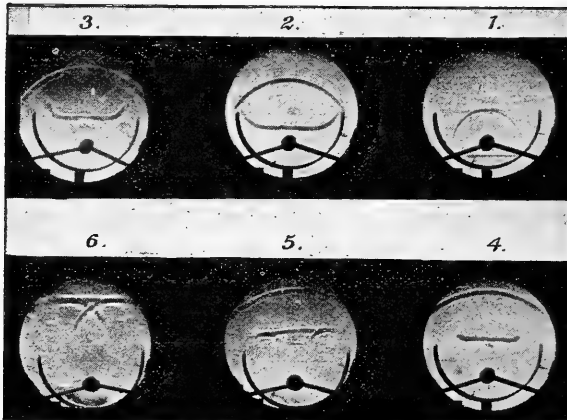

position the front appears as a true plane (fig. 4) ; but from this point on the curved sides, having passed through a focus, diverge again and follow the flat bottom. The cusp formed by the union of these two portions traces the caustic surface,

which is in this case a very tapering funnel, as is shown well by the geometrical construction (fig. 5).

Fig. 5.

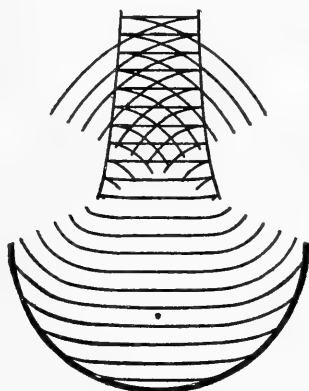

In the stage where the curved sides of the saucer have come to a focus, we must have a ring of condensed air, surrounding a somewhat less condensed circular sheet; and it seems not unlikely that this ring could be photographed, in an oblique direction, appearing on the plate as an ellipse. Its optical analogy can be very nicely shown by cutting a large round-bottomed flask in two, and silvering it, forming in this way a fairly good hemispherical mirror. A small source of light is mounted in the principal focus, and on holding a sheet of ground glass a little outside of the centre of curvature, a brilliant ring of light appears on it. Small electric sparks from a coil and leyden-jar, or a pea incandescent lamp, make a suitable light source.

If, now, we substitute for the hemisphere a complete sphere, we obtain very complex forms which cannot be followed except by geometrical constructions, for the wave is shut up in the mirror and reflected back and forth, becoming more complicated at each reflexion (fig. 6). That all of these very intricate forms can be constructed by geometry I shall show presently; and by means of the animatograph, which Mr. Paul has most kindly placed at our disposal, we can actually see the wave going through its gymnastics.

The principle of Huygens, that any small portion of a wave-front can be considered as the centre of a secondary disturbance, and that a small portion of this new disturbance can in turn be regarded as a new centre, can be shown by the sound-waves, as well as the obliteration of the shadow

by diffraction, and the secondary wavelets reflected from corrugated surfaces, interesting in connexion with the diffraction-grating.

Fig. 6.

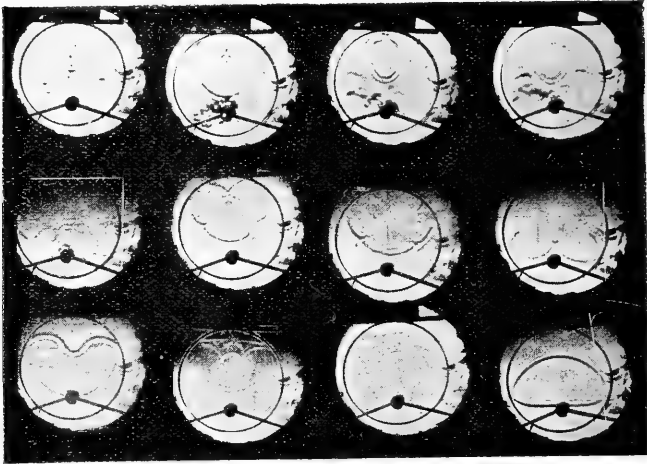

Various cases of refraction are also shown, the only novel one being the transformation of a spherical into a plane wave by a carbonic-acid lens. The construction of the cylindrical lens, of exceedingly thin collodion, a matter of considerable difficulty, was successfully accomplished, the circular flat ends of very thin mica, free from striæ, enabling the passage of the wave through the lens to be followed (fig. 7). The

Fig. 7.

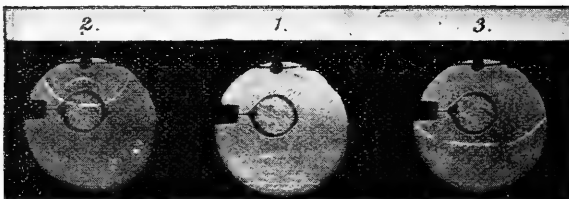

other cases of refraction have already been described, as well as the very beautiful instance of the formation of a train of waves, or musical note, by the reflexion of a single pulse from a steep flight of steps (fig. 8).

Returning now to the evolutions of plane and spherical waves after reflexion from spherical surfaces, I wish to bring to the attention of the Society a method of demonstrating in a most graphic manner the progressive changes in the wave-front reflected under these conditions.

Fig. 8.

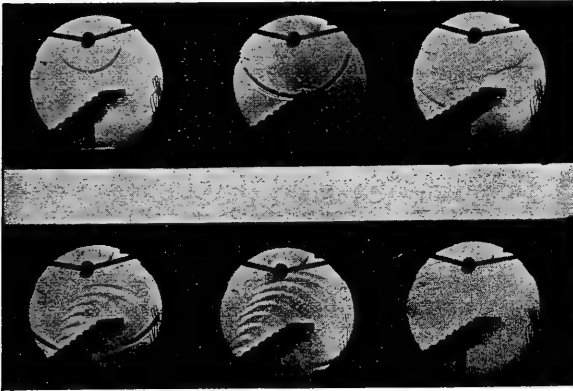

Having been unable to so control the time interval between the two sparks that a progressive series could be taken, I adopted the simpler method of making a large number of geometrical constructions, and then photographing them on a kinoscope film.

As a very large number of drawings (100 or so) must be made if the result is to be at all satisfactory, a method is desirable that will reduce the labour to a minimum. I may be permitted to give, as an instance, the method that I devised for building the series illustrating the reflexion of a plane wave in a spherical mirror. The construction is shown in the figure (p. 154).

ABC is the mirror, AOC the plane wave. Around points on ABC as centres describe circles tangent to the wave. These circles will be enveloped by another surface, ADE, below the mirror (the orthogonal surface). If we erect normals on this surface, we have the reflected rays, and if we measure off equal distances on the normals, we have the reflected wave-front. By drawing the orthogonal surface we avoid the complication of having to measure off the distances around a corner. The orthogonal surface is an epicycloid formed by the rolling of a circle of a diameter equal to the radius of curvature of the mirror on the mirror's

About a hundred pictures are prepared for each series, and the pictures then photographed separately on the film, which, when run through Mr. Paul's animatograph, will give us a very vivid representation of the motion of the wave-front.

The series illustrating reflexion inside of a complete sphere was the most difficult to prepare, as several reflexions have to be considered. It has been completed for three reflexions, and Mr. Max Mason, of Madison, to whom I am greatly indebted for his patient work in assisting me, is going on with the series. As will be seen, the wave has already become quite complicated, and it will be interesting to see what further changes result after three or four more reflexions. I am also under obligations to Prof. A. B. Porter, of Chicago, who prepared the set of drawings illustrating the passage of a wave out from the principal focus of a hemispherical mirror.

A number of points taken at intervals along the film are here reproduced, and give a fair idea of the transformations. Fig. 9 shows the plane wave entering the hemispherical

Fig. 9.

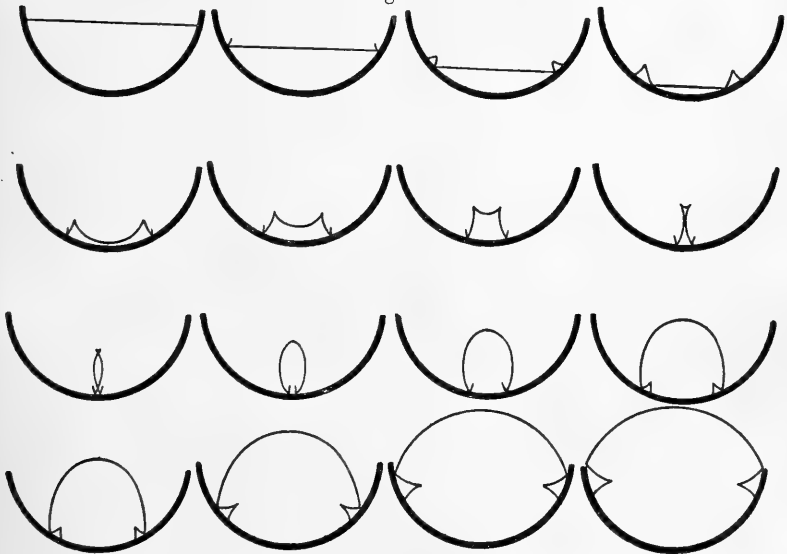

mirror, while in fig. 10 we have a spherical wave starting on the principal focus of a similar reflecting surface (compare fig. 9 with fig. 2, and fig. 10 with fig. 4). Fig. 11 shows the evolutions of the wave shut upon the complete spherical

mirror, and shows the development of the complicated photographed forms shown in fig. 6.

Fig. 10.

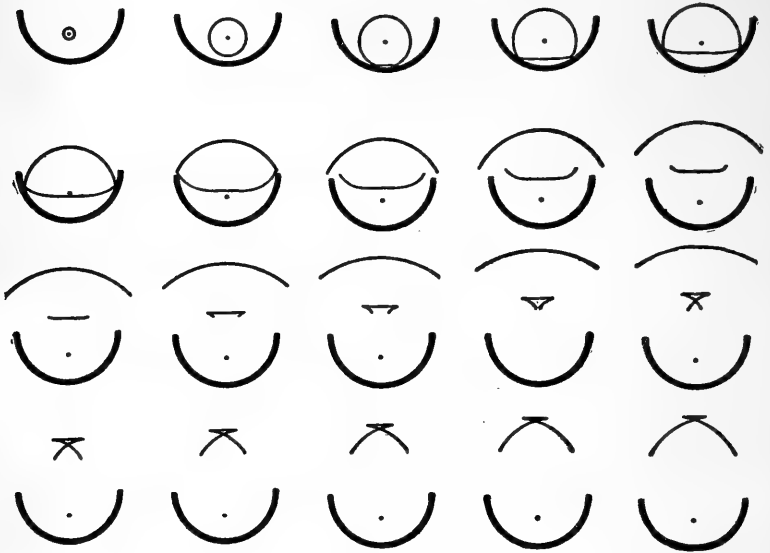
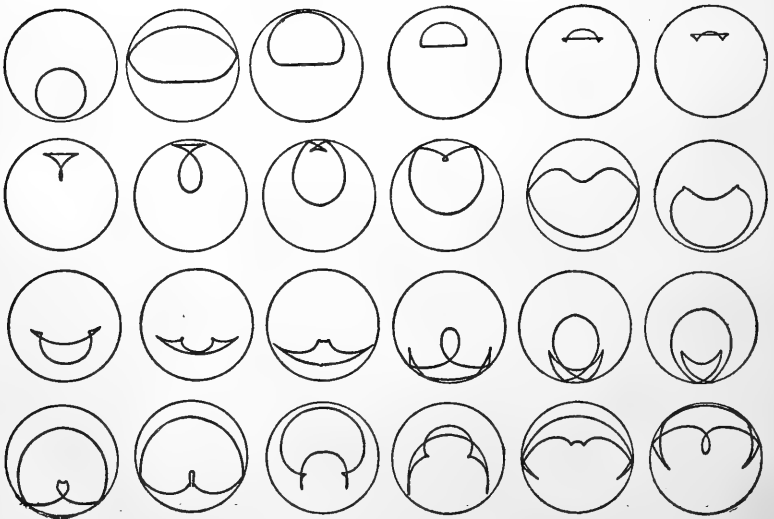

Fig. 11.



X. *On the Criterion that a given System of Deviations from the Probable in the Case of a Correlated System of Variables is such that it can be reasonably supposed to have arisen from Random Sampling.* By KARL PEARSON, F.R.S., University College, London*.

THE object of this paper is to investigate a criterion of the probability on any theory of an observed system of errors, and to apply it to the determination of goodness of fit in the case of frequency curves.

(1) *Preliminary Proposition.* Let $x_1, x_2 \dots x_n$ be a system of deviations from the means of n variables with standard deviations $\sigma_1, \sigma_2 \dots \sigma_n$ and with correlations $r_{12}, r_{13}, r_{23} \dots r_{n-1, n}$.

Then the frequency surface is given by

$$Z = Z_0 e^{-\frac{1}{2} \left\{ S_1 \left(\frac{R_{pp}}{R} \frac{x_p^2}{\sigma_p^2} \right) + 2S_2 \left(\frac{R_{pq}}{R} \frac{x_p x_q}{\sigma_p \sigma_q} \right) \right\}} \dots \dots \dots (i.)$$

where R is the determinant

$$\begin{vmatrix} 1 & r_{12} & r_{13} \dots r_{1n} \\ r_{21} & 1 & r_{23} \dots r_{2n} \\ r_{31} & r_{32} & 1 \dots r_{3n} \\ \dots & \dots & \dots & \dots \\ \dots & \dots & \dots & \dots \\ r_{n1} & r_{n2} & r_{n3} \dots 1 \end{vmatrix}$$

and R_{pp}, R_{pq} the minors obtained by striking out the p th row and p th column, and the p th row and q th column. S_1 is the sum for every value of p , and S_2 for every pair of values of p and q .

Now let

$$\chi^2 = S_1 \left(\frac{R_{pp}}{R} \frac{x_p^2}{\sigma_p^2} \right) + 2S_2 \left(\frac{R_{pq}}{R} \frac{x_p x_q}{\sigma_p \sigma_q} \right) \dots \dots \dots (ii.)$$

Then : $\chi^2 = \text{constant}$, is the equation to a generalized "ellipsoid," all over the surface of which the frequency of the system of errors or deviations $x_1, x_2 \dots x_n$ is constant. The values which χ must be given to cover the whole of space are from 0 to ∞ . Now suppose the "ellipsoid" referred to its principal axes, and then by squeezing reduced to a sphere, $X_1, X_2, \dots X$ being now the coordinates; then the chances of a system of errors with as great or greater frequency than

* Communicated by the Author.

that denoted by χ is given by

$$P = \frac{\left[\iiint \dots e^{-\frac{1}{2}\chi^2} dX_1 dX_2 \dots dX_n \right]_{\chi}^{\infty}}{\left[\iiint \dots e^{-\frac{1}{2}\chi^2} dX_1 dX_2 \dots dX_n \right]_0^{\infty}},$$

the numerator being an n -fold integral from the ellipsoid χ to the ellipsoid ∞ , and the denominator an n -fold integral from the ellipsoid 0 to the ellipsoid ∞ . A common constant factor divides out. Now suppose a transformation of coordinates to generalized polar coordinates, in which χ may be treated as the ray, then the numerator and denominator will have common integral factors really representing the generalized "solid angles" and having identical limits. Thus we shall reduce our result to

$$P = \frac{\int_{\chi}^{\infty} e^{-\frac{1}{2}\chi^2} \chi^{n-1} d\chi}{\int_0^{\infty} e^{-\frac{1}{2}\chi^2} \chi^{n-1} d\chi} \dots \dots \dots \text{(iii.)}$$

This is the measure of the probability of a complex system of n errors occurring with a frequency as great or greater than that of the observed system.

(2) So soon as we know the observed deviations and the probable errors (or σ 's) and correlations of errors in any case we can find χ from (ii.), and then an evaluation of (iii.) gives us what appears to be a fairly reasonable criterion of the probability of such an error occurring on a random selection being made.

For the special purpose we have in view, let us evaluate the numerator of P by integrating by parts; we find

$$\begin{aligned} \int_{\chi}^{\infty} e^{-\frac{1}{2}\chi^2} \chi^{n-1} d\chi &= \left[\chi^{n-2} + (n-2)\chi^{n-4} + (n-2)(n-4)\chi^{n-6} \right. \\ &\quad \left. + \dots + (n-2)(n-4)(n-6) \dots (n-2r-2)\chi^{n-2r} \right] e^{-\frac{1}{2}\chi^2} \\ &\quad + (n-2)(n-4)(n-6) \dots (n-2r) \int_{\chi}^{\infty} e^{-\frac{1}{2}\chi^2} \chi^{n-2r-1} d\chi \\ &= (n-2)(n-4)(n-6) \dots (n-2r) \left[\int_{\chi}^{\infty} e^{-\frac{1}{2}\chi^2} \chi^{n-2r-1} d\chi \right. \\ &\quad \left. + e^{-\frac{1}{2}\chi^2} \left\{ \frac{\chi^{n-2r}}{n-2r} + \frac{\chi^{n-2r+2}}{(n-2r)(n-2r+2)} + \frac{\chi^{n-2r+4}}{(n-2r)(n-2r+2)(n-2r+4)} \right. \right. \\ &\quad \left. \left. \dots + \frac{\chi^{n-2}}{(n-2r)(n-2r+2) \dots (n-2)} \right\} \right]. \end{aligned}$$

Further,

$$\int_0^\infty e^{-\frac{1}{2}\chi^2} \chi^{n-1} d\chi = (n-2)(n-4)(n-6) \dots (n-2r) \int_0^\infty e^{-\frac{1}{2}\chi^2} \chi^{n-2r-1} d\chi.$$

Now n will either be even or odd, or if n be indefinitely great we may take it practically either.

Case (i.) n odd. Take $r = \frac{n-1}{2}$. Hence

$$P = \frac{\int_0^\infty e^{-\frac{1}{2}\chi^2} d\chi + e^{-\frac{1}{2}\chi^2} \left\{ \frac{\chi}{1} + \frac{\chi^3}{1.3} + \frac{\chi^5}{1.3.5} + \dots + \frac{\chi^{n-2}}{1.3.5 \dots n-2} \right\}}{\int_0^\infty e^{-\frac{1}{2}\chi^2} d\chi} \dots \dots \dots \text{(iv.)}$$

But

$$\int_0^\infty e^{-\frac{1}{2}\chi^2} d\chi = \sqrt{\frac{\pi}{2}}.$$

Thus

$$P = \sqrt{\frac{2}{\pi}} \int_0^\infty e^{-\frac{1}{2}\chi^2} d\chi + \sqrt{\frac{2}{\pi}} e^{-\frac{1}{2}\chi^2} \left(\frac{\chi}{1} + \frac{\chi^3}{1.3} + \frac{\chi^5}{1.3.5} + \dots + \frac{\chi^{n-2}}{1.3.5 \dots n-2} \right). \text{(v.)}$$

As soon as χ is known this can be at once evaluated.

Case (ii.) n even. Take $r = \frac{1}{2}n - 1$. Hence

$$P = \frac{\int_0^\infty e^{-\frac{1}{2}\chi^2} \chi d\chi + e^{-\frac{1}{2}\chi^2} \left\{ \frac{\chi^2}{2} + \frac{\chi^4}{2.4} + \frac{\chi^6}{2.4.6} + \dots + \frac{\chi^{n-2}}{2.4.6 \dots n-2} \right\}}{\int_0^\infty e^{-\frac{1}{2}\chi^2} \chi d\chi} = e^{-\frac{1}{2}\chi^2} \left(1 + \frac{\chi^2}{2} + \frac{\chi^4}{2.4} + \frac{\chi^6}{2.4.6} + \dots + \frac{\chi^{n-2}}{2.4.6 \dots n-2} \right). \text{(vi.)}$$

The series (v.) and (vi.) both admit of fairly easy calculation, and give sensibly the same results if n be even moderately large. If we put $P = \frac{1}{2}$ in (v.) and (vi.) we have equations to determine $\chi = \chi_0$, the value giving the "probability ellipsoid." This ellipsoid has already been considered by Bertrand for $n=2$ (probability ellipse) and Czuber for $n=3$. The table which concludes this paper gives the values of P for a series of values of χ^2 in a slightly different case. We can, however, adopt it for general purposes, when we only want a rough approximation to the probability or improbability of a given system of deviations. Suppose we

have n correlated variables and we desire to ascertain whether an outlying observed set is really anomalous. Then we calculate χ^2 from (ii.); next we take $n' = n + 1$ to enter our table, *i. e.* if we have 7 correlated quantities we should look in the column marked 8. The row χ^2 and the column $n + 1$ will give the value of P , the probability of a system of deviations as great or greater than the outlier in question. For many practical purposes, the rough interpolation which this table affords will enable us to ascertain the general order of probability or improbability of the observed result, and this is usually what we want.

If n be very large, we have for the series in (v.) the value $e^{\frac{1}{2}\chi^2} \int_0^{\chi} e^{-\frac{1}{2}x^2} d\chi^*$, and accordingly

$$P = \sqrt{\frac{2}{\pi}} \int_0^{\infty} e^{-\frac{1}{2}x^2} d\chi = 1.$$

Again, the series in (vi.) for n very large becomes $e^{\frac{1}{2}\chi^2}$, and thus again $P = 1$. These results show that if we have only an indefinite number of groups, each of indefinitely small range, it is practically certain that a system of errors as large or larger than that defined by any value of χ will appear.

Thus, if we take a very great number of groups our test becomes illusory. We must confine our attention in calculating P to a finite number of groups, and this is undoubtedly what happens in actual statistics. n will rarely exceed 30, often not be greater than 12.

(3) Now let us apply the above results to the problem of the fit of an observed to a theoretical frequency distribution. Let there be an $(n + 1)$ -fold grouping, and let the observed frequencies of the groups be

$$m'_1, m'_2, m'_3 \dots m'_n, m'_{n+1},$$

and the theoretical frequencies supposed known *a priori* be

$$m_1, m_2, m_3 \dots m_n, m_{n+1};$$

then $S(m) = S(m') = N = \text{total frequency}$.

Further, if $e = m' - m$ give the error, we have

$$e_1 + e_2 + e_3 + \dots + e_{n+1} = 0.$$

Hence only n of the $n + 1$ errors are variables; the $n + 1$ th is

* Write the series as F , then we easily find $dF/d\chi = 1 + \chi F$, whence by integration the above result follows. Geometrically, $P = 1$ means that if n be indefinitely large, the n th moment of the tail of the normal curve is equal to the n th moment of the whole curve, however much or however little we cut off as "tail."

determined when the first n are known, and in using formula (ii.) we treat only of n variables. Now the standard deviation for the random variation of e_p is

$$\sigma_p = \sqrt{N \left(1 - \frac{m_p}{N}\right) \frac{m_p}{N}}, \quad \dots \quad (\text{vii.})$$

and if r_{pq} be the correlation of random error e_p and e_q ,

$$\sigma_p \sigma_q r_{pq} = -\frac{m_p m_q}{N} \dots \dots \dots (\text{viii.})$$

Now let us write $\frac{m_q}{N} = \sin^2 \beta_q$, where β_q is an auxiliary angle easily found. Then we have

$$\sigma_q = \sqrt{N} \sin \beta_q \cos \beta_q, \quad \dots \dots \dots (\text{ix.})$$

$$r_{pq} = -\tan \beta_q \tan \beta_p. \quad \dots \dots \dots (\text{x.})$$

We have from the value of R in § 1

$$R = \begin{vmatrix} 1 & -\tan \beta_2 \tan \beta_1 & -\tan \beta_3 \tan \beta_1 \dots -\tan \beta_n \tan \beta_1 \\ -\tan \beta_1 \tan \beta_2 & 1 & -\tan \beta_3 \tan \beta_2 \dots -\tan \beta_n \tan \beta_2 \\ -\tan \beta_1 \tan \beta_3 & -\tan \beta_2 \tan \beta_3 & 1 & \dots -\tan \beta_n \tan \beta_3 \\ \dots & \dots & \dots & \dots \\ \dots & \dots & \dots & \dots \\ \dots & \dots & \dots & \dots \\ -\tan \beta_1 \tan \beta_n & -\tan \beta_2 \tan \beta_n & -\tan \beta_3 \tan \beta_n & 1 \end{vmatrix}$$

$$= (-1)^n \tan^2 \beta_1 \tan^2 \beta_2 \tan^2 \beta_3 \dots \tan^2 \beta_n \times$$

$$\begin{vmatrix} -\cot^2 \beta_1 & 1 & 1 & \dots & 1 \\ 1 & -\cot^2 \beta_2 & 1 & \dots & 1 \\ 1 & 1 & -\cot^2 \beta_3 & \dots & 1 \\ \dots & \dots & \dots & \dots & \dots \\ \dots & \dots & \dots & \dots & \dots \\ 1 & 1 & 1 & \dots & -\cot^2 \beta_n \end{vmatrix}$$

$$= \tan^2 \beta_1 \tan^2 \beta_2 \tan^2 \beta_3 \dots \tan^2 \beta_n \times J, \text{ say.}$$

Similarly,

$$R_{11} = (-1)^{n-1} \tan^2 \beta_2 \tan^2 \beta_3 \dots \tan^2 \beta_n \times J_{11},$$

$$R_{12} = (-1)^{n-1} \tan \beta_1 \tan \beta_2 \tan^2 \beta_3 \dots \tan^2 \beta_n \times J_{12}.$$

Hence the problem reduces to the evaluation of the determinant J and its minors.

If we write

$$\eta_q = \cot^2 \beta_q = \frac{N}{m_q} - 1 \dots \dots \dots \text{(xi.)}$$

$$J = \begin{vmatrix} -\eta_1 & 1 & 1 & \dots & 1 \\ 1 & -\eta_2 & 1 & \dots & 1 \\ 1 & 1 & -\eta_3 & \dots & 1 \\ \dots & \dots & \dots & \dots & \dots \\ 1 & 1 & 1 & \dots & -\eta_n \end{vmatrix}$$

Clearly,

$$J_{12} = - \begin{vmatrix} 1 & 1 & 1 & \dots & 1 \\ 1 & -\eta_3 & 1 & \dots & 1 \\ 1 & 1 & -\eta_4 & \dots & 1 \\ \dots & \dots & \dots & \dots & \dots \\ 1 & 1 & 1 & \dots & -\eta_n \end{vmatrix}$$

$$= (-1)^{n-1} (\eta_3 + 1) (\eta_4 + 1) \dots (\eta_n + 1).$$

Generally, if $\lambda = (\eta_1 + 1)(\eta_2 + 1)(\eta_3 + 1) \dots (\eta_n + 1)$,

$$J_{pq} = (-1)^{n-1} \frac{\lambda}{(\eta_p + 1)(\eta_q + 1)} \dots \dots \text{(xii.)}$$

But $J_{11} - \eta_2 J_{12} + J_{13} + J_{14} + \dots + J_{1n} = 0.$

Hence $J_{11} = (1 + \eta_2)J_{12} - J_{13} - J_{14} - \dots - J_{1n}$

$$= \frac{(-1)^{n-1} \lambda}{1 + \eta_1} \left(1 - \frac{1}{1 + \eta_2} - \frac{1}{1 + \eta_3} - \frac{1}{1 + \eta_4} \dots - \frac{1}{1 + \eta_n} \right).$$

Whence, comparing J with J_{11} , it is clear that :

$$J = (-1)^n \lambda \left(1 - \frac{1}{1 + \eta_1} - \frac{1}{1 + \eta_2} - \frac{1}{1 + \eta_3} - \frac{1}{1 + \eta_4} \dots - \frac{1}{1 + \eta_n} \right).$$

Now

$$S \left(\frac{1}{1 + \eta} \right) = S \left(\frac{m}{N} \right), \text{ by (xi.)} = \frac{N - m_{n+1}}{N} = 1 - \frac{m_{n+1}}{N}.$$

Thus :

$$J = (-1)^n \lambda \frac{m_{n+1}}{N}.$$

Similarly :

$$J_{pp} = (-1)^{n-1} \frac{\lambda}{1 + \eta_p} \left(\frac{m_p}{N} + \frac{m_{n+1}}{N} \right).$$

Thus :

$$\frac{R_{pp}}{R} = - \frac{J_{pp}}{J} \cot^2 \beta_p = \cot^2 \beta_p \frac{m_p}{N} \left(1 + \frac{m_p}{m_{n+1}} \right);$$

or from (vii.)

$$\frac{R_{pp}}{R} \frac{1}{\sigma_p^2} = \frac{1}{m_p} + \frac{1}{m_{n+1}} \dots \dots \dots \text{(xiii.)}$$

Again :

$$\frac{R_{pq}}{R} = - \cot \beta_p \cot \beta_q \frac{J_{pq}}{J} = \cot \beta_p \cot \beta_q \frac{m_p m_q}{N m_{n+1}}.$$

and :

$$\frac{R_{pq}}{R} \frac{1}{\sigma_p \sigma_q} = \frac{1}{m_{n+1}} \dots \dots \dots \text{(xiv.)}$$

Thus by (ii.) :

$$\begin{aligned} \chi^2 &= S_1 \left\{ \left(\frac{1}{m_p} + \frac{1}{m_{n+1}} \right) e_p^2 \right\} + 2S_2 \left\{ \frac{1}{m_{n+1}} e_p e_q \right\} \\ &= S_1 \left(\frac{e_p^2}{m_p} \right) + \frac{1}{m_{n+1}} \left\{ S_1(e_p) \right\}^2. \end{aligned}$$

But

$$S_1(e_p) = - e_{n+1},$$

hence :

$$\chi^2 = S \left(\frac{e^2}{m} \right), \dots \dots \dots \text{(xv.)}$$

where the summation is now to extend to all $(n+1)$ errors, and not merely to the first n .

(4). This result is of very great simplicity, and very easily applicable. The quantity

$$\chi = \sqrt{S \left(\frac{e^2}{m} \right)}$$

is a measure of the goodness of fit, and the stages of our

investigation are pretty clear. They are:—

- (i.) Find χ from Equation (xv.):
- (ii.) If the number of errors, $n' = n + 1$, be odd, find the improbability of the system observed from

$$P = e^{-\frac{1}{2}\chi^2} \left(1 + \frac{\chi^2}{2} + \frac{\chi^4}{2 \cdot 4} + \frac{\chi^6}{2 \cdot 4 \cdot 6} + \dots + \frac{\chi^{n'-3}}{2 \cdot 4 \cdot 6 \dots n'-3} \right).$$

If the number of errors, $n' = n + 1$, be even, find the probability of the system observed from

$$P = \sqrt{\frac{2}{\pi}} \int_{\chi}^{\infty} e^{-\frac{1}{2}\chi^2} d\chi + \sqrt{\frac{2}{\pi}} e^{-\frac{1}{2}\chi^2} \left(\frac{\chi^3}{1 \cdot 3} + \frac{\chi^5}{1 \cdot 3 \cdot 5} + \dots + \frac{\chi^{n-3}}{1 \cdot 3 \cdot 5 \dots n-3} \right).$$

- (iii.) If n be less than 13, then the Table at the end of this paper will often enable us to determine the general probability or improbability of the observed system without using these values for P at all.

(5). Hitherto we have been considering cases in which the theoretical probability is known *à priori*. But in a great many cases this is not the fact; the theoretical distribution has to be judged from the sample itself. The question we wish to determine is whether the sample may be reasonably considered to represent a random system of deviations from the theoretical frequency distribution of the general population, but this distribution has to be inferred from the sample itself. Let us look at this somewhat more closely. If we have a fairly numerous series, and assume it to be really a random sample, then the theoretical number m for the whole population falling into any group and the theoretical number m_s as deduced from the data for the sample will only differ by terms of the order of the probable errors of the constants of the sample, and these probable errors will be small, as the sample is supposed to be fairly large. We may accordingly take:

$$m = m_s + \mu,$$

where the ratio of μ to m_s will, as a rule, be small. It is only at the "tails" that μ/m_s may become more appreciable, but here the errors or deviations will be few or small*.

* A theoretical probability curve without limited range will never at the extreme tails exactly fit observation. The difficulty is obvious where the observations go by units and the theory by fractions. We ought to take our final theoretical groups to cover as much of the tail area as amounts to at least a unit of frequency in such cases.

Now let χ_s be the value found for the sample, and χ the value required marking the system of deviations of the observed quantities from a group-system of the same number *accurately* representing the general population.

Then :

$$\begin{aligned} \chi^2 &= S \left\{ \frac{(m' - m)^2}{m} \right\} = S \left\{ \frac{m' - m_s - \mu}{m_s + \mu} \right\}^2 \\ &= S \left\{ \frac{(m' - m_s)^2}{m_s} \right\} - S \left\{ \frac{\mu(m'^2 - m_s^2)}{m_s} \right\} + S \left\{ \left(\frac{\mu}{m_s} \right)^2 \frac{m'^2}{m_s} \right\}, \end{aligned}$$

if we neglect terms of the order $(\mu/m_s)^3$.

Hence :

$$\chi^2 - \chi_s^2 = -S \left\{ \frac{\mu}{m_s} \frac{m'^2 - m_s^2}{m_s} \right\} + S \left\{ \left(\frac{\mu}{m_s} \right)^2 \frac{m'^2}{m_s} \right\}.$$

Now χ_s must, I take it, be less than χ , for otherwise the general population distribution or curve would give a better fit than the distribution or curve actually fitted to the sample. But we are supposed to fit a distribution or curve to the sample so as to get the "best" values of the constants. Hence the right-hand side of the above equation must be positive. If the first term be negative then it must be less than the second, or the difference of χ and χ_s is of the order, not of the first but of the *second* power of quantities depending on the probable errors of the sample. On the other hand, if the first term be positive, it means that there is negative correlation between $\frac{\mu}{m}$ and $\frac{m'^2 - m_s^2}{m_s}$, or that when the observed frequency exceeds the theoretical distribution given by the sample ($m' > m_s$), then the general population would fall below the theoretical distribution given by the sample ($m < m_s$), and *vice versa*. In other words the general population and the observed population would always tend to fall on opposite sides of the sample theoretical distribution. Now this seems impossible; we should rather expect, when the observations exceeded the sample theoretical distribution, that the general population would have also excess, and *vice versa*. Accordingly, we should either expect the first term to be negative, or to be very small (or zero) if positive. In either case I think we may conclude that χ only differs from χ_s by terms of the order of the squares of the probable errors of the constants of the sample distribution. Now our argu-

ment as to goodness of fit will be based on the general order of magnitude of the probability P , and not on slight differences in its value. Hence, if we reject the series as a random variation from the frequency distribution determined from the sample, we must also reject it as a random variation from a theoretical frequency distribution differing by quantities of the order of the probable errors of the constants from the sample theoretical distribution. On the other hand, if we accept it as a random deviation from the sample theoretical distribution, we may accept it as a random variation from a system differing by quantities of the order of the probable errors of the constants from this distribution.

Thus I think we can conclude, when we are dealing with a sufficiently long series to give small probable errors to the constants of the series, that :—

(i.) If χ_s^2 be so small as to warrant us in speaking of the distribution as a random variation on the frequency distribution determined from itself, then we may also speak of it as a random sample from a general population whose theoretical distribution differs only by quantities of the order of the probable errors of the constants, from the distribution deduced from the observed sample.

(ii.) If χ_s^2 be so large as to make it impossible for us to regard the observed distribution as a sample from a general population following the law of distribution deduced from the sample itself, it will be impossible to consider it as a sample from any general population following a distribution differing only by quantities of the order of the probable errors of the sample distribution constants from that sample distribution.

In other words, if a curve is a good fit to a sample, to the same fineness of grouping it may be used to describe other samples from the same general population. If it is a bad fit, then this curve cannot serve to the same fineness of grouping to describe other samples from the same population.

We thus seem in a position to determine whether a given form of frequency curve will effectively describe the samples drawn from a given population to a certain degree of fineness of grouping.

If it serves to this degree, it will serve for all rougher groupings, *but it does not follow* that it will suffice for still finer groupings. Nor again does it appear to follow that if the number in the sample be largely increased the same curve will still be a good fit. Roughly the χ^2 's of two samples appear to vary for the same grouping as their total contents. Hence if a curve be a good fit for a large sample it will be good for a small one, but the converse is not true, and a larger

sample may show that our theoretical frequency gives only an approximate law for samples of a certain size. In practice we must attempt to obtain a good fitting frequency for such groupings as are customary or utile. To ascertain the ultimate law of distribution of a population for any groupings, however small, seems a counsel of perfection.

(6) *Frequency known or supposed known a priori.*

Illustration I.

The following data are due to Professor W. F. R. Weldon, F.R.S., and give the observed frequency of dice with 5 or 6 points when a cast of twelve dice was made 26,306 times :—

No. of Dice in Cast with 5 or 6 Points.	Observed Frequency, m' .	Theoretical Frequency, m .	Deviation, e .
0	185	203	— 18
1	1149	1217	— 68
2	3265	3345	— 80
3	5475	5576	— 101
4	6114	6273	— 159
5	5194	5018	+ 176
6	3067	2927	+ 140
7	1331	1254	+ 77
8	403	392	+ 11
9	105	87	+ 18
10	14	13	+ 1
11	4	1	+ 3
12	0	0	0
	26306	26306	

The results show a bias from the theoretical results, 5 and 6 points occurring more frequently than they should do. Are the deviations such as to forbid us to suppose the results due to random selection? Is there in apparently true dice a real bias towards those faces with the maximum number of points appearing uppermost?

We have :—

Group.	e^2 .	e^2/m .	Group.	e^2 .	e^2/m .
0	324	1.59606	7	5929	4.72807
1	4624	3.79951	8	121	0.30903
2	6400	1.91330	9	324	3.72414
3	10201	1.82945	10	1	0.07346
4	25281	4.03013	11	9	9.00000
5	30976	6.17298	12	0	.00000
6	19600	6.69628			
			Total...	...	43.87241

Hence $\chi^2 = 43.87241$ and $\chi = 6.623,625$.

As there are 13 groups we have to find P from the formula :

$$P = e^{-\frac{1}{2}\chi^2} \left(1 + \frac{\chi^2}{2} + \frac{\chi^4}{2 \cdot 4} + \frac{\chi^6}{2 \cdot 4 \cdot 6} + \frac{\chi^8}{2 \cdot 4 \cdot 6 \cdot 8} + \frac{\chi^{10}}{2 \cdot 4 \cdot 6 \cdot 8 \cdot 10} \right),$$

which leads us to

$$P = .000016,$$

or the odds are 62,499 to 1 against such a system of deviations on a random selection. With such odds it would be reasonable to conclude that dice exhibit bias towards the higher points.

Illustration II.

If we take the total number of fives and sixes thrown in the 26,306 casts of 12 dice, we find them to be 106,602 instead of the theoretical 105,224. Thus $\frac{106,602}{12 \times 26,306} = .3377$ nearly, instead of $\frac{1}{3}$.

Professor Weldon has suggested to me that we ought to take $26,306(.3377 + .6623)^{12}$ instead of the binomial $26,306(\frac{1}{3} + \frac{2}{3})^{12}$ to represent the theoretical distribution, the difference between .3377 and $\frac{1}{3}$ representing the bias of the dice. If this be done we find :

Group.	m' .	m .	e .	e^2/m .
0	185	187	- 2	.021,3904
1	1149	1146	+ 3	.007,8534
2	3265	3215	+ 50	.777,6050
3	5475	5465	+ 10	.018,2983
4	6114	6269	-155	3.991,8645
5	5194	5115	+ 79	1.220,1342
6	3067	3043	+ 24	.189,2869
7	1331	1330	+ 1	.000,7519
8	403	424	- 21	1.040,0948
9	105	96	+ 9	.841,8094
10	14	15	- 1	.666,6667
11	4	1	+ 3	9
12	0	0	0	0

Hence : $\chi^2 = 17.775,7555$.

This gives us by the first formula in (ii.) of art. 4 :

$$P = .1227 ;$$

or the odds are now only 8 to 1 against a system of deviations as improbable as or more improbable than this one. It may be said accordingly that the dice experiments of Professor Weldon are consistent with the chance of five or six points being thrown by a single die being .3377, but they are excessively

improbable, if the chance of all the faces is alike and equal to 1/6th.

Illustration III.

In the case of runs of colour in the throws of the roulette-ball at Monte Carlo, I have shown* that the odds are at least 1000 millions to one against such a fortnight of runs as occurred in July 1892 being a random result of a true roulette. I now give χ^2 for the data printed in the paper referred to, *i. e.*:

4274 Sets at Roulette.

Runs	1	2	3	4	5	6	7	8	9	10	11	12	Over 12
Actual ...	246	945	333	220	135	81	43	30	12	7	5	1	0
Theory ...	2137	1068	534	267	134	67	33	17	8	4	2	1	0

From this we find $\chi^2 = 172.43$, and the improbability of a series as bad as or worse than this is about $14.5/10^{30}$! From this it will be more than ever evident how little chance had to do with the results of the Monte Carlo roulette in July 1892.

(7) *Frequency of General Population not known a priori.*

Illustration IV.†

In my memoir on skew-variation (Phil. Trans. vol. clxxxvi. p. 401) I have fitted the statistics for the frequency of petals in 222 buttercups with the skew-curve

$$y = .211225x^{-.322}(7.3253 - x)^{3.142}.$$

The possible range is from 5 to 11 petals, and the frequencies are:—

No. of Petals...	5	6	7	8	9	10	11
Observation ...	133	55	23	7	2	2	0
Theory	136.9	48.5	22.6	9.6	3.4	0.8	0.2

These lead to $\chi^2 = 4.885,528$; whence we find for the probability of a system of deviations as much or more removed

* 'The Chances of Death,' vol. i.: The Scientific Aspect of Monte Carlo Roulette, p. 54.

† Illustrations IV. and V. were taken quite at random from my available data. Other fits with skew-curves may give much worse results, others much better, for anything I can as yet say to the contrary,

from the most probable

$$P = .5586.$$

In 56 cases out of a hundred such trials we should on a random selection get more improbable results than we have done. Thus we may consider the fit remarkably good.

Illustration V.

The following table gives the frequencies observed in a system recorded by Thiele in his *Forelaesinger over almindelig Iagttagelseslaere*, 1889, together with the results obtained by fitting a curve of my Type I. The rough values of the moments only were, however, used, and as well ordinates used measure areas:—

Groups.	Observed m' .	Curve m_1 .	e .	e^2 .	e^2/m .
1	0	.18	— .18	.0324	.18
2	3	.68	— 2.32	5.3824	7.9153
3	7	13.48	+ 6.48	41.9904	3.1150
4	35	45.19	+10.19	103.8361	2.2977
5	101	79.36	—21.64	468.2896	5.9008
6	89	96.10	+ 7.10	50.4100	.5245
7	94	90.90	— 3.10	9.6100	.1058
8	70	71.41	+ 1.41	1.9881	.0278
9	46	48.25	+ 2.25	5.0625	.1049
10	30	28.53	— 1.47	2.1609	.0757
11	15	14.94	— .06	.0036	.0002
12	4	6.96	+ 2.96	8.7616	1.2523
13	5	2.88	— 2.12	4.4944	1.5605
14	1	1.06	+ .06	.0036	.0035
15	0	.34	+ .34	.1156	.3400
16	0	.10	+ .10	.0092	.0960
17	0	.00	+ 0	0	0
Total ...	500	500.36*	+ .36	...	23.5000

Thus gives $\frac{1}{2}\chi^2 = 11.75 = \eta$, say.

Then

$$P = e^{-\eta} \left(1 + \frac{\eta}{1} + \frac{\eta^2}{2} + \frac{\eta^3}{3} + \frac{\eta^4}{4} + \frac{\eta^5}{5} + \frac{\eta^6}{6} + \frac{\eta^7}{7} \right).$$

Substituting and working out we find

$$P = .101 = .1, \text{ say.}$$

Or, in one out of every ten trials we should expect to differ from the frequencies given by the curve by a set of deviations as improbable or more improbable. Considering that we should get a better fit of our observed and calculated frequencies by (i.) reducing the moments, and (ii.) actually

* Due to taking ordinates for areas and fewer figures than were really required in the calculations.

calculating the areas of the curve instead of using its ordinates, I think we may consider it not very improbable that the observed frequencies are compatible with a random sampling from a population described by the skew-curve of Type I.

Illustration VI.

In the current text-books of the theory of errors it is customary to give various series of actual errors of observation, to compare them with theory by means of a table of distribution based on the normal curve, or graphically by means of a plotted frequency diagram, and on the basis of these comparisons to assert that an experimental foundation has been established for the normal law of errors. Now this procedure is of peculiar interest. The works referred to generally give elaborate analytical proofs that the normal law of errors is the law of nature—proofs in which there is often a difficulty (owing to the complexity of the analysis and the nature of the approximations made) in seeing exactly what assumptions have been really made. The authors usually feel uneasy about this process of deducing a law of nature from Taylor's Theorem and a few more or less ill-defined assumptions; and having deduced the normal curve of errors, they give as a rule some meagre data of how it fits actual observation. But the comparison of observation and theory in general amounts to a remark—based on no quantitative criterion—of how well theory and practice really do fit! Perhaps the greatest defaulter in this respect is the late Sir George Biddell Airy in his text-book on the 'Theory of Errors of Observation.' In an Appendix he gives what he terms a "Practical Verification of the Theoretical Law for the Frequency of Errors."

Now that Appendix really tells us *absolutely nothing* as to the goodness of fit of his 636 observations of the N.P.D. of Polaris to a normal curve. For, if we first take on faith what he says, namely, that positive and negative errors may be clubbed together, we still find that he has *thrice smoothed* his observation frequency distribution before he allows us to examine it. It is accordingly impossible to say whether it really does or does not represent a random set of deviations from a normal frequency curve. All we can deal with is the table he gives of observed and theoretical errors and his diagram of the two curves. These, of course, are not his proper data at all: it is impossible to estimate how far his three smoothings counterbalance or not his multiplication of errors by eight. But as I understand Sir George Airy, he would have considered such a system of errors as he gives on his p. 117 or in his diagram on p. 118 to be sufficiently represented by a normal curve. Now I have investigated his 37 groups of errors, observational

and theoretical. In order to avoid so many different groups, I have tabulated his groups in $\cdot 10^4$ units, and so reduced them to 21. From these 21 groups I have found χ^2 by the method of this paper. By this reduction of groups I have given Sir George Airy's curve even a better chance than it has, as it stands. Yet what do we find? Why,

$$\chi^2 = 36 \cdot 2872.$$

Or, using the approximate equation,

$$P = \cdot 01423.$$

That is to say, only in one occasion out of 71 repetitions of such a set of observations on Polaris could we have expected to find a system of errors deviating as widely as this set (or more widely than this set) from the normal distribution. Yet Sir George Airy takes a set of observations, the odds against which being a random variation from the normal distribution are 70 to 1, to prove to us that the normal distribution applies to errors of observation. Nay, further, he cites this very improbable result as an experimental confirmation of the whole theory! "It is evident," he writes, "that the formula represents with all practicable accuracy the observed Frequency of Errors, upon which all the applications of the Theory of Probabilities are founded: and the validity of every investigation in this Treatise is thereby established."

Such a passage demonstrates how healthy is the spirit of scepticism in all inquiries concerning the accordance of theory and nature.

Illustration VII.

It is desirable to illustrate such results a second time. Professor Merriman in his treatise on Least Squares* starts in the right manner, not with theory, but with actual experience, and then from his data deduces three axioms. From these axioms he obtains by analysis the normal curve as the theoretical result. But if these axioms be true, his data can only differ from the normal law of frequency by a system of deviations such as would reasonably arise if a random selection were made from material actually obeying the normal law. Now Professor Merriman puts in the place of honour 1000 shots fired at a line on a target in practice for the U.S. Government, the deviations being grouped according to the belts struck, the belts were drawn on the target of equal breadth and parallel to the line. The following table gives the distribution of hits and the theoretical frequency-

* 'A Textbook on the Method of Least Squares,' 1891, p. 14.

distribution calculated from tables of the area of the normal curve*.

Belt.	Observed Frequency.	Normal Distribution.	$e.$	$\frac{e^2}{m}.$
1	1	1	0	0
2	4	6	- 2	·667
3	10	27	-17	10·704
4	89	67	+22	7·224
5	190	162	+28	4·839
6	212	242	-30	3·719
7	204	240	-36	5·400
8	193	157	+36	8·255
9	79	70	+ 9	1·157
10	16	26	-10	3·846
11	2	2	0	0
	1000	1000	$\chi^2 = 45·811$	

Hence we deduce: $P = \cdot000,00155.$

In other words, if shots are distributed on a target according to the normal law, then such a distribution as that cited by Mr. Merriman could only be expected to occur, on an average, some 15 or 16 times in 10,000,000 trials. Now surely it is very unfortunate to cite such an illustration as the foundation of those axioms from which the normal curve must flow! For if the normal curve flows from the axioms, then the data ought to be a probable system of deviations from the normal curve. But this they certainly are not. Now it appears to me that, if the earlier writers on probability had not proceeded so entirely from the mathematical standpoint, but had endeavoured first to classify experience in deviations from the average, and then to obtain some measure of the actual goodness of fit provided by the normal curve, that curve would never have obtained its present position in the theory of errors. Even today there are those who regard it as a sort of fetish; and while admitting it to be at fault as a means of generally describing the distribution of variation of a quantity x from its mean, assert that there must be some unknown quantity z of which x is an unknown function, and that z really obeys the normal law! This might be reasonable if there were but few exceptions to this universal law of error; but the difficulty is to find even the few variables which obey it, and these few are not those usually cited as illustrations by the writers on the subject!

* I owe the work of this illustration to the kindness of Mr. W. R. Macdonell, M.A., LL.D.

Illustration VIII.

The reader may ask : Is it not possible to find material which obeys within probable limits the normal law ? I reply, yes ; but this law is not a universal law of nature. We must hunt for cases. Out of three series of personal equations, I could only find one which approximated to the normal law. I took 500 lengths and bisected them with my pencil at sight. Without entering at length into experiments, destined for publication on another occasion, I merely give the observed and normal distribution of my own errors in 20 groups.

Group.	Observation.	Theory.	Group.	Observation.	Theory.
1	1	2·3	11	53	57·0
2	3	3·4	12	50·5	47·1
3	11	6·9	13	28·5	34·0
4	14·5	13·1	14	27	22·7
5	21·5	22·2	15	13·5	13·5
6	30	33·6	16	7·5	7·0
7	47	47·5	17	0	3·5
8	51·5	57·8	18	1	1·6
9	72	63·2	19	0	·6
10	65·5	62·7	20	2	·3

Calculating χ^2 in the manner already sufficiently indicated in this paper, we find

$$\chi^2 = 22·0422.$$

We must now use the more complex integral formula for P, and we find

$$P = ·2817.$$

Or, in every three to four random selections, we should expect one with a system of deviations from the normal curve greater than that actually observed.

I think, then, we may conclude that my errors of judgment in bisecting straight lines may be fairly represented by a normal distribution. It is noteworthy, however, that I found other observers' errors in judgment of the same series of lines were distinctly skew.

(8) We can only conclude from the investigations here considered that the normal curve possesses no special fitness for describing errors or deviations such as arise either in observing practice or in nature. We want a more general theoretical frequency, and the fitness of any such to describe a given series can be investigated by aid of the criterion discussed in this paper. For the general appreciation of the probability of the occurrence of a system of deviations defined by χ^2 (or any greater value), the accompanying table has been calculated, which will serve to give that probability closely enough for many practical judgments, without the calculations required by using the formulæ of art. 4.

TABLE OF VALUES OF P FOR VALUES OF χ^2 and n' ; χ^2 from 1 to 70, n' from 3 to 20*.

	3.	4.	5.	6.	7.	8.	9.	10.	11.	12.	13.	14.	15.	16.	17.	18.	19.	20.
1	.606,531	.801,253	.909,796	.962,566	.985,612	.994,829	.998,249	.999,438	.999,828	.999,950	.999,986	.999,997	.999,999	1.	1.	1.	1.	1.
2	.367,879	.572,407	.735,759	.849,146	.919,699	.959,839	.981,012	.991,466	.996,340	.998,494	.999,406	.999,772	.999,917	.999,969	.999,990	.999,996	.999,999	.999,999
3	.223,130	.391,633	.557,825	.699,994	.808,847	.885,010	.934,357	.964,303	.981,424	.990,734	.995,544	.997,942	.999,074	.999,605	.999,830	.999,938	.999,972	.999,997
4	.135,335	.261,470	.406,006	.549,422	.676,676	.779,783	.857,123	.911,418	.947,347	.969,923	.983,436	.991,197	.995,466	.997,743	.998,903	.999,489	.999,763	.999,899
5	.082,085	.171,799	.287,298	.415,882	.543,813	.659,965	.757,576	.834,910	.891,178	.931,168	.957,979	.975,195	.985,813	.992,128	.995,754	.997,772	.998,860	.999,433
6	.049,787	.111,611	.189,148	.306,220	.423,190	.539,750	.647,232	.739,919	.815,263	.873,366	.916,082	.946,154	.966,491	.979,749	.988,095	.993,187	.996,197	.997,930
7	.030,197	.071,888	.135,888	.220,631	.320,847	.428,870	.536,632	.637,110	.725,544	.799,074	.857,613	.902,142	.934,711	.957,640	.973,260	.983,539	.990,125	.994,203
8	.018,316	.046,012	.091,578	.156,236	.238,103	.332,594	.433,470	.534,146	.628,837	.713,304	.785,131	.843,601	.889,327	.923,783	.948,867	.966,547	.978,637	.986,671
9	.011,109	.029,291	.061,099	.109,064	.173,578	.252,656	.342,296	.437,274	.532,104	.621,892	.702,931	.772,944	.831,051	.877,518	.913,414	.940,262	.950,743	.973,479
10	.006,738	.018,367	.040,428	.075,236	.124,652	.188,574	.265,026	.350,488	.440,493	.530,388	.615,960	.693,935	.762,183	.819,740	.866,628	.903,611	.931,906	.952,946
15	.000,553	.001,817	.004,701	.010,363	.020,256	.036,000	.059,145	.090,810	.132,061	.182,371	.241,436	.307,227	.378,154	.450,691	.524,638	.594,156	.661,967	.721,272
20	.000,045	.000,170	.000,499	.001,250	.002,769	.005,570	.010,336	.017,913	.029,253	.045,341	.067,086	.095,212	.130,141	.171,934	.220,220	.274,231	.332,819	.394,580
25	.000,004	.000,016	.000,050	.000,139	.000,341	.000,753	.001,554	.002,971	.005,345	.009,117	.014,822	.023,084	.034,566	.049,943	.069,824	.094,710	.124,915	.160,542
30	.000,000	.000,001	.000,005	.000,015	.000,039	.000,095	.000,211	.000,439	.000,857	.001,585	.002,792	.004,710	.007,632	.011,921	.018,002	.026,345	.037,446	.051,798
40	.000,000	.000,000	.000,000	.000,000	.000,000	.000,001	.000,003	.000,008	.000,017	.000,036	.000,072	.000,138	.000,255	.000,453	.000,778	.001,294	.002,087	.003,272
50	.000,000	.000,000	.000,000	.000,000	.000,000	.000,000	.000,000	.000,000	.000,000	.000,000,5	.000,001	.000,003	.000,006	.000,012	.000,023	.000,042	.000,075	.000,131
60	.000,000	.000,000	.000,000	.000,000	.000,000	.000,000	.000,000	.000,000	.000,000	.000,000	.000,000	.000,000	.000,000	.000,000	.000,000	.000,001	.000,002	.000,004
70	.000,000	.000,000	.000,000	.000,000	.000,000	.000,000	.000,000	.000,000	.000,000	.000,000	.000,000	.000,000	.000,000	.000,000	.000,000	.000,000	.000,000	.000,000

* I have to thank Miss Alice Lee, D.Sc., for help in the calculation of part of this table. The certainty, *i. e.* the 1 in columns 16 to 20, denotes, of course, something greater than .999,9995, *i. e.* unity to six figures.

XI. *Notices respecting New Books.*

Histoire des Mathématiques. Par JACQUES BOYER. Illustrée de fac-similés de manuscrits et de portraits. Paris : Georges Carré et C. Naud, 1900 : pp. xi + 256.

THERE are two ways of writing a history of mathematics. One, which appeals to the general reader, consists in giving copious biographical details of the men to whose genius the science owes its existence, and in referring to their actual contributions to the science in as brief and concise a manner as possible. The other is to assign the chief place to their scientific contributions, and treat their biographies as of secondary importance. Of course, the two methods may be combined, but it seems to us that, if the book is to be kept within moderate limits, the writer will prefer to adopt one or other of the two plans indicated. M. Boyer appears to have chosen the second; his book is one primarily addressed to the student, and not to the general reader. The treatment is highly compressed, and it is very seldom that the author gives us anything beyond the dates of birth and death and the merest skeleton outline of the careers of the men who have moulded the science: he prefers to reserve his space for an account of their scientific work, and to present that account in as elementary a manner as the nature of the subject will allow. An interesting and puzzling piece of information is contained in the first chapter of the book, where, in giving an account of the recently discovered Babylonian tablets (dating back to 2000 B.C.) containing tables of the squares of the natural numbers, the author points out that the method of notation employed undoubtedly suggests the use of a *sexagesimal* system! The illustrations—of which there are 26—add greatly to the interest of the book; they are all reproductions of old engravings. The book is beautifully printed, and we have not noticed any typographical errors, with the single exception of p. 108, where $4 [2] + 3 [1]$ should read $3 [2] + 4 [1]$. The book is thoroughly up to date, the last chapter containing a brief sketch of the most recent developments of the science. To anybody wishing to acquire some knowledge of the history of mathematics, the book may be safely recommended as containing the desired information in a very concise form. But we cannot help thinking that the book might have been rendered much more interesting by the introduction of some of those human touches which render Mr. W. W. R. Ball's 'Short History of Mathematics' such delightful reading.

Physikalisches Praktikum. Mit besonderer Berücksichtigung der physikalisch-chemischen Methoden. Von EILHARD WIEDEMANN und HERMANN EBERT. Braunschweig: F. Vieweg und Sohn, 1899: pp. xxx. + 574.

The fact that this book is now in its fourth edition may be taken as a sufficient guarantee of its general excellence. One of its special features is the attention given to measurements which are of importance in chemical investigations, such as the determination of vapour-densities, melting-points, boiling-points, heats of neutralization &c. The arrangement of the subject-matter is strictly methodical, the general plan followed consisting in prefacing each section by a brief yet lucid account of the principles involved, then describing the apparatus used, and finally giving directions for carrying out a number of measurements. Great credit is due to the publishers for the beautiful engravings illustrating the various forms of instruments and apparatus described in the book; it is not often that such a uniformly high standard of excellence is maintained in this respect.

In a few of its details, the book would appear to be capable of some degree of improvement. Thus, it is extremely doubtful whether the section dealing with the "proof" of Ohm's law is conducive to clearing up a student's ideas on this subject. A "proof" of the law which involves the use of an *electromagnetic voltmeter* can hardly be taken seriously. Again, we regret to notice that the authors appear to use the terms "electromotive-force" and "potential difference" indiscriminately; this pernicious habit is productive of not a little confusion in the mind of a student. In the section on photometry, the form of Lummer and Brodhun photometer described is not the latest type of this instrument, but is an early form, which has since undergone considerable modifications.

In spite, however, of a few defects such as those noticed, there are probably few books on the subject which contain so large a mass of up-to-date and reliable information in so small a compass, and so attractive a form. The student who conscientiously works through the book and carries out the experiments described in it, will have acquired a very sound knowledge of physical processes and measurements. The tables and formulæ given at the end of the book should prove extremely useful. The copious table of contents at the beginning and the index at the end of the book also deserve a word of praise.

The Kinetic Theory of Gases. By Dr. OSKAR EMIL MEYER, Translated from the second revised edition by ROBERT E. BAYNES. M. A. London: Longmans, Green, & Co. 1899: pp. xvi. + 472.

Until comparatively recently, the whole of the literature dealing with the subject of physics could be divided into two sections: works dealing with the elements of various branches of the science,

Phil. Mag. S. 5. Vol. 50. No. 302. July 1900. N

written in very simple language and pre-supposing an extremely moderate knowledge on the part of the reader; and highly advanced treatises, which could be read only by those who had previously undergone a severe training in the higher branches of mathematics, and which were quite beyond the reach of any reader with more modest attainments. Between these two classes of books there was a great gulf fixed, with only very few exceptions. No help was offered to the student who, having taken the first steps in the subject, and finding himself unable to attend more classes or seek the guidance of a competent teacher, desired by private study somewhat to enlarge the meagre store of knowledge which he already possessed. If he turned to the various books at his disposal, he found that they either did not teach him anything which he did not already know, or else that they gave him a fit of mental indigestion.

This somewhat discreditable state of affairs has, it is true, been largely remedied nowadays, and the gap which formerly existed is being rapidly filled. It is a most promising sign of the times that our leaders in physical science no longer scorn to produce books of a fairly "elementary" character: it is hardly possible to exaggerate the importance which works of this kind have in raising the general level of scientific knowledge, and in stimulating further inquiry.

It is, therefore, greatly to the credit of the accomplished author of the book before us that as far back as 1877 it had occurred to him that possibly a few people might like to know something about the kinetic theory of gases who did not share the profound knowledge of the brilliant mathematicians by whose efforts the theory had been largely built up. Accordingly he set to work, and succeeded in producing a book which is now passing through a second edition, and of which the work under review is an English translation by Mr. Baynes.

Although described as an "elementary treatise" on the subject, the book consists of 352 pages forming the elementary portion, with 120 additional pages of "mathematical appendices," intended for the more advanced reader. This plan of sifting out the mathematics and relegating them to an appendix seems—in the present case, at any rate—to present a distinct advantage: the attention of the reader being thereby directed to the physical aspect of the reasoning, and not being diverted by purely mathematical difficulties. In the brief space at our disposal, we can do little more than merely indicate the nature and scope of the contents of the book. It is divided into three parts. Part I. deals with molecular motion and its energy, and is subdivided into five chapters dealing with (1) the foundations of the kinetic theory; (2) the pressure of gases; (3) Maxwell's law of speed distribution; (4) ideal and actual gases; and (5) the relation of molecular to atomic energy. Part II. is concerned with the molecular free paths and the phenomena conditioned by them, and is subdivided into four chapters, dealing with (1) the molecular free paths; (2) the vis-

cosity of gases ; (3) diffusion and (4) conduction of heat. Part III., on the direct properties of molecules, consists of a single chapter—probably the most fascinating in the whole book.

For the benefit of those who wish to pursue their studies beyond the limits of the book, a wealth of references to original sources of information is given. English physicists will feel a debt of gratitude to Mr. Baynes for the trouble of translating the book—no easy task—and for the few notes which he has appended to it. It is, therefore, somewhat unwillingly that we close this notice by saying that in several instances we consider the translation somewhat too literal, with the result that the English rendering smacks too much of the German idiom.

XII. *Proceedings of Learned Societies.*

GEOLOGICAL SOCIETY.

[Continued from vol. xlix. p. 572.]

March 7th (*cont.*).—J. J. H. Teall, Esq., M.A., F.R.S., President, in the Chair.

The following communications were read :—

2. ‘The Rocks of the South-eastern Coast of Jersey.’ By John Parkinson, Esq., F.G.S.

In this paper the author has continued the study of the deep-seated rocks of Jersey begun in a communication presented to the Society last session entitled ‘On an Intrusion of Granite into Diabase at Sorel Point (Northern Jersey).’ A great resemblance exists between these rocks in the north and south of the island, and it is concluded that they represent parts of the same magma ; but in the south-east additional complications arise, owing to the intrusion of another rock before the invasion of the granite. For convenience of study the district under discussion is divided into two parts, an Eastern and a Western, separated the one from the other by the western termination of the Grève d’Azette. In the Eastern district the granite and the intrusive rock which preceded it are found ; in the Western a rather different rock invades the diabase. The latter is correlated with the aplite-intrusion of the northern coast.

Taking first the earlier intrusion found at Le Nez Point, it is shown that it consists of a rock more acid than a diorite, but on the whole more basic than the granite which followed it. Microscopical examination indicates that it was poor in ferro-magnesian minerals, and that quartz and orthoclase, though present, are not found in the proportion which characterizes the granite. This rock, the exact composition of which it is not easy to discover, has invaded the diabase, as well as a dioritic rock associated with it, streaking and veining them. Mixing took place as a result of such

intrusion, producing a composite rock characterized by elongated hornblendes which occasionally attain a considerable size. Mica is conspicuously absent.

The intrusion of the granite following this is next described. Here, as on the northern coast, local absorption of the older rock has taken place. The resemblance between the mixed rocks is commented upon, and a parallel drawn between the basic and acid rocks of Jersey and the eastern and northern coasts of Guernsey.

Passing to the Western district, the aplite of St. Elizabeth's Castle is described, together with the melting and absorption which have taken place as a consequence of this intrusion. Field-evidence indicates that this is later than any intrusion found in the Eastern district, though the difference in age is probably but slight: thus it bears out the results of work on the northern coast, where the intrusion of an aplite was found to have followed that of a porphyritic granite. Reasons are given in the body of the paper for believing that successive intrusions cannot be separated the one from the other by hard-and-fast lines. Finally, it is suggested that the various rocks considered are closely related, and indeed form parts of one magma, the successive injections of which became progressively more acid.

3. 'The Rocks of La Saline (Northern Jersey).' By John Parkinson, Esq., F.G.S.

The rocks of La Saline closely resemble those of Sorel Point, about a mile to the west. A coarse porphyritic granite is found in the upper part of the cliff which passes rapidly into an equally coarse but redder rock, approaching an aplite in composition. The latter occasionally contains mica in some quantity, and evidence is given for concluding that this mineral has been produced by the combination of the constituents of the augite of a dolerite, through which the acid magma forced its way, and the felspathic parts of the magma itself. This evidence is based (i) on the fact that in one part of the Bay a few outcrops of rock are found identical with others from Sorel Point, which have been clearly formed by the absorption of fragments of diabase (dolerite) by an acid magma; (ii) on the presence of fragment-like patches rich in mica in the aplite itself; (iii) by the irregular distribution of this mineral through the acid rock. A peculiar quartz-less rock is next described containing large orthoclases, plagioclase, and chlorite: it is concluded that the last-named mineral is derived from mica. With some hesitation the structure of this rock is explained by supposing that the intruding magma melted a mass of dolerite, completely dissolved the felspar, and produced mica in the manner indicated above; and that as freedom of movement was not greatly restricted, segregation of the basic elements followed, enclosing among them numerous porphyritic orthoclases. Some movement of the whole then appears to have taken place.

THE
LONDON, EDINBURGH, AND DUBLIN
PHILOSOPHICAL MAGAZINE
AND
JOURNAL OF SCIENCE.

[FIFTH SERIES.]

AUGUST 1900.

XIII. *On the Motion produced in an Infinite Elastic Solid by the Motion through the Space occupied by it of a body acting on it only by Attraction or Repulsion.* By Lord KELVIN*.

§ 1. **T**HE title of the present communication describes a pure problem of abstract mathematical dynamics, without indication of any idea of a physical application. For a merely mathematical journal it might be suitable, because the dynamical subject is certainly interesting both in itself and in its relation to waves and vibrations. My reason for occupying myself with it, and for offering it to the Royal Society of Edinburgh, is that it suggests a conceivable explanation of the greatest difficulty hitherto presented by the undulatory theory of light;—the motion of ponderable bodies through infinite space occupied by an elastic solid †.

§ 2. In consideration of the confessed object, and for brevity, I shall use the word atom to denote an ideal substance occupying a given portion of solid space, and acting on the ether within it and around it, according to the old-fashioned eighteenth century idea of attraction and repulsion. That is to say, every infinitesimal volume A of

* Communicated by the Author, having been read before the Royal Society of Edinburgh, July 16th, 1900.

† The so-called "electro-magnetic theory of light" does not cut away this foundation from the old undulatory theory of light. It adds to that primary theory an enormous province of transcendent interest and importance; it demands of us not merely an explanation of all the phenomena of light and radiant heat by transverse vibrations of an elastic solid called ether, but also the inclusion of electric currents, of the permanent magnetism of steel and lodestone, of magnetic force, and of electrostatic force, in a comprehensive ethereal dynamics.

the atom acts on every infinitesimal volume B of the ether with a force in the line PQ joining the centres of these two volumes, equal to

$$Af(P, PQ)\rho B \dots \dots \dots (1),$$

where ρ denotes the density of the ether at Q, and $f(P, PQ)$ denotes a quantity depending on the position of P and on the distance PQ. The whole force exerted by the atom on the portion ρB of the ether at Q, is the resultant of all the forces calculated according to (1), for all the infinitesimal portions A into which we imagine the whole volume of the atom to be divided.

§ 3. According to the doctrine of the potential in the well-known mathematical theory of attraction, we find rectangular components of this resultant as follows:—

$$\left. \begin{aligned} X &= \rho B \frac{d}{dx} \phi(x, y, z); & Y &= \rho B \frac{d}{dy} \phi(x, y, z); \\ Z &= \rho B \frac{d}{dz} \phi(x, y, z) \end{aligned} \right\} \dots (2),$$

where x, y, z denote co-ordinates of Q referred to lines fixed with reference to the atom, and ϕ denotes a function (which we call the potential at Q due to the atom) found by summation as follows:—

$$\phi = \iiint A \int_{PQ}^{\infty} dr f(P, r) \dots \dots \dots (3),$$

where $\iiint A$ denotes integration throughout the volume of the atom.

§ 4. The notation of (1) has been introduced to signify that no limitation as to admissible law of force is essential; but no generality, that seems to me at present practically desirable, is lost if we assume, henceforth, that it is the Newtonian law of the inverse square of the distance. This makes

$$f(P, PQ) = \frac{\alpha}{PQ^2} \dots \dots \dots (4),$$

and therefore

$$\int_{PQ}^{\infty} dr f(P, r) = \frac{\alpha}{PQ} \dots \dots \dots (5),$$

where α is a coefficient specifying for the point, P, of the atom, the intensity of its attractive quality for ether. Using

(5) in (3) we find

$$\phi = \iiint A \frac{\alpha}{PQ} \dots \dots \dots (6),$$

and the components of the resultant force are still expressed by (2). We may suppose α to be either positive or negative (positive for attraction and negative for repulsion); and in fact in our first and simplest illustration of the problem we suppose it to be positive in some parts and negative in other parts of the atom, in such quantities as to fulfil the condition

$$\iiint A\alpha = 0 \dots \dots \dots (7).$$

§ 5. As a first and very simple illustration, suppose the atom to be spherical, of radius unity, with concentric interior spherical surfaces of equal density. This gives, for the direction of the resultant force on any particle of the ether, whether inside or outside the spherical boundary of the atom, a line through the centre of the atom. The further assumption of (7) may now be expressed by

$$\int_0^1 dr r^2 \alpha = 0 \dots \dots \dots (8);$$

and this, as we are now supposing the forces between every particle of the atom and every particle of the ether to be subject to the Newtonian law, implies, that the resultant of its attractions and repulsions is zero for every particle of ether outside the boundary of the atom. To simplify the case to the utmost, we shall further suppose the distribution of positive and negative density of the atom, and the law of compressibility of the ether, to be such, that the average density of the ether within the atom is equal to the undisturbed density of the ether outside. Thus the attractions and repulsions of the atom in lines through its centre produce, at different distances from its centre, condensations and rarefactions of the ether, with no change of the total quantity of it within the boundary of the atom; and therefore produce no disturbance of the ether outside. To fix the ideas, and to illustrate the application of the suggested hypothesis to explain the refractivity of ordinary isotropic transparent bodies such as water or glass, I have chosen a definite particular case in which the distribution of the ether when at rest within the atom is expressed by the following formula, and partially shown in the accompanying diagram (p. 186), and tables of calculated numbers:—

$$r^3 = \frac{r'^3}{1 + K(1 - r')^2} \dots \dots \dots (9).$$

Here, r' denotes the undisturbed distance from the centre of the atom, of a particle of the ether which is at distance r when at rest under the influence of the attractive and repulsive forces. According to this notation $\frac{4\pi}{3}\delta(r^3)$ is the disturbed volume of a spherical shell of ether whose undisturbed radius is r' and thickness $\delta r'$ and volume $\frac{4\pi}{3}\delta(r'^3)$. Hence, if we denote the disturbed and undisturbed densities of the ether by ρ and unity respectively, we have

$$\rho\delta(r^3) = \delta(r'^3) \dots \dots \dots (10);$$

whence, by (9),

$$\rho = \frac{3[1 + K(1 - r')^2]^2}{3 + K(3 - r')(1 - r')} \dots \dots \dots (11).$$

This gives $1 + K$ for the density of the ether at the centre of the atom. In order that the disturbance may suffice for refractivities such as those of air, or other gases, or water, or glass, or other transparent liquids or isotropic solids, according to the dynamical theory explained in §(16) below, I find that K may for some cases be about equal to 100, and for others must be considerably greater. I have therefore taken $K = 100$, and calculated and drawn the accompanying tables and diagram accordingly.

TABLE I.

Col. 1.	Col. 2.	Col. 3.	Col. 3'.	Col. 4.	Col. 5.
r' .	$\frac{r'^3}{r^3} = 1 + K(1 - r')^2$.	r .	$r' - r$.	ρ .	$(\rho - 1)r^2$.
0.00	101.0	0.000	0.000	101.0	0.000
.05	91.25	.011	.039	88.1	.011
.10	82.0	.023	.077	75.3	.039
.20	65.0	.049	.151	55.8	.132
.30	50.0	.082	.218	39.1	.256
.40	37.0	.120	.280	25.8	.357
.50	26.0	.169	.331	15.8	.423
.60	17.0	.233	.367	8.76	.423
.70	10.0	.325	.375	4.17	.338
.80	5.0	.468	.332	1.60	.131
.85	3.25	.578	.272	0.90	-0.033
.90	2.00	.715	.185	0.50	-.256
.95	1.25	.865	.085	.35	-.486
.96	1.16	.897	.063	.36	-.515
.97	1.09	.928	.042	.39	-.525
.98	1.04	.957	.023	.46	-.495
.99	1.01	.982	.008	.61	-.376
1.00	1.00	1.000	.000	1.00	-.000

TABLE II.

Col. 1.	Col. 2.	Col. 3.	Col. 4.	Col. 5.
r .	r' .	$r-r'$.	ρ .	$(\rho-1)r^2$.
0·00	0·000	0·000	101·00	0·000
·02	·091	·071	78·5	·030
·04	·169	·129	64·4	·191
·06	·235	·175	49·6	·175
·08	·297	·217	39·5	·246
·10	·351	·251	31·8	·308
·20	·551	·351	11·8	·432
·30	·677	·377	5·00	·360
·40	·758	·358	2·46	·234
·50	·816	·316	1·34	·085
·60	·858	·258	0·82	—0·065
·70	·895	·195	0·53	—·231
·80	·929	·129	0·38	—·397
·90	·961	·061	0·36	—·518
1·00	1·000	·000	1·00	·000

§ 6. The diagram (fig. 1) helps us to understand the displacement of ether and the resulting distribution of density, within the atom. The circular arc marked 1·00 indicates a spherical portion of the boundary of the atom; the shorter of the circular arcs marked ·95, ·90, ·20, ·10 indicate spherical surfaces of undisturbed ether of radii equal to these numbers. The position of the spherical surfaces of the same portions of ether under the influence of the atom, are indicated by the arc marked 1·00, and the longer of the arcs marked ·95, ·90, . . . ·50, and the complete circles marked ·40, ·30, ·20, ·10. It may be remarked that the average density of the ether within any one of the disturbed spherical surfaces, is equal to the cube of the ratio of the undisturbed radius to the disturbed radius, and is shown numerically in column 2 of Table I. Thus, for example, looking at the table and diagram, we see that the cube of the radius of the short arc marked ·50 is 26 times the cube of the radius of the long arc marked ·50, and therefore the average density of the ether within the spherical surface corresponding to the latter is 26 times the density (unity) of the undisturbed ether within the spherical surface corresponding to the former. The densities shown in column 4 of each table are the densities of the ether at (not the average density of the ether within) the concentric spherical surfaces of radius r in the atom. Column 5 in each table shows $1/4\pi r^2 e$ of the excess (positive or negative) of the quantity of ether in a shell of radius r and infinitely small thickness e as disturbed by the atom above the quantity in a shell of the same dimensions of-

Fig. 1.

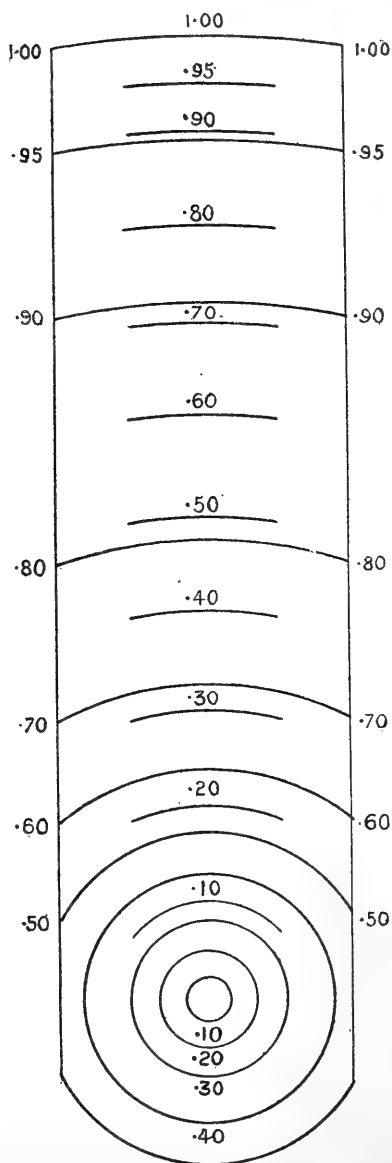

undisturbed ether. The formula of col. 2 makes $r=1$ when $r=1$, that is to say the total quantity of the disturbed ether within the radius of the atom is the same as that of undisturbed ether in a sphere of the same radius. Hence the sum of the quantities of ether calculated from col. 5 for consecutive values of r , with infinitely small differences from $r=0$ to $r=1$, must be zero. Without calculating for smaller differences of r than those shown in either of the tables, we find a close verification of this result by drawing, as in fig. 2,

Fig. 2.

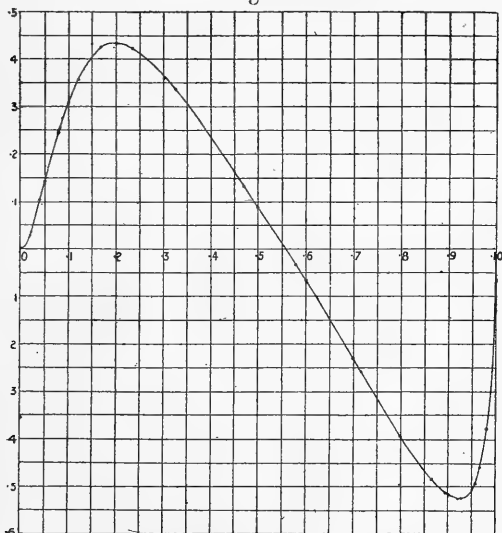

a curve to represent $(\rho-1)r^2$ through the points for which its value is given in one or other of the tables, and measuring the areas on the positive and negative sides of the line of abscissas. By drawing on paper (four times the scale of the annexed diagram), showing engraved squares of $\cdot 5$ inch and $\cdot 1$ inch, and counting the smallest squares and parts of squares in the two areas, I have verified that they are equal within less than 1 per cent. of either sum, which is as close as can be expected from the numerical approximations shown in the tables, and from the accuracy attained in the drawing.

§ 7. In Table I. (argument r') all the quantities are shown for chosen values of r' , and in Table II. for chosen values of r . The calculations for Table I. are purely algebraic, involving merely cube roots beyond elementary arithmetic. To calculate in terms of given values of r the results shown in Table II. involves the solution of a cubic equation. They

have been actually found by aid of a curve drawn from the numbers of col. 3 Table I., showing r in terms of r' . The numbers in col. 2 of Table II. showing, for chosen values of r , the corresponding values of r' , have been taken from the curve; and we may verify that they are approximately equal to the roots of the equation shown at the head of col. 2 of Table I., regarded as a cubic for r' with any given values of r and K .

Thus, for example, taking $r' = \cdot 929$ we calculate $r = \cdot 811$,
 „ $r' = \cdot 816$ „ $r = \cdot 498$,
 „ $r' = \cdot 677$ „ $r = \cdot 301$,
 „ $r' = \cdot 091$ „ $r = \cdot 0208$,

where we should have $r = \cdot 8, \cdot 5, \cdot 3$, and $\cdot 02$ respectively. These approximations are good enough for our present purpose.

§ 8. The diagram of fig. 2 is interesting, as showing how, with densities of ether varying through the wide range of from $\cdot 35$ to 101, the whole mass within the atom is distributed among the concentric spherical surfaces of equal density. We see by it, interpreted in conjunction with col. 4 of the tables, that from the centre to $\cdot 56$ of the radius the density falls from 101 to 1. For radii from $\cdot 56$ to 1, the values of $(\rho - 1)r^2$ decrease to a negative minimum of $\cdot 525$ at $r = \cdot 93$, and rise to zero at $r = 1$. The place of minimum density is of course inside the radius at which $(\rho - 1)r^2$ is a minimum; by cols. 4 and 3 of Table I., and cols. 4 and 1 of Table II., we see that the minimum density is about $\cdot 35$, and at distance approximately $\cdot 87$ from the centre.

§ 9. Let us suppose now our atom to be set in motion through space occupied by ether, and kept in motion with a uniform velocity v , which we shall first suppose to be infinitely small in comparison with the propagational velocity of equivoluminal* waves through pure ether undisturbed by any other substance than that of the atom. The velocity of the earth in its orbit round the sun being about $1/10,000$ of the velocity of light, is small enough to give results, kinematic and dynamic, in respect to the relative motion of ether and the atoms constituting the earth closely in agreement with this supposition. According to it, the position of every particle of the ether at any instant is the same as if the atom were at rest; and to find the motion produced in the ether by the motion of the atom, we have a purely kinematic problem of which an easy graphic solution is found by marking on a

* That is to say, waves of transverse vibration, being the only kind of wave in an isotropic solid in which every part of the solid keeps its volume unchanged during the motion. See *Phil. Mag.*, May, August, and October, 1899.

diagram the successive positions thus determined for any particle of the ether, according to the positions of the atom at successive times with short enough intervals between them, to show clearly the path and the varying velocity of the particle.

§ 10. Look, for example, at fig. 3, in which a semi-circumference of the atom at the middle instant of the time we are going to consider, is indicated by a semicircle $C_{20}AC_0$, with diameter C_0C_{20} equal to two units of length. Suppose the centre of the atom to move from right to left in the straight line C_0C_{20} with velocity $\cdot 1$, taking for unit of time the time of travelling $1/10$ of the radius. Thus, reckoning from the time when the centre is at C_0 , the times when it is at $C_2, C_5, C_{10}, C_{18}, C_{20}$ are 2, 5, 10, 18, 20. Let Q' be the undisturbed position of a particle of ether before time 2 when the atom reaches it, and after time 18 when the atom leaves it. This implies that $Q'C_2 = Q'C_{18} = 1$, and $C_2C_{10} = C_{10}C_{18} = \cdot 8$, and therefore $C_{10}Q' = \cdot 6$. The position of the particle of ether, which when undisturbed is at Q' , is found for any instant t of the disturbance as follows:—

Take $C_0C = t/10$; draw $Q'C$, and calling this r' find $r' - r$ by formula (9), or Table I. or II.: in $Q'C$ take $Q'Q = r' - r$. Q is the position at time t of the particle whose undisturbed position is Q' . The drawing shows the construction for $t = 2$, and $t = 5$, and $t = 18$. The positions at times 2, 3, 4, 5, 15, 16, 17, 18 are indicated by the dots marked 2, 3, 4, 5, 6, 7, 8, 9, 0, 1, 2, 3, 4, 5, 6, 7, 8 on the closed curve with a corner at Q' , which has been found by tracing a smooth curve through them. This curve, which, for brevity, we shall call the orbit of the particle, is clearly tangential to the lines $Q'C_2$ and $Q'C_{18}$. By looking to the formula (9), we see that the velocity of the particle is zero at the instants of leaving Q' and returning to it. Fig. 4 shows the particular orbit of fig. 3, and nine others drawn by the same method; in all ten orbits of ten particles whose undisturbed positions are in one line at right angles to the line of motion of the centre of the atom, and at distances 0, $\cdot 1, \cdot 2, \dots \cdot 9$ from it. All these particles are again in one straight line at time 10, being what we may call the time of mid-orbit of each particle. The numbers marked on the right-hand halves of the orbits are times from the zero of our reckoning; the numbers 1, 2, 3 . . . etc. on the left correspond to times 11, 12, 13 . . . of our reckoning as hitherto, or to times 1, 2, 3 . . . after mid-orbit passages. Lines drawn across the orbits through 1, 2, 3 . . . on the left, show simultaneous positions of the ten particles at times 1, 2, 3 after mid-orbit. The line drawn from 4 across seven of the curved orbits, shows for time 4 after mid-orbit,

simultaneous positions of eight particles, whose undisturbed distances are 0, .1,7. Remark that the orbit for the first of these ten particles is a straight line.

§ 11. We have thus in § 10 solved one of the two chief kinematic questions presented by our problem:—to find the orbit of a particle of ether as disturbed by the moving atom, relatively to the surrounding ether supposed fixed. The other question, to find the path traced through the atom supposed fixed while, through all space outside the atom, the ether is supposed to move uniformly in parallel lines, is easily solved, as follows:—Going back to fig. 3, suppose now that instead of, as in § 10, the atom moving from right to left with velocity .1 and the ether outside it at rest, the atom is at rest and the ether outside it is moving from left to right with velocity .1. Let '2, '3, '4, '5, '6, '7, '8, '9, 0, '1, '2, '3, '4, '5, '6, '7, '8 be the path of a particle of ether through the atom marked by seventeen points corresponding to the same numbers unaccented showing the orbit of the same particle of ether on the former supposition. On both suppositions, the position of the particle of ether at time 10 from our original era, (§ 10), is marked 0. For times 11, 12, 13, etc., the positions of the particle on the former supposition are marked 1, 2, 3, 4, 5, 6, 7, 8 on the left half of the orbit. The positions of the same particle on the present supposition are found by drawing from the points 1, 2, 3, . . . 7, 8 parallel lines to the right, 1 '1, 2 '2, 3 '3, . . . 7 '7, 8 '8, equal respectively to .1, .2, .3,7, .8 of the radius of the atom, being our unit of length. Thus we have the latter half of the passage of the particle through the atom; the first half is equal and similar on the left-hand side of the atom. Applying the same process to every one of the ten orbits shown in fig. 4 (p. 192), and to the nine orbits of particles whose undisturbed distances from the central line on the other side are .1, .2,9, we find the set of stream-lines shown in fig. 5 (p. 193). The dots on these lines show the positions of the particles at times 0, 1, 2, . . . 19, 20 of our original reckoning (§ 10). The numbers on the stream-line of the particle whose undisturbed distance from the central line is .6 are marked for comparison with fig. 3. The lines drawn across the stream-lines on the left-hand side of fig. 5 show simultaneous positions of rows of particles of ether which, when undisturbed, are in straight lines perpendicular to the direction of motion. The quadrilaterals thus formed within the left-hand semicircle show the figures to which the squares of ether, seen entering from the left-hand end of the diagram, become altered in passing through the atom. Thus we have completed the solution of our second chief kinematic question.

Fig. 4.

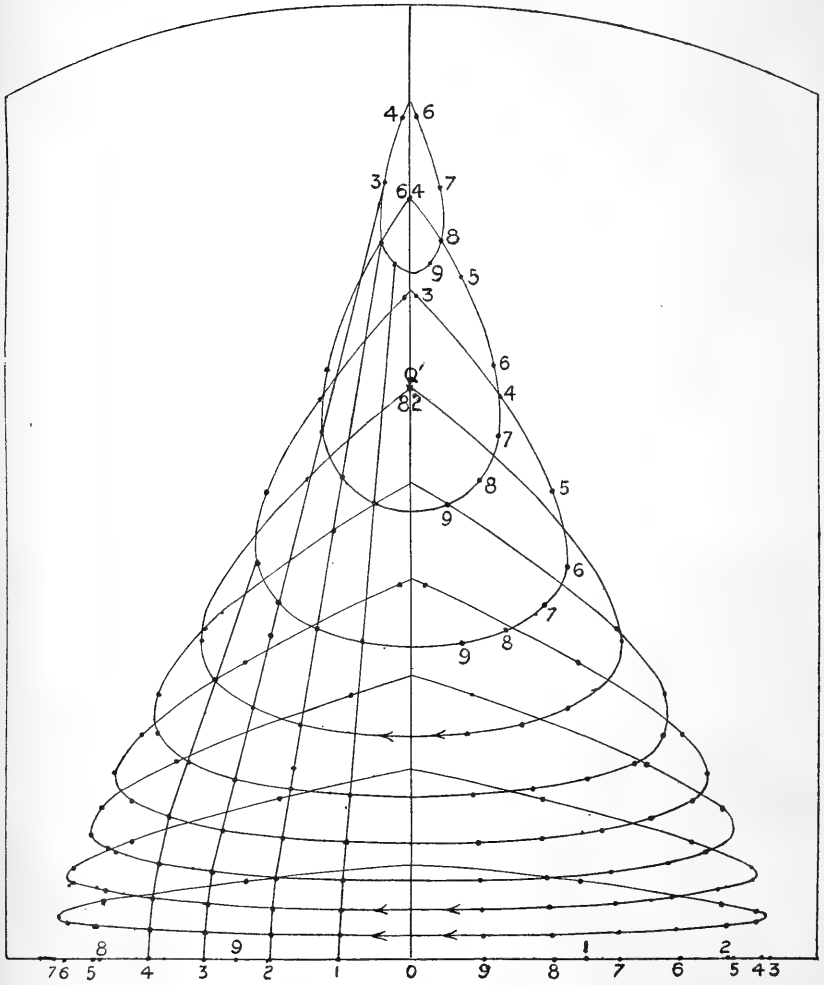

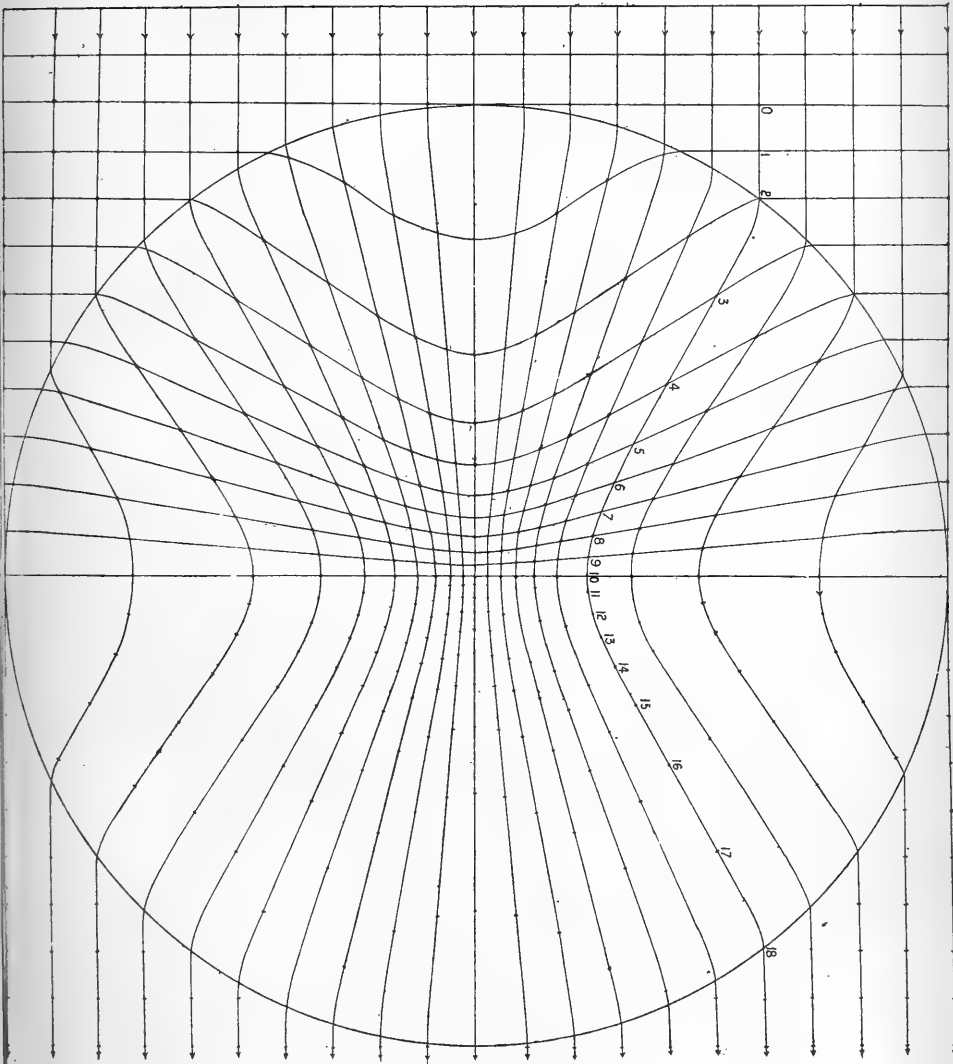

§ 12. The first dynamic question that occurs to us, returning to the supposition of moving atom and of ether outside it at rest, is :—What is the total kinetic energy (κ) of the portion of the ether which at any instant is within the atom? To answer it, think of an infinite circular cylinder of the ether in the space traversed by the atom. The time-integral from any era $t=0$ of the total kinetic energy of the ether in this cylinder is $t\kappa$; because the ether outside the cylinder is undisturbed by the motion of the atom according to our present assumptions. Consider any circular disk of this cylinder of infinitely small thickness e . After the atom has passed it, it has contributed to $t\kappa$, an amount equal to the time-integral of the kinetic energies of all the orbits of small parts into which we may suppose it divided, and it contributes no more in subsequent time. Imagine the disk divided into concentric rings of rectangular cross-section $e dr'$. The mass of one of these rings is $2\pi r' dr' e$ because its density is unity; and all its parts move in equal and similar orbits. Thus we find that the total contribution of the disk amounts to

$$2\pi e \int_0^1 dr' r' \int ds^2/dt \dots \dots (12),$$

where $\int ds^2/dt$ denotes integration over one-half the orbit of a particle of ether whose undisturbed distance from the central line is r' ; (because $\frac{1}{2}ds^2/dt^2$ is the kinetic energy of an ideal particle of unit mass moving in the orbit considered). Now the time-integral κt is wholly made up by contributions of successive disks of the cylinder. Hence (12) shows the contribution per time e/q , q being the velocity of the atom; and (κ being the contribution per unit of time) we therefore have

$$\kappa = 2\pi q \int_0^1 dr' r' \int ds^2/dt \dots \dots (13).$$

§ 13. The double integral shown in (13) has been evaluated with amply sufficient accuracy for our present purpose by seemingly rough summations; firstly, the summations $\int ds^2/dt$ for the ten orbits shown in fig. 4, and secondly, summation of these sums each multiplied by $dr' r'$. In the summations for each half-orbit, ds has been taken as the lengths of the curve between the consecutive points from which the curve has been traced. This implies taking $dt=1$ throughout the three orbits corresponding to undisturbed distances from the central line equal respectively to 0, .6, .8; and throughout the other semi-orbits, except for the portions next the corner, which correspond essentially to intervals each <1 . The plan

followed is sufficiently illustrated by the accompanying Table III., which shows the whole process of calculating and summing the parts for the orbit corresponding to undisturbed distance .7.

Table IV. shows the sums for the ten orbits and the products of each sum multiplied by the proper value of r' , to prepare for the final integration, which has been performed by finding the area of a representative curve drawn on conveniently squared paper as described in § 6 above. The result thus found is .02115. It is very satisfactory to see that, within .1 per cent., this agrees with the simple sum of the widely different numbers shown in col. 3 of Table IV.

TABLE III.

Orbit $r' = .7$.

$ds.$	$ds^2.$	$dt.$	$ds^2/dt.$
.006	.000036	0.14	.000257
.137	.018769	1.00	.018769
.112	.012544	1.00	.012544
.077	.005929	1.00	.005929
.050	.002500	1.00	.002500
.048	.002304	1.00	.002304
.050	.002500	1.00	.002500
.052	.002704	1.00	.002704
Sum047507

TABLE IV.

$r'.$	$\int ds^2/dt.$	$\cdot 1 \cdot r' \cdot \int ds^2/dt$
.0	.0818	.00000
.1	.0804	.00080
.2	.0781	.00156
.3	.0769	.00231
.4	.0722	.00289
.5	.0670	.00335
.6	.0567	.00340
.7	.0475	.00332
.8	.0310	.00248
.9	.0114	.00102
Sum02113

§. 14. Using in (13) the conclusion of § 13, and taking $q=1$, we find

$$\kappa = 2\pi \cdot 002115 \dots \dots \dots (14).$$

A convenient way of explaining this result is to remark that it is .634 of the kinetic energy $\left(\frac{4\pi}{3} \frac{1}{2} (.1)^2\right)$ of an ideal globe of rigid matter of the same bulk as our atom, moving with the same velocity. Looking now at the definition of κ in the beginning of § 12, we may put our conclusion in words, thus:—The distribution of ethereal density within our ideal spherical atom represented by (11) with $K=100$, gives rise to kinetic energy of the ether within it at any instant, when the atom is moving slowly through space filled with ether, equal to .634 of the kinetic energy of motion with the same velocity through ideal void space, of an ideal rigid globe of

the same bulk as the atom, and the same density as the undisturbed density of the ether. Thus if the atom, which we are supposing to be a constituent of real ponderable matter, has an inertia of its own equal to I per unit of its volume, the effective inertia of its motion through space occupied by ether will be $\frac{\pi}{6} s^3(I + \cdot 634)$; the diameter of the atom being now denoted by s (instead of 2 as hitherto), and the inertia of unit bulk of the ether being still (as hitherto) taken as unit of inertia. In all that follows we shall suppose I to be very great, much greater than 10^6 ; perhaps greater than 10^{12} .

§ 15. Consider now, as in § 11 above, our atom at rest; and the ether moving uniformly in the space around the atom, and through the space occupied by the atom, according to the curved stream-lines and the varying velocities shown in fig. 5. The effective inertia of any portion of the ether containing the atom will be greater than the simple inertia of an equal volume of the ether by the amount $\frac{\pi}{6} s^3 \cdot 634$. This follows from the well-known dynamical theorem that the total kinetic energy of any moving body or system of bodies is equal to the kinetic energy due to the motion of its centre of inertia, plus the sum of the kinetic energies of the motions of all its parts relative to the centre of inertia.

§ 16. Suppose now a transparent body—solid, liquid, or gaseous—to consist of an assemblage of atoms all of the same magnitude and quality as our ideal atom defined in § 2, and with I enormously great as described in § 14. The atoms may be all motionless as in an absolutely cold solid, or they may have the thermal motions of the molecules of a solid, liquid, or gas at any temperature not so high but that the thermal velocities are everywhere small in comparison with the velocity of light. The effective inertia of the ether per unit volume of the assemblage will be exceedingly nearly the same as if the atoms were all absolutely fixed, and will therefore, by § 15, be equal to

$$1 + N \frac{\pi}{6} s^3 \cdot 634 \dots \dots \dots (15),$$

where N denotes the number of atoms per cubic centimetre of the assemblage, one centimetre being now our unit of length. Hence, if we denote by V the velocity of light in undisturbed ether, its velocity through the space occupied by the supposed assemblage of atoms will be

$$V / \left(1 + N \frac{\pi}{6} s^3 \cdot 634 \right)^{\frac{1}{2}} \dots \dots \dots (16).$$

§ 17. For example, let us take $N = 4 \times 10^{20}$ *; and, as I find suits the cases of oxygen and argon, $s = 1.42 \times 10^{-8}$, which gives $N \frac{\pi}{6} s^3 = .60 \times 10^{-3}$. The assemblage thus defined would, if condensed one-thousand-fold, have .6 of its whole volume occupied by the atoms and .4 by undisturbed ether; which is somewhat denser than the cubic arrangement of globes (space unoccupied $= 1 - \frac{\pi}{6} = .4764$), and less dense than the densest possible arrangement (space unoccupied $= 1 - \frac{\pi}{3\sqrt{2}} = .2595$). Taking now $N \frac{\pi}{6} s^3 = .60 \times 10^{-3}$ in (16), we find for the refractive index of our assemblage 1.00019, which is somewhat smaller than the refractive index of oxygen (1.000273). By taking for K a larger value than 100 in (11), we could readily fit the formula to give, in an assemblage in which .6 of the whole space is occupied by the atom, exactly the refractive index of oxygen, nitrogen, or argon, or any other gas. It is remarkable that according to the particular assumptions specified in § 5, a density of ether in the centre of the atom considerably greater than 100 times the density of undisturbed ether is required to make the refractivity as great as that of oxygen. There is, however, no difficulty in admitting so great a condensation of ether by the atom, if we are to regard our present problem as the basis of a physical hypothesis worthy of consideration.

§ 18. There is, however, one serious, perhaps insuperable, difficulty to which I must refer in conclusion: the reconciliation of our hypothesis with the result that ether in the earth's atmosphere is motionless relatively to the earth, seemingly proved by an admirable experiment designed by Michelson, and carried out with most searching care to secure a trustworthy result, by himself and Morley †. I cannot see any flaw either in the idea or in the execution of this experiment. But a possibility of escaping from the conclusion

* I am forced to take this very large number instead of Maxwell's 19×10^{15} , as I have found it otherwise impossible to reconcile the known viscosities and the known condensations of hydrogen, oxygen, and nitrogen with Maxwell's theoretical formula $Ns^2 = \frac{1}{2\sqrt{2}\pi} \times \frac{v}{D} = .3989 \frac{v}{D}$,

where v is the Newtonian velocity of sound in the particular gas, and D is its diffusivity, that is, its viscosity divided by its density. It must be remembered that Avogadro's law makes N the same for all gases.

† Phil. Mag., December 1887.

which it seemed to prove may be found in a brilliant suggestion made independently by FitzGerald*, and by Lorentz† of Leyden, to the effect that the motion of ether through matter may slightly alter its linear dimensions; according to which if the stone slab constituting the sole plate of Michelson and Morley's apparatus has, in virtue of its motion through space occupied by ether, its lineal dimensions shortened one one-hundred-millionth ‡ in the direction of motion, the result of the experiment would not disprove the free motion of ether through space occupied by the earth.

XIV. *On the Supposed Elongation of a Dielectric in an Electrostatic Field.* By LOUIS T. MORE, Ph.D., Adjunct-Professor of Physics in the University of Nebraska§.

MUCH attention has been attracted to the so-called expansion of a dielectric in an electrostatic field, as it has been deemed an experimental proof of the theory of Faraday and Maxwell, and many investigators have experimented on it—notably, Fontana ||, Govi ¶, Duter**, Righi††, Quincke‡‡, and Roentgen§§. The results, as given by them, although many contradictions are noted, are, that most liquids and glass expand in volume when subjected to electrostatic stress, and that glass also expands in a direction normal to the lines of induction. These increments are considered too large to be accounted for except by a new and peculiar property of electricity. No experiments have yet been made on the behaviour of glass coinciding with the lines of induction. These results have been generally adopted; for example—See J. J. Thomson, 'Applications of Dynamics to Physics and Chemistry,' page 52 *et passim*, and Poincaré, *L'électricité et l'optique*, chapter xiii. And they have been adduced as an experimental confirmation of Faraday's theory. Roentgen, on the other hand, from a discussion of the results obtained

* Public Lectures in Trinity College, Dublin.

† *Versuch einer Theorie der electrischen und optischen Erscheinungen in bewegten Körpern.* Leiden, 1895.

‡ This being the square of the ratio of the earth's velocity round the sun (30 kilometres per sec.) to the velocity of light (300,000 kilometres per sec.).

§ Communicated by the Author.

|| Volta, *Lettere inedite di Volta*, Pesaro, p. 15, 1834.

¶ Govi, *Nuovo Cim.* xxi.-xxii. pp. 18-26; *C. R.* lxxxvii. p. 857.

** Duter, *C. R.* lxxxvii. pp. 828-1036; lxxxviii. p. 1260.

†† Righi, *C. R.* lxxxviii. p. 1262.

‡‡ Quincke, *Wied. Ann.* x. pp. 161, 374, 513; xix. pp. 545, 705; xxviii. p. 529; xxxii. p. 530.

§§ Roentgen, *Wied. Ann.* xi. p. 786.

by former investigators, and from experiments of his own, believes that these observed changes of volume and length are to be accounted for by electric compression of the electrodes and the heating effect of the electric charge. In support of this opinion, that at least part of the effect was due to the former, it should be noted that in every case there has been an abrupt change of potential at the surface of the dielectric. This would necessitate the action of free charges on the surface of the glass or liquid, and the attraction of these charges would produce changes in volume. In general, from the arrangement of the apparatus, it would cause an apparent expansion.

My principal aim in these experiments was to prevent any free or apparent charges on the surface of the dielectric and so obviate this criticism. As for temperature changes, they were said to be slower in action than the electrical strains, and so separable. If a solid dielectric, as glass, were charged by electrodes not in contact with it, and if the spaces intervening were filled with a liquid non-conductor of the same or nearly the same specific inductive capacity, it is evident that the potential gradient between the charged plates would be uniform and there could be nothing like a free or apparent charge on the surface of the glass. After a number of apparatus were tried, the following was found best to answer the purpose.

A brass tube (fig. 1, p. 200) 61 centim. long, 4 centim. inner diameter, and 4 millim. thick, was screwed and then soldered into a heavy iron plate. This, in turn, was fastened by screws into a ring of hard wood. Around the base of the tube a collar of brass 3.5 centim. high was soldered. The glass tube to be tested was then passed over the inner cylinder and sealed with sealing-wax to a height of 4 centim. This tube had a length of 57.5 centim., inner diameter 5.2 centim., mean thickness 2.5 millim. A third tube was fitted over these two. It consisted of three pieces, the middle part of brass, 44 centim. long, 3.5 millim. thick, 6.3 centim. inner diameter, and two end-pieces of glass which fitted tightly over the brass tube as shown in the figure. The three were then sealed together, and the whole, in a brass ring screwed to the iron base. This arrangement of glass and metal was for the purpose of insulating the brass part when the latter was charged. To prevent leakage the outer surface was painted with shellac. Great care was taken, when putting the apparatus together, to make the axes of the three cylinders coincide. The spaces between the cylinders could be filled with various liquids as desired. A thin layer of mercury, poured between

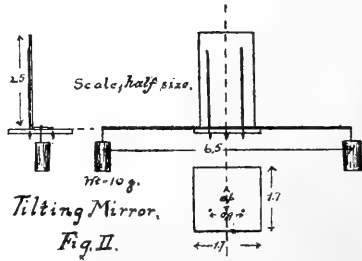
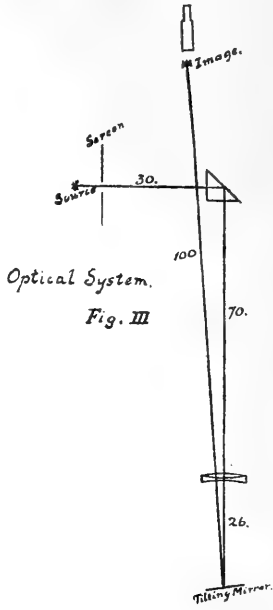
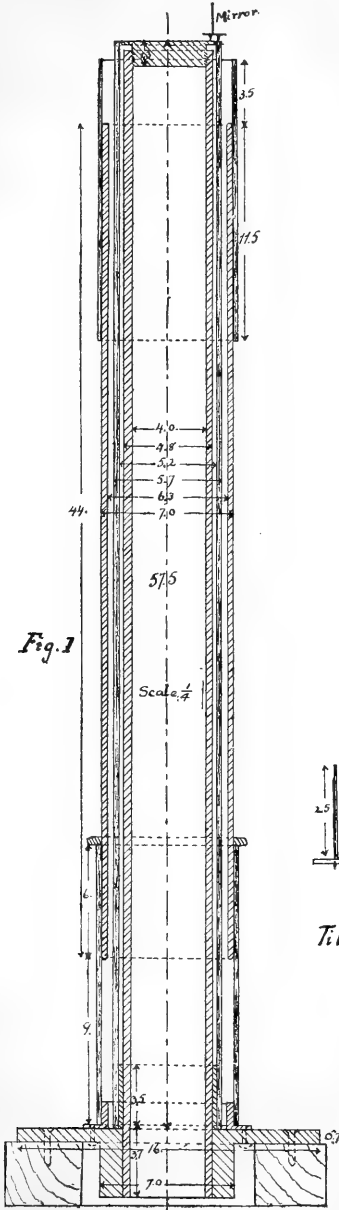

the tubes, prevented the dissolving of the wax. Of different cements (such as yellow lead dissolved in glycerine, plaster of Paris, shellac) sealing-wax held well and was convenient to manipulate.

The magnifying arrangement of the deflexion consisted of a system of optical levers (fig. 3). The light from a Welsbach burner was placed behind a metal screen pierced with a round hole one centimetre in diameter; fine glass fibres were stretched horizontally across this opening. The light, after being deflected at a right angle by a totally reflecting prism, passed through an achromatic lens to a mirror mounted on a three-legged table and then, upon reflexion, back again, through the lens and on past the prism either to one side or above. The lens had a focal length of a metre; as the screen was at that distance from it, the image of the fibres was also at a distance of a metre. The mirror, in position, is shown in fig. 1. Dimensions are in centimetres. As arranged, a vertical displacement of the image accompanied a change in the length of the glass tube.

The tilting-table and mirror (fig. 2) consisted of a small brass plate, 1.7 centim. square, with three legs made from the finest needle-points. The mirror was 2.5 centim. high and 1.4 centim. in width, and was silvered on the face and back. The effective distance between the needle-points was 6 millim. The image of the fibre was finally observed in a cathetometer microscope provided with a vertical motion micrometer screw. One division measured a deflexion of $1/200$ millim.

One division of the micrometer is equal to a change of length of

$$\frac{6}{2 \times 1000} \times \frac{1}{200} = 1.5 \times 10^{-5} \text{ millim.}$$

The microscope could be set to a quarter of a division. In using such a system it is advantageous to increase the stability of the mirror by lowering the centre of gravity of the tilting-table considerably below the needle-point. Without such an arrangement it is very sensitive to external vibrations, but by passing over the top of the table a yoke carrying leaden weights of 20 grams, all vibrations are prevented and even hard jars disturb the image but for an instant. The image during observing was perfectly steady, and after a deflexion returned to the original position accurately.

To adjust the position of the reflected ray of light, a solid brass cap was screwed into the upper end of the inner brass cylinder (fig. 1), the top extending out so that it left a space of about a millimetre between it and the glass tube. One leg

of the tilting mirror rested on the glass and the other two on the brass tube, or *vice versa*. By screwing the cap up or down a proper level of the mirror could be readily obtained.

Finally the entire apparatus was rigidly fastened to a system of heavy beams fitted on a brick pier in a basement room where the temperature was reasonably constant.

The inner tube was always connected with the ground both at top and bottom, and since the metal legs rested on the head of the tube, the silvered front and back surface of the mirror was also uninsulated. A sheet of card-board covered with tin-foil fitted closely to the top of the glass tube, and on being grounded prevented any direct attraction between the mirror and the charged electrode. The outer brass tube, or else a covering of tin-foil on the outer surface of the glass tube, as the case might be, was charged by a powerful electric machine capable of giving a spark, of great volume, eight or more inches in length. One pole of the machine was grounded. A Lane unit jar, with a spark-micrometer of brass balls two centimetres in diameter, was included in the circuit and one ball grounded. The jar stood near the apparatus, that there might be little difference of potential between the tubes. The fall of potential along the entire line was so small that the sparks passed as readily between the balls of the jar as between those of the machine. When they were set at the same distances, sparks usually passed simultaneously.

To test the sensibility of the apparatus several experiments were made by determining the elasticity of the glass tube. A table was prepared with three legs that rested upon the top of the glass tube alone, on which weights could be laid. The results of a set of readings are given below. As the only object was to test the sensibility of the apparatus, the experiment was performed without especial care to avoid changes of temperature or other causes which affect the zero-point when a sensitive arrangement is used.

Deflexions in Divisions of Micrometer.

Wt. 500 grams.

Wt. put on.	Wt. taken off.
21·3	14·2
16·7	14·0
16·25	14·8
16·65	11·5
13·4	12·6
<hr/>	<hr/>
16·86	

Weight 1000 grams.

Wt. put on.	Wt. taken off.
28·7	31·2
39·2	29·4
30·3	27·7
32·0	29·6
32·0	

The first column gives the absolute elongation ; the second indicates the gradual change of the zero. The mean deflexion is about double for the increased weight. The modulus of elasticity, which should be about 3×10^{11} , is determined from the following data :—

Inner diam. of glass tube	5·80 cm.
Wall thickness	0·25 cm.
Cross-section	4·25 cm.
Length	55·00 cm.
Weight	1000 grams.
Change of length	32·0 div.
Value of one division	$1·5 \times 10^{-6}$ cm.
E (Young's modulus)	$2·7 \times 10^{11}$

From the value of Young's modulus obtained, it is evident that the mirror recorded changes of length approximately correct. The three cylinders were then adjusted, the intervening spaces filled with a non-conducting fluid and the outer one charged. The series of experiments described are from a very large number of attempts extending over more than two years.

The ethereal salts of acetic acid are liquids of approximately the same specific inductive capacity as glass, which was the solid used. But amyl acetate, having about the same resistance as the others, did not hold a sufficiently high charge. I then decided to try kerosine, which though of a less inductive capacity, yet would reduce the surface charge on the glass by half. With this liquid sparks of two centimetres were gotten. In spite of great care, I was troubled by the fact that when the outer cylinder was charged the glass was bent laterally. This lateral bending was easily recognizable, as it caused the field to move laterally and at the same time either up or down. By placing the tilting mirror on opposite sides of the rim of the tube opposite effects would be observed. The lateral motion was accompanied at times by an up or down motion of ten or twenty divisions of the micrometer. Occasionally, for the apparatus was adjusted many times, the lateral effect was rendered quite small ; a few times eliminated,

but then I observed no up or down motion with potentials as great as twelve millimetres, or about 33,000 volts. With a perfectly straight tube, 55 centimetres long, a lateral motion at the top of 0.013 centimetre causes a vertical displacement of one division*.

Supposing that the potential was not great enough, it was resolved to confirm the work of former investigators. The outer cylinder was removed, the space between the glass and inner brass cylinders filled with acidulated water, and the middle of the outer surface covered with tinfoil 45 centimetres long. *In no case could I observe any elongation or contraction.* A comparison with the results of Righi and Quincke shows that an elongation of at least ten divisions should have occurred.

With glass tubes Righi obtained an elongation 1/500 millimetre under the following conditions:—

Length of tube	1 m. (length of part charged not stated).
Wall thickness	1 mm.
Spark-length	1 cm. (balls 15 mm. in diameter).
Change of length	0.002 mm.

Length of tinfoil on my tube ...	45.0 cm.
Wall thickness	2.5 mm.
Spark-length	12 mm. (balls 2 cm. in diameter).
Change of length	0.

According to Righi, $\delta l \propto \frac{l(v_1 - v_0)^2}{d}$; according to Quincke, $\delta l \propto \frac{l(v_1 - v_0)^2}{d^2}$. From the former my tube should have

elongated $0.002 \times 0.45 \times 1/2.5$ (considering the potential as one centimetre spark) $= 3.6 \times 10^{-4}$ millim.; and from the latter, $0.002 \times 0.45 \times 1/2.5^2 = 1.4 \times 10^{-4}$ millim. One division of my micrometer equals 1.5×10^{-5} millim., so that the former elongation is equivalent to 24 divisions, and the latter to 9.6 divisions.

With this arrangement higher potentials were not used as the electricity leaked from the tinfoil to the base of the apparatus. For this reason, still leaving the tinfoil on the glass, the outer brass cylinder was put in place and a metallic connexion made between the two so that they should be at the same potential. On filling the intermediate space with kerosene a spark-length of two centimetres was obtained. At

* By bending the glass tube slightly by mechanical means, it was easy to confirm the statement, that if the tube bent the image of the fibres moved laterally and at the same time vertically. When the force was removed the image returned accurately to its original position whether one or two legs of the tilting mirror were on the glass tube.

this potential *I still got no deflexion* although the lowest calculation from Righi's results should have given me 38 divisions. The time of charging was varied from almost immediate sparking to a gradual increase of potential that lasted occasionally five minutes or more. Just at the time the spark passed there was often a sudden jar of the image, sometimes up and at other times downward. This could not have been mistaken for the phenomenon expected. A calculation from Quincke's results and formula show that this potential should have given at least 20 divisions. Thus by the observations of both experimenters I should have obtained a large deflexion. After a series of experiments with these high potentials the glass was ruptured, so that the limit of possible strain was reached. During the course of the experiments four tubes, of the best German Thuringian glass, were used to be sure that it was not a special case of a single specimen.

I next tried a hard rubber tube in the same manner as the glass. The outer cylinder was put in place and the spaces filled with kerosene. The specific inductive capacities of the two are about the same, so that the potential gradient between the charged plates was practically a straight line. The sensitiveness of the apparatus was so great that gradual changes of temperature caused the image to move slowly across the field. With sparks up to seven millimetres no change in length was noted, except the jar before mentioned at the time the spark passed. This motion was too rapid to be measured, but I guessed it to be about seven divisions. The time of charging was varied as in the experiments with glass. It is stated that this substance elongates about ten times as much as glass*.

These results, so far at variance with the statements of former investigators, have caused me carefully to study their methods and results, and one cannot but be impressed with their discrepancies. Consider first the work on change of volume. The method employed was to charge a conducting liquid in a glass thermometer and to observe the change of volume of the glass by the rise or fall of the liquid in the capillary tube.

The experiments give the following results. Govi found that when the internal liquid was water the height fell, showing an increase in the volume of the glass. With nitric acid a greater change was observed than with water, and with alcohol a much greater change than with nitric acid. Ether, when charged, rose in the tube and then fell; mercury and olive-oil showed no effect. Duter, experimenting later, states

* Quincke, Wied. *Ann.* x. p. 200.

that there is always a fall in the tube which is entirely independent of the kind of liquid in the thermometer. Quincke observed an effect analogous to Govi's, but when the bulb alone was filled with a different liquid and the capillary always with pure water, the variations were eliminated. He concludes that the variations were due to differences of surface-tension, capillarity, viscosity, and electric conductivity. But it should be noted that his original variations were in the reverse order to Govi's, as the change with water is here greater than with alcohol. Mercury often showed no change, and turpentine never. In the table*, inserted here for reference, he gives this effect for water and mercury, but unfortunately impairs the value of his deductions by not using the same thermometer in the two cases.

		6 Leyden Jars.			
Therm.	No. 11.	40	20		
	Water.....	5·68 †	2·10		
	Mercury...	3·41	1·25		
				3 Jars.	
Therm.	No. 16.			20	10
	Water.....	2·787	0·755	2·669	0·789
	Mercury...	2·728	0·510	2·357	0·615

The first table is for the case when liquid fills both the bulb and the capillary; the second, when water alone is used in the capillary. It will be seen that the variations are not accounted for, and indeed Quincke states that this remaining variation must be due to the difference of the conductivity for heat of the two liquids. But this is hardly an adequate explanation, as the variations in the second table are greater for the smaller charges of electricity. It also seems to cast a doubt on the cause of the expansion, for if the relative conductivities for heat of mercury and water can change an observation from 0·51 to 0·75, the entire heating effect of the charge might well cause serious changes in the amount of deflexion observed.

Experimenting with changes of volume in liquid dielectrics, Quincke found that most of them expand when charged, but that others, as the fatty oils, contract. Roentgen repeated these experiments, using two different methods, and found in no case a contraction. He finally concludes that all cases may be accounted for by an increase of the temperature, and the attraction of the charged surfaces.

* Quincke, *Wied. Ann.* x. p. 177.

† Expansion is in millionths of the original volume. The numbers 40, 20, &c., are the relative charges from a unit jar.

Relation between strains and thickness of dielectric :—
 Duter found the volume, at the same potential-differences, to increase inversely as the thickness within a probable error of five per cent. Righi confirms this from his experiment on glass tubes, but Quincke, using both thermometers and tubes, finds the increase to be inversely proportional to the square of the thickness. This is in accordance with Maxwell's formula for the strain in the medium. In support of this law he gives on page 190 a table for changes of volume, and on page 382 for changes in length. Changes are in millionths of the original dimensions. An examination of the table shows that errors in this law are very much greater than the sensibility of his apparatus warrants, especially in tubes whose thickness varies to a considerable extent.

Therm.	Thick-ness.	Spark-length in mm.					
		1.	2.	3.	4.	5.	6.
	mm.						
30	0.142	2.883	10.670				
32	0.203	1.756	7.440	15.920			
18	0.258	1.310	3.960	8.071			
23	0.271	0.980	3.014	6.110			
22	0.286	0.739	2.662	7.025	11.770		
21	0.319	0.604	1.971	4.088	6.651		
17	0.346	0.742	2.042	3.608	5.889	8.592	
61	0.407	0.149	0.736	1.658	2.950	4.372	6.046
60	0.591	0.058	0.190	0.554	0.744	1.028	1.524

Tube.	Thickness.	Spark-length in mm.				
		1.	2.	3.	4.	5.
	mm.					
15	0.092	0.50	2.26	5.63	13.68	
19	0.150	0.44	0.97	2.79	4.92	10.19
28	0.160	1.54	2.03	4.96	7.07
27	0.184	2.09		
29	0.194	1.40	2.59	
26	0.230	0.72			

To account for some of these discrepancies it is important to compare their apparatus with mine. In the first place, as Righi and Quincke used a system of rigid mechanical levers all lateral distortions, which were so prominently in evidence in my experiments, would show in theirs as a change of length alone, resulting from the bending. This would be

especially noticeable in Quincke's method, which was to stretch fine glass fibres horizontally between two supports. He also gives prominence to the fact, that if a bent glass tube, or one not uniformly thick, be used there is a large amount of distortion due to the non-uniformity of the field. This irregularity must also occur when thermometers are employed, as it is naturally difficult to blow a bulb perfectly spherical, and also everywhere uniform in thickness. Quincke, on page 190, states, "that thermometer No. 34 had a bulb of somewhat irregular shape and wall thickness, so that the inner portions of the bulb on electrification would be especially affected. It is therefore not comparable with the others, and is included only because it shows the greatest change of volume which I have been able to observe in glass." This thermometer showed an expansion of 68.36 where No. 9 of the same glass, of practically the same thickness and with the same difference of potential, gave only 5.277. This great difference due to irregularity of shape makes one wonder whether the expansion of No. 9 might not partly result from the same causes. Also heating effects would be less evident in my experiments as the thicker glass and lower potential gradients employed would reduce this effect.

From the results of my experiments, taken with the conflicting evidence of former investigators, it is not probable that the stress occurring in the æther when a dielectric is electrostatically charged causes a mechanical deformation of the substance. At least if there is such an action it must be extremely minute—perhaps a slight rearrangement of the molecular structure—as an effect so large as one expressed by the formula $KH^2/8\pi$ could not have escaped my notice. Though it might have been expected that such æthereal stresses would change the length of a dielectric both along and at right angles to the lines of induction, yet as one of these is a tension and the other a compression of equal amounts, it is difficult to see how any change of volume other than a differential effect would result, whereas Quincke finds that the change of volume is nearly three times as large as the linear expansion.

In conclusion, the evidence that the stress in the æther denoted by Maxwell's formula $KH^2/8\pi$ is accompanied by a mechanical strain resulting in the deformation of the charged substance, is also not verified by experiments in allied fields of investigation. We may not infer from the Kerr effect of dielectric double refraction that such a mutual action exists, since the Kerr effect may be either positive or negative. Some dielectrics, as glass, give an effect equivalent to a

mechanical compression along the lines of force, and others, as resin, a mechanical expansion; whereas Maxwell's formula in all cases calls for tension alone.

Let us suppose that the Kerr effect can be explained by a mechanical compression produced by the charged electrodes.

The following calculation makes clear that this deformation is not sufficient to produce the observed changes of length normal to them:—

Let $V = 2$ cm. spark = 130 c.g.s. units.

$d = 0.25$ cm.

$K = 5.$

$E = 3 \times 10^{11},$

Then $F/S = \frac{K(V_1 - V_0)^2}{8\pi d^2} = 54000$ dynes.

The change of length along the lines of force equals

$$\frac{F}{S} \times d/E = 54000 \times \frac{0.25}{3} \times 10^{-11} = 4.5 \times 10^{-8} \text{ cm.}$$

From Poisson's ratio of 0.25, the change of length normal to the lines of force equals 1.1×10^{-8} cm. My tube was 57 cm. long, giving a total change of length of 6.3×10^{-6} mm. This corresponds to less than half a division of the micrometer-screw and hence could not have been observed.

From experiments of D. B. Brace* on the action of a magnetic field upon transparent media—"We may also conclude, according to Maxwell's view of the state of polarization and stress in such a medium, that the pressure at right angles to, and the tension along, the lines of force (equal in both cases to $H^2/8\pi$) affect the propagation of light by an amount less than $2.0 \times 10^{-14} \lambda$ for a c.g. s. unit of intensity per centimetre."

Note.—In 1895 the writer published an article† "On the Changes in Length of Iron Wires by Magnetization," and, induced by his interpretation of Maxwell's theory, he made a correction for an elongation due to the strains in the medium proportional to $B^2/8\pi$, which materially altered the interpretation of the results obtained. The paper aroused some criticism which appeared in volume liii. of 'Nature.' Dr. Chree and Dr. E. Taylor Jones argued that the true correction was a contraction. Professor J. A. Ewing wrote:—"For some time I have been aware that the passage referred to in my book on the 'Magnetic Induction in Iron' requires correction. The

* Brace, *Phil. Mag.* xliv. p. 349.

† *Phil. Mag.* (1895); *Phys. Rev.* iii. p. 210.

magnetic stress $B^2/8\pi$, is there spoken of as if it were of the same nature as a simple longitudinal stress of compression, producing a contraction of the length in consequence of the elasticity of the metal... But I see no ground for treating this purely hypothetical strain as a 'correction' to be applied, either one way or the other, to the observed changes of length." Mr. L. R. Wilberforce concurred in this opinion. To answer these criticisms it was necessary to devise an experiment that would isolate this effect from all others. As I saw no way of doing this in the case of iron I turned to the analogous case of a dielectric in an electrostatic field; for since Quincke had stated that the variation in the length was proportional to $H^2/8\pi$, it seemed that most of the effect was due to this stress. My recent experiments compel me to think that my original correction was erroneous and that Professor Ewing was right.

XV. *On a Theorem analogous to the Virial Theorem.*

By Lord RAYLEIGH, F.R.S.*

AS an example of the generality of the theorem of Clausius, Maxwell † mentions that "in any framed structure consisting of struts and ties, the sum of the products of the pressure in each strut into its length, exceeds the sum of the products of the tension of each tie into its length, by the product of the weight of the whole structure into the height of its centre of gravity above the foundations." It will be convenient to sketch first the proof of the purely statical theorem of which the above is an example, and afterwards of the corresponding statical applications of the analogue. The proof of the general dynamical theorem will then easily follow.

If X, Y, Z denote the components, parallel to the axes, of the various forces which act upon a particle at the point x, y, z , then since the system is in equilibrium,

$$\Sigma X=0, \quad \Sigma Y=0, \quad \Sigma Z=0.$$

If we multiply these equations by x, y, z respectively, and afterwards effect a summation over all the particles of the system, we obtain a result which may be written

$$\Sigma[x \cdot \Sigma X + y \cdot \Sigma Y + z \cdot \Sigma Z]=0. \quad \dots \quad (1)$$

The utility of the equation depends upon an alteration in the manner of summation, and in particular upon a separation

* Communicated by the Author.

† 'Nature,' vol. x, p. 477, 1874; 'Scientific Papers,' vol. ii, p. 410.

of the forces \mathbf{R} (considered positive when repellent) which act mutually between two particles along their line of junction ρ . If x, y, z and x', y', z' be the coordinates of the particles, we have so far as regards the above-mentioned forces,

$$X(x' - x) + Y(y' - y) + Z(z' - z) = R\rho ;$$

or with summation over every pair of particles $\Sigma R\rho$. The complete equation may now be written

$$\Sigma(Xx + Yy + Zz) + \Sigma R\rho = 0, \quad . . . \quad (2)$$

where in the first summation X, Y, Z represent the components of the *external* forces operative at the point x, y, z . In Maxwell's example the only external forces are the weights of the various parts of the system (supposed to be concentrated at the junctions of the struts and ties), and the reactions at the foundations.

The analogous theorem, to which attention is now called, is derived in a similar manner from the equally evident equation

$$\Sigma[x \cdot \Sigma Y + y \cdot \Sigma X] = 0. \quad . . . \quad (3)$$

We have to extract from the summation on the left the force \mathbf{R} mutually operative between the particles at x, y, z and at x', y', z' ; and we shall limit ourselves to the case of two dimensions. If X, Y be the components of force acting upon the latter particle, ρ the distance between the particles, and ϕ the inclination of ρ to the axis of x , we have

$$Y(x' - x) + X(y' - y) = R\rho \sin 2\phi ;$$

so that if now X, Y represent the total *external* force acting at x, y , (3) becomes

$$\Sigma [xY + yX] + \Sigma R\rho \sin 2\phi = 0. \quad . . . \quad (4)$$

where the first summation extends to every particle and the second to every *pair* of particles.

If the external force at x, y be \mathbf{P} and be inclined at an angle α , we have

$$X = P \cos \alpha, \quad Y = P \sin \alpha ;$$

so that, if $x = r \cos \theta, y = r \sin \theta$ as usual, (4) may be written

$$\Sigma P r \sin (\theta + \alpha) + \Sigma R\rho \sin 2\phi = 0. \quad . . . \quad (5)$$

As simple examples of these equations, consider the square framework with one diagonal represented in figs. 1 and 2, and take the coordinate axes parallel to the sides of the square. Since $\sin 2\phi = 0$ for all four sides of the square, the only \mathbf{R}

that occurs is that which acts along the diagonal where $\sin 2\phi = -1$. In fig. 1 opposed forces P act at the middle points of the sides, but since in each case $\theta + \alpha = 0$, the terms containing P disappear. Hence $R = 0$.

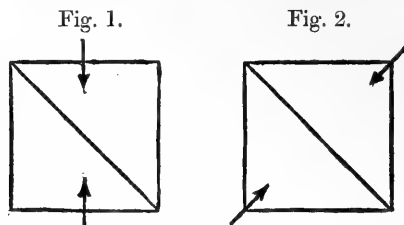

In fig. 2, where external forces P act diagonally at the unconnected corners, $\sin(\theta + \alpha) = -1$, and since $\rho = 2r$, $R = -P$, signifying that the diagonal piece acts as a tie under tension P. In neither case would the *weight* of the members disturb the conclusion.

The forces exercised by the containing vessel upon a liquid confined under hydrostatic pressure p contribute nothing to the left-hand member of (4). The normal force acting inwards upon the element of boundary ds is pds , so that

$$X = -pdy, \quad Y = pdx,$$

and accordingly

$$\Sigma [xY + yX] = \frac{1}{2} p \int d(x^2 - y^2),$$

vanishing when the integration extends over the whole boundary.

Abandoning now the supposition that the particle at x, y is at rest, we have

$$\frac{d^2(xy)}{dt^2} = 2 \frac{dx}{dt} \frac{dy}{dt} + x \frac{d^2y}{dt^2} + y \frac{d^2x}{dt^2},$$

so that if m be the mass of the particle, X, Y the components of force acting upon it,

$$2m \frac{dx}{dt} \frac{dy}{dt} = m \frac{d^2(xy)}{dt^2} + xY + yX; \dots \quad (6)$$

or with summation over all the particles of the system,

$$2 \Sigma m \frac{dx}{dt} \frac{dy}{dt} = \frac{d^2}{dt^2} \Sigma (mxy) + \Sigma (xY + yX) \dots \quad (7)$$

We now take the mean values with respect to time of the

various terms in (7). If the system be such that

$$\frac{d}{dt} \Sigma(mxy)$$

does not continually increase, we obtain, as in the case of the virial theorem,

$$2 \Sigma m \frac{dx}{dt} \frac{dy}{dt} = \Sigma (xY + yX). \quad \dots \quad (8)$$

It would seem that this equation has application to the molecular theory of the viscosity of gases, analogous to that of the virial as applied to hydrostatic pressure.

XVI. *The Classes of Progressive Long Waves.*

By R. F. GWYTHER, M.A.*

ADOPTING the method employed by Lord Rayleigh in his paper "On Waves" †, write

$$\phi + i\psi = F(x + iy)$$

where F is a real function, and therefore

$$\psi = F'y - F''' \frac{y^3}{3!} + \text{etc.}, \quad \dots \quad (1)$$

while the condition expressing the uniformity of pressure along the free surface, for which $\psi = -ch$, is

$$u^2 + v^2 = c^2 - 2g(y - h). \quad \dots \quad (2)$$

But now, instead of obtaining a differential equation approximately related to the free surface, proceed to eliminate y between (1) and (2), putting $\psi = -ch$.

The convergency of these expressions in the case of long waves is clear, and we easily obtain

$$F'^2 - (F'F''' - F''^2) \frac{c^2 h^2}{F'^2} + \text{etc.} \\ = c^2 + 2gh + 2g \left[\frac{ch}{F'} + \frac{c^3 h^3 F''''}{3! F'^4} + \text{etc.} \right]. \quad \dots \quad (3)$$

This mode of treatment has the merit of simplicity and also of allowing the constants introduced in the integration by approximate methods to be treated with a feeling of security.

Write (3) to a first approximation

$$\left(c^2 + \frac{c^3 gh}{3F'^3} \right) h^2 F'''' = F'^3 - (c^2 + 2gh)F' - 2gch. \quad \dots \quad (4)$$

* Communicated by the Author.

† Phil. Mag., April 1876.

As we are seeking solutions which we have reason to think rapidly convergent, put

$$F' = -c + f', \quad \dots \dots \dots (5)$$

where we consider f' small compared with c . On this assumption (4) becomes

$$\left(c^2 - \frac{gh}{3}\right)h^2 f''' = f'^3 - 3cf'^2 + 2(c^2 - gh)f'. \quad \dots (6)$$

Whenever the form of the function f' is found, the form of the free surface is given by (1) or (2).

Under the conditions stipulated we may neglect f'^3 compared with $3cf'^2$, but we can only neglect $3cf'^2$ compared with $2(c^2 - gh)f'$, when f' is small compared with $2(c^2 - gh)/3c$.

Taking this to be the case, we obtain

$$f = a \sin \sqrt{\frac{2(gh - c^2)}{c^2 - \frac{gh}{3}}} \cdot \frac{x}{h} \dots \dots (7)$$

If λ is the wave-length, we have

$$\frac{4\pi^2 h^2}{\lambda^2} = \frac{2(gh - c^2)}{c^2 - \frac{gh}{3}},$$

subject to the condition that the height of the wave shall be small compared with $2(gh - c^2)/3g$.

If, for example, $h : \lambda = 1 : 10$, we get approximately $gh : c^2 = 9 : 8$, and the height of the wave must be small compared with $2h/27$.

This wave can therefore be only of small amplitude, and cannot be the general case of the long wave. It has, on the usual theory, a group-velocity given by

$$\frac{c^3}{gh} + \frac{(c^2 - gh)^2}{2cgh},$$

which is slightly less than the wave-velocity.

Proceeding to the more general case, we have from (6), neglecting f'^3 and integrating,

$$\left(c^2 - \frac{gh}{3}\right)h^2 f''^2 = -2cf'^3 + 2(c^2 - gh)f'^2 + \text{constant}; \quad (8)$$

from this it follows that f' can be found in terms of x as an elliptic function. I do not propose to consider this further here, but it is doubtless connected with the stationary cnoidal wave of Korteweg and de Vries*.

* Phil. Mag., May 1895.

When f'' and f' vanish together, the constant in (8) is null, and the solution is completed by

$$f = a \tanh mx,$$

where $ma = \frac{c^2 - gh}{c}$, and

$$m^2 h^2 = \frac{c^2 - gh}{2 \left(c^2 - \frac{gh}{3} \right)}.$$

Hence

$$\frac{a^2}{h^2} = \frac{2(c^2 - gh) \left(c^2 - \frac{gh}{3} \right)}{c^2},$$

and c^2 must be slightly greater than gh , whereas in the harmonic periodic wave previously considered it was necessarily slightly less.

This case represents a low solitary wave of Scott Russell, and the expression for $\phi + i\psi$, now obtained from the equations, is that assumed by Mr. McCowan* in his investigation of the properties of that wave.

A point of interest is that the relation $c^2 = gh$, found by the received method as giving the velocity of a long wave, corresponds to a simple case of the cnoidal wave (8).

If we retain the term in f''^3 in (6) we obtain the most general case of the elliptic function waves. In the case of the solitary wave,

$$f' = \frac{2(c^2 - gh)}{c + \sqrt{gh} \cosh 2mx}, \quad \dots \dots (9)$$

where, as before,

$$m^2 h^2 = \frac{c^2 - gh}{2 \left(c^2 - \frac{gh}{3} \right)}.$$

From this the form of the free surface is readily found by (2).

The form of f is also easily found to be

$$f = h \sqrt{c^2 - \frac{gh}{3}} \log \frac{\sqrt{c + \sqrt{gh}} + \sqrt{c - \sqrt{gh}} \tanh mx}{\sqrt{c + \sqrt{gh}} - \sqrt{c - \sqrt{gh}} \tanh mx}.$$

The highest wave of this type can be determined by the method Sir George Stokes has taught us. We must determine the relation between the parameters c and h in order

* Phil. Mag., July 1891.

that the point for which $u^2 + v^2 = 0$ may be at the apex of the wave, and not outside the fluid, as it will generally be.

This condition is found to lead to

$$c \sqrt{gh} \cos 2my + 2gh - c^2 = 0, \quad \dots \quad (10)$$

which can be satisfied, since $c^2 > gh$. With this we have of course to combine

$$y = h + \frac{c^2}{2g}, \quad \dots \quad (11)$$

and the relation between the parameters is found to be very approximately

$$c^2 = \frac{5gh}{3}, \quad \dots \quad (12)$$

giving $\frac{5h}{6}$ for the elevation in the highest wave. These values, however, hardly lie within the limits of this paper, since in this extreme case $f':c$ will have the value .46 at the crest of the wave.

XVII. *Cosmic Evolution*. By Prof. A. W. BICKERTON *.

IN this paper the term galactic system will mean not only the milky way, but also the caps of nebulae at its poles. The term milky way will be used to imply the galaxy itself. The term cosmic system will be applied to aggregations of dimensions comparable to the Magellanic clouds and to our own galactic system. (In my earlier papers these masses were called universes; but Lord Kelvin and Lord Rayleigh independently pointed out that this name might mislead, I have consequently substituted cosmic systems.) The term cosmic system of the first order applies to aggregations without definite structure, in which no general collision has occurred. In systems of the second order, a single general collision has taken place, and the symmetry is perfect. All other cosmic systems are of the third order. In these more than one general collision has occurred, and there is too much symmetry to be of the first order, and too little symmetry to be of the second. The visible universe (the galactic system of which our solar system is a part) is consequently a system of the third order.

The group of recently-discovered monatomic elements that have no combining power, namely, helium, neon, argon, crypton, and xenon, I call cosmic pioneers. They are practically

* Communicated by Prof. A. W. Rücker, Sec.R.S.

always independent atoms, and probably play an important part in laying the foundation of an incipient cosmic system, helium being the most important. Possibly these elements have no other function than this, as deductions from their properties suggest that they must largely pass out of cosmic systems before the system matures. Hydrogen plays the same initial part, but it is more than a cosmic pioneer; it has important functions in cosmic systems of all orders.

This paper is chiefly devoted to grazing and whirling collisions of celestial bodies.

Grazing collisions of stars were discussed before the Royal Society by Dr. Johnstone Stoney more than thirty years ago. The formation of double stars and new stars by such an occurrence was suggested by him, as well as the probability of the existence of dead suns in countless hosts.

The especial point I wish to forward is that a grazing impact will generally result in the formation of a new body, whilst the two struck stars proceed on their journey; as it were, flint and steel have struck and have cut off a part from each other, that results in an intensely heated spark.

Because the non-colliding parts are but little affected by the collision I call such a phenomenon a "partial impact."

With stars of the same order of dimensions that our sun has, the velocity developed by mutual attraction will be hundreds of miles a second. When by impact this motion is converted into heat in the coalesced parts, the temperature will be practically the same, whatever the amount struck off; if the graze be small, the attractive power of the new body will also be small, and it is evident that the velocity of the molecules may be great enough for every molecule to have more than the critical velocity; each molecule as it reaches the surface will consequently leave the body, never to return.

The temperature may easily be from ten to a hundred million centigrade. It will of course vary with the chemical composition.

Thus is produced in less than an hour a fiery mass expanding about a million miles an hour, and this increase in size will cause for a time an increase in brilliancy. Presently, however, the radial direction of the molecules will tend to cause their motion to become parallel, and will lessen the number of molecular encounters, and consequently the amount of radiation, so that after a time our bright star becomes a planetary nebula. In a year or so each molecule is wandering alone; the brilliant body and the nebula are gone. The body has lost its light, not by cooling, but by being too hot to hold together.

The two stars that struck have been heated where they were sheared, and they are separating at a speed of hundreds of miles a second. Hence the spectrum of our nova is made up of a continuous spectrum, with broad, bright, indistinct bands produced by the expanding gas, and on this band are superimposed two other lines, bright or dark, dependent on the position from which we view the lake of fire produced by the impact.

Obviously the tangential retardation will cause rotation, and the cut stars may alternately show their light and dark faces. Thus two variable stars are produced at once; generally this variability will tend to die out more quickly in one than in the other, yet there are many such pairs still existing.

It is certain that such pairing is not the result of chance. Whatever the explanation offered to account for variable stars must account also for the existence of pairs. (The accompanying diagram represents such a series of phenomena. With bodies of solar density the time taken to produce the changes shown in the series is less than two hours. The mass of the bodies makes no difference in the time, as with bodies of equal density the velocity acquired by gravitation is proportional to the diameter.)

The middle body attracts and retards the escaping stars, and may wed them into a pair.

Then, were no other agency to come into play, the pair would return to impact again, but long before they attain aphelion distance the central mass (consisting as it does of gas above the critical velocity) will have fled into space.

Hence the only force that attracts the stars back again is their own mass, and consequently, instead of colliding, the stars move in the ordinary double-star orbit. Double stars, when first connected, would be variable, and would be associated with nebulæ; this is actually the case, and any satisfactory account of double stars must explain these facts.

If the two stars had had a considerable proper motion they would not have been orbitally connected, and they would constantly increase their distance from each other.

This is doubtless the condition of the unassociated variable stars that are in pairs, and it is possible that their increase in distance could be observed.

Supposing too much had been cut off and coalesced, and the attraction were consequently too great for the heat to give *every* molecule more than its critical velocity; on attaining equality of temperature the light atoms would rob the others of their energy and escape.

Diagram showing an Impact of two dead Suns, forming a temporary and two variable Stars.

Fig. 1.—Pair of stars distorted and coming into impact.

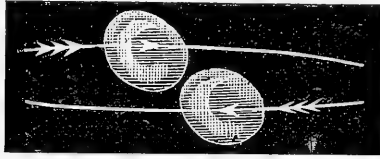

Fig. 2.—Pair of stars in impact.

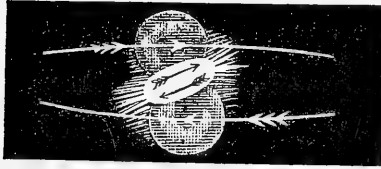

Fig. 3.—Stars passing out of impact, and formation of third body.

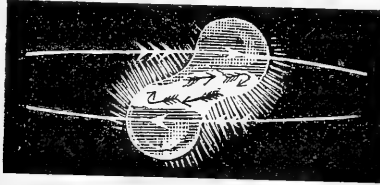

Fig. 4.—Showing entanglement of matter in each body.

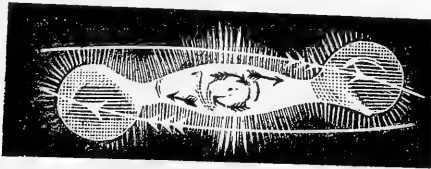
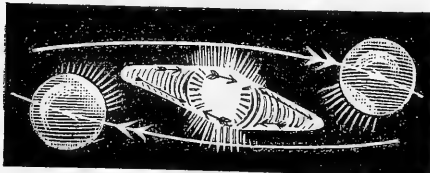

Fig. 5.—Two variables and a temporary star.



Hydrogen at the same temperature has sixteen times the tendency to escape that oxygen has, and two-hundred and eight times that of lead. This tendency of the chemical elements to sort themselves I call "selective molecular escape."

Hence at every cosmic impact of dense bodies some light molecules leave with such extreme velocity as to escape not merely the mass, but the galactic system altogether. These molecules wander in space, perchance to other cosmic systems.

Another agency is at work giving motion to free molecules. Radiant energy is caught by cosmic dust of all dimensions. Sir W. Crookes's experiments on "Radiant Matter" suggest that free molecules do not take up or give out radiation. (Dr. Johnstone Stoney has lately suggested to me that this point is unimportant, as even should the molecules absorb radiation, this energy will increase the velocity of the succeeding rebound.) But when slowly moving light molecules touch this heated dust, it will bound off in the same way that molecules fly with increased velocity from radiometer-vanes. Thus radiant energy is converted into heat, and this into potential energy.

There are other agencies by which light atoms are liberated from cosmic systems to wander indiscriminately. Such atoms do work against the attraction of systems, and where potential is highest they move slowest.

Where they thus linger they tend to accumulate. The potential of this part of space lessens, and the work required to reach these positions not being so great as at first, oxygen and other heavier molecules get there, increasing the density; and oxygen also tends to produce non-volatile compound molecules.

These would coalesce; but helium and the other cosmic pioneers do not combine, they remain permanently gaseous. Thus a primary cosmic system is incipient. Dense bodies sent out of cosmic systems by the interaction of three bodies would generally pass through old cosmic systems where matter is in dense masses, but evidently not through such vast gaseous aggregations as the incipient cosmic systems. The bodies would be retarded by the friction produced, and perchance volatilized, forming nuclei in the general mass; their mutual attraction would cause denser aggregations to occur, and a cosmic system of the first order would be produced. Two such systems colliding produce a system of the second order. This, colliding with any other cosmic system, produces a system of the third order. Our own galactic system is very probably a tertiary system.

The kinematic condition of the impact would exactly produce such a system. It is now known to be a rough double spiral of stars, with sprays and streams of stars and two caps of nebulae. It is not difficult to picture the kinematic conditions necessary to form such a rough ring, or double spiral of stars with polar caps of nebulous matter.

Let us assume a complete whirling coalescence of two cosmic systems in which the part coming into collision is considerable. This heated part is in the centre of the system. Here all the material is volatilized, and the pressure produced can find no relief save axially; hence the system is, as it were, a short cannon open at each end, and the discharged gas spreads itself over the poles of the system.

This discharge, that is commenced by pressure, is finished by molecular escape. Globular nebulae form in this gaseous matter by the attraction produced by wandering bodies plunging into the gas. The globular nebulae so produced attract one another and become double nebulae; they are then wrought into spindles, spirals, dumbbells, or rings by the kinematic peculiarities of the varying depths of impact.

It is significant that temporary stars, planetary nebulae, and all the bodies likely to be produced by the impact of stars are in the milky way; and all the forms of nebulae deduced as resulting from the impact of nebulae are where we should expect them to be, namely, at the poles of the milky way.

If this generalization represents the mode of nature's action, then there is a possibility that the entire cosmos is immortal, and the present order but a phase of an eternal rhythm.

The sequence of these agencies is as follows:—

- (1) Diffusion of heat by radiation.
- (2) This radiation, falling on the dust of space, heats it.
- (3) The heat of this cosmic dust is taken away by slowly moving light molecules having their velocity increased.
- (4) Free molecules are also sent out of systems by partial impacts, by selective molecular escape, and other agencies.
- (5) Free molecules will remain longest in the position of maximum potential where their motion is least, and will consequently tend to aggregate in the empty parts of space.
- (6) By the interaction of three bodies the velocity acquired by one sometimes takes it out of the cosmic system.

DIAGRAM OF COSMIC EVOLUTION

APPROACH OF BODIES WITH ESCAPE

THREE BODIES - ORBITS INDETERMINATE
VELOCITIES ALTERED
ONE INCREASED SOMETIMES SUFFICIENTLY TO ESCAPE

TWO BODIES - ORBITS HYPERBOLIC
FINAL VELOCITIES THE SAME AS BEFORE APPROACH

TWO BODIES IMPACT

CONJUNCTIVE

WHIRLING

DENSE

SINGLE BODY

WITH ASSOCIATED PLANETS

SOLAR SYSTEM

RARE

MIXED

REGULAR & TERTIARY SYSTEMS

GAZEOUS

ANGULAR NEBULAE

RARE

MIXED

REGULAR & TERTIARY SYSTEMS

GAZEOUS

ANGULAR NEBULAE

RARE

MIXED

REGULAR & TERTIARY SYSTEMS

GAZEOUS

ANGULAR NEBULAE

RARE

MIXED

REGULAR & TERTIARY SYSTEMS

These bodies offer interesting problems. They are of astronomical importance. They may explain a few Nebulae & also perhaps ETA ARGUS.

Radiation falls on the dust of Space, is absorbed & warms it. Cold molecules touch this dust (as a warmer body) & become excited & ultimately radiate by fluorescence of high potential.

HYDROGEN & HELLIUM ESCAPE
MATERIAL OF ALL CHARACTER SENT OUT DURING FORMATION

GAS SENT OUT DURING FORMATION BY RADIANT ENERGY

REGION OF HIGH POTENTIAL WHERE MATTER IS SPARSE
FORMATION OF COSMIC SYSTEMS

FIRST ORDER

PARTIAL

DENSE

IT DIVIDES INTO

CENTRAL CONCENTRATED MASS

COMPLETE DISPERSION

TEMPORARY NEW STARS

PLANETARY NEBULAE

SELECTIVE MOLECULAR ESCAPE

LIGHT MOLECULES ESCAPE

DISPERSES

RARE

DOUBLE NEBULAE

IT DIVIDES INTO

TWO ORIGINAL MASSES

CENTRAL COALESCE MASS

SPINDLE NEBULAE

SPINDLE NEBULAE

SPINDLE NEBULAE

SPINDLE NEBULAE

SPINDLE NEBULAE

SPINDLE NEBULAE

SPINDLE NEBULAE

SPINDLE NEBULAE

SPINDLE NEBULAE

SPINDLE NEBULAE

SPINDLE NEBULAE

SPINDLE NEBULAE

SPINDLE NEBULAE

SPINDLE NEBULAE

SPINDLE NEBULAE

SPINDLE NEBULAE

SPINDLE NEBULAE

SPINDLE NEBULAE

* Selective Molecular Escape will work in all impacts tending to convert the gases into shells like a fly, but the lighter being on the outside is often escaping all together.

- (7) Hydrogen and the cosmic pioneers then become a trap for wandering bodies that tend to be stopped and converted into dense nebulæ.
- (8) These dense nebulæ tend to attract surrounding gas; they cool and shrink, some ultimately forming solid bodies.
- (9) These bodies, by mutual attraction, give density to the new cosmic system.
- (10) Such systems are of the first order.
- (11) The impact of systems of the first order produces systems of the second order.
- (12) Any other impacts produce systems of the third order, of which our galactic system is a type.
- (13) The coalescence of two cosmic systems does not necessarily, as a final result, produce a system of a larger mass than the two original systems from which it was formed, as many agencies are tending to send matter out of the coalesced mass.
- (14) It is thus seen that dissipation of energy is but a part of a complex cyclical process; and there is consequently the possibility of an immortal cosmos in which we have neither evidence of a beginning nor promise of an end, the present being but a phase of an eternal rhythm.

The accompanying diagrammatic scheme illustrates these agencies. It must be noted that bodies and systems are printed in italic capitals; and where several such are one above another it implies sequence of phenomena.

XVIII. *On some Effects of Twist on the Thermo-electric Qualities of Iron.* By K. TSURUTA (Tokyo, Japan), in Göttingen*.

THIS formed one of my old subjects of investigation, in fact, should have formed the continuation of my papers published in the 'Journal of the College of Science, Imperial University, Tokyo.' In 1892 some preliminary experiments, and in 1895 the present series of experiments, were carried out; but as my methods had to be improved upon, and the results then obtained appeared likely to be corrected in some or other points, I refrained from having them published along with the others. Up to this day, however, I have not been able, and still at present I see no prospect of being able, to execute my intention. On the other hand there have lately come to my knowledge some papers dealing with somewhat allied

* Communicated by the Author.

subject-matters—for example, G. Meyer's in Wiedemann's *Annalen*, and G. Maclean's in the 'Proceedings of the Royal Society of London.' Having been thus reminded of my old experiments, I have been led to do my best to give now and here an account of them, inasmuch as I believe that though unfinished and incomplete, yet if communicated to fellow-workers interested in such matters, they may not be deemed utterly worthless. In undertaking this task at a date remote from the time of actual experiments I cannot feel myself sure of being free from consequences arising out of a long dismissal of the subject-matter, although my laboratory-journal, to collect my materials from, has been kept unimpaired, and the general features of my result were at that time carefully written out. The publication of this confessedly incomplete account will, I hope, call forth my colleagues' criticism and correction, affording, I doubt not, what I myself could not till now.

G. Wiedemann, in a paper on "Magnetische Untersuchungen," after remarking that as E. Cohn has found a thermo-electric current produced in a wire, a part of which is stretched and the remainder is not, so the same might take place in regard to twisting, goes on to say that he has confirmed this by experiment, but it is not to be ascertained how he did so. At the time of my experiments I could find no paper in which the present subject is systematically treated of.

The following was one of the arrangements used in my experiments of 1892, and may be considered as corresponding to the well-known one of Lord Kelvin's in regard to the effect of longitudinal tension. A long piece of wire to be examined, being passed through a brass bar, was clamped to it at its middle part. One half of the wire could be twisted by means of a torsion-head at its free end, the whole being stretched by means of leaden weights applied to the other free end. A pair of small circular brass disks was fixed on the wire near its free ends and dipped into mercury pools which were connected with the electrodes of a small galvanometer. Heat was to be applied at the clamped middle of the wire. This arrangement, simple and good in principle, presented many practical difficulties, and so no quantitative observations were made.

The arrangement adopted in the year 1895 corresponds in principle to that adopted by E. Cohn in his investigation on the thermo-electric effects of longitudinal tension. A torsion-head used was constructed in the following way:—Its outer cylindrical piece, which was to be fixed, had an inner piece (also cylindrical) fitting accurately and easy to turn. This

inner piece had a pyramidal hollow, into which there fitted accurately a solid pyramid (of course truncated). This latter consisted of two equal wedges, which had grooves, forming together a small hole along the axis of the torsion-head, and of a calibre just sufficient to allow the end of the experimental wire to pass through. A strong screw was to be driven against the bases of the two wedges, which, on being thus pushed from behind into the pyramidal hollow, embraced the end of the wire and held it firmly in position. All was made of brass. Thus the trouble of soldering once in each experiment the end of the wire to the inner piece was obviated, but at the same time the wire was laterally and considerably compressed—a thing to be avoided as much as possible, for though the portion compressed was just next to the uncompressed, yet a difference of temperature between them (exposed and unexposed to the air as they were) might produce disturbance.

The outer piece of the torsion-head had a shallow triangular groove, cut parallel to its axis and on its outer surface. One end of the unaffected part of the experimental wire was there put in, and secured in position by a number of turns of wire.

Rigidly connected with the inner piece there was a circular disk of very hard wood provided with ten notches round its periphery. These notches served the double purpose of counting the amount of twist applied and of keeping the inner piece so turned in position by means of a side ratchet. It was this disk that was taken hold of in twisting, and thus the metallic parts were entirely free from possible disturbances due to contact with the hands.

The junction at the other free end of the part to be twisted was effected by means of another arrangement very similar to the last in construction, except that the outer and inner pieces were now made a sliding pair in order to allow for the stretching of the whole wire when loaded, and that the end of it to be joined was here put between the two wedges side by side with an end of another part which was to be left unaffected.

The two pieces which formed the junctions were firmly mounted on a very strong block of wood at a distance of about 70 cm. from each other, care being taken to have them well centered in order to avoid the production of bends near the clamped ends in stretching the wire with weights. This centering and necessary adjustments were done carefully once for all, for though I had no time to demonstrate, yet it was surmised that if any bends were formed in the initial act of stretching, and were further subject to frequent

twisting and untwisting, the effects anticipated would come out considerably complicated, though otherwise simple.

Heat was applied to the second junction by means of steam sent into a hollow vessel of brass surrounding it.

To begin with, the experimental wire was well annealed, and at the same time straightened. It was cut into three parts, each of a proper length. The ends of two of these—one the longest and to be twisted, and the other to remain unaffected—were first fixed to the second junction-piece, and put in position. Then the outer end of the part to be twisted was passed through the first junction-piece, and was firmly held there, as explained above, with the help of two small spanners, so as to avoid as much as possible any arbitrary initial twisting. One end of the remaining third part, which was to remain unaffected, was secured in position as explained above. The free ends of the two idle wires were dipped in mercury contained in two test-tubes, and surrounded with a large quantity of water, the whole being then put in a box with thick wooden walls.

The galvanometer used was of low resistance, and made highly sensitive with a controlling magnet or two. The ordinary arrangement of rocker and six mercury pools served as commutator, which it was necessary to have on account of the high sensitiveness of the galvanometer with incessant changes of zero. The commutator seems to have been a considerable source of disturbance, as different metals came here into contact (I had not at that time that form of commutator which was used in my other investigations). Absolute measurements of the current produced were, to my extreme regret, reserved to later occasions; in the curves given below the current-strength is indicated only in scale-divisions.

In my arrangement there are, it will be seen, many things which must be improved or replaced by others, some of which in fact I have put on record in my journal. All these untried things must be omitted, and of the results I obtained only the following three points seem to deserve place here.

(a) As it was thought that thermo-electric effects of twist, if any, would show themselves more conspicuously in the case of iron than with other metals, as had been the case with reference to longitudinal tension, it was soft iron that I examined first of all. The experimental wire was, to begin with, subject to the tension of some leaden weights, and then it was twisted and untwisted two or three times by way of drilling; definitive observations were then made. The deflexion given as corresponding to a given amount of twist must be in reality the result of the superposed deflexions due to longitudinal tension and twist applied. The pure effect of twist can properly be

gathered from observations with small loads ; but only a few of such were made—made simply for the sake of sounding, so to speak.

In fig. 1 is given a series of observations I obtained early in the course of my investigation. It seems to establish the existence of the phenomenon of thermo-electric hysteresis with respect to twist (in my own case, combined with a certain amount of longitudinal tension).

Starting from the axis of zero twist, we have an ascending trend and then a maximum point—a feature which also exists in soft iron once stretched permanently and subject to the influence of increasing longitudinal tension. This is evidently a result of the interaction between the hysteresis and the actual and immediate effect of twist. As the amount of twist is increased, the latter soon overpowers the former, causing the curve to descend. On being untwisted the wire seems to respond, yet with the hysteresis in action. The return branch falls below the direct, continues to ascend even beyond the axis of zero twist, and not far from it attains again a maximum point, which is almost symmetrically situated with respect to the axis against the first maximum. Further untwisting produces the same state of things as on twisting. In short, the whole appearance of the curve is very similar to that of the well-known curve of magnetization and twist.

It is hardly necessary to mention after what has been said above, that as several sources of disturbance were but imperfectly eliminated in my experiments, some curves I obtained were not so good as the one just cited ; for example, the maximum points were both found on the positive or both on the negative side of the axis of zero twist. It sometimes happened that one of the cycles gone through in succession was shifted relatively to the other (fig. 2). This may be partly explained by the fact of my having merely taken scale-readings.

It is to be regretted that I did not try many samples of soft iron to see whether the hysteresis phenomenon does exist in them all. But as the samples I tried were taken at random, it seems exceedingly improbable that the phenomenon is confined to them alone.

(b) Such, I believed, might be taken as the normal type for

Fig. 1.

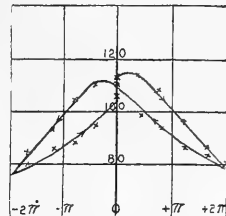
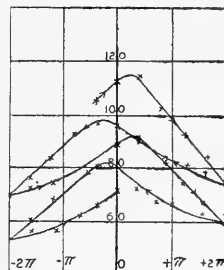
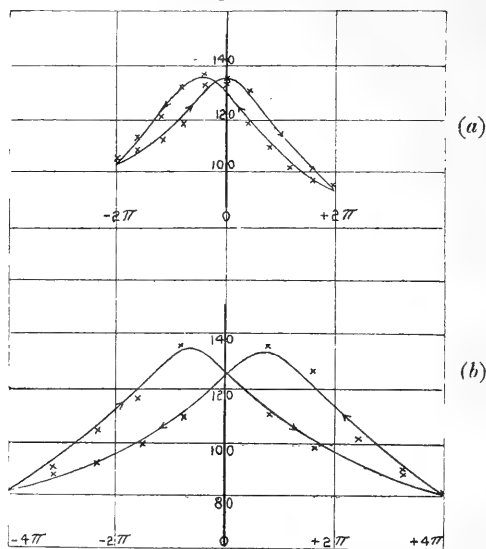

Fig. 2.



soft iron when twisted and untwisted within a moderate range and, what is not to be omitted, under a moderate amount of longitudinal tension. However, I then came across a curious circumstance as I went on to widen the range of twist. Immediately after the curve of fig. 3 a

Fig. 3.



had been obtained with the same wire and within the same range as the previous, the readings plotted in fig. 3 b were taken for the range of $\pm 4\pi$, of course with the process of drilling the wire interposed. It will be observed that with all the other features the same in both cases, the direct branches in the latter are *below* the back branches, while in the former their relative positions are *reversed*.

As this was discovered in the particular piece of wire within the range of twist $\pm 2\pi$ and $\pm 4\pi$, it seemed to me worthy of being repeatedly examined even with that particular piece; and I made many series of observations on it. It may be cited that I tried to get a number of curves for different ranges one after another, and each preceded by the process of drilling. Thus the following four sets:—

(1) $\pm 10 \cdot \frac{2\pi}{5}$, fig. 4 a; (2) $\pm 8 \cdot \frac{2\pi}{5}$, fig. 4 b; (3) $\pm 6 \cdot \frac{2\pi}{5}$, fig. 4 c; (4) $\pm 4 \cdot \frac{2\pi}{5}$, fig. 4 d. The general features of all the curves are similar, and the hysteresis phenomenon is

apparent. In the first figure the direct and back branches are distinctly separated from each other, the former lying below the latter. In the second figure the distinction between

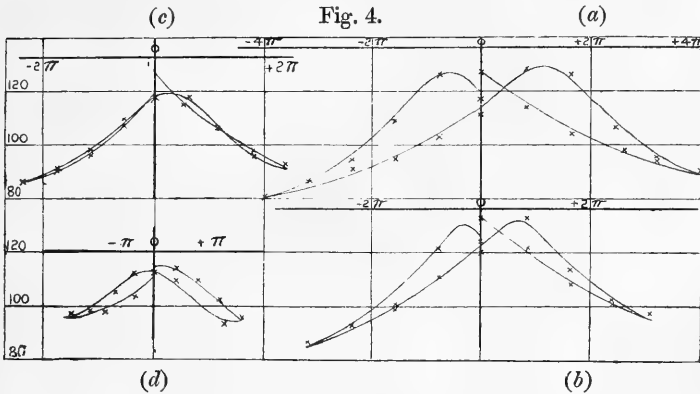

the branches becomes less, yet their relative positions are maintained. In the third figure the branches cross each other, suggesting that the metamorphosis from one type to the other is here or hereabout taking place. And in the fourth figure we have the type originally obtained, and believed to be normal.

I cannot here help referring to a very similar feature discovered in the course of Prof. Nagaoka's magnetic investigations, called by him the "reversal of hysteresis" *.

I may also cite one of my experiments made on another piece of wire cut from the same bundle as the previous, in which different ranges of twist were gone through in succession, and with all the intervening processes of drilling omitted. It was to be expected that somewhere in the chain the reversal would come into view. Suffice it to state that the experiment fully confirmed the expectation.

Experiments with still another piece, cut from the same bundle and with the range of twist widened up to $\pm 6\pi$ and even to $\pm 8\pi$, show that the type of the curves obtained is in all cases preserved, and that the direct and back branches become more and more distinct, with the two maximum points separating asunder the more widely the greater are the ranges of twist.

Examination of many different samples is also here wanting.

* Journ. of the Coll. of Science, Imperial University, Tokyo, vol. iii. pp. 189-207.

(c) The third and last result I have to communicate refers to the effect of agitation in the form of brisk tapping, which is known to be quite marked in the case of longitudinal tension. The agitation seems to be less effective in the present than in that case; yet is quite sensible. The two pairs of curves, figs. 5 *a*, 5 *b*. and figs. 6 *a*, 6 *b*, will give an idea of

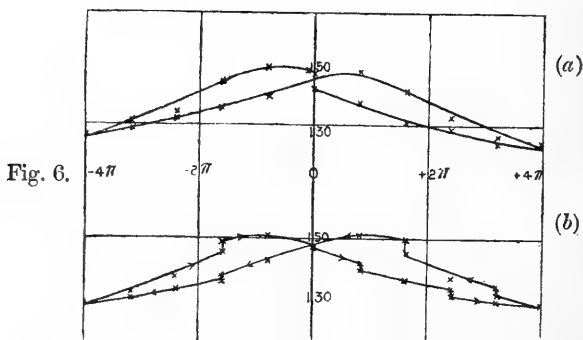
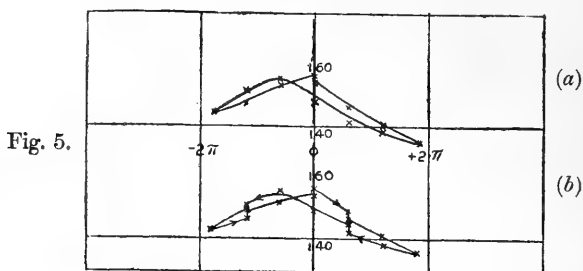

the effect. One of each pair refers to a series of observations made as usual, and the other to the immediately succeeding one in which there was interposed at some easily distinguishable point the operation of tapping (namely, with a wooden rod on the stretched rope by which the leaden weights were suspended). The former pair has the range of twist within the critical value of twist for the reversal, while in the latter it lies beyond it. The effect of agitation seems in both cases to be opposite on the direct and back branches, on one side as well as the other of the axis of zero twist; so that agitation has in figs. 5 the tendency to make the branches approach towards each other, and in figs. 6 to separate from each other. Hence it was expected that it might be possible by continual tapping to pass from the second type of the curves (*i. e.* after the reversal) to the first (*i. e.* previous to it). This seems to have been but partially fulfilled in a few experiments

tried; for I find that in some cases the branches only approach considerably towards each other, while in other cases they merely cross each other, but never entirely reverse their relative positions as expected.

It seems, then, that I was able to show by the above experiments, defective and incomplete as they were:—

(a) That in soft iron of certain kinds there exists the phenomenon of thermo-electric hysteresis with respect to twist (at least when combined with longitudinal tension);

(b) That, other things being equal, the hysteresis is reversed at a certain twist;

(c) And that mechanical agitation has its own effects, which are reversed as the hysteresis is reversed.

XIX. *On the Want of Uniformity in the Action of Copper-Zinc Alloys on Nitric Acid.* By Dr. J. H. GLADSTONE, F.R.S.*

MUCH attention is being directed at the present time to methods by which it may be possible to determine the heat evolved in the formation of alloys. Among these methods is that of the dissolution of filings of the alloys of copper and zinc in nitric acid, as compared with the dissolution of mixtures of the two metals in the same proportion. This method has been objected to by more than one chemist on the ground that there is no assurance that the same substances, and in the same relative proportions, are produced in each case. As my name appears on the British Association Committee which has adopted this method, I have felt myself under an obligation to make some direct experiments on the point.

In the Report of this Committee, "On the Heat of Combination of Metals in the Formation of Alloys," read at the Dover Meeting of the British Association (Report, 1899, p. 246) a table is given containing details of a long series of observations, which show the heat developed during the action of nitric acid on copper and zinc in various proportions, both when the metals are mixed together and when they are in combination as alloys. The difference of heat between the solutions compared has been regarded as a measure of the heat evolved by the combination of the metals in forming the alloy.

The alloys experimented upon by Dr. Galt are twenty-two in number. The results are set out in a table, and plotted in

* Communicated by the Physical Society: read May 11, 1900.

a diagram. This is reproduced, as far as the little crosses are concerned, on a larger scale in the accompanying diagram.

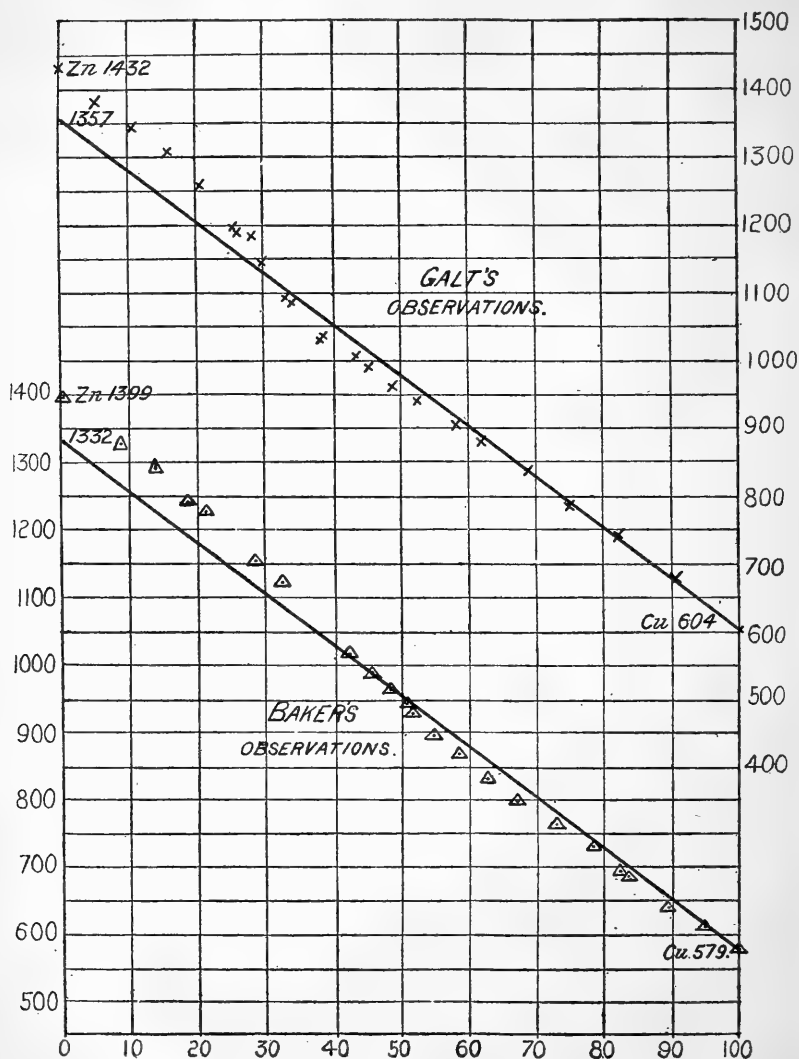

The crosses represent the absolute amount of heat evolved in dissolving one gramme of metal or alloy expressed in calories. They show at first a pretty regular decrease in the calories from the 1432 evolved by pure zinc towards the 604 evolved by pure copper. But after the alloy containing 20 per cent.

of copper, a more rapid and irregular decrease takes place till we arrive at that containing 38 per cent. of copper. From this point, or rather from copper 38·38 per cent., there is a gradual and fairly regular descent to the amount of heat evolved by pure copper.

The somewhat similar series of experiments conducted by Mr. Baker (Proc. Chem. Soc., Sept. 1899) is exhibited in the lower part of the same diagram, the resulting calories being plotted in the same way from 1399 down to 579. There is a fairly close resemblance between the two series, except that in the latter the most rapid decrease of heat does not take place till at about 54 per cent. of copper.

Through the kindness of Lord Kelvin I obtained three specimens of the alloys employed in Dr. Galt's experiments; the first containing 20·5 per cent. of copper and 79·5 per cent. of zinc, the second 38·38 per cent. of copper and 61·62 per cent. of zinc, and the third 49·1 per cent. of copper and 50·9 per cent. of zinc. The first and second specimens are not far from those which show the greatest divergence in opposite directions in the amount of heat evolved; in the third the two metals are very nearly in atomic proportions. In dissolving these in nitric acid I followed essentially the process employed by Dr. Galt, with the precautions mentioned by him.

As is well known, the reaction between nitric acid and these metals or alloys is very complicated, producing nitric and nitrous oxides and nitrogen, evolved as gases but which may be partially or wholly absorbed; while the liquid is found to contain, in addition to the undecomposed acid, nitrous acid, and nitrates or nitrites of the metals, and in some cases ammonium salts.

The gases have already been the subject of examination by several experimenters. Messrs. Acworth and Armstrong (Journ. Chem. Soc. 1877, p. 54) showed that in the case of copper in nitric acid the gas obtained is almost entirely nitric oxide, while in the case of zinc it is mainly a mixture of nitric and nitrous oxides in very nearly equal proportions. In an experiment with brass they obtained practically the same result as with copper alone. As far then as the gases are concerned, the chemical action of copper and of zinc on nitric acid is not the same; and the insignificant quantity of the nitrous oxide when brass is dissolved suggests an essential difference in the reaction between the alloy and the mixed metals.

It did not seem necessary to repeat the experiments of Armstrong, especially as the permanent gases evolved in Dr. Galt's experiments were small in quantity, at any rate in the case of the yellow alloy. My attention has therefore been

mainly confined to determining the substances remaining in solution, *i. e.* the nitrous acid and the ammonia.

The following Table gives the results; they represent in each case the amount produced by one gramme of metal, mixture, or alloy, as the case may be. Usually 0.4 gramme was dissolved in nitric acid, and the resulting solution was divided into two equal parts for determining the nitrous acid and ammonia respectively. The figures given in the Table are the mean of several observations, which were generally fairly accordant, calculated for one gramme. To these are added the results of two specimens of commercial brass of higher percentage of copper.

TABLE I.

Products of Reaction, calculated for 1 gramme.		
Substance.	Nitrous acid.	Ammonia.
Zinc	0.057	0.0164
Cu 20.5 per cent., Zn 79.5 per cent. : { mixture... alloy	0.165 0.185	0.0275 0.0098
Cu 38.38 per cent., Zn 61.62 per cent. : { mixture... alloy	0.270 0.552	0.0192 trace
Cu 49.1 per cent., Zn 50.9 per cent. : { mixture... alloy	0.431 0.568	0.0130 trace
Cu 65.8 per cent., Zn 33.5 per cent. : alloy	0.568	trace
Cu 73.5 per cent., Zn 26.5 per cent. : alloy	0.600	trace
Copper	0.605	trace

If the copper and zinc in the proportions above mentioned had been dissolved separately in acid, and their solutions then mixed together, nitrous acid and ammonia might have been expected to be in the following proportion:—

TABLE II.

Mixture of Solutions.	Nitrous acid.	Ammonia.
Cu 20.5 per cent., Zn 79.5 per cent.	0.169	0.0130
Cu 33.38 per cent., Zn 61.62 per cent.	0.267	0.0101
Cu 49.1 per cent., Zn 50.9 per cent.	0.326	0.0083

Two results stand out prominently from the above figures.

1. The chemical action of the alloys is very different from the chemical action of the corresponding mixtures of filings. It will be seen by a glance at Table I. that the alloys give much more nitrous acid and very much less ammonia than the corresponding mixtures. In fact, two of these alloys give practically no ammonia.

2. On comparing the figures for the mixtures of solutions in Table II. with the solutions of mixed metals in Table I., it will be seen that there is a notable difference both in regard to the nitrous acid and to the ammonia. This might be anticipated from the fact that, when the copper and zinc filings are mixed together, they form what has been described under the name of the "copper-zinc couple." The two metals in juxtaposition and touching at a multitude of points while surrounded by acid set up a more vigorous action, with different chemical results and no doubt a different evolution of heat*. It is probably this action which causes Dr. Galt's numbers for heat of mixtures to lie generally below the theoretical straight line joining zinc and copper in the diagram accompanying the report of the Committee.

The chemical objection therefore is well founded. It is a very serious one; but is it necessarily fatal?

Would it not be possible to take some particular alloy, determine the products of its action on nitric acid, and their relative proportions, and then determine the number of calories which would be produced theoretically in the reaction? If they agree closely with the number of calories found by Dr. Galt and Mr. Baker, there is no room for supposing that the amount of heat evolved in making the alloy is to be determined by this method. If, however, the two calculations differ, there is a residual phenomenon to be explained.

But here we encounter two difficulties.

1. Though we may know the ultimate composition of all the specimens of copper-zinc alloys experimented upon, probably not one of them is a truly definite compound. Each of them may consist of two or more alloys with some uncombined zinc or copper, as the case may be. A microscopical examination is generally sufficient to show that each is more or less heterogeneous in its character. Sir W. Roberts-Austen's table of the freezing-points of alloys of copper and zinc also indicates the mixed nature of almost every specimen

* See Journal Chem. Soc., April 1878, where the experiments of Prof. Thorpe and of Gladstone and Tribe on the production of nitrite and ammonia by means of the copper-zinc couple are described.

examined. The alloy Cu 38·38 per cent. appears, however, to be pretty uniform.

2. Supposing, however, that we had the true constitution of the specimen and the exact products of the chemical action both in solution and as gases, there would still remain an uncertainty about the number of calculated calories. The original determinations of Thomsen and the recent ones published by Berthelot are very discrepant; and the various corrections to be made, especially in regard to the gases, are too uncertain to admit of any trustworthy comparison within the narrow numerical limits with which we have to deal.

There is, however, another method of comparison which appears to be more promising. Although Thomsen and Berthelot differ as to the calories produced by any particular reaction, there is one point on which they practically agree; that is, the excess of calories in a zinc reaction over those in the corresponding copper reaction. Thomsen makes it for one gramme 750 calories, Berthelot 756 calories, which is a practical agreement (say 753 calories). Starting from 604 calories, the value, according to Galt, when pure copper is dissolved in nitric acid of sp. gr. 1·360, we should have 1357 calories when pure zinc is dissolved, *provided the chemical action were the same in each case*; and all the calorimetric results from the different specimens of alloy would theoretically lie, not upon the line drawn in Dr. Galt's diagram, but upon the straight line drawn between 604 and 1357. On referring to the diagram, we see that the little crosses fairly coincide with this line from pure copper to about the Cu 70 alloy, but beyond that there is less heat produced than the mean indicated by the straight line, the maximum deviation being at about Cu 37. Beyond that point the heat gradually augments, exceeding the mean at about Cu 30, with a somewhat irregular progress to 1432 calories, the amount experimentally obtained by Galt from pure zinc,—an excess of as much as 75 calories above the theoretical. The diagram of Baker's experiments shows the same general result, with the difference previously referred to.

Reference to Table I. will show that the products of decomposition of the nitric acid between pure copper and the Cu 38·38 per cent. alloy give nearly the same amount of nitrous acid in each case (representing about 80 per cent. of the possible amount), and practically no ammonia. The remaining 20 per cent., or thereabouts, consists mainly of nitric oxide. As the products in each of the five cases seem to be the same, and nearly in the same proportions, we should expect that the amounts of heat evolved would form a pretty

regular progression between copper and the above alloy, following closely the theoretical line. We see a fair approximation to this in the diagram, but there is a gradual divergence from the line, indicating a deficit of heat. The specimen containing 38.38 per cent. of copper, which is not far from the predominant alloy CuZn_2 , shows a loss of 32 calories. Baker's experiments show almost exactly the same amount of loss of heat, though at a somewhat different place in the series.

The only way in which, as far as I can see, this residual deficit can be explained on chemical grounds, is by supposing that the action of this alloy upon nitric acid produces a larger amount of nitric oxide than in the case of pure copper. Table I. gives some indication that this may be the case, because the amount of nitrous acid produced is rather smaller in the alloys than with the metal itself, indicating that there must be more of some other product, presumably nitric oxide. But, allowing full force to this argument, it cannot account for as much as 10 calories of the deficit. There is in any case a residual deficit as yet unaccounted for on chemical grounds, and which may be regarded as the amount of heat evolved in the formation of the alloy.

The action of zinc, or of the alloys rich in zinc, upon nitric acid is very different. There is less nitrous acid formed, while ammonia and nitrous oxide are produced in considerable quantities. The substitution of ammonia for nitrous acid will not make much thermal difference; but as the calories obtained by the formation of nitrous oxide are at least 175 more than with nitric oxide, and 83 more than with nitrous acid, there does not seem any difficulty in accounting for the excess shown between the observed and calculated values for pure zinc, or for the alloys containing more than 70 per cent. of this metal.

The work both of Dr. Galt and Mr. Baker has evidently been carried out with the greatest care; but, considering the uncertainty of the thermo-chemical data and the great physical interest attaching to the research, it would seem highly desirable that further experiments on the copper-zinc alloys should be made with solvents which give a chemical action far more simple than that produced by nitric acid.

In concluding, I desire to acknowledge the great assistance Mr. Hibbert has rendered me in this inquiry.

XX. *On the Velocity of Solidification and Viscosity of Supercooled Liquids.* By HAROLD A. WILSON, B.A. (Camb.), D.Sc. (Lond.), M.Sc. (Vict.), 1851 Exhibition Scholar, Allen Scholar, Cambridge University*.

IN the following paper an account is given of a series of experiments, the object of which was to obtain information on the influence of the viscosity of a supercooled liquid on its rate of solidification. When solidification is started in a supercooled liquid, rays of solid grow in the liquid with a definite velocity the relation of which to the initial supercooling has been determined † for a number of substances, *e. g.* phosphorus and benzophenone. In considering the nature of the observed relation between the velocity and the supercooling, it is important to take into account the production of heat which accompanies the solidification, and which must raise the temperature of the surface at which the solidification takes place; so that the observed relation may differ greatly from the relation between the velocity and the temperature of the solidifying surface.

In a previous paper "On Velocity of Solidification" ‡ I have shown that the general character of the relation observed between the velocity of solidification and the supercooling of the liquid can be explained in detail by supposing the solidification to be due to the difference between the internal pressures in the liquid and solid, and that the molecules at the surface of separation between the solid and liquid are urged from the liquid into the solid by this difference in the internal pressures. Using the method given by Van't Hoff for calculating the osmotic pressure of a salt in solution from the depression of the vapour-pressure, and making certain assumptions described in detail in the paper just referred to, the following formula for the velocity was obtained:—

$$v = \frac{F}{A\alpha} \cdot \frac{\theta_0 - \theta}{\theta_0},$$

where v is the velocity of solidification, F the latent heat of fusion of one gram of the solid, A the force required to give unit velocity to one gram of the liquid diffusing through itself, α the thickness of the layer of molecules at the sur-

* Communicated by the Author.

† Gernez, *Journ. de Phys.* [2] ii. p. 159. Friedländer & G. Tammann, *Zeitschr. f. Phys. Chem.* xxiii. p. 326, and xxiv. p. 152.

‡ Proc. Camb. Phil. Soc. vol. x. pt. 1.

face of separation of the liquid and solid in which the fall of pressure takes place, θ_0 the melting-point on the absolute scale, and θ the actual temperature at the surface of separation.

If we regard F and α as constants and A as being proportional to the viscosity of the liquid, we can write the above formula thus :

$$v = C \frac{s}{V},$$

where C is a constant, $s = \theta_0 - \theta$ the actual supercooling, and V is the viscosity of the liquid.

Since V increases as the temperature falls, v may attain a maximum value and then fall when s is increased.

The experiments described in this paper were undertaken with the object of testing the formula $v = C \frac{s}{V}$; and they show that the main features at any rate of the observed relation between the velocity and temperature can be deduced from the results for the viscosity by means of this formula. In fact, when the constant C is so chosen as to make the maximum value of $C \frac{s}{V}$ equal to the maximum value of the velocity, then the values of $C \frac{s}{V}$ agree fairly well with the observed values of the velocity.

To find the extent to which the temperature of the solidifying surface, or rather that of the tips of the growing rays of solid, is raised above the original temperature of the liquid, experiments were made in which a thermocouple was immersed in the liquid, and the change in its temperature observed as the boundary between the solid and liquid passed it. The substance first used was salol, which was chosen because it solidifies very slowly (maximum velocity about 4 millimetres per minute), so that the thermocouple has a chance of taking up the temperature of the surface of separation.

The salol was contained in a glass U-tube which was immersed in a water-bath at constant temperature, and the thermocouple was put down one of the limbs of the U-tube. The couple used was made from iron and nickel wires each 0.2 millim. in diameter, which were twisted together for about 2 millims. and kept apart by a thin capillary of glass round the iron wire. The iron and nickel wires dipped into small mercury cups kept in the same water-bath, from which

copper wires led to a very dead-beat mirror-galvanometer read by a telescope and scale. A deflexion of about 3 millim. divisions was obtained for a difference of temperature of one degree between the couple and the mercury cups, so that $\frac{1}{5}$ of a degree could be measured easily.

The salol was first melted by means of hot water, and then the U-tube was fixed in the bath and the couple put halfway down one limb. When the salol had taken up the temperature of the bath, solidification was started in the other limb, and the galvanometer observed as the surface of separation passed the couple. A millimetre-scale was fixed to the U-tube, so that the temperature of the couple and its position with respect to the surface of separation could be observed simultaneously. The following series of observations were obtained in one experiment:—

Diameter of tubing, 0.5 centim.

Temperature of bath, 31° 5 C.

Melting-point of the salol, 41° C.

Distance of the Couple from the Solid.	Temperature-Difference indicated by the Couple.
mms.	
5.6	0
5.1	0
4.7	0.2
2.8	0.9
2.3	1.2
1.4	1.5
1.0	1.9
0.5	2.4
0.4	3.0
0.0	3.3
-0.8	2.7
-2.0	0.5

The velocity of the boundary in this experiment was 1.3 millim. per minute. The maximum temperature was always indicated in the time during which the couple was partly in the solid and partly in the liquid. The twisted wires formed a couple about 0.4 millim. in diameter; so that in the experiment just described this time was about 18 seconds. The following table gives the maximum rise of temperature observed with the same tube at several temperatures.

Temperature of Bath.	Maximum Rise observed.	Temperature at which Solidification occurred.	Corresponding Velocity of Solidification.
			mms./min.
31.5	3.3	34.8	1.3
27.5	5.6	33.1	2.4
22.0	9.0	31.0	3.4
17.0	8.9	25.9	3.9
11.5	9.0	20.5	4.1

The following table gives the results obtained with a tube 0.2 centim. internal diameter.

Temperature of Bath.	Maximum Rise observed.	Temperature at which Solidification occurred.	Corresponding Velocity of Solidification.
			mms./min.
36.0	0.6	36.6	0.4
32.5	1.6	34.1	1.8
31.0	2.2	33.2	2.3
25.3	2.8	28.1	3.8
21.0	3.4	24.4	4.0
16.7	3.6	20.3	4.1
11.3	3.8	15.1	4.1

The last column in each of the above two tables contains the velocities of solidification in the same tubes obtained by interpolation from observations on the velocity at a number of temperatures. The velocity was determined by measuring the time taken by the boundary to pass between two marks on the tube at a known distance apart. The following results were obtained with the same two tubes:—

Tube 0.5 centim. in diameter.

Temperature of Bath.	Velocity of Solidification.
°	mms./min.
32.0	1.10
25.0	3.02
20.0	3.55
15.0	4.00

Tube 0.2 centim. in diameter.

Temperature of Bath.	Velocity of Solidification.
°	mms./min.
34.3	1.10
33.0	1.62
30.0	2.88
28.0	3.30
27.0	3.23
24.0	3.87
23.5	3.88
17.0	3.93
11.5	4.13

Fig. 1.—Velocity of Solidification of Salol.

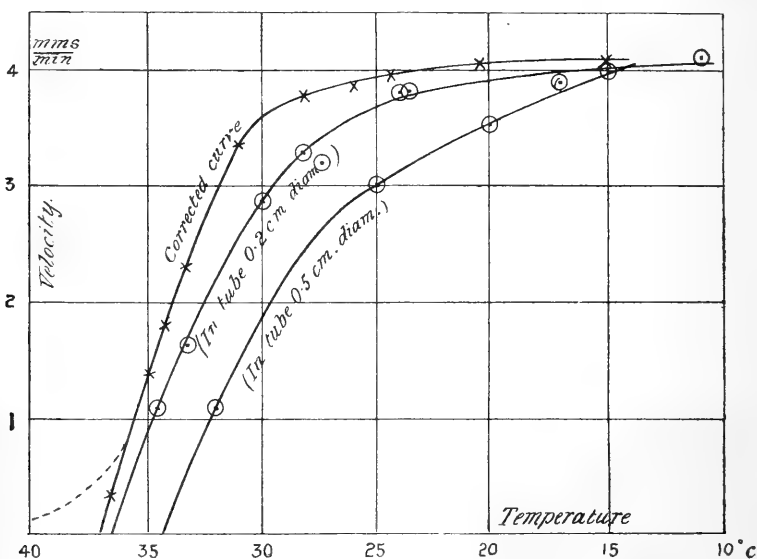

These results are shown graphically in fig. 1. It will be observed that the velocities are not the same at the same temperatures in the two tubes; but when the correction indicated by the thermocouple is applied, the two curves become approximately identical. The wider tube had thicker walls than the narrower one, which of course would render the escape of the heat developed more difficult in the wider tube, which accounts for the greater rise of temperature found in it.

The effect on the velocity of surrounding the tube by a

wider glass tube forming an air-jacket was tried. This was found to diminish the velocity considerably, as we should expect owing to the increased difficulty with which the heat developed could escape. Thus with the water-bath at 32° the velocity with the additional tube was $0.88 \frac{\text{mm.}}{\text{min.}}$, and without the additional tube it was $1.1 \frac{\text{mms.}}{\text{min.}}$.

To test the validity of the formula $v = C \frac{s}{\sqrt{v}}$, the viscosity of supercooled salol was measured at a number of temperatures. The apparatus was of the ordinary form, consisting of two small glass bulbs connected by a capillary and bent round into a U-shaped tube. The time required by the meniscus of the liquid to pass between two marks, one above and one below the upper bulb, was determined whilst the apparatus was fixed in a water-bath at a known constant temperature. The capacity of the upper bulb was about 2 cub. cent., and the time for water at 15° C. was 24.5 seconds.

The open ends of the U-tube were connected by india-rubber tubes to bulbs containing calcium chloride to prevent moisture getting to the liquid. When the liquid began to solidify, it was melted by putting the tube in hot water. The following table gives the results obtained for the viscosity of salol.

*Salol.*Melting-point, 41° C.Density 1.195 at 35° C.

Temperature.	Time.	Viscosity. (Water at $15^{\circ}=1$.)
	secs.	
42.0	149.3	7.27
35.9	196.5	9.57
29.0	278.5	13.57
25.0	350.0	17.05
19.5	519.2	25.29
15.0	649.0	31.60

These results are shown graphically in fig. 3.

The formula $v = C \frac{s}{\sqrt{v}}$ indicates that the velocity should increase proportionally to the supercooling when it is small. Now the relation observed between the velocity and super-

cooling usually shows a very small rate of increase of velocity when the supercooling is small. This is shown in fig. 1, where the velocity-curve produced cuts the axis of temperature at 37° , whilst the melting-point of the salol was about $41^{\circ}\cdot 0$. Still some indications of partial melting occurred at about 37° ; and it is very probable that if the substance were quite pure, then the very small rate of increase of the velocity near the melting-point would not occur. Tammann (*loc cit.*) has shown that purifying a substance always diminishes this region of small velocity; and consequently, for the purpose of testing the formula $v = C \frac{s}{V}$, I have measured the supercooling from the point ($37^{\circ}\cdot 0$) at which the velocity-curve shown in fig. 1 cuts the temperature-axis.

To get the value of C in the formula $v = C \frac{s}{V}$ the values of the velocity (v) and viscosity (V) were taken at 22° , at which temperature s is 15° ; hence $C = \frac{4\cdot 1 \times 21\cdot 0}{15} = 5\cdot 74$.

The following table shows the results obtained, using the formula $v = 5\cdot 74 \frac{s}{V}$ and values of V taken from the curve for the viscosity of salol.

Temp.	s .	V .	v $= 5\cdot 74 \frac{s}{V}$.	v . (Found.)
35°	2°	10·0	1·15	1·25
33	4	10·7	2·14	2·5
31	6	12·0	2·90	3·2
29	8	13·5	3·40	3·7
27	10	15·0	3·82	3·9
25	12	17·0	4·05	4·0
21	16	22·5	4·08	4·1
19	18	25·0	4·13	4·1
15	22	31·6	4·00	4·1

The agreement between the found and calculated values of v is sufficiently good. The independence of the velocity and the temperature from 15° to 25° thus appears to be due in this case to the viscosity being approximately proportional to the supercooling between these limits of temperature.

The formula $v = C \frac{s}{V}$ thus represents the variation of the

velocity with the temperature at which it takes place in a very satisfactory manner in the case of salol.

In the case of substances having greater velocities of solidification than salol, it is not easy to determine the rise in temperature during solidification. I have made measurements of the viscosity and velocity of solidification of supercooled salol, benzophenone, benzoic anhydride, and azobenzol, for which measurements of the velocity have also been made by Friedländer and Tammann (*loc. cit.*), and my results for the velocity do not differ much from those given by them. Benzoic anhydride has a maximum velocity of about $35 \frac{\text{mms.}}{\text{min.}}$; so that the thermocouple would only be in the boundary for 0.6 sec., which is probably not long enough to enable it to take up the temperature at the boundary.

Another difficulty was that the galvanometer available had rather a long period of swing, so that it could not be used for measuring so sudden a rise of temperature. An attempt was made to increase the time during which the couple was in the boundary, by moving it along with a velocity nearly equal to the velocity of the boundary; and an apparatus was made which automatically did this. Unfortunately, however, the motion of the couple in the liquid nearly always caused it to solidify, and the couple became fixed in the solid. I believe that this could be prevented by taking care not to allow the wires from the couple to carry any of the liquid into the cold air above the bath, and by heating the couple with the liquid for a long time; but I am not able at present to devote any more time to these experiments, and shall therefore simply use the results obtained to test the formula $v = C \frac{s}{\sqrt{V}}$ without correcting for the rise in temperature during the solidification.

The following Tables give the results obtained with benzoic anhydride. The velocity was measured between two marks 10 cms. apart on a tube 0.3 cm. in diameter. The apparatus already described was used for the viscosity determinations.

Benzoic anhydride.

Melting-point, 42° C.

Density at 38° C., 1.188.

Velocity of Solidification.		Viscosity. (Water at 15° = 1.)		
Temp.	Velocity.	Temp.	Time.	Viscosity.
	mms./min.		secs.	
38.0	18.8	39.7	287.5	13.97
35.0	29.1	34.0	370	17.84
30.6	33.6	33.3	382	18.57
26.5	35.2	27.3	513	24.92
24.75	34.9	20.65	757	36.79
18.75	34.9	18.5	880	42.77
		12.1	1384	67.25

Fig. 2.—Velocity of Solidification and Temperature.

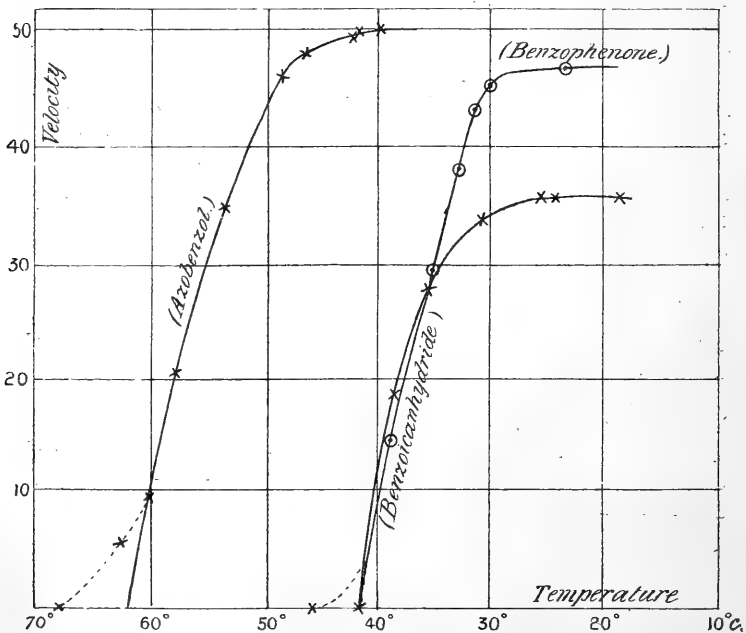

These results are shown in figs. 2 and 3. Calculating in the same way as before, we get $\bar{C} = 60$, which gives the following results:—

Temp.	s.	V.	$\frac{v}{(=C \frac{s}{V})}$	$\frac{v}{(Found.)}$
			mms./min.	mms./min.
38	4	15.0	16.2	18.0
34	8	17.7	27.2	30.5
30	12	22.0	32.8	34.0
26	16	27.0	35.6	35.0
22	20	34.0	35.3	35.0
18	24	43.1	33.8	35.0
12	30	67.5	26.7

Fig. 3.—Viscosity and Temperature.

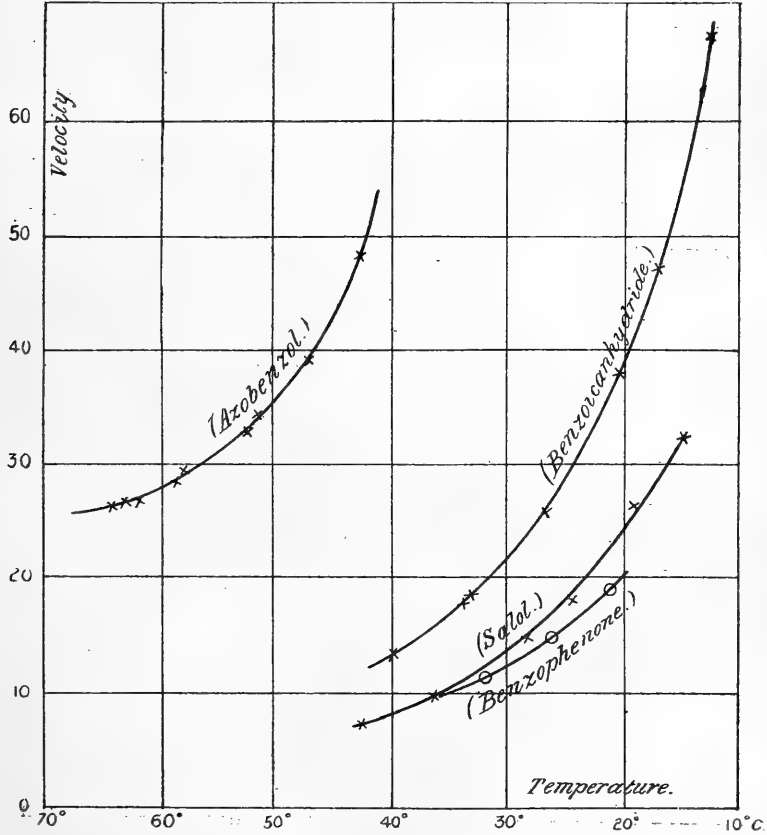

The agreement between the found and calculated value of v is about as good as it was with salol, although the

rise in temperature due to the solidification has not been allowed for. It may be that the rise in temperature is less when the velocity of solidification is greater; and so neglecting the rise may not make much difference. The calculated value of v at 18° C. is smaller than at 22° C., so that at 18° C. the supercooling is greater than that for which v is a maximum. Hence the temperature of the solidifying surface is probably* raised by the heat developed to the temperature at which v is a maximum; so that when the bath is below this temperature the actual temperature at which the solidification takes place remains constant, consequently observations on the velocity cannot really be made at any lower temperature unless the temperature is so low that the latent heat of solidification is not enough to raise the temperature up to that at which the velocity is a maximum. Hence the calculated values of the velocity will not agree with the uncorrected values found apparently below the temperature at which the velocity is a maximum except so long as the calculated velocity also remains practically constant at the maximum value.

The following Tables give the results obtained with benzophenone.

Benzophenone.

Melting-point, $46^{\circ}\cdot5$ C.

Density at 31° C., 1.099.

Velocity of Solidification.		Viscosity. (Water at $15^{\circ}=1$.)		
Temp.	Velocity.	Temp.	Time.	Viscosity.
	mms./min.	°	secs.	
38.3	15.0	32.93	241.0	10.80
34.7	31.9	27.10	319.5	14.33
33.0	37.8	21.9	410.5	18.41
32.0	43.0			
30.0	45.9			
24.0	46.4			

These results are shown graphically in figs. 2 and 3. Calculating in the same way as before, we get $C=44.1$, which gives the following results:—

* See paper "On Velocity of Solidification," *loc. cit.*

Temp.	s.	V.	$\frac{v.}{\left(=C \frac{s}{V}\right)}$	$\frac{v.}{\text{(Found.)}}$
38	4	9.0	19.6	15.0
34	8	10.4	33.8	34.0
32	10	11.1	39.8	43.0
30	12	12.4	42.7	45.9
28	14	13.6	45.5	46.0
26	16	15.1	46.7	46.4
24	18	16.9	47.0	46.4
22	20	19.3	45.6	46.4

The following are the results obtained with azobenzol, which are also shown graphically in figs. 2 and 3:—

Azobenzol.

Melting-point, 67° 5 C.

Density at 50° C., 1.038.

Velocity of Solidification.		Viscosity. (Water at 15° = 1.)		
Temp.	Velocity.	Temp.	Time.	Viscosity.
°	mms./min.	°	secs.	
62.0	57.1	65.1	60.2	2.56
59.7	88.2	63.7	61.5	2.61
57.1	207.0	61.9	62.1	2.64
53.4	345	58.5	65.5	2.78
48.8	465	57.8	66.6	2.83
45.5	484	57.5	68.0	2.89
42.0	492	52.8	75.0	3.19
41.4	500	51.6	79.0	3.36
39.5	500	47.0	92.1	3.92
.....	43.1	111.0	4.70

Calculating in the same way as before, we get C=125, which gives the following results:—

Temp.	s.	V.	$\frac{v.}{\left(=C \frac{s}{V}\right)}$	$\frac{v.}{\text{(Found.)}}$
60	2	2.72	92	90
58	4	2.82	177	170
56	6	2.94	255	250
54	8	3.10	322	320
52	10	3.30	379	390
50	12	3.52	426	445
48	14	3.80	460	470
46	16	4.13	485	483
44	18	4.52	498	490
42	20	5.00	500	495

It thus appears that the formula $v = C \frac{s}{V}$ represents the variation of v with s sufficiently well to justify the conclusion that the velocity is largely determined by the viscosity in the way indicated by the formula.

Two main causes, to which I have already referred, probably account for the discrepancies between the values of $C \frac{s}{V}$ and the velocities observed. The first cause, namely, the rise of temperature due to the production of heat accompanying the solidification, does not affect the comparison of the calculated and observed velocities in the case of salol, for in this case it was measured and allowed for; but with the other three bodies investigated the temperatures at which the velocities are measured are too low, owing to this effect. If the correction for this effect were made, it would probably raise the point at which the straight part of the velocity-curve when produced cuts the temperature-axis, so that measuring s from this point probably partly eliminates the error due to this cause.

The other cause, namely, the presence of impurities in the substance, probably accounts for the small velocities observed near the melting-point, which I have not attempted to represent by the formula, and which occur with three out of the four substances investigated. When impurities are present, solidification near the melting-point is more correctly described as cry-tallization from a strong solution, and must evidently depend on the rates of diffusion of the substance and impurities in each other, for as the pure substance separates out the impurities collect round it; and so it is easy to see that the rate of solidification may be greatly affected by small amounts of impurities quite insufficient to have a corresponding influence on the viscosity of the substance. That purifying the material is able to diminish greatly the range of temperature over which the velocity increases very slowly with the supercooling has been shown by Friedländer and Tammann (*loc. cit.*), so that it seems reasonable to suppose that with pure substances the velocity would be at first proportional to the supercooling, as the formula $C \frac{s}{V}$ indicates, and as is approximately the case with the benzoic anhydride I used.

I think, therefore, that the above results render it probable that the velocity of solidification of a pure substance varies directly as the actual supercooling at which the solidification occurs, and inversely as the viscosity of the liquid.

Wilmerdorf, Berlin,
Feb. 15, 1900.

XXI. *Theory of the Constant-volume Gas-thermometer.*

By J. ROSE-INNES, M.A., B.Sc.*

THE importance which the constant-volume gas-thermometer has assumed in practical physics justifies an attempt to improve the theory of the instrument.

Manipulation of the Fundamental Differential Equation.

In the customary theory of the constant-volume thermometer we start with the differential equation

$$t \left(\frac{dv}{dt} \right)_p - v = JK \frac{\partial t}{\partial p},$$

and after dividing by t^2 we integrate with respect to t . The integration is of necessity along an isopiestic owing to the occurrence of the term $\left(\frac{dv}{dt} \right)_p$. The result of integration involves an arbitrary function of p , and in order to evaluate this function we imagine the integration carried to infinite values of v and t along the isopiestic. This plan has been adopted by Lord Kelvin (Reprinted Papers, vol. i. pp. 429-430) and by subsequent investigators; it is also employed in the paper published by me "On Lord Kelvin's Absolute Method of Graduating a Thermometer" (Phil. Mag. xlv. pp. 232-233).

The weak point of this method is that we have to assume that $JK \frac{\partial t}{\partial p}$ is known at all temperatures, and that an empirical formula, which happens to fit the Joule-Thomson results fairly well throughout the small range of their experiments, necessarily holds at any temperature however high. An extrapolation to infinity of the above kind must inevitably introduce some uncertainty into the results obtained. But it is possible to abolish this extrapolation by properly transforming the differential equation before integration.

We start from the fundamental equation

$$t \left(\frac{dv}{dt} \right)_p - v = JK \frac{\partial t}{\partial p}.$$

In order to get rid of the isopiestic differential coefficient we may employ the relation

$$\left(\frac{dp}{dv} \right)_t \left(\frac{dv}{dt} \right)_p \left(\frac{dt}{dp} \right)_v = -1.$$

(See Baynes's Thermodynamics, p. 23.)

* Communicated by the Author.

We may write this

$$\left(\frac{dv}{dt}\right)_p = -\left(\frac{dp}{dt}\right)_v \left(\frac{dv}{dp}\right)_t.$$

Substituting this value in the differential equation we obtain

$$-t \left(\frac{dp}{dt}\right)_v \left(\frac{dv}{dp}\right)_t - v = JK \frac{\partial t}{\partial p}.$$

Multiply by $-\left(\frac{dp}{dv}\right)_t$

$$t \left(\frac{dp}{dt}\right)_v + v \left(\frac{dp}{dv}\right)_t = -JK \frac{\partial t}{\partial p} \left(\frac{dp}{dv}\right)_t.$$

Again, if we put ψ for the product pv we have

$$v \left(\frac{dp}{dv}\right)_t = -p + \left(\frac{d\psi}{dv}\right)_t.$$

Hence

$$t \left(\frac{dp}{dt}\right)_v - p + \left(\frac{d\psi}{dv}\right)_t = -JK \frac{\partial t}{\partial p} \left(\frac{dp}{dv}\right)_t.$$

The quantity $\left(\frac{d\psi}{dv}\right)_t$ may conveniently be removed to the other side of the equation; we thus obtain

$$t \left(\frac{dp}{dt}\right)_v - p = -JK \frac{\partial t}{\partial p} \left(\frac{dp}{dv}\right)_t - \left(\frac{d\psi}{dv}\right)_t.$$

We also have

$$\left(\frac{d\psi}{dv}\right)_t = \left(\frac{d\psi}{dp}\right)_t \left(\frac{dp}{dv}\right)_t,$$

and employing this value the differential equation becomes

$$t \left(\frac{dp}{dt}\right)_v - p = - \left\{ JK \frac{\partial t}{\partial p} + \left(\frac{d\psi}{dp}\right)_t \right\} \left(\frac{dp}{dv}\right)_t.$$

If by any method we are enabled to express the right-hand side of this equation in terms of v and t , the integral of the equation will give us the connexion between p and t at constant volume without an extrapolation to infinity. In order that t may be a linear function of p when v is kept constant, the necessary and sufficient condition is that the right-hand side of the equation should be a function of v only.

The quantities $JK \frac{\partial t}{\partial p}$ and $\left(\frac{d\psi}{dp}\right)_t$ are both measurable for several substances; in the cases of hydrogen, nitrogen, and

air they are both found to be very small. Consequently their sum $JK \frac{\partial t}{\partial p} + \left(\frac{d\psi}{dp}\right)_t$ is also a small quantity; and if we use an approximate equation in finding the value of $\left(\frac{dp}{dv}\right)_t$ we shall only be introducing errors corresponding to squares of small quantities.

Now if $pv = Rt$
we have

$$\left(\frac{dp}{dv}\right)_t = -\frac{Rt}{v^2}.$$

Employing this approximate value for $\left(\frac{dp}{dv}\right)_t$ we obtain

$$t\left(\frac{dp}{dt}\right)_v - p = \left\{ JK \frac{\partial t}{\partial p} + \left(\frac{d\psi}{dp}\right)_t \right\} \frac{Rt}{v^2}.$$

It is further shown by experiment that for hydrogen, nitrogen, and air, the quantities

$$JK \frac{\partial t}{\partial p} \quad \text{and} \quad \left(\frac{d\psi}{dp}\right)_t$$

are nearly independent of the pressure, and depend on the temperature only. Consequently to our present degree of approximation, the quantity

$$JK \frac{\partial t}{\partial p} + \left(\frac{d\psi}{dp}\right)_t$$

may be taken as a function of the temperature only; and in order that the constant-volume thermometer may give readings in accordance with the thermodynamic scale we must have the values of

$$JK \frac{\partial t}{\partial p} + \left(\frac{d\psi}{dp}\right)_t$$

varying inversely as the absolute temperature.

The Absolute Value of the Freezing-point of Water.

We may apply the formula obtained in the last section to the determination of the absolute value of the freezing-point of water. Estimates of the value of this important physical constant have already been given by Lord Kelvin (Reprinted Papers, vol. iii. p. 177), but his figures are based on the results of experiments with the constant-pressure gas-thermometer.

A careful determination of the increase of pressure of hydrogen at constant volume from the freezing-point to the boiling-point has recently been made by M. Chappuis (*Travaux et Mémoires du Bureau International*, tome vi. p. 108 ; see also Everett, C. G. S. System of Units, p. 115). The pressure at the freezing-point was 1 metre of mercury, and the increase of pressure was $\cdot 366254$ of a metre of mercury. If we could treat hydrogen as a perfect gas we should therefore obtain $\frac{100}{\cdot 366254}$ or $273^{\circ}034$ as the absolute value of the freezing-point.

But it is of course necessary to inquire how far we need a correction owing to the deviation of hydrogen from the laws of a perfect gas ; for this purpose we take the equation

$$t \left(\frac{dp}{dt} \right)_v - p = -JK \frac{\partial t}{\partial p} \left(\frac{dp}{dv} \right) - \left(\frac{d\psi}{dv} \right)_t.$$

Divide by t^2 and we have

$$\frac{d}{dt} \left(\frac{p}{t} \right) = -JK \frac{\partial t}{\partial p} \left(\frac{dp}{dv} \right)_t \frac{1}{t^2} - \left(\frac{d\psi}{dv} \right)_t \frac{1}{t^2}.$$

Let the suffix 0 refer to the freezing-point, the suffix 1 to the boiling-point, and integrate the above equation with respect to t between the limits t_0 and t_1 . We obtain

$$\begin{aligned} \frac{p_1}{t_1} - \frac{p_0}{t_0} &= - \int_{t_0}^{t_1} JK \frac{\partial t}{\partial p} \left(\frac{dp}{dv} \right)_t \frac{dt}{t^2} - \int_{t_0}^{t_1} \left(\frac{d\psi}{dv} \right)_t \frac{dt}{t^2} \\ &= M \left(\frac{1}{t_1} - \frac{1}{t_0} \right) + N \left(\frac{1}{t_1} - \frac{1}{t_0} \right), \end{aligned}$$

where M is some mean value of $JK \frac{\partial t}{\partial p} \left(\frac{dp}{dv} \right)_t$ and N is some mean value of $\left(\frac{d\psi}{dv} \right)_t$. Hence

$$\frac{p_1 - M - N}{t_1} = \frac{p_0 - M - N}{t_0} = \frac{p_1 - p_0}{t_1 - t_0}$$

so that

$$\begin{aligned} t_0 &= \frac{p_0 - M - N}{p_1 - p_0} (t_1 - t_0) \\ &= \frac{p_0}{p_1 - p_0} (t_1 - t_0) - \frac{M + N}{p_1 - p_0} (t_1 - t_0). \end{aligned}$$

The expression $\frac{p_0}{p_1 - p_0} (t_1 - t_0)$ gives us the value of t_0 when

we treat the substance as a perfect gas; in the case of hydrogen at an initial pressure of 1 metre of mercury we have already seen that its numerical value is 273·034. The

term $-\frac{M+N}{p_1-p_0}(t_1-t_0)$ gives us the thermodynamic correction necessary on account of the deviation of the behaviour of the substance from the laws of a perfect gas; it can be calculated when p_1 , p_0 , M , and N are known.

In order to discover the values of the mean quantities M and N accurately, we require to know in what way the two quantities

$$JK \frac{\partial t}{\partial p} \left(\frac{dp}{dv} \right)_t \text{ and } \left(\frac{d\psi}{dv} \right)_t$$

respectively vary with the temperature; such knowledge we do not at present possess. It is certain, however, that M must be less than the largest value of

$$JK \frac{\partial t}{\partial p} \left(\frac{dp}{dv} \right)_t$$

which occurs between t_0 and t_1 , and similarly N must be less than the largest value of $\left(\frac{d\psi}{dv} \right)_t$ which occurs between t_0 and t_1 . We are thereby enabled to calculate a superior limit to

each of the corrections corresponding to M and N respectively; and in the case of hydrogen we find that these corrections must be very small—so small that we may safely employ some rough method of finding the mean in order to reach the values of M and N . The errors introduced by taking an approximate mean instead of the true mean would not exceed the uncertainty involved in the value of

$\frac{p_0}{p_1-p_0}(t_1-t_0)$ owing to the ordinary errors of experiment.

For the purpose of calculating M we must employ the measurements, made by Joule and Kelvin, of the heating-effect which occurs when hydrogen is passed through a porous plug. The heating-effect amounted, at temperatures from 4° C. to 5° C., to 0°·100 C. per 100 inches of mercury; and at temperatures from 89° C. to 93° C. it amounted to 0°·155 C. per 100 inches of mercury (Reprinted Papers, vol. iii. p. 175). If the heating-effect had been constant and equal to the smaller of the two values quoted above, the value of M would have been ·000505 of a metre of mercury; if the heating-effect had been constant and equal to the larger of the two values, then M would have been ·001025 of a metre

of mercury. The value of M may be fairly taken as $\cdot 000765$, the arithmetic mean between $\cdot 000505$ and $\cdot 001025$.

For the purpose of calculating N we may employ the results of M. Amagat, who examined the relation of the pressure to the volume of various gases when the temperature is kept constant. In the case of hydrogen, the range of temperature of his experiments was from $17^{\circ}\cdot 7$ C. to $100^{\circ}\cdot 1$ C. He plotted the values of pv against p , and found that within the limits of temperature of his experiments the isothermals could be treated as a set of parallel straight lines. It is not possible to accept this conclusion as absolutely correct. For if the isothermals at all temperatures were taken as represented by a set of parallel straight lines, there would be no critical state, liquefaction would be impossible; and we should never have pv decreasing as p increases. We may therefore infer that M. Amagat's law is only an approximation, and that at higher temperatures pv really increases rather more rapidly with p than at lower temperatures. M. Amagat considers that the value of $\left(\frac{d\psi}{dp}\right)_t$ is $\cdot 00078$ when the unit of volume is the volume occupied by the gas under standard conditions. It is perhaps safest to attach this number to the isothermal of 50° C.; we then obtain for $\left(\frac{d\psi}{dv}\right)_t$ at 50° C. the value of $-\cdot 001215$ of a metre of mercury, which pressure may also be taken as equal to N .

The resulting value of $M+N$ is $-\cdot 000450$ of a metre of mercury; and the corresponding correction for t_0 is $0^{\circ}\cdot 123$. This yields as the final value of t_0 the figure $273^{\circ}\cdot 157$, which is very close to the estimate derived by Lord Kelvin from the constant-pressure air-thermometer (Reprinted Papers, vol. iii. p. 177).

The Characteristic Equation of a nearly Perfect Gas.

We have already seen that for substances like hydrogen and air the equation

$$t\left(\frac{dp}{dt}\right)_v - p = -JK \frac{\partial t}{\partial p} \left(\frac{dp}{dv}\right)_t - \left(\frac{d\psi}{dv}\right)_t$$

reduces to

$$t\left(\frac{dp}{dt}\right)_v - p = \left\{ JK \frac{\partial t}{\partial p} + \left(\frac{d\psi}{dv}\right)_t \right\} \frac{Rt}{v^2};$$

and we remarked that the condition necessary and sufficient to make t a linear function of p when v is kept constant is

that the quantity in curly brackets should vary inversely as the absolute temperature. An examination of the experimental results obtained with such gases shows us that $\text{JK} \frac{\partial t}{\partial p} + \left(\frac{d\psi}{dp}\right)_t$ is a positive quantity which decreases as the temperature increases; and it is quite consistent with the experimental evidence to assume that $\text{JK} \frac{\partial t}{\partial p} + \left(\frac{d\psi}{dp}\right)_t$ actually varies as the inverse temperature, making due allowance for the unavoidable errors of experiment. At the same time the measurements that have been made do not enable us to assert that the proposed law has been proved; it is conceivable that $\text{JK} \frac{\partial t}{\partial p} + \left(\frac{d\psi}{dp}\right)_t$ decreases rather more rapidly than the inverse temperature.

The simplicity of the proposed law, and its close approximation to the truth, render it interesting to examine what further deductions can be made therefrom. We start with the equation

$$t \left(\frac{dp}{dt}\right)_v - p = -\text{JK} \frac{\partial t}{\partial p} \left(\frac{dp}{dv}\right)_t - \left(\frac{d\psi}{dv}\right)_t,$$

and then suppose that the right-hand side of the equation is found by experiment to be equal to $\frac{\lambda}{v^2}$, where λ is a constant.

We thus have

$$t \left(\frac{dp}{dt}\right)_v - p = \frac{\lambda}{v^2}.$$

Integrating this we obtain

$$p = f(v)t - \frac{\lambda}{v^2},$$

where $f(v)$ is a function of the volume only. Multiply by v , and then differentiate with regard to v keeping t constant; we get

$$\left(\frac{d\psi}{dv}\right)_t = \{f(v) + vf'(v)\}t + \frac{\lambda}{v^2}.$$

Also since

$$-\left(\frac{d\psi}{dv}\right)_t - \text{JK} \frac{\partial t}{\partial p} \left(\frac{dp}{dv}\right)_t = \frac{\lambda}{v^2},$$

we may write

$$2 \left(\frac{d\psi}{dv}\right)_t + \text{JK} \frac{\partial t}{\partial v} \left(\frac{dp}{dv}\right)_t = \{f(v) + vf'(v)\}t.$$

Since

$$\begin{aligned} 2 \left(\frac{d\psi}{dv} \right) + JK \frac{\partial t}{\partial p} \left(\frac{dp}{dv} \right)_t &= \left\{ 2 \left(\frac{d\psi}{dp} \right)_t + JK \frac{\partial t}{\partial p} \right\} \left(\frac{dp}{dv} \right)_t \\ &= \left\{ 2 \left(\frac{d\psi}{dp} \right)_t + JK \frac{\partial t}{\partial p} \right\} \left\{ f'(v)t + \frac{2\lambda}{v^3} \right\}, \end{aligned}$$

we must also have

$$\left\{ 2 \left(\frac{d\psi}{dp} \right)_t + JK \frac{\partial t}{\partial p} \right\} \left\{ f'(v)t + \frac{2\lambda}{v^3} \right\} = \{ f(v) + vf'(v) \} t.$$

This equation is exact; but if $\left(\frac{d\psi}{dp} \right)_t$ and $JK \frac{\partial t}{\partial p}$ are small quantities, and if we are content to neglect squares of small quantities, we may put approximately

$$\left\{ 2 \left(\frac{d\psi}{dp} \right)_t + JK \frac{\partial t}{\partial p} \right\} f'(v)t = \{ f(v) + vf'(v) \} t;$$

so that

$$2 \left(\frac{d\psi}{dp} \right)_t + JK \frac{\partial t}{\partial p} = \frac{f(v)}{f'(v)} + v.$$

The expression $\frac{f(v)}{f'(v)} + v$ is a function of v only, and as we know independently $2 \left(\frac{d\psi}{dp} \right)_t + JK \frac{\partial t}{\partial p}$ is a function of t only we must have $\frac{f(v)}{f'(v)} + v$ a constant, say B . Then from the differential equation

$$\frac{f(v)}{f'(v)} + v = B,$$

we obtain by integration

$$f(v) = \frac{R}{v - B},$$

where R is a constant. The constant R has been introduced by an integration, and is therefore arbitrary as far as the differential equation is concerned; it is fixed, however, by the consideration that the interval of temperature between the freezing-point and the boiling-point has an arbitrarily chosen value. Since

$$p = f(v)t - \frac{\lambda}{v^2},$$

and

$$f(v) = \frac{R}{v - B},$$

we must have

$$p = \frac{Rt}{v - B} - \frac{\lambda}{v^2}.$$

The Difference between Joule's Method and Lord Kelvin's Method of Testing Mayer's Hypothesis.

The formula obtained in the first section may also be usefully employed to exhibit the precise connexion between Joule's method and Lord Kelvin's method of testing Mayer's hypothesis. The language of most text-books on this subject is far from satisfactory; it is often implied that Lord Kelvin's method is the same as Joule's except as regards delicacy; and the relation between the two methods is never given rigorously.

Mayer's hypothesis consisted in assuming that for common air and some other gases the amount of heat given out by the gas during an isothermal compression was exactly equal to the work done. Evidently, if this is so, there can be no change of energy during an isothermal compression; and we have the energy remaining constant whenever the temperature remains constant. This hypothesis was put to the test of experiment by Joule, and roughly verified. Joule's apparatus consisting of two large copper vessels is well known; and it is evident that his experiment tests Mayer's hypothesis directly. For if the temperature remains unaltered, as Joule found to be the case, the gas has received no heat and done no work, so that it has not gained any energy from surrounding objects; hence the constancy of temperature is accompanied by the constancy of energy.

The thermodynamics of Joule's experiment are easily given; we have in all cases

$$dE = kdt + \left\{ t \left(\frac{dp}{dt} \right)_v - p \right\} dv.$$

(See Baynes's 'Thermodynamics,' p. 88.) Joule's result shows that dE and dt are zero simultaneously, while dv does not vanish; hence we obtain

$$t \left(\frac{dp}{dt} \right)_v - p = 0.$$

The quantity $t\left(\frac{dp}{dt}\right)_v - p$ is therefore proved to be zero in so far as we can treat Joule's result as free from experimental error.

The great flaw in Joule's method is that it is not sufficiently delicate, and a sensible deviation from Mayer's hypothesis might occur without being detected. Lord Kelvin considerably improved Joule's apparatus as regards delicacy, but he also changed the theory of the experiment. The equation given in his writings as applying to his form of the experiment is

$$t\left(\frac{dv}{dt}\right)_p - v = JK \frac{\partial t}{\partial p};$$

so that when no change of temperature is observed we should have

$$t\left(\frac{dv}{dt}\right)_p - v = 0.$$

This condition is not necessarily the same as

$$t\left(\frac{dp}{dt}\right)_v - p = 0.$$

The precise manner in which the fall of temperature occurring in Lord Kelvin's form of the experiment may be made to test Mayer's hypothesis, is easily deduced from the formula obtained in the first section. Since

$$t\left(\frac{dp}{dt}\right)_v - p = - \left\{ JK \frac{\partial t}{\partial p} + \left(\frac{d\psi}{dp}\right)_t \right\} \left(\frac{dp}{dv}\right)_t,$$

we see that for Mayer's hypothesis to be true it is necessary and sufficient that

$$JK \frac{\partial t}{\partial p} + \left(\frac{d\psi}{dp}\right)_t = 0, \quad \text{or} \quad \partial t = - \frac{1}{JK} \left(\frac{d\psi}{dp}\right)_t \partial p.$$

Boyle's law is not rigorously fulfilled by any actual substance; hence we see that Mayer's hypothesis would be actually disproved by finding no change of temperature in the gas which had come through the porous plug.

XXII. *Torsion-Structure in the Alps.*

By JOHN BUCHANAN, B.Sc.*

IN an article with the above title ('Nature,' Sept. 7, 1899), Dr. Maria M. Ogilvie has given an outline of some of the results to which her observations in the field have led her.

I have here attempted to examine the application of some of the ideas there set forth to the case of a plastic, or quasi-plastic sheet. Let us imagine such a sheet to be subjected to forces of compression parallel to its surface. For our present purpose we may treat the sheet as incompressible. The resulting deformation of the sheet will be a series of corrugations, each corrugation consisting of an arch and a trough. The axes of these corrugations will on the average be, at each point, perpendicular to the direction of the force at that point. What will be the result if the sheet be now acted on by another set of compressive forces again parallel to the surface, but in a different direction from the first set?

Evidently, this second set of forces would *tend* to give rise to a new series of corrugations, which in turn would tend to have their axes everywhere at right angles to the direction of these forces. The actual result obtained at any point will be that due to the combination of the displacements which each set of forces would separately produce, the combination being effected by the parallelogram rule.

We will now proceed to consider the result of superposing a regular series of corrugations on another regular series, the two series being combined according to the method just indicated. In order to show the bearings of the method, two comparatively simple cases are here dealt with.

Case 1.—Let us assume the original corrugations of the sheet to be parallel to one another, and equally spaced, with their axes lying say east and west. Let now the second system of compressive forces act inwards towards a centre, so that, if alone, they will be assumed to give rise to a series of equally spaced concentric circular corrugations. The resultant curves are what Dr. M. M. Ogilvie has called "torsion-curves." Those figured in fig. 1 are confocal parabolas; the focus is the centre of the circular corrugations. So long, however, as the spacings are regular in the two sets of corrugations, the torsion-curves in case 1 are always confocal conics. Fig. 1 shows also how it is possible for the superposed system to cross the original corrugations at all angles from 0° to 90° .

In the more general case where the spacing of the circles and of the parallel lines is irregular, it would appear that each

* Communicated by the Author.

portion of the torsion-curves would be part of a conic whose focus is the centre of the concentric corrugations.

Fig. 1.

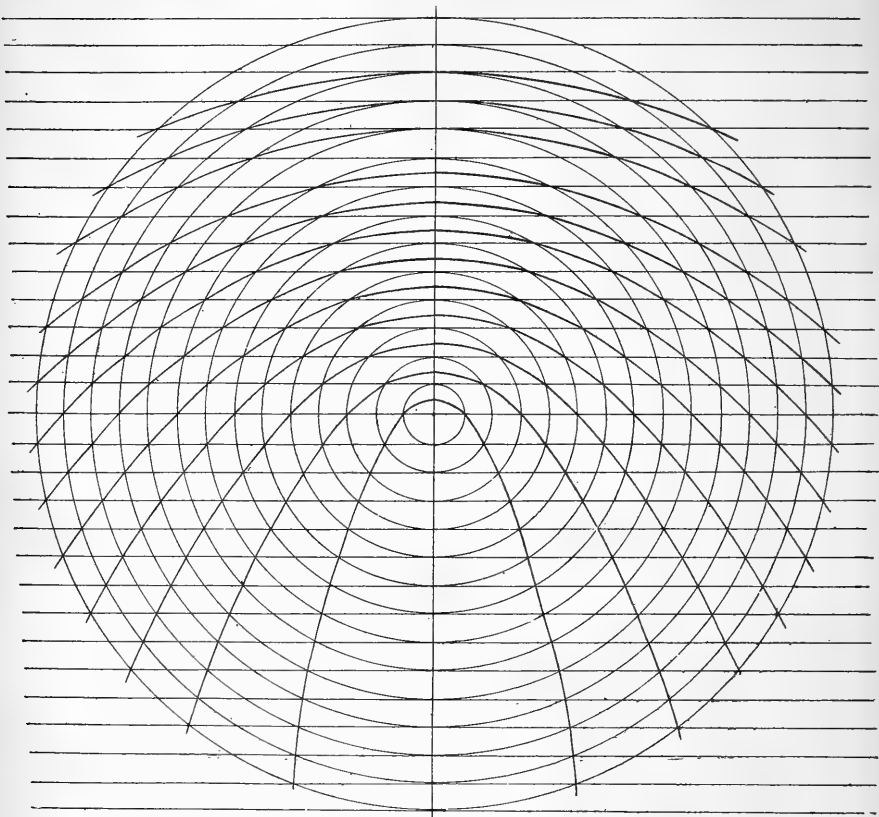

The general resemblance between the curves in fig. 1 and the torsion-curves drawn by Dr. M. M. Ogilvie for the Peri-Adriatic area of subsidence is evident (*Quart. Journ. Geol. Soc.* Aug. 1899, p. 630).

It may be pointed out also that since an area of subsidence, such a trough as the Adriatic for instance, is an area of weakness, the contraction of the earth's crust due to secular cooling would tend to move the torsion-curves more and more closely towards this region as time goes on. The average direction of motion at each point will be the direction of the force of compression at that point. The torsion-curves will on the average arrange themselves at right angles to these forces of compression. Now, the curves which are orthogonal to a system of confocal conics are themselves conics confocal with that system. Hence, if the torsion-curves at any time

assume the form of confocal conics round an area of subsidence, they tend to keep that form.

Case 2.—Fig. 2 shows the result of the superposition of a regularly-spaced system of radial corrugations on a regularly-spaced parallel system.

Fig. 2.

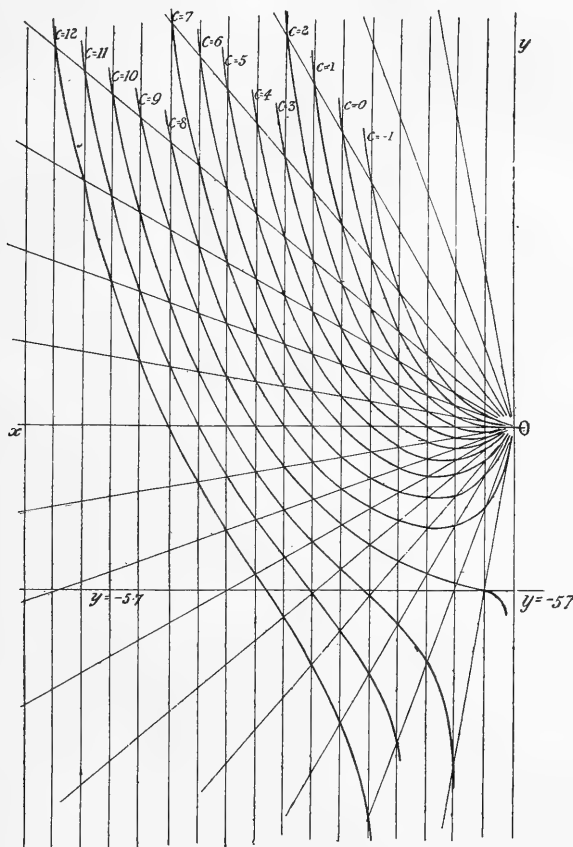

The resemblance of these curves to the spiral, or "whirl-shaped" arrangement of the various Alps is undoubtedly very suggestive. Here also, as in case 1, the superposed system crosses the original system at all angles from 0° to 90° .

In order not to confuse the figure I have shown only the positive branches of the curves.

As is shown in the appendix, the radial system of corrugations would require the forces, to which it would be due, to have a direction at right angles to the radii, and of magnitude inversely as the distance from the centre,

APPENDIX.

(a) The curves shown in fig. 2 have some interesting properties. Those figured are drawn so that the angle between two consecutive radii is 10° ($= \frac{\pi}{18}$).

It is easy to see that the equation to the system can be written

$$y = x \tan \frac{\pi}{18} (x - c) \quad \dots \dots \dots (1)$$

where c is a constant for each curve, but varies for different curves: its value is marked on each curve shown.

(b) If we assume that the curves are normal at each point to the resultant force at that point, then if X and Y represent the component forces, we can write

$$\frac{dy}{dx} = - \frac{X}{Y} \quad \dots \dots \dots (2)$$

From (1) we have

$$\begin{aligned} \frac{dy}{dx} &= \tan \frac{\pi}{18} (x - c) + x \times \frac{\pi}{18} \cdot \left(1 + \tan^2 \frac{\pi}{18} (x - c) \right) \\ &= \frac{y}{x} + \frac{\pi}{18} \frac{x^2 + y^2}{x} \\ &= \frac{\frac{y}{r^2} + \frac{\pi}{18}}{\frac{x}{r^2}} \end{aligned}$$

where $r^2 = x^2 + y^2$.

Thus, by means of (2), we may put

$$X = -K \frac{y}{r^2} - K \cdot \frac{\pi}{18},$$

$$Y = K \cdot \frac{x}{r^2},$$

where K is an arbitrary constant.

The displacing forces can therefore be considered as

(α) A constant force $= -K \frac{\pi}{18}$ acting parallel to the axis of x .

(β) A force $= \frac{K}{r}$ perpendicular to the radius vector. It will be noted that X and Y fulfil the "equation of continuity" for the case of forces in a plane, namely,

$$\frac{dX}{dx} + \frac{dY}{dy} = 0.$$

(c) Further, the curves represented by (1) have their

points of inflexion lying in a line

$$y = -\frac{18}{\pi} \\ = -5.7$$

parallel to the axis of x : this line is shown in fig. 2.

(d) The equation to a system of curves orthogonal to the curves represented by (1) is

$$x^2 + y^2 = e^{\frac{2\pi}{18}(k'-y)}$$

where k' is an arbitrary constant.

The direction of the resultant force at any point, which which would give rise to the curves represented by (1), is a tangent to the orthogonal curve which passes through that point.

56 St. Swithin Street, Aberdeen.

XXIII. *Proceedings of Learned Societies.*

GEOLOGICAL SOCIETY.

[Continued from p. 180.]

March 21st, 1900.—H. W. Monckton, Esq., F.R.S., Vice-President, in the Chair.

THE following communications were read:—

1. 'On a Bird from the Stonesfield Slate. By Prof. H. G. Seeley, F.R.S., F.L.S., V.P.G.S.

2. 'The Lower Ludlow Formation and its Graptolite-Fauna.' By Miss Ethel M. R. Wood.

After dealing with the literature of the stratigraphical and palæontological sides of the subject, the author passes to a full consideration of the sequence and character of the Ludlow Rocks in the following localities:—The Ludlow district, the Builth district, the Long Mountain; and gives a briefer account of those of the Dee Valley, the Lake district, Southern Scotland, Dudley, and the Abberley Hills. While the Wenlock Shales are characterized by *Cyrtograptus* and by the *Flemingii*-type of *Monograptus*, in the Lower Ludlow Shales the *colonus*- and spinose forms of *Monograptus* such as *M. chimæra* are abundant. The line between Lower and Upper Ludlow is drawn at the top of the Aymestry Limestone. The Lower Ludlow Rocks are divided into five graptolitic zones, which are not constant in character or thickness in the different areas. The distribution of the zones is given in the annexed table (p. 266). Two of the zone-graptolites are new species, described in the latter part of the paper.

In the Ludlow area the two lowest zones are rich in graptolites, but shade into each other, and are therefore less clearly defined than the higher zones, which each contain practically only one species and are lithologically distinct. In the Builth area the variation in the zones in different parts may be due to the conditions of depth and current under which the graptolites have been deposited, or to the overlap of higher beds on lower, as has been shown to be the case with the Wenlock and Old Red Sandstone rocks. In the Long Mountain syncline, *M. scanicus* is practically absent, and the

TABLE SHOWING THE GEOGRAPHICAL VARIATION IN LITHOLOGY AND THICKNESS OF THE ZONES OF THE LOWER LUDLOW ROCKS.

ZONES.	BUILTH DISTRICT.		LONG MOUNTAIN DISTRICT.	DEE VALLEY.	LAKE DISTRICT.
	EASTERN AREA.	SOUTH-WESTERN AREA.			
Zone of <i>Monograptus leintwardinensis</i> .	Aymestry Limestone (275 feet). Calcareous laminated flags, passing down into light - brown flaggy mudstones (210 feet).	Thin calcareous bands and micaceous laminated flags, passing gradually into Light flaggy mudstones and darker calcareous flags (400 to 500 feet).	Micaceous flags passing into Light flaggy mudstones. (900 feet?)	<i>Leintwardinensis</i> -Flags.	Bannisdale Slates: [Upper parts calcareous.] (5000 feet.)
	Light flaggy mudstones (220 feet).	Light flaggy mudstones and darker calcareous flags (400 to 500 feet).		Upper Gritty Beds.	
Zone of <i>M. tumescens</i> , sp. nov.	Light flaggy mudstones and shales (100 feet).	Greyish - brown shales, with some flaggy mudstones (250 feet).		[No fossils.]	Coniston Grits.
Zone of <i>M. scanicus</i> .	More thinly bedded mudstones and shales (120 feet).	Greyish - brown shales, with thin calcareous bands.	Greyish - brown thinly - bedded shales (350 feet).	Nantglyn Flags.	Upper Coldwell Flags.
Zone of <i>M. Nilssonii</i> .	Thinly bedded shales. No graptolites. (130 feet.)	Dark-grey calcareous shaly flags. } 300 feet.	Dark - grey calcareous flaggy shales (600 to 700 feet?).		Middle Coldwell (?).
Zone of <i>M. vulgaris</i> , sp. nov.	Wenlock Limestone.	Wenlock Shales. (Zone of <i>Cyrtograptus Lundgreni</i> .)	Wenlock Shales.	Moel Ferna Slates.	Lower Coldwell (?).

typical *M. leintwardinensis* of the highest zone has not yet been found, although its place appears to be taken by a varietal form. Two new species of graptolites are almost confined to this district. The succession worked out in these districts is confirmed by that in the Dee Valley and the Lake District, but the evidence at present obtained in the three other areas is only scanty.

The Lower Ludlow sediments become thicker, coarser, and more arenaceous when traced from the south and south-east to the north and north-west; but, in spite of this, there is a striking constancy in the lithological sequence of the sediments. Only two of the graptolitic zones, those of *M. Nilssoni* and *M. leintwardinensis*, are present in all the districts. A table is given to show the distribution of the graptolites in Britain and Europe, and one showing the order of appearance of the graptolites of the formation.

The Lower Ludlow graptolites present, as a whole, the following peculiarities, and stand in marked contrast to those from the Wenlock Rocks in the fact that while the polypary is straight for the greater part of its length, it is distinctly curved inwards at the proximal extremity. The apertures of the thecæ are for the most part either spinose, or wholly devoid of ornamentation. The number of species is eighteen, with thirteen varieties, of which six species and nine varieties of *Monograptus* and one species of *Retiolites* are new, and are described and figured in the paper. All the species and varieties of *Monograptus* are arranged round type-species into six groups. The richest groups in species and varieties are those of *M. dubius* and *M. colonus*. Most of these groups link the Ludlow Series with Wenlock, and even the genus *Retiolites* is common to the two formations. Thus the supposed great palæontological break between the two Series to a great extent disappears.

April 4th,—J. J. H. Teall, Esq., M.A., F.R.S., President,
in the Chair.

The following communications were read:—

1. 'Additional Notes on some Eruptive Rocks from New Zealand.'
By Frank Rutley, Esq., F.G.S.

The rocks described in this paper were, with a few exceptions, collected by Mr. James Park. A few of the specimens come from the area of the Hauraki Goldfields, but many of them were procured from other localities in the North Island, including several from Rotorua. The silica-percentages of several of the rocks have been determined by Mr. P. Holland.

The first part of the paper deals with twenty-three rock-specimens, and slides from them. These consist of rhyolites and obsidians, with rhyolitic and pumiceous breccias and tuffs, geyserites, and sinters. The rocks exhibit spherulitic and perlitic textures, fluxion, devitrification, and impregnation with silica. In one case the obsidian, after solidification, appears to have undergone the following changes:—(1) devitrification, with formation of spherulites; (2) increase in temperature sufficient to destroy the double refraction of spherulites and the earlier-formed feldspars; (3) the decomposition of parts of the spherulites, causing them to assume the characters of a coarse-grained felsite. The rocks from Rotorua

exhibit the effect of solfataric action resulting in the production of a high percentage of silica in the rock, and the development of hyalite and isotropic opal-silica or geyselite. In some cases these rocks have had silica substituted for portions of the spherulites which have been dissolved, the fibrous structure being preserved in opal-silica, which, nevertheless, exhibits double refraction.

In conclusion, the author suggests a comparison of certain ancient rhyolites of Great Britain with those of New Zealand affected by solfataric action. As to the causes which may convert a glassy into a lithoidal rhyolite we still seem to lack information: it is possible that the action of steam may be instrumental in effecting such a change, but this is probably only an occasional agent, and the more general cause of such changes must be sought elsewhere.

2. 'On the Discovery and Occurrence of Minerals containing Rare Elements.' By Baron A. E. Nordenskiöld, F.M.G.S.

The first mineral referred to is scheelite, and the next cerite, which contains no less than four rare metals. The incandescent light produced when the latter mineral is fused with charcoal-powder was first observed by Cronstedt in 1751. The discovery of glucina, lithia, selenium, and yttria is next referred to. Minerals containing yttria and oxides related to it were, at one time, thought to be almost limited to certain pegmatite-veins running in a broad zone on both sides of the 60th parallel of latitude. Latterly, fluocerite, orthite, and gadolinite have been found in Dalecarlia; and among these minerals Benedicks discovered a silicate of yttrium containing 1.5 per cent. of nitrogen and helium. The author discovered kainosite, a silico-carbonate of yttrium and calcium, among minerals from Hitterö; and the same mineral was subsequently discovered in the flucan, fissures, and drusy cavities at the Nordmarken mines. The last-mentioned discovery and others related to it appear to suggest that the mode of formation of fissure-minerals is not so unlike that of the pegmatite-veins of the Primary rocks as is generally supposed.

Thorium, discovered by Berzelius in 1829, was originally obtained from the rich mineral-locality of Langesund (called Brevig in mineralogical literature), but it has since been recorded from other localities, including Arendal and Finnish Lapland. It is now obtained from the monazite-sand of rivers in the Brazils and South Carolina. Thorite contains about .5 per cent. of inactive gas, probably a mixture of nitrogen and helium; but the latter element was first obtained from the mineral cleveite, also containing thorium, discovered by the author in 1877. Other minerals bearing nitrogen, argon, or helium are referred to; and under the head of minerals bearing tantalum, mention is made of Giesecke's discoveries in Greenland. Among these is fergusonite, one of the richest sources hitherto known for obtaining that mysterious gas, or mixture of gases, which on our planet seems to be almost exclusively confined to minerals containing rare earths. 'The group of earths, as well as the group of gases, of which we are here speaking, might, therefore, be compared with certain genera among organic beings, whose species, having not yet fully differentiated, offer to the descriptive zoologist or botanist difficulties analogous to those with which chemists meet in endeavouring to separate the rare earths and rare gases.'

THE
LONDON, EDINBURGH, AND DUBLIN
PHILOSOPHICAL MAGAZINE
AND
JOURNAL OF SCIENCE.

[FIFTH SERIES.]

SEPTEMBER 1900.

XXIV. *Considerations regarding the Theory of Electrons.*
By Prof. W. McF. ORR, *Royal College of Science, Dublin* *.

1. WHILE the theory of electrons developed within the last few years by Larmor goes far to elucidate the nature of electricity, to place the electromagnetic theory of light on a dynamical basis, to extend the region in which electric and optical phenomena may be considered as manifestations of the energy of one and the same medium into the domain of electrostatics, and to resolve difficulties in the explanation of the observed influences of matter on æther on the electric and magnetic as well as the optical side, the acceptance of one of its postulates as to the nature of electrons is not free from difficulty.

2. An electron or point-charge of strength e is defined † as a freely mobile singular point in the specification of the æthereal (rotational) strain such that very near it the strain assumes the form $\frac{-e}{4\pi} \left(\frac{d}{dx}, \frac{d}{dy}, \frac{d}{dz} \right) \frac{1}{r}$. The nature of the nucleus is not precisely specified; but it appears in keeping with the theory, and indeed suggested by its first development, to suppose that it may possibly be an exceedingly minute spherical portion of the æther devoid of rotational elasticity. If any number of such inelastic portions of any size and form exist, and be supposed fixed, the equations of

* Communicated by the Author.

† Larmor, 'Æther and Matter,' p. 86, Camb. Univ. Press, 1900.
Phil. Mag. S. 5. Vol. 50. No. 304. *Sept.* 1900. U

equilibrium of the æther* lead to the conditions that the vector representing the rotational strain should at the surfaces of the nuclei be normal, and outside them be the gradient of a function of the coordinates. This strain-vector can further be chosen so as to satisfy the conditions that outside the inelastic regions its concentration shall be zero, and that the surface-integral of the normal rotation over each such region shall have any assigned value. A state in which the rotation of the æther is identical with what the equilibrium electric displacement of Maxwell would be in case the inelastic regions were replaced by charged conductors, or if of exceedingly minute dimensions by point charges, is thus a possible (though not by any means the only possible) † state of equilibrium of the æther; and the explanation of electrostatic phenomena is so far satisfactory.

3. But in the development of the theory of moving electric charges, what is called the motion of an electron is the shifting of the centre of the strain from one point in the æther to another, the strain being altered, by continuous motion of the æther, except for portions lying in the track of the nucleus, from what it would be with the nucleus in one position to that which it would be with the nucleus in the other. What is contemplated is not a motion similar to that of a solid body, or a bubble of air, or a vacuous region, through a material fluid, or similar to that of a strain-nucleus through a material solid; not a displacement of the inelastic portion of the æther, but a transference of the inelastic property from one portion of the æther to another, or the annihilation of the electron in one position and its creation in another, and necessarily involves a constructive process of some kind. An analogy is, however, drawn between such an electron in the æther and a strain-nucleus in a material medium: in the original development of the theory this was pushed too far; it was stated that each is freely mobile ‡; in the latest statement it is, however, pointed out that a strain-nucleus in ordinary matter does not possess mobility of the kind postulated for an electron §.

* See Phil. Trans. A. 1894, p. 747, where, however, it is really only the varying part of the rotational strain-vector (f, g, h) that is expressed as the curl of another vector, for such a representation of the total strain implies that the surface-integral over any closed surface of the total normal rotation is zero; or § 9, below.

† The concentration of the strain-vector might have arbitrarily assigned values throughout the elastic regions, corresponding to a volume-distribution of electricity throughout the free æther. It might indeed be urged against the theory that it does not explain why such a distribution never occurs.

‡ Phil. Trans. 1897, A. p. 212; 'Æther and Matter,' p. 97.

§ 'Æther and Matter,' p. 336, footnote.

4. And a mobility of this nature, even if it be not necessary in order to surmount difficulties in the theory of aberration of light, is absolutely required for the existence of a force between two electrons or other conductors. In the development of the theory, electric force appears in the variation of the energy as the coefficient multiplying the virtual displacement of the centre of the electron nucleus *, and the mechanical traction on the surface of a material conductor as the coefficient multiplying the virtual displacement of a portion of the surface of the conductor. But this variation of the energy is made on what amounts to the supposition that in the displacement of the surface of the nucleus or conductor any region of æther which is thereby encroached on loses its elasticity, and any region which is thereby vacated regains it. (The fact that this is probably what occurs effectively in the case of a finite material conductor, as the charge consists of a distribution of free electrons over its surface which, when in equilibrium, keep the interior free from electric stress, in no way vitiates the argument here presented. If this hypothesis be correct, the consideration of what happens when a portion of the surface of a material conductor is moved involves, and should be preceded by, the discussion of the motion of an electron.) If, on the other hand, the variation be made on the supposition that there goes on no such process of electric straining on one side and release on the other, but that the displacement of the surface involves the displacement of the surrounding æther in the same way as the displacement of a portion of the surface of a bubble of air involves that of the surrounding medium, then the corresponding coefficient may be proved to be zero. Such a supposition would therefore afford no room for electrostatic force between electrons or conductors, any more than ordinary hydrostatic theory shows an attraction or repulsion between two balls immersed in a material fluid.

And the difficulty could not be surmounted by supposing that the nucleus is not devoid of elasticity, but is a region of æther in which the concentration of the rotation-vector is not zero, corresponding to a volume-density of electricity therein, or that the nucleus is so small that the energy of the irrotational motion which would be caused by its displacement if the surrounding æther did not resist rotation, is negligible; or that the resistance of the æther to compression, though enormously great, is not infinite. On any of these hypotheses,

* Phil. Trans. 1897, A. p. 213; 'Æther and Matter,' p. 97.

when the æther has once assumed the equilibrium state appropriate to given positions of the electrons or conductors, the nuclei as well as the surrounding æther are in equilibrium, and there is no tendency for anything to move unless the continuity of the medium can be broken down in some way.

5. It is held by Larmor that a model of the electric field may be complete without exhibiting a direct mechanism by which electrostatic attractions and repulsions are transmitted across the æther from the surface of one conducting region or electron to that of another*. As these attractions and repulsions make their appearance as coefficients of the virtual displacements of electrons, such displacements being made on the supposition of "free mobility," it is, I think, evident that the reason his theory does not show the transmission of these forces through the æther is that it does not show any machinery by which the mysterious "mobility" of the electrons is provided and the constructive processes involved in their motion are performed.

6. Thus the illustration of the origin of the static mechanical attraction between positive and negative electrons given in the latest exposition of the theory † appears inadequate for the purpose. Here an ideal canal in the æther is imagined as filled up by a flexible wire of infinite torsional rigidity, and in continuous connexion with the surrounding æther; the rotational displacement of any cross-section C round its axis by an impressed torque is transmitted all along the wire, and thence to the surrounding æther, and two complementary electrons are thus developed at its ends A and B, which persist as long as the rotational displacement of C is maintained. The author then states that the tangential tractions which the surrounding æther exerts on the surface of the wire form a system of forces statically equivalent by the principle of virtual work to an attraction between its ends, and that the mechanical attraction between the electrons may in this manner be considered as transmitted by the wire. This cannot be the case, however; the tangential tractions are proportional to the strains, and therefore so also is their resultant, if any, whereas the electrostatic force to be explained is proportional to the square of the strain; any mechanical force on the electrons would in fact be reversed by reversing the torque imposed on the wire, that is by interchanging the positions of the positive and negative electrons. This consideration, taken in conjunction with those of symmetry, shows in fact that if the wire be originally

* For the reasons assigned, *cf.* Phil. Trans. 1897, A. p. 212.

† 'Æther and Matter,' p. 329

straight the electrons are in equilibrium. Contrary to the assumption implicitly made in thus appealing to the principle of virtual work, such electron-models are not "freely mobile"; when the ends of the originally straight wire are moved from A, B to A', B', by bending it after the electrons have been formed, the resulting equilibrium-strain in the æther is not precisely the same as that due to two real point-charges at A', B'. In the former case, at every point P of the wire the components along the normal to its surface of the vectors which represent the æthereal strain and the rotational displacement of the element of surface of the wire are the same; in the latter the strain-vector is the resultant of $e/4\pi \cdot A'P^{-2}$ along A'P, and $-e/4\pi \cdot B'P^{-2}$ along B'P. The strains cannot then in general be the same.

The strain-distribution in each of the above cases, moreover, is different from that which would exist if the wire were first bent into the new position, then connected to the æther, and afterwards rotated by the imposed torque.

The specification of this illustrative model can however, I believe, be amended so as to permit the existence, and show the transmission, of attraction between the electrons. The following mode of doing so, though perhaps not very elegant, would serve this purpose. Suppose the wire replaced by an indefinitely long hollow tube, having only slight resistance to torsion, and riding loose on a concentric fixed rigid shaft; let keyways parallel to the axis be cut on the inside of the tube and on the shaft, in such positions that in order to key the tube and shaft together the former must be rotated against the reacting torque of the æther; and let the rigid key, of finite length, which fits in these ways, terminate in rounded or spherical ends. If the tube be now thus forcibly rotated around its own axis, and keyed to the shaft, the equilibrium-strain in the æther will, as the torsional resistance of the unkeyed portion of the tube is only slight, be almost identical with that due to two conjugate electrons coinciding with the spheres. Also the portions of the keyway on the tube beyond the spheres will assume the form of spirals of some kind very flat near the spheres, and will therefore touch the latter at some point or points so situated that the resulting pressures will not be at right angles to the axis of the shaft, but will have components urging the spheres towards each other. And, further, these electrons are "freely mobile" along the line joining them; an alteration of the length of the key merely alters the distance between the electrons. An endlong thrust in the key at the same time prevents this mobility coming into play, and resists the

attraction between the electrons. We may finally suppose the key made in two parts which can slide or telescope over each other, and the mobility of the electrons in the direction of the line joining them has free scope.

At the same time these electron models are totally devoid of mobility in any other direction, and exert no mechanical force on any electrons but each other.

Thus in this instance the same mechanism that provides for "free mobility" transmits the mechanical force. The transmission, nay the existence, of electrostatic force and the existence of "free mobility" are, it seems evident, intimately connected, and are explained or unexplained together.

7. "Free mobility" of electrons is, as stated by the author of the theory, one of its fundamental postulates. While willing to admit that from one point of view he is justified in endowing the æther and the electrons with any properties, limited in number and consistent, necessary for the explanation of observed phenomena, and to grant the possibility of such a mobility as a thing unexplained, I venture to think that it is a most mysterious property, unmaterial, and, in that it possibly demands something else than æther to perform the constructive process which is required, almost superæthereal; that it involves a far larger concession than does a rotationally elastic æther; that no model illustrating the properties of the primordial medium can be complete as regards electrical phenomena, unless it explains the nature of the constitution of an electron, the origin of its "free mobility," and the transmission of mechanical attraction or repulsion; and that in respect of this last the theory of electrons, in its present stage of development, might be held to be little more satisfactory than that of direct action at a distance.

8. It is pointed out by Iarmor* that if the range of molecular action were comparable with the size of the element of mass that is sensible to our powers of observation, the potential-energy function of a strained material medium would involve second as well as first differential coefficients of the displacements; in which case disturbances would still be transmitted by the medium but not by the agency of simple elastic stress definable in terms of surface tractions alone. In such a case, our notions of force, and of elastic stress as well, would be different from and wider than what they are; but the state of things as regards the theory of elasticity of such bodies would, I think, resemble the actual state in that we should still succeed in describing the phenomena of motion as well as of rest of the various parts of a material body as due to

* 'Æther and Matter,' p. 331.

the equilibrium or want of equilibrium of the forcives of which we should then have to take cognizance, instead of finding, as in the theory of electrons, that the play of forcives, in terms of which we describe the state of equilibrium of the æther under the influence of fixed electrons or conductors, is inadequate to account for what happens to the æther which lies in the path of a moving electron.

9. Some analysis, slightly modified from that given by Larmor *, bearing on the subject under discussion is here sub-joined. Suppose the medium compressible, incompressibility being regarded as a limiting case, and let the surface bounding an electron-nucleus be considered as a surface in crossing which there is discontinuity of elastic quality, compressive or rotational, or both. As the mechanical forces whose genesis is in question are proportional to the squares of the rotations, it is requisite that the equations should be correct as far as terms of that order in those strains, though not necessarily in the compressions. Let V denote the volume, and ρ the density of an element of æther, which when free from strain occupies volume V_0 and is of density ρ_0 , and let the pressure be $A^2\Delta$, where Δ denotes the compression, *i. e.* $(V_0 - V)/V_0$ or $(\rho - \rho_0)/\rho$; then the compressive potential energy is $A^2\Delta^2/2\rho_0$ per unit mass. It may plausibly be supposed that compression of an element does not affect the rotational potential energy, and accordingly the latter is represented by $\frac{1}{2}a^2(f^2 + g^2 + h^2)$ per unit mass instead of by $\frac{1}{2}\rho_0 a^2(f^2 + g^2 + h^2)$ per unit volume, where (f, g, h) is the rotational strain. Let ξ, η, ζ be the components of the displacement of the element of æther which is at the point x, y, z at the time t from the position it occupied at the time zero. The conditions of equilibrium are then to be derived from the variation of the potential-energy function

$$W = \frac{1}{2} \int a^2(f^2 + g^2 + h^2) dm + \frac{1}{2\rho_0} \int A^2 \Delta^2 dm,$$

wherein dm denotes an element of mass. Let D denote a variation following the motion of an element. Then

$$Df = D \frac{d\xi}{dy} - D \frac{d\eta}{dz}$$

and

$$\frac{\rho}{\rho_0} D\Delta = - \frac{DV}{V} = - \frac{d}{dx} (D\xi) - \frac{d}{dy} (D\eta) - \frac{d}{dz} (D\zeta).$$

On conducting the variation for the portion of the medium

* Phil. Trans. 1894, A. pp. 747, 793.

in any homogeneous region, we accordingly have

$$DW = a^2 \int \left\{ f \left(D \frac{d\xi}{dy} - D \frac{d\eta}{dz} \right) + g \left(D \frac{d\xi}{dz} - D \frac{d\xi}{dx} \right) + h \left(D \frac{d\eta}{dx} - D \frac{d\xi}{dy} \right) \right\} dm - A^2 \int \Delta \left\{ \frac{d}{dx} (D\xi) + \frac{d}{dy} (D\eta) + \frac{d}{dz} (D\xi) \right\} \frac{dm}{\rho}.$$

Replacing dm by ρdv , where dv denotes an element of volume, and integrating by parts, this is equivalent to

$$\int \left\{ [a^2 \rho (ng - mh) - lA^2 \Delta] D\xi + \dots \dots \dots \right\} dS + \int \left\{ \left[a^2 \left(\frac{d(\rho h)}{dy} - \frac{d(\rho g)}{dz} \right) + A^2 \frac{d\Delta}{dx} \right] D\xi + \dots \right\} dv,$$

where (l, m, n) represents the direction of the normal to the element of surface dS . Replacing $A^2 \Delta$ by ρ the vanishing of the volume-integral in this expression for all possible types of variation of ξ, η, ζ leads to the equation

$$a^2 \left(\frac{d(\rho h)}{dy} - \frac{d(\rho g)}{dz} \right) + \frac{d\rho}{dx} = 0,$$

and two analogues. And the consideration of the surface-integral leads to the conditions that

$$a^2 \rho (ng - mh) - lp$$

and its two analogues should be continuous across any surface of discontinuity. These surface conditions express that ρ should be continuous, and that

$$(\rho_1 a_1^2 f_1 - \rho_2 a_2^2 f_2) / l = (\rho_1 a_1^2 g_1 - \rho_2 a_2^2 g_2) / m = (\rho_1 a_1^2 h_1 - \rho_2 a_2^2 h_2) / n,$$

where the suffixes refer to the two sides of the interface.

The equations obtained from the vanishing of the volume-integral lead by differentiation to

$$\nabla^2 \rho = 0$$

throughout any homogeneous region ; and by integration give

$$\int \frac{d\rho}{dn} dS = a^2 \int \rho (f dx + g dy + h dz),$$

wherein the left-hand member is taken over any open surface which lies altogether in a homogeneous region, and the right-hand member is taken along the bounding edge. Hence the integral on the left vanishes for any closed surface which does not intersect any surface of discontinuity but may completely enclose any number of such.

From this result and the previous equation we deduce that the pressure is constant through each separate homogeneous region, which taken in conjunction with the surface condition shows that it is constant everywhere.

The equations satisfied by (f, g, h) now lead to

$$a^2\rho(f, g, h) = -(d/dx, d/dy, d/dz)V,$$

where V is some function of position. But we cannot deduce that ∇^2V should be zero.

The equilibrium conditions thus admit of far more general solutions than the equations of equilibrium in an actual dielectric. They are, however, satisfied by any solutions of the latter. And they are satisfied without it being necessary to apply any extraneous forces to the surfaces of discontinuity, *i. e.* the surfaces of the electron-nuclei; that is to say, the assumptions made do not account for attractions or repulsions between electrons, on the present hypotheses which do not include "free mobility."

If, adopting the other alternative as to the exact form of the rotational potential-energy, we suppose it to be $\frac{1}{2}\rho_0 a^2(f^2 + g^2 + h^2)$ per unit volume, the effect on the equations of equilibrium is merely to replace throughout

$$\rho(f, g, h) \text{ by } \rho_0(f, g, h)$$

and

$$p \text{ by } p + \frac{1}{2}a^2\rho_0(f^2 + g^2 + h^2).$$

10. It should be stated that the above remarks are the outcome of a discussion with Larmor, in which the views I at first expressed were shown by him to be in many respects mistaken, and in others have been considerably modified. In particular, the above analysis was put forward in an erroneous form to explain the transmission of mechanical force without postulating "free mobility," by showing a supposed incompatibility among the complete equations of equilibrium in the absence of extraneous forces on the electron-nuclei.

[*July 23.*—Mr. Larmor sends me the following rejoinder:—

In the rotationally elastic model which your paper considers, the gradient of the translatory displacement (ξ, η, ζ) is proportional to magnetic force; but your argument, § 4 and § 9, tacitly takes it to be also continuous with the velocity of the matter: such a scheme cannot be wide enough, as in fact you say. I should thus reply to § 9 that virtual variation of the æther-strain and virtual displacement of the material system are independent operations: you do not introduce the latter, so

you do not obtain ponderomotive forces, but only æthereal forces. (For the distinction between æthereal forces and electric forces, *cf.* 'Æther and Matter,' p. 97.) You will, in reply, ask for a model of an electron which will enable you to introduce the virtual displacements of the different elements of the surface of its nucleus, on which you can locate the action of the mechanical force. And you will in fact anticipate that it cannot be given: that all that one can definitely picture is the displacement of the electron as an aggregate. The electron has to be postulated as able to traverse the medium like a shadow without displacing it. It seems to be an undue limitation of possibilities when you assume that the nucleus *must* have a definite surface to which mechanical traction can be applied: a vortex-ring circulating round a vacuous core, in fact a vortex atom, is a structure which forms, or may be held to form, a case in point. This, as you say, amounts to postulating "free mobility" without explaining it: but the permanence and mobility of the strain-configuration as a whole, which really constitutes the electron, are, I think, intelligible in the model except in the *immediate* neighbourhood of the singular point at its centre, so that on postulating mobility for the unknown core all else is explicable. As regards the remark towards the end of § 9, and in the footnote to § 2, that the electrification might be spread continuously through the medium instead of being concentrated in electrons, that sort of generality of course destroys the physical simplicity of the scheme, which makes an electron an isolated structural singularity in an unmodified æther, and it is not called for by any facts. I admit that the representation which you discuss in § 6 is, as it stands, so imperfect as to be misleading rather than helpful. In 'Æther and Matter' § 37 should be deleted: see § 73.]

XXV. *The Genesis of the Ions in the Discharge of Electricity through Gases.* By J. J. THOMSON, M.A., F.R.S.*

IN many cases of discharge through gases, the ions have not to be supplied by the action of the electric field itself, but are produced by external agents such as Röntgen rays, radiation from uranium and other radio-active substances, the action of ultra-violet light on metals, incandescent filaments, &c. In addition, however, to such cases as these we have the very important series of phenomena which includes the spark-discharge and the ordinary discharge through vacuum-tubes,

* Communicated by the Author, having been read before the Cambridge Philosophical Society, Feb. 5, 1900.

in which there are no external sources available for the production of ions, so that these must in some way or another arise from the action of the field itself. There are many difficulties in the way of supposing that single molecules are torn asunder, by the electric force in the field pulling the positive ion one way and the negative ion in the opposite way. To mention only one of these difficulties, the electric force necessary to produce discharge is almost vanishingly small compared with the force due to an atomic charge acting at an atomic distance. In my 'Recent Researches' I suggested that under the action of the electric field some of the molecules formed long narrow aggregations, just as smoke and dust do under similar circumstances: these aggregations, being bodies of higher specific inductive capacity than their surroundings, will act on the lines of force like long and pointed conductors, and will therefore produce a great concentration of the lines of force on the ends of the aggregation, so that the maximum electric force in the field will be enormously greater than the average force, which is all we can measure. Since that was written, many investigations have been made which have proved that where electrified particles move through a gas ions are produced under certain circumstances, at any rate if the particle is negatively electrified. Thus Lenard showed that his rays make a gas through which they pass a conductor of electricity. Lenard rays are negatively electrified particles, and on our theory the conductivity of the gas is due to the production of ions. Again, I showed (*Phil. Mag.* Oct. 1897) that the passage of cathode rays through a gas ionized it. Thus we have evidence that in some cases at any rate the motion of the corpuscles through a gas can ionize it. The view that the motion of the ions through a gas can ionize a gas is supported by the observation of Stoletow (*Journal de Physique*, ix. p. 468) that under the same electric force the current between two plates, one of which is illuminated by ultra-violet light, increases with the distance between the plates, the increase being most marked when the pressure is low. This is what we should expect if the negative ions, starting from the illuminated plate, produced in the passage through the gas fresh ions. The view which I wish to bring forward in this paper, is that the ionization in the ordinary cases of discharge through gases is produced by the motion through the gas of ions or corpuscles already present in the gas. These ions or corpuscles under the action of the electric field acquire velocity and kinetic energy; and when this velocity or energy reaches a definite value, which need not be the same for the positive as the negative ion, these ions or corpuscles are able, by their collision with the surrounding

molecules, to produce other ions and corpuscles. This dissociation may be directly due to the collision, or indirectly to rays like Röntgen rays produced by the collision. Let us take the case of a gas through which a few ions are distributed: then, if the energy or velocity communicated by the electric field to these ions exceeds a certain critical value, each of the original ions will produce other ions, and these new ions will give rise to fresh ions, so that the number of ions and the conductivity of the gas will rapidly increase; it will go on increasing until the conductivity of the gas reaches such a value that the strength of the electric field is reduced so that the work done by it on an ion is equal to the critical value; when this stage is reached each ion produces one and only one successor, so that the number of ions remains constant, and the gas, with the discharge passing through it, attains a steady state.

If the strength of the field had been so small that the work done on an ion was not equal to the critical value, the number of ions would not increase, and there would be no discharge through the gas beyond the very slight leak due to the ions originally present in the gas. Thus this view explains why a field of finite strength is required to send the discharge through a gas.

The maximum kinetic energy given by the field to an ion will be measured by the work done on the ion during its free path, for after a collision the disturbance in the energy and direction of motion is so great that the work has as it were to be begun over again; while if the direction of the motion is reversed the field, if it increased the kinetic energy of the ion before the collision, will diminish it afterwards. Thus if λ is the mean free path, the kinetic energy given by the field to the ion will be measured by $F e \lambda$, where e is the charge on the ion and F the electric force. The condition that discharge should take place is that the maximum kinetic energy should equal q , where q is a quantity depending on the nature of the gas. Thus the condition for discharge is $F e \lambda = q$, so that F , the electric force required to produce discharge, varies inversely as the mean free path of the ions or corpuscles.

Now λ is inversely proportional to the density of the gas, so that on this theory the electric force required to produce discharge should in the same gas be directly proportional to the density of the gas, a result which is approximately true over a wide range of pressures. Thus the theory we are describing gives a very simple explanation of the fact that it is easier to produce a discharge through a gas at a low pressure than through one at a high.

The theory readily explains why it requires a greater electric force to send a spark through a thin layer of gas than through a thicker one, provided the thickness of the thin layer is less than a certain value which is inversely proportional to the pressure. For in order that the ions should produce dissociation, it is necessary that they should strike against the molecules of the gas, or if the dissociation is due to rays produced by the collision, that the layer should be thick enough to absorb the radiation; but as soon as the thickness of the layer becomes comparable with the mean free path of an ion, the chance of their striking against a molecule before reaching the electrode begins rapidly to diminish; so that the ability of the moving ions to produce dissociation will rapidly diminish when the thickness of the layer falls below a certain value. And although the thickness of the layer when the electric force begins to increase is large compared with the free path of a molecule moving through the gas, it is not so compared with the free path of a corpuscle; *i. e.*, one of the small ions which are found in the cathode rays, and which we have reason to believe play an important part in all cases of electric discharge.

On this view of the electric discharge, the presence of a small number of ions is required to start the discharge. The experiments of Linss*, and the recent ones of Elster & Geitel†, seem to show that such ions are present in air under ordinary conditions; the first spark, too, is more irregular in its behaviour than subsequent ones, and in accordance with the view that the conditions attending its formation are capricious and almost accidental.

Let us now consider the more complicated phenomena attending the passage of the discharge through a gas at low pressure. The production of ions may take place throughout the tube, or it may be localized in certain places. There must, however, be at least two places where ionization takes place. For on this theory the ionization at a place A is produced by ions brought into A by the electric field, so that there must be some other centre or centres of ionization to produce the ions which are brought into A by the electric field. In the 'Philosophical Magazine' for March 1899 I showed how, from the study of the distribution of electric force in a discharge-tube, we could determine the places of maximum ionization; the result of such an investigation leads to the

* W. Linss, *Meteor. Zeits.* iv. p. 352 (1887).

† 'Terrestrial Magnetism and Atmospheric Electricity,' iv. p. 213 (1899).

conclusion that there is one centre of ionization close to the cathode, and another in the negative glow.

According to the view taken in this paper, these centres form mutually dependent and, as it were, regenerative systems,—the ionization in the negative glow being due to the corpuscles coming from the centre close to the cathode, while the ionization close to the cathode is due to the positive ions which come from the centre in the negative glow. This view seems in accordance with the experiments of Villard*, in which a screen placed between the negative glow and the cathode stopped the emission of cathode-rays from the portion of the cathode shielded by the screen.

The negative corpuscles starting from the cathode ionize the gas in the neighbourhood of the magnetic glow, producing in this region a large number of ions; this makes the region one of great electrical conductivity, and the electric force consequently falls to a very small value. Let us now trace what would happen if there were no centre of ionization between the negative glow and the anode: the current in this part of the tube would be carried by the negative ions produced in the negative glow, such a distribution of ions in the tube would cause the electric force to increase as we approach the anode, and, if this increase did not cause the kinetic energy of the ions to exceed the value at which they begin to produce other ions, the electric force would increase uninterrupted up to the anode. If, however, the electric force increased to such an extent that the energy the field communicates to the ions is greater than that required for the dissociation of the surrounding molecules into other ions, then in the region where the electric force reaches this value fresh ions will be produced. This will increase the conductivity of the gas, and therefore cause the electric force to diminish: thus, after reaching a certain value, the electric force will fall off, and then begin to increase again after it has sunk below the value at which ionization takes place. If this were repeated several times before the anode was reached, we should get the electric force waxing and waning, as it does in the striated discharge. The view that the striations consist of alternations of layers of high conductivity due to the ionization of the gas by an electric force exceeding a certain critical value, with layers of gas through which the electric force is too low to produce ionization, accounts for the distance between the striations diminishing as the density of the gas increases, and also for the distance between the striations in a tube of unequal bore being less in the narrow than in the broad parts

* Villard, *Journal de Physique*, Jan. 1900.

of the tube. The electric force in the striated part of the discharge is much less than that close to the cathode; and it might be urged that if such an intense field were required to ionize the gas close to the cathode, the smaller field in the striated discharge would not produce ionization. It must, however, be remembered that the ionization at the cathode has to be produced by *positive* ions, while that in the rest of the field may be due to negative corpuscles; and it may very well be the case that the large positive ions are less efficient as ionizers than the negative corpuscles.

XXVI. *Some Lecture Experiments illustrating Syntony.*

By PHILIP E. SHAW, B.A., B.Sc.*

IN the Journal of the Institution of Electrical Engineers (Feb. 1899) will be found an account by Prof. Oliver Lodge of his researches in Magnetic Space Telegraphy. The present writer then set up some apparatus to show these methods in a popular lecture. Considerable difficulties soon presented themselves, but success was ultimately attained. Those who are conversant with the above paper will admit that the theory involved in it is of importance, and that any new demonstration of it would be valuable.

Besides the interest attaching to the theory of syntony, this method of magnetic space-telegraphy has promise of practical and commercial value, and has been shown already by Prof. Lodge to work well over considerable distances.

The following brief account contains a notice of the general method, of special details introduced by the author, and of precautions to be adopted.

Theory.

A summary will be given of the more essential points.

I. The frequency (N) of a circuit of capacity S and self-induction L is

$$N = \frac{160}{\sqrt{L \cdot S}}$$

where L is reckoned in henries and S in microfarads.

II. The mutual induction of two parallel coaxial coils of turns n and m , radii a and b , at distance r apart is, assuming r large,

$$M = \frac{m\pi a^2 \cdot n\pi b^2}{r^3}$$

* Communicated by the Physical Society: read March 23, 1900.

III. The self-induction of a short flat coil, as used for sending or receiving, is

$$L = 4\pi\mu n^2 a \left(\log_e \frac{8a}{c} - 2 \right),$$

and for a long solenoid (neglecting a small correction for the ends)

$$L = \frac{4\pi\mu n^2 A}{l}.$$

$$\left\{ \begin{array}{l} n = \text{number of turns;} \\ a = \text{radius of coil;} \\ c = \text{radius of wire;} \\ L = \text{length of solenoid;} \\ A = \text{mean sectional area.} \end{array} \right.$$

$$\text{IV. Current Amplitude} = \frac{E_0/R}{\sqrt{1 + \frac{L}{SR^2} \left(\frac{p}{p_0} - \frac{p_0}{p} \right)^2}},$$

where $\frac{p_0}{2\pi}$ = natural frequency of circuit,

$\frac{p}{2\pi}$ = frequency of alternating-current in circuit;

but for exact resonance, the current-amplitude = E_0/R ; hence for sharp resonance (since then $p = p_0$), $\frac{L}{SR^2}$ must be large.

V. Magnification Ratio, due to resonance, is given by the expression

$$\frac{V}{E_0} = \frac{pL}{R},$$

supposing the damping is small;

where E_0 = impressed E.M.F. from current source,

V = effective potential-difference at the condenser-terminals.

Now we have as far as possible to arrange the circuits in accordance with the above principles, and where these seem mutually in opposition to make a judicious compromise.

The *desiderata* are:—

- (1) R small, to obtain large current-amplitude, small damping, sharp resonance, and large magnification-ratio. Notice that R includes hysteresis if an iron core is used, and eddy-currents in neighbouring circuits.

- (2) *L* large, to obtain sharp resonance and large magnification-ratio.
- (3) *S* small, to obtain sharp resonance and to avoid large sparks at 'make' and 'break.'
- (4) *Radius of sending and receiving coils large*, to obtain large *N*.
- (5) The auxiliary coils must be suited to conditions (1) and (2), otherwise they may have any size or shape. For the comparatively small frequency used, the self-induction part of the impedance need not be considered.

The Circuits.

The sending-circuit is shown in the sketch (fig. 1), which is in elevation. The current leaving the cells at the top end

Fig. 1.

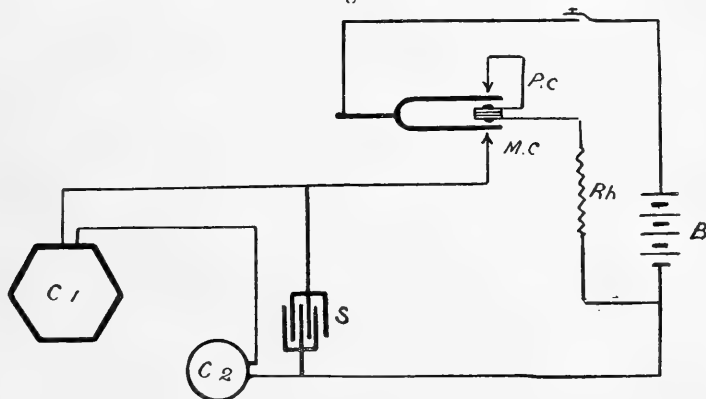

passes through the key, fork, platinum-contact (P.C.), rheostat, and to the lower end of the cells; the fork is worked by the passage of this current through the electromagnet between the prongs of the fork.

But there is another branch to the circuit, beginning at the mercury-contact (M.C.), then through the coils C₁ and C₂, the adjustable condenser S being put as a shunt to the two coils, then to the lower end of the cells.

Thus if S were removed we should obtain current-alterations in the coils of the frequency (100) of the fork; but with S in place, we have a frequency depending on the values of L and S in the coils. In setting up the system we select suitable coils and condenser, calculating the values of L from the dimensions of the coils; then put in such a value of

S as will give the required frequency, and finally adjust to a maximum by the iron core in C_2 (see expression I.).

This frequency (400 was used) must be an exact multiple of that of the fork (100), then between each charge received by S from the fork, there would be four complete surgings between S, C_1 , C_2 ; the potential changes would be considerable, and violent shocks might be obtained.

L may be varied by the introduction of any number of coils at C_2 , or by moving a core of iron wires in C_2 . This latter is a convenient adjustment, but wasteful on account of hysteresis. The adjustments are (1) the mercury-contact (M.C.), (2) the rheostat, (3) adjustable L in C_2 . Place one ear on the flat condenser (taking care to avoid getting a shock from its terminals), listen to the note heard in it, and change (1), (2), and (3) up to maximum loudness. The adjustment (1) must on no account be neglected; the method adopted was to have the fork rigidly held, but capable of being rotated by any small amount in a vertical plane.

Thus, as above described, we have a circuit with a given frequency, whose note can be raised to a maximum intensity.

Now turn to the secondary (or receiving) circuit (fig. 2).

Fig. 2.

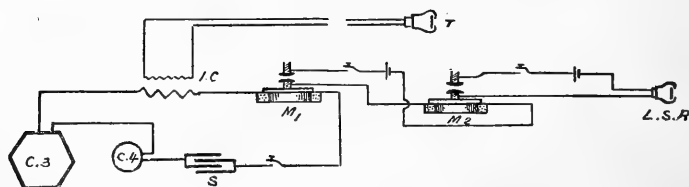

The coil C_3 is placed parallel to C_1 , and catches the waves from it; C_4 is an auxiliary coil. The condenser S is in series in the circuit, and not, as in the primary, shunted across the ends of the coils. There are two other coils in the same circuit:—(1) M_1 is the coil of the relay, with its microphone-carbons shown above it; (2) the small resistance-winding of a telephone induction-coil, the large resistance-winding being in series with the telephone T.

If now the coil C_3 is taking up the waves from the sending-circuit, and the variables C_4 and S are set for exact tuning (to frequency 400) a note of maximum loudness will be heard in the telephone T. In the primary it is convenient, though wasteful, to have an iron core in a coil for the small adjustment of L, but in the secondary it would be useless, since μ is small for the very weak currents existing.

Now put in the first relay by adjusting the carbons at M_1 . The action occurring at M_1 and M_2 must be explained in detail. The coil M_1 lies in a horizontal annular space in which the lines of force run radially, and normal to the wires in the coil ; then if current-alternations occur in the coil, it is impelled up and down with the frequency of the alternations ; the field meanwhile is maintained constant by a separate strong current (say 10 amps.). The movements of the coil will, by the action of the microphone, produce alternating currents of a higher order of intensity in the relay-coil M_2 ; and this, in turn, will in like manner give strong currents in the last circuit, producing a loud note in the loud-speaking receiver (L.S.R.). Although, to avoid confusion in the diagram, no such connexions are shown, it is easy to put the induction-coil and telephone (I.C. and T.) into the second circuit, and by them adjust the working of M_1 to a maximum intensity.

The relays should be guarded from all vibrations by being put on blocks resting on soft rubber balls ; also they should be on separate blocks, otherwise the action of one will start the other.

Description of the Relay.

The principle involved is due to Prof. Lodge, and is found in his magnifying-telephone ; but the attachments of the coil and the system suspending it are due to the author, and will be shortly described.

Fig. 3.

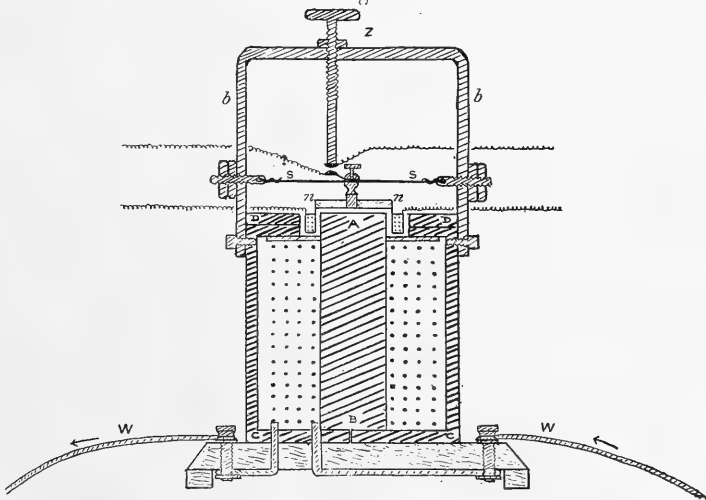

The wires WW (fig. 3) carry the strong current (say 10 amps.) used to produce a field ; the magnetic circuit of

soft iron is seen to be ABCDA ; it has the air-gap between D and A in which the coil nn lies. This is the coil M_1 or M_2 in fig. 2.

The coil nn is very light, 60 turns of covered copper wire (36 s.w.g.), resistance about 4 ohms, wound on a paper pill-box, which is light and rigid and perfectly circular, and is hence a very convenient former for the coil. The steel wire ss has a light brass fitting screwed tightly to its centre ; below this is a light bow of cedar lashed and cemented to the brass above and lashed and cemented to the coil below.

As seen in the sketch, the wire is fixed (bent on itself and brazed) to a brass screw at each end, each provided with two nuts, on the outside of the stout brass frame bb .

By tightening the wire we can produce in it the required frequency, 400 (this can be observed by gently tapping the wire and listening for its natural frequency) ; then alternations in the current of nn must produce vibration in the wire ss , and when the carbons are set by the screw z we have the microphone acting.

Two graphite buttons, or one graphite and one hard carbon button, were found to act very well.

Another form of relay was used. Take a Blake transmitter, change the stiff iron plate for a more yielding one, and attach the coil nn to it. This acts fairly, but is obviously not syntonic with the whole system as in the other case.

Manipulation.

The chief special difficulties may be mentioned categorically.

I. It must be borne in mind that in such an apparatus as that used, where the ratio $\frac{R}{L}$ is comparatively large, damping occurs rapidly, and consequently the current-amplitude dies out rapidly between each fresh charge received from the fork.

Fig. 4.



We supposed the fork to have frequency 100, and the circuit to have frequency 400. Then the curve for current would be of the nature shown in I.; whereas the ideal curve, where $\frac{R}{L}$ is negligible, would be as in II., where the amplitude is

seen to remain constant. Consequently in our system we should have a pronounced fundamental 100 as well as an harmonic 400, and we have to learn to pick out the latter and, in adjusting the circuit, to work it up to a maximum. This applies to both primary and secondary circuits.

II. Care must be taken to properly adjust the platinum and mercury contacts, not only to produce the maximum true sound in the circuit, but also to avoid any spurting at the contact ; this would have its counterpart in violent spurts in the sounds in the coils, which mask the true effect.

III. The greatest difficulty experienced, however, was in the microphones, both (1) in obtaining them truly syntonic with the circuit and with one another, and (2) in the minute adjustment of the carbons for very weak currents. The special relay described above worked well, but requires delicate handling in respect of both (1) and (2). Anyone who has worked a granular transmitter, or indeed any microphone with a view to obtaining *maximum* effects for very small movements, will admit that an exceedingly fine adjustment is required. This might seem to be self-evident, but the author has made independent research on this point, his results being that a movement of one carbon of the order 10^{-5} cm. would carry the microphone from hard contact (no microphone action) to complete freedom. Hence the difficulty above stated is quite intelligible.

In working the relay described previously, the final adjustment was made by gently pressing with the finger on the stout brass bar *bb* (the section of the bar is $\frac{1}{2}$ in. \times $\frac{1}{4}$ in.). This of itself indicates the delicacy of the microphone.

IV. The design of the sending and receiving coils. The author had in each of them 100 turns of insulated copper wire (16 s.w.g.), radius about half a metre, resistance about 3 ohms. If the same wire had been opened out to 50 turns of radius one metre in both sender and receiver, the mutual induction would be four times as great ; the self-induction of each would be slightly reduced (roughly to about two-thirds of its former value), but this could be made up in the auxiliary coils. Thus it is advantageous to have the radius of the coils large. In making the auxiliary coils we require to have large *L* with small *R*. If we have a given amount of wire at our disposal, it is better to have small radius and many turns, and have a core of iron wires for final adjustment. One advantage of keeping *R* moderately large in the circuit is that we run no risk of breaking down the condenser in the primary.

V. In Prof. Lodge's research the sound produced at the

receiving-telephone was very small, just sufficient for audibility being all that is required by a single observer; but in the case here discussed, we have to produce sounds to be given out to a large audience by a loud-speaking telephone; these would have to be, and were, thousands of times as great as required in the former case. The process of amplifying the small currents until they become large and produce really loud signals is a difficult one in itself; but an even greater one arises from the passage of large currents through the last microphone; the carbon-contacts are rapidly burnt away, and as a microphone contact is a very delicate one, continual adjustment is required.

To meet this special difficulty Prof. Lodge has employed an ingenious device which should be mentioned. The upper carbon is attached to a large mass which turns freely on a horizontal axis, which is so counterpoised that the two carbons are gently but steadily pressed together. If the carbons burn away at the contact, the pivoted system moves on its axis and maintains the same microphone-action as before. Thus the contact is kept automatically in working order.

It should be pointed out that though the sounds produced in the receiver were much louder than in the case of Prof. Lodge's system, yet the distance between sender and receiver was in his case very much larger; so that each arrangement has its own difficulties.

Another Experiment.

By a small modification in the primary circuit, tuning can be demonstrated in a very striking way. In fig. 1 put a loud-speaking receiver in series with the coils C_1 and C_2 , and shunt it by a resistance-box. On working the circuit this receiver gives out a loud sound of the circuit-frequency; by changes in the shunt we can affect its intensity, while by changes in L or C we alter its frequency. It may be mentioned in passing that this is a convenient means of producing a sound of constant intensity and is easily adjustable (though not necessarily pure), and as such it has been used by the author.

As a simple example, if we change the capacity from 0.9 mfd. to 0.4 mfd., then the frequency should change in the ratio

$\sqrt{\frac{4}{9}} = \frac{2}{3}$; the notes will be found to have about a musical interval of one-fifth.

The author's best thanks are due to Prof. Lodge for advice during the progress of the work.

XXVII. *On the Law of Cailletet and Mathias and the Critical Density.* By SYDNEY YOUNG, D.Sc., F.R.S., University College, Bristol*.

IN a very interesting paper (*Mém. de la Soc. Roy. des Sci. de Liège*, sér. 3, ii. 1899) M. E. Mathias discusses the law of the Rectilinear Diameter, discovered in 1886 by M. Cailletet and himself, and the law of the corresponding states of matter. The law of Cailletet and Mathias may be stated simply in this way:—The means of the densities of liquid and saturated vapour for any stable substance are a rectilinear function of the temperature.

It has been shown (Mathias, *Ann. de la Fac. des Sci. de Toulouse*, 1892; Young, *Phil. Mag.* Dec. 1892, p. 506) that if the generalizations of van de Waals regarding corresponding temperatures, pressures, and volumes are correct, the angular coefficient α [$D_t = D_0 + \alpha t$, where D_t and D_0 are the means of the densities at t° and 0° respectively] of the diameters of different substances should be directly proportional to their critical densities, and inversely proportional to their absolute critical temperatures; or that for any substance

$$\alpha = \text{const.} \times \frac{D_c}{T_c};$$

thus $\frac{\alpha T_c}{D_c} = \text{const.} = a$.

M. Mathias points out that in order to test the truth of the law of corresponding states, it is only necessary to ascertain whether a is really a constant. He then discusses the conditions necessary for the determination of a .

For a certain number of substances the critical temperature and the densities of liquid and saturated vapour from about the ordinary boiling-point to the critical point have been determined; and in these cases there is no difficulty. From the mean densities at a series of temperatures α is found, and D_c is then calculated from the formula

$$D_c = D_0 + \alpha(T_c - 273).$$

In the great majority of cases, however, the only density determinations that have been made are those of the liquid below the boiling-point. We may, however, calculate the densities of saturated vapour at these low temperatures if the vapour-pressures are known on the assumption that the vapour-density is practically normal; and thus the mean densities of liquid and saturated vapour may be ascertained.

* Communicated by the Physical Society: read June 22nd, 1900.

Now the law of Cailletet and Mathias has been found to hold good for a considerable number of substances from the boiling-point to the critical point; and M. Mathias, making the very natural assumption that the law may be relied upon at lower temperatures, calculates the value of α from the mean densities below the boiling-point. If the critical temperature is known, the critical density is then calculated as before; but for most substances the critical temperature has not been directly determined; and M. Mathias discusses the methods, notably that of Thorpe and Rücker, that have been suggested for calculating this constant.

M. Mathias shows that if, in Thorpe and Rücker's formula

$$T_c = \frac{T_2 d_1 - T_1 d_2}{A(d_1 - d_2)},$$

$A=2$, then it follows that $a=1$.

He further shows how, if $a=1$, it would be possible to ascertain both the critical density and the critical temperature by a geometrical method. In most cases, however, A differs sensibly from 2 and a from unity, and the geometrical method is then inapplicable; neither can the critical temperature be calculated with sufficient accuracy by employing the value of A , 1.995, adopted by Thorpe and Rücker.

It occurred to me that A , though not quite the same for different substances, might possibly be related to the composition in some simple way; and I have therefore calculated its value (taking 0° and the boiling-point under normal pressure as the two temperatures) for the thirty compounds referred to in this paper; these constants are given in Table I. Unfortunately there does not seem to be a sufficiently marked connexion between the values of A and the composition to be of much practical use.

M. Mathias arrives at the conclusion—which, I think (except for a few special cases), is quite justified—that it is necessary to make a direct determination of the critical temperature.

M. Mathias then proceeds to the examination of experimental data derived from various sources. The critical temperature, the vapour-pressures, and the densities of liquid chlorine have been very carefully determined by Knietsch; and M. Mathias has calculated the densities of the saturated vapour below the boiling-point ($-33^\circ.6$), and finds that the constancy of both a and D_c are apparently extremely satisfactory; but the value of a (.7675) is very far from unity. The value of D_c is .5782; but it may be pointed out that the ratio of this to the theoretical density at the critical tempe-

perature and pressure as observed by Knietsch is only 3·03, a very low number.

Among the other substances examined by M. Mathias is normal decane, for which the densities of liquid have been determined only at low temperatures. In this case the values of α , a , and D_c seem to be at variance with those obtained by myself for the lower normal paraffins, as will be seen from the table below :

	α .	a .	D_c .
Pentane	·000460	0·931	·2324
Hexane.....	·000446	0·967	·2343
Heptane	·000440	1·013	·2344
Octane	·000440	1·075	·2330
Decane.....	·000380	0·928	·2471

For the four lower paraffins α and D_c show very slight variations, whilst a rises considerably with increase of molecular weight, so that the values calculated for decane appear improbable.

In view of these apparently abnormal results it seemed advisable to undertake a careful examination of the whole of the data which I have obtained for thirty substances. In all cases except the alcohols the critical densities were calculated by the method of Cailletet and Mathias, the mean densities above the boiling-points only having been used except for one or two substances; and though the deviations from the formula $D_t = D_0 + \alpha t$ differ somewhat considerably, there did not appear to be any definite tendency to curvature except possibly in a few cases. I have, indeed, attributed these deviations to errors of experiment; and this view was strengthened by the fact that for normal pentane, with which very careful determinations were made from 0° to within 0°·05 of the critical temperature, the deviations were exceedingly small and well within the limits of experimental error.

As will be seen later, however, it turns out that in choosing normal pentane for this special investigation I happen to have hit on the one substance which does not show the slightest deviation from the law of Cailletet and Mathias.

Since the publication of M. Mathias's paper I have calculated the mean densities of all thirty substances at intervals of ten degrees between 0° and the boiling-point; and it became evident that for many of them the deviations increased rapidly below the boiling-point. Moreover, on plotting all the differences between the mean densities and those calculated from the formula $D_t = D_0 + \alpha t$ against the temperature, distinct curvature was noticeable in many cases. This will be

seen from the curves (fig. 1) for hexamethylene, benzene, normal heptane, and propyl acetate.

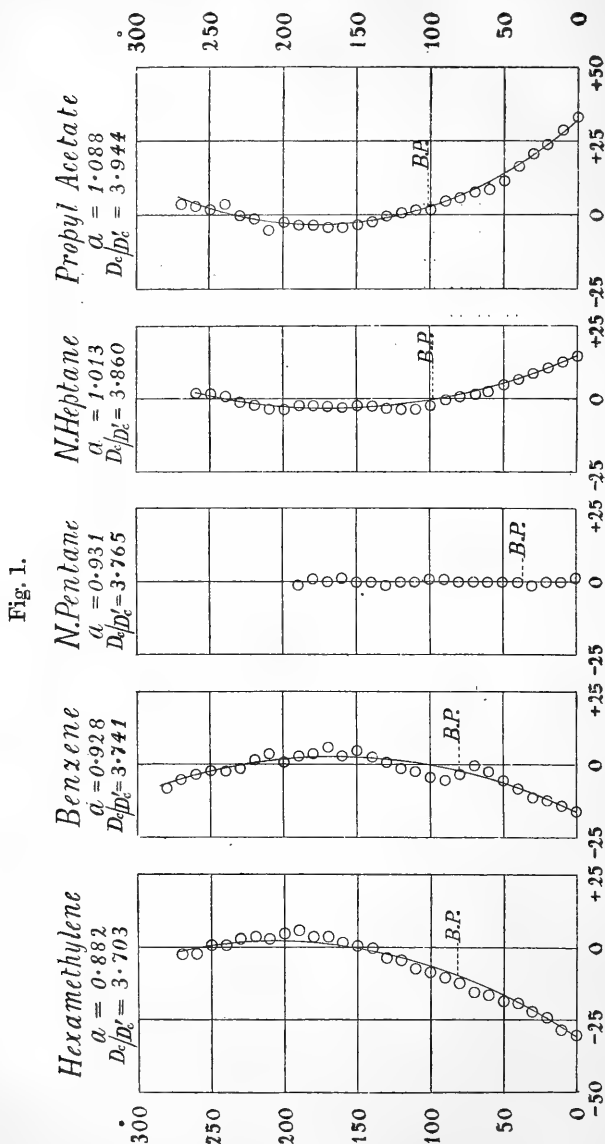

The drawn curves are calculated from the formula

$$D_e = D_0 + at + \beta t^2,$$

α being negative in these and all other cases (for both formulæ), whilst β is positive in the first two cases but negative in the last two.

For normal pentane it will be seen that there is absolutely no indication of curvature, so that $\beta=0$; for the alcohols, on the other hand, the curvature (in the same direction as that for propyl acetate) is so pronounced that a fourth term, γt^3 , has to be introduced into the formula to reproduce the data.

The values of a and of $\frac{D_c}{D'_c}$ [the ratio of the actual to the theoretical density at the critical point] are given for the five substances; those for methyl alcohol are very high, 1.142 and 4.521 respectively.

It is remarkable that as the curvature changes in such a manner that β passes from a positive value, through zero, to a negative value, a and $\frac{D_c}{D'_c}$ regularly increase. It is especially remarkable that for normal pentane, for which $\beta=0$, the value of $\frac{D_c}{D'_c}$ (3.765) is almost exactly that which may be taken as normal for substances whose molecules undergo no dissociation or polymerization. (The ratio given by van der Waals is $\frac{8}{3}=2.6$, but, as shown by Guye and by Heilborn, if we accept O. E. Meyer's correction for the relation between b in the formula of van der Waals and the space actually occupied by the molecules, this number should be multiplied by $\sqrt{2}$, which would give 3.77.)

That being so, we may perhaps take the normal value of a to be about 0.93.

It seems unnecessary to give the differences of the observed mean densities from those calculated from the formula $D_t = D_0 + \alpha t$ at intervals of ten degrees for each of the thirty substances, but in Table I. I have given the values of D_0 , $\alpha \times 10^6$, a , $\frac{D_c}{D'_c}$, $\frac{D_c}{D'_c} - 3.770$, the difference between the observed and calculated mean density at 0° , and lastly A (Thorpe and Rücker).

The substances are arranged in ascending order of $\frac{D_c}{D'_c}$, and it will be noticed that there is, on the whole, a distinct tendency for a to rise; thus the values of a on the one side of normal pentane are, with one exception (stannic chloride), lower than .931, and those on the other side are, again with one exception (fluorbenzene), higher.

TABLE I.

Name.	D_0 .	$\alpha \times 10^6$.	$a = \alpha \frac{T_c}{D_c}$.	Error in Mean density at 0° . Calc. - Obs.	$\frac{D_c}{D_c'}$.	$\frac{D_c}{D_c'} - 3.770$.	A (Thorpe and Rücker).
Carbon Tetrachloride8117	900	0.899	47	3.670	-0.100	1.996
Hexamethylene.....	.8954	436	0.882	30	3.703	-0.067	2.006
Isopentane.....	.8197	454	0.892	5	3.734	-0.036	1.984
Stannic Chloride	1.1356	1240	0.991	38	3.738	-0.032	1.934
Benzene.....	.4485	502	0.928	16	3.741	-0.029	1.986
Di-isopropyl8395	433	0.899	4	3.741	-0.029	2.022
Normal Pentane8231	460	0.931	0	3.765	-0.005	1.994
Fluorbenzene.....	.5224	587	0.927	9	3.791	+0.021	2.030
Chlorobenzene5650	550	0.949	11	3.794	+0.024	2.030
Iodobenzene8318	775	0.956	15	3.798	+0.028	(2.030)
Di-isobutyl5567	433	1.005	17	3.813	+0.043	1.978
Ether.....	.8687	547	0.974	2	3.814	+0.044	1.937
Bromobenzene7634	694	0.953	25	3.825	+0.055	(2.030)
Normal Hexane8390	446	0.967	4	3.827	+0.057	1.982
Normal Heptane8518	440	1.013	15	3.860	+0.090	1.980
Normal Isobutyrate4577	583	1.045	20	3.868	+0.098	1.996
Normal Octane8634	440	1.075	42	3.870	+0.100	1.959
Propyl Formate4658	590	1.025	14	3.871	+0.101	1.967
Ethyl Formate4759	649	1.021	17	3.885	+0.115	1.959
Methyl Propionate4721	621	1.055	27	3.903	+0.133	1.960
Methyl Butyrate4640	582	1.074	39	3.907	+0.137	1.956
Ethyl Propionate4587	593	1.090	25	3.917	+0.147	1.926
Methyl Formate5025	715	0.997	6	3.932	+0.162	1.982
Propyl Acetate4585	587	1.088	34	3.944	+0.174	1.943
Methyl Acetate4830	674	1.049	32	3.945	+0.175	1.975
Ethyl Acetate4644	625	1.061	22	3.949	+0.179	1.940
Ethyl Alcohol4138	556	1.043 *	107	4.016 *	+0.246	2.280
Propyl Alcohol.....	.4184	528	1.030 *	88	4.021 *	+0.251	2.277
Methyl Alcohol.....	.4190	602	1.142 *	189	4.521 *	+0.751	2.255
Acetic Acid5399	587	0.994	50	4.993	+1.223	2.077

* Critical density not calculated from formula, but read from curve constructed graphically.

Again, all the differences at 0° on the one side of normal pentane are negative, and with one exception (fluorbenzene) all on the other side are positive.

That there is a relationship of the values of α to the ratios $\frac{D_c}{D'_c}$ is clearly seen by the diagram (fig. 2).

Fig. 2.

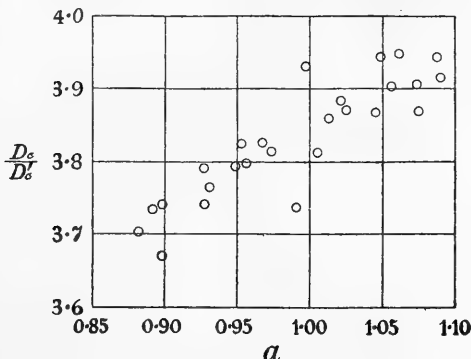

With regard to the differences at 0° , M. Mathias notices (*loc. cit.* p. 19) that at low temperatures the substituted ammonias give values of α that increase as the temperature falls, but he regards this as being due to the approach to the solidifying-point.

It appeared to me more probable, however, that in most cases the mean densities would be more accurately represented by the equation

$$D_t = D_0 + \alpha t + \beta t^2$$

than by the simpler one $D_t = D_0 + \alpha t$, and I therefore calculated the constants D_0 , α , and β for all the substances. For the alcohols, however, it was necessary to introduce a fourth term, γt^3 , to get a satisfactory agreement.

I am indebted to Miss E. C. Fortey, B.Sc., for much valuable assistance with these calculations.

The constants are given in Table II., and here it will be seen that whilst the values of α are without exception negative, those of β on the one side of normal pentane are all positive, and, with three exceptions, those on the other side are negative. These exceptions are: fluorbenzene, which was before found to behave abnormally; hexane, for which $\beta=0$; and methyl alcohol, for which γ has a very high negative value.

The relationship of β to $\frac{D_c}{D'_c}$ is well seen by the diagram (fig. 3).

Fig. 3.

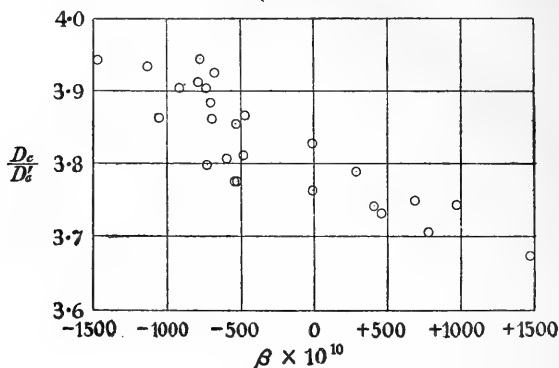

TABLE II.

Name.	D_0 .	$\alpha \times 10^7$.	$\beta \times 10^{10}$.	$\gamma \times 10^{13}$.
Carbon Tetrachloride	·8165	- 9564	+ 1480	
Hexamethylene	·3985	- 4685	+ 791	
Isopentane	·3202	- 4658	+ 463	
Stannic Chloride	1·1387	- 12760	+ 977	
Benzene	·4501	- 5248	+ 693	
Di-isopropyl	·3401	- 4445	+ 413	
Normal Pentane	·3232	- 4610	0	
Fluorbenzene	·5236	- 6000	+ 293	
Chlorobenzene	·5640	- 5337	- 509	
Iodobenzene	·9303	- 7556	- 519	
Di-isobutyl	·3550	- 4115	- 592	
Ether	·3685	- 5377	- 475	
Bromobenzene	·7609	- 6655	- 725	
Normal Hexane	·3388	- 4445	0	
Normal Heptane	·3504	- 4192	- 621	
Methyl Isobutyrate	·4558	- 5593	- 689	
Normal Octane	·3590	- 3954	- 1046	
Propyl Formate	·4647	- 5748	- 459	
Ethyl Formate	·4741	- 6251	- 694	
Methyl Propionate	·4696	- 5921	- 729	
Methyl Butyrate	·4601	- 5430	- 906	
Ethyl Propionate	·4564	- 5644	- 784	
Methyl Formate	·5020	- 7013	- 665	
Propyl Acetate	·4553	- 5469	- 1124	
Methyl Acetate	·4799	- 6280	- 1467	
Ethyl Acetate	·4624	- 5992	- 764	
Ethyl Alcohol	·4028	- 3827	- 5940	+ 651
Propyl Alcohol	·4095	- 3790	- 3750	- 5533
Methyl Alcohol	·4050	- 4479	+ 1330	- 23760
Acetic Acid	·5355	- 5366	- 1191	

A comparison of the results by the two formulæ is given in Table III. Under $\frac{\Delta}{n}$ are given the mean differences multiplied by 10^4 between the observed and calculated densities without regard to sign; under $\frac{\Delta'}{n}$, the algebraical sum of the differences multiplied by 10^4 and divided by the number of observations.

The numbers under I. refer to the formula with two constants, those under II. to the formula with three constants (four for the alcohols).

Taking the whole range of temperature for each substance it will be seen that the agreement when the three constants formula is used is very much better than when the simpler one is employed. Excluding the alcohols and acetic acid, the molecules of which are almost certainly of different complexity in the gaseous and liquid states, the mean value of $\frac{\Delta}{n}$ for the 26 substances is 5.40 for the formula with two constants as against 1.51 for that with three. That $\frac{\Delta'}{n}$ is very small in each case for the formula with three constants, not only for the whole range of temperature but also for the temperatures above and below the boiling-point taken separately, may be regarded as evidence that the curves represent the results with satisfactory accuracy; and, if that is so, the values of $\frac{\Delta}{n}$ for the same formula may be taken as a measure of the experimental errors which, it will be seen, differ considerably for different substances. The large errors in the case of stannic chloride may be explained by the fact that this compound attacks mercury at all temperatures whilst carbon tetrachloride does so at high temperatures, so that special experimental methods had to be devised. Again, the observations with iodobenzene had to be made by artificial light as the substance becomes rapidly coloured on exposure to daylight. Acetic acid gave a good deal of trouble at the highest temperatures, owing to repeated bursting of the tubes, but the comparatively large errors with ether and ethyl and propyl alcohol are not easily accounted for.

It remains to be seen whether the simpler formula $D_t = D_0 + at$ is sufficiently accurate to be employed for temperatures between the boiling-point and the critical-point. The values of $\frac{\Delta}{n}$ and $\frac{\Delta'}{n}$ above the boiling-point are therefore given in

TABLE III.

Name.	$\frac{\Delta'}{\%}$.				$\frac{\Delta'}{\%}$.					
	Whole Range.		Above B.-P.		Whole Range.		Below B.-P.			
	I.	II.	I.	II.	I.	II.	I.	II.		
Carbon Tetrachloride ...	12.00	2.54	4.15	3.05	-8.57	-0.04	-31.62	-0.75	0.65	+0.25
Hexamethylene	9.07	1.29	3.68	1.47	-6.64	+0.07	-20.44	-0.67	0.07	+0.42
Isopentane	1.95	0.68	1.50	0.69	+0.26	-0.05	4.33	-0.67	+1.12	+0.06
Stannic Chloride	9.17	3.35	5.18	4.29	-6.76	-0.17	-15.67	+0.33	-0.47	+0.03
Benzene	4.69	1.34	3.25	1.50	-2.48	+0.10	-7.89	+0.56	+0.05	-0.10
Di-isopropyl	2.57	1.09	2.06	1.06	-0.30	-0.13	4.00	-0.05	1.00	0
Normal Pentane	0.70	0.40	0.62	0.37	+0.10	+0.10	1.00	0	+0.37	+0.13
Fluorbenzene	4.72	2.24	2.21	2.10	-1.48	+0.17	8.11	-0.78	1.50	+0.60
Chlorobenzene	3.32	1.31	2.14	1.07	+0.39	-0.14	+1.93	-0.36	-1.14	+0.07
Iodobenzene	4.29	2.50	2.55	3.56	+1.86	-0.14	2.58	-0.74	+0.33	+1.11
Di-isobutyl	3.93	0.93	0.88	1.18	3.21	-0.07	8.64	+0.18	-0.29	-0.24
Ether	3.90	3.45	4.56	4.06	-1.30	-0.35	0.25	-1.00	1.56	-0.19
Bromobenzene	6.52	1.63	2.45	2.45	+4.89	+0.30	9.31	+0.06	1.55	+0.64
Normal Hexane	1.25	1.21	1.24	1.06	+0.25	+0.04	+0.71	-0.71	+0.35	+0.35
Normal Heptane	3.81	0.74	2.18	0.82	1.44	+0.15	6.60	0	1.59	+0.24
Methyl Isobutyrate	4.78	1.78	2.24	2.29	3.37	-0.07	9.30	-0.50	-0.12	+0.18
Normal Octane	10.83	1.00	2.29	1.29	+9.30	+0.20	22.00	-0.46	0.41	+0.71
Propyl Formate	2.89	1.41	1.39	1.39	+1.56	-0.15	5.89	+0.11	0.61	-0.28
Ethyl Formate	5.46	1.08	3.06	1.11	+3.29	+0.08	12.67	0	0.17	+0.11
Methyl Propionate	7.12	1.69	3.28	1.62	4.42	-0.15	15.75	-0.62	0.61	+0.06
Methyl Butyrate	10.14	1.17	2.67	1.50	+3.65	+0.21	22.36	-0.09	0.11	+0.39
Ethyl Propionate	5.14	1.68	1.44	1.67	+3.64	-0.04	11.40	-0.90	0.67	+0.44
Methyl Formate	2.00	1.36	1.78	1.55	+0.64	+0.27	3.00	0	0.11	+0.33
Propyl Acetate	7.54	1.04	2.53	1.00	+5.61	+0.04	15.27	-0.36	0.65	+0.29
Methyl Acetate	7.62	1.42	3.00	1.67	4.79	+0.25	21.50	+0.67	0.78	+0.11
Ethyl Acetate	4.92	0.92	1.65	0.71	+4.12	+0.04	11.87	-0.62	+0.59	+0.35
Ethyl Alcohol	29.40	4.28	14.59	5.18	+15.48	-0.52	60.87	+1.25	5.88	-1.29
Propyl Alcohol	26.11	4.22	20.00	5.35	+5.90	-1.55	33.70	+0.10	-11.29	+0.71
Methyl Alcohol	45.32	2.42	26.39	2.94	+15.88	+0.58	94.00	+0.29	-14.50	+0.71
Acetic Acid	11.06	4.13	6.00	3.95	+4.63	-0.13	19.33	-2.08	4.20	+1.15
Mean, excluding Alcohols and Acetic Acid	5.40	1.51	2.46	1.71	3.43	+0.14	10.54	+0.43	0.64	+0.30

the table, and it will be seen that the improvement effected by introducing the third constant is very much smaller than for the whole range of temperature. Thus the mean value of $\frac{\Delta}{n}$ falls only from 2.46 to 1.71, as against 5.40 to 1.51 for the whole temperature range, and for $\frac{\Delta'}{n}$ the fall is only from 0.64 to 0.30 as against 3.43 to 0.14.

There is therefore for this range of temperature, except in the more extreme cases (near the top and bottom of the table), not very much to choose between the two formulæ.

On the other hand a comparison of the values of $\frac{\Delta'}{n}$ for the two formulæ below the boiling-point brings out the difference between them in a most striking manner. For the formulæ with two constants the first eight values are negative, and the rest with one exception (ether, for which the experimental errors are large and the temperature range small) are positive, and, omitting the alcohols, they range from -31.62 to $+22.36$, or, including the alcohols, to $+94.00$. For the formula with three constants the $+$ and $-$ signs are fairly evenly distributed, and, excluding the alcohols and acetic acid, the extreme values are -0.90 and $+1.00$. Again, for the simpler formula, the mean value of $\frac{\Delta'}{n}$, excluding the alcohols and acetic acid, is ± 10.54 , but for the formula with three constants it is only ± 0.43 . It is quite clear from this that the constants for the formula $D_t = D_0 + \alpha t$ calculated exclusively from the densities at temperatures below the boiling-point would in many cases differ very considerably from those calculated from the densities at temperatures above the boiling-point; and that the differences between the calculated critical densities $\{D_c = D_0 + \alpha(T_c - 273)\}$ and also between the values of α in the two cases might also be considerable.

Thus for normal octane the numbers would be

	D_0 .	α .	D_c .	α .
Below the boiling-point...	.3592	.000409	.2381	0.978
Above the boiling-point...	.3634	.000440	.2330	1.075

The constants calculated from the densities below the boiling-point approach fairly close to those obtained by M. Mathias for normal decane from the densities between 0° and 100° (p. 293) though, as might be expected from the higher molecular weight of decane and from the fact that the densities

were not taken even to the boiling-point, the errors in that case are still greater.

There seems to be no doubt that, in order to find the critical density with the greatest possible accuracy, it would be best to make use of the whole of the available data and to employ the formula with three constants, thus

$$D_c = D_0 + \alpha(T_c - 273) + \beta(T_c - 273)^2.$$

This has been done for the thirty substances, and the new and old critical densities, also the new values of $\frac{D_c}{D'_c}$, are given in Table IV.

For convenience of reference the critical temperatures and pressures, the specific gravities at 0° , and the boiling-points under normal pressure are also given in the table. The order is in ascending order of the recalculated values of $\frac{D_c}{D'_c}$.

It will be seen that the differences between the new and old critical densities are quite small. They are greatest for chlorobenzene, bromobenzene, and iodobenzene; but the critical temperatures of these compounds are very high, and the density determinations have only been taken to 260° or 270° . The greatest difference, that for iodobenzene, amounts to 0.55 per cent., and for this substance there is an extrapolation through 180° .

In the case of the alcohols the differences are not excessive because the old values were not obtained from the simple formula but graphically from curves drawn through the points representing the mean densities.

Of the remaining 26 substances benzene shows the greatest difference, 0.26 per cent.; in fourteen cases it is less than 0.1 per cent.

The alterations in the order of the substances in the tables (depending on $\frac{D_c}{D'_c}$) are few in number; di-isopropyl is brought next to isopentane; the four halogen derivatives of benzene are brought together, whereas in the old table bromobenzene was separated from the others; lastly, the new order of the alcohols is propyl, ethyl, methyl in place of ethyl, propyl, methyl.

In both tables the iso- and di-isocompounds have lower values of $\frac{D_c}{D'_c}$ than the corresponding normal compounds.

It is perhaps worth remarking that if, in the formula $\alpha = \frac{\alpha T_c}{D_c}$, we take the value of α in the formula with three

TABLE IV.

Name.	Sp. Gr. at 0°.	B.-P. at 760 mm.	Critical Temperature.	Critical Pressure.	Critical Density.		$\frac{D_c}{D_0}$ Corrected.
					Old.	Corrected.	
Carbon Tetrachloride	1.62255	76 ^o .75	288.15	millim.	5569	5576	3.674
Hexamethylene79675	80.9	280.0	34180	.2738	.2735	3.706
Isopentane63930	27.95	187.8	30250	.2344	.2343	3.732
Di-isopropyl67948	58.1	227.4	23345	.2410	.2411	3.742
Stannic Chloride	2.27875	114.1	318.7	28080	7.404	7.419	3.744
Benzene.....	.90006	80.2	288.5	36395	.3037	.3045	3.750
Normal Pentane64539	36.3	197.2	25100	.2324	.2323	3.750
Iodobenzene	1.86059	188.45	448.0	(33910)	.5846	.5814	3.763
Chlorobenzene	1.12786	132.0	360.0	33910	.3670	.3654	3.777
Fluorobenzene	1.04653	85.2	286.55	33910	.3542	.3541	3.790
Bromobenzene	1.52182	156.0	397.0	(33910)	4.879	4.853	3.799
Di-isobutyl71021	109.2	276.8	18660	.2369	.2366	3.808
Ether.....	.73620	34.6	194.4	27060	.2624	.2622	3.811
Normal Hexane67696	68.95	234.8	22510	.2344	.2341	3.829
Normal Heptane70048	98.4	266.9	20415	.2344	.2344	3.855
Methyl Isobutylate91131	92.3	267.55	25750	.3017	.3012	3.862
Normal Octane.....	.71848	125.8	296.6	18730	.2331	.2332	3.843
Propyl Formate92868	80.9	264.85	30440	.3095	.3093	3.868
Ethyl Formate94802	54.3	235.3	35590	.3232	.3232	3.885
Methyl Propionate93871	79.7	257.4	30030	.3123	.3124	3.904
Methyl Butyrate92006	102.75	281.25	26000	.3003	.3002	3.905
Ethyl Propionate91240	99.0	272.9	25210	.2969	.2965	3.912
Methyl Formate	1.00319	31.9	214.0	43030	.3494	.3489	3.926
Propyl Acetate.....	.91016	101.55	276.2	25210	.2964	.2957	3.934
Methyl Acetate95932	57.1	233.7	35180	.3255	.3252	3.942
Ethyl Acetate92436	77.15	250.1	28880	.3081	.3077	3.944
Propyl Alcohol81930	97.4	293.7	38120	.2752*	.2734	3.965
Ethyl Alcohol80625	78.3	243.1	47850	.2750*	.2755	4.024
Methyl Alcohol81020	64.9	240.0	59760	.2705*	.2722	4.549
Acetic Acid	1.06970	118.5	321.6	43400	.3511	.3506	4.986

* Critical density not calculated from formula $D_c = D_0 + \alpha t$, but read from curve constructed graphically.

constants instead of in that with two, and if we exclude the alcohols and acetic acid, the variation in a is much smaller than before, the extreme values being $\cdot 916$ and $1\cdot 039$ as against $\cdot 882$ and $1\cdot 090$, and the change is especially marked in the case of the hydrocarbons, for which the new constants range from $\cdot 916$ to $\cdot 968$ as against $\cdot 882$ to $1\cdot 075$. Now α in the formula $D_t = D_0 + \alpha t + \beta t^2$ differs but little from what it would be in the formula $D_t = D_0 + \alpha t$ if we were to take only the densities below the boiling-point, and as the variation of a is smaller in this case, it is the more remarkable that this constant should be so very low ($\cdot 7675$) for chlorine.

In this respect chlorine resembles the alcohols ($a = \cdot 717$, $\cdot 746$, and $\cdot 844$), but the critical densities of the alcohols are abnormally high whilst that of chlorine appears to be very low. It would be of considerable interest if the densities of the saturated vapour of chlorine could be determined at high temperatures so that the values of α , a , and D_c could be ascertained with certainty, but the experimental difficulties would be very great.

GENERAL CONCLUSIONS.

1. The law of Cailletet and Mathias is very nearly, though in most cases not absolutely, true; it appears to be only strictly true when the ratio of the actual to the theoretical density at the critical point $\left(\frac{D_c}{D'_c}\right)$ has the normal value $3\cdot 77$.

2. The curvature of the "diameter" is generally smaller the nearer $\frac{D_c}{D'_c}$ approaches the normal value, and the nearer $a \left(= \alpha \frac{T_c}{D_c} \right)$ approaches the value $0\cdot 93$.

3. The curvature is in nearly every case in opposite directions according as $\frac{D_c}{D'_c}$ is greater or less than $3\cdot 77$, and as a is greater or less than $0\cdot 93$, and is such that in the formula $D_t = D_0 + \alpha t + \beta t^2$ β is positive when $\frac{D_c}{D'_c}$ is lower than $3\cdot 77$ and negative when it is higher, α being negative in every case.

4. The curvature is generally so slight that the critical density may be calculated from the mean densities of liquid and saturated vapour at temperatures from about the boiling-point to within a few degrees of the critical point by means of the simpler formula $D_t = D_0 + \alpha t$ with an error rarely

exceeding 0.25 per cent. and generally not exceeding 0.1 per cent.

5. If, however, the critical density be calculated from the mean densities at low temperatures (say below the boiling-point) only, the error may be considerable; in the case of normal decane it is probably between 5 and 6 per cent.

6. As has been pointed out by M. Guye (*Archives des Sciences Phys. et Nat.* 1894, series 3, vol. xxxi.) the law does not, as a rule, hold good at all for substances the molecules of which differ in complexity in the gaseous and liquid states.

APPENDIX.

Since this paper was written Mr. K. Tsuruta has kindly sent me a copy of his 'Thermodynamic Notes,' No. 10 (*Phys. Rev.* 1900, x, p. 116) in which he discusses the "law of straight diameter" as applied to benzene. The conclusion he arrives at is that whilst the mean densities obey the law "in quite a satisfactory manner" not only from 80° to the critical-point, but also from 80° down to the triple point, yet a more minute examination showed the so-called diameter "to consist of two nearly straight parts meeting somewhere near the temperature 180° C., or, more strictly, to be a curve whose curvature is so slight that it can be so described."

This conclusion is practically in agreement with that stated in this paper.

XXVIII. *On the Duties of Ether for Electricity and Magnetism.* By Lord KELVIN*.

[Continued from p. 198.]

§ 19. **I**N my paper published in the last number of the *Philosophical Magazine*, of which this is a continuation, I limited myself to a problem of mathematical dynamics; and merely suggested the possibility of finding in it an explanation of the fundamental difficulty in the *Undulatory Theory of Light* referred to in the first and last paragraphs (§§ 1, 18). The following communication is the substance of a supplementary statement relating to that paper given orally to the *Congrès International de Physique* at a meeting held in Paris last Wednesday (August 8).

§ 20. I now cannot resist the temptation to speak of efforts which occupy me to find proper assumptions for including something of the allied subjects mentioned in the foot-note on § 1.

* Communicated by the Author.

§ 21. For atoms of electricity, which, following Larmor, I at present call electrons, it inevitably occurs to suggest a special class of atoms not fulfilling the condition stated in lines 12-22 of § 5.

Thus a *positive electron** would be an atom which by attraction condenses ether into the space occupied by its volume; and a negative electron would be an atom which, by repulsion, rarefies the ether remaining in the space occupied by its volume. The stress produced in the ether outside two such atoms by the attractions or repulsions which they exert on the ether within them, would cause apparent attraction between a positive and a negative electron; and apparent repulsion between two electrons both positive or both negative.

§ 22. But these apparent attractions and repulsions would increase much more with diminished distance than according to the Newtonian law of the inverse square. This law, which we know from Coulomb and Cavendish to be true for electric attractions and repulsions, *cannot be explained by stress in ether* according to any known or hitherto imagined properties of elastic matter. But a very simple hypothesis, assuming action at distances, between different portions of ether, explains it perfectly. Consider two portions of ether occupying infinitesimal volumes V, V' , at distance D asunder. My hypothesis is that they repel mutually with a force equal to

$$\frac{(\rho - 1)V \cdot (\rho' - 1)V'}{D^2} \cdot \cdot \cdot \cdot \cdot \quad (16);$$

where ρ, ρ' denote the densities of the two portions of ether considered, and 1 is the natural density of undisturbed ether. This makes the force repulsion or attraction according as $(\rho - 1), (\rho' - 1)$ are of the same or of opposite signs; and zero if either is zero, (which means that ether of undisturbed natural density experiences neither attraction nor repulsion from any other portion of ether far or near).

§ 23. This closely resembles Aepinus' doctrine of the middle of the eighteenth century, commonly referred to as the "one-fluid theory of electricity"; but now, instead of electric fluid, we have "ether," an elastic solid pervading all space. According to our present hypothesis, similar electric atoms repel one another, and dissimilar attract; in virtue of *force* between each atom and the portion of ether within it, and mutual repulsion or attraction of these portions of ether

* It seems probable that this may be the *resinous* electrification, but it may possibly be the *vitreous*. It must be remembered that vitreous electrification has hitherto been called positive merely because it is it which is given by the "prime conductor" of the old ordinary electric machine.

with no contributive action of the ether in the space around them and between them.

§ 24. Stress in ether, being thus freed from the *impossible task of transmitting both electrostatic and magnetic force*, is (we may well imagine) quite competent to perform the simpler duty of transmitting magnetic force alone.

§ 25. Hitherto one seemingly insuperable obstacle against following up this idea to practical realization has been the greatness of the force in many well known cases of magnetic attraction between iron poles, whether due to steel magnets or electromagnets. Considering that in our most delicate experiments in various branches of science, ponderable bodies large and small are observed to be moved freely by forces of less than a thousandth of the heaviness* of a milligram, how can we conceive the ether through which they move to be capable of the stress required for the transmission of force between flat poles of an electromagnet amounting per square centimetre to more than two hundred † times the heaviness of a kilogram? This difficulty is annulled if we adopt the hypothesis which I have described to the Congrès (§ 2 above). We may now suppose the density of ether as great as we please, subject only to the limitation that it must not be so great as to disturb sensibly the proportionality of effective inertia to gravity in different kinds of matter, proved by Newton in his pendulum experiment, for lead, brass, glass, &c., and by his interpretation of Kepler's third law for the different planets of our system. Probably we might safely, if we wished it, assume the density of ether to be as much as 10^{-6} . I am content at present, however, to suggest 10^{-9} . This, with the velocity of light 300,000 kilometres per second, makes the rigidity (being density \times square of velocity) equal to $9 \cdot 10^{11}$ dynes per square centimetre, which is somewhat greater than the rigidity of steel ($7 \cdot 10^{11}$). It is clearly not for want of strength that we need question the competence of ether to transmit magnetic force! I confess that I now feel hopeful of seeing solved some of the other formidable difficulties which meet every effort to explain electric insulation and conduction, and electromagnetic force, and the magnetic force of a steel magnet, by definite mechanical action of ether.

* I cannot without ambiguity use the simple word "weight" here; because this word means legally a mass, and is practically used more often to signify a mass than the gravitational heaviness of a mass.

† The most intense magnetic field hitherto measured is, I believe, that of Dubois (see his Report on Magnetism to this Congress) in which he found 76,000 c.g.s. between two small plane end-faces of soft iron poles of a powerful electromagnet. This makes the attraction per square centimetre of either face $(76,000)^2 \div 8\pi$, or approximately $23 \cdot 10^7$ dynes, or 230 kilograms.

XXIX. *An Appendix to the Paper on the Classes of Progressive Long Waves.* By R. F. GWYTHER, M.A.*

TO make a rigid test of the method of approximation which I have proposed in my paper on "The Classes of Progressive Long Waves" †, it appears to be desirable to pursue the investigation to a higher order of approximation, especially in the case of the Solitary Wave. For this purpose I continue the expansions in the paper referred to, in which

$$\left(c^2 - \frac{gh}{3}\right)k^2 f''' = -3cf'^2 + 2(c^2 - gh)f'$$

gave the first approximation.

From these terms we gather the mode in which the order of the terms is to be estimated; namely, that f' is of the order $(c^2 - gh)/c^2$, and f''' of the order $(c^2 - gh)^2/c^4$. I shall call, in order to avoid fractional orders, f' of the order 2 of small quantities, f''' of the order 3 ‡, and so on,

Acting on this principle, the terms of (3) of the previous paper (the equations in this paper are numbered continuously with those of the former) can readily be arranged in sets of orders 4, 6, and 8. We thus obtain

$$\begin{aligned} & \left(c^2 - \frac{gh}{3}\right)k^2 f''' \\ & - \frac{5c^2 - gh}{60}k^4 f^{iv} - \frac{gh^3}{c}f' f''' + k^2 f''^2 \\ + & \left[\frac{2(7c^2 - gh)}{7!}k^6 f^{vii} - \frac{2c^2 - gh}{12c}k^4 f' f^{iv} - \frac{ch^4}{3}f'' f^{iv} - \frac{c^2 + 2gh}{12c}k^4 f''^2 \right. \\ & \left. + k^2 f' f''^2 - \frac{2gh^3}{c^2}f'^2 f''' \right] \&c. \\ = & -3cf'^2 + 2(c^2 - gh)f' \\ & + f'^3 \dots \dots \dots (13) \end{aligned}$$

The character of the integrals of this equation to the 4th, 6th, and 8th orders are then seen to be as follows:—We shall be able to express in each case $2\left(c^2 - \frac{gh}{3}\right)k^2 f''^2$ in ascending powers of f' . The terms of the expansion will proceed as far as the third power in the solution to the 4th order; as far as the fourth power in the solution to the 6th order; and will extend to the fifth power in the solution to the eighth order;

* Communicated by the Author.

† Phil. Mag. August 1900.

‡ This was overlooked in forming the faulty solution (9).

to the fourth and also to the sixth order the general solution for f' will thus be in terms of elliptic functions; but this will cease to be the case to the eighth order. Having drawn these conclusions I shall now omit from (13) the terms (in square brackets) of the eighth order and proceed to the integration to the sixth order.

The solution gives

$$\begin{aligned}
 2\left(c^2 - \frac{gh}{3}\right)h^2 f''^2 &= A(c^2 - gh)^3 + B(c^2 - gh)^4 \\
 &- A \frac{15c^2 - 11gh}{5\left(c^2 - \frac{gh}{3}\right)^2} c(c^2 - gh)^3 f' \\
 &+ \left(4 + \frac{2}{15} \frac{(5c^2 - gh)(c^2 - gh)}{\left(c^2 - \frac{gh}{3}\right)^2}\right) (c^2 - gh) f'^2 \\
 &- \left(4 + \frac{2}{3} \frac{(5c^2 - gh)(c^2 - gh)}{\left(c^2 - \frac{gh}{3}\right)^2}\right) c f'^3 \\
 &+ 4f'^4 \dots \dots \dots (14)
 \end{aligned}$$

The presence of two constants in this equation is rather apparent than real; for if we take $\mu \frac{c^2 - gh}{c}$ for the value of f' which makes f'' vanish, we can find both A and B in terms of μ . Thus

$$A = \frac{4\mu^2(\mu - 1)}{c^2},$$

and the equation (14) may be written

$$\begin{aligned}
 2\left(c^2 - \frac{gh}{3}\right)h^2 f''^2 &= - \frac{4\mu^2(\mu - 1)(15c^2 - 11gh)}{5c\left(c^2 - \frac{gh}{3}\right)^2} (c^2 - gh)^3 \left\{f' - \frac{\mu(c^2 - gh)}{c}\right\} \\
 &+ \left(4 + \frac{2}{15} \frac{(5c^2 - gh)(c^2 - gh)}{\left(c^2 - \frac{gh}{3}\right)^2}\right) (c^2 - gh) \left\{f'^2 - \frac{\mu^2(c^2 - gh)^2}{c^2}\right\} \\
 &- \left(4 + \frac{2}{3} \frac{(5c^2 - gh)(c^2 - gh)}{\left(c^2 - \frac{gh}{3}\right)^2}\right) c \left\{f'^3 - \frac{\mu^3(c^2 - gh)^3}{c^3}\right\} \\
 &+ 4 \left\{f'^4 - \frac{\mu^4(c^2 - gh)^4}{c^4}\right\} \dots \dots \dots (15)
 \end{aligned}$$

The solution of this equation would give the general motion of a progressive long wave, and would allow us to determine the permissible values of μ . After putting $f' = \frac{\mu(c^2 - gh)}{c} + \frac{1}{z}$, we obtain an equation which would perhaps be most conveniently treated by Weierstrass's notation, since the factors on the right-hand side are far from obvious. We should be entitled to put $c^2 = gh$ in the coefficients of the small terms in order to make the expressions simpler. If $c^2 = gh$ exactly, the constant would have to be treated differently. As, however, my present object is to examine the nature of the approximation which has led to the differential equation, I shall confine the further integration to the case where $\mu = 0$, which leads to the case of the solitary wave. In the case of this wave we are able not only to compare our results with the analysis of earlier mathematical investigations, but also with the records of Scott Russell's careful observations.

Putting $\mu = 0$ in (15) we obtain

$$2 \left(c^2 - \frac{gh}{3} \right) h^2 f'^2 = \left(4 + \frac{2}{15} \frac{(5c^2 - gh)(c^2 - gh)}{\left(c^2 - \frac{gh}{3} \right)^2} \right) (c^2 - gh) f'^2 - \left(4 + \frac{2}{3} \frac{(5c^2 - gh)(c^2 - gh)}{\left(c^2 - \frac{gh}{3} \right)^2} \right) c f'^3 + 4 f'^4.$$

The first approximation being $f' = \frac{c^2 - gh}{c} \operatorname{sech}^2 mx$, where $m^2 h^2 = (c^2 - gh) / 2 \left(c^2 - \frac{gh}{3} \right)$, we are guided to the form of the second approximation, namely,

$$f' = p \frac{\operatorname{sech}^2 mx}{1 - q \tanh^2 mx}, \dots \dots \dots (16)$$

where

$$m^2 h^2 = \frac{c^2 - gh}{2 \left(c^2 - \frac{gh}{3} \right)} \left(1 + \frac{(5c^2 - gh)(c^2 - gh)}{30 \left(c^2 - \frac{gh}{3} \right)^2} \right), \dots (17)$$

$$p = \frac{c^2 - gh}{c} \left(1 + \frac{c^2 - gh}{c^2} - \frac{2(5c^2 - gh)(c^2 - gh)}{15 \left(c^2 - \frac{gh}{3} \right)^2} \right),$$

and

$$q = \frac{c^2 - gh}{c^2}.$$

From this the form of f is easily found; but the point of most interest is the relation between m and the parameters c and h given by (17).

The method of comparison which I am now about to make was very kindly suggested to me by Sir George Stokes, and is based upon the article communicated by him to Professor Lamb, which appears on p. 421 of the latter's 'Hydrodynamics.'

In that article the formula $c^2 = gh \frac{\tan 2mh}{2mh}$ is shown by a simple method to be the necessary relation between m and the parameters in the outskirts of a solitary wave. This result follows from assuming

$$\phi = A e^{-2m(x-ct)} \cos 2my$$

as the form of the velocity-potential when x is large.

Sir George Stokes has now pointed out to me that this is an *exact* relation provided we admit (1) the possibility of the uniform propagation of the disturbance as a solitary wave, and (2) that in such a wave, at a great distance from the crest, the coefficient of disturbance varies in geometric progression as the distance from the crest increases in arithmetical progression.

If then we admit that $c^2 = gh \tan 2mh/2mh$ is the exact formula for the wave, being found without assuming any relation between c and gh ; and if also the conditions of surface pressure can only be everywhere satisfied provided

$$m^2 h^2 = \frac{c^2 - gh}{2 \left(c^2 - \frac{gh}{3} \right)} \left\{ 1 + \frac{(5c^2 - gh)(c^2 - gh)}{30 \left(c^2 - \frac{gh}{3} \right)^2} \right\},$$

approximately, the approximate identity of the two formulæ forms the condition for the existence of a Solitary Wave of a certain amplitude. And as under proper restrictions we know that such a wave is capable of propagation, the comparison of the relations under these circumstances is the proper test of the justness of this mode of treatment.

So long as mh is small, we can easily make the comparison by writing the exact formula in the expanded form

$$\frac{gh}{c^2} = 1 - \frac{4m^2 c^4}{3g^2} + \frac{16m^4 c^8}{5g^4} \dots,$$

and substituting in the approximate expression. The expressions are then found to agree identically as far as these three terms in the expansion are concerned.

Proceeding to consider the larger values of mh , to which this expansion for $\frac{gh}{c^2}$ becomes inapplicable; Scott Russell's observations led him to the conclusion that the height of the solitary wave might be increased until it became about equal to the depth of the undisturbed fluid; and he gives $c^2 = 2gh$ as the empirical formula for the velocity in this case. Making a comparison of the formulæ again with this value for c^2 , the exact formula gives $\tan 2mh = 4mh$, and

$$mh = \cdot 583, \text{ approximately.}$$

The approximate formula in this case gives

$$mh = \cdot 577, \text{ approximately;}$$

so that, even in this extreme case, the formulæ are in very close agreement, the difference in the values of mh being just over 1 per cent.

This comparison seems fully to justify the use of the method I have employed to obtain the approximations.

As the first approximation is that most likely to be employed, it is perhaps worth while to record that the exact and approximate expressions for the relation between m and the parameters are identical for small values of mh if two terms are taken in the expansion for gh/c^2 , and that the difference in the terms of the next order is $2m^4c^8/5g^4$. Taking the extreme case when $c^2 = 2gh$, the approximate value of mh falls short of the exact value by about 7 per cent.

XXX. *The Chemical and Geological History of the Atmosphere.* By JOHN STEVENSON, M.A., F.I.C.*

I.—*The History of Free Oxygen.*

THE question as to whether any notable change has taken place in the chemical composition of the atmosphere in the course of geological history is one that has received a considerable amount of attention from chemists and geologists, though probably not so much as the importance and interest of the subject deserve. It has been sufficiently clear to geologists for many years that the carbon of our coal supplies has been derived from carbonic acid formerly diffused through the atmosphere or dissolved in the ocean; and that if all this carbonic acid existed at one time in the atmosphere, the atmosphere must have been very much richer in carbonic

* Communicated by Prof. G. F. FitzGerald, F.R.S.

acid then than it is now. Further, as the dissociation of carbonic acid by vegetation not only has for its result the fixation of carbon in the vegetable tissues, but also involves the liberation of oxygen, it is obvious that the deposition of the earth's supply of coal implies that a corresponding quantity of oxygen has become permanently free, and therefore the atmosphere must be to that extent richer in oxygen than it was before the coal was deposited. But, on the other hand, large quantities of oxygen are consumed and large quantities of carbonic acid are produced by respiration and combustion, and, also, very large quantities of carbonic acid are observed to issue from the earth in volcanic districts; so it is not at all surprising to find that some chemists have been of the opinion that the proportion of carbonic acid in the atmosphere is increasing, and that the proportion of oxygen is decreasing. In fact there has been, and probably there still is, a very great divergence in the opinions held on this question. And it is a question of the very greatest interest and importance to chemical and geological science, for even comparatively slight changes in the composition of the atmosphere, especially as regards the amounts of oxygen and carbonic acid present, would greatly affect the development of animal and vegetable life; while if such changes were at all considerable they would exert a powerful influence on many other phenomena, such as the weathering and denudation of rocks, the solution and precipitation of carbonates and hydrated oxides, and also the colouring of rocks and soils by iron compounds, which are very sensitive to oxidizing and reducing influences, and vary in colour accordingly.

Further, the very existence of such a large quantity of oxygen in the free condition as we find present in the atmosphere, notwithstanding its very strong affinities for other elements, presents a sufficiently striking scientific problem. No doubt a ready solution of it is sometimes found in the great abundance of oxygen on the earth generally, but this solution is by no means a satisfactory one. It would, no doubt, be satisfactory and sufficient if the materials composing the earth were all thoroughly oxidized. If that were the case, then the free oxygen of the atmosphere would be simply the extra or surplus oxygen that was left over after the requirements of the other elements were satisfied. But, unfortunately for this view, the earth, or at any rate the crust of the earth, is very far from being thoroughly oxidized. Not only do we find coal and other carbonaceous matter diffused throughout sedimentary rocks, but there are also found large quantities of sulphur, sulphide of iron and other

sulphides, and even in very primitive rocks the presence of oxidizable matter has been observed.

Probably the first chemist who pointed out this circumstance clearly, and based a theory of the history of the atmosphere upon it, was Prof. C. J. Koene, of Brussels, the contemporary and rival of Stas. In 1856, or thereabouts, he published a short series of popular lectures in which he enunciated the theory that there was no oxygen in the earth's primeval atmosphere, his reason for adopting this view being that oxidizable matter is found in the earth's primitive rocks. He held that the earth's primitive atmosphere consisted of nitrogen, carbonic acid, and aqueous vapour; and he also considered that the proportion of oxygen in the atmosphere had gone on increasing during geological history, while the proportion of carbonic acid and of nitrogen had gone on decreasing. In holding such views he differed very notably from previous and contemporary chemists, for example, Dumas and Liebig, who considered that the proportions of carbonic acid and of oxygen in the atmosphere were fixed and constant; and still more from Berzelius and Mulder, who were of opinion that the proportion of carbonic acid was increasing and the proportion of oxygen decreasing in the atmosphere, owing to respiration, fermentation, volcanic action, and human industry.

These statements about Prof. Koene are derived from an interesting series of articles which appeared in the 'Chemical News' at intervals during 1893 and 1894 (vols. 67, 68, 69, 70), and were written by Dr. T. L. Phipson, F.C.S., who had himself studied chemistry under Koene at Brussels. In these articles he describes Koene's views on the history of the atmosphere, and then proceeds to give certain modifications and additions of his own. In particular, he thinks that the constituents of the primitive atmosphere may quite well be reduced to the element of nitrogen alone, as he considers that the carbonic acid present at any time on the surface of the earth would be practically all dissolved in water. He thinks that carbonic acid was produced regularly and steadily throughout geological history by volcanic action, but also (apparently) that there was never a very large quantity of it existing on the earth in the free state at any one time, as it was constantly being decomposed by vegetation into free oxygen and the carbon of vegetable matters and of (ultimately) coal.

Dr. Phipson confirmed and amplified his views by a number of beautiful and interesting experiments on the growth of vegetation in various gases instead of ordinary air.

The results obtained were very striking and important, both as regards the way in which plants were found to thrive under very unusual conditions, and also the very great difference that was found to exist between different kinds of vegetation as regards their rate of producing oxygen; that is to say, the amount of oxygen produced by the same or similar weights of different kinds of plants in the same time and under similar conditions. As regards the experiments with gases, a most remarkable result was obtained in the case of hydrogen gas. The plant grew perfectly well, being of course at the same time supplied with carbonic acid in aqueous solution and with the elements of a fertile soil; but in the course of the experiment the hydrogen entirely disappeared. Dr. Phipson considered that it must have combined with the nascent oxygen produced by the decomposition of carbonic acid by the vegetation under the influence of light. He also infers from the same experiment that there was no free hydrogen in the earth's primitive atmosphere; but this inference is surely much more than is warranted by the facts observed. It would no doubt be fair enough to infer that if there was vegetation growing in very ancient times in an atmosphere containing hydrogen gas, the oxygen liberated from carbonic acid by the vegetation would not remain permanently free so long as there was any free hydrogen left. But vegetation may quite well have continued to grow in an atmosphere containing hydrogen until all the hydrogen had disappeared through combining with the oxygen produced by the vegetation, and after that time the oxygen liberated by vegetable growth would begin to have a chance of remaining permanently free.

The general interest taken in the question of the history of free oxygen has increased considerably within the last two or three years on account of the opinions expressed by Lord Kelvin in 1897. In that year he discussed the subject on two separate occasions, viz., in his address to the British Association in Toronto on the Fuel Supply and the Air Supply of the World, and in his address to the Victoria Institute, London, on the Age of the Earth*. In the former of these addresses (as briefly reported in 'Nature,' vol. lvi. p. 461) he argued that as the earth was in all probability originally hot and liquid, no primeval vegetable-fuel existed; further, no free oxygen existed at that period, since it is not found in gases evolved from minerals or in the spectra of stars. He considered, therefore, that the oxygen of the air has probably resulted from the action of sunlight

* *Phil. Mag.* January 1899.

on plants, and he found, by calculating the weight of fuel corresponding to the total free oxygen of the atmosphere, an upper limit to the amount of fuel in the world, viz. 340,000,000,000,000 (340 million million) tons.

However, in his address to the Victoria Institute on the Age of the Earth, his attitude on the oxygen question is much less definite and decided. In § 40 of the printed address he says that there is good reason for believing that there was no free oxygen in our primitive atmosphere, because the gases found in the cavities of granite and basaltic rock contain nitrogen, carbonic acid, and water, but no free oxygen. Further, some specimens of such rocks or minerals even contain free hydrogen, and when they do not contain free hydrogen they contain native iron or magnetic oxide of iron. He considers, therefore, "that we may judge that probably all the oxygen of the hot nebula which became the earth fell into combination with hydrogen and other metallic vapours on the cooling of that nebula; and though oxygen is known to be the most abundant chemical element on the earth, none of it was left out of combination to give free oxygen in our primitive atmosphere." His position here is obviously the same as that taken up in his Toronto address, but after discussing some other points connected with his general subject (the Age of the Earth), though not bearing directly on the free oxygen question, he goes on to say: "It seems improbable that the average of the whole earth—dry land and sea-bottom—contains at present coal or wood or oil or fuel of any kind, originating in vegetation to so great an extent as 0.767 of a ton per square metre of surface; which is the amount at the rate of one ton of fuel to three tons of oxygen that would be required to produce the 2.3 tons of oxygen per square metre of surface which our present atmosphere contains. Hence it seems probable that the earth's primitive atmosphere must have contained free oxygen." He adduces no other reason for this supposition than the above, viz., the difficulty in believing that there is so great an amount of fuel or combustible matter due to vegetation existing on the earth.

Probably most people will have the same difficulty in this matter that Lord Kelvin has, but still there is ample room to discuss the question further. The problem may be attacked in several ways with a fair degree of confidence or hopefulness in the obtaining of a satisfactory answer, or at least we may look at it from several standpoints, and thereby gain a clearer conception of its nature and scope.

The first and most obvious standpoint or line of inquiry

is that afforded by forming our estimate of the total coal-supply of the world, so far as this can be done from actual observation and measurement. Unfortunately the world has been so very imperfectly explored in this respect that the question as to the amount of the world's supply of coal is nearly (if not quite) as problematic as the question of the history of free oxygen. But still a good deal of information has been gained, and it is interesting to see in what direction it points.

The best-explored region of the world is probably the United Kingdom itself, and the best-known estimate of its coal-supply is that given by the Report of the Royal Commission on Coal, which sat from 1866 to 1871. In this report the "available coal," consisting of seams over one foot in thickness, and within 4000 feet of the surface, was estimated at 146,000,000,000 (146 thousand million) tons, while the coal at greater depths than 4000 feet was estimated at 48,000,000,000 (48 thousand million) tons. Since then Prof. Hull has given a much lower estimate of our coal-supply. He allows only 83,000,000,000 (83 thousand million) tons or so; but his reduction of the estimate seems to have been obtained principally by raising the limit of the workable thickness of coal-mines at considerable depths from one foot to two feet, as he thinks that seams less than two feet in thickness will not pay to work, even at depths considerably less than 4000 feet. But this question about the thickness of the seams does not at all affect our present inquiry. Even the seams under one foot in thickness, and carbonaceous or bituminous matters thinly distributed through shales, clays, limestones, &c., are of quite as great importance for our present purpose as the thickest and best deposits of workable coal. So far as I am aware no estimate of this thinly distributed carbonaceous matter has been published as yet, but it may possibly be much greater in amount than the total coal-supply itself, especially if we understand by the term coal only the seams that are at least one foot thick, and contain at least about 80 per cent. of combustible matter, that is to say, not more than 20 per cent. of ash. Let us suppose, however, that the total amount of this thinly distributed carbonaceous matter is equal to only half of the total quantity of coal over one foot in thickness. Let us also suppose that the Royal Commission's estimate of the total amount of coal at all depths in seams of one foot and upwards in thickness is fairly correct, and let us call it in round numbers 200,000,000,000 (200 thousand million) tons, as it comes pretty near that figure. This would make the coal in

seams less than one foot in thickness and other thinly distributed carbonaceous matter amount to 100,000,000,000 (100 thousand million) tons. The total amount of coal and other mineral carbonaceous matter in the United Kingdom would then be 300,000,000,000 (300 thousand million) tons. If we now suppose that the whole surface of the earth, whether dry land or covered by sea, contains on the average the same amount as the United Kingdom, then the total quantity on the earth will be $300,000,000,000 \times 1630$, or 489,000,000,000,000 (489 million million) tons—an amount which is practically equivalent to the total free oxygen of the atmosphere.

The total weight of the atmosphere is 5,200,000,000,000,000 (5200 million million) tons, as may be readily calculated from the data that it is equal to the weight of a layer of mercury 30 inches deep, or the weight of a layer of water 34 feet deep over the whole surface of the earth. And as 23 per cent. by weight of the atmosphere consists of free oxygen, the total free oxygen weighs very nearly 1,200,000,000,000,000 (1200 million million) tons. The amount of pure carbon that would be required to convert this quantity of oxygen into carbonic acid is 450,000,000,000,000 (450 million million) tons. Now if we suppose that the average amount of combustible matter in coal is equal to 90 per cent. of carbon (at least so far as its requirements of oxygen for combustion are concerned), then the amount of coal equivalent to the above figures would be 500,000,000,000,000 (500 million million) tons; a figure which is very similar to the estimate of the coal and other carbonaceous matter in the world which we have just made on the assumption that the amount present in the United Kingdom is something like the average for the whole world. It should also be noted that the above quantity is equal to a layer of coal $2\frac{1}{2}$ feet thick and of 1.3 specific gravity over the entire surface of the globe, or a layer 5 feet thick over the whole "continental" and "transitional" areas.

Of course the objections will be at once made that the United Kingdom is probably very much richer in coal than the rest of the world, and also that we should leave the water-covered areas out of account altogether in making such a calculation. As for the first objection, we can only say that it may be a strong and vital one, but we have no definite proof as yet. We may of course be quite sure that many large areas of the world are very much poorer in coal than the United Kingdom, but then again we know that other districts are very rich, perhaps even richer than the United

Kingdom; and if the world were better explored it is quite possible that many large areas might be found to be very much richer.

The second objection is undoubtedly a strong one, and probably applies with full force to the deep-ocean or abysmal areas, which cover about 50 per cent. of the earth's surface. But the "transitional" areas, covered by water less than 6000 feet deep, may quite well be included in our calculation, as they are regarded as coming within the sphere of ordinary geological change; that is to say, the alternation from dry land to sea-bottom and *vice versa*. At the very least they are not too far from the land (and what formerly was dry land) to contain thick strata of sedimentary rocks derived from the land by ordinary denudation, and they may therefore be expected to contain numerous rich deposits of coal. The continental and transitional areas are estimated to make up about 50 per cent. of the earth's surface; and if they contain as much coal and other carbonaceous matter as would be equivalent to the whole of our free oxygen, then obviously they must contain on the average double the amount that has just been estimated for the United Kingdom, or as much as would make a layer of coal 5 feet thick over their entire surface.

But, on the other hand, it is quite possible that the above estimate for the United Kingdom is much too low. The total amount of carbonaceous matter thinly distributed through many kinds of rock might be many times greater than that collected into thick seams of coal; and the same principle might apply to the rest of the world as well. In fact the proper way to state our question is to ask, not how much coal is there in the world (using the word coal in its ordinary acceptance), but what is the total amount of carbonaceous matter in the earth's crust? If we knew the percentage of carbonaceous matter in all geological formations, or if we simply knew the average percentage in a sufficient number of drill-cores, drilled to a sufficient depth all over the earth, we might be able to give a fairly good answer to the question. Many wells and bores have already been drilled to great depths in many parts of the world, but probably it is only in comparatively few cases that a definite or perhaps even an approximate answer could be given if the question were put as to what was the average percentage of carbonaceous matter in the whole depth of the bore. No doubt due note is taken of the general character of the rocks passed through, but that of itself can give only a very rough idea of the amount of carbonaceous matter present. I have

little doubt, however, but that in the drills or boring trials which have already been made in all parts of the world, to all degrees of depth and for all kinds of purposes, the average amount of organic or carbonaceous matter has been at least $\frac{1}{10}$ of a per cent. by weight. This is equal to a layer of coal 5 feet thick in each half-mile thickness of the earth's crust. It should be noted here that coal has only about half the specific gravity of other ordinary rocks, and therefore a layer of coal must be 5.28 feet thick in order to be equal in weight to a layer of ordinary rock of similar extent but only 2.64 feet in thickness—2.64 feet being $\frac{1}{10}$ per cent. of half a mile.

If we assume, then, that the total mass of existing sedimentary rocks on the earth is equal to a stratum of rock half a mile thick over the entire continental and transitional areas, and that it contains on the average $\frac{1}{10}$ per cent. of carbonaceous matter, then the total amount of such matter would be equal to a layer of coal 5 feet thick over these areas; and this, as we have already seen, would be practically equivalent to the total free oxygen of the atmosphere.

Also if, as is quite probable, the total mass of sedimentary rocks should be greater than the amount just supposed, then obviously the total amount of carbonaceous matter in the world would be even greater than the 500,000,000,000,000 (500 million million) tons which are required to be equivalent to our free oxygen. And so far as the percentage of carbonaceous matter is concerned, it is just as likely to be over as to be under $\frac{1}{10}$. Not only have we the coal itself, which alone might possibly reach up to that percentage, but there is the carbonaceous matter diffused through all kinds of shales, clays, slates, limestones, ironstones, &c. The proportion of organic or carbonaceous matter in these rocks is often $\frac{1}{2}$ per cent., and sometimes much more.

Of course if the total quantity of carbonaceous matter on the earth should be greater than 500,000,000,000,000 (500 million million) tons, it would exceed the upper limit laid down for it by Lord Kelvin, in the free oxygen of the atmosphere. But after all this consideration introduces no serious difficulty into the problem; at least it can be readily surmounted by the hypothesis that the primitive atmosphere of the earth not only contained no free oxygen, but that it contained a considerable quantity of free hydrogen or hydrocarbon gases. It is easy to see how the presence of these gases would affect the production of free oxygen by vegetation. If we assume that the primitive atmosphere of the earth contained also carbonic-acid gas, and that the primeval

vegetation grew in practically the same way as more recent vegetation, viz. through the decomposition of carbonic acid by sunlight—a process which involves the liberation of free oxygen; the oxygen at first liberated would not remain long in the free condition, because it would probably, as may be inferred from Dr. Phipson's experiment, soon combine with the hydrogen and hydrocarbon gases of the atmosphere to form water and carbonic acid. There would therefore be no permanent free oxygen so long as free hydrogen or hydrocarbon gases still remained in the atmosphere, and in the meantime a large amount of coal might have been deposited.

We admit that only indefinite results can be obtained as yet by the foregoing method of inquiry, but still they are definite enough to make a very high estimate of the total carbonaceous matter in the world quite credible and tenable. This view is also fairly well confirmed by studying the question from the standpoints provided by such general considerations as the length of geological time, the rate of deposition of sedimentary rocks, and the rate of the growth of vegetation.

We have now good reason to suppose that the formation of coal has been going on for the whole period of geological history which is recorded for us in sedimentary rocks. Though ordinary coal has not been found, so far as I am aware, in Cambrian and Laurentian rocks, graphite has been found in considerable quantity; and this points with a high degree of probability to the previous existence of ordinary bituminous coal. We also know that the deposition of coal was still going on in Tertiary times, and even now there is reason to believe that the process is going on to a not inconsiderable extent. If we therefore divide the total amount of coal by the number of years of geological time, we shall have the average rate of its annual production. No doubt estimates of the length of geological time vary very much. Lord Kelvin's estimate is that about 20,000,000 years have elapsed since the solidification of the earth's crust from the liquid condition, and also since the possible and probable beginnings of vegetable life. If, then, we divide 500,000,000,000 by the above figure, we obtain 25,000,000 tons as the average amount of coal that would have to be deposited annually during the whole of geological time, to give us an amount equivalent to the free oxygen of the atmosphere. And if we require, with certain biologists and geologists, a period of at least 680,000,000 years, the rate of production of coal becomes very much less, only about 740,000 tons per annum. These two estimates are no doubt widely divergent, but still even the larger one is quite a modest and credible figure, and

would still be so though it were multiplied several times in order to make allowance for coal that may have been destroyed by oxidation after its first deposition and consolidation. This latter is a point of some importance ; for though coal is not readily oxidized by the air at the ordinary temperatures, yet when organic matter is deposited in contact with oxide of iron and sulphate of lime, it is very liable to be oxidized, sulphide of iron being formed at the same time. Probably also, when rocks containing coal are highly heated by the irruption of igneous rocks, a quantity of the coal may be oxidized at the expense of the oxides with which it comes into contact. However, we need not take much account of such considerations at present, and we can say confidently enough that the presence of a quantity of coal in the earth equivalent to the whole of our free oxygen is not at all incredible when we have regard to the length of time during which the deposition has most probably been going on.

A similar verdict is obtained if we compare the rate of deposition required by the above calculations with the rate of deposition of the other rocks derived from the denudation of the earth as a whole. Estimates of the rate of denudation no doubt vary just about as much as estimates of the age of the earth ; but even if we take Darwin's estimate of 1 inch per century, which seems to be regarded as rather a low estimate, this would give us an annual denudation from the present land-surface of the earth of 85,000,000,000 (85 thousand million) tons of rock. This is equal to 3400 times the 25,000,000 tons of coal that would have to be deposited annually in order to give us 500,000,000,000,000 tons in 20,000,000 years ; or the average proportion of carbonaceous matter that would have to be present is only 0.03 per cent. This seems a modest enough figure when we remember the great amount of peat that is annually produced in many parts of the earth, and may be regarded as a geological deposit, and also the vast quantity of blue mud that is accumulating on the sea-bottom within the first few hundred miles from land. Analyses of this mud would be very useful if they were available, but at any rate it must contain, or must have at first contained, sufficient organic matter to change a considerable amount of oxide of iron and sulphate of lime (the latter being derived from sea-water) into sulphide of iron and carbonate of lime.

There is no doubt a difficulty in this line of reasoning, due to the obvious circumstance that as new strata are being deposited, old ones are worn down and washed away ; but probably this difficulty is not so great as it looks at first. Coal and other bituminous matters are only very slowly, and

perhaps never completely, oxidized by air at the ordinary temperature, and therefore when old coal-bearing strata are washed away, the bulk of the old carbonaceous matter may still help to increase the percentage in the new deposits. However, even if we should have to make a liberal allowance for the destruction of old carbonaceous matter by oxidation in some way or other, the results obtained by this line of inquiry are not unfavourable to the credibility of a high estimate of the world's supply of fuel, for all the elements in the above calculation, required to give us 500,000,000,000,000 tons of coal, viz. (1) the amount of rock annually denuded and again deposited (85,000,000,000 tons), (2) the length of time that this denudation has been going on (20,000,000 years), and (3) the proportion of organic matter present (0.03 per cent.), are more likely, taken as a whole, to err on the side of being estimated too low than of being estimated too high.

[To be continued.]

XXXI. *The Motion of a Sphere in a Viscous Fluid.*

By H. S. ALLEN, M.A., B.Sc.*

I.

1. Theoretical Formula of Stokes,

$$V = \frac{2}{9} \frac{\sigma - \rho}{\rho} \cdot g \frac{a^2}{\nu}$$

2. Steady Flow in a Uniform Tube.

3. Law of Resistance to the Movement of a Sphere in Sinuous Motion.

II.

4. Motion of a Fluid Sphere.

5. Observations of the Terminal Velocities of Small Bubbles.

6. Observations of the Terminal Velocities of Small Solid Spheres.

7. Conclusions from these Observations,

$$V = k \left(\frac{\sigma - \rho \cdot g}{\rho} \right)^{\frac{2}{3}} \frac{a - h\bar{a}}{\nu^{\frac{1}{3}}}$$

III.

8. Photographic Method of Determining Velocities.

9. Accelerated Motion of the Falling Sphere.

10. Terminal Velocity of the Falling Sphere.

11. Law of Resistance,

$$R = k\rho a^2 V^2.$$

12. Fall of an Oiled Sphere.

13. Summary and Conclusion.

I.

1. *Theoretical.*

THE motion of a solid sphere falling freely under gravity in a viscous fluid has been investigated theoretically by Stokes †. The sphere will attain a constant terminal velocity

* Communicated by Prof. J. J. Thomson, F.R.S.

† Camb. Phil. Trans. vol. ix. 1850.

when the effective weight is equal to the resistance consequent on the viscosity of the fluid. In the case of very slow motion this resistance is

$$6\pi\mu aV \frac{\beta a + 2\mu}{\beta a + 3\mu},$$

where V is the constant velocity,
 a is the radius of the sphere,
 μ is the coefficient of viscosity of the liquid,
 β is the coefficient of sliding friction.

Equating this to the effective weight $\frac{4}{3}\pi g(\sigma - \rho)a^3$, we obtain for the limiting velocity

$$V = \frac{2}{9}ga^2 \frac{\sigma - \rho}{\mu} \frac{\beta a + 3\mu}{\beta a + 2\mu},$$

where σ is the density of the sphere, and ρ is the density of the liquid.

This equation only holds good when the velocity is so small that squares may be neglected. Those terms in the equations of motion of the fluid which represent its inertia are neglected in comparison with those due to its viscosity*. Consideration of these terms shows that $V\rho a$ must be small compared with μ . Or if we write $\mu = \nu\rho$, so that ν is the kinematic coefficient of viscosity, Va must be small compared with ν .

We may call that value of a which makes $Va = \nu$ the "critical radius." Denoting it by \bar{a} , we find

$$\bar{a}^3 = \frac{9\mu^2}{2g\rho(\sigma - \rho)} \frac{\beta\bar{a} + 3\mu}{\beta\bar{a} + 2\mu}.$$

Both the terminal velocity and the critical radius involve the coefficient of sliding friction β . The value of the fraction $\frac{\beta a + 3\mu}{\beta a + 2\mu}$ lies between 1 and $\frac{3}{2}$, as β varies from infinity (no slipping) to zero (infinite slip). Whetham† has shown that for steady flow through a capillary tube no slipping occurs at the surface of separation of solid and liquid.

In the case in which β is infinite, to which therefore the greatest interest attaches,

$$V = \frac{2}{9}ga^2 \frac{\sigma - \rho}{\mu},$$

$$\bar{a}^3 = \frac{9\mu^2}{2g\rho(\sigma - \rho)}.$$

* Lamb, 'Hydrodynamics,' p. 533; Lord Rayleigh, Phil. Mag. (5) xxxvi. pp. 364-365, 1893 (2).

† Phil. Trans. clxxxi. (A) pp. 559-582 (1890).

The small value of the critical radius in all practical cases renders the direct verification of the formula for the terminal velocity difficult. For a particle of sand falling through water at 15° C. ($\mu = \cdot 0115$), taking $\sigma = 2\rho$, the critical radius is $\cdot 0085$ centim. Unless the radius of the particle is smaller than this, the solution founded upon the type of infinitely slow motion is inapplicable.

2. Steady Flow in a Uniform Tube.

In considering the motion of a sphere through a viscous fluid it is instructive to recall the results arrived at in the somewhat analogous case of the flow of a viscous fluid through a uniform pipe or channel. When the motion is steady, the accelerating force must be exactly balanced by the resistance due to fluid viscosity.

If the flow is rectilinear, the hydraulic gradient—that is the fall in pressure per unit length of the tube—is proportional to the first power of the mean velocity.

Hagen* and Reynolds† have shown independently that rectilinear flow is only possible in practice when the velocity is less than a certain maximum amount, the “critical velocity,” depending on the radius of the tube and the viscosity and density of the fluid. When the velocity exceeds this value the flow becomes turbulent.

The existence of a definite critical velocity has been questioned. According to Lord Kelvin’s view‡ the steady motion of a fluid is theoretically stable for infinitely small disturbances for any viscosity however small. This stability may not extend beyond very narrow limits; so that in practice under finite disturbances the motion would be unstable except for sufficiently viscous fluids.

This view has been criticized by Lord Rayleigh in a paper “On the Question of the Stability of the Flow of Fluids”§.

Practically, at least, we seem justified in accepting the idea of a critical velocity at which eddying motion begins.

The law of resistance in the turbulent régime has been investigated by several observers||. The results may be expressed by taking the hydraulic gradient proportional to

* *Abhandl. Akad. Wiss. Berlin*, 1854, Math. Abt. pp. 17.

† *Phil. Trans.* clxxiv. pp. 935–982 (1883).

‡ *Phil. Mag.* (5) xxiii. pp. 459–464, 529–539 (1887); xxiv. pp. 188–196, 272–278, 342–355 (1887).

§ *Phil. Mag.* xxxiv. pp. 59–70 (1892).

|| A convenient summary and discussion of these results may be found in a paper by G. H. Knibbs, *Proceedings Roy. Soc. N. S. W.*, xxxi. pp. 314–355 (1897).

some power of the velocity, the index having a value between 1.7 and 2, depending on the material of the pipe.

3. *Law of Resistance to the Movement of a Sphere when the Motion is Sinuous.*

When the velocity of the sphere moving uniformly in an infinite fluid becomes so great that eddying motion is set up, we have no means of determining theoretically the way in which the resistance varies. In the parallel case of the flow of liquids through pipes the empirical results show that the resistance may be taken proportional to some power of the velocity. *If we assume* that the resistance, R , to the motion of a solid sphere may in like manner be taken proportional to V^n , so that it may be represented by a single term,

$$R = ka^x \rho^y \nu^z V^n,$$

we may employ the principle of dynamical similarity to determine the form of the indices x , y , z .

The corresponding "dimensional" equation is

$$\frac{ML}{T^2} = L^x \left(\frac{M}{L^3}\right)^y \left(\frac{L^2}{T}\right)^z \left(\frac{L}{T}\right)^n.$$

Since the quantities M , T , and L must occur to the same degree on both sides of this equation, we must have

$$\begin{cases} y = 1, \\ z + n = 2, \\ x - 3y + 2z + n = 1, \end{cases}$$

yielding

$$\begin{cases} y = 1, \\ z = 2 - n, \\ x = n. \end{cases}$$

Thus

$$\begin{aligned} R &= ka^n \rho \nu^{2-n} V^n \\ &= k \rho \nu^{2-n} (aV)^n. \end{aligned}$$

When the sphere has attained its terminal velocity, the effective weight is exactly balanced by the fluid resistance. If V now represent this terminal velocity,

$$k \rho \nu^{2-n} (aV)^n = \frac{4}{3} \pi g (\sigma - \rho) a^3;$$

and therefore V is proportional to

$$a^{\frac{3}{n}-1} / \nu^{\frac{2}{n}-1}.$$

The theoretical result given by Stokes for the case of very slow motion is obtained by putting $n=1$ and the constant $k=6\pi$. Then the resistance is $6\pi\rho\nu aV$, and the terminal velocity = $\frac{2}{9} \frac{(\sigma-\rho)g}{\rho} \frac{a^2}{\nu}$.

If n were equal to $\frac{3}{2}$, the terminal velocity would be proportional to the first power of the radius.

If n were equal to 2, the square of the terminal velocity would be proportional to the radius, and *the resistance would be independent of the viscosity*; while, if it were possible for n to be greater than 2, the resistance would increase as the fluidity increased.

II.

4. Motion of a Fluid Sphere.

The present investigation was commenced, at the suggestion of Prof. J. J. Thomson, to see whether the velocity acquired by small bubbles of gas ascending through a liquid would conform to the theoretical result for a solid sphere, and, if possible, to derive some information as to the existence of sliding friction in this case.

The question of the applicability of the formula to the motion of a liquid sphere has already been discussed in a paper read before the Physical Society by O. G. Jones *, who made a series of experiments in which globules of mercury were dropped through highly viscous fluids, and their velocities determined. He assumed that the globule might be treated as spherical, and that the coefficient β was infinite. Lord Rayleigh observed that there might be circulation within the globule; and Dr. Burton pointed out that with perfectly liquid spheres there would be infinite slip, and β would therefore be zero. Later experiments based on the same assumptions were made by A. W. Duff †, who employed the measurements of the velocities of mercury globules and small shot in glycerin or paraffin to detect any change in viscosity due to an electrostatic field.

If the fluid in the interior of a globule ascending or descending in a liquid is in circulation, the viscosity of the fluid of which the globule is composed must affect its velocity. But when the globule is a bubble of air, the internal friction is so small that its effect on the velocity may be safely neglected.

We have also to assume that when the bubble is sufficiently

* Phil. Mag. (5) xxxvii. pp. 452-462 (1894).

† Phys. Review, iv. pp. 23-38 (1896).

small, the surface-tension is great enough to keep its form sensibly spherical. Further, any effect due to the existence of waves on the surface has to be disregarded.

All these effects would have to be considered in a complete solution of the problem; but it appears certain that in the slow motion of a *small* bubble they would enter only as corrections to the velocity calculated for a solid sphere with a definite amount of slipping at the surface.

5. Method of determining the Velocity of Small Bubbles.

The apparatus used is shown in the diagram (fig. 1). A is a long glass tube whose bore is very large compared with the diameter of the bubbles observed. It is closed at the lower end by a cork through which pass two tubes, one serving to draw off the liquid, and the other to furnish the bubbles. This second tube ends within the receiver in a fine capillary tube, while outside it is connected with a pressure-tube containing mercury.

The method of procedure for the production of bubbles is as follows:—The pressure-tube, including the lower part of the T-piece, is filled with mercury, and the pinch-cock is closed. The capillary tube, made by drawing out one end of a short piece of clean tubing of the same bore as the T-piece, is securely attached to the upper end of the latter by a rubber joint. The cork is then inserted and the receiver filled with the liquid to be used. By raising the pressure-tube and opening the pinch-cock the air enclosed in the vertical limb of the T-piece is driven out in a stream of bubbles. The pressure-tube is lowered until this stream just ceases, and the pinch-cock is again closed. The pressure of the fingers on the rubber tube is then sufficient to form the bubbles when required. In this way single bubbles or groups of two or three can be detached at will. The bubbles are so small that the air enclosed is sufficient to produce a very large number; but if necessary more air can be introduced by lowering the pressure-tube and opening the clamp at the free end of the T-piece.

As the pressure employed in starting the bubbles is sometimes as much as an atmosphere, care must be taken to see that all joints are perfectly secure.

There is a considerable fascination in watching the formation and ascent of these bubbles. The smaller bubbles ascend with extreme steadiness; but when large bubbles are formed from a comparatively wide capillary they ascend in a spiral curve round the tube, and are seen to be in continual

oscillation. When two small bubbles come into contact during their ascent they sometimes rebound as if they were elastic spheres, and at other times coalesce to form a larger bubble. It is a common thing to see two bubbles of the same size ascending together, at a distance apart perhaps ten times the diameter of either, with the line joining their centres making an angle of 45° with the vertical.

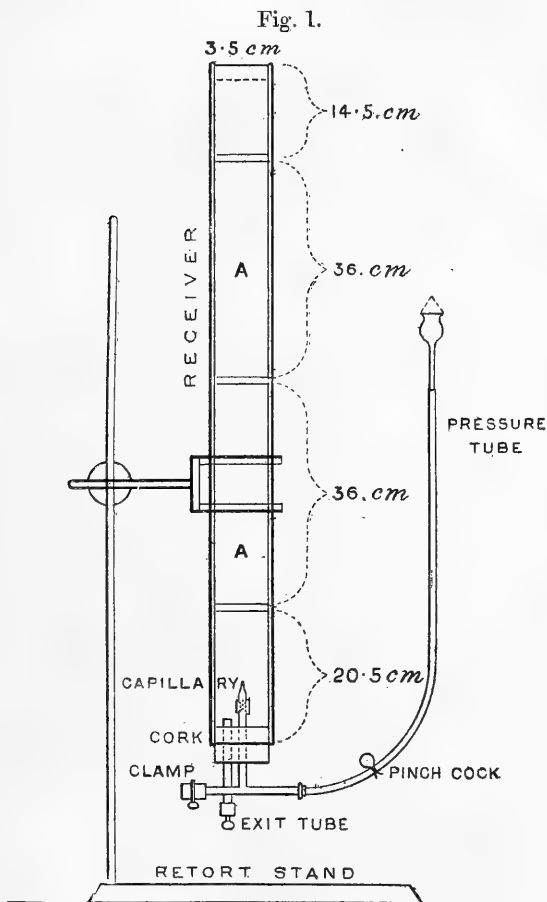

The behaviour of the different capillary tubes used presented some interesting features. With thick-walled tubes the bubbles produced were of practically the same size for any particular tube.

With very fine thin-walled capillaries the size of the bubble

depended to some extent on the pressure employed in separating it. Frequently, with such tubes, several bubbles were detached one after the other, those in front being larger than those behind. Some of these bubbles were so minute as to be only just visible. It is suggested that in these cases the larger bubbles were produced by the practically instantaneous formation of a number of the very minute bubbles.

The behaviour of one of these fine tubes would differ considerably at different times, no doubt in consequence of the particular state of cleanliness of the tube or the deposit of some minute particle. Thus a tube which had been giving a small cloud of fine bubbles would suddenly refuse to give anything but a much larger bubble of fairly constant size.

The terminal velocities of the bubbles were measured by observing the times of ascent through distances marked on the vertical tube. The times were taken with a stop-watch or chronometer.

It is necessary to measure the size of a bubble whose velocity has been determined. The simple arrangement shown in fig. 2 was constructed to catch the bubble at the

Fig. 2.

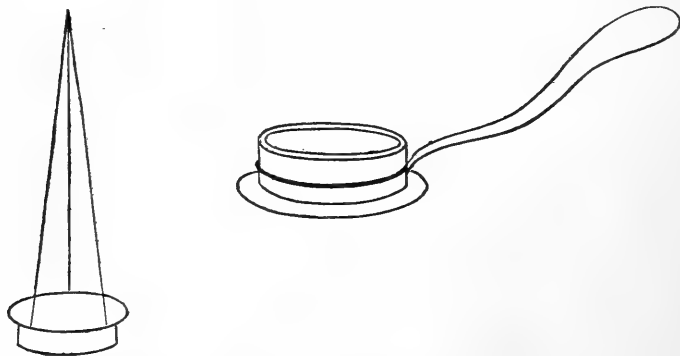

top of the tube, so that it might be removed to the stage of a microscope fitted with a micrometer eyepiece and measured. To two microscope cover-glasses, $2\frac{1}{2}$ centim. and $1\frac{1}{2}$ centim. in diameter respectively, were cemented with Canada balsam glass rings of rather smaller diameter.

The smaller cup thus formed was suspended, mouth downwards, in the top of the receiver by three silk fibres. When the bubble to be examined had entered from below, the larger cup was slipped underneath by means of a handle of wire, and the whole was lifted out and transferred to the stage of the microscope. The diameter of the bubble now in contact

with the lower surface of a cover-glass could be measured. The bubbles are so small that, although they are in contact with a plane glass surface, they may be considered spherical.

The following results make up the first complete set obtained, and are given for that reason only. The temperature was about 15° C., but was not specially noted. The velocities were determined by timing an ascent through 66 centim.

TABLE I.
Air-bubbles in Water.

Radius in centim. }	·0071	·0076	·0085	·0107	·0109	·0134
Velocity in cm. per sec. }	0·92	1·16	1·13	1·59	1·70	2·16
Radius in centim. }	·0141	·0180	·0233	·0256	·0381	·0385
Velocity in cm. per sec. }	2·59	3·14	4·40	4·80	7·89	7·47

In the last three observations recorded in the table the radius of the bubble was determined by collecting a large number of equal bubbles and finding the volume they occupied.

The results are plotted in fig. 3 (p. 332) with the radius as abscissa and the velocity as ordinate. In the same diagram are shown the theoretical results for a solid sphere falling through water at 15°, assuming $\sigma = 2\rho$. The parabola for which $\beta = \infty$ corresponds to the case of no slip, and that for which $\beta = 0$ to the case of infinite slip. The "critical" points are marked by stars.

It will be seen that the observed points lie on a straight line cutting the line of zero velocity not far from the origin. Hence

$$V = K(a - b)$$

where b is a small constant quantity.

For velocities greater than the critical velocity the terminal velocity of small bubbles is proportional to the radius diminished by a small constant.

If we employ the principle of dynamical similarity in the manner already illustrated, to determine the form of the quantity K , we obtain

$$V = k \left(\frac{\rho - \sigma}{\rho} \cdot g \right)^{\frac{2}{3}} \frac{a - b}{\nu^{\frac{1}{3}}}.$$

Fig. 3.

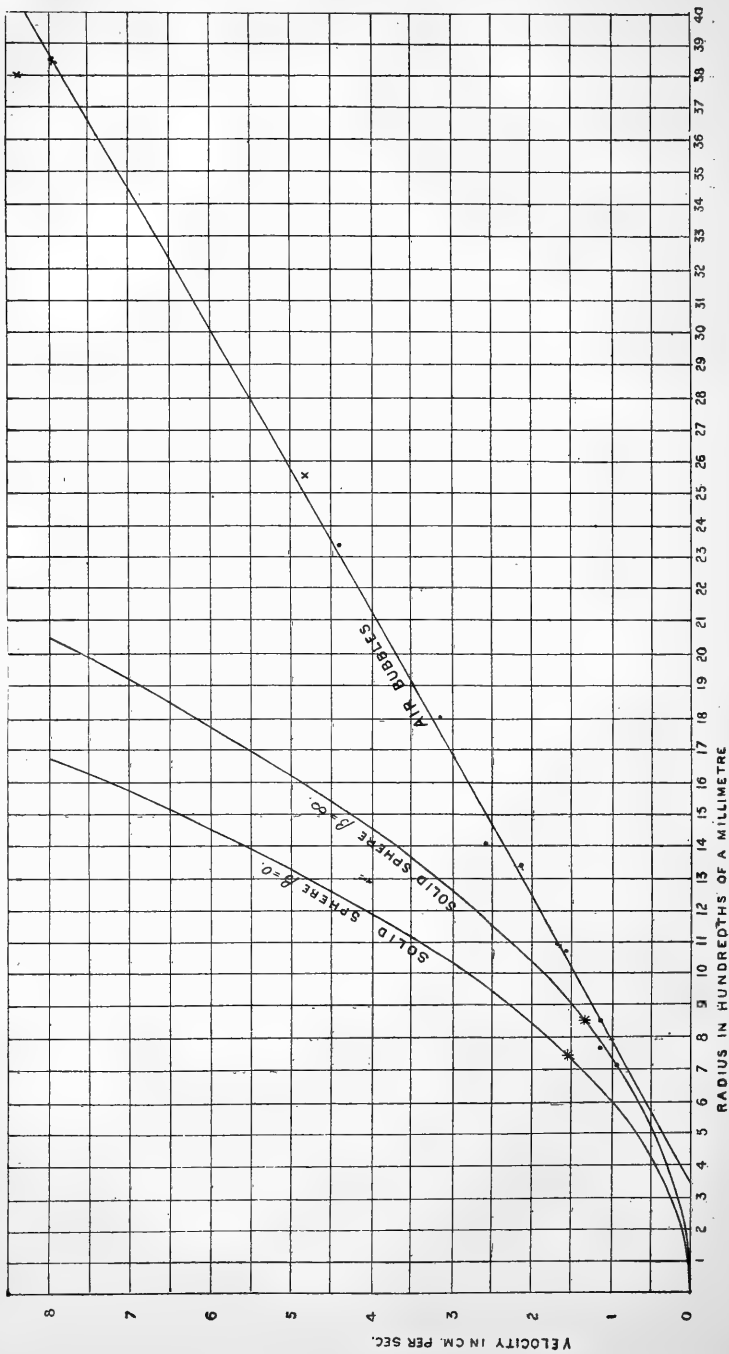

The value of the constant k must be $\cdot 518$ if the line drawn in the diagram is to be represented by the formula. We may simplify the result by assuming $k = \frac{1}{2}$, a course only justified by the fact that later observations agree sufficiently well with the simplified formula.

Again the constant b must be of the dimensions of a length. Now the only length available for comparison is the critical radius \bar{a} . Hence we may suppose b expressed as a certain fraction of the critical radius, whose value at 15° is $\cdot 0085$ centim. From the diagram we find $b = \frac{2}{3} \bar{a}$, nearly. Thus

$$V = \frac{1}{2} \left(\frac{\rho - \sigma \cdot g}{\rho} \right)^{\frac{2}{3}} \frac{\bar{a} - \frac{2}{3} \bar{a}}{\nu^{\frac{1}{2}}}$$

One difficulty in determining the velocity of a bubble by this method has not yet been alluded to. This arises from the fact that the volume of the bubble does not remain constant. Two causes will be active in changing the volume of a bubble of gas ascending through a liquid—the change in pre-sure and the gradual solution of the gas in the liquid. In the case of small bubbles the second cause generally predominates. Using ordinary distilled water it was found that for velocities greater than about 1 centim. per second there was practically no difference between the times for the first and second half of an ascent of 72 centim., but for velocities less than this the second half of the journey took longer than the first. Extremely small bubbles were dissolved before travelling the whole distance.

I sought to overcome this difficulty by bubbling air through the water used for a long period so as to get a saturated solution. However, the most satisfactory series of results was obtained on a day on which the temperature fell to about 8° C. and so gave rise to sufficiently complete saturation.

The results are given in Table II.

The calculated values for the velocity are given in two columns. In the first are the values calculated from the formula of Stokes (Parabolic formula), in the second are those found from the empirical relation given above (Linear formula). The critical radius, assuming $\nu = \cdot 01404$ at $8^\circ \cdot 4$ C., is equal to $\cdot 00967$ centim.

On comparing the calculated and observed results it will be seen that for bubbles less than the critical size the velocities tend to agreement with the theoretical values; for larger bubbles the velocities agree with those given by the linear formula.

TABLE II.

Air-bubbles in Water.

No. of Observation.	Temp.	Radius in cm.	Velocity in cm./sec.		
			Calculated 8°-4C.		
			Observed.	Parabolic Formula.	Linear Formula.
	° C.				
14.	8·6	·00471 *	·387	·345	·16
16.	8·5	·00570	·511	·505	·37
9.	8·4	·00632	·585	·620	·50
8.	8·4	·00719	·626	·802	·68
11.	8·5	·0097	1·26	1·46	1·22
13.	8·6	·0106	1·40	1·75	1·41
15.	8·5	·0109 †	1·45	1·46
10.	8·5	·0141	2·03	2·13
12.	8·6	·0144 *	2·18	2·21
7.	8·4	·0155	2·36	2·42
1.	7·6	·0170	2·67	2·73
5.	8·4	·0187	3·13	3·09
17.	8·4	·0190	3·20	3·15
4.	8·3	·0201	3·39	3·38
6.	8·4	·0206	3·35	3·47
18.	8·4	·0224	3·89	3·85
3.	7·9	·0241	4·23	4·19
2.	7·8	·0305	5·54	5·49

Although considerable time was spent in the endeavour to penetrate further into the region of non-sinuuous flow the small value of the critical radius in the case of water made it difficult to obtain results that were entirely satisfactory. It was therefore decided to employ a more viscous liquid for which the critical radius would have a greater value. For this purpose aniline was selected. Its coefficient of viscosity, as determined by Wijkander ‡ at 12° C., is ·06023 (about five times that of water at the same temperature) and its specific gravity (°/₀) is 1·038. The critical radius calculated from these values is ·0255 centim.

The experiments were carried out in the same manner as in the case of water. The numerical results are given in Table III.

* Group of three equal bubbles.

† „ „ two „ „

‡ Wied. Beibl. vii. p. 11 (1879).

TABLE III.
Air-bubbles in Aniline.

Temp.	Radius in cm.	Velocity observed. cm./sec.	Velocity calculated cm./sec.		Remarks.
			Parabolic Formula, 12° C.	Linear Formula, 12° C.	
° C.					
9.6	.00346	.082	.045	Group of three bubbles.
9.6	.00661	.171	.164		
9.8	.00690	.188	.179		
9.8	.00719	.202	.194		
9.6	.00719	.202	.194		Group of three bubbles.
9.6	.00750	.260	.212		
9.6	.00865	.355	.281	
11.6	.00977	.390	.359		
9.8	.0103	.372	.402	.04	} Formed by the union of two bubbles.
10.0	.0112	.453	.471	.16	
12.2	.0126	.615	.600	.34	
9.8	.0132	.657	.655	.42	
9.8	.0144	.727	.777	.56	
10.0	.0150	.750	.845	.65	
10.0	.0152	.69669	
10.7	.0164	.90685	
11.0	.0172	1.0093	
10.7	.0195	1.23	1.23	
10.7	.0201	1.33	1.31	} Formed by the union of two bubbles.
10.7	.0206	1.37	1.37	
10.0	.0210	1.37	1.43	} Formed by the union of two bubbles.
10.4	.0210	1.45	1.43	
10.7	.0213	1.45	1.46	
10.7	.0230	1.71	1.68	
10.0	.0259	2.00	2.05	} Formed by the union of two bubbles.
10.7	.0259	1.96	2.05	
10.4	.0265	2.09	2.12	
10.0	.0276	2.18	2.26	
10.4	.0276	2.18	2.26	} Formed by the union of two bubbles.
10.0	.0287	2.29	2.36	
11.8	.0330	3.00	2.93	} Formed by the union of two bubbles.
11.8	.0345	3.09	3.12	
11.0	.0351	3.43	3.21	} Formed by the union of two bubbles.
10.0	.0374	3.43	3.50	
12.0	.0535	6.00	5.56	} Formed by the union of two bubbles.
11.8	.0539	6.43	5.60	
12.0	.0552	6.00	5.77	

An inspection of this table shows that when the radius of the bubble is as great as one-half the critical radius the velocity agrees with that deduced on the assumption of parallel flow, supposing that no slipping occurs at the boundary. For bubbles of larger size the velocity agrees with that calculated by means of the empirical formula.

6. Terminal Velocities attained by Solid Spheres.

As long as we are restricted to comparatively small velocities, less for instance than 10 centim. per second, it is necessary to employ spheres of small radius, unless the density of the sphere is very nearly the same as that of the liquid. In the latter case great precautions must be taken to ensure the temperature remaining constant from place to place, and from time to time.

A series of experiments were made with spheres of pure paraffin, of specific gravity 0.907. The spheres were formed by melting a small piece of paraffin in a mixture of alcohol and water whose density was adjusted so as to be the same as that of the melted paraffin. On shaking the warm mixture the paraffin broke up into a large number of small globules which solidified without losing their spherical form. The most perfect spheres were selected for the experiments, and their diameters were measured under the microscope.

These spheres were allowed to rise in a wide tube inverted in a basin of liquid and filled by suction at the upper end.

The first experiments were made on paraffin spheres rising through water. As the water did not wet the spheres it was found impossible to avoid small air-bubbles clinging to them and travelling with them up the tube. Irregularities were thus introduced into the result which prevent great importance being attached to them. However, the observations when plotted are found to cluster round the line represented by the empirical formula.

Better results were obtained from experiments on the ascent of paraffin spheres in aniline, although in this case also care had to be exercised to prevent the presence of air-bubbles. The results are given in Table IV. The critical radius is about .051 centim.

In order still further to test the applicability of the formula six small amber spheres were turned for me by a working jeweller, with what success is shown by the maximum variations from the mean radius given in Table V. Amber was selected for these spheres because its density is slightly greater than that of water. The density was determined by finding that of a saline solution in which the spheres would neither rise nor sink. The observed velocities and those calculated from the empirical formula are given in the last two columns. Although the agreement in some cases is far from good, it is still sufficiently striking when we consider that the formula was derived from observations on air-bubbles ascending in water.

TABLE IV.
Spheres of Paraffin Wax in Aniline.

Temp.	Radius in centim.	Velocity in centim./sec.		
		Observed.	Calculated 12° C.	
			Parabolic formula.	Linear formula.
11·8	·0346	·467	·58	·48
11·2	·0352	·447	·60	·50
10·6	·0404	·598	·77	·67
12·5	·0415	·681	·82	·71
12·6	·0456	·800	·99	·83
12·8	·0531	1·19		1·09
11·3	·0577	1·12		1·22
12·2	·0589	1·19		1·26
13·2	·0589	1·19		1·26
11·0	·0600	1·19		1·30
12·2	·0612	1·23		1·35
10·4	·0623	1·23		1·38
10·0	·0640	1·23		1·43
9·6	·0658	1·36		1·46
12·8	·0727	1·73		1·71
10·4	·0877	2·00		2·18
11·1	·0889	2·06		2·21
10·2	·0923	2·13		2·32
10·2	·158	4·0		4·45

TABLE V.
Amber Spheres in Water.

No.	Mean Radius in cm.	Maximum variation in cm.	Density.	Velocity at 16° in cm./sec.	
				Observed.	Calculated.
I.	·0569	+·0021 -·0024	1·076	2·04	1·94
II.	·0600	± 0007	1·077	2·20	2·08
III.	·0855	+·0029 -·0014	1·077	3·27	3·10
IV.	·1163	+·0017 -·0016	1·077	4·36	4·33
V.	·1391	+·0029 -·0035	1·078	5·24	5·32
VI.	·1732	+·0049 -·0061	1·076	6·55	6·58

7. *Conclusions from these Observations.*

We arrive then at the following conclusions:—

- (1) The terminal velocity acquired by a small bubble ascending through a viscous fluid is the same as that which would be acquired by a solid sphere of the same size and of density differing from that of the fluid by the same amount.
- (2) When the motion is so slow that no eddies are set up in the fluid the velocity of the bubble agrees with that deduced from theoretical considerations by Stokes, on the assumption that no slipping occurs at the boundary.
- (3) When the velocity exceeds a definite critical value, the terminal velocity of bubbles and solid spheres is given by the empirical formula

$$V = k \left(\frac{\rho - \sigma \cdot g}{\rho} \right)^{\frac{2}{3}} \frac{a - h\bar{a}}{v^{\frac{1}{2}}},$$

where the value of the constant k is nearly $\frac{1}{2}$, and of h nearly $\frac{2}{5}$.

[To be continued.]

XXXII. *The Spectra of Hydrogen and the Spectrum of Aqueous Vapour.* By JOHN TROWBRIDGE*.

IT is customary to consider that there are two spectra characteristic of hydrogen—a four-line spectrum, so-called, and another consisting of many lines widely distributed through the spectrum, known as the white spectrum. The four-line spectrum appears when a condenser-discharge is employed with what is called dry hydrogen; it is also readily produced in steam and water-vapour. From the fact that a condenser-discharge seems necessary to excite it in dry hydrogen, it is supposed to indicate a higher temperature than the white spectrum.

The four-line spectrum is found in the atmosphere of the sun; and is a characteristic spectrum of certain types of stars. There are also other lines attributed to hydrogen in the stars which are supposed to indicate conditions of pressure and temperature which perhaps can be imitated and studied in laboratories.

I propose to show in this paper that conclusions in regard to temperature and pressure of hydrogen in celestial bodies, deduced from observations on hydrogen enclosed in glass tubes, are untrustworthy; and that electrical dissociation must

* Communicated by the Author.

be considered as a most important element in determining the characteristics of a gaseous spectrum—more important indeed than the question of pressure and apparent temperature. I shall give my reasons for believing that the four-line spectrum of hydrogen in the atmosphere of the sun is an evidence of aqueous vapour in that atmosphere, and therefore is an evidence of the existence of oxygen in the sun. The conviction is forced upon me that the term dry hydrogen is a misnomer when the gas is subjected in glass vessels to condenser-discharges, or to sufficiently powerful steady currents of electricity.

The bibliography of the subject of the spectra of hydrogen is so extensive that I must, with due regard to the limits of this article, refer the reader to the reports of the Committees of the British Association on the subject of Spectrum Analysis, and to the recognized authorities on this subject; and I do this because I feel that in my experiments I have exceeded the experimental limits of previous investigators, for I have been enabled to employ more powerful electrical discharges than have been hitherto possible. My work therefore does not trench in this respect upon that of previous investigators.

The source of the electrical energy I employed was twenty thousand storage-cells of the Planté type. The direct current from these cells, through a liquid resistance, was used to produce the white spectrum; and a glass condenser consisting of 300 plates of glass, each plate having a coated surface of 16 × 20 inches, with a total capacity of about 1·8 microfarads, was charged by the cells to produce the four-line spectrum.

I had great difficulty at first in obtaining tubes which would stand such powerful discharges. I began my work with end-on tubes, which were closed by plates of quartz luted on with silicate of soda. The electrodes were hollow cylinders of aluminium connected to thick pieces of platinum wire. These wires passed through the walls of the glass tubes and were immersed in large vessels of distilled mercury. After considerable experience, tubes were constructed which would resist the disruptive and heating effect of the discharges. This form of tube, however, was abandoned for another shown in fig. 1. The chief peculiarity of this form of tube was an *x*-ray bulb in place of the end covered with a quartz plate. The reason for the adoption of this form of tube is this:—it was necessary to heat the entire tube to a high temperature for a long period during the process of exhaustion to drive out the air and aqueous vapour before it was filled with hydrogen; and this heating was impossible with a tube having a luted-on end. Moreover, the thin glass of the bulb did not

appreciably absorb the ultra-violet rays until the wave-length 1800 was reached; and this absorption did not affect my conclusions, since my work was confined to the portion of the spectrum studied by astrophysicists. The diameter of the

Fig. 1.

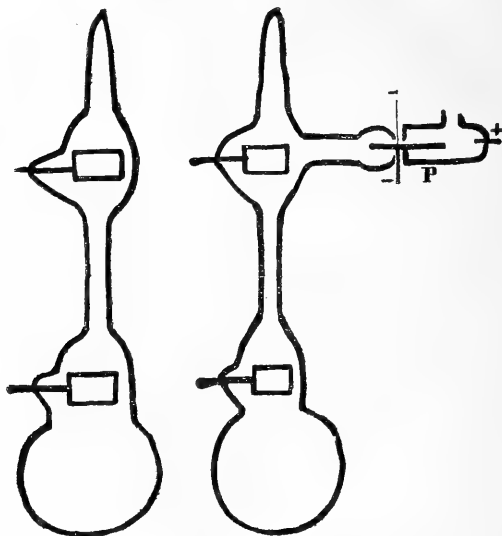

narrowest portion of the tubes was about 1 centim. I employed still another form of tube, shown also in fig. 1. At one side of this tube there was an adjunct consisting of a palladium tube P, joined on the outside of the spectrum-tube to a platinum wire which was inserted in the walls of the tube. A glass vessel filled with dilute sulphuric acid slipped over the palladium tube. At one end of this glass vessel was inserted a platinum wire. The palladium tube was made the cathode, and this platinum wire the anode of a battery. In this way hydrogen is liberated on the surface of the palladium, is occluded, and can be made to pass into the spectrum-tube*.

The tubes which were not provided with palladium tubes were filled with hydrogen or nitrogen through a series of tubes filled with caustic potash—and through a number of tubes filled with phosphoric pentoxide provided with partitions of glass-wool. After many attempts, I adopted the following arrangement of these tubes which proved satisfactory. In the first place, I found it necessary to discard all gums or other adhesive material and to use ground-glass joints and mercury

* A device due to Dr. William Rollins, Boston, U.S.

seals for these joints, having satisfied myself that all other forms of connexions consume time and are worthless. The tubes were mounted on a board, and after the joints had been adjusted, the final adjustment to the gas-holder G, fig. 2. This drying arrangement could be exhausted to a high degree, and would hold the rarefied gas as long as desired. The method of filling the tubes was as follows:—The spectrum-tube was exhausted to about 1 millim., having

Fig. 2.

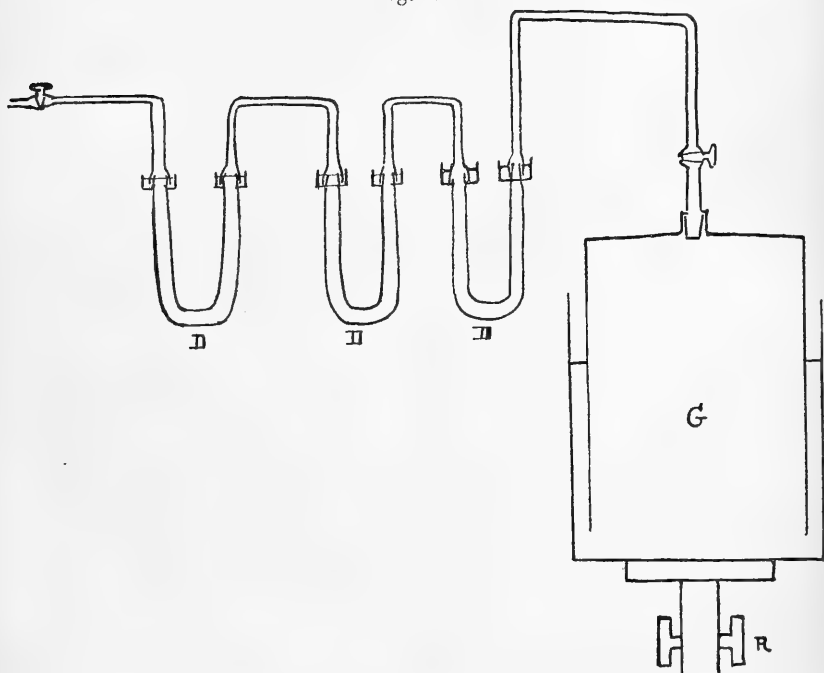

been repeatedly filled with hydrogen. This operation was continued until the hydrogen spectrum appeared. Finally, the tube was exhausted to the *x*-ray stage by long heating and by employing a condenser-discharge. Then the dried gas was admitted until a pressure of about $\cdot 1$ millim. remained in the tube. The vessels with palladium tubes were carefully exhausted to the *x*-ray stage (and beyond, a spark preferring to jump six inches in air to passing through the tube). When these spectrum-tubes, with the palladium adjunct, were con-

nected to the terminals of the battery, a slight heating was sufficient to start a discharge and to cause the occluded hydrogen to appear in the spectrum-tube.

The operation of heating the spectrum-tubes is highly important. Moreover, the discharge from a condenser should be employed in the process of exhaustion, and the operation should be continued for several hours*.

Experience in the preparation of *x*-ray tubes is almost essential to one who essays to investigate the spectra of gases. The vacuum-pump I employed was a modification of Rapp's pump. It was automatic. There was but one valve, and the number of ground-glass joints with mercury seals was reduced to a minimum. The hydrogen was produced by the electrolysis of phosphoric acid and doubly-distilled water. The gas-holder contained many litres of the gas. The nitrogen was prepared by passing air through ammonia water, then through heated copper gauze. The resulting gas was then passed through tubes filled with caustic potash, and finally through tubes of phosphoric pentoxide.

The spectroscope consisted of a Rowland grating with a ruled surface five inches by two inches, and a radius of curvature of sixty inches. The dispersion was small on account of the small number of lines to the inch; but it had the advantage of exhibiting the salient features of the spectra on one plate with a dispersion of the order used by astrophysicists, and thus enabled comparisons to be readily made. The distance between the great H lines in the second spectrum was approximately 2 millim. The camera was on an arm pivoted at half the distance between the grating and the slit. This arrangement was adopted for compactness. The grating and camera were enclosed in a light-tight box; and a lever enabled me to expose the plate when this box was closed.

Various liquid resistances were employed to regulate the strength of the electric current. I finally used distilled water which was kept running through a glass tube. My object was not to measure the currents, but rather to keep them within safe limits. I did not find it necessary therefore to employ cadmium terminals in a solution of iodide of cadmium. The direct battery-current gave me the white type of hydrogen spectrum, while the second type was given by condenser-discharges. A revolving drum provided with suitable metallic strips enabled me to safely charge and discharge the condensers through the spectrum-tubes.

* In this subject of exhaustion of tubes I am much indebted to suggestions of Dr. William Rollins and Mr. Heinze of Boston, who have had long experience in the preparation of *x*-ray tubes.

In working with powerful condenser-discharges, I found that I obtained essentially the same spectrum whether the tube was filled with hydrogen, rarefied air, or nitrogen, notwithstanding the great care taken in heating the tubes and drying the gases. This characteristic spectrum was that of water-vapour, containing lines of hydrogen, of oxygen, and rarefied air. The employment, therefore, of a condenser-discharge in glass tubes apparently drives off aqueous vapour from the glass walls, even if extraordinary care is taken to expel such vapour in the process of exhausting such tubes. My experiments entirely confirm Professor Crookes's statements on this point. Glass seems to be of a permeable nature, and in the process of manufacture is doubtless filled with gases which reveal themselves when disruptive electrical discharges are employed. It does not seem possible that dry hydrogen can exist as such in a glass vessel when it is subjected to a condenser-discharge; and I therefore believe that the spectrum of hydrogen called the four-line spectrum is an evidence of the presence of aqueous vapour, for it can be produced with the greatest ease when we are certain that this vapour is present. This spectrum, to my mind, is an evidence of the presence of oxygen in the sun's atmosphere.

The true spectrum of hydrogen seems to be the white spectrum. This is developed by a steady current which should not exceed a certain strength, for a powerful one drives off also rarefied air from the walls of the tube; and there is a process of occlusion set up if large metallic terminals are employed. Such large terminals are necessary if very strong currents are used. With large aluminium electrodes, under the action of strong currents, spectra of the combinations of nitrogen with oxygen and hydrogen are produced in tubes which have been filled with dry and pure hydrogen. When such tubes have been subjected to powerful currents, it seems impossible to refill them with pure hydrogen. In one case I filled a tube with pure dry nitrogen, and passed a current through it sufficiently powerful to melt down one of the aluminium hollow cylinders which formed an electrode. The aluminium was filled with cavities as if gases had bubbled from the interior. When this tube was filled with dry hydrogen, it gave again spectra of compounds of nitrogen with no trace of the hydrogen spectrum. A powerful condenser discharge, however, produced the aqueous-vapour spectrum. Hydrogen is thus extremely elusive when subjected in glass vessels with metallic electrodes, and in the presence of other gases, to electrical dissociation. Indeed, a steady strong battery-current can be employed at a certain

stage of exhaustion to occlude hydrogen to such a degree that the state of exhaustion in the spectrum-tube is apparently raised, and no discharge can be forced through it until it is subjected to external heat. This occlusion or destructive electrical dissociation is very much in evidence when the terminals of a battery of ten or twenty thousand cells are connected to an *x*-ray tube through a resistance of several megohms. If this tube is properly exhausted, that is by repeated heating and by the use of electrical discharges, no current can be forced through it unless the tube is repeatedly flashed with a powerful Bunsen burner. Suddenly, however, under the action of heat a blue cloud arises in the tube; the cathode beam appears; the anti-cathode grows white-hot, and the exterior resistance must be speedily increased to save the tube. The pressure has apparently been greatly diminished; but the experiment of Dr. William Rollins with two connected *x*-ray tubes, one of which is heated and the other not, the heated one carrying a current while the unheated one resists even an eight-inch spark, shows that this is not the case, and that we have to deal with electrical dissociation and not with a change of pressure. Let us follow this experiment further. Presently the blue cloud in the tube grows smaller; the cathode-beam disappears, and the cloud slowly sinks into the positive electrode. At that moment the *x*-rays flash out with great brilliancy; but in a few seconds the light in the tube is totally extinguished, and a further heating from an external source is necessary before a current can be again forced through the tube and the phenomena can be repeated. It can be repeated, however, as often as desired, although the apparent resistance of the tube is undoubtedly raised by a more or less permanent occlusion of what I believe is water-vapour. This experiment strongly recalls the familiar one of the glowing of platinum under a stream of non-ignited hydrogen. The electrical dissociation of the aqueous vapour evidently produces an intense heat at the anti-cathode, and the *x*-rays are emitted during this dissociation.

If we suppose that there are material bodies circulating about the sun which are charged negatively while the sun is charged positively, we might conceive of a similar action of a difference of potential on rarefied aqueous vapour which might be competent to produce a corona.

The white spectrum of hydrogen produced by the hydrogen coming from palladium is, in its main features, similar to that obtained from electrolytic hydrogen which has been passed through the drying apparatus I adopted. There are, however, some bands which need examination to determine

whether they arise from impurities conveyed into the tube from the pump. They do not appear in nitrogen and in rarefied air; and I am therefore inclined to attribute them to hydrogen. The palladium, apparently, supplies hydrogen more or less continuously to the tube to repair losses from the process of electrical dissociation; and the tube with the palladium adjunct seems more reliable than the form of tube which is filled with hydrogen through drying apparatus which necessarily cannot be subjected to heat, and through which rarefied air is conveyed with the hydrogen into the spectrum-tube.

The study of the effect of powerful electrical discharges on hydrogen led me to endeavour to find the lines discovered by Professor E. C. Pickering in the star ζ Puppis. Since the wave-lengths of these lines satisfy a modification of Bulmer's formula, Professor Pickering attributes them to hydrogen. The wave-lengths of these lines are comprised in the spectral region extending from about 4200 to 3700. I have plotted them as short lines contiguous to the normal solar spectrum in fig. 7. The long lines correspond approximately to the most intense lines or bands in the spectrum of hydrogen produced in the tube provided with the palladium adjunct. The hydrogen spectrum, when regarded as a whole on the scale of small dispersion I have employed, seems to be made up of lines spaced according to a certain order: very much as if two sets of lines spaced according to a certain arrangement should be superposed—the fingers of one hand shifted over those of the other.

The hydrogen lines are more or less intensified bands or dark accumulation of lines almost obscured by the spectra of the compounds of nitrogen and aqueous vapour, if a strong current is employed in a tube provided with aluminium electrodes. It is possible that certain hydrogen bands may be narrowed and rendered lines, in a spectrum of small dispersion such as astrophysicists are compelled to employ, by an electrical dissociation of water-vapour in the presence of an excess of oxygen, and that the new lines in Puppis may be evidence of the presence of this vapour in the star's atmosphere. To test this theory, I filled a tube with oxygen and submitted it to a powerful condenser-discharge. The resulting spectrum was of the general type obtained by these strong discharges in hydrogen, nitrogen, and rarefied air. It is shown in fig. 6. If we compare this spectrum with fig. 3, in which the broad bands only represent hydrogen lines in the gas at atmospheric pressure; with fig. 4, the spectrum in rarefied air; with the lower one in fig. 5, the spectrum obtained in pure nitrogen:

we see that the main hydrogen lines are narrowed and certain hydrogen lines are so faint as to be hardly visible even on the negative.

Fig. 3.

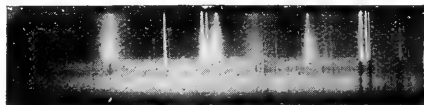

Fig. 4.

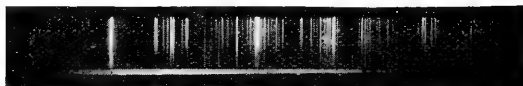

Fig. 5.

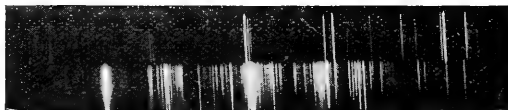
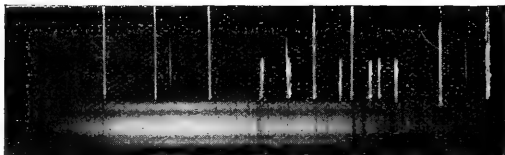

Fig. 6.



Fig. 7.



The general character of the spectral lines of hydrogen in respect to breadth and intensity, seems not to depend so much upon mere pressure and apparent temperature (temperature deduced from calculations of electrical energy in electrical discharges), as upon electrical dissociations of gases: of aqueous vapour, for instance, in the presence of an excess or a small supply of oxygen. I believe, therefore, that any conclusions in regard to temperature and pressure of hydrogen in the stars, deduced from laboratory experiments with electrical discharges in glass vessels, are misleading; since we have to do mainly with phenomena of electrical dissociation, and not alone with those of pressure and apparent temperature—that is temperature which can be measured by calorimetric methods, or which can be calculated from the electrical dimensions of the circuit which is employed.

It would seem, therefore, that the study of electrical disso-

ciation is necessary for the solution of problems relating to the condition of gases in the atmosphere of the sun and in that of the stars. This seems to be a logical necessity since the electromagnetic theory is far-reaching; and sensible heat is only one of the manifestations of electrical energy.

My conclusions are as follows:—

1. When a condenser-discharge is sent through a rarefied gas which is confined in a glass vessel, the gas can no longer be considered in the dry state; for aqueous vapour is liberated from the glass. When a sufficiently powerful condenser-discharge is employed, dry hydrogen, dry nitrogen, and rarefied air give substantially the same characteristic spectrum. When a very powerful steady battery-current is used to excite the tubes filled with these gases, various compounds of nitrogen and oxygen, nitrogen and hydrogen, are formed if aluminium electrodes are employed.

2. The four-line spectrum of hydrogen in the solar atmosphere is an evidence of aqueous vapour, and therefore of oxygen, in the sun.

3. Conclusions in regard to the temperature of the stars, exhibiting hydrogen spectra, are misleading if based upon conditions of pressure and temperature in glass vessels; for conditions of electrical dissociation, of aqueous vapour, for instance, in the presence of an excess or lack of supply of oxygen, are the controlling ones rather than conditions of the mere pressure of the gas.

4. *x*-ray phenomena, produced by a steady battery-current, strongly suggest an electrical theory of the origin of the sun's corona.

Jefferson Physical Laboratory,
Harvard University,
Cambridge, U.S.

XXXIII. *An Application of the Method of Striæ to the Illumination of Objects under the Microscope.* By Prof. R. W. WOOD*.

[Plate III.]

HAVING recently made considerable use of Toepler's "Schlieren-Methode," it occurred to me to see to what extent this most sensitive means of rendering visible minute differences in refractive index could be applied to the illumination of objects under the microscope. The deflexion of a long ray of light by the striæ in the object to be observed, being the fundamental principle of the method, it seemed at

* Communicated by the Physical Society: read June 8th, 1900.

first sight quite hopeless to get results in the short space between the microscope-objective and the object, and I was much surprised to find how well the method worked, even under these unfavorable conditions. On looking over the 'Beiblätter' of the *Annalen* I found, after finishing my observations, that a similar attempt had been made by W. Seibert, and described in the *Zeitschrift für Instrumentenkunde*, ii. p. 92 (1892). With what success the work was attended I do not know, since, at the present moment, I am unable to get access to the early numbers of this journal.

With this preliminary statement I feel warranted in presenting to the Society the results of my observations, as I feel sure that in certain cases the method can be used to advantage in the examination of microscopical objects, in which the detail is lost owing to an almost uniform optical density.

I chose as an object some powdered glass, immersed in cedar oil of the same mean refractive index. The glass particles were almost invisible under ordinary conditions of illumination, as by the use of the substage condenser and diaphragm it was just possible to see the outline of some of the larger particles, but nothing whatever could be seen of their actual form.

I then arranged the illuminating system as follows:—A screen bounded by a straight edge is placed in front of an incandescent gas-lamp, so as to cut off half of the mantle and give a source of light bounded by one perfectly straight side. (A gas-flame with a horizontal screen does about as well.) A small lens of very short focus was placed on the stage, or rather below the stage, as close as possible to the object. The lamp was at a distance of six feet, and the light reflected from the mirror was brought to a focus by this lens, passing through the object on its way. An image of the lamp is formed in space by the lens, and by raising the tube of the microscope the image can be seen. A $\frac{2}{3}$ -inch objective was used, the difficulties increasing as we use objectives of shorter focus. A little strip of thin brass, with a carefully-cut straight edge, was fastened to the stand carrying the "bull's-eye" condenser with a bit of wax, and moved into position between the objective and object, so as to cut off the flame-image with the exception of a narrow thread of light along the straight edge. It is important to have the brass screen set accurately in the plane of the flame-image with its edge parallel to the straight edge of the flame. This adjustment must be made with the microscope focussed on the flame-image, the brass strip being raised and lowered until it is also

in focus. It is then advanced over the flame until nearly all the light is cut off. On lowering the microscope-tube until the object is once more in focus, and carefully advancing the brass strip until practically all of the flame-image is cut off, we shall find that suddenly the glass particles appear with most astonishing sharpness, every irregularity, angle, and facet showing as distinctly as if we were dealing with great lumps of glass in air. The two photographs accompanying this paper (Pl. III.) were taken of the same "field" of glass fragments in oil—one with ordinary illumination, the other by the Schlieren-Method. It is important to choose a lens of such focus that its focal plane shall be half a millimetre or so below the objective when the microscope is focussed on the object. The scheme is shown in the diagram.

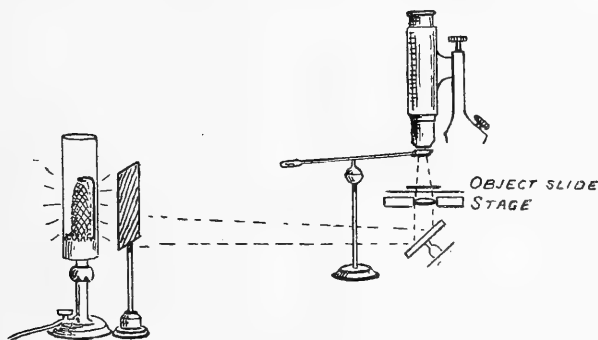

While I doubt if this method will be found to have a very wide application, it appears to me that in certain special cases, perhaps in the examination of rock-sections, it may prove useful. From the nature of things it cannot very well be used with high powers, at least it is not so sensitive under such circumstances.

XXXIV. *The General Motion of Long Waves, with an Examination of the Direct Reflexion of the Solitary Wave.* By R. F. GWYTHER, M.A.*

ALTHOUGH most of the interesting cases of fluid motion are of the steadily progressive type, there are many cases worthy of consideration in which the conditions of progressive motion are not satisfied; and it is here proposed to deal with the case of long waves to a first approximation in the most general manner.

* Communicated by the Author.

For this purpose I shall extend to this case the general principles of the method whereby in a late paper* I attempted to deal with the steady motion of long waves, by finding the differential equation which the velocity-potential must approximately satisfy.

§ 1. Taking

$$\phi + i\psi = F(x + iy, t) \dots \dots \dots (1)$$

to represent a state of motion in fluid otherwise at rest, the condition expressing that the pressure is constant along the free surface may be written

$$2gh = 2gy + u^2 + v^2 - 2\dot{\phi}, \dots \dots \dots (2)$$

where h is an absolute constant.

Expanding this, and replacing differential coefficients of ϕ by their values from (1), and being guided in approximating by the hypothesis that we are dealing with a *long wave*, we obtain

$$2gh = 2gy + F'^2 - (F'F''' - F''^2)y^2 + \&c. \\ - 2\ddot{F} + \ddot{F}''y^2 - \&c. \dots \dots \dots (3)$$

This may be looked upon as the equation to the free surface; but in order that this may continually be the case, we shall have a condition, obtained by operating with

$$\frac{\partial}{\partial t} - \frac{\partial \phi}{\partial x} \frac{\partial}{\partial x} - \frac{\partial \phi}{\partial y} \frac{\partial}{\partial y}.$$

This condition is

$$0 = 2\{g + (\ddot{F}'' - F'F'''' + F''^2)y\} \left\{ F''y - F^{iv} \frac{y^3}{3!} \right\} \\ - \{2F'F'' - 2\ddot{F}' + \ddot{F}''y^2\} \left\{ F' - F'''' \frac{y^2}{2} \right\} \\ + 2F'\ddot{F}' - 2\ddot{F}\ddot{F} + \ddot{F}''y^2 + \&c. \dots \dots \dots (4)$$

Substituting in this from (3) for y , and retaining only the most important of the terms under our hypothesis, we finally obtain

$$2(ghF'' - \ddot{F}) + 2(\dot{F}F'' + 2F'\ddot{F}') - 3F'^2F'' \\ + \ddot{F}''h^2 - F^{iv} \frac{gh^3}{3} = 0. \dots \dots (5)$$

This is the general equation which I proposed to find, being that which, to a first approximation, the function F must satisfy in any *long-wave* motion.

* Phil. Mag. Aug. 1900.

It must be admitted that it does not appear possible to proceed further with the general discussion of this equation; and that might be expected from the very extensive range of motions to which the equation applies. It will still be possible to learn something from the equation in special questions.

§ 2. But first it seems desirable to test the correctness by considering the simpler case of progressive motion.

For this purpose write $F(x, t)$ in the form $F(ct + x)$, so that $\dot{F} = cF'$.

The equation (5) then reduces to

$$\left(c^2 - \frac{gh}{3}\right)h^2F^{iv} = 3F'^2F'' - 6cF'F'' + 2(c^2 - gh)F'', \quad (6)$$

which agrees with that, viz.

$$\left(c^2 - \frac{gh}{3}\right)h^2f'''' = f'^3 - 3cf'^2 + 2(c^2 - gh)f',$$

obtained in the paper referred to above, when it is remembered that we have now performed a differentiation in excess.

It is easily seen that, if we neglect the term $3F'^2F''$, as we may generally do, one form of solution is

$$F(ct + x) = a \tanh m(ct + x), \quad (7)$$

where

$$ma = \frac{c^2 - gh}{c},$$

$$m^2h^2 = \frac{c^2 - gh}{2\left(c^2 - \frac{gh}{3}\right)},$$

a form which suits the circumstances of a low Solitary Wave.

§ 3. I shall now select a special question on which to employ the general equation (5).

In his experiments on the Solitary Wave, Scott Russell found that, with moderate elevations, it was directly reflected from a vertical wall so as to travel without appreciable change of profile or of rate of progression, and, in his experimental investigations to secure exact measurements, the wave was always so reflected at the ends of the trough along which it ran.

For the purpose of investigating the mathematical conditions of such a reflexion, the ordinary treatment of progressive motion will not suffice.

To represent the circumstances, let us replace in (5) $F(x, t)$ by

$$F_1(ct + x) + F_2(ct - x), \quad (8)$$

representing two Solitary Waves of similar circumstances except for their different directions of propagation, and meeting at the plane $x=0$ at the time $t=0$. This will serve in place of a single wave reflected at the wall $x=0$.

Still neglecting the small term, F_1 and F_2 are each separately solutions of (5); and therefore the terms which remain in (5) unsatisfied become

$$2c\{F_1''F_2' - F_2''F_1'\}.$$

Replacing F_1 and F_2 by the function $a \tanh$, this becomes

$$4a^2m^3c \operatorname{sech}^3 m(ct+x)\operatorname{sech}^3 m(ct-x) \sinh 2mct, \quad (9)$$

From this expression, or from general considerations, we see that if $ct+x$ and $ct-x$ are widely different from zero, the term will be very small. Also when x and ct are small, its value may be estimated as

$$4a^2m^3c \sinh 2mct,$$

which, as both m and ct are small, is of the order of the terms we are neglecting. The expression reaches its maximum, about $2\cdot3m^3a^2c$, at the wall, at the time given by $\cosh 2mct = \frac{3}{2}$ before or after the crest of the wave reaches the wall, being both temporary and local.

The condition that (3) may approximately give the form of the free surface is therefore closely satisfied, and the mathematical theory agrees with the experimental investigation that the direct reflexion of a Solitary Wave will have an inconsiderable effect upon its contour and progress.

XXXV. *Proceedings of Learned Societies.*

GEOLOGICAL SOCIETY.

[Continued from p. 268.]

April 25th, 1900.—J. J. Teall, Esq., M.A., F.R.S., President, in the Chair.

THE following communications were read:—

1. 'On a complete Skeleton of an Anomodont Reptile from the Bunter Sandstone of Reichen, near Basel, giving new Evidence of the Relation of the Anomodontia to the Monotremata.' By Prof. H. G. Seeley, F.R.S., F.L.S., V.P.G.S.

2. 'On Longmyndian Inliers at Old Radnor and Huntley (Gloucestershire).' By Charles Callaway, M.A., D.Sc., F.G.S.

The grits, with some associated slaty bands, forming a ridge near Old Radnor were considered by Sir Roderick Murchison to be May Hill Sandstone. The author has discovered that one of the beds of Woolhope Limestone, dipping westward, is crowded with rounded and angular fragments of grit bearing a general resemblance to the

arenaceous parts of the Old Radnor Group. The bedding of the grits is much obscured by crushing, and the rock is sometimes brecciated. Descriptions of microscopic sections of the rock are given in the paper and the specimens are grits, the materials of which are mainly derived from gneissic and igneous rocks. The unconformity of the grits to the Woolhope Limestone Series, and the dissimilarity of the grits to the May Hill Sandstones of Presteign are the chief facts relied upon by the author to establish the pre-Cambrian age of the Old Radnor Series; while the occurrence of the rocks on the strike of the Longmynd, their position with regard to the prolongation of the Church Stretton Fault, and their relations to the Ordovician and Silurian rocks of the area, are in favour of a comparison with the Longmyndian rocks. The lithological resemblances between the Old Radnor Series and the typical Longmyndian are very well marked. Neither the rocks of the Old Radnor Series nor those of the Woolhope Series are affected by any metamorphic change.

The grits and shaly beds of Huntley are unlike the May Hill Sandstones of that district, and as they occur along the axis of the anticline, and lithologically resemble the rocks of the Longmynd, it is highly probable that they also are of Longmyndian age.

May 9th.—J. J. H. Teall, Esq., M.A., F.R.S., President,
in the Chair.

The following communications were read:—

1. 'The Pliocene Deposits of the East of England. Pt. II.:—The Crag of Essex (Waltonian), and its Relation to that of Suffolk and Norfolk.' By F. W. Harmer, Esq., F.G.S. With a Report on the Inorganic Constituents of the Crag by Joseph Lomas, Esq., F.G.S.

The term 'Red Crag,' including, as it does, beds differing considerably in age, is vague, and, when we attempt to correlate the East Anglian deposits with those of other countries, inconvenient; the Scaldisian zone of Belgium, for example, with its southern fauna, representing one part of it, and the Amstelian of Holland, in which Arctic shells are common, another. While retaining the name for general use, therefore, the following more definite classification of its various horizons, and of those of the English Pliocene generally, is proposed (see p. 354).

The line separating the Older and Newer Pliocene is now drawn by the author between the Lenham Beds, containing *Arca diluvii* and other characteristic Miocene species of the North Sea (or of the Italian Pliocene), and the Coralline Crag, the latter being considered as the oldest member of a more or less continuous and closely connected series of Newer Pliocene age. The palæontological difference between the Coralline and Walton Crags is shown to be less than has hitherto been supposed.

The upper Crag-deposits arrange themselves in horizontal and not in vertical sequence, assuming always a more boreal and more recent character as they are traced from south to north. They are

NEWER PLIOCENE.		
CROMERIAN.	So-called Forest-bed Series. (Freshwater & Estuarine.) Zone of <i>Elephas meridionalis</i> .	
WEYBOURNIAN.	Weybourn and Belough Crag. Zone of <i>Tellina balthica</i> . (Marine.)	
CHILLESFORDIAN.	Chillesford Clay and Sand. Zone of <i>Leda oblongoides</i> . (Estuarine.)	
ICENIAN.	Norwich Crag. (Marine.) Northern part: Zone of <i>Astarte borealis</i> . Southern part: Zone of <i>Maetra subtruncata</i> .	
BUTLEYAN.	Red Crag of Butley and Bawdsey. Zone of <i>Cardium grœnlandicum</i> .	AMSTELIAN. Upper part.
NEWBOURNIAN.	Red Crag of Sutton, Newbourn, Waldringfield, etc. Zone of <i>Maetra constricta</i> .	Lower part.
?	Red Crag of Bentley & Tattingstone.	
WALTONIAN.	Crag of Essex. Oakley horizon: Zone of <i>Maetra obtruncata</i> . Walton horizon: Zone of <i>Neptunœa contraria</i> .	POEDERLIAN. SCALDISIAN. Zone à <i>Trophon antiquum</i> (<i>Chryso- domus contraria</i>).
GEDGRAVIAN.	Coralline Crag. Zone of <i>Pecten Gerardii</i> .	CASTERLIAN. Zone à <i>Isocardia cor.</i>
OLDER PLIOCENE.		
LENHAMIAN.	Lenham Beds. Zone of <i>Arca diluvii</i> . Boxstone fauna.	DIESTIAN. Ferruginous sand- stones of Diest. Waenrode Beds.

the littoral accumulations of a sea retreating, not continuously, but at intervals, in a northerly direction.

A new horizon of the Crag, represented by some beds at Little Oakley, between Walton and Harwich, is described, indicating the period, before the southern mollusca had commenced to disappear, when a few boreal species were beginning to establish themselves in greater or less abundance in the Anglo-Belgian basin. Though hitherto unnoticed, the fauna of this locality has proved to be exceedingly rich, more than 350 species and varieties having been

there obtained, from a seam 10 yards long and less than 2 feet in average thickness.

The three divisions of the Red Crag now proposed (the exact position of the Bentley bed not having been ascertained at present), namely, Waltonian, Newbournian, and Butleyan, are distinguished alike by the difference of their faunas, and by the position which they occupy. The first, with its southern shells, is confined to the county of Essex; the second, containing a smaller proportion of southern and extinct, and a larger proportion of northern and recent species, occupies the district between the Orwell and Deben, and a narrow belt of land to the east of the latter river; the third, in which Arctic forms such as *Cardium groenlandicum* are common, is found only farther north and east. All these beds are believed to have originated in shallow and land-locked bays, successively occupied by the Red Crag sea as it retreated northward, which were silted up, one after the other, with shelly sand.

The Norwich Crag (Icenian) occupies an area entirely distinct from that of the Red Crag, no instance being known where the one overlies the other in vertical section; the fauna of the former is, moreover, more boreal and comparatively poor in species. The Arctic species, *Astarte borealis*, is confined to the northern part of the Icenian area; its introduction seems to mark a stage in the continued northerly retreat of the sea. The Icenian deposits thicken rapidly northward and eastward, and are believed by the author to constitute part of the great delta-formation of the Rhine.

The mammalian remains found at the base of the different horizons of the Crag in a remanié bed, containing material derived from various sources, are considered to be also derivative from deposits, older than the Coralline Crag, formerly existing to the south.

The Chillesfordian (estuarine), and Weybournian (marine) deposits, the latter characterized by the sudden appearance in the Crag basin, in prodigious abundance, of *Tellina balthica*, represent separate stages in the continued refrigeration of East Anglia during the Pliocene period; but the so-called 'Forest-bed' or Cromerian (fresh-water and estuarine) with its southern mammalia, and its flora, similar to that of Norfolk at the present day, clearly indicates a return to more temperate conditions, and should therefore be separated alike from the Weybourn Crag on the one hand, and from the *Leda-myialis* Sands and the Arctic freshwater-bed of Mr. Clement Reid on the other. The two latter seem naturally to group themselves together, and with the Glacial deposits.

The conditions under which the Red-Crag beds originated seem to exist at the present day in Holland, where sandy material brought down by rivers, with dead shells in great abundance from the adjacent sea, is being thrown against and upon the coast, principally by means of the westerly winds now prevalent. From meteorological considerations, it seems probable that strong gales from the east may have prevailed over the Crag area during the latter part of the Pliocene epoch. No other explanation of the accumu-

lation of such vast quantities of dead shells on the East Anglian margin of the North Sea at that period can be suggested. At the present day, the eastern shores of Norfolk and Suffolk are almost destitute of such débris.

Mr. J. Lomas, in his Report on the Inorganic Constituents of the Crag, states that lithologically the various subdivisions of the Red Crag are the same. Differences of colour may be traced to definite lines of flow along which water containing ferruginous matter has moved.

Among the rarer minerals separated out by high-density fluids, zircon, rutile, cyanite, ilmenite with leucoxene, garnets, andalusite, corundum, tourmaline, muscovite, biotite, glauconite, orthoclase, labradorite, albite, and microcline are found. In the heavy fractions red garnets are very common. Tourmaline occurs abundantly, and includes green, blue, yellow, and brown varieties. Muscovite predominates over biotite, and often includes rounded crystals of zircon, rutile, etc. Ferro-magnesian minerals, with the exception of biotite, are absent. Glauconite is very plentiful, and frequently retains the form of the organisms of which it has formed casts.

In the Norwich Crag the same minerals are present, but muscovite is found in excess. The Chillesford Sands differ from the Crag only in the absence of glauconite. The bulk of the material of the beds described consists of well-rounded grains of quartz, seldom showing traces of secondary crystallization. Flint occurs as large pebbles, and fine angular chips are met with in the sands.

2. 'A Description of the Salt-Lake of Larnaca in the Island of Cyprus.' By C. V. Bellamy, Esq., F.G.S., Assoc.M.Inst.C.E.

After a brief description of the general geology and geography of the island, the author proceeds to deal with the topography of the Lake, which occurs in a basin shut off from the sea, its deepest part being about 10 feet below sea-level. The barrier between the salt-lake and the sea is made of stiff calcareous clay associated with masses of conglomerate resting on plastic clay, that on watery mud, and that again on stiff calcareous clay. The sea-water appears to percolate through the highest deposits, meeting with checks in the conglomerates, and thus reaches the basin somewhat slowly, where it is evaporated to dryness by the summer heat and deposits its salt. Artificial channels have been made, to carry the flood-water from the land direct to the sea, so that it does not dilute the brine of the lake. The rainfall in the catchment-area round the lake is at the most only enough to supply 223 million gallons, and as the lake contains 480 million gallons when full, the balance of 257 million gallons must be derived from the sea. The lake is probably situated on what was an extensive arm of the sea at the close of the Kainozoic era. The salt-harvest begins in August, at the zenith of summer heat, and it is reported that a single heavy shower at that time of year suffices to ruin it. Observations are given on the density of the water, the plants and animals in the water, and the lake-shore deposits.

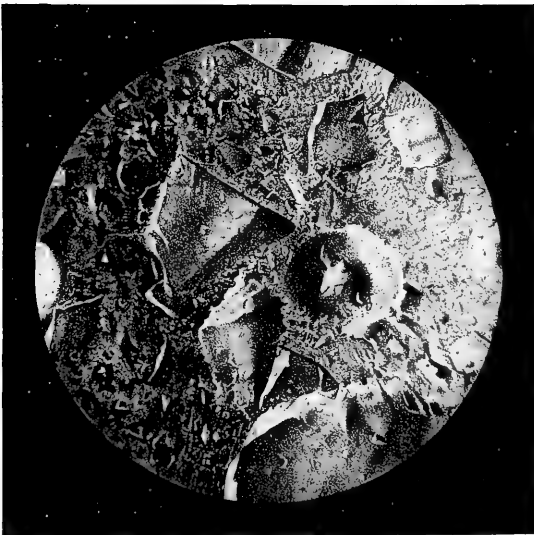

THE
LONDON, EDINBURGH, AND DUBLIN
PHILOSOPHICAL MAGAZINE
AND
JOURNAL OF SCIENCE.

[FIFTH SERIES.]

OCTOBER 1900.

XXXVI. *Reflexion and Transmission by Condensers of Electric Waves along Wires.* By EDWIN H. BARTON, D.Sc., F.R.S.E., A.M.I.E.E., Senior Lecturer in Physics at University College, Nottingham, and LOUIS LOWNDS, B.Sc., 1851 Exhibition Science Research Scholar*.

CONTENTS.

	SUBJECT.	Page
INTRODUCTION		357
EXPERIMENTAL ARRANGEMENTS		359
THEORY.		
Preliminary		360
Intermediate Condenser		361
Reflexion at Electrometer negligible		366
Intermediate Resistance		367
Terminal Condenser		367
Electrometer-Throw for Single Passage of Wave-Train		369
Transmitted System		369
Stationary Waves at Electrometer		371
Discussion of Interference Phenomena		374
Reflected System		376
Detection of Phase-change of Reflected Waves		377
EXPERIMENTS		378
COMPARISON OF THEORY AND EXPERIMENT		388

INTRODUCTION.

1. **I**N 1892 J. Ritter von Geitler † experimentally detected the reflexion by a condenser of electric waves along wires. He also examined qualitatively the effects of con-

* Communicated by the Physical Society: read January 26, 1900.

† "Inaugural Dissertation," Bonn, January 1893. *Wied. Ann.* xlix. pp. 184-195 (1893).

densers of various sizes; but no attempt was made to give a complete theory of the various phenomena involved, and by careful quantitative observations compare experiment with theory. This fuller examination one of us, who followed von Geitler under the late Professor Hertz, at Bonn, determined to attempt when opportunity offered. The present paper embodies the result of the work carried out during the session 1898-99 at University College, Nottingham, and advances the problem another stage towards complete solution.

2. The phenomena are more complicated than might be at first supposed. This is chiefly owing to the fact that the wave-train, reflected by the condenser under examination, passes and repasses between the point of reflexion and the oscillator at the beginning of the line. Hence the effect to be observed, owing to reflexion at any condenser, is a function not only of the coefficient of that reflexion but also of the other constants of the circuit. To avoid unnecessary complication, the wave-train transmitted by the condenser is always completely absorbed by a suitable bridge at the end of the line.

3. By placing the electrometer beyond the condenser, the wave-train transmitted is determined, and by placing the condenser *far* beyond the electrometer the wave-train reflected is measured. In order to determine the phase-lag introduced in the reflected wave-train, the condenser is placed in a number of positions, each of which is only a short distance beyond the electrometer. We thus obtain stationary waves by the interference of the incident and reflected wave-trains, and these, explored by the electrometer, exhibit the phase-change sought. To bring this change of phase into clearer relief, stationary waves are also obtained by a resistance-bridge, whose reflexion coefficient is the same as that of the condenser, but whose phase-change is π simply.

4. The results obtained with the three condensers used are all in fair accord with theory, both as to phase-lag and coefficient of reflexion and transmission. The experimental discrepancy, if such it can be called, is in the direction of less reflected and less transmitted than the long-wave theory predicts.

It may be mentioned here that the experiments, though given in this paper after the theory, were in practice finished before the theory was fully worked out. The experimental results are thus free from any bias due to anticipation based on theory. Each set of readings was accepted simply on the

ground of consistency of the separate readings. Further, the experimental curves were in all cases plotted before superposition of the theoretical ones.

EXPERIMENTAL ARRANGEMENTS.

5. The arrangement of the apparatus adopted for observing the reflected wave-trains is diagrammatically represented in fig. 1. In this figure, A denotes the battery of two storage-

Fig. 1.—Circuit arranged for Reflected System and for Interference Phenomena.

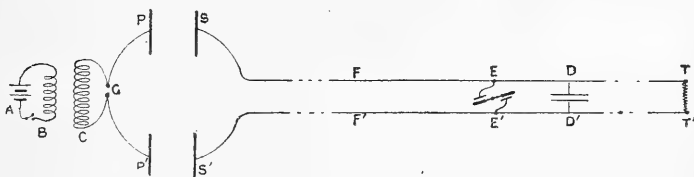

cells, B and C are the primary and secondary coils respectively of the induction-coil, of which C has a resistance of 3000 ohms and an inductance of about 20 henries. G is the spark-gap, which was adjusted to 2 mm., the balls being of brass, highly polished before each occasion of experimenting. The wire PGP', measured along the semicircle, is about 2 metres long. PP' are the edge-views of the condenser-plates of zinc 40 cm. diameter placed opposite to and 30 cm. distant from the precisely similar disks SS'.

6. The line is represented by SEDTT'D'E'S', and consists of two parallel copper wires, 1.5 mm. diam., and kept 8 cm. apart by wood separators at intervals of about 1 metre. These wood separators are about 12 cm. long, 2.5 cm. wide, and 1.2 cm. thick, and were well saturated before use in melting paraffin-wax. Their resistance was thus raised to something over 60,000 megohms each, which thus renders the leakage of the line quite negligible.

7. EE' denotes the electrometer, which has a single plane needle initially uncharged, and suspended by a fine quartz fibre between two disks attached to the line at E and E'. The needle is therefore electrified by induction whenever a wave-train passes EE', and its ends are consequently attracted to the disks whatever the sign of their potential-difference. The first throw of the electrometer is thus proportional to the time-integral of the square of the potential-difference. The needle is provided with weak magnetic control and a plane mirror by Adam Hilger, its indications being read by

a distant telescope and scale. The induction-coil is put on end to avoid any magnetic effect on the electrometer-needle. The leads also of the coil are kept close together, and, before taking a set of readings, the electrometer is tested as to the adequacy of these precautions against possible disturbance. The disks and the ends of the needle are each about 2 cm. diam. and 1 cm. apart. It will be shown later that the reflexion of waves at the electrometer, regarded as a condenser on the line, is extremely small and quite negligible.

8. TT' denotes the terminal bridge which is used to absorb the waves on arrival at the end of the line. It consists of graphite markings on a disk of ground glass, 3 inches diameter, and before each set of readings is adjusted to the resistance which corresponds to complete absorption; namely, for the line in question, 560 ohms*.

DD' denotes one of the condensers in use to reflect the waves. For the transmitted system they are removed from DD' and inserted at FF'. They were all three made of disks of zinc 1 cm. apart, their radii being respectively 15, 9, and 5 cm. The two disks were kept at the right distance apart, and insulated by pieces of wood saturated in paraffin-wax, notched and secured with shellac.

9. The total length of the line from S to T is of the order 166 metres. The distance SE is 116 metres, SF is of the order 60 metres. ED varies from about .75 metre to 50 metres. Exact details will be given in connexion with the various experiments.

10. The waves generated by the primary oscillator are of the damped simple harmonic type 8.5 metres long, their logarithmic decrement per wave being 0.6. Thus the wave-train launched upon and propagated along the line with the speed of light is a damped train with its large end or head leading, the tail, after about 10 or 12 waves, being almost negligible. As the waves proceed along the line they suffer attenuation, also some loss on reflexion at the oscillator. The constants expressing these effects were previously determined experimentally on the line now in use, and their numerical values will be introduced into the theory later.

THEORY.

11. *Preliminary.*—The plan adopted throughout the experiments is to take (1) readings of the electrometer with no condenser on the line, but only the absorbing-bridge at the

* "Absorption of Electric Waves, &c.," Phil. Mag., January 1897.

end; alternated with (2) electrometer-readings with a condenser on the line at an intermediate position, as well as the absorbing-bridge at the end. The mean ratio of the readings under the different conditions constitutes the experimental estimate of the effect produced by the condenser in question when in that position.

12. In order, however, to interpret the experimental results and compare them with theory, we need to trace the history of the wave-train reflected by the condenser until it is, practically, extinguished by its losses through repeated reflexion and attenuation. The effect at the electrometer when no condenser is on the line may be represented by a single time-integral which, without sensible error, owing to the damping of the wave-train, may be taken from the commencement of the time to infinity. The effect at the electrometer when a condenser is on the line requires, however, an infinite series of integrals.

13. To construct this series we must first determine the various elements of which it consists. We must accordingly treat the case of a condenser on the line, *not* at the end. This will be referred to as an *intermediate* condenser. We have here to determine the coefficients of reflexion and transmission and the phase-lags of both the reflected and transmitted portions. The case of a *terminal* condenser must also be treated, since the oscillator at the beginning of the line falls under this category. Here, only two constants are required, the amplitude and phase of the reflected portion. These points will now be dealt with in order, together with subsidiary matters that crop up by the way and are included for the sake of completeness.

14. We shall treat the circuit throughout as what Mr. Oliver Heaviside terms a "distortionless circuit," not that it is strictly distortionless, but because it is very nearly so; and this treatment, while sacrificing nothing of material accuracy, considerably simplifies the analysis. Prof. W. B. Morton* has shown that for the circuit in question the errors thus involved are less than one in a thousand.

15. *Intermediate Condenser.*—At the place of attachment of the condenser let ϕ_1 denote the potential-difference of the two wires of the line due to the arrival there of the incident wave-train. Then ϕ_1 is a function of the time. Similarly let ϕ' and ϕ_2 correspond to the reflected and transmitted wave-trains respectively. Then by consideration of potential and Heaviside's theory of the distortionless circuit, assumed

* Phil. Mag., March 1899.

valid to the head of the wave-trains, we have

$$\left. \begin{aligned} \phi_1 + \phi' &= \phi_2 = Q/S', \\ i_1 &= \phi_1/Lv, \quad i' = -\phi'/Lv, \quad i_2 = \phi_2/Lv, \\ i_1 + i' - i_2 &= \frac{dQ}{dt}, \\ Q &= \phi_2 = 0 \text{ for } t = 0; \end{aligned} \right\} \dots (1)$$

where Q is the quantity of electricity at time *t* on the positively charged plate of the condenser of capacity *S'* (in electromagnetic units), and the *i*'s denote the currents in the positive wires due to the wave-trains denoted by the ϕ 's bearing the same subscript or dash; L denotes the inductance of the line per unit-length, and *v* is the speed of free æther radiation. These equations were used by Heaviside with reference primarily to waves of telephonic frequency, but are here adopted as a working approximation for the phenomena which obtain in the case of Hertzian waves.

On eliminating the *i*'s and Q, we have

$$\left(LvS' \frac{\partial}{\partial t} + 2 \right) \phi' = -LvS' \frac{\partial}{\partial t} \phi_1, \dots (2)$$

and

$$\left(LvS' \frac{\partial}{\partial t} + 2 \right) \phi_2 = 2\phi_1. \dots (3)$$

These expressions might have been written at once from Heaviside's operational results, the reflexion and transmission coefficients for an intermediate bridge being respectively

$$\frac{-Lv}{2Z + Lv} \quad \text{and} \quad \frac{2Z}{2Z + Lv}, \dots (4)$$

where the resistance operator Z is here equivalent to

$$\left(S' \frac{\partial}{\partial t} \right)^{-1}$$

since the bridge is a condenser merely.

16. Now if the incident wave-train is a damped sine function right up to its head, we may write without loss of generality,

$$\phi_1 = e^{-kpt} \cos (pt + \iota). \dots (5)$$

Substituting this value of ϕ_1 in equations (2) and (3), and satisfying the initial conditions expressed in (1), we obtain in the usual way the following solutions :—

$$\phi' = Ae^{-kpt} \cos (pt + \iota + \alpha) - B \cos (\iota + \beta) e^{-2pt/x'}, \dots (6)$$

$$\phi_2 = Ee^{-kpt} \cos (pt + \iota + \beta) - B \cos (\iota + \beta) e^{-2pt/x'}; \dots (7)$$

where

$$\left. \begin{aligned} A \cos \alpha &= \frac{-\chi'^2 + 2k\chi' - k^2\chi'^2}{\Delta'} = a, \\ A \sin \alpha &= -2\chi'/\Delta' = a', \\ B \cos \beta &= \frac{4 - 2k\chi'}{\Delta'} = b = 1 + a, \\ B \sin \beta &= -2\chi'/\Delta' = b' = a', \\ \Delta' &= 4 + \chi'^2 - 4k\chi' + k^2\chi'^2, \\ \chi' &= LvS'p. \end{aligned} \right\} \dots (8)$$

and

We have then finally

$$\left. \begin{aligned} A &= + \sqrt{a^2 + a'^2}, \quad \tan \alpha = a'/a, \\ B &= + \sqrt{b^2 + b'^2} \text{ and } \tan \beta = b'/b. \end{aligned} \right\} \dots (9)$$

The algebraic signs of a , a' , b , and b' being preserved show in which quadrants α and β should be taken.

17. We see from (6) and (7) that the reflected and transmitted wave-trains consist each of a damped periodic part and a purely exponential part. The exponential part we shall have to omit from the first portion of the subsequent analysis, because we have no experimental proof of the exact shape of the head of the incident wave-train. For the same reason we shall at first omit the ι also. The greatest correction which this approximate theory can in any possible case require will be subsequently discussed and evaluated. (See arts. 60 and 61.)

18. Under these simplifications we may compactly represent the three wave-trains as follows:—

$$\left. \begin{aligned} \text{Incident wave-train, real part of } e^{(i-k)pt}, \\ \text{Reflected wave-train, real part of } (a + a')e^{(i-k)pt}, \\ \text{Transmitted wave-train, real part of } (b + b')e^{(i-k)pt}; \end{aligned} \right\} (10)$$

where a , a' , b and b' have the values assigned to them in (8) and have been confirmed by Heaviside's operational methods.

19. It may be noted in passing that if the incident wave-train were not damped, the reflected and transmitted trains would differ in phase by $\frac{\pi}{2}$ exactly. For on putting $k=0$ in the expressions for $\tan \alpha$ and $\tan \beta$ they become $\frac{-2}{-\chi'}$ and $\frac{-\chi'}{2}$ respectively, hence their product is -1 . This

simple relation is seen to be slightly modified by the damping.

Again, if the damping were not present, we should have the simple result $A^2 + B^2 = 1$, as should be the case, showing that the sum of the energies of the reflected and transmitted wave-trains equals the energy of the incident one. To effect the corresponding check for the damped waves, one would need to take the time-integrals from zero to infinity of the square of the amplitude for the incident, reflected, and transmitted wave-trains, the exponential terms being no longer ignored.

As a further check it may be noted that the equation for potential-difference at the condenser is always satisfied. For the equation in question, viz.: $\phi_1 + \phi' = \phi_2$, reduces to $1 + a = b$ and $b' = a'$, and by (8) this is an identity for all values of k and χ' .

20. If the capacity of the condenser be imagined to increase from zero to infinity, while the circuit and the incident wave-train are maintained the same, we see by equations (6) and (8) that the reflexion-coefficient A grows from zero to unity, while the phase-difference α , but for the slight modification due to damping, changes from $\frac{-\pi}{2}$ to $-\pi$.

Similarly, a reference to equations (7) and (8) shows that as the capacity of the condenser changes from zero to infinity the transmission-coefficient B changes from unity to zero, while the phase-difference, but for the damping, changes from zero to $\frac{-\pi}{2}$.

21. These features for several sizes of condenser are exhibited in Table I., and are graphically represented in figs. 2, 3, and 4, in which the dotted lines represent the values which the coefficients would assume if there were no damping, and the full lines the corresponding values for the damping actually present in the experimental case in question. The incident, reflected, and transmitted amplitudes are shown by OI , OR , and OT respectively. The curves in fig. 5 show at

Fig. 2.—Reflexion and Transmission at Small Condenser.

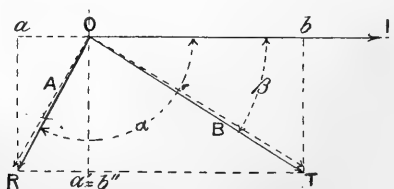

Fig. 3.—Reflexion and Transmission at Medium Condenser.

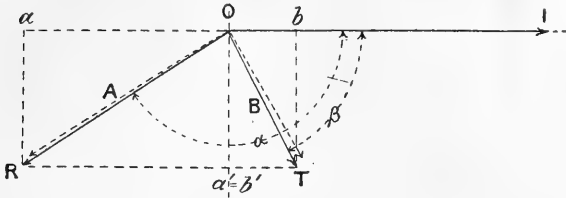

Fig. 4.—Reflexion and Transmission at Large Condenser.

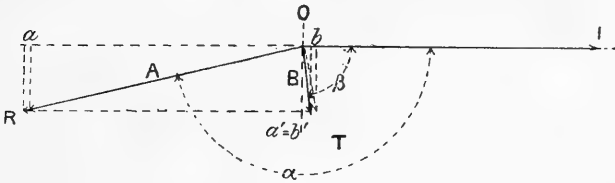
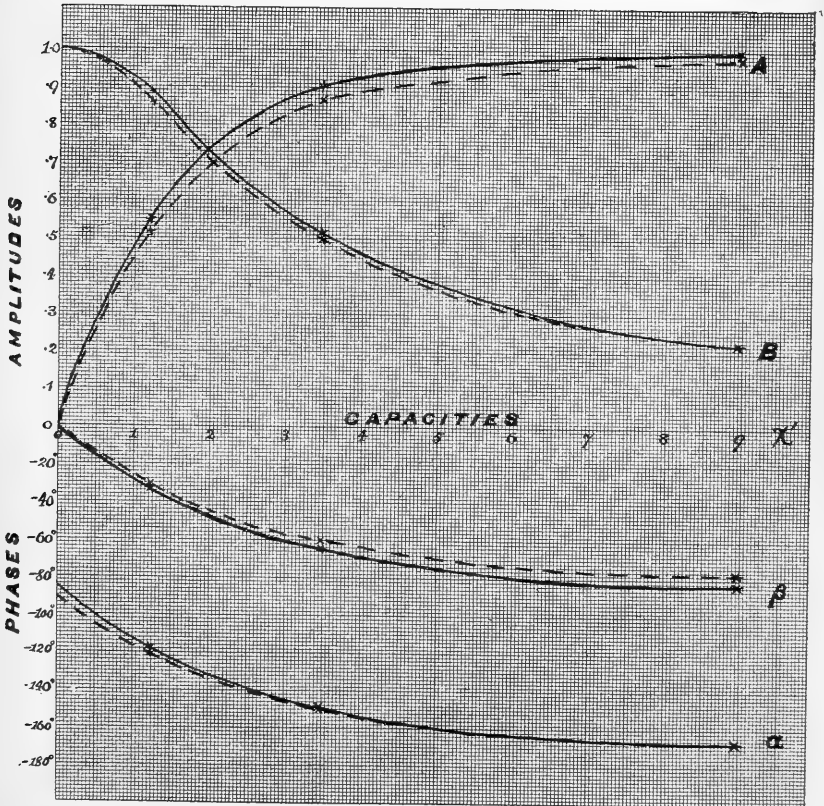

Fig. 5.—Amplitudes and Phase Changes of Reflected and Transmitted Waves with Damping and without.



one glance the continuous changes in A, α , B, and β as the capacity changes without break from zero towards infinity. Here, again, the full lines show the values of the constants for the damping actually in use, and the broken lines the ideal values when damping is absent.

TABLE I.—Reflexion and Transmission Constants of Intermediate Condensers.

Condenser Constant $\chi' = LvS'p$.	Constants of Reflected Wave-Train.				Constants of Transmitted Wave-Train.				Damping Constant of Incident Wave-Train.
	<i>a.</i>	<i>a'</i> .	A.	α .	<i>b.</i>	<i>b'</i> .	B.	β .	
0	0	0	0	$-\frac{\pi}{2}$	+ 1	0	+ 1	0	Zero, <i>i. e.</i> Incident Wave-Train Undamped.
1.21	-.268	-.443	+ .518	$-121^\circ 10'$	+ .732	-.443	+ .856	$-31^\circ 10'$	
3.47	-.751	-.433	+ .867	$-150^\circ 5'$	+ .249	-.433	+ .500	$-60^\circ 5'$	
8.95	-.952	-.214	+ .976	$-167^\circ 25'$	+ .048	-.214	+ .22	$-77^\circ 25'$	
∞	-1	0	+ 1	$-\pi$	0	0	0	$-\frac{\pi}{2}$	
0	0	0	0	$-84^\circ 36'$	+ 1	0	+ 1	0	Incident Wave-Train $ise^{-kpt} \cos pt$ where $k=0.0955$ as in Experimental Case.
1.21	-.249	-.483	+ .543	$-117^\circ 16'$	+ .751	-.483	+ .89	$-32^\circ 46'$	
3.47	-.775	-.468	+ .906	$-148^\circ 52'$	+ .225	-.468	+ .52	$-64^\circ 19'$	
8.95	-.972	-.220	+ .994	$-167^\circ 16'$	+ .028	-.220	+ .22	$-82^\circ 43'$	
∞	-1	0	+ 1	$-\pi$	0	0	0	$-95^\circ 24'$	

22. *Reflexion at Electrometer negligible.*—It is now necessary to inquire whether the electrometer reflects any appreciable part of the wave-train incident upon it. As previously mentioned, this is not the case.

Between the disks attached to the line at EE' (fig. 1) the ends of the needle are interposed, each disk with its adjacent needle-end forming a condenser whose plates are 1 centim. radius and 1 centim. apart. The electrometer as a whole constitutes a set of two such condensers in series. Hence the capacity interposed between E and E' is half that due to one disk and needle-end.

Taking the correction for the edges of the plates in a parallel disk condenser given in Kohlrausch's 'Practical Physics,' we thus obtain S' , the capacity between E and E', equals $\frac{1}{2} \times 10^{-21}$ in electromagnetic c.g.s. units. And for the

present experimental case, $Lv = 56 \times 10^{10}$ and $p = 2 \times 10^8$ in the same units. Hence $\chi' = LvS'p = \cdot 037$, $a = -\cdot 00035$, $a' = -\cdot 019$, and $A^2 = a^2 + a'^2 = \cdot 00036$.

Thus the energy reflected by the electrometer is of the order 0.04 per cent. of that incident upon it, and is therefore quite negligible.

23. *Intermediate Resistance.*—It seems desirable for the purpose of contrast with the reflexion from a condenser to consider now that of an intermediate resistance. In this case the phase-change introduced does not vary with the amplitude coefficient. But, however the resistance is varied, the phase-change introduced in the reflected wave-train remains constant and equal to a lag of π .

24. Thus, using the same notation as before, we have the following equations as the conditions connecting potential-difference and current where a bridge of resistance R' is placed on the line, the line being understood to extend beyond it.

$$\begin{aligned} \phi_1 + \phi' &= \phi_2, \\ i_1 &= \phi_1/Lv, \\ i' &= -\phi'/Lv, \\ i_2 &= \phi_2/Lv, \\ i_1 + i' - i_2 &= \phi_2/R'. \end{aligned}$$

Whence, on elimination of the i 's, we obtain

$$\frac{\phi'}{\phi_1} = \frac{-Lv}{2R' + Lv} \quad \text{and} \quad \frac{\phi_2}{\phi_1} = \frac{2R'}{2R' + Lv}.$$

25. Or, we may say that if the incident wave-train be a cosine function of the time, damped or not, the reflexion-coefficient and phase-change are respectively

$$A' = \frac{+Lv}{2R' + Lv}, \quad \text{and} \quad \alpha' = -\pi. \quad . \quad . \quad (11)$$

Similarly, the amplitude-coefficient and phase-change for the transmitted wave-train are seen to be respectively

$$B' = \frac{+2R'}{2R' + Lv}, \quad \text{and} \quad \beta' = 0. \quad . \quad . \quad (12)$$

26. *Terminal Condenser.*—Let the capacity of the condenser at the end of the line be S_0 , the previous notation for incident and reflected waves &c. being retained. We then

have

$$\left. \begin{aligned} \phi_1 + \phi' &= Q/S_0, \\ i_1 &= \phi_1/Lv, \quad i' = -\phi'/Lv, \\ i_1 + i' &= \frac{\partial Q}{\partial t}, \\ Q &= \phi_1 + \phi' = 0, \quad \text{for } t=0. \end{aligned} \right\} \dots (13)$$

On elimination of Q and the *i*'s these equations yield

$$\left(1 + LvS_0 \frac{\partial}{\partial t}\right) \phi' = \left(1 - LvS_0 \frac{\partial}{\partial t}\right) \phi_1; \dots (14)$$

which is equivalent to Heaviside's expression for reflexion at a terminal condenser.

27. Writing for the incident wave-train

$$\phi_1 = e^{-kpt} \cos (pt + \iota),$$

the solution of (14) may be written

$$\left. \begin{aligned} \phi' &= Ce^{-kpt} \cos (pt + \iota + \gamma) - (\cos \iota + C \cos \iota + \gamma)e^{-pt/\chi_0}; \\ \text{where} \quad C \cos \gamma &= \frac{1 - \chi_0^2 - k^2 \chi_0^2}{\Delta_0} = c, \\ C \sin \gamma &= \frac{-2\chi_0}{\Delta_0} = c', \\ C &= +\sqrt{c^2 + c'^2}, \\ \tan \gamma &= \frac{c'}{c} = \frac{-2\chi_0}{1 - \chi_0^2 - k^2 \chi_0^2}, \\ \chi_0 &= LvS_0 p, \quad \text{and} \quad \Delta_0 = 1 + \chi_0^2 - 2k\chi_0 + k^2 \chi_0^2. \end{aligned} \right\} (15)$$

Or, if we ignore, as before, the exponential term and let the incident wave-train be the real part of $e^{(i-k)pt}$, then the solution is

$$\phi' = (c + c'i)\phi_1, \dots (16)$$

the *c*'s having the values given in equations (15).

In the case of a terminal condenser we see that if $k=0$, $C=1$ for all values of χ_0 . This simple relation is slightly disturbed by the damping when present.

28. This theory of the terminal condenser has been given for the sake of dealing with the reflexion which occurs at the oscillator at the beginning of the line. It may be approximately treated as a condenser simply, because the interval elapsing between the launching of the wave-train along the line and its return after traversing about 300 metres is so

small (say one-millionth of a second), that we may regard the spark-gap of the primary as hot enough to act as a short circuit to the secondary of the induction-coil, whose inductance is of the order 20 henries.

29. *Electrometer-throw for Single Passage of Wave-train.*—It might at first be supposed that the phase at the head of a wave-train would have no effect on the electrometer-throw, except when that wave-train was interfering with another, and so producing stationary waves in the neighbourhood of the electrometer. This, however, is not the case. On the contrary, the throw produced by the passage of a single wave-train of given amplitude, period, and damping depends to some extent on the initial phase. Thus we have

$$\int_0^{\infty} [e^{-kpt} \cos (pt + \iota)]^2 dt = \frac{1 - k \sin 2\iota + k^2(1 + \cos 2\iota)}{4kp(1 + k^2)}. \quad (17)$$

Hence, although we have hitherto been compelled, in one or two cases, to sacrifice rigour on minor points on account of insufficient data, the initial phase of a wave-train will hereafter always be taken account of when dealing with reflexions for which theory furnishes the value of the phase-change to be expected.

It may be seen from (17) that where $k=0.1$ the value of the integral varies with ι between limits having the ratio 11 to 9 approximately.

30. *Transmitted System.*—Let the condenser under examination be at a point on the line distant l cm. from its beginning at the oscillator, and let the electrometer be l_2 cm. beyond the condenser, *i. e.* $l + l_2$ from the beginning of the line. Take the origin of coordinates at the condenser, and let the potential-difference of the wires due to the incident wave-train be represented by ϕ_1 , where

$$\phi_1 = e^{-kp(t-x/v) - \sigma x} \cos p(t-x/v). \quad (18)$$

The σ here provides for the attenuation of the waves in their passage along the line. Its value has been previously determined experimentally.

The train incident at the condenser is accordingly

$$\phi_1 = e^{-kpt} \cos pt. \quad (19)$$

31. Now, owing to the irregularity of the sparks at the primary oscillator, it is necessary in the experimental examination of any condenser to alternate electrometer-readings with and without the condenser on the line; the bridge which absorbs all waves incident upon it being throughout in place at the end of the line.

We have therefore to determine theoretically the ratio y , of the mean reading d' with the condenser on the line, to the mean reading d with no condenser on. Now the electrometer-throw, as previously explained, is proportional to the time-integral of the square of the amplitude of the wave-train passing it. Hence, denoting by E the electrometer-constant, we have

$$Ed = e^{-2\sigma l_2} \int_{l_2/v}^{\infty} e^{-2kp(t-l_2/v)} \cos^2 p(t-l_2/v) dt$$

$$= e^{-2\sigma l_2} \int_0^{\infty} e^{-2kpt} \cos^2 pt dt,$$

or

$$4kp(1+k^2)e^{2\sigma l_2}Ed = 1+2k^2. \quad \dots \quad (20)$$

32. Consider now the throw d' obtained with the condenser on the line. Retaining the previous notation for the transmission and reflexion operators of the condensers we have for the wave-trains successively transmitted at the condenser the following series:—

First wave-train:	B	$e^{-kpt} \cos(pt + \beta),$	}	(21)
Second do.	CAB	$e^{-kpt-2l\sigma} \cos(pt + \gamma + \alpha + \beta),$		
Third do.	C^2A^2B	$e^{-kpt-4l\sigma} \cos(pt + 2\gamma + 2\alpha + \beta).$		

The formation of this series is easily traced by noting that each time a wave-train is incident upon the condenser, not only is a part transmitted but also a part is reflected, suffers attenuation along the line in its passage to the oscillator, is there reflected, and again suffers attenuation along the line before reaching the condenser a second time. These effects are all provided for in the above series, in which also the simplification is adopted of taking $t=0$ for each new arrival of a wave-train at the condenser.

33. We thus have, on taking the time-integrals of the squares of the successive trains, the following series:—

$$Ed'e^{2\sigma l_2} = B^2 \int_0^{\infty} e^{-2kpt} \cos^2(pt + \beta) dt$$

$$+ r^2 B^2 \int_0^{\infty} e^{-2kpt} \cos^2(pt + \beta + \kappa) dt$$

$$+ r^4 B^2 \int_0^{\infty} e^{-2kpt} \cos^2(pt + \beta + 2\kappa) dt$$

$$+ \dots + \dots + \dots, \quad \dots \quad (22)$$

where $r = CAe^{-2l\sigma}$ and $\kappa = \alpha + \gamma$.

Now all the above integrals fall under the type

$$\int_0^\infty e^{-2kpt} \cos^2(pt + \delta) dt = \frac{1 - k \sin 2\delta + k^2(1 + \cos 2\delta)}{4kp(1 + k^2)}. \quad (23)$$

Further, the series, to which (22) when integrated gives rise, are represented by

$$\begin{aligned} & \sin \phi + r^2 \sin \overline{\phi + \psi} + r^4 \sin \overline{\phi + 2\psi} + \dots \\ & = \frac{\sin \phi - r^2 \sin \overline{\phi - \psi}}{1 - 2r^2 \cos \psi + r^4} \dots \dots \dots \end{aligned} \quad (24)$$

Hence (22) is easily transformed to

$$\begin{aligned} & 4kp(1 + k^2) E d' e^{2\sigma t_2} \\ & = B^2 \left\{ \frac{1}{1 - r^2} - \frac{k}{D} (\sin 2\beta - r^2 \sin \overline{2\beta - 2\kappa}) \right. \\ & \quad \left. + \frac{k^2}{1 - r^2} + \frac{k^2}{D} (\cos 2\beta - r^2 \cos \overline{2\beta - 2\kappa}) \right\}; \quad (25) \end{aligned}$$

where $D = 1 - 2r^2 \cos 2\kappa + r^4$.

34. Now in the experimental case under consideration k is less than 0.1; we may therefore, for the order of accuracy aimed at, simplify by neglect of k^2 . Then dividing (25) by (20) gives

$$y = \frac{d'}{d} = B^2 \left\{ \frac{1}{1 - r^2} - \frac{k}{D} (\sin 2\beta - r^2 \sin \overline{2\beta - 2\kappa}) \right\}; \quad (26)$$

which is the working formula for comparison with the experimental results.

35. Regarding this expression physically, we may note that its essence is the factor B^2 , the square of the amplitude transmitted. The denominator $1 - r^2$ of the first term in the brackets is due to the repeated courings of the waves to and fro between the condenser and oscillator. Finally, the second term, which vanishes with k , or with β and κ , is a small correction whose existence is due to the fact that with a damped wave-train the electrometer-throw varies slightly with the phase at the head, as shown in Art. 29.

36. *Stationary Waves at Electrometer.*—Now suppose the electrometer to be at a point on the line distant l_1 cm. from its beginning at the oscillator, and let the condenser be at $l_1 + l_2 = l$ cm. from the beginning, *i. e.* l_2 cm. beyond the electrometer. This disposition is exhibited in fig. 1. Let the absorbing bridge be at the end of the line as before. Take the origin of coordinates at the electrometer, and let the

incident wave-train be represented by

$$\phi_1 = e^{-kp(t-x/v) - \sigma x} \cos p(t-x/v), \quad \dots \quad (27)$$

which accordingly becomes at the electrometer

$$\phi_1 = e^{-kpt} \cos pt. \quad \dots \quad (28)$$

The notation previously used for the various wave-trains and for the coefficients of reflexion and transmission will be retained, and the following abbreviations used:—

$$\begin{aligned} l_2/v &= t_2, & 2pl_2/v &= 2pt_2 = \theta, \\ Ae^{-2l_2\sigma} &= s, & \alpha + \gamma &= \kappa, \\ CAe^{-2l\sigma} &= r, & CAe^{-2l_1\sigma} &= r_1, \\ 1 - 2r^2 \cos 2\kappa + r^4 &= D, & 1 - 2r_1^2 \cos 2\kappa + r_1^4 &= D_1. \end{aligned}$$

37. Then we have as before, if d be the electrometer-throw with no condenser on the line,

$$Ed = \int_0^\infty [e^{-kpt} \cos pt]^2 dt,$$

whence

$$4kp(1+k^2)Ed = 1 + 2k^2, \quad \dots \quad (29)$$

or, neglecting k^2 ,

$$4kpEd = 1. \quad \dots \quad (30)$$

38. Now suppose the condenser placed on the line and consider the effect at the electrometer of a single interference of the initial wave-train incident on the condenser with that reflected from the condenser. This is obviously represented by the following integrals:—

$$\begin{aligned} & \int_0^{2t_2} \phi_1^2 dt + \int_{2t_2}^\infty (\phi_1 + \phi')^2 dt \\ &= \int_0^\infty \phi_1^2 dt + \int_{2t_2}^\infty \phi'^2 dt + 2 \int_{2t_2}^\infty \phi_1 \phi' dt \\ &= \frac{F_1 + G_1 + H_1}{4kp(1+k^2)}, \quad \dots \quad (31) \end{aligned}$$

where $\frac{F_1}{4kp(1+k^2)}$ represents the integral under which it is placed; and the same remark applies to G_1 and H_1 .

39. But here again, as in the transmitted system already dealt with, the wave-train first reflected at the condenser returns along the wires, suffering attenuation during its transit, is reflected at the oscillator, and is again attenuated in passing along the line to the electrometer. This second wave-train produces a second interference phenomenon, like that due to the initial wave already treated; but phase changes

have been introduced and the amplitude diminished. Evidently, then, to complete the account of what happens at the electrometer, and frame a theory of the throw d' to be expected, we need an infinite decreasing series of integrals of each of the three types given in (31) as due to the first interference effect.

40. All these integrals, when evaluated, have the same denominator; hence bringing that to the left side of the equation, we may write

$$4kp(1+k^2)Ed' = \left. \begin{aligned} &F_1 + G_1 + H_1 \\ &+ F_2 + G_2 + H_2 \\ &+ F_3 + G_3 + H_3 \\ &+ \dots \dots \dots \\ &+ \dots \dots \dots \\ &+ \dots \dots \dots \\ &= F + G + H; \end{aligned} \right\} \dots \dots (32)$$

where $F = F_1 + F_2 + F_3 + \dots$;

and the same applies to G and H .

41. In constructing the integrals for the first line, we have to note that the reflexion at the condenser and the return of the waves to the electrometer introduce the space coordinate $2L_2$ in two exponential factors and in the argument of the cosine, besides introducing the amplitude factor A and the phase change α .

Again, in passing down any one of the columns in (32) we have to affect each succeeding line by the factor r^2 , and introduce κ in the angles whose cosines are taken.

We thus obtain the following scheme of integrals:—

$$\left. \begin{aligned} Ed' = &\int_0^\infty e^{-2kpt} \cos^2 pt \, dt + s^2 \int_{2t_2}^\infty e^{-2kp(t-2t_2)} \cos^2 (p \cdot \overline{t-2t_2} + \alpha) \, dt \\ &+ 2s \int_{2t_2}^\infty e^{-2kp(t-t_2)} \cos pt \cos (p \cdot \overline{t-2t_2} + \alpha) \, dt \\ + r^2 \int_0^\infty &e^{-2kpt} \cos^2 (pt + \kappa) \, dt + r^2 s^2 \int_{2t_2}^\infty e^{-2kp(t-2t_2)} \cos^2 (p \cdot \overline{t-2t_2} + \alpha + \kappa) \, dt \\ &+ 2r^2 s \int_{2t_2}^\infty e^{-2kp(t-t_2)} \cos (pt + \kappa) \cos (p \cdot \overline{t-2t_2} + \alpha + \kappa) \, dt \\ &+ \dots \dots \dots + \dots \dots \dots + \dots \dots \dots \\ &+ \dots \dots \dots + \dots \dots \dots + \dots \dots \dots \end{aligned} \right\} (33)$$

to an infinite number of lines.

42. All the above integrals are included in the following typical form:—

$$\left. \begin{aligned} & \int_{2t_2}^{\infty} e^{-2kp(t-t_2)} \cos(pt + \delta) \cos(\overline{pt - 2t_2 + \delta + \epsilon}) dt \\ &= \frac{e^{-k\theta}}{4kp(1+k^2)} \left\{ \begin{aligned} & \cos(\theta - \epsilon) - k \sin(\theta + 2\delta + \epsilon) \\ & - k^2 (\cos \overline{\theta - \epsilon} + \cos \overline{\theta + 2\delta + \epsilon}) \end{aligned} \right\} \end{aligned} \right\} (34)$$

And the series to which the columns in (32) and (33) when evaluated give rise are of the type given in equation (24). The evaluation of (33) then yields

$$4kp(1+k^2)Ed' = F + G + H, \quad (35)$$

where

$$F = \frac{1}{1-r^2} - \frac{k}{D} r^2 \sin 2\kappa + \frac{k^2}{1-r^2} + \frac{k^2}{D} (1-r^2 \cos 2\kappa), \quad . (36)$$

$$\begin{aligned} G = s^2 \left\{ \frac{1}{1-r^2} - \frac{k}{D} (\sin 2\alpha + r^2 \sin \overline{2\kappa - 2\alpha}) \right. \\ \left. + \frac{k^2}{1-r^2} + \frac{k^2}{D} (\cos 2\alpha - r^2 \cos \overline{2\kappa - 2\alpha}) \right\}, \quad . . (37) \end{aligned}$$

$$\begin{aligned} H = 2se^{-k\theta} \left\{ \frac{\cos \overline{\theta - \alpha}}{1-r^2} - \frac{k}{D} (\sin \overline{\theta + \alpha} - r^2 \sin \overline{\theta + \alpha - 2\kappa}) \right. \\ \left. + \frac{k^2 \cos \overline{\theta - \alpha}}{1-r^2} + \frac{k^2}{D} (\cos \overline{\theta - \alpha} - r^2 \cos \overline{\theta + \alpha - 2\kappa}) \right\}. \quad (38) \end{aligned}$$

43. *Discussion of Interference Phenomena.*—Let us now consider the various features of this result and their physical interpretation. In equations (36) to (38) the values of F, G, and H are arranged in terms commencing with one of the order unity and proceeding by ascending powers of k . The terms involving k are all small as their coefficients are of the order unity, and k is less than 0.1 in the experimental case under examination. Those involving k^2 will be omitted finally as their coefficients are likewise of the order unity.

The presence of the terms in k is due to the fact, already discussed in art. 29, that the electrometer-throw is slightly affected by the phase at the head of a wave-train of given amplitude, period, and damping. They are therefore but small corrections to the main features of the case which are represented by the first terms only of each of the expressions in (36) to (38) for F, G, and H. The denominators of these terms supply the correction for the successive arrivals at the electrometer of wave-trains which have suffered reflexion at

the condenser and oscillator and passed to and fro along the line.

44. Let curves be imagined with l_2 , the distance between electrometer and condenser, as abscissæ, and F, G, and H as ordinates. It is then seen by inspection of (36) that the curve for F is practically a straight line parallel to the axis of abscissæ. This was to be expected on physical grounds, for it represents the effect at the electrometer due to all the positively-travelling waves. And they are almost independent of any change in the value of l_2 when that change is small compared with l_1 .

45. Similarly, on inspection of (37), we see that, apart from the small terms in k and the slight change of v with l_2 , the curve for G is a logarithmically drooping one. But the droop is very slight for $s^2 = A^2 e^{-4l_2\sigma}$. This again is what might be expected from physical considerations, since this term, G, is due to the return of the wave-train reflected at the condenser apart from interference effects.

46. Turning finally to equation (38), we see that the main features of H are those represented by the first term. This term consists essentially of two factors, one exponential and the other trigonometrical. The exponential factor here gives a much quicker droop than that in G, for we now have $se^{-k\theta}$ instead of s^2 simply as before.

47. The essential nature of H will be made clearer if we write the chief parts of its first term in full. Thus

$$2Ae^{-2kpl_2/v} \cos\left(\frac{2pl_2}{v} - \alpha\right) = h \text{ (say)}. \quad (39)$$

Let now a curve be plotted with h as ordinates and l_2 as abscissæ, and call this the *interference curve*, since it represents the essential features of the electrometer-throws due to interference of waves reflected by the condenser with those incident upon it. Then by inspection of (39) and comparison with equation (27), representing the incident wave-train, we have the following results:—

- (1) The interference curve is of *damped wave-form*.
- (2) The *wave-length* of the interference curve is *half* that of the incident wave-train.
- (3) The *logarithmic decrement per wave* of the interference curve is *equal* to that of the incident wave-train.
- (4) The *amplitude* of the interference curve is *double* the amplitude factor introduced by the condenser on reflexion.
- (5) The *phase change* exhibited in the interference curve compared with the incident wave-train is *equal in magnitude but opposite in sign* to that introduced by the condenser on reflexion.

48. It may be noted here also in corroboration of these results that, if we simplify to the case of a resistance-bridge of resistance infinity or zero and omit all small terms and corrections, we obtain Bjerknæs' expression for interference*.

Thus taking only the first terms of F, G, and H, omitting their denominators and the factor $e^{-2\sigma}$, and writing $A=1$, and $\alpha=0$ or π , we have

$$F + G + H = 2(1 \pm e^{-k\theta} \cos \theta), \quad \dots \quad (40)$$

which is equivalent to Bjerknæs' equation just quoted.

49. If we now simplify equations (35) to (38) by neglect of k^2 and divide by the corresponding equation (30), we obtain

$$y = \frac{d'}{d} = F + G + H, \quad \left. \begin{array}{l} \text{where} \\ F = \frac{1}{1-\gamma^2} - \frac{k}{D} \gamma^2 \sin 2\kappa, \\ G = s^2 \left\{ \frac{1}{1-\gamma^2} - \frac{k}{D} (\sin 2\alpha + \gamma^2 \sin 2\gamma) \right\}, \\ H = 2se^{-k\theta} \left\{ \frac{\cos \overline{\theta-\alpha}}{1-\gamma^2} - \frac{k}{D} (\sin \overline{\theta+\alpha} - \gamma^2 \sin \overline{\theta+\alpha-2\kappa}) \right\}. \end{array} \right\} \quad (41)$$

This is the general formula to the desired degree of accuracy.

50. *Reflected System.*—In order to realize an experimental arrangement by which the value of A, the amplitude factor on reflexion at the condenser, may be inferred as simply as possible, let l_2 be taken very large. The term H is then practically extinguished by its very small exponential factor. But, lest its value should still be appreciable, let two values of l_2 be used, viz.: $l_2 + \lambda/8$ and $l_2 - \lambda/8$, where λ is the wave-length of the incident waves. These values of l_2 will give to H opposite algebraical signs, and since H is here very small the difference between its values for each position will be quite negligible. Moreover the values of F and G are almost the same for $l_2 + \lambda/8$ and $l_2 - \lambda/8$. We may, accordingly, write as the working formula for the reflected system,

$$\text{mean } y = F + G, \quad \dots \quad (42)$$

the 'mean y ' in the experimental case being the arithmetic

* Wied. Ann. xlv. pp. 513-526 (1891). Equation near top of page 517.

mean of the ratios $\frac{d'}{d}$ obtained with $l_2 + \lambda/8$ and $l_2 - \lambda/8$, and F and G may be calculated from (41) as for l_2 simply.

51. *Detection of Phase Change of Reflected Waves.*—We have just noticed a method of practically extinguishing H to simplify the determination of A. Now to determine the phase change, α , we must take exactly the opposite course and make H paramount, since this term represents the interference phenomena which alone involve α except in a subordinate degree.

We therefore choose a number of values of l_2 differing by small amounts and ranging from zero to about two wavelengths of the interference curve.

Since in these cases l_2 is very small compared with l_1 (say 0 to 10 metres and 100 metres respectively), the variable $l = l_1 + l_2$ may be put equal to the constant l_1 without material loss of accuracy. Consequently r is replaced by r_1 and D becomes D_1 .

52. We thus obtain from (41), under these simplifications, our interference formula, viz. :—

$$y = \frac{d'}{d} = F + G + H,$$

where

$$F = \frac{1}{1 - r_1^2} - \frac{k}{D_1} r_1^2 \sin 2\kappa,$$

$$G = s \left\{ \frac{1}{1 - r_1^2} - \frac{k}{D_1} (\sin 2\alpha + r_1^2 \sin 2\gamma) \right\},$$

and

$$H = 2se^{-k\theta} \left\{ \frac{\cos \theta - \alpha}{1 - r_1^2} - \frac{k}{D_1} (\sin \theta + \alpha - r_1^2 \sin \theta + \alpha - 2\kappa) \right\}.$$

(43)

53. A further simplification is made in the actual calculation and plotting of the theoretical curve, by writing

$$H = \frac{2se^{-k\theta}}{1 - r_1^2} (1 + n) \cos (\theta - \alpha + \nu). \quad (44)$$

The small quantities n and ν are defined as functions of k , r_1 , and κ by the identity of these two expressions for H. Both n and ν vanish for $k=0$, and assume a simplified value for $\kappa=0$. The actual values of n and ν in any numerical case can be readily found with sufficient accuracy by the graphical composition of sine and cosine functions, the amplitudes being represented by the lengths of lines whose inclination denotes the relative phase of the respective vibrations.

54. *Interference by Reflexion from a Resistance.*—To obtain

the interference effect produced by an intermediate resistance-bridge placed on the line beyond the electrometer we have simply to introduce its constants from equation (11) into equation (43). This substitution gives

$$y = \frac{d'}{d} = F + G + H,$$

where

$$F = \frac{1}{1-r_1^2} - \frac{k}{D_1} r_1^2 \sin 2\gamma,$$

$$G = s^2 \left\{ \frac{1}{1-r_1^2} - \frac{k}{D_1} r_1^2 \sin 2\gamma \right\}, \quad (45)$$

and

$$H = 2se^{-k\theta} \left\{ \frac{\cos \overline{\theta + \pi}}{1-r_1^2} + \frac{k}{D_1} (\sin \theta - r_1^2 \sin \overline{\theta - 2\gamma}) \right\}$$

$$= \frac{2se^{-k\theta}}{1-r_1^2} (1+n) \cos (\theta + \pi + \nu).$$

For a no-resistance bridge this is further simplified by the amplitude factor being unity.

EXPERIMENTS.

55. *Positions of Condensers.*—For the transmitted system the condensers were placed at FF' (fig. 1), the distance SF being 59 metres $\pm \lambda/8$. These two distances were chosen to eliminate any error which would arise if interference occurred on the oscillator side of the condenser. This might conceivably take place between the head of a wave-train arriving at the condenser simultaneously with the departure of the tail of a previous train reflected there. To reduce this anticipated disturbance to a minimum, the distance SF was chosen of the order 60 m. in preference to any smaller distance. It is easily seen that if this interference was additive in one of the positions chosen, then it would be subtractive in the other, and both being small the arithmetic mean could be taken. From the tables of readings it may be noted that neither of these precautions was unnecessary.

56. In the reflected system the distance ED of the condenser beyond the electrometer, denoted by l_2 in the theory, was made 48 m. $\pm \lambda/8$; the two positions being again adopted to obviate any error due to interference. Here again the precautions were not in vain. The wave-length λ of the

incident waves was determined by Bjerknæs's method to be 8.5 m.

For the interference phenomena, observed in order to detect the phase change on reflexion, the distance ED was varied by half a metre from 0.75 m. to about 8.0 m. so as to furnish nearly two wave-lengths of the interference curve.

The methods of taking the readings and their results will be sufficiently understood from the following tables and accompanying curves. The three condensers used were chosen by reference to the curve in fig. 5 as likely to yield typical results.

57. *Large Condenser.*—Disks 15 centim. radius and placed 1 centim. apart.

(i.) *Transmitted System.* On taking seven readings without condenser on alternated with six readings with condenser on, the values were respectively of the order

$$\left. \begin{array}{l} d = 26.8 \text{ and } d' = 2.6 \\ y = \frac{d'}{d} = .097 \text{ nearly} \end{array} \right\} \dots \dots (46)$$

With such small readings as those here obtained for d' it cannot be professed that they are free from errors due to small variations of the zero, which is never quite steady and is always read before each throw is taken throughout all the experimental work.

(ii.) *Reflected System.* Two sets of 41 readings each were taken for this arrangement. The first gave

$$\text{mean } y = \frac{\text{mean } d'}{d} = 1.862. \dots \dots (47)$$

The second, in which the behaviour of sparks and electrometer was more regular, gave

$$\text{mean } y = \frac{\text{mean } d'}{d} = 1.986. \dots \dots (48)$$

This second set of readings is given in Table II. (p. 380).

(iii.) *Interference System.* Four sets of readings were taken with this arrangement of the apparatus. The last of these is given in Table III., and the points corresponding to all of them are plotted in fig. 6, a curve is then drawn through the mean position to represent as fairly as may be the result of all the readings.

TABLE II.—Reflected System for Large Condenser.

Electrometer-Throws, d , without Condenser on.		Electrometer-Throws, d' , with Condenser at l_2 beyond Electrometer.		Ratio of Throws, $\frac{d'}{d}$, for each position, viz.:	
Actual Throws.	Interpolated Means.	$l_2 =$ $48^m - \lambda/8.$	$l_2 =$ $48^m + \lambda/8.$	$l_2 =$ $48^m - \lambda/8.$	$l_2 =$ $48^m + \lambda/8.$
23	23	45		1.957	
23	22.5		42		1.867
22	22	44		2.000	
22	22		42		1.909
22	25	50		2.000	
28	25.5		50		1.961
23	24	49		2.042	
25	25		54		2.160
25	27.5	56		2.036	
30	29.5		58		1.966
29	29.5	60		2.034	
30	29		57		1.966
28	28	59		2.107	
28	28		55		1.964
28	26	54		2.077	
24	26		54		2.077
28	29	50		1.724	
30	28.5		49		1.719
27	24.5	50		2.041	
22	20.5		43		2.098
19					
Mean Values of Ratios				2.002	1.969
Whence Final Value or Mean of Means = 1.986.					

Note.—This set of observations occupied 2 hours 45 minutes, during which time the zero crept 22 scale-divisions in the positive direction, viz., from -32 to -10.

Since the amplitude factor of the wave-train reflected from this condenser is almost unity, a bridge of no-resistance, whose reflexion factor is exactly unity, was used as a comparison and to show the phase-difference between the two curves. Three sets of readings were taken with this bridge, the points and mean curve for which are plotted on fig. 7.

TABLE III.—Interference System for Large Condenser.

Electrometer-Throws, d , without Condenser on.		Condenser on Line.		Ratios, $\frac{d'}{d} = y$, of Throws with and without Condenser.
Actual Readings.	Interpolated Means.	Electrometer Throws, d' .	Distance, l_2 , of Condenser beyond Electrometer.	
33	30	29	0.75 m.	0.97
27	29.5	53	1.0	1.80
32	28.5	72	1.5	2.53
25	25.5	112	2.0	4.39
26	16*	67	2.5	4.19
16	17	64	3.0	3.76
18	18	48	3.5	2.67
18	19.5	32	4.0	1.64
21	22	29	4.5	1.32
23	25	82	6.25	3.28
27	27	86	7.0	3.19
27	26	64	7.5	2.46
25	22.5	48	8.0	2.13
20				

* A pause was made here to adjust balls of spark-gap in oscillator; hence the 26 is disregarded, and 16 taken as true reading.

Fig. 6.—Experimental Results:—Interference System for Large Condensers. First three sets of readings indicated by \cdot , \circ , and \dagger respectively. Fourth Set (Table III.) by \times .

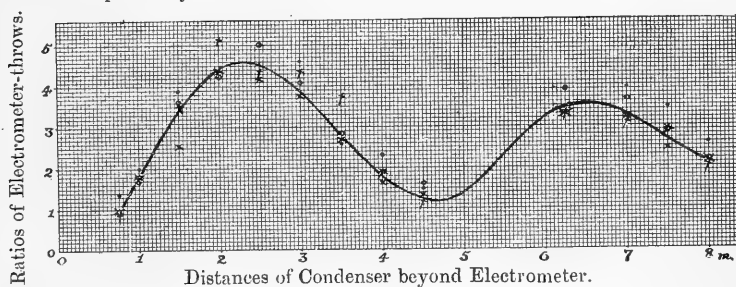
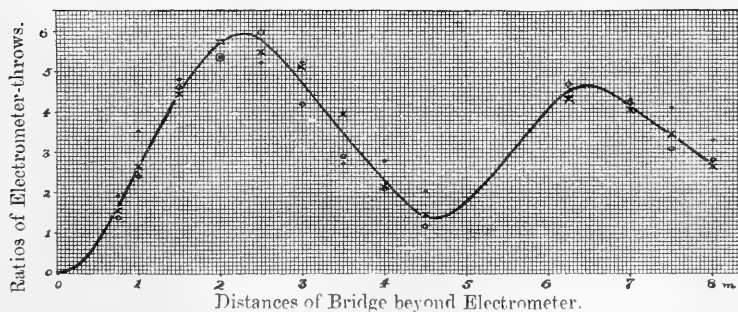

Fig. 7.—Experimental Results:—Interference System for Bridge of Negligible Resistance. Three sets of readings indicated by \cdot , \circ , and \times respectively.



58. *Medium Condenser*.—Disks 9 centim. radius and placed 1 centim. apart.

(i.) *Transmitted System*. The readings for this arrangement result in the ratio

$$\text{mean } y = \frac{\text{mean } d'}{d} = 0.349. \quad \dots \quad (49)$$

The readings are shown in Table IV.

TABLE IV.—Transmitted System for Medium Condenser.

Electrometer Throws, d , without Condenser on.		Electrometer Throws, d' , with Condenser at l beyond Oscillator, where		Ratios of Throws, $\frac{d'}{d}$, for each position, viz. :—	
Actual Throws.	Interpolated Means.	$l = 59^m - \lambda/8.$	$l = 59^m + \lambda/8.$	$l = 59^m - \lambda/8.$	$l = 59^m + \lambda/8.$
28	27.5	10		0.364	
27	30		10		0.333
33	31	11		.355	
29	29.5		10		.339
30	30	11		.367	
30	29.5		10		.339
29	28	9		.321	
27	25		7		.280
23	24.5	9		.367	
26	26		8		.308
26	25	9		.360	
24	23.5		8		.340
23	23	8		.348	
23	22.5		8		.356
22	22	8		.364	
22	22		7		.318
22	21	8		.381	
20	20		8		.400
20	20.5	7		.341	
21	20		8		.400
19					
Arithmetic Means.....				0.357	0.341
Whence Mean of Means = 0.349.					

(ii.) *Reflected System*. For this arrangement two sets each of 41 readings were taken. The first set gave

$$\text{mean } y = \frac{\text{mean } d'}{d} = 1.523; \quad \dots \quad (50)$$

the second set gave

$$\text{mean } y = \frac{\text{mean } d'}{d} = 1.626; \quad (51)$$

the readings being contained in Table V.

TABLE V.—Reflected System for Medium Condenser.

Electrometer-Throws, d , without Condenser on.		Electrometer-Throws, d' , with Condenser at l_2 beyond Electrometer.		Ratio of Throws, $\frac{d'}{d}$, for each position.	
Actual Throws.	Interpolated Means.	$l_2 =$ $48^m - \lambda/8.$	$l_2 =$ $48^m + \lambda/8.$	$l_2 =$ $48^m - \lambda/8$	$l_2 =$ $48^m + \lambda/8.$
25	25	42		1.680	
25	26		42		1.615
27	26.5	46		1.736	
26	28.5		53		1.860
31	29.5	55		1.864	
28	29		50		1.724
30	31	54		1.742	
32	33		54		1.636
34	33.5	52		1.552	
33	33		50		1.515
33	32	51		1.594	
31	30.5		47		1.541
30	30	49		1.633	
30	30		47		1.567
30	30	50		1.667	
30	29		44		1.517
28	28.5	42		1.474	
29	28		44		1.571
27	26.5	42		1.585	
26	23		33		1.435
20					
Arithmetic Means.....				1.653	1.598
Whence Mean of Means = 1.626.					

(iii.) *Interference System.* For this disposition of the apparatus four sets of readings were taken. One of these is given in Table VI. On fig. 8 are plotted the points from all the readings, and the curve through their mean position is shown also.

TABLE VI.—Interference System for Medium Condenser.

Electrometer-Throws, d , without Condenser on.		Condenser on Line.		Ratios, $\frac{d'}{d} = y$, of Throws with and without Condenser.
Actual Throws.	Interpolated Means.	Electrometer Throws, d' .	Distances, l_2 , of Condenser beyond Electrometer.	
37	36.5	22	m. 0.75	0.60
36	33	36	1.0	1.09
30	32	73	1.5	2.28
34	33.5	105	2.0	3.13
33	32.5	115	2.5	3.54
32	32	113	3.0	3.53
32	34	75	3.5	2.21
36	34.5	51	4.0	1.48
33	30.5	35	4.5	1.15
28	30.5	32	5.0	1.05
33	34.5	82	6.25	2.38
36	34.5	85	7.0	2.46
33	32.5	70	7.5	2.15
32	33.5	54	8.0	1.61
35				

Fig. 8.—Experimental Results. Interference System for Medium Condenser. The several sets of readings are respectively indicated by *, o, †, and x.

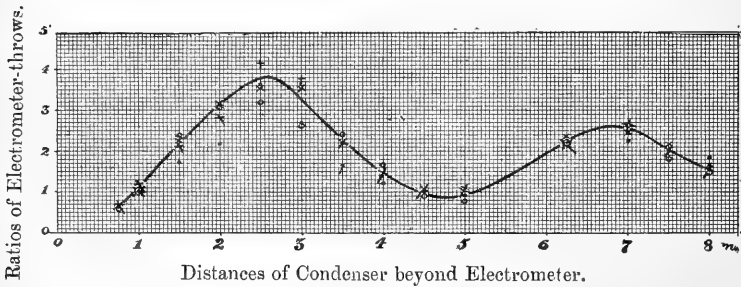

59. *Small Condenser.*—Disks 5 centim. radius and placed 1 centim. apart.

(i.) *Transmitted System.* For this arrangement the set of 41 readings shown in Table VII. was taken. These readings yield the result

$$y = \frac{d'}{d} = 0.868. \dots \dots \dots (52)$$

TABLE VII.—Transmitted System for Small Condenser.

Electrometer-Throws, d , without Condenser on.		Electrometer Throws, d' , with Condenser at l beyond Oscillator, where		Ratio of Throws, $\frac{d'}{d}$, for each position, viz.:	
Actual Throws.	Interpolated Means.	$l =$ $59^m - \lambda/8.$	$l =$ $59^m + \lambda/8.$	$l =$ $59^m - \lambda/8.$	$l =$ $59^m + \lambda/8.$
20	21	15		0.714	
22	22.5		15		0.667
23	24	20		.833	
25	23		18		.783
21	23	19		.826	
25	23.5		21		.894
22	22	19		.864	
22	22.5		19		.844
23	20.5	19		.927	
18	16		14		.875
14	16	14		.875	
18	18.5		14		.757
19	18	18		1.000	
17	17.5		16		.914
18	18.5	17		0.919	
19	17		17		1.000
15	16	14		.875	
17	17.5		14		0.800
18	15	16		1.067	
12	12		11		.917
12					
Arithmetic Means				0.890	0.845
Whence Mean of Means = 0.868					

(ii.) *Reflected System.* For this arrangement two sets each of 41 readings were taken. The first set gave

$$\text{mean } y = \frac{\text{mean } d'}{d} = 1.168. \quad \dots \quad (53)$$

The second set of readings is given in Table VIII. (p. 386) and yields the result

$$\text{mean } y = \frac{\text{mean } d'}{d} = 1.188. \quad \dots \quad (54)$$

(iii.) *Interference System.* With the apparatus arranged for observing the interference phenomena with this condenser, three sets of readings were taken. One of these is shown in Table IX. It will be seen to include readings for a *resistance-bridge* also. This bridge consisted of graphite markings upon a

TABLE VIII.—Reflected System for Small Condenser.

Electrometer-Throws, d , without Condenser on.		Electrometer-Throws, d' , with Condenser at l_2 beyond Electrometer.		Ratios of Throws, $\frac{d'}{d}$, for each position.	
Actual Throws.	Interpolated Means	$l_2 =$ $48^m - \lambda/8.$	$l_2 =$ $48^m + \lambda/8.$	$l_2 =$ $48^m - \lambda/8.$	$l_2 =$ $48^m + \lambda/8.$
37	32.5	37		1.138	
28	24.5		29		1.184
21	14.5	19		1.310	
* { 8	33.5		35	.	1.045
35	34	41		1.206	
33	31.5		37		1.175
30	32	39		1.219	
34	32		36		1.125
30	31.5	40		1.270	
33	33.5		38		1.134
34	31.5	39		1.238	
29	31		37		1.194
33	32.5	40		1.231	
32	33		37		1.121
34	32.5	39		1.200	
31	32.5		38		1.169
34	33.5	39		1.164	
33	33		37		1.121
33	32.5	41		1.262	
32	32		40		1.250
Arithmetic Means				1.224	1.152
Whence Mean of Means is				1.188.	

* The balls of the spark-gap of the primary oscillator were adjusted between these two readings.

half disk of ground glass 3 inches diameter, and was made of a resistance of 23.5 ohms, the value calculated to give the same amplitude factor on reflexion as the condenser now in use. This resistance was tested, and if necessary adjusted to 23.5 ohms, immediately before each time it was used.

Table X. gives a summary of the results, for both condenser and resistance-bridge, of all three sets of readings. From the mean values thus obtained the experimental curves for condenser and resistance-bridge are plotted in fig. 9.

Fig. 9.—Interference Systems for Small Condenser and for Bridge of 235 ohms Resistance. Experimental results in full lines, theoretical curves in broken lines. C and c denote curves for Condenser. B and b denote those for Bridge.

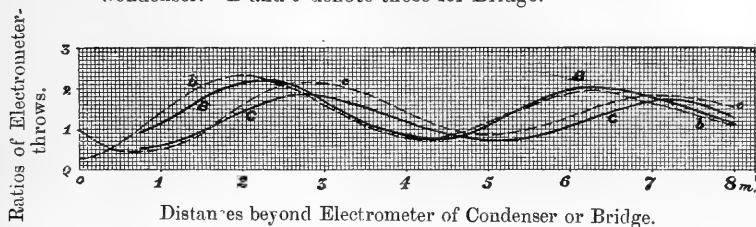

TABLE IX.—Interference System for Small Condenser and Corresponding Resistance Bridge.

Electrometer-Throws, d , without either Condenser or Resistance Bridge on.		Electrometer-Throws, d' , with apparatus at l_2 beyond Electrometer, viz. :—		Values of the Distance l_2 beyond Electrometer at which Condenser or Resistance Bridge is placed.	Ratios of Throws, $\frac{d'}{d}$, obtained with	
Actual Throws.	Interpolated Means.	Condenser on Line.	Resistance Bridge on Line.		Condenser.	Resistance Bridge.
27	26	34	27	m.		
25	26	42	39	8.0	1.31	1.04
27	25	42	43	7.5	1.62	1.50
23	24.5	31	48	7.0	1.68	1.72
26	26	19	27	6.25	1.27	1.96
26	25.5	22	19	5.0	0.73	1.04
25	24	30	20	4.5	0.86	0.75
23	23.5	40	25	4.0	1.25	0.83
24	23	43	41	3.5	1.70	1.06
22	22	39	45	3.0	1.87	1.78
22	22	30	43	2.5	1.77	2.05
22	19	18	35	2.0	1.36	1.95
16	14	10	14	1.5	0.95	1.84
12	13.5	8	12	1.0	0.71	1.00
15				0.75	0.59	0.89

TABLE X.—Summary of Results for Interference System with Small Condenser and Corresponding Resistance Bridge.

Ratios, $\frac{d'}{d}$, with the Condenser on the Line.				Values of the Distances l_2 beyond Electrometer at which Condenser or Resistance Bridge is placed.	Ratios $\frac{d'}{d}$, with the Resistance Bridge on the Line.			
Separate Values.		Means.	Means.		Separate Values.			
(A)	(B)	(C)		m.		(C)	(B)	(A)
0.526	0.39	0.59	0.50	0.75	0.90	0.89	0.89	0.912
.604	.48	.71	.60	1.0	1.11	1.00	1.13	1.208
.898	.95	.95	.93	1.5	1.76	1.84	1.87	1.551
1.333	1.57	1.36	1.42	2.0	2.05	1.95	2.03	2.157
1.885	1.56	1.77	1.74	2.5	2.15	2.05	2.10	2.308
1.738	1.79	1.87	1.75	3.0	1.45	1.78	1.36	1.639
	1.59						1.02	
1.486	1.20	1.70	1.46	3.5	1.19	1.06	1.13	1.371
1.206	1.50	1.25	1.38	4.0	0.97	0.83	1.11	0.971
0.812	0.93	0.86	0.87	4.5	0.81	0.75	0.96	0.719
.926	.68	.73	.78	5.0	1.05	1.04	1.03	1.074
1.309	1.24	1.27	1.27	6.25	2.02	1.96	1.97	2.145
1.569	1.66	1.68	1.64	7.0	1.75	1.72	1.87	1.662
1.636	1.73	1.62	1.66	7.5	1.45	1.50	1.48	1.364
1.118	1.45	1.31	1.29	8.0	1.15	1.04	1.18	1.235

The letters (A), (B), and (C) at the heads of the columns of separate values show corresponding sets of readings for Condenser and Resistance-bridge.

COMPARISON OF THEORY AND EXPERIMENT.

60. *Transmitted and Reflected Systems.*—The comparison of theoretical and experimental results for the transmitted and reflected systems of all three condensers is exhibited in Table XI.

The data for the theoretical values of the ratios are as follows.

The Reflexion and Transmission Constants for the three condensers are those given in fig. 5 and in the lower part of Table I.

The Amplitude Factor, C, for the oscillator is taken as 0.716 from the experiments * made in 1898 on the very line now in use.

The Attenuation Constant, σ , was also taken, from the

* "Attenuation of Electric Waves along a Line of Negligible Leakage," Phil. Mag. Sept. 1898. See in Table II. (p. 301) the value of ρ , which is the C of the present notation.

experimental determinations of the paper just quoted, as equal to 0.0000130.

The Phase-change, γ , introduced by the oscillator is calculated theoretically as equal to $-23^\circ 28'$.

Other data are :—

$Lv = 56 \times 10^{10}$ c.g.s. E.M. units (calculated and verified experimentally).

$k = 0.0955$ as determined experimentally.

$p = 2\pi v/\lambda = 1.96 \times 10^8$ radians per second as determined experimentally.

TABLE XI.—Comparison of Theory and Experiment for Transmitted and Reflected Systems of all three Condensers.

Condenser and System of Waves observed.		Values of Ratios, $\frac{d'}{a}$, of Electrometer-Throws with and without Condenser.		
		Calculated by Approximate Theory from equations (26) and (42).	Experimentally determined Values.	Calculated by Approximate Theory with corrections from equations (56) and (57).
Large.	Transmitted.	0.079	0.097 (?)	0.108
	Reflected.	2.236	1.924	2.095
Medium.	Transmitted.	0.420	0.349	0.367
	Reflected.	1.924	1.574	1.754
Small.	Transmitted.	0.966	0.868	0.706
	Reflected.	1.330	1.178	1.178

61. It is seen on reference to Table XI. that there is a considerable discrepancy between the experimentally-determined values of the ratios of electrometer-throws and those calculated from the approximate theory. This theory, used as a first working approximation, takes $\iota = 0$ in the original incident wave-train $e^{-kpt} \cos(pt + \iota)$, and omits the exponential term introduced on reflexion at the condenser. This was done because the value of ι is unknown. Let us now determine the *maximum* correction needed to the above theory, the results of which are placed in the last column of Table XI. Assume for ι such values as to make for each condenser $\iota + \beta = 0$. This makes the coefficient of the exponential term a maximum. Further, let us suppose (what is not possible) that the coefficient of the exponential term retains its maximum value all through; *i. e.*, put $\iota + \beta + 2\kappa = 0$ or π , $\iota + \beta + 4\kappa = 0$ or 4π &c. for the successive reflexions and transmissions. In order to convert the time-integral of the square of the amplitude, on the approximate theory, to its true value when the exponential term is retained, let A^2 and B^2 be now replaced by ρA^2 and τB^2 respectively.

Then we shall have

$$\left. \begin{aligned} \rho &= \int_0^\infty [Ae^{-kpt} \cos(pt + \iota + \alpha) - B \cos(\iota + \beta)e^{-2pt/x'}]^2 dt \\ &\quad \div \int_0^\infty [Ae^{-kpt} \cos(pt + \iota + \alpha)]^2 dt, \\ \text{and} \\ \tau &= \int_0^\infty [Be^{-kpt} \cos(pt + \iota + \beta) - B \cos(\iota + \beta)e^{-2pt/x'}]^2 dt \\ &\quad \div \int_0^\infty [Be^{-kpt} \cos(pt + \iota + \beta)]^2 dt \end{aligned} \right\} (55)$$

where $\iota + \beta$ is to be written equal to zero.

Further, since ι has now a finite value, and different for each condenser, equations (26) and (42) need modifying by the introduction of ι . We thus obtain the following corrected equations:—

For the transmitted system:

$$y = \tau B^2 \left\{ \frac{1}{1-r^2} - \frac{k}{D} r^2 \sin 2\kappa \right\}; \quad \dots \quad (56)$$

and for the reflected system:

$$\text{mean } y = F + \rho G;$$

where

$$\left. \begin{aligned}
 F &= \frac{1}{1-r^2} - \frac{k}{D} (\sin 2\iota - r^2 \sin \overline{2\iota - 2\kappa}), \\
 \text{and} \\
 G &= s^2 \left\{ \frac{1}{1-r^2} - \frac{k}{D} (\sin \overline{2\iota + 2\alpha} - r^2 \sin \overline{2\iota + 2\alpha - 2\kappa}), \right\}
 \end{aligned} \right\} (57)$$

ρ and τ being defined by (55).

62. It is to be noted that these formulæ in *two* respects *over-correct* the original approximate expressions. *First*, they assume that the trigonometrical coefficient of the exponential term is a maximum for *every* successive incidence; and *second*, they assume that for each condenser $\iota + \beta = 0$, which necessitates a different ι for each case, whereas the wave-train launched along the line must have the same shaped head in each case. Thus the truth on the long-wave theory may be expected to lie between the values given in the first and third columns of Table XI.

63. In comparing the experimental values with the theory, the following points may be noted :—

- (1) In one case (in Table XI.) experiment and theory give identical values (last line).
- (2) In two cases the theory seems over-corrected (lines 1 & 5).
- (3) In three cases the correction to the theory fails to bring the values down to those experimentally determined.
- (4) Hence the outstanding discrepancy is on the side of slightly less reflected and less transmitted than theory predicts, though further experiments under a greater variety of conditions would be needed to establish this view of the case.
- (5) Turning now from the question of the amplitudes of the reflected and transmitted waves to that of the phase-change, α , introduced on reflexion, we see from figs. 9, 10, & 11 that the theoretical and experimental results are in fair agreement.

Fig. 10.—Interference Systems for Large Condenser and for Bridge of Negligible Resistance. Experimental results in full lines, theoretical curves in broken lines. C and c denote curves for Condenser; B and b denote curves for Bridge.

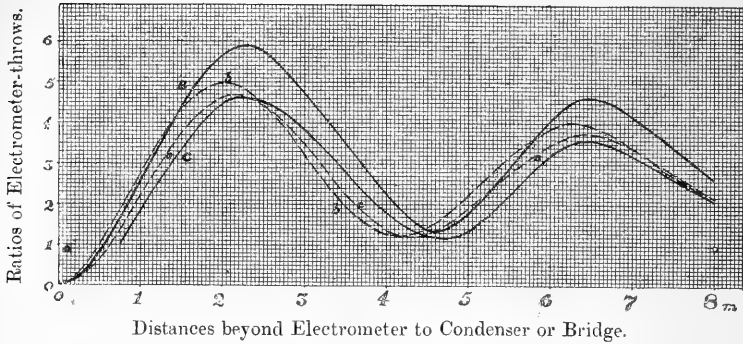
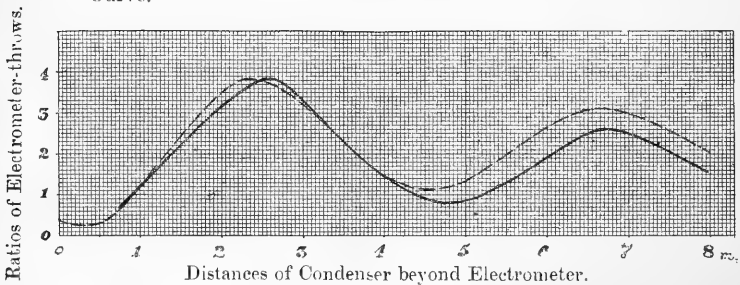

Fig. 11.—Interference System for Medium Condenser. The full line is the Experimental Curve, and the broken line is the Theoretical Curve.



Our indebtedness to the works of Oliver Heaviside, obviously great, has been increased by the receipt in MS. of supplementary elucidations with which Mr. Heaviside has favoured us. This invaluable help we here gratefully acknowledge.

Univ. Coll. Nottingham,
August 1899.

XXXVII. *On the Tabulation of certain Frequency-Distributions.* By W. F. SHEPPARD, M.A., LL.M.*

1. **W**HEN a measure X varies continuously, but with varying frequency, between limits X_0 and X_p (either or both of which may be at an infinite distance from the zero of the scale), the usual method of presenting the relative frequencies is to divide the whole range $X_p - X_0$ into equal intervals h , and to tabulate the number of cases in which X falls within each of the divisions of the scale so formed. When a large number of cases has been thus tabulated, the entries in the table are taken to represent the successive areas into which the figure of frequency is divided by a series of equidistant ordinates.

To decide whether the curve of frequency can be represented by an equation of a particular form, the arbitrary constants occurring in the equation are determined by calculating the mean, mean square, mean cube, . . . of the values of X , *i. e.*, by calculating the first, second, third, . . . moments of the figure of frequency about the ordinate corresponding to $X=0$. In the very common cases in which extreme variations are relatively rare, so that the curve of frequency has very close contact, at both extremities, with the base, the formulæ giving the moments of the figure of frequency, in terms of the areas bounded by equidistant ordinates, are very simple †. Nor is there any great difficulty in the calculations when the figure of frequency is terminated at either or both extremities by a finite ordinate; the problem then resolving itself into the quadrature of an area in terms of a series of ordinates ‡. There is, however, a large number of cases in which the figure of frequency is bounded at one or both extremities by an ordinate which is so great in comparison with other ordinates as to be practically infinite. Cases of the first kind, in which only one bounding ordinate is infinite, are especially common in economic statistics, and it is not necessary to give an example here §. Cases of the second kind, where both the bounding ordinates are infinite, are less common, but they do occur. Prof. Pearson has quoted the following as an example** :—

* Communicated by the Author.

† Proc. Lond. Math. Soc. vol. xxix. p. 368, formulæ (28).

‡ *Ibid.* p. 354, formula (4).

§ See K. Pearson, "Skew Variation in Homogeneous Material," Phil. Trans. vol. 183 (1895) A. pp. 396-403.

** Proc. R. S. vol. 62, p. 287.

Degrees of Cloudiness at Breslau, 1876-1885.

Degree	0	1	2	3	4	5	6	7	8	9	10
Frequency	751	179	107	69	46	9	21	71	194	117	2089

In these cases the moments of the figure of frequency cannot be conveniently expressed in terms of the areas bounded by equidistant ordinates, and some other method of tabulation should therefore be adopted.

2. The proper method, in all such cases, is that which is known as the *centile* (or "percentile") method. Instead of dividing the range of values of X into equal portions, and finding the corresponding areas of the figure of frequency, the area of the figure of frequency is to be divided into equal portions, and the corresponding values of X are to be found and tabulated. A division into ten equal portions, giving the "decile" values, will usually be sufficient; but a division into twenty or more is better. The values of X should be found, as far as possible, by direct observation; interpolation being only resorted to when the original measurements were so rough that several values of X fall into a class containing a particular centile.

When both the bounding ordinates are infinite, the centile method of classification is all that is required. When only one bounding ordinate is infinite, both methods must be adopted; the moment (of any order) of the figure of frequency must be calculated in two portions, the centile method being applied to the portion adjoining the infinite ordinate, and the ordinary method to the remainder.

3. The simplest case is that in which both bounding ordinates are infinite. Let Z denote the ordinate of the figure of frequency corresponding to abscissa X, the whole area of the figure of frequency being unity. Then the *m*th moment is

$$M_m = \int_{x_0}^{x_p} ZX^m dX. \dots \dots (1)$$

Now let A denote the area of the figure up to the ordinate Z. Then we have

$$A = \int_{x_0}^x Z dX, \dots \dots (2)$$

and therefore

$$Z = dA/dX. \dots \dots (3)$$

Hence, by (1),

$$\begin{aligned} M_m &= \int_{x_0}^{x_p} X^m \cdot dA/dX \cdot dX \\ &= \int_0^1 X^m dA. \dots \dots (4) \end{aligned}$$

Suppose the area to be divided into p equal portions, and let the corresponding values of X be $X_0, X_1, X_2, \dots, X_p$. Then the Euler-Maclaurin formula, applied to (4), gives

$$M_m = \left\{ \frac{1}{2} X_0^m + X_1^m + X_2^m + \dots + X_{p-1}^m + \frac{1}{2} X_p^m \right\} / p + \left[-\frac{B_1}{p^2 \cdot 2!} \frac{dX^m}{dA} + \frac{B_2}{p^4 \cdot 4!} \frac{d^3 X^m}{dA^3} - \dots \right]_{A=0}^{A=1} \dots \quad (5)$$

But, since the bounding ordinates $(dA/dX)_{A=0}$ and $(dA/dX)_{A=1}$ are infinite or very great, and the area of the figure is finite, the bounding values of the first few differential coefficients $dX^m/dA, d^3 X^m/dA^3, \dots$ are negligible; and we have therefore, as an approximate formula,

$$M_m = \left\{ \frac{1}{2} X_0^m + X_1^m + X_2^m + \dots + X_{p-1}^m + \frac{1}{2} X_p^m \right\} / p, \quad (6)$$

by means of which the value of M_m is very easily calculated.

If we require the mean square, mean cube, \dots of the deviation from the mean, we write

$$X' = X - M_1, \quad \dots \quad (7)$$

and we have, for the mean m th power of the deviation from the mean,

$$\mu_m = \left\{ \frac{1}{2} X_0'^m + X_1'^m + X_2'^m + \dots + X_{p-1}'^m + \frac{1}{2} X_p'^m \right\} / p. \quad (8)$$

When only one bounding ordinate is infinite, we have to apply the method to the calculation of the moments of the area extending from this ordinate to an ordinate which may or may not correspond to one of the centile values of X . The m th moment of this area is then given by the integral (4), but with a different upper (or lower) limit; and the formula (5) has to be modified, and the terms depending on differential coefficients have to be expressed in terms of differences.

4. To illustrate the accuracy of the formulæ (6) and (8), I have worked out the following two cases. The range in each case is taken to be from $X=0$ to $X=1$.

EXAMPLE I.

$$Z = \frac{2}{3\pi} (\sqrt{X} + \sqrt{1+X}) / \sqrt{X(1-X^2)}.$$

A.	X.	A.	X.
.00	.000 000 000	.55	.652 558 583
.05	.012 404 554	.60	.719 246 152
.10	.044 778 995	.65	.780 793 254
.15	.091 639 321	.70	.836 224 809
.20	.149 085 482	.75	.884 651 482
.25	.214 166 099	.80	.925 325 404
.30	.284 511 115	.85	.957 621 022
.35	.358 119 770	.90	.981 045 528
.40	.433 238 283	.95	.995 243 428
.45	.508 289 989	1.00	1.000 000 000
.50	.581 836 654		

	$M_1.$			$\mu_2.$ +			$\mu_3.$ -		
Calculated, $p=10$...	·545	529	242	·119	065	036	·007	406	699
Calculated, $p=20$..	·545	539	246	·119	053	606	·007	400	460
True value	·545	539	924	·119	052	858	·007	400	082
				$\mu_4.$ +			$\mu_5.$ -		
Calculated, $p=10$				·022	282	814	·003	116	676
Calculated, $p=20$				·022	275	637	·003	112	401
True value				·022	275	201	·003	112	161

EXAMPLE II.

$$Z = \frac{1}{12}X - \frac{5}{6} + \frac{1}{8}(1 - X) - \frac{3}{4}.$$

A.	X.			A.	X.		
·0	·000	000	000	·6	·697	374	666
·1	·000	063	969	·7	·886	710	165
·2	·004	034	329	·8	·975	442	372
·3	·041	904	643	·9	·998	408	477
·4	·180	187	494	1·0	1·000	000	000
·5	·430	159	709				

	$M_1.$			$\mu_2.$ +			$\mu_3.$ +		
Calculated, $p=10$...	·471	428	582	·171	772	175	·006	813	411
True value	·471	428	571	·171	772	196	·006	813	360
				$\mu_4.$ +			$\mu_5.$ +		
Calculated, $p=10$				·037	605	033	·003	280	297
True value				·037	605	134	·003	280	123

5. Various difficulties may arise in applying the method; but they will usually be due to imperfections in the original observations, rather than to defects in the method itself. The following special points may be noted:—

(i.) When the observations are very accurate, but few in number, there may be large gaps between successive values of X; and there may thus be a doubt as to the exact value to be assigned to any particular centile. But the doubt will only occur, in general, near the centre of the range; and the inaccuracy in M_1 will be subordinate to its “probable error,” while the inaccuracy in μ_2, μ_3, \dots will be very small.

(ii.) When, on the other hand, the values of X are only taken originally by very large intervals, there may be a good deal of difficulty in determining the centile values towards the extremities of the range. Thus, in the example given in § 1, the last class (cloudiness = 10) comprises more than half the total number of observations; and there are no direct data for the subdivision of this class. All we can do in these cases is to apply a suitable method of interpolation. Thus, in the above example, if we assume that the eleven "degrees" correspond to equal divisions of a scale, the range will be from $-\frac{1}{2}$ to $+10\frac{1}{2}$. Altering this, for convenience, to a range 0 to 11, and smoothing the observations (which are obviously incorrect at the upper end of the scale), I obtain* the following values of X :—

Per cent. of observations.	}	0	10	20	30	40	50	60	70	80	90	100
Degree of cloudiness.		.000	.112	.928	3.826	9.551	10.647	10.939	10.994	11.000	11.000	11.000

From these data the "frequency-constants" are easily calculated by means of (6) or (8).

(iii.) A further difficulty is often caused by ignorance of the exact bounding value or values of X . Prof. Pearson has already called attention † to this difficulty, especially in the case of economic statistics: and he points out to me that in the above example the first class includes all cases where there is no cloudiness at all, as well as those in which there is a cloudiness of less than $\frac{1}{20}$, while the last class includes all cases of total cloudiness, which cannot be graduated. Making no assumption as to the values of X_0 and X_p , I get the following arrangement :—

Per cent. of observations.	}	0	10	20	30	40	50	60	70	80	90	100
Degree of cloudiness.		.375	.394	.926	3.824	9.575	10.623	10.919	10.976	10.982	10.982	10.982

It will be seen that this gives a decidedly smaller range of values of X . The discrepancy between the two results illustrates the importance of making exact observations at the ends of the scale.

6. Finally, it may be observed that the adoption of this method of calculating the mean square, mean cube, . . . does not affect the formulæ for the probable errors in the frequency-

* The values of X are given to three decimal places, though the data are not really sufficient to give them to more than two places. The method of smoothing and interpolation is too complicated to be explained here.

† *Op. cit.* pp. 397, 398.

constants. Consider, for instance, the probable error in M_m , when both the bounding ordinates are infinite. Let N be the total number of observations. Then, if we knew the values of X exactly, the probable error in $M_m \equiv \Sigma X^m/N$ would be*

$$\cdot 67449 \dots \sqrt{(M_{2m} - M_m^2)/N}. \dots \dots (9)$$

The probable error in the expression on the right-hand side of (6) is

$$\cdot 67449 \dots \Omega_m/\sqrt{N}, \dots \dots \dots (10)$$

where

$$\begin{aligned} \Omega_m^2 = & \frac{2m^2}{p^4} \left\{ (p-1) \frac{X_1^{2m-2}}{2Z_1^2} + 2(p-2) \frac{X_2^{2m-2}}{2Z_2^2} + 3(p-3) \frac{X_3^{2m-2}}{2Z_3^2} \right. \\ & + \dots + (p-1) \frac{X_{p-1}^{2m-2}}{2Z_{p-1}^2} \\ & + (p-2) \frac{X_1^{m-1} X_2^{m-1}}{Z_1 Z_2} + (p-3) \frac{X_1^{m-1} X_3^{m-1}}{Z_1 Z_3} + \dots + \frac{X_1^{m-1} X_{p-1}^{m-1}}{Z_1 Z_{p-1}} \\ & + 2(p-3) \frac{X_2^{m-1} X_3^{m-1}}{Z_2 Z_3} + 2(p-4) \frac{X_2^{m-1} X_4^{m-1}}{Z_2 Z_4} + \dots + 2 \frac{X_2^{m-1} X_{p-1}^{m-1}}{Z_2 Z_{p-1}} \\ & + 3(p-4) \frac{X_3^{m-1} X_4^{m-1}}{Z_3 Z_4} + 3(p-5) \frac{X_3^{m-1} X_5^{m-1}}{Z_3 Z_5} + \dots + 3 \frac{X_3^{m-1} X_{p-1}^{m-1}}{Z_3 Z_{p-1}} \\ & \vdots \\ & \left. + (p-2) \cdot 1 \cdot \frac{X_{p-2}^{m-1} X_{p-1}^{m-1}}{Z_{p-2} Z_{p-1}} \right\} \dots \dots \dots (11) \end{aligned}$$

We may regard (11) as the approximate expression, by a quadrature-formula, of a more accurate value of Ω_m^2 . This value is to be found by making p infinite, which gives

$$\begin{aligned} \Omega_m^2 = & 2m^2 \int_0^1 A \frac{X^{m-1}}{Z} \left\{ \int_A^1 (1-A) \frac{X^{m-1}}{Z} dA \right\} dA \\ = & 2 \int_{X_0}^{X_p} A \cdot m X^{m-1} \left\{ \int_X^{X_p} (1-A) \cdot m X^{m-1} dX \right\} dX; \end{aligned} \quad (12)$$

and it is not difficult to show that this last expression is equal to

$$M_{2m} - M_m^2,$$

which agrees with (9).

* For the method of finding the probable errors considered in this section, see Phil. Trans. vol. 192 (A) 1898, pp. 124 seqq.

XXXVIII. *The Chemical and Geological History of the Atmosphere.* By JOHN STEVENSON, M.A., F.I.C.*

[Continued from p. 323.]

ANOTHER line of inquiry that has some bearing on our subject is provided by studying the rate of growth of vegetation. Sixty years ago Liebig made or obtained estimates regarding the amount of dry wood produced per acre per annum on average forest-land, of dry hay on meadow-land, of straw and corn on arable land, and also of beetroot on arable land. The results were very similar in all cases when reduced to dry substance, and were nearly equivalent to 2 tons of dry wood, or dry hay, &c. per English acre per annum. Lord Kelvin, in his address on the Age of the Earth, thinks this is too high an estimate to take as an average for the whole earth—he thinks it is “much higher than the average activity of vegetable growth on land and sea.” But if we call the average rate over the land-surface of the earth only half of the above estimate of Liebig’s, and leave the sea out of account altogether, we shall probably not err on the side of making too high an estimate, for though a large proportion of the earth’s surface is covered by deserts, there are large areas in tropical regions where the luxuriance is very much greater than that of the above estimate, and besides there is a very considerable growth of vegetable matter in the sea which we are leaving out of account. Let us also suppose that the dry wood, hay, &c. contain on the average 40 per cent. of carbon, and that the oxygen and hydrogen constituting the bulk of the remaining 60 per cent. are chemically equivalent to each other, that is to say, that they are present in the proportions which would form water. At this rate of growth (viz. 1 ton of dry wood &c. per acre), there would be 0·4 ton of carbon per acre per annum separated from atmospheric carbonic acid, or 256 tons per square mile per annum. If we now take the land-surface of the earth at 50,000,000 square miles, this makes a total quantity of 12,800,000,000 (nearly 13 thousand million) tons of carbon per annum. If we next assume that all this carbon is deposited and preserved in the form of coal, and that the process goes on at the same rate year after year, it is easy to see that in rather less than 40,000 years we should have the 500,000,000,000,000 tons of coal that are equivalent to the whole of our free oxygen. But of course we know very well that by far the most of the vegetable matter now grown on the earth is soon re-oxidized into carbonic acid and water,

* Communicated by the Author.

partly by animal nutrition and respiration, partly by rapid combustion in fires, and very largely by eremacausis, or slow oxidation and decay under the influence of air and moisture. The proportion that escapes oxidation through being deposited under fairly aseptic conditions, as in peat bogs, or by being swept out to sea and deposited along with other matters beyond the reach of atmospheric oxygen, is relatively very small. We have no data to guide us as to its total amount, but if we call it 25,000,000 tons annually—this being, as we have seen, the quantity of coal that would have to be deposited annually to give us 500,000,000,000,000 tons in 20,000,000 years—the proportion of vegetable remains preserved in the form of coal would be equal to about the $\frac{1}{512}$ part of the total carbon separated from the atmosphere annually by vegetation. Again, if we call the annual production of coal 740,000 tons (the amount that would give us 500,000,000,000,000 tons in 680,000,000 years), we should have the $\frac{1}{17,000}$ part of the carbon separated by vegetation permanently preserved in the form of coal. Of these figures the latter ($\frac{1}{17,000}$) seems credible enough; and if the former ($\frac{1}{512}$) should seem to be rather high for modern times, it is by no means incredible when taken as an average for the whole of geological history. For if there was no free oxygen in the earth's primitive atmosphere, and we may fairly enough say that by hypothesis there must have been none if on the average 25,000,000 tons of coal have been annually deposited and permanently preserved for the last 20,000,000 years, then there could at first be no eremacausis or other oxidation of vegetable remains due to atmospheric oxygen; and therefore those who hold that there was no primitive free oxygen may confidently say that a much larger proportion of vegetable remains could be preserved then in the form of coal than is possible at the present day. Even without going so far as to postulate that there was no free oxygen, but simply by making the probable assumption that the percentage of free oxygen in the atmosphere was considerably less than it is now, and that the percentage of carbonic acid was considerably greater than it is now, it could be maintained that eremacausis and other modes of atmospheric oxidation were in all probability much less active than they are now, and therefore that a larger proportion of vegetable remains would be preserved as coal than is now possible. We may therefore conclude that though this line of inquiry, like our previous ones, does not give exact and definite results, it at least puts no serious difficulty in the way of making a high estimate of the world's supply of coal.

Our efforts so far have been directed specially to the object

of ascertaining the probable amount of the world's supply of coal, or at least of ascertaining whether a high estimate of the total carbonaceous matter of the earth—high enough to make it equivalent to our free oxygen—is at all credible. We think that the general results indicate that this high estimate is quite credible. But even supposing that the evidence pointed distinctly in the opposite direction—supposing that there was good reason to believe that there was not enough fuel of a carbonaceous nature to use up all our free oxygen, it would not follow that there must have been at least some free oxygen in the earth's primitive atmosphere. It is quite possible that a large quantity of organic matter may have been deposited in certain rocks, and may afterwards have disappeared while the free oxygen corresponding to it still remains in the free condition. For it is well-known that there is found distributed through many rocks a considerable amount of sulphide of iron, which is an eminently oxidizable substance. There is also little doubt but that it has, in the case of stratified rocks, been produced from oxide (or carbonate) of iron and sulphate of lime by the reducing action of carbonaceous matter derived from animal and vegetable remains. It may therefore, like coal, be regarded as a fuel of vegetable origin, and the amount of oxygen that would be required for its complete oxidation may be regarded as so much oxygen that has been separated from carbonic acid by the action of vegetation. We should therefore be justified, when estimating the free oxygen produced by vegetation on the earth, to include not only the oxygen corresponding to all the carbonaceous matter derived from animal and vegetable remains, but also the amount of oxygen corresponding to the sulphide of iron found in sedimentary rocks. We cannot give even an approximate estimate of the percentage of sulphide of iron in such rocks, but we know that it is fairly high—quite comparable with that of the organic or carbonaceous matter itself, and therefore of great importance in the question of the history of free oxygen.

A large amount of sulphide of iron is also found in metaliferous lodes or veins. Other metallic sulphides are also found in these veins, and, as is well-known, constitute the principal ores of lead, zinc, mercury, antimony, copper, and other metals. The circumstance that these ores consist principally of sulphides, and contain but little oxygen except in the upper part of the veins, where they have in all probability been oxidized by the action of air and water, indicates that there is, most probably, a deficiency of oxygen in the regions of the earth from which the material filling the lodes is derived. It is of course just possible that the ores or

metallic compounds were at first well oxidized, and were afterwards reduced to sulphides by the action of hydrocarbon gases or similar compounds derived from carbonaceous matter in the adjacent rocks. If this were the case, a considerable quantity of carbonaceous matter would be required to account for the total amount of sulphides in metalliferous veins. It would, however, be rather difficult to form an estimate, and it is possible that the amount required might not be so great as to be at all comparable with the whole of our free oxygen. But it is much more likely that the sulphides and similar compounds (selenides, arsenides, &c.) were present as such from the very beginning of the history of the lodes; that is, from the time when the metallic compounds and the accompanying materials were injected or otherwise conveyed into the veins; and as these materials have probably been derived from more deeply lying regions of the earth's crust, their composition points to a general deficiency of oxygen on the earth as a whole.

Reference may be made at this stage to the large quantities of petroleum and natural gas which are found in many places in the earth's crust. These may not be so great as to be comparable in amount with our total supply of coal, but still they probably constitute a by no means negligible quantity of oxidizable matter. If we hold the theory that they are entirely derived from animal and vegetable remains by destructive distillation, or by the molecular transmutation of fatty matters, the quantity is at least sufficient to add an appreciable amount of support to a high estimate of the world's supply of fuel derived from organic remains. And if we adopt Mendeleeff's theory that they have been formed by the action of steam or water on carbide of iron and other metallic carbides in hot interior regions of the earth, we must infer that there is a deficiency of oxygen on the earth relatively to the amount of oxidizable matter present.

The observations made by Prof. Tilden on the nature of the gases enclosed in granite and basaltic rocks, and quoted by Lord Kelvin himself, have a similar corollary. That is to say, if granite and basalt have been produced out of ancient sedimentary rocks, then there must have been an appreciable quantity of organic matter or "reducing" matter of some kind present in these rocks; while if they are derived from more primitive materials than sedimentary rocks, they go to indicate a deficiency of oxygen on the earth as a whole.

This question about the excess or deficiency of oxygen on the earth relatively to the amount of oxidizable matter present, is of course not identical with our main question regarding

the history of free oxygen, but it is closely related to it, and we will therefore discuss it separately for a little.

A simple calculation will show that our total free oxygen is only a small fraction of the total oxygen of the earth. In the sea alone, which weighs roughly 1,400,000,000,000,000 (fourteen hundred thousand million million) tons, and contains about 85 per cent. by weight of oxygen, there is nearly 1000 times as much oxygen as there is in the atmosphere. This oxygen is very nearly all in the combined condition, the free oxygen dissolved in sea-water being very small in amount, even when compared with the amount of atmospheric oxygen itself. Further, the crust, or solid envelope of the earth as known to geologists, is estimated to contain about 50 per cent. of its weight of oxygen, and all in the combined condition. Now if we suppose the crust having this average composition to be 10 miles thick, and its specific gravity to be about $2\frac{1}{2}$ times that of water, it will weigh about 10 times as much as the sea, and the oxygen contained in it will be about 6 times as much as that in the sea, or 6000 times as much as that in the atmosphere. It is quite clear therefore that the total amount of free oxygen in the world is very small when compared with that of combined oxygen. Therefore, if there is an excess or surplus of oxygen on the earth after satisfying the requirements of the elements for which it has an affinity, that surplus must be relatively a very small one.

But further still, if the whole earth, which weighs 1,200,000 times as much as the atmosphere, or 5,000,000 times as much as the free oxygen of the atmosphere, should contain 50 per cent. of oxygen throughout, then the total combined oxygen of the earth will be 2,500,000 times as much as the free. However, even if we assume that the earth is thoroughly oxidized throughout, this estimate will have to be modified considerably in order to bring it into better conformity with the well-known fact that the specific gravity of the earth as a whole is much higher than that of the crust or envelope with which we are acquainted. The principal substances which exist in the interior of the earth must therefore be much heavier than those found near the surface; but still if they are oxides, or oxygen compounds, we might reasonably expect them—still judging from the specific gravity of the earth—to contain roughly about 20 per cent. of oxygen. This would make the total combined oxygen of the earth 1,000,000 times as much as the free. That is to say, if the earth as a whole is composed of well-oxidized materials, it would have to contain something like this amount of oxygen; and whatever the exact figure may be, it is obvious that there

must be a truly wonderful degree of exactness in the adjustment of the amount of oxygen on the earth to the amount of oxidizable substances, if they balance each other down to the $\frac{1}{1,000,000}$ part of the total weight of either. Looked at from a purely abstract standpoint, the standpoint of mathematical probability, so very exact a degree of balancing is extremely improbable. We know practically nothing of the principles on which the various chemical elements are distributed on the earth and throughout the universe; but let us assume for the moment that there is no principle at all, or nothing more definite than chance. On this principle, or want of principle, the probability that the total amount of oxygen on the earth will amount to any particular figure is substantially equal to the probability that it will amount to any other figure, out of a practically infinite number of figures, which are limited only by the condition that they must be considerably less than the total weight of the earth itself—the limit being something like one-half or one-fifth of the weight of the earth. As the possible figures, all equally probable, are practically infinite in number, the chances against any one figure being the correct one are practically infinite. If, then, we do not know, even on the roughest approximation, the amount of oxygen on the earth, but have two theories regarding a particular terrestrial problem, one of which requires that the total oxygen on the earth should be exactly, or almost exactly, of a particular amount, viz., just a very little more than the amount that is equivalent to the total oxidizable matter on the earth; while the second theory admits of the amount of oxygen being anything at all within a very wide range—from a rough (but inadequate) equivalence to the total oxidizable matter down to a very small fraction—say the $\frac{1}{15000}$ part of that amount, then, obviously, the latter theory has on *a priori* grounds an incomparably greater probability of being the correct one. Clearly, therefore, the inference from the above line of reasoning is that there is a deficiency of oxygen on the earth relatively to the total amount of oxidizable matter.

The objection may be made that certain other elements, viz., chlorine, bromine, iodine, and fluorine—which have not much affinity for oxygen but which have a strong affinity for other elements, and may therefore be regarded as rivals to oxygen or substitutes for it—may possibly be present on the earth in large quantity. The reply to this is a simple one, viz., that they are met with to only a small extent (relatively speaking) on the surface of the earth; and even if they were present in much larger quantities deeper down, that circumstance would not materially affect the force of the above line of reasoning.

Instead of saying that there must be a nearly exact balancing of oxygen and oxidizable matter on the earth if there is an excess of oxygen at all, we should have to say that the total quantity of oxygen and of halogens has been adjusted with great exactness to the total amount of other elements—a position which is very similar to the one already discussed.

It may, however, be argued that though there should be a deficiency of oxygen on the earth, relatively to the other elements, it does not necessarily follow that there ever was a time when there was no free oxygen in the earth's atmosphere. According to usually accepted theories, the temperature of the earth was at one time very high—red, or possibly even white hot throughout. The temperature could therefore quite well have been above the dissociation-point of most oxides or oxygen compounds, and therefore the earth's supply of oxygen, or a large proportion of it, may have existed in the free condition. On cooling down it would unite with those elements for which it had the greatest affinity, and with which it came into most frequent contact; but being a gas it would all exist in the atmosphere, and would not come into intimate contact with the original liquid nucleus of the earth, which would probably consist principally of heavy metals, or heavy metals combined with more or less sulphur, silicon, carbon, nitrogen, &c. The oxygen would probably therefore combine first with the lighter and more oxidizable elements, *e. g.* silicon, carbon, aluminium, calcium, magnesium, potassium, and sodium; and owing to the great abundance of silicon, and its strong affinity for oxygen, a large quantity of silica, or of silicates, would be formed. It is quite possible, then, that before all the oxygen had passed into the combined condition, a thick layer of silicates would be formed which would prevent the remaining oxygen from getting access to the still oxidizable iron and other elements lower down.

This is quite a plausible theory; but still it does not quite surmount the balancing difficulty. Any one holding it will still have to admit that our total free oxygen bears only a very small ratio to the amount of combined oxygen on the earth; for the latter is, as we have seen, on the lowest possible computation, about 6000 times as much as the free. The earth's supply of oxygen has therefore combined to the extent of at least 99·98 per cent. of its total amount with oxidizable matters, and as there is still a considerable quantity of oxidizable matter within easy reach (geologically speaking) of the remaining oxygen, it is difficult to see why the oxygen should not all have gone into combination by this time, if it were not for the operation of some counteracting influence. It

is an altogether simpler and more credible hypothesis to suppose that the oxygen was all in the combined condition at one time; and even the additional supposition that there was a considerable amount of hydrogen or of hydrocarbon gases left over in the atmosphere after all the oxygen had gone into combination, is not at all incredible.

A theory or supposition of this kind is no doubt somewhat startling, but it is supported by solar and stellar analogy in the most emphatic manner. The sun and many other stars contain, as is well known, large quantities of free hydrogen gas, but no oxygen whatever has been found in any of them by spectroscopic examination. This, of course, may be due to the circumstance that oxygen, though present is, combined in forms which do not reveal themselves to the spectroscope, or that oxygen even when free is not readily observed in a flame by means of the spectroscope. However that may be, we know that there is a great abundance of free hydrogen on the sun and many stars, while not a trace of free oxygen has been observed with certainty as yet.

Another observation of the same kind is that of Sir W. de W. Abney, regarding the absorption spectra of the attenuated gases which are supposed to be present in interstellar space. He considered that his observations pointed to the existence of the vapour of benzene, a well-known hydrocarbon, in these highly vacuous regions.

But there is additional evidence of this kind, and evidence which brings the observation much nearer the earth itself, viz., the circumstance that meteorites have been found which contained occluded hydrogen. In all probability the meteorites which have fallen on the earth previously travelled round the sun in orbits not greatly differing from that of the earth, at least as regards the average distance from the sun. We should therefore, on the ordinary theories of the formation of the solar system, naturally expect them to contain roughly the same elements as the earth, and roughly also in the same proportion. Now it is well-known that meteorites frequently contain a large amount of metallic iron or iron carbides, and similar oxidizable substances. Compounds containing oxygen are no doubt also found, and sometimes in considerable quantity, but there is never enough oxygen present to completely oxidize all the other elements. The composition and mineralogical character of these compounds also seem to preclude the existence of free oxygen on the meteorites or the materials from which they are formed. Prof. H. Newton has made the significant observation that they are very similar to the minerals which are found on the earth in deep-seated

rocks, and that probably an essential condition to their formation is the absence of free oxygen and of water. When we also remember the large proportion of metallic iron or iron carbide that is usually found in meteorites, and that among the other constituents there are found sulphides, nitrides, and even phosphides—the last being a class of compound that has not been found on the earth at all in a properly telluric form—we can easily see that meteorites are very imperfectly oxidized, and probably never contained free oxygen.

If, therefore, the earth is analogous to the other members of the solar system with which we are best acquainted, viz. the sun itself and the meteorites which have fallen on the earth, it must obviously be very imperfectly oxidized—the oxygen present must be much less than that required for the complete oxidation of the other elements. It does not necessarily follow from this that there never was any free oxygen in the earth's atmosphere in primitive times; but it follows that there probably was a time, and possibly a long time, when there was none. On this hypothesis our present supply of free oxygen has been all produced by the action of sunlight on vegetation; and if we hold that the primitive atmosphere of the earth contained free hydrogen or hydrocarbon gases, then the amount of oxygen liberated by vegetation must have been even greater than that of our present free oxygen, for a large quantity may have been used up in oxidizing the hydrogen and hydrocarbon gases to water and carbonic acid.

The most important evidence on our general subject is probably that derived from the study of the amount of carbonaceous and other oxidizable matter due to vegetation which is found on the earth. Our information on this point is very imperfect as yet, but it indicates that a high estimate—an estimate which makes it equivalent to the free oxygen of the atmosphere—is quite possible, and even probable. We may expect that our information will become much more exact in course of time, and that it may yet enable us to give a decisive answer to the question before us; but we can say in the meantime that the available evidence indicates that the theory is quite credible that there was a time when there was no free oxygen on the earth.

[NOTE *added Sept. 25th.*—With reference to the argument on page 401 I may add that Ebelmen in his essay on the Decomposition of Silicates (published 1845) considers that the amount of iron pyrites existing on the earth is probably more than equivalent to the total free oxygen of the atmosphere.]

XXXIX. *The Annual March of Temperature.*

By R. J. A. BARNARD, M.A., Melbourne*.

THE accompanying curves give the results of an examination of the temperature for forty years at Melbourne, and were suggested by Rijkevorsel's work on European meteorological elements.

The process adopted was as follows:—The forty years' observations were divided into two groups, 1859–78 and 1879–98. In each group the average for each day is obtained and smoothed twice by replacing the temperature of each day by the mean of the five consecutive days of which the particular day is the middle. The results of the second smoothing are given.

An examination of the curves does not lead to such definite results as given by Rijkevorsel for Europe, but some striking correspondences are noticeable, the most marked being that at the end of March. In the second week of March it will be found that the temperature begins to drop rapidly, reaching a secondary minimum for each curve on the 19th. It then rises again to the extent of $2^{\circ}5$ during the next week, reaching a maximum on the 25th and 26th, the date being again the same for both. I have examined the four groups of ten years, and all the curves show the same minimum and maximum in March. The curves for the first three weeks of January, for the whole of April, and some other parts also show great resemblances, but in many other cases where the curves appear very similar the times of the secondary maxima and minima do not coincide sufficiently closely in time, and in some parts the maxima of one occur with the minima of the other.

The conclusions I am inclined to draw from my results are the following:—First, that the spells of weather are in all probability not so marked here as in Europe. If this is so the probable cause lies in the more uniform conditions of the southern hemisphere, tending to make the annual march more uniform and free from spells. Secondly, I do not think that a period of less than 40 years can give any real information about spells. For example, if one had only the first curve of the figure, the spells in June would seem to be quite as striking as that in March, yet the second curve is exactly opposite in the former case. Thirdly, I have no doubt that to establish the existence of spells the most satisfactory method is to take the observations of a particular place and divide them into groups and compare them as I have done, and that these groups should not be less than 20 years each.

* Communicated by the Author.

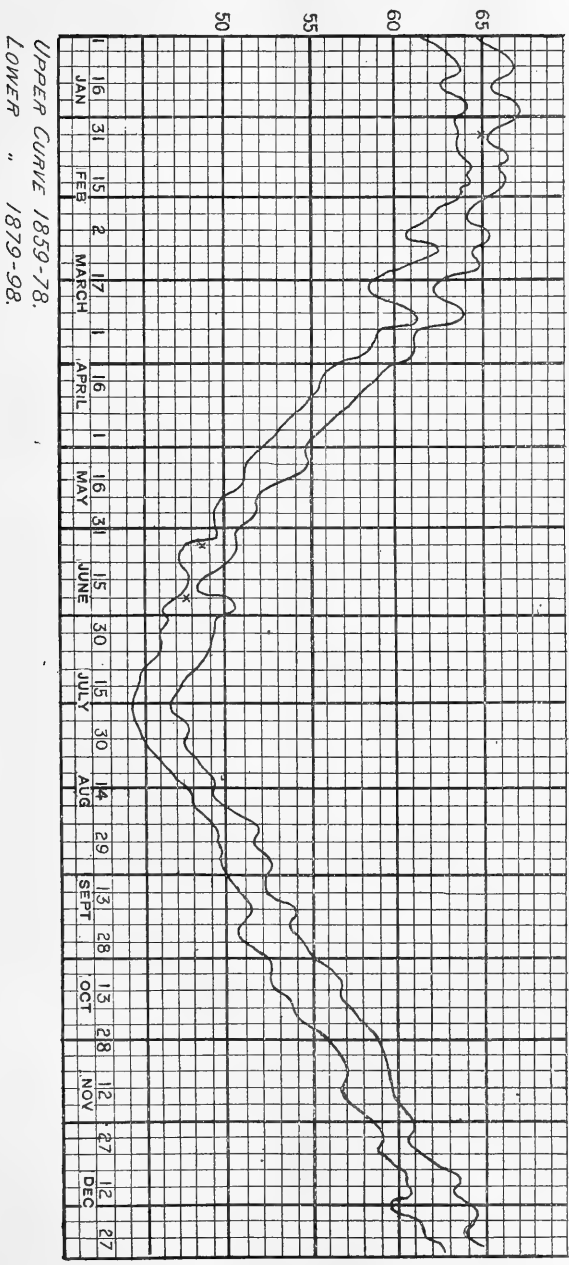

XL. Notes on the Measurement of some Standard Resistances.
By R. T. GLAZEBROOK, M.A., F.R.S., Director of the
National Physical Laboratory.*

THE problem of comparing together two nearly equal resistance-coils is a much simpler one than that of determining the resistance of a coil of 10, 100, or 1000 ohms in terms of the unit coils. There are various methods by which such comparisons may be made. I had occasion some little time back to determine the resistance of certain coils of 10, 100, and 1000 ohms. I made each determination purposely by two or more methods; and it may be useful to put the results on record with a view of indicating the accuracy which can be reached without any very elaborate precautions. The coils in question were all of platinum-silver with a temperature-coefficient of about $\cdot 00028$ per 1° C.; and by far the most important source of error is the uncertainty of the temperature.

The 10-ohm coils were measured in three different ways. The first (Method I.) was that employed in constructing the standards of the British Association, and is described in the Report of the B. A. Committee for 1883.

Three 3-ohm coils are wound on the same bobbin. The bobbin is enclosed in a box one face of which is of ebonite through which the six electrodes of stout copper rod project. By means of an arrangement of mercury cups these three coils can be placed in series or in multiple arc. I have acquired the habit of calling this box with its projecting legs the Beetle, and denoting its resistance when in multiple arc by the letter B.

Let the resistances of the three coils be $3 + \alpha$, $3 + \beta$, and $3 + \gamma$ respectively. Then

$$\begin{aligned} \frac{1}{B} &= \frac{1}{3 + \alpha} + \frac{1}{3 + \beta} + \frac{1}{3 + \gamma} \\ &= 1 - \frac{1}{9}(\alpha + \beta + \gamma) + \frac{1}{27}(\alpha^2 + \beta^2 + \gamma^2), \end{aligned}$$

omitting higher powers of the small quantities α , β , γ . Hence

$$B = 1 + \frac{1}{9}(\alpha + \beta + \gamma) - \frac{2}{81}(\alpha^2 + \beta^2 + \gamma^2 - \alpha\beta - \beta\gamma - \gamma\alpha).$$

Hence if α , β , and γ are nearly equal, the third term is

* Communicated by the Physical Society : read May 25, 1900.

very small, and we have very approximately

$$B = 1 + \frac{1}{9}(\alpha + \beta + \gamma).$$

Now it is comparatively easy to adjust the three 3-ohm coils to equality, and an accurate 3-ohm standard is not required.

Hence, if B' be the resistance of the combination when all the coils are in series, then

$$B' = 3 + \alpha + 3 + \beta + 3 + \gamma = 9B.$$

Or the resistance of the arrangement in series is very approximately 9 times that when in multiple arc.

The arrangement of mercury cups is shown in fig. 1. A number of holes about .75 centim. diameter are bored through

Fig. 1.

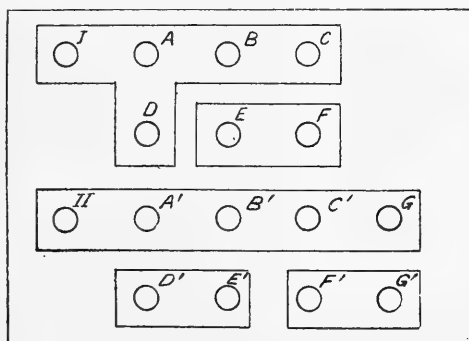

a sheet of ebonite. Thick strips of copper of the form shown in the figure are cemented to the under side of the ebonite, the surface of the copper in contact with the ebonite being amalgamated, and the cups thus formed contain mercury.

In the multiple-arc position the 3-ohm coils are connected with AA' , BB' , CC' respectively; in the series position they connect DD' , EE' , FF' , while a coil of 1 ohm is placed across GG' . The cups I., II. serve to connect the system to the bridge.

Let the resistance of the short rods used for this purpose be U , and the resistance of the 10-ohm coil whose value is required be X .

The first operation is to compare by Carey-Foster's method the Beetle in the multiple-arc position and a standard 1-ohm coil S ; let x_1 be the shift on the bridge-wire.

Then we have

$$B + U = S + x_1,$$

or

$$B = S + x_1 - U.$$

Next S is placed across the gap GG' and the Beetle moved into the series position; the combination is then compared with the 10-ohm coil; let x_2 be the shift. Then

$$\begin{aligned} X &= 9B + U + S + x_2, \\ &= 10S - 8U + 9x_1 + x_2. \end{aligned}$$

So that if U the resistance of the contact-pieces is known, the value of X is found in terms of S .

The chief source of error arises from the difficulty of maintaining the temperature of the Beetle sufficiently steady during the measurements. The consequences due to this can be reduced by taking a series of measurements in order, first with the Beetle in multiple arc, then with it in series. If a given coil be tested by this method at varying temperatures, the observations usually lie on a smooth curve to within about $0^{\circ}05$ C.

The method was I believe originally devised by Lord Rayleigh in order to construct a coil of 25 ohms from one of 1 ohm. He employed five coils of 5 ohms each; it is the method by which the 10-ohm coils of the Association were constructed.

The other methods employed to determine the 10-ohm coils were both build-up methods. Messrs. Nalder, Bros., kindly put at my disposal a number of boxes arranged as described below.

Each box contained five coils in series and of the values 1, 1, 2, 3, and 4 units. The two ends of the whole series were permanently connected to two mercury cups, and each junction of two consecutive coils was connected to a mercury cup.

Thus the resistance of the series is 10 times that of the first coil.

The coils are enclosed in a wooden box, and are numbered 1 *a*, 1 *b*, 2, 3, 4; the unit may be either 1, 10, 100, or 1000 ohms.

The arrangement may be used in two different ways; it is shown diagrammatically in fig. 2.

Method II.—Coil 1 *a* is connected by contact-pieces of known resistance to the Carey-Foster bridge and compared with a known standard S . The value 1 *b* is found similarly.

Then S is replaced by an ordinary box of coils, and coil 2 of this box is compared with 1 *a* + 1 *b* in series; coil 2 of the

build-up contrivance is then compared with coil 2 of the box, and hence with $1a + 1b$. The comparisons are all done on the Carey-Foster bridge, so that ultimately each coil of the build-up box is known in terms of S and the bridge-wire. Finally, the unknown coil X is compared with $1a + 1b + 2 + 3 + 4$.

Fig. 2.

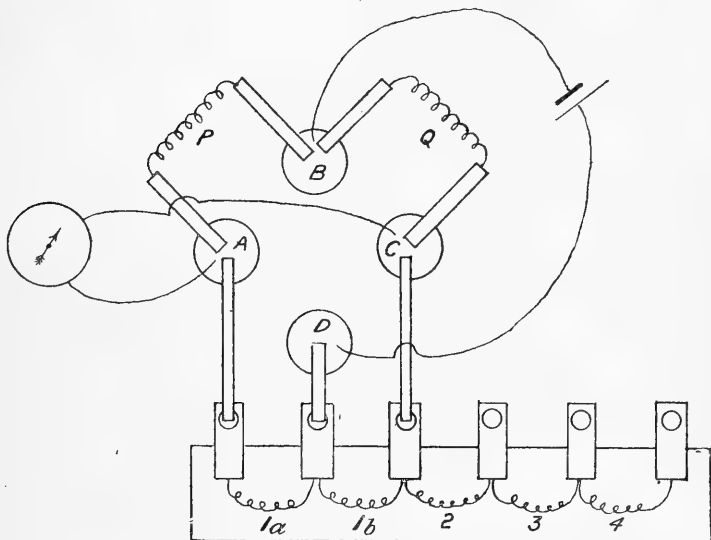

The objection to this method is that it takes some time, and temperature changes lead to difficulty.

Method III.—Although Method II. is applicable to boxes in which the unit is greater than one ohm, it becomes difficult of application unless the wire of the Carey-Foster bridge can be altered. In my bridge the resistance of 1 millim. is $\cdot 00005$ ohm, and the difference between two coils of 50 or 100 ohms, nominal value, may easily be greater than the whole bridge-wire resistance.

It was desirable therefore to devise a method of measuring the resistance of the coils of the box which did not involve the Carey-Foster bridge for the higher resistances.

Two 10-ohm coils P and Q were taken and their difference accurately found on the Carey-Foster bridge; thus, the difference being small, the ratio P/Q is known accurately. The value of the coil $1a$ is also found on the Carey-Foster bridge.

Four mercury cups, A, B, C, D (fig. 2), are arranged at the corner of a square; the gaps AB, BC contain the coils P, Q

respectively. The coil $1a$ is connected by suitable pieces to A and D, and $1b$ to D and C respectively.

The resistances of the connecting-rods should be equal.

A battery connects B and D, a galvanometer connects A and C.

If P is equal to Q and $1a$ to $1b$, then there will be a balance; if this is not the case, a balance can be found by shunting P or Q with a resistance W. This resistance need not be accurately known. Thus $1b$ can be found in terms of $1a$. Then $1b + 1a$ can be placed between A and D, and 2 between D and C. Hence 2 can be found and so on. In this manner finally the value of the whole is known.

In the experiments referred to the values of certain standard 10-ohm coils were determined, in all cases by two at least of these methods, with a view to testing the accuracy of the determination. Table I. gives the result.

TABLE I.

Method I.	Method II.	Method III.	Difference expressed as a fraction of the whole.
10·0036	10·0039		-·00003
10·0044	10·0041		+·00003
10·0068		10·0070	-·00002
9·9950		9·9946	+·00004
9·9923		9·9921	+·00002
9·9906		9·9903	+·00003
9·9911		9·9909	+·00002

The first method appears to give slightly higher results than the others, but the differences, with one exception, would be caused by an uncertainty of 0·1 C., and no attempt was made to read the thermometers to a greater accuracy than this.

In the case of the 100 and 1000-ohm coils Method III. was used; and also a fourth method (Method IV.), that ordinarily employed in testing such coils for the B. A. Committee.

A bridge is formed consisting of the 100-ohm coil to be tested, two 10-ohm coils, and a unit; then by shunting one arm as in Method III., by a resistance which does not require

to be accurately known, the value of the 100-ohm coil can be found. In this way the following results were obtained :—

TABLE II.

Method IV.	Method III.	Difference expressed as a fraction of the whole.
100·017 100·020 } .	100·022	-·00003
100·045 100·047 } .	100·045	+·00001
1000·37 1000·36 } .	1000·31	+·00005
1000·51 1000·52 } .	1000·50	+·00001

In one case only is the difference greater than that due to an error in temperature comparable with $0^{\circ}\cdot 1$ C., and it will be noticed that the difference between two determinations of the same coil by Method IV. is comparable with the differences between the results of the two methods.

It thus appears that to an accuracy of some two or three parts in one hundred thousand, the various methods lead to the same results. To reach a higher accuracy would involve, if the coils were of platinum-silver, the knowledge of their temperature to less than $0^{\circ}\cdot 1$ C. The end might, however, better be attained by employing manganin or some such alloy.

Possibly this paper may serve a useful purpose by calling attention to the various methods which may be employed to build up multiples of a unit resistance and by giving some account of the accuracy attained.

A source of uncertainty in resistance measurements is due to the fact that the coils are heated by the current. It is clear that the currents traversing the 1000-ohm coil in the two arrangements described above were different; the concordance of the results tends to show that the error due to heating was in these experiments negligible.

APPENDIX.—*Added Sept. 18, 1900.*

In the theory of Method I. given above, no notice is taken of the fact that the length of copper connecting each of

the three 3-ohm coils to the bridge is different. It is easy to do this thus:—Let the resistance between each of the adjacent cups, such as I to A, A to B, B to C &c. be y ohms. Then the resistances of the 3-ohm coils in the multiple arc position are $3 + \alpha + 2y$, $3 + \beta + 4y$, and $3 + \gamma + 6y$ respectively, and neglecting squares of small quantities as before, we have

$$B = 1 + \frac{1}{3}(\alpha + \beta + \gamma + 12y).$$

While the series value of the coils is easily seen to be

$$\begin{aligned} B' &= 9 + \alpha + \beta + \gamma + 9y \\ &= 9B - 3y. \end{aligned}$$

The value of y is found by connecting I. and II. to the bridge, short-circuiting the other gap of the bridge and then short-circuiting in turn AA', BB', CC', and finding a series of balance-points. The difference of the readings thus found gives a . In the case of the apparatus used the mean of a number of readings gave

$$a = \cdot 4 \text{ bridge-wire divisions} = \cdot 00002 \text{ ohms.}$$

So that instead of putting $B' = 9B$ in reducing the results it would have been more accurate to write $B' = 9B - \cdot 00006$. The correction is too small to be of importance. I also found that at a temperature of 16° the value of the 3-ohm coils were respectively 3·0038, 3·0026, and 3·0027.

XLI. *Experiments on the Elasticity of Wires.* By H. E. WIMPERIS, B.A., Whitworth Scholar, Late Salomons and Foundation Scholar of Caius College, Cambridge, Demonstrator in the University Engineering Laboratory*.

IN the Philosophical Magazine for February 1900 Mr. G. F. C. Searle described an apparatus he had used to determine some elastic constants for wires of different metals. One very curious result which he obtained was that the value of Poisson's ratio found for certain metals was greater than $\frac{1}{2}$, notably in the case of copper whether hardened or annealed.

Mr. Searle's deduction was that "wires of these four substances (copper, nickel, platinoid, and german-silver) are so far from being isotropic, that it is improper to apply the theory of isotropic solids to them."

It was suggested to the author by Professor Ewing that it

* Communicated by the Author.

would be of interest to extend these experiments to wires of larger diameter; this suggestion was followed with results appended below.

In the author's experiments six different wires were used (one of which was hollow), of diameters varying from $\frac{1}{10}$ inch to $\frac{1}{4}$ inch. These diameters are greater than those measured by Mr. Searle (which were from $\frac{1}{25}$ inch to $\frac{1}{16}$ inch), thus necessitating a much larger apparatus—the moment of inertia of the vibrating rods being over six times as great.

It is not necessary to repeat the mathematical theory given by Mr. Searle, but the apparatus is shown in fig. 1.

Fig. 1.

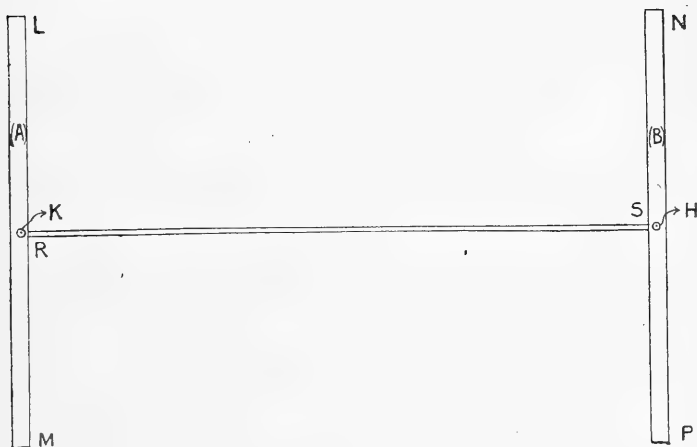

NP and LM are square bars with holes drilled at R and S to admit the wire under test at RS. H and K are two $\frac{5}{16}$ -inch screws by means of which the vibrating wire is clamped and the apparatus supported.

The method of experiment is as follows:—The apparatus is suspended so that the two swinging bars are in a horizontal plane; the ends at M and P are next inclined to each other and tied with strong cotton-thread. When the apparatus has come to rest, this thread is burnt and the number of swings per second is estimated by timing a convenient number with a stop-watch. The period so obtained is called t_1 .

It is an important experimental point that, owing to non-uniformity of diameter in the wire under test, the two rods should be rotated relative to the wire through 90° , and a re-determination of t_1 made. In the following experiments

this plan was adopted and the results are given: very little variation was found.

The next step is to clamp one rod horizontally and allow the other to hang down below, the under one is then slightly rotated—so twisting the wire—and released. The period of this vibration is also found, and called t_2 .

Here again a re-determination is made by turning the apparatus upside down; this corrects variations in the moment of inertia of the rods.

The constants of the apparatus were carefully determined thus:—

<i>Bar A.</i>	<i>Bar B.</i>
Weight = 2.932 lb.	= 2.936 lb.
Length = 18.50 inches.	= 18.50 inches.
Breadth = 0.756 inch.	= 0.755 inch.
(Mean of four measurements.)	
Depth = 0.763 inch.	= 0.763 inch.
(Mean of four measurements.)	
Moment of Inertia } = K = 0.2167	= .2170

Mean value of K = 0.2169.

The formulæ given by Mr. Searle are:—

$$E = \frac{8\pi Kl}{t_1^2 a^4} (1 + \alpha); \quad N = \frac{8\pi Kl}{t_2^2 a^4};$$

$$\frac{E}{N} = \frac{t_2^2}{t_1^2} (1 + \alpha) \quad \text{and} \quad \sigma = \frac{E}{2N} - 1.$$

Where $\alpha = \frac{ml^2}{60K}$ = correction for mass of wire,

E = Young's modulus,
 N = modulus of rigidity,
 K = moment of inertia of bars,
 l = length of wire,
 a = radius of wire,
 σ = Poisson's ratio,
 m = mass of wire.

Fig. 2 shows the method of suspension in the first part of the experiment.

CD is a part elevation of one rod suspended from a cord at H. E is the $\frac{5}{16}$ -inch screw which screws into a hole in the top of the rod and grips the wire at G. The under part of

the wire is placed on the top of the screw F and adjusted to the centre of the hole. The surface of the lower screw where it grips the wire is filed to a V-notch; this increases the hold and allows of alignment.

Fig. 2.

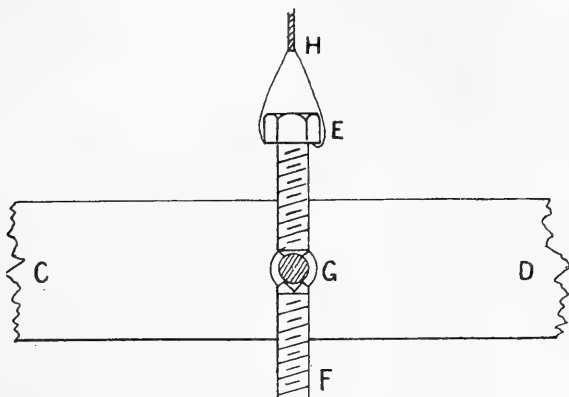

In all cases a considerable number of swing-swangs were recorded, the number varying from 70 to 700 according to the period, and the mean taken.

For convenience, the four periods determined will be referred to as the two horizontal periods and the two vertical periods.

The following table contains the results obtained for each wire, the diameter given in every case is the mean of 10 measurements; the length is measured between the centres of the grips.

It will be noticed that in no case was a value of Poisson's ratio found greater than 0.461; this, in view of the fact that Mr. Searle obtained several values above 0.5, is of interest as illustrating a possible effect of the increase in diameter of the wires used.

In conclusion the author wishes to thank Professor Ewing both for advice and the use of the different materials provided. The above experiments were carried out in the Engineering Laboratory at Cambridge.

HP I means horizontal period in first position. HP II means horizontal period when wire is turned through 90°. VPA means vertical period when rod A is vibrating. VPB means vertical period when rod B is vibrating. Rods A and B are shown in fig. 1. Units for E and N are one million pounds per square inch.

Date.	Material.	Diam. ins.	Length, ins.	Weight, lb.	HP I, secs.	HP II, ec s.	VPA, secs.	VPB, secs.	t_1' , secs.	t_2' , secs.	(1 + α).	E.	N.	σ .	Temp. ° F.
19.5.00	Soft brass.	0.1042	28.2	0.075	1.151	1.169	1.953	1.946	1.160	1.950	1.0118	15.69	5.489	0.429	54
21.5.00	Harder brass.	0.1652	28.45	0.185	0.465	0.466	0.785	0.784	0.4655	0.7845	1.0298	15.82	5.488	0.461	60
21.5.00	Soft copper.	0.1342	29.3	0.132	0.686	0.690	1.098	1.097	0.688	1.0975	1.0226	17.02	6.540	0.301	60
22.5.00	Copper tube.	$\left. \begin{array}{l} 0.2564 \\ \text{outside} \\ 0.175 \\ \text{inside} \end{array} \right\}$	$\left. \begin{array}{l} 29.5 \\ 27.7 \end{array} \right\}$	0.270	0.219	0.216	0.341	0.338	0.2175	0.3395	1.0466	16.50	6.463	0.274	—
23.5.00	Iron wire.	0.1040	27.7	0.064	0.854	0.853	1.354	1.353	0.8535	1.3535	1.0097	28.61	11.27	0.270	59
24.5.00	Iron wire.	0.1581	27.3	0.151	0.359	0.368	0.566	0.566	0.3635	0.566	1.0223	29.56	11.92	0.239	58

XLII. *A Comparison of Platinum Thermometers of different degrees of Purity.* By H. M. TORY, M.A., *Mathematical Lecturer at McGill College, Montreal**.

1. **T**HIS investigation was undertaken at the suggestion of Professor Callendar with a view to determining the probable order of accuracy in the determination of high temperatures attainable by the use of ordinary commercial specimens of platinum wire. It was also desired to observe the effect of large variations in the purity of the wire, in order to be able to estimate the probable effect of such small impurities as were likely to occur in pure wires specially selected for pyrometry. Five wires in all were compared over the range 400° to 1000° C. The fundamental coefficients of the wires (which may be taken as an indication of the purity) varied from $\cdot 003892$ to $\cdot 002340$, *i. e.* by 40 per cent. of the maximum value. It was found, however, that the extreme variations of the temperatures observed, when calculated on the platinum scale by the formula

$$pt = 100(R - R^{\circ}) / (R' - R^{\circ}), \quad (1)$$

in which the letters R , R' , and R° stand for the observed resistance at the temperatures pt , 100° , and 0° C. respectively, did not in any case exceed 9° C. at 1000° C., or were less than one per cent. on the interval at any point of the range of observation, in spite of the large differences in the samples.

When the temperatures were reduced by means of the difference-formula

$$t - pt = dt(t - 100) / 10,000, \quad (2)$$

although the agreement was found to be exceedingly close at temperatures up to 500° C. (if the value of the difference-coefficient d was calculated by assuming the boiling-point of sulphur (S.B.P.) to be $444^{\circ} \cdot 53$ C., by the method proposed by Callendar and Griffiths), the discrepancies at 1000° were still of the order of 5° or 10° C. We must conclude that this method of reduction by reference to the S.B.P. will not give results of the highest accuracy if applied to impure wires at 1000° C. This point has also been illustrated by Callendar (*Phil. Mag.* Feb. 1899). It was found, however, that very fair agreement could be obtained at high temperatures by using the freezing-point of silver (AgF.P.) as a secondary fixed point instead of the S.B.P. in the calculation of the difference-coefficient. For two of the wires the simple method of reduction employed by Heycock and Neville (*Journ. Chem. Soc.* Feb. 1895, and

* Communicated by the Physical Society: read June 22, 1900.

Phil. Mag. Feb. 1899, p. 200) gave results agreeing with the standard wire almost within the limits of error of observation, but did not apply so well in the case of the most impure specimens. It was observed, however, that the differences of the platinum temperatures for all the wires could be very closely represented between the limits of observation by linear formulæ. If the observed values of pt for each wire were first reduced to the standard pt in each case by the linear relation, and then corrected by the same difference-formula as the standard wire, very consistent results were obtained from all the wires. This method would not be applicable below 400°C ., but it might prove a suitable type of formula for purposes of extrapolation, in case it was necessary to employ impure wires.

It is probable that the platinum wires used in this investigation were free from contamination with baser metals outside the platinum group. Under proper conditions they all showed great constancy of zero, and the variation of the difference-coefficients (from 1.50 to 1.67) was comparatively small. By contamination with baser or more volatile metals, it is possible to get much larger variations in the values of pt and d ; but such pyrometers will not show constant results until the volatile constituents have been burnt out. Special attention was given to the effects of annealing which may produce changes of zero of the order of one degree after the first exposure to a temperature of 1000°C . With this exception, no changes of zero of any importance were observed, as the temperatures employed never exceeded 1000°C .

2. *Methods and Apparatus.*—The method of comparison adopted was that described by Callendar (Phil. Trans. A, 1887, p. 161), in which the wires to be compared are wound side by side in the same tube, so as to be always at the same mean temperature. This method appears to be more accurate than the method of indirect comparison of pyrometers in separate tubes. Observations were taken at steady temperatures only, in a well-stirred bath of melted tin. The apparatus was arranged so that the readings of the two pyrometers were almost simultaneous. Each wire was directly compared with the pure standard wire; and in addition a specimen of the standard was drawn down to half section, and compared with the original wire. The agreement was found to be exact throughout the scale, as was to be expected with so pure a wire. The wires were wound on mica strips with platinum leads insulated in the usual manner. Each double pyrometer, when completed, had six leads, two each for the pyrometer coils, and two compensating leads. The resistance-box used

was one of the type described by Callendar (Phil. Mag. July 1891) with coils on the binary scale, standardized in the usual manner. The contact surfaces of the screw-nuts used for short-circuiting the coils were kept clean, and the contacts frequently tested. The galvanometer used was one specially designed by Prof. Callendar (Phil. Mag. Feb. 1892) for resistance pyrometer work, with an astatic-needle system in which the control is due to the passage of a current through a pair of coils, marked "Field" in fig. 1, at right angles to the position of the galvanometer-coils. The current which effects the control is proportional to that used in measuring the resistance, and hence the deflexion due to any given difference of resistance is constant, no matter what the current may be. It was found, for example, that the deflexion for a difference of resistance of one unit of the bridge, was exactly the same whether a two-volt or four-volt battery was used.

Fig. 1.

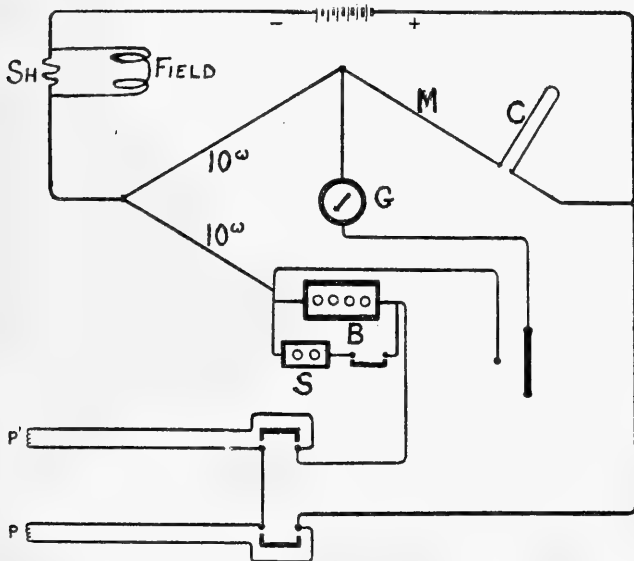

In order to secure a proper sensitiveness of the needle, the field or control coils were shunted with a small resistance marked Sh, which was adjusted so that a change of resistance of one bridge-unit produced a deflexion equal to 10 divisions of the galvanometer-scale. By this means, the deflexions could be read to 1/100 of a degree, which was sufficient for the purpose.

3. *Resistance Measurements.*—The ratio-coils of the bridge were connected permanently in the galvanometer-case, and had a fixed resistance of about 10 ohms each, being made exactly equal. The standard or balancing coil M, against which the resistances of the pyrometer and box were balanced, was also fixed permanently in connexion with the galvanometer, but in such a way that it could be kept in a test-tube of oil, and its temperature taken after each observation. The compensating leads C were in series with this coil. The adjustable resistance-box B was inserted in the same arm as the pyrometer, and readings were taken by the method of substitution, so as to keep the resistance in circuit constant.

Before the pyrometer was put in the circuit, the balancing-coil M was adjusted exactly equal to the total resistance of the box B at 20°C ., so that when the pyrometer was inserted in the same arm as the box its resistance could be at once determined by reading the resistances of the box that were short-circuited, and taking the deflexion of the galvanometer. In addition to the usual coils in the box, namely, 640, 320, 160, 80, 40, 20, 10 units, two others were added, of 5 and 2 units respectively; so that deflexions of the galvanometer greater than 20 scale-divisions were never required to be taken. Ordinarily it is not necessary to adjust the balancing-coil M equal to the resistance of the box, as only the differences $R - R^{\circ}$ and $R' - R^{\circ}$ are required. It was convenient, however, in order to get the temperature-coefficient of the wire used. The temperature-coefficient of the platinum-silver box coils was determined to be $\cdot 000330$ per degree, and that of the manganin balancing-coil M to be $\cdot 000045$. All the observations were corrected for both box and coil.

The resistances of the pyrometers used for comparison, owing to the large differences in the temperature-coefficients of the wires, differed considerably, excepting at the points where they were calculated to agree. The fundamental interval, $R' - R^{\circ}$, was usually calculated for one pyrometer to be 100 approximately, and the other to have a nearly equal resistance at 500° , the temperature-coefficients being roughly determined before the pyrometers were made up. The result of this difference of resistance was, that it was found exceedingly difficult to take readings of the pyrometers in the usual way so quickly as to be sure that the temperature was constant to $1/10$ of a degree during the process. The pyrometers were first connected in series, so that one could be immediately short-circuited and the other read after adjusting the resistance in the box. The time required to take a reading in this way, on account of the swing of the needle of the galvanometer, was about three minutes.

4. *Shunt method of Comparison.*—In order to get over this difficulty and secure simultaneous readings, the following method was adopted. The two pyrometers P and P₁ were connected in series with the resistance-box B, through a mercury-cup switch, so that by rocking the top of the switch they could be short-circuited one after the other, by means of thick copper wires attached to the rocker. Connected with the same switch there was an arrangement such that when P₁ was short-circuited and P was to be measured, the box B was shunted by means of a mercury connexion. The shunt-box S was then adjusted so that the deflexion of the galvanometer for P₁ with B unshunted was exactly the same as that of P with the shunt S in parallel with B. The shunt S was a standard resistance-box in ohms with an attachment for reading to tenths. As the shunt S was usually large compared with B, it was not necessary to know S nearer than 1/10 of an ohm, while the change of resistance, due to the change of temperature of the box, was negligible. Further, an arrangement was made on the same switch for opening and closing the galvanometer circuit, so that the galvanometer was opened first and closed last on rocking the switch. The result was, since, as before stated, the units of the box were so arranged that a deflexion of 20 scale-divisions was the largest necessary, that with a little practice the switch could be rocked and the deflexions of the two pyrometers read almost simultaneously, the needle of the galvanometer not swinging more than a couple of scale-divisions. The readings could be easily taken within five seconds of each other, and verified again and again without the slightest difficulty, as the temperature slowly changed. The use of the shunt, while it diminished the difficulty of taking observations, somewhat increased the labour of calculation. If (P₂ - P₁) be the difference of resistance of the two pyrometers for any temperature, and B the resistance in the box which with the pyrometer P₁ balances the standard coil M, and if S be the shunt to B for the second pyrometer P₂, then

$$M = P_1 + B = P_2 + BS / (B + S),$$

whence

$$P_2 - P_1 = B^2 / (B + S), \quad (3)$$

assuming the deflexions of the two pyrometers to be the same. The factor for reducing the units of the shunt-box (ohms) to units of the pyrometer-box was determined from equation (3) by observations taken at 0°, 100°, and 444.5 (the boiling-point of sulphur) first with the two pyrometers separately using the box B only, and then simultaneously, using the shunt with the second pyrometer.

5. *Method of Heating.*—In order to get an accurate comparison, only steady temperatures were used. For this purpose, the pyrometers, enclosed in a porcelain tube, were heated in an iron pot of molten tin, and the gas-supply regulated by means of a constant-pressure gas-regulator. The gas also flowed through a graduated gas-supply regulator, so that, with a little patience, almost any temperature between 400° and 1000° C. could be obtained. The furnace used was one whose maximum was 1000° , so that the observations were not taken beyond that point. The molten tin was continuously stirred by means of an air-engine and stirrer. It was found necessary to make the stirrer of fire-clay or tool-steel. When iron was used, the action of the tin at its surface, on the iron, soon rendered it useless. To prevent oxidation of the tin, which took place very rapidly when the surface was exposed, and as a result soon filled the pot with tin oxide in a semi-viscous condition, various expedients were used. The one which succeeded best was to keep the surface covered with a stratum, half a centimetre thick, of ground arc-light carbon.

The greatest difficulty experienced was due to the action of the tin on the porcelain tubes. They would not stand repeated heatings in the tin bath, but became very rotten. Several of the observations were spoiled by the tubes breaking at the moment of removing them from the molten tin. It was sometimes difficult at first to remove the pyrometer-tubes, because of the oxidized tin on the surface. After the difficulty of oxidation was overcome, less trouble was experienced, but the tubes were never used more than two or three times without becoming so affected at the junction with the surface of the tin, as to make it undesirable to use them again. In taking the melting-point of silver, the tubes which had been previously used for only one set of observations in tin, generally broke when removing them from the melted silver, though the greatest care was exercised.

6. *Results of Observations.*—Four different samples of ordinary platinum wire were compared with a very pure specimen in general use in the laboratory as a standard, between 400° C. and 1000° C., the two extremes of the furnace used. The temperature-coefficient of the standard wire was found to be slightly different in different pyrometers. These variations were due doubtless to the lack of absolute uniformity in the wire, but were not sufficiently large to affect the readings of temperatures at 1000° by more than $1/10$ of a degree. The difference-coefficient d of each wire in the formula (2) was calculated from an observation of the boiling-point of sulphur in the usual way.

The accompanying curves (fig. 2) show graphically the relations between the various wires, plotted with the platinum temperatures of the standard wire as abscissæ and for ordi-

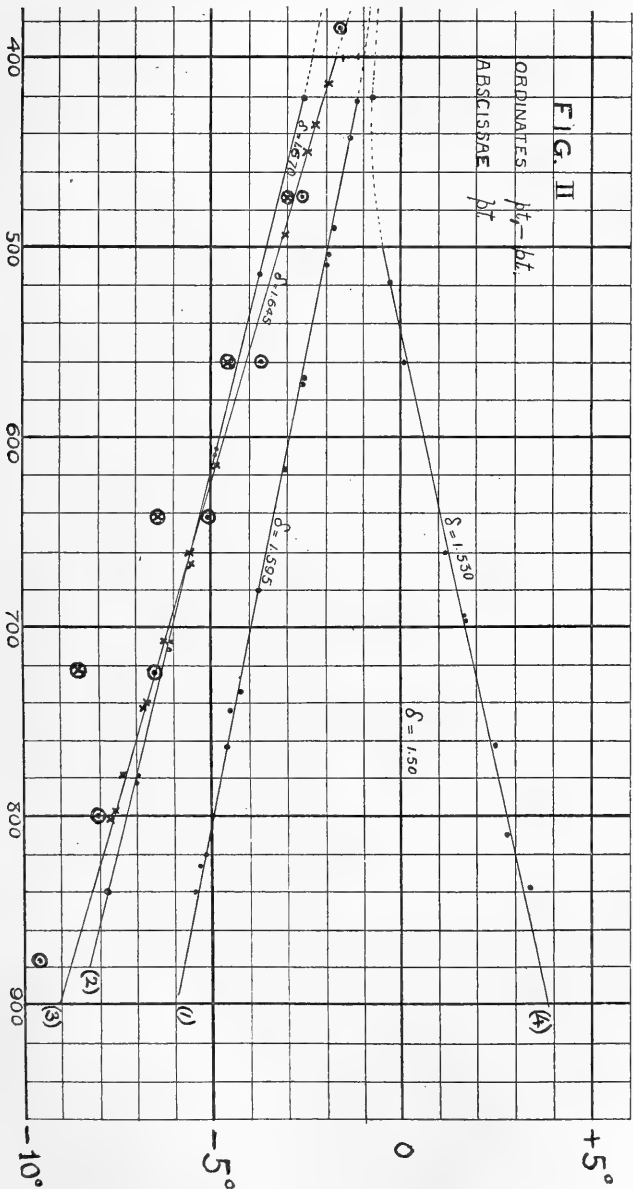

Fig. 2.—Differences of Platinum Thermometers from Standard, referred to pt as abscissa. \odot Points calculated by Difference Formula for $d = 1.650$. \odot Dito by Heycock and Neville's Method. \otimes Points calculated by

nates, the differences $Pt' - Pt^\circ$, the difference-curve belonging to each wire being denoted by the value of its d . It will be seen that *the difference-curves are all nearly straight*, between the limits of observation. It follows that a linear relation, involving only two unknown quantities, will express the relation of any one of them to the standard, thus:—

$$pt - pt' = a pt + b,$$

which may be written, if a is small,

$$pt = pt' + a pt' + b. \quad (4)$$

By observing therefore the differences between the platinum temperatures of the wires for two points, such as the S.B.P. and the Ag F.P., the constants in formula (4) can be found for each wire.

TABLE I.

Values of Constants a and b in the Linear Formula (4), for each of the Impure Wires as compared with the Standard.

No. of Wire.	Difference-Coefficient.	Fundamental Coefficient.	Coefficient a .	Coefficient b .
1	1.595	.003164	+0.103	-3.14
2	1.670	.002689	+0.124	-2.65
3	1.645	.003216	+0.142	-3.80
4	1.530	.002340	-0.106	+5.73

Since the differences are so small between the different wires, the platinum temperatures observed with each wire can be easily reduced to the scale of the standard wire by the linear formula (4), and then corrected by the standard difference-curve to the scale of the gas-thermometer. The results thus obtained would agree within the limits of the present series of observations with the Standard Scale recently proposed by Callendar (Phil. Mag. Dec. 1899), which is based on the application of the difference-formula (2) to the pure standard wire. In this paper, it is pointed out that in all probability the value there given for the melting-point of silver, viz. 960°C ., is correct to within 1° or 2° , and it is suggested that a standard platinum wire be adopted, any other wire being referred to it by determining the melting-point of silver or gold, and the boiling-point of sulphur. To the evidence there adduced might be added the redetermination of the melting-points of gold and silver, by

M. Berthelot, who gives the two points as 962° C. and 1064° C. It seems to be a reasonable conclusion, therefore, that from 0° up to the melting-point of gold, 1060° , at least, a practical thermometric scale could be established, which would at no point differ from the gas-thermometer scale by more than 2° or 3° . It would follow that all observers working with platinum pyrometers could, in a most certain and ready manner, compare their results. The standard sample would thus be defined as a wire with a definite sulphur boiling-point, and a definite silver melting-point. In fact a number of definite points could be defined up the scale, any two of which could be used.

I have not yet carefully studied the difference below 400° or above 1000° , but hope to do so in the near future. It would appear, however, from results obtained, that the linear difference-curve commences to bend below 400° , meeting the reference line at 100° C. Such a process of reduction is hardly necessary, however, below 500° C., as in any good specimen of platinum wire the temperatures can be reduced directly by the difference-formula, using the value of d determined from the S.B.P.

7. *Variation of Temperature-Coefficients.*—Since the differences between the platinum temperatures of two wires depend on the rate of change of the temperature-coefficients of the wires, the following table may not be uninteresting:—

TABLE II.

Values of Temperature-Coefficients over Different Ranges.

No. of Wire.	Difference Coefficient.		Fundamental Coefficient, c .	Coefficient $0^{\circ}-445^{\circ}$.	Per-cent. of c .	Coeffi-cient $0^{\circ}-960^{\circ}$.	Per-cent. of c .
	S.B.P.	AgF.P.					
1	1.595	1.561	.003164	.002991	94.6	.002739	86.6
2	1.670	1.592	.002689	.002533	94.7	.002322	86.4
3	1.645	1.600	.003216	.003033	94.3	.002775	86.3
4	1.530	1.461	.002340	.002215	94.6	.002047	87.4
Standard	1.500	1.500	.003892	.003692	94.8	.003391	87.0

It will be observed that the percentage diminution of the coefficient of each of the wires is nearly the same over the range 0° to 960° in terms of the fundamental coefficient.

It follows that the values of the difference-coefficients obtained by reference to the AgF.P. are nearly the same, and afford a convenient method of reduction at temperatures near 1000° C. The S.B.P. difference-coefficients do not give very good agreement at 1000° C. for impure wires.

8. *Method of Heycock and Neville.*—In the simple and convenient method of reduction employed by Heycock and Neville, the difference-coefficients for the various pyrometers are calculated as usual from the S.B.P., but the reduction of the observations from pt to t is effected by means of a single difference-curve, drawn for the standard wire only, in terms of pt as abscissa. The platinum temperature pt observed with any pyrometer is reduced to the normal scale by taking from the standard curve the difference $t-pt$ corresponding to the observed value of pt , and increasing it in the ratio d/a° of the appropriate difference-coefficient d to the standard d° . This method does not give absolute agreement with the difference-formula (2) unless $d=d^{\circ}$, but it often appears to give more consistent results than (2) in the case of impure wires at 1000° C., and it is simpler to apply, as it requires only one difference-curve, which is drawn for the standard wire.

The following tables will show how close this agreement is for three of the wires tested. The first column shows, for each case, the temperatures for the standard wire corrected by the difference-formula; the second, headed Test, shows the corresponding values for the impure wire, corrected by Heycock and Neville's method.

TABLE III.
Reduction by Heycock and Neville's Method.

Standard.	Test No. (1).	Standard.	Test No. (2).	Standard.	Test No. (3).
948.58	948.66	965.9	968.9	932.5	932.9
937.90	938.16	882.8	884.9	939.6	939.8
864.55	864.55	882.3	884.5	882.7	882.6
839.37	839.10	793.9	795.4	832.4	832.1
821.23	821.24	785.7	787.1	831.8	831.6
753.49	753.51	786.1	787.3	788.6	788.6
673.33	673.22	659.5	660.0	738.7	738.5
621.79	621.72	664.6	664.8	729.0	728.8
619.67	619.61	551.4	551.3	675.9	675.6
550.59	550.32	551.8	551.6	623.2	622.9
549.89	549.81	440.0	443.7	597.5	597.3
522.75	522.88			525.9	525.6
469.78	469.86			479.9	479.7
				434.0	433.9

It will be seen that for the first and third wires the results are in agreement, almost within the limits of error of observation by direct comparison. In the second wire the agreement is not so complete, which is not at all remarkable when it is observed that the temperature-coefficient of this wire is 33 per cent. less than that of the standard. The fourth wire (the most impure) does not agree at all when reduced by this method*.

9. *Effect of Annealing.*—As before stated, considerable changes of zero were found in some of the wires on first heating them to 1000° for a couple of hours, in one instance a rise of no less than 2° . In this extreme case, there seems to be no reason to doubt that the mica used was largely the cause, as the wire after prolonged use became slightly discoloured. A specimen of the mica used was tested chemically and found to be slightly acid. The standard wire, which was chemically very pure, was also slightly affected in this pyrometer; and hence the observations were disregarded. Afterwards some white mica was obtained, from the Instrument Co., Cambridge, and when proper precautions were taken in winding and annealing, the standard wire never showed changes of zero greater than $0^{\circ}\cdot 2$ or of F.I. greater than $0^{\circ}\cdot 03$, after heating to 1000° C. Most of the impure wires used, however, showed changes somewhat greater than this. In the case of the wire $d=1670$, a fall of $1^{\circ}\cdot 2$ was observed in the zero on first annealing at 1000° for one hour. This was doubtless due to the fact that, in winding the coil, the wire, as bent on the frame, was in a state of unequal tension, and when heated to 1000° this was relieved, with a consequent fall of zero on cooling. For accurate work, too great care cannot be exercised in winding the pyrometer-coil. A fall of zero may be easily produced as above, or, if the wire be wound too tight originally, a thickening of the mica may cause a rise of zero, as suggested by Heycock and Neville. *After the coil is wound*, the pyrometer should be annealed for some time at a temperature beyond that for which it is to be used, and allowed to cool slowly

* *Footnote added by Prof. Callendar.*—In order to illustrate the nature of the agreement of the observations with the difference-formula and with Heycock and Neville's method, I have inserted in fig. 2 a series of points representing the values of the differences $pt' - pt$ for a wire $d=1650$ calculated by the two methods, \oplus by the difference-formula, \odot by Heycock and Neville's method. It will be observed that up to $600\ pt$ both methods agree about equally well with the observations. Above 600° the observed difference is much less than that calculated by the difference-formula. The second method agrees very fairly up to 800° , but tends to diverge from the linear formula beyond that point.

and equally, before the constants are determined. If the pyrometer is used frequently for high temperatures, it is occasionally necessary to redetermine the zero in the most accurate work to allow for minute progressive strains.

10. *Effect of Wire-drawing.*—In order to test the effect of the mechanical working of the wire on its thermometric scale, I had a piece of wire of diameter 6 mils drawn down to 4 mils, and a double pyrometer made from these two. The wire was softened by passing quickly through a bunsen-flame before winding, but not annealed after winding. On determining the constants, it was found that the platinum temperatures for the boiling-point of sulphur differed by $1^{\circ}.30$. The pyrometer was then heated to 1000° for an hour, and slowly cooled, and the constants again determined. The wires then agreed at the boiling-point of sulphur to $.01$ of a degree, and on taking the melting-point of silver a proportionately good agreement was obtained. The difference in the first case was certainly due to insufficient annealing. The pyrometer was tested again and again, and the results were always in complete agreement. These observations on samples of the same wire led to the conclusion that the constants determined *after* the high temperatures and not *before*, as suggested by Heycock and Neville, should be used in the calculations (provided that the wire is not strained in cooling), and this has been uniformly done, but the difference in any case is very slight.

The wires used differed greatly in specific resistance. In all cases, the wires with the smallest temperature-coefficients had the largest specific resistance, and, with the exception of No. 4, gave the lowest platinum temperatures. The wire $d=1.670$ had a specific resistance about 30 per cent. greater than that of the standard, and the others nearly as great, but the measurements of specific resistance could not be made very accurately on wires of so small a diameter.

In conclusion, I must thank Prof. Callendar for kind assistance, Miss Harriet Brooks, B.A., of the Royal Victoria College, and Mr. N. M. Yuile, M.Sc., of the Mining Department, McGill College, for assistance in taking observations.

McGill College, April 19th, 1900.

XLIIL. *Notes on Gas-Thermometry.* By P. CHAPPUIS, Ph.D.,
Savant Attaché au Bureau International des Poids et
Mesures, Sèvres, France.*

I. **I**N a recent research, the results of which have just appeared in the Philosophical Transactions of the Royal Society, Dr. J. A. Harker and the author endeavoured to compare the indications of the platinum resistance-thermometer and the normal scale over the range -20° to 600° †.

Having been led to recognize that hydrogen could not be employed as thermometric substance on account of its action on the walls of the glass reservoirs at high temperatures, we had recourse to a constant-volume nitrogen-thermometer having an initial pressure slightly under 800 millim., and assumed provisionally that the thermometric scale of this instrument represents the normal scale of temperature. It is of interest to ascertain whether this hypothesis is justified by the facts, or in other words to determine the divergence of the constant-volume gas-thermometer from the normal scale at high temperatures.

Corrections to the Nitrogen Thermometer.

Measurements previously made with a constant-volume nitrogen-thermometer ‡ having an initial pressure of one metre have shown that the coefficient $\frac{1}{P} \frac{dP}{dt}$ varies to an appreciable extent, so that under these conditions the divergence between the nitrogen thermometer and the normal scale attains 0.01 at its maximum near 40° .

The expression for the dilatation of nitrogen at the temperature t° deduced from the observations made with this thermometer is

$$0.003\ 676\ 98 - 7.826\ 746 \times 10^{-8}t + 4.780\ 076 \times 10^{-10}t^2.$$

* Communicated by the Physical Society: read June 22, 1900.
 Translated from the Author's MS. by J. A. Harker.

† The temperature scale adopted as the standard by the International Committee of Weights and Measures is defined as the Centigrade Scale of the Hydrogen Thermometer, having as fixed points the temperature of melting ice (0°), and that of the vapour of distilled water in ebullition (100°) under the normal atmospheric pressure; the hydrogen being taken under the manometric initial pressure of one metre of mercury, *i. e.* at 1000

$\frac{760}{760} = 1.3158$ of the atmospheric pressure.

‡ Chappuis, *Travaux et Mém. du Bureau International*, vol. vi. 1888.

The values deduced from this function for a few points are

Temp.	Coeff.
0°	0·00367 698
20	560
40	461
50	427
60	400
70	384
80	378
90	381
100	0·00367 393

From this expression it appears that the coefficient of dilatation of nitrogen diminishes gradually up to about 80°, then increases very slightly. This increase, which is of the same order of magnitude as the probable errors, is not in agreement with our knowledge of the variations of the coefficients of gases. It is very probable that the coefficient approaches a definite limiting value for each initial pressure, which in this case seems to be attained below 100°. In fact, nitrogen at 100° behaves like hydrogen at the ordinary temperature, its compressibility being less than is required by the Boyle-Mariotte law. It may be seen from the table just given that this limiting value of the coefficient is approximately

$$\alpha_2 = 0\cdot00367\ 380.$$

Assuming this value, it is possible to calculate the fictitious initial pressure which should have been observed if the nitrogen had retained down to 0° the properties of a perfect gas.

We thus obtain the following relations:

$$P_t = P_0(1 + \alpha t); \quad \text{whence } P_0 = \frac{P_t}{1 + \alpha t}.$$

But from direct observation we have

$$P_0 = 1, \quad \text{and } P_{100} = 1\cdot367466,$$

whence we obtain for the mean coefficient of dilatation α_1 between 0° and 100°

$$\alpha_1 = 0\cdot003674\ 66.$$

The fictitious initial pressure of the nitrogen thermometer supposed perfect may be deduced from the expression above:

$$P_0 = \frac{P_{100}}{1 + 0\cdot00367380 \times 100} = 1\cdot000063.$$

From these data it is a simple matter to calculate the divergences of the nitrogen thermometer from the normal scale within the interval covered by our comparisons.

Temperature.	Differences of Scale.
	Actual Scale—Normal Scale. $P_0=1$ metre.
100°	0·000
150	—0·008
200	—0·017
250	—0·026
300	—0·034
350	—0·043
400	—0·051
450	—0·060
500	—0·068

From this it would appear that the pressures indicated by a constant-volume gas-thermometer are a little too low, but the errors are small and appear to be of less account than other sources of uncertainty which enter into the measurements. Besides I would remark that in our comparisons of the platinum-thermometer with the nitrogen-thermometer, the initial pressure was always less than one metre. (In the comparisons between 100° and 200° it was 793 millim, and in those between 250° and 500° it was always less than 550 millim.) Under these conditions the systematic divergences of the nitrogen scale from the normal are probably diminished in the same proportion as the initial pressures. They will then be less than 0°·04 for measurements at temperatures near the boiling-point of sulphur.

II. *Determination of the Sulphur-Point.*

The mean result of our experiments for the determination of this important point is

$$T_s = 445^{\circ}\cdot 2$$

under the barometric pressure of 760 millim. Messrs. Callendar and Griffiths, employing the constant-pressure air-thermometer, have found for the same point

$$T_s = 444^{\circ}\cdot 53.$$

The difference between these two results—0·7— is, I believe, to be attributed to the joint action of several causes:—

(1) The scale of the constant-pressure nitrogen-thermometer diverges more widely from the normal temperature-scale than

that of the constant-volume thermometer. From experiments made at the Bureau International in 1888*, it would appear that the divergences of the former are about double the latter. Reduction to the normal scale would raise the result of Messrs. Callendar and Griffiths at least a tenth of a degree.

(2) The coefficient of expansion of air at constant pressure, determined by Messrs. Callendar and Griffiths and used by them in the determination of their temperatures, is

$$\alpha = 0.003\ 6749.$$

This coefficient is very sensibly greater than that obtained for air under similar conditions of pressure by Regnault, who found

$$\alpha = 0.003\ 6700 ;$$

or the result given by my own more recent experiments,

$$\alpha = 0.003\ 6708.$$

If in the calculation of Callendar and Griffiths's experiments they had taken the latter value,

$$\alpha = 0.003\ 6708,$$

their value for the boiling-point of sulphur would become $445^{\circ}.0$ instead of $444^{\circ}.3$.

(3) A possible cause of part of the divergence may also be sought in one of the elements entering into one of the corrections involved in the determination of temperatures with the gas-thermometer, namely, the dilatation of the material of the reservoir, discussed at some length by Prof. Callendar in a recent article in this magazine, vol. *xlvi*. p. 542.

It is customary to express this dilatation by a function of the form

$$v_t = v_0(1 + \alpha t + \beta t^2),$$

in which α and β are constants.

The determination of the constant α is of no great importance in the measurement of temperatures by the gas-thermometer.

The value of α only affects the value obtained for the coefficient of the dilatation of the gas. It is, however, otherwise with the coefficient β , the influence of which increases with increase of temperature. (See in this connexion, Callendar, *loc. cit.* p. 544.)

Of the methods actually employed for the determination of coefficients of expansion, the most precise is undoubtedly

* *Procès-verbaux des séances de 1888*, p. 98 *et seq.*

that of Fizeau. But up to the present no experiments have been made by this method above 100° .

It follows that coefficients deduced from experiments made with this apparatus are only rigorously applicable over the range 0° – 100° *; and it may justly be objected that extrapolation to 450° might introduce into the results quite sensible errors. The dilatation of Berlin porcelain, which is the material out of which the reservoirs employed for the higher temperature work were made, was determined by me over the interval 0° – 100° . I found for the cubical dilatation

$$v_t = v_0(1 + 8.0703 \times 10^{-6}t + 8.98 \times 10^{-9}t^2).$$

The importance of the second term is easily seen. It is sufficient to note here that if, instead of this expression, we take

$$v_t = v_0(1 + 8.96835 \times 10^{-6}t)$$

(which is the mean coefficient between 0° and 100°), we should have for the sulphur boiling-point

$$T_s = 444.3$$

instead of the value 445.2 , which results from our calculation.

Mr. Bedford has recently published in this Journal † the results of a determination of the dilatation of a tube of Bayeux porcelain, obtained by a method previously employed by Callendar and Griffiths.

The porcelain tube, which served for Mr. Bedford's measurements, had external and internal diameters of 17 mm. and 10 mm. respectively. Near the ends were two marks, 91.4 cm. apart, made by a diamond. The variations in the distance apart of these two marks were measured by a comparator provided with two microscopes under which could be brought successively the porcelain tube and a glass tube maintained at constant temperature.

The porcelain tube could be heated to any temperature between 0° and 840° , which was measured by the change of

* The fundamental study of the dilatation of the three screws of the platinum-iridium tripod, which constitute the standard to which all measurements with this apparatus are referred, was made with great care by M. Benoit, the Director of the Bureau International, and is described in full in the *Trav. et Mém.* t. vi., 1888. This laborious piece of work, which is attended with peculiar difficulties, would have to be extended to higher temperatures, if it were desired to extend upwards the range over which the Fizeau apparatus can be employed.

† *Phil. Mag.* vol. xlix. p. 490.

resistance of a platinum wire traversing the whole length of the tube and furnished with Callendar's compensating leads.

The observations, which are given in detail in the paper, led Mr. Bedford to the following expression for the cubical dilatation of Bayeux porcelain:—

$$v_t = v_0(1 + 10275t + 3 \cdot 24t^2)10^{-9}.$$

Treating the same observations by least squares, I found the slightly different result

$$v_t = v_0(1 + 9715 \cdot 6t + 4 \cdot 43t^2)10^{-9}.$$

Or, if the temperatures thus found on Callendar's scale are reduced to the new scale on which our experiments are calculated:—

$$v_t = v_0(1 + 9781 \cdot 4t + 4 \cdot 276t^2)10^{-9}.$$

The incontestable advantage of the method employed by Mr. Bedford is that it allows the determination of the dilatation over the same temperature range as the thermometer reservoir is subsequently to be employed; but nevertheless the fact cannot be ignored that to obtain very exact results by a process of this kind must be a matter of extreme difficulty.

I would first remark that the marks made on the tube are more than 8 millim. distant from the neutral plane; and under these conditions the mode of support of the tube must necessarily exercise a considerable influence on the results obtained. And, further, apart altogether from the inevitable variations in the distance between the supports, produced by the expansion of the medium in which they rest, we have the possibility of sensible variations in the elastic constants of porcelain, as yet undetermined at high temperatures.

From the author's indications it would seem that during the experiments the porcelain tube suffered a perceptible change of form. Further, the homogeneity of tubes of this kind is often somewhat doubtful, particularly when, like Mr. Bedford's, they are glazed. I have the advantage of possessing a specimen of Mr. Bedford's tube, obtained by the kindness of Prof. Callendar. The hole through it is considerably eccentric, so that opposite parts of the wall present variations in thickness of from 2 to 4 millim. The glaze having a coefficient of expansion probably differing slightly from that of the mass, it seems quite possible that the tube

might become slightly deformed on heating. In that case, once the scratches on it are not strictly in the plane of the neutral fibres, every variation in the curvature of the tube involves a change in the distance apart of the marks.

Under these conditions it would appear to me that Mr. Bedford's results, in spite of their real value, should not be accepted without reserve; and consequently I cannot wholly accept the conclusions of Prof. Callendar, who, after having compared the coefficients determined by me between 0° and 100° for "verre dur" and porcelain with those obtained by the method just described, is of opinion that my values of β are too large.

Bayeux porcelain having probably a composition differing slightly from that of Berlin, I thought it worth while to make a determination in the Fizeau apparatus on the specimen of Mr. Bedford's tube, which I had obtained. The specimen as prepared had a length of about 15 mm. The upper and lower plane surfaces were polished, and were very nearly perpendicular to the axis of the tube. The accompanying figure represents the aspect of the fringes* of

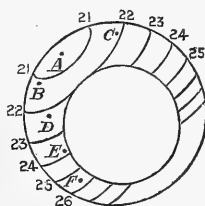

sodium light on this specimen in the first experiment made at $83^{\circ}.3$. At each steady temperature an estimate was made of the positions of each of the points A, B, C, D, E, F marked on the lens with reference to the fringes, which were numbered from the centre of the system outwards.

The irregularity of section of the tube and the defects in the surface as ground and polished, have rendered it impossible to operate on a larger number of points of reference.

The set comprising 33 separate observations, spaced out over the interval 1° to 83° gave for the linear dilatation of porcelain

$$l_t = l_0(1 + (2824.1t + 6.17t^2)10^{-9}),$$

* In the memoirs of M. Benoit on the Fizeau apparatus published in *Trav. et Mém.* tom. i. & vi., will be found all details regarding the measurement of dilatations by this ingenious method.

and for the cubic dilatation,

$$V_t = V_0(1 + (8472.4t + 18.53t^2)10^{-9}).$$

On comparing this result with that obtained by Mr. Bedford, it will be seen that the coefficient of the term in t^2 is here about four times as great. It is also about twice as great as that obtained formerly for Berlin porcelain (8.98×10^{-9}).

If we recalculate the last experiments made by the Fizeau apparatus, assuming the values of the coefficients as found by Mr. Bedford, we obtain the following numbers, alongside of which I have placed the values deduced from my observations:—

T.	Calculated from Bedford's Experiments. Fringes.	Observed.	Obs.—Calc.
20°.....	5.07	5.42	+0.35
40°.....	10.56	11.07	+0.51
60°.....	16.07	16.53	+0.46
80°.....	21.58	21.82	+0.24

The divergences Obs. — Calc. are so large as to be quite inexplicable by errors of observation, since in my experiments the largest residual errors are very rarely as much as a tenth of a fringe. It would appear, then, that there is an incompatibility between the two results, at least over the range of temperature covered by both. But the measurements on the Fizeau apparatus have revealed a fact, which I have mentioned already and which, I think, is likely to be the principal cause of the difference between us. On summarizing in tabular form the displacements of the fringes, as measured with regard to the different points of reference, it is evident at once that the thick part of the tube expands less than the thinner part.

If the dilatation of the tube were uniform over its whole cross-section, the differences between the readings obtained for the different points should be the same at all temperatures. But if, in this case, we take for two widely differing temperatures the differences from the mean for the six points

mentioned, we find values which are by no means identical. The following example relates to the two series of observations at 82° and 3° respectively :—

Difference of the individual estimations from the means M_1 and M_2 .

Group at 82° .		Group at 3° .		Difference.
	$\frac{\lambda}{2}$.		$\frac{\lambda}{2}$.	$\frac{\lambda}{2}$.
A- M_1	-1.89	A- M_2	-1.72	-0.27
B- M_1	-1.53	B- M_2	-1.47	-0.06
C- M_1	-0.61	C- M_2	-0.52	-0.09
D- M_1	-0.35	D- M_2	-0.39	+0.04
E- M_1	+1.30	E- M_2	+1.20	+0.10
F- M_1	+3.10	F- M_2	+2.92	+0.18
	$M_1=22.62$		$M_2=0.59$	

The observations made at intermediate temperatures confirm the rotation of the fringes indicated by the two series just quoted; and since, in the course of the observations, the direction of the temperature-change was varied frequently, the fact just mentioned seems well established.

The inequality in the dilatation of the two opposite sides of the tube necessarily involves a change in its form. The tube curves on expansion, which is probably the cause of the divergence found between Mr. Bedford's results and mine.

The conclusions of the study made by Dr. Harker and myself of the thermometric scale of the platinum-resistance thermometer and the sulphur-point do not appear to me to be invalidated by the results collected by Prof. Callendar, and I think we are justified in adhering to them, whilst recognizing at the same time the uncertainty which attaches to an application of the coefficient of expansion of the reservoir over an interval about four times as great as that in which it was determined, and where alone it is strictly applicable.

Consequences of a Change in the Sulphur-Point.

The modifications resulting in the adoption of our new value for the boiling-point of sulphur—namely $T_s=445^{\circ}.2$, instead of the value $444^{\circ}.53$, as obtained by Callendar and Griffiths, are shown in the following table.

Corrections applicable to Temperature measured by the Platinum Thermometer, assuming

$$T_s = 444^{\circ}\cdot 53, \text{ the value of } \delta \text{ being } 1\cdot 500,$$

to transform them to the new scale, where

$$T_s = 445^{\circ}\cdot 2, \text{ and } \delta \text{ would become } 1\cdot 538.$$

	0°.	10°.	20°.	30°.	40°.	50°.	60°.	70°.	80°.	90°.
-0	0·000	+0·004	+0·009	+0·015	+0·022	+0·029	-0·009	-0·008	-0·006	-0·003
+0	0·000	-0·004	-0·006	-0·008	-0·009	-0·010	+0·038	+0·047	+0·058	+0·069
100	+0·000	+0·004	+0·009	+0·015	+0·022	+0·030	+0·171	+0·189	+0·209	+0·229
200	+0·031	+0·093	+0·107	+0·122	+0·148	+0·164	+0·397	+0·426	+0·455	+0·486
300	+0·250	+0·272	+0·295	+0·319	+0·344	+0·370	+0·728	+0·768	+0·808	+0·849
400	+0·517	+0·549	+0·583	+0·613	+0·653	+0·690	+1·17	+1·23	+1·28	+1·33
500	+0·89	+0·94	+0·98	+1·03	+1·07	+1·12	+1·75	+1·81	+1·88	+1·95
600	+1·39	+1·44	+1·50	+1·56	+1·62	+1·69	+2·47	+2·55	+2·63	+2·71
700	+2·02	+2·09	+2·16	+2·24	+2·31	+2·39	+3·35	+3·45	+3·55	+3·65
800	+2·80	+2·89	+2·97	+3·07	+3·16	+3·25	+4·41	+4·53	+4·65	+4·77
900	+3·75	+3·85	+3·96	+4·07	+4·18	+4·29				
1000	+4·89									

XLIV. *Proceedings of Learned Societies.*

GEOLOGICAL SOCIETY.

[Continued from p. 356.]

May 23rd, 1900.—J. J. Teall, Esq., M.A., F.R.S., President,
in the Chair.

THE following communications were read:—

1. 'The Igneous Rocks of the Coast of County Waterford.'
By F. R. Cowper Reed, Esq., M.A., F.G.S.

The first part of this paper is devoted to a discussion of the field-evidence, as shown by the coast-sections from Newtown Head to Stradbally. The igneous rocks there exposed are divided into the following five categories:—(a) The felsitic rocks; (b) necks of non-volcanic materials; (c) the basic sills and vents; (d) intrusions of dolerite; (e) intrusions of trachyte, andesite, etc.; (f) intrusions of other types. In regard to the age of the rocks, there appear to have been two main periods of volcanic activity: the first, in Ordovician times, was marked solely by outpourings of a felsitic nature; the second, post-Ordovician but pre-Upper-Old-Red-Sandstone, was characterized by a succession of several distinct types of igneous rocks. The lavas and tuffs, interbedded with fossiliferous rocks, have been already described. These are overlain by other felsites and ashes, developed near Great Newtown Head, which show the same dip and strike and partake in the same movements. Next occurred an outburst of green and pink felsites, tuffs and coarse agglomerates, developed from Great Newtown Head to Garrarus; and possibly the xenolithic felsites and greenish tuffs belong to the same series. It is doubtful whether these were poured out before the first folding of the Ordovician beds, but their strike, when traced inland, agrees with that of the series last mentioned. The intrusion of some irregular masses of felsite-porphry took place subsequently to the folding; it was followed by small veins of trachyte and andesite; these by basic sills, diabases, etc., and by a few dolerite-dykes and veins. Subsequently the igneous intrusions assumed an acid character, and the felsitic masses of Newtown Head, Knockmahon, etc. were extruded; probably at this time, too, were formed the isolated necks filled with brecciated fragments of the earlier rocks. The felspar-porphry dykes and isolated felsitic sheets and veins which pierce the folded rocks, particularly west of Kilfarrasy, probably belong to this late period.

The relative age of some of the peculiar types of intrusive rocks is indicated in the paper in those cases in which it can be determined. That those rocks which are later in date than the folding of the Ordovician are older than the Upper Old Red Sandstone is shown (1) by the unconformity of the Upper Old Red

Sandstone; (2) by the fact that the latter rock does not contain any interbedded igneous rocks; and (3) by the absence of felsitic or other intrusive rocks from the Old Red Sandstone of the district.

The second part of the paper is devoted to petrological notes on the different rock-types. The felsites are classified by means of their groundmass into microcrystalline, cryptocrystalline, and micro-poikilitic and other types; potash-felsites, potash-soda-felsites, and keratophyres, all appear to be present; some of these rocks are linked to the trachytes and bostonites. The diabases and dolerites are sometimes ophitic, but more usually allotriomorphic in texture. The trachytes and andesites are of various types, and some are probably keratophyres. Quartz- and felspar-porphyrries, augite-porphyrries, and several miscellaneous types are also described.

2. 'On a New Type of Rock from Kentallen and Elsewhere, and its Relations to other Igneous Rocks in Argyllshire.' By J. B. Hill, Esq., R.N., and H. Kynaston, Esq., B.A., F.G.S.

A rock originally described by Mr. Teall from Kentallen is used by the authors as a type round which they group a peculiar series of basic rocks discovered in several localities. The rocks consist essentially of olivine and augite with smaller amounts of orthoclase, plagioclase, and biotite, while apatite and magnetite are accessory. The peculiar feature of the rocks is the association of alkali-felspar with olivine and augite, and the group is related to the shonkinites of Montana and the olivine-monzonites of Scandinavia. The occurrence of the rocks is connected with four neighbouring but distinct areas of intrusion, each characterized by granites and diorites, and by dykes and sills of lamprophyres, porphyrites, etc. In these areas the new rock is the most basic type, and it occurs in the marginal portions of the areas. Close relationships exist between the different intrusive rocks in each area, so that it may be concluded that these constitute a 'rock-series' ranging from granite through augite-diorite towards the olivine-bearing rocks, in the plutonic phase, and from orthoclase-porphyr and porphyrite to augite-lamprophyre, in the dyke-and-sill phase. The whole assemblage appears to have been derived by a process of differentiation from one parent magma; and the order of intrusion has been, in the main, one of increasing acidity. There is further a 'facies-suit' in each intrusion showing progressive increase in basicity from centre to margin, due to concentration of the more basic oxides in the cooler portions of the magma, which was originally of intermediate composition; from this 'complementary rocks' were produced. It is extremely probable that the underlying magmas of the four intrusive areas resembled one another more or less closely in composition.

THE
LONDON, EDINBURGH, AND DUBLIN
PHILOSOPHICAL MAGAZINE
AND
JOURNAL OF SCIENCE.

[FIFTH SERIES.]

NOVEMBER 1900.

XLV. *On the Action of the Coherer.* By T. MIZUNO*.

SINCE the discovery that when a metallic powder is exposed to the influence of electric radiation its electric resistance undergoes alteration, many investigators have attacked the problem by various methods. It is, however, not necessary to mention one by one all the names of the investigators and the results at which they have arrived. It may suffice to notice that the results tend to show that the action of the coherer is correlated in some way to microscopic sparks induced in an assemblage of fine metallic particles in virtue of the action of electric waves; that is to say, these sparks might give rise to "welding" action, whereby conducting chains of particles are formed, and consequently the resistance of the coherer greatly reduced.

Now the author thought that in order to make the so-called welding-theory more definite, a thorough systematic study of the subject was necessary, and also that such study might add some interesting facts to our knowledge of the action of the coherer. Accordingly a series of experiments was undertaken on a number of metals, some alloys, and also their mixtures. The experiments were conducted in the following manner:—

The source of electric waves was a Hertzian parabolic vibrator, emitting electric waves of about 60 cms. wavelength. The coherer consisted of a glass tube about 5 cms. in length, 5 mms. in diameter, having two movable and finely-adjustable small pistons, between which the metallic powder under question could be introduced. To the extremities of the pistons were respectively attached wires

* Communicated by the Author.

which led to the arms of a Wheatstone's bridge. The galvanometer used was a Kelvin's astatic double-coil one. The bridge-current was supplied by a single Daniell cell, the resistance, ranging between 1000 and 2000 ohms, being always inserted in the circuit before the current entered the arms of the bridge. This precaution was, as I found, especially requisite, because when the current exceeded a certain strength, the resistance of the coherer often underwent very marked spontaneous fluctuations during the repeated processes for balancing the bridge. This phenomenon was perhaps due to the self-induction effect of the galvanometer-coil.

Taking the above precaution, I have made a general survey of metals, some alloys, and their mixtures. So far as I am aware, all the investigators of the coherer simply measured the change of its resistance under the action of a given electric radiation, but did not, any of them, go so far as to examine the successive states of affairs under repeated radiations. My method of procedure was entirely different, and I studied the history, so to speak, of the successive changes of the resistance of the coherer accompanying successive oscillating sparks of the Hertzian vibrator. The results obtained with the several metals, alloys, and their mixtures respectively are tabulated and also plotted in the following tables and diagrams:—

TABLE I.

Number of Sparks.	Brass.	German Silver.	Electric Fuse.	Soldering Fuse.	Rose's Metal.	Wood's Metal.
0	∞	∞	∞	∞	∞	∞
1	262·0	150	87·0	45·4	122·0	43·0
2	146·0	132	∞	44·3	66·0	52·0
3	86·0	149	121·0	47·3	61·7	46·0
4	91·2	114	59·0	78·0	"	42·0
5	80·0	110	56·3	34·0	67·0	"
6	79·3	97	55·2	33·7	65·0	41·7
7	78·9	96	"	"	64·4	41·5
8	"	"	54·6	"	67·0	"
9	74·1	97	53·0	"	60·0	"
10	83·4	99	"	33·9	"	"
11	77·4	102	"	"	59·0	"
12	"	99	52·9	"	"	"
13	79·3	101	"	"	"	"
14	"	"	52·7	37·0	"	41·2
15	82·0	104	"	"	"	"
16	80·3	103	53·3	"	"	"
17	79·9	100	52·5	"	"	"
18	"	102	52·2	"	"	"
19	"	100	51·4	"	"	"
20	84·0	99	∞	"	"	"
25	58·7	—

TABLE II.

Number of Sparks.	Platinum.	Iron.	Nickel.	Steel.	Copper.	Silver.	Aluminium.	Antimony.
0	∞	∞	∞	∞	∞	∞	∞	∞
1	146.4	84.7	38.0	117.0	162.0	29.3	57.0	174.0
2	90.2	71.0	32.4	88.0	102.7	14.0	53.0	166.0
3	90.0	71.4	34.4	87.9	93.4	13.7	35.0	166.0
4	88.5	72.4	33.1	94.0	92.0	13.5	34.0	"
5	88.2	75.4	32.4	90.0	82.0	"	33.0	"
6	88.1	79.9	22.7	77.4	"	"	30.0	"
7	85.0	77.8	22.3	73.4	87.0	"	32.0	"
8	"	77.9	22.7	70.0	81.4	"	32.3	169.0
9	80.5	79.3	23.2	73.0	"	13.2	"	"
10	80.4	78.0	24.9	"	74.7	13.5	33.0	"
11	"	82.6	26.4	72.4	74.4	13.4	34.0	165.0
12	80.0	76.2	25.4	70.7	74.3	12.9	32.0	"
13	78.7	75.2	24.7	71.5	"	"	26.0	166.0
14	"	78.0	23.9	68.5	"	13.3	"	177.0
15	79.0	82.0	24.5	70.5	"	"	"	"
16	"	88.4	25.0	"	76.7	"	"	"
17	79.1	90.4	26.0	64.7	"	"	"	"
18	79.2	94.0	26.6	63.3	75.2	12.6	25.0	"
19	79.5	92.3	26.2	64.7	"	"	"	"
20	"	76.7	17.1	66.9	72.0	"	"	"
25	79.3	90.0	15.9	28.0	—

TABLE III.

Number of Sparks.	Zinc.	Lead.	Cadmium.	Bismuth.	Tin.	Potassium.	One Lead Ball.	Two Lead Balls.
0	∞	∞	∞	∞	∞	5.7	∞	∞
1	27.5	56.3	42.0	330.0	50.0	2.5	4.0	4.4
2	27.0	"	27.2	350.0	74.0	2.8	3.8	5.0
3	27.6	55.0	22.6	"	60.0	2.4	3.7	4.5
4	43.4	"	21.0	"	48.0	"	3.8	7.7
5	35.0	"	19.5	357.0	52.0	2.2	3.9	2.3
6	"	"	"	349.0	51.0	"	"	"
7	35.1	∞	"	"	45.0	2.6	"	"
8	"	55.3	"	"	44.0	"	"	"
9	"	55.5	"	"	"	"	"	"
10	∞	53.0	20.5	"	"	2.4	"	"
11	"	49.0	21.2	"	"	2.3	"	"
12	"	"	20.7	"	"	"	"	"
13	51.3	"	"	"	"	2.2	"	"
14	52.7	"	"	372.0	"	2.5	"	"
15	"	"	"	"	"	2.2	"	"
16	43.9	"	"	"	"	2.2	"	"
17	42.1	"	"	"	"	2.3	"	"
18	"	"	"	"	"	"	"	"
19	43.7	"	"	"	"	2.4	"	"
20	45.7	"	"	"	42.4	3.0	3.8	"
25	47.0	"	"	"	"	2.4	3.9	"

TABLE IV.

Number of Sparks.	Silver + Wood's Metal.		Iron + Cadmium.		Iron + Wood's Metal.		Iron + Rose's Metal.		Iron + Silver.	
	W \div Ag.	C \div Fe.	C > Fe.	W \div Fe.	W > Fe.	R \div Fe.	R > Fe.	Fe > Ag.	Ag > Fe.	
0	∞	∞	∞	∞	∞	∞	∞	∞	∞	
1	8.3	125	44.0	125	107	235	97	67.0	8.0	
2	6.3	171	34.1	"	104	202	93	46.0	6.9	
3	"	76	29.8	"	66	198	"	40.0	7.0	
4	"	116	27.0	101	63	183	90	46.7	"	
5	"	74	"	108	62	185	86	48.4	6.9	
6	"	61	26.4	100	58	184	"	50.0	7.2	
7	5.5	57	"	105	55	171	95	53.0	7.0	
8	"	58	"	134	"	176	83	48.0	"	
9	"	"	26.0	120	"	"	"	41.0	"	
10	"	"	"	90	"	"	"	69.0	"	
11	"	"	"	105	"	162	"	53.0	8.3	
12	"	"	"	129	"	165	"	38.0	7.9	
13	"	"	"	"	"	186	"	43.0	"	
14	"	"	"	"	"	"	"	40.0	7.7	
15	"	60	"	"	"	"	80	37.4	7.6	
16	"	56	26.4	"	"	"	"	39.4	7.4	
17	"	"	"	"	"	"	"	47.7	7.3	
18	"	"	"	"	"	"	87	49.7	"	
19	"	"	"	146	"	199	83	47.0	"	
20	"	"	29.0	117	62	"	"	"	"	
25	"	53	26.4	"	60	"	"	41.3	"	

In the above tables the first columns show the number of sparks, and the other columns give the successive values of the resistance of the several coherers respectively. Here by "number of sparks" I mean the number of the oscillating

Fig. 1.

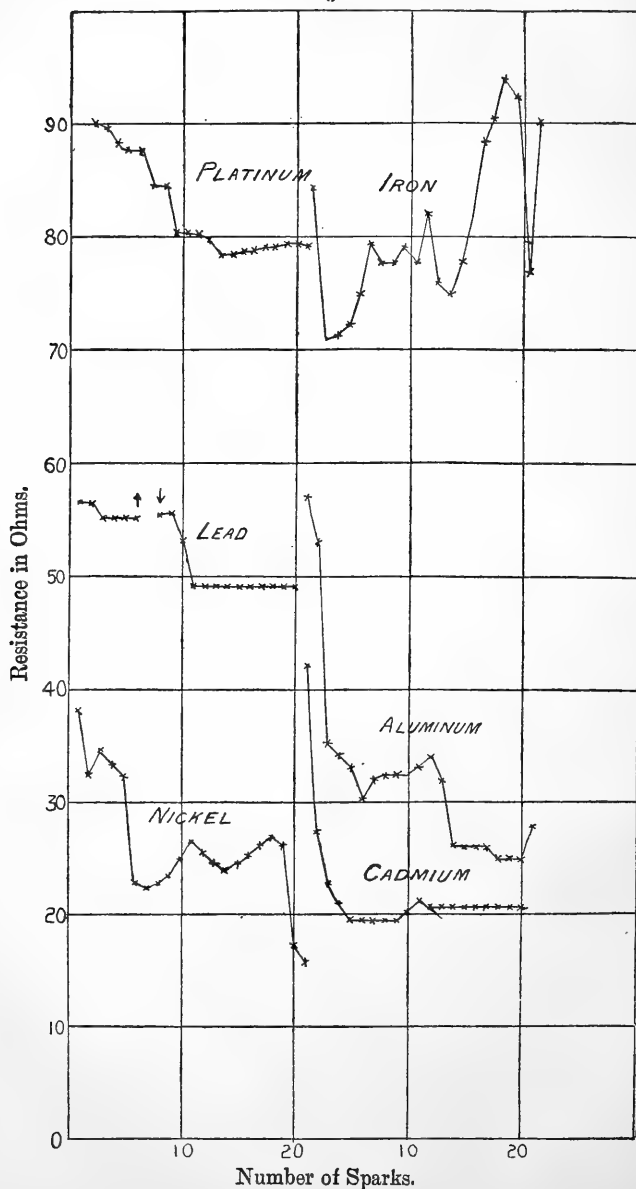

sparks counted from the first, so that the number simply gives the historical stage of the successive sparks. It is also to be remarked that the signs of inequality and approximate equality are used in Table IV. to indicate the relative quantities of the constituent metals.

Fig. 2.

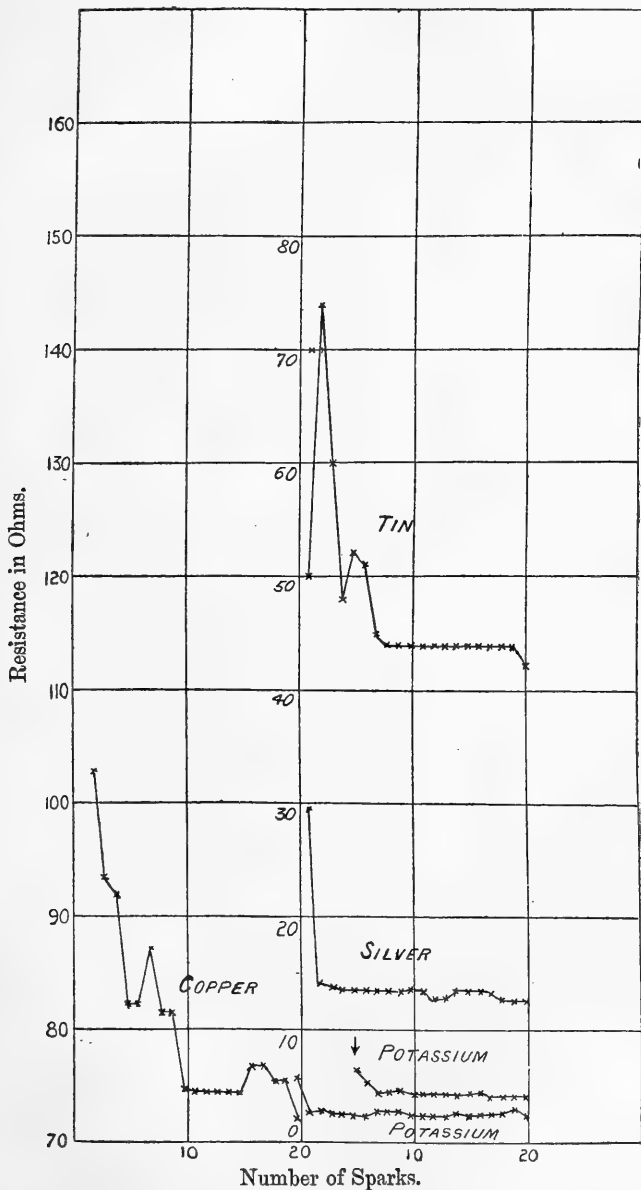

Fig. 3.

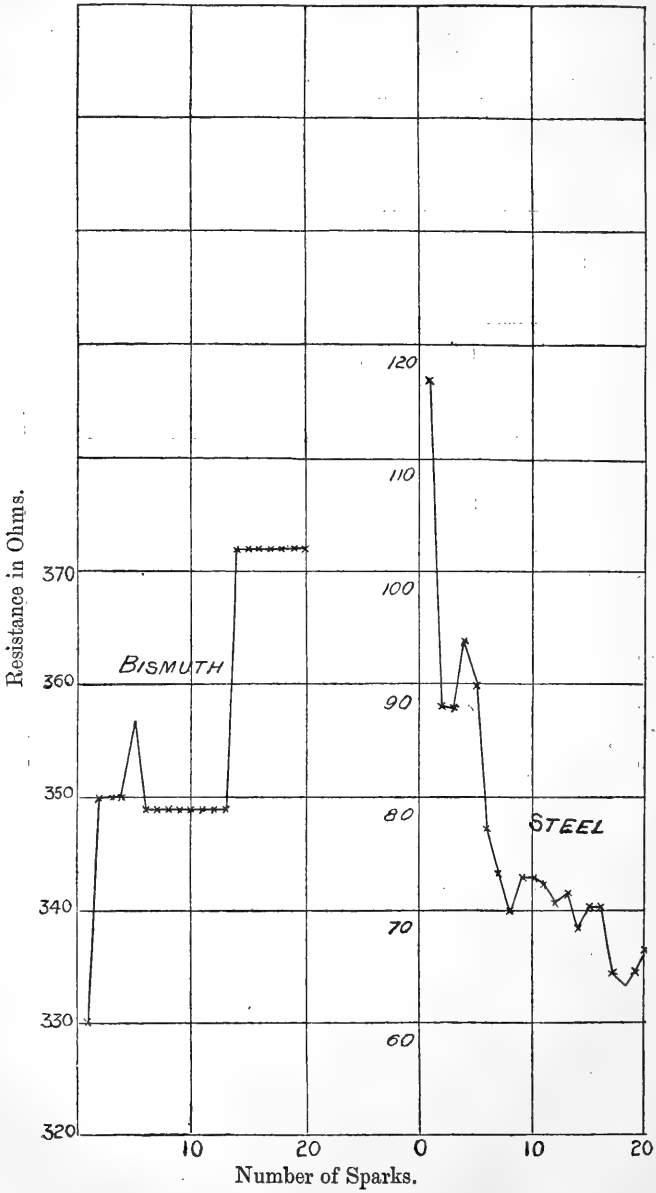

Fig. 4.

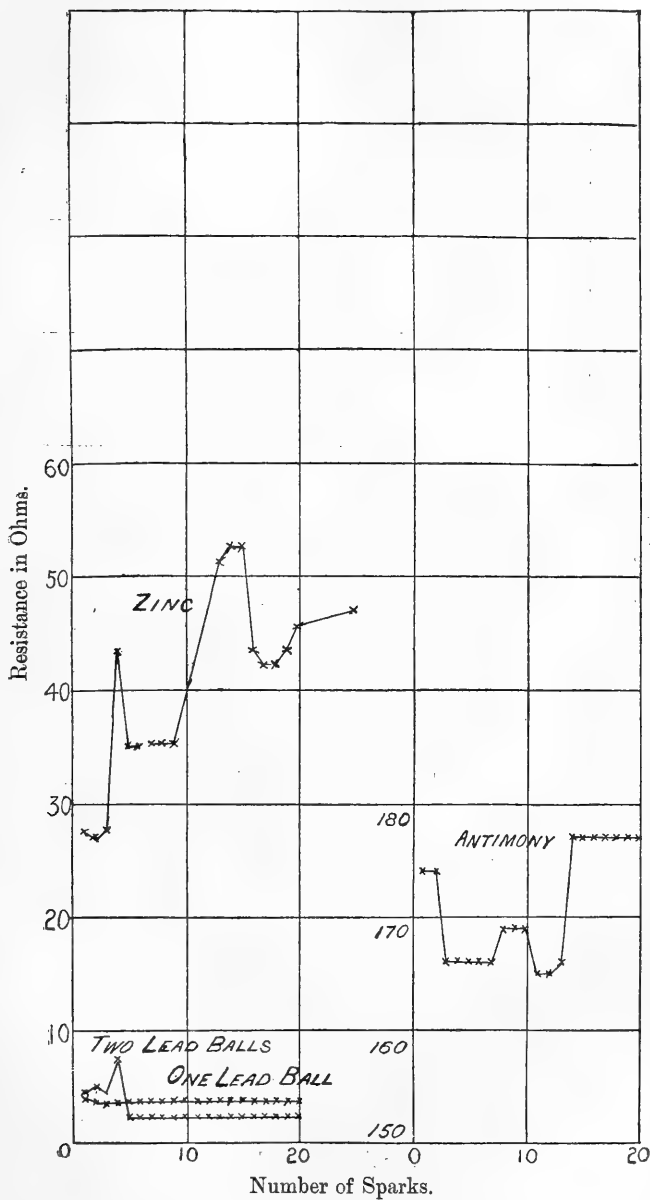

Fig. 5.

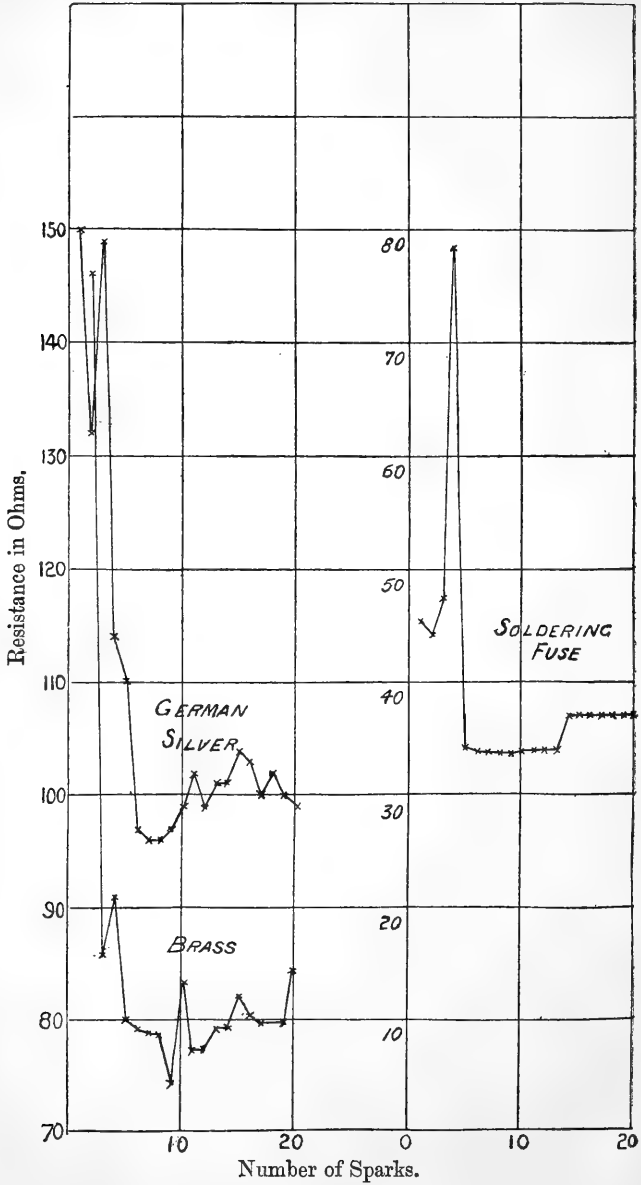

Fig. 6.

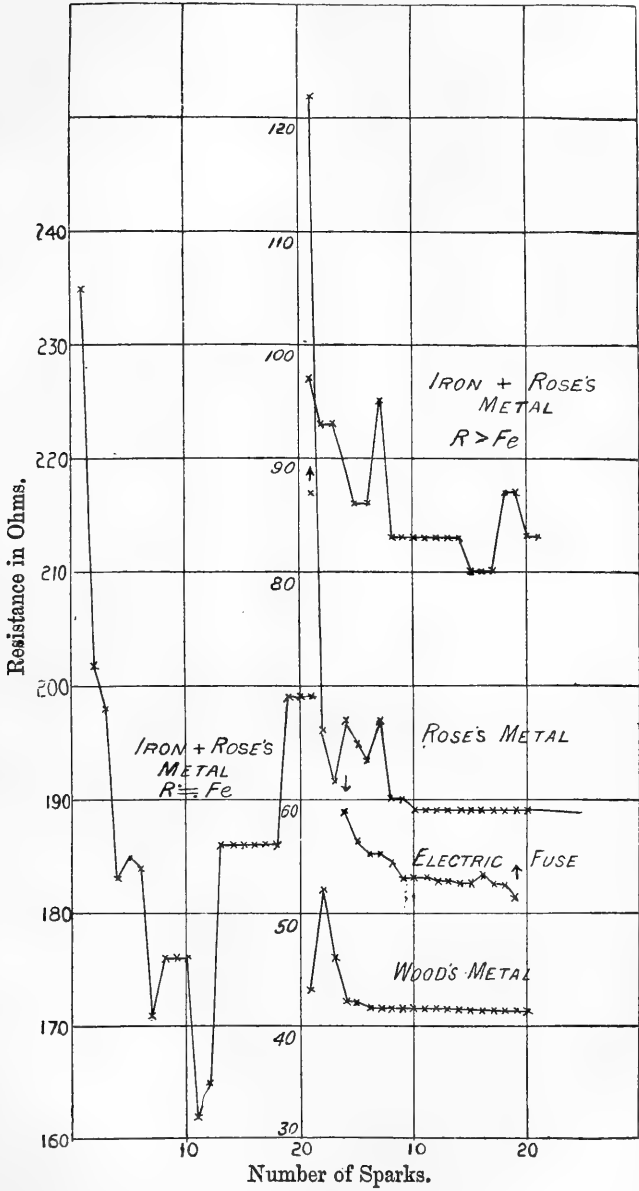

Fig. 7.

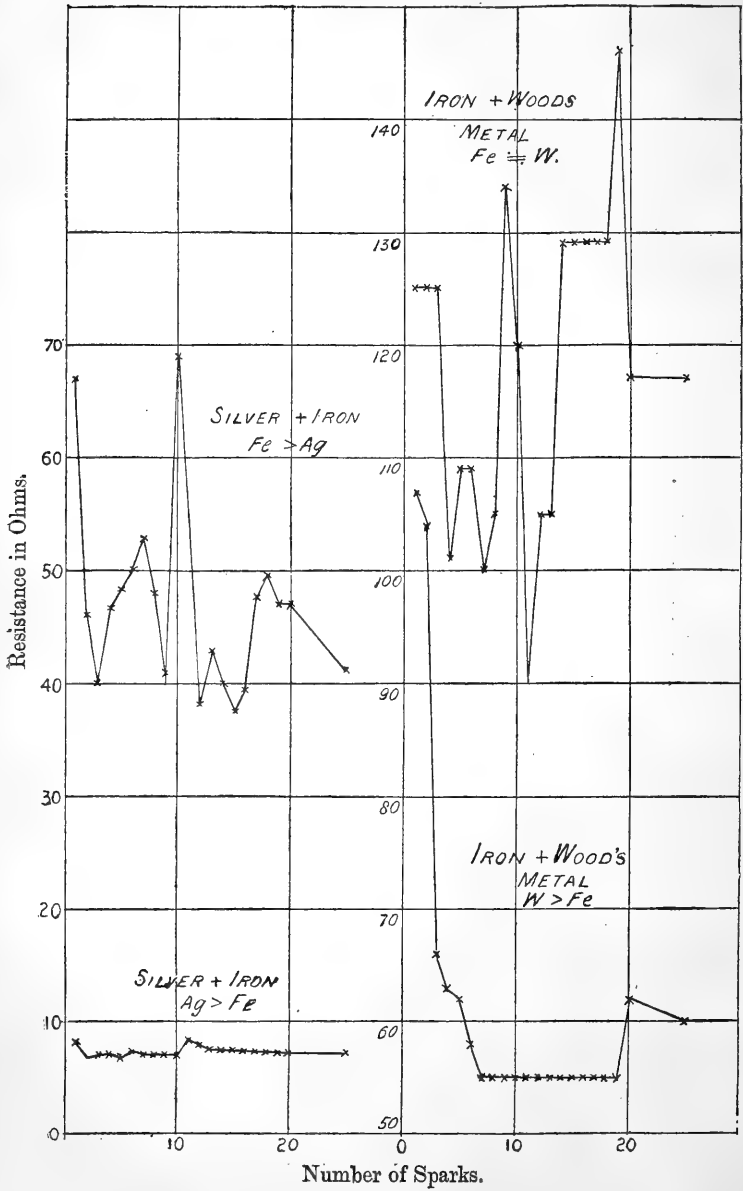
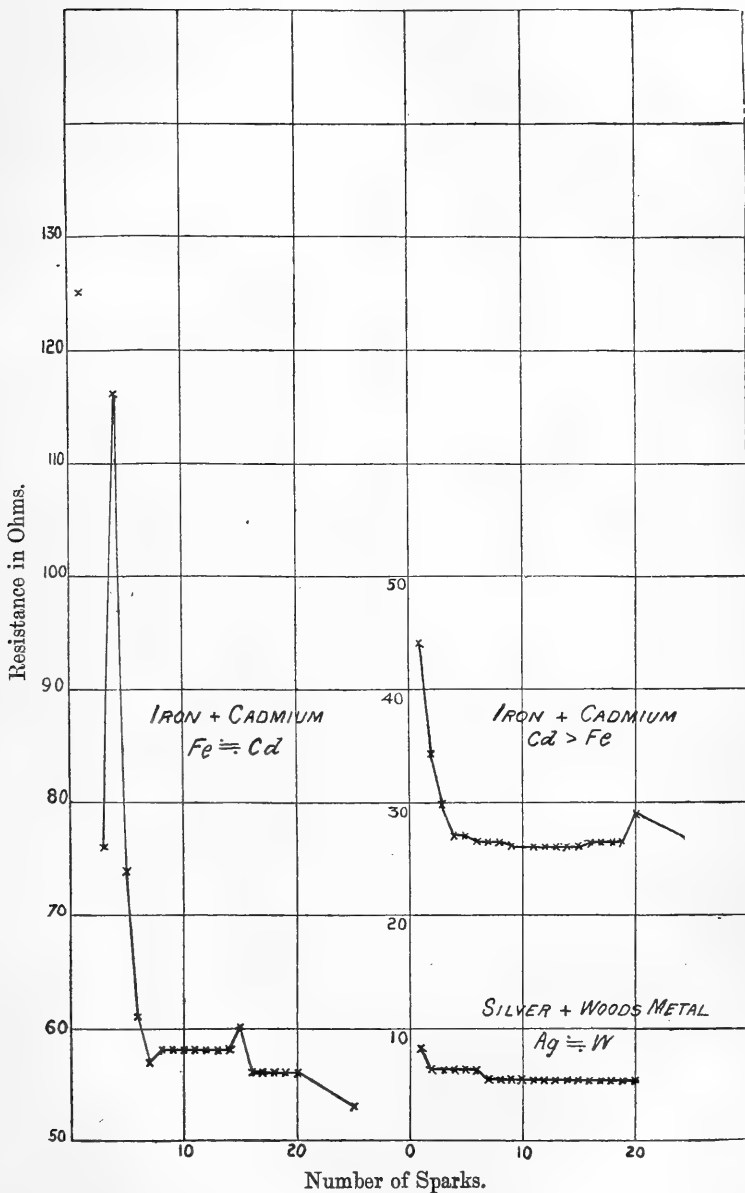

Fig. 8.



The chief results obtained from the above experiments may now be summed up as follows:—

- (1) In platinum, lead, nickel, aluminium, cadmium, copper, silver, steel, and potassium coherers, the action of electric waves is to reduce their resistances at first to a large extent, and then this reduction continues, though with some intermediate rise and fall, until the resistances assume certain final values.
- (2) In the case of iron, tin, bismuth, zinc, and antimony coherers, their resistances are diminished at first, but soon afterwards the changes become very irregular, the diminution and increase occurring at random. It is very interesting and also important to notice that with the iron coherer the action is conspicuously irregular.
- (3) With one and also two small lead-ball coherers, the resistance attains its final value very rapidly, so that the successive stages of their histories present nothing conspicuous.
- (4) In the alloys, namely german-silver, brass, electric fuse, ordinary soldering fuse, Rose's and Wood's metals, the general tendency is to the reduction of their resistances to certain limiting values, though with more or less irregularity.
- (5) In the case of the coherers with the mixed metals, namely iron with silver, cadmium, Rose's and Wood's metals respectively, and also silver with Wood's metal, the mode of change of resistance seems to be chiefly governed by the percentage ratios of the constituents. In fact, the history of each coherer, as will be seen from the figures, presents the character which would belong to the predominating constituent.
- (6) With zinc, lead, potassium, and electric fuse, we find that the resistance suddenly assumes infinite value at a certain stage during the experiment.

Judging from the above results, it appears to me that the action of the coherer might, in reality, be due to something like welding which would take place on a small scale among fine metallic particles in virtue of the induced microscopic sparks. In fact I found that the lowering of resistance seems to be greatly determined by the melting-point of each metal and alloy; that is to say, the lower the melting-point the greater the reduction is.

Of course it is here to be remembered that evidently this reduction also depends upon the specific electric conductivity.

For example, in the case of very easily fusible metals, namely, Wood's and Rose's metals, the reduction comes out

rather smaller than expected; and this is perhaps due to the comparatively bad electric conductivities of the metals. Now according to the above-assumed theory of welding, it follows naturally that such a metal, possessing good electric conductivity while at the same time its melting-point is not very high, would suffer a marked reduction in its resistance. The experimental results, so far as I have found out, seem to point to such a conclusion. It was thought that it would be interesting to ascertain whether the behaviour of coherers can be modified freely by properly mixing one kind of metallic powder with another, or not. To do this it is natural to select metals whose behaviours are very marked, that is to say, those metals which are either very irregular or very smooth in their action under the influence of electric radiations. In this respect iron belongs to the first, while silver, cadmium, Rose's and Wood's metals belong to the second class. Hence, as shown in the foregoing Table IV., the iron powder was respectively coupled with the just-mentioned metals, and also the couple of the two, so to speak, inactive metals, that is silver and Wood's metal, was formed.

Experimenting on such mixed coherers, the author found that the irregularity in the behaviour of iron could be actually smoothed at will by taking a greater mass of the coupled metal. Again, here I have to draw attention to the fact that with all the metals and alloys investigated the resistance did not necessarily undergo diminution, but often increased during the experiment; and also that in the case of some metals and alloys the increase went up even to infinity.

How are these phenomena to be accounted for? Is it not possible to conceive a state of affairs such that, in one case, some of the conducting chains once formed by melting disintegrate, while in the other case the chains, acting somewhat like fuse, suffer complete break under the impulse of electric radiations?

Of course by "welding" I do not always necessarily mean electrical welding in its strict sense; but it might even, perhaps, be sufficient to simply assume a certain process of melting in order to account for the said phenomena. Though the hidden mechanism of the coherer still remains for further complete investigation, yet I venture to say that such a survey as I have made of the successive stages in the history of each of the several coherers appears, at any rate, to be of no little scientific value.

Lastly, it is to be noticed that the above experiments were performed during the last winter at the Physical Laboratory of Kyoto Imperial University, Kyoto, Japan.

Berlin, July 1900.

XLVI. *The Molecular Constitution of Water.*
By WILLIAM SUTHERLAND*.

THE two chief irregularities in the physics of water, namely, its temperature of maximum density near the solidifying point, and its great expansion on solidification, seem to have long ago suggested the idea that water is a mixture of two substances, whose proportions vary with the temperature. In 1892 Röntgen (*Wied. Ann.* xlv.) in an elegant but brief paper, showed that qualitatively all the prominent exceptional properties of water could be accounted for by considering water at different pressures and temperatures to be a saturated solution of ice in some other form of H_2O . It seemed to me that sufficient data were in existence to enable one to work out quantitatively the actual constitution of water; and I propose to show that steam being H_2O , ice is pure $(H_2O)_3$ and water a mixture of $(H_2O)_3$ and $(H_2O)_2$ in proportions whose dependence on temperature can be expressed by a simple formula. As H_2O is very generally used as a symbol for water, and as hydrogen oxide is a long name for so important a chemical species as H_2O , I propose for international convenience to call H_2O hydrol, $(H_2O)_2$ dihydrol, and $(H_2O)_3$ trihydrol. Steam is hydrol, ice is trihydrol, and water a mixture of dihydrol and trihydrol. The investigation will be taken in the following order:—

1. Constitution of water from its thermal expansion.
2. Confirmation from optical refraction.
3. Compressibility of water and dissociation of trihydrol into dihydrol by pressure.
4. Surface-tension and constitution of water in surface-film.
5. Latent heat of fusion, specific heat, and latent heat of evaporation.
6. The viscosity of water.
7. Dielectric capacity.
8. The melting of ice as a phenomenon of dissociation, and the higher valency of oxygen.
9. Summary of results.

1. *Constitution of Water from its Thermal Expansion.*

The starting point in this section is Mendeléeff's empirical approximate formula for the thermal expansion of liquids between $0^\circ C.$ and their boiling-points, namely, $\rho = \rho_0(1 - kt)$, which, expressed graphically, as in the figure, with t for

* Communicated by the Author.

abscissa and ρ for ordinate, gives a straight line such as XY for an ordinary liquid. But the corresponding graph for water is like the curve CDE in which the ordinate DN represents the maximum density at about 4° C. If the actual data are plotted on a large scale, the branch DE looks as if it

Fig. 1.

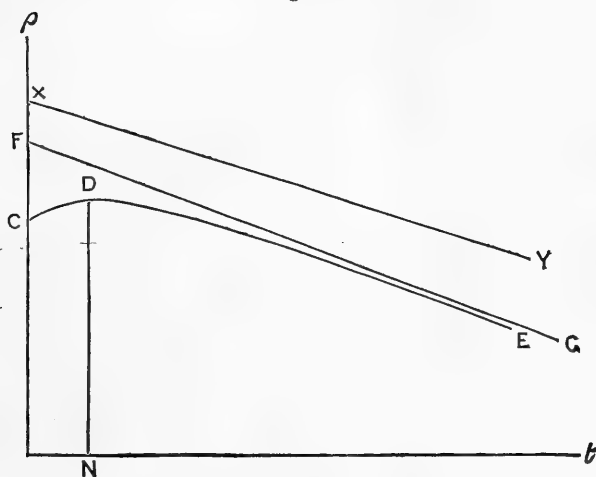

approached asymptotically the straight line FG. The reasonable course is then to assume that this asymptote represents the behaviour of one of the pure ingredients of water. The slope of this asymptote gives for k the value $\cdot 001$, which is of the same order as k for ordinary liquids, and the asymptote cuts the axis of ρ in a point which gives for ρ_0 for the pure ingredient a value about 1.083.

Guided by these facts and by theoretical considerations, I sought to obtain an equation for CDE which would give the value of ρ for the other ingredient, and also a law of the dissociation of one ingredient into the other at different temperatures. A preliminary attempt gave a formula which expressed the variation of ρ with t to within 1 part in 10,000; but as Mendeléeff (*Phil. Mag.* [5] xxxiii.) had already furnished an empirical formula for the expansion of water correct to 4 parts in 100,000, it seemed best to examine his formula in the light of the foregoing considerations. It is

$$\rho = 1 - \frac{(t-4)^2}{1.9(34.1+t)(703.51-t)}, \quad \dots \quad (1)$$

which, with the fact that $1/1.9 = 1/2 + .02632$, may be written

$$\rho = 1 + \frac{1}{2} - \frac{.45896}{1-t/703.51} + .02632 - \frac{.067485}{1+t/94.1} \dots \quad (A)$$

To interpret this we must suppose water at 4° C. to be for the present a standard mixture of the two ingredients in water, and that water at any other temperature is formed by adding a certain proportion of one of the pure ingredients to this standard mixture. Let us denote this standard mixture by S, its density at any temperature by ρ_s , and at 0° by ${}_0\rho_s$, while ρ_1 and ${}_0\rho_1$ relate to the pure ingredient which we shall call 1. Then for a mixture of $1/2 + q$ parts by weight of S with $1/2 - q$ parts of 1 formed without shrinking, we should have a density ρ given by

$$\frac{1}{\rho} = \frac{1/2 - q}{\rho_1} + \frac{1/2 + q}{\rho_s} = \frac{1}{\rho_s} + (\frac{1}{2} - q) \left(\frac{1}{\rho_1} - \frac{1}{\rho_s} \right), \dots \quad (2)$$

$$\therefore \rho = \rho_s \left\{ 1 - (\frac{1}{2} - q) (\rho_s/\rho_1 - 1) + (\frac{1}{2} - q)^2 (\rho_s/\rho_1 - 1)^2 + \dots \right\},$$

Now for S and 1 we shall have approximately

$$\rho_s = {}_0\rho_s(1 - k_s t), \quad \rho_1 = {}_0\rho_1(1 - k_1 t),$$

$$\begin{aligned} \therefore \rho &= {}_0\rho_s \left[1 + \frac{1}{2} - \frac{1}{2} \frac{{}_0\rho_s}{{}_0\rho_1} \left\{ 1 + (3 \frac{{}_0\rho_1}{{}_0\rho_s} - 2) k_s t + k_1 t \right\} \right. \\ &\quad \left. + q \left\{ \left(\frac{{}_0\rho_s}{{}_0\rho_1} - 1 \right) (1 - k_s t) - \frac{{}_0\rho_s}{{}_0\rho_1} (k_s - k_1) t \right\} + \dots \right] \\ &= {}_0\rho_s \left[1 + \frac{1}{2} - \frac{{}_0\rho_s/2{}_0\rho_1}{1 - t \left\{ (3{}_0\rho_1/{}_0\rho_s - 2) k_s' + k_1' \right\}} \right. \\ &\quad \left. + q \left\{ \left(\frac{{}_0\rho_s}{{}_0\rho_1} - 1 \right) (1 - k_s t) - \frac{{}_0\rho_s}{{}_0\rho_1} (k_s - k_1) t \right\} \right], \dots \quad (B) \end{aligned}$$

where k_s' and k_1' ought to be nearly equal to k_s and k_1 and are used to bring our expansion back to a form suitable for comparison with Mendeléeff's empirical equation in its form (A). In the sequel they will be taken as k_s and k_1 .

A comparison of (A) and (B) gives

$${}_0\rho_s = 1, \dots \dots \dots \quad (3)$$

$${}_0\rho_s/2{}_0\rho_1 = .45896 \quad \therefore {}_0\rho_1 = 1.08942, \dots \dots \dots \quad (4)$$

$$(3{}_0\rho_1/{}_0\rho_s - 2) k_s' + k_1' = 1/703.51$$

$$\therefore 1.2683 k_s + k_1 = .0014214, \dots \dots \dots \quad (5)$$

$$\begin{aligned} .02632 - \frac{.067485}{1+t/94.1} &= q({}_0\rho_s/{}_0\rho_1 - 1)(1 - k_s t) - t(k_s - k_1) {}_0\rho_s/{}_0\rho_1 \\ &= -.08208q(1 - k_s t) - .91792(k_s - k_1)t. \quad (6) \end{aligned}$$

The value 1.08942 for ρ_1 the density at zero of one of the pure ingredients agrees with the value indicated by the asymptote in the figure, and the law of dissociation of our standard mixture S at different temperatures is given by (6), to which we shall return when we have determined the composition of our standard mixture. We shall neglect in it the small terms and write it

$$q = \frac{.8222}{1 + .010627t} - .3207. \quad (7)$$

In this form it gives for $q=1/2$, $t=-.06^\circ$ instead of 4° as the temperature at which the percentage of 1 added to S is 0; this is the result of neglecting the small terms, and is of no importance in the study of q at present. For $q=0$, that is for a mixture of equal parts of 1 and S, $t=147$. The largest possible negative value of q is when $t=\infty$ and is $-.32$, so that obviously the formula does not include in its range the case of $q=-1/2$, that is of the complete dissociation of water into the pure substance 1. Nor should the formula be expected to do so, as its empirical range is only to the boiling-point, though it may be used for purposes of approximation up to nearly 200 degrees.

To determine the composition of S we shall now consider another remarkable exceptional property of water, namely, its large expansion upon solidification. According to Bunsen unit volume of water at 0° becomes 1.09082 of ice at 0° , and notwithstanding this considerable forcing apart of the molecules of water against their mutual attractions, for which we should expect that energy would have to be put into water to solidify it, we find actually that energy or heat has to be taken out of water to change it to ice. For comparison we can consider the expansion of metals and phosphorus when they melt. According to Vicentini and Omodei (*Wied. Beibl.* xii.) a volume 1000 of each of the following increase by

Pb.	Cd.	Sn.	Na.	K.	P.	Hg.
34	47	28	25	26	35	37

Therefore there is on the average an expansion of such solids on melting by 3.3 per cent., whereas with water there is a contraction of 8.3 per cent. These facts alone are enough to suggest that the solidifying of water into ice is no mere physical change of state, as with most melting bodies, but is chiefly a profound chemical change. This view of the melting of ice will be gone into fully in sections 5 and 8, and in the meanwhile we shall assume that water in solidifying changes entirely into its other pure ingredient, which we

shall denote by 2. This in its solid form as ice has a density $\cdot91662$, and if it could expand without dissociation would probably expand like a melting metal by about 3 or 4 per cent., so that the density of our second pure ingredient as a liquid at 0 ought to be about $\cdot88$. If, then, this is mixed with the pure ingredient 1 having density $1\cdot08942$ to produce without shrinkage our standard mixture S of density 1 (nearly) at 0, it is easy to calculate what part p_2 of it by weight has to be mixed with $p_1 = 1 - p_2$ of 1 by the equation

$$1 = p_2/\cdot88 + (1 - p_2)/1\cdot089, \quad \dots \quad (8)$$

$$\therefore \text{at } 0, \quad p_2 = \cdot375$$

$$\text{and at } t, \quad p_2 = \cdot375(1/2 + q), \quad \dots \quad (9)$$

because water at temperature t contains $1/2 + q$ parts of S in one part of water, and therefore it contains $\cdot375(1/2 + q)$ parts of 2 in one part of water, q being $1/2$ almost at 0° . In the following table are given the fraction p_2 of ingredient 2 (trihydrol) in one part of water at different temperatures, the values of q according to (7) being also included.

TABLE I.

$t \dots$	0°	20°	40°	60°	80°	100°	120°	140°	198°
$q \dots$	$\cdot5$	$\cdot357$	$\cdot256$	$\cdot181$	$\cdot123$	$\cdot087$	$\cdot040$	$\cdot010$	$-\cdot061$
$1000 p_2 \dots$	375	321	284	255	234	217	203	191	165

In using the formulæ to calculate values for 198° we are extrapolating beyond their proper range, and must take such values as first approximations only. It is evident from these numbers that at the critical temperature of water, which is about 368° C., water must consist of nearly pure ingredient 1 which we shall prove in section 4 to be dihydrol. Now Thorpe and Rücker have furnished a convenient approximate relation between the coefficient of expansion of a liquid and its critical temperature (*Journ. Chem. Soc.* xlv.), namely,

$$\frac{v_0}{v_t} = \frac{1\cdot99T_c - T}{1\cdot99T_c - 273}, \quad \dots \quad (10)$$

where v_0 and v_t are volumes at 0° and t C., while T_c is the absolute critical temperature, which for dihydrol is 641 . Thus, then, for this liquid we have

$$\frac{v_0}{v_{100}} = \cdot900 = 1 - 100k_1, \quad \therefore k_1 = \cdot001,$$

which agrees with the value found graphically by means of the asymptote. Accordingly, from (5) we have $k_s = \cdot 00033$.

But S is a mixture of $\cdot 375$ parts of 2 and $\cdot 625$ of 1, and thus

$$v = \cdot 375v_2 + \cdot 625v_1;$$

$$\therefore \text{at } 0^\circ \quad \frac{dv}{dt} = \cdot 375k_2/\rho_2 + \cdot 625k_1/\rho_1. \quad \dots \quad (11)$$

With $\cdot 00033$ as the value of dv/dt at 0° , and the values of ρ_1, ρ_2 , and k_1 , this gives a negative value for k_2 . This is undoubtedly wrong. One cause of the error may be that we have got too large a value of k_1 by Thorpe and Rücker's approximate formula; another cause may be that 1 and 2 do not mix without shrinking, as assumed in establishing (B), a very small change in the neglected shrinkage at different temperatures would modify considerably the meanings of k_1 and k_2 as they appear in (B), which has been forced into the form of Mendeléeff's empirical equation. Indeed our process of getting (B) into a form the same as (A) tends to make the separation of the true coefficients of expansion difficult. The following method of proceeding for k_1 and k_2 seems safer. According to Plücker and Geissler (*Pogg. Ann.* lxxxvi.) the coefficient of cubical expansion of ice is $\cdot 000157$, and according to Hagen (*Wied. Ann.* xxxix.) the coefficients of Na and K on melting increase by $\cdot 3$ of their values; so by analogy we shall take the coefficient of liquid trihydrol to be about $\cdot 0002$. With this in (11) and (5) we get $k_1 = \cdot 00076$. I shall adopt $\cdot 0009$ as a reasonable compromise for the value of k_1 , retaining $\cdot 0002$ as the value of k_2 . This seems small, but as I hope to show that the melting-point of ice is not the true physical melting-point of trihydrol, but its temperature of dissociation, we can take $\cdot 0002$ as the coefficient of trihydrol below its true melting-point, in solution in dihydrol; the analogy just used with melting Na and K was intended to provide an allowance for increased molecular freedom in the liquid state, without implying that the melting of ice is a true physical melting like that of these metals.

2. Confirmation from Optical Refraction.

Before going farther it is important to confirm our conclusion that water is a mixture of liquids 1 and 2 in proportions given by Table I., and at the present stage an optical method is most appropriate. For a mixture of p_1 parts by weight of a liquid of refractive index n_1 with p_2 parts of a

liquid of index n_2 , we have its index n given by the Lorenz-Lorentz formula

$$\frac{1}{\rho} \frac{n^2 - 1}{n^2 + 2} = \frac{p_1}{\rho_1} \frac{n_1^2 - 1}{n_1^2 + 2} + \frac{p_2}{\rho_2} \frac{n_2^2 - 1}{n_2^2 + 2}, \quad \dots \dots \dots (12)$$

$$= \frac{1}{\rho_1} \frac{n_1^2 - 1}{n_1^2 + 2} + p_2 \left(\frac{1}{\rho_2} \frac{n_2^2 - 1}{n_2^2 + 2} - \frac{1}{\rho_1} \frac{n_1^2 - 1}{n_1^2 + 2} \right), \quad (13)$$

so that $(n^2 - 1)/(n^2 + 2)\rho$, say R , is a linear function of p_2 ; therefore we shall tabulate the values of this expression at different temperatures for water and the values of p_2 from Table I. side by side, and also the values of their respective successive differences denoted in the next table by ΔR and Δp_2 . The indexes n for water are those of Ketteler (Wied. *Ann.* xxxiii.) and for ice that of Pulfrich (Wied. *Ann.* xxxiv.), and the densities are the mean values given by Mendeléeff.

TABLE II.

t	Ice.	Water.					
	0°	0°	20°	40°	60°	80°	100°
10°R	209680	206342	206208	206108	206051	206016	206015
10° p_2	1000	375	321	284	255	234	217
10° ΔR	3338	134	100	57	35	1	
10° ΔR calc....	3338	185	95	52	9	-12	
10° Δp_2	625	54	37	29	21	17	

It will be noticed that the values of $\Delta(n^2 - 1)/(n^2 + 2)\rho$ and of Δp_2 run a similar course, but that the former tend to diminish to a 0 value more rapidly than the latter. This is connected with an interesting fact that water differs from ordinary liquids in showing a diminution of $(n^2 - 1)/(n^2 + 2)\rho$ with rising temperature, whereas it usually increases. Thus Lorenz (Wied. *Ann.* xi.) finds it to increase by the following number of parts in 10,000 for the following liquids from 10° to 20°:—ethyl oxide 8, chloroform 4, ethyl iodide 5, ethyl acetate 11, carbon disulphide 12. It appears, therefore, that in water this normal temperature effect of an increase has superposed on it a diminution due to the changing composition of water; the result being that in water $(n^2 - 1)/(n^2 + 2)\rho$ is nearly stationary at 80° and 100°. In the case of water then $\Delta(n^2 - 1)/(n^2 + 2)\rho$ consists of two parts, one proportional to increase of temperature Δt like those just given for ordinary liquids, and the other proportional to Δp_2 , thus

$$\Delta(n^2 - 1)/(n^2 + 2)\rho = \cdot 00000515\Delta t + \cdot 00534\Delta p_2,$$

Δp_2 being negative when denoting a diminution. The values of ΔR marked "calculated" in the last table are derived from the values of Δp_2 by this formula. Ketteler considers his values of n reliable to within a few units in the fifth decimal place, which implies that we should not have given the values of $10^6 R$ to more than five figures, and should not expect our values of $10^6 \Delta R$, as calculated, to agree closer than within a few units in the tens place of digits with the found values, as the table shows to be actually the case. Thus for the two ingredients of water the temperature effect for 10° seems to be an increase of about 2.5 parts in 10,000, and with this taken into account the composition of water as determined optically is in agreement with that found from its expansion. For $(n^2-1)/(n^2+2)\rho$ for 2 (trihydrol) and 1 (dihydrol) we have by (13) the values

$$\cdot 20968 \quad \text{and} \quad \cdot 20434.$$

3. Compressibility of Water and Dissociation of Trihydrol into Dihydrol by Pressure.

One of the peculiarities of water is that its compressibility at low pressures diminishes with temperature to a minimum and then increases. Denoting volume of a gramme by v we can write the mixture formula for volume

$$v = p_1 v_1 + p_2 v_2, \quad . \quad . \quad . \quad . \quad (14)$$

and denoting pressure by f we have

$$\frac{dv}{df} = p_1 \frac{dv_1}{df} + p_2 \frac{dv_2}{df} + (v_2 - v_1) \frac{dp_2}{df}. \quad . \quad . \quad (15)$$

In this equation we have dv/df from the experimental compressibilities of water at different temperatures, we know p_1 and p_2 from previous sections, and also $v_2 - v_1$, but there remain three unknowns dv_1/df , dv_2/df , and dp_2/df , and their variations with temperature are also unknown. To get farther it is necessary that we should estimate the compressibilities of our two ingredients. I propose to do this for 1 (dihydrol) in the following manner. In "The Laws of Molecular Force" (Phil. Mag. [5] xxxv.) I have shown that within a limited range of temperature and pressure the characteristic equation for liquids is such that

$$v^2 \Gamma \frac{df}{dT} = \frac{3}{4} l - \frac{2}{6} RvT, \quad . \quad . \quad . \quad . \quad (16)$$

approximately, where l is the virial constant or parameter of

the substance, and R the usual constant for it when a perfect gas, T the absolute temperature. Thanks to Amagat's invaluable supply of data (*Ann. de Ch. et de Phys.* [6] xxix.), I have been able to find an equation of more extensive range, but as this is still in manuscript, I shall use here the published equation referred to. In that paper, p. 276, values of M^2l for water are given, M being the molecular mass which for H_2O is 18. With the dyne as unit of force these are 11×10^{12} from the latent heat of vaporization, 9×10^{12} from the critical data, and 6×10^{12} from the capillary data. The last value was obtained on the assumption that in water the molecules consist of $(H_2O)_2$, but M in M^2l is only 18. As the latent heat of vaporization of water includes also the heat of dissociation of its complex molecules, and as the critical pressure probably has its value seriously affected by dissociation, the value 6×10^{12} must be the most nearly correct, as I have hitherto always treated it to be. Then changing to the atmo as the unit of pressure, when RT at $0^\circ C.$ has the value $11200/9$, we get for $(H_2O)_2$ or 1 at 0°

$$v^2T \frac{df}{dT} = 12790,$$

but as

$$\frac{df}{dT} = - \frac{dv}{dT} \frac{dv}{df}, \quad \therefore \frac{1}{v} \frac{dv}{df} = - \frac{1}{v} \frac{dv}{dT} \frac{df}{dT} = k\rho_0/\rho \frac{df}{dT}, \quad (17)$$

using the value of k_1 , namely $\cdot 0009$, we have for the calculated compressibility of 1 at 0° the value $\cdot 000016$. Similarly at 50° we get $\cdot 0000235$. For higher temperatures it seems to me safest to proceed thus. According to van der Waals's principle of correspondence, the compressibilities of 1 and of ethyl oxide at low pressures will always be in the same ratio to one another if taken for comparison at temperatures which are equal fractions of their absolute critical temperatures. We may take the absolute critical temperature of 1 as the same as that of water, namely 641, and that of ethyl oxide as 468. In the next table are given certain temperatures C for 1 and the temperatures C for ethyl oxide which correspond to these; then the compressibilities of ethyl oxide at these temperatures, and finally the compressibilities of 1 (dihydrol) calculated from those for ethyl oxide on the principle that the ratio at all the corresponding temperatures is that which holds for 1 at 50° and ethyl oxide at -37° , obtained by extrapolation from Amagat's data from 0° to 200° between 50 and 100 atmos.

Temp. of 1	198°	100°	90°	50°	0°
Temp. of ethyl oxide	71	-1	-8	-37	
Compr. of ethyl oxide $\times 10^5$...	28	13	10.5	8	
Compr. of 1	$\times 10^6$	82	38	31	23.5 16

In equation (15) we can use Amagat's values of the compressibility of water to give dv/df , as in the next table; from the last table we derive dv_1/df , and from Table I. p_1 , and thus get the values of $p_2 dv_2/df + (v_2 - v_1) dp_2/df$ given in the last line of the next table.

TABLE III.

Temp. C.	0°	50°	100°	198°
$10^7 dv/vdf$ for water.....	492	425	468	800
$10^7 dv/df$ for water	492	430	488	928
$10^7 p_1 dv_1/df$	93	165	301	769
$10^7 \{ p_2 dv_2/df + (v_2 - v_1) dp_2/df \}$...	399	265	187	159

It should be noticed that the compressibility we have calculated for 1 at 198° is nearly the same as that found by Amagat for water at 198°, at which temperature it ought to be nearly all 1; this, therefore, confirms our calculated compressibilities for 1. The numbers of the last row are made up of two parts, $p_2 dv_2/df$ and $(v_2 - v_1) dp_2/df$. Now p_2 has a value, .375 at 0°, which falls to .217 at 100°, so that these numbers may be said to include on the average about $\frac{1}{3}$ of dv_2/df for 2. But for a substance so near its solidifying-point as 2 is at these temperatures, .00001 would be a reasonable allowance for dv_2/df at 0°, and as dv_2/df increases while p_2 diminishes with rising temperature, .000003 may be used as an approximate value of $p_2 dv_2/df$, at all temperatures up to 100°. As we now can calculate v_2 and v_1 at all temperatures, we have $v_2 - v_1$ as given in the next table, and therefore dp_2/df given in the last row.

TABLE IV.

	0°	50°	100°
$-10^7 (v_2 - v_1) dp_2/df$	369	235	157
$10^4 (v_2 - v_1)$	2185	1869	1509
$-10^6 dp_2/df$	170	126	104

We have thus obtained estimates of the rate at which a gramme of 2 (trihydrol) is dissociated by pressure at different temperatures, namely, .00017 gramme per atmo at 0° and .0001 gramme per atmo at 100°.

We can study this dissociation from a slightly different point of view. Amagat's data (*Ann. de Ch. et de Ph.* [6] xxix.) enable us to assign the temperature of maximum density of water under 150 atmos as 5° . Although his pressures go up to 3000 atmos the maximum density has not been ascertained by him at a higher pressure than 150 atmos. Accordingly I have found the equation like Mendeléeff's which will represent the expansion of water under 150 atmos. With the volume of a gramme of water at 4° and under 1 atmo as unity it is

$$\rho = 1.00747 \left(1 + .76354 - \frac{.087724}{1 + .008375t} - \frac{.67584}{1 - .001077t} \right). \quad (C)$$

The volumes of a gramme of water as given by this formula and by Amagat, when we have changed his unit of volume to that just mentioned, are:—

TABLE V.

<i>t.</i>	0°	20°	40°	60°	80°	100°	198°
ρ formula ...	1.00745	.99489	1.00104	1.01013	1.02175	1.03568	1.1389
ρ exper.....	1.00745	.99489	1.00102	1.01012	1.02177	1.03568	1.1443

Up to 100° the equation represents the actual data with a maximum error of 2 parts in 100,000, the comparison for 198° being added to show how far the form fails when applied much beyond the ordinary boiling-point.

On comparing this last equation with Mendeléeff's for one atmo (A) and with (B), we see how the terms expressing expansion of the two ingredients and dissociation have got mixed up; a result always to be feared with empirical equations, which fact indeed makes it appear a happy accident that Mendeléeff's formula (A) is capable of such easy interpretation. We have now to disentangle the mixed up parts of the last equation. It relates to p of 1 mixed with $1-p$ parts of a mixture which we shall denote by S' (different from S). The density of S' is 1.00747, and therefore its volume is .99259, and the volume of 1 (dihydrol) as a liquid, being $1/1.08942$ at 0° under 1 atmo, is .91572 under 150 atmos when the compressibility .000016 is taken into account. Now S' also contains 2 under 150 atmos; under 1 atmo at 0 it was taken to have a volume $1/.88$, and the compressibility .00001 was conceded to it, so that its volume at 0° under 150 atmos is 1.13466; and applying the mixture formula to the density of S' we have

$$\begin{aligned} .99259 &= .91572 + (1.13466 - .91572)p_2, \\ \therefore p_2 &= .351 \text{ at } 0^{\circ} \text{ under 150 atmos. . . . } (18) \end{aligned}$$

Under one atmo we found $p_2 = \cdot 375$ at 0° , so that at this temperature $dp_2/df = \cdot 024/149 = \cdot 00016$, in fair agreement, as it ought of necessity to be, with the value found from compressibilities, namely, $\cdot 00017$.

In order to disentangle the dissociation terms of (C) from the expansion terms, we must make the dissociation produced by pressure at the different temperatures run a similar course to that in Table IV. A little arithmetic leads to

$$\cdot 07744q = \frac{\cdot 087724}{1 + \cdot 008375t} + \frac{\cdot 05398}{1 - \cdot 001077t} - \cdot 10298 \quad (19)$$

$$\frac{\cdot 46128}{1 - t(1 \cdot 252k_s + k_1)} = \frac{\cdot 62186}{1 - \cdot 001077t} - \cdot 16056.$$

In one gramme of water the amount of 2 (trihydrol) at any temperature being $\cdot 351 (1/2 + q)$, we have the following amounts of 2 under 150 atms for comparison with those under 1 atmo.

TABLE VI.

t	0°	20°	40°	60°	80°	100°
$10^3 p_2(150 \text{ atms})$	351	300	264	237	217	203
$10^3 p_2(1 \text{ atmo})$	375	321	284	255	234	217
$10^3 \Delta p_2$	24	21	20	18	17	14

Smoothing these last differences and dividing them by 150, we get:—

TABLE VII.

$10^3 \Delta p_2$	24	22	20	18	16	14
$-10^6 dp_2/df$	160	147	133	120	107	93

If the values just found for dp_2/df hold up to pressures at which the whole of 2 is dissociated, it appears that at $\cdot 375/\cdot 00016$ or about 2300 atms the whole of the 2 (trihydrol) will be dissociated at 0° ; at 100° the pressure of complete dissociation would be $\cdot 217/\cdot 000093$, also about 2300 atms. These results agree well with Amagat's conclusion that at high pressures, even below 3000 atms, the irregularities of water disappear; water becomes an ordinary liquid, that is to say, the mixture of 2 and 1 has been converted into pure compressed 1.

The effect of pressure in dissociating 2 has an important bearing on the composition of the surface-film of water. If pressure causes dissociation, tension may be expected to produce association, and therefore we may expect the proportion

of 2 to be higher in the surface than in the body of water. This will now be discussed in the next section.

4. Surface-tension and Constitution of Water in Surface-film.

The relation which I have shown to exist between the surface-tension α of a mixture and those of its ingredients (Phil. Mag. [5] xxxviii., xl.) is approximately

$$\alpha^{\frac{2}{3}}/\rho = p_1\alpha_1^{\frac{2}{3}}/\rho_1 + p_2\alpha_2^{\frac{2}{3}}/\rho_2, \quad \dots \dots \dots (20)$$

and $1/\rho = p_1/\rho_1 + p_2/\rho_2$ if there is no shrinkage,

$$\therefore (\alpha_2^{\frac{2}{3}} - \alpha^{\frac{2}{3}})/\rho_2 + p_1\{(\alpha_1^{\frac{2}{3}} - \alpha^{\frac{2}{3}})/\rho_1 - (\alpha_2^{\frac{2}{3}} - \alpha^{\frac{2}{3}})/\rho_2\} = 0. \quad (21)$$

We have also Eötvös's discovery (Wied. Ann. xxvii.) that, Mv being the volume of a gramme molecule and $\alpha(Mv)^{\frac{2}{3}}$ the molecular surface-tension σ , then $d\sigma/dt$ is nearly the same for all normal liquids, and retains a nearly constant value up to near the critical temperature, while for associated liquids of varying degree of association it is not constant. With the dyne as unit of force Ramsay and his pupils have found a mean value 2.121 for Eötvös's constant $d\sigma/dt$. Ramsay's values of $\alpha(Mv)^{\frac{2}{3}}$ or σ with $M=18$ for water (Proc. Roy. Soc. lvi. p. 177) are given in the next table with a value 0 inserted for the critical temperature and below them the values of $100\Delta\sigma/\Delta t$.

TABLE VIII.

t	0°	20°	40°	60°	80°	100°	120°	140°	368°
σ	502.9	485.3	466.3	446.2	425.3	403.5	380.7	357.0	0
$100\Delta\sigma/\Delta t$...		88	95	100	105	109	114	118	157

These values of $\Delta\sigma/\Delta t$ show no tendency towards becoming stationary at near 0°, but let us take .92 as the order of their magnitude near 0°. This when multiplied by $3^{\frac{2}{3}}$ yields 1.91, which is near enough to the 2.121 of a normal liquid to suggest that the surface-film of water at 0° consists of $(H_2O)_3$. But if this is so we should also multiply by $(1/.88)^{\frac{2}{3}}$, where .88 is the density of our ingredient 2, and this brings 1.91 up to 2.08, which is still nearer the result for an average liquid. There is, therefore, fair evidence that the tension in the surface-layer of water at 0° is sufficient to cause practically the whole of the water there to change into trihydrol, whose surface-tension is that of water at 0°, namely, 73.32 dynes per centim., and then by Eötvös's relation the surface-tension of trihydrol at any other temperature is given

by the equation

$$\alpha_2(54/\rho_2)^{\frac{2}{3}} = 73.32(54.88)^{\frac{2}{3}} - 2.121t. \quad (22)$$

With it we calculate the values of $\alpha_2^{\frac{2}{3}}$ in the next table, also tabulating Ramsay's values for $\alpha^{\frac{2}{3}}$ and obtaining $(\alpha_2^{\frac{2}{3}} - \alpha^{\frac{2}{3}})/\rho_2$.

TABLE IX.

t	0°	20°	40°	60°	80°	100°	120°	140°
$\alpha_2^{\frac{2}{3}}$	8.563	8.395	8.217	8.041	7.858	7.675	7.489	7.296
$\alpha^{\frac{2}{3}}$	8.563	8.400	8.219	8.017	7.797	7.556	7.301	7.027
$(\alpha_2^{\frac{2}{3}} - \alpha^{\frac{2}{3}})/\rho_2$	0	0	0	.028	.070	.138		

It appears from this table that up to 40° the surface-film of water consists of pure trihydrol (H_2O)₃, but that at 60° and higher temperatures the surface-tension is so much reduced as to allow some of liquid 1 to form. Now at 40° the surface-tension is 67.56 dynes per centim., and in the body-water the amount of 1 per gramme is .716, and the value of dp_1/df at 40° is .000133, and therefore the tension per square centim. required to convert this amount of 1 into trihydrol will be .716/.000133 or 5380 atmos. Therefore the thickness of the surface-film (defined below) is

$$67.56/538 \times 10^7 = 12.6 \times 10^{-9} \text{ centim.}$$

Now Kelvin's estimate of the order of magnitude of ordinary molecular diameters is 2×10^{-9} centim., so that our surface-film would be only a few molecules thick. This agrees with what I have suggested as to the thickness of the surface-film according to the law of the inverse fourth power for molecular attraction. Of course with such a law of force it is impossible that there can be any natural boundary between surface-film and body of fluid, and it is obvious that the tension must be greatest in the first layer of molecules on the surface; in the tenth layer we can imagine the attractions of the eleventh to the eighteenth equilibrating those of the first nine, and the dissymmetry causing tension in our tenth layer is only that due to a mass which begins at nine times the molecular diameter away; the effect of this must be very small compared to the effect of dissymmetry in the condition of the first layer. The thickness of the surface-film D can be most rationally defined as twice the distance of the centre of tension from the surface, in symbols

$$D \int f dl = 2 \int f l dl,$$

where f is tension per unit area at depth l from the surface.

The average tension per square centim. of the film $\bar{f} = \alpha/D$. Above we have found $\bar{f} = 5380$ atmos and

$$D = 12.6 \times 10^{-9} \text{ centim.}$$

We can now calculate p_1 in equation (21), that is the amount of 1 in one gramme of the surface-film. For if we divide the surface-tensions of water at different temperatures by 12.6×10^{-9} , we get the average tensions per unit area in the surface-film as given in the table below. But if we divide the values of p_1 , derived from those of p_2 in Table I., by the values of dp_2/df at the same temperatures from Table VII., we get the tension required to convert all of 1 in the body of the water into trihydrol in the surface-film. The difference between the former tension and the latter, expressed as a fraction of the latter, gives that fraction of p_1 which has not been converted into trihydrol, so that if we multiply this fraction by p_1 for the body of the liquid, we get p_1 for the surface-film as required in equation (21), and as given in the next table along with the derived values of α_1 .

TABLE X.

t	60°	80°	100°
a	64.25	60.77	57.11 dynes
$p_1 \div dp_1/df$	6210	7160	8420 atmos
\bar{f}	5120	4840	4550 atmos
$10^9 p_1$ in surface...	131	248	360
α_1	61.28	57.48	53.48 dynes
$\alpha_1(18/\rho_1)^{\frac{2}{3}}$	429.3	397.6	365.2
$\alpha_1(36/\rho_1)^{\frac{2}{3}}$	681.4	631.0	579.6

The values of $d\alpha_1(18/\rho_1)^{\frac{2}{3}}/dt$ between 60° and 80° and between 80° and 100° are 1.585 and 1.62, mean 1.60; while for $d\alpha_1(36/\rho_1)^{\frac{2}{3}}/dt$ the values are 2.52 and 2.57, mean 2.54. These are about equally different from 2.121 for an average liquid; but we can more satisfactorily test whether 18 or 36 is the molecular mass of our ingredient 1 by assuming that the critical temperature of water 368° C. is that of 1, and therefore $\alpha_1(18/\rho_1)^{\frac{2}{3}}$ and $\alpha_1(36/\rho_1)^{\frac{2}{3}}$ must both vanish at about 368°; so that on dividing their values tabulated above by 308, 288, and 268 respectively, we should get much more reliable values of the appropriate coefficients. In this way for $\alpha_1(36/\rho_1)^{\frac{2}{3}}$ we get the temperature-coefficients 2.21, 2.19, and 2.16, mean 2.19, whereas the mean for the similar co-

efficient of $\alpha_1(18/\rho_2)^{\frac{2}{3}}$ is 1.38. This, then, is decisive, and furnishes our proof that the liquid 1 is dihydrol.

The exceptional properties of the surface-tension of solutions have been discussed in "Molecular Force and the Surface-tension of Solutions" (Phil. Mag. [5] xl.), and it is now evident that they must be largely due to the difference between the surface-layer and the body of water, and to a possible action of the solute in dissociating some of the trihydrol. The solubility of substances in trihydrol may be different from that in water. A re-examination of the surface-tension of solutions would be full of interest.

5. *Latent Heat of Fusion, Specific Heat and Latent Heat of Evaporation.*

According to what precedes, ice is pure trihydrol. The crystallization of water in the hexagonal system is strong confirmation of this; throughout the enormous variety of forms of ice-flowers the angle of 60° is the dominant factor, and in the theory of halos the ice-crystals of the higher atmosphere appear as necessarily hexagonal prisms. All this points strongly to a decided three-directional symmetry in the molecule of ice to which we shall return in section 8.

Meanwhile we must regard the latent heat of fusion of ice as no ordinary physical latent heat of fusion, for the melting of ice is accompanied by the conversion of .625 of its trihydrol into dihydrol; the latent heat of fusion must be mainly a chemical latent heat of dissociation. It is evident that this must be so, because ice in melting contracts by one-ninth; and if there were no dissociation involved ought to show a latent cold and not a latent heat of fusion. We can calculate what the true physical heat of fusion of solid trihydrol into liquid trihydrol ought to be approximately. In section 3 we took the virial constant for dihydrol to be 1852×10^7 with the dyne as unit of force; and according to the laws of molecular force the value for trihydrol must be nearly the same, as we shall see it to be in a subsequent calculation in this section. If ρ_2' and ρ_2 are the densities of solid and liquid trihydrol at 0° , then its true heat of fusion in ergs should be $l(\rho_2' - \rho_2)$, nearly. But $\rho_2' - \rho_2$ has been taken as .0366, and therefore the true heat of fusion in calories of trihydrol expanding on fusion would be $1852 \times 10 \times .0366/42 = 16$ calories. The greater part then of the 80 calories that go to the fusion of a gramme of ice must be used to dissociate .625 gramme of trihydrol into dihydrol and dissolve the remaining .375 gramme in .625 gramme of dihydrol.

Before going further we must consider the specific heat of water. In this property water again shows its very exceptional character; not only is the specific heat much larger than would be expected by analogy, but it is remarkably nearly constant over a large range of temperature. Evidently we have to do, not with a true physical specific heat, but with a very complicated thermal phenomenon involving dissociation. To unravel this we must make estimates of the specific heats of trihydrol and dihydrol. According to Kopp's rule the molecular specific heat of H_2O ought to be made up of 2.3×2 for the hydrogen, and 4 for the oxygen, that is 8.6; and therefore the specific heat ought to be $8.6/18 = .48$, which is near to the .504 for ice, but not to the 1.0 for water. According to Kopp's rule the specific heat of trihydrol ought also to be .48, unless some provision has to be made for the binding of three H_2O molecules into one, although all analogy indicates that it would be slight. Thus ice regarded as a polymeric form of H_2O uncomplicated by dissociation has a latent heat in accordance with Kopp's rule, and by contrast the large specific heat of water appears to be due to consumption of heat in causing dissociation. On examining the available data I find that substances on melting show an increase of specific heat varying from 20 to 50 per cent., with an average of about 25; and therefore we should expect pure liquid trihydrol at 0° to have a specific heat about .625. Now we know from Regnault's determinations that even up to 190° the specific heat of water increases but little; and we therefore conclude that at 200° , when most of the trihydrol has been dissociated and the dissociation heat is of small account, the specific heat of the tolerably pure dihydrol is 1.0. As the usual rate of variation of the specific heat of liquids is about .1 per cent. per degree, we may infer that pure dihydrol at 0 would have a specific heat about .83. This result seems to involve a large violation of Kopp's rule, according to which polymeric forms of H_2O ought to have a specific heat near .48. But the great difference in the densities of trihydrol and dihydrol at 0 makes it probable that there is a decided difference in their specific heats at 0° . As the best estimates that we can make at present, let us write for the specific heats

$$c_1 = .6(1 + .001t), \quad (23)$$

$$c_2 = .8(1 + .001t). \quad (24)$$

In the heating of a gramme of water we have to supply heat to raise the temperature of p_1 parts of dihydrol and of p_2 parts of trihydrol, and also heat to dissociate some trihydrol

into dihydrol, and also the heat to effect the solution of the dissociated trihydrol. Let h be the heat absorbed when p_1 gramme of dihydrol is mixed with $p_2 = 1 - p_1$ gramme of liquid trihydrol, and D the heat absorbed in dissociating a gramme of trihydrol into dihydrol, then for the heat dQ to raise the temperature of a gramme of water by dt we have

$$dQ = (p_1 c_1 + p_2 c_2) dt + (D + dh/dp_2) dp_2 ;$$

$$\therefore c = \frac{dQ}{dt} = p_1 c_1 + p_2 c_2 + (D + dh/dp_2) \frac{dp_2}{dt} . . . (25)$$

Now c the specific heat of water can be taken as constant at 1.0, while c_1 and c_2 are known from (23), (24), with dp_2/dt from (7); so that the last equation furnishes us with values of $D + dh/dp_2$, as given in the next table, where they are compared with those of $78 + 3290(.425 - p_2)^2$ given in the last row.

TABLE XI.

$t \dots$	0°	20°	40°	60°	80°	100°	120°	140°
	86	114	142	172	200	223	241	255
	86	114	143	173	198	220	240	258

It appears from this that

$$-D - \frac{dh}{dp_2} = 78 + 3290(.425 - p_2)^2 ; . . . (26)$$

$$\therefore -D p_2 - h = 78 p_2 - 3290(.425 - p_2)^3 / 3 + C ;$$

and as $h = 0$ when $p_2 = 0$,

$$C = 84.2.$$

Then at 0° with $p_2 = .375$ we have

$$-.375D - h = 113 ;$$

and from the latent heat of fusion of ice we have

$$-.625D + h = 64 ;$$

$$\therefore D = -177, (27)$$

$$-h = -99 p_2 - 3290(.425 - p_2)^3 / 3 + 84.2 . . . (28)$$

The negative sign of D is the result of dp_2 in (25) being negative; 177 calories have to be given per gramme of trihydrol to change it to dihydrol. This (28) then is the expression for the law of the evolution of heat when liquid trihydrol is dissolved in dihydrol up to a concentration of .425 trihydrol per gramme.

As water consists mostly of dihydrol while steam is hydrol, it follows that the latent heat of evaporation of water is not

a true physical latent heat of evaporation, but includes the heat of dissociation. We proceed to calculate the heat of dissociation of dihydrol into hydrol and the true latent heat of dihydrol.

If we take 368 as the critical temperature of dihydrol, then at $\frac{2}{3}$ of the absolute critical temperature, that is at 155° C., the gramme-molecular surface-tension of dihydrol must be about $2\cdot121(368-155)$ or 452. Now according to the fifth method of finding the virial constant l for a substance ("Laws of Molecular Force," *Phil. Mag.* [5] xxxv. p. 258),

$$l = c\alpha v^{\frac{5}{3}}/M^{\frac{1}{3}},$$

where $c = 1209$ when l is measured in terms of the megadyne and α of the dyne; for dihydrol

$$l = 1209 \times 452 \times v/M,$$

$$v = 1/1\cdot08942(1 - 0\cdot0009 \times 155), \quad M = 36;$$

$$\therefore l = 16192.$$

The equation of the third method of finding l (*ibid.*, p. 245) is

$$l/v = 66\cdot5\lambda - 101T_b/M, \quad (29)$$

where T_b is the boiling-point (absolute), λ the latent heat of evaporation, and v the volume of a gramme of the liquid at the boiling-point. Now λ does not vary rapidly with the temperature, so we shall make but little error in taking 100° as the boiling-point of dihydrol; then

$$T_b = 373, \quad M = 36, \quad v = 1\cdot009;$$

$$\therefore \lambda = 257 \text{ calories.} \quad (30)$$

But the latent heat of water at 100° is 537, and is the heat of evaporation of a solution of $\cdot217$ gramme of trihydrol in $\cdot783$ of dihydrol, and of the dissociation of both into hydrol.

Now the removal from solution of the $\cdot217$ gramme of trihydrol would require by (28) $52\cdot8$ calories, and its dissociation into dihydrol by (27) $38\cdot4$; so that to convert a gramme of water at 100° into pure dihydrol requires altogether $91\cdot2$; and therefore for the evaporation of a gramme of dihydrol and its dissociation into hydrol $537 - 91$ calories are required; and therefore the heat of dissociation of a gramme of dihydrol into hydrol is $446 - 257$ or 189 calories.

We can partly check this result by the following reasoning. To dissociate a gramme of trihydrol into hydrol *via*

dihydrol will require $177 + 189$ or 366 calories, and for the solid trihydrol 382 ; the usual so-called latent heat of evaporation of ice is about 660 ; and thus the latent heat of evaporation of liquid trihydrol, if evaporated without dissociation, would be 278 calories; of solid trihydrol 294 .

The latent heat of evaporation of trihydrol at its boiling-point can be estimated in exactly the same way as that of dihydrol. As $\alpha_2(54/\rho_2)^{\frac{2}{3}}$ at 0° is 1141 , and diminishes $2\cdot121$ per degree till it is zero at the critical temperature, the critical temperature of trihydrol is 538° C.; therefore at $\frac{2}{3}$ of the absolute critical temperature $\alpha_2(54/\rho_2)^{\frac{2}{3}}$ is $271 \times 2\cdot121$, and

$$l = 1209 \times 271 \times 2\cdot121 \times v_2/54,$$

$$v_2 = 1\cdot88(1 - 0\cdot0002 \times 267);$$

$$\therefore l = 15,440, \text{ with } 10^6 \text{ dynes as unit.}$$

Taking the absolute boiling-point at $\frac{2}{3}$ of the absolute critical temperature, as it nearly is for most liquids, we find for λ by (29) at 267° C. the value 209 . This is at 267° , while at 0° on our former reasoning the value found was 278 , and these two are in reasonable agreement, implying about 250 at 100° C.

The main results of this section can be expressed in the two thermochemical equations

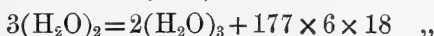
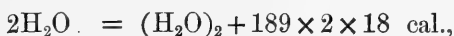

6. The Viscosity of Water.

In its viscosity water shows one of its most characteristic peculiarities, namely, the decrease of its viscosity with increase of pressure, discovered by Röntgen, and discussed by him in his theory of the constitution of water. We can make this phenomenon the subject of quantitative study, thanks to the refined measurements made by R. Cohen (*Wied. Ann.* xlv.). But it will be best to take the variation with temperature first. At 0° trihydrol is below its true physical melting-point, and accordingly we should expect the viscosity of the liquid trihydrol to be very great; on the other hand, dihydrol at 0 is probably far above its melting-point, and must have a relatively small viscosity; therefore the viscosity of water at temperatures near 0° must be mainly that of the trihydrol in it, the dihydrol gradually becoming of more importance as the temperature rises.

It has been found that the viscosity η of mixtures is not accurately expressible by a mixture-by-weight formula such as $\eta = p_1\eta_1 + p_2\eta_2$, but Thorpe and Rodger (Journ. Chem. Soc. lxxi.) find the following type more successful.

$$\eta = (\eta_1 p_1 v_1 + \eta_2 p_2 v_2) / (p_1 v_1 + p_2 v_2), \quad \dots (31)$$

which may be written in the form

$$\eta v = \eta_1 p_1 v_1 + \eta_2 p_2 v_2. \quad \dots (32)$$

As to variation of viscosity of a pure liquid with temperature, it seems to me best to use the equation of Graetz (Wied. Ann. xxxiv.),

$$\eta = A(t_c - t) / (t - t_r), \quad \dots (33)$$

where t_c is the critical temperature and t_r is a temperature some tens of degrees below the solidifying-point. Then for water we write

$$\eta v = A_2 p_2 v_2 \frac{538 - t}{t + x} + A_1 p_1 v_1 \frac{368 - t}{t + 150}, \quad \dots (34)$$

assuming that dihydrol has t_r 150 below zero; because by analogy the solidifying-point of dihydrol must be low, and at any rate the second term on the right is of less importance than the first. Using the viscosities of water given by Hosking (Phil. Mag. [5] xlix.), we find

$$A_2 = \cdot 002344, \quad x = 33\cdot 1, \quad A_1 = \cdot 001222,$$

which give the comparison :—

TABLE XII.

t	0°	20°	40°	60°	80°	100°
$10^5 \eta_2 p_2 v_2$	1624	837	520	353	257	194
$10^5 \eta_1 p_1 v_1$	172	159	144	130	116	103
$10^5 \eta v$ calc.	1796	996	664	483	373	297
$10^5 \eta v$ exp.	1794	1011	662	480	370	297

The discrepancy at 20° illustrates the difficulty of getting mixture-formulae to represent the viscosity of mixtures.

As to the effect of pressure on the viscosity of our mixture, we can differentiate (32) with respect to pressure f ,

$$\begin{aligned} & p_1 v_1 \frac{d\eta_1}{df} + p_2 v_2 \frac{d\eta_2}{df} \\ &= v \frac{d\eta}{df} + \eta \frac{dv}{df} + (\eta_1 v_1 - \eta_2 v_2) \frac{dp_2}{df} - p_1 \eta_1 \frac{dv_1}{df} - p_2 \eta_2 \frac{dv_2}{df}. \quad (35) \end{aligned}$$

The terms on the right are now all known, as from Cohen's curves we can estimate with considerable accuracy $d\eta/\eta df$ at 0° when df is 200, 400, and 600 atmos respectively, namely $(305, 224, \text{ and } 192) \times 10^{-9}$, and the other data are contained in the previous sections. Thus in the three cases we get for the left side of (35) the values $(55, 56, \text{ and } 56) \times 10^{-7}$. The greater part of these values must be due to $p_2 v_2 d\eta_2/df$, so neglecting $p_1 v_1 d\eta_1/df$ we find

$$\frac{1}{\eta_2} \frac{d\eta_2}{df} = \cdot 00034; \dots \dots \dots (36)$$

that is to say, that an increase of pressure of 100 atmos causes the viscosity of trihydrol at 0° to increase by 3.4 per cent. For ethyl oxide and benzene at 20° , Warburg and Sachs (Wied. Ann. xx.) found a corresponding percentage increase of 7.3 and 9.3, and Cohen for turpentine found 15, and these are all more compressible liquids than trihydrol. In regard to viscosity, trihydrol behaves like a normal liquid, and the exceptional change of the viscosity of water under pressure is due to the dissociation caused by the pressure, which replaces some of the highly viscous trihydrol by the less viscous dihydrol. Cohen's curves show that at about 30° the viscosity of water must be almost independent of pressure up to 1000 atmos; at this temperature the normal effect and the dissociation effect neutralise one another.

The preceding treatment of water's viscosity shows that the viscosity of aqueous solutions must be highly complicated on account of the action of the solute in altering the proportions of trihydrol and dihydrol in the solution. It is known that the viscosity of some aqueous solutions of solids is less than that of water itself. The reason for this surprising old fact is now apparent; the solute converts enough of the viscous trihydrol into the less viscous dihydrol to more than compensate for the increase of viscosity which its own presence imparts.

7. Dielectric Capacity.

Of the dielectric capacity of water and ice we have already made some study in section 2, for electric fields alternating with the frequency of light, since n^2 stands for K , the dielectric capacity. But for K in more slowly alternating fields and in a steady field the experimental results are in apparent conflict. Thus Heerwagen (Wied. Ann. xlix.) and Drude (*ibid.* lix.) find a steady, almost linear diminution of $\sqrt{\epsilon}$

water with temperature from 0° to 80° ; while Thwing (*Zeitsch. f. Phys. Chem.* xiv.), with rapidly alternating oscillations (period not given), finds the capacity rise to a sharp maximum at 4° . In his measurements for different mixtures of alcohol and water at a fixed temperature, instead of a steady curve representing the variation of K with composition, he gets a curve containing cusps at points which correspond to the formulæ $C_2H_6O + 6H_2O$, $C_2H_6O + 3H_2O$, and $C_2H_6O + H_2O$; and similarly for mixtures of water with propyl alcohol, methyl alcohol, glycerine, and acetic acid, he gets cusps at points of definite molecular proportions. Drude (*Zeitsch. f. Phys. Chem.* xxiii.), on the contrary, gets a steady curve for K for water-alcohol mixtures running the same course as Thwing's with the cusps smoothed out. It looks, therefore, as if Thwing had used a period of vibration which was particularly sensitive to arrangements of electrons in regular order corresponding to the molecular proportions in his mixtures. His sharp cusp for water at 4° is indicated by the following excerpts from his data:—

Temp.	0°	2.2°	4°	6°	7°
K	79.46	80.84	85.2	80.84	79.4

Otherwise his observations for water make K run with temperature a course very similar to that found by Drude and Heerwagen. If his cusp for water has the same significance as his cusps for other mixtures, we should have to take it as implying for water at 4° the composition $(H_2O)_3 + 3(H_2O)_2$, that is, .333 trihydrol mixed with .667 dihydrol, while our formula (9) gives .363 with .637. An alteration in our somewhat arbitrarily chosen density of liquid trihydrol (.88) at 0° would change these proportions to .333 and .667; but until Thwing's remarkable observations have been confirmed by further special experiments, I should not feel quite warranted in making such changes in the constants of this paper as would make the composition of our standard mixture at 4° to be $(H_2O)_3 + 3(H_2O)_2$. That ice near 0° shows K of the order 78 when tested by electric oscillations of period about 10^{-1} to 10^{-2} second, and of the order 2 for periods of 10^{-6} and less, is a fact of prime importance in the relation of molecules to electrons. Dewar and Fleming's measurements of K at low temperatures bring out also the high promise of K for giving an insight into molecular architecture. But for the present the experimental data for water and ice hardly allow of more elaborate investigation than the above.

8. *The Melting of Ice as a Phenomenon of Dissociation, and the Higher Valency of Oxygen.*

The polymerization of hydrol, which we have been studying, is only a special case of a general tendency of oxides, both organic and metallic, and other oxygen-containing compounds, to polymerize (see L. Henry, "The Polymerization of the Metallic Oxides," *Phil. Mag.* [5] xx.). This tendency is best explained by assigning to oxygen a higher valency than the dyad which it usually shows. Evidence for the tetrad nature of oxygen has been submitted by Friedel, Heyes (*Phil. Mag.* [5] xxv.), and Brühl (*Ber. d. Deut. Chem. Gesel.* xxviii., xxx.). The tetrad valency may in reality be hexad sometimes; but on the principle of assigning the minimum valency that will explain the facts, we shall assume oxygen to be tetrad. The graphic formula for trihydrol then becomes that shown:—

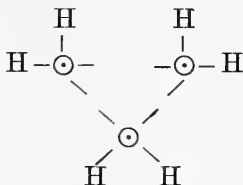

The centres of the three oxygen atoms determine a plane and a triangle in it, whose average shape must be equilateral. It is improbable that the hydrogen atoms lie in the same plane as the oxygen, but as their masses are small in comparison with those of the oxygen, the centre of mass of each H_2O group is near to the centre of the oxygen atom in it, and the equilateral triangle must be the dominant feature of the molecule of trihydrol. The hexagonal form of the ice crystals and the formula of trihydrol both demonstrate that the domain of a molecule of ice is an equilateral triangular prism. As this is, I believe, the first case in which a definite shape has been ascertained for a molecule, it would be interesting in connexion with it to investigate systematically the properties of crystalline ice in different directions.

For dihydrol, on the same principle, the graphic formula will be this:—

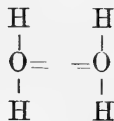

There is a strong probability that in water some of the

trihydrol is continually dissociating into dihydrol, and some of the dihydrol associating to trihydrol ; but the most striking dissociation of trihydrol into dihydrol is that which accompanies the melting of ice. Under a given pressure this occurs with remarkable definiteness at a corresponding temperature.

The thermodynamical discovery and explanation of the lowering of the melting-point of ice by pressure, though so justly famous in the history of the science of heat, give no clue to the mechanical or molecular cause of this remarkable phenomenon. In a solid body we assume the molecules so to hinder one another's motion, that each is kept vibrating within narrow limits round a certain point. With rise of temperature the mean distance between two neighbours increases, and when the distance increases to such an extent that the molecules can no longer hem one another in, they all start migrating, and the solid is said to melt. Now at the melting-point an increase of pressure, by forcing the molecules nearer to one another, ought to necessitate an increase of temperature to cause melting, for the increase of temperature would neutralize the effect of the increase of pressure. This is the molecular explanation for the usual fact that increase of pressure increases the melting temperature. But in the exceptional case of ice, although it expands with heat as long as it is ice, and shrinks under pressure, yet though pressure brings the molecules nearer together, they escape by melting at a lower instead of a higher temperature. Moreover ice at 0° is a solid of very considerable rigidity, though it is on the very verge of melting. Its actual rigidity has not been measured, but as it has a Young's modulus between 20,000 and 90,000 (probably 70,000) kgms. weight per sq. cm., that of glass at 15° being 500,000, and of silver 760,000, it is evident that ice on the verge of melting still enjoys a remarkable degree of rigidity. The melting of ice is of an entirely different character from that of an ordinary physical melting. We have proved it to be accompanied by considerable dissociation. A simple conception of the dynamical cause of this dissociation can be obtained by following the lines of investigation of "A Kinetic Theory of Solids" and "Further Studies on Molecular Force" (Phil. Mag. [5] xxxii. & xxxix.). In these papers it is assumed that in solid compounds atomic motions are more important than molecular, because of Joule's and Kopp's law that each atom contributes a definite atomic heat. The atoms in the solid are still held by the chemical forces in their proper arrangement to form the molecule, but the molecules are so

close to one another that the atoms of adjacent molecules jostle one another almost as freely as do the atoms within a single molecule. In the case of ice, by far the greater part of its heat-energy consists of the kinetic energy of the hydrogen and oxygen atoms, almost as if ice were a mechanical mixture of these, except that each oxygen atom and its two combined atoms of hydrogen influence one another's relative motions by the action of the chemical forces. In the same way in the molecule of trihydrol $(\text{H}_2\text{O})_3$, the chemical forces must be regarded chiefly as controlling the H_2O molecules into groups of three, thereby regulating their arrangement, but not seriously affecting the motion of the constituent atoms in any other way. Let us name the oxygen atoms of $(\text{H}_2\text{O})_3$ A, B, C. Then for each there is some point where the attractions of all other atoms for it are in equilibrium; call these for the three oxygen atoms α, β, γ , forming an equilateral triangle. Then on the average A will vibrate through α in a direction perpendicular to $\beta\gamma$ with an amplitude w . The largest deformation of the equilateral triangle commonly occurring will be when A is displaced w outwards and B and C w inwards, or what this configuration changes to in half a period of its vibration when B and C are displaced w outwards and A w inwards. Let the side of the triangle be denoted by D, then the deformation of the triangle would be conveniently measured by w/D . When the deformation reaches a certain value, the chemical equilibrium of the three oxygen atoms becomes unstable, the bonds AB AC may be said to break under the breaking-strain, or the electrons which form the chemical bonds swing round so that B and C are united by double bonds, and A is free to assist in upsetting the equilibrium of a neighbour molecule of $(\text{H}_2\text{O})_3$, and so the process goes on.

Now D and w must both be regarded as functions of f the pressure and T the absolute temperature. Now the fact that to melt ice at constant pressure we have to warm it up to the melting-point, shows that w/D increases with T, as indeed we should expect to be the case. Again, from thermodynamics and experiment we know that if the pressure on ice is increased by 1 atmo, the melting-point falls by $\cdot 0075$ degree, and therefore w/D at constant temperature diminishes with increasing pressure. Both properties of w/D would be accounted for by considering D relatively more affected by pressure and less by temperature than w . The dissociation of some of the trihydrol in water into dihydrol by increase both of temperature and pressure is explainable by these same properties of w and D.

But these principles alone would lead us to expect that the melting of ice should be preceded by a stage of general softening, as with sealing-wax, on account of the occurrence of isolated cases of instability before all the molecules got to the unstable point. The sharpness with which the melting of ice occurs seems to me to indicate that we have to do with a phenomenon of molecular resonance. If the collisional forces were removed, and also the intermolecular, then under the chemical forces our triangle ABC would have a natural period of vibration round the equilateral shape of equilibrium. If the period of vibration of each of the atoms A, B, and C, on account of other attractions and collisions, becomes the same as this natural period, then by resonance small deformations of ABC will be worked up to large enough ones to attain the stage of instability. When some of the ice dissociates into dihydrol, this dissolves the remainder, altering for it both w/D and the period of collisions, thus enabling it to exist.

The mechanical explanation of the melting of ice as a process of dissociation consists then of two parts: one accounting for the occurrence of a position of instability, the other accounting for the sharpness with which all the molecules attain this position simultaneously. The complete molecular or mechanical theory of the lowering of the melting-point of ice by pressure must then take account of the change not only of the deformation w/D with temperature and pressure, but also of the resonance.

If the surmise is correct that molecular resonance plays an important part in the melting of ice, then the dissociation of trihydrol presents an interesting similarity to that of rarefied ozone, to which I have drawn attention ("The Spontaneous Change of Ozone into Oxygen, and a Remarkable Type of Dissociation," *Phil. Mag.* [5] xliii.). As rarefied ozone is gradually compressed, it begins at a pressure of .14 mm. of mercury to dissociate, because the average frequency of collisions between the molecules is the same as some natural frequency of vibration of the constituent atoms, or a simple multiple of it. This frequency must be of about the order 10^8 per second. We can estimate the order of the frequency which is destructive to molecules of trihydrol in the following way:—From the known so-called molecular volumes of hydrogen and oxygen (really their molecular domains) we can infer that the oxygen atom occupies about $\frac{1}{3}$ of the space belonging to H_2O . Now the linear coefficient of expansion of ice being $\cdot000157/3$, the linear interspaces between the groups H_2O of ice at 0° centigrade

(see "A Kinetic Theory of Solids") will be of the order $\cdot 000052 \times 273 \times 7$ times the mean diameter of the H_2O group, but as the H atoms move four times as fast as the O atoms, and there are 2 of them to 1 of O of about the same size, we may give the oxygen atoms an amplitude $\frac{1}{3}$ of the linear interspace allotted to each H_2O . The velocity of the O atom is of the order 46,000 cm. per sec., and the diameter of the H_2O group of the order 2×10^{-9} cm., so the required frequency is of the order $46 \times 9 \times 10^{18} \div (2 \times 2 \times 7 \times 52 \times 273)$, or 10^{15} per sec. As the frequency for the most luminous part of the solar spectrum is of the order 5×10^{14} , we find that our calculated destructive frequency of vibration for the molecules of trihydrol must be about the same as that of some part of the measured solar spectrum, in which the frequency ranges from less than 10^{13} to about 10^{15} per sec. If resonance plays an important part in the melting of ice, then ice ought to absorb powerfully radiation of the right period, and to show anomalous dispersion in neighbouring parts of the spectrum. In the visible spectrum, ice shows no anomalous dispersion. The absorption spectrum of ice in the infra-red and ultra-violet regions would be worth study.

The laws of the dissociation of dihydrol (H_2O)₂ into hydrol, H_2O , could be worked out by an examination of the behaviour of the vapour of water at pressures and temperatures up to and beyond the critical. It is probable that in ordinary water there is a little dissociation of dihydrol into hydrol. The question arises as to whether (H_2O)₂ can be split into positive and negative ions H_2O , the difference between which and the molecules of water-vapour would be the same as the difference between the zinc ion and the atom of zinc-vapour. The theory of electric conduction in aqueous solutions may be considerably affected by the possible participation of H_2O ions.

The difference between the H_2O molecule and the H_2O ion could be expressed by saying that each negative H_2O ion contained two negative electrons, whereas the molecule H_2O contains a negative and a positive electron that equilibrate one another within the molecule. The formation of (H_2O)₂ consists then in two H_2O molecules exchanging electrons, so that one has two negative and the other two positive, which equilibrate as long as the (H_2O)₂ lasts. In (H_2O)₃ each H_2O has a positive and a negative electron, but these, instead of equilibrating one another within the group, equilibrate with those of the other groups so as to hold the (H_2O)₃ together.

Mendeléeff, Crompton, and S. U. Pickering have shown by

their elaborate examination of the delicate *nuances* in the physical properties of watery mixtures, that the alcohols, sulphuric acid, amines, and other compounds combine molecularly with water to form such bodies as $C_2H_6O + 12H_2O$, $3C_2H_6O + H_2O$, $H_2SO_4 + H_2O$, $H_2SO_4 + 6H_2O$, and the like. These must be further examples of the tendency to polymerization due to the tetrad or higher valency of oxygen. In water of crystallization the same principle is at work. The methods of this paper can be applied to other associating liquids.

9. Summary of Results.

Ordinary water-vapour being H_2O , which it is proposed to call internationally hydrol, ice is trihydrol $(H_2O)_3$, and water a mixture of trihydrol and dihydrol $(H_2O)_2$, the proportions of which are determined by equations (7) and (9) up to 100° and approximately to 200° . Probably at its critical temperature water is practically pure dihydrol. The latent heat of fusion of ice is not an ordinary physical latent heat of fusion, but is mostly a latent heat of dissociation of trihydrol into dihydrol, partly masked by heat of solution of trihydrol in

TABLE XIII.

	Density ρ at 0° .	Temp.-coeff. of density, k .	$\frac{n^2-1}{n^2+2} \cdot \frac{1}{\rho}$ at 0° .	Compressibility per atmo at 0° .
Dihydrol ...	1.08942	.0009	.20434	.000016
Trihydrol88	.0002	.20968	.000010 ?
	Surface- tension at 0° .	Critical temperature.	Specific heat at 0° .	Virial Constant.
Dihydrol ...	78.3	368 C.	.8	16200×10^6
Trihydrol ...	73.32	538 C.	.6	15400×10^6
	Latent heat of fusion.	Latent heat of evaporation at 100° .	Viscosity at 0° .	Pressure-coeff. of viscosity per atmo.
Dihydrol	257 cal.	.0030	...
Trihydrol ...	16 cal.	250 (near)	.0381	.00034

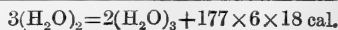
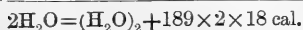

dihydrol. The latent heat of evaporation of water includes also the heat of dissociation of the dihydrol and trihydrol of water into the hydrol of steam. The specific heat of water is not an ordinary specific heat but includes a certain amount of heat of dissociation, Pressure dissociates trihydrol at rates given in Table VII.

In Table XIII. are the physical constants of the two ingredients of water given in C.G.S. units unless it is otherwise stated.

These results have mostly been obtained by application of the mixture formula on the assumption that no shrinkage or analogous change of properties takes place, and several of them depend on .88 the density of liquid trihydrol at 0°, which has been merely estimated by analogy from the density of ice.

Melbourne, July 1900.

XLVII. *Experiments to Determine whether a Liquid when electrified loses any portion of its charge by Evaporation.* By W. CRAIG HENDERSON, M.A., B.Sc., Trinity College Cambridge, late 1851 Exhibition Science Scholar*.

THE question whether the vapour rising from the surface of an electrified liquid is itself electrified or not, has received considerable attention during recent years; but unfortunately the various physicists who have made experiments on the subject have not all arrived at the same conclusion.

On the one hand a negative answer is given to the question by Blake †, by Schwalbe ‡, and by Sohnecke §; while on the other hand Exner || and Pellat ¶ both answer the question in the affirmative. Each of these two physicists proceeds to apply this conclusion from his experiments to the case of evaporation of water from the earth's surface, and seeks thus to account partly for the electrification of the atmosphere. On consideration of Pellat's paper it seemed to me not inadvisable to make still one more investigation of the problem, and this idea was approved of by Professor J. J. Thomson.

In the experiments described below I have kept in view Pellat's application to the case of atmospheric electricity, and have therefore in the first place followed him in using only

* Communicated by Prof. J. J. Thomson, F.R.S.

† Blake, *Wied. Ann.* vol. xix. 1883, p. 518.

‡ Schwalbe, *Ibid.* vol. lviii. 1896, p. 500.

§ Sohnecke, *Ibid.* vol. xxxiv. 1888, p. 925.

|| Exner, *Sitzungsber. der Kaiserl. Akad. der Wissen. zu Wien*, xciii. p. 222 (1886).

¶ Pellat, *Journ. de Phys.* 1899, May, p. 253.

water, negatively charged, as the liquid to be evaporated, and in making all the experiments at the ordinary temperature of the room. Following these experiments I have made further experiments with water heated up to the boiling-point, thus ensuring rapid evaporation; and, lastly, experiments were made in which ether was used as the liquid to be evaporated.

It may be stated here that the result of my experiments is in opposition to that of Pellat's, as they show no loss of charge from the liquid by evaporation.

1. *Evaporation of Water at Ordinary Temperature of Room.*

The method of experiment used by Pellat was to insulate a shallow vessel on a block of paraffin, connect it to the insulated quadrants of an electrometer, charge it to a known potential noting the deflexion on the electrometer scale, and then observe the leakage of this charge during a certain time. The experiment was then repeated with the vessel full of water. In this way Pellat found that the leakage was somewhat greater when the vessel was full of water than when it was empty. The results of four sets of experiments are given and are as follows:—

	Potential in Volts.	Time between beginning and end of experimt.	Electrometer Deflexion		Excess of (a) over (b).
			(a) with Water in vessel.	(b) without Water in vessel.	
I. ...	155	h. m. 1 25	301·9	278·2	23·7
II. ...	116	1 39½	145·0	135·5	9·5
III. ...	116	1 44½	172·8	159·3	13·5
IV. ...	116	1 45	182·9	170·4	12·5

It will be seen that in these experiments the excess of leakage when water was present over that when there was no water is in no case more than 8·5 per cent. of the leakage observed without any water in the vessel. The presence of so large* a leakage when the vessel is empty would seem to introduce a possible ambiguity into the result when water is

* The percentage of the loss of charge *without* water in the vessel to the total charge given to the system, as denoted by the deflexion on the electrometer scale, is as follows:—

In Expt.	I. above,	56·8	per cent.
" "	II. "	58·2	" "
" "	III. "	70·5	" "
" "	IV. "	69·3	" "

present in the vessel ; and therefore in the experiments now to be described, a method was adopted which should not be open to this objection.

The method of experiment and the apparatus employed can be most easily described by reference to the annexed diagram. A cylindrical metal box, A, had a platform of metal, B, inside it, insulated from the bottom of the box by ebonite plugs. The lid of the box had a similar platform, a disk of metal, C, underneath it, similarly insulated from the lid. A wire passed from B through a hole in the side of the box to the insulated quadrants of an electrometer, and had that

Fig. 1.

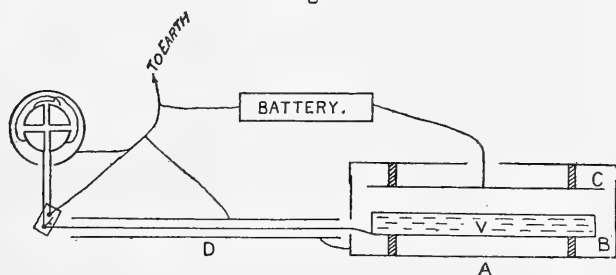

portion of its length which was outside the box surrounded by a metal guard-tube D. The vessel, V, containing the water was of lead, 8 cms. in diameter and 1.5 cms. in depth, and was placed on the platform B. The distance between C and the surface of the water was 2 cms. The disk C was connected by a wire passing through a hole in the lid to one terminal of a battery of storage-cells, while the other terminal of the battery was put to earth by connecting it to a gas-pipe. The uninsulated quadrants and sheath of the electrometer, the box A, and the guard-tube D, were connected by a wire with one another and with the gas-pipe.

The experiments are performed as follows:—The water-vessel resting on B is put to earth by joining the two pairs of quadrants. Thus the box A and the water-vessel are at the same potential. Next C is connected to the positive terminal of the storage-cells (a sufficient number being used to give the desired potential), and the negative terminal put to earth. Then the connexion between the two pairs of quadrants is broken, so that the water now has a negative charge ; but it is at the same potential as the box from which it is insulated, so that there should be no tendency to leak down the ebonite supports. If the water in V, however, loses some of its charge by evaporation, this equality of potential will no

longer exist, and a *positive* deflexion on the electrometer scale will be obtained.

Consider what would be the effect of the atmosphere in the box becoming saturated with water-vapour. In such a state evaporation still continues, only there is as much condensation as evaporation. Thus if the evaporating particles carry a charge they should be driven by the electric field over to the plate C and there discharged, while the particles condensing on the water-surface do not bring a charge with them. But probably around these charged particles a rapid condensation would take place, and some of them would be returned to the water-vessel carrying their charge with them. In order, therefore, to obtain the maximum effect the holes in the side and lid of the box were large enough to prevent saturation of the atmosphere within.

To eliminate external effects experiments were made with the vessel V empty as well as with V full of water. The following are the results of four experiments :—

	Potential of C.	Deflexion from zero of Electrometer.
I. With water in V	+ 80 volts	0 in 57 minutes
II. " " "	+ 80 "	- 1 " 55 "
III. (a) Without water in V ...	+143 "	+10 " 60 "
(b) With " " " ...	+143 "	+ 9 " 60 "

In III. (a) the potential of the cells fell through 2 volts in the hour during which readings were taken; while in III. (b) it fell through 3 volts. It remained, therefore, to find the effect on the deflexion of this fall of potential. To determine this V was put to earth by joining the pairs of quadrants, C was then raised to a known potential, and V then insulated. The wire from C to the cells was then disconnected from the cells and joined to the case A, and the deflexion on the electrometer noted. The following readings were taken :—

With +4 volts on C, when C was put to earth, deflexion = -4 scale-divisions.
 " +20 " " " " " " " " = -20 "
 " +40 " " " " " " " " = -40 "

The inductive effect, therefore, on V of a fall of potential of C is to give a negative deflexion on the electrometer scale of 1 scale-division per volt fall of potential. To the deflexion in experiment III. (a) we must therefore add 2, and to that in III. (b) we must add 3. We thus get a deflexion of 12 in each case.

We have seen that a loss or diminution of the negative charge on the water in V gives a positive deflexion on the electrometer. But the positive deflexion obtained in the first of these two experiments, with V empty, has not been increased in the repeated experiment with V full of water. And in the experiments at a lower potential with water in V, although V was perfectly insulated from the enclosing box, the two remained at the same potential throughout the duration of the experiment. We may therefore conclude that there has been no loss of charge from the water by evaporation of sufficient amount to be detected by this method of experiment.

We have, therefore, next to determine the minimum loss of charge which could have been detected. To do this we require to know the capacity of the system consisting of quadrants, wire, and vessel V. By comparison with a condenser consisting of two coaxial cylinders of known dimensions this was found to be 83 electrostatic units.

Take $\frac{1}{5}$ division per minute as the minimum deflexion which could be relied upon. A Clark cell gave a deflexion of 31 divisions; that is 1 division is equivalent to a potential-difference of $1.434/31$ of a volt. Let q denote the corresponding loss of charge from V per second per unit area. Then, since radius of V is 4 cms.,

$$q = \frac{1}{60} \times \frac{1}{5} \times \frac{1.434}{31} \times \frac{1}{300} \times 83 \times \frac{1}{\pi(4)^2},$$

$$= 0.84 \times 10^{-6} \text{ electrostatic units.}$$

Thus a loss of charge from V of 0.86×10^{-6} of an electrostatic unit per second per square centimetre could have been detected.

2. Evaporation of Water at High Temperature.

Arrangements were now made to experiment with water heated up nearly to the boiling-point. Readings were not taken when the water was actually boiling as electrical effects due to bubbling might then be introduced, and also because it has already been found* that the steam rising from boiling water charged with electricity carries off none of that charge.

For these new experiments a slight change in the apparatus of fig. 1 had to be made. There the insulating supports of the plate C and of the platform B are *inside* the case A; but

* Beattie, *Phil. Mag.* xlviii. 1899, p. 97.

as the warm vapour might condense on these supports and so spoil the insulation it was necessary to have all insulators *outside* the case A containing the water-vessel. The arrangement made is shown in fig. 2.

The metal disk B supporting the water-vessel V was fixed

Fig 2.

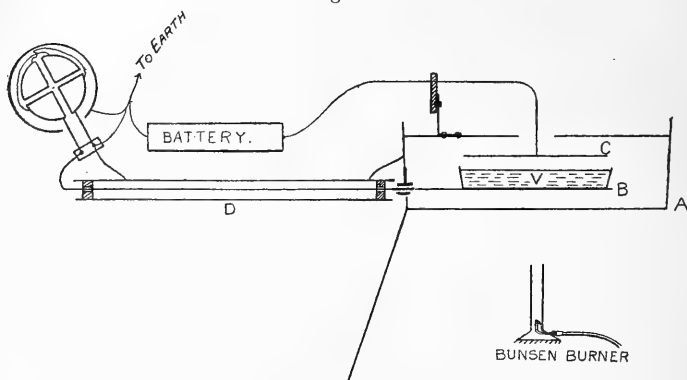

at the end of a stout bar of brass (of breadth 1 cm.) which passed into the case A, of galvanized iron, by a narrow slot in the side. Outside the case A this bar passed along the axis of a metal tube D, fixed in clamps, and was supported by D, and insulated from it, by plugs of sulphur at the ends. These sulphur plugs had cork centres through which the bar passed, in order to prevent melting of the sulphur by heat conducted along the rod. The other end of this bar was connected as before by means of a mercury cup to the insulated quadrants of the electrometer. A piece of ebonite was fixed above the lid of the case A at the end of a short brass angle-piece rivetted to the lid, and through this ebonite passed a stout wire turning down through the hole in the lid, and bearing the disk C at its end inside the case. All other connexions were as before. The water-vessel now used was of tinned iron and of the same radius as the lead vessel used in fig. 1. A large Bunsen-burner was placed under the case A, and a metal screen was attached to the case to prevent as much as possible any of the hot gases from reaching the rod attached to the electrometer.

In actual experiments it was found that as long as the Bunsen flame was present there was always an electrical effect, due to this flame, shown on the electrometer. As soon as the flame was extinguished this effect ceased. Readings were therefore taken while the liquid was cooling. In

order, however, to show the effect of the flame a double set of readings is given in experiment (1) in the table below; the first set was taken while the flame was present and the water was being heated up, the second set was taken after the flame had been extinguished and the water left to cool. Between these two sets of readings the quadrants of the electrometer were of course connected together so as to start the second set from the zero-point of the scale. It will be seen that in both sets the deflexion obtained with water in the vessel is practically the same as that obtained with the vessel empty. In other experiments, however, this first set of readings was omitted, as so large a deflexion due to an outside cause might give rise to ambiguity.

In some experiments, instead of heating up the water in the case, the water was boiled apart over a separate Bunsen flame, while the case with its lid in position was heated up by its own Bunsen flame till a temperature of over 100° C. was obtained inside the case. The boiling water was then introduced quickly, the lid replaced and connexion made with the battery, and then when the flame was extinguished a set of readings could be commenced.

The following table gives the results of three experiments. The double set of readings in experiment (1) has been already explained.

No. of Experiment.	Potential of C.	Deflexion from zero of Electrometer.		
			While heating.	While cooling.
(1)	+144 volts.	Without Water.	+107 divs. in 40 m.	+13 divs. in 40 m.
		With do.	+111 ,, ,, 40 m.	+13 ,, ,, 40 m.
(2)	+150 volts.	Without Water.		+26 divs. in 50 m.
		With do.		+24 ,, ,, 50 m.
(3)	+150 volts.	Without Water.		+23 divs. in 50 m.
		With do.		+22 ,, ,, 50 m.

In these experiments, omitting the readings while heating in experiment (1), it will be seen that in no case was the positive deflexion greater when water was present in V than when V was empty; but it should be greater if the vapour

carried off any of the negative charge. The conclusion, therefore, again is that there has been no loss of charge by evaporation such as could be detected by this apparatus. We shall consider later what that amount would be.

A further series of experiments was made corresponding to those just described, but using *distilled* water and with the surface of the water carrying a positive instead of a negative charge. These, however, gave results in no way different from the above.

3. Evaporation of Ether.

To make still further tests on this subject, since those with water had given a different result from that obtained by Pellat, experiments were now made with ether as the evaporating liquid. A very rapid evaporation was thus obtained at the ordinary temperature of the room.

The apparatus used was that of fig. 2, and in the experiments made it was found that in the course of an hour, without any heat being applied to the case, the liquid, which at first filled the vessel V, had almost entirely evaporated away. The results of three experiments are given in the following table:—

		Potential of C.	Deflexion from zero of Electrometer.
(a)	Without Ether.	+146.5 volts.	+ 4 divs. in 60 m.
	With do.	„	+ 5 „ „ 60 m.
(b)	Without Ether.	+147 volts.	+15 divs. in 60 m.
	With do.	„	+13 „ „ 60 m.
(c)	Without Ether.	-149 volts.	+ 1 div. in 60 m.
	With do.	„	+ 2 „ „ 60 m.

In (c), since the liquid has a positive charge, any loss of charge due to evaporation should give a negative deflexion.

Thus even with this rapid evaporation no loss of charge due to evaporation can be detected.

It only remains to show what loss of charge could be detected by the apparatus used in these experiments. The capacity of the system shown in fig. 2 was found to be 152 c.g.s. units, the increase on that of fig. 1 (viz. 83) being:

probably due to the introduction of the flat rod along the axis of the guard-tube, as the dimensions and distances of the other parts of the apparatus were practically the same as in fig. 1. In these experiments, however, with hot water and with ether, the sensitiveness of the electrometer had been increased to 45 divisions per Clark cell. From these values, taking as before one-fifth of a division per minute as the minimum deflexion which could be relied upon, we get for the minimum loss of charge per second per unit area which could have been detected,

$$q = 1.06 \times 10^{-6} \text{ electrostatic units.}$$

While occupied with the experiments described above my attention has been directed to a second paper by Schwalbe, published this year (*Wied. Ann.* 1900, Band i. No. 2, p. 294). Besides criticising Pellat's method he gives the results which he has obtained on repeating his own earlier experiments, but using on this occasion potentials similar to those used by Pellat, and giving both positive and negative charges to the liquid. He comes once more to the conclusion that they do not support the theory of a loss of charge by evaporation.

I desire to take this opportunity of expressing my thanks to Professor J. J. Thomson for the interest he has shown in this work, and for his kindness in giving me every facility for carrying it out.

Cavendish Laboratory, Cambridge, July 1900.

XLVIII. *On the Arc Spectra of some Metals, as influenced by an Atmosphere of Hydrogen.* By HENRY CREW*.

THE orderly arrangement of lines in the arc spectra of metals belonging to the first and second groups of Mendelejeff's Table, and the apparent disorder among the lines of the remaining groups, constitute one of the most striking features of spectroscopic science in its present state. That this disorder is only apparent is evident not alone on *à priori* grounds but also from the fact that, among these very elements, many pairs and groups of lines with constant frequency-differences have already been discovered. One great barrier to the discovery of more complete order in these spectra is the enormous number of lines with which the metals of these groups are burdened.

In order to simplify matters, the first step would, therefore, appear to be the discovery of some basis upon which the spectral lines of any one element might be separated into

* Communicated by the Author.

smaller divisions. Such an analysis would, at least, greatly increase the chances of finding new series.

Such a basis of division has been already hinted at by Kayser*, who found that nearly two-thirds of all the reversed lines of palladium were arranged in triplets having the same frequency-differences. In short, reversibility appears to be a distinguishing feature of a group of palladium lines whose law of distribution is yet unknown.

It occurred to the writer that possibly another basis for division might be found in the effects produced by surrounding the arc with various atmospheres of gas, as, for instance, hydrogen, nitrogen, coal-gas, ammonia.

The experiment† with hydrogen was tried as follows:— An arc was operated between two metallic electrodes, one of which was in rapid rotation while the other was fed in slowly by means of a screw. This arc, including the rotating electrode, was placed in a brass hood which was made of two parts, not unlike the Magdeburg hemispheres, except that these two hemispheres, instead of having flat faces, were threaded with a screw and provided with accurately turned flanges, so that, when closed, the hood was gas-tight.

Into one of these hemispheres were fitted the two electrodes, one by means of a gas-tight bearing, the other by means of a gas-tight nut-and-screw. It was necessary, of course, to insulate at least one of these electrodes from the brass hood; this was done by placing the nut-and-screw on a slate plate which, in turn, was screwed on to the brass hood.

The shaft which carried the rotating electrode and the current could, therefore, touch the brass hood with impunity; but, as a matter of fact, this was not the case.

On the contrary, the shaft fitted loosely into a bearing which was packed with clean asbestos. This packing served not only the purpose of insulation, but also to prevent any oil reaching the interior of the hood. Consequently no hydrocarbons were formed at the arc unless from carbon impurities in the electrodes themselves.

On the side opposite the arc, the hood was provided with an opening into which screwed a brass tube about one foot long. At its outer end, this tube carried an image-lens of

* Kayser, "Bogen spectren der Elementen der Platin-gruppe," *Abh. Berl. Akad.* 1897, p. 42.

† The entire apparatus described below and the experiments depending upon it were made possible only through the generous consideration of the Committee of the American Academy of Science in charge of the Rumford Fund.

quartz, which projected the arc upon the slit of a 10-foot concave Rowland spectrograph.

The hydrogen was furnished by three electrolytic cells, made with sheet-lead electrodes in dilute sulphuric acid. Each cell absorbed 12 amperes of current, so that the hydrogen produced by 36 amperes was continually flowing through the hood. This hydrogen, which was introduced through a stopcock on one side, was allowed to escape through a stopcock on the opposite side of the hood, where it burned continuously as a "pilot" flame about 2 centimetres high.

In the current of hydrogen, a trap, instead of a drying-tube, was used; for it was found by experiment that there was no difference in effect between hydrogen which had been dried by phosphorus pentoxide and sulphuric acid, and hydrogen which had not been dried at all.

The most marked effect of hydrogen on the arc spectrum is a general diminution of intensity. Consequently, in order to photograph the spectrum of the arc *in hydrogen* so as to give, on the negative, an average intensity equal to that of the arc *in air*, one must make the exposure in hydrogen from 5 to 100 times as long as in air.

The most interesting effect of the hydrogen atmosphere, however, is not the change in the average intensity of the entire spectrum, but the change of relative intensity in the lines of any one substance.

This change was studied by photographing on each negative three spectra, side by side. The first was that of the arc in air, the second that of the arc in hydrogen, the third again that of the arc in air. But the exposure was always so timed that the spectrum in hydrogen had an intensity which was intermediate between the two intensities in air. The advantage of this is that, in comparing intensities, if a line is apparently weakened one has a still weaker spectrum with which to compare it, and, hence, can decide whether the weakening is due to under-exposure or due to some effect on this particular line and not on the whole spectrum. In like manner, if a line is apparently intensified, one has a still stronger spectrum with which to compare it, and to convince himself that the intensification is not due to over-exposure.

The effects of hydrogen on the spectra of magnesium and zinc are partially summarized in Tables I. and II., which follow.

TABLE I.

Arc-Spectrum of Magnesium in an Atmosphere of Hydrogen.

<i>Wave-length of lines which are relatively</i>			<i>Remarks.</i>	
<i>Intensified.</i>	<i>Weakened.</i>	<i>Unaffected.</i>		
4481		5711·31 5528·64 5183·79 5172·86 5167·50	} Second Subordinate Series of Kayser and Runge.	
		[5007·47]		First head of magnesium-oxide fluting. This, and the six following bands, are completely blotted out owing to the absence of oxygen.
			4730·42	Line too weak for comparison.
			4703·18	Widened towards red.
		4571·28		Intensity halved.
				Intensity increased, perhaps, ten times: line enormously widened: does not appear in the ordinary carbon-magnesium arc.
			4352·08	Widened towards red.
		[4216·12]		Cyanogen, Band II., which ordinarily appears as an impurity, is completely blotted out, owing to the absence of nitrogen.
			4167·81 4058·45 3987·08	Cyanogen, Band III., impurity, completely blotted out.
		[3883·55]		
			3838·44 3832·45 3829·50	} First Subordinate Series of Kayser and Runge.
		[3590·48]		
			3336·82 3332·33 3330·04	} Second Subordinate Series.
			3097·01 3093·09 3091·18	

TABLE I. (continued).

Wave-lengths of Lines which are relatively			Remarks.
Intensified.	Weakened.	Unaffected.	
		2942·21 2938·67 2936·99	} Second Subordinate Series.
2936·61			
2928·74			Strong spark-line.
	2852·22	2915·57	Strong spark-line.
		[2852·22]	} First Subordinate Series. From analogy, the first line of this triplet, here covered by the heavy spark-line, ought to be unaffected by hydrogen.
		2848·53	
		2846·91	
		2802·80	Intensity unaffected: reversal greatly increased.
		2798·07	
		2795·63	Reversal greatly increased. A second reversal, not occurring in the ordinary arc, appears in the shade of this line, at a distance of 0·7 tenth-metres toward the violet.
		2790·88 2783·08 2781·52 2779·94 2778·38 2776·80	Width and reversal increased.
	2768·57		

The line at 2765·47 and the five triplets of still shorter wave-length which complete Kayser and Runge's list of magnesium lines, are so entirely blotted out by the hydrogen atmosphere that no comparison is possible even on plates of four hours' exposure. And this is true even while many sharp lines, impurities, of still shorter wave-length appear on the negative.

TABLE II.
Spectrum of Zinc Arc as modified by an Atmosphere of Hydrogen.

Wave-lengths of lines which are relatively			Remarks.
Intensified.	Weakened.	Unaffected.	
5182·20		4810·71 4722·26 4680·38	} Second Subordinate Series.
	4630·06		Shading towards red greatly increased.
	4298·54 4293·02 4101·94		} Too faint for reliable comparison : apparently weakened.
	[3683 63]		} Two very persistent lead-lines which, as impurities, are greatly weakened by hydrogen.
	[3639·72]		
		3315·26 3346·04	} Not strong enough for comparison.
		3345·62 3345·13 3303·03 3302·67 3282·42	} First Subordinate Series.
	3075·99		
		3072·19 3035·93 3018·50	} Second Subordinate Series.
	2781·33	2801·00	
		[2771·05]	Not found.
		2770·94 2756·53	
		[2751·49] [2736·96]	} No trace of these lines in hydrogen.
		2712·60 2684·29 2670·67	} Second Subordinate Series.
		[2623·87]	Invisible in hydrogen.
		2608·65 2582·57 2570·00	} Last triplet visible on hydrogen nega- tive after two hours' exposure.
2558·03 2502·11			} Strong spark-lines.

The lines 2601·03, 2575·15, 2562·70, 2138·3, and the remaining six triplets of Kayser and Runge could not be obtained in the hydrogen arc under any reasonable exposure.

The Iron Spectrum.

In the case of the iron arc, the number of lines is so enormous that we can here merely illustrate the effects of a hydrogen atmosphere by giving the principal changes which occur in the region covered by a single negative. In the *first* column of the following table is given the wave-length of the line. These wave-lengths are reliable only to about 0·05 of an Ångström unit. The *second* column gives the intensity of the line in an atmosphere of hydrogen, on a scale which runs from "1" for lines just easily visible to "10" for the very heavy lines. In the *third* column is given the effect produced by hydrogen. Here the word "new" is used to indicate that the line does not appear in the ordinary iron arc. "Enh." is a contraction for the word "enhanced"; and the number which follows "enh." is intended to indicate, roughly of course, how many times greater the intensity of the line is in hydrogen than in air. The term "Dim." is a contraction of "diminished;" and the number following it indicates how many times weaker the line is in hydrogen than in air.

The illustrations given are sufficient to show that the hydrogen atmosphere does more than slightly alter these spectra: it profoundly modifies them.

The explanation of these changes may be simple; but it is not patent. A number of hypotheses thrust themselves upon one's attention; but as a rule they are very difficult to test by experiment, and they have therefore little value. For instance, it does not appear impossible that the resistance of the arc may vary considerably with the nature of the atmosphere surrounding it: and, if so, then the temperature and the spectrum may vary. But whether, in such case, hydrogen would serve to increase or to diminish the temperature, it is not easy to predict.

In nearly all the spectra which I have photographed an average direct current of about 2 amperes has been employed, while the pressure between the electrodes has varied from 75 to 100 volts. The current was constantly varying in intensity, and was often completely interrupted. Is it not possible that an atmosphere of hydrogen increases the rapidity of these interruptions, and hence alters the effects of self-induction, thereby changing the temperature of the arc?

Still a third hypothesis is that the introduction of hydrogen

TABLE III.

Illustration from Spectrum of Iron Arc in Hydrogen.

Wave-length.	Intensity.	Description.	Wave-length.	Intensity.	Description.
4056.13	8	New.	3666.95	7	Enh. 8.
4039.03	7	New.	3660.76	2	New.
4027.27	8	New.	3659.09	7	Enh. 20.
4000.12	6	New.	3652.50	3	Enh. 10.
3997.16	10	Enh. 10.	3652.22	3	Enh. 10.
3944.54	7	Enh. 10.	3648.52	3	Enh. 8.
3941.02	1	Dim. 7.	3645.24	6	Enh. 10.
3938.37	4	New.	3643.78	2	Dim. 2.
3928.74	4	Enh. 6.	3642.67	4	New.
3926.57	8	Enh. 4.	3630.46	1	Dim. 2.
3920.91	10	Enh. 7.	3626.90	3	New.
3917.97	10	Enh. 8.	3625.27	2	Dim. 2.
3910.79	10	Enh. 10.	3620.07	8	Enh. 10.
3906.61	2	Dim. 5.	3616.71	7	Enh. 5.
3899.85	3	Dim. 4.	3615.88	7	Enh. 5.
3899.19	12	Enh. 6.	3612.20	1	Dim. 4.
3898.09	5	Dim. 2.	3607.44	7	Enh. 10.
3897.61	8	Enh. 4.	3602.60	2	Dim. 2.
3889.31	5	New.	3598.94	8	Enh. 8.
3866.97	5	Enh. 10.	3594.68	3	Dim. 3.
3864.28	5	Enh. 5.	3593.55	6	Enh. 3.
3861.66	5	New.	3583.02	6	Enh. 10.
3850.48	4	New.	3573.15	5	Enh. 5.
3843.93	8	Enh. 6.	3572.06	2	Dim. 2.
3825.13	4	Enh. 10.	3540.53	3	Enh. 10.
3814.63	1	Dim. 4.	3538.76	5	Enh. 10.
3807.64	2	Dim. 5.	3507.15	5	Enh. 10.
3801.79	8	Enh. 4.	3499.34	4	Enh. 10.
3800.57	8	New.	3493.60	4	New.
3790.23	3	Dim. 2.	3491.22	3	Enh. 4.
3786.82	1	Dim. 4.	3474.19	2	Enh. 4.
3781.79	3	New.	3465.98	4	Dim. 2.
3775.81	3	New.	3460.43	2	Enh. 4.
3771.71	5	New.	3323.20	2	New.
3767.78	6	Enh. 10.	3281.40	2	New.
3759.28	3	Enh. 8.	3277.55	3	Enh. 5.
3739.98	10	Enh. 10.	3274.09	1	Dim. 5.
3724.09	4	Enh. 8.	3265.17	0	Dim. 6.
3723.30	4	Enh. 8.	3264.64	0	Dim. 4.
3718.04	3	New.	3259.17	6	New.
3706.16	3	Enh. 10.	3258.89	4	New.
3700.36	4	New.	3257.70	2	Dim. 2.
3692.92	5	New.	3251.36	0	Dim. 5.
3692.08	5	Enh. 12.	3247.67	1	Dim. 6.
3688.29	6	Enh. 10.	3246.13	0	Dim. 10.
3683.19	3	Dim. 3.	3243.87	2	Enh. 4.
3680.08	4	Dim. 2.	3237.95	2	New.
3671.78	2	Enh. 4.	3236.35	1	Dim. 8.
3668.50	6	Enh. 7.	3234.75	0	Dim. 10.

prevents the formation of oxygen and nitrogen compounds, thus blotting out some lines: and that it permits the formation of hydrogen compounds, thus accounting for the appearance of new lines.

Whatever the explanation may be, the following curious relation was found to exist between the arc and spark spectra, namely, *all lines in the arc spectra which are affected by hydrogen, whether enhanced or diminished, belong to the spark spectrum also.*

To illustrate: the arc spectrum of tin in hydrogen shows two strong lines at λ 3352.15 and λ 3283.31, of which there is not the faintest trace in the ordinary tin arc. But these two are among the strong lines of the tin spark. See Hartley and Adeney's list. In like manner, I have photographed, on the same plate, the iron spark in air, the iron arc in air, and the iron arc in hydrogen. In every case examined, the lines affected by hydrogen are spark-lines.

On the contrary, *the lines which belong to Kayser and Runge's series are unaffected by the change from air to hydrogen.*

If these series prove equally stable in other gases, this stability may form a criterion for dividing a spectrum into two groups—one of which will contain all the series lines, the other of which will contain none of them.

North-Western University,
Evanston, Illinois.
July 1900.

XLIX. *On a Diagram of Freezing-point Depressions for Electrolytes.* By Prof. J. G. MACGREGOR, F.R.S., Dalhousie College, Halifax, N.S.*

[Plate IV.]

THE object of this paper is to describe a diagrammatic method of taking a bird's-eye view of such knowledge as we possess of the relation of the depression of the freezing-point to the state of ionization in aqueous solutions of electrolytes, and to show that such diagrammatic study gives promise of throwing much light upon the following questions:—(1) † Has the depression-constant a common value for all electrolytes, and if so what is it? And (2) what is the state of association, and what the mode of ionization, of electrolytes in solution?

* Communicated by the Author. An abstract of a paper read before the Nova Scotian Institute of Science.

† On this question see also a paper recently communicated to the Royal Society of Canada, and to be published in its Transactions for 1900.

Construction and Properties of the Diagram.

If an extremely dilute solution contain an electrolyte whose molecule as it exists in solution contains p equivalents and dissociates into q free ions, and if α is its ionization-coefficient, and k its depression-constant, the equivalent depression will be :

$$\delta = \frac{k}{p} (1 + \alpha(q-1)).$$

If, therefore, we plot a diagram of curves with ionization-coefficients as ordinates, say, and equivalent depressions as abscissæ, the resulting curves must at extreme dilution ($\alpha=1$) be tangential to the straight lines represented by the above equation, provided the proper values of k , p , and q be employed. These straight lines, which for shortness we may call the tangent lines of the curves, can readily be drawn in the diagram with any assumed value of k , and on any admissible assumptions as to the values of p and q . In the diagram (Pl. IV.) the broken lines are the tangent lines for the electrolytes examined, on various assumptions as to constitution in solution and mode of ionization, and for $k=1.85$. They are indicated by the inscriptions 1-2, 2-3, &c., the first figure in each giving the number of equivalents in the molecule as it is assumed to exist in solution, and the second the number of free ions into which the molecule is assumed to dissociate. Thus 1-2 is the tangent line for an electrolyte such as NaCl, on the assumption that it exists in solution in single molecules, each of which has therefore 1 equivalent and dissociates into 2 ions. If assumed to associate in double molecules with unchanged mode of ionization, its tangent line would be indicated by 2-4; and if the double molecules were assumed to dissociate into Na and NaCl₂, by 2-2. The line for H₂SO₄ on the assumption that its molecules undergo no association and have thus 2 equivalents, and that they dissociate each into 3 ions, would be indicated by 2-3.

In a few cases dotted lines have been introduced to show what the tangent lines would be with other values of k , 1.83, &c., the constant used in such cases being indicated.

The curve for any given electrolyte must start at the intersection of its tangent line with the line $\alpha=1$, to which point we may refer for shortness as the intersection of its tangent line. What its form will be may be anticipated from the following theoretical considerations:—The equivalent depression in dilute solutions of non-electrolytes is proportional to the product of the osmotic pressure, P , and the dilution, V , which corresponds to the product of the pressure p and specific

volume, v , in the case of a gas. If pv is plotted against v , the resulting curve is convex towards the axis of v , and passes in general through a point of minimum value of pv . Hence if PV , and therefore equivalent depression, be plotted against V , we may expect to get curves of the same general form. And experiment shows that in some cases at least we do. As in the case of gases the variation of pv is ascribed to the mutual action of the molecules and their finite volume, so in the case of solutions the variation of PV is attributed to similar disturbing influences.

Owing to ionization the curve of an electrolyte will differ from that of a non-electrolyte (1) because of the change thereby produced in the number of the molecules (including free ions) in unit of volume, and (2) because of the change produced in the disturbing influences referred to. The former change is doubtless the more important, and I shall assume the latter to be negligible, for the present purpose. Now dissociation increases continuously with dilution. If therefore association of molecules does not occur, and if the mode of ionization does not change, the equivalent depression must be increased by the dissociation in a ratio which increases continuously with dilution. The change produced in the curve by dissociation, therefore, will be a shear parallel to the equivalent depression-axis and increasing with dilution. The resulting curve will consequently remain convex towards the axis of dilution, but it will be less likely than the curve of a non-electrolyte to exhibit the minimum point.

If now we plot equivalent depression against ionization-coefficient, instead of dilution, the result will be the same as if we shortened the dilution ordinates of the various points of the curve just mentioned, in ratios increasing with the dilution; which process must leave the curve convex towards what was the dilution-axis, but is now the ionization-coefficient axis.

If therefore no change occur in the association of molecules or in the mode of ionization, the curve of an electrolyte on the diagram must start at the intersection of its tangent line, tangentially to that line, and bend away from it, as dilution diminishes, to the right, possibly passing through a point of minimum equivalent depression. We may speak of such a curve as the normal curve for the tangent line corresponding to the given conditions as to constitution in solution and mode of ionization.

If, the constitution of the electrolyte in the solution remaining constant, the mode of ionization changes as dilution diminishes, say in such a way that the molecules dissociate

on the average into a smaller number of ions, the equivalent depression will diminish more rapidly than it otherwise would. The curvature of the curve will therefore diminish and may possibly become zero and change sign, the curve thus becoming concave towards the ionization-coefficient axis and possibly crossing the tangent line. In such a case the curve will at the start coincide with the normal curve of the tangent line determined by the initial conditions as to association and mode of ionization, and at the finish with the normal curve of the tangent line determined by the final conditions; and between the start and the finish it will gradually change from the one to the other.

If, as dilution diminishes, association of molecules into double or other multiple molecules occurs, the mode of ionization remaining the same, the equivalent depression will be thereby made to diminish more rapidly than it otherwise would, and the general effect on the form of the curve will be of the same kind as under the conditions just considered. But the normal curves of the tangent lines determined by the final conditions will be quite different in the two cases.

It follows that by plotting, so far as experiment allows, the curves of observed equivalent depression against ionization-coefficient, and drawing in the tangent lines for different values of the depression-constant and on different assumptions as to association and mode of ionization, we may be able to determine, with a smaller or greater probability, what the state of association and the mode of ionization are, what are the tangent lines to whose intersections the curves would run out if observations at extreme dilution could be made, and what the values of the depression-constant are to which these lines correspond.

Data for the Diagram.

To draw the experimental curves, we must have corresponding values of the depression and of the ionization-coefficient at the freezing-point, or what in most cases will be sufficiently near, at 0° C. The former are obtained by direct measurement; but the latter only indirectly from conductivity observations. It is not of course known how closely the ionization-coefficients, even during the passage of the current, can thus be determined, or if the state of ionization during the passage of the current is to be regarded as being the same as when the current is not flowing. But as it has been shown that electrically determined coefficients enable us to predict, within the limit of error of observation, not only

the conductivity and results of electrolysis* of moderately dilute complex solutions, but also their density, viscosity, and other non-electrical properties†, it would appear to be probable that for moderately dilute and very dilute solutions electrically determined coefficients are approximately exact, not only for a solution through which a current is passing, but generally.

The available data as to ionization-coefficients at 0° are unfortunately few. Whetham‡ has recently published some most valuable determinations, having measured the conductivity at 0° of series of solutions down to extreme dilution, with what one may call *appareil de luxe*, and found the ratio of the equivalent conductivity to the maximum equivalent conductivity. For neutral salts his coefficients must inspire great confidence. But in the case of the acids they seem to me to be probably too high. For the maximum equivalent conductivity of an acid is probably lower than it would be, were it not for the disturbing influence, whatever it is, which makes the equivalent-conductivity-concentration curve not only reach but pass through a maximum point, as concentration diminishes.

Archibald and Barnes§, working in my laboratory, measured the conductivity both at 0° and 18° for series of solutions down to dilutions at which the ratio of the two conductivities became constant; and assuming that the same ratio would hold at extreme dilution, they calculated the equivalent conductivity at extreme dilution for 0° from Kohlrausch's values for 18°. They used this method only because appliances were not available with which observations at extreme dilution could be made. If the ratio mentioned really does become constant as dilution increases, the method is likely to give coefficients with too low or too high values according as the ratio at moderate dilutions diminishes or increases with dilution (it was found to increase with KCl and K₂SO₄). For it will probably become constant within the limit of error of observation before it has really reached constancy. And if it changes with dilution in a slightly wavy manner, even though on the whole tending to constancy, it may be regarded as having become constant when really passing through a maximum or minimum point.

* Trans. Roy. Soc. Can. (2) iv. sec. 3, p. 117 (1898).

† See Phil. Mag. [5] xliii. pp. 46 & 99 (1897); also Archibald, Trans. Nova Scot. Inst. Sci. ix. p. 335 (1897-98); and Barnes, *ibid.* x. pp. 49 & 113 (1899-1900).

‡ *Zschr. f. phys. Chem.* xxxiii. p. 344 (1900).

§ Archibald, Trans. N. S. Inst. Sci. x. p. 33 (1898-9); Barnes, *ibid.* x. p. 139 (1899-1900); and Trans. Roy. Soc. Can. [2] vi. (1900).

Déguisne's* observations on the variation of conductivity with temperature between 2° C. and 34° have enabled me, by the method just mentioned, to make rough determinations of the ionization-coefficients at 0° in some cases, on the assumption that his empirical constants might be used down to 0°. According to Déguisne's observations the ratio of the conductivities at 0° and 18° usually changes gradually down to dilutions of 1000 litres per gramme-equivalent, and between that and 2000 undergoes rapid change. As observations at great dilution are attended by considerable difficulty, I have assumed that these sudden changes were probably due to errors of observation. If they were not, my Déguisne coefficients (for which Déguisne himself is of course not to be held responsible) may be considerably out.

In some cases I have obtained coefficients from the above data by extrapolation, in order to make use of available depression data. In such cases I have plotted side by side ionization-coefficient-concentration curves for both 0° and 18°, using values for 18° based on Kohlrausch's conductivities, and I have then produced the 0° curve beyond the limit of observation under the guidance of the 18° curve.

I need not give here the values of the coefficients used in the diagram. They will be found in the paper† of which this is an abstract, and have been fairly accurately embodied in the accompanying diagram (Plate IV.).

I have used all the accessible observations of depression for the electrolytes for which data were available as to ionization at 0°, including observations by Arrhenius‡, Raoult§, Loomis||, Jones¶, Abegg**, Wildermann††, Ponsot‡‡, Archibald§§, and Barnes§§. The methods used by these observers are for the most part well known. Archibald and Barnes used modified forms of Loomis's method. Arrhenius's observations and some of Raoult's were made before important

* *Temperatur-Coefficienten des Leitvermögens sehr verdünnter Lösungen*: Dissertation, Strassburg, 1895; see also Kohlrausch u. Holborn, *Leitvermögen d. Elektrolyte*, Leipzig, 1898.

† Trans. N. S. Inst. Sci. vol. x. Part 2 (not yet published).

‡ *Zschr. f. phys. Chem.* ii. 491 (1888).

§ *Ibid.* ii. p. 501 (1888); and xxvii. p. 617 (1898).

|| *Phys. Review*, i. pp. 199 & 274 (1893-4); iii. p. 270 (1896); and iv. p. 273 (1897).

¶ *Zschr. f. phys. Chem.* xi. pp. 110 & 529 (1893); and xii. p. 623 (1893).

** *Ibid.* xx. p. 207 (1896).

†† *Ibid.* xix. p. 233 (1896).

‡‡ *Recherches sur la Congélation des Solutions Aqueuses*: Paris, Gauthier-Villars (1896).

§§ *Loc. cit.*

improvements in freezing-point determinations had been recognized as necessary.

In cases in which there was but one series of observations available, I have plotted the actual observations in the diagram, though sometimes smoothing the curves a little. In cases in which two or more series were available, I first plotted the various observations and then drew mean curves, making them represent all the observations as well as I could, but giving greater weight to recent observations than to those of earlier date, and to long series of consistent observations than to short series or to series which were more erratic. These mean curves were then entered in the diagram.

The curves are labelled with the initial letters of observers' names (R for Raoult, &c., A for Archibald, Ab for Abegg), so as to show both the depression-observations on which they are based, and the ionization-coefficients used in plotting them. Thus the inscription KCl (J-W) means that Jones's depressions and Whetham's coefficients were used; H_2SO_4 (JLB-B), that the curve is a mean curve based mainly at least on depression-observations by Jones, Loomis, and Barnes, and plotted with Barnes's coefficients. The limits of concentration for the curves are indicated also in gramme-equivalents per litre. The equivalent depressions plotted are in all cases depressions per gramme-equivalent in one litre of solution.

Some of the curves are entered on an inset drawn on four times the scale of the main diagram.

In interpreting the curves we must not only bear in mind what has been said above about the probable accuracy of the ionization-coefficients, but must in addition note the tendency exhibited by the curves of the various observers, as dilution increases, to run off at great dilution in directions, characteristic of the observers, to the left or right relatively to the course pursued by them at moderate dilution. Thus Abegg's curves (see NaCl, KCl, K_2SO_4) and Jones's (see NaCl, KCl, NH_4Cl , and HCl) run off to the right. So do Arrhenius's (not plotted), in a marked manner. Raoult's tendency is also to the right (see NaCl; his K_2SO_4 , not plotted, shows it also; his most dilute KCl observation he himself clearly regards as accidentally out). On the other hand, Loomis's curves (see HCl, KNO_3 , NH_4Cl , BaCl_2) go to the left. So do Ponsot's and probably Wildermann's (not plotted). And I gather from Ponsot's diagrams of Pickering's observations, to which I have not access, that Pickering's also have the leftward tendency. Archibald's and Barnes's curves show

less tendency to diverge than those of any other observers. And although this may be partially, it is not wholly, due to their having worked at moderate dilution only; for in several cases, pointed out below, the curves of other observers start on a divergent course within their limit of dilution. But the fact that their curves usually agree with Loomis's would lead one to suspect them of a leftward tendency also.

The divergence, as shown on the diagram, is most marked in the case of highly dissociated electrolytes (NaCl , HCl , &c.), in which at great dilution the rate of increase of ionization with dilution is small, the curves being crushed up, therefore, into a small space. But it is obvious also in the K_2SO_4 curves (especially Abegg's) and the BaCl_2 curves (including Ponsot's, not shown). And although for MgSO_4 and H_3PO_4 , whose ionization increases rapidly with dilution, the single curves do not reveal it, the relative positions of the two curves in each case are what they might be expected to be, if they were tending unduly, Jones's to the right and Loomis's to the left.

This tendency is explicable at once when we reflect that as it is equivalent depression that is plotted, the errors of the observations are brought into greater and greater prominence as dilution increases. According, therefore, as the characteristic error of an observer's method of measuring total depression is positive or negative, will his curves of equivalent depression diverge at great dilution to the right or left of their true course; and they must diverge even if the error is very small.

The equivalent-depression curves of individual observers are therefore open to grave suspicion at high dilutions; and since one can never be sure that the errors of different methods will even approximately neutralise one another, mean high-dilution curves are not much more trustworthy than their components*. It is much safer, therefore, to base

* It is consequently inadmissible to proceed as Raoult has done, in determining depression-constants (*loc. cit.* p. 658), viz., by selecting high-dilution curves which are in agreement and applying extrapolation to a mean curve derived from them; for such procedure may involve the selection of observations made by methods which have characteristic errors of the same sign. In fact a mean curve based on observations which agree well at low dilution, but disagree markedly at high dilution, would be likely to give a better result, as more probably combining observations with small characteristic errors of opposite sign. Raoult's procedure is open to other objections. For (1) his curves of equivalent depression against total depression make series of observations appear to be in greater disagreement than they really are, and are thus not helpful in making a judicious selection of observations to be used; and (2) extrapolation of such curves not only gives a result affected by the

conclusions as to depression-constants on moderate-dilution curves, although the conclusions they admit of may not be so exact as we might wish.

Discussion of the Curves.

Electrolytes such as KCl , HNO_3 , KOH , have 1 equivalent in the single molecule and 2 ions. If, therefore, they exist in solution in single molecules, their curves will be normal 1-2 curves. If their molecules are all double or triple, the curves should be 2-4 or 3-6 curves, provided association does not involve change in the mode of ionization. If it does, they may be 2-3 or 3-4, 3-3 or 3-2 curves respectively, according to the change that may occur. If the molecules are single at extreme dilution, but become double or triple as dilution diminishes, the curves should start as 1-2 curves and undergo the appropriate transformation.

The electrolyte for which we have the most complete and trustworthy data is KCl . The LB-B curve (see main diagram) is based for the most part on two series of observations in close agreement and by methods exhibiting less divergence than the others. Jones's curve runs a little to the right of it; Abegg's a little to the left. Both Raoult's and Wildermann's cross it, the latter being somewhat steeper, the former less steep. Ponsot's coincides with the lower part of it, but in the upper part diverges to the left. In form the curve is thus probably trustworthy; but, being plotted with Barnes's coefficients, it may be too high or too low. The R-W and J-W curves (see inset), are not open to this suspicion, but at the dilutions to which even their lower and more trustworthy parts apply they may have begun to diverge unduly rightwards. If the LB curve is plotted with Whetham's coefficients (extrapolated) it comes into a position (see LB-W curve on inset) to the left of the R-W and J-W curves, the usual relative position of the curves of these observers. Loomis's own curve for somewhat greater dilutions than those of the LB-W curve, when plotted with Whetham's coefficients, coincides very nearly with the boundary-line of the inset. Wildermann's is a little to the left of Loomis's, and somewhat steeper. Both exhibit a slight rightward bending, as do all the others.

average of the characteristic errors of the observations used, but also neglects the possibility, in some cases the probability, that owing to change in association and mode of ionization the law of the change of curvature may be very different beyond the limits of observation from what it is within these limits.

It would be difficult to draw a mean curve with confidence; but any such curve would run about midway between the 1-2 and 2-4 (1.85) lines, would have a slight rightward bending at its upper end, and if produced with diminishing curvature would run out to a point a little to the right of the 1-2 (1.85) intersection.

If this intersection were the starting-point of the curve and if there were no association, the curve should lie wholly to the right of the 1-2 (1.85) line. If, as dilution diminished, sufficient doubling of molecules with unchanged mode of ionization should occur, the curve, after first bending away from that line to the right, would change its curvature, bend towards the line and cross it, and then run towards and finally away from the 2-4 line, as the mean curve appears to do.

As the 2-2 line is far to the left, the mean curve might be accounted for also on the assumption of a very slight formation of double molecules dissociating into two ions—a formation of such molecules so slight as probably to involve no greater variation of the migration numbers with concentration than has been observed.

If the 1-2 (1.86) intersection be assumed as the starting-point of the curve, the mean curve would cut the 2-4 (1.86) line. If, therefore, association in molecules with unchanged mode of ionization were assumed, some formation of triple molecules would be indicated, and if the associated molecules were assumed to dissociate into two free ions, a greater extent of such association would be indicated. Thus with this starting-point less probable assumptions as to association must be made to account for the observations.

If the 1-2 (1.84), or even the 1-2 (1.845) intersection were taken as the starting-point, the curve must bend considerably to the left before running out, of which bending none of the experimental curves give any indication whatever.

The most probable conclusion then that we can draw from the observations is that the depression-constant is 1.85, with a limit of error of .01 or perhaps .005, that the electrolyte has single molecules at great dilution, and that as dilution diminishes either double molecules with unchanged mode of ionization form to a considerable extent, or double molecules dissociating into two ions, to a small extent.

Loomis's and Barnes's observations on which the NaCl (LB-B) curve is mainly based are also in close agreement; but as Loomis's curve for slightly greater dilution bends slightly to the right, the upper part of the LB-B curve

should probably have greater curvature. Jones's curve for moderately dilute solutions runs a little to the left of it, and at higher dilutions diverges markedly to the right (as separately shown). Abegg's observations are on both sides of it, but at higher dilutions his curve also goes to the right, as shown. Raoult's touches it, but goes off to the right. Arrhenius's (not shown) is considerably to the right throughout, and goes widely rightward at greater dilutions. Ponsot's is a little to the left. As the LB-B curve is plotted with Barnes's coefficients, it is probably too low. If it be raised about 2.5 per cent., the amount by which Whetham's KCl coefficients are higher than Barnes's, it will lie along the 1-2 (1.85) line, or a little above or below that line, with its upper end so directed as to run out probably at a point nearer the 1-2 (1.85) intersection than either the 1-2 (1.83) or the 1-2 (1.87) intersection. The defective data as to ionization prevent our drawing a more definite conclusion than that the association indicated, if any, is less than in the case of KCl, and that the depression-constant is 1.85 with a limit of error of perhaps 0.02.

The HCl curve is interesting as exhibiting a point of minimum equivalent depression. The observations on which the LB-B curve is based are in good agreement. Jones's curve almost coincides with it in the lower part, but goes off to the right in the upper part and at higher dilutions, as shown separately. Loomis's curve at higher dilutions, also separately shown, goes off to the left, but in a less marked manner. As drawn, the upper part of the mean curve lies between the 1-2 and 2-4 (1.85) lines, and it is running out to a point a little beyond the 1-2 (1.86) intersection (see inset). But as it is plotted with Barnes's coefficients it is perhaps too low. If raised from 0 to 2 per cent. it might run out at any point between the 1-2 (1.84) and 1-2 (1.86) intersections. The data are of course very defective, but they are consistent with a depression-constant of about 1.85, and they seem to indicate a greater extent of association than in the case of KCl.

The L-D and J-D curves for NH_4Cl (see inset) are not in agreement, having the usual relative position of L and J curves. A mean curve based on their lower parts would be slightly to the left of the 1-2 (1.85) line, and directed to a point considerably to the right of the 1-2 (1.86) intersection. It might thus indicate anything between a high value of the depression-constant, accompanied by very considerable association of molecules, and a constant of about 1.85 without association in dilute solutions, and with only a slowly increasing association in stronger solutions.

The HNO_3 curve (see inset) is a mean curve based on Loomis's and Jones's. Both are beyond the bounds of the inset, the former to the left and the latter to the right. Neither this curve nor that of KNO_3 is sufficiently trustworthy to warrant any close inspection; but both are clearly consistent with the 1.85 value of the depression-constant. If the leftward bending of the KNO_3 curve in its lower part were actual, as well as the position of the curve, the formation of triple molecules might be indicated. But being a Loomis curve, it is open to the suspicion of being as a whole too far to the left, and it is plotted with doubtful coefficients.

The KOH curves, Loomis's on the main diagram and Jones's on the inset, are useful only to illustrate the difficulty of making concordant observations by different methods. As usual, Loomis's is to the left and Jones's to the right.

Electrolytes such as BaCl_2 , H_2SO_4 , Na_2CO_3 have 2 equivalents in the single molecule which may dissociate into 3 or into 2 ions. If there is no association, they will therefore have 2-3 or 2-2 curves according to the mode of ionization. If there is complete doubling of molecules, the curves will be 4-6 or 4-4 curves, provided the doubling does not involve change in mode of ionization. Otherwise they might be 4-5, 4-3, or 4-2 curves. If the molecules are associated in threes, the curves will be 6-9 or 6-6 curves, with the above proviso.

Both Loomis's and Jones's curves for BaCl_2 are shown on the diagram, plotted with Whetham's coefficients (rough extrapolated values, however, in the case of the former). Ponsot's curve agrees very closely with Loomis's. Bearing in mind the rightward and leftward tendencies of Jones's and Loomis's curves respectively, we may conclude from the curves of the diagram that the actual curve runs down to the right of the 2-2 line, bending away from it to the right, and that it would intersect the $\alpha=1$ line at a point between the 2-3 (1.85) and the 2-3 (1.87) intersections, probably nearer the former than the latter. The curve is thus, so far as we can judge, a normal 2-3 ($1.85 \pm .01$) curve, running however very close to the 2-3 line. The diagram therefore indicates that BaCl_2 exists in solution in single molecules, dissociating into three ions, at least for the most part, and that it has a depression-constant nearer 1.85 than 1.87.

The H_2SO_4 (J-W) curve for high dilutions being a Jones curve, is probably too far to the right, and, being plotted with Whetham's coefficients, is probably too high. Wildermann's curve for high dilutions runs parallel to it, considerably to the left. The JLB-B curve for lower dilutions is very nearly coincident with Barnes's curve, and in its lower

part with Jones's and Loomis's as well. But in the upper part Jones's curve goes off markedly to the right, and Loomis's markedly to the left. Wildermann's is slightly to the left at the lower end, and diverges somewhat leftwards in the upper part. Ponsot's runs nearly parallel to it somewhat to the left, and diverges to the left at higher dilutions. The JLB-B curve is thus trustworthy in form, but being plotted with Barnes's coefficients it is possibly too low. The actual curve would thus appear to cross the 2-3 (1.85) line not far from its starting-point, bend towards the 4-6 (1.85) line, and run down below that line, finally bending slightly towards it again. Its course is therefore what it would be if it started as a 2-3 curve for $k=1.85$ or thereabout, changed its curvature at a somewhat early stage, and tended to be transformed slowly into either a double-molecule curve or a 2-2 curve, or perhaps both at once. The diagram would therefore indicate that at extreme dilution H_2SO_4 exists in solution in single molecules dissociating into three ions; that at an early stage and in a somewhat marked manner, either doubling of molecules sets in, or partial dissociation into two ions or perhaps both; that the change increases slowly and steadily as dilution diminishes, and that at a concentration of about 0.6, if the coefficients at this concentration are to be trusted, the change is increasing in rate; also that the depression-constant may quite readily be about 1.85.

The K_2SO_4 (LJA-A) curve is based on series of observations which in the main are in good agreement. It very nearly coincides with the Loomis and Archibald curves, and Ponsot's (not shown) runs down slightly to the left. In its lower part it coincides with the Jones curve, but in its upper part Jones's curve (separately represented for great dilutions) runs off to the right. Abegg's curve for higher dilutions runs much more markedly to the right, though it is farther to the left at its lower end. Arrhenius's (not shown) is considerably to the right and diverges widely rightwards. The Na_2SO_4 (LA-A) curve is also almost coincident with both the Loomis and the Archibald curves. Both Raoult's and Arrhenius's (neither shown) are considerably to the right and diverge slowly rightwards. Such of these curves as are entered on the diagram, being plotted with Archibald's coefficients, are probably too high or too low, as the case may be. Those for great dilutions are too discordant to admit of discussion. The mean curves for both salts have the same general form. They run down, as drawn, a little below the 2-3 (1.85) line. Their upper ends are so directed as to suggest their running out at the 2-3 (1.85) intersection or

thereabout. At their lower ends they turn sharply to the left and cross the 2-3 line, going towards the region of the double-molecule curves or of the 2-2 curve. The turns are too sharp and the 4-6 and 6-9 lines too near to make their transformation probable into double or triple molecule curves with unchanged mode of ionization. The diagram suggests rather their transformation into 4-5, 4, or 2 or 2-2 curves. If this be accepted, it means that at extreme dilution these sulphates exist in solution in single molecules dissociating into three ions, that partial dissociation into two ions or doubling of molecules sets in apparently at an early stage, but increases more slowly than in the case of H_2SO_4 until the dilution has been considerably diminished, when it undergoes rapid increase. A close determination of the depression-constant cannot be made; but even if the curves have to be either raised or lowered a little and if, Loomis's tendency being leftward, their upper ends have to be shifted somewhat to the right, they will be consistent with its being about 1.85.

The Na_2CO_3 curves are too discordant to form a basis for discussion. But either Loomis's curve or a mean curve, or even Jones's curve itself is quite consistent with a depression constant of about 1.85; and both curves indicate the occurrence of rapid association or of rapid change of mode of ionization after considerable diminution of dilution. The fact that Loomis's curves tend towards the left, suggests that the actual curve after starting at the 2-3 intersection may bend considerably to the right before association or change of mode of ionization has advanced sufficiently to change the direction of its curvature.

An electrolyte such as MgSO_4 , according as it may exist in solution in single, double, or triple molecules, and according to their mode of ionization, may have a 2-2, 4-4 or 2, or 6-6, 4, 3 or 2 curve. Jones's curve lies to the right of the 2-2 (1.85) line, bending towards it, and may quite readily be a 2-2 (1.85) curve changing to a 4-4 or 4-2 curve. Loomis's lies between the 2-2 and 4-4 lines. A mean curve would, at a concentration .02, have already crossed the 2-2 line. The data, such as they are, are consistent with the depression-constant having a value of about 1.85, and would indicate single molecules in dilute solutions, doubling of molecules at a very early stage, and a steady increase in association throughout.

According as H_3PO_4 , if it exist in solution in single molecules, may dissociate into 4, 3, or 2 ions, will it have a 3-4, 3-3, or 3-2 curve. If it have double molecules, its curve may be a 6-8, 6-7, &c. to 6-2 curve, according to the mode of ionization. Jones's curve, far to the left of the 3-4 and 3-3

lines, runs down to the right of the 3-2 (1.85) line, bending towards the line. Loomis's lies between the 3-2 and 6-4 lines. A mean curve would be just to the right of the 3-2 line, and might readily run out at the 3-2 (1.85) intersection. This would indicate single molecules in dilute solutions dissociating into two ions, an early occurrence of doubling of molecules, and steady increase in the extent of association as dilution diminished, the double molecules formed dissociating into 4, 3, or 2 ions, but not into more. Although the coefficients with which the curves are plotted are doubtful, the curves are so nearly parallel to the axis of coefficients, that even a considerable error in their determination would not affect the above result.

General Conclusions.

Although the observations on which the above discussion is based are defective, and the particular conclusions drawn are consequently tentative, I think it may be held with some confidence: (1) that the curves of equivalent depression against ionization-coefficient have positions, forms, and slopes such as they might be expected to have on reasonable assumptions as to mode of ionization and constitution in solution, according to the Van 't Hoff-Arrhenius theory of the depression of the freezing-point in solutions of electrolytes; (2) that they are consistent with the depression-constant having a common value of about 1.85 for all the electrolytes examined, and that in the case of the electrolyte for which we have the best data, its curve is not consistent with a greater limit of error in this value than about 0.01, unless improbable assumptions are made with respect to the constitution of the electrolyte in solution; and (3) that the diagram enables us to reach in some cases conclusions of considerable probability with respect to the constitution of the electrolyte in solution and its mode of ionization.

L. The Motion of a Sphere in a Viscous Fluid.

By H. S. ALLEN, M.A., B.Sc.

[Continued from p. 338.]

[Plates I. & II.]

III.

8. Photographic Method of Determining Velocities.

IT was only possible to apply the method already described to cases in which the terminal velocity was small. In order to extend the range of observation it was decided to have recourse to a photographic method. Several ways of

employing photography in the determination of the velocity might be suggested, but the plan finally adopted was as follows.

A photographic plate was placed at the back of the rectangular glass vessel in which the balls were allowed to fall. The plate was illuminated by a series of flashes of strongly actinic light emerging from a small aperture at some distance from the front of the glass vessel. In this way the *shadow* of the ball was thrown upon the plate by each successive flash, giving a permanent record of its position at the corresponding instant. In order to secure a succession of flashes at equal intervals of time, twelve equidistant radial slits were cut round the circumference of a disk, 20 centim. in diameter, kept revolving at a uniform rate; in the course of a revolution each slit was brought opposite a fixed vertical slit on which a beam of light was concentrated by a short-focus condensing lens. It is clear that this arrangement would give a series of images of the ball in a vertical line on the plate, but any one image would be fogged by the light from the remaining flashes. To prevent such a result a metal screen having a vertical rectangular opening was placed between the plate and the back of the glass vessel, and the plate was drawn horizontally past this opening so as to expose a fresh surface to each flash. The glass vessel, screen, and plate were inclosed in a wooden case, in the front of which was a circular aperture closed by a Thornton-Pickard photographic shutter to limit the duration of the exposure.

It will be seen that the degree of success attainable in the measurement of the velocity depends in the first place on the constancy of the rate of rotation of the revolving disk and our ability to measure that rate, and in the second place on the sharpness of the images on the developed plate.

The first requirement was satisfied with a very high degree of accuracy by attaching the disk, with its twelve radial slits, to the fly-wheel of the modification of Froment's electromagnetic engine devised by Lord Rayleigh*. The motor was driven by a current from storage-cells rendered intermittent by a tuning-fork interrupter making about 30 complete vibrations per second. The speed of rotation was obtained by means of a counting-wheel geared to an endless screw on the axle of the motor.

In 36 min. 7 secs. the counting-wheel made 197 revolutions. This gives exactly 11 secs. as the time of one revolution. The counting-wheel possessed 45 teeth, and since

* Phil. Trans. clxxiv. pp. 316-321 (1883).

the movement of a single tooth corresponds to one revolution of the fly-wheel, the period of rotation of the latter is $\frac{1}{45}$ sec. Hence the interval of time between two successive flashes is $\frac{1}{12} \times \frac{1}{45}$ sec. or $\cdot 02037$ sec., very nearly $\frac{1}{50}$ sec.

The second requirement, which is far more difficult to meet, is that the image of the ball should show a sharply-defined outline. To ensure this result the light should issue from as small an opening as possible so as to avoid the formation of a penumbra or region of partial illumination, and at the same time the duration of the flash should be so short that no appreciable motion of the ball takes place. In practice this means that both the fixed and rotating slits should be as narrow as possible.

On the other hand, if the slits are made too narrow the amount of light transmitted will be insufficient to give a developable image.

As the work proceeded considerable improvements were made in order to overcome these difficulties, and the later results show much greater sharpness than the earlier ones, although in the later photographs the balls were moving with greater velocities.

Several sources of light were experimented with, but that which proved efficient, with the additional advantage of simplicity, was a strip of burning magnesium ribbon held in position by a fixed clip.

The plates used were Cadett Lightning, developed with hydroquinone and intensified when necessary.

In order to find the actual and not merely the relative velocities of the falling spheres, it is necessary to determine the relation between the distances measured on the photographic plate and the distances traversed by the spheres in the liquid. This was done by photographing a glass scale suspended in the liquid in the same vertical plane as that passed through by the spheres in their descent. Then the actual velocity of a sphere must bear to the velocity obtained by direct measurement of the plate the same ratio as the distance between two fixed points on the scale bears to the distance between their images.

The plates were measured by means of a travelling microscope, the vernier of which read correctly to the tenth of a millimetre.

The main features of the photographic apparatus are shown in section in the diagram, drawn approximately to a scale of $\frac{1}{12}$. The light produced by burning a strip of magnesium ribbon M, inside the lantern, is brought to a focus by the lens L on an adjustable slit K. It passes through one of the slits in the

revolving disk H, driven by the Froment's engine F, and then in succession through the cardboard shade G, the Thornton-Pickard shutter E, the glass vessel C, and a rectangular aperture in the screen B on to the plate at A.

Fig. 1.

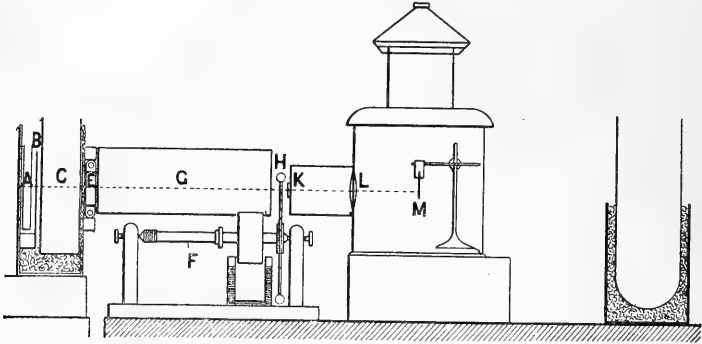

Method of Release.

In order to obtain undisturbed motion through the liquid, it is clear that the sphere must be released beneath the surface. Worthington and Cole* have shown that when a sphere is allowed to fall from air into water, a disturbance of a large body of water takes place and the sphere carries down with it a bubble of air. It therefore became necessary to devise some method of instantaneously releasing the ball under water without giving rise to any appreciable disturbance of the liquid, and without communicating any velocity of translation or rotation to the ball. After trying some mechanical devices, it appeared that by far the simplest method was to suspend the spheres by a small straight electromagnet. As this involved the use of magnetic material for the spheres, it was decided to experiment with bicycle bearing-balls. These could be obtained in six different sizes, with diameters ranging from about 0.3 centim. to 0.8 centim., and careful measurements showed extremely small divergence from true sphericity.

The following sketch shows diagrammatically the method employed for releasing the shutter and the falling weight which gives the plate its horizontal motion, at appropriate instants of time after the ball to be photographed has commenced falling. The release is effected by a second ball dropping in another vessel on to a light platform of aluminium

* Phil. Trans. clxxxix. (A), pp. 137-148 (1897).

foil capable of rotation about a horizontal axis. The depression of this platform makes contact between two mercury cups at T.

The method of procedure is as follows :—The trap at T is adjusted, the rocking-key is placed so as to give contact at R,

Fig. 2.—Diagrammatic View showing the Method of Release.

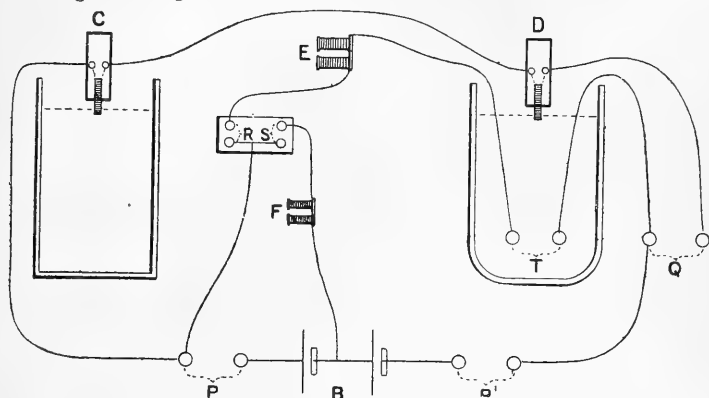

B is the battery comprising a couple of two-volt storage-cells.

C is the small electromagnet by which the ball to be photographed is suspended.

D is an electromagnet similar to C by which the ball working the release is suspended.

E is a larger electromagnet which releases the weight for moving the plate horizontally.

F is an electromagnet for releasing the Thornton-Pickard shutter.

P, P', Q are mercury keys; R, S is a rocking-key; and T is a trap which makes contact when the ball falls from D.

and contact is made at P, P', and Q. The balls are suspended from the electromagnets at C and D, through which the current now runs. The room having been darkened, the photographic plate is inserted in its sheath, and the strip of magnesium ribbon is ignited. When it is well alight contact is destroyed at Q, and the exposure proceeds automatically. For breaking contact at Q sets free the balls simultaneously; the ball falling from D makes contact at T, and a current is sent through the electromagnet E so that the suspended weight is released. This weight in its fall strikes the rocking key so as momentarily to give contact at S instead of R. The current of one cell now passes through P, S, and F, and the Thornton-Pickard shutter is opened.

When the correct height of D above T has been determined for some one position of C, we have only to raise or lower C and D by the same amount to ensure a successful exposure

for any desired fall. In practice failures sometimes occurred, mainly in consequence of the contact at T having to be made under water, the mercury surfaces there being easily contaminated.

The general appearance of the apparatus may be gathered from the figure (Plate I. fig. 1). The vessel in which the fall took place may be seen on the extreme left. In order to prevent the transmission of vibrations to the liquid from the electromagnetic engine (which cannot be seen in the figure), this vessel rested on a stand separated from the table supporting the rest of the apparatus. The aluminium shutter is partly visible between the front of the vessel and the cardboard shade. The inside of this shade, as well as other parts of the apparatus exposed to the light, was painted a dull black. Immediately in front of the lantern are the two storage-cells for working the release. On the right of the picture is the vessel in which the timing sphere falls. The falling weight and its release are on the side of the table not shown in the figure.

The experiments were carried out in a cellar in the Cavendish Laboratory.

Results.

An inspection of the reproductions in Plates I. & II. will show the character of the photographs obtained. Fig. 1 (Pl. II.) in which a glass scale is photographed, shows the actual size of the aperture in the screen. Special care was taken that the upper and lower edges of this aperture should be sharply defined and horizontal, so that they might serve as fixed lines from which to measure the vertical displacements of the spheres. Figs. 2-3 (Pl. I.) & 2-4 (Pl. II.) illustrate the manner in which successive images of the aperture are formed on the moving plate. It will be noticed that at least three flashes occurred during the time the shutter remained open. Since the shutter opened from above downwards, the lower part of the first image and the upper part of the third are generally cut off. In some of the photographs the horizontal velocity of the plate has not been great enough to separate the images completely.

When the falling sphere happens to be in the path of the beam of light, we obtain two or more images of the shadow. An examination of one of these images will show that the opposite edges are most sharply defined in a direction sloping downwards from left to right. This is a consequence of the finite duration of a flash. The direction of the sharp edge is that of the velocity compounded of the separate velocities of the ball and the plate.

9. Accelerated Motion of the Falling Sphere.

We may conveniently consider the motion of a sphere falling in a viscous fluid to be divided into two stages. In the first stage the sphere is moving with continually diminishing acceleration; in the second it is moving with constant "terminal" velocity. Theoretically the second stage is reached only after the lapse of an infinite time, during which the limiting value is approached asymptotically; practically this stage is reached after a very short time.

Measurement of the distance between two images on a plate during the accelerated motion gives the average velocity of the sphere in moving from one position to the other. This average velocity is the velocity at the middle of the time between the two positions, and therefore, except at the very beginning of the motion, is nearly the same as the velocity at the point of space halfway between the two positions.

If a series of photographs of the same sphere at different depths is obtained, we have the means of plotting a curve showing the velocity attained after falling through any height. Such a curve is drawn for the smallest ball, radius .1590 centim., falling in a vessel 11.5 centim. long and 3 centim. wide, in fig. 3. The result would be more regular if greater care had been taken in measuring the height of fall; when these photographs were taken this was only done roughly to serve as a check in determining whether the terminal velocity had been attained.

In the same diagram is shown, as far as limits of space allow, a portion of the corresponding curve for the fall of a body *in vacuo*. Comparison of these two curves shows how effective is the resistance of the fluid in destroying the acceleration of the sphere. The velocity of the sphere has become practically constant after a fall of 20 centim.

Fluid Resistance in Accelerated Motion.

In the case of the smallest ball used, the determinations of velocity at different depths were sufficiently numerous to enable a curve to be drawn showing the relation between the velocity and the fall. The slope of this curve at any point gives the value of $\frac{dV}{ds}$ at the corresponding depth, and so the value of the acceleration $V\frac{dV}{ds}$ may be found.

The ratio of this acceleration to the acceleration of a body

falling *in vacuo* is the same as the ratio of the effective force on the sphere to its weight.

$$\therefore \frac{f}{g} = \frac{W-R}{W},$$

$$\therefore R = \left(1 - \frac{f}{g}\right)W,$$

Fig. 3.—Fall of a Steel Ball in Water.

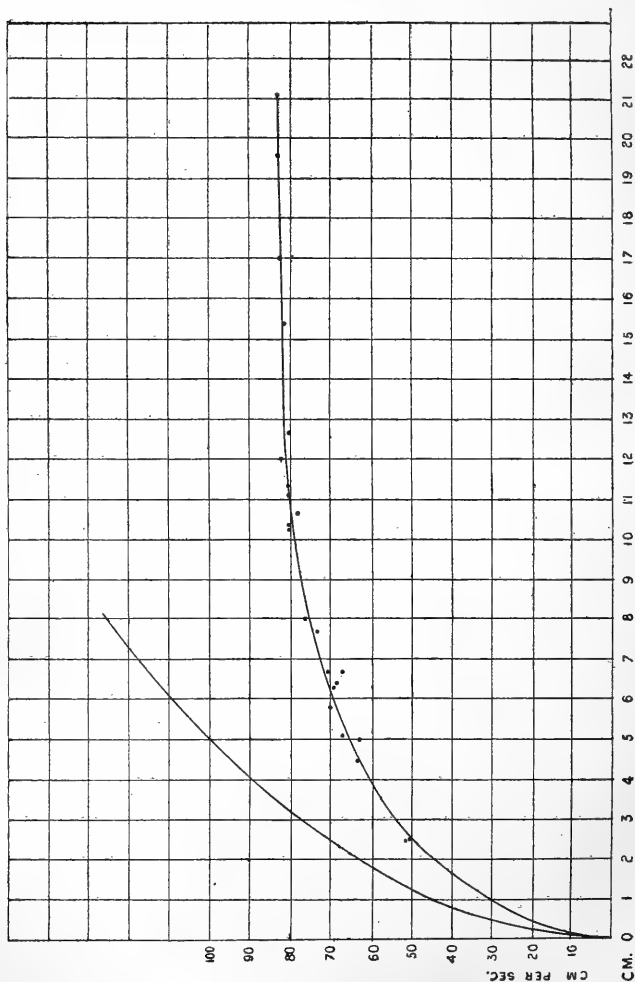

where R represents the resultant upward force due to the pressure of the fluid. If we subtract from R the weight of fluid displaced by the sphere, we obtain the force due to the

motion through the liquid. This will include at least two terms, one arising from the motion in a viscous fluid with velocity V , and the other involving the acceleration of the sphere. As we have no means of separating the effects, we cannot in this way deduce the resistance experienced by a sphere moving with constant velocity through a viscous fluid.

The following values of R were calculated from the curve:—

TABLE VI.

S, cm.	V, cm./sec.	f , cm./sec. ²	R.	$R - \frac{\rho}{\sigma} W.$
3	54.0	415	$\frac{566}{981} W.$	$\frac{441}{981} W.$
5	65.2	294	$\frac{687}{981} W.$	$\frac{562}{981} W.$
7	72.2	227	$\frac{754}{981} W.$	$\frac{629}{981} W.$
9	77.5	151	$\frac{830}{981} W.$	$\frac{705}{981} W.$
11	80.2	75	$\frac{906}{981} W.$	$\frac{781}{981} W.$
Terminal.	83.0	0	W.	$\frac{856}{981} W.$

The rate at which the acceleration falls off increases suddenly when the velocity is about 75 cm./sec. This would seem to show that the law of resistance to the *steady* motion of the sphere employed undergoes a sudden change for this particular velocity.

10. Terminal Velocities of Steel Balls.

In the case of the two smallest balls, the depth of the glass vessel was great enough to allow of the terminal velocity being attained. But for the larger balls it was found necessary to increase the possible height of fall. This was done by allowing the ball to fall through a vertical glass tube filled with water and having its open end beneath the surface of the water in the vessel. In order to suspend the ball from the electromagnet hermetically fitted into the top of the tube, and then fill the latter with water, a circular opening was made in the side of the tube close to the top. Through this opening the ball was introduced. Then the aperture was closed by a rubber bung, through which passed a short tubulure for the purpose of filling the tube by suction

A similar tube for increasing the height of fall was provided for the timing-sphere.

In Plate I. fig. 1, one of these two tubes may be seen supported by a retort-stand, on the extreme left of the picture.

The dimensions of the glass vessel first used were as follows:—length 11·5 centim., width (from front to back) 3 centim., depth 28 centim., all internal measurements. The internal diameter of the tube used to produce a higher fall was 2·4 centim.

An increase in the height of fall from 34 centim. to 46 centim. produced an increase in the velocity of the largest ball of less than 1 per cent. It was therefore assumed that with a fall of 45 centim. (the vertical distance from the electromagnet to the top of the rectangular aperture) all the balls would have practically attained their terminal velocity. The results are given in Table VII., but it should be noted that the velocities of balls V. and VI. were obtained from falls of 23·9 and 21·2 centim., respectively.

The dimensions of the balls are given later in Table VIII.

TABLE VII.
Steel Balls in Water.—Small Vessel.

	Velocity V.	log V.	log α V.	Temperature.
I.	cm./sec. 128·0	2·1073	1·7051	11°·2 C.
II.	121·6	2·0849	1·5864	14·6 C.
III.	116·5	2·0665	1·5114	14·6 C.
IV.	102·3	2·0100	1·3864	14·0 C.
V.	95·4	1·9797	1·2793	18·9 C.
VI.	83·1	1·9194	1·1208	17·8 C.

The object aimed at in the experiments was to approach, as far as practicable, the ideal case of a sphere falling in a fluid of infinite extent. The width of the glass vessel in the experiments already quoted was only four times the diameter of the largest sphere. It might, therefore, fairly be presumed that the walls of the vessel would have considerable influence on the motion of the fluid, and consequently on the velocity of the sphere. In order to test this point, a larger vessel was constructed 11·5 centim. long, 6 centim. wide (from back to front), and 21 centim. deep. A wider fall-tube was

also made 4.5 centim. in diameter. The vessel was connected by a siphon with a large vessel of water, so as to keep the water-level nearly unaltered when this tube was filled by suction.

TABLE VIII.
Steel Balls in Water.—Large Vessel.

	Weight W.	log W.	Radius a .	log a .	Velocity V.	log V.	log aV .	Temp.
	gm.		cm.		cm./sec.			
I....	2.010	.3034	.3961	$\bar{1}.5978$	133.2	2.1245	1.7223	10° 8 C.
II....	1.036	.0153	.3173	$\bar{1}.5015$	126.3	2.1016	1.6031	11° 7 C.
III....	0.7006	$\bar{1}.8455$.2786	$\bar{1}.4449$	120.5	2.0808	1.5257	12° 6 C.
IV....	0.4354	$\bar{1}.6389$.2379	$\bar{1}.3764$	110.5	2.0432	1.4196	12° 4 C.
V....	0.2542	$\bar{1}.4051$.1993	$\bar{1}.2996$	100.5	2.0020	1.3016	11° 4 C.
VI....	0.1316	$\bar{1}.1192$.1590	$\bar{1}.2014$	90.9	1.9586	1.1600	11° 5 C.

The observed velocities are given in Table VIII., which also contains the radius and weight of each ball.

These velocities were all obtained from a fall of more than 34 centim.

A comparison of these results with those already given in Table VII. for the same balls falling in a smaller vessel, shows that the effect of increasing the width of the vessel from 3 centim. to 6 centim. is to increase the velocity by only about 4 per cent. Hence we may fairly conclude that in the larger vessel the circumstances attending the fall do not differ in any material respect from those in an infinite fluid for a corresponding fall, and that even if the velocities could be still further increased by increasing the size of the vessel, the manner in which the velocity depends on the size of the sphere would not be affected.

11. Law of Resistance.

In order to determine from these results the relation between the resistance and the velocity of the sphere, recourse was had to the method of logarithmic coordinates. It has been shown that if the resistance can be represented by a single term, it must be proportional to $(aV)^n$.

The values of $\log aV$ were calculated and employed as ordinates, while the abscissæ were given by the values of $\log W$, since for spheres of the same density the resistance is

proportional to the weight. It was then found that save for the largest sphere the points lay almost exactly on a straight line (fig 4)*.

The slope of the straight line on which the observed points fall determines the value of n . The straight line drawn in the diagram is that line passing through the point VI., for which $n=2$. Hence it appears that *the resistance is proportional to the square of the velocity.*

Referring to § 3 we obtain

$$R = k\rho a^2 V^2,$$

indicating that the resistance to the steady motion of a sphere with velocity V is independent of the viscosity of the fluid.

It should be borne in mind that this does not imply that equal spheres moving with the same velocity in two liquids, one of great the other of small viscosity, necessarily experience the same resistance. For in the more viscous liquid the sphere will require a greater velocity before the régime indicated by the above law can be entered upon.

The exceptional case of the largest sphere presents some difficulty. The observed values of $\log aV$ fall short of those required by the assumption of a resistance proportional to the square of the velocity. It is scarcely possible to suppose that any higher power than the square could be involved, for this would necessitate a resistance *decreasing* with increasing viscosity.

Perhaps the simplest explanation is to be found in the supposition that the influence of the walls of the fall-tube and vessel has become appreciable in the case of this sphere, which possesses the greatest diameter and the greatest terminal velocity.

In this connexion it is interesting to recall a remark of Sir I. Newton in a discussion of experiments on the resistance experienced by a pendulum oscillating in water. "I found (which will perhaps seem strange) that the resistance in the water was augmented in more than a duplicate ratio of the velocity. In searching after the cause I thought upon this, that the vessel was too narrow for the magnitude of the pendulous globe, and by its narrowness obstructed the motion of the water as it yielded to the oscillating globe" (Mathematical Principles of Natural Philosophy, Book II. Sect. vi.).

Assuming that $n=2$ we can determine the value of the

* In the diagram (fig. 4) observations in the small vessel are indicated by crosses, those in the large vessel by points. The latter are the more reliable (see § 8).

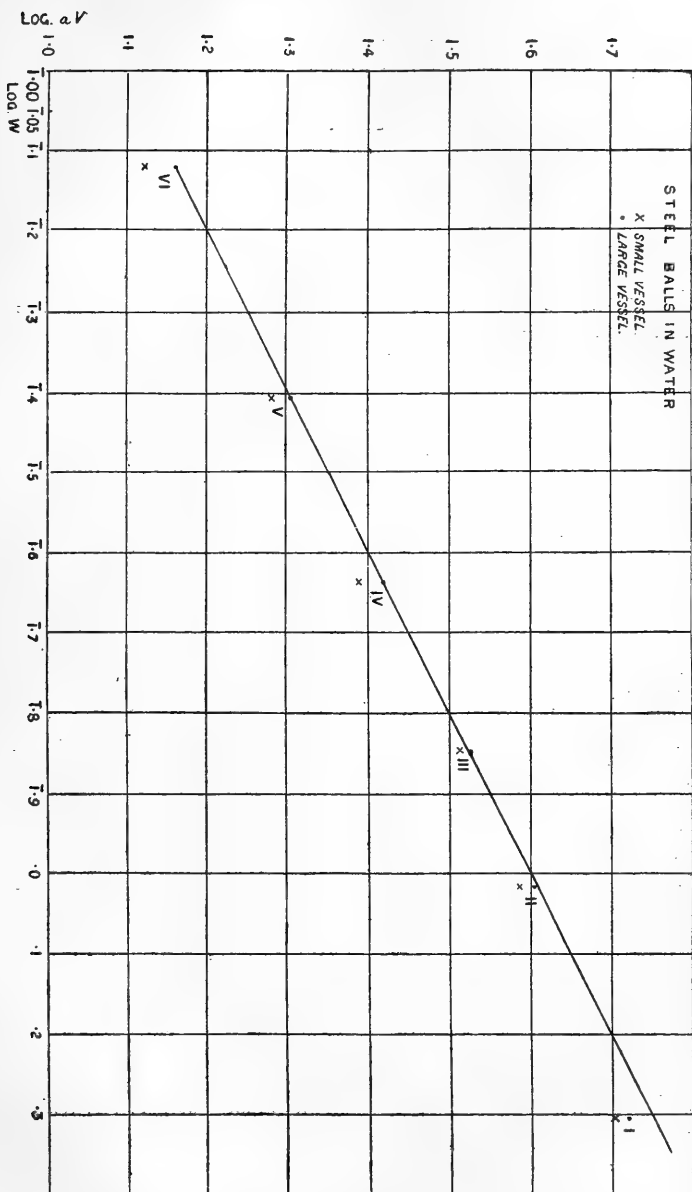

Fig. 4.

constant k in the relation

$$R = k\rho a^2 V^2;$$

for if W is the actual weight of a sphere,

$$R = \frac{\sigma - \rho}{\sigma} W,$$

and so

$$\log k = \log W + \log \left(\frac{\sigma - 1}{\sigma} \right) - 2 \log aV.$$

The mean density of the steel balls was found to be 7.731.

The values of k for the spheres, excepting the largest, are the following :—

II.	5.61×10^{-4} .
III.	5.42×10^{-4} .
IV.	5.49×10^{-4} .
V.	5.52×10^{-4} .
VI.	5.48×10^{-4} .
Mean	5.50×10^{-4} .

The formula giving the terminal velocity will be

$$k\rho a^2 V^2 = \frac{4}{3}\pi g(\sigma - \rho)a^3$$

$$V^2 = \frac{1}{k} \cdot \frac{4}{3}\pi g \frac{\sigma - \rho}{\rho} \cdot a.$$

R. S. Woodward* has made a preliminary series of experiments on metallic spheres falling in water. Spheres of steel, silver, aluminium, and platinum were dropped in a tube of water 16 feet long and 1 foot in diameter. The spheres varied in diameter from one inch to two inches. All the spheres acquired a constant velocity inside of the first metre. Newton's law † that resistance to motion is proportional to the square of velocity seemed to be verified. The times of falling were determined with a chronoscope.

No further details have yet been published.

* Trans. New York Acad. Sci. xv. p. 2 (1895).

† "But, yet, that the resistance of bodies is in the ratio of the velocity, is more a mathematical hypothesis than a physical one. In mediums void of all tenacity, the resistances made to bodies are in the duplicate ratio of the velocities. For by the action of a swifter body, a greater motion in proportion to a greater velocity is communicated to the same quantity of the medium in a less time; and in an equal time, by reason of a greater quantity of the disturbed medium, a motion is communicated in the duplicate ratio greater; and the resistance is as the motion communicated."—Newton, 'Mathematical Principles of Natural Philosophy,' Book II. Scholium.

Newton's own experiments on the resistance experienced by falling spheres are described in Sect. VII. of the same Book.

12. *Fall of an Oiled Sphere.*

The photograph reproduced in Plate II. fig. 4 is of special interest since it shows the fall through water of a sphere oiled with Rangoon oil. It will be noticed that the greater portion of the oil has collected on the upper surface of the sphere, forming as it were a "tail" that follows the sphere in its downward motion. The velocity of the oiled sphere found from this photograph was 114.5 centim. per sec., as compared with 120.5 centim. per sec. for the same sphere unoled. The effect of oiling the sphere has therefore been to reduce the velocity by 5 per cent.

No sensible change has been produced in the diameter of the image, so that practically all the oil must be collected in the tail. The volume of the tail is roughly estimated at .0034 cub. centim. : the total volume of oil descending with the sphere must certainly be less than .005 cub. centim. The approximate weight of the ball is .70 grm., and its volume .090 cub. centim., the density being about 7.8. The mean density of the oiled sphere, taking the upper limit for the volume of the oil, would be 7.2. The change in density would therefore be sufficient to account for the observed reduction in the velocity, so that it is not necessary to assume any change in the general character of the fluid motion.

13. *Summary and Conclusion.*

The experiments described in this paper have had for their object the measurement of the terminal velocity attained by a spherical body falling freely in a viscous fluid. From these measurements it was desired to deduce the law of resistance, and also to obtain information as to the existence of "slipping" at the boundary of a fluid mass moving in a fluid of different density.

With regard to the latter point, the experiments made on the velocity of ascent of small air-bubbles in water and aniline, show that the velocity acquired is the same as would be attained by a solid sphere of corresponding density and dimensions. No appreciable slipping has been detected in the case of a solid in contact with a liquid. We may therefore extend this conclusion to the case of two different fluids in contact.

It has also been shown that the law of resistance to the motion of a sphere moving with constant velocity in a viscous fluid depends on the magnitude of that velocity. Three distinct stages have been recognized.

(1) When the velocity is sufficiently small the motion

agrees with that deduced theoretically by Stokes for non-sinusoidal motion on the assumption that no slipping occurs at the boundary. In such motion the resistance is proportional to the velocity.

(2) When the velocity is greater than a definite critical value, the terminal velocity of small bubbles and solid spheres is proportional to the radius less a small constant; it may be expressed by the formula

$$V = k \left(\frac{\rho - \sigma \cdot g}{\rho} \right)^{\frac{2}{3}} \frac{a - h\bar{a}}{v^{\frac{1}{3}}},$$

where $k = \frac{1}{2}$ and $h = \frac{2}{3}$ approximately.

This would indicate a resistance varying as the velocity raised to the power of three halves.

(3) For velocities considerably greater than those just considered the law of resistance is that which Sir I. Newton deduced from his experiments, namely, that the resistance is proportional to the square of the velocity. The resistance is, in fact, given by the expression

$$R = k\rho a^2 V^2.$$

In discussing the resistance during the accelerated part of the motion, we found indications of a somewhat sudden change in the law of resistance to steady motion. This change may correspond to the passage from stage 2 to stage 3 above.

In conclusion I beg to express my thanks to Professor J. J. Thomson for placing the resources of the Cavendish Laboratory at my disposal, and for his suggestions and advice in the course of the work.

Trinity College, Cambridge.

LI. *Notices respecting New Books.*

Grundriss der Allgemeinen Chemie. Von W. OSTWALD. Leipzig: Wilhelm Engelmann, 1899. Pp. xvi+549.

THE appearance of a new and revised edition of this standard text-book will be welcomed by all students interested in the subject. It is a masterly exposition by one who has himself contributed in no small measure to the development of this comparatively recent branch of science.

The book is divided into two parts. Part I. is subdivided into six sections, each section consisting of several chapters. Section 1 deals with the fundamental laws of physical chemistry, the elements and their laws of combination, and the periodic law. Section 2 is devoted to the laws of gases and the kinetic theory. In section 3 are considered the general properties of liquids, the phenomena of evaporation and condensation, the thermodynamics of liquids, their behaviour with respect to light, and the phenomena of surface-tension and viscosity. Section 4 deals with solids, crystallization,

liquefaction and solidification, isomorphism and polymorphism. Section 5 treats of dilute solutions, osmotic pressure, diffusion, and the phenomena connected with the vapour-pressure and the freezing-point of solutions. Section 6 deals with the periodic law of the elements, the molecular theory, and the theory of valency. Part II., which is devoted mainly to a consideration of the energetics of the various chemical processes, embraces the remaining five sections of the book. In section 7 is considered the important subject of thermo-chemistry. This is treated somewhat fully, and a large collection of useful numerical data is given. Section 8 deals with chemical equilibrium. Electro-chemistry forms the subject of the next section; section 10 is devoted to photo-chemistry; and the concluding section 11 deals with chemical affinity.

Although the book professes to be only an outline of the subject, it contains an enormous amount of information in a condensed form, and should prove extremely useful as a book of reference to the student of physics as well as of chemistry. A good example of the extremely conscientious and thorough manner in which the author has fulfilled his task is afforded by chapter 3 in the first section of the book, which deals with the combining weights of the elements. Not only is there a table given of the atomic weights according to the most recent determinations, but there is a full account of the various methods by means of which the atomic weights of the different elements have from time to time been determined, the date of each research and the name of the investigator being given. Similar thoroughness of treatment characterizes most sections of the book.

Among its many noteworthy features may be mentioned the adoption throughout of a system of units based directly on the C.G.S. system. Thus, in the section on thermo-chemistry, the joule and kilojoule are adopted as heat units, and the author has gone to the trouble of re-calculating the large mass of data relating to this subject, and expressing them in terms of the kilojoule. It is earnestly to be hoped that in future other writers will follow this lead, and thereby help to remove all unnecessary complexity surrounding this subject.

The clear way in which the author arrives at many of the fundamental conceptions of chemistry as a direct result of experimental investigation, and without calling in the aid of particular theories, such as the atomic and molecular theory, is highly to be commended, and is well worthy of very close study by all teachers of the subject.

In a work of such general excellence, it is somewhat of a surprise to come upon the slovenly treatment of Ohm's law on p. 377. After giving a definition of resistance, the author writes down the symbolical equation corresponding to the definition, and immediately afterwards states that "this is the celebrated law of Ohm!" As if a mere *definition* could constitute a *law*! In so doing, however, the author is only following the traditionally inadequate treatment of this subject. Surely it is quite as easy,

after giving the definition of resistance, to state that the quantity so defined is, for a given conductor maintained under given physical conditions, independent of the current. It is this constancy of the resistance which is an experimentally verifiable and experimentally verified fact, and which constitutes the essence of Ohm's law.

LII. *Proceedings of Learned Societies.*

GEOLOGICAL SOCIETY.

[Continued from p. 444.]

June 6th, 1900.—J. J. H. Teall, Esq., M.A., F.R.S., President, in the Chair.

THE following communication was read:—

1. 'Mechanically-formed Limestones from Junagarh and other Localities.' By Dr. J. W. Evans, LL.B., F.G.S.

After reviewing the conditions under which granular limestones may be accumulated by current- or wind-action, the author proceeds to describe the limestone of Junagarh, a deposit some 200 feet thick, resembling in hand-specimens the Oolites of this country, though less firmly cemented together. It is mainly formed of grains consisting of a nucleus of a fragment of a marine organism or foraminiferal test, surrounded by a layer of deposited carbonate of lime. Particles derived from the igneous rocks of the neighbourhood and rounded quartz-grains also occur, but amount to only a small percentage of the rock. The whole is bound together by colourless calcite-cement. The deposit is situate at a distance of 30 miles from the sea, and contains no large fossils of any kind.

Calcareous rocks of similar character are described from other parts of Kathiawar, Kach, the south-eastern coast of Arabia, and the Persian Gulf—some of these contain unbroken marine shells and other fossils. These beds are included by Dr. H. J. Carter under the name of miliolite, on account of the frequent presence in them of the genus *Miliola*.

The author discusses the origin of these deposits, and comes to the conclusion that the grains were formed in sea-water saturated with carbonate of lime: some being deposited by currents in shallow water, and others thrown up as a calcareous beach, from which a portion were sifted out by the wind and blown inland to form æolian deposits, as contended by Prof. Blake in the case of certain superficial limestones in Kach. The Junagarh limestone falls into the last group, but must have been formed when the land was at a low level and the sea-shore was at no great distance.

A rapid survey is then taken of similar rocks in other parts of the world, which may be grouped into the same three classes. The remarkable wind-blown foraminiferal deposit of Dog's Bay (Galway) is referred to in some detail; and the author concludes by suggesting that in the Oolites of the Jurassic period we have representatives of all three groups.

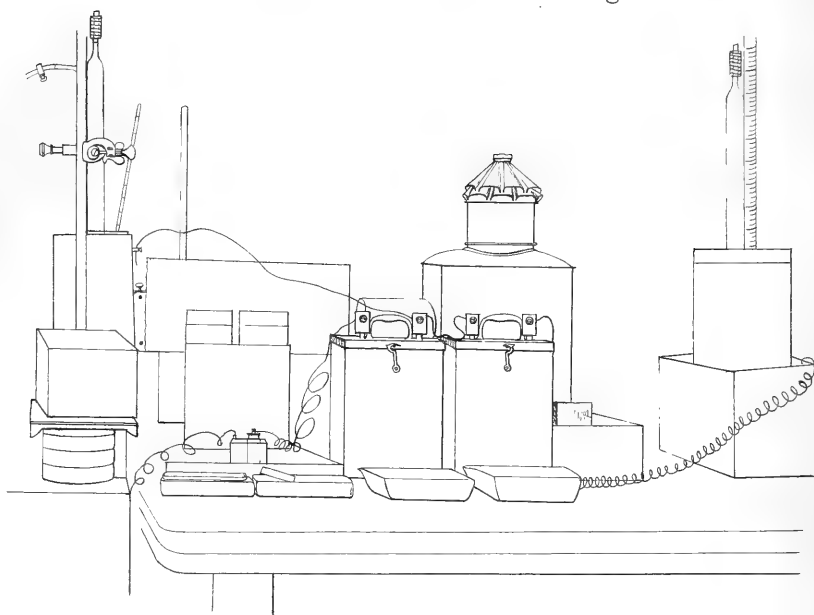

Fig. 1.

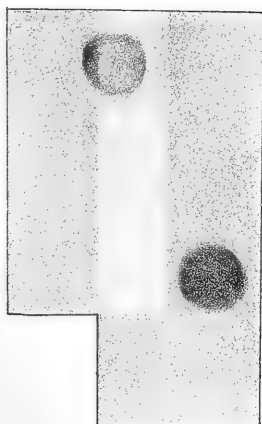

Fig. 2.

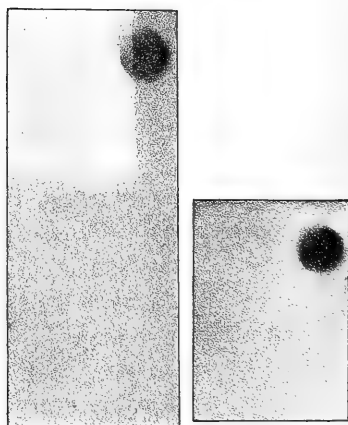

Fig. 3.

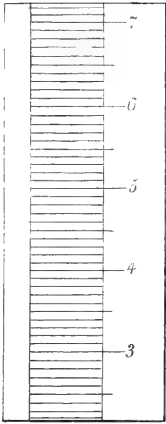

Fig. 1.

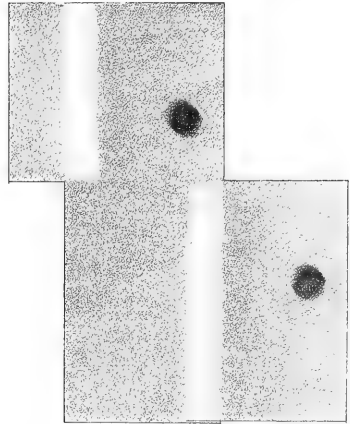

Fig. 2.

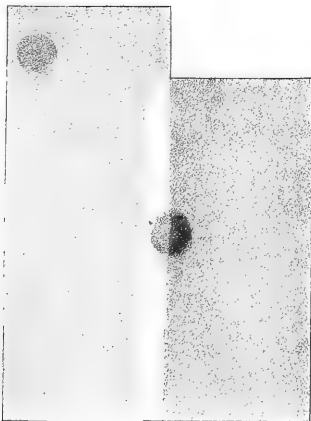

Fig. 3.

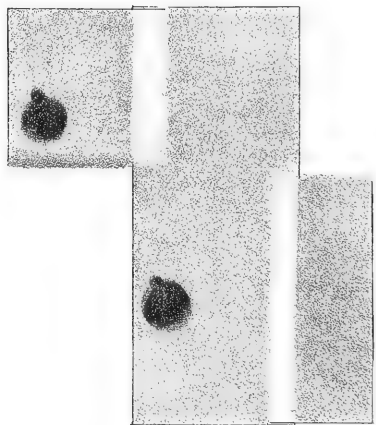
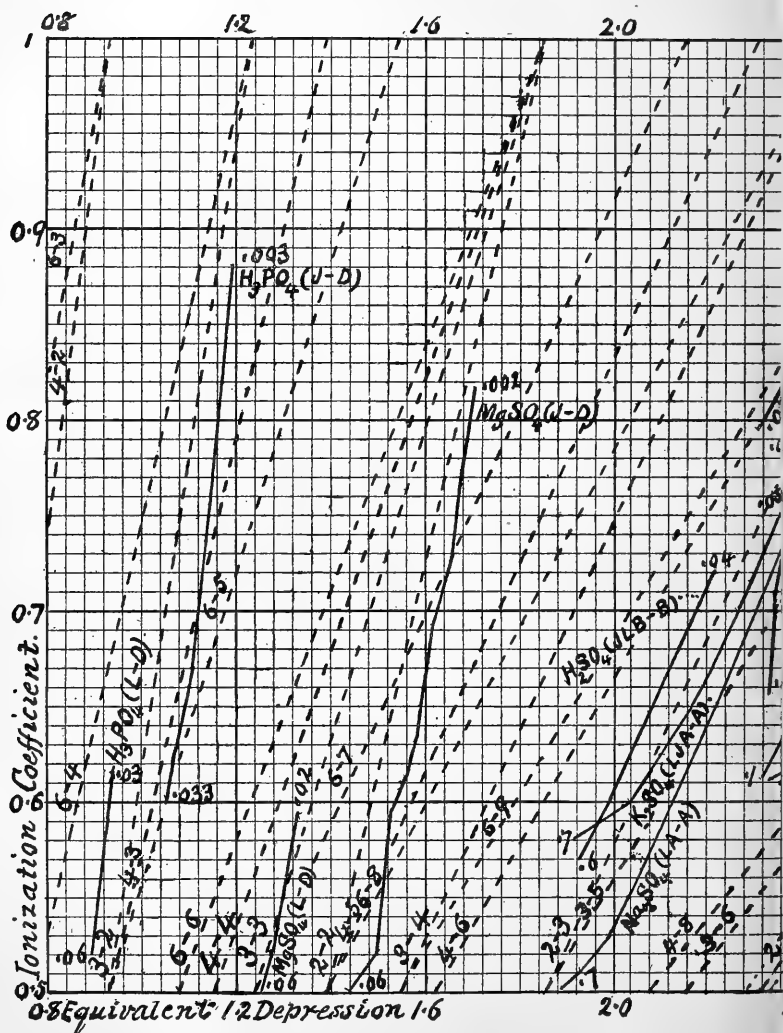
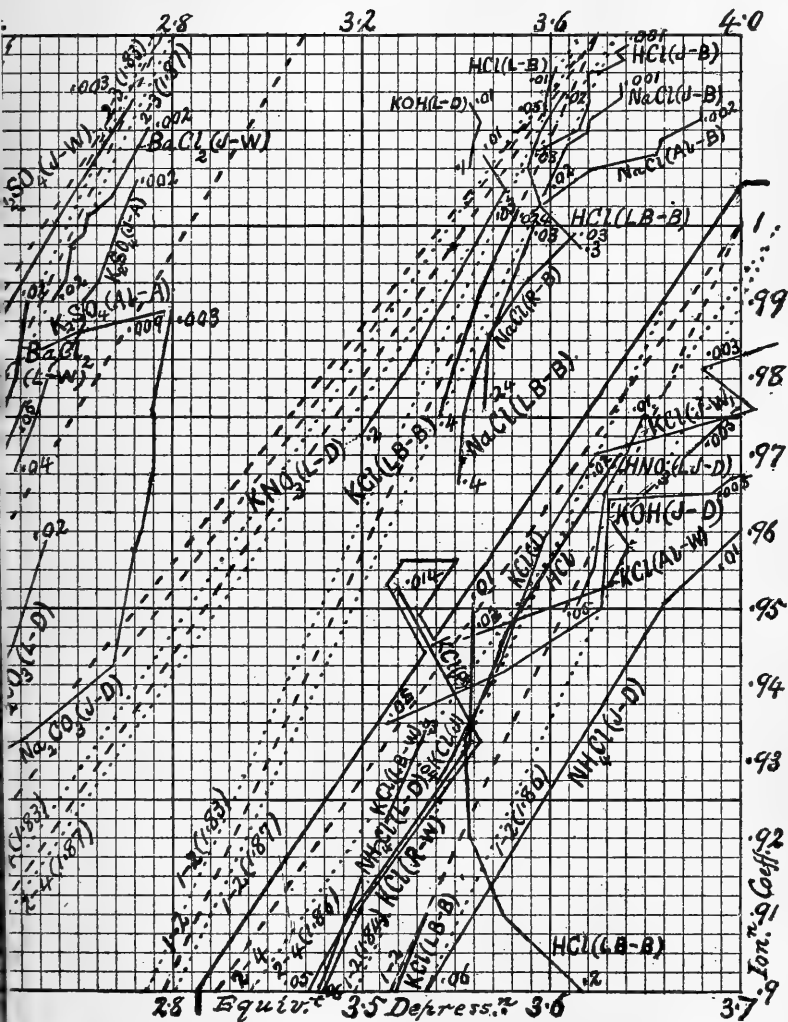

Fig. 4.



0.8 Equivalent 1.2 Depression 1.6

2.0





THE
LONDON, EDINBURGH, AND DUBLIN
PHILOSOPHICAL MAGAZINE
AND
JOURNAL OF SCIENCE.

[FIFTH SERIES.]

DECEMBER 1900.

LIII. *An Electric Micrometer.* By PHILIP E. SHAW,
B.A., B.Sc., Lecturer in University College, Nottingham*.

PRELIMINARY.

IN the summer of 1897, I was engaged in investigating some of the conditions which conduce to high efficiency and stability in a telephone system.

The ultimate product of the system is, of course, vibration of the receiver-diaphragm; so that, *ceteris paribus*, any change in the apparatus, or connexions, which produces increased amplitude of that diaphragm, makes for efficiency.

Suppose now, for instance, that the winding of the receiver-electromagnet is altered, then, passing in constant sound to the transmitter, if we measure the movement of the receiver-diaphragm before and after any such change, we shall be able to judge of the efficacy of the change.

Such was the idea that led to the making of the measuring arrangement to be described, which has proved to be suitable both in delicacy and adaptability for diaphragm movements.

I. EXPERIMENTAL METHODS.

1. *Apparatus.*

First Form.—The principle employed is to measure the exact place of contact of two surfaces which, on meeting, complete a circuit containing a telephone. A special spherometer was made with great care; the disk was 8 cm. in diameter, graduated

* Communicated by the Physical Society: read March 23, 1900.
Phil. Mag. S. 5. Vol. 50. No. 307. Dec. 1900. 2 Q

into 500 parts, the screw-pitch was $\frac{1}{2}$ mm.: the graduations were subsequently corrected against dead-hard pieces of steel 5, 10, 15, &c. mm. long, verified by the Standards Department of the Board of Trade, the errors being very small.

The three outer legs of the spherometer were removed and the frame (AB) of the spherometer was fastened firmly to the thick board (XX) (fig. 1), then the end of the screw (S)

Fig. 1.

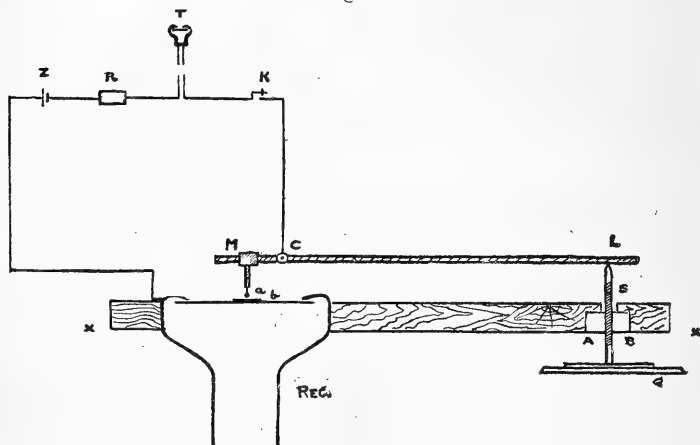

abutted against the long arm (CL) of a lever which was held against it by a spring, while the short arm (CM) carried a small brass rod holding in its end a platinum wire beaded at the end (a).

The telephone-receiver (*Rec*) is firmly fastened in the board (XX) so that the centre of the diaphragm, which carries a small platinum plate, is opposite to the platinum bead. Then the circuit, consisting of the cell (Z), the resistances (R), the observing-telephone (T), the key (K), and the contacts, is completed when (a) and (b) meet, which can be brought about by a forward or backward movement of the screw (S).

As seen in the figure, the graduated disk (G) has a pulley on the back of it; a cord passes round this and a series of other pulleys, so that the screw can be worked to and fro by the observer without touching the screw directly by hand. By the use of the pulley-string, vibrations are not so readily transmitted from the hand, and, moreover, by that means the observer can work from a convenient distance, reading the disk (G) by a telescope.

The telephone (T) has long flexible wires, so that the

observer can have it attached to his head and hear the contact made, while at the same time he is watching the disk (G) for its position. In this manner the position of the "break" of contact (*a*) and (*b*) can be observed.

Suppose now a steady current passes in the receiver (*Rec*), the diaphragm will move to a new position and remain there; then the observer can quite easily follow, and measure, its movement.

The wooden frame carrying the apparatus was heavily weighted with lead and supported on soft rubber balls, to insulate it against vibrations.

The ratio of the lever-arms was about 10 : 1. By using a telescope, each graduation on the disk (G) could be divided by eye into ten parts; each of these corresponded to a movement of the screw-end of $\frac{1}{50000}$ of $\frac{1}{2}$ mm., or 10^{-5} cm., or at the other end of the lever to 10^{-6} cm. about.

*Second Form**.—In the next attempt (fig. 2, p. 543), the single brass lever was replaced by three levers of aluminium, working in co-operation, so that the joint leverage ratio could be made 1000 : 1.

The levers are made of aluminium bar ($\frac{1}{4}$ in. \times $\frac{1}{2}$ in. section) about 15 inches long; the pivots are of steel, their ends being pointed to rather acute cones. The lower bearings for the lever-pivots are provided in brass plates let into brackets, whilst the upper bearings are turned in the screw-ends. The brackets which carry these top bearings are made of stout brass bar, bent twice at right angles and firmly screwed to the frame and to the wooden brackets.

The screws mentioned before have lock-nuts bearing on the brass brackets so that the pivots can be tightened up in their bearings as required. Each lever is balanced by a lead weight screwed to its short arm, the object being to have the centre of gravity of each lever over the lower bearing so as to have no side pressure and consequent wearing of the upper and lower bearings. The lever-ends are kept firmly in contact with their bearings by the action of the helical brass springs attached to the levers and to the frame; these springs are fairly strong, so as to render the pressure throughout the lever-system firm and reliable in all positions.

This point is of obvious importance, for any backlash in the screw or looseness of the pivots in their bearings, would be nullified by the action of the springs; so that we should still have firmness in the lever-system.

The bearings by which the ends of the second lever press on the other two are moveable, so that we can obtain different

* Exhibited at the Royal Society Conversazione on May 8, 1900.

leverages by clamping them in different positions. The greatest leverage thus obtainable was about 1000:1, and the least about 100:1. A centimetre-scale was marked on the levers, so that the clamps could be brought to any desired position as often as required.

The arrangement for holding the telephone-receiver, on which the experiments are made, will be described next.

There is a massive hollow cylinder of wrought iron 15 cm. long, 9 cm. diameter, the metal being about $\frac{1}{2}$ cm. thick. The telephone-receiver is screwed to a ring on the further side of the cylinder, so that, on looking from the back, the whole diaphragm may be seen. There is also a screw cut on the outside of the cylinder, which works in a screw cut in a ring of iron, imbedded in, and screwed to, the wooden frame.

A lock-nut is provided so that when the cylinder has been screwed into position it may be tightened and held rigid.

By having such a massive and well-fitting support for the receiver, firmness and ready adjustability are secured for it.

Having briefly described the essential parts of the apparatus, we now proceed to consider the various adjuncts separately.

2. Supports.

The table is supported from the foundation of the building by brick piers. Vibrations passing through to the table would be mostly of high frequency, and so should not be transmitted by a succession of heavy masses separated by springs and layers of indiarubber. The series was as follows:—(1) Blocks of solid pure rubber on the table; (2) a lead slab of 180 lb.; (3) four soft rubber balls; (4) a board weighted to 50 lb.; (5) four soft rubber balls; (6) the large rectangular frame loaded from which hang (7) four rubber springs which hook on to (8) the apparatus, which is loaded to about 50 lb.

The above provisions against tremors were sufficient for the most delicate work, provided that no violent vibrations were started in the neighbourhood. The motion of carts in the streets, violent wind-gusts, or the working of near factory-machinery were fatal.

An attempt was made to find roughly the efficiency of the various layers in the series, as follows. I found the vibration amplitude in the apparatus (1) when all the layers were in, (2) when the upper one was removed, (3) when two were removed, and so on. By actual measurement the amplitudes were found to be roughly (using $\mu\mu$ as unit):—

1, . . . 10, . . . 15, . . . 40, . . . 100;

i. e., (1) when the apparatus was suspended from the door-springs the amplitude was $1\mu\mu$; (2) when the apparatus was unhooked from the springs and rested on the other layers, we had $10\mu\mu$, and so on.

The above measurements show that solid rubber is more useful than the hollow rubber balls (whose elasticity depends greatly on compressed air), and also that little advantage is obtained by the second layer of balls.

3. Covers.

Temperature-changes in the levers, and contacts, may arise in many ways, but especially from draughts of air and radiation.

To provide against these, and also against moving dust in the air, different wooden covers were placed over (1) the contacts, (2) the levers, (3) the telephone-receiver and its enclosing metal cylinder. After some trial these precautions were found inadequate; so the whole apparatus was wrapped in thick felt. This covering served well, not only in maintaining a constant temperature but also in damping sound-vibrations, which in some cases, before its application, produced a chattering of the contact of about the frequency of the sounds themselves. By taking such extensive precautions, immunity from these disturbances was obtained, even in the extreme case when very many gas-jets were burning in the room.

As regards dust, it was anticipated that great trouble would arise, for even small particles suspended in the air would be large compared to the smallest distances to be measured by the apparatus: such particles would seem likely to remain suspended in the air about the contacts, even after the covers had been put on and the air had remained calm for a long time. Also we might suppose that the contacts, being electrically charged, would be centres of dust collection, so that in fact we should have a clogging of the contacts from dust, just where it was desirable that they should be specially clean.

To avoid these baneful effects, a special atmosphere round the contacts was provided; air was driven at a uniform rate through sulphuric-acid bottles, then through cleaned cotton-wool, then through a helical tube in a water-bath, then into the compartment containing the contacts. It was hoped that the contacts would thus have round them dry and dust-free air of uniform temperature. But this plan was soon abandoned, for this special air was found to produce comparatively rapid and great temperature-fluctuations at the contacts; so that

the air-temperature was much more steady before than after the "remedy" was applied.

The best plan, therefore, seems to be to give the chamber containing the contacts time to settle to its own state of temperature-equilibrium after the covers are on.

What part, if any, dust really plays, the author has not ascertained, for in all the later work it has been left out of account.

4. *Contacts.*

Platinum was first used for both contacts; but as there seemed to be a slight permanent yielding of the surfaces even under the very small pressures used, iridio-platinum (20% iridium) was substituted for it and used generally afterwards. The iridio-platinum plate (4 mm. square) used was soldered to the surface of the iron diaphragm of the receiver, care being taken to use a small soldering-iron so as to avoid great heating and consequent buckling of the diaphragm.

It was found requisite to clean the contacts thoroughly and often, so as to keep them in good working order. When the two surfaces are quite right, the sound heard at "make" and "break" is sharp, and has a clear ring; but when not in good order a dull or "wheezy" sound is heard, which may in some cases continue over a distance of as much as 10^{-5} cm.; evidently in such a case the contact is only partial over this distance.

On consideration, it will be seen that this disorder may be due to dust or oxide or other impurity on the surfaces; but conceivably it might be attributed to a gradual grazing contact made between two projecting parts of the surfaces, so that contact is not complete till the contacts are pressing one another appreciably.

Whatever the cause, this state of the contact must be removed. In some cases it suffices (1) to press together and release the surfaces several times in succession; (2) to make and break current several times when the surfaces are in contact; (3) to rub the surfaces (*in situ*) with some clean tape. But it often happens that all such ready means fail: then the contacts must be dismounted, polished, and cleaned as follows:—

Place each contact in turn in the lathe, (1) rub with the the finest emery-paper, (2) polish with rough paste, (3) polish with fine paste, (4) rub with caustic potash and wash, (5) rub with hydrochloric acid and wash and dry, (6) rub well with clean tape. A clean surface having very small roughnesses should be the result of this process.

It would seem desirable to produce the highest possible polish, for doubtless the irregularities on the surfaces, even under the best conditions, are large compared with the smallest measurements to be made. The ideal surfaces would be a geometrical sphere and geometrical plane, whereas the actual contacts would, if very closely examined, appear in point of roughness more like mountainous regions.

5. Circuits.

The simple circuit, shown in plan in fig. 1, was superseded by one shown (also in plan) in fig. 2, where we see the observing-receiver (*Rec*) and a condenser (*S*) put together as a shunt to the large resistance (R_1). Another, small, resistance (R_2) is used, and the cell (*C*) can be reversed.

Fig. 2.

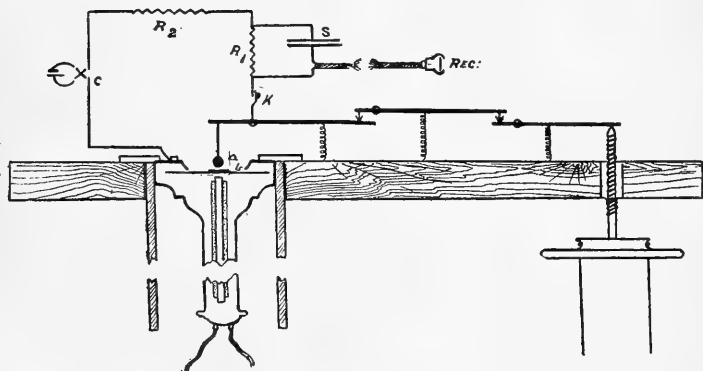

If the circuit is completed by the touching of the contacts (*a, b*), there is (1) a momentary rush of electricity to charge the condenser, (2) a steady current of small amount through the resistances R_1 and R_2 . (1) soon ceases. On "breaking" circuit, by the separation of *a* and *b*, the condenser will be discharged through R_1 , and so, at the next "make," will receive a new charge, and so on.

Thus at both "make" and "break" a rush occurs through the telephone (*Rec*), giving the observer evidence of them; the rush lasts for a very short time, but it can be made powerful enough to serve our purpose.

By the use of a condenser we obtain a large impulsive flow just when required, *i. e.* at "make" and "break;" hence the contact is not disturbed by a steady flow (and consequent heating &c.) during the interval between make and break.

A simple example will show the value of this method. Consider two cases:—

- (1) $S = 0.1$ mfd.
 $R_1 = 10,000,000 \omega$.
 $R_2 = 1000 \omega$.
 E.M.F. = 1.0 v.

Then, neglecting the small steady current, the quantity passing impulsively at make is

$$Q = 0.1 \times 10^{-6} \times 1.0 = 10^{-7} \text{ coulomb.}$$

- (2) Suppose we used a simple circuit as in fig. 1:—

$R = 100,000 \omega$ (this is the most attained in practice).
 E.M.F. = 1.0 v.

Then the quantity passing during 1 second after make would be:—

$$Q = 10^{-5} \times 1.0 = 10^{-5} \text{ coulomb.}$$

This is 100 times as large as for case (1); and if the surfaces were in contact for more than 1 second, the ratio would be even larger.

The plan in working is to reduce S and increase R_1 and R_2 down to the limit of comfortable sounding of the receiver. By this care the surfaces can be used continuously for 2 to 8 hours, whilst when not in use they seem to remain unchanged.

Suppose that by the passage of electricity at the contact the platinum wire rose in temperature $\frac{1}{100}$ of one degree, it would if 1 cm. long expand about 10^{-7} cm., *i. e.* one of our smallest measurements. Hence it is that large currents are to be deprecated.

6. *Setting the Contacts.*

Suppose the apparatus set up, and the contacts clean, and that we wish to get the contact position ready for taking measurements. The observer arranges the observing telephone (which is provided with long flexible wires) on his head, puts on the cells used, and goes to the left-hand of the apparatus (fig. 2). He then screws up the iron cylinder with its receiver till contact is heard, then he tightens the lock-nut till, on gently tapping, the contact is heard to rattle; then he is sure that the surfaces are approximately near one another and, probably, not touching. Then he puts on the cylinder cover and all other covers, and takes a seat at the right-hand end of the apparatus, where, by the motion of the pulley, he can obtain the exact contact position, and observe the graduated disk with the telescope.

In the earlier observations, when the distance was required between any two positions, they were both read and entered (say for instance 48·92~49·43, diff. = 0·51), but subsequently readings were entered always as differences; this method was less tedious and conducive probably to greater accuracy.

II. OBSERVATIONS AND RESULTS.

Passing now to the experimental results we have them arranged as follows:—

- (1) Preliminary.
- (2) Calibration of the instrument.
- (3) Measurement of the diaphragm movement throughout the range of sound impulses, from the smallest audible ones to such as are very loud.
- (4) The damping of the diaphragm.

(1) *Preliminary.*

It was necessary at the outset to ascertain whether this contact method was delicate and consistent, and if so under what conditions. Several months were occupied in endeavours to obtain consistent readings of the contact position of the diaphragm; detail after detail was improved in the apparatus as its requirements were discovered. Three tables will be given as samples of the readings taken.

Table I. explains itself (p. 546).

Table II. shows how the displacement of the diaphragm due to a steady current is taken. Column 2 gives the diaphragm position before, and column 4 after current is put on. Column 3 is found by assuming the creep in contact uniform. Column 7 shows the movement in terms of the unit $\mu\mu$ (10^{-7} centim.). This table was obtained in earlier work, and it is not specially accurate, but it serves to show that the readings are very fairly consistent.

Table III. Here a measurement was made of the throw of the diaphragm; the electromotive force and resistance used are known, but, on account of self-induction in the receiver, the current does not rise at once to its full amount. It is this uncertainty about the action of self-induction which has precluded the use of the throw in subsequent work.

TABLE I.

Consecutive Readings showing the constancy of the contact-position under favourable conditions, and also to prove the small difference that exists between "make" and "break" under certain conditions. The last column gives the difference, if any, roughly in terms of the unit 10^{-7} cm.

That the readings are so very steady as a whole is due in great measure to the fact that they were taken in the late afternoon, when the temperature in the room was nearly stationary.

July 30th. Time.	Make.	Break.	Difference. 10^{-7} cm.		July 30th. Time.	Make.	Break.	Difference. 10^{-7} cm.	
5.34	40.6	40.7	0.1	(10)	6.4	40.7	40.6		
5	40.9	40.9			5	40.6	40.7		
6	40.9	41.0	0.1	(5)	6	40.65	40.8	0.15	(15.5)
7	40.85	40.9	0.05	(10)	7	40.6	40.7	0.1	(10)
8	40.7	40.7			8		
9	40.7	40.7			9		
40	40.8	40.8			10		
1	40.5	40.6	0.1	(10)	1	} Interruption.	
2	40.9	41.0	0.1	(10)	2		
3	41.0	41.0			3		
4	40.7	40.9	0	(21)	4		
5	41.1	41.1			5	40.6	40.7	0.1	(10)
6	40.95	40.95			6	40.8	40.8		
7	41.0	41.0			7	40.6	40.7	0.1	(10)
8	40.8	40.8			8	40.7	40.7		
9	40.8	40.8			9	40.65	40.75	0.1	(10)
50	40.8	40.8			20	40.7	40.7		
1	40.9	40.9			1	40.8	40.8		
2	40.9	40.9			2	40.9	40.9		
3	40.9	40.9			3	40.8	40.8		
4	40.7	40.7			4	40.5	40.5		
5	} Interruption.		5	40.3	40.3		
6			6	40.5	40.5		
7	40.7	40.7			7	40.7	40.7		
8	40.7	40.7			8	40.55	40.55		
9	40.7	40.7			9	44.55	40.55		
6.0	40.8	40.8			30	40.6	40.65	0.05	(5)
1	40.7	40.7			1	} Interruption.	
2	40.7	40.7			2	40.9	41.1		
3	40.8	40.8			3	40.8	40.8		

Thus during the whole of one hour the highest reading was 41.1, and the lowest 40.3, the difference being only 8×10^{-6} cm.

TABLE II.

Consecutive Readings showing that the Diaphragm may be relied on to give uniform readings, when subject to repeated displacement and return. The steady creep in readings seen in column 2 is due to fall in temperature.

Aug. 12th. Time.	Normal Contact.		Displace- ment Contact.	Move- ment.	Mean.		Current &c.
	Observed	Assumed.			Actual.	10^{-7} cm.	
6.12	2.10	}	{ 1.430 V. 10,000 ω .
3	2.00		
4	1.95	1.80	0.15	0.145	15.1	Direct.
5	1.87	1.73	0.14			
6	1.80	} 1.68	1.85	0.17	0.160	16.6	Reversed.
7	1.75		1.82	0.15			
8	1.67	1.82	0.15	0.155	16.1	Direct.
9	1.56	1.20	0.18			
20	1.56	} 1.38	1.20	0.18	0.155	16.1	Direct.
1	1.50		1.27	1.14			
2	1.27	1.14	0.13	0.180	18.7	Reversed.
3	1.20	1.12	0.19			
4	1.20	} 0.97	1.14	0.17	0.180	18.7	Reversed.
5	1.05		0.83	0.19			
6	0.83	1.12	0.19	0.155	16.1	Direct.
7	0.75	0.45	0.15			
8	0.75	} 0.60	0.45	0.15	0.155	16.1	Direct.
9	0.62		0.46	0.30			
30	0.46	0.30	0.16	0.180	18.7	Reversed.
1	0.44	0.43	0.16			
2	0.44	} 0.27	0.43	0.16	0.180	18.7	Reversed.
3	0.30		0.15	0.35			
4	0.15	0.35	0.20	0.180	18.7	Reversed.
5	0.10	0.35	0.20			
6	0.10	} 0.00	0.35	0.20	0.180	18.7	Reversed.
7	0.00		0.35	0.20			

Mean of three direct = 15.8×10^{-7} cm.

Mean of three reversed = 18.0×10^{-7} cm.

TABLE III.

Readings to show the throw of the Diaphragm when a known current is applied. The first four columns are in units of the instrument, the fifth column is in terms of the unit 10^{-7} cm. The current in the sixth column is in terms of a special unit (1.43×10^{-6} amp.).

Normal Contact.	New Contact.	Difference.	Mean.	Corrected Mean, 10^{-7} cm.	Resistance and Current.
23.26	23.29	0.03	0.035	3.6	40,000 ω . C=25
23.45	23.48	0.03			
23.25	23.29	0.04			
23.30	23.34	0.04			
23.85	23.90	0.05	0.045	4.7	30,000 ω . C=33.3
23.76	23.80	0.04			
23.59	23.63	0.04			
23.56	23.61	0.05			
23.40	23.49	0.09	0.072	7.5	20,000 ω . C=50
23.34	23.42	0.08			
23.36	23.42	0.06			
23.70	23.76	0.06			
22.75	22.85	0.10	0.087	9.0	15,000 ω . C=66.6
23.20	23.29	0.09			
23.32	23.40	0.08			
23.31	23.39	0.08			
48.00	48.20	0.20	0.172	17.9	10,000 ω . C=100
47.85	48.00	0.15			
47.78	47.95	0.17			
47.55	47.72	0.17			
46.40	46.82	0.42	0.410	42.6	3,000 ω . C=320
46.25	46.65	0.40			
46.10	46.52	0.42			
45.90	46.52	0.40			
45.40	45.95	0.55	0.58	60.8	2,000 ω . C=470
45.40	46.00	0.60			
45.10	45.67	0.59			
44.97	45.57	0.60			
44.65	45.50	0.85	0.82	85.0	1,500 ω . C=625
44.50	45.30	0.80			
44.05	44.85	0.80			
44.50	45.32	0.82			
42.40	43.40	1.00	1.05	109.0	1,000 ω . C=890
42.35	43.40	1.05			
42.10	43.25	1.10			
41.50	42.50	1.05			

Voltage = 1.435 constant.

(2) Calibration.

If we assumed that the screw and the divisions of the disk were accurate in all respects, we should still have to determine the joint leverage of the three levers in order to measure any movement; but by the following method of calibrating we can obtain a knowledge of the value of the units on the disk without making even these assumptions.

In fig. 3 is given diagrammatically the plan of the apparatus involved. Fix to the end of the short arm of L_3 a glass plate (a), and close to it a small lens (b) supported from the frame of the apparatus. The plate was a microscope glass slide chosen for its good surface; it was held fast by a screw and nut between the lever and a brass washer.

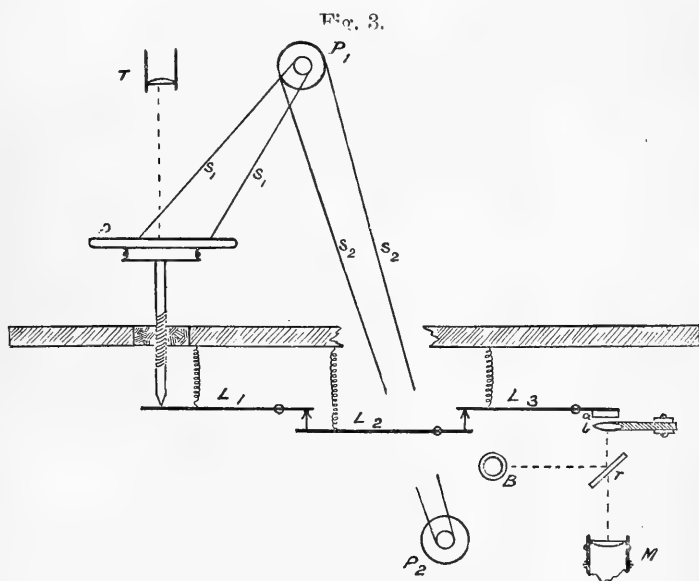

The lens was let into a saw-gate in a brass bar and fixed there by shellac; the brass bar was clamped by screws to a strong upright bar screwed to the wooden frame. Thus the glass plate is fixed to the lever, and the lens is fixed to the wooden frame, both are therefore shielded from the vibrations of the table.

Put up a Bunsen burner B , with sodium light and a glass plate r to reflect the rays normally to the glass surface, then an observer at the microscope M will, under favourable conditions, see at the glass surface the centre of a system of Newton's rings. The rings can be made to open out or con-

tract, according as the short arm of L_3 is moved towards or away from the observer. Suppose the rings are made to contract by the working of the pulleys, and that while the observer at M sees one ring absorbed, the observer at T sees the graduated disk move by n divs. Then the value of the disk units in terms of the wave-length of sodium light can be found.

The glass surfaces (a , b) must not touch during these observations. If the surfaces be moved uniformly together the ring system expands at a uniform rate until they touch, when the system begins to expand at a very much slower rate. Thus we shall know the position of contact.

The burner was surrounded by an Argand chimney, and glass plates (not shown in the figure) were placed between it and the rest of the apparatus to cut off heat. It was found well to leave the apparatus for 15 minutes after lighting up, till temperature equilibrium was established; then the rings were fairly steady, and observations could be obtained.

At first the plan was to have one observer at the telescope and another at the microscope, as above described. But this was unsatisfactory, there being a want of cooperation between hand and eye; so a second pulley string ($s_2 s_2$) was fitted to pulley P_1 and passed round pulley P_2 so that the microscope observer could move the ring system himself, and when the observer at the telescope called out a reading to him he put it down. This method of working was retained as satisfactory.

Table IV. shows the results ultimately obtained. The rings moved to some extent under the temperature changes (though this movement was small when precautions were taken). But we know about the time taken to pass from ring to ring, and by measuring the time taken for the creep of one ring, we can make a correction. This is the use of column 1.

It will be seen that the four means agree very well, but the individual values are not nearly so close; surprise may be felt at the considerable discrepancies, for if the apparatus in its general use were not more reliable than in this calibration it would not be very efficient. But the conditions in the two cases are very different, for in calibration (1) the levers are uncovered; (2) the burner being near causes considerable disturbances; (3) to avoid a large creep during an observation the levers are moved much faster than usual, which may cause shaking.

The value obtained from calibration agreed closely with the number previously estimated by measurement of the lever-arms.

The band system was disturbed by the passing of a cart

in the streets, the disturbance being visible before any sound of the cart could be heard.

In every such case a delay was required.

The value determined for one disk unit is given at the bottom of Table IV.

TABLE IV.

Calibration results for the apparatus, using the levers with the lowest (usual) ratio.

Numbers are expressed in a unit which is one hundred times the unit of the apparatus 10^{-7} cm..

Ring Creep.	No. of Rings.	Readings.	Diff.	Mean.	Ring Creep.	No. of Rings.	Readings.	Diff.	Mean.
1 ring in 60s contract.	5	6.1	11.7	13.9 or for 1 ring 2.78	1 ring in 30s contract.	10	23.1	27.2	27.7 or for 1 ring 2.77
		44.4	14.4				45.9	26.9	
		30.0	16.1				19.0	26.6	
		13.9	13.1				42.4	30.2	
		0.8	12.9				12.2	25.2	
		37.9	15.0				37.0	30.4	
		22.9	15.0				6.6	26.3	
		7.9	12.9				30.3	29.1	
		45.2	14.2				1.2	27.5	
		31.0					23.7		
1 ring in 40s contract.	5	26.8	15.1	13.74 or for 1 ring 2.75	1 ring in 30s contract.	10	44.2	27.4	27.5 or for 1 ring 2.75
		11.7	11.9				16.8	26.5	
		49.8	12.5				40.3	27.8	
		37.3	14.8				12.5	27.6	
		22.5	15.0				34.9	28.9	
		7.5	11.9				5.0	26.3	
		45.6	13.5				29.7	27.8	
		32.1	15.0				1.9	27.1	
		17.1	14.0				24.8	27.9	
		3.1					46.9		

Mean of 5 rings = 13.82.

Mean of 10 rings = 27.60.

Mean (of 270) for 1 ring = 2.76.

Or, allowing for creep = 2.84.

$$\therefore \frac{\lambda}{2} = 284 \text{ units.}$$

$$\therefore 1 \text{ unit} = \frac{589}{2 \times 284} \mu\mu = 1.037 \mu\mu.$$

Calibration work could not be done in the daytime; the working of a neighbouring factory caused a rhythmic fluctuation of the ring system.

Table V. gives a rough calibration for the lever system when the bearings were so placed that the leverage was higher. Only approximate values were obtained, for these leverages were never used in actual measurements; but it was interesting to find values for the higher leverages and to see how nearly they agreed with one another.

The highest leverage position gives for the value of one disk-unit the value $0.1 \mu\mu$, which is certainly small.

TABLE V.

Calibration results for the apparatus, using the levers in the middle and high ratios.

Ring Creep.	No. of Rings.	Readings.	Diff.	Ring Creep.	No. of Rings.	Readings.	Diff.
1 ring in 30 ^s contract.	1	36.2 9.8	26.4	None apparent.	5	23.5 40.0	33.5
	2	43.2 49.6	53.6		5	40.0 9.3	30.7
1 ring in 45 ^s contract.	2	49.9 17.3	52.6		5	9.3 27.1	32.2
	2	17.3 17.5	49.8		5	27.1 47.1	29.4
	2	17.5 14.6	52.9		5	47.7 13.6	34.1
					5	49.1 15.3	33.8
					5	15.3 32.5	32.8

1 ring (mean of 9) 26.2.

$$\therefore \frac{\lambda}{2} = 2620 \text{ units.}$$

$$1 \text{ unit} = \frac{588}{2 \times 2620} \mu\mu.$$

$$= 0.112 \mu\mu.$$

1 ring (mean of 35) 6.46.

$$\therefore \lambda = 646 \text{ units.}$$

$$1 \text{ unit} = \frac{589}{2 \times 646} \mu\mu.$$

$$= 0.45 \mu\mu.$$

(3) *Diaphragm Movement.*

There are two distinct measurements involved :—

A. Observe the position of the diaphragm at rest by making the contact *ab* (fig. 2, p. 543), then draw away *a*, and pass a steady current through the receiver so as to move the diaphragm to a new position of rest; now move up *a* slowly towards the diaphragm, watching the graduated disk and listening for contact. Thus we can measure the movement of the diaphragm centre due to a steady current. This we can do for any current down to such small ones as cause a movement too minute for observation; then we shall have a relation between current in the telephone, and diaphragm displacements, between any desired limits of the current. Plot a curve for this relation.

B. Unscrew the telephone holder from the apparatus, fit on an earpiece to it, and place the receiver in a circuit containing also a cell (whose E.M.F. is known), a resistance-box and a tapping-key, the receiver being shunted by another resistance-box.

If the ear is placed on the receiver when the key is released a sound is heard; this can be reduced in intensity by increasing resistance, or decreasing the shunt, until no sound is heard. Find the limit; this gives us the lower limit of audibility of sounds produced in this particular way as impulses. Observe the current used corresponding to the limit.

Now return to the curve obtained in A, and mark on it, by extrapolation, the current just found. This will give us the movement corresponding to the smallest audible sound impulse.

It must be observed that we are dealing with an impulse, for the diaphragm is released from a position of strain, vibrates for some time under considerable damping, and so soon comes to rest. In Section IV. an attempt is made to represent roughly the nature of the impulse in this special case.

The diaphragm in its vibration has its own particular frequency, and our determination refers to this frequency.

In all cases I measured my own limit of hearing (for both ears) so that the value obtained is probably somewhat low, as I have had considerable practice in listening to small telephone sounds.

So faint is the smallest sound that the observations were only possible in the dead of night.

Tables VI A., VII A., VIII A. give four complete sets of diaphragm readings.

Tables VI B., VII B., VIII B. give the corresponding currents for smallest sound-impulses (p. 554).

TABLE VI A.

Showing Diaphragm movements for given steady currents.
The same units for length and current as used previously.

Movement.	Mean.	Corr. Mean, $\mu\mu$.	Resistance and Current.	Movement.	Mean.	Corr. Mean, $\mu\mu$.	Resistance and Current.
0.02 0.02 0.03	0.027	2.8	75,000 ω . C=13.2	0.13 0.13 0.12	0.127	13.2	20,000 ω . C=50
0.03 0.03 0.03	0.03	3.1	60,000 ω . C=16.6	0.15 0.16 0.17	0.16	16.6	15,000 ω . C=66.6
0.03 0.04 0.03	0.033	3.4	50,000 ω . C=20.	0.20 0.25 0.22	0.22	22.9	10,000 ω . C=100
0.04 0.03 0.04	0.037	3.9	45,000 ω . C=22.2	0.40 0.38 0.38	0.387	40.3	5,000 ω . C=195
0.05 0.04 0.04	0.043	4.5	40,000 ω . C=25	0.55 0.50 0.60	0.55	57.2	3,000 ω . C=320
0.05 0.06 0.05	0.053	5.5	35,000 ω . C=28.6	1.30 1.25 1.20	1.28	133.0	1,000 ω . C=893
0.08 0.08 0.07	0.077	8.0	30,000 ω . C=33	2.00 1.90 1.90	1.93	201.0	500 ω . C=1660
0.10 0.10 0.10	0.100	10.4	25,000 ω . C=40	3.50 3.50 3.60	3.50	367.0	200 ω . C=3100

E.M.F.=1.430 V. constant.

TABLE VI B.

Readings of Steady Current corresponding to smallest audible impulse.

Main Resistance.	Shunt-Resistance.		Current.	Mean.
	Left Ear.	Right Ear.		
100,000 ω .	40 ω .	40 ω .	2.53	2.60
75,000 ω .	20 ω .	40 ω .	2.66	

TABLE VIIA.
Similar to Table VIA.

Movement.	Mean.	Corr. Mean, $\mu\mu$.	Resistance and Current.	Movement.	Mean.	Corr. Mean, $\mu\mu$.	Resistance and Current.
0.01 0.02 0.03	0.02	2.1	75,000 ω . C=13.2	0.10 0.10 0.11	0.103	10.7	20,000 ω . C=50
0.03 0.02 0.03	0.027	2.8	65,000 ω . C=15.4	0.12 0.13 0.12	0.123	12.8	15,000 ω . C=66.6
0.03 0.04 0.04	0.037	3.9	50,000 ω . C=20	0.18 0.20 0.20	0.193	20.1	10,000 ω . C=100
0.05 0.04 0.05	0.043	4.5	45,000 ω . C=22.2	0.28 0.30 0.28	0.287	29.9	5,000 ω . C=195
0.06 0.05 0.05	0.057	5.9	40,000 ω . C=25	0.40 0.40 0.38	0.393	40.9	3,000 ω . C=320
0.06 0.07 0.06	0.063	6.5	35,000 ω . C=28.6	1.20 1.10 1.20	1.17	122.0	1,000 ω . C=893
0.07 0.08 0.07	0.073	7.6	30,000 ω . C=33.3	2.20 2.22 2.20	2.21	230.0	500 ω . C=1860
0.08 0.09 0.08	0.077	8.0	25,000 ω . C=40	3.10 3.15 3.10	3.12	324.0	300 ω . C=2380

E.M.F.=1.430 V. constant.

TABLE VII B.
Similar to Table VI B.

Main Resistance.	Shunt-Resistance.		Current.
	Left Ear.	Right Ear.	
100,000 ω	40 ω	40 ω	2.53

TABLE VIII A.
Similar to Table VI A.

Move- 11.	Mean.	Corrected Mean, $\mu\mu$.	Resistance and Current.	Movement.	Mean.	Corrected Mean, $\mu\mu$.	Resistance and Current.
0.02 0.03 0.02	0.023	2.4	75,000 ω . C=13.2	0.09 0.10 0.10	0.097	10.1	25,000 ω . C=40
0.03 0.03 0.03	0.030	3.1	65,000 ω . C=15.4	0.12 0.13 0.12	0.123	12.8	20,000 ω . C=50
0.03 0.04 0.03	0.033	3.4	55,000 ω . C=18.2	0.20 0.20 0.20	0.200	20.8	10,000 ω . C=100
0.03 0.04 0.04	0.037	3.9	50,000 ω . C=20	0.30 0.32 0.28	0.300	31.2	5,000 ω . C=195
0.05 0.05 0.04	0.047	4.9	45,000 ω . C=22.2	0.50 0.50 0.47	0.49	51.0	3,000 ω . C=320
0.05 0.06 0.06	0.057	5.9	40,000 ω . C=25	1.30 1.35 1.40	1.35	140.0	1,000 ω . C=893
0.07 0.06 0.08	0.070	7.3	35,000 ω . C=28.6	3.10 3.10 3.20	3.13	325.0	300 ω . C=2380
0.08 0.09 0.08	0.087	9.0	30,000 ω . C=33.3				

E.M.F.=1.430 V. constant.

TABLE VIII B.

Main Resistance.	Shunt Resistance.		Current.
	Left Ear.	Right Ear.	
100,000 ω .	40 ω .	40 ω .	2.53

The curves on fig. 4 are taken from VI A., VII A., VIII A.

In these curves the points are not very uniformly distributed along the lines drawn; but this is natural, for the readings were taken for such small distances (3×10^{-7} centim. or so) that the apparatus in its present form was near the limit of its working power.

Fig. 4.

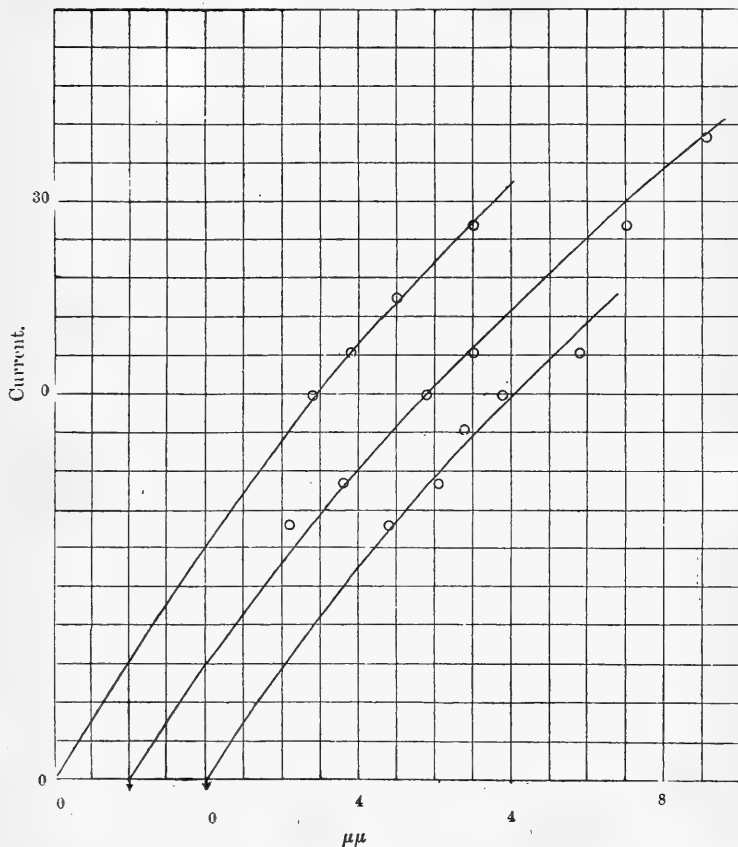

Extrapolation was used to arrive at the results; but it was not very hazardous extrapolation, since the curve is merely continued to the origin, through which it obviously passes. The values obtained from the curves agree very closely, the average being $0.37 \mu\mu$ for the smallest audible impulse.

If this is taken as a true value, the amplitude for the continuous uniform vibration audible cannot be greater than

0.37 $\mu\mu$ and is probably less. Our value would seem to be a superior limit.

The Tables VI A., VII A., VIII A. furnish not only the curves on fig. 4 for small displacements (0-10 $\mu\mu$), but also those on fig. 5 for medium displacements (10-160 $\mu\mu$). Here the readings can be taken with greater percentage accuracy, and the points lie more uniformly along them.

Fig. 5.

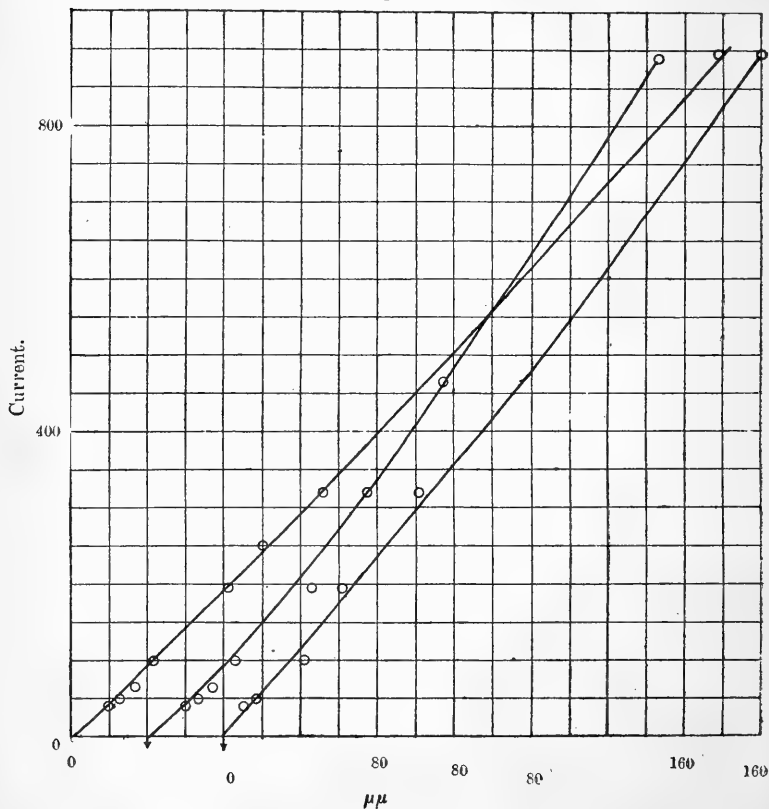

That the curves are not parallel to one another and even cross, as in fig. 5, is not surprising, for the receiver is set up differently for each curve obtained, so that a small difference in the tightening of the diaphragm would make a difference in the ratio current/displacement, and so the general direction of the curve would be different.

In fig. 4 the curves will be seen to be concave to the line of abscissæ. Now it is obvious that for large currents the

curve will be convex in the above sense, and we might reasonably expect it to be so throughout the curves to the origin. But if the curve when very near the origin has a point of flexure as supposed, we see the importance of plotting the curve in this region so as to obtain its true shape.

This peculiarity might arise from (1) a "buckle" in the diaphragm; (2) irregularities in the field. But we have no data for deciding between these various speculations.

TABLE IX A.

Similar to Tables VI., VII., VIII., but having larger diaphragm displacements.

Movement.	Mean.	Corr. Mean, $\mu\mu$.	Throw.	Current and Resistance.	Movement.	Mean.	Corr. Mean, $\mu\mu$.	Throw.	Current and Resistance.
0.70					12.0				
0.70	0.72	75.0	1.30	2000 ω .	12.05	12.0	1250.0	13.0	20 ω .
0.75				C=472	11.95				C=7140
1.30					13.5				
1.30	1.297	134.0	2.0	1000 ω .	13.4	13.47	1397.0	10 ω .
1.29				C=893	13.5				C=7690
2.50					51.2				
2.60	2.53	263.0	3.40	500 ω .	52.0	51.2	5320.0	55.2	10 ω .
2.50				C=1610	50.5				C=30,760
5.3					52.8				
5.4	5.33	554.0	6.8	200 ω .	52.0	52.6	5470.0	56.9	5 ω .
5.3				C=3125	53.0				C=32,000
7.5					54.0				
7.5	7.37	767.0	8.3	100 ω .	54.5	54.3	5650.0	57.5	2 ω .
7.7				C=4540	54.5				C=32,800
9.8									
9.9	9.83	1020.0	10.5	50 ω .					
9.8				C=5880					

E.M.F. { First six sets 1.430 V. constant.
 Last three sets 5.900 V. constant.

TABLE IX B.

Kind of Impulse.	Volts.	Main Resistance.	Cell Resistance.	Current.
Begins to be comfortably loud	1.43	10,000 ω .	2 ω .	100
" " uncomfortably loud ...	1.43	100 ω .	2 ω .	4,500
" " unbearable.....	6.0	5 ω .	8 ω .	30,800

TABLE X A.
Similar to Table IX.

Movement.	Mean.	Corrected Mean, $\mu\mu$.	Throw.	Corrected Throw, $\mu\mu$.	Current and Resistance.
0.90 0.93 0.95	0.93	97.0	1.25	130.0	10,000 ω . C=400
1.25 1.25 1.30	1.27	132.0	2.00	208.0	5,000 ω . C=780
3.50 3.55 3.45	3.50	364.0	4.7	489.0	2,000 ω . C=1890
6.25 6.20 6.30	6.25	650.0	9.0	936.0	1,000 ω . C=3570
11.9 11.8 11.7	11.8	1230.0	18.7	1940.0	500 ω . C=6440
31.0 31.3 31.3	31.2	3245.0			100 ω . C=18,200
40.0 40.5 39.7	40.0	4160.0			50 ω . C=23,500
51.8 52.4 52.5	52.0	5460.0			5 ω . C=32,000

E.M.F.=5.90 V. constant.

TABLE X B.

Kind of Impulse.	Volts.	Main Resistance.	Cell Resistance.	Current.
Begins to be comfortably loud	5.90	10,000 ω .	8 ω .	410
" " uncomfortably loud...	5.90	400 ω .	8 ω .	7,700
" " unbearable	5.90	5 ω .	8 ω .	30,300

From the data obtained an attempt was made to draw up roughly a scale of loudness, thus:—

(1)	Begins to be audible	0.4 $\mu\mu$
(2)	„ „ comfortably loud	50 „
(3)	„ „ uncomfortably loud	1000 „
(4)	„ „ overpowering	5000 „

We need standards of loudness corresponding to our system of standards of light-intensity. (2), (3), and (4) are only meant to be rough indications, but (1) (which is a direct test of the limit of hearing and does not involve the observer's personal judgment of loudness) is much more important. The values for it agree well together*.

(4) *The Damping of the Diaphragm.*

In Section III. a measurement is made of sound-impulses. It is interesting, therefore, to know the nature of these impulses, *i. e.* the extent to which the vibrations are damped.

We proceed thus:—(1) Measure the position (a) of the contact of the telephone when no current is passing in it. (2) Pass a current in the telephone so as to draw the diaphragm away from contact, then measure the new contact-position (a_0). (3) Draw away the contacts, and then stop the current; the diaphragm will be released and will just make contact if we arrange the pointer aright; measure this contact-position (a_1).

It is to be understood that a_0 and a_1 and a_n are displacements from the normal position a ; then $\frac{a_1}{a_0} = \rho$, is the damping factor for one $\frac{1}{2}$ vibration.

For a few vibrations it seems fair to assume for our purposes that ρ does not alter much.

Then we have for the position after n half-vibrations,

$$\left(\frac{a_1}{a_0}\right)^n \cdot a_0 = a_n.$$

* A. Franke (see Proc. Soc. Tel. Eng. vol. xvi.) made a determination of the amplitude of a diaphragm for the smallest sound audible. The value obtained was 1.2 $\mu\mu$. But whereas it refers to a continuous sound, the value obtained by the author refers to a sound-impulse. The method of Franke was an interference optical one, and the smallest measured displacement was 52 $\mu\mu$; also he seems to have trusted to having a straight line from that point to the origin.

Cross & Mansfield (Proc. Amer. Acad. vol. xx. 1893) summarize the work which had been done on this value.

On this basis plot a curve for the impulse (fig. 6).

Fig. 6.

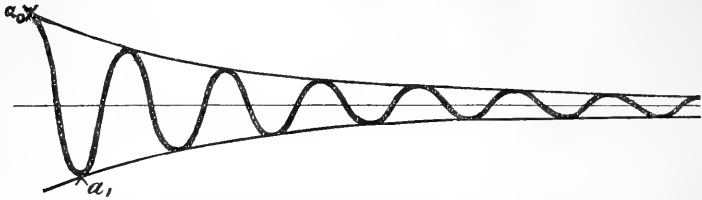

From ten observations on small distances the mean value for ρ was approximately $\frac{5}{6}$.

Besides the work above indicated, many other measurements were made, viz. (1) microphone action of various substances; (2) the movement of the receiver-diaphragm when in circuit with a transmitter in action; (3) apparent coherence of the surfaces under certain conditions.

These applications will be reserved at present.

SUMMARY.

The main purpose of this paper is to show:—

- (1) That this method of measuring small distances by electric contact is reliable.
- (2) That, whereas in other methods for measuring small distances a limit to working is made by the size of some wave-length, in this method the limit is far lower, is not thus dependent, and has not been reached in the apparatus so far made.
- (3) That a measurement can be made of the smallest audible impulsive sound given by a telephone-diaphragm.
- (4) That the method will probably have many other applications, where small measurements are involved.

The author wishes to thank Mr. W. H. Everett, B.A., B.E., for some valuable suggestions, and Professor W. H. Heaton, M.A., for his kind interest in this research.

LIV. *On the Potential Gradient in the so-called Faraday Dark Space of Vacuum-Tubes as Related to Conditions Prevalent at the Cathode.* By CLARENCE A. SKINNER, Ph.D., Adjunct-Professor of Physics in the University of Nebraska*.

IN a former paper † results were given showing that, on sending a current of electricity through nitrogen at about one millimetre pressure, the space of strikingly low potential gradient near the anode increases in extent as the drop of potential at the anode augments. This was attributed to a disturbance sent out from the anode. At the same time it was suggested that the low gradient of the Faraday dark space was likewise due to the "drop" at the cathode.

The present paper contains primarily the results of a series of experiments, made for the purpose of studying the relation existing between the potential gradient of this dark space and the conditions at the cathode. The results, as will be seen, trace the lower gradient (compared with that in the luminous column) to cathode radiation.

Measurements of the gradient in the Faraday dark space were first made by Hittorf ‡, and recently more exhaustive measurements have been made by Graham §. The latter studied it in nitrogen at a definite distance from the cathode, by measuring the difference of potential between two parallel wires inserted respectively in two successive cross-sections of the discharge-tube. His results gave the variation (at the position noted) of the gradient with the current, at various gas-pressures—the whole, however, connected with a considerable cathode "drop." Graham also obtained by means of moveable wires the general form of the gradient throughout the dark space—not, however, in its relation to the cathode, with which this paper deals.

Apparatus.

The method used was the second adopted by Graham. Fig. 1 shows the discharge-tube sealed to an open top barometer-tube *b*, through the mercury column of which rises one arm of a U-tube carrying the exploring-wires, while the other arm passes to the outside through the reservoir below (not shown). By this means the exploring-wires are

* Communicated by the Author.

† C. A. Skinner, *Wied. Ann.* lxviii. p. 752 (1899).

‡ W. Hittorf, *Wied. Ann.* xx. p. 705 (1883).

§ W. P. Graham, *Wied. Ann.* lxiv. p. 49 (1898).

placed at any desired position along the axis of the discharge-tube, the same being noted on a scale attached to the barometer-tube. The connexion between the exploring-wires and the electrometer passes, air-tight, through the U-tube. The discharge-tube is jointed in the middle, thus allowing the exploring-wires to be adjusted, and the electrodes to be exchanged. Its diameter is about 40 mm., and the distance between the electrodes 145 mm.

Observations were made in nitrogen only. This was prepared from air and purified after the method of Hittorf*, freed from the last trace of oxygen by nascent sodium †, and thoroughly dried in a chamber containing phosphorus pentoxide. Special effort was made to remove all trace of moisture, which seems to be the cause of much uncertainty in vacuum-tube discharge. For this purpose a tube of phosphorus pentoxide was placed between the Rapps automatic air-pump and the rest of the system of apparatus, and another of calcium chloride between the pump and the aspirator. In addition, only *dry* air was allowed in contact with the mercury used in pumping. Leakage was guarded against by securing all ground joints with mercury (excepting the discharge-tube, the joint of which proved absolutely air-tight). It is believed that these precautions insured a degree of constancy, with a rate of operation, which in vacuum

discharge is exceptional. The electric current was produced by a battery of 600 secondary cells, and measured by a Weston milliammeter (scale-divisions in tenths). All potential measurements were made by a Thomson quadrant electrometer carefully insulated, while sealing-wax insulators and

Fig. 1.

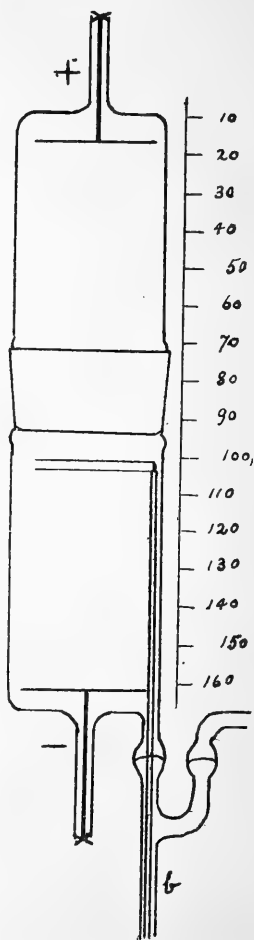
* *Loc. cit.* p. 725.† See E. Warburg, *Wied. Ann.* xl. p. 1 (1890).

paraffin switch-blocks were used throughout. Potentials of the magnitude of the cathode "drop" were made by charging the quadrants with a Clark standard cell and the needle with the potential to be measured. A Hittorf cadmium-iodide resistance* was used to regulate the current, the continuity being tested by the receiver of a telephone.

Preliminary Tests.

To provide an experimental check on results, two vacuum-tubes were fitted out, alike in all respects, and in open connexion with each other. Observations made in one could thereby be repeated immediately afterwards in the other.

Platinum exploring-wires (diam. two-tenths mm.; distance apart 3.5 mm.) were first used, but the gradients obtained from the two tubes seldom agreed. Furthermore, when the current was reversed, the constant gradient of the luminous column appeared often greatly increased (or diminished). A discharge sent from the exploring-wires as cathode tended to reduce these discrepancies, thus proving that they arose from the condition of the surface of the wires.

Aluminium wires (of same diameter and distance apart as the platinum) were tried, gave very constant results, and were subsequently used, making check-observations in the second tube in general unnecessary. The gradient indicated by these was *regularly* about 35 per cent. above that calculated from the difference of potential observed between the extremities of the luminous column. This discrepancy is probably due to a local disturbance of the discharge caused by the presence of the wires.

Circular disks of polished iron were used as electrodes. To allow for a considerable variation in the current strength with the cathode "drop" constant, it was found necessary to give these a diameter of 30 mm.

Faraday Dark Space.

In Tables I., II., and III., the values of the gradient for various currents and different gas-pressures are given. These all refer to a constant drop at the cathode of about 320 volts. The observed gradient is reduced to volts per centimetre, and the positions are as indicated in fig. 1. Though these tables are chosen as the best from several series of observations, at various gas-pressures, yet results obtained at different times under the same conditions varied never more than ten per cent., and usually no more than five.

* W. Hittorf, *Wied. Ann.* vii. p. 559 (1879).

TABLE I.—Potential Gradient in Volts per Centimetre for Various Currents. Gas-pressure .6 mm.
Position of Anode 17. Position of Cathode 162.

Position in mm.	.5 m.a.	1 m.a.	2 m.a.	4 m.a.	6 m.a.
19	23.5	25.5	24.5	27.5	18.5
21	27.5	28.0	31.0	30.0	
25	27.0	27.5	29.0	27.0	10.0
30	27.5	
35	26.5	
40	27.0	27.0	29.0	13.0
50	24.0	
60	28.5	30.0	29.0	12.0
62	26.5	
70	30.5	21.0	
80	29.0	29.5	24.0	14.5	7.5
90	23.0	17.0	15.5	11.5	
100	13.0	10.5	9.5	6.5	4.5
110	9.0	4.5			
120	2.0	2.0	1.0	0
130	2.0	.5			
140	3.55		
150	13.0				

TABLE II.—Potential Gradient in Volts per Centimetre for Various Currents. Gas-pressure 1.0 mm.
Position of Anode 17. Position of Cathode 162.

Position in mm.	.35 m.a.	.4 m.a.	.5 m.a.	.7 m.a.	1.5 } 3.0 } m.a.	6.0 m.a.
19	34.5	18.5	18.5	36.5	41.5	43.5
25	39.5	42.0	42.5	43.0	38.5
40	38.5	39.0	39.5	39.5	40.5	31.0
60	41.0	42.0	41.0	42.0	42.0	27.5
80	42.0	43.0	42.0	42.5	35.0	22.0
100	39.0	40.0	40.5	31.5	20.0	11.0
120	40.5	38.5	34.5	14.5	6.0	6.5
135	42.0				
140	42.5					
150	21.0	1.0

TABLE III.—Potential Gradient in Volts per Centimetre for Various Currents. Gas-pressure 1.5 mm. Position of Anode 17. Position of Cathode 162.

Position in mm.	.5 m.a.	.8 m.a.	1.0 m.a.	1.5 m.a.	6.0 m.a.
19	60.5
25	53.5	55.0	55.0	55.0	35.0
40	51.5	53.0	54.0	54.5	31.0
60	55.0	55.0	56.0	29.5
80	54.0	56.0	57.0	51.5	22.0
100	49.5	55.0	47.5	29.5	16.5
120	53.0	44.0	25.5	13.0	9.0
140	58.5	27.5	10.0	2.5	2.0
150	22.0	1.0
154	11.0

These values of the gradient are represented graphically in fig. 2 (for .6 mm.), 3 (for 1 mm.), and 4 (for 1.5 mm.). It

Fig. 2.

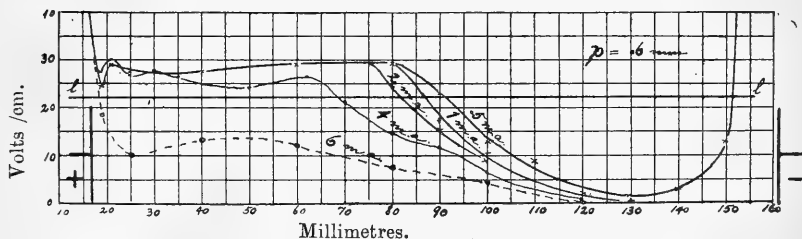
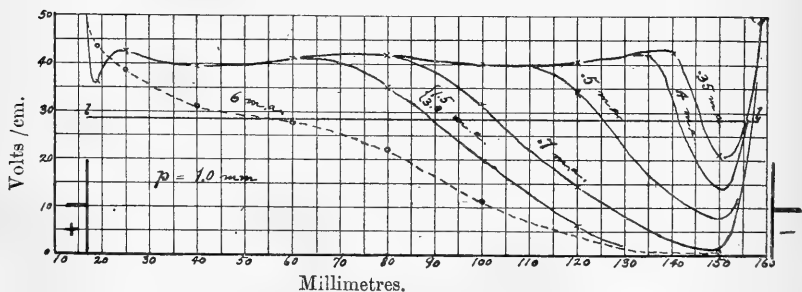

Fig. 3.



was observed that the negative extremity of the luminous column could be indicated in the figures by the intersection of the corresponding gradient with the horizontal line 11.

While this gives the positive boundary of the Faraday dark space (within an error of observation of possibly 5 mm.), it was also noted that the negative boundary of this space could be located as at the second intersection of 11 with the gradient, as it rises rapidly near the cathode. (The negative glow in these experiments was of small extension.)

Fig. 4.

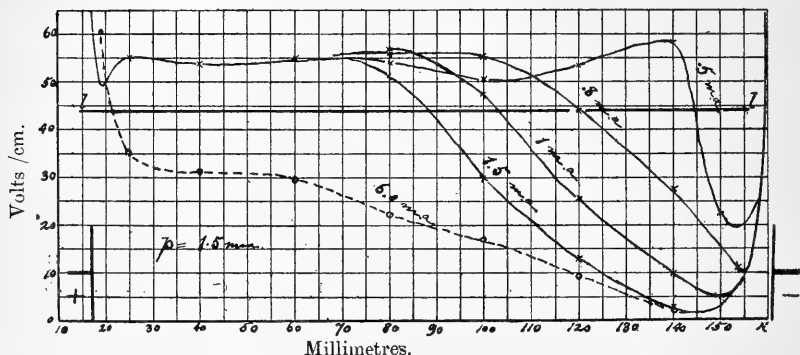

The full-line curves represent the results obtained with a luminous discharge, while the dotted curves refer to the dark discharge, produced by increasing the current to a value such that the luminous column was driven back into the form of a disk on the face of the anode.

Considering first the gradient for the luminous discharge, it may be observed that, *with increasing current the Faraday dark space increases in extent, driving the luminous column before it; this is accompanied by a decrease in the gradient throughout the dark space.* To this conclusion the results show a single exception, seen in fig. 3, in which the curves for 1.5 and for 3 milliamperes coincide. This exception, which led to an explanation of the cause of the dark space, is considered in another paragraph.

It is also seen that *the less the extent of the dark space from the cathode, the greater the rate of increase in extent with the current.*

Again, *with increasing gas-pressure, the dark space for the same current decreases in extent.*

As found by Graham (*loc. cit.*) and corroborated lately in the results of H. A. Wilson*, the gradient drops to a very low minimum immediately before its rapid rise near the cathode. These curves show, however, that although with the larger currents this minimum approaches a zero value, yet with

* H. A. Wilson, *Phil. Mag.* xlix. p. 505 (June 1900).

a very small current and higher gas-pressures it may reach a considerable value. Graham's curves show on the whole two minima in this space separated by a small maximum. Those of Wilson show this maximum exceptionally marked. With a cathode 2 centim. in diameter, I observed likewise a small maximum between two minima, but with the larger cathode (diam. 3 cm.) the maximum was at no time detectable, thus indicating it as probably dependent on the density of the discharge from the cathode-surface.

As to the range over which the observations extended, it may be stated that they were made for gas-pressures intermediate between, as lower limit, the pressure at which the luminous column is still unstriated (about .6 mm.), and as upper limit (2 mm.), the power-limit of the battery. The current ranged from the lowest possible to that which produced the dark discharge. The difficulty attached to the maintenance of small constant currents lies probably in the unstable condition of the conducting gas, as seen in the variation in the total drop of potential between the electrodes with the current. The total drop of potential throughout the conducting gas, being proportional to the area contained between the gradient and the axes of coordinates, is seen with small currents especially to decrease rapidly with increasing current; and the reverse, increases rapidly with decreasing current. Thus the action of the gas is to magnify any variation in the rest of the circuit, and to lend itself, with a capacity and high resistance in the circuit, readily to a pulsating discharge. Another difficulty in maintaining constant small currents arises when the discharge, taking place from smaller and smaller surfaces of the cathode as the gas-pressure increases, being reduced to a spot on the cathode, dances rapidly about over its surface.

Returning to the fact that the curve in fig. 3 for 3 m.a. coincided throughout with that for 1.5 m.a., it was noticed at the same time that, with the current very slightly above 1.5 m.a., the discharge began to take place from the back surface of the cathode also. This suggested that the dark space was under the direct influence of a radiation from the discharging-surface of the cathode. To test this point the cathode was turned, as shown in fig. 5, with its plane lying in the axis of the discharge-tube, so that any disturbance sent out normal to its surface would be directed against the walls of the tube. In addition, any component radiation along the axis of the tube was prevented by a glass cylinder which surrounded the cathode co-axially.

Under these conditions the luminosity, with an unstriated

discharge, appeared as outlined by the dotted lines in the figure. The luminous column extended up near the open end of the cylinder and held there tenaciously for all currents up to 5 and 6 m.a., not retreating as much as a centimetre at any time. A permanent horse-shoe magnet held so that cathode rays would be deflected upwards caused the luminosity to retreat slightly, while the reverse position caused it to extend. The potential gradient in the luminous column rose slightly in passing from anode to cathode, more rapidly in the constricted portion than in the other. With the striated discharge, while the luminosity did not extend up to the cylinder-screen, but to about 3 cm. above it, it required a current considerably larger than under ordinary circumstances to cause it to retreat perceptibly towards the anode. The striations were in this case of keener outline and more intense luminosity on their negative face. With both striated and unstriated discharge, by simply reversing the current, so that the cathode was above, the luminous column was quickly driven behind the cylinder screen, the change being accompanied by a considerable increase in the current. These results indicate that the Faraday dark space is under the influence of a radiation emanating directly from the discharge-surface of the cathode, rather than from a secondary disturbance produced by the discharge in the neighbouring gas.

The results embodied in the curves already considered, appear entirely in agreement with the conclusion that the Faraday dark space is swept by cathode rays, which are conceived as the negative ions driven forth with a velocity acquired through the excessive "drop" at the cathode, and giving up their kinetic energy in ionizing the gas through which they drive. All the curves (that for .8 m.a., fig. 4, possibly excepted) show, in their convexity to the axis of abscissas throughout the dark space, that, according to Prof. J. J. Thomson*, ionization is in excess there. There is a considerable region, however, lying next the luminous

Fig. 5.

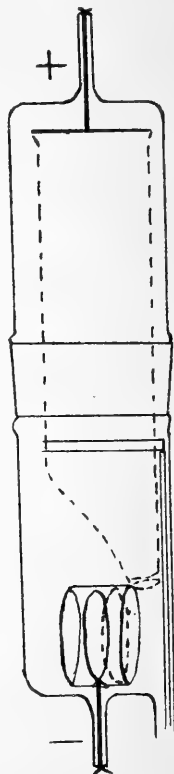

* Prof. J. J. Thomson, *Phil. Mag.* xlvii. p. 252 (1899).

column, where this convexity is very slight, yet from the fact that it disappears when the cathode rays are turned aside, it must be considered as under the control of cathode radiation.

In connexion with these considerations, the curves of H. A. Wilson (*loc. cit.*) showing the electric conductivity of the gas normal to the direction of the current are of special interest. According to these the conductivity of the Faraday dark space increases in passing towards the cathode, which agrees with the decreasing gradient, and with an increasing ionization as the source of the cathode rays is approached. Passing in the opposite direction through the dark space into the luminous column, while the *gradient shows* that the *conductivity decreases gradually* to a constant *minimum* in the *luminous column*, a certain *region* in the *dark space* is reached where, on the other hand, the *conductivity* in a direction *normal* to the current becomes a *minimum*, then *rises* to a constant value in the *luminous column*. Were the conductivity dependent on the degree of ionization alone, it should be independent of the direction in which it is measured. Some other factor evidently enters to which this difference must be ascribed.

While Wilson suggests it to be due to the luminosity ionizing the gas at the surface of the "cross-current" electrodes, and thus, for the same difference of potential between them, allowing a larger "cross-current" to pass in the luminous portions than in the dark spaces; it may also be explained from the conclusion that cathode rays are active in producing the dark space. This explanation rests upon the assumption that the negative ions driving through the gas with a decreasing velocity, cease to ionize it while their velocity is still above that maintained by them in the luminous column. Since the conductivity in any direction (other conditions remaining the same) must increase with increased velocity of the ions in that direction, the conductivity along the discharge, in the higher velocity non-ionizing region of the negative ions, would be greater than in the luminous column, and also greater than in a direction at right angles to the discharge in the same region. Furthermore, with the same degree of ionization in the luminous column as in this region, the conductivity at right angles to the direction of motion of the ions would be lower in the latter, due to the stream tending to carry them past the limited "cross-field." It seems possible that, with a sufficient velocity of the ions along the direction of the discharge, the conductivity at right angles might be reduced without limit.

Gradient near the Anode.

We have in the above results an explanation of the low gradient near the anode also. The positive ions driven forth with a velocity imparted by the anode "drop" render the space in which the higher velocity is maintained more conductive thereby in the direction of their motion. That these do not ionize the gas through which they drive, but on the other hand increase the conductivity at right angles, may be seen in the fact that (as given by Wilson) the curve of conductivity drops to a very small value in this space.

The potential gradient near the anode in figs. 2, 3, and 4 reaches a minimum, though not a zero value as found earlier and also corroborated by Wilson. The drop of potential at the anode was normal (18 to 25 volts), so that this discrepancy is probably to be attributed to the large discharge-surface of the anode used in this investigation.

Another observation made in connexion with the anode is of interest, in that it concerns a questionable state of the gas near the anode. As has been noted in the earlier communication by me, and more thoroughly studied by Wilson, with striated discharge the gradient in the striation on the anode is apparently negative. With the larger anode used in this investigation the same has been observed in an unstriated discharge, though not always. In one case the minimum potential-difference between the anode and the first exploring-wire was obtained with the wire at a distance of one centimetre from the anode. This increased perceptibly as the wire approached the anode, while at the same time a shadow of the wire was cast on the face of the anode. A *negative* gradient was thus indicated, yet the gradient indicated by the exploring-wires was a considerable *positive* quantity. The discrepancy in this case must be attributed to a disturbance of the discharge at the anode by the proximity of the exploring-wires. This strengthens then the view that former similar results were due to the same cause, rather than that there is actually a negative electric intensity in the space considered.

Striations.

In fig. 2 the curve for 4 m.a. represents the gradient for a clearly-marked striated discharge produced by simply increasing the current above 2 m.a. It was repeatedly observed that with the pressure of the gas near the limit between the striated and unstriated discharge, the latter could be converted into the former by increasing the current—likewise the reverse. This change is gradual. With a pressure of

about .4 mm. the current at which the transformation took place was smaller than in this case, while at lower pressures only the striated condition was observable. These observations are of possible interest in connexion with the theory of J. H. Jeans*, who deduces the curve for a striated discharge from the conditional equations of Prof. J. J. Thomson (*loc. cit.*) under the assumption that the density of the ions shall remain finite.

The explanation, given above, of the difference in conductivity along, and at right angles to, the direction of the discharge may be briefly applied to the striated discharge. Wilson found the curve of conductivity at right angles to possess maximum values in the luminous parts and minimum in the dark spaces, which is exactly opposite to the curve of conductivity along the discharge (as given by the potential gradient), where the dark spaces possess maximum conductivity. Thus we find maximum and minimum for one direction, coinciding respectively with minimum and maximum taken at right angles thereto.

We may assume that the ions possess a zero velocity at right angles to the direction of the discharge. Then, supposing the degree of ionization constant, the regions of maximum velocity along the discharge will be, due to this velocity, regions of maximum conductivity along, and of minimum conductivity at right angles.

If we suppose the velocity of the ions constant throughout, then regions of maximum conductivity in both directions will coincide with regions of maximum ionization, and with each other. The latter condition is impossible because contrary to experimental results. If we suppose maximum ionization in the luminous and minimum in the dark spaces, the velocity in the latter must be sufficient to compensate for the minimum ionization there, so that the conductivity along the discharge may be greater in the dark spaces, as the gradient requires.

If, lastly, we suppose, according to Prof. Thomson, maximum ionization in the dark spaces, the velocity there must be sufficient to produce minimum conductivity at right angles.

All three possible cases require a greater velocity of the ions in the dark spaces than in the luminous. This is of interest in connexion with the theory of Spottiswoode and Moulton †, that the current is transmitted by successive discharges across the dark spaces, from which a greater velocity of the ions in these spaces would logically follow.

* J. H. Jeans, *Phil. Mag.* xlix. p. 245 (March 1900).

† Spottiswoode & Moulton, *Phil. Trans.* 1879, part 1, p. 201.

Dark Discharge.

The gradient as given in the full-line curves in figs. 2, 3, and 4 is single-valued for a cyclic variation of the current, so long as its strength is kept below a certain value. If it rises above that value, the luminous column, under constant current, gradually retreats into a thick disk on the anode, giving the so-called dark discharge. The dotted curves in figs 2 and 4 (for 6 m.a.) represent the gradient after this change had been brought about; the one in fig. 3 represents it during the transition, in which the luminous column extends (as in the full-line curves) from the anode to the intersection of the gradient with the line 11. After the dark discharge has set in, the gas requires a certain period to recover the power of transmitting a current by the luminous discharge. In one case the gas was observed to recover its natural luminosity and normal gradient within half an hour after the current was broken; but in general, the longer the period of dark discharge, the longer the period required for recovery. Two to three hours was always sufficient to recover both luminosity and gradient.

With the cathode screened as in fig. 5, the dark discharge could not be produced by double the current (10 to 12 m.a.) usually necessary when the cathode was discharging along the axis of the tube. This, in connexion with the fact that the dark discharge is ushered in, as it were, by a growth of the Faraday dark space, indicates that the transition from the luminous to the dark discharge is at any rate largely facilitated by cathode radiation.

Luminosity.

As already stated, the line 11 marks by its intersection with the potential gradient the limit of the unstriated luminous column. It may be observed in the curves given, that where the gradient falls twenty-five per cent. (roughly estimated) below its constant value in the luminous column, that region is dark. It was also noticed in this connexion, that as the gas recovered from the dark discharge, the luminosity increased, as the gradient having risen above 11, approached its normal value.

Physical Laboratory,
University of Nebraska, Lincoln,
Aug. 8, 1900.

LV. *Note on a Possible Source of Error in the Use of a Ballistic Galvanometer.* By R. BEATTIE, B.Sc.*

UNLESS more than ordinary care is taken in setting up a ballistic galvanometer of the movable magnet type, the chances are that the magnetic axis of the needle does not lie exactly in the plane of the coil. Whenever this is the case, the magnetic field set up in the galvanometer during the passage through it of a quantity of electricity has a component along the needle's length tending to alter temporarily its magnetic moment, and so tending to modify the throw—causing it to be in defect of a normal throw when the needle in its first swing passes through the plane of the coil, in excess when it does not. If we admit that the change, supposed small, in the magnetism of the needle is at each instant proportional to the component of the field in the direction of the needle's axis, we can readily find an expression for the amount of the error which is thus introduced. For it is then not difficult to show that the throw is proportional, not to the quantity Q of electricity which traverses the galvanometer, but to

$$Q + \alpha G \theta \int_0^{\tau} i^2 dt,$$

where G denotes the coil constant of the galvanometer, α the induction-coefficient of the needle, θ its (small) initial angular displacement, i the instantaneous value of the current, and τ its duration. The percentage error is accordingly

$$\frac{100\alpha G \theta}{Q} \int_0^{\tau} i^2 dt; \quad (1)$$

and it is of some little interest to inquire whether this may not, on occasion, be so large that it cannot be entirely disregarded.

The value of the coefficient α which enters into (1) is not easily assigned; it may be very large or it may be very small. Since it is equal to the susceptibility of the needle corresponding to the application and removal of a small magnetic force, divided by its intensity of magnetization; and since the former of these quantities increases as the latter diminishes; we see that α will be small if the needle is strongly magnetized, but large if the needle has lost a good deal of its magnetism. For the present purpose it will be sufficient to take α as being $\cdot 002$, a number fairly representative of what

* Communicated by the Author.

one is likely to meet with in a not too feebly magnetized needle.

Magnitude of Error when a Condenser is discharged through the Galvanometer.—When a condenser charged to a difference of potential E and containing a quantity Q is discharged through a galvanometer of resistance R , the whole of the energy, $EQ/2$, stored in the condenser is dissipated in the galvanometer. We may therefore put

$$\int_0^\tau i^2 dt = \frac{EQ}{2R},$$

so that the percentage error becomes

$$50\alpha \cdot \frac{G}{R} \cdot \theta E. \quad \dots \dots \dots (2)$$

For a very sensitive galvanometer wound with copper wire the ratio G/R , expressed in C.G.S. lines per sq. cm. per ampere per ohm, will probably not differ much from unity. For such a galvanometer, therefore, with its needle displaced 1° the error would be only 1 per cent. when $E=600$ volts. But in a less sensitive galvanometer wound with thicker wire G/R may be far larger than unity*—may be as much as 100 in fact; in which case a difference of potential of 6 volts and a displacement of the needle of 1° would suffice to produce an error of 1 per cent. in the throw. A galvanometer in which G/R is as large as 100 is not, it is true, sufficiently sensitive to be well adapted for condenser work; still, with a weak enough controlling field it will give a readable throw when a condenser of a few microfarads capacity charged to 100 volts is discharged through it, and then we might expect to find an error of perhaps 16 per cent. for every degree the needle happens to be displaced.

The expression (2) may be given a different form if we remember that the difference of potential to which a condenser

* For an annular coil of rectangular cross-section (length of coil $2d$ cms., inner radius a_1 cms., outer radius a_2 cms.) wound with wire having a resistance of ρ ohms per cm. the ratio GR is equal to

$$\frac{4}{10\rho d} \left(a_2 - a_1 - d \log_e \frac{a_2 + \sqrt{d^2 + a_2^2}}{a_1 + \sqrt{d^2 + a_1^2}} \right)$$

C.G.S. lines per sq. cm. per ampere per ohm. Thus when $d=1.5$ cms., $a_1=.5$ cm., $a_2=2.5$ cms., G/R is only 7.2 if the coil is wound with No. 40 S.W.G. copper wire, but increases to 500 if No. 19 S.W.G. wire is used.

of capacity C must be charged in order that its discharge through a galvanometer may produce a throw ϕ , is

$$\frac{tH\phi}{2\pi GU'}$$

where t is the time of oscillation of the galvanometer-needle and H is the strength of the controlling field. When this is put for E in (2) it becomes

$$\frac{25\alpha\theta\phi tH}{\pi C} \cdot \frac{1}{R}, \dots \dots \dots (3)$$

showing that for galvanometers with magnetic systems exactly alike and moving in fields equally strong, the percentage error under consideration is inversely as the galvanometer-resistance, the capacity of the condenser discharged, the extent of the throw produced and the initial displacement of the needle being supposed fixed.

Magnitude of Error when a Condenser is charged through the Galvanometer.—The magnitude of the error which occurs on charging a condenser through a galvanometer in the usual way is given by (2). We may, however, arrange the circuit as in fig. 1, and charge the condenser by opening the key K . In this case when the key is closed a current I flows

Fig. 1.

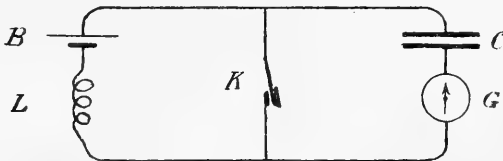

round the circuit KLB which we shall suppose is of inconsiderable resistance but possesses considerable self-inductance L . If the opening of the key occasions no spark, then the energy dissipated in the process of charging is equal to that stored magnetically in the field of the current I at the commencement, together with that stored electrostatically in the condenser at the end; that is, it is equal to

$$\frac{1}{2}(LI^2 + EQ).$$

If the galvanometer be a high-resistance one, practically

the whole of this is dissipated in its coils. Hence

$$\int_0^\tau i^2 dt = \frac{1}{2R} (LI^2 + EQ),$$

which gives

$$\frac{50\alpha G\theta}{QR} (LI^2 + EQ) \dots \dots \dots (4a)$$

for the percentage error.

In an actual experiment carried out on these lines it was so arranged that the second term in the bracket was small compared with the first. The condenser C had a capacity of one-third of a microfarad; the circuit KLB had a self-

Fig. 2.

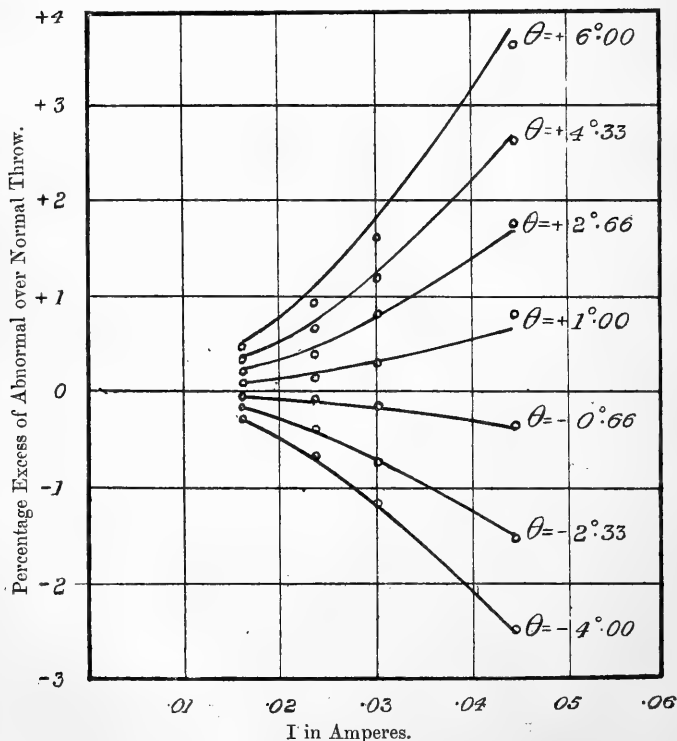

inductance of one-third of a henry; the cell had an electromotive force of two volts; and the resistance of the galvanometer was 6600 ohms, while its coil constant was 3300 C.G.S.

lines per sq. cm. per ampere. By opening K a throw was obtained first with the needle exactly in the coil plane (normal throw), next with the needle turned out of the coil plane by a small angle θ^* (abnormal throw). The difference between these throws expressed as a percentage of the normal throw and plotted against the current I flowing round KLB at the moment of break gave one of the points of fig. 2; and the other points corresponding to other values of θ and of I were obtained in like manner.

On examination it is seen that the whole of these results can be gathered up into the formula

$$\left. \begin{array}{l} \text{Percentage excess of Abnormal} \\ \text{over Normal throw} \end{array} \right\} = 330\theta I^2, \quad . . \quad (4b)$$

where θ is in degrees and I in amperes, θ being regarded as positive when the initial displacement of the needle is in the same direction as the throw, but negative when in the opposite direction.

From a comparison of (4b) with (4a) it is to be inferred that the induction-coefficient of the needle of the particular galvanometer used was .0015, a value not very different from that previously adopted for α .

Owens College, Manchester.

LVI. *On the Sea-Waves connected with the Japanese Earthquake of June 15, 1896.* By CHARLES DAVISON, *Sc.D.*
F.G.S.†

[Plate V.]

THE Japanese earthquake of June 15, 1896, is one that deserves to have its history fully written. So far, it has only been briefly referred to in a few papers ‡, with the

* In reality it was the galvanometer-coil that was turned, the needle being left in a fixed plane and under a fixed controlling field; but it is more convenient to speak, as above, of the displacement of the needle relatively to the coil thought of as fixed.

† Communicated by the Author.

‡ J. Milne, "The Great Sea-Waves in Japan." *Geogr. Journ.* vol. viii. (1896), pp. 157-160.

J. Milne, ["On the Sea-Waves and Earthquakes of June 15, 1896, in North Japan"]. *Brit. Assoc. Report* (1897), pp. 25-31.

F. Omori and K. Hirata, "Earthquake Measurement at Miyako." *Journ. Sci. Coll., Imp. Univ., Tokyo*, vol. xi. (1899), pp. 161-195, especially pp. 164-166, and figs. 1 and 8.

"The Great Seismic Wave in Japan." 'Nature,' vol. liv. (1896), pp. 449-450.

"The Great Disaster in Japan, June 15th, 1896." (A series of articles reprinted from the *Japanese Gazette*, Yokohama.)

exception of a report presented to the Japanese Government, of which no adequate summary has, I believe, appeared in any European language. In the present paper, I shall therefore confine myself to considering the propagation of the sea-waves in an easterly direction, one of my objects being to compare the mean depth of the ocean as obtained by soundings with that obtained from the formula usually employed

$$\sqrt{(gH)} = V,$$

where H is the uniform depth of the ocean in which waves would travel with the same mean velocity V as that of the seismic sea-waves. I have shown in a previous paper* that the value so found must be considerably less than the true mean depth; the calculated value in a particular case considered being 1900 fathoms instead of 2420 fathoms, *i. e.* about $\frac{2}{3}$ of the real value.

In fig. 1 are shown the parts of Central and Northern Japan that were chiefly affected by the earthquake, the town of Kamaishi being practically destroyed by the sea-waves. The continuous curves represent isoseismal lines. Within the curve marked 2, the shock was "weak," the motion being well-pronounced, but not sufficiently severe to cause general alarm; between the two curves 1 and 2 the shock was "slight," and only just strong enough to be felt. The dotted curves are sub-oceanic contour-lines, the figures annexed to each giving the depth in fathoms. According to Mr. T. Iki, the epicentre was situated in lat. 39° N. and long. $144^{\circ} 30'$ E., or about 240 km. E.S.E. of Miyako. It is indicated on the map by a cross, and lies at a depth of 4000 fathoms near the foot of the western slope of the Tuscaroora Deep.

Prof. Omori informs me that the surface-velocity of the earthquake-waves within the disturbed area was about 2.7 km. per second, and, as the time of occurrence at Miyako was 7 h. 32 m. 30 s. P.M. (mean time of 135° E.), this would give 7 h. 31 m. (or 10 h. 31 m. A.M., G.M.T.) as the approximate time at the epicentre. This result is probably correct to within a minute.

Though I made inquiries at all the harbours known to me where self-recording tide-gauges are established, records of the sea-waves appear to have been obtained at only two stations, namely, Honolulu and Sausalito (San Francisco Bay). Copies of these records are given on a reduced scale in fig. 2 and Plate V. For these and for other information given

* Phil. Mag. vol. xliii. (1897), pp. 33-36.

below, I am indebted to the kindness of Prof. W. D. Alexander, Surveyor-General of the (then) Hawaiian Government Survey, of Mr. T. R. Walker, British Vice-Consul at Honolulu, and of Mr. W. W. Duffield, Superintendent of the U.S. Coast and Geodetic Survey.

Fig. 1.

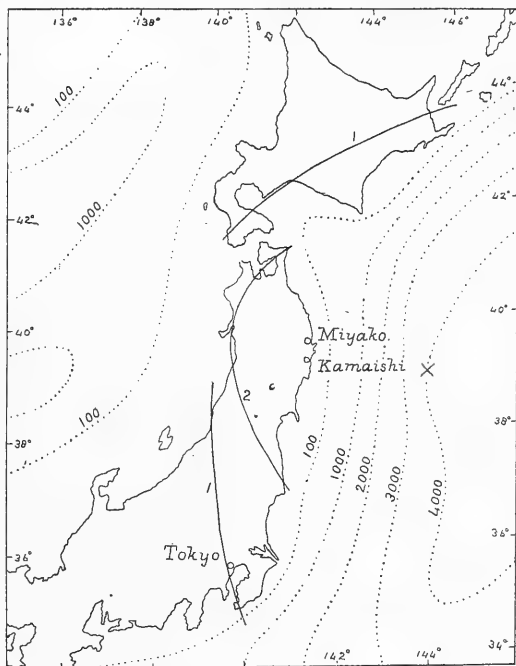

Honolulu (lat. $21^{\circ} 5' N.$, long. $158^{\circ} 0' W.$).—The tide-gauge at this station is one of the Stierle pattern and has been in operation since 1891. The tide-gauge house is on the Esplanade, north-east of the Oceanic Co.'s wharf, where a well was sunk in solid ground to a point below the lowest tides, and connected with the sea by a large horizontal pipe. The scale of the diagram is one inch per hour for the horizontal coordinate, and one inch per foot for vertical displacement. The time is mean local time.

Prof. Alexander writes that "the earthquake-waves were very slightly felt on Oahu and Maui, were more pronounced at Kauai, and reached their maximum on the north coast of Hawaii. The sea rose at Kailua and Keauhou in Kona, Hawaii, eight feet above ordinary high-water mark, flooding

Fig. 2.—Record of Tide-Gauge at Honolulu.

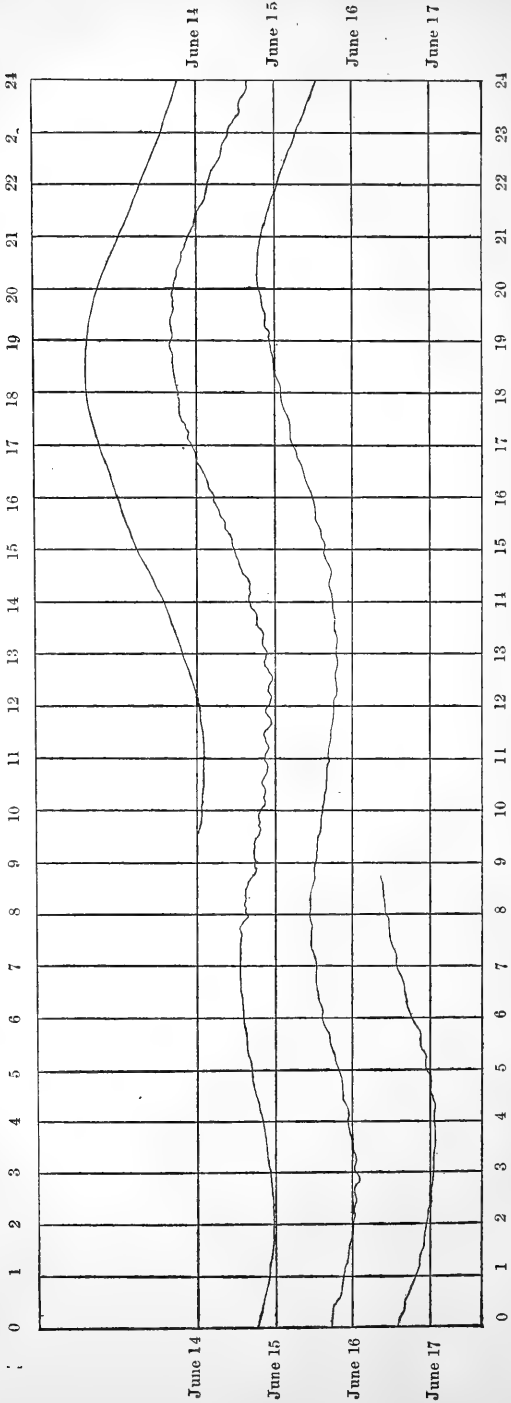

houses, throwing down stone walls, &c. It was reported from there that an extraordinary fall or recession of the sea preceded the greatest wave. No accurate observations seem to have been made in those localities of the times and the number of the prominent waves."

The record at first shows a steady rise and fall of the water; and it is not until 7 h. 37 m. A.M. on June 15 that any change occurs. There is then a small rise of about $\frac{3}{4}$ of an inch, the first crest reaching the gauge at 7 h. 43 m. (*i. e.* at 6 h. 15 m. P.M., G.M.T.). For about two hours this motion is somewhat irregular; but between 9 h. 55 m. A.M. and 5 h. 8 m. P.M. on June 15 there is a group of 17 waves with an average period of $25\frac{1}{2}$ minutes. The waves are all small; they are most marked between 9 h. 55 m. A.M. and 1 h. 40 m. P.M.; and even then the mean distance between crest and hollow of successive waves is only 1.2 inches. The copy of the record closes at 8 P.M. on June 17, when the surface of the water shows signs of returning to its normal steadiness.

The distance between the epicentre and Honolulu, measured along a great circle, is 3591 miles; and, the time-interval being 7 h. 44 m., it follows that the mean velocity was 681 feet per second. If the ocean were of uniform depth between the two points, the depth corresponding to this mean velocity would be 14,492 feet.

Sausalito (lat. $37^{\circ} 51' N.$, long. $122^{\circ} 29' W.$).—Sausalito lies at the entrance to San Francisco Bay. At the time of the earthquake, the gauge here was the only automatic gauge in operation on the Pacific coast of the United States. The scale is .93 inch per hour for the horizontal coordinate (measured from the copy of the record), and 1 inch per foot for vertical displacement. The time is the Pacific standard, that of the 120th meridian west of Greenwich.

In this, as in the Honolulu record, the first evidence of any change is a rise (of 3.7 inches) in the level of the water*, beginning at 12 h. 53 m. P.M. on June 15, the first crest reaching the gauge at 1 h. 5 m. P.M. (*i. e.* at 9 h. 5 m. P.M. G.M.T.). During the first two hours, the waves are larger and of longer period than those which follow, the chief movement being between 1 h. 30 m. and 1 h. 45 m. P.M., when the water rose 6.8 inches and fell 2.2 inches. After this, they become more regular. Between 3 and 6 P.M. there are 30 waves, with an average period of 6 minutes and a mean distance between

* It should be noticed that at two Japanese stations, Ayukawa and Hanasaki-mura, the first movement was a fall in the level of the water. *Nature*, vol. liv. p. 449 (1896).

crest and hollow of successive waves of 1.5 inch. At 1 A.M. on June 17, when the copy of the record ends, there were still very distinct signs of movement due to the Japanese earthquake.

The distance from the epicentre to Sausalito is 4787 miles, the time-interval is 10h. 34m., and the mean velocity between the two places 664 feet per second. On the same assumption as before, the mean depth of the ocean would be 13,778 feet.

Mean Depth of Pacific Ocean as ascertained from Soundings.—I have estimated roughly the depth of the ocean along the two lines from the epicentre to Honolulu and Sausalito, making use for the purpose of the Physical Chart of the World which accompanies the "Narrative" of the Voyage of H.M.S. 'Challenger'*

The epicentre-Honolulu line traverses a part of the ocean whose depth is very variable: indeed, the long chain of islands of which the Hawaiian Islands form the eastern end almost lies along the great circle joining the two places. Along the most direct course which the wave might take, the mean depth is about 13,500 feet. But along a very slight deviation from this line the depth is much greater; and it is probable that the earliest waves which reached Honolulu would take some such course. It is therefore useless to compare this result with that obtained above from the velocity of the seismic sea-wave.

Along the epicentre-Sausalito line the conditions are very different. The great circle joining the two places is entirely free from islands, and crosses the sub-oceanic contour-lines approximately at right angles. The mean depth along this line is more than 17,000 feet, while that obtained from the formula is 13,778 feet, or about $\frac{4}{5}$ of the measured value.

LVII. *On the Law of Partition of Energy.*

By S. H. BURBURY, M.A., F.R.S.†

1. **I**F a material system be defined by the generalized coordinates $q_1 \dots q_n$ with the corresponding momenta $p_1 \dots p_n$, so that the kinetic energy is $\frac{1}{2}(p_1\dot{q}_1 + \dots + p_n\dot{q}_n)$, the law of partition of energy is the relation between the several products $p\dot{q}$ on average of time when the system is in stationary motion. The law of equal partition asserts that, under certain conditions to be investigated, $\overline{p_1\dot{q}_1} = \overline{p_2\dot{q}_2} = \&c.$

* Report on the Scientific Results of the Voyage of H.M.S. 'Challenger,' Narrative, vol. i. pt. 1 (1885).

† Communicated by the Author.

or the mean kinetic energy is the same for each degree of freedom.

In this paper I propose to deal with the theory only as it relates to velocities of translation. If the system consist of molecules having masses M and m , and if U, u are their respective velocities, then the law of equal partition assumes the form

$$m\overline{u^2} = M\overline{U^2} = \&c.$$

2. *A necessary qualification.*—The energy of translation which is to be the subject of equal partition will be understood not to include that of any common velocity which the molecules may have—for instance the earth's motion in space—or of any sensible stream motion. I maintain further that in addition to sensible streams there exists generally what may be called a molecular stream—that is, that molecules very near each other in space have on average a certain velocity in common. But that this applies only to distances comparable with the dimensions, or with the radius of action, of a molecule. It cannot therefore, any more than individual molecules themselves, be the subject of observation. The existence of such molecular streams is, as I maintain, when intermolecular forces exist or the molecules have finite dimensions, an analytical condition of stationary motion. If that be true, we may perhaps find that the energy which is to be the subject of partition should be exclusive of the energy of the molecular stream as well as of the energy of all sensible streams.

The necessary Condition.

3. It is a necessary condition for our law that the motion be stationary. But that is not a sufficient condition, for it is possible to construct systems which are in stationary motion without satisfying the law. As, I think, Lord Kelvin has done in his "decisive test case." Some other condition must then be satisfied besides that of stationary motion. What is that other condition? Before we can either prove or disprove the law, we require an enunciation of it.

So far as I know we have only to choose between Maxwell's condition (Cambridge Phil. Soc. Trans. xii., p. 648) and Boltzmann's, as given in his *Vorlesungen über Gas Theorie*. Let us first consider Maxwell's, as expounded by Lord Rayleigh in Phil. Mag. January 1900.

Maxwell's Condition.

4. Maxwell and Rayleigh maintain that the only assumption necessary for the truth of the law is that the system, if
Phil. Mag. S. 5. Vol. 50. No. 307. Dec. 1900. 2 T

left to itself, will sooner or later pass through every phase consistent with the conservation of energy (Maxwell's paper, p. 548). It must therefore sooner or later return to its first state, the motion being in fact cyclic. Further the motion is evidently reversible.

5. The line of argument is sufficiently shown in Rayleigh's treatment (Phil. Mag. January 1900, pp. 102-107) of the system of particles moving in two dimensions in a field of force. He defines as follows:—(1) If x, y denote the coordinates, u, v the component velocities of a particle, then, when $x y u v$ lie within the limits $x \dots x + dx \dots \dots \dots v \dots v + dv$, the particle is in the phase $(x y u v)$. (2) $f(x y u v) dx dy du dv$ is the number of particles which at any instant are in the phase $(x y u v)$. The path of any system, and of any one of Rayleigh's particles as a particular case, is the series of successive states through which the system passes in unguided motion with total energy constant. The path in which the total energy is E may be called the path E . Then, argues Rayleigh, the particles which at a given instant ($t = 0$) are in the phase $(x y u v)$ are the identical particles which will at time t be in the phase $(x' y' u' v')$, and no other particles will at time t be in the last mentioned phase. Therefore

$$f(x y u v) dx dy du dv = f(x' y' u' v') dx' dy' du' dv'.$$

But by a known theorem, which owes much to Rayleigh,

$$dx dy du dv = dx' dy' du' dv'.$$

Therefore

$$f(x y u v) = f(x' y' u' v'), \text{ or shortly } f = f'.$$

That is, the number of particles which initially are in the phase $(x y u v)$ is equal to the number which after time t will be in the phase $(x' y' u' v')$. If therefore there be at the initial instant the same number of particles in every phase of the path E , the motion will as regards these particles be stationary.

In stationary motion, then, f is constant for all phases on the same path. E is also constant for all phases on the same path, and we will assume for the present with Rayleigh that it is the only other constant. We will now assume that there are many particles on the same path for each of which E is constant, and many paths for each of which f and E are constants, and no other thing is constant; but E , and it may be f , will vary between one path and another. It follows that f is a function of E . Now $E = V + T$, where V is a function of the coordinates, and T , the kinetic energy,

is a quadratic function of the velocities which define a phase for the same particle, and of those velocities only. That is, given x and y , f is a function of $(u^2 + v^2)$. It follows that for each of Rayleigh's particles $\overline{u^2} = \overline{v^2}$.

6. But if particles of one system have mass m , and those of another system m' , and their respective velocities are u u' , no conclusion can be drawn as to the relation between $m\overline{u^2}$ and $m'\overline{u'^2}$. For we have two alternatives: (1) The particles do not undergo collisions or encounters with each other, whereby a particle would gain or lose energy, and so change its path; or (2) such encounters do take place. If we choose alternative (1), every distribution of energy between the classes m and m' is permanent. If we choose alternative (2), the method fails to prove that $f = f'$, and is inapplicable.

7. Rayleigh's method is easily generalized as follows:— Instead of a particle moving in two dimensions, the system may be a particle or elastic sphere in three dimensions. Or it may be defined by n generalized coordinates $q_1 \dots q_n$ with the corresponding momenta $p_1 \dots p_n$. And we may denote by $f(q, p) dq_1 \dots dp_n$ the number of systems which are in the phase (q, p) . It then follows on precisely the same conditions as in the case of the particles in two dimensions, that f is constant throughout a path. Also E is constant. And if E be the only other constant, f is a function of E , that is of $V + T$, say $f = \phi(E)$.

In this general case Rayleigh argues that T can always be expressed in terms of squares of the velocities, as

$$T = A_1 \dot{q}_1^2 + A_2 \dot{q}_2^2 + \&c.$$

I pass over this discussion, because it does not concern translation velocities, with which alone I am dealing. Hence follows, that if \dot{q}_1 \dot{q}_2 &c. define a phase of any system,

$$A_1 \overline{\dot{q}_1^2} = A_2 \overline{\dot{q}_2^2} = \&c.$$

The result is proved—if it is proved—only for velocities which belong to *the same system*, while each system fulfils Maxwell's condition.

8. If therefore we are to prove by Rayleigh's method that, for different masses m and M , $m\overline{u^2} = M\overline{U^2}$, we must make u and U velocities of *the same system*, one of a class of systems to which Maxwell's principle is assumed to apply. I take the simplest case. The system consists of two elastic spheres whose masses are m and M , and whose velocities are u v w and U V W respectively. To simplify matters further, we will assume the field of force to be uniform.

If the two spheres composing a "system" collide *with each other*, the "system" remains on the same path before, during, and after that collision, only the phase changing. But if either sphere collides *with a third sphere*, the "system" changes its energy, and therefore its path. In this case no pair of spheres or "system" passes on the same path through all phases consistent with conservation of energy. Rayleigh's argument is therefore inapplicable to systems of this description.

9. It is to be noted also that, even if we regard the system only while it continues on the same path, during an interval which includes a collision between m and M , the reasoning still fails because E is not the only constant before and after collision. The square of the relative velocity R of m and M is also constant, namely

$$R^2 = (u - U)^2 + (v - V)^2 + (w - W)^2.$$

Therefore f is a function, not of E only, but of E and R^2 .

And for the same reason I think it must fail as applied to the translation velocities of any group of spheres, because E will always have a companion constant representing conservation of momentum.

It is useful here to compare Rayleigh's equation $f = f'$ with that which Boltzmann obtains in the corresponding case, namely $Ff = F'f'$. In Boltzmann's notation F, F' relate to M spheres before and after collision, and f, f' similarly relate to m spheres. Rayleigh's equation admits of solution in the form

$$f = A\epsilon^{-h(T + KR^2)},$$

where A and K are constants. Boltzmann's equation admits of no solution for our present purpose except

$$Ff = A\epsilon^{-hT}.$$

Boltzmann, if his fundamental assumptions are true, proves the law $m\bar{u}^2 = M\bar{U}^2$, while Rayleigh's method if applied to any finite group of spheres as a "system" fails to prove it.

10. In order rightly to apply Rayleigh's argument, we must treat as one "system" all the elastic spheres (if our molecules are such) in the field. Or it must be a material system, which, however its parts may act on each other, is, and for ever remains, subject to no external influences. And it passes in cycle through all phases which can be reached from its initial phase with E constant. I think we have no cage for such a bird.

Nevertheless Rayleigh's reasoning, or Maxwell's pp. 553-554, must be accepted as proving that throughout the path

of the imaginary system f is constant. I think that $f(q, p)$ in case of a single system represents the time during which, on an average of the cycle, it is in the phase (q, p) . If then E be the only other constant, we should have $f = \phi(E)$, and that would, as it seems to me at present, lead to the law of equal partition.

With great reluctance I am compelled here to differ from these high authorities. I think the method as a whole fails. Firstly because Maxwell's conditions are not fulfilled by any existing system. Secondly because, given Maxwell's condition alone, we have no right to assume E to be the only constant. Every system must, to go no further, have constant parameters; for instance (1) the masses $m_1, m_2, \&c.$, of its molecules, (2) their force constants $\mu_1, \mu_2, \&c.$, if they are centres of finite force, (3) their radii $c_1, c_2, \&c.$, in the limiting case of elastic spheres. These parameters should *prima facie* appear in f . Now m and μ do appear in E , and therefore in f as a function of E . But why may we assume that they appear in that form only? And why may we assume that in the limiting case of elastic spheres the c 's do not appear at all? These restrictions on the form of f are indeed justified mathematically by Boltzmann's method, if his fundamental assumption be true, and our habit of accepting them as proved by Boltzmann predisposes us to accept them when assumed in a totally different case. I think, however, they cannot be justified in any other way than by Boltzmann's method. At all events Maxwell's principle, taken, as we are ordered to take it, alone, seems to me not to justify them.

Boltzmann's Assumption.

11. Boltzmann formally announces that he shall assume that the motion of his molecules is, and for all time continues to be "molecular ungeordnet." This expression is intended to define some property which the system possesses. It cannot be, and in fact is not, used as a substantive assumption. For any special case a separate assumption has to be made, which may be regarded as the interpretation of "molecular ungeordnet" as applied to the special case in question.

In the case of elastic spheres or binary encounters generally, the thing assumed is as follows:—

The number per unit of volume of spheres of mass M , whose velocities lie between the limits

$$\left. \begin{array}{l} U \quad . \quad . \quad U + dU \\ V \quad . \quad . \quad V + dV \\ W \quad . \quad . \quad W + dW \end{array} \right\} A,$$

shall be $F(U V W)dU dV dW$, or shortly $F dU dV dW$. We may call these spheres of the class F.

Similarly $f du dv dw$ is the number per unit of volume of spheres of mass m , whose velocities lie between the limits

$$\left. \begin{array}{lll} u & . & . & u + du \\ v & . & . & v + dv \\ w & . & . & w + dw \end{array} \right\} a.$$

We may call these spheres of the class f .

Boltzmann now assumes that the number of collisions which take place per unit of volume and time between spheres of class F and spheres of class f , and in which the coordinates defining the relative position are within defined limits $d\sigma$, is

$$FfR dU dV dW du dv dw d\sigma,$$

where

$$R^2 = (U - u)^2 + (V - v)^2 + (W - w)^2.$$

That is, he assumes that the chance of a sphere M having velocities within the limits A is independent of the position and of the velocities of the sphere m, however near the two spheres may be to one another. This we may call the condition of independence. It is assumed by necessary implication for all pairs of molecules approaching collision with each other.

12. Having made or implied this assumption, Boltzmann from this point onward works rigorously. The truth of his result depends on the truth of the above assumption.

By a collision of the kind last described the two spheres pass respectively into the classes F' and f' , the numbers of which are $F'dU'dV'dW'$ and $f'du'dv'dw'$. And by a process so well known that I need not here set it out, he deduces the H theorem. According to this theorem

$$\frac{dH}{dt} = \iiint_{-\infty}^{+\infty} (F'f' - Ff)R \log \frac{Ff}{F'f'} du dv dw dU dV dW,$$

which is necessarily negative if not zero, and then only zero when $F'f' = Ff$ for all cases in which a pair of spheres can pass by collision from the classes Ff to the classes $F'f'$ or *vice versa*. And the solution of the equation $F'f' = Ff$ involves, if there be no stream-velocity,

$$F = C\epsilon^{-hM(U^2 + V^2 + W^2)}, \quad f = c\epsilon^{-hm(u^2 + v^2 + w^2)},$$

whence we deduce

$$\overline{mu^2} = M\overline{U^2}, \text{ \&c.}$$

13. The result thus proved by Boltzmann, if his fundamental assumption is true, is that the motion is *irreversible*

and *asymptotic*. Maxwell and Rayleigh on the other hand assume it to be *cyclic* and *reversible*. If, therefore, Boltzmann is right, Maxwell and Rayleigh are wrong. If Maxwell and Rayleigh are right in their assumption, Boltzmann must be wrong—that is, his assumption must be untrue, for the proof founded on it is irrefragable. This, I think, is the true state of the case. But it will not make Maxwell and Rayleigh right, either their assumption or the proof founded on it.

14. The law of equal partition in the form $m\bar{u}^2 = M\bar{U}^2$ has been proved by many writers in many ways. But with the exception of Maxwell and Rayleigh, who (I think) fail to prove the law at all, every one bases his proof expressly or by implication on the assumption of independence, as does Boltzmann. And all these proofs stand or fall with Boltzmann's. No one has yet pointed out how the assumption of the molecular ungeordnet state can be directly used in argument, or how it differs from the implied assumption of independence.

15. The assumption of the independence of the chances (art. 11) is, as I maintain, untrue. A motion is surely conceivable in which molecules very near each other have on average a certain velocity in common. I think this is a necessary consequence of the existence of intermolecular forces. It is probably true of a liquid. Why not in some degree of a gas? But Boltzmann by his fundamental assumption excludes from consideration all cases of this kind. He does not prove their non-existence, he takes it for granted.

16. In order to express the possibility of such a motion, we must represent the law of distribution of the velocities $u_1 v_1 w_1 \dots w_n$ of our molecules (at any given level of potential if they be in a field of external force) by the exponential $\epsilon^{-hQ} du_1 \dots dw_n$. Here Q contains not squares of the velocities $u_1 v_1 \dots w_n$ only, as in Boltzmann's theory, but is a quadratic function comprising also products of the form $uv', v'w', ww'$. The object ought to be to keep these products in, not to keep them out.

On the Law of Equal Partition if Boltzmann's assumption be not made.

17. I will now show what on this hypothesis becomes of the law of equal partition of energy. I do this firstly to obtain a more general result from which Boltzmann's can be deduced as a particular case. Secondly, to show how little we gain in ease of analysis by omitting the products from

Q, and so sacrificing the generality of the theorem. I will assume for this purpose that

$$\begin{aligned} Q &= m_1(u_1^2 + v_1^2 + w_1^2) + m_2(u_2^2 + v_2^2 + w_2^2) + \&c. \\ &+ (m_1 + m_2)b_{12}(u_1u_2 + v_1v_2 + w_1w_2) + \&c. \\ &+ (m_p + m_q)b_{pq}(u_pu_q + v_pv_q + w_pw_q) + \&c. \end{aligned}$$

Here m_1m_2 &c. denote the masses, $u_1v_1w_1$ &c. the component velocities of the molecules, and b_{pq} or b_{qp} is a function of the distance r_{pq} at the instant considered between the molecules m_p and m_q , which function is of negative sign, decreases in absolute magnitude as r increases, and becomes evanescent for values of r which may themselves be small beyond the limits of observation. It is not necessary for the present purpose to determine their form.

18. We first prove that

$$u_1 \frac{dQ}{du_1} = u_2 \frac{dQ}{du_2} = \&c.$$

on average. For

$$\frac{dQ}{du_1} = 2m_1u_1 + (m_1 + m_2)b_{12}u_2 + (m_1 + m_3)b_{13}u_3 + \&c.$$

The mean value of $\frac{dQ}{du_1}$, u_1 being supposed given, is

$$\iiint_{-\infty}^{+\infty} \dots du_2 \dots du_n \epsilon^{-\lambda Q} \frac{dQ}{du_1}.$$

Since Q contains no products of the form uv or uw , we need not take the v 's and w 's into consideration in forming this mean value. The result of the integration is as follows: Let D denote the determinant

$$D = \begin{vmatrix} 2m_1 & (m_1 + m_2)b_{12} & (m_1 + m_3)b_{13} & \dots \\ (m_1 + m_2)b_{12} & 2m_2 & (m_2 + m_3)b_{23} & \dots \\ \dots & \dots & \dots & \dots \end{vmatrix}$$

and let D_{11} , D_{22} , &c. be its coaxial minors. Then, given u_1 , $\frac{dQ}{du_1}$ has for its mean value $\frac{D}{D_{11}}u_1$, and $u_1 \frac{dQ}{du_1}$ has for its mean value $\frac{D}{D_{11}}u_1^2$.

To find the general mean value $\overline{u_1 \frac{dQ}{du_1}}$ when u_1 also varies, we must write for u_1^2 its mean value. But that is

$\frac{D_{11}}{D} \frac{1}{2h}$. Hence

$$\begin{aligned} \overline{u_1 \frac{dQ}{du_1}} &= \frac{D}{D_{11}} \frac{1}{2h} \frac{D_{11}}{D} \\ &= \frac{1}{2h}. \end{aligned}$$

Similarly

$$\overline{u_2 \frac{dQ}{du_2}} = \frac{1}{2h} \text{ \&c.}$$

And therefore

$$\left. \begin{aligned} \overline{u_1 \frac{dQ}{du_1}} &= \overline{u_2 \frac{dQ}{du_2}} = \text{\&c.} \\ \overline{u \frac{dQ}{du}} &= \overline{v \frac{dQ}{dv}} = \overline{w \frac{dQ}{dw}} \end{aligned} \right\} \dots \dots \dots \text{(A)}$$

And of course

19. Let us now write

$$\begin{aligned} -\xi_1 &= (m_1 + m_2)b_{12}u_2 + (m_1 + m_3)b_{13}u_3 + \text{\&c.} \\ -\eta_1 &= (m_1 + m_2)b_{12}v_2 + (m_1 + m_3)b_{13}v_3 + \text{\&c.} \\ -\zeta_1 &= (m_1 + m_2)b_{12}w_2 + (m_1 + m_3)b_{13}w_3 + \text{\&c.} \end{aligned}$$

Similarly

$$\begin{aligned} -\xi_2 &= (m_2 + m_1)b_{12}u_1 + (m_2 + m_3)b_{23}u_3 + \text{\&c.} \\ &\text{\&c.} \end{aligned}$$

Then

$$Q = \Sigma m(u^2 + v^2 + w^2) - \frac{1}{2} \Sigma (u\xi + v\eta + w\zeta),$$

the summation including all molecules. The factor $\frac{1}{2}$ comes in because in $\Sigma (u\xi + v\eta + w\zeta)$ every product as $m_1 b_{12} u_1 u_2$ occurs twice.

Our equations

$$\overline{u_1 \frac{dQ}{du_1}} = \overline{u_2 \frac{dQ}{du_2}} = \text{\&c.}$$

now become

$$m_1 \overline{u_1^2} - \frac{1}{2} \overline{u_1 \xi_1} = m_2 \overline{u_2^2} - \frac{1}{2} \overline{u_2 \xi_2} = \text{\&c.} \quad \dots \quad \text{(B)}$$

These are the equations which take the place of

$$m_1 \overline{u_1^2} = m_2 \overline{u_2^2}, \text{ \&c.,}$$

and we have to consider the significance of these equations B as bearing on the law of equal partition of energy.

20. Now (I.) if we could prove that the ratios $\overline{u\xi}/m\overline{u^2}$, $\overline{v\eta}/m\overline{v^2}$, &c. are the same for each molecule, we should have

established the law in the form $m\bar{u}^2 = m'\bar{u}'^2$. But these relations cannot be true generally, because the coefficients b are functions of the diameters of the molecules if elastic spheres, or of their radius of action if centres of force. The law is therefore not generally true in the form $m\bar{u}^2 = m'\bar{u}'^2$.

The following method suggests itself:—

Since Q is constant we have

$$\Sigma \left(\frac{dQ}{du} \frac{du}{dt} + \frac{dQ}{dv} \frac{dv}{dt} + \frac{dQ}{dw} \frac{dw}{dt} \right) = 0.$$

Also by conservation of energy

$$\Sigma \left(mu \frac{du}{dt} + mv \frac{dv}{dt} + mw \frac{dw}{dt} \right) = 0.$$

If we can deduce $\frac{dQ}{du} \propto mu$, &c., this together with A proves the law of equal partition. I think, however, the deduction is unsound, for the reasons given above, and at p. 102 of my "Treatise on the Kinetic Theory of Gases."

II. By introducing the coefficients b in the index Q we have given to any two molecules very near each other a common velocity on average, and so diminished the energy of the motion of any molecule m_1 relative to its neighbours. If we prove that the amount by which the energy of this relative motion is diminished is $\frac{1}{2}(\overline{u_1\xi_1} + \overline{v_1\eta_1} + \overline{w_1\xi_1})$, this expression would denote the energy of the stream. And now our equations (B) would express the law of equal partition in the only sense in which we could expect it to be true (see art. 2)—that is, as exclusive of the energy of the stream.

But in fact $\frac{1}{2}(\overline{u_1\xi_1} + \overline{v_1\eta_1} + \overline{w_1\xi_1})$ does not express the loss of energy of the motion of m_1 relative to its neighbours, and therefore does not express the energy of the stream. To see this it is sufficient to consider the case in which all the molecules have the same mass. Then the energy of relative motion in question is for m_1

$$\frac{1}{2}m_1R_1^2 = \frac{1}{2}m_1 \left\{ (u_1 - u')^2 + (v_1 - v')^2 + (w_1 - w')^2 \right\},$$

where all molecules except m_1 are included in the summation for u' , v' , w' .—That is,

$$\frac{1}{2}m_1R_1^2 = \frac{1}{2}m_1\Sigma \left\{ (u^2 + u'^2) + (v^2 + v'^2) + (w^2 + w'^2) \right\} \\ - m_1\Sigma (uu' + vv' + ww').$$

If every b is zero the last term is zero. The loss of the energy of relative motion due to the b coefficients is therefore

$$m_1\Sigma (uu' + vv' + ww'),$$

which is no longer zero when the b 's are not zero.

The mean value of this expression for $u_1u_2 + v_1v_2 + w_1w_2$ is $\frac{3}{2h} \frac{D_{12}}{D}$, where D_{12} denotes the anaxial minor of D_1 , and contains terms in the first degree of the b 's. But now

$$u_1\xi_1 = (m_1 + m_2)b_{12}u_1u_2 + \&c.$$

And if we form $\overline{u_1u_2}$ in the same way, the expression will contain only second and higher powers of the b 's. It follows that $\Sigma(u\xi + v\eta + w\zeta)$ does not represent the stream energy. And therefore the law of equal partition is not proved in the sense above explained.

If, however, as a mere question of definition, and "without prejudice" to the facts, we call $\frac{1}{2}(u_1\xi_1 + v_1\eta_1 + w_1\zeta_1)$ the energy of stream-motion for m_1 , there is much to be said for the definition. By so doing we should in a measure preserve the symmetry, while unable to maintain the accuracy, of the Maxwell-Boltzmann theory of equal partition of energy.

21. I think the conclusions to be drawn are as follows:—

I. The law of equal partition of energy among the translation velocities is not proved by the Maxwell-Rayleigh method.

II. It is not proved by Boltzmann's method, because the fundamental assumption on which that method is based is not proved.

III. Subject to any proof that may be given hereafter of Boltzmann's assumption, which, however, I think can be disproved, the law is not generally true in any sense whatever. When, however, the density is very small, mu^2 will differ from $m'u'^2$ only by small quantities of the second order.

The law may therefore be asserted for the limiting case of an infinitely rare gas.

LVIII. *The Rates of a Rocking Watch, with Remarks on a Gravitational Pendulum.* By C. BARUS*.

(1) **A**FTER mounting the works of an old watch in a hard-wood ring, I noticed that the period of the watch and case when suspended loosely from a pin a (afterwards, see fig. 4, replaced by a knife-edge), was almost identical with that of the balance-wheel. As a result, the watch when left to itself rocked permanently to and fro, the excursions amounting to as much as 9° , in later experi-

* Communicated by the Author.

ments under proper adjustment* to over 18° . They were thus strikingly visible across a large room even without an attached index. It occurred to me that such an arrangement could be made to possess considerable didactic and possibly practical interest, being not only a capital illustration of the principle of resonance and of the principle of areas, but lending itself at once to a more serious study of the interference of two nearly synchronous vibrations with each other. A very perfect system of two degrees of freedom undergoing forced vibration is presented for inspection: for the watch is a recording instrument, and whatever period supervenes under given conditions is found from the dial in comparison with a chronometer, also a recording instrument.

With regard to the motion one may infer in a partial way that the inertia of the balance-wheel will be apparently increased or diminished according as the period of the watch is above or below the normal period of the former (about $\frac{1}{5}$ second). While the balance-wheel, apart from friction, is a simple harmonic pendulum for all excursions, the watch is not rigorously so, but shows a longer or shorter natural period, depending on greater or smaller elongations within the limits of observation. This is an additional peculiarity giving further scope to the instrument.

On adding a suitable ballast at *b* (fig. 4), beats were naturally obtained often striking in character. But a singular feature was observed in these experiments: while beating was marked at the outset, no adjustment was found which made these beats permanent. They invariably vanished gradually in the lapse of time, usually into the uniform harmonic motion of smaller amplitude and period. These and other circumstances induced me to follow the phenomenon carefully, and in the following table I have recorded a selection of the results obtained in so far as they deserve notice.

The watch was mounted on a steel knife-edge and swung from hard steel plates (an old horseshoe-magnet). It was removed once in 24 hours to be rewound, though sometimes 36 hours were allowed to elapse. Comparisons were made with a good chronometer in the morning and evening to seconds, this being much greater accuracy than the watch warranted.

(2) Since the centre of gravity of the watch is approximately determinable by trial, and its period known, the moment

* Much larger angles could have been obtained had the adjustment permitted. Apart from this and friction &c. there is no near limit.

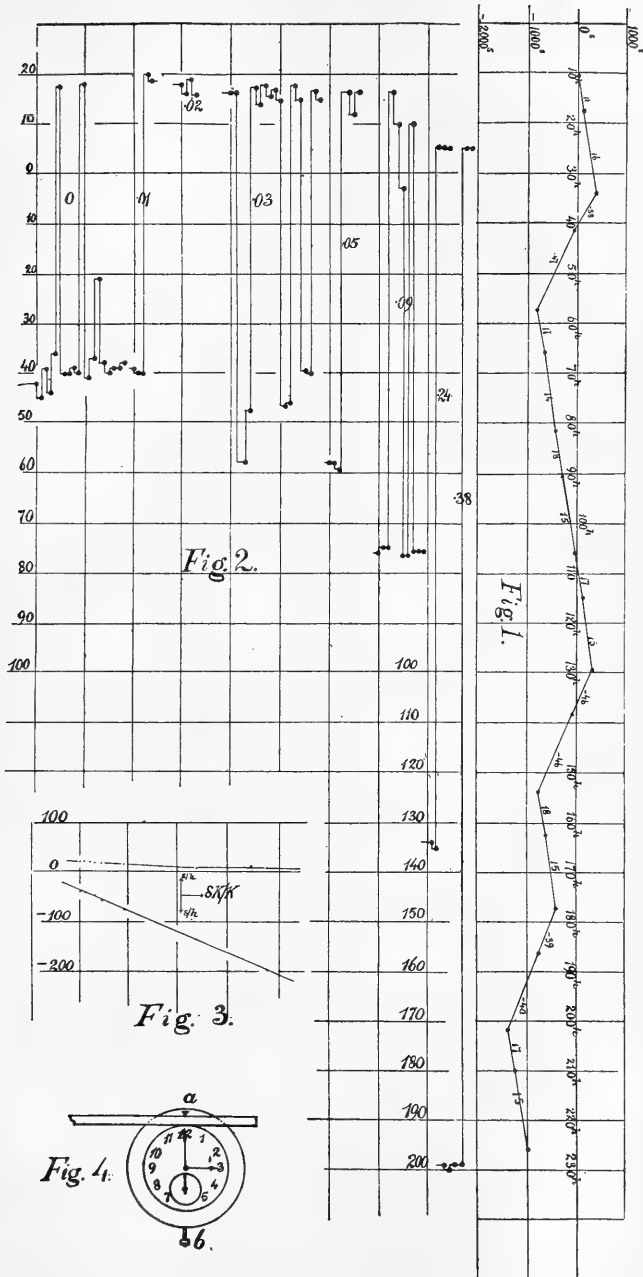

of inertia, k , of the watch without ballast is easily found from its mass (65.874). In this way, roughly, $k=681 \text{ g.cm.}^2$. The increments of moment of inertia, δk , were directly computed. They were produced by successively increasing small metallic masses, all added at a distance of about 6 cm. below the knife-edge.

The table, which is an example of a single series of observations, is otherwise clear. The rates are given in seconds per hour of the chronometer (time in hours and fractions of an hour) for each pair of consecutive observations, since this method lends itself well for description in the annexed chart, where curve I. shows the advance of the watch (ordinate) in terms of the chronometer time (abscissa). The given series applies for an added ballast, increasing the inertia k about 3 per cent. The rates are inscribed on the successive branches of the curve. It will be seen that two typical rates, respectively positive and negative, are involved.

TABLE I.—Time and successive rates of the rocking watch.
 $k=681 \text{ g.cm.}^2$ Ballast added 6 cm. below knife-edge.

Ballast.	Chronometer (hours).	Advance of watch (sec.).	Successive rates (sec./hour).	Average rate: long period.	Average rate: short period.
$\delta k=20 \text{ g.cm.}^2$	10:34	— 13		—46.0 s./h.	+16.1 s./h.
	17:78	+ 110	+16		
$\delta k/k=03$	33:83	+ 373	+16		
	41:07	— 45	—58		
	57:35	— 821	—48		
	65:88	— 672	+17		
	81:75	— 443	+14		
	90:28	— 283	+18		
	105:72	— 49	+15		
	114:82	+ 108	+17		
	129:32	+ 322	+15		
	138:10	— 86	—46		
	153:53	— 795	—46		
	162:33	— 636	+18		
	177:27	— 415	+15		
	186:30	— 772	—39		
	201:40	— 1378	—40		
	209:62	— 1236	+17		
	225:58	— 996	+15		

The rates obtained in all the different series for successive increments of the moment of inertia are given in Table II. and in the corresponding chart, fig. 2. For convenience in plotting, the successive observations are supposed to have

been taken at equal intervals of time apart. The figure brings out the long period (negative rate) and the short period (positive rate) very well. The relative increment, $\delta k/k$, of moment of inertia is inscribed on each curve. Considerable fluctuation is observed in all the individual rates, due to the imperfect watch, for they remain when the watch is fixed. Sometimes definitely intermediate values (as under $\delta k/k=0$) are in evidence, due to the spontaneous change of the mode of vibration from the long to the short period, the nature of which I will indicate below.

TABLE II.—Relation of $\delta k/k$ to rate corresponding to the long period and to the short period.

$\delta k/k$.	Rate of long period : sec./hour.	Ratio of increments*.	Rate of short period : sec./hour.	Ratio of increments*.
·000	— 39·8	— 4·2	+ 17·5	+ ·6
·013	— 39·7		18·5	
·023	...		17·1	
·030	— 46·0		16·1	
·046	— 58·3		15·0	
·091	— 75·3		13·2	
·240	— 135·0		5·0	
·380	— 199·3		5·0	

Finally, if the successive rates be plotted in their dependence on the change of moment of inertia ($\delta k/k$) due to the ballast† added, the curves fig. 3 will be obtained. Within the limits imposed by the errors of the watch and the errors of observation both are nearly straight lines, the values for the long period being much more clear-cut than those for the short period. These values are also given in Table II., from which it appears that numerically the rate for the long period increases 4·2 seconds per hour for each per cent. of relative increment ($\delta k/k$) of the moment of inertia of the watch. The rate for the short period decreases on the average about ·6 sec./hour for each per cent. of $\delta k/k$, within the greater part of the range observed. Here, however, the approach to a limit is definitely manifested.

(3) The theory of a system of two degrees of freedom is given by Lord Rayleigh in the fifth chapter of 'Sound,'

* $\delta k/k$ in per cents.

† I have expressed the rates in terms of the increments of moment of inertia for convenience. It should not be overlooked that ballast increases the gravitational torque.

§§ 112-118. The inferences to be drawn when the system is assimilated to the case of a single degree of freedom are adduced in the third chapter. Inasmuch as I purpose merely to present the above observations as an interesting illustration of the general theory, having a possible practical application, a few remarks will suffice for guidance.

The present system of two degrees of freedom may vibrate permanently in one of two ways: either the balance-wheel and the pendulum (watch) vibrate in the same phase, in which case the torque of the hair-spring is slowly paid out, and there will be a long period and a long swing of the pendulum; or the two elements vibrate in opposed phases, in which case torque is rapidly expended, the common period is short, and the arc of vibration small. The long period may usually be established from a sweeping swing of the pendulum, while the short period is reached spontaneously from rest. The adjustment is often difficult; as a consequence the two periods occur in the curves in irregular succession, the attempted predisposition having failed (*cf.* fig. 1). The two compound periods found were invariably different. If the two component periods are not equal, there can be no proportionality between corresponding terms in the Lagrangian function. If they are equal this can take place only for one arc of vibration of the pendulum. Beyond this the case is actually one of forced vibrations, and the energy of the system receives a regular accession from the escapement.

The treatment of the problem involves the consideration of four frequencies; the two belonging to the compound free system as observed above, and the two individual frequencies of the component elements, the balance-wheel and the pendulum, when vibrating alone. I have already called these compound and component frequencies respectively. They must be so grouped in relative magnitude that the two latter lie within the limits of the two former, while an increase of the inertia of the system (ballast) increases both periods.

In the observations above the period of the pendulum alone is successively increased, whereas the period of the balance alone is left unchanged. Hence the long period of the system, which must exceed that of the watch, is successively pushed forward to infinity. The short period of the system, remaining ever smaller than that of the balance alone, is also increased gradually to reach the limit given by the fixed period of the balance-wheel stated: *i. e.*, the limit corresponding to the normal rate of the watch at rest. In the experiments, the occurrence of the two compound periods and their variations is remarkably well shown, the compound

rates being respectively increasingly slower and diminishingly faster than the chronometer. In fig. 3, the curve of long periods marches rapidly to $-\infty$, the other is asymptotic to a horizontal line at 5 sec./hour, the normal rate. The tendency of the positive rates to reach a limit on the right is borne out by the observations. The remarkably linear character of the negative rates, however, is somewhat perplexing; for if both curves be prolonged to the left, the negative rates should tend toward the asymptote $+5$ sec./hour (watch at rest), while the positive rates with continually decreasing ballast should tend towards positive infinity. When the component period of the pendulum falls below that of the balance-wheel, both compound rates would soon be positive and the larger positive rates become the more variable. The appearance of the observation curves (fig. 3) is such as would lead one to suspect an intersection when $\delta k/k = -\cdot 15$; *i. e.* when the inertia of the watch has been reduced 15 per cent. I regret that the character of the mounting did not enable me to enter the negative field with the object of exhibiting the curves in full, in both directions.

(4) In the case of the long period no beating was observed or producible. The component periods are increasingly different as δk increases. The overwhelming inertia of the watch in this case completely controls the motion of the balance-wheel. To obtain beats the balance-wheel must be given an advantage by starting the pendulum as nearly as possible from rest. In the case of the short period started with a moderate arc of vibration, beating is almost an invariable accompaniment of the incipient motion. As a first approximation the system may be compared with the case of a single degree of freedom, undergoing forced vibrations imposed by the escapement, eventually to respond permanently to the modified period of the balance-wheel. Meanwhile, however, the independent simple harmonic motion of the pendulum evoked on starting is vanishing exponentially. The observed beating is an interference of the two sets of vibrations of nearly the same period. When the pendulum vibrations proper have run their course beating ceases.

This explanation can only be partial, since it implies the existence of but one compound period instead of two, and since beats are particularly marked when the pendulum is started from rest. They occur during the period of mutual reaction, while the balance-wheel is stimulating the clock to vibrate permanently in the smaller period, and they appear as a hovering around the period of equilibrium which is very

gradually established*. While the occurrence of beats in a system of two degrees of freedom presents no novelty, the evanescent character of the beating in the above apparatus is to be pointed out. In order to make the two component periods more nearly the same, ballast would have to be removed from the watch. As I did not do this I cannot say whether beating in such a case would be more permanent.

(5) The exceptional or intermediate periods are an average between the two free compound periods, and are produced when the system swings part of the time between successive observations in one mode and part of the time in the other. At first I was inclined to regard this transition from one possible mode to the other as due to incidental influences (air-currents, jar, temperature). It is probable, however, that the case is to be sought in the mechanism itself, and due to a change in the natural period of the balance-wheel according as the watch is more or less run down. Thus during an interval of 36 hours, the watch at rest changed its rate from +5 sec./hour during the first 12 hours, to -4 sec./hour during the last 12 hours. Conformably with this I noted that when the watch was allowed to run 36 hours without rewinding, the violently swinging long periods first observed were apt to fall off to the short periods of but slight motion during the last twelve hours. Again, on starting the watch for the long period immediately after winding, if the swing is not quite wide enough, the short period eventually supervenes. This observation is suggestive: the rate at which energy is drained off by the resistances is in excess of the rate at which energy is imparted to the rocking watch. Like phases in the watch and the balance-wheel will not, in general, be at once established, and hence the connecting mechanism, as a rule, is ill adapted for effective transfer. Unless the long period is approached from a longer period (excessive swing of the pendulum), the former will thus be out of reach and the vibration will fall off to the short period.

Furthermore, if the period of the balance-wheel increases (as above) in the lapse of time, the corresponding long period will also increase. Hence the watch is now put in the same conditions observed when the watch is swung for the long period from too short an arc. The short period is eventually induced.

(6) The above observations as a whole offer an interesting

* An attempt to find the change of the period of these beats in the lapse of time failed.

illustration of Lord Rayleigh's theory of anomalous dispersion. In a system of two degrees of freedom the reaction effect of the forced vibration on the exciting vibration, is to shorten the period (increased rigidity) of the latter, if its proper period is the shorter, and to lengthen it if its proper period is longer than the proper period of the forced vibration. The reaction virtually increases or decreases the elastic forces of the medium respectively, in the two contrasted cases.

Now let the balance-wheel represent a vibrating æther particle, and the watch (pendulum) the vibrating absorption molecule, the proper period of the latter being greater than that of the former in the above experiments. If the balance-wheel starts the pendulum from rest, the compound period is shorter than either component period. Forces of restitution are increased for both. In other words the violet end, or the spectrum beginning at the absorption-band, has moved to the red end beyond the absorption-band, becoming at the same time more violet (periods generally decreased). Again, if the watch represents the æther particle and the wheel the vibrating absorption molecule, the watch with a wide swing starting the balance-wheel from rest, the compound period is greater than either component period. Elastic forces are both virtually diminished. In other words the red end, or the spectrum terminating in the absorption-band, has moved toward the violet end beyond the absorption-band and become more deeply red (periods generally increased). Had the watch been less imperfect it would be interesting to express this in detail, numerically.

The question occurs, why are not these relations completely reciprocal? To return to the first analogy, in which the balance-wheel (smaller proper period) represents the æther particle, and the watch the absorption molecule; if the latter in violent vibration were to excite the æther particle, the long period should appear. In other words, the spectrum on both sides of the absorption-band will move toward the red in colour, and toward the violet in regard to refraction. Both causes conspire to increase the index. Conversely, if by withdrawing ballast from the watch as above stated, its proper period were reduced below that of the balance-wheel, then, with the same terms of analogy, a compound period shorter than either would appear. This implies greater frequency and less refraction, or marked decrease of the index of refraction of the medium.

(7) The question may finally be asked with what accuracy an apparatus like the above rocking watch is adapted to

measure variations of the attraction of gravitation. Fig. 3 shows at once that the short period of the above watch would be unavailable for such a purpose, the changes of rate within the range of observation being too small. The conditions for the long period, however, are worth a statement. The effect of adding ballast is an increment both of the moment of inertia and of the torque acting on the compound pendulum. The following table contains the decrements of the acceleration of gravitation $\delta g/g$, corresponding to the increments of ballast for each of the series of experiments made.

TABLE III.—Equivalent decrements of Gravitation.

$\delta k/k$.	$\delta g/g$.	Rates, sec./hour, long period.
+000	-000	-39.8
013	-004	-39.7
023	-008	
030	-009	-46.0
046	-016	-58.3
091	-033	-75.3
240	-071	-135.0
380	-104	-199.3

These data show that the long period passes toward infinity at an accelerated rate with $\delta g/g$; for if the observations be grouped as suggested by the brackets, the successive increments of rate are 11 s./h., 16 s./h., and 19 s./h., respectively, for each per cent. of decrement of $\delta g/g$. If the mean value be taken, the loss of a second per day on the rocking watch is equivalent to a decrement of gravitational acceleration of $\delta g/g = .00003$. Even if one second per day is trustworthy on a good watch, this datum is about 200 times as large as the differential effect of a globe of lead 50 centim. in diameter, on the watch swinging immediately above and immediately below it.

The case is somewhat more favourable when the variations of acceleration met with in a gravitational survey are in question. Quoting from the interesting digest of a survey across North America due to Prof. Mendenhall,* it appears that the surface variations encountered lie within an interval of $13/10^4$, or 43 seconds per day on the above rocking watch; while the variations reduced to sea-level lie within $32/10^5$, about 11 seconds per day on the watch.

Brown University,
Providence, U.S.A.

* Mendenhall, American Journ. xlix. p. 81 (1895).

LIX. *On some Cases of Propagation of Electric Oscillations along a Number of Parallel Wires.* By W. B. MORTON; M.A., Professor of Natural Philosophy, Queen's College, Belfast*.

§ 1. *Introduction.*

WHEN simple harmonic electromagnetic waves are guided along conducting wires of finite resistance, the effect of the leads is to produce, first, a retardation of the speed of propagation as compared with that in free space, and, second, an attenuation of the amplitude of the waves as they proceed. Both these effects are, in general, functions of the frequency of the oscillations and of the constants of the conducting system. Their determination is what is mainly wanted in the solution of the problem. The complete solution, of course, involves in addition a knowledge of the distribution of the electric and magnetic vectors inside and outside the conductors.

Let λ be the wave-length, κ the attenuation-factor, $\frac{p}{2\pi}$ the frequency. Then, for waves travelling along the axis of z in the positive direction, the different vectors contain the factor

$$e^{-\kappa z} \sin \left(\frac{2\pi z}{\lambda} - pt \right).$$

Replacing this by

$$e^{i(mz - pt)}, \text{ where } m = \frac{2\pi}{\lambda} - i\kappa,$$

we see that a knowledge of the complex quantity m gives us at once the wave-length (and therefore the speed of propagation) and the attenuation factor. The case of a single wire surrounded by a sheath was worked out by Prof. J. J. Thomson†; that of a single wire isolated in space has been solved by Sommerfeld‡. In the latter case the return currents are carried by the dielectric; lines of force which start from a positive section of the surface of the wire bend round and end on an adjoining negative section, forming in general very long loops.

In experimental investigations on the subject the common arrangement consists of two similar parallel wires. For slow oscillations we have then Heaviside's well-known formula

$$m^2 = -(R + ipL)(S + ipC)$$

* Communicated, in abstract, to the British Association at Bradford

† J. J. Thomson, *Recent Researches*, p. 262.

‡ Sommerfeld, *Wied. Ann.* lxxvii. p. 233 (1899).

where $R L S C$ are respectively the resistance, inductance, leakage-conductance, and capacity, per unit-length of the leads. When the oscillations are not slow we may still employ this formula, but $R L S C$ will now be functions of p .

In the *Annalen der Physik* for June of the present year, G. Mie* has given a very complete solution of this problem of propagation along two similar parallel wires. He finds an expression for the wave-length and attenuation involving a series of ascending powers of the ratio of radius of wire to distance of the wires apart, which is usually a small quantity. He also determines completely the distribution of the electric and magnetic vectors.

§ 2. *Scope of the present Note.*

Before this paper appeared I had been working at the problem by a method of successive approximations. The bulk of this work has been rendered nugatory by the publication of Mie's much more satisfactory analysis, which gives a single formula from which the solution can be got to any desired degree of accuracy. The object of the present note is to point out how the *first approximation* to the complete solution may be very simply deduced from the known single-wire solution. This approximation, as Mie has shown, means that the *square* of the small quantity, radius of wire divided by distance apart, is neglected. The advantage of this way of arriving at the approximate solution lies in the fact that the method admits of application to more complicated cases where an exact solution is not possible. In fact we can obtain an approximate equation for m in the general case of any number of parallel wires of any sizes and materials, and any arrangement in space, provided that all the radii are small compared with all the relative distances. The different roots of this equation correspond to the different ways of grouping the wires into two opposite sets, such as might perhaps be realized by connecting them in different ways, each wire to a separate secondary plate in a Lecher arrangement. If we take corresponding points on the wires we shall have positive charges and currents on all the wires of one set, negative on those of the other set. We shall use "similar" and "opposite" to indicate wires belonging to the same or different groups.

§ 3. *List of Cases worked out.*

The equation in its general form is intractable. The following special cases are treated :—

* Mie, *Ann. d. Phys.* ii. p. 202 (1900).

- (1) Two wires of slightly different diameters, the wires being (a) opposite, as in the usual experimental arrangement, or (b) similar.
- (2) Three wires in an isosceles triangle, the base wires being opposite.
- (3) Four wires in rectangular arrangement, any grouping.
- (4) $2n$ wires in regular polygon, consecutive wires being opposite.
- (5) n wires in regular polygon, all the wires being similar.

§ 4. *Statement of Results for Single-wire case.*

We shall use the following quantities in addition to those already defined :—

$$k_1 = \frac{p}{V} = \frac{2\pi}{\lambda_0}, \quad \dots \dots \dots (1)$$

where V is the velocity of radiation, λ_0 the wave-length in free space.

$$k_2 = (1-i) \sqrt{\frac{2\mu\rho}{\rho}}, \quad \dots \dots \dots (2)$$

μ, ρ being the permeability and resistivity of the wire.

$$c^2 = k_1^2 - m^2 = \left(\frac{2\pi}{\lambda_0}\right)^2 - \left(\frac{2\pi}{\lambda} - i\kappa\right)^2 \dots \dots \dots (3)$$

c^2 is the function of the quantities λ, κ which will appear in the final equations.

Take now the case of the single isolated wire as worked out by Sommerfeld. We have three vectors to deal with, viz., lengthwise electric force, radial electric force, and magnetic force in circles concentric with the wire. The values of these which satisfy the differential equations, inside and outside the wire, are :—

	Inside.	Outside.	
Lengthwise electric force...	$dJ_0(k_2r)$	$DK_0(cr)$	}
Radial electric force.....	$d \cdot \frac{im}{k_2} J_1(k_2r)$	$D \frac{im}{c} K_1(cr)$	
Magnetic force	$d \cdot \frac{ik_2}{p} J_1(k_2r)$	$D \frac{ik_1}{pc} K_1(cr)$	

r is the distance from the axis of the wire. The J 's and K 's are the cylinder functions; d, D are constants. The magnitude m has been neglected in comparison with k_2 (*v. Thomson or Sommerfeld, loc. cit.*). Expressing that the tangential components are continuous we have, if a is the radius of the wire,

$$\frac{d}{D} = \frac{K_0(ca)}{J_0(k_2a)} = \frac{k_1^2 K_1(ca)}{k_2 c J_1(k_2a)} \dots \dots \dots (5)$$

∴ the equation for c is

$$\frac{cK_0(ca)}{K_1(ca)} = \frac{k_1^2 J_0(k_2 a)}{k_2 J_1(k_2 a)} \dots \dots \dots (6)$$

Now ca is always, as Sommerfeld has shown, a very small quantity (order 10^{-4} or 10^{-3}); K_0, K_1 therefore approximate to the values

$$\left. \begin{aligned} K_0 &= \log \frac{2i}{\gamma ca} \\ K_1 &= \frac{1}{ca} \end{aligned} \right\} \dots \dots \dots (7)$$

where γ is the constant 1.781 . . .

The equation then reduces to

$$c^2 \log \frac{2i}{\gamma ca} = \frac{k_1^2 J_0(k_2 a)}{k_2 a J_1(k_2 a)} = f, \text{ say.} \dots \dots (8)$$

If we write x for $\frac{-\gamma^2 c^2 a^2}{4}$ this assumes the form

$$x \log x = \text{constant} = y, \text{ say.} \dots \dots \dots (9)$$

Sommerfeld has shown how a numerical solution of this transcendental equation may be found by an ingenious method of successive approximations, and has worked out a number of typical cases. He has proved that we may write the result in the form $x = -\Theta y$, where Θ is a quantity which varies very slowly with y . Sommerfeld's typical examples cover the whole range of practically interesting cases, and for them Θ comes out a magnitude with a negligible imaginary part, and lying between $\frac{1}{20}$ and $\frac{1}{30}$. We shall have occasion to employ this approximate solution, using Θ to mean a real fraction of this order of magnitude. It is usual and convenient for purposes of discussion to distinguish two extreme cases, viz., those in which $k_2 a$, the argument of the J functions, is very large, and those in which it is very small. The former condition is secured by low resistance and permeability, high frequency and large radius; reversal of any of these circumstances tends to bring a case under the second head. It will be seen that large $(k_2 a)$ favours the development of the "skin effect." The corresponding values of the constant f are

$$\left. \begin{aligned} \text{large } (k_2 a) & \quad f = \frac{ik_1^2}{k_2 a} \\ \text{small } (k_2 a) & \quad f = \frac{2k_1^2}{k_2^2 a^2} \end{aligned} \right\} \dots \dots \dots (10)$$

§ 5. *Application to the Ordinary Two-wire Case.*

Let us now take the case of two similar parallel wires each of radius a , at a distance apart b which is large compared with a . Suppose we try, as a first attempt at a solution, to superpose two single-wire solutions of the type given in the last paragraph. The compounded vectors will, of course, satisfy the connecting equations for the dielectric. The difficulty arises when we come to the surface-conditions at the wires. But here we notice that of the three components specified in (4), there is one, the longitudinal electric force, which varies with $\log r$; the other two contain the factor $\frac{1}{r}$. The falling off in the values of the two $\left(\frac{1}{r}\right)$ components is much more rapid than for the $(\log r)$ component. Take for example $\frac{a}{b} = \frac{1}{100}$. The quantity $\log \frac{2i}{\gamma c a}$ is, in actual cases, roughly of order 10. At the surface of the second wire this is reduced by $\log_e 100 = 4.6$. So that at the second wire the longitudinal electric force due to the field of the first wire is about half as great as the force due to the field of the second wire itself; whereas the radial electric force and the magnetic force only amount to one per cent. of the corresponding values. In fact, to neglect at the surface of the second wire the radial electric force due to the first, involves the same degree of error as if we had the two wires statically charged with equal and opposite charges, and neglected the small variations from uniform distribution on the wires, due to their mutual influence.

If now we agree to retain at the surface of the second wire only the lengthwise component of the field of the first, and further, if we neglect the variation of this component from one point to another over the surface of the wire, we can arrange the ratio of the internal and external constants (d, D above) so as to satisfy the surface condition. We have then, instead of (4),

	Inside.	Outside.	
Lengthwise electric force...	$dJ_0(k_2 a)$	$D[K_0(ca) - K_0(cb)]$.	
Magnetic forces as before.			

$$\therefore \frac{d}{D} = \frac{K_0(ca) - K_0(cb)}{J_0(k_2 a)} = \frac{k_1^2 K_1(ca)}{k_2 c J_1(k_2 a)}. \quad (11)$$

The smallness of ca enables us to use the small argument value for $K_0(cb)$ also, in all cases except where $\frac{b}{a}$ is so great that the problem ceases to resemble experimental conditions.

The equation then reduces to

$$c^2 \log \frac{b}{a} = \frac{k_1^2 J_0(k_2 a)}{k_2 a J_1(k_2 a)} = f. \quad \dots \quad (12)$$

This agrees with Mie's result, neglecting $\frac{a^2}{b^2}$ and higher powers. It will be seen that a simple equation for c^2 replaces the transcendental form treated by Sommerfeld.

§ 6. *Equation for the most General Case.*

It is clear that we can apply the same method to the most general case, on the understanding that the mutual distances of the wires are all large in comparison with their radii. We shall have a different pair of constants (d, D) for each wire. The continuity of magnetic force for each wire will give

$$\frac{d}{D} = \frac{k_1^2 K_1(ca)}{k_2 c J_1(k_2 a)}, \quad \dots \quad (13)$$

the constants k_1, k_2, a having now different values for the different wires.

The lengthwise electric force inside the wire is as before,

$$\begin{aligned} dJ_0(k_2 a) &= D \frac{k_1^2 J_0(k_2 a)}{k_2 c J_1(k_2 a)} K_1(ca) \text{ by (13)} \\ &= D \frac{k_1^2 J_0(k_2 a)}{c^2 k_2 a J_1(k_2 a)} \\ &= D \frac{f}{c^2}. \end{aligned}$$

Distinguishing the wires by subscripts, we get for the first wire

$$D_1 \frac{f_1}{c^2} = D_1 K_0(ca_1) + D_2 K_0(cb_{12}) + D_3 K_0(cb_{13}) + \dots \quad (14)$$

$b_{12}, b_{13},$ &c. being the mutual distances.

For shortness write

$$\left. \begin{aligned} K_0(ca_1) &= \log \frac{2i}{\gamma ca_1} = A_1 \\ K_0(cb_{12}) &= B_{12}, \text{ and so on.} \end{aligned} \right\} \dots \quad (15)$$

The equation giving c for the system is

$$\left| \begin{array}{ccc} A_1 - \frac{f_1}{c^2} & B_{12} & B_{13} \dots \\ B_{12} & A_2 - \frac{f_2}{c^2} & B_{23} \dots \\ \dots & \dots & \dots \end{array} \right| = 0. \quad \dots \quad (16)$$

§ 7. Case of Two nearly equal Wires.

Let $a_1 = a$, $a_2 = a(1 + \epsilon)$, where ϵ is a small fraction whose square may be neglected; then

$$\begin{aligned} \log a_2 &= \log a + \epsilon, \\ A_2 &= A_1 - \epsilon. \end{aligned}$$

Taking the case where $k_2 a$ is large, $f_2 = f_1(1 - \epsilon)$.

The general equation becomes for this case

$$\left(A - \frac{f}{c^2}\right) \left[A - \epsilon - \frac{f}{c^2}(1 - \epsilon)\right] = B^2. \quad \dots \quad (17)$$

Regarding this as a quadratic in $\frac{f}{c^2}$ and solving, we get

$$\frac{f}{c^2} = A + \frac{1}{2}\epsilon(A - 1) \pm B(1 + \frac{1}{2}\epsilon). \quad \dots \quad (18)$$

(a) The lower sign gives the result for two *opposite* wires

$$\begin{aligned} \frac{f}{c^2} &= (A - B)\left(1 + \frac{1}{2}\epsilon\right) - \frac{1}{2}\epsilon \\ &= \log \frac{b}{a} + \frac{1}{2}\epsilon \left(\log \frac{b}{a} - 1\right). \quad \dots \quad (19) \end{aligned}$$

It is of interest to compare the magnitudes of the currents in the two wires. The magnetic force just outside the wire

is $D \frac{ik_1^2}{pc^2 a}$, the total current across the section is therefore equal to $D \frac{ik_1^2}{2pc^2}$, and the currents at corresponding points of

the two wires are in the ratio $D_1 : D_2$. It is easy to prove that the ratio of the surface-charges has the same value. Referring to equation (14) we find

$$\begin{aligned} -\frac{D_2}{D_1} &= \frac{A - \frac{f}{c^2}}{B} = \frac{B - \frac{1}{2}\epsilon(A - B - 1)}{B} \\ &= 1 - \frac{1}{2}\epsilon \frac{\left(\log \frac{b}{a} - 1\right)}{\log \frac{2i}{\gamma cb}}. \quad \dots \quad (20) \end{aligned}$$

Examination shows that the small quantity has a positive real part, therefore the modulus of D_2 is smaller than that of D_1 , or the *larger* wire carries *less* current and surface-charge than the other.

Looking at the matter from a more physical standpoint, we

see that, while the greater number of lines of force, starting from a positive section of one wire, find their way to the surface of the other wire, there will be also, close to the points of zero surface-charge, some *re-entrant* lines, with their ends on adjoining sections of the same wire. Our analysis shows that the proportion of these latter lines is greater for the smaller wire. It will help us to understand this result if we consider that when the wires are isolated, as in Sommerfeld's case, the *scale* is smaller when the radius of the wire is smaller. The loops formed by the lines of force, now all re-entrant, are shorter; and so, when a second wire is brought up, the proportion of these looped lines which lie close enough to the wire to preserve their arrangement undisturbed, is greater.

I have worked out, numerically, the case of two copper wires of the dimensions and conductivity taken by Sommerfeld in his first case, and found the effect of making the radius of one wire 1 per cent. greater than the other, their distance apart being 100, 200, and 300 times the radius. The numerical data are:—

$$a = 0.2 \text{ cm.}, \quad \frac{\rho}{2\pi} = 10^9, \quad \frac{1}{\rho} = 5.83 \times 10^{-4}, \quad \epsilon = \frac{1}{100}.$$

The ratio $\frac{-D_2}{D_1}$ comes out:—

$$\begin{aligned} \text{for } \frac{b}{a} = 100, & \quad \frac{99.5 + .07i}{100}; \\ \frac{b}{a} = 200, & \quad \frac{99.3 + .11i}{100}; \\ \frac{b}{a} = 300, & \quad \frac{99.2 + 1.58i}{100}. \end{aligned}$$

So that the differences amount roughly to 5, 7, and 8 parts in a thousand. The imaginary part indicates a small phase-difference between corresponding points on the wires, the larger wire being in advance.

(b) When the two wires are similar we have, taking the positive sign in equation (18),

$$\begin{aligned} \frac{f}{c^2\epsilon} &= A + B + \frac{1}{2}\epsilon(A + B - 1) \\ &= \log\left(\frac{-4}{\gamma^2 c^2 ab}\right) + \frac{1}{2}\epsilon\left[\log\left(\frac{-4}{\gamma^2 c^2 ab}\right) - 1\right]. \dots \quad (21) \end{aligned}$$

A similar investigation shows that in this case the larger wire carries more current than the other. We obtain results of the same character when we suppose $k_2 a$ small.

§ 8. *Three Wires in Isosceles Triangle.*

Use 1 for the vertex wire, 2, 3 for the base wires. Let the base wires have the same radius and material, then $B_{12} = B_{13}$, $A_2 = A_3$, $f_2 = f_3$. The determinant equation becomes

$$\begin{vmatrix} A_1 - \frac{f_1}{c^2} & B_{12} & B_{12} \\ B_{12} & A_2 - \frac{f_2}{c^2} & B_{23} \\ B_{12} & B_{23} & A_2 - \frac{f_2}{c^2} \end{vmatrix} = 0. \quad (22)$$

Subtracting the third column from the second we see that $A_2 - B_{23} - \frac{f_2}{c^2}$ is a factor. Using this root of the equation,

$$\frac{f_2}{c^2} = A_2 - B_{23} = \log \frac{b}{a}, \quad (23)$$

where b is the length of the base. Putting in the value for $\frac{f_2}{c^2}$ in the equations, we get at once

$$D_1 = 0, \quad D_2 = -D_3. \quad (24)$$

Therefore we have got the case in which the base wires are carrying equal and opposite currents, and the vertex wire is quite free from current. The equation for c^2 is the same as if there were no third wire. The remaining two roots of the cubic in c^2 correspond to the cases where the base wires are similar, and either opposite or similar to the vertex wire. The equation for these arrangements is intractable.

We infer from the above that when two wires are conveying electric oscillations, a third wire equidistant from them plays a passive part. It follows at once that if we have two pairs of wires at the corners of a *rhombus* there will be no mutual influence between the pairs. For example, telephonemessages sent along the pair at the ends of one diagonal of the rhombus will not be overheard along the other pair.

When the triangle is *equilateral* we can have currents, whose algebraic sum is zero, divided among the wires in any manner.

§ 9. *Four Wires in Rectangular Arrangement.*

In this case we can split up the determinant into four factors corresponding to the four ways of grouping the wires.

We may indicate these arrangements by the notation (1234), (12) (34), (13) (24), (14) (23), numbers enclosed in one bracket indicating similar wires which are opposite to the wires in the other bracket. The wires in this and the remaining cases are identical in size and material. All the A's and f's are equal, and $B_{12} = B_{34}$, $B_{13} = B_{24}$, $B_{14} = B_{23}$. The determinant is

$$\begin{vmatrix} A - \frac{f}{c^2}, & B_{12}, & B_{13}, & B_{14}, \\ B_{12}, & A - \frac{f}{c^2}, & B_{14}, & B_{13}, \\ B_{13}, & B_{14}, & A - \frac{f}{c^2}, & B_{12}, \\ B_{14}, & B_{13}, & B_{12}, & A - \frac{f}{c^2}, \end{vmatrix} \dots \dots \dots (25)$$

$$= \left(A - \frac{f}{c^2} + B_{12} + B_{13} + B_{14} \right) \left(A - \frac{f}{c^2} + B_{12} - B_{13} - B_{14} \right)$$

$$\times \left(A - \frac{f}{c^2} - B_{12} + B_{13} - B_{14} \right) \left(A - \frac{f}{c^2} - B_{12} - B_{13} + B_{14} \right).$$

Taking the factors in turn, and finding the corresponding ratios for the D's, we find :—

- $D_1 = D_2 = D_3 = D_4$ grouping (1234),
- $D_1 = D_2 = -D_3 = -D_4$ „ (12) (34)
- $D_1 = -D_2 = D_3 = -D_4$ „ (13) (24),
- $D_1 = -D_2 = -D_3 = D_4$ „ (14) (23).

For the first case, where the wires are similar, we get an equation which can be reduced to Sommerfeld's $x \log x$ type, viz.:—

$$\frac{f}{c^2} = \log \frac{16}{\gamma^4 a b_{12} b_{13} b_{14} c^4} \dots \dots \dots (26)$$

The other cases give simple equations of the two-wire type, e. g. for (12) (34):—

$$\frac{f}{c^2} = \log \frac{b_{13} b_{14}}{a b_{12}} \dots \dots \dots (27)$$

Thus when the oscillations are propagated along four wires in rectangular arrangement, two wires serving as returns to the other two, the speed and the attenuation are the same as if we had two wires at distance $\frac{b_{13} b_{14}}{b_{12}}$; i. e., the rectangle between

the two distances of opposite wires divided by the distance of the similar wires.

§ 10. $2n$ Wires at corners of Regular Polygon, consecutive wires being opposite.

It is clear from symmetry that $D_1 = -D_2 = D_3 = -D_4 = \dots$; therefore equation (14) gives at once

$$\begin{aligned} \frac{f}{c^2} &= A - B_{12} + B_{13} - \dots - B_{1(2n-2)} + B_{1(2n-1)} - B_{12n} \\ &= \log \frac{b_{12} b_{14} \dots b_{1, 2n}}{a b_{13} b_{15} \dots b_{1, (2n-1)}} \dots \dots \dots (28) \end{aligned}$$

Let r be the radius of the circumscribing circle, then

$$b_{12} = 2r \sin \frac{\pi}{2n}, \quad b_{13} = 2r \sin \frac{2\pi}{2n}, \quad \&c.;$$

$$\begin{aligned} \therefore \frac{f}{c^2} &= \log \frac{2r}{a} + \log \frac{\sin \frac{\pi}{2n} \sin \frac{3\pi}{2n} \dots \sin \frac{(2n-1)\pi}{2n}}{\sin \frac{2\pi}{2n} \sin \frac{4\pi}{2n} \dots \sin \frac{(2n-2)\pi}{2n}} \\ &= \log \frac{2r}{a} + \log \frac{1}{n} \\ &= \log \frac{2r}{na} \dots \dots \dots (29) \end{aligned}$$

Therefore the speed and attenuation with the given arrangement are the same as for a pair of leads at distance $\frac{2r}{n}$.

§ 11. n Wires at corners of Regular Polygon, all carrying similar currents.

Here $D_1 = D_2 = D_3, \dots$, and we have

$$\begin{aligned} \frac{f}{c^2} &= A + B_{12} + B_{13} + \dots + B_{1n} \\ &= n \log \frac{2i}{\gamma c} - \log a - (n-1) \log 2r - \log \sin \frac{\pi}{n} \sin \frac{2\pi}{n} \dots \sin \frac{(n-1)\pi}{n} \quad (30) \end{aligned}$$

Write g for $\sin \frac{\pi}{n} \sin \frac{2\pi}{n} \dots \sin \frac{(n-1)\pi}{n}$,

$$\begin{aligned} \frac{f}{c^2} &= -\log \left(\frac{\gamma^n c^n r^{n-1} g}{2i^n} \right) \\ &= -\frac{n}{2} \log \left(-\frac{\gamma^2 r^{\frac{2(n-1)}{n}} g^n}{2^{\frac{2}{n}}} c^2 \right) \dots \dots \dots (31) \end{aligned}$$

We may write this

$$-c^2 \log(-hc^2) = \frac{2f}{n}$$

(h being the constant inside the bracket);

$$\therefore -hc^2 \log(-hc^2) = \frac{2hf}{n}.$$

Therefore, using Sommerfeld's approximate solution as stated in § 4 above,

$$\begin{aligned} -hc^2 &= -\frac{2hf}{n} \Theta, \\ c^2 &= \Theta \frac{2f}{n} \dots \dots \dots (32) \end{aligned}$$

So that, if we neglect the slow variation of Θ , the solution is independent of h .

To find a measure of the effect of the n leads under discussion, we may compare them with a single wire of the same material. For this we have by (8), a' being the radius, and f' the corresponding constant,

$$\begin{aligned} -c^2 \log\left(-\frac{\gamma^2 a'^2}{4} c^2\right) &= 2f' \\ c^2 &= \Theta \cdot 2f' \dots \dots \dots (33) \end{aligned}$$

Therefore if the single wire is to produce the same effect as the n wires, we must have

$$nf' = f.$$

Referring to (10), we see that when $k_2 a$ is large this gives

$$a' = na;$$

when $k_2 a$ is small,

$$a'^2 = na^2.$$

In other words, when the skin-effect is marked the n wires produce the same effect on the waves as a single wire of n times the *perimeter*; but when the currents are not concentrated on the surface, but occupy the whole section, the n wires can be replaced by a single wire of n times the *area*. This result was of course to be expected from general considerations. The same approximate method of treatment might be applied to equation (26) above.

Queen's College, Belfast.
19th October, 1900.

LX. *Notices respecting New Books.*

The Scientific Papers of JOHN COUCH ADAMS, M.A., Sc.D., D.C.L., LL.D., F.R.S., late Lowndean Professor of Astronomy and Geometry in the University of Cambridge. Vol. II. (Cambridge: at the University Press, 1900.)

THE former volume of Prof. Adams's Scientific Papers was issued in 1896, and noticed in our vol. xliii. p. 71. It comprised all those which were published by that distinguished astronomer during his lifetime, from 1844, when he was 23 years of age, to 1890, which was two years before his death. But besides these, a large number of papers (as was remarked in our notice) on different branches of astronomy were left in an incomplete state amongst his manuscripts. These have been prepared for publication by Prof. Sampson, of the University of Durham, and form, together with abstracts of a number of lectures, the first part of the volume now before us. The Preface describes the labour involved in the preparation of the manuscripts for press. They consisted of an accumulation of notes, studies, and rough work; and though, to use Prof. Sampson's words, "very few probably have written their studies in a form so finished as Adams," and though his manner of treating subjects of which he had the absolute mastery seemed "to symbolize as well as to calculate the motions of the stars," yet it was impossible to reproduce his own words and order, and was necessary in fact to re-write the papers. The most important are on numerical developments in the lunar theory, the secular acceleration of the moon's mean motion, the theory of Jupiter's satellites, the perturbation of the orbit of the November meteors, and the figure of the earth. With regard to the lectures, the editor followed the guidance of notes taken by Mr. A. Graham of the Cambridge Observatory, by the late Rev. A. Freeman (who at one time acted as deputy to Prof. Challis, Airy's successor in the Plumian chair), and by himself. The first indeed, as here given, is substantially from Prof. Sampson's own notes: it contains an historical sketch of the lunar theory, which commenced with Newton. The others are on various points in that theory, the original aim being to illustrate geometrically the analytical processes, and thereby render them more comprehensible; but others being added and several re-written, so that the whole fabric was gradually changed into the form in which it is here presented.

The Second Part of the present volume is on the theory of terrestrial magnetism, and is edited (like the first volume) by the author's brother, Prof. W. Grylls Adams, of King's College, London. The work of the determination of the Gaussian magnetic constants was first taken in hand fifty years ago, not long after the discovery of the planet Neptune, and was suggested by Gauss's paper, a translation of which was published in Taylor's 'Scientific Memoirs' in 1841; Gauss's own work having been founded on the publication of Sabine's map of the total intensity

in the seventh Report of the British Association (*i. e.* that for 1837). The need spoken of by Gauss for accurate determinations of the magnetic declination, horizontal intensity, and dip, taken at stations uniformly distributed as in a network over the surface of the earth, is even now very imperfectly supplied, particularly in the southern hemisphere; still much has been done in the last fifty years, and we were glad lately to notice that observations of that kind are being carried on by Dr. Doberck at Hongkong. Prof. J. C. Adams's work here set forth forms an important and valuable contribution to the progress of knowledge in this department; and the tables contained in it, after being most carefully calculated by the assistants at the observatory, have also been verified by some of those on the staff of the 'Nautical Almanac.' Altogether these two volumes will form an enduring monument to the memory of one scarcely known to the general public except as a discoverer of Neptune by the great achievement of calculating its path before it was actually seen; in which he had the priority.

LXI. *Intelligence and Miscellaneous Articles.*

NEW RESEARCHES INTO POUILLET'S PHENOMENON (THE HEAT DEVELOPED IN WETTING POWDERS). BY TITO MARTINI.

IN this third memoir, published in the 'Proceedings of the Royal Institute of Venice',* I have demonstrated, by means of numerous experiments, that there are powders (thermometer-glass, quartz, calcium carbonate, &c.) which moisten well with water or other liquids, but which heat little or not at all however finely reduced. Other powders, like silica, the silicates, vegetable earth, artificial coals, undergo a great rise in temperature whether bathed in water, alcohol, ether, &c.

With silica and animal charcoal I made new calorimetric measures, and obtained values larger than those recorded in my previous paper†, because I was careful to dry the powder well. The new values which represent the heat yielded to the calorimeter vary from 17 to 18.50 calories about, according to the degree of dryness of the powder.

It is my opinion that a degree of heat so considerable is produced by the modification that the liquid undergoes when absorbed by the powder, by means of which modification the liquid is reduced to a condition of lower molecular energy. As a matter of fact, putting a determined weight of powder into a constant calorimetric mass, I have been able to observe a diminution in the mass of the calorimeter, because the specific heat of a part of the water absorbed becomes equal to that of the ice. The demonstration of this interesting result is founded upon the following experiment.

* *Atti del Reale Istituto Veneto*, T. lxx. parte seconda, p. 615.

† *Philosophical Magazine*, March 1899, p. 329.

Let P be a weight of powder, silica or animal charcoal, not dry but taken in its natural condition. Pouring this powder into the calorimeter, Q calories are developed. Then let us dry an equal weight of powder taken from the same source; there will be found a diminution of weight p , due to the water expelled. If we multiply the weight p by the heat of fusion of ice, we shall obtain a number of calories Q' , which, added to the number Q , make a sum equal to the number of calories that would be obtained by pouring into the calorimeter a weight P of powder completely, or almost, dry.

A few experimental data, referred to 1 gram of silica and to 1 gram of animal charcoal, are given below :--

Calories developed from 1 gr. of Powder not dried.	Weight of the Water expelled from 1 gr. of Powder.	Value of $80 \times p$.	Value of $Q + Q'$.	
Silica ... {	6.52	0.1383	11.06	17.58
	6.33	0.1414	11.31	17.64
	6.38	0.1487	11.90	18.28
Animal Charcoal } 5.16	0.1630	13.04	18.20	

The figures of the fourth column coincide, with great approximation, with those found directly with dry powders, as results from the following data recorded in my new memoir :--

Calories developed from 1 gr. of well-dried Silica.	Calories developed from 1 gr. of well-dried Animal Charcoal.
17.66	18.17
17.82	18.45
18.40	18.82

These experiments are a contribution to the new theory of solid solutions.

Venice, July 1900.



INDEX TO VOL. L.

- AETHER**, on the motion of ponderable matter through space occupied by, 181; on the duties of, for electricity and magnetism, 305.
- Allen (H. S.) on the motion of a sphere in a viscous fluid, 323, 519.
- Alloys, on the heat of formation of, 37, 231.
- , of iron, on the effects of temperature on the magnetic properties of, 1.
- Alps, on torsion-structure in the, 261.
- Annual march of temperature, on the, 408.
- Aqueous vapour, on the spectra of hydrogen and the spectrum of, 338.
- Arc spectra of some metals as influenced by an atmosphere of hydrogen, on the, 497.
- Atmosphere, on the chemical and geological history of the, 312, 399.
- Azobenzol, on the velocity of solidification of, 249.
- Barnard (R. J. A.) on the annual march of temperature, 408.
- Barton (Dr. E. H.) on the reflexion and transmission by condensers of electric waves along wires, 357.
- Barus (Prof. C.) on the rates of a rocking watch, 595.
- Beattie (R.) on the spark-length of an induction-coil, 139; on a possible source of error in the use of a ballistic galvanometer, 575.
- Bellamy (C. V.) on the salt-lake of Larnaca, 356.
- Benzoic anhydride, on the velocity of solidification of, 246.
- Benzophenone, on the velocity of solidification of, 248.
- Bickerton (Prof. A. W.) on cosmic evolution, 216.
- Books, new:—Boyer's *Histoire des Mathématiques*, 176; Wiedemann and Ebert's *Physikalisches Praktikum*, 177; Meyer's *The Kinetic Theory of Gases*, 177; Ostwald's *Grundriss der Allgemeinen Chemie*, 534; *The Scientific Papers of John Couch Adams*, 617.
- Buchanan (J.) on torsion-structure in the Alps, 261.
- Burbury (S. H.) on the law of partition of energy, 584.
- Cailletet and Mathias, on the law of, 291.
- Callaway (Dr. C.) on Longmyndian inliers in Gloucestershire, 352.
- Chappius (Dr. P.) on gas-thermometry, 433.
- Charge, on loss of, by evaporation, 489.
- Coherer, on the action of the, 445.
- Condensers, on the reflexion and transmission by, of electric waves along wires, 357.
- Constant-volume gas-thermometer, on the, 251.
- Copper-zinc alloys, on the action of, on nitric acid, 231.
- Cosmic evolution, on, 216.
- Crew (Prof. H.) on the arc spectra of some metals as influenced by an atmosphere of hydrogen, 497.
- Current, on the production of x -rays by a battery, 132.

- Davison (Dr. C.) on scales of seismic intensity, 44; on the sea-waves connected with the Japanese earthquake of June 15, 1896, 579.
- Density, on the law of Cailletet and Mathias and the critical, 291.
- Deviations from the probable, on the criterion that a given system of, is such that it can be supposed to have arisen from random sampling, 157.
- Diaphragm movements, on a micrometer for measuring, 537.
- Dielectric, on the supposed elongation of a, in an electrostatic field, 198.
- Dispersion, illustration of the theory of anomalous, 603.
- Earthquake, on the sea-waves connected with a Japanese, 579.
- Earthquakes, on scales of the intensity of, 44.
- Elastic constants of rocks, on the, 53.
- solid, on the motion of ponderable bodies through infinite space occupied by an, 181.
- Elasticity of wires, on the, 416.
- Electric micrometer, on an, 537.
- oscillations, on the propagation of, along parallel wires, 605.
- waves, on the reflexion and transmission by condensers of, along wires, 357.
- Electricity, on the genesis of the ions in the discharge of, through gases, 278; on the duties of æther for, 305.
- Electrolytes, on a diagram of freezing-point depressions for, 505.
- Electrons, on the theory of, 269.
- Electrostatic field, on the supposed elongation of a dielectric in an, 198.
- Energy, on the law of partition of, 584.
- Evans (Dr. J. W.) on mechanically-formed limestones from Junagarh, 536.
- Evaporation, on loss of charge by, 489.
- Extensometer, on a new, 87.
- Faraday dark space of vacuum-tubes, on the potential gradient in the, 503.
- Fluid, on the motion of a sphere in a viscous, 323, 519.
- Freezing-point depressions for electrolytes, on a diagram of, 505.
- Frequency-curves, on the determination of goodness of fit in, 157.
- distributions, on the tabulation of certain, 393.
- Galvanometer, on a possible source of error in the use of a ballistic, 575.
- Gas-thermometer, on the constant-volume, 251.
- Gas-thermometry, notes on, 433.
- Gases, on the genesis of the ions in the discharge of electricity through, 278.
- Geological Society, proceedings of the, 179, 265, 352, 443, 536.
- Gladstone (Dr. J. H.) on the action of copper-zinc alloys on nitric acid, 231.
- Glazebrook (R. T.) on the measurement of some standard resistances, 410.
- Guest (J. J.) on the strength of ductile materials under combined stress, 69.
- Gwyther (R. F.) on progressive long waves, 213, 308; on the general motion of long waves, 349.
- Harmer (F. W.) on the Pliocene deposits of the East of England, 353.
- Heat of formation of alloys, on the, 37, 231; on the, developed in wetting powders, 618.
- Henderson (W. C.) on the loss of charge of an electrified liquid by evaporation, 489.
- Hill (J. B.) on a new type of rock from Kentallen, 444.
- Hydrogen, on the spectra of, and the spectrum of aqueous vapour, 338; on the arc spectra of some metals as influenced by an atmosphere of, 497.
- Induction-coil, on the spark-length of an, 139.
- Ionization, on the relation of the depression of the freezing-point to the state of, 505.
- Ions, on the genesis of the, in the discharge of electricity through gases, 278.

- Iron, on the effects of temperature on the magnetic properties of, 1; on the effects of twist on the thermo-electric qualities of, 223; on the arc spectrum of, 503.
- Kelvin (Lord) on the motion produced in an infinite elastic solid by the motion through the space occupied by it of a body acting on it only by attraction or repulsion, 181; on the duties of ether for electricity and magnetism, 305.
- Kynaston (H.) on a new type of rock from Kentallen, 444.
- Larmor (Dr. J.) on the theory of electrons, 277.
- Liquids, on the velocity of solidification and viscosity of supercooled, 238; on the loss of charge of electrified, by evaporation, 489.
- Lomas (J.) on the inorganic constituents of the crag of Essex, 356.
- Lownds (L.) on the reflexion and transmission by condensers of electric waves along wires, 357.
- MacGregor (Prof. J. G.) on a diagram of freezing-point depressions for electrolytes, 505.
- Magnesium, on the arc spectrum of, 500.
- Magnetic properties of iron, on the effects of temperature on the, 1.
- Magnetism, on the duties of æther for, 305.
- Martini (Prof. T.) on the heat developed in wetting powders, 618.
- Materials, on the strength of ductile, under combined stress, 69.
- Mayer's hypothesis, on the methods of testing, 259.
- Metals, on the arc spectra of some, as influenced by an atmosphere of hydrogen, 497.
- Micrometer, on an electric, 537.
- Microscope, on the illumination of objects under the, 347.
- Minerals containing rare elements, on the discovery and occurrence of, 268.
- Mizuno (T.) on the action of the coherer, 445.
- Molecular constitution of water, on the, 460.
- More (Dr. L. T.) on the supposed elongation of a dielectric in an electrostatic field, 198.
- Morton (Prof. W. B.) on the propagation of electric oscillations along parallel wires, 605.
- Nagaoka (Prof. H.) on the elastic constants of rocks and the velocity of seismic waves, 53.
- Nitric acid, on the action of copper-zinc alloys on, 221.
- Nitrogen thermometer, corrections to the, 433.
- Nordenskiöld (Baron A. E.) on the discovery and occurrence of minerals containing rare elements, 268.
- Orr (Prof. W. McF.) on the theory of electrons, 269.
- Oscillations, on the propagation of electric, along parallel wires, 605.
- Oxygen, on the history of free, 312, 399; on the presence of, in the sun, 343.
- Parkinson (J.) on the rocks of Jersey, 179, 180.
- Pearson (Prof. K.) on the criterion that a given system of deviations from the probable in a correlated system of variables is such that it can be supposed to have arisen from random sampling, 157.
- Pendulum, remarks on a gravitational, 595.
- Platinum thermometers, on the comparison of, 421.
- Pouillet's phenomenon, on, 618.
- Powders, on the heat developed in wetting, 618.
- Pressure-gauge, on a new type of, 86.
- Probability, on a criterion of, 157.
- Rayleigh (Lord) on approximately simple waves, 135; on a theorem analogous to the virial theorem, 210.
- Reed (F. R. C.) on the igneous rocks of the coast of Waterford, 443.
- Resistances, on the measurement of some standard, 410.
- Rocks, on the elastic constants of, 53.
- Rose-Innes (J.) on the constant-volume gas-thermometer, 251.

- Rutley (F.) on eruptive rocks from New Zealand, 267.
- Salol, on the velocity of solidification of supercooled, 238.
- Sea-waves connected with a Japanese earthquake, on, 579.
- Seismic intensity, on scales of, 44.
- waves, on the velocity of, 53
- Shaw (P. E.) on lecture experiments illustrating syntony, 283; on an electric micrometer, 537.
- Sheppard (W. F.) on the tabulation of certain frequency-distributions, 393.
- Skinner (Dr. C. A.) on the potential gradient in the Faraday dark space of vacuum-tubes, 563.
- Solidification of supercooled liquids, on the velocity of, 238.
- Spark-length of an induction-coil, on the, 139.
- Spectra of hydrogen and the spectrum of aqueous vapour, on the, 338; on the arc, of some metals as influenced by an atmosphere of hydrogen, 497.
- Sphere, on the motion of a, in a viscous fluid, 323, 519.
- Stevenson (J.) on the chemical and geological history of the atmosphere, 312, 399.
- Strength of ductile materials under combined stress, on the, 69.
- Stress, on the strength of ductile materials under combined, 69.
- Striæ, on an application of the method of, to the illumination of objects under the microscope, 347.
- Sulphur-point, determination of the, 435.
- Sun, on the presence of oxygen in the, 343.
- Sutherland (W.) on the molecular constitution of water, 460.
- Syntony, on lecture experiments illustrating, 283.
- Taylor (J. B.) on the heat of formation of alloys, 37.
- Temperature, on the effects of, on the magnetic properties of iron, 1; on the annual march of, 408.
- Thermo-electric qualities of iron, on the effects of twist on the, 223.
- Thermometer, on the constant-volume gas-, 251.
- Thermometers, on the comparison of platinum, 421.
- Thermometry, notes on gas-, 433.
- Thomson (Prof. J. J.) on the genesis of the ions in the discharge of electricity through gases, 278.
- Torsion-structure in the Alps, on, 261.
- Tory (H. M.) on the comparison of platinum thermometers, 421.
- Trowbridge (Prof. J.) on the production of the *x*-rays by a battery current, 132; on the spectra of hydrogen and the spectrum of aqueous vapour, 338.
- Tsuruta (K.) on the effects of twist on the thermo-electric qualities of iron, 223.
- Twist, on the effects of, on the thermo-electric qualities of iron, 223.
- Vacuum-tubes, on the potential gradient in the dark space of, 563.
- Virial theorem, on a theorem analogous to the, 210.
- Viscosity, on the velocity of solidification and, of supercooled liquids, 238.
- Watch, on the rates of a rocking, 595.
- Water, on the absolute value of the freezing-point of, 253; on the molecular constitution of, 460.
- Wave-fronts, on the evolutions of reflected, 148.
- Waves, on the velocity of seismic, 53; on approximately simple, 135; on the photography of sound-, 148; on progressive long, 213, 308; on the general motion of long, 349; on the reflexion and transmission by condensers of electric, along wires, 357.
- Wills (R. L.) on the effects of temperature on the magnetic properties of iron and alloys of iron, 1.
- Wilson (Dr. H. A.) on the velocity of solidification and viscosity of supercooled liquids, 238.
- Wimperis (H. E.) on the elasticity of wires, 416.
- Wires, on the reflexion and transmission by condensers of electric waves along, 357; on the elasticity of, 416; on the propagation of electric oscillations along parallel, (05).

- Wood (Miss E. M. R.) on the Lower Ludlow formation, 265.
- Wood (Prof. R. W.) on the photography of sound-waves, and the kinematographic demonstration of the evolutions of reflected wave-fronts, 148; on an application of the method of striæ to the illumination of objects under the microscope, 347.
- x*-rays, on the production of, by a battery current, 132.
- Yield-point, on the, as the criterion of strength, 73.
- Young (Prof. S.) on the law of Cailletet and Mathias and the critical density, 291.
- Zinc, on the arc spectrum of, 502.
- Zinc-copper alloys, on the action of, on nitric acid, 231.

END OF THE FIFTIETH VOLUME.

AN FRANCIS

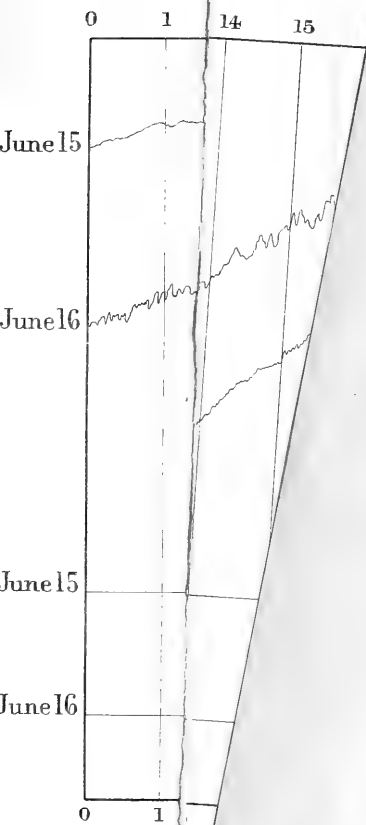



RECORD OF TIDE-GAUGE AT SAUSALITO (SAN FRANCISCO BAY).

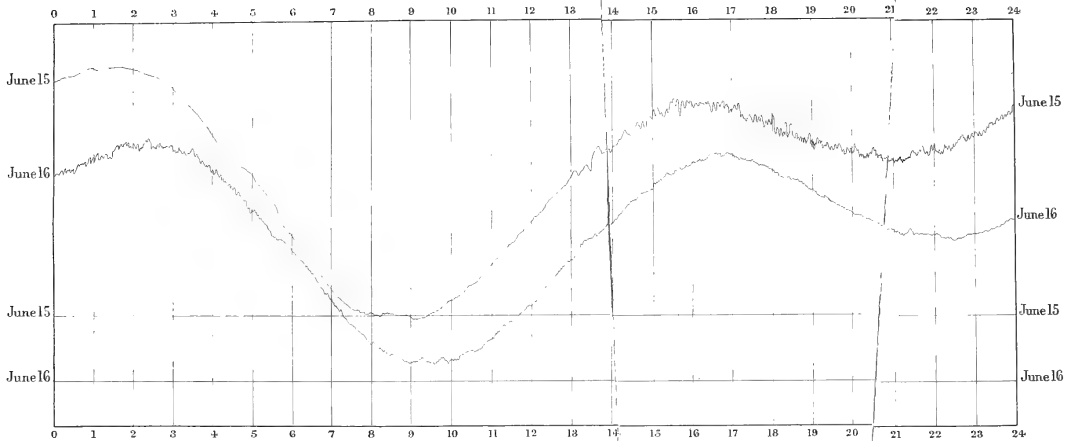



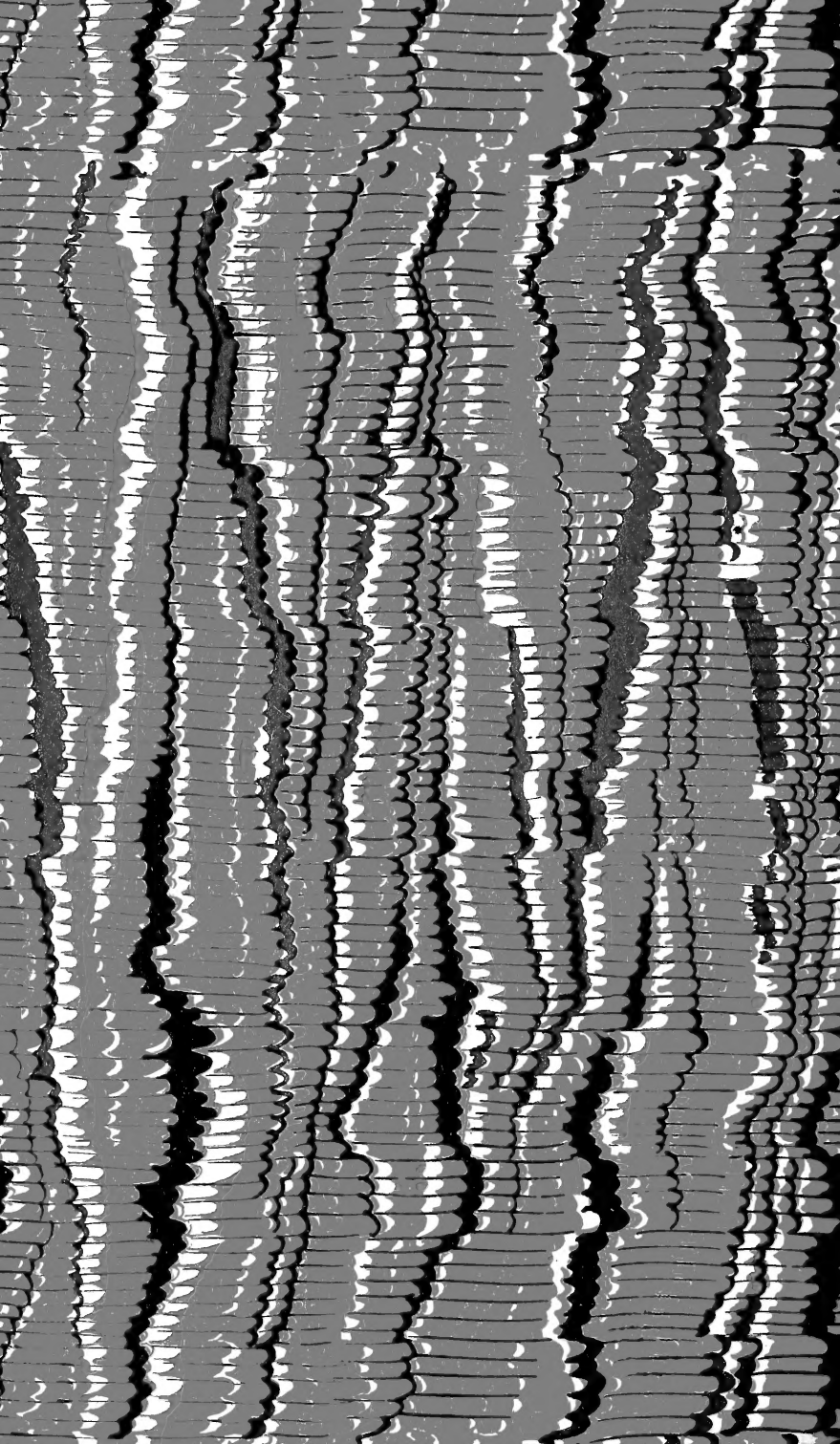

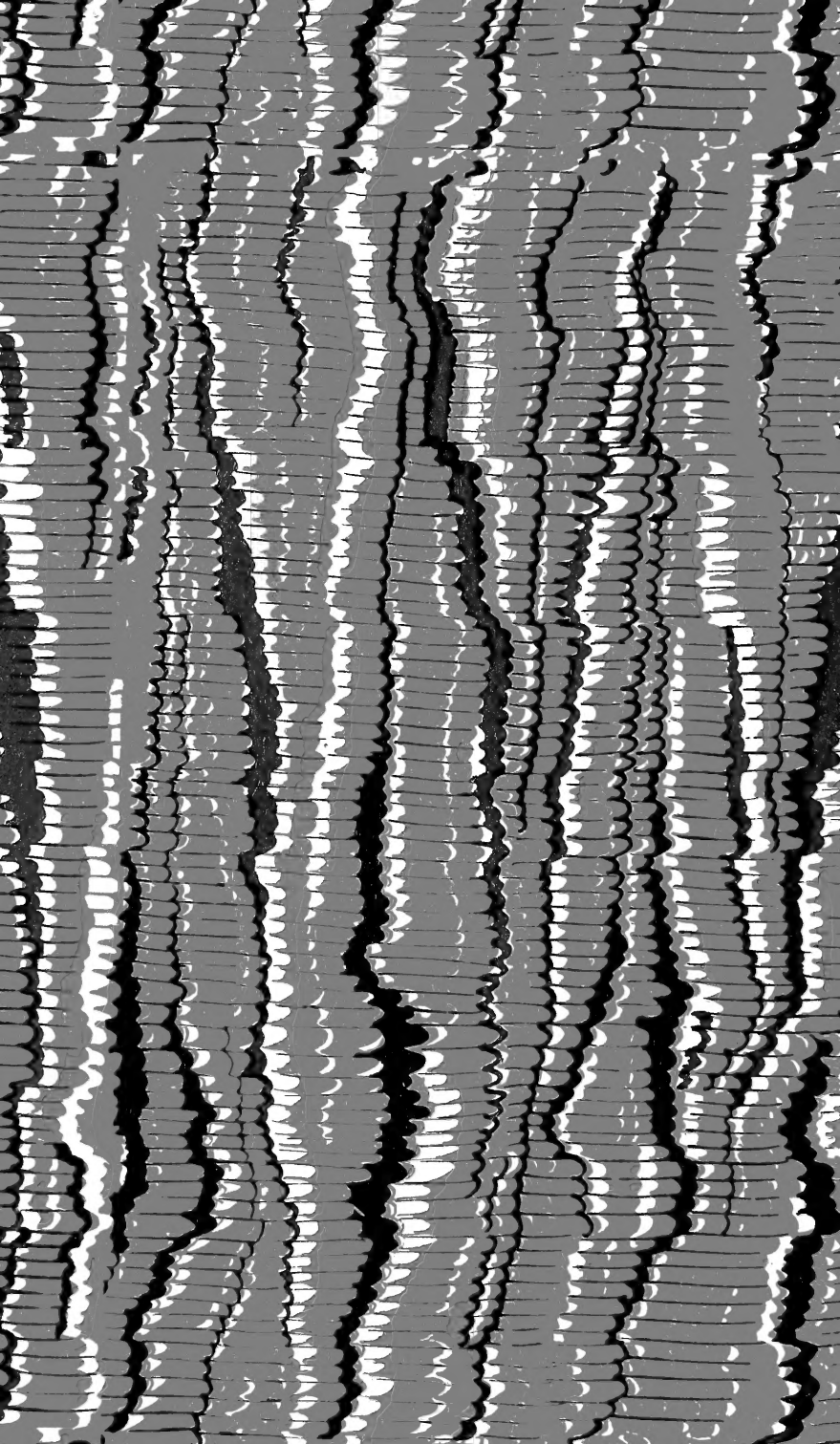

SMITHSONIAN INSTITUTION LIBRARIES



3 9088 01202 4642