



554

SCIENTIFIC LIBRARY



UNITED STATES PATENT OFFICE



29
19
1
11-169
D.O.

THE
LONDON, EDINBURGH, AND DUBLIN
PHILOSOPHICAL MAGAZINE
AND
JOURNAL OF SCIENCE.

CONDUCTED BY

LORD KELVIN, G.C.V.O. D.C.L. LL.D. F.R.S. &c.
GEORGE FRANCIS FITZGERALD, M.A. Sc.D. F.R.S.
AND
WILLIAM FRANCIS, Ph.D. F.L.S. F.R.A.S. F.C.S.

“Nec araneorum sane textus ideo melior quia ex se fila gignunt, nec noster vilior quia ex alienis libamus ut apes.” *Just. Lips. Polit. lib. i. cap. 1. Not.*

VOL. XLVII.—FIFTH SERIES.
JANUARY—JUNE 1899.

LONDON:

TAYLOR AND FRANCIS, RED LION COURT, FLEET STREET.

SOLD BY SIMPKIN, MARSHALL, HAMILTON, KENT, AND CO., LD.; WHITTAKER AND CO.;
AND BY ADAM AND CHARLES BLACK;—T. AND T. CLARK, EDINBURGH;
SMITH AND SON, GLASGOW;—HODGES, FIGGIS, AND CO, DUBLIN;—
PUTNAM, NEW YORK;—YEUVE J. BOYVEAU, PARIS;—
AND ASHER AND CO., BERLIN.

73625

21
S
P. 5

“Meditationis est perscrutari occulta; contemplationis est admirari perspicua Admiratio generat quæstionem, quæstio investigationem, investigatio inventionem.”—*Hugo de S. Victore.*

—“Cur spirent venti, cur terra dehiscat,
Cur mare turgescat, pelago cur tantus amaror,
Cur caput obscura Phœbus ferrugine condat,
Quid toties diros cogat flagrare cometas,
Quid pariat nubes, veniant cur fulmina cœlo,
Quo micet igne Iris, superos quis conciat orbes
Tam vario motu.”

J. B. Pinelli ad Mazonium.

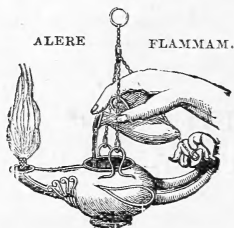

CONTENTS OF VOL. XLVII.

(FIFTH SERIES).

NUMBER CCLXXXIV.—JANUARY 1899.

	Page
Mr. Albert Campbell on the Magnetic Fluxes in Meters and other Electrical Instruments	1
Messrs. Edward B. Rosa and Arthur W. Smith on a Resonance Method of Measuring Energy dissipated in Condensers	19
Dr. E. H. Cook on Experiments with the Brush Discharge. (Plate I.)	40
Dr. van Rijckevorsel on the Analogy of some Irregularities in the Yearly Range of Meteorological and Magnetic Phenomena. (Plate II.)	57
Lord Kelvin on the Age of the Earth as an Abode fitted for Life	66
Mr. D. L. Chapman on the Rate of Explosion in Gases	90
Prof. Carl Barus on the Aqueous Fusion of Glass, its Relation to Pressure and Temperature	104
Prof. E. Rutherford on Uranium Radiation and the Electrical Conduction produced by it	109
Notices respecting New Books:—	
Dr. E. J. Routh's Treatise on Dynamics of a Particle ..	163
Susceptibility of Diamagnetic and Weakly Magnetic Substances, by A. P. Wills	164

NUMBER CCLXXXV.—FEBRUARY.

Dr. Thomas Preston on Radiation Phenomena in the Magnetic Field.—Magnetic Perturbations of the Spectral Lines	165
---	-----

	Page
Lord Kelvin on the Reflexion and Refraction of Solitary Plane Waves at a Plane Interface between two Isotropic Elastic Mediums—Fluid, Solid, or Ether	179
Prof. H. L. Callendar: Notes on Platinum Thermometry ..	191
Messrs. Edward B. Rosa and Arthur W. Smith on a Calorimetric Determination of Energy dissipated in Condensers .	222
Prof. Karl Pearson on certain Properties of the Hypergeometrical Series, and on the fitting of such Series to Observation Polygons in the Theory of Chance.....	236
Lord Rayleigh on James Bernouilli's Theorem in Probabilities.	246
Notices respecting New Books:—	
Drs. G. E. Fisher and I. J. Schwatt's Textbook of Algebra with Exercises for Secondary Schools and Colleges ..	251
Relative Motion of the Earth and Æther, by William Sutherland	252

NUMBER CCLXXXVI.—MARCH.

Prof. J. J. Thomson on the Theory of the Conduction of Electricity through Gases by Charged Ions	253
Mr. William Sutherland on Cathode, Lenard, and Röntgen Rays	269
Dr. R. A. Lehfeldt on Properties of Liquid Mixtures.—Part III. Partially Miscible Liquids	284
Mr. W. B. Morton on the Propagation of Damped Electrical Oscillations along Parallel Wires	296
Lord Kelvin on the Application of Sellmeier's Dynamical Theory to the Dark Lines D ₁ , D ₂ produced by Sodium Vapour	302
Lord Rayleigh on the Cooling of Air by Radiation and Conduction, and on the Propagation of Sound	308
Lord Rayleigh on the Conduction of Heat in a Spherical Mass of Air confined by Walls at a Constant Temperature.	314
Notices respecting New Books:—	
Dr. D. A. Murray's Elementary Course in the Integral Calculus.....	325
Proceedings of the Geological Society:—	
Mr. J. E. Marr on a Conglomerate near Melmerby (Cumberland)	326
Mr. Beeby Thompson on the Geology of the Great Central Railway, Rugby to Catesby	327
Prof. T. T. Groom on the Geological Structure of the Southern Malverns and of the adjacent District to the West	327

	Page
On the Heat produced by Moistening Pulverized Bodies: New Thermometrical and Calorimetrical Researches, by Tito Martini	329
Combination of an Experiment of Ampère with an Experi- ment of Faraday, by J. J. Taudin Chabot	331
Experiments with the Brush Discharge, by E. W. Marchant .	331

NUMBER CCLXXXVII.—APRIL.

Dr. C. Chree on Longitudinal Vibrations in Solid and Hollow Cylinders	333
Mr. R. W. Wood on some Experiments on Artificial Mirages and Tornadoes. (Plate III.)	349
Mr. J. Rose-Innes and Prof. Sydney Young on the Thermal Properties of Normal Pentane	353
Mr. R. W. Wood on an Application of the Diffraction- Grating to Colour-Photography	368
Dr. G. Johnstone Stoney on Denudation and Deposition . . .	372
Lord Rayleigh on the Transmission of Light through an Atmosphere containing Small Particles in Suspension, and on the Origin of the Blue of the Sky	375
Prof. Oliver Lodge on Opacity	385
Prof. J. J. Thomson: Note on Mr. Sutherland's Paper on the Cathode Rays	415
Notices respecting New Books:—	
Harper's Scientific Memoirs, edited by Dr. J. S. Ames..	417
Proceedings of the Geological Society:—	
Mr. W. Wickham King on the Permian Conglomerates of the Lower Severn Basin	417
Dr. Maria M. Ogilvie [Mrs. Gordon] on the Torsion- Structure of the Dolomites	419

NUMBER CCLXXXVIII.—MAY.

Mr. F. H. Pitcher on the Effects of Temperature and of Circular Magnetization on Longitudinally Magnetized Iron Wire	421
Dr. Edwin H. Barton on the Equivalent Resistance and Inductance of a Wire to an Oscillatory Discharge	433
Mr. L. N. G. Filon on certain Diffraction Fringes as applied to Micrometric Observations	441

	Page
Prof. Carl Barus on the Absorption of Water in Hot Glass (Second Paper)	461
Lord Kelvin on the Application of Force within a Limited Space, required to produce Spherical Solitary Waves, or Trains of Periodic Waves, of both Species, Equivoluminal and Irrotational, in an Elastic Solid	480
Dr. C. Chree on Denudation and Deposition	494
Notices respecting New Books:—	
Prof. Silas Holman's Matter, Energy, Force, and Work.	496
Messrs. J. Harkness and F. Morley's Introduction to the Theory of Analytic Functions	497
Proceedings of the Geological Society:—	
Mr. H. H. Arnold-Bemrose on the Geology of the Ash- bourne and Buxton Branch of the London and North- Western Railway—Ashbourne to Crake Low	498
Prof. J. B. Harrison and Mr. A. J. Jukes-Browne on the Oceanic Deposits of Trinidad	498
A Five-cell Quadrant Electrometer, by Prof. H. Haga	499

NUMBER CCLXXXIX.—JUNE.

Mr. Edwin S. Johonnott, Jun., on the Thickness of the Black Spot in Liquid Films	501
Mr. Albert Griffiths on the Source of Energy in Diffusive Convection	522
Mr. Albert Griffiths: Study of an Apparatus for the Determination of the Rate of Diffusion of Solids dissolved in Liquids	530
Mr. G. A. Shakespear on the Application of an Interference- Method to the Investigation of Young's Modulus for Wires, and its Relation to Changes of Temperature and Magneti- zation; and a further Application of the same Method to the Study of the Change in Dimensions of Iron and Steel Wires by Magnetization	539
Dr. G. Johnstone Stoney on Denudation and Deposition.— Part II	557
Mr. Gerald Stoney on the Quantity of Oxygen in the Atmo- sphere, compared with that in the Earth's Crust	565
Lord Rayleigh on the Calculation of the Frequency of Vibra- tion of a System in its Gravest Mode, with an example from Hydrodynamics	566
Notices respecting New Books:—	
Dr. F. A. Tarleton's Introduction to the Mathematical Theory of Attraction	572

	Page
H. Poincaré's Théorie du Potentiel Newtonien	573
Dr. Florian Cajori's History of Physics in its Elementary Branches, including the Evolution of Physical Laboratories	575
Proceedings of the Geological Society:—	
Mr. Frank Rutley on a small Section of Felsitic Lavas and Tuffs near Conway (North Wales)	575
Mr. Joseph Thomson on the Geology of Southern Morocco and the Atlas Mountains	576
Index	577

PLATES.

- I. Illustrative of Dr. E. H. Cook's Paper on Experiments with the Brush Discharge.
- II. Illustrative of Dr. van Rijkevorsel's Paper on the Analogy of some Irregularities in the Yearly Range of Meteorological and Magnetic Phenomena.
- III. Illustrative of Mr. R. W. Wood's Paper on some Experiments on Artificial Mirages and Tornadoes.

THE
LONDON, EDINBURGH, AND DUBLIN
PHILOSOPHICAL MAGAZINE
AND
JOURNAL OF SCIENCE.

[FIFTH SERIES.]

JANUARY 1899.



I. *The Magnetic Fluxes in Meters and other Electrical Instruments.* By ALBERT CAMPBELL, B.A.*

IN all electrical measuring instruments in which the deflecting or controlling forces are electromagnetic, the magnetic fluxes and fields are of great importance, and yet there seem to be no tables published which give even rough measurements of these, the result being that many people who are thoroughly expert in the use of instruments have no idea whatever of the order of magnitude of the magnetic fluxes occurring in the very commonest instruments. In order, therefore, to fill this gap to some extent, I have recently carried out a series of experiments on the subject, and although the list of instruments thus tested is not very extensive or complete, I have been able to include in it a good many of the more familiar types. As individual instruments of the same type vary somewhat amongst themselves, it would have been waste of time to have aimed at great accuracy in these measurements. Accordingly, whilst guarding against large errors in general, I have been content in one or two cases with results which only indicate the order of magnitude of the quantity measured.

In most cases the quantity determined has been B , the magnetic flux density or number of induction-tubes per square centimetre sometimes through iron, sometimes through air.

* Communicated by the Physical Society: read Oct. 28, 1898.

Phil. Mag. S. 5. Vol. 47. No. 284. Jan. 1899.

B

In some cases Φ , the total flux, was measured, and for several of the meters determinations of the power lost in their various parts were also made.

Methods of measuring B.

METHOD I. Except when the fluxes were alternating, the method used was the well-known way with a ballistic galvanometer. A search-coil in circuit with the galvanometer either had the flux suddenly reversed in it, or was pulled quickly out of the field. For many of the experiments small and very thin search-coils had to be used. For instance, in one of the meters, the available air-gap was only 1 millim. across. The bobbins of these small coils were made by cementing together one or more round microscope cover-glasses between larger strips of mica for the ends; they were wound with from 10 to 200 turns of silk-covered copper wire of 0.075 millim. diameter. Much thicker wire was used when it was desirable to have the resistance of the galvanometer-circuit low. The smoothness of the mica cheeks allowed the coils to be withdrawn from position with the necessary quickness.

Fig. 1.

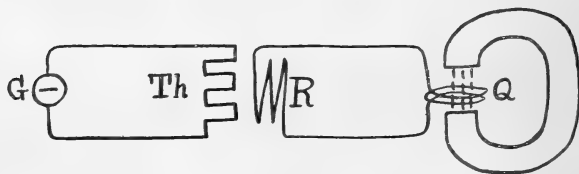

The galvanometer was calibrated from time to time by means of a standard pair of coils whose mutual inductance was accurately known. As the measurement of small fluxes by the ballistic method presents no difficulty, and requires only ordinary instruments, further description is needless.

METHOD II. When, however, the small flux is an alternating one, the voltage set up in the search-coil is more difficult to measure; accordingly two special methods were here used. In the more accurate of these two methods the search-coil Q (fig. 1), through which the flux was made to pass, instead of being in circuit with a ballistic galvanometer, was joined directly to a resistance-coil R , laid along one set of junctions of a minute-thermopile Th , which last was connected with a sensitive galvanometer G . The resistance-wire was of manganin (silk-covered) and was placed along the junctions so as to be non-inductive, and to avoid

producing eddy-currents. The thermopile consisted of ten pairs of thin iron and nickel wires each 7 millim. long. These metals were chosen as their thermo-electric lines are far apart, and almost parallel to one another.

Some years ago the writer showed (Proc. Roy. Soc. Edin. July 1887) that a thermopile used thus could give a fairly accurate measurement of the current through the resistance-wire, the ultimate deflexion being proportional to the square of this current. Hence, for a given frequency, the mean square of the P.D. at the terminals of the search-coil was proportional to the deflexion. Each time it was used the combination was calibrated in the following manner:—A measured current of 1 ampere from the alternating supply circuit used was passed through a non-inductive resistance of 0·2 ohm, and the resulting P.D. of 0·2 volt was applied to the ends of the resistance R. From the observed deflexion of the galvanometer the mean square of the volts per division was found*. In all cases when the search-coil was in circuit the frequency n was observed, being measured by a frequency-teller. If the resistance of the search-coil be negligible, and if the flux follows the sine law, we have

$$v_2 = 10^{-8} \times 2\pi n N_2 B s_2,$$

where

v_2 = voltage shown by galvanometer,

n = frequency,

N_2 = number of turns in search-coil,

s_2 = area of search-coil.

and

$$B = \sqrt{\text{mean square } B}.$$

The other method, which was by means of a telephone, was a rougher way, and will be described below.

In Table I. are given some of the results obtained in the case of the simpler instruments, the third column giving the resistance of the instrument, the fourth column its full load, and the fifth the mean value of B at that load. As far as possible the positions from which the mean value of B were obtained were chosen so as to give an idea of the *working* flux-density, and except where otherwise stated the values given refer to full load.

* The thermopile method of measuring small voltages is now in use in the German Reichsanstalt.

TABLE I.

No.	Name.	Resistance, Ohms.	Full Load.	B (mean).
1.	Siemens Electrodynamometer.....	0.58	4 amps.	80
	0.0156	20 amps.	18
2.	Kelvin Ampere-Balance	0.58	10 amps.	65
3.	Bifilar Mirror Wattmeter (after Dr. Fleming).	0.0078	50 amps.	55
4.	Ayrton and Mather D'Arsonval Galvanometer.			
5.	Weston Voltmeter	7.4	0.2 volt	870
6.	Davies Voltmeter (Muirhead) ...	481	3 volts	400
7.	Evershed Ammeter	0.00043	100 amps.	700
8.	Ayrton and Perry Magnifying Spring Voltmeter.	30	18 volts	14,200
9.	Richard Recording Ammeter	7×10^{-5}	500 amps.	580
10.	Dolivo Voltmeter	56	15 volts	75
11.	Nalder Voltmeter	586	40 volts	70
12.	Any Tangent Galvanometer	Defl. = 45°	0.26
13.	Kelvin Astatic Mirror Galvano- meter.	13,000	0.008
14.	Evershed Ohmmeter, Old Type	(100 volts)
15. New Type...	(200 volts)	(about 10)
16.	Campbell Frequency-Teller.....	(500)	(0.2 amp.)	280
17.	Bell Telephone (double pole)	126	3000
18.	Ayrton and Perry Variable In- ductance Standard.	10.6	(1 amp.)	20
19.	Standard Inductance Coil }..... (L=0.2 henry.			

As the numbers in the above Table throw an interesting light on the behaviour of many of the instruments it seems desirable to discuss them more fully in order.

(1) *Siemens Electrodynamometer*.—Measurements taken at the middle and the top of the swinging coil (of 4 turns) in direction perpendicular to the plane of the fixed coils gave $B=120$ and 40 respectively for the thin coil, and $B \doteq 21$ and 16 for the thick. It will be seen that when the thick coil is used the deflecting field is quite comparable with the earth's field.

This, of course, introduces an error with direct currents unless care is taken to place the instrument so that the direction of the earth's field is at right angles to that of the deflecting field, and in the proper sense, *i. e.* with the instrument looking east or west according to the direction of the current in the swinging coil. The above results show that the maximum variation at 15 amps. introduced by wrong placing (*viz.*, due to a field equal to twice that of the earth, or 0.36) would be about 2.5 per cent. of the mean deflecting field. This was verified by placing the electrodynamometer on a well-levelled turntable, and connecting its thick coil with a

quite steady source of continuous current by means of twisted flexible leads. In Table II. are shown the values of the current indicated by the instrument when turned into various positions, the first column giving the direction towards which the front was turned in each case.

TABLE II.

Direction.	Apparent Amperes.	Variation from Minimum.
N. . . .	15·00	0
W. . . .	15·20	1·3 %
S. . . .	15·32	2·1 %
E. . . .	15·20	1·3 %

It will be seen that the extreme variation is 2·1 per cent., which agrees (within the limits of error of the instrument) with the 2·5 per cent. variation deduced from the observed fields. For lower currents the variation is much more, being in the inverse ratio of the current. With the thin coil the field due to the fixed coil is so much stronger that the variation is slight except at the very lowest currents.

The thick coil had 7 turns and an area of about 46 sq. centim., and the total maximum flux at full load was found to be 1850, giving mean $B \doteq 40$. At full load the power wasted is 6·2 watts and 9·3 watts for the thick and thin coils respectively.

(2) *Kelvin Balance*.—The total flux through the central space of the coils was got by winding the search-coil round the supporting pillar, and taking throws by reversing the current. The resultant flux was about 1600 (for full load). By the astatic arrangement of the swinging coils the instrument is made independent of the earth's field. The self-inductance is about 0·0016 henry.

(3) *Bifilar Mirror Wattmeter*.—This instrument has ranges up to 50 or 100 amperes at 10 volts and upwards. The numbers given refer to the fixed series coil. With direct currents it is clear that precautions have to be taken to eliminate the effects of the earth's field.

(4) *D'Arsonval Galvanometer*.—This was a ballistic one (made by Paul) with a narrow swinging coil of the Ayrton-Mather type. The B given in the Table is that in the air-gap in the neighbourhood of the moving coil; it would seem to be sufficiently great to be practically unaffected by the magnetism of the earth. Besides, as it is an instrument for use in a fixed position, it is only the effect of variable external fields that need to be taken into account. This point

will be discussed a little further on. To get an idea of how the flux in the steel varies from point to point along the annular magnet, an experiment was made with a ring-magnet of rectangular section, having an air-gap as shown in fig. 2. A small search-coil which could only just slip along the magnet was moved by jerks into successive positions, and the corresponding changes in the flux were calculated from the throws on a ballistic galvanometer in circuit with the coil. Fig. 2 shows the result, the radial breadth of the shaded part being drawn proportional to the flux in the steel at each position. Fig. 3 is a similar diagram for an ordinary bar-magnet. In the ring-magnet the available air-gap flux was less than one third of the maximum flux at *aa*.

(5) *Weston Voltmeter*.—It will be noticed that B in the air-gap of this instrument is very high, viz. 870. This might lead one to suppose that the earth's field would have no perceptible effect on its readings, but it must be remembered that the flux induced in a piece of iron or steel in the earth's field is usually very many times greater than the flux in air due to the earth alone. This can be easily shown by connecting a coil with a ballistic galvanometer and reversing the coil with regard to the earth's field first by itself and then with a soft iron core in it. The throws of the galvanometer will be enormously increased by the presence of the core. To find how far the earth's field affected the flux in a permanent magnet with a moderate air-gap, a coil was wound upon the circular one shown in fig. 2, and was connected with a galvanometer. The magnet was then turned round so as to quickly reverse the action of the earth's horizontal field upon it. The resulting throw on the galvanometer showed that the maximum B in the steel, which was about 5000, was only changed by 3 lines per sq. cm., *i. e.* by less than 0.1 per cent. The behaviour of the Weston magnet tallies with this, for when the instrument, with a steady voltage on its terminals, was turned round to face each point of the compass, no change in the reading could be detected, although the scale could be read to about 1 in 1000*.

(6) *Davies Voltmeter*.—In this instrument one side of the rectangular moving coil moves in a narrow cylindrical air-gap between specially shaped pole-pieces of a strong permanent magnet. It gives a maximum angular deflexion of about 210°.

(7) *Evershed Ammeter*.—A coil of 6 turns magnetizes two small pieces of iron with a movable piece between them,

* At Professor Ayrton's suggestion I have re-tested the instrument at the higher readings, and have detected a variation of about 0.1 per cent.

B was measured at about the end of one of the fixed pieces where the movable piece faces it.

(8) *Ayrton and Perry Magnifying Spring Voltmeter*.—The small iron tube, which is surrounded by a coil and pulled down by it, is 7.2 centim. long, and the iron has a section of about 0.12 sq. centim. The number given in the table is the average B in the iron for the whole length of the tube for a load of 15 volts, *i. e.* 0.8 of full load.

Fig. 2.

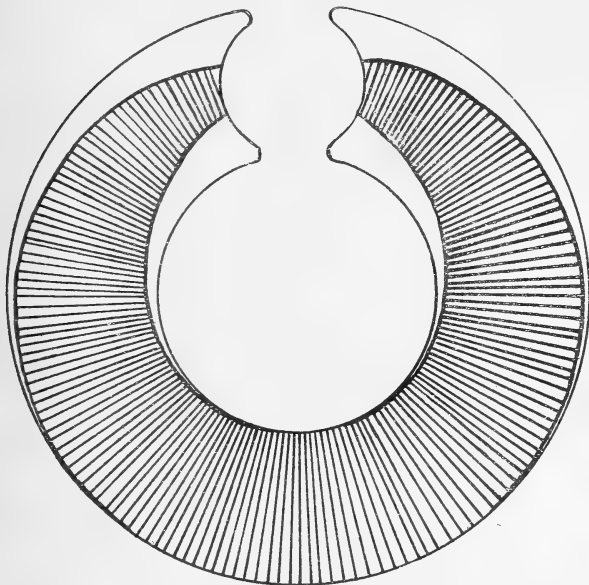
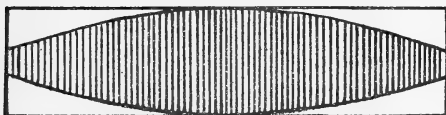

Fig. 3.



(9) *Richard Recording Ammeter*.—This has two solid iron cores (each 4 sq. centims. cross-section) round which the current is carried by a single turn of copper strip; an iron armature carrying the pointer is attracted by these cores. B was measured between one core and the armature. It will be seen that the total flux is large; thus a strong deflecting force is obtained which makes the friction of the recording pen of less account, but on the other hand much error from hysteresis comes in.

(10) *Dolivo Voltmeter*.—Here a thin wire of soft iron is drawn down into a solenoid. The value given is for the hollow core of the coil (including the wire).

(11) *Nalder Voltmeter*.—In this a small piece of soft iron moves in the magnetic field produced by a coil outside it. The number in the table is for the middle of the space within the coil.

(12). *Tangent Galvanometer*.—When the deflexion = 45° , the resultant field = earth's field $\div \cos 45^\circ$
 $\doteq 0.26$ (in London).

(13) *Kelvin Astatic Mirror Galvanometer*.—The galvanometer was made very sensitive and almost unstable by means of the controlling magnet. The mean control field (for this condition) was found by measuring its sensitivity and comparing it with that when the earth's field alone was used. The deflecting field for 1° would be less than 0.00002, and depends on the degree of astaticism of the suspended magnets.

(14) *Evershed Ohmmeter*—(Old type; polarized, astatic). The number given is a rough approximation to the B due to the shunt-coil alone at 100 volts. About the middle of the scale the field due to the series-coil would have the same value.

(15) *Evershed Ohmmeter*—(New type, with soft iron needle). The B given is that due to the shunt-coil alone (at 200 volts). It is clear that the earth's field cannot introduce much error. In any case the errors due to external fields can be eliminated (as the makers direct) by reversing the current and taking the mean of the readings.

(16) *Campbell Frequency-Teller*.—The B is measured between the vibrating strip and the attracting pole of the electromagnet. It will be seen that only a quite moderate field is required to throw the spring into strong vibration when it is adjusted to the right length for resonance.

(17) *Double Pole Bell Telephone*.—The diaphragm was so close to the poles of the permanent magnet as to form an almost closed magnetic circuit. A small search-coil was wound round one of the pole-pieces (area = 0.24 sq. centim.), and the diaphragm was then laid in its place. A throw of the galvanometer was got by pulling off both the diaphragm and the search-coil. Thus the flux-density given refers to the pole-pieces.

(18) *Ayrton and Perry Variable Standard of Self-Inductance*.—With the pointer at 0.038 henry, the total flux within the inner wooden bobbin was about 5200 for 1 ampere.

(19) *Self-Inductance Standard* (L = 0.20 henry).—This was a coil of 1158 turns of insulated copper wire (diameter 1.24 millim.), the outer diameter of the coil being 22 centim.

and the height 9 centim. The B given in the table is the average for the whole cross-section of the coil at the middle of its height. The total flux corresponding to this was 17,500. B at the centre of this cross-section was 53.

In addition to the instruments already discussed, experiments were also made upon a number of meters of different types, some being for direct, and some for alternating currents. As some of the types vary in construction from year to year, a few words of description in each case will make the results clearer.

Aron Watt-hour Meter (1894 type).—Range to 50 amps. at 100 volts. Two pendulums, each carrying shunt-coils, are acted on by series-coils under them, one being accelerated and the other retarded. With both series and shunt-currents passing (at full load) the mean B between the fixed and movable coils was about 70.

Frager Watt-hour Meter.—Range to 10 amps. at 100 volts. A meter of the "Feeler" type, in which the shunt and series coils form an ordinary wattmeter, whose deflexions are integrated at intervals. The mean B was measured as near the centre of the shunt-coil as possible.

At full load	$B = 63,$
With shunt-current alone . .	$B = 13,$
With series-current alone . .	$B = 50.$

Hookham Direct-Current Ampere-hour Meter.—Range to 100 amps. A small disk, surrounded by mercury which carries the current, is cut twice by part of the magnetic flux from a strong permanent magnet (of cross-section 7.5 sq. centim.). The disk is thus caused to turn. On the same spindle is a brake disk of copper (5.4 centim. diameter), which is also cut by a part of the flux from the same permanent magnet. Unfortunately it was not possible to take the meter to pieces, so the driving flux could not be measured. By slipping a search-coil along the permanent magnet, the total leakage was found to be over 26,000 lines. The total brake flux passes through the disk at four air-gaps, two and two in series, and has a value of about 5000 lines. The 8 pole-pieces which direct the flux have cross-sections of 1.53 centim. each. In two of them the iron near the air-gap is turned down so as to leave only a thin neck of about 0.12 sq. centim. cross-section. This is supposed to increase the permanence of the flux. At these necks more than $\frac{1}{4}$ of the total flux leaks from the iron. Whether they increase or diminish the permanence seems quite uncertain. The mean flux density at the four air-gaps was found to be about 1020.

The power spent in the meter at full load = 12.8 watts.

The power spent in turning the spindle (at 2.2 revolutions per second) with full load was measured by the method (1) described below, and was found to be 0.016 watts*. Hence the efficiency of the meter as a motor = 0.125 per cent.

Kelvin Ampere-hour Meter.—Range to 600 amperes. In this a thin iron core, kept highly magnetized by a shunt-current, is drawn down into a solenoid which carries the main current. The solenoid had 6 turns (*i. e.* 3600 ampere-turns at full load), and was about 16 centim. long. At full load the flux density at the lower end of the solenoid was over 250. With the shunt-current alone the total flux through the moving coil and core was about 330.

Elihu Thomson Watt-hour Meter.—Range to 50 amperes at 100 volts. This meter consists of a small ironless motor, in which the series-current goes through the field-magnet coils and the shunt-current through the armature. On the armature spindle is a brake disk of copper (13.5 centim. diameter), which passes between the narrow air-gaps of three permanent magnets of the shape shown in fig. 4. These magnets are often of different strengths, being chosen to give the proper brake-force for each individual meter. Their polar faces are about 7.5 sq. centim. The mean B in the air-gaps was about 700. By the method of placing the magnets the greater part of the flux acts on the brake disk. By slipping a search-coil along one of the magnets it was found that the total flux at a was about 15000, making B about 7000. Of this flux nearly one half remains in the steel as far as the section at b .

Fig. 4.



Driving Flux.—Without the shunt-current the full load current gives mean $B \doteq 130$ along the axis of the series-coils. The shunt-current at 100 volts gives a field at right angles to this in which $B = 10$. The shunt-current also passes through a “compounding” coil fixed coaxially in one of the

* After the author had measured the motor-efficiencies of several meters, Mr. Sidney Evershed somewhat anticipated him by announcing (Institution of Electrical Engineers, May 12th, 1898) one or two similar results, making no mention, however, of the method by which the results were obtained.

series-coils for the purpose of overcoming friction at the lower loads. The B due to this starting coil alone is about 3. There is a small stray field from the series-coils perceptible at the brake disk, but as it is less than the $\frac{1}{300}$ part of the field due to the permanent magnets its effect may be neglected.

Effect of the Earth's Field.—Since the driving flux density at full load is only 130, it is clear that at the lower loads the rate of the meter may be considerably affected by the earth's field. To test this point the meter was levelled up on a turntable (as in the case of the electro-dynamometer already described), and a constant load of 4.625 amperes at 100 volts was kept on it. The load was measured by a Kelvin balance and a reflecting multicellular voltmeter. The rate of the meter, *i. e.* spindle revolutions per watt-second, was then determined

- (A) with alternating current ;
- (B) with direct current, the earth's field helping the driving field ;
- (C) the same, with the earth's field opposing the driving field.

Table III. shows the results of the tests.

TABLE III.

Position of Meter.	Current.	Rate.
(A) Facing East.	Alternating at 80~ per second.	0.0002125
(B) „ West.	Direct.	0.0002135
(C) „ East.	Direct.	0.0002212

It will be seen from (B) and (C) that by turning the meter round through 180° its rate at $\frac{1}{10}$ load is altered by 3.6 per cent., which is exactly what might have been predicted from the value of B given above. The rate with alternating current does not lie between the rates (B) and (C) as it ought, but is about 0.5 per cent. slower than (B).

Power Spent in Meter.—The resistance of the series-coil $\doteq 0.0066$ ohm, and that of the shunt-coil $\doteq 2030$ ohms ; hence the power spent in heating the coils $= 16.5 + 4.9 = 21.4$ watts.

The power spent in actually driving the meter (at full load) was measured by two methods as follows :—

(1) An arm of about 10 centim. long was attached to the spindle of the meter (at right angles to it). With full load

switched on, the tangential force f necessary to hold at rest the end of this arm was measured by the extension of a spiral spring which had been calibrated by known weights.

Then

$$\text{Power (in watts)} = 10^{-7} \cdot f \cdot 2\pi r \cdot \frac{n}{t},$$

where

r = length of arm,

$\frac{n}{t}$ = number of revolutions per second when the spindle is free to move.

(2) In the second method the shunt-circuit was disconnected and joined directly to a sensitive galvanometer with a resistance of 12,000 ohms in circuit. A measured current was sent through the series-coils, and the spindle was turned at about the full rate. Thus the meter acted as a dynamo and gave a deflexion on the galvanometer. By watching the galvanometer-scale it was not hard to keep this deflexion steady, and from the known calibration of the galvanometer the voltage given by the armature was obtained. The total E.M.F. multiplied by the normal shunt-current (0.0493 amp.) gave the driving-power.

Method (1) gave for the driving-power at full load 0.020 watt, whilst method (2) gave 0.021 watt. Hence the efficiency of the meter as a motor is only 0.095 per cent.

Hookham Alternating-Current Watt-hour Meter.—Range to 10 amperes at 100 volts. In this meter a solid iron core forming an almost closed magnetic circuit is magnetized by a shunt-coil, which latter, by reason of its large inductance, carries a current which lags behind the main current by 50° to 60° . A smaller U-shaped piece magnetized by the main current has its poles close to the upper pole of the larger iron core, and one of the poles carries a copper screen. A small aluminium disk (8.8 centim. in diameter), partly between the poles, is turned by the rotary magnetic flux thus produced. The brake force acts on the same disk, and is due to a tall permanent magnet about 20 centim. high (with a narrow air-gap), as shown in fig. 5.

Brake Flux.—The maximum flux in this magnet was found to be near P, and had the value 19,820, corresponding to $B=8800$. Of this only 4400 lines ultimately cut the disk, much being lost by cross leakage from Q and S to the opposite limb. Thus less than $\frac{1}{4}$ of the maximum flux is made use of. The mean B between the poles was found to be 650.

Driving Flux.—The distribution of the somewhat complicated alternating field was traced by the following method, which also gave rough quantitative results. A telephone T

Fig. 5.

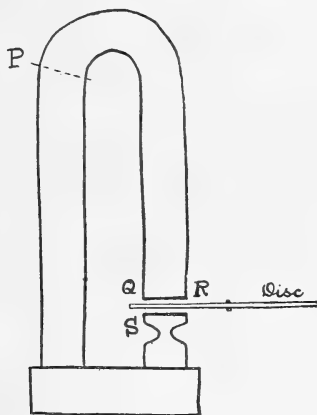

(fig. 6) was arranged in a circuit with the search-coil F and the low-resistance strip H K in such a way that the strip could be switched out of circuit at will. One of the connexions to H F was through a sliding contact, so that the

Fig. 6.

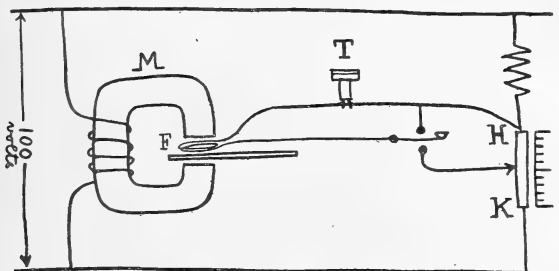

resistance of the part in the telephone-circuit could be varied from 0.05 ohm downwards. A current of 1 ampere was maintained in the strip and was from the alternating circuit which supplied the meter load. With the strip out of circuit the search-coil was moved into various positions, and the distribution of the alternating flux observed by means of the sound in the telephone. To measure the flux at any position H K was set to such a value that the small P.D. introduced by it into the telephone-circuit gave a sound of the same loudness as that given when the search-coil was placed in the flux. The absolute values given by this method came out 10

to 15 per cent. too small; but it proved a very convenient way of comparing the flux-densities at various positions. It was thus found that when the main current (full load) was switched on in addition to the shunt-current, the flux-density under the middle pole was nearly doubled. The most curious fact brought to light by the method was that across the air-gap of the permanent magnet a considerable alternating flux is induced, the value of B at that position being actually about $\frac{1}{4}$ of that between the poles of the shunt-magnet with the shunt-current alone. The permanent magnet forms a kind of secondary magnetic circuit directing around itself the alternating eddy-currents in the disk. Whether this has any sensible demagnetizing effect upon the permanent magnet the writer has not determined.

The fluxes were measured more exactly by the method of the search-coil and thermopile described above. With shunt alone the root of mean square B was about 50 in the air-gap and 800 in the iron core just above the shunt-bobbin. The shunt-current at 100 volts ($86 \sim$ per sec.) was found to be 0.031 ampere. If the current followed a sine curve its maximum value would be 0.044. When a direct current of this value was tried the fluxes produced were much larger than those with the (supposed) equivalent alternating current. This is partly due to the fact that the shunt-current does not follow the sine law, but is no doubt also due to the existence of eddy-currents in the iron core. That these currents even in the disk spread the flux and reduce the flux-density in the air-gap was shown qualitatively by placing a search-coil, connected with a telephone, in the air-gap of a ring electromagnet excited by alternating current. The sound in the telephone was lessened when a copper disk was held near the coil in the air-gap. The search-coil and thermopile method showed that the flux-density had been reduced by 8 per cent.

To find how the core-flux varied with alteration of the voltage on the shunt-coil, by the same method the B just above the shunt-bobbin was measured for a number of voltages from 20 up to 100 volts. It will be seen from the curve in fig. 7 that B is very nearly proportional to the potential-difference. In practice it is found that the speed of rotation is very nearly proportional to the voltage.

Power spent in Meter.—To approximate to the amount of power spent by reason of hysteresis when the shunt-current alone is on, the iron was carried through a cycle by means of direct current of such amount as to give a maximum B nearly corresponding to that given with alternating current at 100 volts. The curve obtained is shown in fig. 8.

Fig. 7.

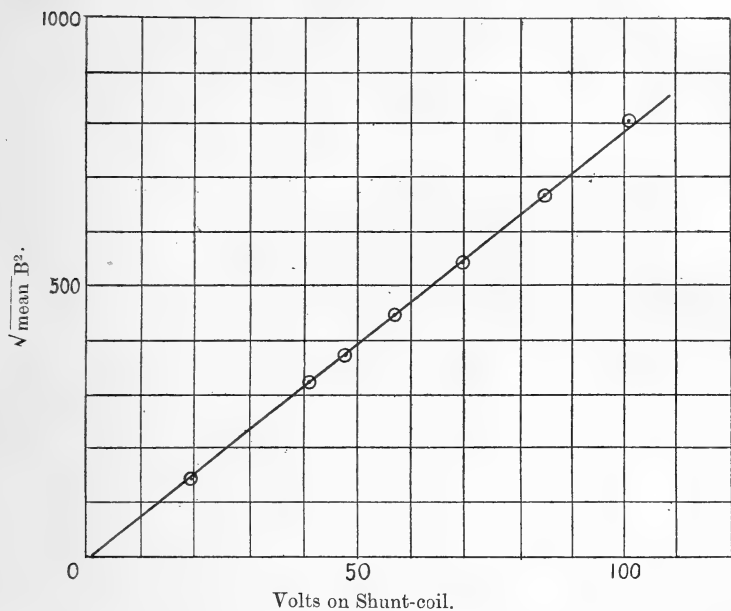
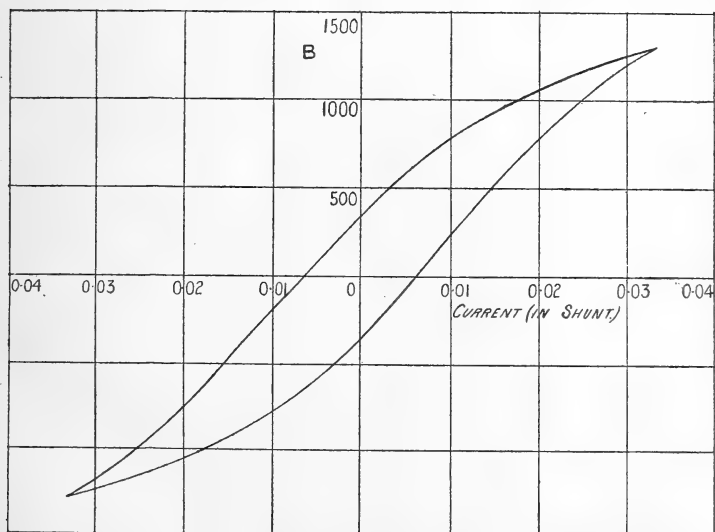

Fig. 8.



From this curve it is not possible to get the exact value of the hysteresis loss, as the iron core is not a uniformly magnetized closed circuit. To get an idea, however, of the amount of the power wasted by hysteresis, let us suppose that the magnetic circuit is equivalent to a uniform iron ring of the same cross-section as the core of the shunt-coil, uniformly wound with the same number of turns n_1 as the shunt-coil* (carrying the same current), and traversed by a flux equal to that at the part of the meter-core for which the curve in fig. 6 was taken.

Let c = current at any moment,

and s = section of ring.

Then

Hysteresis-loss in joules per cycle

$$\begin{aligned} &= \int c \, dv = 10^{-8} n_1 \int c \, d\Phi = 10^{-8} n_1 s \int c \, dB \\ &= 10^{-8} n_1 s \times (\text{area of curve}) \\ &= 10^{-8} \times 1200 \times 3.7 \times \text{area} \\ &\doteq 0.00114. \end{aligned}$$

\therefore at 86 ~ per second,

$$\text{Power spent} \doteq 86 \times 0.00114 = 0.098 \text{ watt.}$$

It was found by direct measurement that the actual power spent in the meter (with the shunt-current alone) was far larger than this. Accordingly measurements were made of the rise of temperature of the iron core by means of an iron-nickel thermopile. Three junctions of the pile were bound against the iron, which had its surface well insulated with paint. A pad of wadding was tied over the spot, and the thermopile was connected with a suitable galvanometer. The shunt-current was switched on for 120 seconds, the deflexion being read at intervals, and on breaking the current the cooling was observed for several minutes. The thermopile and galvanometer were calibrated with a known difference of temperature, and the curves of heating and cooling were drawn. The curve of heating was then corrected by means of the other curve, and thus the heating of the iron (corrected for cooling) was found.

At a spot just above the shunt-bobbin the corrected rise of temperature was $0^{\circ}.87$ C., whilst near the air-gap it was only about half of this. Taking account of this last fact, we may

* The exact value of n_1 was not known, but the value (1200) used was estimated from the resistance and gauge of the shunt-wire and the size of the coil.

take that a volume of about 61 c.c. was raised in temperature by $0^{\circ}\cdot87$ C.

Now

$$\text{Power spent} = 4\cdot2 \frac{\sigma \cdot VD \cdot \delta T}{t} \text{ watts,}$$

where σ = sp. heat of the iron,

V = volume „ „

D = density „ „

δT = temperature-rise (corrected),

t = time in seconds;

therefore from the results above,

$$\text{Power} \doteq 1\cdot58 \text{ watts.}$$

Since the hysteresis-loss is about 0·10 watt, it will be seen that the eddy-current loss $\doteq 1\cdot48$ watts.

The power lost by eddy-currents in the disk was similarly measured, and was found to be about 0·02 watt.

In the shunt-coil the C^2R loss = 0·57 watt ; and hence the total copper and iron losses = 2·17 watts.

Direct Measurement of Total Power.—The total power given to the meter was measured by the three-voltmeter method, in which was used a reflecting electrostatic voltmeter accurate to about 1 in 1000 at all the points of the scale required. The result obtained was 2·06 watts, which agrees fairly well with the total watts shown by the other methods.

Driving-Power.—The driving-power at full load was also measured by the method of the spring-balance described above ; it was found to be 0·00073 watts. Taking account of the series-coil (whose resistance was 0·009 ohm) the total power spent at full load is over 3 watts ; and hence

$$\text{Motor efficiency} \doteq 0\cdot024 \text{ per cent.}$$

Scheefer Alternating-Current Watt-hour Meter.—Range to 10 amperes at 200 volts. In this meter a pile of **E**-shaped iron stampings has the series-coil on one outer limb and the shunt-coil on the other. An aluminium cylinder is turned by the rotary field thus produced, and on the same spindle is a brake disk with a single magnet exactly like those in the Elihu Thomson meter.

The mean B between the poles of this magnet was about 480. With the shunt-current alone the $\sqrt{\text{mean } B^2}$ between the shunt-pole and the driving cylinder was 570. The total power spent with the shunt alone on is 11·5 watts, of which 7·1 watts are due to C^2R loss.

Shallenberger Alternating-Current Ampere-hour Meter.—Range to 20 amperes. A series-coil (of about 50 turns) and
Phil. Mag. S. 5. Vol. 47. No. 284. Jan. 1899. C

a small short-circuited secondary coil, with their axes at an angle of about 45° , produce a rotary field by which is turned a small disk with a soft iron rim. The brake-force is obtained by air-friction on four aluminium vanes.

By the search-coil and thermopile method it was found that inside the series-coil

$$\sqrt{\text{mean } B^2} \doteq 100.$$

Power spent in Meter.—The resistance of the series-coil was 0.025 ohm ; hence the power spent in it = 10.0 watts.

The power spent in the copper stampings which form the secondary coil was found by measuring their rise of temperature with a small copper-iron junction. This rise (at full load) was found to be about $0^\circ.33$ C. per minute, the cooling being negligible. The volume of copper was about 21.4 c.c. ; whence the power spent = 0.40 watt.

The driving-power was found to be 0.0069 watt ; therefore the motor efficiency = 0.066 per cent.

Current in Secondary Coil.—The current in the short-circuited secondary coil could not be measured directly. Calculating from the dimensions of the coil, however, the resistance was found to be 8.5×10^{-6} ohm. From this and the value of the power (0.40 watt) we find that the secondary current attains the extraordinary value of 220 amperes.

For the sake of comparison some of the above results are collected in Table IV.

TABLE IV.

Name.	Driving B.	Brake B.	Power spent.	Motor Efficiency.
Elihu Thomson	130	700	watts. 21.4	per cent. 0.095
Hookham (direct curr.) ...	(not measured)	1020	12.8	0.125
Hookham (alternat. curr.)	50	650	3.2	0.024
Shallenberger	100	10.4	0.066

In conclusion, it will be noticed that in motor meters the driving-flux density is of the order 100 and the brake B from 500 to 1000 ; also that the motor efficiencies are all very small, particularly in the case of the alternating-current meters. In all of them the greater part of the power taken is spent in heating conductors (either by eddy-currents or otherwise). If a small fraction of this wasted energy could be employed to overcome with certainty the friction at the lowest loads, a great advantage would be gained thereby.

June 7th, 1898.

II. *A Resonance Method of Measuring Energy dissipated in Condensers.* By EDWARD B. ROSA and ARTHUR W. SMITH*.

THAT the dielectric of a condenser becomes warmed when an alternating electromotive force is applied to the terminals of the condenser has long been known, and the study of this heating effect has been undertaken by numerous observers. Kleiner † used a thermo-electric couple imbedded in the dielectric to measure the rise of temperature, and noted a considerable heating effect in ebonite, gutta percha, glass, and mica, but none at all in paraffin and kolophonium. He reports that in spite of all attempts by variations of the conditions of the experiment, no heating could be detected in these two last-named substances. On the other hand, Boucherot ‡ has made paraffin-paper condensers for use on the 3200-volt commercial circuits of Paris, some of which became so hot in use that they were obliged to be cut out. Boucherot says of the heating effect that if a condenser rises as much as 30° C., it should be rejected. That this is good advice is evident from the fact that paraffin melts at 54° C.; and hence when 30° C. above the temperature of a summer's day (say, 25° C. or 77° F.), the paper would be floating in melted paraffin.

Bedell, Ballantyne, and Williamson § report experiments upon a paraffin-paper condenser of 1.5 microfarad capacity, the efficiency of which was found to be 95.6 %, or 4.4 % lost in heat. The loss was determined by a three-voltmeter method, similarly to measurements on a transformer. It was put upon a 500-volt circuit at a frequency of 160, and the current was therefore about 0.7 ampere, the apparent watts about 350, and the heating effect 15.4 watts. The temperature rose one degree per hour.

Threlfall || reports a test on a paraffin-paper condenser of his own construction which had a capacity of 0.123 microfarad, and on a circuit of 3000 volts and a frequency of 60 the rise of temperature was less than one-fifth of a degree per hour. The apparent watts would be about the same as in the experiment of Bedell, Ballantyne, and Williamson, although the capacity was only one-twelfth as much. Threlfall concludes, apparently, that since his condenser had only one-twelfth the

* Communicated by the Authors.

† *Wied. Ann.* vol. 1. p. 138.

‡ *L'Eclairage Electrique*, Feb. 12, 1898.

§ 'Physical Review,' October 1893, vol. i. p. 81

|| 'Physical Review,' vol. iv. p. 458 (1897).

electric capacity, it also had only one-twelfth the capacity for heat of the other condenser; and since the temperature rose five times more slowly, therefore that the percentage loss of energy was only one-sixtieth as great, that is, $\frac{1}{60}$ of 3%, or 0.05%, giving his condenser an efficiency of 99.95%! The reasoning is, however, quite inconclusive, for nothing is said concerning the thickness of the paraffin-paper dielectric and the volume of the condenser. Suppose the dielectric of the smaller condenser to be 0.0129 inch thick, which is three times the thickness of the other. (It might have been as thick as that, seeing it sustained for a considerable period an alternating voltage of 3000.) Then the volume per unit of capacity would be nine times as great as the other, and the heat required to raise its temperature as rapidly would be nine times as great, assuming the capacity for heat and rate of radiation the same for both. The loss would then have been 0.45% instead of 0.05%. This illustrates how entirely inconclusive any determination merely of rise of temperature is, unless all such circumstances as heat capacity, rate of cooling, thickness of dielectric (or intensity of the electrostatic induction) are specified.

The enormous discrepancy between the results above referred to as to the quantity of the heating effect in condensers, and the almost entire lack of precise statements as to its numerical value, led us to undertake, more than a year ago, to measure this energy loss in such a way that it could be expressed absolutely.

We proposed to measure by means of a wattmeter the energy dissipated in a condenser when it is subjected to an alternating electromotive force. In order that the frequency of charge and discharge be perfectly definite, the electromotive force should be a simple harmonic one, that is, the upper harmonics of the fundamental should be absent. This is most easily effected by inserting in the circuit in series with the condenser a coil of wire having large self-induction, but without an iron core. The variable permeability of the iron will give rise to upper harmonics, especially if the magnetic induction of the core attains large values; and hence a coil without an iron core is necessary. Moreover, if the self-induction is not large enough it will reinforce some of the upper harmonics instead of quenching them; and the presence of the coil will be detrimental rather than beneficial. The best value of the self-induction of the coil is such that the fundamental is reinforced to a maximum degree; in other words, it is that value of L given by the equation

$$t = 2\pi \sqrt{LC},$$

where t is the period of the fundamental component of the impressed electromotive force and C the capacity of the condenser.

There is another practical advantage resulting from this arrangement, namely, that the resulting resonance raises the electromotive force at the terminals of the condenser very greatly, saving the necessity of raising the voltage by transformers. And a third advantage now appears in the fact that the wattmeter may be inserted across the low-voltage supply wires to measure the total power expended upon coil and condenser. Then subtracting the I^2r loss of the coil, the remainder will be the power expended upon the condenser. This supposes, of course, that there is no iron core and no eddy-current loss in the copper coil itself.

The Resonance Method.

Fig. 1 shows the connexions for this method with the coil in series with the condenser. M, N are the low-voltage supply-wires of an alternating circuit, S is an adjustable resistance, E is a dynamometer, F a wattmeter, R a non-inductive resistance in shunt with the coil and condenser,

Fig. 1.

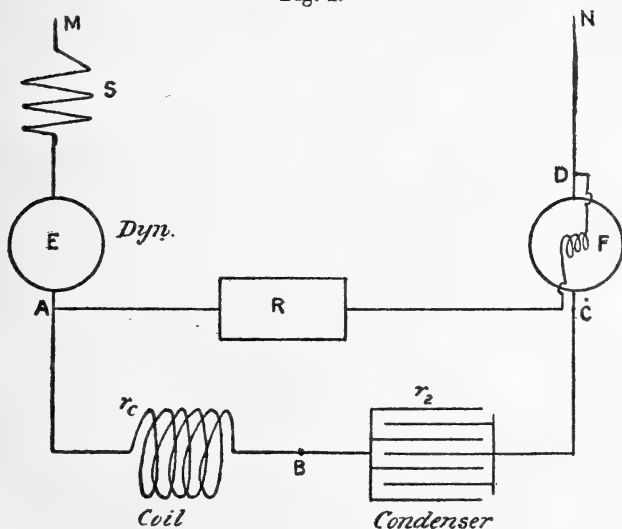

joining the points A and D . The wattmeter therefore measures the power expended between the points A and D , including the I^2r_w loss in the fixed coil of the wattmeter, but not including the i^2R loss in the shunt-resistance R . The

73625

energy expended in the resonance-coil and the fixed coil of the wattmeter, $I^2(r_c + r_w)$, subtracted from the total power measured leaves the condenser loss. This remainder is found to be also proportional to the square of the current. Hence we may write it $I^2 r_s$, and r_s is the "equivalent resistance" of the condenser, which it is desired to find. This does not indicate the nature of the process by which energy is dissipated in a condenser, but simply that for a given condenser made of a given dielectric at a given temperature and frequency, the heating effect is the same as though there were a certain resistance r_s in series with a perfect condenser of the same capacity. For the same dielectric r_s changes with changes in the temperature or the frequency; and for another dielectric with the same capacity, temperature, and frequency r_s would be different.

If $t = 2\pi\sqrt{LC}$, there is complete resonance; $t = \frac{1}{n}$, and $p = 2\pi n$. Therefore $\frac{1}{p} = \sqrt{LC}$, or $C = \frac{1}{p^2 L}$. That is, for complete resonance the capacity is inversely proportional to the square of the frequency for a given self-induction. If

Fig. 2.

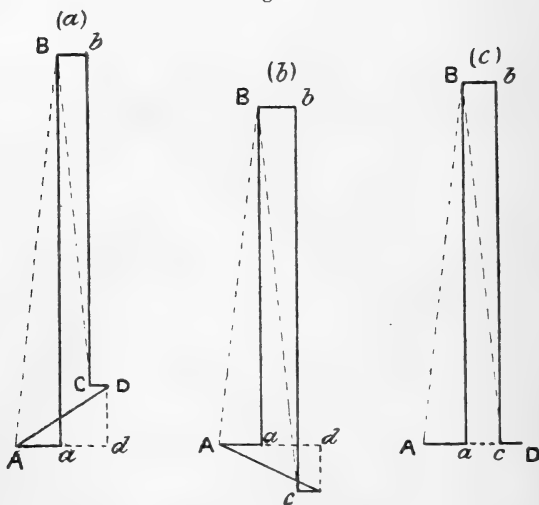

the frequency is fixed, either the capacity or the inductance may be varied until the current is a maximum; but if the frequency can be varied, the maximum resonance may be attained without varying C or L.

In fig. 2, let $Aa=r_c$, the ohmic resistance of the coil ;
 $aB=pL$, the reactance of the coil ;
 $Bb=r_s$, the equivalent resistance of the con-
 denser ;
 $bC=\frac{1}{pC}$, the condensation of the condenser ;
 $CD=r_w$, the resistance of the fixed coil of the
 wattmeter, its induction being ne-
 gligible;
 AD =the resultant impedance of the circuit.

Then if $pL=\frac{1}{Cp}$, the reactance is equal and opposite to the
 condensation (fig. 2 c), the resonance is complete, and the
 impressed electromotive force e is expended in overcoming
 the resultant resistance $AD=r_c+r_s+r_w$, and $I=\frac{e}{r_c+r_s+r_w}$.

In fig. 3, similar to fig. 2 c, the several lines represent
 electromotive forces. $Aa=Ir_c=e_c$ =that part
 of the electromotive force expended in over-
 coming the ohmic resistance of the coil ; simi-
 larly, $Bb=e_s$, $CD=e_w$. Ba is the electromo-
 tive force (due to resonance) which overcomes
 the reactance, and bC is the electromotive force
 which overcomes the condensation. The po-
 tential of the point B varies through a wide
 range; whereas the points A, C, and D, and
 the instruments suffer only small changes of
 potential.

Advantages of the Method.

Herein lies one of the chief advantages of
 the method, that voltages below a hundred
 have to be dealt with at the instruments,
 whereas upon the condenser there may be an
 active electromotive force of several thousand
 volts. The noninductive resistance R is at
 most a few hundred ohms. On the contrary, if the shunt-
 resistance were applied directly at the terminals of the con-
 denser, it would necessarily be several thousands of ohms, it
 must be capable of carrying the entire shunt-current of the
 wattmeter, it must be strictly non-inductive, and be of
 known value—conditions difficult to fulfil. In the resonance
 method a small inductance in the shunt-resistance or the
 movable coil of the wattmeter produces no appreciable error;
 whereas in the simple wattmeter method it produces a large
 error.

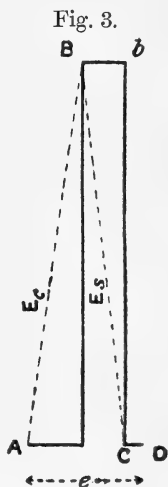

To illustrate this point let us take a special case. Suppose the resistance R is 500 ohms and the inductance of the shunt-circuit, including both the resistance R and the movable coil of the wattmeter, is 0.003 henry, $2\pi n$ being 800. Then $pL = 2.4$ and $\tan \phi_1 = 0.0048$, $\phi_1 = 16' 30''$, the angle of lag of the shunt-current behind the electromotive force. Suppose the true angle of the condenser-current, ϕ_2 (fig. 4), is $89^\circ 40'$ ahead of the electro-

Fig. 4.

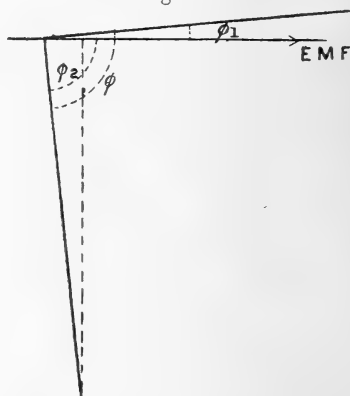

motive force. Then the difference of phase of the two currents in the wattmeter will be $\phi = \phi_1 + \phi_2 = 89^\circ 56' 30''$, and the power factor, $\cos \phi$, of the expression watts = $EI \cos \phi$ will be $\cos 89^\circ 56' 30''$ instead of $\cos 89^\circ 40'$, that is .00102 instead of .00582; thus the wattmeter would indicate that the power absorbed in the condenser was only about one-sixth of what it really is. If the lag of the shunt-current were more than $20'$ (a not improbable value in many cases), the deflexion of the wattmeter would be *negative*! It is possible that this explains why it has often been claimed that the loss in certain condensers is too small to be measured by a wattmeter. For example, Swinburne*, speaking of some of his own condensers, says "a condenser that takes 2000 volts and 10 amperes has a loss that is too low to measure—that is to say, it is less than 5 or 10 watts."

On the other hand, if by means of a resonance-coil the current and electromotive force have been brought very nearly, if not exactly, into phase, any small lag of the shunt-current will make no appreciable error. Thus, the cosine of 10° is .9848, and of $10^\circ 16' 30''$ is .9840, a difference of less than one part in a thousand.

In order to determine the precise values of r_c and r_w a Wheatstone bridge is joined to $A D$ and the condenser short-circuited, so that the resonance-coil and the fixed coil of the wattmeter and the lead-wires form the fourth arm of the bridge. The resistance is then quickly measured just after the wattmeter has been read and the alternating circuit broken, and changes due to temperature are included.

* 'Electrician,' Jan. 1 (1892).

Method of Measuring Energy dissipated in Condensers.

Difficulty of the Method.

We have seen that the presence of a resonance-coil in series with the condenser (1) quenches, to a large extent at least, the upper harmonics, (2) raises the voltage upon the condenser, thus avoiding transforming up, (3) enables measurements to be made more safely and more conveniently upon a low voltage, and (4) transfers the wattmeter problem from the most unfavourable case (where the angle of phase-difference is nearly 90°) to the most favourable case where the current and electromotive force are nearly in phase. There is, however, one serious difficulty in the method. If the resonance-coil is made of small wire, it has a great resistance, and of the total power measured only a small part is expended on the condenser. Thus the condenser loss is the difference between two relatively large quantities, and cannot be determined as accurately as would be desired. If, on the other hand, a large coil of larger wire is used so that its resistance is small, there will be eddy-currents in the copper of the coil, and the power expended on the coil will be greater than $I^2 r_c$. This excess will go into the remainder as condenser loss, and may give rise to a considerable error. If the wire is of large cross-section, but stranded, so that its resistance is small and the eddy-currents negligible, then a large coil will have a large inductance, and no difficulty appears. The method is then accurate as well as quick and convenient.

The Resonance Ratio.

As the condenser is alternately charged and discharged energy is handed to and fro between the coil and the condenser. When the condenser is charged to its maximum extent the current is zero and all the energy is potential and residing in the condenser. A quarter of a period later the condenser is discharged and the current is a maximum; the energy is now kinetic, and resides in the magnetic field of the resonance-coil. At other instants the energy is partly potential (in the condenser) and partly kinetic (in the coil). As this transfer of energy to and fro continues, the dynamo supplying the current furnishes just enough energy to make good the losses, that is, the heating effect in the wires and the dielectric of the condenser. The losses due to electromagnetic radiation and mechanical vibrations are usually negligible.

For the condenser alone,

$$I = \frac{E}{\sqrt{r_c^2 + \frac{1}{C^2 p^2}}}$$

I and E being the square root of the mean square values as indicated by an electro-dynamometer and electrometer.

For the combined circuit

$$I = \frac{e}{\sqrt{(r_w + r_c + r_s)^2 + \left(pL - \frac{1}{Cp}\right)^2}}$$

where e is the small impressed electromotive force and the denominator is the combined impedance of the circuit.

For complete resonance,

$$pL = \frac{1}{Cp}, \text{ and hence } I = \frac{e}{r_w + r_c + r_s}.$$

Hence

$$\frac{E}{e} = \frac{\sqrt{r_c^2 + \frac{1}{C^2 p^2}}}{r_c + r_s + r_w} = \frac{\text{Impedance of the condenser}}{\text{Total resistance}} = \text{Resonance ratio.}$$

In one case e was 50 volts and E was 2250, giving a resonance ratio of 45. The impedance was 51 ohms, $r_c + r_w$

was $\cdot 38$, r_s was $\cdot 72$. Hence $\frac{51}{\cdot 38 + \cdot 72} = 46\cdot 4$, agreeing very

nearly with the ratio of the voltages. In this case the coil was of large wire (No. 5 B & S), and had considerable eddy-current loss. Hence the value $\cdot 72$ for r_s was too large, and the degree of resonance was lower than it would have been in the absence of eddy-currents. In another case, using a coil of No. 10 wire, the impressed electromotive force was 29.5 volts, the voltage on the coil or the condenser was 1808, and the resonance ratio $\frac{E}{e}$ was therefore 61.9.

The Resonance-Coil in Parallel.

A second arrangement of the resonance-coil is to put it in parallel with the condenser (fig. 5), and impress upon both a high electromotive force. Each of the two parallel circuits from B to C takes its own current, independently of the other, but being nearly opposite in phase they nearly cancel each other in the supply wires. Hence a small transformer is sufficient to supply the small current needed, although without the resonance-coil a large transformer would be necessary. If, as before,

$$pL = \frac{1}{Cp},$$

there is complete resonance. The two parallel circuits having the same impedance take the same current; one current is nearly 90° ahead in phase of the electromotive force (see

Fig. 5.

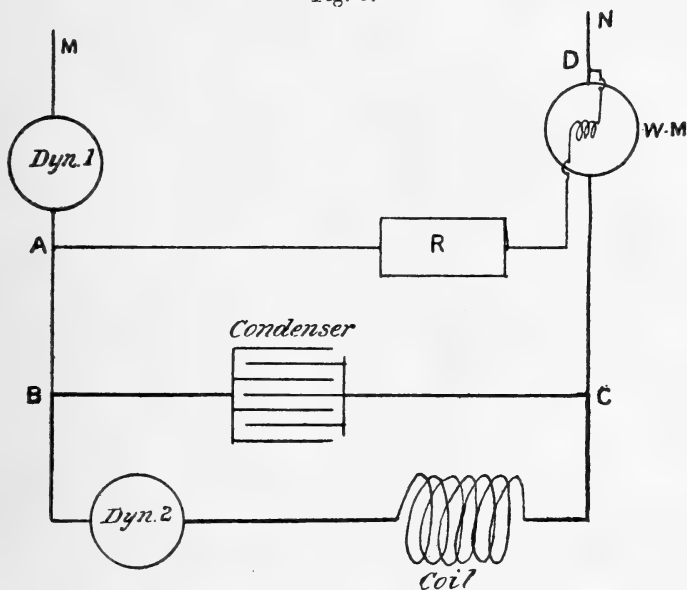

curve 2, fig. 6), the other is nearly 90° behind (curve 3), the sum of the two being relatively very small (curve 4) and in phase with the impressed electromotive force (curve 1). The shunt resistance must be applied at the high voltage terminals, but as a small amount of self-induction produces no appreciable error in the wattmeter, the movable coil may be long enough to make the wattmeter quite sensitive, and so a quite small shunt current may be used. This requires a larger resistance, but with much smaller carrying capacity, since a much smaller shunt current will suffice than when the main current differs largely in phase from the shunt current.

To illustrate this point, suppose as before that for a given condenser the angle of advance of the current is $89^\circ 40'$. The power factor, $\cos \phi$, in the expression watts = $E I \cos \phi$ is in this case .00582. If now a resonance-coil be placed in parallel with the condenser and the current in the fixed coil of the wattmeter brought into phase with the electromotive force, then $\cos \phi = 1$. To get a certain deflexion of the wattmeter, therefore, we must have the product of the two currents in the wattmeter nearly 200 times as great in the first case

Fig. 6.

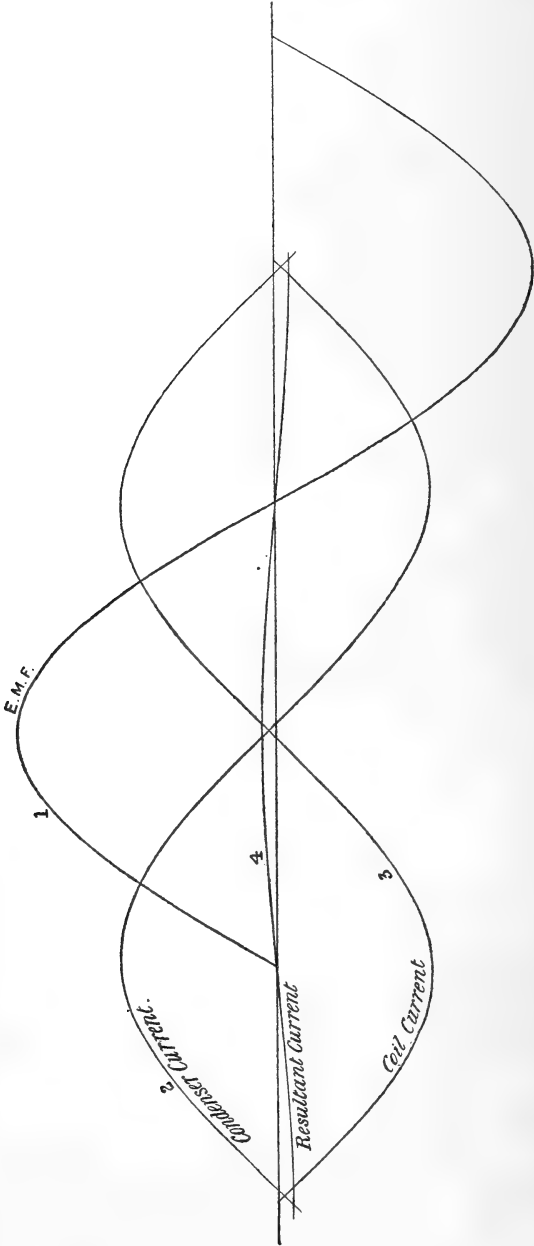

as in the second, and this requires a relatively large shunt current.

A modification of the method, if a second small transformer is available, is to transform down again to a low voltage, and put the shunt circuit of the wattmeter on the low voltage secondary of this second transformer. The current will now be almost exactly opposite in phase to the high electromotive force at the terminals of the condenser, and by interchanging the terminals the wattmeter deflexion will be the same as before, if the shunt resistance is reduced in the ratio of transformation. The currents in the two coils of the wattmeter are so nearly in phase with one another that a small change in the phase of the shunt current will produce no appreciable error.

The Efficiency of a Condenser.

Having thus determined the energy, w , dissipated in a condenser, by wattmeter measurements, we readily find r_s , the equivalent resistance of the condenser, from the expression

$$w = I^2 r_s.$$

The ratio of the equivalent resistance to $\frac{1}{Cp}$ is $\cot \phi$ (fig. 7), ϕ being the angle of advance of the current ahead of the electromotive force. It remains to calculate the efficiency of a condenser.

In fig. 8 I is the current flowing into and out of the condenser, assuming both current and electromotive force to be simply harmonic. The dotted curve is the power curve.

$$e = E_1 \sin pt,$$

where e = the instantaneous E.M.F. acting on the condenser, and E_1 is its maximum value.

$$i = \frac{E_1}{\text{Impedance}} \sin (pt + \phi) = I_1 \sin (pt + \phi).$$

$$\begin{aligned} ei &= E_1 I_1 \sin pt \sin (pt + \phi) \\ &= E_1 I_1 [\sin^2 pt \cos \phi + \sin pt \cos pt \sin \phi]. \end{aligned}$$

The area of the power curve for one half-period, that is the area of the positive loop from B to C, minus the area of the

Fig. 7.

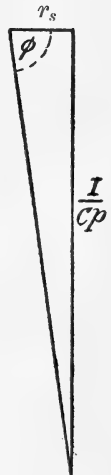
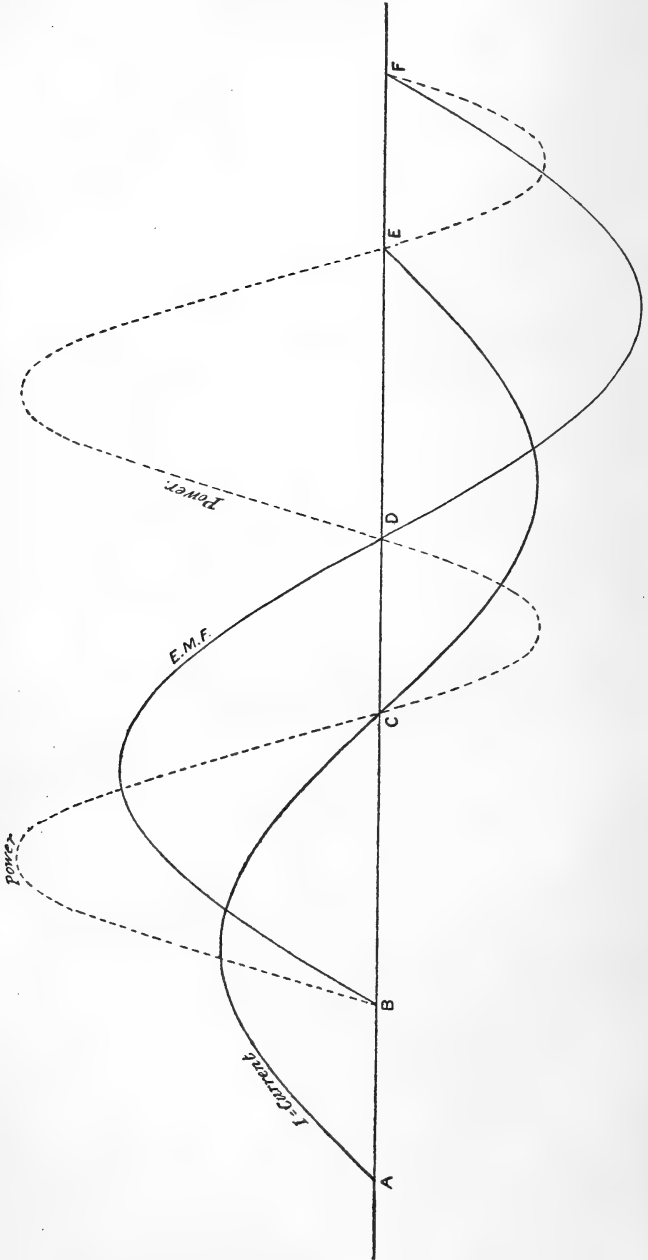

Fig. 8.



negative loop from C to D, is given by the integral

$$\begin{aligned} \int ei dt &= E_1 I_1 \cos \phi \int_0^\pi \sin^2 pt dt + E_1 I_1 \sin \phi \int_0^\pi \sin pt \cos pt dt, \\ &= \frac{E_1 I_1}{p} \cos \phi \left[\frac{pt}{2} - \frac{\sin 2pt}{4} \right]_0^\pi - \frac{E_1 I_1}{4p} \sin \phi \left[\cos 2pt \right]_0^\pi \quad (1) \\ &= \frac{1}{2} \frac{E_1 I_1}{2\pi} \cos \phi, \end{aligned}$$

and this is the work done in $\frac{1}{2n}$ of a second.

Hence for one second the work done, and therefore the power, is the well-known expression

$$\frac{1}{2} E_1 I_1 \cos \phi = EI \cos \phi \quad (E = E_1 \sqrt{\frac{1}{2}}),$$

E and I being the effective values of the electromotive force and current.

The area of the positive loop, which represents the work done upon the condenser in charging it, is

$$\int_0^{\pi-\phi} \frac{\pi-\phi}{p} eidt = \frac{E_1 I_1}{p} \cos \phi \left[\frac{pt}{2} - \frac{\sin 2pt}{4} \right]_0^{\pi-\phi} - \frac{E_1 I_1}{4p} \sin \phi \left[\cos 2pt \right]_0^{\pi-\phi},$$

and the area of the negative loop, which represents the work done by the condenser in its discharge, is the value of the same integral between the limits $\pi - \phi$, and π , for pt .

The efficiency is the ratio of the work done by the condenser in its discharge to the work done upon the condenser in charging it.

This is the *gross efficiency*, η .

Taking $\phi = 89^\circ$,	$\eta = \frac{\text{Area of the Negative loop}}{\text{Area of Positive loop}}$	$= \frac{1/p E_1 I_1 \times .48638}{1/p E_1 I_1 \times .51378}$	$= 94.67 \%$
,, $\phi = 88^\circ$,	$\eta =$	$= \frac{.47287}{.52769}$	$= 89.68 \%$
,, $\phi = 87^\circ$,	$\eta =$	$= \frac{.45684}{.53905}$	$= 84.75 \%$
,, $\phi = 45^\circ$,	$\eta =$	$=$	$= 6.38 \%$

Having found the angle ϕ by the wattmeter measurements the gross efficiency of the condenser may be found from the above equations, or taken from fig. 9, which is drawn from them.

Fig. 9.

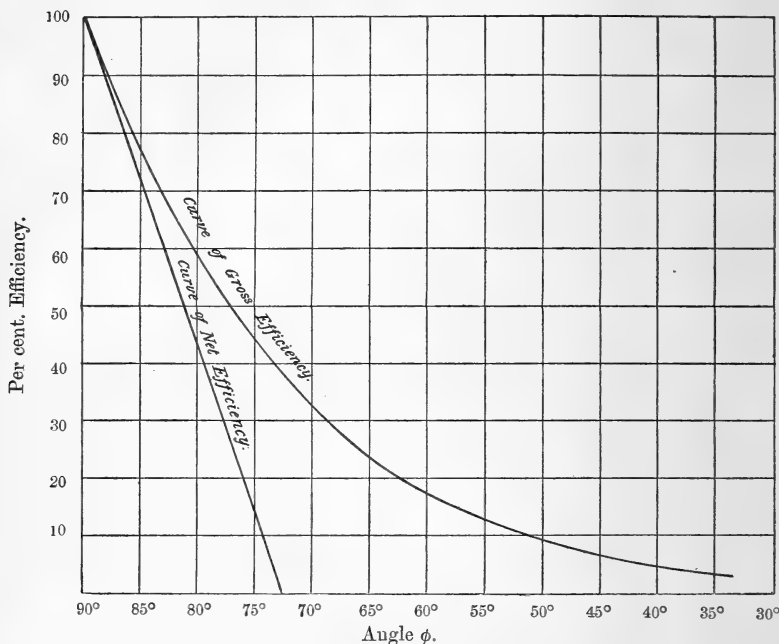

Second Definition of Efficiency.—Net Efficiency.

Regarding the condenser as an instrument for storing electrical energy, and one in which a certain amount of energy is dissipated in the process, we may define the percentage of loss as the ratio of the energy dissipated to the energy stored. The efficiency is then unity minus the loss, or, in per cent., the efficiency is 100 minus the per cent. of energy dissipated. This we may call the net efficiency, and represent it by ϵ . Then

$$\epsilon = \frac{\text{Energy Stored} - \text{Energy Dissipated}}{\text{Energy Stored}}, \text{ or } 1 - \frac{\text{Energy Dissipated}}{\text{Energy Stored}}.$$

In fig. 10,

$$I_1 r_s = E_1 \cos \phi = \text{active electromotive force};$$

$$\frac{I_1}{Cp} = E_1 \sin \phi = \text{wattless electromotive force, or the E.M.F.}$$

which charges the condenser.

The maximum charge of the condenser is

$$CE_1 \sin \phi,$$

and its energy

$$W = \frac{1}{2}CE_1^2 \sin^2 \phi.$$

The expression for the power is

$$\frac{1}{2}I_1E_1 \cos \phi.$$

But

$$I_1 = CE_1 \sin \phi \cdot p.$$

Hence the energy dissipated per second is

$$\frac{1}{2}CE_1^2 \sin \phi \cos \phi \cdot p,$$

and the energy dissipated per half-period (that is during the time of a single charge and discharge) is

$$w = \frac{1}{2}CE_1^2 \sin \phi \cos \phi \cdot \pi.$$

The relative loss is therefore

$$\frac{w}{W} = \pi \cot \phi,$$

and the net efficiency is

$$\epsilon = 1 - \pi \cot \phi.$$

For

$$\phi = 89^\circ, \epsilon = 94.52 \%,$$

$$\phi = 88^\circ, \epsilon = 89.03 \%,$$

$$\phi = 87^\circ, \epsilon = 83.54 \%,$$

$$\phi = 72^\circ 20' 30'', \epsilon = 0.$$

The net efficiency, ϵ , is therefore slightly less than the gross efficiency, η , for values of ϕ nearly 90° ; but, as the angle ϕ diminishes, ϵ falls rapidly below η , and for $\phi = 72^\circ 20' 30''$ the energy dissipated is equal to the energy stored, and the net efficiency is therefore zero, while the gross efficiency is about 38 per cent. For greater angles of lag the loss is greater than the maximum energy stored, and ϵ becomes negative (see fig. 9).

For ordinary cases the angle ϕ is greater than 88° , and ϵ and η are nearly equal. Since the wattmeter method gives directly the value of ϕ it is much easier to express the value of the net efficiency ϵ (namely, $1 - \pi \cot \phi$) than the value of η . For small values of $\cot \phi$ this is sufficiently exact to write it $\epsilon = 1 - \pi \cos \phi$.

Suppose that instead of assuming the effective resistance r_s of the condenser to be in series with the condenser, as we have done in figs. 2, 3, 7, and 10, we consider that it is in

Fig. 10.

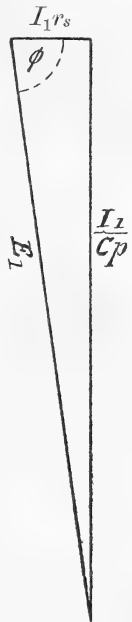

parallel, as in fig. 11. Of course there is a slight leakage current in every case, if the resistance of the dielectric is not infinite. Boucherot* says of his paraffin-paper condensers

Fig. 11.

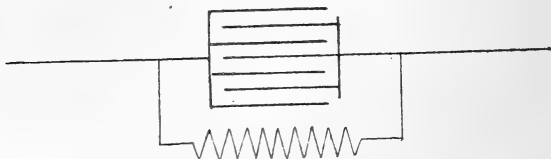

that the "heating is chiefly due to the Joule effect, that is, to leakage current; the action of dielectric hysteresis, if it exists at all, being very slight." We shall give reasons in a subsequent paper for believing that this is seldom, if ever, true of good condensers, but at present let us assume it to be true. Then the condenser current is 90° ahead of, and the leakage current in phase with, the impressed electromotive force. I being the total current, the condenser current is $I \sin \phi$ and the leakage current is $I \cos \phi$. The energy stored is

$$W = \frac{1}{2} C E_1^2,$$

and the energy dissipated per second is

$$\frac{1}{2} E_1 I_1 \cos \phi,$$

or per half-period

$$w = \frac{1}{4n} E_1 I_1 \cos \phi.$$

The maximum condenser current, $I_1 \sin \phi$, $= p C E_1$.

$$\therefore w = \frac{E_1^2 \cdot p C \cos \phi}{4n \cdot \sin \phi} = \frac{1}{2} C E_1^2 \pi \cot \phi.$$

$$\therefore \epsilon = 1 - \frac{w}{W} = 1 - \pi \cot \phi, \quad \text{as before.}$$

Referring to fig. 13, we can derive anew the value of the net efficiency. Curve 1 is the electromotive force, curve 2 is the current, in advance in phase by the angle ϕ , nearly 90° ; curve 3 is the power, the positive and larger loop being the work done on the condenser, and the negative and smaller

Fig. 12.

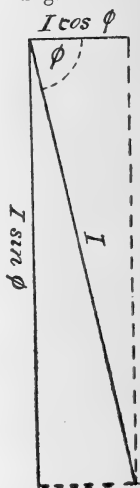

* *L'Eclairage Electrique*, Feb. 12, 1898.

Fig. 13.

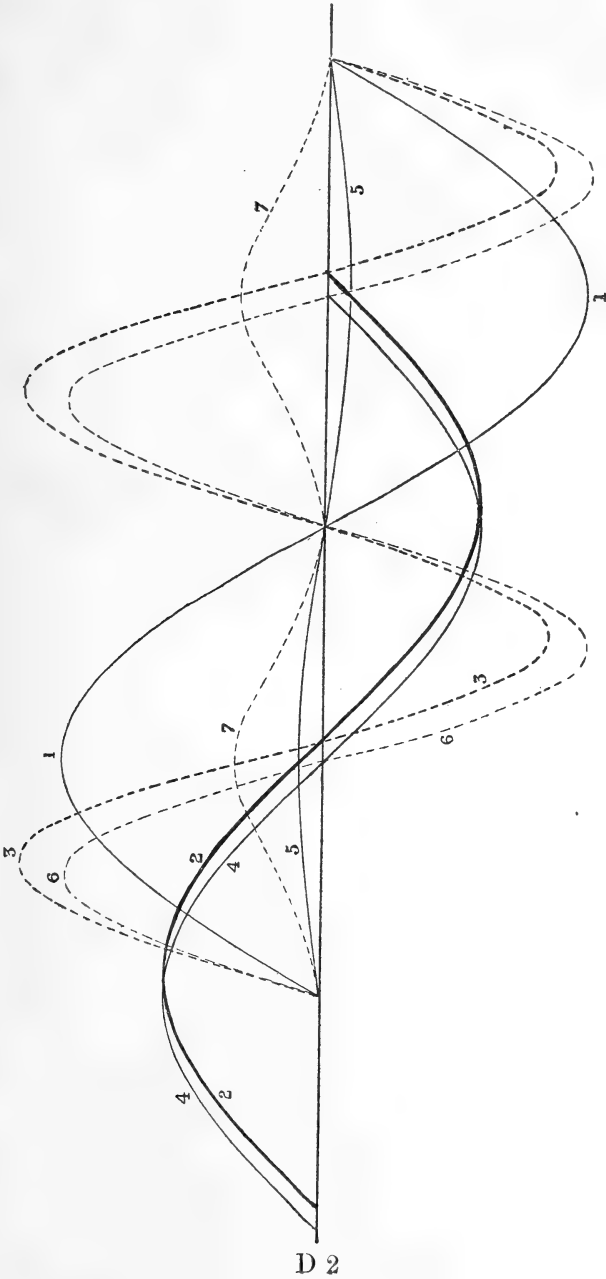

loop being the work done by the condenser upon its discharge. Equation (1), p. 31, shows the area of this power-curve to consist of two terms, the coefficient of one containing $I \cos \phi$ and of the other $I \sin \phi$. Now $I \cos \phi$ is the component of the total current which is in phase with the E.M.F., and is represented by curve 5. $I \sin \phi$ is the condenser current, 90° ahead of the E.M.F., and is represented by curve 4. The power-curve for 4 is 6; its positive and negative loops are equal, and it is the power-curve for a perfect condenser. The power-curve for 5 is 7, and is the total work done, or the energy dissipated. One loop of 6 is energy stored, W , one loop of 7 is energy dissipated, w , and the ratio $\frac{w}{W}$ is the relative loss, or $1 - \frac{w}{W}$ is the net efficiency.

The area of one loop of 7 is

$$w = \frac{E_1 I_1 \cos \phi}{p} \left[\frac{pt}{2} - \frac{\sin 2pt}{4} \right]_0^\pi = \frac{E_1 I_1 \cos \phi \pi}{p} = \text{Energy Dissipated.}$$

The area of one loop of 6 is

$$W = \frac{E_1 I_1 \sin \phi}{4p} \left[\cos 2pt \right]_0^{\frac{\pi}{2} \text{ for } pt} = \frac{E_1 I_1 \sin \phi}{4p} \cdot 2 = \text{Energy Stored.}$$

$$\therefore \epsilon = 1 - \frac{w}{W} = 1 - \pi \cot \phi, \quad \text{as before.}$$

If the equivalent resistance of the condenser is taken to be a series resistance then we have $E \cos \phi$ for the active E.M.F., $E \sin \phi$ for the condenser E.M.F., and the same result follows.

Example of the Resonance Method.

The condenser used was one which we had made ourselves, and consisted of paraffined paper and tinfoil. The paper was 12×17 centim. and $\cdot 0038$ centim. thick; the tinfoil was $\cdot 0025$ centim. thick, and its effective area was 10×15 centim. approximately. The paper and tinfoil were piled up dry and clamped between brass plates. It was then placed in melted paraffin and maintained for some hours at 100° to 150° C. This condenser then had a volume of about 300 cub. centim. and a capacity of about $\cdot 8$ microfarad.

The resonance-coil consisted of 3000 metres of No. 10 wire (B and S gauge, $\cdot 259$ centim. diameter) wound into a coil of 40 centim. internal diameter, 56 centim. external diameter, and 17 centim. axial length. Its resistance was about 10 ohms and its inductance 1.60 henrys. This coil was wound in ten

sections, so that by choosing different sections or combinations of sections, a wide range of inductance could be secured. In this particular case the entire coil was used. The frequency of the alternating electromotive force was varied by varying the speed of the generator, complete resonance being attained at a speed of 2175, for which the frequency is 145. The current was 1.20 amperes, the resistance $r_c + r_w$ was 9.82 ohms, $I^2(r_c + r_w) = 14.15$ watts. The wattmeter gave a deflexion of 188, corresponding to 37.6 watts. This leaves 23.45 watts for condenser loss, or $EI \cos \phi$.

E being 1808, $I = 1.20$, $EI = 2169$, and $\cos \phi = \frac{23.45}{2169} = .0108$;

$$\pi \cot \phi = 3.39 \text{ per cent.}, \quad \epsilon = 96.61 \text{ per cent.}$$

The quantity of the eddy-current loss in the coil does not of course appear. From subsequent experiments we became satisfied that it was large enough to cause a serious error in the above value of the condenser loss. Hence we shall not give any of the other values found using this coil. The results obtained over a range of from 400 to 2250 volts showed that the loss is sensibly proportional to the square of the electromotive force. This conclusion is not seriously affected by the presence of eddy-currents, since the latter are themselves proportional to the square of the E.M.F. and yet are not large enough to swamp the condenser loss.

We therefore wound up a coil of nearly 2000 metres No. 14 wire (B and S gauge, diam. .160 centim.), in 41 layers of 45 turns each, external diameter of the coil being 37 centim. The eddy-current loss in this coil is less, owing to the smaller diameter of the wire and the smaller quantity; a subsequent measurement by an independent method gave 3.2 per cent. as the increase of the effective resistance by the eddy-currents at a frequency of 120. At a lower frequency it would, of course, be less. Its use will therefore illustrate the method and give a fairly accurate value of the condenser efficiency.

Measurements on Beeswax and Rosin Condensers.

We give below a series of measurements on the efficiency of a set of commercial condensers made of tinfoil and paper, the latter being saturated with melted beeswax and rosin. We understand that they are piled up dry, as we have done with condensers made in our laboratory, and while immersed in the melted beeswax and rosin placed in a receiver from which the air is exhausted, to free them from air and moisture. With the details of the process we are not, however,

Table of Measurements on Beeswax and Rosin Condensers.

a.	b.	c.	d.	e.	f.	g.	h.	i.	j.	k.	l.	m.
	Temperature of the Condenser.	Current through the Coil and Condenser = I.	Resistance of Coil and Wattmeter = $r_c + r_w$ (ohms).	$I^2(r_c + r_w) = W_1$ (watts).	Wattmeter Readings.	Total energy in Watts. W.	Watts in Condenser. $W_2 = W - W_1$.	Voltage on Condenser, E.	Apparent Watts, EL.	$\cos \phi = W_2/EL$.	Per cent. loss = $100\pi \cot \phi$.	Net Efficiency in per cent. = $100(1 - \pi \cot \phi)$.
1	30	1.53	17.18	40.20	129½	66.70	26.50	910	1392	.0190	6.0	94.0
2	36	1.16	17.92	24.10	90	46.35	22.25	669.5	776.5	.0287	9.0	91.0
3	39	1.34	17.96	32.22	122	62.83	30.61	752	1007	.0304	9.5	90.5
4	39	1.27	17.96	28.97	108	55.62	26.65	712	904	.0295	9.3	90.7
5	47	1.31	18.22	31.26	108	55.62	24.36	731	958	.0253	8.0	92.0
6	49½	1.50	18.42	41.44	131	67.46	26.02	839	1259	.0207	6.5	93.5
7	59	0.80	18.34	11.74	173	89.10	77.36	433	346	.2230	72.0	28.0

acquainted, and cannot say whether it is something in the method of manufacture or the nature of the dielectric which makes the dissipation of energy so large; we presume, however, that it is the latter. There were six condensers joined together, each being a solid slab of about 11 centim. \times 15 centim. \times 1.5 centim., thus having a volume of about 250 cub. centim., and a capacity of one third of a microfarad.

The six slabs were placed on a table, joined together in parallel, and in series with the resonance-coil (which was at a distance from them and from the measuring instruments), loosely covered with a woollen cloth, and coil and condenser subjected to an alternating electromotive force of about 50 volts, and a frequency of 120. No effort was made to secure the maximum degree of resonance, and the voltage on the condensers was found to be about 900. In a short time the temperature of the condensers had risen to 30°, as indicated by a thermometer inserted between two of them, and the first set of readings was taken. The loss of energy in the condensers was greater than it had been at lower temperatures, and continued to increase as the temperature rose.

At the same time, owing to this increase in the equivalent resistance of the condenser, the resonance ratio decreased and the current and voltage on the condenser decreased. The loss at 36° C. is 50 per cent. greater than at 30° C., and is approaching a maximum. At 39° it is 9.5 per cent., and the fourth reading at sensibly the same temperature (but which doubtless was a little higher, at least in some of the condensers) showed a slightly less loss. At 47° C. the loss had decreased to 8.0 per cent., and at 49° 5 C. to 6.5 per cent., only two-thirds its maximum value. The condensers were not all at the same temperature, and the indicated temperatures are therefore not exact. But they show unmistakably a maximum value of the condenser loss, or energy converted into heat, at about 39° C., and beyond that a very considerable diminution. No further readings were taken until the condensers had risen several degrees, when it was suddenly noticed that one pair was hotter than the others and getting soft. The thermometer in a cooler pair registered 59°, but the warmest pair was considerably higher. The loss was astonishingly large, but the condenser had not broken down. Moreover, the "leakage current" had not greatly increased, for while 839 volts gave 1.50 amperes at 49° 5, 433 volts gave .80 ampere at 59° C. To be in exact proportion to the voltage the current should have been .774 instead of .80 at the higher temperature, a comparatively small difference.

To find so large a loss in commercial condensers of good

reputé was a surprise to us. To find a well marked maximum as the temperature rose, beyond which the loss decreased as the beeswax and rosin composition softened was a second surprise. To find so large a loss as the last observation shows without the condensers giving way, and without any very large leakage current, was a third surprise.

In order therefore to verify these results by a totally different method, and to determine as accurately as possible the losses in some paraffin-paper condensers which we possessed which showed relatively very small heating effects, we built a special form of calorimeter, into which the condensers could be placed and the heat directly measured. The calorimeter was copied after the large respiration calorimeter which one of us designed for experiments under the patronage of the U.S. Government, and which is located at Wesleyan University. The description of the calorimeter and the results obtained with it are reserved for a subsequent communication. We will only add that they fully confirm the unexpected results obtained by the resonance method given above concerning the dissipation of energy in beeswax and rosin condensers.

Wesleyan University,
Middletown, Conn., July 1, 1898.

III. *Experiments with the Brush Discharge.*

By E. H. COOK, D.Sc. (Lond.), Clifton Laboratory, Bristol*.

[Plate I.]

THE ordinary phenomena which accompany the brush-discharge are well-known, but in view of the recent extension of our knowledge of electric discharges in high vacua, it seemed desirable to study the subject a little more closely. The following experiments have been made with this object.

Most of the results have been obtained with an ordinary Wimshurst machine with 15-inch plates, but they have also been produced with the discharge from an induction-coil, as well as, though less readily, with a plate frictional machine.

In experiments requiring the production of the brush for a short period the machine was turned by hand, but where a long-continued effect was desired, motion was obtained by the use of one of Henrici's hot-air motors. The number of revolutions of the plates was counted by means of a tachometer, and the number of volts was taken as being about equal

* Communicated by the Author, having been read before the British Association at Bristol, 1898.

to what would be produced by the same speed of rotation between knobs of one centimetre diameter. (See Joubert, Foster and Atkinson, 'Electricity and Magnetism,' p. 103.)

In all cases the results have been produced at ordinary atmospheric temperatures and pressures, but, of course, the brilliancy of the effects varies with the climatic conditions. For this reason no attempts have been made to measure the size of the brush, because it differs so much from day to day. The experiments described can be reproduced under varying conditions, and the effects may therefore be regarded as normal accompaniments of this kind of discharge.

1. *Shape of the Brush-Discharge.*

As is well known, if a discharge of negative electricity takes place from a pointed conductor, and if the point be examined in a darkened room, it will be seen that it is surrounded by a faint spot of light of a violet or violet-blue colour. If, on the contrary, a similar experiment be made with positive electricity, the point will be seen to be surrounded by an innumerable number of lines of light of a similar violet-blue colour, forming what is called the brush. It is stated, on the authority of Faraday, that the glow which surrounds the negative point is separated from it by a dark space. Undoubtedly this is the case when the discharge is taken in rarefied air, but at the ordinary pressures I have been unable to detect it, although the brush has been examined under the microscope. The glow seems to be in contact with the point. The positive discharge, however, behaves differently. When carefully observed it is seen that the lines do not start from the exact end but at some slight distance away (2 or 3 millims.). They appear to keep in a bunch for a little distance and then to diverge. The size of the positive brush is much increased by the proximity of an earth-connected plate or sphere, and the outline of the luminous portion is altered by the shape and nearness of this "earth." Thus, when an "earth" is some distance away, the emanation from a point may take the shape of a fan with the side lines at right angles to the point as in the figure. If to such a brush an "earth" be brought to within a few centimetres, the lines will curve themselves round and the angle of the fan instead of being 180 degrees will become much less. The glow at a point giving negative electricity becomes brighter if an earth-connected body be brought near, but it does not alter in size until the body is very close (less than a centimetre), when small sparks pass between the point and the body.

The angle of the point makes a considerable difference to the shape of the positive fan. If the end consists of a small angle, for example a needle, the bounding lines of the fan enclose a small angle, and the whole of the luminous portion

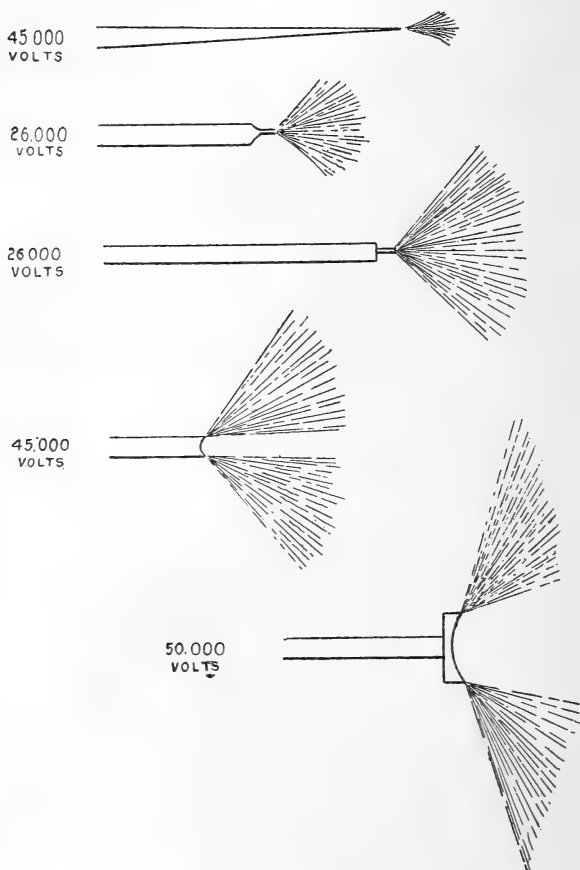

is very small. As the angle increases so does also the angle of the fan. The figures show the kinds of discharge obtained from brass points of varying angles. They were obtained from the positive side of a machine, and under similar conditions of proximity to earth-connected plates. The discharges are drawn of about actual size, but the wires and points are drawn larger than they were for the sake of clearness. The approximate differences of potential between the knobs of the machine when giving these discharges are

stated. The appearance of the discharge obtained from concave ends is also shown. Concave terminals behave like angular ones.

2. Force of Wind from Points.

The mechanical force exerted by the strongly electrified air-particles which are repelled from the points is well known, and the experiment of blowing out a candle is one of the commonest shown as illustrating the action of points. The magnitude of the force was roughly measured by causing the discharge to play upon one pan of a delicate Robervahl balance and measuring the weight necessary to restore the equilibrium. Care was taken to use the same point and to change the polarity by reversing the machine. This was the only way in which comparative experiments were possible. If the attempt be made to measure from two different points it will be found that the minute differences in the points, notwithstanding every care to make them precisely similar, will show themselves by entirely altering the appearance of the brush, and great differences in magnitude will be observed, even with the same kind of electricity, from the different brushes.

In order that vibration might be avoided as far as possible, the measurements were made on a stone slab, built up from the foundations of the laboratory. The following results were obtained :—

Wimshurst machine	15 in. plate.
No. of sectors on each plate . . .	16.
Size of sectors	8 sq. cm.
(1) Speed of revolution	450 per minute.
Potential-difference corresponding to this speed, about	43,000 volts.
Force from positive brush equal to a weight of 0.29 gramme.	
Force from negative brush equal to a weight of 0.24 gramme.	
(2) Speed of revolution	182 per minute.
Potential-difference	35,000 volts.
Force from positive brush equal to a weight of 0.08 gramme.	
Force from negative brush equal to a weight of 0.066 gramme.	
The best distance of brush from pan of balance 0.04 metre.	

Induction-Coil :—

Length of primary wire . . .	200 feet (500 turns).
Length of secondary wire . . .	60,000 feet (490,000 turns).
Capacity of condenser . . .	2 microfarads.
Length of spark in air . . .	0·07 metre.

Corresponding to

- * Potential-difference of about . . . 63,000 volts.
- Force from positive brush equal to a weight of 0·01 gramme.
- Force from negative brush equal to a weight of 0·01 gramme.

It will thus be seen that the magnitude of the force is greater from the positive side of the machine than from the negative.

An attempt was now made to find the maximum distance at which this mechanical disturbance could make itself felt. For this purpose the following experiment was arranged. A single fibre of unspun silk was stretched across the field of view of the microscope, and on this was hung a little paper index which was blown aside by the wind from the point. The maximum distance at which any deflexion could be observed was then noted, and in this way a comparison was instituted. Care was again taken not to use different points, but to alter the polarity by reversing the machine. Also, during the experiment, the whole apparatus was carefully protected from extraneous currents of air. It was found that with the machine with a potential-difference of 33,000 volts the positive brush produced an effect at a distance of 0·6 metre, the negative at a distance of 0·48 metre. When the potential difference had fallen to about 25,000 volts the distances observed were for the positive 0·32 metre, and for the negative 0·28 metre. With the coil giving a spark of 4 centimetres (41,500 volts) the positive brush affected the thread at a distance of 0·32 metre, and the negative moved it at the same distance.

These results therefore confirm the former ; for the positive brush affected the silk at the greater distance, and also produced the greater pressure upon the pan of the balance. But they show how very *quickly a moving* electrified particle of air is brought to rest by surrounding air.

* These details are given in order that an idea may be formed of the kind of apparatus worked with, and that if any one should desire to repeat the experiments he may know what results to expect. The actual numbers will vary with the apparatus.

3. *Electrical Action at a Distance.*

If an electroscope or a leyden-jar be placed at some distance from a point from which a brush-discharge is taking place, it will become charged. If the brush be a positive one the electroscope or jar will be charged positively; if the brush be a negative one it will be charged negatively.

The distances at which the effects make themselves evident vary with the potential and the atmospheric conditions. Statements of lengths therefore are only valuable as allowing of comparison being made between experiments which are performed at the same time and in the same laboratory. The same relation will, of course, hold, but the actual measurements will be different. With these reservations the following are given:—

With the plates of the machine revolving at the rate of 450 revolutions, and giving a difference of potential of about 43,000 volts, an electroscope was affected at a distance of 1·8 metres from the point. No difference was made by altering the polarity.

When the plates were revolving at the rate of 105 revolutions, and the potential-difference was 25,000 volts, the same electroscope was affected at a distance of 1·0 metre.

The size of the collecting-plate of the electroscope makes a considerable difference in the ability of the instrument to become charged. The larger this plate the greater the distance at which it can be charged. A point on the plate reduces the distance somewhat, probably because it allows the electricity to escape as fast as it can be collected.

No increased effect could be obtained by increasing the condensation.

The shape of the point which gives the best results is acute. This is different from the effect in producing luminosity. In that case it will be seen that a larger luminous brush is obtained with a greater angle up to 90°.

Notwithstanding the enormously greater difference of potential produced, the brushes from the coil used were quite unable to influence the electroscope at distances equal to those obtained from the machine. Thus, when the coil was giving sparks of 0·07 metre in length and thus causing a potential-difference of about 63,000 volts, the positive brush was only capable of charging the electroscope at a distance of 0·62 metre and the negative at the same distance.

The same relative results were obtained when the brushes were used for charging a leyden-jar. Thus, with a difference of potential of about 40,000 volts, a jar was charged by the

positive brush from the machine at a distance of 0·55 metre. The negative brush charged it negatively at the same distance. With a concave terminal this distance was reduced to 0·50 metre.

With the coil giving a spark of about 0·7 metre (63,000 volts) the jar was charged at a distance of only 0·14 metre.

But, as has been already stated, these distances vary greatly. With favourable atmospheric conditions, and a plate on the electroscope 16 by 23 centims., it was found that the electroscope could be readily affected at a distance of 4 metres from the point attached to the 15-inch Wimshurst machine. On comparing these distances with those obtained when measuring the mechanical force of the wind from the point, it is seen that the electrical effects are felt at a much greater distance, amounting, if we take the maximum distances, to more than six times.

It is not at all necessary that the conductor ending in the point should be directed towards the electroscope. The instrument will be found to be influenced in almost any position; in fact, when experimenting in frosty weather, I have obtained results at equal distances all round the point, even in the exactly opposite direction. It is therefore clear that the point is the centre of a disturbance which radiates from it in all directions.

The interposition of objects between the point and the electroscope gives interesting results. A wire-cage, if completely covering the instrument and earth-connected, will prevent it from being charged, but if it is not completely covered, even if only one side of the base is tilted up, the instrument will become charged. The same wire-cage held between the point and electroscope has no effect. Plates of metal, wood, or other material placed between, do not alter the effect *unless* they are either *close up* to the point or to the electroscope. In both cases a diminished effect is observed.

Experiments were tried with the view of discovering if the effects could be produced through substances; *i. e.* if like the Röntgen rays the brush-discharges possessed any penetrative power. Although by this mode of experimenting definite proof could not be obtained, several of the results are instructive. Thus, if the electroscope be placed at from 2 to 3 metres away from the point, and a board 56 by 78 by 15 centims. be interposed midway in the path of the discharge, the leaves are easily affected, almost as easily as if the board were absent. The same thing happens if sheets of metals are interposed. The direction of the point does not affect the result. If the sheet be placed *within* 30 centims. of the *point*, the effect on

the leaves is not produced. If the sheet be placed near to the *electroscope* (*within 10 centims.*) no effect is produced on the leaves, but as the distance is increased the leaves diverge more and more; thus at 50 centims. the effect is nearly as much as when the board is midway. It is impossible while witnessing these experiments to avoid calling to mind the similarity of the effects produced to those which one sees on the coast when a long billow rushing onwards towards the shore meets with a solitary rock in its path. The rock is grasped on all sides, but while immediately behind it the water is comparatively still, the waves soon curl as it were round the sides and meet each other at a short distance behind. The result being that the effect of the rock is to interfere with the wave for only a short distance immediately behind it. Beyond that there is as much commotion in the line from the middle of the rock to the shore as at the edges.

If while the electroscope leaves are diverged and the machine working, a person walks between the point and the instrument, the leaves will sway with his movements, but will not fall together.

The production of the effect all round the point extends to positions under the machine, for I have repeatedly obtained the divergence of the leaves when the electroscope was placed directly *under* the machine, which stood on an inch board on the bench, which had a two-inch top.

4. *Chemical Action produced by the Brush-Discharge.*

The formation of ozone by the working of an ordinary electrical machine is well known, but whether positive or negative is more active in its production has not been investigated. It was therefore determined to examine the action of the brush-discharge in producing this and other chemical changes. The whole of the work contemplated has not been completed, but some results of interest may be mentioned. Considerable difficulty was experienced, in consequence of the high potentials used, in preventing leakage. In some cases leakage took the form of brushes at other places than the points required. In such cases the results were useless. In consequence of this, whenever it was necessary to lead the brush away from the point only the most strongly insulated wire was used, and this was first specially examined in order to see if any cracks or thin places were in it. Whenever the wire had to be led into flasks or bottles it was found that the best material for bungs was solid paraffin. But it was found very difficult to produce good brushes inside glass vessels, because the interior surface

very soon became rapidly charged, and this seemed to prevent the production of the brush.

Experiments with Potassium Iodide.

The chemical action produced by the brushes in air may be the formation of ozone, the production of oxides of nitrogen, and perhaps other less known combinations. Potassic iodide would be decomposed by ozone and the oxides of nitrogen, and it is therefore a suitable substance to experiment with. After many trials the simplest apparatus was found to be the most useful. The points attached to the positive and negative sides of the machine were placed at such a distance above the surface of some standard potassic iodide solution that no actual spark from the point could pass to the solution (with the machine and potential used, this was anything beyond 2 centim.). This precaution was taken in order that no breaking up of the iodide should take place in consequence of the spark passing through it. The solution was contained in glass or porcelain dishes, and as solution of potassic iodide (unless perfectly pure) becomes slightly coloured when exposed for some time to air and light, a similar quantity of the standard solution was placed in an extra dish of equal size at the same time. At the conclusion of the experiment the amount of iodine set free from this blank was estimated and subtracted from that produced under the brushes.

The results obtained have differed among themselves as far as actual amounts of iodine set free at one brush compared to the amount set free at the other, but they have all agreed in this important particular, that the *amount of iodine produced by the negative brush from the machine is always very much greater than the amount produced by the positive in the same time.*

With points prepared as similarly as possible, and every precaution taken to avoid leakage, it was found that from *five to eight* times as much iodine was set free by the negative brush as by the positive. The following are details of a typical experiment:—

Speed of rotation of plates of machine, 300 per minute.

Potential-difference about 40,000 volts.

Distance of points from surface of solution, 4 centims.

Amount of iodine liberated by the negative brush over that in blank in half-hour, 0·000762 gramme.

Amount of iodine liberated by the positive brush over that in blank in half-hour, 0·000127 gramme.

The greatest amount of iodine liberated in one hour in this way amounted to 0·001778 gramme; assuming this to be

produced by the formation of ozone, which then decomposes the iodide, it would correspond to the formation of 0.000112 gramme of ozone.

Condensing the electricity produces very little effect. For with the jars on, similar results have been obtained to those without the jars. Thus with points 4 centims. away and a potential-difference of about 40,000 volts, 0.001778 gramme of iodine was produced at the negative brush, and 0.000190 gramme at the positive in one hour.

A diminution of potential-difference reduces the amount of chemical action; but the substance of which the point is composed is immaterial. Thus, with 25,000 volts difference, 0.000698 gramme of iodine was set free by the negative in half an hour, as against 0.000762 gramme with 40,000 in the same time.

The distance of the point from the surface of the liquid makes an important difference. It has already been stated that all the experiments were made when the points were farther away than that at which a spark could pass. The best effects are caused when the points are *just* farther away than this. Thus when the points were 12 centims. away 0.000021 gramme was liberated by the negative, as against 0.000063 gramme when 8 centims. away, and 0.000508 gramme when 4 centims. away.

Similar experiments to the above made with the brushes obtained with the coil have given different results. In this case it was found *that invariably the brush from the positive terminal liberates the greater amount of iodine*. The difference between the amounts produced by the positive and negative brushes is not, however, so great as that by the machine. In this case also we find differences between individual experiments, but as before always an excess by the same pole. The average of many experiments gave from three to five times as much iodine set free under the positive brush to that set free under the negative. These numerical results apply to the coil whose dimensions are given above.

It was found that with the machine and coil as described, a much greater quantity of decomposition was caused by brushes from the machine than from the coil. This corresponds to the amount of *visible* brush produced.

Action on other Substances.

The power of the brushes to produce other chemical actions has been partially investigated. So far no reducing actions have been observed, but oxidizing ones are always present. In these cases with the machine brushes more action

takes place at the negative than at the positive, and generally the same conditions apply as in the case of potassic iodide. Thus about *four* times as much iron is oxidized from the ferrous to the ferric condition by the negative as by the positive brush.

5. *Effect on the Electrodes.*

It is stated* on the authority of Wheatstone that:—“Metallic dust is in every case torn away from the electrode by the brush discharge.” This statement is one which would be supposed to be true when it is considered that such is known to be the case with the spark-discharge. But it is contradicted by spectroscopic evidence, for the spectrum of the glow-discharge shows no trace of metallic lines. It is the same “whatever the nature of the metal, and is due solely to the incandescent gas.”† In order to test the statement several experiments were made. The brushes were obtained from copper points, and made to play upon the surface of some dilute nitric acid placed in dishes under them. The points were brought as near as possible to the surface, *i. e.* as near as possible without producing a spark-discharge. They were so near that minute waves were formed during the whole time of the experiment by the wind from the points. No possible loss of copper could therefore occur if any were torn off from the point. The machine was run at its highest speed, and thus the greatest difference of potential available (from 40,000 to 50,000 volts) was obtained. The experiment was continued for two hours, during the whole of which time very fine luminous brushes were being produced at each point. At the conclusion of the experiment the acid was carefully concentrated by evaporation and tested for copper. Not a trace could be found in either. Thus showing *that no metallic particles were torn off the points.* Moreover, I have examined microscopically a pair of points which I had cut and prepared from a piece of guttapercha-covered wire. These points have been continuously in use for some months, and it is certain that at a low computation brushes must have been drawn from them for at least 150 hours. The edges seem as sharp as when cut, and sensible alteration has not taken place in them.

Of course these results apply to the potential and quantity worked with. Higher potential and increased quantity may give quite different results.

* Silvanus Thompson's 'Elementary Lessons,' p. 305.

† Joubert, Foster and Atkinson, 'Electricity,' p. 103.

6. *Action of the Brush-Discharge upon Photographic Plates.*

The productions of chemical actions by the brush-discharges immediately gave one the desire to try the action upon photographic plates. The first experiments of this kind were made shortly after the discovery by Röntgen; but as they did not lead to any results which were of such general interest as the latter, the study was discontinued for a time but taken up again recently.

In these experiments, as in the former, the brush from the machine gives better results than that from the coil, but the positive seems to be more effective than the negative. In the latter case a longer exposure is necessary, and sometimes less definite results are obtained. Films of different kinds were used, but because of the greater ease in development, ordinary "slow" plates were most frequently employed ("Ilford Ordinary").

Action of Brush-Discharge upon a Sensitive Film.

If a photographic plate be placed on the table in a dark room with the uncovered film upwards, while the positive or negative brush from a machine or coil be arranged at some distance (say 4 feet) above it and the point turned towards it; the plate after development will be found to be "fogged," showing that a decomposition of the silver salts has been brought about, similar to that produced by exposure to light. With the brush from the positive terminal the reduction of the silver compound is fairly uniform all over the plate, but when the negative is used there are "blotches" in several places, showing that the reducing action has taken place in some spots more than in others. There is therefore produced at the point an emanation of some kind, whether it be an undulatory movement or a stream of particles, which possesses the power of reducing silver salts.

If between the point and the sensitive film a solid object be placed, a shadow of the object will be thrown upon the plate. This shadow is sharp if the object is close to the plate, but its edges are ill-defined if it be at some distance from it, in this particular exactly resembling light. Pl. I. (figs. 1 and 2) shows this, the object being a piece of sheet-zinc cut into the shape of the letter H and placed firstly at 1.5 centim. away from the plate, and secondly at 10 centims., the point being about 30 centims. away and the potential about 35,000 volts. By measuring the size of the object and images, and the distance between them, it is easy to find the position of the source from which the rays emanate. When this is done it is found that the rays proceed from the extreme end

of the point and not at some distance from it. The visible divergence of the brush does not start exactly from the point but at some little distance in front of it. It would seem therefore that the point of the emanation of these rays does not coincide with that of the visible part of the brush-discharge.

The next step was to find if the effect could be produced after reflexion. This was shown with the following apparatus. A cardboard box was made of the shape shown in sketch.

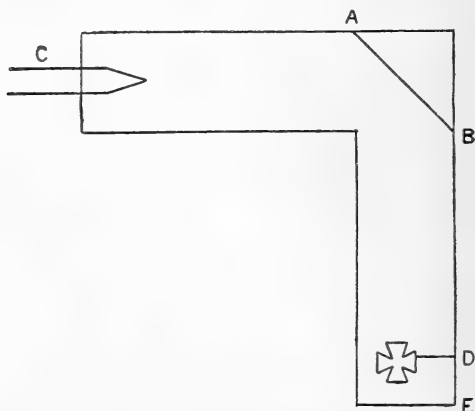

A B is a mirror, C the positive terminal of the machine, D an object, and E the photographic plate. Internal reflexion was carefully prevented and the experiment made in the dark room. The point was about 20 centims. from the mirror and the mirror about the same distance from the plate. The object, which was a piece of sheet-zinc, was from 1 to 5 centims. from the plate. When the machine was worked, and no mirror in position, it was found that the exposed plate was unaffected, the rays we may imagine being absorbed by the sides of the box. This experiment also shows that the fogging of the plate is not caused by any ozone which may accompany the discharge. When, however, the mirror is in position a distinct image is formed upon the plate after a slight exposure (5 minutes was usually given). Supposing the effects to be caused by the emission of electrified particles from the terminal it might be imagined that these would be reflected from the mirror and so turned from their course as to impinge upon the plate. In order to discover if this explanation be correct, the mirror A B (which was of glass in the first experiment) was replaced by a sheet of metal. Now, if electrified particles fall upon this and it be earth-connected, their electricity will

be immediately discharged, and therefore when they subsequently impinged upon the plate no effect would be produced. This was found not to be the case, as is shown by Pl. I. (fig. 3), which was produced by employing a piece of tin for the reflecting surface instead of glass.

That the metal plate did receive the impact of electrified particles was shown by the fact that sparks could be drawn from it from time to time.

In view of the statement of Tesla, that the efficiency of the metals as regards their reflecting powers for x -rays follows their order in the voltaic series, an attempt was made to test if any variation of reflecting power could be detected in the present case. For this purpose the metal reflecting-plate was varied, but the experimental results show that no conclusions can be drawn indicating any connexion between the reflecting-power and position in the electrochemical series. In fact the reflexion seems to depend upon the brightness of the surface, and therefore agrees exactly with the reflexion of light.

7. Penetrative Effects produced by the Brush-Discharge.

The remarkable results obtained by Röntgen and others induced an attempt to imitate the effects by the brush-discharge. For this purpose a sensitive plate was wrapped in brown paper (two folds), and on the paper were placed sundry small articles, such as coins, keys, &c., and the whole exposed to the brush-discharge. The experiment was made in a darkened room, and the point placed at about 5 to 6 centims. above the coins, the plate lying on the table. An exposure of 30 minutes was given, and on developing the plate the outline of the articles was distinctly shown. This experiment was repeated with brushes of different polarity and source (*i. e.* coil and machine), and in every case the same results were obtained. Probably the cause of this action is that the substances become charged and act inductively upon the silver salt in the sensitive film, causing a partial decomposition or production of a "latent image," which decomposition is carried still further in the process of development of the plate. The next step was to see if the outline of the bones could be produced without the flesh. Numerous experiments were made, but although in all cases the outline of the hand could be reproduced in no case did the bony skeleton show itself.

None of these effects could be obtained when a piece of vulcanized fibre was included in the wrapping. This substance has been shown by Giffard and others to be impervious to x -rays, and, of course, it is equally impervious to light.

As the thickness of the wrapping increased, definition on the developed plate became less and less. Thinking the effect might be due to the fact that the brown paper wrapping was not light-tight experiments were made to test this idea, and it should here be mentioned that the brown paper referred to is that which is used by photographic-plate makers to wrap sensitive plates in. Firstly, a plate wrapped in *one fold* was exposed for one hour to the light of an ordinary 8 c. p. glow-lamp illuminated by a 105 volt alternating current. A negative was obtained clearly showing images of the objects placed on the brown paper. This seemed to support the idea. Then a wrapped-up plate was simply exposed to diffused daylight for two hours. A very faint and blurred image of the coins &c. was obtained. Thus showing that the paper was not absolutely light-tight. Moreover, by exposing to very powerful light, such as that from burning magnesium and the lime-light, clearer effects were obtained, showing that the more powerful light is capable of getting through the paper better.

8. *Reproduction of Prints &c. by Brush-Discharge.*

Whilst engaged in obtaining a perfectly light-tight wrapping for the plates it happened that a piece of ordinary notepaper was used and the whole exposed to the action of the brush. On developing the plate a clearly-defined image of the watermark of the paper was produced (fig. 4). This induced trying to copy in a similar way printing, writing, pictures, &c. In every case this has been done with complete success. If a photograph, or a drawing, or printing, or writing be placed in contact with the sensitive film and exposed to the brush-discharge, a clearly-defined and very sharp reproduction is obtained. This seems to be more readily produced by the positive brush than by the negative. The effect on the plate can also be produced if the drawing be *not* in contact with the film but separated from it by one or two layers of paper or cardboard. In the latter case, however, the definition is not so good.

The effects produced when the drawings are in contact cannot be produced simply by keeping the plate and print in contact, at any rate for the same time as was used in my experiments, but can be brought about by exposing the plate to a powerful light, providing the wrappings are not too many.

One of the results of these experiments, of a somewhat startling character perhaps, is that the writing on a letter inside an envelope can be reproduced. It may be some

comfort, however, to know that there is considerable difficulty in recognizing the words owing to the folding of the paper, and thus one word coming immediately on the top of another. Fig. 5 shows the result obtained when a printed invitation-card enclosed in an envelope was exposed to the brush-discharge, the envelope being placed on the sensitive film. Notice the texture of the paper, and the opacity caused by the gum and double thickness of paper.

Light from the Discharge.

The great similarity between the effects recorded in the foregoing pages and those produced by ordinary light led to experiments being made to compare them.

The first point which suggested itself was to see whether the interposition of a body which was transparent to ordinary light, between the point and plate, made any difference in the result. A plate of clear glass was used, and the shadow of an object obtained. No difference was observed in the sharpness of the image. The glass was now blackened with lamp-black until it was so opaque to light that the flame of an ordinary candle could not be seen through it when it was held at a distance of 5 centims. from the flame. When this was held between the point and the photographic plate no effect whatever could be obtained.

Again, the law of inverse squares was proved in the following manner:—A small cross cut out of thin sheet-zinc was placed at a certain distance from the sensitive plate and its shadow obtained. The plate was now moved so that the shadow should fall upon a different part of the film, and the object was placed at a different distance away. Another shadow was now obtained. This was of a different size to the former. The two figures were then measured, and the sizes compared with the object and the distance of the brush.

These results therefore indicate that the effects are produced by the light which the brush emits. Moreover, after many trials, I have been enabled to reproduce all the effects with artificial sources of light. Many of them can be produced by employing daylight, and probably all could thus be formed, but the length of exposure required has hitherto prevented this from being done.

But, notwithstanding this apparently simple explanation, it is quite possible that we have something else taking place at the same time.

Suppose that the point is the centre of a disturbance from which waves are emitted. These waves will be of various lengths, some capable of affecting the optic nerve, and some

of shorter and some of longer wave-length than these. The reduction of the silver salts in the sensitive film may be caused by more than one kind of these waves. Before then it is possible to say that the effects are caused by the actinic power of the waves of short wave-length only, it is necessary to separate these waves in some such manner as that employed by Tyndall to separate heat-waves from those of light. Various experiments have been made to do this, but hitherto without success. The investigation is being pursued in this direction.

The actual amount of light given out by the brush-discharge is not much, and in the reflexion experiments which have been described it was found impossible for the most delicate eye, even after being kept in absolute darkness for a considerable time, to distinguish the outline of the object; but the shadow was nevertheless easily produced on the photographic plate. The numerous experiments which have been made show that, so far as one can judge, the effects produced by the brush are far more definite than would be expected, when the very small luminosity of the discharge is remembered. Or, in other words, that the emanation from the point contains a much larger proportion of rays capable of bringing about chemical decomposition than would be supposed when we remember only its luminosity.

In order that some approximation might be obtained between the light-giving power of the discharge and ordinary light, the following experiment was made. A comparison was first obtained between the light from a standard candle and the smallest burner procurable, the gas being burnt under the usual conditions for regulating the pressure. This burner was now compared with the light from the brush. The ordinary Bunsen-photometer, as used in gas-testing, was employed, and the light from the machine carefully screened off. In order that a good brush might be obtained an "earth" was placed near the terminal. The actual figures obtained varied with the climatic conditions, but not so much as would be expected, and the following numbers may be taken as an approximation, but, of course, only an approximation, to the relative luminosity of a standard candle and the brush from the machine used.

Distance of candle from photometer . . . 60 inches.

Distance of light " " . . . 3.25 inches.

Therefore, Candle : Light :: 3600 : 10.56.

Distance of light from photometer . . . 56 inches.

Distance of positive brush from photometer . 4 "

Therefore, Light from positive brush : Candle :: 1 : 267,200.

The light from the negative point is less than that from the positive. Brass points were used when making this comparison, but no difference was observed with other points. The potential-difference was about 30,000 volts.

Comparison of the Actinic Power of the Brush with that of Light.

In order to roughly test this an ordinary negative was taken and fixed in a frame together with a piece of bromide-paper. The frame was then exposed in the dark room to the light from a standard wax-candle. The same negative was then treated in the same way and exposed to the brush-discharge for a given time. The prints were then fixed and compared in order to see if they were over or under exposed. The experiments were then repeated until the effects were equal. After many experiments the nearest comparison that could be obtained was that the light from the candle at a distance of 15 centim. and 20 seconds' exposure produced the same effect as that *from the positive brush at the same distance and 15 minutes' exposure.* From this the relative powers would be as 1 to 45. The potential-difference when making these tests was about 30,000 volts.

On comparing this number with that obtained from the photometric experiments it will be seen how widely they differ, and it may therefore be considered as certain that the emanation from the point consists very largely of those waves which are capable of bringing about chemical changes.

IV. *On the Analogy of some Irregularities in the Yearly Range of Meteorological and Magnetic Phenomena.* By Dr. VAN RIJCKEVORSEL*.

[Plate II.]

AT the Toronto Meeting of the British Association † I called the attention of Section A to the fact that if the normal temperatures for every day of the year are plotted down in a curve, such curves are strikingly similar for stations spread over a very large area. An area which is larger than our continent for some of the particulars shown by these curves, while for others it extends over Western Europe only, or over part of it.

I am now able, to a certain degree, to give an answer to the query at the end of that paper: "Is it temperature alone of which the irregularities are so extremely regular? How

* Communicated by the Author.

† Paper published in the Phil. Mag. for May 1898.

does the barometer behave? Do the winds, do the magnetic elements, show something pointing to a common origin?" The answer is most certainly a positive one, as I hope to show now.

On the diagram (Plate II.) the uppermost curve, marked T, shows the temperature of every day of the year for the Helder in the Netherlands. The next curve, marked H, shows the horizontal, and the following one Z the vertical component of the earth's magnetic force as shown by the registering instruments at Utrecht. The curve marked R the rainfall at the same station. The curve marked P shows the barometric pressure at Greenwich; the last curve, D, the magnetic declination at the same station.

T shows the mean of 50 years' observations, H of 33 years between 1857 and 1896, Z of 30 years in the same period. For the magnetic data it is not always possible to use all the years for which values are available; for if in any case a serious break occurs in a series, which cannot be safely bridged over by fictitious values, or if a discontinuity occurs such as may be occasioned by a slight alteration in the instrument or in the adjustment of the scale, it is, as a rule, necessary to reject that whole year—this for more than one reason, but chiefly on account of the secular variation which is so irregular. It is unnecessary, however, to explain this now at any length.

R is the result of the 40 years 1856-95, P of the 18 years discussed by Mr. Glaisher*, viz. 1841-58, and lastly D of the 30 years 1865-94, of which I owe the three years which have not been published in the publications of the Observatory to the courtesy of the Astronomer-Royal.

Of course not all these series are of the same quality; some are decidedly not long enough; but although a large amount of material is still being computed, I am at present only able to show what there is in this diagram. The 19 years for air-pressure are decidedly not enough, and at the same time all those who are interested in terrestrial magnetism can form a judgment for themselves as to the intrinsic worth of the data for the vertical component. But for my present aim the material is about sufficient.

All the curves have been smoothed down in the same manner as explained in my first paper on this subject. For the magnetic curves, however, a preliminary operation was thought to be advisable, because the effect of the secular variation throughout the year would otherwise tilt the curves and render them less easily comparable with the others. This very simple operation was to take the difference between the

* 9th and 10th Reports of the British Meteorological Society.

mean for the ten first days of the year and that for the ten last days, and to interpolate this difference over the days of the year. The secular change has been taken into consideration in no other way; so that the figures from which these curves are drawn are simply the mean of the scale-readings for a certain number of years. Except for my purpose, they have therefore no value whatever.

The scales on which these six curves are drawn are also purely arbitrary. For H and Z even the scale-divisions as published in the annals of the *Koninklijk Nederlandsch meteorologisch Instituut* at Utrecht have not been reduced to any of the customary magnetic units. The factors by which the original figures have been multiplied in order to form the ordinates of these curves, ranging from 4 to $\frac{1}{2}$, were simply chosen so that the consecutive maxima and minima of the different curves should be, on an average, approximatively of the same importance. In other words, in the vertical dimensions the curves have been compressed or expanded so as to render the phenomenon I wish to show as prominent as possible.

And I think it will be admitted that it is prominent. Of a few doubtful points I will speak later on. But if we except these for the present, I think that it is perfectly apparent that, however dissimilar the general behaviour of the individual curves may be, every single maximum and every minimum in one curve is, with an astonishing regularity, repeated in all the others. Far from it that the curves should be parallel. In many cases a maximum in one curve occurs earlier or later than in most of the others. In still more cases, what is a large bump or a deep valley in one curve may find its correspondent in a hardly perceptible movement in another curve. A few of these differences in behaviour shall be, later on, explained away in a satisfactory manner. Others may be due to insufficiency, as yet, of the data at command. But even if a certain—decidedly small—number of instances should remain where one of the curves really has a secondary maximum and accompanying minimum not shown by the others, why should it not? It may be a local anomaly; it may be that indeed for, say, the barometer an agent enters also upon the scene which has less grip, or none at all, upon the thermometer or the magnetometers. There are certainly not many such exceptions to the general phenomenon shown in the curves under discussion. Indeed, they are so few that I incline to think that we may predict even now that as soon as we shall be possessed of a sufficient number of sufficiently good observations in every case it will indeed be found that to every

irregularity in one yearly curve, either for any magnetic or any meteorologic phenomenon, a corresponding irregularity will be apparent in all the other curves for the same region, if not always, as will be shown, for the same station. But even if some doubtful point should remain, I think proof is so abundant even now that, even if I should be found ultimately to have overrated it in some instances, this can no more invalidate the principle.

Another very valuable test for my opinion that the analogies pointed out here cannot be accidental, is furnished by this diagram for Paris*. The uppermost line shows the temperature as resulting from 130 years' observations. The lower one shows the magnetic declination, but this is the result of only 12 years of observation between 1785 and 1796 by Cassini. Not very good observations we should now call them: there are several breaks and changes of continuity which I had to bridge over as best I could. Moreover, the readings were not taken rigorously at the same hour of the day. I think this is more than sufficient, with such a short series, to account for a certain number of doubts and queries which I cannot explain away. But upon the whole I think it will be admitted that the concordance between the two curves is just as satisfactory as in the large diagram. Therefore, at least also in this respect, things a century ago were what they are now.

One possibility I must point out. It may be that one or more of these curves ought in reality to be inverted. This seems preposterous. Still, with so many maxima and minima following each other in rapid succession, it is not so. (I have numbered 17 maxima; but I am perfectly sure that a larger number than this are just as real as these, only they are so small as not to be detected yet, as long as we are obliged to smooth down the curves to such an extent.) Take a maximum and the following minimum, which slightly precedes the corresponding feature of the other curves, and invert the curve: they will then simply be converted into a maximum and a preceding minimum slightly lagging behind a similar feature in the other curves. One of my magnetic curves is inverted—needless to say which, because a scale may read from right to left or from left to right. But also I have had serious doubts as to the advisability of inverting one or two others.

You will see at once that in some cases my vertical lines †

* This diagram is not reproduced, as the text is sufficiently clear without it.

† Continuous vertical lines connect the maxima, lines of long dots the minima belonging together.

indicate a maximum where, in good faith, such a thing is not to be discovered. This is quite true. I call attention to the lines 6, 13, 14, 15. There is certainly no, or hardly an, apparent maximum in the temperature-line there. But if we look for a moment at this larger collection of temperature-curves*, of which it is not possible to give such a large diagram, it will at once be seen that for the three last of these numbers the curves for the whole of the United Kingdom show a small but decided maximum in all these cases. For 13 this also appears in some curves for southern stations, such as Montpellier. On the other hand, at 6 the maximum which the curve for the Helder does not show is most distinctly shown by the curves of the stations to the south and east of the Netherlands.

There is, I think, a most valuable use of the method here explained. For one phenomenon any of the maxima may be less apparent than for another. It may even be not at all so, (It would seem as if magnetism were a more sensitive organ than meteorology.) But as soon as some of the curves show a certain maximum, there is some presumption that the others ought to do so, even if they do not. In other words, that there is at that particular moment an influence at work which would manifest itself by creating a maximum in those curves also, if only our series of observations were long enough or the methods of observation sensitive enough. If at some moment of the year the vertical intensity or the rainfall show a maximum or minimum, even an unimportant one, the temperature and declination must show it too—it may be smaller or larger, or somewhat larger or later, but it must be there. And should it decidedly not be there, depend upon it that here is something worth investigating.

But again the point now under discussion gives us a valuable clue to the direction in which we must look for the origin of the anomalies of our curves; and this may lead perhaps in some cases to a guess as to their causes. From what has just been said it is of course very probable that the maxima in 14 and 15 are due to the influence of some cause which has its seat to the north or northwest of the Netherlands, the one in 13 to one in the southwest, but that in 6 to an influence coming from the southeast.

I must here refer again to a very remarkable minimum occurring in some curves on or about the 1st of July, which has been mentioned in the Toronto paper†. The mass of material which has since come into my possession has shown

* These diagrams also are not reproduced.

† *Phil. Mag.* May 1898, p. 465.

me that this is indeed more widely spread and more enigmatic than I at first supposed. However, I think I am able now to point out with a certain degree of probability where it originates. This is the first case in which I really could do more than show the direction in which this origin ought to be found.

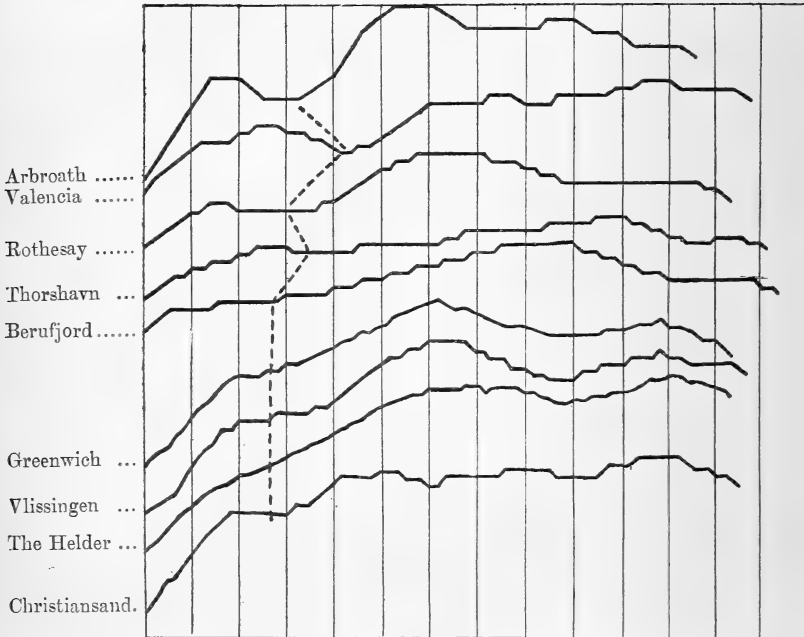

This second diagram shows for a certain number of stations the daily mean temperature for the month of July and parts of June and August. The order in which the curves are arranged is more or less the same as that in which the importance of this minimum decreases. At the same time—and this is important—the order is such that the first places are very near some point to the west of Scotland, and that the others gradually go further and further away from that centre.

Only four of these show a decided minimum; the most pronounced one occurs at Arbroath in the east of Scotland, and the next at Valencia; the two others are Rothesay near the west coast of Scotland and Thorshavn on the Faröe Islands.

After these places the minimum assumes a less decided character; it is no longer a valley, but only a less steep incline of the ascending curve. These stations form another circle round Scotland; they are: Berufjord, on the east coast

of Iceland*, Christiansand, on the west coast of Norway, Greenwich, and the stations in the Netherlands.

Much importance must be attached to the fact that at Stykkisholm, on the west coast of Iceland, this minimum is not at all perceptible, and hardly, if at all, at Brest. And some importance also to the fact that it sets in first at the two Scotch stations, next at Valencia and the Faröer.

If you consider these facts I think that you will own that here is an anomaly which must have its origin at the coast of the west of Scotland, and probably at no great distance. For if this origin were at a greater distance from the Scottish coast, it would be hardly conceivable that its influence should die out so rapidly on the two straight lines Thorshavn, Beruffjord, Stykkisholm, and Scotland, England, Brest.

Thus far I believe my conjecture is backed by what constitutes a certain amount of proof. But the road, or rather roads, which this minimum subsequently follows through part of Europe is decidedly bewildering. Brussels shows it, Paris most decidedly; so do Lyons, Montpellier, Triest, and Klagenfurt; while, curiously enough, south and north of the line uniting these stations, both in the German and the Italian stations, I cannot find a trace of it.

But in the North of Europe also there are decidedly some traces of it. Both Copenhagen and Haparanda show them, so do Baltischport and Kem on the western side of the White Sea. In this part of Europe the boundary beyond which this feature is not traceable is a line passing west of Königsberg, Petersburg, and Archangel. Some traces of this minimum are also to be found in a group of stations of which Warsaw is the northernmost.

There is another fact which may be connected with the strange distribution of this minimum. Nearly in the whole of Russia and the North of Europe the highest point of the whole curve has a strong tendency to occur in August, in the very beginning for the eastern stations with a single maximum, while those with a double summer maximum show the highest one about the middle of August. This may, for instance, be seen in the curves for Thorshavn, Beruffjord, and Christiansand. In the west and south of Europe, on the contrary, the July maximum, on an average, is decidedly,

* I owe these northern stations to the kindness of Dr. A. Paulsen, Director of the Meteorological Observatory at Copenhagen. I owe thanks to a great many more gentlemen for the kindness with which material, even manuscript, was placed at my disposal; but their names will come more naturally when the time shall ultimately have come to publish the whole of this investigation.

although not much, higher than the August one. This is an indication of the southern origin of this July maximum. May not this be an explanation? Late in June Europe is invaded from a point off the Scottish coast by a strong minimum, but a week or so later by a strong maximum from the south or southwest, let us say tropical Africa. Therefore it is probable that the fight, so to speak, of these two features, in the first place causes the distribution just spoken of, and that the curious particulars which accompany it must find their explanation in local circumstances.

A wild hypothesis? I know it is. But I give it in order to show how vividly some meteorological problems are put before us by this method, and how a path is shown at the same time to their evolution. For can there be much doubt but that, as soon as we shall be possessed of more data, not about temperature only, more and more of these problems must make great progress towards a solution? One curve for magnetic declination or for rainfall may throw a ray of light on an intricate point which at once solves it.

Another argument to the same purpose. There will be seen, not without some effort perhaps, a very slight minimum between the 10th and 15th of May in the three upper curves (Pl. II.). There are other features of the same importance, of a greater one even. There need be no fear of my discussing them all, for the very plausible reason that I do not know anything about them. They may either prove interesting some day, or vanish completely, when meteorologists shall be able to discuss longer series of observations. But this one is worth a moment's notice, for it is really the mark of the so-much discussed "Ice-saints." You will notice a trace of it in the three upper curves, not in the two lower ones. (The rainfall is too doubtful to be quoted here.) Well, these two lower curves belong to Greenwich, and you will see that the hand-mark, if I may express myself thus, of these cold saints tends to vanish in the British Isles. The temperature-curve for Greenwich indeed shows it still, that for Valencia perhaps, but certainly in Scotland it is not visible. Here again the southern, or southeastern, origin of this phenomenon, which I hinted at at Toronto, is confirmed by other curves than those for the temperature.

As hinted at before, some of these curves leave for the moment a doubt. It will be seen that between July and November I left in some of the vertical lines a break in the lower regions of my diagram. In nearly every case it is only the barometer that is at fault. I already have stated the cause: the series of 19 years which I used is not long enough. I regret that I have been unable to be ready in time with a

longer series. But I fully expect that when this is quite computed these doubts will be cleared away.

There is, however, another class of doubts which must perhaps be allowed as yet to stand over. It will be seen that between the maxima marked 15 and 16 I suggest for the upper curves two minima and an unimportant maximum between them, while lower down I have only been able to trace a single minimum. This may of course be consistent with the facts. Eventually for one phenomenon a certain maximum may become so slight that it can no longer be detected, at least not by our present methods; and thus the two minima before and after it may merge into one, although other phenomena show two minima.

Another fact of the same nature occurs perhaps between the July and August maxima, between the vertical lines 9 and 10. The dotted line between these two is much more crooked than the lines 9 and 10 seem to warrant. On the other hand, nearly all the lines show very slight indications that this minimum is indeed a double one separated by a very slight maximum. But this feature is so faint that I did not feel justified for the present in drawing the vertical lines accordingly.

Again the line 17 is a doubtful one. Of course this is partly only a technical difficulty. Where the curves are so near together as in this part of the diagram, the vertical lines must seem—not really be—more crooked than they are in the summer part of the diagram, where they expand to such a length. Still I have a feeling that line 17 is also in reality composed of two maxima, of which one, in December, ought to have the number 17, and another, chiefly in January, the new number 18.

I might of course multiply instances like these, but I feel that this is at present useless. The seventeen lines which I have numbered will, I think, be found in future to be a near approximation to truth for Western Europe so far as the most remarkable features go. But numberless other subsidiary vertical lines may eventually be filled in in course of time when more and better material shall be at hand than I could avail myself of as yet.

But this, I think, is the result of this part of the work: There is one potent cause which for a large part rules all meteorological and magnetic phenomena, and influences them all in a similar way nearly simultaneously.

I do not of course pretend to teach a new doctrine in these words, but I think I have shown a new proof of it. And also how largely the simple method which I have used may in future contribute to the solution of meteorological problems.

V. *The Age of the Earth as an Abode fitted for Life.*
By the Right Hon. Lord KELVIN, G.C.V.O.*

§ 1. **T**HE age of the earth as an abode fitted for life is certainly a subject which largely interests mankind in general. For geology it is of vital and fundamental importance—as important as the date of the battle of Hastings is for English history—yet it was very little thought of by geologists of thirty or forty years ago; how little is illustrated by a statement †, which I will now read, given originally from the presidential chair of the Geological Society by Professor Huxley in 1869, when for a second time, after a seven years' interval, he was president of the Society.

“I do not suppose that at the present day any geologist would be found ... to deny that the rapidity of the rotation of the earth *may* be diminishing, that the sun *may* be waxing dim, or that the earth itself *may* be cooling. Most of us, I suspect, are Gallios, ‘who care for none of these things,’ being of opinion that, true or fictitious, they have made no practical difference to the earth, during the period of which a record is preserved in stratified deposits.”

§ 2. I believe the explanation of how it was possible for Professor Huxley to say that he and other geologists did not care for things on which the age of life on the earth essentially depends, is because he did not know that there was valid foundation for any estimates worth considering as to absolute magnitudes. If science did not allow us to give any estimate whatever as to whether 10,000,000 or 10,000,000,000 years is the age of this earth as an abode fitted for life, then I think Professor Huxley would have been perfectly right in saying that geologists should not trouble themselves about it, and biologists should go on in their own way, not enquiring into things utterly beyond the power of human understanding and scientific investigation. This would have left geology much in the same position as that in which English history would be if it were impossible to ascertain whether the battle of Hastings took place 800 years ago, or 800 thousand years ago, or 800 million years ago. If it were absolutely impossible to find out which of these periods is more probable than the other, then I agree we might be Gallios as to the date of the Norman Conquest. But a

* Communicated by the Author, being the 1897 Annual Address of the Victoria Institute with additions written at different times from June 1897 to May 1898.

† In the printed quotations the italics are mine in every case, not so the capitals in the quotation from Page's Text-book,

change took place just about the time to which I refer, and from then till now geologists have not considered the question of absolute dates in their science as outside the scope of their investigations.

§ 3. I may be allowed to read a few extracts to indicate how geological thought was expressed in respect to this subject, in various largely used popular text-books, and in scientific writings which were new in 1868, or not so old as to be forgotten. I have several short extracts to read and I hope you will not find them tedious.

The first is three lines from Darwin's "Origin of Species," 1859 Edition, p. 287.

"In all probability a far longer period than 300,000,000 years has elapsed since the latter part of the secondary period."

Here is another still more important sentence, which I read to you from the same book :—

"He who can read Sir Charles Lyell's grand work on the Principles of Geology, which the future historian will recognize as having produced a revolution in natural science, yet does not admit how *incomprehensibly vast* have been the past periods of time, *may at once close this volume.*"

I shall next read a short statement from Page's 'Advanced Students' Text-Book of Geology,' published in 1859 :—

"Again where the FORCE seems unequal to the result, the student should never lose sight of the element TIME: *an element to which we can set no bounds in the past*, any more than we know of its limit in the future."

"It will be seen from this hasty indication that there are two great schools of geological causation—the one ascribing every result to the ordinary operations of Nature, combined with the element of *unlimited time*, the other appealing to agents that operated during the earlier epochs of the world with greater intensity, and also for the most part over wider areas. *The former belief is certainly more in accordance with the spirit of right philosophy*, though it must be confessed that many problems in geology seem to find their solution only through the admission of the latter hypothesis."

§ 4. I have several other statements which I think you may hear with some interest. Dr. Samuel Haughton, of Trinity College, Dublin, in his 'Manual of Geology,' published in 1865, p. 82, says :—

"The infinite time of the geologists is in the past; and *most of their speculations regarding this subject seem to imply the absolute infinity of time*, as if the human imagination was unable to grasp the period of time requisite for the formation of a few inches of sand or feet of mud, and its subsequent consolidation into rock." (This delicate satire is certainly not overstrained.)

"Professor Thomson has made an attempt to calculate the length of time during which the sun can have gone on burning at the present rate, and has come to the following conclusion :—'It seems, on the whole, most

probable that the sun has not illuminated the earth for 100,000,000 years, and almost certain that he has not done so for 500,000,000 years. As for the future, we may say with equal certainty, that the inhabitants of the earth cannot continue to enjoy the light and heat essential to their life for many million years longer, unless new sources, now unknown to us, are prepared in the great storehouse of creation."

I said that in the sixties and I repeat it now; but with charming logic it is held to be inconsistent with a later statement that the sun has not been shining 60,000,000 years; and that both that and this are stultified by a still closer estimate which says that probably the sun has not been shining for 30,000,000 years! And so my efforts to find some limit or estimate for Geological Time have been referred to and put before the public, even in London daily and weekly papers, to show how exceedingly wild are the wanderings of physicists, and how mutually contradictory are their conclusions, as to the length of time which has actually passed since the early geological epochs to the present date.

Dr. Haughton further goes on—

"This result (100 to 500 million years) of Professor Thomson's, although very liberal in the allowance of time, has offended geologists, because, having been accustomed to deal with time as an infinite quantity at their disposal, they feel naturally embarrassment and alarm at any attempt of the science of Physics to place a limit upon their speculations. It is quite possible that even a hundred million of years may be greatly in excess of the actual time during which the sun's heat has remained constant."

§ 5. Dr. Haughton admitted so much with a candid open mind; but he went on to express his own belief (in 1865) thus:—

"Although I have spoken somewhat disrespectfully of the geological calculus in my lecture, yet I believe that the time during which organic life has existed on the earth is practically infinite, because it can be shown to be so great as to be inconceivable by beings of our limited intelligence."

Where is inconceivableness in 10,000,000,000? There is nothing inconceivable in the number of persons in this room, or in London. We get up to millions quickly. Is there anything inconceivable in 30,000,000 as the population of England, or in 38,000,000 as the population of Great Britain and Ireland, or in 352,704,863 as the population of the British Empire? Not at all. It is just as conceivable as half a million years or 500 millions.

§ 6. The following statement is from Professor Jukes's 'Students' Manual of Geology':—

"The time required for such a slow process to effect such enormous results must of course be taken to be inconceivably great. The word 'inconceivably' is not here used in a vague but in a literal sense, to indicate that the lapse of time required for the denudation that has produced the present surfaces of some of the older rocks, is vast beyond any idea of time which the human mind is capable of conceiving."

“ Mr. Darwin, in his admirably reasoned book on the origin of species, so full of information and suggestion on all geological subjects, estimates the time required for the denudation of the rocks of the Weald of Kent, or the erosion of space between the ranges of chalk hills, known as the North and South Downs, at *three hundred millions of years*. The grounds for forming this estimate are of course of the vaguest description. It may be possible, perhaps, that the estimate is a hundred times too great, and that the real time elapsed did not exceed three million years, but, on the other hand, it is just as likely that the time which actually elapsed since the first commencement of the erosion till it was nearly as complete as it now is, was really a hundred times greater than his estimate, or thirty thousand millions of years.”

§ 7. Thus Jukes allowed estimates of anything from 3 millions to 30,000 millions as the time which actually passed during the denudation of the Weald. On the other hand Professor Phillips in his Rede lecture to the University of Cambridge (1860), decidedly prefers one inch per annum to Darwin's one inch per century as the rate of erosion ; and says that most observers would consider even the one inch per annum too small for all but the most invincible coasts ! He thus, on purely geological grounds, reduces Darwin's estimate of the time to less than one one-hundredth. And, reckoning the actual thicknesses of all the known geological strata of the earth, he finds 96 million years as a possible estimate for the antiquity of the base of the stratified rocks ; but he gives reasons for supposing that this may be an over-estimate, and he finds that from stratigraphical evidence alone, we may regard the antiquity of life on the earth as possibly between 38 millions and 96 millions of years. Quite lately a very careful estimate of the antiquity of strata containing remains of life on the earth has been given by Professor Sollas, of Oxford, calculated according to stratigraphical principles which had been pointed out by Mr. Alfred Wallace. Here it is* :—“ So far as I can at present see, the lapse of time since the beginning of the Cambrian system is probably less than 17,000,000 years, even when computed on an assumption of uniformity, which to me seems contradicted by the most salient facts of geology. Whatever additional time the calculations made on physical data can afford us, may go to the account of pre-Cambrian deposits, of which at present we know too little to serve for an independent estimate.”

§ 8. In one of the evening *Conversazioni* of the British Association during its meeting at Dundee in 1867 I had a conversation on geological time with the late Sir Andrew Ramsay, almost every word of which remains stamped on

* “The Age of the Earth,” ‘Nature,’ April 4th, 1895.

my mind to this day. We had been hearing a brilliant and suggestive lecture by Professor (now Sir Archibald) Geikie on the geological history of the actions by which the existing scenery of Scotland was produced. I asked Ramsay how long a time he allowed for that history. He answered that he could suggest no limit to it. I said, "You don't suppose things have been going on always as they are now? You don't suppose geological history has run through 1,000,000,000 years?" "Certainly I do." "10,000,000,000 years?" "Yes." "The sun is a finite body. You can tell how many tons it is. Do you think it has been shining on for a million million years?" "I am as incapable of estimating and understanding the reasons which you physicists have for limiting geological time as you are incapable of understanding the geological reasons for our unlimited estimates." I answered, "You can understand physicists' reasoning perfectly if you give your mind to it." I ventured also to say that physicists were not wholly incapable of appreciating geological difficulties; and so the matter ended, and we had a friendly agreement to temporarily differ.

§ 9. In fact, from about the beginning of the century till that time (1867), geologists had been nurtured in a philosophy originating with the Huttonian system: much of it substantially very good philosophy, but some of it essentially unsound and misleading: witness this, from Playfair, the eloquent and able expounder of Hutton:—

"How often these vicissitudes of decay and renovation have been repeated is not for us to determine; they constitute a series of which as the author of this theory has remarked, we neither see the beginning nor the end; a circumstance that accords well with what is known concerning other parts of the economy of the world. In the continuation of the different species of animals and vegetables that inhabit the earth, we discern neither a beginning nor an end; in the planetary motions where geometry has carried the eye so far both into the future and the past we discover no mark either of the commencement or the termination of the present order."

§ 10. Led by Hutton and Playfair, Lyell taught the doctrine of eternity and uniformity in geology; and to explain plutonic action and underground heat, invented a thermo-electric "perpetual" motion on which, in the year 1862, in my paper on the "Secular Cooling of the Earth"* published in the 'Transactions of the Royal Society of Edinburgh,' I commented as follows:—

* Reprinted in Thomson and Tait, 'Treatise on Natural Philosophy,' 1st and 2nd Editions, Appendix D (g).

“To suppose, as Lyell, adopting the chemical hypothesis, has done*, that the substances, combining together, may be again separated electrolytically by thermo-electric currents, due to the heat generated by their combination, and thus the chemical action and its heat continued in an endless cycle, violates the principles of natural philosophy in exactly the same manner, and to the same degree, as to believe that a clock constructed with a self-winding movement may fulfil the expectations of its ingenious inventor by going for ever.”

It was only by sheer force of reason that geologists have been compelled to think otherwise, and to see that there was a definite beginning, and to look forward to a definite end, of this world as an abode fitted for life.

§ 11. It is curious that English philosophers and writers should not have noticed how Newton treated the astronomical problem. Playfair, in what I have read to you, speaks of the planetary system as being absolutely eternal, and unchangeable: having had no beginning and showing no signs of progress towards an end. He assumes also that the sun is to go on shining for ever, and that the earth is to go on revolving round it for ever. He quite overlooked Laplace's nebular theory; and he overlooked Newton's counterblast to the planetary “perpetual motion.” Newton, commenting on his own ‘First Law of Motion,’ says, in his terse Latin, which I will endeavour to translate, “But the greater bodies of planets and comets moving in spaces less resisting, keep their motions longer.” That is a strong counterblast against any idea of eternity in the planetary system.

§ 12. I shall now, without further preface, explain, and I hope briefly, so as not to wear out your patience, some of the arguments that I brought forward between 1862 and 1869, to show strict limitations to the possible age of the earth as an abode fitted for life.

Kant † pointed out in the middle of last century, what had not previously been discovered by mathematicians or physical astronomers, that the frictional resistance against tidal currents on the earth's surface must cause a diminution of the earth's rotational speed. This really great discovery in

* ‘Principles of Geology,’ chap. xxxi. ed. 1853.

† In an essay first published in the Königsberg *Nachrichten*, 1754, Nos. 23, 24; having been written with reference to the offer of a prize by the Berlin Academy of Sciences in 1754. Here is the title-page, in full, as it appears in vol. vi. of Kant's Collected Works, Leipzig, 1839:—*Untersuchung der Frage: Ob die Erde in ihrer Umdrehung um die Achse, wodurch sie die Abwechselung des Tages und der Nacht hervorbringt, einige Veränderung seit den ersten Zeiten ihres Ursprunges erlitten habe, welches die Ursache davon sei, und woraus man sich ihrer versichern könne? welche von der Königlichen Akademie der Wissenschaften zu Berlin zum Preise aufgegeben worden, 1754.*

Natural Philosophy seems to have attracted very little attention,—indeed to have passed quite unnoticed,—among mathematicians, and astronomers, and naturalists, until about 1840, when the doctrine of energy began to be taken to heart. In 1866, Delaunay suggested that tidal retardation of the earth's rotation was probably the cause of an outstanding acceleration of the moon's mean motion reckoned according to the earth's rotation as a timekeeper found by Adams in 1853 by correcting a calculation of Laplace which had seemed to prove the earth's rotational speed to be uniform*. Adopting Delaunay's suggestion as true, Adams, in conjunction with Professor Tait and myself, estimated the diminution of the earth's rotational speed to be such that the earth as a timekeeper, in the course of a century, would get 22 seconds behind a thoroughly perfect watch or clock rated to agree with it at the beginning of the century. According to this rate of retardation the earth, 7,200 million years ago, would have been rotating twice as fast as now: and the centrifugal force in the equatorial regions would have been four times as great as its present amount, which is $\frac{1}{289}$ of gravity. At present the radius of the equatorial sea-level exceeds the polar semi-diameter by $21\frac{1}{2}$ kilometres, which is, as nearly as the most careful calculations in the theory of the earth's figure can tell us, just what the excess of equatorial radius of the surface of the sea all round would be if the whole material of the earth were at present liquid and in equilibrium under the influence of gravity and centrifugal force with the present rotational speed, and $\frac{1}{4}$ of what it would be if the rotational speed were twice as great. Hence, if the rotational speed had been twice as great as its present amount when consolidation from approximately the figure of fluid equilibrium took place, and if the solid earth, remaining absolutely rigid, had been gradually slowed down in the course of millions of years to its present speed of rotation, the water would have settled into two circular oceans round the two poles: and the equator, dry all round, would be 64·5 kilometres above the level of the polar sea bottoms. This is on the supposition of absolute rigidity of the earth after primitive consolidation. There would, in reality, have been some degree of yielding to the gravitational tendency to level the great gentle slope up from each pole to equator. But if the earth, at the time of primitive consolida-

* 'Treatise on Natural Philosophy' (Thomson and Tait), § 830, ed. 1, 1867, and later editions; also 'Popular Lectures and Addresses,' vol. ii. (Kelvin), 'Geological Time,' being a reprint of an article communicated to the Glasgow Geological Society, February 27th, 1868.

tion, had been rotating twice as fast as at present, or even 20 per cent. faster than at present, traces of its present figure must have been left in a great preponderance of land, and probably no sea at all, in the equatorial regions. Taking into account all uncertainties, whether in respect to Adams' estimate of the rate of frictional retardation of the earth's rotatory speed, or to the conditions as to the rigidity of the earth once consolidated, we may safely conclude that the earth was certainly not solid 5,000 million years ago, and was probably not solid 1,000 million years ago*.

§ 13. A second argument for limitation of the earth's age, which was really my own first argument, is founded on the consideration of underground heat. To explain a first rough and ready estimate of it I shall read one short statement. It is from a very short paper that I communicated to the Royal Society of Edinburgh on the 18th December, 1865, entitled, "The Doctrine of Uniformity in Geology briefly refuted."

"The 'Doctrine of Uniformity' in Geology, as held by many of the most eminent of British Geologists, assumes that the earth's surface and upper crust have been nearly as they are at present in temperature, and other physical qualities, during millions of millions of years. But *the heat which we know, by observation, to be now conducted out of the earth yearly is so great, that if this action had been going on with any approach to uniformity for 20,000 million years, the amount of heat lost out of the earth would have been about as much as would heat, by 100° C., a quantity of ordinary surface rock of 100 times the earth's bulk. This would be more than enough to melt a mass of surface rock equal in bulk to the whole earth. No hypothesis as to chemical action, internal fluidity, effects of pressure at great depth, or possible character of substances in the interior of the earth, possessing the smallest vestige of probability, can justify the supposition that the earth's upper crust has remained nearly as it is, while from the whole, or from any part, of the earth, so great a quantity of heat has been lost.*"

§ 14. The sixteen words which I have emphasized in reading this statement to you (italics in the reprint) indicate the matter-of-fact foundation for the conclusion asserted. This conclusion suffices to sweep away the whole system of geological and biological speculation demanding an "inconceivably" great vista of past time, or even a few thousand million years, for the history of life on the earth, and approximate uniformity of plutonic action throughout that time; which, as we have seen, was very generally prevalent thirty years

* "The fact that the continents are arranged along meridians, rather than in an equatorial belt, affords some degree of proof that the consolidation of the earth took place at a time when the diurnal rotation differed but little from its present value. It is probable that the date of consolidation is considerably more recent than a thousand million years ago."—Thomson and Tait, 'Treatise on Natural Philosophy,' 2nd ed., 1883, § 830.

ago among British Geologists and Biologists; and which, I must say, some of our chiefs of the present day have not yet abandoned. Witness the Presidents of the Geological and Zoological Sections of the British Association at its meetings of 1893 (Nottingham), and of 1896 (Liverpool).

Mr. Teall: Presidential Address to the Geological Section, 1893. "The good old British ship 'Uniformity,' built by Hutton and refitted by Lyell, has won so many glorious victories in the past, and appears still to be in such excellent fighting trim, that I see no reason why she should haul down her colours either to 'Catastrophe' or 'Evolution.' Instead, therefore, of acceding to the request to 'hurry up' we make a demand for more time."

Professor Poulton: Presidential Address to the Zoological Section, 1896. "Our argument does not deal with the time required for the origin of life, or for the development of the lowest beings with which we are acquainted from the first formed beings, of which we know nothing. Both these processes may have required an immensity of time; but as we know nothing whatever about them and have as yet no prospect of acquiring any information, we are compelled to confine ourselves to as much of the process of evolution as we can infer from the structure of living and fossil forms—that is, as regards animals, to the development of the simplest into the most complex Protozoa, the evolution of the Metazoa from the Protozoa, and the branching of the former into its numerous Phyla, with all their Classes, Orders, Families, Genera, and Species. But we shall find that this is quite enough to necessitate a *very large increase in the time estimated by the geologist.*"

§ 15. In my own short paper from which I have read you a sentence, the rate at which heat is at the present time lost from the earth by conduction outwards through the upper crust, as proved by observations of underground temperature in different parts of the world, and by measurement of the thermal conductivity of surface rocks and strata, sufficed to utterly refute the Doctrine of Uniformity as taught by Hutton, Lyell, and their followers; which was the sole object of that paper.

§ 16. In an earlier communication to the Royal Society of Edinburgh*, I had considered the cooling of the earth due to this loss of heat; and by tracing backwards the process of cooling had formed a definite estimate of the greatest and least number of million years which can possibly have passed since the surface of the earth was everywhere red hot. I expressed my conclusion in the following statement †:—

* "On the Secular Cooling of the Earth," Trans. Roy. Soc. Edinburgh, vol. xxiii. April 28th, 1862, reprinted in Thomson and Tait, vol. iii. pp. 463–485, and Math. and Phys. Papers, art. xciv. pp. 295–311.

† "On the Secular Cooling of the Earth," Math. and Phys. Papers, vol. iii. § 11 of art. xciv.

“We are very ignorant as to the effects of high temperatures in altering the conductivities and specific heats and melting temperatures of rocks, and as to their latent heat of fusion. We must, therefore, allow very wide limits in such an estimate as I have attempted to make; but I think we may with much probability say that the consolidation cannot have taken place less than 20 million years ago, or we should now have more underground heat than we actually have; nor more than 400 million years ago, or we should now have less underground heat than we actually have. That is to say, I conclude that Leibnitz’s epoch of emergence of the *consistentior status* [the consolidation of the earth from red hot or white hot molten matter] was probably between those dates.”

§ 17. During the 35 years which have passed since I gave this wide-ranged estimate, experimental investigation has supplied much of the knowledge then wanting regarding the thermal properties of rocks to form a closer estimate of the time which has passed since the consolidation of the earth, and we have now good reason for judging that it was more than 20 and less than 40 million years ago; and probably much nearer 20 than 40.

§ 18. Twelve years ago, in a laboratory established by Mr. Clarence King in connexion with the United States Geological Survey, a very important series of experimental researches on the physical properties of rocks at high temperatures was commenced by Dr. Carl Barus, for the purpose of supplying trustworthy data for geological theory. Mr. Clarence King, in an article published in the ‘American Journal of Science’*, used data thus supplied, to estimate the age of the earth more definitely than was possible for me to do in 1862, with the very meagre information then available as to the specific heats, thermal conductivities, and temperatures of fusion, of rocks. I had taken 7000° F. (3781° C.) as a high estimate of the temperature of melting rock. Even then I might have taken something between 1000° C. and 2000° C. as more probable, but I was most anxious not to *under-estimate* the age of the earth, and so I founded my primary calculation on the 7000° F. for the temperature of melting rock. We know now from the experiments of Carl Barus † that diabase, a typical basalt of very primitive character, melts between 1100° C. and 1170°, and is thoroughly liquid at 1200°. The correction from 3871° C. to 1200° or $1/3.22$ of that value, for the temperature of solidification, would, with no other change of assumptions, reduce my estimate of 100 million to $1/(3.22)^2$ of its amount, or a little less than 10 million years; but the effect of pressure on the temperature of solidification must also be taken into

* ‘On the Age of the Earth,’ vol. xlv. January 1893.

† Phil. Mag. 1893, first half-year, pp. 186, 187, 301–305.

account, and Mr. Clarence King, after a careful scrutiny of all the data given him for this purpose by Dr. Barus, concludes that without further experimental data "we have no warrant for extending the earth's age beyond 24 millions of years."

§ 19. By an elaborate piece of mathematical book-keeping I have worked out the problem of the conduction of heat outwards from the earth, with specific heat increasing up to the melting-point as found by Rücker and Roberts-Austen and by Barus, but with the conductivity assumed constant; and, by taking into account the augmentation of melting temperature with pressure in a somewhat more complete manner than that adopted by Mr. Clarence King, I am not led to differ much from his estimate of 24 million years. But, until we know something more than we know at present as to the probable diminution of thermal conductivity with increasing temperature, which would shorten the time since consolidation, it would be quite inadvisable to publish any closer estimate.

§ 20. All these reckonings of the history of underground heat, the details of which I am sure you do not wish me to put before you at present, are founded on the very sure assumption that the material of our present solid earth all round its surface was at one time a white hot liquid. The earth is at present losing heat from its surface all round from year to year and century to century. We may dismiss as utterly untenable any supposition such as that a few thousand or a few million years of the present regime in this respect was preceded by a few thousand or a few million years of heating from without. History, guided by science, is bound to find, if possible, an antecedent condition preceding every known state of affairs, whether of dead matter or of living creatures. Unless the earth was created solid and hot out of nothing, the regime of continued loss of heat must have been preceded by molten matter all round the surface.

§ 21. I have given strong reasons* for believing that *immediately* before solidification at the surface, the interior was solid close up to the surface: except comparatively small portions of lava or melted rock among the solid masses of denser solid rock which had sunk through the liquid, and possibly a somewhat large space around the centre occupied by platinum, gold, silver, lead, copper, iron, and other dense metals, still remaining liquid under very high pressure.

§ 22. I wish now to speak to you of depths below the

* "On the Secular Cooling of the Earth," vol. iii. Math. and Phys. Papers, §§ 19-33.

great surface of liquid lava bounding the earth before consolidation; and of mountain heights and ocean depths formed probably a few years after a first emergence of solid rock from the liquid surface (see § 24, below), which must have been quickly followed by complete consolidation all round the globe. But I must first ask you to excuse my giving you all my depths, heights, and distances, in terms of the kilometre, being about six-tenths of that very inconvenient measure the English statute mile, which, with all the other monstrosities of our British metrical system, will, let us hope, not long survive the legislation of our present Parliamentary session destined to honour the sixty years' Jubilee of Queen Victoria's reign by legalising the French metrical system for the United Kingdom.

§ 23. To prepare for considering consolidation at the surface let us go back to a time (probably not more than twenty years earlier as we shall presently see—§ 24) when the solid nucleus was covered with liquid lava to a depth of several kilometres; to fix our ideas let us say 40 kilometres (or 4 million centimetres). At this depth in lava, if of specific gravity 2.5, the hydrostatic pressure is 10 tons weight (10 million grammes) per square centimetre, or ten thousand atmospheres approximately. According to the laboratory experiments of Clarence King and Carl Barus* on Diabase, and the thermodynamic theory † of my brother, the late Professor James Thomson, the melting temperature of diabase is 1170° C. at ordinary atmospheric pressure, and would be 1420° under the pressure of ten thousand atmospheres, if the rise of temperature with pressure followed the law of simple proportion up to so high a pressure.

§ 24. The temperature of our 40 kilometres deep lava ocean of melted diabase may therefore be taken as but little less than 1420° from surface to bottom. Its surface would radiate heat out into space at some such rate as two (gramme-water) thermal units Centigrade per square centimetre per second ‡. Thus, in a year (31½ million seconds)

* *Phil. Mag.* 1893, first half-year, p. 306.

† *Trans. Roy. Soc. Edinburgh*, Jan. 2, 1849; *Cambridge and Dublin Mathematical Journal*, Nov. 1850. Reprinted in *Math. and Phys. Papers* (Kelvin), vol. i. p. 156.

‡ This is a very rough estimate which I have formed from consideration of J. T. Bottomley's accurate determinations in absolute measure of thermal radiation at temperatures up to 920° C. from platinum wire and from polished and blackened surfaces of various kinds in receivers of air-pumps exhausted down to one ten-millionth of the atmospheric pressure, *Phil. Trans. Roy. Soc.*, 1887 and 1893.

63 million thermal units would be lost per square centimetre from the surface. This is, according to Carl Barus, very nearly equal to the latent heat of fusion abandoned by a million cubic centimetres of melted diabase in solidifying into the glassy condition (pitch-stone) which is assumed when the freezing takes place in the course of a few minutes. But, as found by Sir James Hall in his Edinburgh experiments * of 100 years ago, when more than a few minutes is taken for the freezing, the solid formed is not a glass but a heterogeneous crystalline solid of rough fracture; and if a few hours or days, or any longer time, is taken, the solid formed has the well known rough crystalline structure of basaltic rocks found in all parts of the world. Now Carl Barus finds that basaltic diabase is 14 per cent. denser than melted diabase, and 10 per cent. denser than the glass produced by quick freezing of the liquid. He gives no data, nor do Rücker and Roberts-Austen, who have also experimented on the thermodynamic properties of melted basalt, give any data, as to the latent heat evolved in the consolidation of liquid lava into rock of basaltic quality. Guessing it as three times the latent heat of fusion of the diabase pitch-stone, I estimate a million cubic centimetres of liquid frozen per square centimetre per centimetre per three years. This would diminish the depth of the liquid at the rate of a million centimetres per three years, or 40 kilometres in twelve years.

§ 25. Let us now consider in what manner this diminution of depth of the lava ocean must have proceeded, by the freezing of portions of it; all having been at temperatures very little below the assumed 1420° melting temperature of the bottom, when the depth was 40 kilometres. The loss of heat from the white-hot surface (temperatures from 1420° to perhaps 1380° in different parts) at our assumed rate of two (gramme-water Centigrade) thermal units per sq. cm. per sec. produces very rapid cooling of the liquid within a few centimetres of the surface (thermal capacity $\cdot 36$ per gramme, according to Barus) and in consequence great downward rushes of this cooled liquid, and upwards of hot liquid, spreading out horizontally in all directions when it reaches the surface. When the sinking liquid gets within perhaps 20 or 10 or 5 kilometres of the bottom, its temperature †

* Trans. Roy. Soc. Edinburgh.

† The temperature of the sinking liquid rock rises in virtue of the increasing pressure: but much less than does the freezing point of the liquid or of some of its ingredients. (See Kelvin, *Math. and Phys. Papers*, vol. iii. pp. 69, 70.)

becomes the freezing-point as raised by the increased pressure ; or, perhaps more correctly stated, a temperature at which some of its ingredients crystallize out of it. Hence, beginning a few kilometres above the bottom, we have a snow shower of solidified lava or of crystalline flakes, or prisms, or granules of felspar, mica, hornblende, quartz, and other ingredients : each little crystal gaining mass and falling somewhat faster than the descending liquid around it, till it reaches the bottom. This process goes on until, by the heaping of granules and crystals on the bottom, our lava ocean becomes silted up to the surface.

Probable Origin of Granite. (§§ 26, 27.)

§ 26. Upon the suppositions we have hitherto made we have, at the stage now reached, all round the earth at the same time a red hot or white hot surface of solid granules or crystals with interstices filled by the mother liquor still liquid, but ready to freeze with the slightest cooling. The thermal conductivity of this heterogeneous mass, even before the freezing of the liquid part, is probably nearly the same as that of ordinary solid granite or basalt at a red heat, which is almost certainly * somewhat less than the thermal conductivity of igneous rocks at ordinary temperatures. If you wish to see for yourselves how quickly it would cool when wholly solidified take a large macadamising stone, and heat it red hot in an ordinary coal fire. Take it out with a pair of tongs and leave it on the hearth, or on a stone slab at a distance from the fire, and you will see that in a minute or two, or perhaps in less than a minute, it cools to below red heat.

§ 27. Half an hour † after solidification reached up to the surface in any part of the earth, the mother liquor among the granules must have frozen to a depth of several centimetres below the surface and must have cemented together the granules and crystals, and so formed a crust of primeval granite, comparatively cool at its upper surface, and red hot to white hot, but still all solid, a little distance down ; becoming thicker and thicker very rapidly at first ; and after a few weeks certainly cold enough at its outer surface to be touched by the hand.

* Proc. R. S., May 30, 1895.

† Witness the rapid cooling of lava running red hot or white hot from a volcano, and after a few days or weeks presenting a black hard crust strong enough and cool enough to be walked over with impunity.

Probable Origin of Basaltic Rock *. (§§ 28, 29.)

§ 28. We have hitherto left, without much consideration, the mother liquor among the crystalline granules at all depths below the bottom of our shoaling lava ocean. It was probably this interstitial mother liquor that was destined to form the basaltic rock of future geological time. Whatever be the shapes and sizes of the solid granules when first falling to the bottom, they must have lain in loose heaps with a somewhat large proportion of space occupied by liquid among them. But, at considerable distances down in the heap, the weight of the superincumbent granules must tend to crush corners and edges into fine powder. If the snow shower had taken place in air we may feel pretty sure (even with the slight knowledge which we have of the hardnesses of the crystals of felspar, mica and hornblende, and of the solid granules of quartz) that, at a depth of 10 kilometres, enough of matter from the corners and edges of the granules of different kinds, would have been crushed into powder of various degrees of fineness, to leave an exceedingly small proportionate volume of air in the interstices between the solid fragments. But in reality the effective weight of each solid particle, buoyed as it was by hydrostatic pressure of a liquid less dense than itself by not more than 20 or 15 or 10 per cent., cannot have been more than from about one-fifth to one-tenth of its weight in air, and therefore the same degree of crushing effect as would have been experienced at 10 kilometres with air in the interstices, must have been experienced only at depths of from 50 to 100 kilometres below the bottom of the lava ocean.

§ 29. A result of this tremendous crushing together of the solid granules must have been to press out the liquid from among them, as water from a sponge, and cause it to pass upwards through the less and less closely packed heaps of solid particles, and out into the lava ocean above the heap. But, on account of the great resistance against the liquid permeating upwards 30 or 40 kilometres through interstices among the solid granules, this process must have gone on somewhat slowly; and, during all the time of the shoaling of the larva ocean, there may have been a considerable proportion of the whole volume occupied by the mother liquor among the solid granules, down to even as low as 50 or 100 kilometres below the top of the heap, or bottom of the ocean, at

* See Addendum at end of Lecture.

each instant. When consolidation reached the surface, the oozing upwards of the mother liquor must have been still going on to some degree. Thus, probably for a few years after the first consolidation at the surface, not probably for as long as one hundred years, the settlement of the solid structure by mere mechanical crushing of the corners and edges of solid granules, may have continued to cause the oozing upwards of mother liquor to the surface through cracks in the first formed granite crust and through fresh cracks in basaltic crust subsequently formed above it.

Leibnitz's Consistentior Status.

§ 30. When this oozing everywhere through fine cracks in the surface ceases, we have reached Leibnitz's *consistentior status*; beginning with the surface cool and permanently solid and the temperature increasing to 1150° C. at 25 or 50 or 100 metres below the surface.

Probable Origin of Continents and Ocean Depths of the Earth. (§§ 31-37.)

§ 31. If the shoaling of the lava ocean up to the surface had taken place everywhere at the same time, the whole surface of the consistent solid would be the dead level of the liquid lava all round, just before its depth became zero. On this supposition there seems no possibility that our present-day continents could have risen to their present heights, and that the surface of the solid in its other parts could have sunk down to their present ocean depths, during the twenty or twenty-five million years which may have passed since the *consistentior status* began or during any time however long. Rejecting the extremely improbable hypothesis that the continents were built up of meteoric matter tossed from without, upon the already solidified earth, we have no other possible alternative than that they are due to heterogeneousness in different parts of the liquid which constituted the earth before its solidification. The hydrostatic equilibrium of the rotating liquid involved only homogeneousness in respect to density over every level surface (that is to say, surface perpendicular to the resultant of gravity and centrifugal force): it required no homogeneousness in respect to chemical composition. Considering the almost certain truth that the earth was built up of meteorites falling together, we may follow in imagination the whole process of shrinking from gaseous nebula to liquid lava and metals, and solidification of liquid from central regions outwards, without finding any thorough mixing up of different ingredients, coming together from different directions

of space—any mixing up so thorough as to produce even approximately chemical homogeneousness throughout every layer of equal density. Thus we have no difficulty in understanding how even the gaseous nebula, which at one time constituted the matter of our present earth, had in itself a heterogeneousness from which followed by dynamical necessity Europe, Asia, Africa, America, Australia, Greenland, and the Antarctic Continent, and the Pacific, Atlantic, Indian, and Arctic Ocean depths, as we know them at present.

§ 32. We may reasonably believe that a very slight degree of chemical heterogeneousness could cause great differences in the heaviness of the snow shower of granules and crystals on different regions of the bottom of the lava ocean when still 50 or 100 kilometres deep. Thus we can quite see how it may have shoaled much more rapidly in some places than in others. It is also interesting to consider that the solid granules, falling on the bottom, may have been largely disturbed, blown as it were into ridges (like rippled sand in the bed of a flowing stream, or like dry sand blown into sand-hills by wind) by the eastward horizontal motion which liquid descending in the equatorial regions must acquire, relatively to the bottom, in virtue of the earth's rotation. It is indeed not improbable that this influence may have been largely effective in producing the general configuration of the great ridges of the Andes and Rocky Mountains and of the West Coasts of Europe and Africa. It seems, however, certain that the main determining cause of the continents and ocean-depths was chemical differences, perhaps very slight differences, of the material in different parts of the great lava ocean before consolidation.

§ 33. To fix our ideas let us now suppose that over some great areas such as those which have since become Asia, Europe, Africa, Australia, and America, the lava ocean had silted up to its surface, while in other parts there still were depths ranging down to 40 kilometres at the deepest. In a very short time, say about twelve years according to our former estimate (§ 24) the whole lava ocean becomes silted up to its surface.

§ 34. We have not time enough at present to think out all the complicated actions, hydrostatic and thermodynamic, which must accompany, and follow after, the cooling of the lava ocean surrounding our ideal primitive continent. By a hurried view, however, of the affair we see that in virtue of, let us say, 15 per cent. shrinkage by freezing, the level of the liquid must, at its greatest supposed depth, sink six kilometres relatively to the continents: and thus the liquid

must recede from them ; and their bounding coast-lines must become enlarged. And just as water runs out of a sandbank, drying when the sea recedes from it on a falling tide, so rivulets of the mother liquor must run out from the edges of the continents into the receding lava ocean. But, unlike sandbanks of incoherent sand permeated by water remaining liquid, our uncovered banks of white-hot solid crystals, with interstices full of the mother liquor, will, within a few hours of being uncovered, become crusted into hard rock by cooling at the surface, and freezing of the liquor, at a temperature somewhat lower than the melting temperatures of any of the crystals previously formed. The thickness of the wholly solidified crust grows at first with extreme rapidity, so that in the course of three or four days it may come to be as much as a metre. At the end of a year it may be as much as 10 metres ; with a surface, almost, or quite, cool enough for some kinds of vegetation. In the course of the first few weeks the regime of conduction of heat outwards becomes such that the thickness of the wholly solid crust, as long as it remains undisturbed, increases as the square root of the time ; so that in 100 years it becomes 10 times, in 25 million years 5000 times, as thick as it was at the end of one year ; thus, from one year to 25 million years after the time of surface freezing, the thickness of the wholly solid crust might grow from 10 metres to 50 kilometres. These definite numbers are given merely as an illustration ; but it is probable they are not enormously far from the truth in respect to what has happened under some of the least disturbed parts of the earth's surface.

§ 35. We have now reached the condition described above in § 30, with only this difference, that instead of the upper surface of the whole solidified crust being level we have in virtue of the assumptions of §§ 33, 34, inequalities of 6 kilometres from highest to lowest levels, or as much more than 6 kilometres as we please to assume it.

§ 36. There must still be a small, but important, proportion of mother liquor in the interstices between the closely packed uncooled crystals below the wholly solidified crust. This liquor, differing in chemical constitution from the crystals, has its freezing-point somewhat lower, perhaps very largely lower, than the lowest of their melting-points. But, when we consider the mode of formation (§ 25) of the crystals from the mother liquor, we must regard it as still always a solvent ready to dissolve, and to redeposit, portions of the crystalline matter, when slight variations of temperature or pressure tend to cause such actions. Now as the specific gravity of

the liquor is less, by something like 15 per cent., than the specific gravity of the solid crystals, it must *tend* to find its way upwards, and will actually do so, however slowly, until stopped by the already solidified impermeable crust, or until itself becomes solid on account of loss of heat by conduction outwards. If the upper crust were everywhere continuous and perfectly rigid the mother liquor must, inevitably, if sufficient time be given, find its way to the highest places of the lower boundary of the crust, and there form gigantic pockets of liquid lava tending to break the crust above it and burst up through it.

§ 37. But in reality the upper crust cannot have been infinitely strong; and, judging alone from what we know of properties of matter, we should expect gigantic cracks to occur from time to time in the upper crust tending to shrink as it cools and prevented from lateral shrinkage by the non-shrinking uncooled solid below it. When any such crack extends downwards as far as a pocket of mother liquor underlying the wholly solidified crust, we should have an outburst of trap rock or of volcanic lava just such as have been discovered by geologists in great abundance in many parts of the world. We might even have comparatively small portions of high plateaus of the primitive solid earth raised still higher by outbursts of the mother liquor squeezed out from below them in virtue of the pressure of large surrounding portions of the superincumbent crust. In any such action, due to purely gravitational energy, the centre of gravity of all the material concerned must sink, although portions of the matter may be raised to greater heights; but we must leave these large questions of geological dynamics, having been only brought to think of them at all just now by our consideration of the earth, antecedent to life upon it.

§ 38. The temperature to which the earth's surface cooled within a few years after the solidification reached it, must have been, as it is now, such that the temperature at which heat radiated into space during the night exceeds that received from the sun during the day, by the small difference due to heat conducted outwards from within*. One year

* Suppose, for example, the cooling and thickening of the upper crust has proceeded so far, that at the surface and therefore approximately for a few decimetres below the surface, the rate of augmentation of temperature downwards is one degree per centimetre. Taking as a rough average '005 C.G.S. as the thermal conductivity of the surface rock, we should have for the heat conducted outwards '005 of a gramme water thermal unit centigrade per sq. cm. per sec. (Kelvin, *Math. and Phys. Papers*, vol. iii. p. 226). Hence if (*ibid.* p. 223) we take $\frac{1}{8000}$ as the

after the freezing of the granitic interstitial mother liquor at the earth's surface in any locality, the average temperature at the surface might be warmer, by 60° or 80° Cent., than if the whole interior had the same average temperature as the surface. To fix our ideas, let us suppose, at the end of one year, the surface to be 80° warmer than it would be with no underground heat: then at the end of 100 years it would be 8° warmer, and at the end of 10,000 years it would be $\cdot 8$ of a degree warmer, and at the end of 25 million years it would be $\cdot 016$ of a degree warmer, than if there were no underground heat.

§ 39. When the surface of the earth was still white-hot liquid all round, at a temperature fallen to about 1200° Cent., there must have been hot gases and vapour of water above it in all parts, and possibly vapours of some of the more volatile of the present known terrestrial solids and liquids, such as zinc, mercury, sulphur, phosphorus. The very rapid cooling which followed instantly on the solidification at the surface must have caused a rapid downpour of all the vapours other than water, if any there were; and a little later, rain of water out of the air, as the temperature of the surface cooled from red heat to such moderate temperatures as 40° and 20° and 10° Cent., above the average due to sun heat and radiation into the æther around the earth. What that primitive atmosphere was, and how much rain of water fell on the earth in the course of the first century after consolidation, we cannot tell for certain; but Natural History and Natural Philosophy give us some foundation for endeavours to discover much towards answering the great questions,—Whence came our present atmosphere of nitrogen, oxygen, and carbonic acid? Whence came our present oceans and lakes of salt and fresh water? How near an approximation

radiational emissivity of rock and atmosphere of gases and watery vapour above it radiating heat into the surrounding vacuous space (æther), we find $8000 \times \cdot 005$, or 40 degrees Cent. as the excess of the mean surface temperature above what it would be if no heat were conducted from within outwards. The present augmentation of temperature downwards may be taken as 1 degree Cent. per 27 metres as a rough average derived from observations in all parts of the earth where underground temperature has been observed. (See British Association Reports from 1868 to 1895. The very valuable work of this Committee has been carried on for these twenty-seven years with great skill, perseverance, and success, by Professor Everett, and he promises a continuation of his reports from time to time.) This with the same data for conductivity and radiational emissivity as in the preceding calculation makes $40^{\circ}/2700$ or $0\cdot 0148^{\circ}$ Cent. per centimetre as the amount by which the average temperature of the earth's surface is at present kept up by underground heat.

to present conditions was realized in the first hundred centuries after consolidation of the surface?

§ 40. We may consider it as quite certain that nitrogen gas, carbonic acid gas, and steam, escaped abundantly in bubbles from the mother liquor of granite, before the primitive consolidation of the surface, and from the mother liquor squeezed up from below in subsequent eruptions of basaltic rock; because all, or nearly all, specimens of granite and basaltic rock, which have been tested by chemists in respect to this question*, have been found to contain, condensed in minute cavities within them, large quantities of nitrogen, carbonic acid, and water. It seems that in no specimen of granite or basalt tested has chemically free oxygen been discovered, while in many, chemically free hydrogen has been found; and either native iron or magnetic oxide of iron in those which do not contain hydrogen. From this it might seem probable that there was no free oxygen in the primitive atmosphere, and that if there was free hydrogen, it was due to the decomposition of steam by iron or magnetic oxide of iron. Going back to still earlier conditions we might judge that, probably, among the dissolved gases of the hot nebula which became the earth, the oxygen all fell into combination with hydrogen and other metallic vapours in the cooling of the nebula, and that although it is known to be the most abundant material of all the chemical elements constituting the earth, none of it was left out of combination with other elements to give free oxygen in our primitive atmosphere.

§ 41. It is, however, possible, although it might seem not probable, that there was free oxygen in the primitive atmosphere. With or without free oxygen, however, *but with sunlight*, we may regard the earth as fitted for vegetable life as now known in some species, wherever water moistened the newly solidified rocky crust cooled down below the temperature of 80° or 70° of our present Centigrade thermometric scale, a year or two after solidification of the primitive lava had come up to the surface. The thick tough velvety coating of living vegetable matter, covering the rocky slopes under hot water flowing direct out of the earth at Banff (Canada) †, lives without help from any ingredients of the atmosphere above it, and takes from the water and from carbonic acid or carbonates, dissolved in it, the hydrogen and carbon needed for its own growth by the dynamical power of sunlight; thus

* See, for example, Tilden, Proc. R. S. February 4th, 1897. "On the Gases enclosed in Crystalline Rocks and Minerals."

† Rocky Mountains Park of Canada, on the Canadian Pacific Railway.

leaving free oxygen in the water to pass ultimately into the air. Similar vegetation is found abundantly on the terraces of the Mammoth hot springs and on the beds of the hot water streams flowing from the Geysers in the Yellowstone National Park of the United States. This vegetation, consisting of confervæ, all grows under flowing water at various temperatures, some said to be as high as 74° Cent. We cannot doubt but that some such confervæ, if sown or planted in a rivulet or pool of warm water in the early years of the first century of the solid earth's history, and if favoured with sunlight, would have lived, and grown, and multiplied, and would have made a beginning of oxygen in the air, if there had been none of it before their contributions. Before the end of the century, if sun-heat, and sunlight, and rainfall, were suitable, the whole earth not under water must have been fitted for all kinds of land plants which do not require much or any oxygen in the air, and which can find, or make, place and soil for their roots on the rocks on which they grow; and the lakes or oceans formed by that time must have been quite fitted for the life of many or all of the species of water plants living on the earth at the present time. The moderate warming, both of land and water, by underground heat, towards the end of the century, would probably be favourable rather than adverse to vegetation, and there can be no doubt but that if abundance of seeds of all species of the present day had been scattered over the earth at that time, an important proportion of them would have lived and multiplied by natural selection of the places where they could best thrive.

§ 42. But if there was no free oxygen in the primitive atmosphere or primitive water, several thousands, possibly hundreds of thousands, of years must pass before oxygen enough for supporting animal life, as we now know it, was produced. Even if the average activity of vegetable growth on land and in water over the whole earth was, in those early times, as great in respect to evolution of oxygen as that of a Hessian forest, as estimated by Liebig* 50 years ago, or of a cultivated English hayfield of the present day, a very improbable supposition, and if there were no decay (*eremacausis*, or gradual recombination with oxygen) of the plants or of portions such as leaves falling from plants, the rate of evolution of oxygen, reckoned as three times the weight of the wood or the dry hay produced, would be only about

* Liebig, 'Chemistry in its application to Agriculture and Physiology,' English, 2nd ed., edited by Playfair, 1842.

6 tons per English acre per annum or $1\frac{1}{2}$ tons per square metre per thousand years. At this rate it would take only 1533 years, and therefore in reality a much longer time would almost certainly be required, to produce the 2·3 tons of oxygen which we have at present resting on every square metre of the earth's surface, land and sea*. But probably quite a moderate number of hundred thousand years may have sufficed. It is interesting at all events to remark that, at any time, the total amount of combustible material on the earth, in the form of living plants or their remains left dead, must have been just so much that to burn it all would take either the whole oxygen of the atmosphere, or the excess of oxygen in the atmosphere at the time, above that, if any, which there was in the beginning. This we can safely say, because we almost certainly neglect nothing considerable in comparison with what we assert when we say that the free oxygen of the earth's atmosphere is augmented only by vegetation liberating it from carbonic acid and water, in virtue of the power of sunlight, and is diminished only by virtual burning† of the vegetable matter thus produced. But it seems improbable that the average of the whole earth—dry land and sea-bottom—contains at present coal, or wood, or oil, or fuel of any kind originating in vegetation, to so great an amount as ·767 of a ton per square metre of surface; which is the amount at the rate of one ton of fuel to three tons of oxygen, that would be required to produce the 2·3 tons of oxygen per square metre of surface, which our present atmosphere contains. Hence it seems probable that the earth's primitive atmosphere must have contained free oxygen.

§ 43. Whatever may have been the true history of our atmosphere it seems certain that if sunlight was ready, the earth was ready, both for vegetable and animal life, if not within a century, at all events within a few hundred centuries after the rocky consolidation of its surface. But was the sun ready? The well founded dynamical theory of the sun's heat carefully worked out and discussed by Helmholtz,

* In our present atmosphere, in average conditions of barometer and thermometer we have, resting on each square metre of the earth's surface, ten tons total weight, of which 7·7 is nitrogen and 2·3 is oxygen.

† This "virtual burning" includes eremacausis of decay of vegetable matter, if there is any eremacausis of decay without the intervention of microbes or other animals. It also includes the combination of a portion of the food with inhaled oxygen in the regular animal economy of provision for heat and power.

Newcomb, and myself *, says NO if the consolidation of the earth took place as long ago as 50 million years ; the solid earth must in that case have waited 20 or 50 million years for the sun to be anything nearly as warm as he is at present. If the consolidation of the earth was finished 20 or 25 million years ago, the sun was probably ready,—though probably not then quite so warm as at present, yet warm enough to support some kind of vegetable and animal life on the earth.

§ 44. My task has been rigorously confined to what, humanly speaking, we may call the fortuitous concourse of atoms, in the preparation of the earth as an abode fitted for life, except in so far as I have referred to vegetation, as possibly having been concerned in the preparation of an atmosphere suitable for animal life as we now have it. Mathematics and dynamics fail us when we contemplate the earth, fitted for life but lifeless, and try to imagine the commencement of life upon it. This certainly did not take place by any action of chemistry, or electricity, or crystalline grouping of molecules under the influence of force, or by any possible kind of fortuitous concourse of atoms. We must pause, face to face with the mystery and miracle of the creation of living creatures.

ADDENDUM.—*May* 1898.

Since this lecture was delivered I have received from Professor Roberts-Austen the following results of experiments on the melting-points of rocks which he has kindly made at my request:—

	Melting-point.	Error.
Felspar . . .	1520° C.	± 30°
Hornblende . about	1400°	
Mica . . .	1440°	± 30°
Quartz . . .	1775°	± 15°
Basalt . . . about	880°	

These results are in conformity with what I have said in §§ 26–28 on the probable origin of granite and basalt, as they show that basalt melts at a much lower temperature than felspar, hornblende, mica, or quartz, the crystalline ingredients of granite. In the electrolytic process for producing aluminium, now practised by the British Aluminium

* See 'Popular Lectures and Addresses,' vol. i. pp. 376–429, particularly page 397.

Company at their Foyers works, alumina, of which the melting-point is certainly above 1700° C. or 1800° C., is dissolved in a bath of melted cryolite at a temperature of about 800° C. So we may imagine melted basalt to be a solvent for felspar, hornblende, mica, and quartz at temperatures much below their own separate melting-points; and we can understand how the basaltic rocks of the earth may have resulted from the solidification of the mother liquor from which the crystalline ingredients of granite have been deposited.

VI. *On the Rate of Explosion in Gases.*

By D. L. CHAPMAN, B.A. (Oxon.)*

THE object of the investigation of which an account is given in this paper is the discovery of formulæ to express the maximum rates of explosion in gases and the maximum pressure in the explosive wave.

The data which I propose to use are taken almost entirely from the Bakerian Lecture of 1893, on "The Rates of Explosion in Gases," by Prof. Dixon. The maximum velocities of explosion given below are in all cases those measured by Prof. Dixon or under his direction. Experimental conclusions only will be quoted; for a complete account of the experiments themselves, the reader is referred to the above-mentioned paper, and to several papers which were subsequently published in the 'Journal of the Manchester Literary and Philosophical Society' and in the 'Journal of the Chemical Society.'

Ignoring for the present all minor details connected with particular cases, which may be more conveniently discussed at a later stage, it is sufficient for our purpose to state at the outset that it has been established that the maximum velocity of explosion, in a mixture of definite composition and at fixed temperature and pressure, has a definite value, independent of the diameter of the tube when that diameter exceeds a certain limit. The relations existing between temperature and pressure and the velocity of explosion are such that an increase of temperature causes a fall in the velocity, whereas an increase of pressure has the reverse effect up to a certain limit, beyond which the velocity remains constant.

For the suggestion that an explosion is in its character essentially similar to a sound-wave, we are also indebted to Prof. Dixon; and there is little doubt that all subsequent advance must be made with this suggestion as the leading

* Communicated by Prof. Dixon, F.R.S.

idea*. Although Prof. Dixon's sound-wave formula has yielded such excellent results, he has pointed out the necessity of further *à priori* work in the subject.

The Rate of Explosion for an Infinite Plane Wave.

In the following attempt to establish a formula for the velocity of explosion, I have made certain assumptions which have not as yet received sufficient experimental confirmation; but they are, I think, justified by the results. For instance, it is assumed that, once the maximum velocity is reached, the front of the explosion wave is of such a character that we may suppose steady motion. This, as Prof. Schuster has pointed out in a note to the Bakerian Lecture, is not an impossibility when chemical change is taking place, since the implied relation between pressure and density is possible under such circumstances. This point, however, requires further investigation. The wave is assumed to be an infinite plane wave. This assumption is justified by the fact that the diameter of the tube is without influence on the found velocity. I propose to limit the term "explosive wave" to the space within which chemical change is taking place. This space is bounded by two infinite planes. On either side of the wave are the exploded and unexploded gases, which are assumed to have uniform densities and velocities. The statement that the exploded gas possesses uniform density and velocity for some distance behind the wave requires further justification, which can only be imperfectly given after a discussion of the general problem.

How the true explosive wave is actually generated in practice is a question without the scope of the present investigation. In order to avoid the discussion of this point, I shall substitute for it a physical conception, which, although unrealizable in practice, will render aid in illustrating the views here advanced.

Let us suppose that the gas is enclosed in an infinite cylinder ABCD, provided with a piston E, and that the explosive wave XYZS has just started. The initial velocity of this wave will be small; the initial pressure along the plane XS will also be small compared with that ultimately attained. As the wave proceeds in the direction AB, the piston E is supposed to follow it in such a manner that

* In the earlier researches Berthelot's theory was accepted as a working hypothesis. It was only after the difficulties attending the measurement of the rates of explosion in mixtures containing inert gases had been overcome that the inadequacy of Berthelot's theory became evident and the superiority of the sound-wave theory could be demonstrated.

the pressure at EF is always kept equal to the pressure at XS. During this process the velocity of the wave will gradually increase, until ultimately its velocity will be uniform, its type constant, and the exploded gas within the area EXSF homogeneous. It is this ultimate steady

Fig. 1.

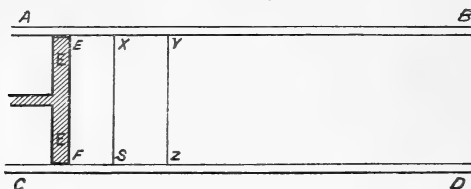

state alone which I propose to consider. During the process just described the velocity will of course constantly increase until it attains a maximum. After the velocity has become uniform, and the wave permanent in type, it is obvious that another permanent state may be reached in the following way:—Suppose a piston is introduced immediately behind the permanent wave, and that this piston is made to move forward more rapidly than the previous one, the pressure and density behind the wave will thus be increased, and after a certain period of time another *steady* state will be reached. All this is equivalent to the statement that the *permanent* velocity of explosion is a function of the density of the exploded gas.

I shall now proceed to prove the latter statement.

Since the discussion is limited to the wave of permanent type, we may write down the condition of steady motion,

$$\frac{u}{v} = \frac{V}{v_0}, \quad \dots \dots \dots (1)$$

where V and u are the velocities of the unexploded and exploded gas respectively, referred to coordinates moving with a velocity $-V$, and v_0 and v are the volumes of a gram-equivalent of the unexploded and exploded gas.

Take as an example cyanogen and oxygen, the explosion of which is represented by the equation

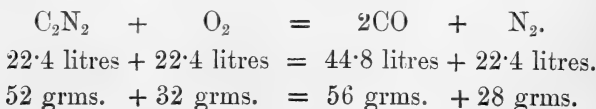

Here $v_0 = 44.8$ litres, and v is the volume of carbon monoxide

and nitrogen obtained from this immediately after the explosion.

μ = gram-equivalent (in this case, 84 grms.).

From (1) and the equations of motion, we obtain

$$p - p_0 = \frac{\mu V^2}{v_0^2} (v_0 - v). \quad \dots \dots (2)^*$$

This formula of Riemann assumes a relation to subsist between V , p , and v at all points of the wave; and from it the work performed by the wave during explosion may be calculated.

Work performed by the gas

$$\begin{aligned} &= \int_{v_0}^v p \, dv = \frac{\mu V^2}{v_0} \int_{v_0}^v (v_0 - v) \, dv + \int_{v_0}^v p_0 \, dv \\ &= -\frac{\mu V^2}{2v_0} (v - v_0)^2 + p_0(v - v_0). \end{aligned}$$

For the purpose of testing this result, it may be shown that the external work performed by the piston (fig. 1) is equal to the work performed on the gas together with the gain of kinetic energy.

The work performed on the gas

$$= \frac{\mu V^2}{2v_0^2} (v - v_0)^2 + p_0(v_0 - v).$$

The gain of kinetic energy

$$\begin{aligned} &= \frac{(V - u)^2 \mu}{2} \\ &= \frac{\mu V^2}{2v_0^2} (v_0 - v)^2, \quad \text{since } u = \frac{Vv}{v_0}. \end{aligned}$$

The external work performed by the piston

$$\begin{aligned} &= p(v_0 - v) \\ &= \frac{\mu V^2}{v_0^2} (v_0 - v)^2 + p_0(v_0 - v). \end{aligned}$$

\therefore External work performed by the piston

= gain of kinetic energy + work performed on the gas.

Assume that in the explosion n molecules become m molecules. For example, in the explosion of equal volumes of

* Rayleigh's 'Sound,' vol. ii.; Schuster's note in the Bakerian Lecture on Explosions.

cyanogen and oxygen, n is 2 and m is 3 :



I shall now calculate the energy lost when a gas is allowed to burn and the products of combustion are collected at the normal temperature and pressure.

Assume that one of the gases is enclosed in the cylinder A and the other in the cylinder B (fig. 2). These gases are forced

Fig. 2.

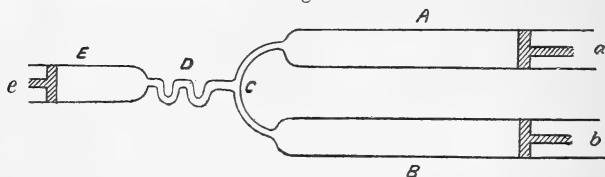

out, burned at C, cooled at D, and collected in the cylinder E. The gain of energy is the work performed by the pistons a and b ; and the loss of energy is the heat evolved at D, together with the work performed on the piston e . The total energy lost is the difference of these. The volume of gas in A and B is v_0 ; therefore the work performed by the pistons a and b is p_0v_0 . The volume of burnt gas is $\frac{mv_0}{n}$; and therefore the work performed on the piston e is $\frac{mp_0v_0}{n}$.

The heat evolved at D is the heat of combustion at constant pressure; call it h . Let the total energy lost = H .

Then

$$H = h + p_0v_0 \left(\frac{m}{n} - 1 \right).$$

During an explosion the whole of this energy is retained by the gas, and in addition to this it gains an amount of energy equal to the work performed on the gas.

The energy of the exploded gas is therefore given by the expression

$$\begin{aligned} & h + p_0v_0 \left(\frac{m}{n} - 1 \right) + \frac{\mu V^2}{2v_0^2} (v - v_0)^2 - p_0(v - v_0) \\ & \quad + \text{energy of exploded gas at N.T.P.} \\ & = h + \frac{\mu V^2}{2v_0^2} (v - v_0)^2 - p_0v + p_0v_0 \frac{m}{n} + \text{energy at N.T.P.} \end{aligned}$$

If t_0 is the normal temperature, and t the temperature of the gas after explosion,

$mC_v(t-t_0) + \text{energy at N.T.P.} = \text{energy of exploded gas};$

$$\therefore mC_v(t-t_0) = h + \frac{\mu V^2}{2v_0^2}(v-v_0)^2 - p_0v + p_0v_0 \frac{m}{n};$$

$$\therefore t = \frac{h + \frac{\mu V^2}{2v_0^2}(v-v_0)^2 - p_0v + p_0v_0 \frac{m}{n}}{mC_v} + t_0. \quad (3)$$

But $pv = mRt$,

$$\therefore pv = \frac{R}{C_v} \left\{ h + \frac{\mu V^2}{2v_0^2}(v-v_0)^2 - p_0v + p_0v_0 \frac{m}{n} \right\} + mRt_0.$$

Also, from equation (2), we get

$$pv = \frac{\mu V^2}{v_0^2}(v_0-v)v + p_0v;$$

$$\begin{aligned} \therefore \frac{R}{C_v} \left\{ h + \frac{\mu V^2}{2v_0^2}(v-v_0)^2 - p_0v + p_0v_0 \frac{m}{n} \right\} + mRt_0 \\ = \frac{\mu V^2}{v_0^2}(v_0-v)v + p_0v. \quad (4) \end{aligned}$$

This establishes a relation between V and v . The velocity of a permanent explosion is therefore a function of the density of the exploded gas.

When an explosion starts its character and velocity are continually changing until it becomes a wave permanent in type and of uniform velocity. I think it is reasonable to assume that this wave—*i. e.* the wave of which the velocity has been measured by Prof. Dixon—is that steady wave which possesses minimum velocity; for, once it has become a permanent wave with uniform velocity, no reason can be discovered for its changing to another permanent wave having a greater uniform velocity and a greater maximum pressure.

This particular velocity may be discovered by eliminating v from the equations

$$V = f(v)$$

and

$$0 = \frac{dV}{dv}.$$

It may be well to point out that under these circumstances the entropy of the exploded gas is a maximum. This may be easily shown thus :—

The condition for maximum entropy is

$$0 = d\phi = mC_v \frac{dt}{t} + \frac{p}{t} dv ;$$

$$\therefore mC_v dt = -p dv,$$

or

$$\frac{dt}{dv} = -\frac{p}{mC_v} \dots \dots \dots (\alpha)$$

By differentiating (3),

$$\frac{dt}{dv} = \frac{1}{mC_v} \left\{ \frac{\mu V}{v_0^2} (v-v_0)^2 \frac{dV}{dv} + \frac{\mu V^2}{v_0^2} (v-v_0) - p_0 \right\} ;$$

but from (α) and Riemann's equation

$$\frac{dt}{dv} = -\frac{1}{mC_v} \left\{ \frac{\mu V^2}{v_0} (v_0-v) + p_0 \right\} ;$$

$$\therefore \frac{dV}{dv} = 0;$$

therefore the condition of minimum velocity is equivalent to the condition of maximum entropy*.

The following method of arriving at the approximation $v = \frac{C_p}{C_p + C_v} v_0$ was suggested by Prof. Schuster, who has shown that the method by which I arrived at the same result is inconclusive.

Equation (4) arranged differently runs

$$\frac{R\mu V^2(v-v_0)^2}{2C_v v_0^2} + \frac{\mu V^2}{v_0^2} (v-v_0)v = p_0 v \left[1 + \frac{R}{C_v} \right] - H,$$

where H does not contain v.

Or putting $R = C_p - C_v$,

$$\frac{\mu V^2(v-v_0)}{v_0^2} \left[\frac{C_p - C_v}{2C_v} (v-v_0) + v \right] = p_0 v \frac{C_p}{C_v} - H ;$$

$$\therefore \frac{\mu V^2}{v_0^2} = \frac{H - p_0 v \frac{C_p}{C_v}}{(v-v_0) \left[\frac{C_p - C_v}{2C_v} v_0 - \frac{C_p + C_v}{2C_v} v \right]}.$$

The complete expression $\frac{dV}{dv} = 0$ leads to a quadratic expression for v. Hence there are two minima or maxima.

* In any adiabatic change the entropy cannot decrease, and therefore it tends to become a maximum.

If

$$v = v_0, \quad V^2 = \infty,$$

$$v = \frac{C_p - C_v}{C_p + C_v} v_0, \quad V^2 = \infty.$$

Hence one minimum lies between these values*.

If H is large compared to $p_0 v \frac{C_p}{C_v}$, V will be a minimum or maximum when

$$(v - v_0) \left[\frac{C_p - C_v}{2C_v} v_0 - \frac{C_p + C_v}{2C_v} v \right]$$

is a maximum or minimum.

Writing this F: F will be zero for

$$v = v_0,$$

$$v = \frac{C_p - C_v}{C_p + C_v} v_0.$$

For $v = \pm \infty$ it will be negative; hence between the above values of v there will be a maximum of F or a minimum of V.

Also

$$2C_v \frac{dF}{dv} = (C_p - C_v)v_0 - (C_p + C)v - (v - v_0)(C_p + C_v)$$

$$= 2C_p v_0 - 2(C_p + C)v.$$

And $\frac{d^2F}{dv^2}$ is always negative; hence F must be a maximum when

$$v = \frac{C_p}{C_p + C_v} v_0. \quad \dots \dots \dots (5)$$

By eliminating v from (4) and (5) we obtain the value of V^2 . This elimination leads to the result

$$V^2 = \frac{2p_0 v_0 C_p}{n\mu C_v^2} \{ (m - n)C_p + mC_v \} + \frac{2(C_p + C_v)R h}{\mu C_v^2}$$

$$= \frac{2R}{\mu C_v^2} [\{ (m - n)C_p + mC_v \} C_p t_0 + (C_p + C_v)h],$$

since $p_0 v_0 = nRt_0$.

It is assumed throughout that the exploded gas behind the wave remains at constant temperature and pressure, and has

* The other value of v obtained from the quadratic equation $\frac{dV}{dv} = 0$ is much larger than v_0 , and gives to V a very small value. It has therefore no connexion with the wave we are considering.

a uniform velocity. Therefore during the explosion momentum is generated by the moving piston. In an actual explosion in a tube not provided with a piston the whole mass of gas cannot move forward with this uniform velocity, for there would then be a vacuum at the end of the tube where the explosion started, and the pressure at that end would be zero, making it impossible to account for the generation of momentum. There is, however, no need to assume that the whole exploded gas acquires a uniform velocity. In fact the velocity of the wave would be the same if it were followed by a *layer* of exploded gas of uniform density and velocity, and would be unaffected by any subsequent disturbance which must take place behind the explosive wave.

It is therefore necessary to prove that behind the explosive wave there is a layer of homogeneous gas. *This evidently must be if any disturbance behind the wave can only move forward with a velocity less than that of the wave itself.*

The forward velocity of any disturbance in the exploded gas will be given by the sum of the velocity of the gas and the velocity of sound in the gas.

The velocity of the gas

$$\begin{aligned} &= V - u = V \left(1 - \frac{v}{v_0} \right) \\ &= V \left(\frac{C_v}{C_p + C_v} \right). \end{aligned}$$

The velocity of sound

$$= \sqrt{\frac{mRt}{\mu} \frac{C_p}{C_v}}.$$

In the complete expression for V^2 the first term may be here neglected. Also in the complete expression for t (equation (3)) the last three terms are small. We may therefore write

$$V^2 \doteq \frac{2R(C_p + C_v)h}{\mu C_v^2},$$

and

$$t \doteq \frac{h + \frac{\mu V^2}{2v_0^2} (v - v_0)^2}{mC}.$$

Employing these values, the velocity of the gas becomes

$$\sqrt{\frac{2Rh}{\mu} \left(\frac{1}{C_p + C} \right)},$$

and the velocity of sound

$$\sqrt{\frac{2Rh}{\mu} \left(\frac{C_p^2}{C_v^2(C_p + C_v)} \right)};$$

∴ the velocity of sound + velocity of the gas

$$= \sqrt{\frac{2Rh}{\mu} \cdot \frac{C_p^2 + C_v^2}{C_v^2(C_p + C_v)}}.$$

The velocity of explosion

$$= \sqrt{\frac{2Rh}{\mu} \frac{(C_p + C_v)^2}{C_v^2(C_p + C_v)}}.$$

The latter is evidently greater than the former. Therefore the layer of uniform gas behind the wave will gradually become greater as the explosion proceeds.

Calculation of the Rates of Explosion.

In attempting to calculate the rates of explosion from the formula there is some doubt as to what value should be adopted for the specific heat at constant volume. This constant has only been directly found at comparatively low temperatures. MM. Berthelot, Le Chatelier, and Mallard have made attempts to find the specific heats of the elementary gases and of carbon monoxide at high temperatures by measuring the pressure of explosion. Berthelot arrives at the conclusion that the specific heat at constant volume increases with the temperature, and at 4400° C. attains the value 9.6. M. Berthelot's experiments do not, however, agree with those of MM. Le Chatelier and Mallard, and two series of experiments conducted by the latter experimenters do not agree with one another. The specific heat at constant volume may, however, be calculated from the velocity of explosion with the aid of the proposed formula. A few explosions have therefore been selected and the specific heats and temperatures calculated from them; specific heats at intermediate temperatures being found by interpolation. It was immediately perceived that the specific heats of O₂, H₂, N₂, and CO might for all practical purposes be taken as identical at all temperatures.

A few words are necessary regarding explosions in which water is formed. If the specific heat of steam is taken as $\frac{3}{2}$ × specific heat of the diatomic gases, the found rates of explosion fall below the calculated rates when the dilution with inert gas is great, and *vice versa* when the dilution is small. It is possible to account for this by two theories. The first theory is that at high temperatures the water is dissociated, whereas at low temperatures the combination of hydrogen and oxygen is complete. The second theory is that the specific heat

TABLE I.
 $x^2 \left\{ \frac{V^2 \mu}{2Rj} - (2m - n)t_0 \right\} - 2x \{ h + t_0(3m - 2n) \} - 2 \{ h + 2t_0(m - n) \}.$

Mixture.	Equation.	x .	App. temp. ° C.	Specific heat of H ₂ O.	
2H ₂ + 2O ₂ = 2H ₂ O + O ₂	21,654 x^2 - 234,572 x - 232,856	11.748	3606	A. 13.807	
2H ₂ + 4O ₂ = 2H ₂ O + 3O ₂	28,417 x^2 - 235,716 x - 232,856	9.186	2833	B. 11.646	
2H ₂ + 6O ₂ = 2H ₂ O + 5O ₂	32,728 x^2 - 236,860 x - 232,856	8.114	2340	C. 9.672	
2H ₂ + O ₂ + N ₂ = 2H ₂ O + N ₂	22,145 x^2 - 234,572 x - 232,856	11.506	3675	A. 13.113	
4H ₂ + O ₂ = 2H ₂ O + 2H ₂	24,906 x^2 - 235,144 x - 232,856	10.345	3113	13.440	
2H ₂ + O ₂ + 3N ₂ = 2H ₂ O + 3N ₂	29,420 x^2 - 235,716 x - 232,856	8.904	2914	B. 10.928	
2H ₂ + O ₂ + 5N ₂ = 2H ₂ O + 5N ₂	33,521 x^2 - 236,860 x - 232,856	7.941	2391	C. 9.051	
6H ₂ + O ₂ = 2H ₂ O + 4H ₂	31,581 x^2 - 236,288 x - 232,856	8.364	2617		
8H ₂ + O ₂ = 2H ₂ O + 6H ₂	34,112 x^2 - 237,432 x - 232,856	7.832	2153	D. 8.915	
Mixture.	Equation.	x .	App. temp. ° C.	μ .	H.
C ₂ N ₂ + O ₂ = 2CO + N ₂	36,557 x^2 - 254,860 x - 253,144	7.653	5634	84	} 126,000
C ₂ N ₂ + 3O ₂ = 2CO + N ₂ + 2O ₂	38,023 x^2 - 256,004 x - 253,144	7.608	3598	148	
C ₂ N ₂ + 2N ₂ O = 2CO + 3N ₂	48,845 x^2 - 327,432 x - 325,288	7.571	4552	140	} 161,500
C ₂ N ₂ + 2N ₂ O + N ₂ = 2CO + 4N ₂	50,521 x^2 - 328,720 x - 325,288	7.379	3933	168	
C ₂ H ₄ + O ₂ = 2CO + 2H ₂	21,027 x^2 - 139,776 x - 137,488	7.517	2534	60	67,600
2H ₂ + O ₂ = 2H ₂ O	16,992 x^2 - 234,000 x - 232,856	14.703	4265	36	234,000
C ₂ N ₂ + O ₂ + 2N ₂ = 2CO + 3N ₂	37,787 x^2 - 256,004 x - 253,144	7.651	3841	140	126,000
C ₂ N ₂ + 2N ₂ O + 2N ₂ = 2CO + 5N ₂	49,456 x^2 - 329,292 x - 325,288	7.531	3349	196	161,500

of steam rises more rapidly with the temperature than the specific heat of the diatomic gas. The theory of dissociation is rendered improbable by the fact that dilution of electrolytic gas with oxygen lowers the rates a little more than dilution with an equal volume of nitrogen. The adoption of such an hypothesis would render it necessary for us to suppose that the chemical reaction does not proceed to its limit. Moreover, it would make it difficult to calculate the rates whenever steam is formed, for it would then be impossible, with our present knowledge, to say how far the chemical reaction would proceed in any particular case. We are therefore encouraged to test the first theory, *i. e.* that the specific heat of steam rises more rapidly with the temperature than that of the diatomic gases. The specific heat of steam at different temperatures has therefore been calculated from a few selected rates, as in the case of the elementary gases; and the values thus found are used to calculate the other rates. The results are given below. (Table II.)

TABLE II.—Specific Heats at Different Temperatures.
 w = specific heat of water. g = specific heat of diatomic gases.

$t.$	5600.	5500.	5400.	5300.	5200.	5100.	5000.	4900.	4800.
w
g	7·850	7·839	7·828	7·817	7·806	7·795	7·784	7·773	7·762
$t.$	4700.	4600.	4500.	4400.	4300.	4200.	4100.	4000.	3900.
w	14·750	14·625	14·467	14·297	14·125
g	7·751	7·740	7·729	7·718	7·707	7·696	7·685	7·674	7·663
$t.$	3800.	3700.	3600.	3500.	3400.	3300.	3200.	3100.	3000.
w	13·938	13·750	13·547	13·344	13·102	12·850	12·560	12·250	11·891
g	7·652	7·641	7·630	7·619	7·608	7·597	7·586	7·575	7·564
$t.$	2900.	2800.	2700.	2600.	2500.	2400.	2300.	2200.	2100.
w	11·503	11·040	10·578	10·172	9·797	9·484	9·203	9·000	8·828
g	7·553	7·542	7·531	7·520	7·509	7·498	7·487	7·476	7·465

TABLE III.

Velocity of Explosion calculated from the Formula

$$V^2 = \frac{2R_j}{\mu C_v} \left[\{ (m-n)C_p + mC_v \} C_p t_0 + (C_p + C_v)h \right].$$

A is the 1st term in the expression for V^2 . Ch is the second term.

Mixture.	μ .	Ch.	A.	V.	Found.	t .	Mean C_p .	Remarks.
$7H_2 + 2N_2O = 2H_2O + 2N_2 + 5H_2$	102	2,731,000	203,610	2746	2732	2418	7.954	Heat of combustion = 152,500. Heat of combustion = 303,452. " " = 204,976. " " = 117,000.
$6H_2 + 2N_2O = 2H_2O + 2N_2 + 4H_2$	100	2,804,475	191,160	2720	2705	2612	8.195	
$4H_2 + 2N_2O = 2H_2O + 2N_2 + 2H_2$	96	3,082,940	173,676	2604	2545	3077	9.108	
$2H_2 + 2N_2O = 2H_2O + 2N_2$	92	3,602,050	158,409	2408	2305	3813	10.810	
$2H_2 + 2N_2O + 2N_2 = 2H_2O + 4N_2$	148	3,082,940	173,676	2097	1991	3077	9.108	
$2H_2 + 2N_2O + 3N_2 = 2H_2O + 5N_2$	176	2,920,700	181,520	1993	1880	2826	8.576	
$4NH_3 + 3O_2 = 2N_2 + 6H_2O$	164	7,814,500	432,090	2431	2390	3480	11.876	
$2NH_3 + 3N_2O = 4N_2 + 3H_2O$	166	4,431,400	311,730	2219	2200	3272	9.810	
$2H_2 + 2O_2 = 2H_2O + O_2$	68	2,955,420	82,855	2340	2328	3640	11.63	
$2H_2 + 4O_2 = 2H_2O + 3O_2$	132	2,355,912	107,677	1940	1927	2866	9.068	
$2H_2 + 6O_2 = 2H_2O + 5O_2$	196	2,112,318	132,017	1720	1770	2365	8.027	
$2H_2 + O_2 + N_2 = 2H_2O + N_2$	64	2,955,420	82,855	2412	2426	3640	11.63	
$2H_2 + O_2 + 3N_2 = 2H_2O + 3N_2$	120	2,355,912	107,677	2035	2055	2866	9.068	
$2H_2 + O_2 + 5N_2 = 2H_2O + 5N_2$	176	2,112,318	132,017	1811	1822	2365	8.027	
$4H_2 + O_2 = 2H_2O + 2H_2$	40	2,588,040	97,240	3316	3268	3193	10.06	
$6H_2 + O_2 = 2H_2O + 4H_2$	44	2,201,706	119,262	3517	3527	2605	8.409	
$8H_2 + O_2 = 2H_2O + 6H_2$	48	2,066,688	148,434	3532	3532	2153	7.832	

$C_2H_4 + 2O_2 + N_2 = 2CO + 2H_2O + N_2$	120	4,096,944	221,078	2387	2413	3882	10·233	Heat of combustion = 184,000. Probably a little dissociation [of H_2O].
$C_2H_4 + 2O_2 = 2CO + 2H_2O$	92	4,516,464	321,650	2619	2581	4365	11·273	
$C_2H_4 + 2O_2 + 2N_2 = 2CO + 2H_2O + 2N_2$	148	3,875,408	225,940	2249	2211	3505	9·531	} Below the temperature of complete dissociation of CO_2 . Heat of combustion = 110,800.
$C_2H_4 + 2O_2 + 4N_2 = 2CO + 2H_2O + 4N_2$	204	3,534,088	240,812	2036	2024	2960	8·604	
$C_2H_4 + 2O_2 + 6N_2 = 2CO + 2H_2O + 6N_2$	260	3,323,776	258,401	1882	1878	2577	8·032	
$C_2H_4 + 2O_2 + 8N_2 = 2CO + 2H_2O + 8N_2$	316	3,222,576	265,330	1744	1734	2263	7·757	
$C_2H_4 + 3O_2 = 2CO + 2H_2O + O_2$	124	4,096,944	221,078	2348	2368	3882	10·233	
$C_2H_4 + 4O_2 = 2CO + 2H_2O + 2O_2$	156	3,875,408	225,940	2191	2247	3505	9·531	
$C_2H_4 + 6O_2 = 2CO + 2H_2O + 4O_2$	220	3,534,088	240,812	$\frac{3101}{2}$	—	2960	8·604	
$C_2H_4 + 8O_2 = 2CO + 2H_2O + 6O_2$	284	3,323,776	258,401	$\frac{2766}{2}$	—	2577	8·032	
$C_2H_4 + 10O_2 = 2CO + 2H_2O + 8O_2$	348	3,222,576	265,330	$\frac{2384}{2}$	—	2263	7·757	
$C_2H_2 + O_2 = 2CO + H_2$	58	1,947,199	92,784	3101	2961	5029	7·787	
$2C_2H_2 + 3O_2 = 4CO + O_2 + 2H_2$	148	3,863,374	204,130	2766	2716	4388	7·717	} Dissociation not complete. Cannot be calculated. Heat of combustion = 338,600.
$2C_2H_2 + 3O_2 + 2N_2 = 4CO + 2H_2 + O_2 + 2N_2$..	204	3,820,827	241,641	2384	2414	3517	7·621	
$2C_2H_2 + 3O_2 + 2N_2 = 4CO + 2H_2O + 2N_2$...	204	—	—	—	2414	—	—	
$2C_2H_2 + 3O_2 + 6N_2 = 4CO + 2H_2O + 6N_2$...	316	6,402,474	344,996	2187	2209	3567	8·602	
$2C_2H_2 + 3O_2 + 8N_2 = 4CO + 2H_2O + 8N_2$...	372	6,295,300	372,350	2078	2116	3200	8·296	
$2C_2H_2 + 3O_2 + 10N_2 = 4CO + 2H_2O + 10N_2$	428	6,132,046	397,254	1972	2019	2913	8·055	
$2C_2H_2 + 3O_2 + 12N_2 = 4CO + 2H_2O + 12N_2$	484	5,999,315	426,640	1888	1908	2680	7·859	
$CH_4 + O_2 = CO + H_2O + H_2$	48	1,248,459	111,540	2502	2528	2772	8·663	
$2CH_4 + 3O_2 = 2CO + 4H_2O$	128	6,301,243	333,762	2485	2470	3764	11·797	
$2CH_4 + 3O_2 + N_2 = 2CO + 4H_2O + N_2$	156	5,858,100	328,900	2353	2349	3513	10·897	
$2CH_4 + 3O_2 + 3N_2 = 2CO + 4H_2O + 3N_2$	212	5,255,385	329,600	2160	2154	3114	9·673	
$2CH_4 + 3O_2 + 5N_2 = 2CO + 4H_2O + 5N_2$	268	4,847,186	334,906	2024	1880	2817	8·844	

On referring to the explosion of ethylene with excess of oxygen it is seen that CO_2 is not completely dissociated until a temperature of 3500°C . is reached. In all cases the temperature of explosion of cyanogen with excess of oxygen is above this, and therefore CO_2 is never formed.

The Pressure of Explosion.

The maximum pressure of explosion may be calculated with the aid of the two formulæ

$$\left. \begin{aligned} p - p_0 &= \frac{\mu V^2}{v_0^2} (v_0 - v), \\ \text{and} \quad v &= \frac{C_p}{C_p + C_v} v_0. \end{aligned} \right\}$$

These two equations lead to the formula

$$p = \frac{\mu V^2}{v_0} \frac{C_v}{C_p + C_v} + p_0.$$

The pressure for an explosion of equal volumes of cyanogen and oxygen calculated from this formula is 57 atmospheres. Jones and Bower* by breaking glass tubes obtain the value 58 atmospheres

VII. *The Aqueous Fusion of Glass, its Relation to Pressure and Temperature.* First Paper. By CARL BARUS†.

SOME time ago I published ‡ a series of results due to the action of hot water at 185° on glass, the water being kept liquid by pressure. It was shown that the water contained in sealed capillary glass tubes increased in compressibility while it steadily diminished in bulk, as described in the subjoined summary of two consistent experiments with different tubes. During the observations the column soon became turbid, but it remained translucent enough to admit of measurement. As the action at 185° proceeded, the length of the thread of water decreased. This thread was contained within the walls of the tube between two terminal threads of mercury (the lower being movable and transmitting pressure), and therefore decrease in the length of the thread can only mean contraction of volume of the system of glass and water in contact. The results are as follows:— θ denoting the temperature of the capillary thread (maintained constant by a transparent vapour-bath); t the time

* Journal of the Manchester Lit. and Phil. Soc. 1898.

† Communicated by the Author.

‡ Barus: American Journal of Science, xli. p. 110 (1891).

Capillary tube, with appurtenances,
for measuring the Compressibility
of Liquids.

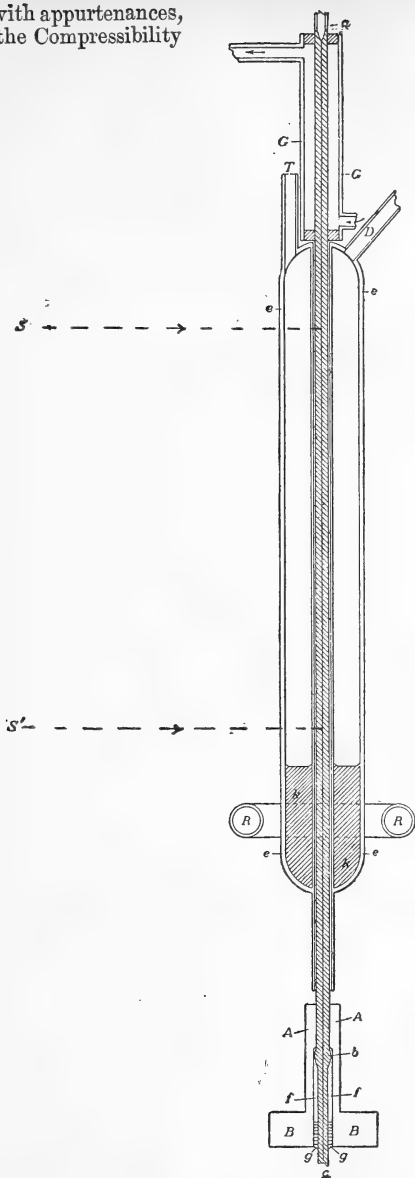

A A B B. Flange screwing to compression-pump.

a b c. Capillary tube containing thread of water between visible threads of mercury. Ends of threads at *S* and *S'*.

G G. Water-bath to cool paraffin plug of capillary tube.

e e e e. Annular vapour-bath of glass, containing charge, *k k*, of aniline oil, kept in ebullition by the ring-burner *R R*. Non-conducting jacketing of tube and screens not shown.

D tubulure for condenser, *T* for thermometer.

Observations made with the cathetometer observing each mercury meniscus along the lines of sight *S*, *S'*, through the clear walls of the glass vapour-bath *e e e e*.

of the observation counting from the beginning of ebullition in the vapour-bath; v the total increment of volume due to the thermal expansion, V the total volume, so that v/V is the mean expansion per unit of volume at 185° ; β the mean compressibility within 300 atmospheres.

TABLE showing Thermal Expansion and Compressibility of Silicated Water at 185° and 20 to 300 atmospheres. Diameter of tube .045 centim. Length of column of water at 24° , 14 centim.

θ .	$v/V \cdot 10^3$.	$\beta \cdot 10^6$.	t .	θ .	$v/V \cdot 10^3$.	$\beta \cdot 10^6$.	t .
$^\circ\text{C}$.			min.	$^\circ\text{C}$.			min.
24	± 0	44		185	+44	141	40
185	+103	77	18	185	+27	163	45
185	86	97	25	185	+05	184	50
185	75	112	30	185	-15	221	55
185	60	125	35	185	-29	...	60

At the conclusion of the experiment the thread was solid, as I supposed, at high pressure (300 atm.), though not apparently so at low pressure. This was inferred since the mercury thread advancing under pressure did not, on removal of pressure, return again as a whole, but broke into small parts in a way to make further measurement without immediate value*. On breaking the tube apart after cooling, and examining it under the microscope, the capillary canal was found to be nearly, if not quite, filled with a white glassy incrustation. This shows that the glass swells in marked degree on hydration, whereas the combined volume of glass and water put into action, simultaneously contracts. If the values of v/V given in the table be examined, it appears that whereas the original volume increment per unit of volume is greater than .103 for the rise of temperature from 24° to 185° at 20 atmospheres, this increment has nearly vanished after 50 minutes of reaction. The thread at 185° is now only as long as it was at 24° . After 60 minutes of reaction it is even markedly shorter at 185° than at 24° , pressure remaining constant throughout.

At the same time the compressibility, β , of the silicated

* A succeeding paper will take up the research from this point onward.

water at 185° is found to increase regularly from $\cdot 000077$ near the beginning of the experiment, to over $\cdot 000221$, or more than three times its initial value on the same isothermal (185°). This result is wholly unexpected, since without exception the effect of solution is a decrease of the compressibility of the solvent, in proportion as more body is dissolved. Silicated water in the present experiment shows the reverse effect. Now although the hydration increases the volume of the glass, the gradual choking of the capillary canal goes on uniformly from top to bottom of the thread of water. Hence, since the bore is diminished at the same rate throughout the wetted tube, the observations for compressibility would remain to the same degree unchanged, *cæt. par.* Supposing that fine particles of the glass were broken off* and gradually accumulated on the mercury meniscus near the bottom of the thread of water, it would be possible to account for the data for β cited, in consideration of the gradual constriction of the thread near the bottom. In such a case, however, the compressing thread of mercury would not have advanced and retreated through this debris with the observed regularity. In general mere stoppage and clogging would have been noticed in duplicate experiments †. I also made correlative experiments with saturated solutions of zinc sulphate in water and naphthalene in alcohol. In both cases markedly increased compressibilities were possible in a turbid column, and due to the precipitation of part of the dissolved salt, isothermally, by pressure. During compression a part of the dissolved body is changed from the liquid to the solid state by pressure, and hence the apparent increase of compressibility.

From this point of view I have endeavoured to account *preliminarily* for the observed regular increase of β given in the table, though I confess some reluctance to this explanation: I have supposed that the dissolved silicate is precipitated out of solution by pressure and redissolved on removing pressure, thus producing accentuated compressibility; that this effect increases as more silicate is taken up in solution, until finally the whole thread becomes too viscous for further observation. However this may be, the fact of a regularly and enormously increased compressibility remains as collateral evidence of the stage of progress of the reaction.

2. There is a final result to be obtained from this experiment, and it is to this that my remarks chiefly apply. The reaction of the water on the glass must be along the surface

* This does not occur. See below.

† Thus for instance the thickness of the thread of mercury seen in the cathetometer did not seem to diminish.

of contact of both bodies. For a given length of thread this surface decreases as the radius, r , of the tube. On the other hand, the volume of water decreases as the square of the radius, r , of the capillary tube. In fact, if V be the volume and S the surface for a given length of thread, $S/V = 2/r$. Let a be the rate of absorption of water in glass, *i. e.*, the number of cub. centim. of water absorbed per square centim. of surface of contact, per minute. If v is the volume absorbed by S cm.² per minute, $v = a S$ and therefore $v/V = 2 a/r$. Hence, if r is large, the apparent effect of absorption vanishes; but in proportion as r is smaller, or as the tube becomes more finely capillary, the effect of absorption will become more obvious to the eye. In other words, the length of the column of water included between the two terminal threads of mercury will decrease faster for small values of the capillary radius. In the above results v/V taken directly from the table is about .003 cub. centim. per minute. The diameter of the tube measured microscopically was found to be about .045 centim. Therefore $a = .000034$ cub. centim. is the volume of water absorbed per square centim. of surface of contact, per minute, at 185°. This is about 180 kg., per sq. metre, per year, at 185°.

True the phenomenon is not quite so simple as here computed, for as the action proceeds the water holds more body in solution, the area of unchanged glass increases, and possibly the liquid must diffuse or percolate through the layer of opalescent accretion to reach it. As against the seriousness of this consideration, one may allude to the regularity of the above results in the lapse of time and the occurrence of a reaction rather accelerated as time increases.

In view of the large surfaces of reaction available even in small bulks of porous or triturated rock and the fact that the intensity of the reaction increases rapidly with temperature, I cannot but regard this result as important. Direct experiments* have been made with care to detect a possible thermal effect (rise of temperature) of the action of water on hot glass, but thus far without positive results. The difficulties of such experiments are very great. To insure chemical reaction, they must be made with superheated water under pressure, with allowances for heat conduction &c., all of which make the measurement of small increments of temperature very uncertain. If, however, rise of temperature may be associated with the marked contraction of volume in the system water-glass specified, one may note, in the first place, that for a

* G. F. Becker: Monographs U. S. Geolog. Survey, No. III., 1882. I have since made similar experiments with superheated water (200°).

capillary canal about one half millimetre in diameter, the absorption of water is as great as 18 per cent. of the volume contained per hour. In finely porous rock correspondingly larger absorptions are to be anticipated. Again, the temperatures and pressures given in the above experiments would be more than reached by a column of water penetrating a few miles below the earth's surface. Finally, the action of water on silicates will be accelerated in proportion as higher temperatures are entered with increasing terrestrial depth. Eventually, therefore, heat must be evolved more rapidly than it is conducted away.

With the above proviso, one may reasonably conclude that the action of hot water on rock within the earth constitutes a furnace whose efficiency increases in marked degree with the depth of the seat of reaction below sea-level.

Brown University,
Providence, U.S.A.

VIII. *Uranium Radiation and the Electrical Conduction produced by it.* By E. RUTHERFORD, M.A., B.Sc., formerly 1851 Science Scholar, Couatts Trotter Student, Trinity College, Cambridge; McDonald Professor of Physics, McGill University, Montreal*.

THE remarkable radiation emitted by uranium and its compounds has been studied by its discoverer, Becquerel, and the results of his investigations on the nature and properties of the radiation have been given in a series of papers in the *Comptes Rendus*†. He showed that the radiation, continuously emitted from uranium compounds, has the power of passing through considerable thicknesses of metals and other opaque substances; it has the power of acting on a photographic plate and of discharging positive and negative electrification to an equal degree. The gas through which the radiation passes is made a temporary conductor of electricity and preserves its power of discharging electrification for a short time after the source of radiation has been removed.

The results of Becquerel showed that Röntgen and uranium radiations were very similar in their power of penetrating solid bodies and producing conduction in a gas exposed to them; but there was an essential difference between the two types of radiation. He found that uranium radiation could be refracted and polarized, while no definite results showing

* Communicated by Prof. J. J. Thomson, F.R.S.

† *C. R.* 1896, pp. 420, 501, 559, 689, 762, 1086; 1897, pp. 438, 800.

polarization or refraction have been obtained for Röntgen radiation.

It is the object of the present paper to investigate in more detail the nature of uranium radiation and the electrical conduction produced. As most of the results obtained have been interpreted on the ionization-theory of gases which was introduced to explain the electrical conduction produced by Röntgen radiation, a brief account is given of the theory and the results to which it leads.

In the course of the investigation, the following subjects have been considered:—

- § 1. Comparison of methods of investigation.
- § 2. Refraction and polarization of uranium radiation.
- § 3. Theory of ionization of gases.
- § 4. Complexity of uranium radiation.
- § 5. Comparison of the radiation from uranium and its compounds.
- § 6. Opacity of substances for the radiation.
- § 7. Thorium radiation.
- § 8. Absorption of radiation by gases.
- § 9. Variation of absorption with pressure.
- § 10. Effect of pressure of the gas on the rate of discharge.
- § 11. The conductivity produced in gases by complete absorption of the radiation.
- § 12. Variation of the rate of discharge with distance between the plates.
- § 13. Rate of re-combination of the ions.
- § 14. Velocity of the ions.
- § 15. Fall of potential between two plates.
- § 16. Relation between the current through the gas and electromotive force applied.
- § 17. Production of charged gases by separation of the ions.
- § 18. Discharging power of fine gauzes.
- § 19. General remarks.

§ 1. *Comparison of Methods of Investigation.*

The properties of uranium radiation may be investigated by two methods, one depending on the action on a photographic plate and the other on the discharge of electrification. The photographic method is very slow and tedious, and admits of only the roughest measurements. Two or three days' exposure to the radiation is generally required to produce any marked effect on the photographic plate. In addition, when we are dealing with very slight photographic action, the

fogging of the plate, during the long exposures required, by the vapours of substances* is liable to obscure the results. On the other hand the method of testing the electrical discharge caused by the radiation is much more rapid than the photographic method, and also admits of fairly accurate quantitative determinations.

The question of polarization and refraction of the radiation can, however, only be tested by the photographic method. The electrical experiment (explained in § 2) to test refraction is not very satisfactory.

§ 2. *Polarization and Refraction.*

The almost identical effects produced in gases by uranium and Röntgen radiation (which will be described later) led me to consider the question whether the two types of radiation did not behave the same in other respects.

In order to test this, experiments were tried to see if uranium radiation could be polarized or refracted. Becquerel † had found evidence of polarization and refraction, but in repeating experiments similar to those tried by him, I have been unable to find any evidence of either. A large number of photographs by the radiation have been taken under various conditions, but in no case have I been able to observe any effect on the photographic plate which showed the presence of polarization or refraction.

In order to avoid fogging of the plate during the long exposures required, by the vapours of substances, lead was employed as far as possible in the neighbourhood of the plate, as its effect on the film is very slight.

A brief account will now be given of the experiments on refraction and polarization.

Refraction.—A thick lead plate was taken and a long narrow slit cut through it; this was placed over a uniform layer of uranium oxide; the arrangement was then equivalent to a line source of radiation and a slit. Thin prisms of glass, aluminium, and paraffin-wax were fixed at intervals on the lead plate with their edges just covering the slit. A photographic plate was supported 5 mms. from the slit. The plate was left for a week in a dark box. On developing a dark line was observed on the plate. This line was not appreciably broadened or displaced above the prisms. Different sizes of slits gave equally negative results. If there was any appreciable refraction we should expect the image of the slit to be displaced from the line of the slit.

* Russell, Proc. Roy. Soc. 1897.

† C. R. 1896, p. 559.

Becquerel* examined the opacity of glass for uranium radiation in the solid and also in a finely-powdered state by the method of electric leakage, and found that, if anything, the transparency of the glass for the radiation was greater in the finely-divided than in the solid state. I have repeated this experiment and obtained the same result. As Becquerel stated, it is difficult to reconcile this result with the presence of refraction.

Polarization.—An arrangement very similar to that used by Becquerel was employed. A deep hole was cut in a thick lead plate and partly filled with uranium oxide. A small tourmaline covered the opening. Another small tourmaline was cut in two and placed on top of the first, so that in one half of the opening the tourmalines were crossed and in the other half uncrossed. The tourmalines were very good optically. The photographic plate was supported 1 to 3 mm. above the tourmalines. The plate was exposed four days, and on developing a black circle showed up on the plate, but in not one of the photographs could the slightest difference in the intensity be observed. Becquerel † stated that in his experiment the two halves were unequally darkened, and concluded from this result that the radiation was doubly refracted by tourmaline, and that the two rays were unequally absorbed.

§ 3. Theory of Ionization.

To explain the conductivity of a gas exposed to Röntgen radiation, the theory ‡ has been put forward that the rays in passing through the gas produce positively and negatively charged particles in the gas, and that the number produced per second depends on the intensity of the radiation and the pressure.

These carriers are assumed to be so small that they will move with a uniform velocity through a gas under a constant potential gradient. The term ion was given to them from analogy with electrolytic conduction, but in using the term it is not assumed that the ion is necessarily of atomic dimensions; it may be a multiple or submultiple of the atom.

Suppose we have a gas between two plates exposed to the radiation and that the plates are kept at a constant difference of potential. A certain number of ions will be produced per second by the radiation and the number produced will in general depend on the pressure of the gas. Under the electric

* *C. R.* 1896, p. 559.

† *C. R.* 1896, p. 559.

‡ J. J. Thomson and E. Rutherford, *Phil. Mag.* Nov. 1896.

field the positive ions travel towards the negative plate and the negative ions towards the other plate, and consequently a current will pass through the gas. Some of the ions will also recombine, the rate of recombination being proportional to the square of the number present. The current passing through the gas for a given intensity of radiation will depend on the difference of potential between the plates, but when the potential-difference is greater than a certain value the current will reach a maximum. When this is the case all the ions are removed by the electric field before they can recombine.

The positive and negative ions will be partially separated by the electric field, and an excess of ions of one sign may be blown away, so that a charged gas will be obtained. If the ions are not uniformly distributed between the plates, the potential gradient will be disturbed by the movement of the ions.

If energy is absorbed in producing ions, we should expect the absorption to be proportional to the number of ions produced and thus depend on the pressure. If this theory be applied to uranium radiation we should expect to obtain the following results:—

- (1) Charged carriers produced through the volume of the gas.
- (2) Ionization proportional to the intensity of the radiation and the pressure.
- (3) Absorption of radiation proportional to pressure.
- (4) Existence of saturation current.
- (5) Rate of recombination of the ions proportional to the square of the number present.
- (6) Partial separation of positive and negative ions.
- (7) Disturbance of potential gradient under certain conditions between two plates exposed to the radiation.

The experiments now to be described sufficiently indicate that the theory does form a satisfactory explanation of the electrical conductivity produced by uranium radiation.

In all experiments to follow, the results are independent of the sign of the charged plate, unless the contrary is expressly stated.

§ 4. *Complex Nature of Uranium Radiation.*

Before entering on the general phenomena of the conduction produced by uranium radiation, an account will be given of some experiments to decide whether the same radiation is emitted by uranium and its compounds and whether the radiation is

homogeneous. Röntgen and others have observed that the x -rays are in general of a complex nature, including rays of wide differences in their power of penetrating solid bodies. The penetrating power is also dependent to a large extent on the stage of exhaustion of the Crookes tube.

In order to test the complexity of the radiation, an electrical method was employed. The general arrangement is shown in fig. 1.

Fig. 1.

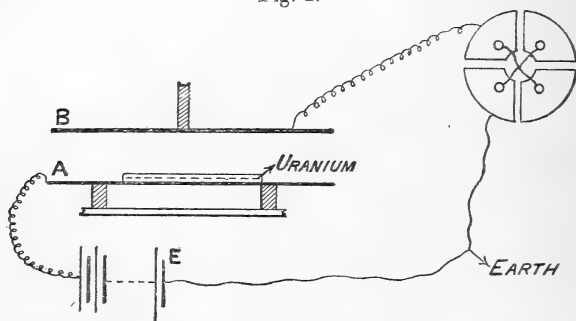

The metallic uranium or compound of uranium to be employed was powdered and spread uniformly over the centre of a horizontal zinc plate A, 20 cm. square. A zinc plate B, 20 cm. square, was fixed parallel to A and 4 cm. from it. Both plates were insulated. A was connected to one pole of a battery of 50 volts, the other pole of which was to earth; B was connected to one pair of quadrants of an electrometer, the other pair of which was connected to earth.

Under the influence of the uranium radiation there was a rate of leak between the two plates A and B. The rate of movement of the electrometer-needle, when the motion was steady, was taken as a measure of the current through the gas.

Successive layers of thin metal foil were then placed over the uranium compound and the rate of leak determined for each additional sheet. The table (p. 115) shows the results obtained for thin Dutch metal.

In the third column the ratio of the rates of leak for each additional thickness of metal leaf is given. Where two thicknesses were added at once, the square root of the observed ratio is taken, for three thicknesses the cube root. The table shows that for the first ten thicknesses of metal the rate of leak diminished approximately in a geometrical progression as the thickness of the metal increased in arithmetical progression.

Thickness of Metal Leaf .00008 cm.

Layer of Uranium Oxide on plate.

Number of Layers.	Leak per min. in scale-divisions.	Ratio for each layer.
0	91	
1	77	.85
2	60	.78
3	49	.82
4	42	.86
5	33	.79
6	24.7	.75
8	15.4	.79
10	9.1	.77
13	5.8	.86

It will be shown later (§ 8) that the rate of leak between two plates for a saturating voltage is proportional to the intensity of the radiation after passing through the metal. The voltage of 50 employed was not sufficient to saturate the gas, but it was found that the comparative rates of leak under similar conditions for 50 and 200 volts between the plates were nearly the same. When we are dealing with very small rates of leak, it is advisable to employ as small a voltage as possible, in order that any small changes in the voltage of the battery should not appreciably affect the result. For this reason the voltage of 50 was used, and the comparative rates of leak obtained are very approximately the same as for saturating electromotive forces.

Since the rate of leak diminishes in a geometrical progression with the thickness of metal, we see from the above statement that the intensity of the radiation falls off in a geometrical progression, *i. e.* according to an ordinary absorption law. This shows that the part of the radiation considered is approximately homogeneous.

With increase of the number of layers the absorption commences to diminish. This is shown more clearly by using uranium oxide with layers of thin aluminium leaf (see table p. 116).

It will be observed that for the first three layers of aluminium foil, the intensity of the radiation falls off according to the ordinary absorption law, and that, after the fourth thickness, the intensity of the radiation is only slightly diminished by adding another eight layers.

Thickness of Aluminium foil $\cdot 0005$ cm.

Number of Layers of Aluminium foil.	Leak per min. in scale-divisions.	Ratio.
0	182	
1	77	$\cdot 42$
2	33	$\cdot 43$
3	14.6	$\cdot 44$
4	9.4	$\cdot 65$
12	7	

The aluminium foil in this case was about $\cdot 0005$ cm. thick, so that after the passage of the radiation through $\cdot 002$ cm. of aluminium the intensity of the radiation is reduced to about $\frac{1}{20}$ of its value. The addition of a thickness of $\cdot 001$ cm. of aluminium has only a small effect in cutting down the rate of leak. The intensity is, however, again reduced to about half of its value after passing through an additional thickness of $\cdot 05$ cm., which corresponds to 100 sheets of aluminium foil.

These experiments show that the uranium radiation is complex, and that there are present at least two distinct types of radiation—one that is very readily absorbed, which will be termed for convenience the α radiation, and the other of a more penetrative character, which will be termed the β radiation.

The character of the β radiation seems to be independent of the nature of the filter through which it has passed. It was found that radiation of the same intensity and of the same penetrative power was obtained by cutting off the α radiation by thin sheets of aluminium, tinfoil, or paper. The β radiation passes through all the substances tried with far greater facility than the α radiation. For example, a plate of thin cover-glass placed over the uranium reduced the rate of leak to $\frac{1}{30}$ of its value; the β radiation, however, passed through it with hardly any loss of intensity.

Some experiments with different thicknesses of aluminium seem to show, as far as the results go, that the β radiation is of an approximately homogeneous character. The following table gives some of the results obtained for the β radiation from uranium oxide:—

β Radiation.

Thickness of Aluminium.	Rate of Leak.
·005	1
·028	·68
·051	·48
·09	·25

The rate of leak is taken as unity after the α radiation has been absorbed by passing through ten layers of aluminium foil. The intensity of the radiation diminishes with the thickness of metal traversed according to the ordinary absorption law. It must be remembered that when we are dealing with the β radiation alone, the rate of leak is in general only a few per cent. of the leak due to the α radiation, so that the investigation of the homogeneity of the β radiation cannot be carried out with the same accuracy as for the α radiation. As far, however, as the experiments have gone, the results seem to point to the conclusion that the β radiation is approximately homogeneous, although it is possible that other types of radiation of either small intensity or very great penetrating power may be present.

§ 5. Radiation emitted by different Compounds of Uranium.

All the compounds of uranium examined gave out the two types of radiation, and the penetrating power of the radiation for both the α and β radiations is the same for all the compounds.

The table (p. 118) shows the results obtained for some of the uranium compounds.

Fig. 2 shows graphically some of the results obtained for the various uranium compounds. The ordinates represent rates of leak, and the abscissas thicknesses of aluminium through which the radiation has passed.

The different compounds of uranium gave different rates of leak, but, for convenience of comparison, the rate of leak due to the uncovered salt is taken as unity.

It will be seen that the rate of decrease is approximately the same for the first layer of metal, and that the rate of decrease becomes much slower after four thicknesses of foil.

The rate of leak due to the β radiation is a different proportion of the total amount in each case. The uranium

Thickness of Aluminium foil $\cdot 0005$ cm.

Number of Layers of Aluminium foil.	Proportionate Rate of Leak.			
	Uranium metal.	Uranium Nitrate.	Uranium Oxide.	Uranium Potassium Sulphate.
0	1	1	1	1
1	$\cdot 51$	$\cdot 43$	$\cdot 42$	$\cdot 42$
2	$\cdot 35$	$\cdot 28$	$\cdot 18$	$\cdot 27$
3	...	$\cdot 17$	$\cdot 08$	$\cdot 17$
4	...	$\cdot 15$	$\cdot 05$	$\cdot 12$
5	$\cdot 15$
12	...	$\cdot 125$	$\cdot 04$	$\cdot 11$

Fig. 2.

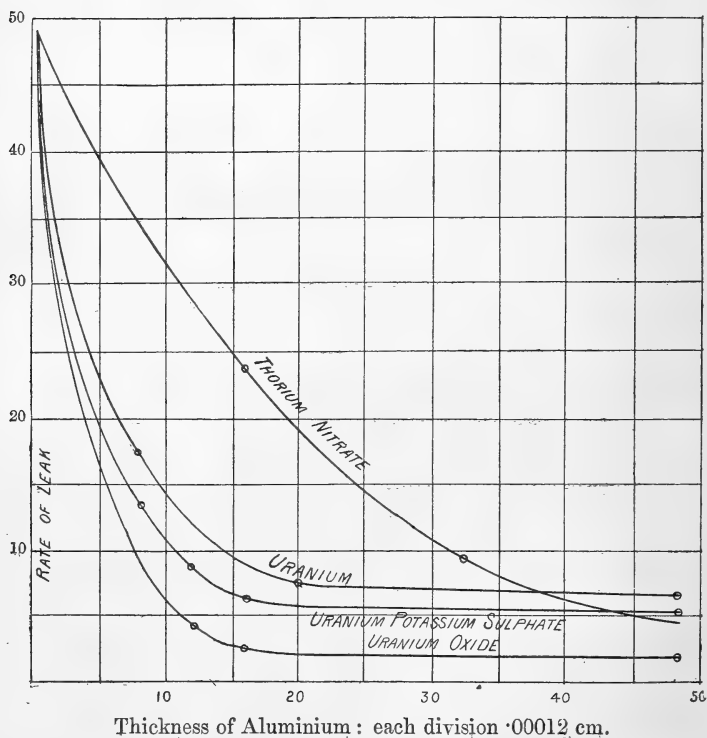

metal was used in the form of powder, and a smaller area of it was used than in the other cases. For the experiments on uranium oxide a thin layer of fine powder was employed, and we see, in that case, that the β radiation bears a much smaller proportion to the total than for the other compounds. When a thick layer of the oxide was used there was, however, an increase in the ratio, as the following table shows:—

Number of layers of Aluminium foil.	Rate of Leak.	
	Thin layer of Uranium Oxide.	Thick layer of Uranium Oxide.
0	1	1
1	·42	5
2	·18	...
4	·05	·12
8	...	·113
12	·04	...
18	...	·11

The amount of the α radiation depends chiefly on the surface of the uranium compound, while the β radiation depends also on the thickness of the layer. The increase of the rate of leak due to the β radiation with the thickness of the layer indicates that the β radiation can pass through a considerable thickness of the uranium compound. Experiments showed that the leak due to the α radiation did not increase much with the thickness of the layer. I did not, however, have enough uranium salt to test the variation of the rate of leak due to the β radiation for thick layers.

The rate of leak from a given weight of uranium or uranium compound depends largely on the amount of surface. The greater the surface, the greater the rate of leak. A small crystal of uranium nitrate was dissolved in water, and the water then evaporated so as to deposit a thin layer of the salt over the bottom of the dish. This gave quite a large leakage. The leakage in such a case is due chiefly to the α radiation.

Since the rate of leak due to any uranium compound depends largely on its amount of surface, it is difficult to compare the quantity of radiation given out by equal amounts of different salts: for the result will depend greatly on the

state of division of the compound. It is possible that the apparently very powerful radiation obtained from pitchblende by Curie* may be partly due to the very fine state of division of the substance rather than to the presence of a new and powerful radiating substance.

The rate of leak due to the β radiation is, as a rule, small compared with that produced by the α radiation. It is difficult, however, to compare the relative intensities of the two kinds. The α radiation is strongly absorbed by gases (§ 8), while the β radiation is only slightly so. It will be shown later (§ 8) that the absorption of the radiation by the gas is approximately proportional to the number of ions produced. If therefore the β radiation is only slightly absorbed by the gas, the number of ions produced by it is small, *i. e.* the rate of leak is small. The comparative rates of leak due to the α and β radiation is thus dependent on the relative absorption of the radiations by the gas as well as on the relative intensity.

The photographic actions of the α and β radiations have also been compared. A thin uniform layer of uranium oxide was sprinkled over a glass plate; one half of the plate was covered by a piece of aluminium of sufficient thickness to practically absorb the α radiation. The photographic plate was fixed about 4 mm. from the uranium surface. The plate was exposed 48 hours, and, on developing, it was found that the darkening of the two halves was not greatly different. On the one half of the plate the action was due to the β radiation alone, and on the other due to the α and β radiations together. Except when the photographic plate is close to the uranium surface, the photographic action is due principally to the β radiation.

§ 6. *Transparency of Substances to the two Types of Radiation.*

If the intensity of the radiation in traversing a substance diminishes according to the ordinary absorption law, the ratio r of the intensity of the radiation after passing through a distance d of the substance to the intensity when the substance is removed is given by

$$r = e^{-\lambda d},$$

where λ is the coefficient of absorption and $e = 2.7$.

In the following table a few values of λ are given for the α and β radiations, assuming in each case that the radiation is

* *C. R.* July 1898, p. 175.

simple and that the intensity falls off according to the above law:—

Substance.	λ for the α radiation.	λ for the β radiation.
Dutch metal	2700
Aluminium	1600	15
Tinfoil	2650	108
Copper	49
Silver	97
Platinum	240
Glass	5.6

The above results show what a great difference there is in the power of penetration of the two types of radiation. The transparency of aluminium for the β radiation is over 100 times as great as for the α radiation. The opacity of the metals aluminium, copper, silver, platinum for the β radiation follows the same order as their atomic weights. Aluminium is the most transparent of the metals used, but glass is more transparent than aluminium for the β radiation. Platinum has an opacity 16 times as great as aluminium. For the α radiation, aluminium is more transparent than Dutch metal or tinfoil.

For a thickness of aluminium .09 cm. the intensity of the β radiation was reduced to .25 of its value; for a thickness of copper .03 cm. the intensity was reduced to .23 of its value. These results are not in agreement with some given by Becquerel *, who found copper was more transparent than aluminium for uranium radiation.

The β radiation has a penetrating power of about the same order as the radiation given out by an average x -ray bulb. Its power of penetration is, however, much less than for the rays from a "hard" bulb. The α radiation, on the other hand, is far more easily absorbed than rays from an ordinary bulb, but is very similar in its penetrating power to the secondary radiation † sent out when x -rays fall upon a metal surface.

It is possible that the α radiation is a secondary radiation set up at the surface of the uranium by the passage of the β radiation through the uranium, in exactly the same way

* *C. R.* 1896, p. 763.

† Perrin, *C. R.* cxxiv. p. 455; Sagnac, *C. R.* 1898.

as a diffuse radiation is produced at the surface of a metal by the passage of Röntgen-rays through it. There is not, however, sufficient evidence at present to decide the question.

§ 7. *Thorium Radiation.*

While the experiments on the complex nature of uranium radiation were in progress, the discovery* that thorium and its salts also emitted a radiation, which had general properties similar to uranium radiation, was announced. A few experiments were made to compare the types of radiation emitted by uranium and thorium.

The nitrate and the sulphate of thorium were used and gave similar results, although the nitrate appeared to be the more active of the two. The leakage effects due to these salts were of quite the same order as those obtained for the uranium compounds; but no satisfactory quantitative comparison can be made between the uranium and thorium salts as the amount of leak depends on the amount of surface and thickness of the layer.

It was found that thorium nitrate when first exposed to the air on a platinum plate was not a steady source of radiation, and for a time the rate of leak varied very capriciously, being sometimes five times as great as at others. The salt was very deliquescent, but after exposure of some hours to the atmosphere the rate of leak became more constant and allowed of rough comparative measurements. Thorium sulphate was more constant than the nitrate.

The absorption of the thorium radiation was tested in the same way as for uranium radiation. The following table gives some of the results. The aluminium foil was of the same thickness (·0005 cm.) as that used in the uranium experiments:—

Number of Layers of Aluminium foil.	Leak per minute in scale-divisions.
0	200
4	94
8	37
12	19
17	7·5

* G. C. Schmidt, *Wied. Annal.* May 1898.

The curve showing the relation between the rate of leak and the thickness of the metal traversed is shown in fig. 2 (p. 118), together with the results for uranium.

It will be seen that thorium radiation is different in penetrative power from the α radiation of uranium. The radiation will pass through between three and four thicknesses of aluminium foil before the intensity is reduced to one-half, while with uranium radiation the intensity is reduced to less than a half after passing through one thickness of foil.

With a thick layer of thorium nitrate it was found that the radiation was not homogeneous, but rays of a more penetrative kind were present. On account of the inconstancy of thorium nitrate as a source of radiation, no accurate experiments have been made on this point.

The radiations from thorium and uranium are thus both complex, and as regards the α type of radiation are different in penetrating power from each other.

In all the experiments on uranium and thorium, care was taken that no stray radiation was present which would obscure the results. Such precautions are very necessary when the rate of leak, due to the radiation transmitted through a considerable thickness of metal, is only a small percentage of the total. The method generally employed was to cover the layer of active salt with the metal screen, and then place in position over it a large sheet of lead with a rectangular hole cut in it of smaller area than that of the layer of salt. The lead was pressed tightly down, and the only radiation between the parallel plates had to pass through the metal screen, as the lead was too thick to allow any to go through.

§8. *Absorption of Uranium Radiation by Gases.*

The α radiation from uranium and its compounds is rapidly absorbed in its passage through gases. The absorption for hydrogen, air, and carbonic acid was determined, and was found to be least in hydrogen and greatest in carbonic acid. To show the presence of absorption, the following arrangement (fig. 3) was used:—

A layer of uranium-potassium sulphate or uranium oxide was spread uniformly over a metal plate P, forming a lamella of 11 cm. diameter. A glass vessel G, 12 cm. in diameter, was placed over the layer. Two parallel metal plates A and B, 1.5 cm. apart, were insulated from each other by ebonite rods. A circular opening 7 cm. in diameter was cut in the plate A, and the opening covered by a sheet of aluminium foil 0.0005 cm. thick. The plate B was connected through a

rod R to a screw adjustment, S, so that the condenser AB could be moved as a whole parallel to the base-plate. The system AB was adjusted parallel to the uranium surface and did not rotate with the screw. The rod R passed through

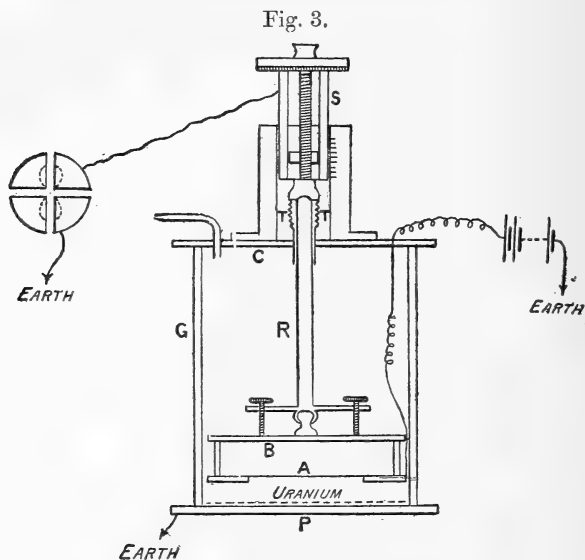

a short glass tube fixed in the ebonite plate C. A short piece of indiarubber tubing T was passed over the glass tube and a projecting flange in which the rod R was screwed. This served the same purpose as the usual stuffing-box, and allowed the distance of AB from the uranium to be adjusted under low pressures.

The plate A was connected to one pole of a battery of 60 volts, the other pole of which was to earth. The plate B was connected through the screw to one pair of quadrants of an electrometer, the other pair of which was to earth. In order to avoid the collection of an electrostatic charge on the glass surface due to the conduction between the uranium and the glass near it, it was found very necessary to coat the inside of the glass cylinder with tinfoil. The tinfoil and base-plate P were connected to earth.

Since the surface of the uranium layer may be supposed to be giving out radiation uniformly from all parts, the intensity of the radiation at points near the centre of the uranium surface should be approximately uniform. If there were no absorption of the radiation in the gas, we should expect the intensity of the radiation to vary but slightly with

distances from the surface small compared with the diameter of the radiating surface.

The radiation passing through the aluminium produces conductivity between A and B (fig. 3), and the rate of leak depends on the intensity of the radiation which has passed through a certain thickness of gas and the aluminium foil. As the system AB is moved from the base-plate, if there is a rapid absorption of the radiation in the gas, we should expect the rate of leak to fall off rapidly, and this is found to be the case. The following table gives the results obtained for air, hydrogen, carbonic acid, and coal-gas. For the first reading the distance d of the aluminium foil from the base-plate was about 3.5 mm.

Distance of Al. foil from Uranium.	Rate of leak between plates.			
	Hydrogen.	Air.	Carbonic Acid.	Coal-gas.
d	1	1	1	1
$d + 1.25$ mm.74	...
„ + 2.5 „67	.57	.81
„ + 3.75 „41	...
„ + 5 „	.84	.45	.32	.63
„ + 7.5 „31
„ + 10 „	.67	.2139
„ + 12.5 „16
„ + 15 „	.5322

The rate of leak for the distance d is taken as unity in each gas for the purpose of comparison. The actual rates of leak between A and B for the distance d is given in the following table :—

Gas.	Rate of leak in scale-divisions per min.
Hydrogen	25
Coal-gas	35
Air	28
Carbonic acid	18

The results of the previous table are shown graphically in fig. 4, where the ordinates represent currents and the abscissæ

Fig. 4.

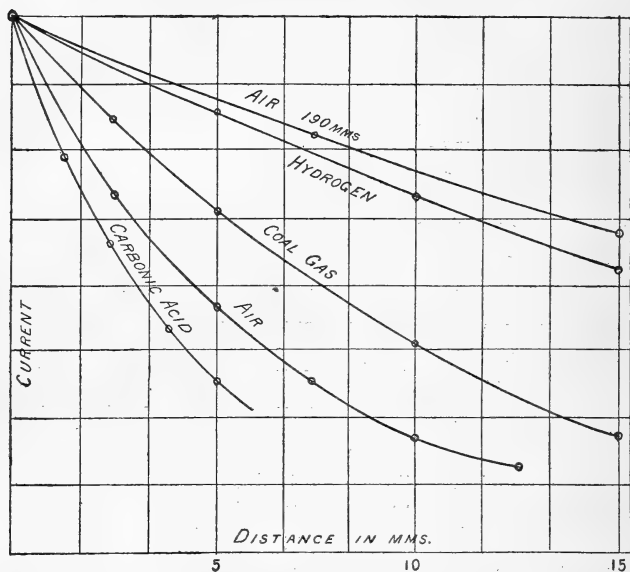

distances from the base-plate. It will be seen that the current decreases most rapidly in carbonic acid and least in hydrogen. As the distance from the base-plate increases in arithmetical progression, the rate of leak diminishes approximately in geometrical progression. The rapid decrease of the current is due to the absorption of the radiation in its passage through the gas. The decrease of the current in air at 190 mm. pressure is also shown in the figure. Since the absorption is smaller for air at this pressure than at normal pressure, the rate of leak diminishes much more slowly with the distance.

In the above experiments both the α and β radiations produce conductivity in the gas. A thin layer of uranium oxide was, however, used, and in that case the rate of leak due to the β radiation may be neglected in comparison with that produced by the α radiation.

The results that have been obtained on the variation of the rate of leak with distance may be simply interpreted on the theory of the ionization of the gas through which the radiation passes. It is assumed that the rate of ionization is

proportional to the intensity of the radiation (as is the case in Röntgen-ray conduction), and that the intensity of the radiation near the uranium surface is constant over a plane parallel to that surface. This is very approximately the case if the distance from the uranium surface is small compared with the diameter of the radiating surface.

For simplicity we will consider the case of an infinite plane of uranium giving out homogeneous radiation.

If I be the intensity of the radiation close to the uranium surface, the intensity at a distance x is equal to $Ie^{-\lambda x}$ where λ is the coefficient of absorption of the gas. The intensity is diminished in passing through the layer of aluminium foil A (fig. 3) in a constant ratio for all distances from the uranium. The intensity at a distance x after passing through the aluminium is thus $\kappa Ie^{-\lambda x}$ where κ is a constant. The rate of production of the ions between two parallel planes between A and B (fig. 3) at distances $x + dx$ and x from the uranium is therefore proportional to $\kappa Ie^{-\lambda x} dx$. If r be the distance of A from the uranium, and l the distance between A and B, the total number of ions produced per second between A and B is proportional to

$$\int_r^{l+r} \kappa I e^{-\lambda x} dx,$$

or to

$$\frac{\kappa I}{\lambda} e^{-\lambda r} \{1 - e^{-\lambda l}\}.$$

When a "saturating" electromotive force (see § 16) acts between A and B, the current is proportional to the total number of ions produced. Now, as the system AB is moved from the radiating surface, $\frac{\kappa I}{\lambda} (1 - e^{-\lambda l})$ is a constant for any particular gas. We thus see that the rate of leak is proportional to $e^{-\lambda r}$, or the rate of leak decreases in geometrical progression as the distance r increases in arithmetical progression.

This result allows us to at once deduce the value of the coefficient of absorption for different gases from the data we have previously given.

The results are given in the following table :—

Gas.	Value of λ .
Hydrogen	·43
Air	1·6
Carbonic acid	2·3
Coal-gas.....	·93

or, to express the same results in a different way, the intensity of the radiation from an infinite plane of uranium is reduced by absorption to half its value after having passed through

3 mm. of carbonic acid,
4·3 mm. of air,
7·5 mm. of coal-gas,
16·3 mm. of hydrogen.

We see that the absorption is least in hydrogen and greatest in carbonic acid, and follows the same order as the density of the gases.

The values given above are for the α radiation. The β radiation is not nearly so rapidly absorbed as the α , but, on account of the small electrical leakage produced in its passage through the gas, it was not found feasible to measure the absorption in air or other gases.

The absorption of the α radiation by gases is very much greater than the absorption of rays from an ordinary Crookes' tube. In a previous paper * it has been shown that the value of λ for the radiation from the particular bulb used was ·01. The absorption coefficient for the α radiation is 1·6, or 160 times as great. The absorption of the β radiation in gases is probably of the same order as the absorption for ordinary x -rays.

§ 9. Variation of Absorption with Pressure.

The absorption of the α radiation increases with increase of pressure and very approximately varies directly as the pressure.

The same apparatus was used as in fig. 3, and the vessel was kept connected to an air-pump. The variation of the

* Phil. Mag. April 1897.

rate of leak between A and B for different distances from the base-plate was determined for pressures of 760, 370, and 190 mm., and the results are given below :—

Distance of A from Uranium.	Rate of leak between plates.		
	Air 760 mm.	Air 370 mm.	Air 190 mm.
d (= 3·5 mm.)	1	1	1
„ + 2·5 mm.	67
„ + 5 „	·45	·71	...
„ + 7·5 „	·31	...	·78
„ + 10 „	·21	·51	...
„ + 12·5 „	·16
„ + 15 „	...	·36	·59

For the purpose of comparison the rate of leak at the distance d is taken as unity in each case. It can readily be deduced from the results that the intensity of the radiation is reduced to half its value after passing through

4·3 mm. of air at 760 mm.
 10 „ „ 370 „
 19·5 „ „ 190 „

The absorption is thus approximately proportional to the pressure for the range that has been tried. It was not found feasible to measure the absorption at lower pressures on account of the large distances through which the radiation must pass to be appreciably absorbed.

A second method of measuring the absorption of the radiation in gases, which depends on the variation of the rate of leak between two plates as the distance between them is varied, is given in § 12.

§ 10. *Effect of Pressure on the Rate of Discharge.*

Becquerel* has given a few results for the effects of pressure, and showed that the rate of leak due to uranium diminished with the pressure. Beattie and S. de Smolan † also

* *Comptes Rendus*, p. 438 (1897).

† *Phil. Mag.* xliii. p. 418 (1897).

investigated the subject, and came to the conclusion that in some cases the rate of leak varied as the pressure, and in others as the square root of the pressure, according to the voltage employed. Their tabulated results, however, do not show any close agreement with either law, and in fact, as I hope to show later, the relation between the rate of leak and the pressure is a very variable one, depending to a large extent on the distances between the uranium and the sur-

Fig. 5.

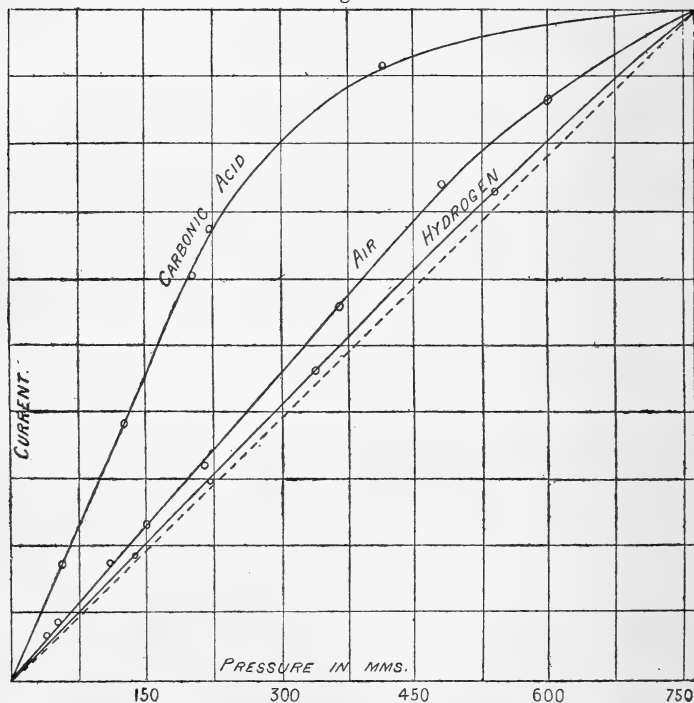

rounding conductors, as well as on the gas employed. The subject is greatly complicated by the rapid absorption of the radiation by gases, but all the results obtained may be interpreted on the assumption that the rate of production of ions at any point varies directly as the *intensity* of the radiation and the *pressure* of the gas.

To determine the effects of pressure, an apparatus similar to fig. 3 was used, with the difference that the plate A was removed. The uranium compound was spread uniformly over the central part of the lower plate. The movable plate, which was connected with the electrometer, was 10 cm.

in diameter and moved parallel to the uranium surface. The base-plate was connected to one pole of a battery of 100 volts, the other pole of which was connected to earth. The rate of movement of the electrometer-needle was taken as a measure of the current between the plates. In some cases the uranium compound was covered with a thin layer of aluminium foil, but although this diminished the rate of leak the general relations obtained were unaltered.

The following tables give the results obtained for air, hydrogen, and carbonic acid at different pressures with a potential-difference of 100 volts between the plates—an amount sufficient to approximately “saturate” the gases air and hydrogen. Much larger voltages are required to produce approximate saturation for carbonic acid.

Air : Uranium oxide on base-plate. Plates about 3·5 mm. apart.

Air.

Pressure.	Current.
mm. 760	1
600	·86
480	·74
365	·56
210	·32
150	·23
100	·17
50	·088
35	·062

For hydrogen and carbonic acid. Plates about 3·5 mm. apart.

Hydrogen.

Pressure.	Current.
mm. 760	1
540	·73
335	·46
220	·29
135	·18

Carbonic Acid.

Pressure.	Current.
mm. 760	1
410	·92
220	·69
125	·38
55	·175

The current at atmospheric pressure is in each case taken as unity for comparison, although the actual rates of leak were different for the three gases. Fig. 5 (p. 130) shows these results graphically, where the ordinates represent current and the abscissæ pressure. The dotted line shows the position of the curve if the rate of leak varied directly as the pressure. It will be observed that for all three gases the rate of leak first of all increases directly as the pressure, and then increases more slowly as the pressure increases. The difference is least marked in hydrogen and most marked in carbonic acid. In hydrogen the rate of leak is nearly proportional to the pressure.

The relation between the rate of leak and the pressure depends also on the distance between the plates. The following few numbers are typical of the results obtained. There was a potential-difference of 200 volts between the plates and the rate of leak is given in scale-divisions per mm.

Pressure.	Rate of Leak.	
	Distance between plates 2.5 mm.	Distance between plates 15 mm.
mm. 187	11	47
376	21	83
752	41	127

For small distances between the plates the rate of leak is more nearly proportional to the pressure than for large distances.

The differences between the results for various gases and for different distances receive a simple explanation if we consider that the intensity of the radiation falls off rapidly between the plates on account of the absorption in the gas. The tables given for the relation between current and pressure, where the distance between the plates is small, show that when the absorption is small, the rate of leak varies directly as the pressure. For small absorption the intensity of the radiation is approximately uniform between the plates, and therefore the ionization of the gas is uniform throughout the volume of the gas between the plates. Since under a saturating electromotive force the rate of leak is proportional

to the total ionization, the above experiments show that the rate of production of the ions at any point is proportional to the pressure. It has been previously shown that the absorption of the radiation is approximately proportional to the pressure.

Let q = rate of production of the ions near the uranium surface for unit pressure.

λ_0 = coefficient of absorption of the gas for unit pressure.

The total number of ions produced between the plates, distant d apart, per unit area of the plate is therefore easily seen to be equal to

$$pq \int_0^d e^{-p\lambda_0 x} dx;$$

or to

$$\frac{q}{\lambda_0} \left(1 - e^{-p\lambda_0 d} \right),$$

since we have shown that the ionization and absorption are proportional to the pressure. If there is a saturating electromotive force acting on the gas, the ratio of the rate of leak at the pressure p_1 to that at the pressure p_2 is equal to the ratio r of the total number of ions produced at the pressure p_1 to the total number at pressure p_2 and is given by

$$r = \frac{1 - e^{-p_1 \lambda_0 d}}{1 - e^{-p_2 \lambda_0 d}}.$$

Now $p_1 \lambda_0$ is the coefficient of absorption of the gas for the pressure p_1 . If the absorption is small between the plates, $p_1 \lambda_0 d$ and $p_2 \lambda_0 d$ are both small and the value of r reduces to

$$r = \frac{p_1}{p_2},$$

or the rate of leak when the pressure is small is proportional to the pressure.

If the absorption is large between the plates at both the pressures p_1 and p_2 , the value of r is nearly unity—*i. e.* the rate of leak is approximately independent of the pressure. Experimental results on this point are shown graphically in fig. 7 (p. 138).

For intermediate values of the absorption, the value of r changes more slowly than the pressure.

With the same distance between the plates, the difference

between the curves (fig. 5) for air and hydrogen is due to the greater absorption of the radiation by the air. The less the absorption of the gas, the more nearly is the rate of leak proportional to the pressure. For carbonic acid the rate of leak decreases far more slowly with the pressure than for hydrogen; this is due partly to the much greater value of the absorption in carbonic acid and partly to the fact that 100 volts between the plates was not sufficient to saturate the gas.

If we take the rate of leak between two parallel plates some distance from the source of radiation, we obtain the somewhat surprising result that the rate of leak increases at first with diminution of pressure, although a saturating electromotive force is applied.

The arrangement used was very similar to that in fig. 3. The rate of leak was taken between the plates A and B, which were 2 cm. apart, and the plate A was about 1.5 cm. from the uranium surface. The following table gives the results obtained :—

Pressure.	Current.
mm.	
760	1
645	1.46
525	2
380	2.2
295	2.05
180	1.6
100	1.04
49	.58

The current at atmospheric pressure is taken as unity. The results are represented graphically in fig. 6.

The rate of leak reaches a maximum at a pressure of less than half an atmosphere, and then decreases, and at a pressure of 100 mm. the rate of leak is still greater than at atmospheric pressure.

This result is readily explained by the great absorption of the radiation at atmospheric pressure and the diminution of absorption with pressure.

Let d_1 = distance of plate A from the uranium.
 d_2 = " " B " "

With the notation previously used, the total ionization between A and B (on the assumption that the radiating surface is infinite in extent) is readily seen to be equal to

$$\frac{q}{\lambda} \left\{ e^{-p\lambda_0 d_1} - e^{-p\lambda_0 d_2} \right\}.$$

This is a function of the pressure, and is a maximum when

$$d_1 e^{-p\lambda_0 d_1} - d_2 e^{-p\lambda_0 d_2} = 0,$$

i. e. when

$$\log_e \frac{d_1}{d_2} = -p\lambda_0 (d_2 - d_1).$$

The value of $p\lambda_0$ for air at 760 mm. is 1.6.

Fig. 6.

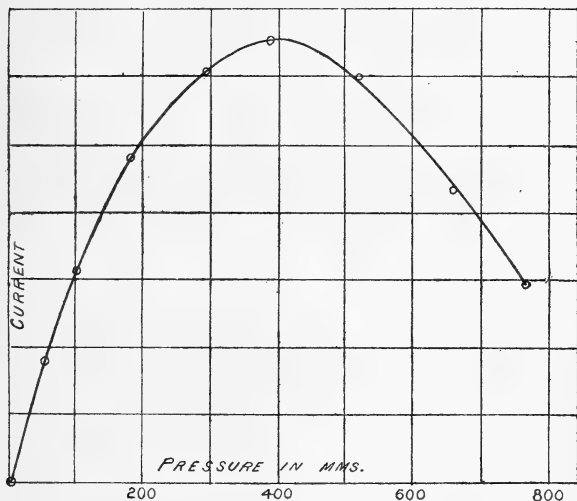

If $d_2=3$ cm., $d_1=1$, the leak is a maximum when the pressure is about $\frac{1}{3}$ of an atmosphere. On account of the large distance of the plates from the uranium surface in the experimental arrangements, no comparison between experiment and theory could be made.

In all the investigations on the relation between the pressure and the rate of leak, large electromotive forces have been used to ensure that the current through the gas is proportional to the total ionization of the gas. With low voltages the relation between current and pressure would be

very different, and would vary greatly with the voltage and distance between the electrodes as well as with the gas. It has not been considered necessary to introduce the results obtained for small voltages in this paper, as they are very variable under varying conditions. Although they may all be simply explained on the results obtained for the saturating electromotive forces they do not admit of simple calculation, and only serve to obscure the simple laws which govern the relations between ionization, absorption, and pressure. The general nature of the results for low voltages can be deduced from a consideration of the results given for the connexion (see § 16) between the current through the gas and the electromotive force acting on it at various pressures.

The above results for the relation between current and pressure may be compared with those obtained for Röntgen radiation. Perrin * found that the rate of leak varied directly as the pressure for saturating electromotive forces when the radiation did not impinge on the surface of the metal plates. This is in agreement with the results obtained for uranium radiation, for Perrin's result practically asserts that the ionization is proportional to the pressure. The results, however, of other experimenters on the subject are very variable and contradictory, due chiefly to the fact that in some cases the results were obtained for non-saturating electromotive forces, while, in addition, the surface ionization at the electrodes greatly complicated the relation, especially at low pressures.

§ 11. *Amount of Ionization in Different Gases.*

It has been shown that the α radiation from uranium is rapidly absorbed by air and other gases. In consequence of this the total amount of ionization produced, when the radiation is completely absorbed, can be determined.

The following arrangement was used:—A brass ball 2.2 cm. in diameter was covered with a thin layer of uranium oxide. A thin brass rod was screwed into it and the sphere was fixed centrally inside a bell-jar of 13 cm. diameter, the brass rod passing through an ebonite stopper. The bell-jar was fixed to a base-plate, and was made air-tight. The inside and outside of the bell-jar were covered with tinfoil. In practice an E.M.F. of 800 volts was applied to the outside of the bell-jar. The sphere, through the metal rod, was connected to one pair of quadrants of an electrometer. It was assumed that, with such a large potential-difference between the bell-jar and the sphere, the gas was approximately saturated and

* *Comptes Rendus*, cxxiii. p. 878.

the rate of movement of the electrometer-needle was proportional to the total number of ions produced in the gas. The following were some of the results obtained, the rate of leak due to air being taken as 100.

Gas.	Total Ionization.
Air	100
Hydrogen	95
Oxygen	106
Carbonic Acid	96
Coal-gas	111
Hydrochloric Acid Gas ...	102
Ammonia Gas	101

The results for hydrochloric acid and ammonia are only approximate, for it was found that both gases slightly altered the radiation emitted by the uranium oxide. For example, before the introduction of the gas the rate of leak due to air was found to be 100 divisions in 69 sec.; after the introduction of hydrochloric acid 100 divisions in 72 sec.; and with air again after the gas was removed 100 divisions in 74 sec.

The rate of leak is greatest in coal-gas and least in hydrogen, but all the gases tried show roughly the same amount of ionization as air. In the case considered both kinds of radiation emitted by uranium are producing ionization in the gas. By covering over the uranium oxide with a few layers of thin tinfoil it was found that, for the arrangement used, the rate of leak due to the penetrating ray was small in comparison with the rate of leak due to the α radiation.

The effect of diminution of the pressure on the rate of leak for air, hydrogen, and carbonic acid is shown in fig. 7, where the abscissæ represent pressure and the ordinates rate of leak. In the case of air and carbonic acid it was found that the rate of leak slightly increased at first with diminution of pressure. This was ascribed to the fact that even with 800 volts acting between the uranium and the surrounding conductor the saturation for atmospheric pressure was not complete. It will be observed that the rate of leak in air remains practically constant down to a pressure of 400 mm., and for carbonic acid down to a pressure of 200 mm. In hydrogen, however, the change of rate of leak with pressure is more rapid, and shows that all the radiation

emitted by the uranium was not completely absorbed at atmospheric pressure, so that the total ionization is probably larger than the value given in the table.

Fig. 7.

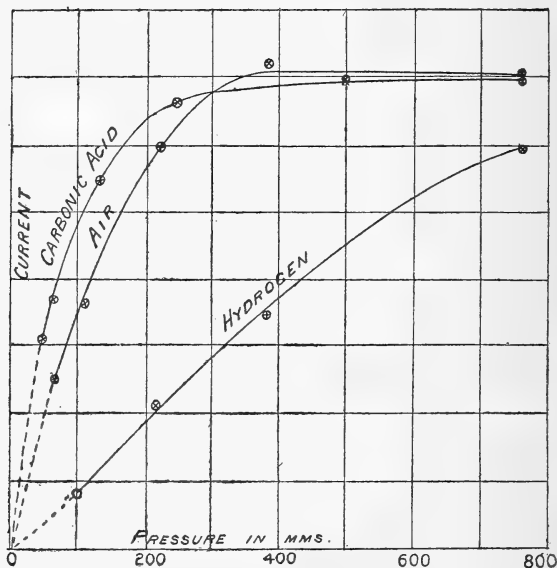

Assuming that there is the same energy of radiation emitted whatever the gas surrounding the uranium and that the radiation is almost completely absorbed in the gas, we see that there is approximately the same amount of ionization in all the gases for the same absorption of energy. This is a very interesting result, as it affords us some information on the subject of the relative amounts of energy required to produce ionization in different gases. In whatever process ionization may consist there is energy absorbed, and the energy required to produce a separation of the same quantity of electricity (which is carried by the ions of the gas) is approximately the same in all the gases tried.

From the results we have just given, it will be seen how indefinite it is to speak of the conductivity of a gas produced by uranium radiation. The ratio of the conductivities for different gases will depend very largely on the distance apart of the electrodes between which the rate of leak is observed. When the distance between the electrodes (*e. g.* two parallel plates) is small, the rate of leak is greater in

carbonic acid than in air, and greater in air than in hydrogen. As the distance between the plates is increased, these values tend to approximate equality. If, however, the rate of leak is taken between two plates some distance from the radiating surface (*e. g.* the plates A and B in fig. 3), the ratio of the rates of leak for different gases will depend on the distance of the plate A from the surface of the uranium. If the plate A is several centimetres distant from the uranium, the rate of leak will be greater with hydrogen than with air, and greater in air than in carbonic acid—the exact reverse of the other case. These considerations will also apply to what is meant by the conductivity of a gas for uranium radiation.

In a previous paper* I found the coefficient of absorption of a gas for Röntgen rays to be roughly proportional to the conductivity of the gas. The conductivity in this case was measured by the rate of leak between two plates close together and not far from the Crookes tube. The absorption in the air between the bulb and the testing apparatus was small. If it were possible to completely absorb the Röntgen radiation in a gas and measure the resulting conductivity, the total current should be independent of the gas in which the radiation was absorbed. This result follows at once if the absorption is proportional to the ionization produced for all gases. The results for uranium and Röntgen radiation are thus very similar in this respect.

§ 12. *Variation of the Current between two Plates with the Distance between them.*

The experimental arrangement adopted was similar to that in fig. 3 with the plate A removed. Two horizontal polished zinc plates 10 cm. in diameter were placed inside a bell-jar. The lower plate was fixed and covered with a uniform layer of uranium oxide, and the upper plate was movable, by means of a screw, parallel to the lower plate. The bell-jar was air-tight, and was connected with an air-pump. The lower plate was connected to one pole of a battery of 200 volts, the other pole of which was earthed, and the insulated top plate was connected with the electrometer. The exterior surface of the glass was covered with tinfoil connected to earth.

The following table gives the results of the variation of the rate of leak with distance for air at pressures of 752, 376, and 187 mm. The results have been corrected for change of

* *Phil. Mag.* April 1897.

140 Prof. E. Rutherford on Uranium Radiation and the capacity of the electrometer circuit with movement of the plates.

Distance between plates.	Rate of leak in scale-divisions per min.		
	752 mm.	376 mm.	187 mm.
mm. 2.5	41	21	
5	70	40	20
7.5	92	53	
10	109	65	36
12.5	123	76	
15	128	83	47

The results are shown graphically in fig. 8, where the
Fig. 8.

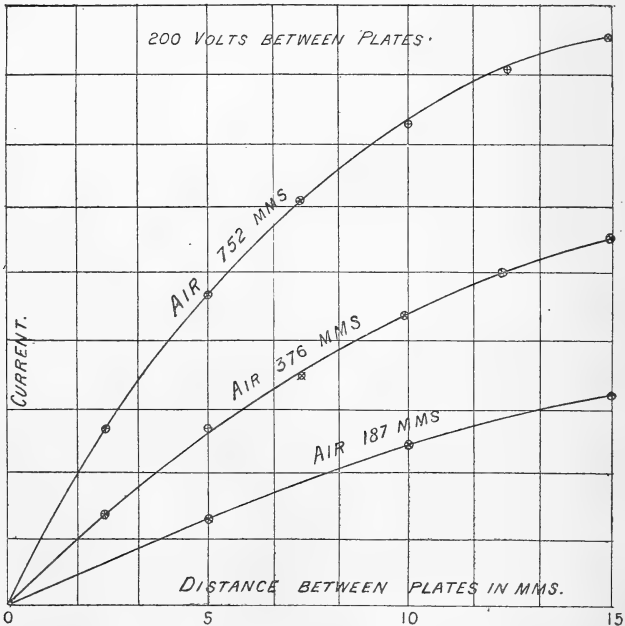

abscissæ represent distances between the plates and the ordinates rates of leak. The values given above correspond to saturation rates of leak ; for 200 volts between the plates is

sufficient to very approximately saturate the gas even for the greatest distance apart of 1.5 cm.

It will be observed that the rate of leak increases nearly proportionally to the distance between the plates for short distances, but for air at atmospheric pressure increases very slowly with the distance when the distances are large.

If there were no appreciable absorption of the radiation by the gas, the ionization would be approximately uniform between the plates, provided the diameter of the uranium surface was large compared with the greatest distance between the plates. The saturation rate of leak would in that case vary as the distance. If there is a large absorption of the radiation by the gas, the ionization will be greatest near the uranium and will fall off rapidly with the distance. The saturation rate of leak will thus increase at first with the distance, and then tend to a constant value when the radiation is completely absorbed between the plates.

The results given in the previous table allow us to determine the absorption coefficient of air at various pressures. My attention was first drawn to the rapid absorption of the radiation by experiments of this kind.

The number of ions produced between two parallel plates distant d apart is equal to

$$pq \int_0^d e^{-p\lambda_0 x} dx,$$

i. e., to

$$\frac{q}{\lambda_0} (1 - e^{-p\lambda_0 d}),$$

assuming the ionization and the absorption are proportional to the pressure. The notation is the same as that used in § 10.

For the pressure p the saturation rate of leak between the plates is thus proportional to $1 - e^{-p\lambda_0 d}$.

If p and d are varied so that $p \times d$ is a constant, the rate of leak should be a constant. This is approximately true as the numbers previously given (see fig. 8) show. It must, however, be borne in mind that the conditions, on which the calculations are based, are only approximately fulfilled in practice, for we have assumed the uranium surface to be infinite in extent and that the saturation is complete.

The variation of the rate of leak with distance agrees fairly closely with the theory. When $p\lambda_0 d$ is small the rate of leak is nearly proportional to the distance between the plates and the pressure of the gas. When $p\lambda_0 d$ is large the rate of leak varies very slowly with the distance.

The value of $p\lambda_0$ can be deduced from the experimental results, so that we have here an independent method of determining the absorption of the radiation at different pressures.

The lower the pressure the more uniform is the ionization between the plates, so that the saturation rate of leak at low pressures is nearly proportional to the distance between the plates. This is seen to be the case in fig. 8, where the curve for a pressure of 187 mm. is approximately a straight line. Similar results have been obtained for hydrogen and carbonic acid.

§ 13. Rate of Recombination of the Ions.

Air that has been blown by the surface of a uranium compound has the power of discharging both positive and negative electrification. The following arrangement was used to find the duration of the after-conductivity induced by uranium radiation:—A sheet of thick paper was covered over with a thin layer of gum-arabic, and then uranium oxide or uranium potassium sulphate in the form of fine powder was sprinkled over it. After this had dried the sheet of paper was formed into a cylinder with the uranium layer inside. This was then placed in a metal tube T (fig. 9) of 4 cm. diameter. A

Fig. 9.

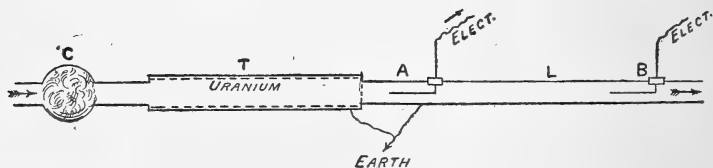

blast of air from a gasometer, after passing through a plug C of cotton-wool to remove dust, passed through the cylinder T and then down a long metal tube connected to earth.

Insulated electrodes A and B were fixed in the metal tube. The electrometer could be connected to either of the electrodes A or B. In practice the quadrants of the electrometer were first connected together. The electrode A or B and the electrometer were then charged up to a potential of 30 volts, and the quadrants then separated.

When the uranium was removed there was no rate of leak at either A or B when a rapid current of air was sent through the tube. On replacing the uranium cylinder and sending a current of air along the tube, the electrometer showed a

gradual loss of charge which continued until the electrode was discharged.

When the electrode A was charged to 30 volts there was no rate of leak of B. The rate of leak of B or A is thus proportional to total number of ions in the gas. The ions recombine in the interval taken for the air to pass between A and B. The rate of leak of B for a saturating voltage, when A is to earth, is thus less than that of A.

For a particular experiment the rate of leak of the electrode A was 146 divisions per minute. When A was connected to earth, the saturation rate of leak of B was 100 divisions per minute. The distance between A and B was 44 cm., and the mean velocity of the current of air along the tube 70 cm. per second. In the time, therefore, of .63 sec. the conductivity of the gas has fallen to .68 of its value.

If we assume, as in the case of Röntgenized air *, that the loss of conductivity is due to the recombination of the ions, the variation of the number with the time is given by

$$\frac{dn}{dt} = -\alpha n^2,$$

where n is the number of ions per c.c. and α a constant. If N is the number of ions at the electrode A, the number of ions n at B after an interval t is given by

$$\frac{1}{n} - \frac{1}{N} = \alpha t.$$

Now the saturating rates of leak at A and B are proportional to N and n , and it can readily be deduced that the time taken for the number of ions to recombine to half their number is equal to 1.3 sec. This is a much slower rate of recombination than with Röntgenized air near an ordinary Crookes tube.

The amount of ionization by the uranium radiation is in general much smaller than that due to Röntgen rays, so that the time taken for the ions to fall to half their number is longer.

The phenomenon of recombination of the ions is very similar in both uranium and Röntgen conduction. In order to test whether the rate of recombination of the ions is proportional to the square of the number present in the gas, the following experiment was performed :—

* *Phil. Mag.* Nov, 1897.

A tube A (fig. 10) was taken, 3 metres long and 5.5 cm. in diameter. A cylinder D, 25 cm. long, had its interior surface coated with uranium oxide. This cylinder just fitted the large tube, and its position in the tube could be varied by means of strings attached to it, which passed through corks at the ends of the long tube. The air was forced

Fig. 10.

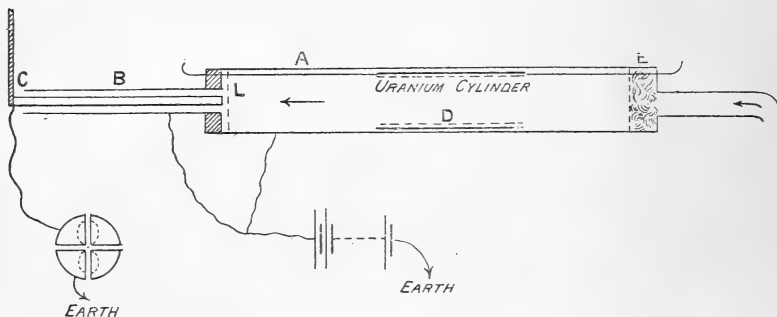

through the tube from a gasometer, and on entering the tube A passed through a plug of cotton-wool, E, in order to remove dust from the air and to make the current of air more uniform over the cross-section of the tube. The air passed by the uranium surface and then through a gauze L into the testing cylinder B of 2.8 cm. diameter. An insulated rod C, 1.6 cm. in diameter, passed centrally through the cylinder B and was connected with the electrometer. The cylinders A and B were connected to one pole of a battery of 32 volts, the other pole of which was to earth.

The potential-difference of 32 volts between B and C was sufficient to almost completely remove all the ions from the gas in their passage along the cylinder. The rate of leak of the electrometer was thus proportional to the number of ions in the gas.

The following rates of leak were obtained for different distances of the uranium cylinder from the gauze L (table, p. 145).

The first column of the table gives the distances of the end of the uranium cylinder from the gauze L. d (about 20 cm.) was the distance for which the first measurement was made. In the second column the time intervals taken for the air to pass over the various distances are given. The value of t corresponds to the distance d . The mean velocity of the current of air along the tube was about 25 cm. per sec.

Distance of Uranium cylinder from L.	T.	Rate of leak in scale-divisions per minute.	Calculated rates of leak.
d	t	*159	*159
$d+25$ cm.	$t+1$ sec.	111	112
$d+50$ „	$t+2$ „	* 87	* 87
$d+100$ „	$t+4$ „	62	60
$d+200$ „	$t+8$ „	39	37

In the third column are given the observed rates of leak, and in the fourth column the calculated values.

The values were calculated on the assumption that the rate of recombination of the ions was proportional to the square of the number present, *i. e.* that

$$\frac{dn}{dt} = -\alpha n^2,$$

where n is the number of ions present and α is a constant. The two numbers with the asterisk were used to determine the constants of the equation. The agreement of the other numbers is closer than would be expected, for in practice the velocity of the blast is not constant over the cross-section, and there is also a slight loss of conductivity of the gas due to the diffusion of the ions to the side of the long tube.

It will be observed that the rate of recombination is very slow when a small number of ions are present in the gas, and that the air preserves one quarter of its conducting power after an interval of 8 seconds.

§ 14. *Velocity of the Ions.*

The method* adopted to determine the velocity of the ions in Röntgen conduction cannot be employed for uranium conduction. It is not practicable to measure the rate of recombination of the ions between the plates on account of the very small after-conductivity in such a case; and, moreover, the inequality of the ionization between the two plates greatly disturbs the electric field between the plates.

A comparison of the velocities, under similar conditions, of the ions in Röntgen and uranium conduction can, however,

* *Phil. Mag.* Nov. 1897.

be readily made. The results show that the ions in the two types of conduction are the same.

In order to compare the velocities an apparatus similar to fig. 10 was used. The ions were blown by a charged wire A, and the conductivity of the gas tested immediately afterwards at an electrode B, which was fixed close to A. The electrode A was cylindrical and fixed centrally in the metal tube L, which was connected to earth. For convenience of calculation it is assumed that the electric field between the cylinders is the same as if the cylinders were infinitely long.

Let a, b be the radii of the electrode A and the tube L (internal);

Let V be the potential of A (supposed positive).

The electromotive intensity X (without regard to sign) at a distance r from the centre of the tube is given by

$$X = \frac{V}{r \log_e \frac{b}{a}}$$

Let u_1, u_2 be the velocities of the positive and negative ions for a potential gradient of 1 volt per cm. If the velocity is proportional to the electric force at any point, the distance dr traversed by the negative ion in the time dt is given by

$$dr = Xu_2 dt,$$

or

$$dt = \frac{\log_e \frac{b}{a} r dr}{Vu_2}.$$

Let r_2 be the distance from the centre from which the negative ion can just reach the electrode in the time t taken for the air to pass along the electrode.

Then

$$t = \frac{(r_2^2 - a^2)}{2Vu_2} \log_e \frac{b}{a}.$$

If ρ_2 be the ratio of the number of the negative ions that reach the electrode A to the total number passing by,

then

$$\rho_2 = \frac{r_2^2 - a^2}{b^2 - a^2}.$$

Therefore

$$u_2 = \frac{\rho_2(b^2 - a^2) \log_e \frac{b}{a}}{2V \cdot t} \dots \dots \dots (1)$$

Similarly the ratio ρ_1 of the number of positive ions that give up their charge to the external cylinder to the total number is given by

$$u_1 = \frac{\rho_1(b^2 - a^2) \log_e \frac{b}{a}}{2V \cdot t} \dots \dots \dots (2)$$

In the above equations it is assumed that the current of air is uniform over the cross-section of the tube, and that the ions are uniformly distributed over the cross-section; also, that the movement of the ions does not appreciably disturb the electric field. Since the value of t can be calculated from the velocity of the current of air and the length of the electrode, the values of the velocities of the ions under unit potential gradient can at once be determined.

The equation (1) shows that ρ_2 is proportional to V ,—*i. e.* that the rate of leak of the electrode A varies directly as the potential of A, provided the value of V is not large enough to remove all the ions from the gas as it passes by the electrode. This was experimentally found to be the case.

In the comparison of the velocities the potential V was adjusted to such a value that ρ_2 was about one half. This was determined by testing the rate of leak at B with a saturating electromotive force. The amount of recombination of the ions between the electrodes A and B was very small, and could be neglected.

The uranium cylinder was then removed, all the other parts of the apparatus remaining unchanged. An aluminium cylinder was substituted for the uranium cylinder, and x -rays were allowed to fall on the aluminium. The bulb and induction-coil were placed in a metal box in order to carefully screen off all electrostatic disturbances. The rays were only allowed to fall on the central portion of the cylinder. The intensity of the rays was adjusted so that, with the same current of air, the rate of leak was comparable with that produced by the uranium. It was then found that the value of ρ_2 was nearly the same as for the uranium conduction. For example, the rate of leak of B was reduced from 38 to 14 scale-divisions per min. by charging A to a certain small potential, when the air was blown by the surface of the uranium. When Röntgenized air was substituted, the rate of leak was reduced from 50 to 18 divisions per min. under the same conditions. The values of ρ_2 were $\cdot 63$ and $\cdot 64$ respectively. This agreement is closer than would be expected, as the bulb was not a very steady source of radiation.

This result shows that the ions in Röntgen and uranium conduction move with the same velocity and are probably identical. The velocity of an ion in passing through a gas is proportional to $\frac{e}{m}$, where e is the charge carried by the ion, and m its mass. Unless e and m vary in the same ratio it follows that the charge carried by the ion in uranium and Röntgen conduction is the same, and also that their masses are equal.

It was found that the velocity of the negative ion was somewhat greater than that of the positive ion. This has been shown to be the case for ions produced by Röntgen rays*. The difference of velocity between the positive and negative carrier is readily shown. The rate of leak of B is observed when charged positively and negatively. When B was charged positively the rate of leak measured the number of negative ions that escaped the electrode A, and when charged negatively the number of positive ions. The rate of leak was always found to be slightly greater when B was charged negatively. This is true whether A is charged positively or negatively, and shows that there is an excess of positive ions in the gas after passing by the electrode A.

The difference of velocities of the ions can also readily be shown by applying an alternating electromotive force to the electrode A sufficient to remove a large proportion of the ions as the air passes by. The issuing gas is always found to be positively charged, showing that there is an excess of positive over negative ions.

A large number of determinations of the velocities of the uranium ions have been made, with steady and alternating electromotive forces, when the air passed between concentric cylinders or plane rectangular plates. In consequence of the inequality of the velocity of the current of air over the cross-section of the tube, and other disturbing factors which could not be allowed for, the determination could not be made with the accuracy that was desired. For an accurate determination, a method independent of currents of air is very desirable.

§ 15. *Potential Gradient between two Plates.*

The normal potential gradient between two plates is altered by the movement of the ions in the electric field.

Two methods were used to determine the potential gradient.

* Zeleny, Phil. Mag. July 1898.

In the first method a thin wire or strip was placed between two parallel plates one of which was covered with uranium. The wire was connected with the electrometer, and after being left some time took up the potential in the air close to the wire. In the second method the ordinary mercury- or water-dropper was employed to measure the potential at a point.

For the first method two large zinc plates were taken and placed horizontal and parallel to one another. A layer of uranium oxide was spread over the lower plate. The bottom plate was connected to one pole of a battery of 8 volts, and the top plate was connected to earth. An insulated thin zinc strip was placed between the plates and parallel to them. The strip was connected with the electrometer, and gradually took up the potential of the point. By moving the strip the potential at different points between the plates could be determined.

The following table is an example of the results obtained.

Plates 4.8 cm. apart ; 8 volts between plates.

Distance from top plate.	Potential in volts with Uranium.	Potential in volts without Uranium.
0	0	0
.6	2.5	1
1.2	3.8	2
2.1	5.9	3.5
3.1	7	5.2
4.8	8	8

The third column is calculated on the assumption that without the uranium the potential falls off uniformly between the plates.

The method given above is not very satisfactory when the strip is close to the plates, as it takes up the potential of the point very slowly.

The water- or mercury-dropper was more rapid in its action, and gave results very similar to those obtained by the first method. Two parallel brass plates were placed vertically and insulated. One plate was connected to the positive and

the other to the negative pole of a battery. The middle point of the battery was placed to earth. The water-dropper was connected with the electrometer. The potential at a point was first determined without any uranium near. One plate was then removed, and an exactly similar plate, covered with the uranium compound, substituted. The potential of the point was then observed again. In this way the potential at any point with and without the uranium could be determined. The curve shown in fig. 11 is an example of the potential gradient observed between two parallel plates 6.6 cm. apart. The dotted line represents the potential gradient when the uranium is removed. The ordinates represent volts and the abscissæ distances from the plate covered with the uranium compound.

Fig. 11.

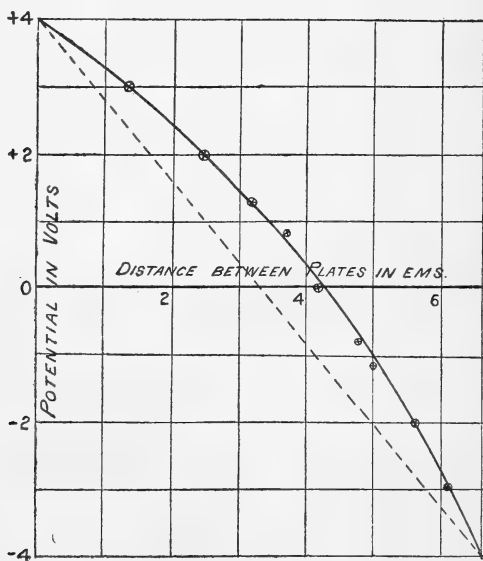

It will be observed that the potential gradient is diminished near the uranium and increased near the other plate. The point of zero potential is displaced away from the uranium.

From curves showing the potential gradient between two plates, the distribution of free electrification between the plates can be deduced. By taking the first differential of the curve we obtain $\frac{dv}{dx}$, the electric force at any point, and by taking the second differential of the curve we obtain $\frac{d^2v}{dx^2}$, which is

equal to $-4\pi\rho$, where ρ is the volume-density of electrification at any point. In order to produce the disturbance of the electric field shown in fig. 11, there must be an excess of ions of one kind distributed between the plates. Such a result follows at once from what has been said in regard to the inequality of the ionization between the plates due to the absorption of the radiation.

It was found that the potential gradient approached more and more its undisturbed value with increase of the electromotive force between the plates. The displacement of the point of zero-potential from the uranium surface increased with diminution of electromotive force. For example, for two plates 51 mm. apart, charged to equal and opposite potentials, the points of zero potential were 28, 30, 33 mm. from the uranium when the differences of potential between the plates were 16, 8, and 4 volts respectively.

When the uranium was charged positively, the point of zero potential was more displaced than when it was charged negatively. This is due to the slower velocity of the positive ion.

The slope of potential very close to the surface of the uranium has not been investigated. The deviation from the normal potential slope between the plates depends very largely on the intensity of the ionization produced in the gas. With very weak ionization the normal potential gradient is only slightly affected.

Child* and Zeleny† have shown that the potential gradient between two parallel plates exposed to Röntgen rays is not uniform. In their cases the ionization was uniform between the plates, and the disturbance in the field manifested itself in a sudden drop at both electrodes. In the case considered for uranium radiation, the ionization is too small for this effect to be appreciable. The disturbance of the field is due chiefly to the inequality of the ionization, and does not only take place at the electrodes.

§ 16. *Relation between Current and Electromotive Force.*

The variation with electromotive force of the current through a gas exposed to uranium radiation has been investigated by Becquerel‡, and later by de Smolan and Beattie§.

* Wied. *Annal.* April 1898, p. 152.

† *Phil. Mag.*, July 1898.

‡ *Comptes Rendus*, pp. 438, 800 (1897).

§ *Phil. Mag.* vol. xliii. p. 418 (1897).

The general relation between the current through the gas and the E.M.F. acting on it is very similar to that obtained for gases exposed to Röntgen radiation. The current at first increases nearly proportionally with the E.M.F. (provided the E.M.F.'s of contact between the metals are taken into account), then more slowly, till finally a stage is reached, which may be termed the "saturation stage," where there is only a very slight increase of current with a very large increase of electromotive force. As far as experiments have gone, uranium oxide, when immersed in gases which do not attack it, gives out a constant radiation at a definite temperature, and the variation of the intensity of radiation with the temperature over the ordinary atmospheric range is inappreciable. For this reason it is possible to do more accurate work with uranium radiation than with Röntgen radiation, for it is almost impossible to get a really steady source of x -rays for any length of time.

It was the object of these experiments to determine the relation between current and electromotive force with accuracy, and to see whether the gas really becomes saturated; *i. e.*, whether the current appreciably increases with electromotive forces when the electromotive forces are great, but still not sufficient to break down the gas and to produce conduction in the gas without the uranium radiation.

A null method was devised to measure the current, in order to be independent of the electrometer as a measuring instrument and to merely use it as an indicator of difference of potential.

Fig. 12.

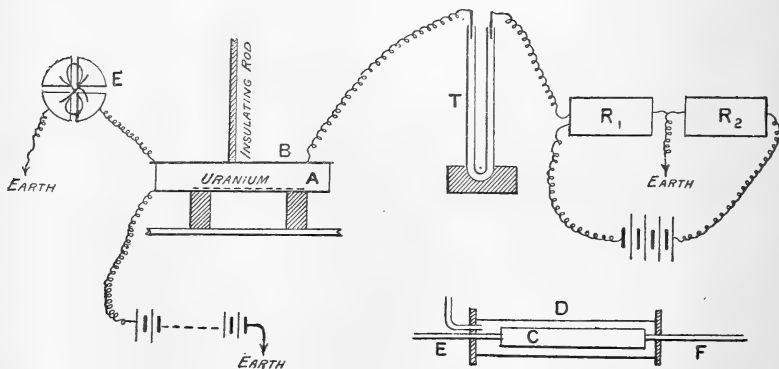

Fig. 12 shows the general arrangement of the experiment. A and B were two insulated parallel zinc plates: on the lower

plate A was spread a uniform layer of uranium oxide. The bottom plate was connected to one pole of a battery of a large number of storage-cells, the other pole of which was to earth. The insulated plate B was connected to one pair of quadrants of an electrometer, the other pair of which was to earth. Under the influence of the uranium the air between the plates A and B is made a partial conductor, and the potential of B tends to become equal to that of A. In order to keep the potential of B at zero, B is connected through a very high resistance T of xylol, one end of which is kept at a steady potential. If the amount of electricity supplied to B through the xylol by the battery is equal and opposite in sign to the quantity passing between A and B, the potential of B will remain steadily at zero. In order to adjust the potential to be applied to one end of the xylol-tube T, a battery was connected through resistance-boxes R_1 R_2 , the wire between being connected to earth. The ratio of the E.M.F. e acting on T to the E.M.F. E of the battery is given by

$$\frac{e}{E} = \frac{R_1}{R_1 + R_2}.$$

In practice $R_1 + R_2$ was always kept constant and equal to 10,000 ohms, and, in adjusting the resistance, plugs taken from one box were transferred to the other. The value of e is thus proportional to R_1 , and the amount of current supplied to B (assuming xylol obeys Ohm's Law) is proportional to R_1 . If the resistances are varied till the electrometer remains at the "earth zero," the current between the plates is proportional to R_1 . If the value of the E.M.F. applied is too great the needle moves in one direction, if too small in the opposite direction. For fairly rapid leaks the current could be determined to an accuracy of 1 per cent.; but for slow electromotive leaks this accuracy is not possible on account of slow changes of the electrometer zero when the quadrants are disconnected.

The following tables show the results of an experiment with uranium oxide. The surface of the uranium was 14 cm. square. In order to get rid of stray radiation at the sides lead strips, which nearly reached to the top plate, were placed round the uranium. 16 volts were applied to the resistance-box, and a resistance of 10,000 ohms kept steadily in the circuit.

Plates 2.5 cm. apart.		Plates .5 cm. apart.	
Volts.	Current R_1 .	Volts.	Current R_1 .
.5	425	.125	1400
1	825	.25	2800
2	1570	.5	4300
4	2750	1	5250
8	3750	2	5650
16	4230	4	6200
37.5	4700	8	6670
112	5250	16	6950
375	5625	100	7400
800	5825	335	7850

Under the column of volts the difference of potential between A and B is given. The current is given in terms of the resistance R_1 required to keep the electrometer at the earth zero. It will be observed that for the first few readings Ohm's Law is approximately obeyed, and then the current increases more gradually till for large E.M.F.'s the rate of increase is very slow. For the plates .5 cm. apart the rate of leak for 335 volts is only 50 per cent. greater than the rate of leak for 1 volt.

The same general results are obtained if the surface of the uranium is bare or covered with thin metal. The disadvantages of covering the surface with thin tin or aluminium foil are (1) that the intensity of the radiation is considerably decreased; (2) that the ions diffuse from under the tinfoil through any small holes or any slight openings in the side. The drawback of using the uncovered uranium in the form of fine powder, is that under large electric forces the fine uranium particles are set in motion between the plates and cause an additional leakage. In practice the rate of leak was measured with potential-differences too small to produce any appreciable action of this kind.

In order to investigate the current-electromotive-force relations for different gases the same method was used, but the leakage in this case took place between two concentric cylinders. The apparatus is shown in the lower part of fig. 12: C and D were two concentric cylinders of brass 4.5 and 3.75 cm. in diameter, insulated from each other.

The ends of the cylinder D were closed by ebonite collars, and the central cylinder was supported in position by brass rods passing through the ebonite. The surface C was uniformly covered with uranium oxide. The cylinder D was connected to one pole of a battery, the other pole of which was to earth. The cylinder C was connected to the electrometer. The following tables show the results obtained for hydrogen, carbonic acid, and air. Distance between cylinders .375 cm.

Hydrogen.

Carbonic Acid.

Air.

Volts.	Current.
0	122
-.062	125
.125	123
.25	142
.5	150
1	160
2	163
4	165
8	168
16	172
108	178
216	185

Volts.	Current.
0	95
-.125	205
.25	255
.5	305
1	355
2	405
4	460
8	520
16	590
36	705
108	787
216	820

Volts.	Current.
+1	418
2	451
4	495
8	533
36	601
108	615
216	630

The above results are expressed graphically in fig. 13, where the ordinates represent current on an arbitrary scale and the abscissæ volts. In the tables given for hydrogen and carbonic acid it will be observed that the current has a definite value when there is no external electromotive force acting. The reason for this is probably due to the *contact* difference of potential between the uranium surface and the interior brass surface of the outside cylinder. When the external cylinder was connected to earth the inside cylinder became charged* to $-.12$ volt after it was left a short time.

* This phenomenon has been studied by Lord Kelvin, Beattie, and S. de Smolan, and it has been shown that metals are charged up to small potentials under the influence of uranium radiation. The steady difference of potential between two metal plates between which the radiation falls is the same as the *contact* difference of potential. An exactly similar phenomenon has been studied by Perrin (*Comptes Rendus*, cxxiii. p. 496) for α -rays.

In consequence of this action, for small electromotive forces the rates of leak are different for positive and negative.

Fig. 13.

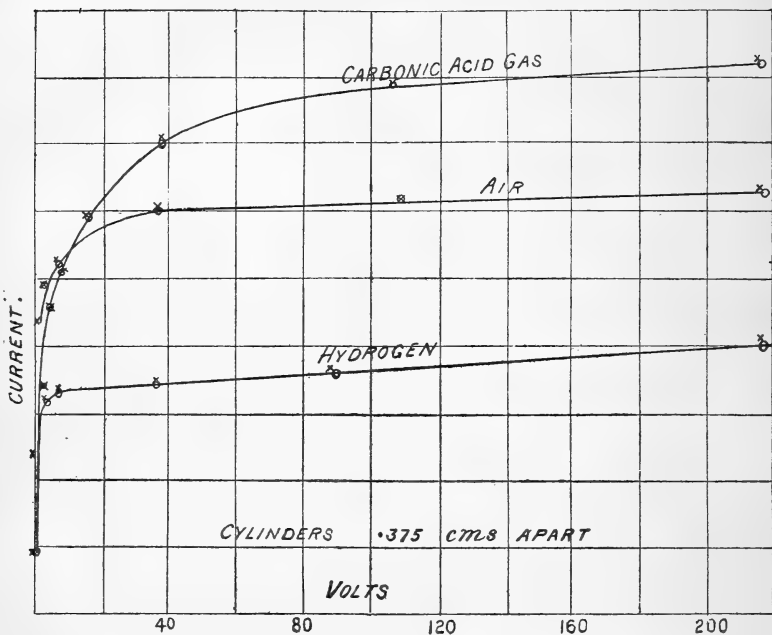

Results of this kind are shown more clearly in fig. 14, which gives the current-electromotive-force curves for hydrogen and carbonic acid for small voltages. When there is no external electromotive force acting, the current has a fixed value; if the uranium is charged positively, the current increases slowly with the voltage; when the uranium is charged negatively, the current is at first *reversed*, becomes zero, and rapidly increases with the voltage until for about 1 volt between the plates the positive and negative currents are nearly equal. The curve for carbonic acid with a positive charge on the uranium is also shown. It will be seen that the initial slope of the curve is greater for carbonic acid than for hydrogen.

It is remarkable that the current with zero E.M.F. for hydrogen is about two-thirds of its value when 216 volts are acting between the plates. The ions in hydrogen diffuse more rapidly than in air, and in consequence a large proportion

of the negative ions reach the uranium and give up their charge to it before recombination can take place.

Fig. 14.

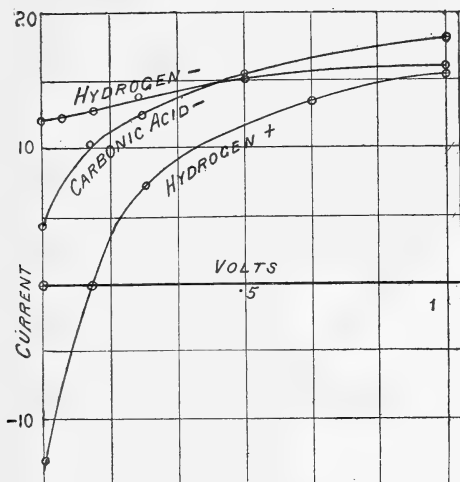

If the radiation fell between two plates of exactly the same metal, the inequality between the positive and negative current values for low voltages would almost disappear, but even in that case there would still be an apparent current through the gas, due to the fact that the negative carriers diffuse with greater rapidity than the positive. Effects of this kind have been studied for Röntgen radiation by Zeleny*.

For large E.M.F.'s no appreciable difference in the value of the current could be detected whether the uranium was positively or negatively charged, *i. e.* positive and negative electrifications are discharged with equal facility.

For the different gases the current tends more rapidly to a saturation value in hydrogen than in air, and more rapidly in air than in carbonic acid. In all these cases there is still a slight increase of current with increase of E.M.F. long after the "knee" of the saturation curve has been passed, and in no case has complete saturation been observed at atmospheric pressure, even for a potential gradient of 1300 volts per cm.

The explanation of the general form of the curves showing the relation between current and electromotive force for ionized gases has been given in a previous paper†. In the

* Phil. Mag., July 1898.

† J. J. Thomson and E. Rutherford, Phil. Mag. November 1896.

case of uranium conduction the phenomenon is still further complicated by the want of uniformity of ionization between the plates and the resulting disturbance of the electrostatic field due to the excess of ions of one kind between the plates.

The ionization of the gas is greatest near the uranium surface, and falls off rapidly with the distance. The rate of recombination of the ions thus varies from point to point between the plates, being greatest near the surface of the uranium.

The equations which express completely the relation between the current and electromotive force for the rate of leak between two parallel plates, one of which is covered with uranium, are very complex and cannot be expressed in simple form. The disturbance of the electrostatic field between the plates, due to the movement of the ions, has to be considered as well as the variable rates of recombination at the different points, and the difference of velocity between the positive and negative ions.

The great difficulty in producing complete saturation, *i. e.* to reach a stage when all the ions produced reach the electrodes, may be due to one or more of three causes:—

(1) Rapid rate of recombination of the ions very near the surface of the uranium.

(2) Presence of very slow moving ions together with the more rapidly moving carriers.

(3) An effect of the electric field on the production of the ions.

The effect of (3) is probably very small, for there is no experimental evidence of any such action unless the electromotive forces are very high. That the slow increase of the current in strong fields is due to (1) rather than (2) receives some support from an experiment that has been recently tried. Instead of measuring the current with the uranium covering one electrode, the air which had passed over uranium was forced between two concentric cylinders between which the electromotive force was acting. The rate of leak was found to only increase 2 or 3 per cent. when the E.M.F. was increased from 16 to 320 volts. This increase is much smaller than in the results previously given. Since the effect of (2) would be present in both cases, this experiment seems to show that the difficulty in removing all the ions from the gas is not due to the presence of some very slow-moving carriers.

Effect of Pressure.

Some current electromotive-force curves for small voltages have been obtained at different pressures. Examples of the results are shown in fig. 15, which gives the relation between the current and the electromotive force at pressures of 760, 380, 190, and 95 mm. of mercury.

These results were obtained with a different apparatus and by a different method to that given in fig. 12. Two parallel insulated metal plates, about 3 cm. apart, one of which was covered with uranium oxide, were placed inside an air-tight vessel. One plate was connected to earth and the other to the electrometer. The plate connected to the electrometer was then charged up to a potential of 10 volts. On account of the presence of the uranium oxide the charge slowly leaked away, and the rate of movement of the electrometer-needle measured the current corresponding to different values of the electromotive force.

Fig. 15.

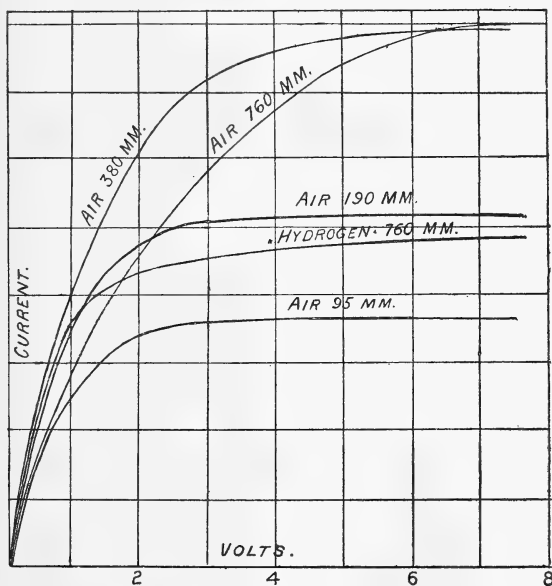

The method did not admit of the accuracy of that previously employed (see fig. 12). The rate of leak for small fractions of a volt could not be determined, so that in the curves fig. 15 it is assumed that the current was zero when the electromotive force was zero. This is probably not quite

accurate owing to the slight contact-difference of potential between the plates, so that there was a small initial current for zero external electromotive force.

The general results show that the gas tends to become more readily saturated with diminution of pressure. The variation of the current with the E.M.F. depends on two factors—the velocities of the ions, and their rate of recombination. Some experiments on the velocity of the carriers* in ultra-violet light conduction showed that the velocity of the ions in a given electric field is inversely proportional to the pressure. This is probably also true for the ions in Röntgen conduction; so that under the pressure of 95 mm. the ions would move eight times as fast as at atmospheric pressure. The variation of the rate of recombination with pressure has not yet been determined.

The curve for hydrogen at atmospheric pressure is also given in fig. 15, and shows that hydrogen is about as easily saturated as air at 190 mm. pressure.

§ 17. *Separation of the Positive and Negative Ions.*

It is a simple matter to partially separate the positive and negative ions in uranium conductions and produce an electrified gas. The subject of the production of electrification by passing a current of air over the surface of uranium enclosed in a metal vessel has been examined by Beattie †, who found the electrification obtained was of the same sign as the charge on the uranium. His results admit of a simple explanation on the theory of ionization. The gas near the surface of the uranium is far more strongly ionized than that some distance away on account of the rapid absorption of the radiation by the air. For convenience of explanation, let us suppose a piece of uranium, charged positively, placed inside a metal vessel connected to earth, and a current of air passed through the vessel. Under the influence of the electromotive force the negative ions travel in towards the uranium, and the positive ions towards the outer vessel. Since the ionization is greater near the surface of the uranium, there will be an excess of positive ions in the air some distance away from the uranium. Part of this is blown out by the current of air, and gives up its charge to a filter of cotton-wool. The total number of negative ions blown out in the same time is much less, as the electromotive intensity, and therefore the velocity of the carrier, is greater near the uranium than near the outside cylinder. Consequently there is an excess of positive

* Proc. Camb. Phil. Soc. Feb. 21, 1888.

† Phil. Mag. July 1897, xliv. p. 102.

ions blown out, and a positively electrified gas is obtained. As the potential-difference between the electrodes is increased, the amount of electrification obtained depends on two opposing actions. The velocity of the carriers is increased, and consequently the ratio of the number of carriers removed is diminished. But if the gas is not saturated, with increase of electromotive force the number of ions travelling between the electrodes is increased, and for small voltages this increase more than counterbalances the diminution due to increase of velocity. The amount of electrification obtained will therefore increase at first with increase of voltage, reach a maximum, and then diminish; for when the gas is saturated no more ions can be supplied with increase of electromotive force. This is exactly the result which Beattie obtained, and which I also obtained in the case of the separation of the ions of Röntgenized air. The fact that more positive than negative electrification is obtained is due to the greater velocity with which the negative ion travels. (See § 14.)

The properties of this electrified gas are similar to that which has been found from Röntgen conduction. The *opposite sign* of the electrification obtained by Beattie for uranium induction, and by myself for Röntgen conduction*, is to be expected on account of the different methods employed. For obtaining electrification from Röntgenized air a rapid current of air was directed close to the charged wire. In that case the sign of the electrification obtained is opposite to that of the wire, as it is the carriers of opposite sign to the wire which are blown out before they reach the wire. In the case of uranium the current of air filled the cross-section of the space between the electrodes; and it has been shown that under such conditions electrification of the same sign as the uranium is to be expected.

§ 18. *Discharging-power of Fine Gauzes.*

Air blown over the surface of uranium loses all trace of conductivity after being forced through cotton-wool or through any finely divided substance. In this respect it is quite similar to Röntgenized air. The discharging-power of cotton-wool and fine gauzes is at first sight surprising, for there is considerable evidence that the ions themselves are of molecular dimensions, and might therefore be expected to pass through small orifices; but a little consideration shows that the ions, like the molecules, are continually in rapid motion, and, in addition, have free charges, so that whenever they approach within a certain distance of a solid body they tend to be attracted towards it, and give up their charge or adhere to

* Phil. Mag. April 1897.

the surface. On account of the rapidity of diffusion* of the ions, the discharging-power of a metal gauze, with openings very large compared with the diameter of a carrier, may be considerable. The table below gives some results obtained for the discharging-power of fine copper gauze. The copper gauze had two strands per millim., and the area occupied by the metal was roughly equal to the area of the openings. The gauzes filled the cross-section of the tube at A (fig. 9), and were tightly pressed together. The conductivity of the air was tested after its passage through the gauzes, the velocity of the air along the tube being kept approximately constant. The rates of leak per minute due to the air after its passage through different numbers of gauzes is given below.

Number of Gauzes.	Rate of leak in divisions per minute.
0	44
1	32·5
2	26·5
3	19·5
4	10·5
5	6

After passing through 5 gauzes the conductivity of the air has fallen to less than $\frac{1}{7}$ of its original value. Experiments were tried with gauzes of different degrees of coarseness with the same general result. The discharging-power varies with the coarseness of the gauze, and appears to depend more on the ratio of the area of metal to the area of the openings than on the actual size of the opening. If a copper gauze has such a power of removing the carriers from the gas, we can readily see why a small plug of cotton-wool should completely abstract the ions from the gas passing through it. The rapid loss of conductivity is thus due to the smallness of the carrier and the consequent rapidity of diffusion.

§ 19. *General Remarks.*

The cause and origin of the radiation continuously emitted by uranium and its salts still remain a mystery. All the results that have been obtained point to the conclusion that uranium gives out types of radiation which, as regards their effect on gases, are similar to Röntgen rays and the secondary radiation emitted by metals when Röntgen rays fall upon them. If there is no polarization or refraction the similarity

* Townsend, Phil. Mag. June 1898.

is complete. J. J. Thomson* has suggested that the re-grouping of the constituents of the atom may give rise to electrical effects such as are produced in the ionization of a gas. Röntgen's† and Wiedemann's‡ results seem to show that in the process of ionization a radiation is emitted which has similar properties to easily absorbed Röntgen radiation. The energy spent in producing uranium radiation is probably extremely small, so that the radiation could continue for long intervals of time without much diminution of internal energy of the uranium. The effect of the temperature of the uranium on the amount of radiation given out has been tried. An arrangement similar to that described in § 11 was employed. The radiation was completely absorbed in the gas. The vessel was heated up to about 200° C.; but not much difference in the rate of discharge was observed. The results of such experiments are very difficult to interpret, as the variation of ionization with temperature is not known.

I have been unable to observe the presence of any secondary radiation produced when uranium radiation falls on a metal. Such a radiation is probably produced, but its effects are too small for measurement.

In conclusion, I desire to express my best thanks to Prof. J. J. Thomson for his kindly interest and encouragement during the course of this investigation.

Cavendish Laboratory, Sept. 1st, 1898.

IX. Notices respecting New Books.

A Treatise on Dynamics of a Particle; with numerous examples. By Dr. E. J. ROUTH, F.R.S. Cambridge: University Press. Pp. xii + 417.

THAT this work is a thorough one on its subject is a matter of course, but it is more than this, it is a most interesting one. As Dr. Routh remarks in the opening words of his preface, "so many questions which necessarily excite our interest and curiosity are discussed in the dynamics of a particle that this subject has always been a favourite one with students." He puts the question, how is it that by observing the motion of a pendulum we can tell the time of rotation of the earth, or, knowing this, can deduce the latitude of the place? Other such problems excite our curiosity at the very beginning of the subject. When we study the replies to those problems we find new objects of interest, and so we mount higher and higher until we include the planetary perturbations, and take account of the finite size of bodies. So far does Dr. Routh carry us until he approximates quite closely to his familiar Rigid Dynamics. One has hitherto associated his work and name primarily with this latter subject, but as for some forty years the whole mathematical curriculum must have occupied his thoughts, he must have many potential books in his

* Proc. Camb. Phil. Soc. vol. ix. pt. viii. p. 397 (1898).

† Wied. Ann. lxiv. (1898). ‡ Zeit. f. Electrochemie, ii. p. 159 (1895).

mind, and we trust that his present leisure will enable him to collect, into book form, the accumulated stores of these past years. Our task is a simple one. We shall merely indicate what are the subjects discussed. There are in all eight chapters. The headings are:—Elementary Considerations; Rectilinear Motion; Motion of Projectiles; Constrained Motion in Two Dimensions; Motion in Two Dimensions; Central Forces; Motion in Three Dimensions; and some Special Problems. The work closes with two notes: the first on an Ellipsoidal Swarm of Particles, and the second on Lagrange's Equations, a new form for the Lagrangian function, and a rotating field. The great value to the student appears to us to be the thorough discussion of a large number of illustrative problems. As in his previous books, Dr. Routh gives ample reference to original memoirs, a number of historical notes, and a useful Index. Our reference to the Preface sufficiently indicates the wide range included under the heading Dynamics of a Particle.

X. *Intelligence and Miscellaneous Articles.*

SUSCEPTIBILITY OF DIAMAGNETIC AND WEAKLY MAGNETIC SUBSTANCES.

To the Editors of the Philosophical Magazine.

GENTLEMEN,

IN the issue of the 'Philosophical Magazine' for December 1898, in a note referring to the article published by me in the May number 1898, "On the Susceptibility of Diamagnetic and Weakly Magnetic Substances," Professor Quincke draws attention to the fact that he had previously described* a method essentially similar to the one I used for the determination of the susceptibility and had applied it in investigating the susceptibility of Iron, Nickel, and Cobalt, among other things.

That I failed to refer to this note of Professor Quincke's, and to a communication by Lord Kelvin † on the same subject, was due to the fact that I did not learn of them until after the article referred to above had appeared.

I may be allowed to add that the method in the form used by me, involving the use of prismatic slabs *transversely* magnetized, does not admit of application to Iron, Nickel, and Cobalt, since in this case the induced magnetization would depend almost altogether upon the shape of the substance and but slightly upon its susceptibility‡. In Lord Kelvin's note upon this subject the restriction that the method may be applied to those bodies only which are diamagnetic or slightly magnetic is implied in the title.

Very truly yours,

ALBERT P. WILLS.

Berlin, Dec. 10, 1898.

* *Tageblatt der 62 Versammlung der Deutscher Naturforscher und Aerzte*, Heidelberg, 1889, p. 209.

† "On a Method of determining in Absolute Measure the Magnetic Susceptibility of Diamagnetic and *Feebly* Magnetic Solids."—Report of the British Association, 1890, p. 745.

‡ Maxwell, 'Electricity and Magnetism,' vol. ii. pp. 65, 66.

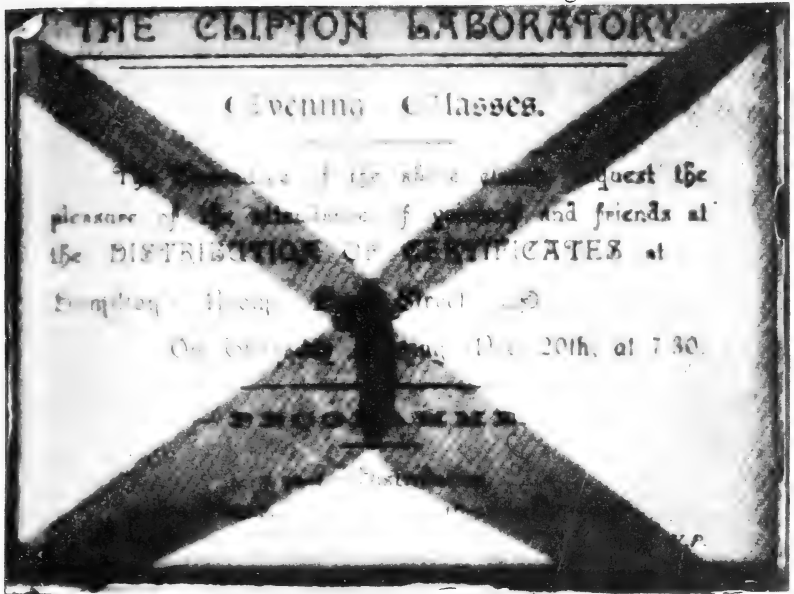

Fig. 5.



Fig. 2.

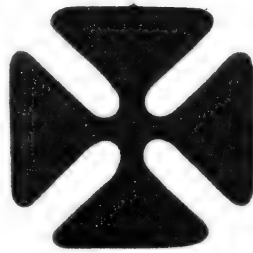

Fig. 3.



Fig. 1.

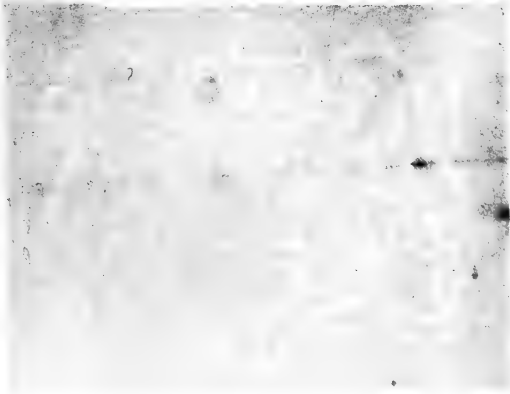
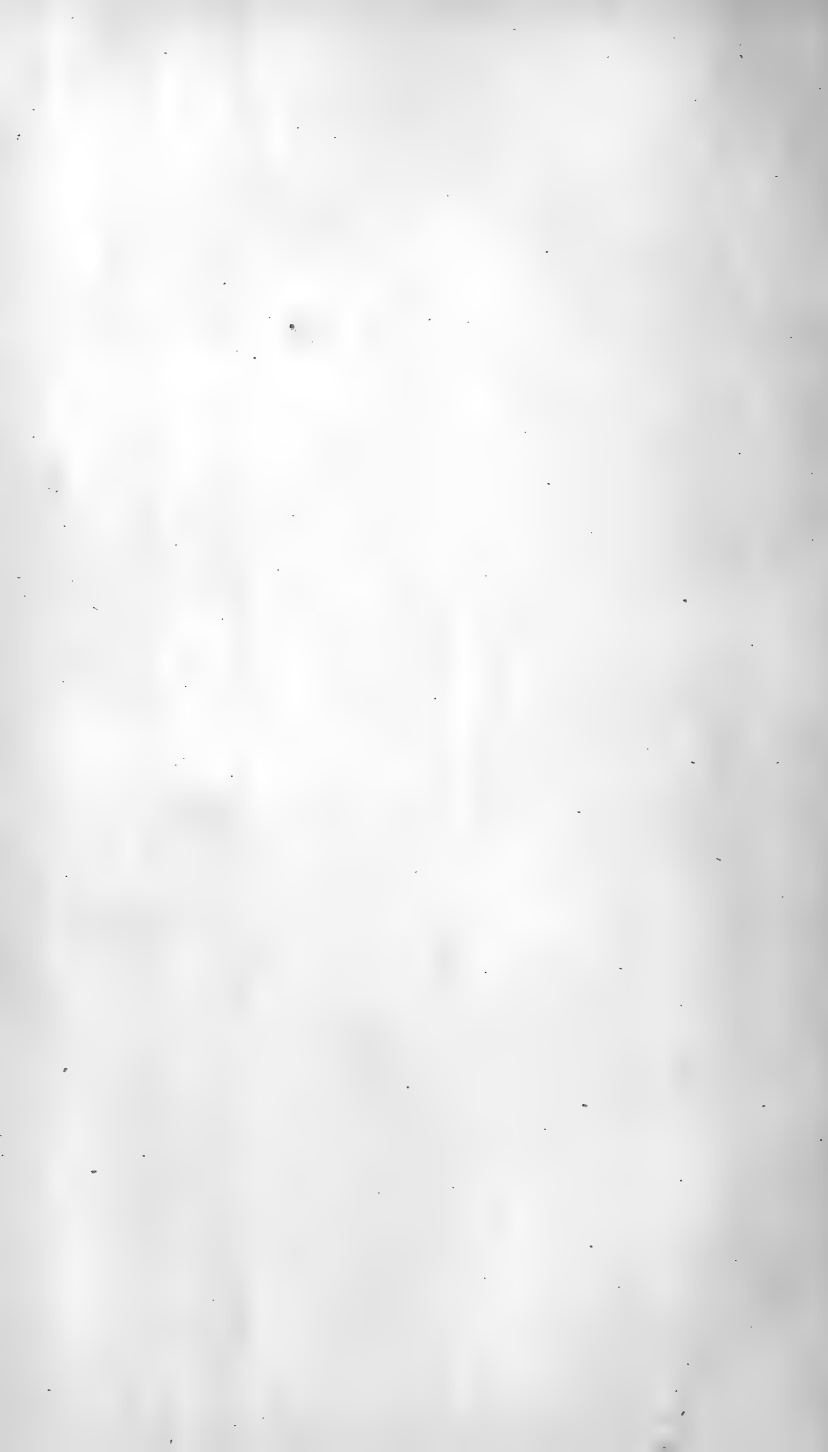
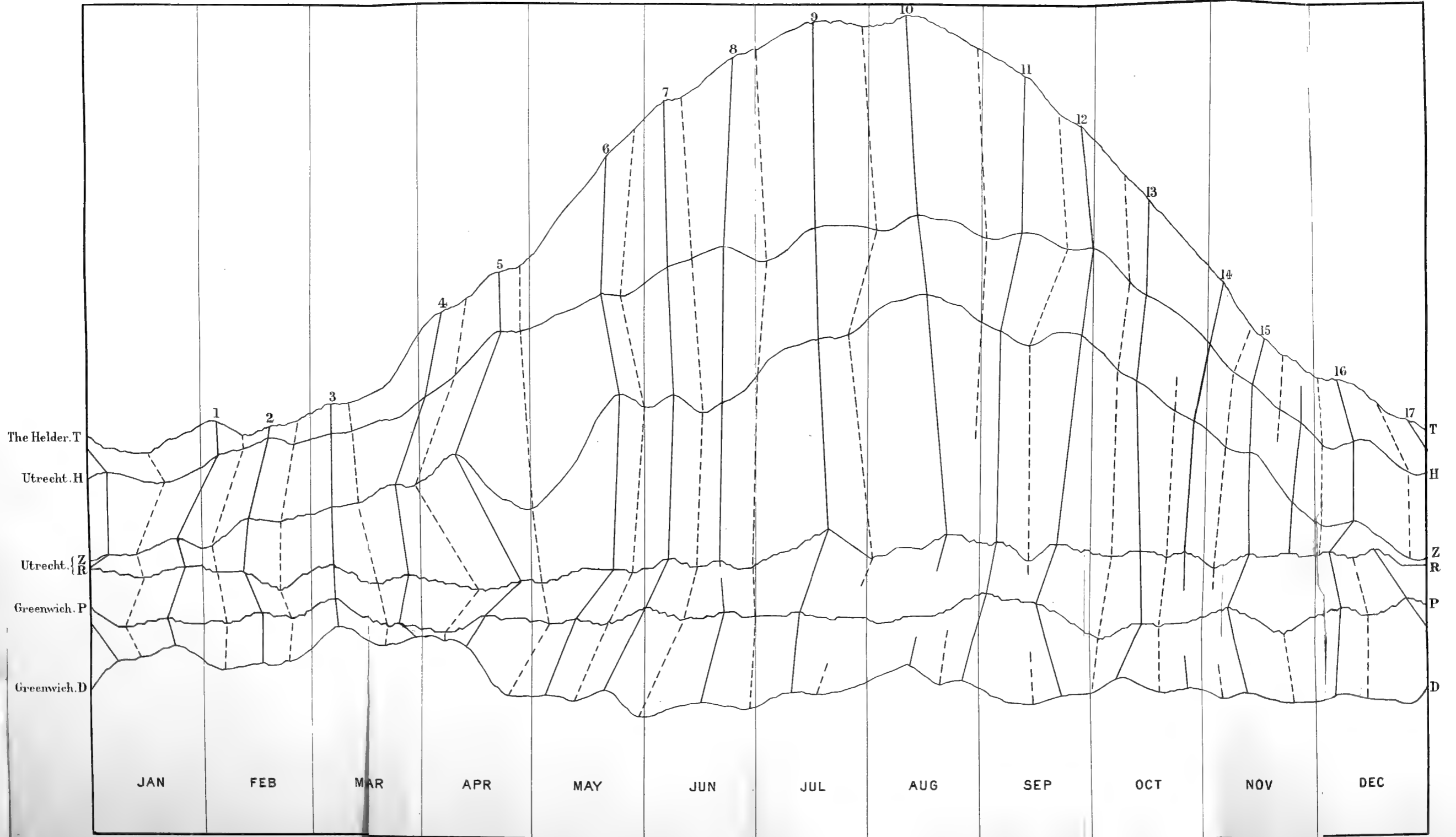

Fig. 4.



9





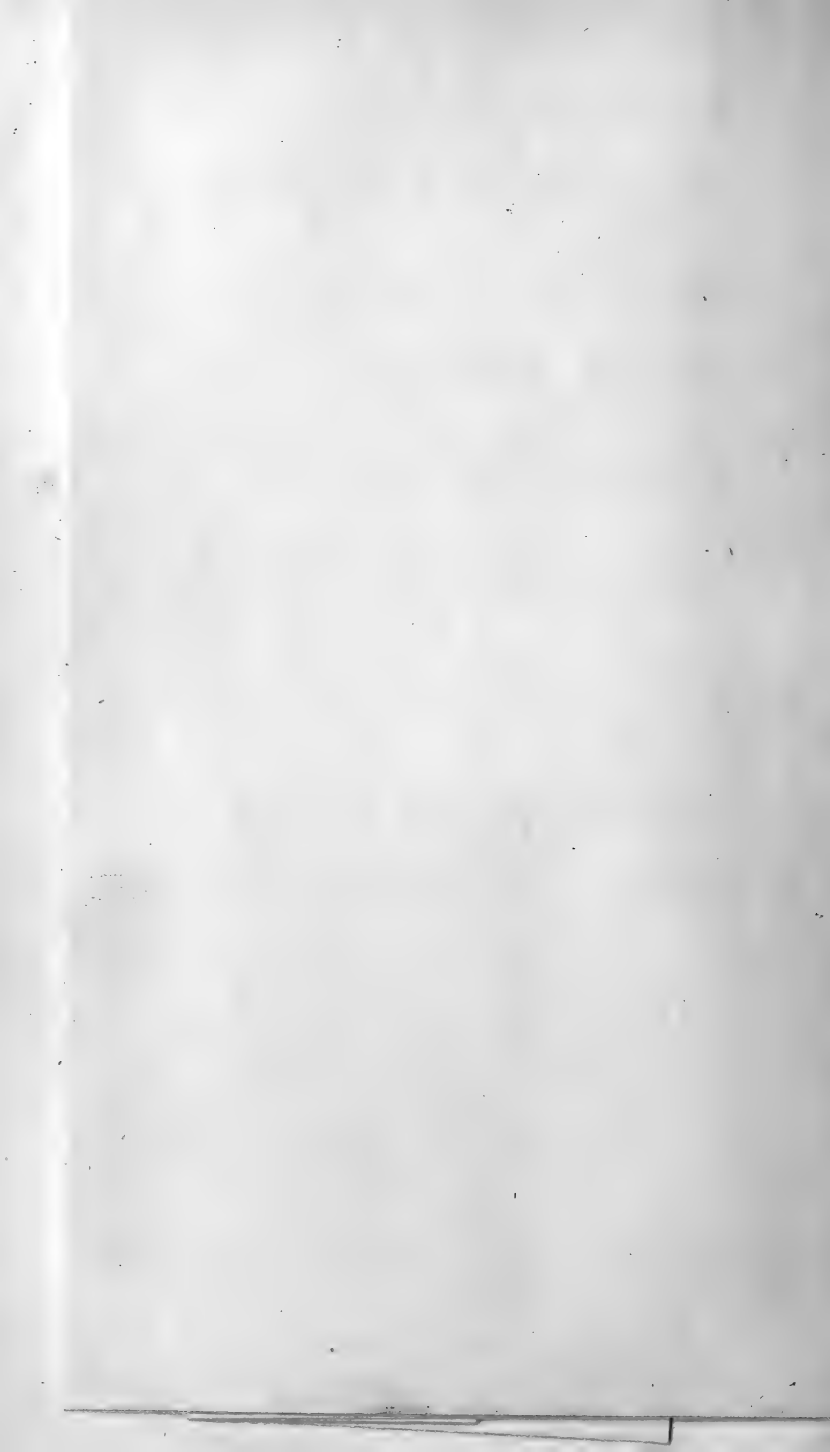

THE
LONDON, EDINBURGH, AND DUBLIN
PHILOSOPHICAL MAGAZINE
AND
JOURNAL OF SCIENCE,

[FIFTH SERIES.]

FEBRUARY 1899.

XI. *Radiation Phenomena in the Magnetic Field.*—*Magnetic Perturbations of the Spectral Lines.* By THOMAS PRESTON, M.A., D.Sc., F.R.S.*

IN the April number of this Magazine † I described a series of observations on "Radiation Phenomena in a strong Magnetic Field." Briefly stated, the results obtained showed that while the majority of spectral lines became triplets when the source of light was placed in the magnetic field and viewed across the lines of force, yet this did not hold good of all lines, for some were observed to be resolved into quartets, or sextets, or other forms by the magnetic field under precisely the same circumstances.

I pointed out at that time that these quartets &c. might be regarded as modified forms of the normal or standard triplet form, and might possibly be derived from it by reversal. Thus, if each line of a triplet be reversed (that is, if an absorption-band occurs along its middle), then we have six lines instead of three, and so on for the other forms. I also pointed out, however, that the general appearance of these modified forms did not by any means favour that explanation, for they possessed none of the ordinary characteristics of reversals. Nevertheless, this explanation could

* Communicated by the Author.

† *Phil. Mag.* vol. xlv. p. 325 (1898). The experiments described in this paper were performed in Oct. and Nov. 1897, and communicated to the Royal Dublin Society in December 1897. See *Trans. Roy. Dubl. Soc.* vol. xv. p. 385 (1898).



not be ignored till it had been proved by experiment that the modifications were actually caused by other agencies, and this I endeavoured to do by two lines of attack.

In the first place, if these phenomena are due to reversal, it is likely that they will cease to exist when the quantity of vapour in the source of light is greatly reduced. I accordingly tried sparking with weak solutions of salts instead of with metallic electrodes, but in no case did the quartets, or other modifications, reduce to the triplet form, but on the contrary they became clearer and more precise as the lines became sharper with the reduced quantity of vapour. Nevertheless this was not regarded as conclusive or even seriously in opposition to the supposition of reversal, for the appearance of reversed lines in the strong magnetic field when the spark is blown about might differ from that of an ordinary reversal.

I accordingly endeavoured to gradually increase the strength of the magnetic field and observe if the components of the supposed reversed line remained at the same distance apart or became more widely separated as the strength of the field increased. The extent to which I was able to increase the field at that time was not, however, sufficient to enable me to determine with sufficient certainty whether the reversal hypothesis was tenable or not. For although the components of the supposed reversed line appeared to separate under the increased field, yet this separation was not sufficiently great to overthrow the reversal hypothesis, for it might be said that the absorbed band along the middle of the line had merely become a little wider. The weight of evidence, however, appeared to be against the reversal theory; and in order to further test this matter I had a powerful electromagnet specially built which it was hoped would furnish a field sufficiently strong to determine matters decisively, and in this respect it has not disappointed expectation. Thanks to the courtesy of the University Authorities and of the Curator, Dr. W. E. Adeney *, I was able to resume work at the Royal University with improved apparatus, and it was soon found that the reversal theory must be abandoned and that the explanation of the various deviations from the normal triplet-types must be sought for in other agencies.

Before describing these more recent results, it will render the explanation more intelligible if we refer for a moment to figs. 1, 2, 3, 4. In fig. 1 the three lines A, B, C are

* I am deeply indebted to Dr. Adeney throughout this and the previous investigations, for he invited me to the Royal University laboratories and facilitated my work under conditions which necessarily interfered with his own researches.

supposed to represent the triplet into which a spectral line of the standard type becomes resolved by the action of the magnetic field, and fig. 2 in the same way represents a quartet produced by the magnetic field, or, if we may say so,

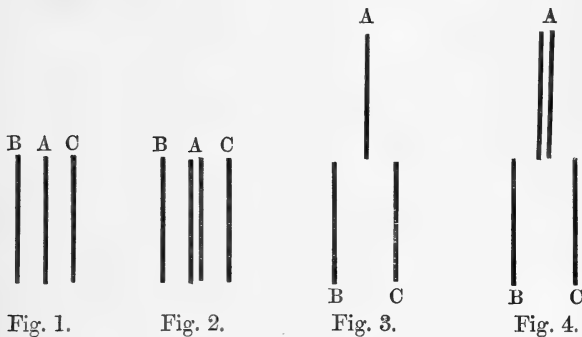

a triplet in which the middle line A has become a doublet. These lines are all plane-polarized, the vibrations in the side-lines B and C being parallel to their length, while the vibrations in the central constituents A are in the perpendicular direction, when the light is viewed across the lines of force.

Hence, if a double-image prism be placed before the slit of the spectroscope in the path of the beam of light, the two plane-polarized parts can be separated so that one part (say A) forms one image on the slit, while the other part (B and C) forms another image on the slit. These two images, being separated, give rise to two spectra in the field of view of the spectroscope which may be separated or may be caused to partially overlap if so desired. As a consequence a triplet or a quartet which appears in the field of view, as shown in figs. 1 and 2, without the double-image prism, becomes transformed by the double-image prism into figs. 3 and 4. Thus the light vibrating parallel to the lines of force (A) is separated from that vibrating in the perpendicular direction (B and C), and this facilitates observation in the case of small separations and in the case of overlapping lines. This separation of the two parts can of course be effected by a Nicol's prism, but the double-image prism has the advantage of showing the two parts simultaneously.

The question now before us is—can the quartet shown in figs. 2 and 4 be derived from the triplets figs. 1 and 3 by mere reversal of the central line A. In answer to this question, it is to be remarked that it is not the central line A alone which shows as a doublet, for in some cases the

side lines B and C show as doublets and in others as triplets; and again, in some quartets the distance between the central pair A is almost as great as, and it may be greater than, the distance between the side lines B and C. Further, as the magnetic field increases in strength, the distance between the members of the central pair A (fig. 4) increases at the same rate as the distance between the side lines B and C. Again, when the side lines B and C are each resolved into doublets (or triplets) the separation of the constituent lines of each of these doublets (or triplets) increases with the magnetic field like the separation of the components of the normal triplet A B C shown in fig. 1; and in face of these facts the reversal theory becomes quite untenable.

The general phenomenon, therefore, which remains to be explained is the further resolution of each constituent of the normal triplet into a doublet or a triplet or some other system; and, as we shall see immediately, the electromagnetic theory proposed by Dr. Larmor* may be extended to embrace all the phenomena yet observed. Before proceeding to consider this explanation, however, it is necessary to refer to a particular case which was recently announced as having been observed by MM. Becquerel and Deslandres†, and subsequently by Messrs. J. S. Ames, R. F. Earhart, and H. M. Reese ‡, and which they refer to as an example of "reversed polarization." This phenomenon is represented to be as follows.

Consider the triplet shown in fig. 1; then in the normal state of affairs the vibrations in A are parallel to the lines of force, while the vibrations in B and C are perpendicular to the lines of force. Now in the spectrum of iron the authors just named have recorded that they observed triplets in which the vibrations in the middle line were perpendicular to the lines of force, while the vibrations in the side lines were parallel to the lines of force—the reverse of the normal case. Stated in this way the phenomenon is very startling, and appears at first sight to be directly contradictory to all theoretical expectation. But if we return to fig. 4, it will be seen at once that this phenomenon, supposing it to exist, can be regarded merely as an extreme case of the quartet. For, as we have already said, the horizontally vibrating lines A of the quartet may be close together or widely separated. They may be even more widely separated than the vertically vibrating lines B and C (fig. 5), and in some particular cases

* Dr. J. Larmor, *Phil. Mag.* vol. xlv. p. 505 (1897).

† *Comptes Rendus*, t. cxxvi. p. 997, April 4th, 1898.

‡ *Astro-Physical Journal*, vol. viii. p. 48, June 1898.

B and C may be very close together, or coincide, while the centre pair A are separated by a considerable space, as shown in fig. 6. In this extreme case we are furnished with a triplet in which the centre as it were encloses the sides. But this is no specially new form, being quite continuous with the other types of modification.

Fig. 5.



Fig. 6.



Once the doubling of the centre line (A, figs. 2 or 4) is explained, the other types follow in sequence as expected variations, for the cause which converts A into a doublet may be sufficiently powerful to separate the constituents of A more widely than B is separated from C, and the separation of the constituents of A might be tolerably large, even though the separation of B and C is quite insensible. Thus, if the so-called reversed polarization is shown by any lines, the explanation offers no difficulty once we have explained the quartet, but it is doubtful if the lines indicated in the spectrum of iron by the French and American observers just mentioned show this peculiarity. Iron was one of the first substances which I examined*, because I considered it might present peculiarities, but I did not observe in it any marked differences from the behaviour of other substances. Several quartets and other slight modifications occur, but the lines referred to by the French and American observers do not, on my photographic plates, exhibit the exact peculiarity attributed to them. The central part corresponding to A in fig. 4 is a doublet without doubt, but the remainder (corresponding to the lines B and C, fig. 4) does not appear to be by any means a single line, but looks rather like a triplet of which

* See Proc. Royal Society, January 1898. The doublets referred to in this paper turned out on analysis to be quartets.

the side lines are broad and weak, while the centre is much denser. It is just possible, and indeed probable, that these modifications may be really quartets, of which the side lines B and C are broad and weak, and overlap at their inner edges, giving the appearance of a bright central line winged with two weaker bands.

The distance between the side lines B and C is about the same as that between the components of A, and when the double-image prism is not used, the lines in question photograph as triplets, *i. e.* as bands having three ribs or denser parts running along them lengthwise. With a much stronger field it could be determined whether the part BC in these lines is really a triplet or an overlapping doublet; but as they are all weak lines requiring long exposure (four hours in my case), it is not easy to arrange to have a very strong field for such a long time. However, it is a matter of very little importance at present, for if we can explain the quartet we are on the highway to the explanation of all the various modifications.

For this purpose let us revert to Dr. Larmor's paper already cited. In this investigation he considers merely the simple case of a single ion describing an elliptic orbit under a central force directly proportional to the distance. This electric charge, when subject to the influence of the magnetic field, is so acted on that its elliptic orbit is forced into precession round the direction of the magnetic force, that is, as a first approximation. For the equations of motion of the ion moving round a centre of force in a magnetic field are, as a first approximation, the same as those which obtain for a particle describing an elliptic orbit under a central force when the orbit precesses or revolves round a line through its centre drawn in the direction of the lines of magnetic force. If N be the natural frequency of revolution of the particle in its orbit and n the frequency of revolution of the orbit in its precessional movement, the combined movement is equivalent to three coexisting motions of frequencies $N+n$, N , and $N-n$ respectively. When n is small compared with N so that its square may be neglected, the equations of motion of the particle in the revolving orbit become identical with those of the moving ion in the magnetic field.

This simple theory therefore predicts that a single spectral line should be converted into a triplet by the action of the magnetic field, and that the constituents of this triplet should be plane-polarized when viewed across the lines of force. It teaches us that the cause of the tripling is the forced precession of the ionic orbits round the lines of magnetic force, and it

assigns a dynamical cause for this precession in the action of the magnetic field on the ionic charge moving through it.

But up to this point the electromagnetic solution deals with a perturbation which is really not the full equivalent of a precessional movement of the orbit, and therefore the investigation given by Dr. Larmor applies, as he himself states, to a single simple case. For the equations of motion of a particle describing under a central force an elliptic orbit which precesses with angular velocity ω round a line whose direction-cosines are (l, m, n) are

$$\ddot{x} = -\Omega^2 x + 2\omega(n\dot{y} - m\dot{z}) + \omega^2 x - \omega^2 l(lx + my + nz), \quad . \quad (1)$$

with two similar equations for \dot{y} and \dot{z} , whereas the equations of motion of the ionic charge moving under a central force in a magnetic field are, as given by Dr. Larmor,

$$\ddot{x} = -\Omega^2 x + k(n\dot{y} - m\dot{z}), \quad . \quad . \quad . \quad (2)$$

with two similar expressions for \dot{y} and \dot{z} . The latter equation coincides with the former if we neglect ω^2 and take $2\omega = k$, that is, when the precessional motion is relatively small.

The motion imposed on the ion by the electromagnetic theory is therefore merely a simple type of precessional perturbation of the orbit, and, as other perturbations may occur, and indeed ought to be expected to occur, it is clear that the simple triplet is not the only form which we should expect to meet with when the matter is investigated experimentally. Thus, if the orbit besides having a precessional motion has in addition an apsidal motion, that is a motion of revolution in its own plane, then each member of the triplet arising from precession will be doubled, and we are presented with a sextet as in the case of the D_2 line of sodium. Similarly, if the inclination of the plane of the orbit to the line round which precession takes place be subject to periodic variations, then each member of the precessional triplet will itself become a triplet, and so on for other types of perturbation.

It is quite unnecessary to enter into these matters in any detail here, for the whole explanation was fully given and published in 1891 by Dr. G. J. Stoney*, that is, six years before the effects requiring explanation had been observed.

Dr. Stoney's aim was to explain the occurrence of doublets and equidistant satellites in the spectra of gases, that is in the normal spectra unaffected by the magnetic field—for at

* This most important paper of Dr. Stoney's was published in the Scientific Transactions of the Royal Dublin Society, vol. iv. p. 563 (1891), "On the Cause of Double Lines and of Equidistant Satellites in the Spectra of Gases."

that time the influence of the magnetic field was not known to exist. The character of certain spectra indicated that the lines resolved themselves naturally into groups, or series. For example, in the monad elements Na, K, &c. the spectrum resolves itself into three series of doublets like the D doublet in sodium, and Dr. Stoney's object was to explain the existence of these pairs of lines. For this purpose he considered what the effect would be on the period of the radiations from a moving electron if subject to disturbing forces. In the first place he determined that if the disturbing forces cause the orbit to revolve in its own plane, that is, cause an apsidal motion, then each spectral line will become a doublet. The frequencies of the new lines will be $N + n$ and $N - n$, where N is the frequency of the original line and n the frequency of the apsidal revolution. This is very easily deduced by Dr. Stoney from the expressions for the coordinates of the moving point at any time t . Thus if a particle describes an ellipse under a force directed towards its centre (law of direct distance), its coordinates at any instant are

$$x = a \cos \Omega t, \quad y = b \sin \Omega t,$$

in which Ω is equal to $2\pi N$, where N is the frequency of revolution. But if, in addition, the ellipse revolves around its centre in its own plane with an angular velocity ω , it is easily seen by projection that the coordinates at any time are

$$\begin{aligned} x &= a \cos \Omega t \cos \omega t - b \sin \Omega t \sin \omega t, \\ y &= a \cos \Omega t \sin \omega t + b \sin \Omega t \cos \omega t, \end{aligned}$$

and these are equivalent to

$$\begin{aligned} x &= \frac{1}{2}(a + b) \cos (\Omega + \omega)t + \frac{1}{2}(a - b) \cos (\Omega - \omega)t, \\ y &= \frac{1}{2}(a + b) \sin (\Omega + \omega)t - \frac{1}{2}(a - b) \sin (\Omega - \omega)t, \end{aligned}$$

and these in turn are equivalent to the two opposite circular vibrations

$$\left. \begin{aligned} x_1 &= \frac{1}{2}(a + b) \cos (\Omega + \omega)t \\ y_1 &= \frac{1}{2}(a + b) \sin (\Omega + \omega)t \end{aligned} \right\} \left. \begin{aligned} x_2 &= \frac{1}{2}(a - b) \cos (\Omega - \omega)t \\ y_2 &= -\frac{1}{2}(a - b) \sin (\Omega - \omega)t \end{aligned} \right\}.$$

The resultant motion is consequently equivalent to two circular motions in opposite senses of frequencies $N + n$ and $N - n$.

This is an analysis of the motion without any regard to the dynamical origin of it; but if we treat it from a dynamical point of view, the equations of motion will exhibit the forces which are necessary to bring about the supposed motion. Thus, if the orbit rotates with angular velocity ω in its own

plane while the particle is attracted to a fixed centre with a force $\Omega^2 r$, then, by taking the moving axes of the orbit as axes of reference, the equations of motion are

$$\left. \begin{aligned} \ddot{x} &= -\Omega^2 x + \omega^2 x + 2\omega \dot{y}, \\ \ddot{y} &= -\Omega^2 y + \omega^2 y - 2\omega \dot{x}, \end{aligned} \right\} \dots \dots \dots (3)$$

so that if $(x, y) = e^{ipt}$ be a solution, we have at once

$$p = \Omega \pm \omega,$$

which shows the doubly periodic character of the motion, and also exhibits the character of the perturbing forces necessary to produce the given apsidal motion of the orbit. For if the orbit were fixed, the equations of motion would be $(\ddot{x}, \ddot{y}) = -\Omega^2(x, y)$: hence the remaining terms on the right-hand side of the above equations must represent the perturbing forces. Of these the final terms $2\omega \dot{y}$ and $-2\omega \dot{x}$ are the x and y components of a force $2\omega v$, where v is the velocity of the particle, acting in a direction perpendicular to v , that is along the normal to the path of the particle, and represent the forces which a charged ion would experience in moving through a magnetic field with the lines of force at right angles to the plane of the orbit, if 2ω be taken equal to k in Dr. Larmor's equations (2). The other pair of terms, $\omega^2 x$ and $\omega^2 y$, represent a centrifugal force arising from the imposed rotation ω . If we neglect ω^2 , the above equations become identical with those which hold in Larmor's theory for the moving ion, as they obviously should, for an apsidal motion in the plane of the orbit is the same thing as a precession about a line perpendicular to the plane of the orbit, and in this case there will be no component in the direction of the axis round which precession takes place; accordingly the middle line of the precession triplet will be absent, and we are furnished merely with a doublet.

Now in the magnetic field the perturbing force, being the magnetic force, is fixed in direction, and on this account the doublets and triplets arising from perturbations caused by it are polarized. On the other hand, if the perturbing forces be not constant in direction, this polarization should cease to exist, and polarization should not be expected in the case of any lines of the normal spectrum, even though these happen to be derived from other lines by perturbations in the manner conceived by Dr. Stoney.

In the same way the general case of precessional motion may be worked backwards in order to discover the types of force which produce the perturbation. Thus, taking the axes

moving with angular velocity ω round a line whose direction-cosines are l, m, n , the equations of motion

$$\left. \begin{aligned} \ddot{x} &= -\Omega^2 x + 2\omega(n\dot{y} - m\dot{z}) + \omega^2 x - \omega^2 l(lx + my + nz), \\ \ddot{y} &= -\Omega^2 y + 2\omega(l\dot{z} - n\dot{x}) + \omega^2 y - \omega^2 m(lx + my + nz), \\ \ddot{z} &= -\Omega^2 z + 2\omega(m\dot{x} - l\dot{y}) + \omega^2 z - \omega^2 n(lx + my + nz) \end{aligned} \right\} \quad (4)$$

show that the perturbing forces consist firstly of a force $2\omega v \sin \theta$; where v is the velocity of the particle and θ the angle which its direction makes with the axis round which the precession ω takes place. This force acts along the normal to the plane of v and ω (the direction of the velocity and the axis of rotation), and is precisely the force experienced by an ion moving in a magnetic field in Larmor's theory. The remaining terms containing ω^2 are the components of a centrifugal force arising from the rotation round the axis (l, m, n) , and this is negligible only when ω is relatively small.

If the direction l, m, n be taken to be that of the lines of magnetic force, and if the axis of z be taken to coincide with this direction, then the equations (4) simplify into

$$\left. \begin{aligned} \ddot{x} &= -(\Omega^2 - \omega^2)x + 2\omega\dot{y} \\ \ddot{y} &= -(\Omega^2 - \omega^2)y - 2\omega\dot{x} \\ \ddot{z} &= -\Omega^2 z \end{aligned} \right\} \quad \dots \dots \dots (5)$$

and these are the equations of motion of a particle describing an elliptic orbit which precesses with angular velocity ω round the axis of z . The two first of these equations contain x and y and give the projection of the orbit on the plane x, y , at right angles to the axis of the magnetic field. This projection is an ellipse revolving in its own plane with an apsidal angular velocity ω , and gives rise to the two side lines of the normal triplet of frequencies $(\Omega \pm \omega)/2\pi$. On the other hand, the vibration parallel to the axis of z is unaffected by the precessional motion and gives rise to the central line of the triplet of frequency $\Omega/2\pi$.

Now in order to account for the quartet (fig. 2) we must introduce some action which will double the central line A while the side lines B and C are left undisturbed. That is, we must introduce a double period into the last of equations (5) while the first and second remain unchanged. This is easily done if we write the equation for z in the form

$$z = A \sin \Omega t \dots \dots \dots (6)$$

and remark that this will represent two superposed vibrations of different periods, if we regard A as a periodic function of the time instead of a constant. That is, if we take A to be of the form $a \sin nt$, we shall have

$$z = a \sin nt \sin \Omega t = \frac{a}{2} [\cos (\Omega - n)t - \cos (\Omega + n)t],$$

which represents two vibrations of equal amplitude and of frequencies $(\Omega - n)/2\pi$ and $(\Omega + n)/2\pi$ as required to produce the quartet. The magnitude of n determines whether the separation of the constituents of the central line A (fig. 2) shall be less than, or greater than, the separation of the side lines B and C , and if the former is sensible while the latter is insensible we are presented with the case depicted in fig. 6—although, as I have said before, my observations do not confirm the existence of this case.

The supposition made above to account for the doubling of the middle line, viz. that the amplitude of the z component of the vibration varies periodically, is one which appears to be justified when we consider the nature of the moving system and the forces which control it. For the revolving ion is part of some more or less complex system which must set in some definite way under the action of the magnetic field—say with its axis along the direction of the magnetic force—and, in coming into this position, the inertia of the system will cause it to vibrate with small oscillations about that position of equilibrium, and this vibration superposed on the precessional motion of the ionic orbit gives the motion postulated above to explain the quartet.

This, indeed, comes to the same thing as a suggestion made by Professor G. F. FitzGerald about a year ago—shortly after I discovered the existence of the quartet form (Oct. 1897). In Professor FitzGerald's view, the ion revolving in its orbit is equivalent to an electric current round the orbit, and therefore the revolving ion and the matter with which it is associated behave as a little magnet having its axis perpendicular to the plane of the orbit. The action of the magnetic field will be to set the axis of this magnet along the lines of force, and in taking up this set the ionic orbit will vibrate about its position of equilibrium just as an ordinary magnet vibrates about its position of rest under the earth's magnetic force.

In a similar way a periodic change in the ellipticity of the orbit produces a doubling of the lines, while a periodic oscillation in the apsidal motion renders the line nebulous or diffuse; and by treating these cases in the foregoing manner the corresponding forces may be discovered. It is clear,

therefore, that perturbations of this kind are sufficient to account for all the observed phenomena, and, further, that perturbations of this kind are almost certain to be in operation throughout some, at least, of the ionic motions.

The existence of all these variations of the normal triplet type are therefore of great interest, not only in showing that the perfect uniformity required for the production of the normal triplet is not maintained, as we should expect, in all cases, but also as an experimental demonstration that the causes supposed by Dr. Stoney, in 1891, to be operative in producing doublets and satellites in the natural spectra of gases may be really the true causes by which they are produced.

Nevertheless Dr. Stoney's explanation of the natural doublets is opposed by a serious difficulty in the fact that the two lines of a given doublet, say the two D lines of sodium, behave in different ways, as if they arose from different sources rather than from the perturbation of the same source. For, in addition to the differences previously known to exist, there is the difference of behaviour in the magnetic field. Thus D_1 is a wide-middled quartet in which the distance between the central lines A (fig. 4) is nearly as great as the distance between the side lines B and C, while D_2 shows as a sextet of uniformly spaced lines.

In a similar manner individual members of the natural triplets which occur in the natural spectra of the zinc, cadmium, magnesium, &c. group behave differently. Thus if we denote the members of one of the natural triplets by the symbols T_1 , T_2 , T_3 , in ascending order of refrangibility (for example the triplet 5086, 4800, 4678 of cadmium, or the triplet 4811, 4722, 4680 of zinc, or the green *b* triplet of magnesium), we find that T_3 in all cases, in the magnetic field, shows as a pure triplet, or suffers according to the foregoing merely precessional perturbation. On the other hand, T_2 shows in each case as a quartet while T_1 is a diffuse triplet in which each of the members may prove to be complex on further resolution. This would seem to point to an essential difference in the characters of the lines T_1 , T_2 , T_3 , as if they sprang from different origins rather than immediately from the same. It is also of great interest to note that, so far as my observations yet show, these natural triplets behave differently according as they belong to Kayser and Runge's first subsidiary series or to the second subsidiary series. Thus if the triplet T_1 , T_2 , T_3 , belongs to the first subsidiary series, then the magnetic effect *decreases* from T_1 to T_3 , while if it belongs to the second subsidiary series, the magnetic effect *increases* from T_1 to T_3 . Examples of this

latter class are shown in my communication to this Journal (April 1898, p. 335), where the *increasing* character of the magnetic effect is well exhibited in the natural triplets 5086, 4800, 4678 of cadmium, and 4811, 4722, 4680 of zinc. Further examples of this, and other peculiarities, I hope to give in the near future as soon as I have fully examined and verified them.

General Law.

The first general survey of the magnetic effect on the spectral lines of any given substance did not appear to favour the view that the phenomena are subject to any simple law. According to the electromagnetic theory the separation, $\delta\lambda$, of the side lines of a magnetic triplet should, under the same conditions, vary directly as λ^2 as we pass from line to line of the same spectrum. The possibility of such a law as this seemed to be refuted by the fact that some lines are largely affected in the magnetic field while others, of nearly the same wave-length in the same spectrum, are not appreciably affected under the same circumstances. In this connexion, however, I pointed out* that "it is possible that the lines of any one substance may be thrown into groups for each of which $\delta\lambda$ varies as λ^2 , and each of these groups might be produced by the motion of a single ion. The number of such groups in a given spectrum would then determine the number of different kinds of ions in the atom or molecule.

"Homologous relations may also exist between the groups of different spectra, but all this remains for complete investigation."

Although the investigation referred to in the foregoing is still far from complete, yet the measurements so far made uniformly tend to confirm the above speculation. For the corresponding lines of the natural groups into which a given spectrum resolves itself possess the same value of e/m or $\delta\lambda/\lambda^2$, and, further, this value is the same for corresponding lines in homologous spectra of different substances.

To illustrate the meaning of this, take the case of magnesium, cadmium, and zinc, which are substances possessing homologous spectra and belonging to the same chemical group (Mendelejeff's second group). The spectra of these metals consist of series of natural triplets. The first triplet of the series in magnesium is the green *b* group consisting of the wave-lengths 5183·8, 5172·8, 5167·5; while the first cadmium triplet consists of the lines 5086, 4800, 4678, and

* Phil. Mag., April 1898, p. 337.

the first zinc triplet consists of the lines 4810·7, 4722, 4680. Each of these triplets belongs to Kayser and Runge's second *Nebenserie*, being the first terms, corresponding to $n=3$, in their formula. We should consequently expect these groups to behave similarly in the magnetic field and to show effects which are similar for corresponding lines. That this expectation is realized is shown by the following table:—

Magnesium.	Cadmium.	Zinc.	m/e or $\lambda^2/\delta\lambda$.	Character.
5183·8	5086	4810·7	18 approx.	Diffuse triplets.
5172·8	4800	4722	11·5 „	Quartets.
5167·5	4678	4680	10 „	Pure triplets.

Thus the corresponding lines 5183·8, 5086, and 4810·7 of the different substances possess the same value for m/e , while the other corresponding lines also possess a common value for the quantity m/e . The value of this quantity changes from one set of lines to another, showing, as we should expect, that the different sets arise from differences in the source which produces them.

Not only is the quantity m/e the same for corresponding lines in homologous spectra, but, as shown in the above table, the *character* of the magnetic effect is also the same for corresponding lines. Thus, while the lines along the lowest row, 5167·5, 4678, 4680, are all of the pure triplet type, the lines of the middle row all become resolved into similar quartets in the magnetic field, and the lines forming the top row are all somewhat diffuse and show as “soft” triplets of which the constituents may be really complex on further resolution.

It thus appears that the observation of radiation phenomena in the magnetic field is likely to afford a valuable means of inquiry into the so far hidden nature of the events which bring about the radiation from a luminous body, and also to give us, perhaps, some clearer insight into the structure of matter itself.

XII. *On the Reflexion and Refraction of Solitary Plane Waves at a Plane Interface between two Isotropic Elastic Mediums—Fluid, Solid, or Ether.* By Lord KELVIN, G.C.V.O.*

§ 1. “ELASTIC SOLID” includes fluid and ether; except conceivable dynamics† of the mutual action across the interface of the two mediums. Maxwell’s electromagnetic equations for a homogeneous non-conductor of electricity are identical with the equations of motion of an incompressible elastic solid ‡, or with the equations expressing the rotational components of the motion of an elastic solid compressible or incompressible; but not so their application to a heterogeneous non-conductor or to the interface between two homogeneous non-conductors §.

§ 2. The equations of equilibrium of a homogeneous elastic solid, under the influence of forces X, Y, Z, per unit volume, acting at any point (x, y, z) of the substance are given in Stokes’ classical paper “On the Theories of the Internal Friction of Fluids in Motion, and of the Equilibrium and Motion of Elastic Solids,” p. 115, vol. i. of his ‘Mathematical Papers’; also in Thomson and Tait’s ‘Natural Philosophy’ [§ 698 (5) (6)]. Substituting according to D’Alembert’s principle, $-\rho\ddot{\xi}$, $-\rho\ddot{\eta}$, $-\rho\ddot{\zeta}$ for X, Y, Z, and using as in a paper of mine || of date Nov. 28, 1846, ∇^2 to denote the Laplacian operator $\frac{d^2}{dx^2} + \frac{d^2}{dy^2} + \frac{d^2}{dz^2}$, we find as the equations of motion

$$\left. \begin{aligned} \rho \frac{d^2 \xi}{dt^2} &= (k + \frac{1}{3}n) \frac{d\delta}{dx} + n \nabla^2 \xi, \\ \rho \frac{d^2 \eta}{dt^2} &= (k + \frac{1}{3}n) \frac{d\delta}{dy} + n \nabla^2 \eta, \\ \rho \frac{d^2 \zeta}{dt^2} &= (k + \frac{1}{3}n) \frac{d\delta}{dz} + n \nabla^2 \zeta, \end{aligned} \right\} \dots \dots (1),$$

* Communicated by the Author; having been read before the Royal Society of Edinburgh on December 19, 1898.

† See Math. and Phys. Papers, vol. iii. art. xcix. (first published May 1890), §§ 14-20, 21-28; and particularly §§ 44-47. Also Art. c. of same volume; from *Comptes Rendus* for Sept. 16, 1889, and Proc. Roy. Soc. Edinb., March 1890.

‡ See ‘Electricity and Magnetism,’ last four lines of § 616, last four lines of § 783, and equations (9) of § 784.

§ *Ibid.* § 611, equations (1*). In these put C=0, and take in connexion with them equations (2) and (4) of § 616. Consider K and μ as different functions of x, y, z; consider particularly uniform values for each of these quantities on one side of an interface, and different uniform values on the other side of an interface between two different non-conductors, each homogeneous.

|| Camb. and Dublin Math. Journal, vol. ii. (1847). Republished as Art. xxvii., vol. i. of Math. and Phys. Papers.

ρ denoting the density of the medium, ξ, η, ζ its displacement from the position of equilibrium (x, y, z) , and δ the dilatation of bulk at (x, y, z) as expressed by the equation

$$\delta = \frac{d\xi}{dx} + \frac{d\eta}{dy} + \frac{d\zeta}{dz} \quad \dots \quad (2).$$

§ 3. Taking $d/dx, d/dy, d/dz$ of (1), we find

$$\rho \frac{d^2\delta}{dt^2} = (k + \frac{4}{3}n)\nabla^2\delta \quad \dots \quad (3).$$

From this we find

$$\nabla^{-2}\delta = \frac{k + \frac{4}{3}n}{\rho} \cdot \left(\frac{d}{dt}\right)^{-2}\delta \quad \dots \quad (4).$$

Put now

$$\xi = \xi_1 + \frac{d}{dx}\nabla^{-2}\delta; \quad \eta = \eta_1 + \frac{d}{dy}\nabla^{-2}\delta; \quad \zeta = \zeta_1 + \frac{d}{dz}\nabla^{-2}\delta; \quad (5).$$

These give

$$\frac{\delta\xi_1}{dx} + \frac{d\eta_1}{dy} + \frac{d\zeta_1}{dz} = 0 \quad \dots \quad (6),$$

and therefore, eliminating by them ξ, η, ζ from (1), we find by aid of (4),

$$\rho \frac{d^2\xi_1}{dt^2} = n\nabla^2\xi_1; \quad \rho \frac{d^2\eta_1}{dt^2} = n\nabla^2\eta_1; \quad \rho \frac{d^2\zeta_1}{dt^2} = n\nabla^2\zeta_1; \quad (7).$$

§ 4. By Poisson's theorem in the elementary mathematics of force varying inversely as the square of the distance, we have

$$\nabla^{-2}\delta = -\frac{1}{4\pi} \iiint d(\text{volume}) \cdot \frac{\delta'}{PP'}; \quad (8),$$

where δ, δ' denote the dilatations at any two points P and P'; $d(\text{volume})$ denotes an infinitesimal element of volume around the point P'; and PP' denotes the distance between the points P and P'. This theorem gives explicitly and determinately the value of $\nabla^{-2}\delta$ for every point of space when δ is known (or has any arbitrarily given value) for every point of space.

§ 5. If now we put

$$\xi_2 = \frac{d}{dx}\nabla^{-2}\delta; \quad \eta_2 = \frac{d}{dy}\nabla^{-2}\delta; \quad \zeta_2 = \frac{d}{dz}\nabla^{-2}\delta; \quad (9),$$

we see by (5) that *the complete solution of (1) is the sum of two solutions, (ξ_1, η_1, ζ_1) satisfying (6) and therefore purely distortional without condensation; and (ξ_2, η_2, ζ_2) , which, in*

virtue of (9), is irrotational and involves essentially rarefaction or condensation or both. This most important and interesting theorem is, I believe, originally due to Stokes. It certainly was given for the first time explicitly and clearly in §§ 5-8 of his "Dynamical Theory of Diffraction"*.

§ 6. The complete solution of (3) for plane waves travelling in either or both directions with fronts specified by (α, β, γ) , the direction-cosines of the normal, is, with ψ and χ to denote arbitrary functions,

$$\delta = \psi\left(t - \frac{\alpha x + \beta y + \gamma z}{v}\right) + \chi\left(t + \frac{\alpha x + \beta y + \gamma z}{v}\right) \quad (10),$$

where

$$v = \sqrt{\frac{k + \frac{4}{3}n}{\rho}} \dots \dots \dots (11);$$

so that v denotes the propagational-velocity of the condensational-rarefactional waves. By inspection without the aid of (8), we see that for this solution

$$\nabla^{-2}\delta = v^2\left(\frac{d}{dt}\right)^{-2} \left[\psi\left(t - \frac{\alpha x + \beta y + \gamma z}{v}\right) + \chi\left(t + \frac{\alpha x + \beta y + \gamma z}{v}\right) \right] \quad (12).$$

For our present purpose we shall consider only waves travelling in one direction, and therefore take $\chi=0$; and, for convenience in what follows, we shall take $-\left(\frac{d}{dt}\right)^{-1}f$ instead of $v\left(\frac{d}{dt}\right)^{-2}\psi$; f being an arbitrary function. Thus by (12) and (9) we have, for our condensational-rarefactional solution,

$$\frac{\xi_2}{\alpha} = \frac{\eta_2}{\beta} = \frac{\zeta_2}{\gamma} = f\left(t - \frac{\alpha x + \beta y + \gamma z}{v}\right). \quad \dots \quad (13).$$

In the wave-system thus expressed the motion of each particle of the medium is perpendicular to the wave-front (α, β, γ) . For purely distortional motion, and wave-front still (α, β, γ) and therefore motion of the medium everywhere perpendicular to (α, β, γ) , or *in the wave-front*, we find similarly from (7) and (6)

$$\frac{\xi_1}{\alpha A} = \frac{\eta_1}{\beta B} = \frac{\zeta_1}{\gamma C} = f\left(t - \frac{\alpha x + \beta y + \gamma z}{u}\right) \dots \dots (14),$$

where

$$u = \sqrt{\frac{n}{\rho}} \dots \dots \dots (15),$$

* Camb. Phil. Trans., Nov. 26, 1849. Republished in vol. ii. of his 'Mathematical Papers.'

and so denotes the propagational velocity of the distortional waves ; and A, B, C are arbitrary constants subject to the relation

$$\alpha A + \beta B + \gamma C = 0 \quad . \quad . \quad . \quad (16).$$

§ 7. To suit the case of solitary waves we shall suppose the arbitrary function $f(t)$ to have any arbitrarily given value for all values of t from 0 to τ , and to be zero for all negative values of t and all positive values greater than τ . Thus τ is what we may call the transit-time of the wave, that is, the time it takes to pass any fixed plane parallel to its front ; or the time during which any point of the medium is moved by it. The thicknesses, or, as we shall sometimes say, the wavelengths, of the two kinds of waves are $u\tau$ and $v\tau$ respectively, being for the same transit-times directly as the propagational velocities.

§ 8. And now for our problem of reflexion and refraction. At present we need not occupy ourselves with the case of purely distortional waves with vibratory motions perpendicular to the plane of the incident, reflected, and refracted rays. It was fully solved by Green* with an arbitrary function to express the character of the motion (including therefore the case of a solitary wave or of an infinite procession of simple harmonic waves). He showed that it gave precisely the "sine law" which Fresnel had found for the reflexion and refraction of waves "polarized in the plane of incidence." The same law has been found for light, regarded as electromagnetic waves of one of the two orthogonal polarizations, by von Helmholtz, H. A. Lorenz, J. J. Thomson, FitzGerald, and Rayleigh†. None of them has quite dared to say that the physical action represented by his formulas for this case is a to-and-fro motion of the ether perpendicular to the plane of incidence, reflexion, and refraction ; nor has any one, so far as I know, absolutely determined whether it is the lines of electric force or of magnetic force that are perpendicular to that plane in the case of light polarized by reflexion at the surface of a transparent medium. For the action, whatever its physical character may be, which takes place perpendicular to that plane, they all seem to prefer "electric displacement," of which the only conceivable meaning is motion of electricity to and fro perpendicular to the plane. If they had declared, or even suggested, definitely this motion of ether, they would

* "On the Reflexion and Refraction of Light at the common Surface of two Non-Crystallized Media," Math. Papers, p. 258. Also Trans. Camb. Phil. Soc. 1838.

† See Glazebrook's Report "on Optical Theories" to British Association, 1885.

have been perfectly in harmony with the undulatory theory of light as we have it from Young and Fresnel. We shall return to this very simple problem of reflexion and refraction of purely distortional waves in which the motion is perpendicular to the plane of the three rays, in order to interpret in the very simplest case the meaning, for a solitary wave, of the "change of phase" discovered by Fresnel and investigated dynamically by Green for a procession of periodic waves of simple harmonic motion experiencing "total internal reflexion." (See § 20 below.)

§ 9. Meantime we take up the problem of the four reflected and refracted waves produced by a single incident wave of purely distortional character, in which the motion is in a plane perpendicular to the five wave-fronts. Taking this for XOY, the plane of our diagram, let YOZ be the interface between the two mediums. We shall first consider one single incident wave, I, of the purely distortional character. By incidence on the interface it will generally introduce reflected and refracted waves I', I_r, of its own kind, that is purely distortional, and J', J_r, reflected and refracted waves

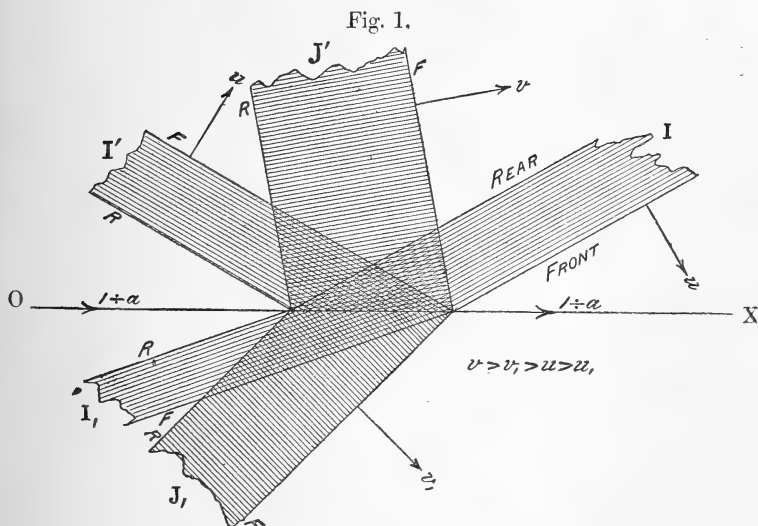

of the condensational-rarefactional kind. The diagrams represent, for two cases, sections of portions of the five waves by the plane XOY. F and R show the front and rear of each wave; and the lines of shading belonging to it show the direction of the motion, or of the component, which it

gives to the medium. The inclinations of the fronts and rears to OX, being what are ordinarily called the angle of incidence

Fig. 2.

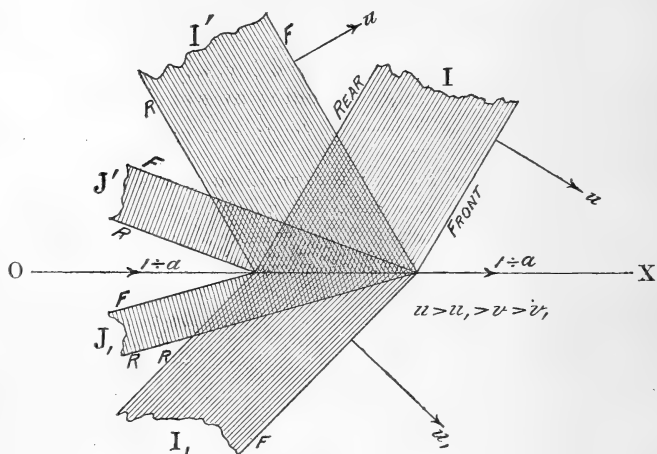

and the angles of reflexion or refraction of the several waves, will be denoted by i, i', i_1, j, j_1 . The value of γ for each of the five waves is zero, and the values of α and β are as shown in the following table :-

	α .	β .
I.....	$+\sin i$	$-\cos i$
I'.....	$+\sin i$	$+\cos i$
I ₁	$+\sin i_1$	$-\cos i_1$
J'.....	$+\sin j$	$+\cos j$
J ₁	$+\sin j_1$	$-\cos j_1$

The section of the five waves by OX is the same for all, being expressed by $u\tau/\sin i$ for I, and by corresponding formulas for the four others. Hence if we denote τ -times its

reciprocal by a , we have

$$a = \frac{\sin i}{u} = \frac{\sin i_1}{u_1} = \frac{\sin j}{v} = \frac{\sin j_1}{v_1} \dots \quad (17),$$

where u and u_1 are the propagational velocities of the distortional waves, and v, v_1 , those of the condensational waves in the two mediums. If now we take

$$\begin{aligned} b &= a \cot i = \sqrt{(u^{-2} - a^2)}; & b_1 &= a \cot i_1 = \sqrt{(u_1^{-2} - a^2)}; \\ c &= a \cot j = \sqrt{(v^{-2} - a^2)}; & c_1 &= a \cot j_1 = \sqrt{(v_1^{-2} - a^2)}; \end{aligned} \quad (18),$$

we have for the arguments of f in the five waves

$$t - ax + by; \quad t - ax - by; \quad t - ax + b_1y; \quad t - ax - c_1y; \quad t - ax + c_1y \quad (19).$$

§ 10. Following Green* in calling the two sides of the interface the upper and lower medium respectively (and so shown in the diagram), we have for the components of the displacement in the upper medium

$$\left. \begin{aligned} \xi &= bI f(t - ax + by) - bI' f(t - ax - by) + aJ' f(t - ax - c_1y) \\ \eta &= aI f(t - ax + by) + aI' f(t - ax - by) + cJ' f(t - ax - c_1y) \end{aligned} \right\} \quad (20),$$

and in the lower medium

$$\left. \begin{aligned} \xi &= b_1I_1 f(t - ax + b_1y) + aJ_1 f(t - ax + c_1y) \\ \eta &= aI_1 f(t - ax + b_1y) - c_1J_1 f(t - ax + c_1y) \end{aligned} \right\} \dots \quad (21),$$

where I, I', I_1, J', J_1 , denote five constant coefficients. The notation J' and J_1 is adopted for convenience, to reserve the coefficient J for the case in which the incident wave is condensational, and there is no incident distortional wave. There would be no interest in treating simultaneously the results of two incident waves, one distortional (I) and the other condensational (J).

§ 11. We may make various suppositions as to the interfacial conditions, in respect to displacements of the two mediums and in respect to mutual forces between them. Thus we might suppose free slipping between the two: that is to say, zero tangential force on each medium; and along with this we might suppose equal normal components of motion and of force; and whatever supposition we make as to displacements, we may suppose the normal and tangential forces on either at the interface to be those calculated from the strains according to the ordinary elastic solid theory, or to be those calculated from the rotations and condensations or dilatations, according to the ideal dynamics of ether suggested in the article referred to in the first footnote to § 1. We shall

* Green's 'Math. Papers,' p. 253.

for the present take the case of no interfacial slip, that is, equal values of ξ, η on the two sides of the interface. Remarking now that the argument of f for every one of the five waves is $t - ax$ where $y = 0$, we see that the condition of equality of displacement on the two sides of the interface gives the following equations:—

$$\left. \begin{aligned} b(I - I') + aJ' &= b_1 I_1 + aJ_1 \\ a(I + I') + cJ' &= a_1 I_1 - c_1 J_1 \end{aligned} \right\} \dots \dots (22).$$

§ 12. As to the force-conditions at the interface, I have already given, for ordinary elastic solid or fluid matter * on the two sides of the interface, a complete solution of the present problem in my paper † “On the Reflexion and Refraction of Light” in the ‘Philosophical Magazine’ for 1888 (vol. xxvi.) ; nominally for the case of simple harmonic wave-motion, but virtually including solitary waves as expressed by an arbitrary function: and I need not now repeat the work. At present let us suppose the surface-force on each solid to be that which I have found it must be for ether ‡, if magnetic force is due to rotational displacement of ether, and the lines of magnetic force coincide with axes of rotation of ethereal substance. According to this supposition the two components, Q (normal) and T (tangential), of the mutual force between the mediums, which must be equal on the two sides of the interface, are

$$\left. \begin{aligned} Q &= \kappa \left(\frac{d\xi}{dx} + \frac{d\eta}{dy} \right) = \kappa_1 \left(\frac{d\xi}{dx} + \frac{d\eta}{dy} \right)_1 \\ T &= n \left(\frac{d\eta}{dx} - \frac{d\xi}{dy} \right) = n_1 \left(\frac{d\eta}{dx} - \frac{d\xi}{dy} \right)_1 \end{aligned} \right\} \dots \dots (23),$$

where κ denotes for ether that which for the elastic solid we have denoted by $(k + \frac{4}{3}n)$, and suffixes indicate values for the lower medium. If we begin afresh for ether, we may define n as $1/4\varpi$ of the torque required to hold unit of volume of ether rotated through an infinitesimal angle ϖ from its

* The force-conditions for this case are as follows:—

Normal component force equated for upper and lower mediums,

$$(k - \frac{2}{3}n)\delta + 2n \frac{d\eta}{dy} = (k_1 - \frac{2}{3}n_1)\delta_1 + 2n_1 \left(\frac{d\eta}{dy} \right)_1;$$

and tangential forces equated,

$$n \left(\frac{d\eta}{dx} + \frac{d\xi}{dy} \right) = n_1 \left(\frac{d\eta}{dx} + \frac{d\xi}{dy} \right)_1.$$

† In that paper B, A, and ζ denote respectively the n , the $k + \frac{4}{3}n$, and the ρ of the present paper.

‡ See first footnote to § 1.

orientation of equilibrium, and κ as the bulk-modulus, that is to say, the reciprocal of the compressibility, of ether. Thus we now have as before in equations (15), (11), and (18)

$$\left. \begin{aligned} \alpha^2 + b^2 = u^{-2} = \frac{\rho}{n}; & \quad \alpha^2 + b_1^2 = u_1^{-2} = \frac{\rho_1}{n_1} \\ \alpha^2 + c^2 = v^{-2} = \frac{\rho}{\kappa}; & \quad \alpha^2 + c_1^2 = v_1^{-2} = \frac{\rho_1}{\kappa_1} \end{aligned} \right\} \quad (24).$$

Using (20) and (21) in (23) with $y=0$ we find

$$\left. \begin{aligned} \kappa(\alpha^2 + c^2)J' = \kappa_1(\alpha^2 + c_1^2)J_1 \\ n(\alpha^2 + b^2)(I + I') = n_1(\alpha^2 + b_1^2)I_1 \end{aligned} \right\} \quad (25);$$

whence by (24)

$$\rho J' = \rho_1 J_1; \quad \rho(I + I') = \rho_1 I_1; \quad (26).$$

By these equations eliminating I_1 and J_1 from (22), we find

$$\left. \begin{aligned} -(b\rho_1 - b_1\rho)I + (b\rho_1 + b_1\rho)I' = a(\rho_1 - \rho)J' \\ a(\rho_1 - \rho)(I + I') = -(c\rho_1 + c_1\rho)J' \end{aligned} \right\} \quad (27);$$

and solving these equations for I' and J' in terms of I , we have

$$\left. \begin{aligned} I' = \frac{(b\rho_1 - b_1\rho)(c\rho_1 + c_1\rho) - a^2(\rho_1 - \rho)^2}{(b\rho_1 + b_1\rho)(c\rho_1 + c_1\rho) + a^2(\rho_1 - \rho)^2} I \\ J' = \frac{-2ab\rho_1(\rho_1 - \rho)}{(b\rho_1 + b_1\rho)(c\rho_1 + c_1\rho) + a^2(\rho_1 - \rho)^2} I \end{aligned} \right\} \quad (28),$$

and with J' and I' thus determined, (26) give J_1 and I_1 , completing the solution of our problem.

§ 13. Using (18) to eliminate a , b , b_1 , c , and c_1 , from (28), and putting

$$\frac{\rho_1 - \rho}{\rho_1 \cot j + \rho \cot j_1} = h \quad (29);$$

we find

$$\frac{I'}{I} = \frac{\rho_1 \cot i - \rho \cot i_1 - h(\rho_1 - \rho)}{\rho_1 \cot i + \rho \cot i_1 + h(\rho_1 - \rho)} \quad (30),$$

and

$$\frac{J_1}{I} = \frac{-2h\rho_1 \cot i}{\rho_1 \cot i + \rho \cot i_1 + h(\rho_1 - \rho)} \quad (31).$$

Consider now the case of v and v_1 very small in comparison with u and u_1 ; which by (28) makes

$$\cot j \doteq 1/va, \quad \text{and} \quad \cot j_1 \doteq 1/v_1a \quad (32).$$

This gives

$$h \doteq \frac{(\rho_1 - \rho) \sin i}{\rho_1 \frac{u}{v} + \rho \frac{u}{v_1}} \dots \dots \dots (33),$$

which is a very small numeric. Hence J' is very small in comparison with I ; and

$$\frac{I'}{I} \doteq \frac{\rho_1 \cot i - \rho \cot i_1}{\rho_1 \cot i + \rho \cot i_1} \dots \dots \dots (34).$$

§14. If the rigidities of the two mediums are equal, we have $\rho_1 / \rho = \sin^2 i / \sin^2 i_1$, and (34) becomes

$$\frac{I'}{I} = \frac{\sin 2i - \sin 2i_1}{\sin 2i + \sin 2i_1} = \frac{\tan (i - i_1)}{\tan (i + i_1)} \dots \dots (35);$$

which is Fresnel's "tangent-formula." On the other hand, if the densities are equal, (34) becomes

$$\frac{I'}{I} = \frac{-\sin (i - i_1)}{\sin (i + i_1)} \dots \dots \dots (36),$$

which is Fresnel's "sine-formula"; a very surprising and interesting result. It has long been known that *for vibrations perpendicular* to the plane of the incident, reflected, and refracted rays, unequal densities with equal rigidities of the two mediums, whether compressible or incompressible, gives Fresnel's sine-law: and unequal rigidities, with equal densities, gives his tangent-law. But for vibrations *in the plane* of the three rays, and both mediums incompressible, unequal rigidities with equal densities give, as was shown by Rayleigh in 1871*, a complicated formula for the reflected ray, vanishing for two different angles of incidence, if the motive forces in the waves are according to the law of the elasticity of an ordinary solid. Now we find for vibrations *in the plane of the rays*, Fresnel's sine-law, with its continual increase of reflected ray with increasing angles of incidence up to 90°, if the restitutional forces follow the law of dependence on rotation which I have suggested † for ether, and if the waves of condensation and rarefaction travel at velocities small in comparison with those of waves of distortion.

§15. Interesting, however, as this may be in respect to an ideal problem of dynamics, it seems quite unimportant in the wave-theory of light; because Stokes ‡ has given, as I

* Phil. Mag. 1871, 2nd half year.

† "On the Reflexion and Refraction of Light," Phil. Mag. vol. xxvi. 1888.

‡ "Dynamical Theory of Diffraction." See footnote §5.

believe, irrefragable proof that in light polarized by reflexion the vibrations are perpendicular to the plane of the incident and reflected rays, and therefore, that it is for vibrations *in this plane* that Fresnel's tangent-law is fulfilled.

§16. Of our present results, it is (35) of §14 which is really important; inasmuch as it shows that Fresnel's tangent-law is fulfilled for vibrations in the plane of the rays, with the rotational law of force, as I had found it in 1888 * with the elastic-solid-law of force, provided only that the propagational velocities of condensational waves are small in comparison with those of the waves of transverse vibration which constitute light.

§17. By (28) we see that when a^{-1} , the velocity of the wave-trace on the interface of the two mediums, is greater than the greatest of the wave-velocities, each of b, b', c, c' is essentially real. A case of this character is represented by fig. 2, in which the velocities of the condensational waves in both mediums are much smaller than the velocity of the refracted distortional wave, and this is less than that of the incident wave which is distortional. When one or more of b, b', c, c' is imaginary, our solution (26) (28) remains valid, but is not applicable to f regarded as an arbitrary function; because although $f(t)$ may be arbitrarily given for every real value of t , we cannot from that determine the real values of

$$f(t + \iota q) + f(t - \iota q) \quad . \quad . \quad . \quad . \quad (37),$$

and

$$\iota \{ f(t + \iota q) - f(t - \iota q) \} \quad . \quad . \quad . \quad . \quad (38).$$

The primary object of the present communication was to treat this case in a manner suitable for a single incident *solitary* wave whether condensational or distortional; instead of in the manner initiated by Green and adopted by all subsequent writers, in which the realized results are immediately applicable only to cases in which the incident wave-motion consists of *an endless train of simple harmonic waves*. Instead, therefore, of making f an exponential function as Green made it, I take

$$f(t) = \frac{1}{t + \iota \tau} \quad . \quad . \quad . \quad . \quad (39),$$

where τ denotes an interval of time, small or large, taking the place of the "transit-time" (§7 above), which we had for the case of a solitary wave-motion starting from rest, and coming to rest again for any one point of the medium after an interval of time which we denoted by τ .

* See footnote §14.

§18. Putting now

$$I = p + iq \quad \dots \dots \dots (40);$$

and from this finding I', I'', J', J'' ; and taking for the real incident wave-motion (§10 above)

$$\left. \begin{aligned} \frac{\xi}{b} = \frac{\eta}{a} &= \frac{1}{2} \left[\frac{p + iq}{t - ax + by + i\tau} + \frac{p - iq}{t - ax + by - i\tau} \right] \\ &= \frac{p(t - ax + by) + q\tau}{(t - ax + by)^2 + \tau^2} \end{aligned} \right\} (41),$$

being the mean of the formulas for $+i$ and $-i$; we find a real solution for any case of b, c, c' , some or all of them imaginary.

§19. Two kinds of incident solitary wave are expressed by (41), of types represented respectively by the following elementary algebraic formulas:—

$$\frac{t - ax + by}{(t - ax + by)^2 + \tau^2} \quad \dots \dots \dots (42),$$

and

$$\frac{\tau}{(t - ax + by)^2 + \tau^2} \quad \dots \dots \dots (43).$$

The same formulas represent real types of condensational waves with ξ/a and $\eta/(-c)$, instead of the ξ/b and η/a of (41) which relates to distortional waves. It is interesting to examine each of these types and illustrate it by graphical construction: and particularly to enquire into the distribution of energy, kinetic and potential, for different times and places in a wave. Without going into details we see immediately that both kinetic and potential energy are very small for any value of $(t - ax + by)^2$ which is large in comparison with τ^2 . I intend to return to the subject in a communication regarding the diffraction of solitary waves, which I hope to make at a future meeting.

§20. It is also very interesting to examine the type-formulas for disturbance in either medium derived from (41) for reflected or refracted waves when b, c , or c' is imaginary. They are as follows, for example if $b = iq$, where g is real;

$$\frac{t - ax}{(t - ax)^2 + (gy + \tau)^2} \quad \dots \dots \dots (44),$$

and

$$\frac{gy + \tau}{(t - ax)^2 + (gy + \tau)^2} \quad \dots \dots \dots (45).$$

These real resultants of imaginary waves are not plane waves. They are forced linear waves sweeping the interface, on which they travel with velocity a^{-1} ; and they produce disturbances penetrating to but small distances into the medium to which they belong. Their interpretation in connexion with total internal reflexion, both for vibrations in the plane of the rays, and for the simpler case of vibrations perpendicular to this plane (for which there is essentially no condensational wave) constitutes the dynamical theory of Fresnel's rhomb for solitary waves.

XIII. *Notes on Platinum Thermometry*. By H. L. CALLENDAR, M.A., F.R.S., Quain Professor of Physics, University College, London*.

SINCE the date of the last communication, which I made to this Journal in February 1892, I have been continually engaged in the employment of platinum thermometers in various researches. But although I have exhibited some of my instruments at the Royal Society and elsewhere and have described the results of some of these investigations, I have not hitherto found time to publish in a connected form an account of the construction and application of the instruments themselves, or the results of my experience with regard to the general question of platinum thermometry. As the method has now come into very general use for scientific purposes, it may be of advantage at the present time to collect in an accessible form some account of the progress of the work, to describe the more recent improvements in methods and apparatus, and to discuss the application and limitations of the various formulæ which have from time to time been proposed.

The present paper begins with a brief historical summary, with the object of removing certain common misapprehensions and of rendering the subsequent discussion intelligible. It then proceeds to discuss various formulæ and methods of reduction, employing in this connexion a proposed standard notation and nomenclature, which I have found convenient in my own work. I hope in a subsequent paper to describe some of the more recent developments and applications of the platinum thermometer, more particularly those which have occurred to me in the course of my own work, and which have not as yet been published or described elsewhere.

* Communicated by the Author.

Historical Summary.

The earlier experiments on the variation of the electrical resistance of metals with temperature were either too rough, or too limited in range, to afford any satisfactory basis for a formula. The conclusion of Lenz (1838), that the resistance reached a maximum at a comparatively low temperature, generally between 200° and 300° C., was derived from the empirical formula,

$$R^{\circ}/R = 1 + at + bt^2, \quad \dots \dots \dots (L)$$

in which R° and R stand for the resistances at 0° and t° C., respectively. This conclusion resulted simply from the accident that he expressed his results in terms of *conductivity* instead of resistance, and could be disproved by the roughest qualitative experiments at temperatures beyond the range 0° to 100° C., to which his observations were restricted. Matthiessen (1862), in his laborious and extensive investigations, also unfortunately fell into the same method of expression. His results have been very widely quoted and adopted, but, owing to the extreme inadequacy of the formula, the accuracy of his work is very seriously impaired even within the limits of the experimental range to which it was confined. The so-called Law of Clausius, that the resistance of pure metals varied as the absolute temperature, was a generalization founded on similarly incomplete data. The experiments of Arndtsen (1858), by which it was suggested, gave, for instance, the temperature-coefficients $\cdot 00394$ for copper, $\cdot 00341$ for silver and $\cdot 00413$ for iron, all of which differ considerably from the required coefficient $\cdot 003665$. The observations, moreover, were not sufficiently exact to show the deviation of the resistance-variation from lineality. The experiments of Sir William Siemens (1870) did not afford any evidence for the particular formula which he proposed, at least in the case of iron. These formulæ have been already discussed in previous communications*, but considering the extent to which they are still quoted, it may be instructive to append the curves representing them, as a graphic illustration of the danger of applying for purposes of extrapolation formulæ of an unsuitable type. The curves labelled Morris† and Benoit, which are of the same general character but differ in steepness, may be taken as representing approximately the resistance-variation of specimens of pure and impure iron respectively.

The first experiments which can be said to have afforded any satisfactory basis for a general formula were those of

* Callendar, *Phil. Mag.* July 1891; G. M. Clark, *Electrician*, Jan. 1897.

† *Phil. Mag.* Sept. 1897, p. 213.

Benoit (*Comptes Rendus*, 1873, p. 342). Though apparently little known and seldom quoted, his results represent a great advance on previous work in point of range and accuracy.

Fig. 1.

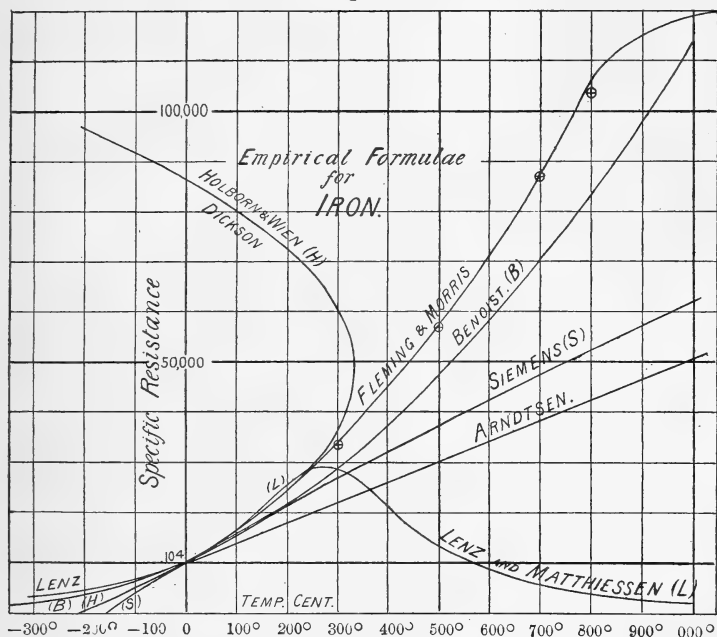

The wires on which he experimented were wound on clay cylinders and heated in vapour-baths of steam (100°), mercury (360°), sulphur (440°), and cadmium (860°), and in a liquid bath of mercury for temperatures below 360°. The resistances were measured by means of a Becquerel differential galvanometer and a rheostat consisting of two platinum wires with a sliding mercury-contact. It is evident that the values which he assumed for the higher boiling-points are somewhat rough. The boiling-point attributed to cadmium, following Deville and Troost, is about 50° too high according to later experiments by the same authorities, or about 90° too high according to Carnelley and Williams. It would appear also that no special precautions were taken to eliminate errors due to thermoelectric effects, to changes in the resistance of the leading wires, and to defective insulation, &c. In spite of these obvious defects it is surprising to find how closely the results as a whole agree with the observations of subsequent investigators. The resistance-variation of all the more common

metals, according to Benoit, is approximately represented by an empirical formula of the type

$$R/R^{\circ} = 1 + at + bt^2, \quad (B)$$

where R is the resistance at any temperature t , and R° the resistance at 0° C. The values of the constants a and b which he gives for iron and steel represent correctly (in opposition to the formula of Siemens) the very rapid increase in the rate of change of resistance with temperature, as shown by the relatively large positive value of the coefficient b . He gives also in the case of platinum a small negative value for b (a result since abundantly confirmed), although the specimen which he used was evidently far from pure*. This formula, which is the most natural to adopt for representing the deviations from lineality in a case of this kind, had been previously employed to a limited extent by others for the variation of resistance with temperature; but it had not previously been proved to be suitable to represent this particular phenomenon over so extended a range.

The work of the Committee of the British Association in 1874 was mainly confined to investigating the changes of zero of a Siemens pyrometer when heated in an ordinary fire to moderately elevated temperatures. Finding that the pyrometer did not satisfy the fundamental criterion of giving always the same indication at the same temperature, it did not seem worth while to pursue the method further, and the question remained in abeyance for several years. In the meantime great advances were made in the theory and practice of electrical measurement, so that when I commenced to investigate the subject at the Cavendish Laboratory, the home of the electrical standards, in 1885, I was able to carry out the electrical measurements in a more satisfactory manner, and to avoid many of the sources of error existing in previous work. The results of my investigations were communicated to the Royal Society in June 1886, and were published, with additions, in the 'Philosophical Transactions' of the following year. Owing to a personal accident, no complete abstract of this paper as a whole was ever published; and as the paper in its original form is somewhat long and inaccessible, many of the points it contained have since been overlooked. The greater part of the paper was occupied with the discussion of methods and observations with air-thermometers; but it may not be amiss at the present time to give a summary of the main conclusions

* It may be remarked that the sign of this coefficient for platinum and palladium is wrongly quoted in Wiedemann, *Electricität*, vol. i. p. 525.

which it contained, so far as they relate to the subject of platinum thermometry.

(1) It was shown that a platinum resistance-thermometer, if sufficiently protected from strain and contamination, was practically free from changes of zero over a range of 0° to 1200° C., and satisfied the fundamental criterion of giving always the same indication at the same temperature.

(2) It was proposed to use the platinum thermometer as a secondary standard, the temperature pt on the platinum scale being defined by the formula

$$pt = 100(R - R^{\circ}) / (R' - R^{\circ}), \dots (1)$$

in which the letters R , R° , R' stand for the observed resistances at the temperatures pt , 0° , and 100° C. respectively.

(3) By comparing the values of pt deduced from different pairs of specimens of platinum wires, wound side by side and heated together in such a manner as to be always at the same temperature, it was shown that different wires agreed very closely in giving the same value of any temperature pt on the platinum scale, although differing considerably in the values of their temperature-coefficients. (See below, p. 209.)

(4) A direct comparison was made between the platinum scale and the scale of the air-thermometer by means of several different instruments, in which the coil of platinum wire was enclosed inside the bulb of the air-thermometer itself, and so arranged as to be always at the same mean temperature as the mass of air under observation. As the result of this comparison, it was shown that the small deviations of the platinum scale from the temperature t by air-thermometer could be represented by the simple difference-formula

$$D = t - pt = d(t/100 - 1)t/100, \dots (2)$$

with a probable error of less than 1° C. over the range 0° to 650° C.

(5) It was inferred from the comparisons of different specimens of wire referred to in (3) (which comparisons were independent of all the various sources of error affecting the air-thermometer, and could not have been in error by so much as a tenth of a degree) that the simple parabolic formula did not in all cases represent the small residual differences between the wires.

(6) It was shown by the direct comparison of other typical metals and alloys with platinum, that the temperature-variation of the resistance of metals and alloys in general could probably be represented by the same type of formula over a considerable range with nearly the same order of accuracy as in the

case of platinum. But, that the formula did not represent singularities due to change of state or structure, such as those occurring in the case of iron at the critical temperature, or in the case of tin at the point of fusion.

This paper attracted very little attention until the results were confirmed by the independent observations of Griffiths*, who in 1890 applied the platinum thermometer to the determination of certain boiling- and freezing-points, and to the testing of mercury thermometers of limited scale. The results of this work appeared at first to disagree materially with the difference-formula already quoted, the discrepancy amounting to between 6° and 7° at 440° C. After his work had been communicated to the Royal Society a direct comparison was made with one of my thermometers in his apparatus; and the discrepancy was traced to the assumption by Griffiths of Regnault's value $448^{\circ}\cdot38$ C. for the boiling-point of sulphur. We therefore undertook a joint redetermination of this point with great care, employing for the purpose one of my original air-thermometers which had been used in the experiments of 1886. The results of this determination were communicated to the Royal Society in December 1890, and brought the observations of Griffiths into complete harmony with my own and with the most accurate work of previous observers on the other boiling- and freezing-points in question. The agreement between his thermometers when reduced by the difference-formula (2), employing for each instrument the appropriate value for the difference-coefficient d , was in fact closer than I had previously obtained with platinum wires from different sources. But the agreement served only to confirm the convenience of the method of reduction by means of the Sulphur Boiling-Point (S.B.P.) which we proposed in that paper †.

Proposed Standard Notation and Nomenclature.

It will be convenient at this stage, before proceeding to discuss the results of later work, to explain in detail the notation and phraseology which I have found to be useful in connexion with platinum thermometry. This notation has already in part been adopted by the majority of workers in the platinum scale, and it would be a great saving in time and space if some standard system of the kind could be generally recognized. In devising the notation special attention has been paid to the limitations of the commercial typewriter, as the majority of communications to scientific societies at

* Phil. Trans. clxxxii. (1891), A, pp. 43-72.

† *Ibid.* t.c. pp. 119-157.

the present time are required to be typewritten. It is for this reason desirable to avoid, wherever possible, the use of Greek letters and subscript diacritics and indices.

The Fundamental Interval.—The denominator, $R' - R^{\circ}$, in formula (1) for the platinum temperature pt , represents the change of resistance of the thermometer between 0° and 100° C., and is called the fundamental interval of the thermometer, in accordance with ordinary usage. It is convenient, as suggested in a previous communication, to adjust the resistance of each thermometer, and to measure it in terms of a unit such that the fundamental interval is approximately 100. The reading of the instrument will then give directly the value of pt at any temperature, subject only to a small percentage correction for the error of adjustment of the fundamental interval.

The Fundamental Coefficient.—The mean value of the temperature-coefficient of the change of resistance between 0° and 100° C. is called the fundamental coefficient of the wire, and is denoted by the letter c . The value of c is given by the expression $(R' - R^{\circ})/100 R^{\circ}$. The value of this coefficient is not necessary for calculating or reducing platinum temperatures, but it is useful for identifying the wire and as giving an indication of its probable purity.

The Fundamental Zero.—The reciprocal of the fundamental coefficient c is called the fundamental zero of the scale of the thermometer, and is denoted by the symbol pt° , so that $pt^{\circ} = 1/c$. The fundamental zero, taken with the negative sign, represents the temperature on the scale of the instrument itself at which its resistance would vanish. It does not necessarily possess any physical meaning, but it is often more convenient to use than the fundamental coefficient (*e. g.*, *Phil. Trans. A*, 1887, p. 225). It may be remarked that, if the resistance has been accurately adjusted so that the fundamental interval is 100 units, R° , the resistance at 0° C., will be numerically equal to pt° .

The Difference Formula.—It is convenient to write the formula for the difference between t and pt in the form already given (2), as the product of three factors, $d \times (t/100 - 1) \times t/100$, rather than in the form involving the square of $t/100$, which I originally gave, and which has always been quoted. Owing to the form in which it was originally cast, I find that most observers have acquired the habit of working the formula in the following manner. First find the square of $t/100$, then subtract $t/100$, writing the figures down on paper, and finally multiply the difference by the difference-coefficient d with the aid of a slide-rule. It is very much easier to work

the formula as the product of three factors, because the subtraction $(t/100-1)$ can be safely performed by mental arithmetic. The whole process can then be performed by one application of the slide-rule, instead of two, and it is unnecessary to write down any intermediate steps on paper.

The Parabolic Function.—It is convenient to have an abbreviation for the parabolic function of t vanishing at 0° and 100° , which occurs so frequently in questions of thermometry. I have found the abbreviation $p(t)$ both suggestive and useful for this purpose. The formula may then be written in the abbreviated shape, $t = pt + d \times p(t)$.

The "S.B.P." Method of Reduction.—Assuming the difference-formula, the value of the difference-coefficient d may be determined by observing the resistance R'' , and calculating the corresponding value of the platinum temperature pt'' , at some secondary fixed point t'' , the temperature of which is known on the scale of the gas-thermometer. The boiling-point of sulphur (S.B.P.) is generally the most convenient to use, and has been widely adopted for this purpose. Assuming that this point is chosen for the purpose, and that the height of the barometer at the time is $760 + h$ millims., the corresponding temperature is given by the formula

$$t'' = 444.53 + .082 h,$$

provided that h is small, and the corresponding value of the parabolic function by the formula

$$p(t'') = 15.32 + .0065 h,$$

whence $d = (t'' - pt'')/p(t'')$.

With the best apparatus it is possible to attain an order of accuracy of about 0.1 per cent. in the value of d obtained by this method, at least in the case of thermometers which are not used at temperatures above 500° . At higher temperatures the exact application of the formula would be more open to question, and it may be doubted whether the value of the difference-coefficient would remain constant to so small a fraction of itself.

Other Secondary Fixed Points.—For very accurate work between 0° and 100° C. it might be preferable to use a value of d determined at 50° C., either by direct comparison with an air-thermometer or by comparison with a standard platinum thermometer. The latter comparison would be much the easier and more accurate. Although the most careful comparisons have hitherto failed to show that the value of d obtained by assuming the S.B.P. does not give correct results

between 0° and 100° C., it is quite possible that this might not always be the case.

For work at low temperatures it would be preferable, from every point of view, to make use of the boiling-point of oxygen as the secondary fixed point. There appears to be a very general consensus of opinion that the temperature of *liquid* oxygen boiling under a pressure of 760 mm. is $-182^{\circ}\cdot5$ C., on the scale of the constant-volume hydrogen or helium thermometer*. It is quite possible that, as in the case of water and most other liquids, the temperature of the boiling liquid would be different from that of the condensing vapour at the same pressure; but the boiling liquid is the most convenient to employ, and it appears that its temperature is steady to two or three tenths of a degree, and reproducible by different observers to a similar order of accuracy. I have found it convenient for purposes of distinction to employ the symbol d° to denote the value of d deduced from the boiling-point of oxygen, and the symbol d'' to denote that deduced from the boiling-point of sulphur. The formulæ for the pressure correction in the case of oxygen are approximately

$$t = -182\cdot5 + \cdot020 h; \quad p(t) = 5\cdot16 - \cdot00093h.$$

The Resistance Formula.—I have shown in the paper already referred to that the adoption of the parabolic difference-formula for the relation between pt and t is equivalent to assuming for the resistance-variation the formula

$$R/R^{\circ} = 1 + at + bt^2. \quad . \quad . \quad . \quad . \quad . \quad (3)$$

The values of the coefficients a and b are found in terms of c and d , or *vice versa*, by means of the relations

$$a = c(1 + d/100), \quad b = -cd/10,000.$$

Graphic Method of Reduction.—The quickest and most generally convenient method of reducing platinum temperatures to the air-scale is to plot the difference $t-pt$ in terms of t as abscissa, and to deduce graphically the curve of difference in terms of pt as abscissa, as described and illustrated in my original paper. This method is particularly suitable at temperatures up to 500° C., as the difference over this range is relatively small and accurately known. It is also very convenient if a large number of determinations are to be made with a single instrument. It is not so convenient in the case of a number of different instruments with different coefficients,

* The experimental evidence for this number is not quite satisfactory, owing to differences in the atmospheric pressure and impurities in the oxygen. It must be understood that the adoption of this value is provisional and subject to correction.

each of which is used for a comparatively limited number of determinations. In such a case the trouble of drawing the separate curves, with sufficient care to be of use, would more than counterbalance the advantage to be gained by the method.

Heycock and Neville's Method.—In order to avoid this difficulty Messrs. Heycock and Neville, in their classical researches at high temperatures* devised an ingenious modification of procedure, which has given very good results in their hands, but is not quite identical with the simple difference-formula. They described a difference-curve in the usual manner, giving the value of the difference in terms of pt as abscissa for a standard value $d=1.50$ of the difference-coefficient. The appropriate values of d were determined in the case of each pyrometer by the S.B.P. method. In reducing the observations for any given values of pt and d , the value of the difference corresponding to pt was taken from the curve for $d=1.50$, and was then multiplied by the factor $d/1.50$ and added to pt . This method is very expeditious and convenient, and gives results which are in practical agreement with the pure difference-formula, provided that, as was almost invariably the case in their observations, the values of d do not differ materially from the average 1.50. If, however, the pure difference-formula is correct, the method could not be applied in the case of values of d differing considerably from the average. The difference between the methods cannot be simply expressed in terms of either pt or t for considerable variations in the value of d . But for a small variation δd in the value of d in the vicinity of the normal value, it is easy to show that the difference δt between the true value of t as given by the difference-formula $t-pt=d p(t)$, and the value found by the method of Heycock and Neville, is approximately

$$\delta t = \delta d (dt/dpt - 1) p(t) \dagger.$$

Neglecting the variation of d entirely, the error would be

$$\delta' t = \delta d (dt/dpt) p(t).$$

For example, at $t=1000^\circ$, $p(t)=90$, $(dt/dpt)=1.40$, we should find for a variation of d from 1.50 to 1.60, the values $\delta t=3^\circ.8$ (H. & N.), and $\delta' t=12^\circ.8$ (variation neglected).

This is an extreme case. In the observations of Heycock and Neville, the values found for the coefficient d seldom

* Trans. Chem. Soc. Feb. 1895, p. 162.

† The value of dt/dpt at any point is readily found by differentiating the difference-formula (2), $dpt/dt=1-(t/50-1)d/100$.

varied so much as '04 on either side of the mean, in the case of their standard wire. It is, moreover, quite possible that these variations may have been partly due to fortuitous differences at the S.B.P. and at the fixed points, in which case it is probable that the Heycock and Neville method of reduction would lead to more consistent results than the pure difference-formula, because it does not allow full weight to the apparent variations of d as determined by the S.B.P. observations. It is clearly necessary, as Heycock and Neville have shown, and as the above calculation would indicate, to take some account of the small variations of d , at least in the case of pyrometers in constant use at high temperatures. The method of Heycock and Neville appears to be a very convenient and practical way of doing this, provided that the variations of d are small. It must also be observed that, although the individual reductions by their method may differ by as much as 1° or 2° at 1000° from the application of the pure difference-formula, the average results for the normal value of d will be in exact agreement with it.

Difference-Formula in Terms of pt .—In discussing the variation of resistance as a function of the temperature, it is most natural and convenient to express the results in terms of the temperature t on the scale of the air-thermometer by means of the parabolic formula already given. This formula has the advantage of leading to simple relations between the temperature-coefficients; and it also appears to represent the general phenomenon of the resistance-variation of metals over a wide range of temperature with greater accuracy than any other equally convenient formula. When, however, it is simply a question of finding the temperature from the observed value of the resistance, or from the observed reading of a platinum thermometer, over a comparatively limited range, it is equally natural, and in some respects more convenient, to have a formula which gives t directly in terms of pt or R . This method of expression was originally adopted by Griffiths, who expressed the results of the calibration of his thermometers by means of a formula of the type

$$t - pt = a pt + b pt^2 + c pt^3 + d pt^4. \quad \dots \quad (G)$$

The introduction of the third and fourth powers of pt in this equation was due to the assumption of Regnault's value for the boiling-point of sulphur. If we make a correction for this, the observations can be very fairly represented by a parabolic formula of the type already given, namely,

$$t - pt = d'(pt/100 - 1)pt/100 = d'p(pt). \quad \dots \quad (4)$$

This formula is so simple and convenient, and agrees so closely over moderate ranges of temperature with the ordinary difference-formula, as to be well worth discussion. I have been in the habit of using it myself for a number of years in approximate reductions at moderate temperatures, more particularly in steam-engine and conductivity experiments, in which for other reasons a high degree of accuracy is not required. It has also been recently suggested by Dickson (*Phil. Mag.*, Dec. 1897), though his suggestion is coupled with a protest against platinum temperatures.

The value of the difference-coefficient d' in this formula may be determined as usual by reference to the boiling-point of sulphur, or it may be deduced approximately from the value of the ordinary difference-coefficient d by means of the relation

$$d' = d / (1 - 0.077d), \quad \text{or} \quad d = d' / (1 + 0.077d').$$

If this value is chosen for the coefficient, the two difference-formulæ will of course agree at 0° , 100° , and 445° C., but will differ slightly at other temperatures. The order of agreement between the formulæ is shown at various points of the scale by the annexed table, in which t represents the temperature given by the ordinary formula $t - pt = 1.50p(t)$, and t' the temperature calculated by formula (4) for the same value of pt , choosing the value $d' = 1.695$, to make the two formulæ agree at the S.B.P.

TABLE I.
Comparison of Difference-Formulæ, (2) & (4).

t	-300°	-200°	-100°	$+50^\circ$	200°	300°
$t - t'$...	$-4^\circ.5$	$-1^\circ.95$	$-0^\circ.54$	$+0^\circ.50$	-23°	-42°
t	400°	600°	800°	1000°	1200°	1500°
$t - t'$...	$-.25^\circ$	$+2^\circ.2$	$+9^\circ.3$	$+22^\circ.9$	$+46^\circ.6$	$+97^\circ.2$

It will be observed that the difference is reasonably small between the limits -200° and $+600^\circ$, but that it becomes considerable at high temperatures. A much closer agreement may be readily obtained over small ranges of temperature by choosing a suitable value of d' . The two formulæ become practically indistinguishable between 0° and 100° , for instance, if we make $d' = d$. For steam-engine work I generally selected the value of d' to make the formulæ agree at 200° C.

For work at low temperatures, it would be most convenient to select the boiling-point of oxygen for the determination of either difference-coefficient. The two formulæ are so similar that they cannot be distinguished with certainty over a moderate range of temperature. But if the values of the difference-coefficients are calculated from the S.B.P., the balance of evidence appears to be in favour of the original formula (2). Formula (4) appears to give differences which are too large between 0° and 100° C.; and it does not agree nearly so well as (2) with my own air-thermometer observations over the range 0° to 650° C. It appears also from the work of Heycock and Neville to give results which are too low at high temperatures as compared with those of other observers.

It is obvious, from the similarity of form, that the difference-formula (4) in terms of pt corresponds, as in the case of formula (2), to a parabolic relation between the temperature and resistance, of the type

$$t = -t^\circ + a'R/R^\circ + b'(R/R^\circ)^2 = a''(R/R^\circ - 1) + b''(R/R^\circ - 1)^2. \quad (5)$$

When $R = 0$, $t = -t^\circ = -(a'' - b'')$. Also $b' = b''$, and $a' = a'' - 2b''$.

The values of the fundamental coefficient c , and of the fundamental zero pt° , are of course the same on either formula, provided that they are calculated from observations at 0° and 100° C., but not, if they are calculated from observations outside that range. The values of the coefficients a'' and b'' are given in terms of d' , and either pt° , or c , by the relations

$$a'' = pt^\circ(1 - d'/100) = (1 - d'/100)/c, \quad \text{and} \quad d' = 10,000b''c^2.$$

Formulæ of this general type, but expressed in a slightly different shape, have been used by Holborn and Wien for their observations at low temperatures, and recently by Dickson for reducing the results of Fleming and other observers. But they do not employ the platinum scale or the difference-formula.

Maximum and Minimum Values of the Resistance and Temperature.—It may be of interest to remark that the difference-formulæ (2) and (4) lead to maximum or minimum values of pt and t respectively, which are always the same for the same value of d , but lie in general outside the range of possible extrapolation. In the case of formula (2), the resistance reaches a maximum at a temperature $t = -a/2b = (5000/d)(1 + d/100)$. The maximum values of pt and R are given in terms of d and c by the equations

$$pt \text{ (max.)} = (1 + d/100) t/2 = (2500/d)(1 + d/100)^2,$$

$$R/R^\circ \text{ (max.)} = 1 + pt \text{ (max.)}/pt^\circ = 1 + (2500c/d)(1 + d/100)^2.$$

Similarly in the case of the difference-formula (4) in terms of pt , the maximum or minimum value of t is given in terms of d' by the equation

$$t(\text{max.}) = (1 - d'/100) pt/2 = - (2500/d') (1 - d'/100)^2.$$

Dickson's Formula.—In a recent number of this Journal (Phil. Mag., Dec. 1897) Mr. Dickson has proposed the formula

$$(R + a)^2 = p(t + b). \quad \dots \dots (6)$$

He objects to the usual formula (3) on the grounds, (1) that it leads to a maximum value of the resistance in the case of platinum at a temperature of about $t = 3250^\circ \text{C.}$, and (2) that any given value of the resistance corresponds to *two* temperatures. He asserts that “both of these statements indicate physical conditions which we have no reason to suppose exist.” In support of contention (1), he adduces a rough observation of Holborn and Wien* to the effect that the

* Wied. Ann. Oct. 1895, p. 386. Mr. Dickson and some other writers appear to attach too much weight to these observations of Messrs. Holborn and Wien. So far as they go, they afford a very fair confirmation of the fundamental principles of platinum-thermometry at high temperatures; but the experiments themselves were of an incidental character, and were made with somewhat unsuitable apparatus. Only two samples of wire were tested, and the resistances employed were too small for accurate measurement. The wires were heated in a badly-conducting muffle and were insulated by capillary tubes of porcelain or similar material. The temperature of the wire under test was assumed to be the mean of the temperatures indicated by two thermo-junctions at its extremities; but the authors state that “the distribution of temperature in the furnace was very irregular.” The resistance was measured by a modification of the potentiometer method, and no attempt was made to eliminate residual thermoelectric effects. Under these conditions the observations showed that the resistance was not permanently changed by exposure to a temperature of 1600°C. , at least within the limits of accuracy of the resistance measurements. It is quite easy, however, by electric heating as in the “meldometer,” to verify the difference-formula at high temperatures, with less risk of strain or contamination or bad insulation. (See Petavel, Phil. Trans. A (1898), p. 501.)

The two series of observations (excluding the series in which the tube of the muffle cracked, and the thermocouples and wire were so contaminated with silicon and furnace-gases as to render the observations valueless) overlapped from 1050° to 1250°C. , and showed differences between the two wires varying from 10° to 45° at these temperatures, the errors of individual observations in either series being about 10° to 15° . It must be remembered, however, that the two wires were of different sizes and resistances; they were heated in different furnaces; they were insulated with different materials; and their temperatures were deduced from different thermocouples. Taking these facts into consideration, it is remarkable that the observed agreement should be so close. The observations at the highest temperatures in both cases, with the furnaces full blast and under the most favourable conditions for securing uniformity of temperature throughout the length of the wire, are in very close agreement with the difference-formula (2), assuming $d = 1.75$.

The second specimen was also tested at lower temperatures, but the

resistance of one of their wires had already nearly reached $6R^\circ$ at a temperature of about 1610°C ., whereas the maximum calculated resistance in the case of one of my wires (with a coefficient $c = \cdot 00340$) was only $6\cdot 576 R^\circ$. He omits to notice that the result depends on the coefficients of the wire.

The wire used by Holborn and Wien had a fundamental coefficient $c = \cdot 00380$, and the highest value of the resistance actually observed was not $6R^\circ$ as suggested, but $R/R^\circ = 5\cdot 53$, at a temperature $t = 1610^\circ \text{C}$., deduced from thermo-junctions at each end. If we assume $d = 1\cdot 70$ as a probable value of the difference-coefficient for their wire, the difference-formula (2) would give,

at $t = 1610^\circ$, $D = 414^\circ$, $pt = 1196^\circ$, whence $R/R^\circ = 5\cdot 54$.

It would be absurd to attach much weight to so rough an observation, but it will be seen that, so far as it goes, the result is consistent with the usual formula, and does not bear out Mr. Dickson's contention. A more important defect in arguments (1) and (2) lies in the fact that maximum and minimum values of the resistance are known to occur in the case of manganin and bismuth within the experimental range, and that such cases can be at least approximately represented by a formula of the type (3), but cannot be represented by a formula of the type (6).

As shown by Table I. above, the formula proposed by Dickson agrees fairly well with formula (3), in the special case of platinum, through a considerable range. But the case of platinum is exceptional. If we attempt to apply a formula of Dickson's type to the case of other metals, we are met by practical difficulties of a serious character, and are driven to conclude that the claim that it is "more representative of the connexion between temperature and resistance than any formula hitherto proposed," cannot be maintained.

observations are somewhat inconsistent, and lead to values of d which are rather large and variable, ranging from $3\cdot 7$ to $2\cdot 6$. These variations are probably due to errors of observation or reduction. This is shown by the work of Mr. Tory (B.A. Report, 1897), who made a direct comparison between the Pt—PtRh thermocouple and the platinum-thermometer by a much more accurate method than that of Holborn and Wien. He found the parabolic difference-formula for the platinum thermometer to be in very fair agreement between 100° and 800°C . with the previous series of observations of Holborn and Wien on this thermocouple (Wied. *Ann.* 1892), and there can be little doubt that the discrepancies shown by their later tests were due chiefly to the many obvious defects of the method. For a more detailed criticism of these observations, the reader should refer to a letter by Griffiths in 'Nature,' Feb. 27th, 1896. It is sufficient to state here that the conclusions which these observers drew from their experiments are not justified by the observations themselves.

If, for instance, we take the observations of Fleming on very pure iron between 0° and 200° C., and calculate a formula of the Holborn and Wien, or Dickson, type to represent them, we arrive at a curve similar to that shown in fig. 1 (p. 193). (The values of the specific resistance of Fleming's wire are reduced, for the sake of comparison, to the value $R=10,000$ at 0° C.) This curve agrees very closely with that of Morris and other observers between 0° and 200° C. The peculiarities of the curve beyond this range are not due to errors in the data, but to the unsuitable nature of the formula. A similar result would be obtained in the case of iron by employing any other sufficiently accurate data. It will be observed that the formula leads to a maximum value of the temperature $t=334^{\circ}$, and makes the resistance vanish at -197° . Below 334° there are *two* values of the resistance for each value of the temperature, and the value of dR/dt at 334° is infinite, both of which conditions are at present unknown in the case of any metal, and are certainly not true in the case of iron. If, instead of taking the value observed at $+196^{\circ}\cdot 1$ C., we take the value obtained at the O.B.P. to calculate the formula, we should find a better agreement with observation at low temperatures, but the disagreement at higher temperatures would be greater.

If, on the other hand, we take *the same observations*, namely, $c=\cdot 00625$, and $R/R^{\circ}=2\cdot 372$ when $t=196^{\circ}\cdot 1$, and calculate a difference-formula of the type (2) corresponding to (3), we find $d=-12\cdot 5$, $a=\cdot 005467$, $b=\cdot 000,007825$. The points marked \oplus in fig. 1 are calculated from this formula, and are seen to be in practical agreement with the observations of Morris up to 800° . As this formula stands the test of extrapolation so much better than that of Holborn and Wien or Dickson, we are justified in regarding it as being probably more representative of the connexion between resistance and temperature.

Advantages of the Difference-Formula.—Mr. Dickson's objections to the platinum scale and to the difference-formula appear to result from want of familiarity with the practical use of the instrument. But as his remarks on this subject are calculated to mislead others, it may be well to explain briefly the advantages of the method, which was originally devised with the object of saving the labour of reduction involved in the use of ordinary empirical formulæ, and of rendering the results of observations with different instruments directly and simply comparable.

(1) In the first place, a properly constructed and adjusted platinum thermometer reads directly in degrees of temperature

on the platinum scale, just like a mercury thermometer, or any other instrument intended for practical use. The quantity directly observed is not the resistance in ohms, but the temperature on the platinum scale, either pt , or $pt + pt^\circ$. The advantage of this method is that the indications of different instruments become directly comparable, and that the values of pt for different wires agree very closely. If this method is not adopted, the resistances in ohms of different instruments at different temperatures form a series of meaningless figures, which cannot be interpreted without troublesome reductions.

(2) The second advantage of the difference-formula lies in the fact that the difference is *small*, more especially at moderate temperatures, and can be at once obtained from a curve or a table, or calculated on a small slide-rule, without the necessity of minute accuracy of interpolation or calculation. In many cases, owing to the smallness of the difference between the scales, the results of a series of observations can be worked out entirely in terms of the platinum scale, and no reduction need be made until the end of the series. For instance, in an elaborate series of experiments on the variation of the specific heat of water between 0° and 100° C., on which I have been recently engaged, by a method described in the Brit. Assoc. Report, 1897, all the observations are worked out in terms of the platinum scale, and the reduction to the air-scale can be performed by the aid of the difference-formula in half an hour at the end of the whole series. As all the readings of temperature have to be taken and corrected to the ten-thousandth part of a degree, and as the whole series comprises about 100,000 observations, it is clear that the labour involved in Mr. Dickson's method of reduction would have been quite prohibitive. It is only by the general introduction of the method of small corrections that such work becomes practicable.

On the Method of Least Squares.—There appears to be a widespread tendency among non-mathematical observers to regard with almost superstitious reverence the value of results obtained by the method of least squares. This reverence in many cases is entirely misplaced, and the method itself, as commonly applied, very often leads to erroneous results. For instance, in a series of observations extending over a considerable range of temperature, it would be incorrect to attach equal weight to all the results, because all the sources of error increase considerably as we depart further from the fixed points of the scale. In a series of air-thermometer observations, the fixed points themselves stand in quite a different category to the remainder of the observations. The

temperature is accurately known by definition, and is not dependent on uncertain errors of the instrument. It is a mistake, therefore, in reducing a series of observations of this kind, to put all the observations, including the fixed points, on the same footing, and then apply the method of least squares, as Mr. Dickson has applied it in his reduction of the results of various observers with platinum thermometers. For instance, in order to make his formula fit my observations at higher temperatures, he is compelled to admit an error of no less than $0^{\circ}\cdot80$ on the fundamental interval itself, which is quite out of the question, the probable error of observation on this interval being of the order of $0^{\circ}\cdot01$ only. The correct way of treating the observations would be to calculate the values at the fixed points separately, and to use the remainder of the observations for calculating the difference-coefficient. Even here the graphic method is preferable to that of least squares, because it is not easy to decide on the appropriate weights to be attached to the different observations. Correcting the method of calculation in this manner, we should find a series of differences between my observations and Dickson's formula, of the order shown in Table I. It would be at once obvious that the deviations from (6) were of a systematic type, and that it did not represent the results of this series of observations so well as that which I proposed. The deviations shown in Dickson's own table are of a systematic character; but they would have been larger if he had treated the fixed points correctly.

Limitations of the Difference-Formula.—The observations of Messrs. Heycock and Neville at high temperatures may be taken as showing that the simple parabolic difference-formula, in which the value of d is determined by means of the S.B.P. method, gives very satisfactory results, in spite of the severe extrapolation to which it is thus subjected, provided that the wire employed is of pure and uniform quality. If, however, the S.B.P. method of reduction is applied in the case of impure wires at high temperatures, it may lead to differences which are larger than the original differences in the values of pt before reduction. For instance, I made a number of pyrometers some years ago with a sample of wire having the coefficients $c = \cdot00320$, $d'' = 1\cdot75$. My observations on the freezing-points of silver and gold (Phil. Mag., Feb. 1892) were made with some of these pyrometers. All these instruments gave very consistent results, but they could not be brought into exact agreement with those constructed of purer wire by the simple S.B.P. method of reduction, employing either difference-formula (2) or (4). This is not at all

surprising when we consider the very large difference in the fundamental coefficient c , which is approximately $\cdot 00390$ in the case of the purest obtainable wire. The remarkable fact is that, as stated in my original paper (see above, p. 195), the values of pt for such different specimens of wire should show so close an agreement through so wide a range. The difference in the fundamental coefficients in this extreme case is about 20 per cent.; but the values of pt for the two wires differ by only 4° at the S.B.P., and this difference, instead of increasing in proportion to the square of the temperature, remains of the same order, or nearly so, at the freezing-points of silver and gold. Thus the wire $c = \cdot 00320$ gave $pt = 830^\circ$ at the Ag. F.P., but I shortly afterwards obtained with a specimen of very pure wire ($c = \cdot 003897$), the value $pt = 835^\circ$ for the same point. Messrs. Heycock and Neville, using the same pure wire, have confirmed this value. They also find for the F.P. of gold, with different instruments, constructed of the same wire, the average value $pt = 905^\circ \cdot 8$. I did not test this point with the pure wire, but the value found by Messrs. Heycock and Neville may be compared with the value $pt = 902^\circ \cdot 3$ (Phil. Mag., Feb. 1892), which I found at the Mint with one of the old instruments.

From these and other comparisons of the platinum scales of different wires, it appears likely that the deviation of the impure wire from the parabolic curve is generally of this nature. As shown by the comparison curves in my original paper, the deviation follows approximately the parabolic law up to 400° , beyond that point the curves tend to become parallel, and at higher temperatures they often show a tendency to approach each other again. The application of the S.B.P. method of reduction to impure wires at high temperatures will therefore give results which are too high, because the value of d is calculated from the S.B.P., where the difference between the wires is nearly a maximum. Thus, taking the values of d from the S.B.P. for the two specimens of wire above quoted, we find, calculating the values of t for the Ag.F.P., and Au.F.P. from the data,

Impure wire, $c = \cdot 00320$, $d = 1\cdot 751$;

Ag. F.P., $t = 981\cdot 6$; Au. F.P., $t = 1092\cdot 0$.

Pure wire, $c = \cdot 00390$, $d = 1\cdot 520$;

Ag. F.P., $t = 960\cdot 7$; Au. F.P., $t = 1060\cdot 7$.

The results for the impure wire obtained by the S.B.P. method of reduction are not so high as those found by Barus with a Pt-PtIr thermo-element, which he compared with an air-thermometer up to 1050° . There can be little doubt,

however, that they are too high, and that the results given by the pure wire are the more probable. The latter are approximately a mean between the values of Violle 954° , and Holborn and Wien 971° , and may be taken, in the present state of the science of high-temperature measurement, to be at least as probable as any other values, in spite of the extrapolation from 445° , by which they are obtained.

The extrapolation is not really so unreasonable as many observers seem to think. The parabolic formula for resistance variation has been verified for a great variety of cases, through a very wide range, and with much greater accuracy than in the case of many so-called laws of nature. For instance, a similar formula, proposed by Tait and Avernarius, is often regarded as the law of the thermocouple, but the deviations of thermocouples from this law are far wider than those of the most impure platinum thermometer. If we take a Pt-PtRh thermocouple, and apply the S.B.P. method of reduction in the same manner as in the case of a platinum thermometer, taking the data, $t=100^{\circ}$, $e=650$ microvolts; $t=445^{\circ}$, $e=3630$ mv.; we should find $d=-7.4$. At $t=1000^{\circ}\text{C.}$, $e=9550$ mv., the temperature on the scale of the thermocouple is $et=1470^{\circ}$. The temperature calculated by the parabolic formula is $t=804^{\circ}$. Whence it will be seen that the deviation from the formula is about ten times as great as in the case of a very impure platinum wire. A cubic formula was employed by Holborn and Wien to represent their observations at high temperatures with this thermocouple, but even this formula differs by more than 20° from their observations at 150°C. It is, moreover, so unsatisfactory for extrapolation that they preferred to adopt a rectilinear formula for deducing temperatures above 1200°C.

There are, however, more serious objections to the adoption of the thermocouple, except to a limited extent, as a secondary standard:—(1) The scale of the thermocouple is seriously affected, as shown by the observations of Holborn and Wien and Barus at high temperatures, and of Fleming at low temperatures, by variations in the quality of the platinum wire and in the composition of the alloy. (2) The sensitiveness of the Pt—PtRh thermocouple at moderate temperatures is too small to permit of the attainment of the order of accuracy generally required in standard work. (3) No satisfactory method has yet been devised in the case of the thermocouple for eliminating residual thermal effects in other parts of the circuit, which materially limit* the

* My present assistants, Prof. A. W. Porter, B.Sc., and Mr. N. Eumorfopoulos, B.Sc., whose work on Emissivity and Thermal Conductivity has already in part been published in this Journal, employed this thermo-

attainable accuracy. In the case of the platinum thermometer these effects are relatively much smaller, owing to the large change of resistance with temperature, and can be completely eliminated in a very simple manner.

Ag. F.P. Method of Reduction for Impure Wires.—The simplest method of reduction for such wires at high temperatures, would be to take the Ag. F.P. as a secondary fixed point instead of the S.B.P. for the determination of the difference-coefficient d . This would in general lead to a very close agreement at temperatures between 800° and 1200°C ., but would leave residual errors of 3° or 4° at temperatures in the neighbourhood of the S.B.P. To obtain a continuous formula giving results consistent to within less than 1° throughout the range, it would be necessary to adopt the method which I suggested in my last communication (Phil. Mag., Feb. 1892), assuming d to be a linear function of the temperature of the form $a + bt$, and calculating the values of a and b to make the instrument agree with the pure wire at both the S.B.P. and the Ag. F.P., taking the latter as $960^{\circ}\cdot 7$. We should find for the wire ($c = \cdot 00320$) above quoted, $\bar{d} = 1\cdot 580$ at the Ag. F.P. If we apply this value at the Au. F.P., we should find $t = 1063^{\circ}\cdot 0$. But if we employ the second method, and calculate a linear formula for d to make the results agree throughout the scale, taking $d = 1\cdot 751$ at the S.B.P., we obtain $d = a + bt = 1\cdot 898 - \cdot 000331t$. Hence the appropriate value of d to use at the Au. F.P. would be $d = 1\cdot 547$, giving for the Au. F.P. $t = 1060^{\circ}\cdot 0$, which is in closer agreement with the value $1060^{\circ}\cdot 7$ given by the pure wire. This method has also the advantage that it gives practically perfect agreement at the S.B.P., and at all points between 0° and 1000° . In the case of the mercury thermometer, or the thermocouple, a similar cubic formula is required to give an equally good agreement between 0° and 200°C .

In the original paper in which the suggestion was made, I

couple very extensively in their investigations. They inform me that they were compelled to abandon the method shortly before my appointment, because in spite of every precaution which their experience could suggest they found it impossible, owing to these residual thermal effects, to effect a sufficiently accurate calibration of the Pt-PtRh thermocouple at temperatures between 0° and 100°C . The substitution of baser metals such as iron and german-silver at low temperatures would no doubt partly meet this difficulty, but would involve the abandonment of the wide range and constancy and uniformity of scale characteristic of the platinum metals, which are qualifications so essential for a standard. We conclude on these grounds that the application of this thermocouple is limited to high temperatures, and that the contention that it is preferable to the platinum thermometer as a secondary standard cannot be maintained.

assumed tentatively a much lower value $t=945^\circ$ for the Ag. F.P., giving a result $t=1037^\circ$ for the Au. F.P., which naturally does not agree with the results of subsequent work. These results have since been misquoted in a manner which has the effect of suggesting that the platinum thermometer gives very capricious results at high temperatures. Holborn and Wien, for instance, quote my value $981\cdot6$ for the Ag. F.P., obtained with the impure wire by the S.B.P. method of reduction, and at the same time quote the value 1037° for the Au. F.P., which was obtained by assuming the value 945° for the Ag. F.P. Comparing these with the values obtained by Heycock and Neville with the pure wire, one might naturally conclude, in the absence of information as to the manner in which the two results were calculated, that different wires gave very inconsistent results. The truth is, on the contrary, that very different wires agree with remarkable uniformity in giving approximately the same platinum-scale, and that they also give consistent values of t provided that the reduction is effected in a consistent manner. But, although it is evident that this method may be made to give consistent results in the case of impure wires, it is in all cases preferable to use pure wire of uniform quality. If, for instance, a pyrometer gives a value of c less than $\cdot0035$, or a value of d greater than $1\cdot70$, it would be safer to reject it, although it may possibly give very consistent results. Values of d greater than $2\cdot00$ at the S.B.P. sometimes occur, but may generally be taken as implying that the wire is contaminated. Such instruments as a rule deteriorate rapidly, and do not give consistent results at high temperatures.

The Difference-Formula at Low Temperatures.—The suitability of the Platinum thermometer as an instrument for low-temperature research is shown by the work of Dewar and Fleming, and Olszewski. It has also been adopted by Holborn and Wien, in spite of their original prejudice against the instrument. The first verification of the platinum scale at very low temperatures was given by Dewar and Fleming, whose researches by this method are the most extensive and important. They found that two different specimens of wire with fundamental coefficients $c=\cdot00353$, and $c=\cdot00367$ respectively, agreed very closely in giving the same values of the platinum temperature down to -220° . The values of the difference-coefficients for these wires, calculated by assuming $t=-182\cdot5$ for the boiling-point of liquid oxygen, are $d=2\cdot75^*$ and $d=2\cdot72$, respectively. The first of these refers to the particular wire which Dewar and Fleming selected as their standard.

* See below, p. 219, middle, and footnote.

As an illustration of the method of reduction by the difference-formula, it may be of interest to reproduce a table exhibiting in detail the complete calculation of such a table of reduction for the standard wire employed by Dewar and Fleming. We select for this purpose the following corrected data, taken from their paper in the *Phil. Mag.*, July 1895, p. 100.

Thermometer in Melting Ice, $R^{\circ} = 3.1059, t = 0^{\circ} \text{C}$.
 „ Steam at 760 mm., $R' = 4.2034, t = 100^{\circ} \text{C}$.
 „ Liquid Oxygen, $R'' = 0.9473, t = -182^{\circ}.5 \text{C}$.

From these data we deduce :—

Fundamental Interval, $R' - R^{\circ} = 1.0975$.
 Fundamental Coefficient, $(R' - R^{\circ})/100R^{\circ} = .003533$.
 Fundamental Zero, $pt^{\circ} = 1/c = 283^{\circ}.00$.

In Liquid Oxygen,

$pt = -196^{\circ}.7, t = -182^{\circ}.5, D = t - pt = 14^{\circ}.2$.
 Difference-Coefficient, $d = D/p(t) = 14.2/5.16 = 2.75$.
 Difference-Formula, $D = t - pt = 2.75(t/100 - 1)t/100$.

To find the difference-formula in terms of pt , we have similarly,

Difference-Coefficient, $d' = D/p(pt) = 14.2/5.84 = 2.43$.
 Pt Difference-Formula, $D' = t' - pt = 2.43(pt/100 - 1)pt/100$.

As a verification we may take the observation in solid CO_2 and ether, assuming Regnault's value $t = -78^{\circ}.2$ for the true temperature.

Difference-Formula (D) gives, $t - pt = 2.75 \times 1.39 = 3^{\circ}.82$.
 „ „ (D') „ $t' - pt = 2.43 \times 1.49 = 3^{\circ}.62$.

The observed value of pt is given as $-81^{\circ}.9$. Thus the two formulæ give, (D) $t = -78^{\circ}.1$, and (D') $t' = -78^{\circ}.3$, respectively.

The following Table shows the comparison of the formulæ for every ten degrees throughout the range. The first three columns contain the whole work of the calculation for formula (D'). The second column contains the values of D' calculated by the aid of a small slide-rule. These when added to the values of pt in the first column, give the values of t shown in the third column. The fourth column contains the corresponding values of the difference in t for $1^{\circ} pt$, obtained by differentiating the difference-formula. These are written down by the method of differences. The fifth column contains the difference $t - t'$ between the values of t deduced by the two formulæ. The sixth contains the values of t by formula (D); and the seventh is added for comparison with the table given by Dickson (*Phil. Mag.*, June 1898, p. 527).

TABLE II.—Table of Reduction for Dewar and Fleming's Standard Platinum Thermometer.

pt (°C.).	D'.	t' (°C.).	dt/dpt .	$t-t'$.	t (°C.)	Dickson.
+100	0	+100	1·024	0·0	+100	+99·85
+ 50	-0·61	+49·39	1·000	-0·08	+49·31	+49·47
+ 0	0	0	·976	0	0	+ 0·20
- 10	+0·27	- 9·73	·971	+0·03	- 9·70	- 9·51
- 20	+0·58	-19·42	·966	+0·05	-19·37	-19·18
- 30	+0·95	-29·05	·961	+0·08	-28·97	-28·81
- 40	+1·36	-38·64	·956	+0·11	-38·53	-38·39
- 50	+1·82	-48·18	·951	+0·14	-48·04	-47·92
- 60	+2·33	-57·67	·947	+0·17	-57·50	-57·42
- 70	+2·89	-67·11	·942	+0·19	-66·92	-66·83
- 80	+3·50	-76·50	·937	+0·22	-76·28	-76·25
- 90	+4·15	-85·85	·932	+0·23	-85·62	-85·61
-100	+4·86	-95·14	·927	+0·25	-94·89	-94·92
-110	+ 5·60	-104·4	·922	+0·26	-104·1	-104·2
-120	+ 6·41	-113·6	·917	+0·26	-113·3	-113·4
-130	+ 7·28	-122·7	·912	+0·25	-122·5	-122·6
-140	+ 8·14	-131·9	·907	+0·24	-131·6	-131·7
-150	+ 9·12	-140·9	·903	+0·22	-140·7	-140·8
-160	+10·1	-149·9	·898	+0·19	-149·7	-149·8
-170	+11·2	-158·8	·893	+0·16	-158·6	-158·8
-180	+12·3	-167·7	·888	+0·11	-167·6	-167·8
-190	+13·4	-176·6	·883	+0·05	-176·5	-176·7
-200	+14·6	-185·4	·878	-0·02	-185·4	-185·5
-210	+15·8	-194·2	·874	-0·09	-194·3	-194·3
-220	+17·1	-202·9	·869	-0·20	-203·1	-203·1
-230	+18·4	-211·6	·864	-0·31	-211·9	-211·8
-240	+19·8	-220·2	·859	-0·43	-220·6	-220·5
-250	+21·3	-228·7	·855	-0·58	-229·3	-229·1
-260	+22·8	-237·2	·850	-0·73	-237·9	-237·7
-270	+24·3	-245·7	·845	-0·90	-246·6	-246·3
-280	+25·8	-254·2	·840	-1·08	-255·3	-254·8
-283	+26·4	-256·6		-1·16	-257·8	-257·3

The above table affords a good illustration of the point already mentioned, that the results obtained from the two difference-formulæ (D) and (D') agree so closely over a limited range, as in the present case, that it is often quite immaterial which of the two is used for purposes of reduction. The largest difference over the experimental range in the present instance is only 0°·3, which is less than many of the errors of observation, except at the fixed points and under the most favourable conditions. In comparing the two formulæ the following expression for the difference between them is occasionally useful :—

$$D - D' = t - t' = dD(2pt + D - 100)/10,000 + (d/d' - 1)D'.$$

It is generally sufficient to put $D=D'$ on the right-hand side of this formula, so that if either is known the difference between them may be determined with considerable accuracy.

It will be observed that the table of reduction given by Dickson agrees very closely with either of the difference-formulæ. But, on the whole, most closely with (D). If Dickson had calculated his formula from the same data it would have given results *identical* with (D'). By giving equal weight, however, to all the observations, without regard to steadiness of temperature or probable accuracy, he is compelled, as in the previous instance, to admit an error of $0^{\circ}35$ in the fundamental interval itself, which is quite impossible. Except at these points the probable error of his reduction is not of vital importance; on the contrary, the general agreement with (D) is so close that it is difficult to see on what grounds he can regard the latter as being either incorrect or inadequate.

For practical purposes a table of this kind is not convenient owing to the continual necessity for interpolation. A graphic chart in which t is plotted directly against pt is objectionable, because it does not admit of sufficient accuracy unless it is plotted on an unwieldy scale. The difference-curve avoids this difficulty, and is much to be preferred for laboratory work. But for occasional reduction it is so easy to calculate the difference directly from the formula that it is not worth while to take the trouble to plot a curve.

Reduction of Olszewski's Observations.—The observations of Olszewski on the critical pressure and temperature and boiling-point of hydrogen, described in the *Phil. Mag.* for July 1895, were made with a platinum thermometer of $\cdot001$ inch wire wound on a mica frame in the usual manner. He graduated this thermometer by direct comparison with a constant-volume hydrogen thermometer at the lowest temperatures which he could obtain by means of liquid oxygen boiling under diminished pressure. The lower temperatures, observed with the thermometer immersed in temporarily liquefied hydrogen, were deduced from the observed resistances by *rectilinear* extrapolation, assuming that the resistance of the platinum thermometer continued to decrease, as the temperature fell, at the same rate as over the lowest temperature interval, $-182\cdot5$ to $-208\cdot5$, included in the range of the comparison with the hydrogen thermometer. It is possible that, at these low temperatures, the resistance of platinum does not continue to follow the usual formula, but it may be interesting to give a reduction of his observations by the difference method for the sake of uniformity of expression.

We select for this purpose the following data:—

Thermometer in Melting Ice,
 $R/R^{\circ} = 1.000, \quad t = 0^{\circ} \text{C.}$

Thermometer in solid CO_2 at 760 mm.,
 $R/R^{\circ} = .800, \quad t = -78.2^{\circ} \text{C.}$

Thermometer in Liquid O_2 at 760 mm.,
 $R/R^{\circ} = .523, \quad t = -182.5^{\circ} \text{C.}$

From these we deduce the following values of the coefficients:—

$$a = .002515, \quad b = -.000,000,53, \quad c = .002462, \quad d = 2.13, \\ pt^{\circ} = 406^{\circ}.2.$$

As a verification we have the observation $R/R^{\circ} = .453$, at $t = -208.5^{\circ} \text{C.}$ This gives $pt = -222.2$, $D = 13^{\circ}.7$, which agrees with the value given by the difference-formula calculated from the three higher points.

The following Table gives the reduction of the observations taken with this thermometer in partially liquid hydrogen.

TABLE III.—Reduction of Olszewski's Observations in Boiling Hydrogen.

Pressure.	R/R [°] Obs.	<i>pt</i> .	D.	<i>t</i> (° C.).	<i>t</i> Olszewski.	<i>t'</i> .
atmos.						
20	.383	-250.6	16.6	-234.0	-234.5	-233.4
10	.369	-256.3	17.3	-239.0	-239.7	-238.4
1	.359	-260.4	17.7	-242.7	-243.5	-242.0

The effect of this change in the method of reduction is to make the temperature of the boiling-point of hydrogen nearly one degree higher than the value given by Olszewski. If we employ instead the difference-formula in terms of *pt*, we should find $d' = .002472$, $pt^{\circ} = 404.5$, $d' = 1.85$. This formula leads to the values given in the column headed *t'*, which are a little higher.

The value found by Dewar for *liquid* hydrogen (Proc. R. S. Dec. 16, 1898) is much higher, namely $t = -238.8$ at one atmo, and -239.6^* at 1/30th atmo. The difference may possibly be due to the superheating of the liquid, or, more probably, to some singularity in the behaviour of his thermometer at this point (see below, p. 218).

Observations of Holborn and Wien (Wied. Ann. lix. 1896).—Holborn and Wien made a direct comparison between the

* Values calculated from observed resistances by formula (2). Dewar gave -238.4 , and -239.1 .

hydrogen and platinum thermometers, adopting my method of enclosing the spiral inside the bulb of the air-thermometer. The majority of their observations were taken while the temperature of the instrument was slowly rising. This method of procedure is very simple, but it is open to the objection that the mean temperature of the spiral is not necessarily the same as that of the gas enclosed, especially when, as in their apparatus, the spiral is asymmetrically situated in an asymmetrical bulb. If we take their observations in melting ice, in solid CO_2 , and in liquid air, which are probably in this respect the most reliable, and calculate a difference-formula in terms of pt , we shall find $c' = \cdot 003621$, $d' = 1\cdot 69$. Calculating the values of t' by this formula, we find that all the rest of their observations make the temperature of the platinum spiral on the average 1° higher than that of the gas. This might be expected, as the temperature was not steady, and the warmer gas would settle at the top of the bulb, the spiral itself being also a source of heat.

If we take their own formula, and calculate the equivalent difference-formula, we find $c' = \cdot 003610$, $d' = 1\cdot 79$. This agrees fairly well with the values found above, as they appear also to have attached greater weight to the observations in CO_2 and liquid air. But, if we take the formula calculated by Dickson (*Phil. Mag.* Dec. 1897), who attaches equal weight to all their observations, we find $c' = \cdot 003527$, $d' = 2\cdot 43$. The excessive difference in the values of the coefficients deduced by this assumption is an index of the inconsistency of the observations themselves*.

Behaviour of Pure Wire at Low Temperatures.—In the case of ordinary platinum wire, with a coefficient $c = \cdot 0035$ or less, the effect of the curvature at low temperatures of the t, R , curve, as represented by the positive value of the difference-coefficient d , is to make the resistance diminish more rapidly as the temperature falls, and tend to vanish at a point nearer to the absolute zero than the fundamental zero of the wire itself. When, however, the value of pt° is numerically less than 273° , the effect of this curvature would be to make the resistance vanish at some temperature higher than the absolute zero. If, therefore, we may assume that the resistance ought not to vanish before the absolute zero, we should expect to find a singular point, or a change in sign of the difference-coefficient, at low temperatures. If this were the case, it would seriously invalidate the difference-formula method of reduction, at least at low temperatures, and as

* Contrast the close agreement of Dickson's reduction in the case of Fleming's observations.

applied to wires for which pt° was numerically less than 273° . When, therefore, I succeeded in obtaining in 1892 a very pure specimen of wire, with the coefficient $c = \cdot 00389$, $pt^\circ = 257^\circ$, I quite expected to find it behave like iron and tin, with the opposite curvature to the impure platinum, and a *negative* value for the coefficient d . On testing it at the S.B.P. and also at the Ag.F.P. I found, on the contrary, that it gave a value $d = +1\cdot 50$, and that its scale agreed very closely with that of all the other platinum wires I had tested, at least at temperatures above 0° C. I sent a specimen to Prof. Fleming shortly afterwards and he used it as the "working thermometer P_2 " in his researches on the thermo-electric properties of metals at low temperatures. The test of this wire is given by Fleming in the *Phil. Mag.* July 1895, p. 101, from which the following details are extracted:—

$$c = \cdot 003885, pt^\circ = 257^\circ\cdot 4. \text{ CO}_2 \text{ B.P.}, pt = -81^\circ\cdot 3. \\ \text{O.B.P.}, pt = -193^\circ\cdot 3.$$

Assuming $t = -182^\circ\cdot 5$ at the O.B.P., we have $d = +2\cdot 10$, which gives $t = -78^\circ\cdot 4$ for the temperature of solid CO_2 . The value of the difference-coefficient, so far from vanishing or changing sign, appears to be actually greater at very low temperatures. According to this formula, the resistance of the wire tends to vanish at a temperature $t^\circ = -240^\circ\cdot 2$, corresponding to $pt^\circ = -257^\circ\cdot 4$. It seems not unlikely, however, according to the observations of Dewar, that the resistance, instead of completely vanishing at this temperature, which is close to the boiling-point of hydrogen, ceases to diminish rapidly just before reaching this point, and remains at a small but nearly constant value, about 2 per cent. of its value at 0° C.

Application of the Difference-Formula to the case of other Metals.—The application of the difference-formula is not limited to the case of platinum. It affords a very convenient method of reduction of observations on the resistance-variation of other metals. I employed it for this purpose in the comparison of platinum and iron wires*, as a means of verifying the suitability of the parabolic formula for the expression of variation of resistance with temperature. Thus, if the symbol ft stands for the temperature by an iron-wire thermometer, defined by formula (1), in exactly the same manner as the platinum temperature, and if d and d' stand for the difference-coefficients of platinum and iron respectively, assuming that both wires are at the same temperature t , we have clearly the relation

$$ft - pt = (d - d') \times p(t).$$

* *Phil. Trans. A.* 1887, p. 227.

As an illustration of the convenience of this method of reduction a table is appended giving the values of the constants at low temperatures for the specimens tested by Dewar and Fleming. The data assumed in each case are (1) the value of the fundamental coefficient c given in the first column, and (2) the value of the temperature of the O.B.P. on the scale of each particular metal, calculated from the observed resistance by formula (1), and given in the third column. The value of the difference-coefficient d° for each metal as deduced from the O.B.P. is found at once by the relation

$$d^\circ = (-pt - 182.5)/5.16.$$

The sign of this coefficient indicates the direction of the curvature of the temperature-resistance curve, and its magnitude is approximately proportional to the average relative curvature over the experimental range.

The values of the coefficients a and b , given in the last two columns, are readily calculated from those of c and d by means of the relations already given (p. 199). These coefficients refer to the equivalent resistance-formula (3), and are useful for calculating the specific resistance at any temperature.

In comparing the values of d° , given in this table, with those deduced from observations at higher temperatures, it will be noticed that they are in most cases algebraically greater, the difference amounting to nearly 30 per cent. in many cases between the values deduced from the O.B.P. and the S.B.P. respectively. It is possible that this indicates a general departure from the exact parabola requiring further experiments for its elucidation. It would be unsafe, however, to infer from the results of the present investigation that this is always the case, because, owing to the construction of the coils with silk and ebonite insulation, it was impossible to test the wires directly in sulphur, and they could not be annealed after winding at a higher temperature than 200° . It is well known that annealing produces a marked effect on the form of the curve and on the value of d^* . It is also stated in the paper that trouble was experienced from thermoelectric disturbances, owing to the use of thick copper leads 4 mm. in diameter. Such effects cannot be satisfactorily eliminated except by the employment of a special method of compensa-

* With reference to this point it is interesting to remark that Messrs. Heycock and Neville with one of their perfectly annealed pyrometers of pure wire, for which $c = .00387$, $d = 1.497$, found the value $pt = -80.3$, $t = -78.2^\circ\text{C}$., for the CO_2 B.P. This would perhaps indicate that the larger values of d were due to imperfect annealing.

TABLE IV.—Application of the Difference-Formula to other Metals.

Metal.	Fundamental Coefficient. <i>c</i> .	Fundamental Zero. <i>-pt.</i>	O.B.P. Observed. <i>pt.</i>	Difference-Coefficient. <i>d</i> ^o .	Vanishing Temperature. <i>t</i> ^o .	$(dR/dt)/R^o$ at 0° C. <i>a</i> × 10 ⁵ .	$\frac{(d^2R/dt^2)}{2R^o}$ <i>b</i> × 10 ⁵ .
Platinum (1).....	·003533	-283·0	-196·7	+2·75	-257·7	3600	-0·97
" (2).....	·003669	-272·5	-196·5	+2·72	-248·8	3769	-0·99
" (3).....	·003885	-257·4	-193·3	+2·10	-240·2	3967	-0·82
Gold	·00377	-265·2	-183·0	+0·10	-264·2	3774	-0·04
Palladium	·00354	-282·4	-205·5	+4·46	-244·7	3698	-1·58
Silver	·00400	-250·0	-183·5	+0·19	-248·4	4008	-0·08
Copper	·00428	-234·0	-190·2	+1·49	-223·2	4344	-0·64
Aluminium	·00435	-230·0	-186·4	+0·75	-224·5	4383	-0·33
" 99°/0.....	·00423	-236·0	-185·0	+0·29	-233·7	4242	-0·13
Iron (A).....	·00544	-184·0	-143·0	-7·68	-252·2	5014	+4·18
" (H.W.).....	·00625	-160·0	-138·5	-8·75	-223·7	5703	+5·47
Nickel (Mond)	·00622	-161·0	-135·8	-9·06	-228·5	5656	+5·63
Tin	·00440	-227·5	-168·2	-3·60	-261·3	4242	+1·58
Magnesium	·00381	-262·5	-202·0	+3·80	-232·0	3955	-1·45
Zinc	·00406	-276·7	-182·5	+0·00	-246·7	4060	+0·00
Cadmium	·00419	-238·7	-168·3	-3·57	-275·7	4040	+1·50
Lead	·00411	-244·0	-171·7	-2·10	-244·2	4014	+0·86
Thallium	·00398	-251·6	-181·3	-0·23	-253·6	3971	+0·09

tion, which will be described in a subsequent communication. The general result of any residual thermal effects which may be present is to produce a change in the apparent value of d , since the thermo-E.M.F. follows approximately a parabolic formula. It is possible, for this reason, to obtain consistent and accurate measurements of temperature with a platinum thermometer in spite of large thermal effects, but the value of d would be very considerably affected.

On the "Vanishing Temperature."—There appears to be a very general consensus of opinion, based chiefly on the particular series of experiments which are under discussion, that the resistance of all pure metals ought to vanish, and does tend to vanish at a temperature which is no other than the absolute zero. If, however, there is any virtue in the parabolic method of reduction, it is quite obvious, on reference to the column headed "Vanishing Temperature" in the above table, that the resistance "tends to vanish" in the case of most of the common metals at a much higher temperature. The vanishing temperature t° is the value of t deduced from the fundamental zero pt° in each case by means of the difference-formula, employing the value of d° given in the table. The most remarkable metals in this respect are pure copper and iron, which tend to become perfect conductors at a temperature of -223° approximately, a point which is now well within the experimental range. These are followed at a very short interval by aluminium, nickel, and magnesium. In the case of copper and iron special experiments were made at a temperature as low as -206° C., at which point the rate of decrease of resistance showed little, if any, sign of diminution. The exact value of the vanishing temperature in each case is necessarily somewhat uncertain owing to the necessity of extrapolation, and also on account of possible uncertainties in the data; but there can be no doubt that the conclusion derived from the formula represents, at least approximately, a genuine physical fact. Whether or no the resistance does actually vanish at some such temperature may well be open to doubt. It would require very accurate observations to determine such a point satisfactorily, as the experimental difficulties are considerable in measuring so small a resistance under such conditions. It is more probable that there is a singular point on the curve, similar to that occurring in the case of iron at the critical temperature, at which it ceases to be magnetic. It is also likely that the change would not be sudden, but gradual, and that indications of the approaching singularity would be obtained a few degrees above the point in question. Below this point it is even pos-

sible that the resistance might not tend to vanish, but, as in the case apparently of bismuth, might increase with further fall of temperature. It has been suggested that at very low temperatures all metals might become magnetic. It is very probable that the change of electrical structure here indicated would be accompanied by remarkable changes in the magnetic properties. These are some of the points which experiment will probably decide in the near future. The only experimental verification at present available is the observation of Dewar in the case of platinum No. 3 when immersed in boiling hydrogen at -240° C., that the resistance after attaining a very low value apparently refused to diminish further, in spite of a considerable lowering of the pressure. It would be extremely interesting to repeat this observation with specially constructed thermometers of copper or iron, which ought to show the effect in a more striking manner and at a higher temperature.

My thanks are due to Messrs. E. H. Griffiths, C. T. Heycock, and F. H. Neville, and to Prof. A. W. Porter and Mr. N. Eumorfopoulos, for their kind assistance in revising and correcting the proofs of this article.

XIV. *A Calorimetric Determination of Energy Dissipated in Condensers.* By EDWARD B. ROSA and ARTHUR W. SMITH*.

IN a former paper (*suprà*, p. 19) we gave the results of measurements by means of a wattmeter of the energy dissipated in condensers when they were subjected to an alternating electromotive force. The results were such that we desired to confirm them by a totally independent method: and, in addition, to measure the energy dissipated in some paraffined-paper condensers which showed so small a loss that with the coils at our disposal the Resonance Method, employed successfully on beeswax and rosin condensers, would not give sufficiently accurate values. We therefore constructed a special calorimeter for the purpose of measuring the total quantity of heat produced in the condensers, which represents the total energy dissipated.

Fig. 1 gives an external view of the calorimeter, and fig. 2 a vertical section. The calorimeter proper, A, is the inner of three concentric boxes, and is 33 cm. long, 30 cm. deep, and 10 cm. in breadth. It has a copper lining, *a*, and a copper jacket, *b*, and is protected by the two exterior boxes from fluctuations of temperature without. The general principle of the calorimeter is (1) to prevent any loss or gain of heat

* Communicated by the Authors.

through its walls, and (2) to carry away and measure all heat generated within by a stream of water. To effect the first condition two concentric copper walls (the lining and the jacket) are maintained as nearly as possible at the same temperature. This, of course, will reduce the flow of heat through the intervening wooden wall to a minimum, and make the "cooling correction" small, if not zero.

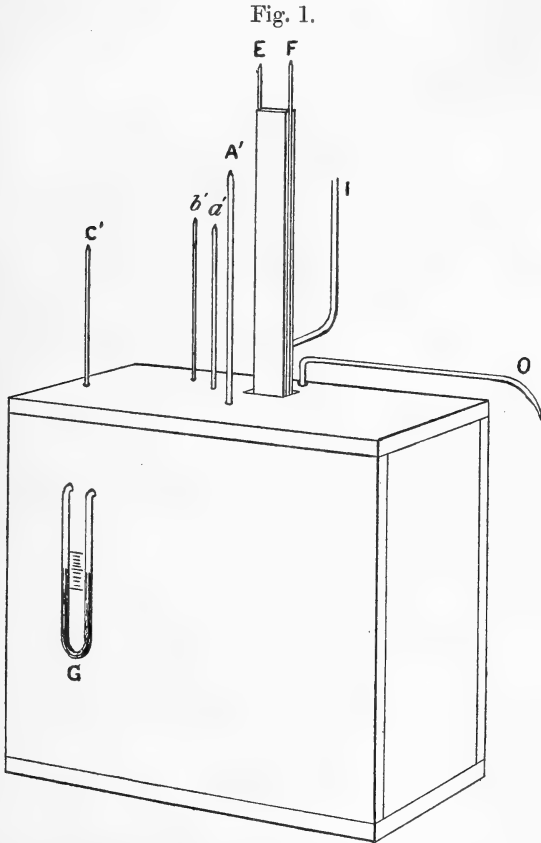

1. *To Eliminate the Cooling and Capacity Corrections.*

In order to ascertain any difference of temperature between the copper walls *a* and *b*, a differential air-thermometer is used. Each air-chamber of this differential thermometer consists of a copper pipe about 4 metres long and 4 millim. internal diameter, one coiled about and soldered to the lining,

and the other coiled about and soldered to the jacket. One end of each pipe is closed and the other connected to one end of the U-tube, G, shown on the outside of the calorimeter in fig. 1. The U-tube, which we call the gauge, contains kerosene oil, and serves to indicate any difference of temperature between the two copper walls. The zero-mark is fixed after

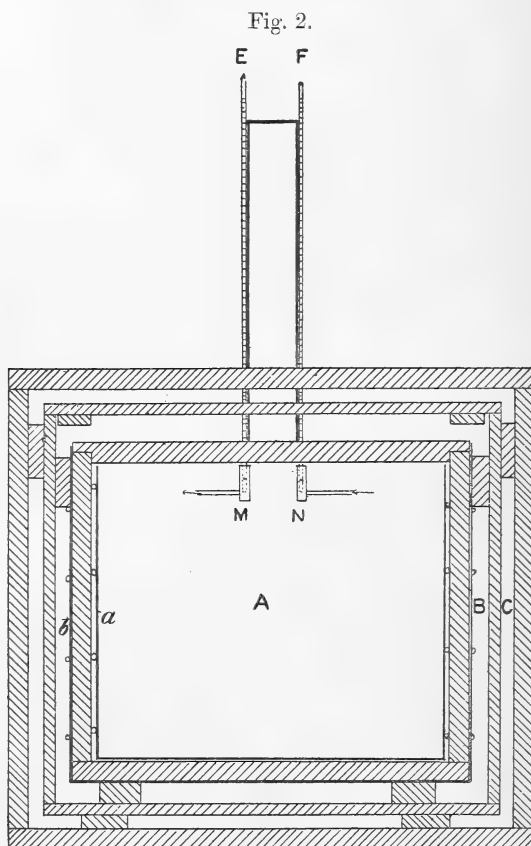

maintaining the whole calorimeter at a constant temperature for some hours. In order to keep the gauge reading sensibly zero, and thus keep the two copper walls very closely at the same temperature, a coil of wire through which an electric current of any desired strength can be passed is wound about the jacket in the space B. And in order to make the regulation more perfect a second coil is wound about the second box in

the space C, so as to maintain the temperature of this space nearly constant. The temperature of the chamber A is usually kept a little higher than the external temperature, so that no cooling is required; and by varying the currents in the two heating-coils the temperature in B can be made to follow that in A so closely that the gauge-readings are always small, and their algebraic sum during any experiment zero. This eliminates all correction for radiation. In rare cases when the temperature of the room has risen considerably, we have found it necessary to hang a wet cloth about the box to prevent the temperature of C rising above that of B and A. We intend to coil a small copper pipe in C so that a stream of cool water may be sent through it, and then no difficulty will be encountered in the hottest weather.

In addition to the gauge four thermometers (fig. 1) indicate the temperatures of A, *a*, *b*, and C: that is, A' shows the temperature of the air in the calorimeter chamber A; *a'* has its bulb in a pocket of the lining *a*, and hence indicates the temperature of the wall *a*; *b'* similarly extends down into a pocket of the copper jacket *b*, and shows its temperature. Finally, C' gives the temperature of the outer air-space C. A' is an accurate thermometer reading from $\pm 0^{\circ}$ to 25° C., graduated to $0^{\circ}\cdot 01$ and read to $0^{\circ}\cdot 001$ C. If A' shows the temperature to be constant during the whole period of an experiment, or the same for a considerable time near the end of an experiment that it was at the beginning, then there will be no correction for heat absorbed or given up by the apparatus. With both the "cooling correction" and the capacity correction eliminated, it remains to carry away and measure the entire heat generated by a condenser in A, or by any other source of heat within the calorimeter.

2. *Carrying away and Measuring the Heat.*

In order to carry away the heat generated a stream of water, which enters at I (figs. 1 and 3), is made to flow through a coiled copper pipe (fig. 3), where it absorbs heat, and then leaves the calorimeter at O. In order to increase its absorbing capacity the pipe is soldered to a sheet of copper, L L, both pipe and copper being painted black. Three such sheets, each with 4 metres of pipe attached, are joined together and placed side by side in the chamber A, the condensers being slipped in between them. The rate of absorption of heat depends upon the difference of temperature between the absorbers and the air surrounding them. If a large

amount of heat is to be brought away, the water is made to enter at a low temperature and to flow rapidly through the absorbers. If a smaller quantity of heat is to be absorbed and carried away, the entering water will be warmer, and its gain in temperature correspondingly less. By varying the temperature of the water and its rate of flow, the rate of absorption can be varied between wide limits, and kept very

Fig. 3.

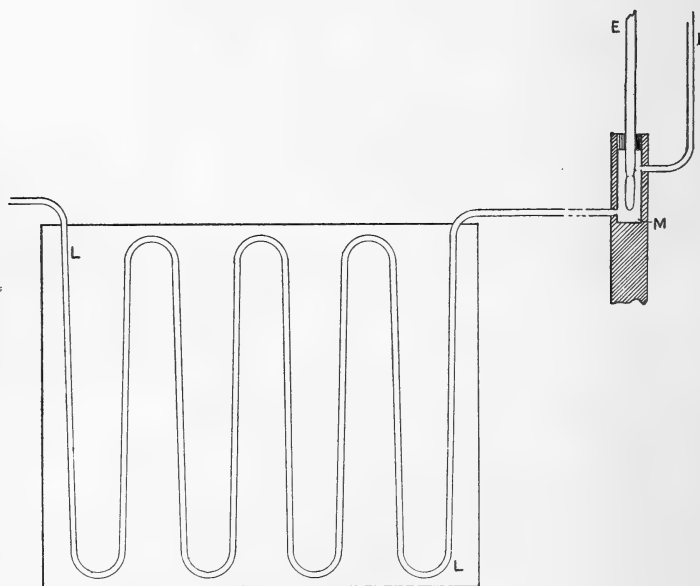

nicely at any desired point. In practice the thermometer A' is the guide in regulating the temperature of the entering water. If the temperature of A begins to rise (A' , as already stated, can be read to one-thousandth of a degree), the entering water is slightly cooled; if to fall, it is slightly warmed; the rate of flow of water, after being once adjusted for a given experiment, is maintained constant.

In order to measure the quantity of heat thus carried away, the thermometers E and F are inserted in two small reservoirs, M and N , which stand in the wooden wall of the calorimeter between the two copper surfaces. The thermometer E indicates the temperature of the water just as it enters the chamber A , and the thermometer F gives its temperature as it leaves. The difference of temperature multiplied

by the mass of water per second gives the rate of absorption and removal of heat. The thermometers are accurately graduated and read to hundredths of a degree. The gain in temperature is several degrees, and may be ten or twenty degrees by increasing the quantity of heat generated or reducing the rate of flow of water. Hence the accuracy of the determination of the quantity of heat absorbed is sufficient for most purposes. The chief error is ordinarily due to changes in the temperature of the apparatus itself and its contents. By running the experiment several hours, however, and keeping it as nearly as possible at a constant temperature, this uncertainty is greatly reduced and the error made negligibly small.

The water flows into the calorimeter from a reservoir about a metre above, this height furnishing the necessary pressure. The temperature of the entering water is regulated by adding warm or cold water to the reservoir, and the rate of flow of the water is regulated by an adjustable valve. The water is collected in a litre flask, the time of each litre being recorded.

3. *Test of the Calorimeter.*

Table I. shows the result of one of the tests made upon the calorimeter. A current of electricity passed through a coil of wire within the chamber A, the electromotive force being measured by a carefully calibrated Weston voltmeter, and the current by a Kelvin balance. The experiment continued for a little more than four hours, while nine litres of water passed through the calorimeter. The rate of absorption of heat was nearly, but not quite, constant, the temperature as indicated by A' having varied slightly. The final temperature was practically the same as that at the beginning, being slightly higher if anything. The average for the nine litres is 12·37 watts absorbed and carried away by the water, while the electrical measurements give 12·34 watts. By continuing the experiment longer and introducing greater refinements in the measurement of the current and electromotive force, a greater degree of accuracy could undoubtedly be attained. But this and other tests showed clearly that for our present purposes the calorimeter was abundantly accurate, and we proceeded to put some condensers into it and measure the heat evolved.

TABLE I.
Test of the Calorimeter.

(b) Time.	(c) Period in seconds for each 1000grm. of water.	(d) Average temperature of the ingoing water.	(e) Average temperature of the outgoing water.	(f) Increase in temperature of each 1000grm. of water. (e) - (d).	(g) Total heat measured (small calories). (f) × 1000.	(h) Small calories per second. (g) ÷ (c).	(i) Equivalent watts = calories × J. (h) × 4·1972.
h. m. s.							
1 53 00							
2 19 45	1605	15·66	20·39	4·73	4730	2·947	12·37
2 46 50	1625	15·70	20·44	4·74	4740	2·917	12·24
3 13 55	1625	15·74	20·51	4·77	4770	2·935	12·32
3 41 15	1640	15·70	20·53	4·83	4830	2·945	12·36
4 09 10	1675	15·72	20·64	4·92	4920	2·937	12·33
4 37 10	1680	15·57	20·56	4·99	4990	2·970	12·47
5 04 10	1620	15·64	20·58	4·94	4940	3·050	12·79
5 32 15	1685	15·55	20·50	4·95	4950	2·950	12·33
6 01 00	1725	15·57	20·56	4·99	4990	2·893	12·14
							12·37

Electromotive force = 20·0 volts.

Current = 0·617 ampere.

Watts (from electrical measurements) = 20·0 × 0·617 = 12·34.

4. The Experiments.

Table II. (p. 230) gives the results of six experiments with the same beeswax and rosin condensers which were employed in our work by the resonance method. In each experiment a preliminary run, not included in the table, allows the condensers and calorimeter to come to a constant temperature. Column (a) gives the numbers of the condensers in each case, they all being joined in parallel to the same electromotive force. Column (b) gives the time of the beginning of each litre of water; column (c) the duration of each litre or 1000 grammes of water; column (d) the average temperature of the ingoing water as found from readings of the thermometer E, taken regularly every five minutes, and column (e) the same for the outgoing water; (f) then shows the increase of temperature. Column (g) gives the number of calories of heat carried away by each 1000 grammes of water, and column (h), which is the number in (g) divided by the corresponding number of seconds recorded in (c), is the rate of absorption of heat. Column (i) gives the number of watts to which this is equivalent, taking

J, the mechanical equivalent of heat, to be 41,972,000 ergs. This is the value derived from Rowland's and Griffiths's work, assuming the specific heat of water at an average temperature of 20° C. to be unity. Column (*j*) gives the frequency. Sometimes this was estimated from the average frequency of the dynamo supplying the lines of the Middletown lighting-circuits at the time; and in other cases it was determined by measuring the speed of a small synchronous motor. The electromotive force (*k*) was measured with an electrometer, the current (*l*) with a Siemens dynamometer. Column (*n*) gives the values of $\cos \phi$ of the expression power = $EI \cos \phi$. Care was taken in every instance to avoid the presence of upper harmonics, in some cases using a resonance-coil to quench the harmonics as well as increase the voltage on the condenser. Column (*o*) gives the per cent. loss, $100\pi \cot \phi$, and column (*p*) the net efficiency. This relative loss, $\pi \cot \phi$, has been proved* to be the ratio of *w* to *W*, where *w* is the energy dissipated per half-period, and *W* is the energy stored in the condenser at each charge. $1 - \pi \cot \phi$, the net efficiency, is therefore

$$\frac{\text{Energy stored} - \text{Energy lost}}{\text{Energy stored}}$$

5. *Beeswax and Rosin Condensers.*

The first experiment, with condensers Nos. 3, 4, and 7, showed a net efficiency of 93.39 per cent., or a loss of 6.61 per cent. The temperature of the condensers was not determined; but from the fact that the dielectric was softened and the quantity of heat generated was more than in any succeeding experiment, we feel sure that it was considerably above 40° C. Six condensers were then placed in the calorimeter, joined in three pairs. Nos. 1 and 5 gave no sound when joined to an alternating E.M.F. of 1000 or more volts, and we called it the "best pair." In Nos. 3 and 4 vibrations were distinctly felt when the fingers were placed in contact with them, while the condensers gave a clear musical note and on the higher voltages a hissing sound; this we called the "poorest pair." Nos. 8 and 9 were intermediate.

These six condensers were first of all joined in parallel and connected to a low-frequency circuit of 1520 volts and 26 periods per second. Care was taken to exclude upper harmonics. The experiment continued over three hours after the temperature of calorimeter and condensers had become

* See our paper, *Phil. Mag.* Jan. 1899.

TABLE II.—Measurements of Energy dissipated

(a)	(b)	(c)	(d)	(e)	(f)	(g)	(h)
No. of the condenser.	Time.	Period in seconds for each 1000 grams of water.	Average temperature of the ingoing water.	Average temperature of the outgoing water.	Increase in temperature of each 1000 grams of water. (e)−(d).	Total heat measured (small calories). (f)×1000.	Small calories per second. (g)÷(c).
(1)	h m s						
	9 36 00						
3, 4, & 7.	10 02 00	1560	15.76	20.84	5.08	5080	3.256
	10 25 00	1380	15.76	20.72	4.96	4960	3.595
	10 51 30	1590	15.87	20.14	4.27	4270	2.686
(2)	6 34 35						
	7 12 30	2275	17.78	22.07	4.29	4290	1.886
1 & 5,	7 49 15	2205	17.57	22.08	4.51	4510	2.045
3 & 4,	8 26 30	2235	16.94	22.08	5.14	5140	2.300
8 & 9.	9 05 10	2320	16.59	21.97	5.38	5380	2.319
	9 41 40	2190	16.23	21.92	5.69	5690	2.598
(3)	2 56 30						
	3 27 10	1840	17.62	21.60	3.98	3980	2.163
1 & 5,	3 55 45	1715	17.71	21.54	3.83	3830	2.233
3 & 4,	4 24 00	1695	17.61	21.48	3.87	3870	2.283
8 & 9.	4 52 15	1695	17.66	21.45	3.79	3790	2.236
	5 21 20	1745	17.58	21.43	3.85	3850	2.206
(4)	7 10 40						
	7 28 13	1653	17.65	21.58	3.93	3930	2.378
	7 56 40	1707	17.71	21.62	3.91	3910	2.291
1 & 5.	8 25 47	1747	17.70	21.66	3.96	3960	2.267
	8 55 50	1803	17.68	21.69	4.01	4010	2.228
	9 26 20	1830	17.63	21.66	4.03	4030	2.202
(5)	2 38 30						
	3 11 30	1980	20.64	22.65	2.01	2010	1.015
1 & 5.	3 44 20	1970	20.90	22.62	2.02	2020	1.025
	4 17 20	1980	20.66	22.58	2.02	2020	1.020
	4 50 20	1980	20.68	22.64	1.96	1960	0.990
(6)	8 37 20						
	9 15 20	2280	20.55	22.27	1.72	1720	0.754
3 & 4.	9 54 15	2335	20.59	22.28	1.69	1690	0.724

in Beeswax and Rosin Condensers.

(i) Equivalent watts = average calories \times J. (h) \times 4.1972.	(j) Fre- quency.	(k) Electro- motive force (volts). E.	(l) Current (amperes). I.	(m) Apparent watts. E \times I.	(n) cos ϕ . (i) \div (m).	(o) Per cent loss = $\pi \cot \phi \times 100$. (n) \times $\pi \times 100$.	(p) Efficiency = (1 - $\pi \cot \phi$) \times 100. 100 - (o).
13.34	140	868	.730	634	.0210	6.61	93.39 (30°)
9.36	26	1520	.400	608	.0154	4.84	95.16 (30°)
9.33	120	650	.897	583	.0160	5.06	94.94 (40°)
9.54	140	805	.445	358	.0266	8.37	91.63 (30°)
4.25	137	630	.333	210	.0202	6.35	93.65 (30°)
3.10	140	605	.333	202	.0154	4.82	95.18

constant by a preliminary run of several hours. The temperature of the calorimeter as indicated by the thermometer A' rose gradually for an hour, and hence the heat absorbed was less than the average. During the last hour the temperature was reduced by quickening the rate of flow and cooling the entering water, so that the temperature was substantially the same at the end as at the beginning. The per cent. of loss is 4.84 at an average temperature of the condensers of 30° C. The voltage employed on this low-frequency test was much higher than for any other experiment, and yet there was no evidence of brush-discharge or appreciable leakage-current.

In the third experiment the same condensers were subjected to a high-frequency electromotive force at 30° C., and the loss found to be 5.06 per cent., that is, slightly greater than before. Hence for a given voltage the energy dissipated *per period* would be slightly greater, and the energy dissipated *per second* more than five times as much as for the low frequency.

In the fourth experiment only the "best pair" of condensers was used, and with a slightly higher voltage the temperature of the condensers rose to 40° C. Here the loss was found to be 8.37 per cent., nearly as much as the maximum value found by the resonance method.

The fifth experiment, with the "best pair," was made some days later at 30° C., and the percentage loss came out 6.35 per cent., that is *greater* than the average of the six. This was unexpected, as well as the last result, which showed a loss for condensers 3 and 4, the "poorest pair," of 4.82 per cent., which was *less* than the average. These results were then confirmed by an independent method, showing conclusively that the so-called "poorest pair" had the smallest loss; not, of course, *because* it emitted a distinct sound and hissed on high voltages, but in spite of that. The chief loss is doubtless due to some cause quite independent of the singing and hissing, and happens to be smaller where it would naturally be expected to be larger.

Thus we have confirmed by these calorimetric measurements the large values of the losses which we found by the resonance method in beeswax and rosin condensers, and also the existence of a well-marked maximum as the temperature rises, beyond which the loss decreases considerably. It is an interesting fact that the residual charges of these condensers are very large, that they increase with the temperature up to 40° C., and then decrease as the temperature is carried higher. That is, *the maximum point for the residual charge is the same as for the energy loss.*

6. *Paraffined-Paper Condensers.*

The second lot of condensers used were commercial paraffined-paper condensers made by the Stanley Electric Co. A finished condenser is a solid slab about 25×30 cm. and 2 cm. thick, thus having a volume of 1500 c. c., and is enclosed in a tight tin case, the lead-wires coming out through ebonite bushings. Nos. 1 to 4 of our condensers have a capacity of about 1.7 microfarad each; Nos. 5 to 10, which were purchased about a year later, have a capacity of about 3.2 microfarads each. The condensers of the second lot are made of paper about .0038 cm. thick, two sheets being placed together in each stratum. This we learned by dissecting some which we had broken down. It ought to be stated, however, that while the condensers are guaranteed by the makers to stand 500 volts alternating electromotive force, we have repeatedly subjected them to 1000 to 2000 volts, and in some cases for several hours at a time. Nos. 9 and 10 were upon one occasion maintained at 2250 (effective) volts, at a frequency of 130, for over an hour, and showed no signs of being over-taxed. We have, however, broken several at voltages between 1000 and 2000. The paper of the first lot of condensers is thicker, but as we have never broken one of this lot we cannot state its thickness. From the fact that the capacity of each of these is about 60 per cent. as great as that of the others, while their volumes are substantially the same, we conclude that the thickness of the paper is about .0048 cm., supposing there are, as in the other, two sheets together in every stratum of the condensers.

In Table III. are given the results of seven separate experiments with Stanley condensers, which were made at intervals during the past three months. The frequency in every case except experiment 4 was estimated from the average frequency of the two dynamos of the Middletown lighting circuits. Experiments 1 and 3 were made when the faster dynamo was supplying the lines, the others were with the slower dynamo. All but No. 4, however, were with a relatively high frequency. No. 4 was made using a two-pole rotary transformer, supplying it with direct current, and running it at a speed of 1600 per minute. The percentage losses (ϕ) vary more among the different condensers at the same frequency than one would expect.

The percentage loss at the frequency 28 (Experiment 4) is .78 per cent., whereas at a frequency five times as great it is (Experiment 3) 1.00 per cent. At 120 it is, as would be expected, nearly as great as at 140; that is, it is .96 per cent.

TABLE III.—Measurements of Energy

(a)	(b)	(c)	(d)	(e)	(f)	(g)	(h)
No. of the condenser.	Time.	Period in seconds for each 1000 grams of water.	Average temperature of the ingoing water.	Average temperature of the outgoing water.	Increase in temperature of each 1000 grams of water. (e) - (d).	Total heat measured (small calories). (f) × 1000.	Small calories per second (g) ÷ (c).
(1)	h m s						
1.	7 24 00		19 ^o ·71	24 ^o ·12	4·41	4410	2·057
	7 59 50	2150	19·81	24·11	4·30	4300	1·955
	8 36 30	2200	19·82	24·20	4·38	4380	1·973
	9 13 30	2220					
(2)	12 33 25						
3 & 4.	1 04 00	1835	18 06	23 30	5·24	5240	2·856
	1 36 00	1920	18 04	23·43	5·39	5390	2·808
	2 07 40	1900	17·93	23·40	5·47	5470	2·879
	2 40 00	1940	17·98	23·47	5·49	5490	2·830
(3)	7 17 20						
3 & 4.	7 46 20	1740	16·71	22·09	5·38	5380	3·092
	8 15 50	1770	16·59	22·12	5·53	5530	3·124
	8 45 23	1773	16·33	22·11	5·78	5780	3·260
	9 14 43	1760	16·55	22·06	5·51	5510	3·131
(4)	12 21 12						
3 & 4.	1 21 25	3613*	18·45	22·46	4·01	2807*	0·777
	2 37 30	4565	18·67	22·47	3·80	3800	0·832
	3 47 35	4205	18·80	22·46	3·66	3660	0·870
(5)	12 24 20						
6.	12 55 10	1850	19·44	23·25	3·78	3786	2·140
	1 26 45	1895	19·55	23·20	3·65	3650	1·926
	1 59 30	1965	19·48	23·20	3·72	3720	1·893
(6)	6 05 08						
10.	6 41 30	2182	17 82	22·48	4·66	4660	2·136
	6 54 30	780†	18·10	22·80	4·70	1739†	2·231
(7)	2 17 55						
10.	2 50 00	1925	17·96	22·35	4 39	4390	2·281
	3 21 30	1890	18·05	22·39	4·34	4340	2·296
	3 53 28	1918	17·98	22·44	4·46	4460	2·325
	4 25 00	1952	17·92	22·44	4·52	4520	2·315

* The amount of water for this period was 700 grams.

† " " " 370 "

dissipated in Stanley Paraffin Condensers.

(i) Equivalent watts =average calories \times J (h) \times 4.1972.	(j) Fre- quency.	(k) Electro- motive force in volts. E.	(l) Current in amperes. I.	(m) Apparent watts. EI.	(n) $\cos \phi$ $(i) \div (m)$.	(o) Per cent. loss = $\pi \cot \phi \times 100$. $(n) \times \pi \times 100$.	(p) Efficiency = $(1 - \pi \cot \phi) \times 100$. 100 - (o).
8.36	140	1133	1.60	1813	.0046	1.45	98.55
11.93	120	1264	3.1	3918	.0030	.96	99.04
13.23	140	1194	3.5	4179	.0032	1.00	99.00
3.47	28	1659	.837	1389	.0025	.78	99.22
8.34	120	778	2.34	1822	.0046	1.44	98.56
9.17	120	1294	3.0	3882	.0024	.74	99.26
9.67	120	1294	3.0	3882	.0025	.78	99.22

(Experiment 2). Condenser No. 1, of the same lot, shows a loss of 1.45 per cent. at frequency 140, which is 45 per cent. greater loss than Nos. 3 and 4 give. Of the second lot, No. 6 gives a large loss (Experiment 5), and other experiments which one of us has made by other methods show that all the other condensers of this lot have losses nearly the same as No. 6, excepting No. 10, which gives the smallest loss of any, .74 per cent. in one case and .78 per cent. in another (Experiments 6 and 7). Condenser No. 2 shows by other methods the same loss as 3 and 4. Hence we have the following singular results:—*All of the first lot except one have a loss of 10 per cent. on high frequencies, and the exceptional condenser has a loss of 1.45 per cent. All the condensers of the second lot have substantially the same losses, about 1.5 per cent., and the exceptional one is scarcely more than one half as much as the others; the exceptional one of the first lot having the same loss as all but one of the second.* There is no possibility of a confusion of numbers, for they were plainly stamped when purchased, and the capacities of the first and second lots are very different, as already stated. Our experiments do not indicate the reason for these large differences; but the existence of such differences is fully confirmed by measurements made by wholly independent methods, and which will shortly be published.

Wesleyan University,
Middletown, Conn., Sept. 1, 1898.

XV. *On certain Properties of the Hypergeometrical Series, and on the fitting of such Series to Observation Polygons in the Theory of Chance.* By KARL PEARSON, F.R.S., University College, London*.

1. **I**N a paper entitled "Mathematical Contributions to the Theory of Evolution: Part II. Skew Variation in Homogeneous Material" †, I have pointed out that the following series, of which the skew-binomial is a special case ($n = \infty$),

$$\frac{pn(pn-1)(pn-2)\dots(pn-r+1)}{n(n-1)(n-2)\dots(n-r+1)} \times$$

$$\left(1 + r \frac{qn}{pn-r+1} + \frac{r(r-1)}{1.2} \frac{qn(qn-1)}{(pn-r+1)(pn-r+2)} \right.$$

$$\left. + \frac{r(r-1)(r-2)}{1.2.3} \frac{qn(qn-1)(qn-2)}{(pn-r+1)(pn-r+2)(pn-r+3)} + \&c. \right)$$

* Communicated by the Author.

† Phil. Trans. vol. clxxxvi. p. 360 (1895).

is especially adapted for fitting various types of frequency-distribution. The relative magnitude of r and n is, indeed, often a very good test of the "interdependence of contributory causes."

If we put

$$\alpha = -r, \beta = -qn, \gamma = pn - r + 1 \quad \dots \quad (2)$$

and denote by $F(\alpha, \beta, \gamma, x)$ the general hypergeometrical series

$$1 + \frac{\alpha \cdot \beta}{1 \cdot \gamma} x + \frac{\alpha(\alpha+1)\beta(\beta+1)}{1 \cdot 2 \cdot \gamma(\gamma+1)} x^2 + \&c. \quad \dots \quad (3)$$

we see that our series is a hypergeometrical series of the type $F(\alpha, \beta, \gamma, 1)$, or, as we shall denote it $F_1(\alpha, \beta, \gamma)$, multiplied by a factor, which we may write Δ .

If the successive terms of a hypergeometrical series be plotted up as ordinates at intervals c , and the tops of these ordinates be joined, we obtain a great variety of polygons, which approximate to the interesting series of generalized probability-curves with which I have already dealt. The advantage of the hypergeometrical polygons over the curves consists in the knowledge as to the nature of the chance distribution indicated by the discovery of the actual values of p, q, n , and r . The curves, however, possess continuity and are easier of calculation. Clearly a knowledge of α, β, γ , since $\gamma - \alpha - \beta - 1 = n$, gives n , and hence q, r , and p .

We shall find it convenient to write

$$m_1 = \alpha + \beta, \quad m_2 = \alpha\beta. \quad \dots \quad (4)$$

It is not, however, only in the question of distribution of frequency that hypergeometrical series may be of service; it seems extremely probable that the three constants α, β, γ of $F_1(\alpha, \beta, \gamma)$ may be of service in indicating close empirical approximations to physical laws, owing to the great variety of forms that the hypergeometrical polygon can take.

Before we proceed to the fitting of hypergeometrical polygons to given data, we require to demonstrate one or two general propositions with regard to such figures.

2. *On the moments of $F_1(\alpha, \beta, \gamma)$.*—Let A = the area of the polygon, thus if the ordinates are plotted at distance c , we have $A = c \times F_1$. Let $\mu_s A$ be the s th moment of the polygon about its centroid-vertical, the elements of area of the polygon being concentrated along the ordinates. Let $\nu_s A$ be the s th moment of the ordinates about a vertical parallel and at a distance c from the first ordinate, i.e.

$$\nu_s A = c \left\{ c^s + \frac{\alpha \cdot \beta}{1 \cdot \gamma} (2c)^s + \frac{\alpha(\alpha+1)\beta(\beta+1)}{1 \cdot 2 \cdot \gamma(\gamma+1)} (3c)^s + \&c. \right\} \quad (5)$$

Now let a new series of functions $\chi_0, \chi_1, \chi_2, \&c.$ be formed, so that

$$\chi_s = \frac{d}{dx}(x \chi_{s-1}),$$

and let $\chi_0 = F(\alpha, \beta, \gamma, x)$.

Then we have

$$\begin{aligned} \nu_s F_1 &= c^s (\chi_s)_{x=1}, \text{ or} \\ \nu_s &= c^s \times (\chi_s / \chi_0)_{x=1}. \end{aligned}$$

μ_s can then be found from $\nu_s, \nu_{s-1}, \nu_{s-2}, \&c.$ by the formulæ given on p. 77 of my memoir (Phil. Trans. vol. clxxxv.).

Thus the determination of the successive moments of the hypergeometrical series F_1 is thrown back on the discovery of the χ 's from the value F .

3. To find the successive χ 's.—The hypergeometrical series is known to satisfy the differential equation

$$(1-x)x \frac{d}{dx} \left(x \frac{dF}{dx} \right) + (n + (1-x)m_1)x \frac{dF}{dx} - m_2 x F = 0$$

(see Forsyth, 'Differential Equations,' p. 185).

But

$$\begin{aligned} x \frac{dF}{dx} &= \chi_1 - \chi_0, \\ x^2 \frac{d^2F}{dx^2} &= \chi_2 - 3\chi_1 + 2\chi_0. \end{aligned}$$

Hence, substituting and rearranging, we have

$$(1-x)\{\chi_2 + (m_1 - 2)\chi_1 + (m_2 - m_1 + 1)\chi_0\} + n\chi_1 - (n + m_2)\chi_0 = 0. \quad (6)$$

Put $x=1$, we have

$$(\chi_1)_1 = \frac{n + m_2}{n} (\chi_0)_1 \quad . \quad . \quad . \quad . \quad (7)$$

or

$$\nu_1 = c \frac{n + m_2}{n} \quad . \quad . \quad . \quad . \quad (8)$$

This is the distance of the centroid-vertical of the hypergeometrical series F_1 from the vertical about which the ν -moments are taken.

Multiply (6) by x and differentiate, we find

$$(1-x)\{\chi_3 + (m_1 - 2)\chi_2 + (m_2 - m_1 + 1)\chi_0\} - x\{\chi_2 + (m_1 - 2)\chi_1 + (m_2 - m_1 + 1)\chi_0\} + n\chi_2 - (n + m_2)\chi_1 = 0,$$

or

$$(1-x)\{\chi_3 + (m_1 - 1)\chi_2 + (m_2 - 1)\chi_1 + (m_2 - m_1 + 1)\chi_0\} + (n - 1)\chi_2 - (n + m_1 + m_2 - 2)\chi_1 - (m_2 - m_1 + 1)\chi_0 = 0 \quad . \quad (9)$$

Put $x=1$, we have

$$\begin{aligned} (n-1)(\chi_2)_1 &= (n+m_1+m_2-2)\chi_1 + (m_2-m_1+1)(\chi_0)_1 \\ &= (\chi_0)_1 \frac{n^2+n(3m_2-1)+m_2^2+m_1m_2-2m_2}{n}, \end{aligned} \quad (10)$$

by aid of (7).

Thus

$$\nu_2 = c^2 \frac{n^2+n(3m_2-1)+m_2^2+m_1m_2-2m_2}{n(n-1)} \quad (11)$$

and

$$\begin{aligned} \mu_2 &= \nu_2 - \nu_1^2 \\ &= c^2 \frac{m_2(n^2+m_1n+m_2)}{n^2(n-1)}; \end{aligned} \quad (12)$$

or, we may write

$$\mu_2 = \frac{c^2 \alpha \beta (n+\alpha)(n+\beta)}{n^2(n-1)} \quad (13)$$

Multiplying (9) by x and differentiating again, we find

$$\begin{aligned} (1-x)\{\chi_4+m_1\chi_3+(m_1+m_2-2)\chi_2+(2m_2-m_1)\chi_1+(m_2-m_1+1)\chi_0\} \\ + (n-2)\chi_3 - (n+2m_1+m_2-3)\chi_2 - (2m_2-m_1)\chi_1 - (m_2-m_1+1)\chi_0 = 0. \end{aligned} \quad (14)$$

Putting $x=1$, we have

$$\begin{aligned} (n-2)(\chi_3)_1 &= (n+2m_1+m_2-3)(\chi_2)_1 + (2m_2-m_1)(\chi_1)_1 \\ &\quad + (m_2-m_1+1)(\chi_0)_1, \end{aligned}$$

or, by aid of (7) and (10),

$$\begin{aligned} \nu_3 &= c^3 \{n^3+n^2(7m_2-3)+n(6m_2^2+6m_1m_2-15m_2+2)+m_2^3 \\ &\quad + 3m_1m_2^2+2m_1^2m_2-7m_2^2-6m_1m_2+6m_2\} \div n(n-1)(n-2). \end{aligned} \quad (15)$$

Hence, since $\mu_3 = \nu_3 - 3\nu_1\mu_2 - \nu_1^3$, we have after some reductions

$$\mu_3 = \frac{c^3 \alpha \beta (n+\alpha)(n+\beta)(n+2\alpha)(n+2\beta)}{n^3(n-1)(n-2)} \quad (16)$$

Differentiating (14) after multiplication by x , we find

$$\begin{aligned} (1-x)\{\chi_5+(m_1+1)\chi_4+(2m_1+m_2-2)\chi_3+(3m_2-2)\chi_2 \\ + (3m_2-2m_1+1)\chi_1+(m_2-m_1+1)\chi_0\} + (n-3)\chi_4 \\ - (n+3m_1+m_2-3)\chi_3 - (3m_2-2)\chi_2 - (3m_2-2m_1+1)\chi_1 \\ - (m_2-m_1+1)\chi_0 = 0. \end{aligned} \quad (17)$$

Putting $x=1$, we have

$$\begin{aligned} (n-3)(\chi_4)_1 &= (n+3m_1+m_2-3)(\chi_3)_1 + (3m_2-2)(\chi_2)_1 \\ &\quad + (3m_2-2m_1+1)(\chi_1)_1 + (m_2-m_1+1)(\chi_0)_1. \end{aligned}$$

Hence, by the use of (7), (10), and (15), we deduce

$$\begin{aligned} v_4 = & c^4 \{ n^4 + n^3(15m_2 - 6) + n^2(25m_2^2 + 25m_1m_2 - 65m_2 + 11) \\ & + n(10m_2^3 + 30m_1m_2^2 + 20m_1^2m_2 - 75m_2^2 - 65m_1m_2 + 80m_2 - 6) \\ & + m_2^4 + 6m_1m_2^3 + 11m_1^2m_2^2 + 6m_1^3m_2 - 16m_2^3 - 42m_1m_2^2 \\ & - 24m_1^2m_2 + 36m_1m_2 + 49m_2^2 - 24m_2 \} \\ & \div n(n-1)(n-2)(n-3). \dots \dots \dots (18) \end{aligned}$$

But

$$\mu_4 = v_4 - 4v_1\mu_3 - 6v_1^2\mu_2 - v_1^4;$$

thus we find

$$\begin{aligned} \mu_4 = & \frac{c^4 m_2 (n^2 + m_1 n + m_2)}{n^4 (n-1)(n-2)(n-3)} \times \{ n^4 + n^3(3m_2 + 6m_1 + 1) \\ & + n^2(3m_1m_2 + 6m_1^2 + 6m_2) + n(3m_2^2 + 18m_1m_2) + 18m_2^2 \}. \end{aligned} \quad (19)$$

Now

$$\alpha = -r, \quad \beta = -qn;$$

$$\therefore \frac{m_1}{n} = -\left(q + \frac{r}{n}\right), \quad \frac{m_2}{n} = rq.$$

Substitute these values in (19), and make n infinite. The hypergeometrical series now becomes the binomial $(p+q)^r$, and we have

$$\mu_4 = c^4(1 + 3(r-2)pq),$$

a result already deduced (Phil. Trans. vol. clxxxvi. p. 347). This serves to confirm (19).

Dividing equation (19) by $(1-x)$, and putting $x=1$, we find, by remembering that

$$\left(\frac{\chi_s}{1-x}\right)_{x=1} = \left(\frac{x\chi_s}{x(1-x)}\right)_{x=1} = \left\{ \frac{d(x\chi_s)}{dx} \right\}_{x=1} = -\{\chi_{s+1}\}_1,$$

$$\begin{aligned} (n-4)(\chi_5)_1 = & (n+4m_1+m_2-2)(\chi_4)_1 + (2m_1+4m_2-4)(\chi_3)_1 \\ & + (6m_2-2m_1-1)(\chi_2)_1 + (4m_2-3m_1+2)(\chi_1)_1 \\ & + (m_2-m_1+1)(\chi_0)_1 \dots \end{aligned}$$

Whence

$$\begin{aligned} v_5 = & \frac{c^5}{n(n-1)(n-2)(n-3)(n-4)} \{ n^5 + n^4(31m_2 - 10) \\ & + n^3(90m_2^2 + 90m_1m_2 - 220m_2 + 35) \\ & + n^2(65m_2^3 + 195m_1m_2^2 + 130m_1^2m_2 - 485m_2^2 \\ & - 420m_1m_2 + 535m_2 - 50) \\ & + n(15m_2^4 + 90m_1m_2^3 + 165m_1^2m_2^2 + 90m_1^3m_2 \\ & - 245m_2^3 - 645m_1m_2^2 - 370m_1^2m_2 + 600m_1m_2 \\ & + 800m_2^2 - 490m_2 + 24) + m_2^5 + 10m_1m_2^4 \\ & + 35m_1^2m_2^3 + 50m_1^3m_2^2 + 24m_1^4m_2 - 160m_1m_2^3 \\ & - 256m_1^2m_2^2 - 120m_1^3m_2 + 240m_1^2m_2 + 490m_1m_2^2 \\ & - 240m_1m_2 - 30m_2^4 + 213m_2^3 - 380m_2^2 + 120m_2 \}, \end{aligned} \quad (20)$$

and

$$\begin{aligned} \mu_5 &= \nu_5 - 5\nu_1\mu_4 - 10\nu_1^2\mu_3 - 10\nu_1^3\mu_2 - \nu_1^5 \\ &= \frac{c^5 m_2 (n^2 + nm_1 + m_2) (n^2 + 2m_1n + 4m_2)}{n^5 (n-1)(n-2)(n-3)(n-4)} \\ &\quad \times \{n^4 + n^3(10m_2 + 12m_1 + 5) + n^2(10m_1m_2 + 12m_1^2) \\ &\quad + n(10m_2^2 + 24m_1m_2) + 24m_2^2\}. \end{aligned} \quad (21)$$

To determine the value of n , m_1 , and m_2 , let us write

$$\beta_1 = \mu_3^2 / \mu_2^3, \quad \beta_2 = \mu_4 / \mu_2^2, \quad \beta_3 = \mu_5 / (\mu_3 \mu_2);$$

and to render the elimination easier, let us put

$$\left. \begin{aligned} \epsilon &= n^2 + nm_1 + m_2, \\ m_2 \epsilon &= z_2, \\ \epsilon + m_2 &= z_1. \end{aligned} \right\} \dots \dots \dots (22)$$

Then, from (13) and (14),

$$\beta_1 = \frac{(n-1)}{(n-2)^2 z_2} (2z_1 - n^2)^2. \quad (23)$$

From (19) and (14),

$$\beta_2 = \frac{(n-1)}{(n-2)(n-3)z_2} \{n^4 + n^3 + z_2(3n-6) + 6(z_1^2 - n^2 z_1)\}. \quad (24)$$

From (21), (13), and (13),

$$\beta_3 = \frac{(n-1)}{(n-3)(n-4)z_2} \{n^4 + 5n^3 + z_2(10n-24) + 12(z_1^2 - n^2 z_1)\}. \quad (25)$$

These are linear in z_2 ; collecting all the terms of z_2 on the left, we can rewrite (23) to (25),

$$z_2 \beta_1 \frac{(n-2)^2}{n-1} = n^4 + 4(z_1^2 - n^2 z_1), \quad (26)$$

$$z_2 \left\{ \beta_2 \frac{(n-2)(n-3)}{n-1} - (3n-6) \right\} = n^4 + n^3 + 6(z_1^2 - n^2 z_1), \quad (27)$$

$$z_2 \left\{ \beta_3 \frac{(n-3)(n-4)}{n-1} - (10n-24) \right\} = n^4 + 5n^3 + 12(z_1^2 - n^2 z_1). \quad (28)$$

Multiply (26) by 3, and (27) by 2, and subtract the results from (28):

$$z_2 \left\{ \beta_3 \frac{(n-3)(n-4)}{n-1} - 3\beta_1 \frac{(n-2)^2}{n-1} - (10n-24) \right\} = -2n^4 + 5n^3, \quad (29)$$

$$z_2 \left\{ \beta_3 \frac{(n-3)(n-4)}{n-1} - 2\beta_2 \frac{(n-2)(n-3)}{n-1} - (4n-12) \right\} = -n^4 + 3n^3. \quad (30)$$

The last equation will divide by $n-3$, or

$$z_2 \left\{ \beta_3 \frac{n-4}{n-1} - 2\beta_2 \frac{n-2}{n-1} - 4 \right\} = -n^3. \quad (31)$$

Substitute this value of n^3 on the right-hand side of (29), and we have

$$\begin{aligned} \beta_3 \frac{(n-3)(n-4)}{n-1} - 3\beta_1 \frac{(n-2)^2}{n-1} - (10n-24) \\ = (2n-5) \left\{ \beta_3 \frac{n-4}{n-1} - 2\beta_2 \frac{n-2}{n-1} - 4 \right\}, \end{aligned}$$

or

$$\beta_3 \frac{n-4}{n-1}(n-2) - 2\beta_2 \frac{n-2}{n-1}(2n-5) + 3\beta_1 \frac{(n-2)^2}{n-1} + 2(n-2) = 0.$$

Divide out by $\frac{n-2}{n-1}$ and we have

$$\beta_3(n-4) - 2\beta_2(2n-5) + 3\beta_1(n-2) + 2(n-1) = 0,$$

or

$$n(\beta_3 - 4\beta_2 + 3\beta_1 + 2) = 4\beta_3 - 10\beta_2 + 6\beta_1 + 2.$$

Thus

$$n = \frac{4\beta_3 - 10\beta_2 + 6\beta_1 + 2}{\beta_3 - 4\beta_2 + 3\beta_1 + 2}. \quad (32)$$

n being now known (31) gives us

$$z_2 = \frac{n^3(n-1)}{4(n-1) + 2\beta_2(n-2) - \beta_3(n-4)}; \quad (33)$$

z_2 and n being known, we have by (23)

$$z_1 = \frac{1}{2} \left(n^2 + \sqrt{\frac{\beta_1 z_2 (n-2)^2}{n-1}} \right). \quad (34)$$

Then m_2 and ϵ are the roots of the quadratic

$$\zeta^2 - z_1 \zeta + z_2 = 0. \quad (35)$$

m_2 and ϵ being known, we have

$$m_1 = \frac{\epsilon - m_2 - n^2}{n}. \quad (36)$$

Next, α and β are roots of

$$\zeta^2 - m_1 \zeta + m_2 = 0, \quad (37)$$

and

$$\gamma = n + \alpha + \beta + 1. \quad (38)$$

Lastly, from (2)

$$r = -\alpha, \quad q = -\beta/n, \quad \text{and} \quad p = \frac{\gamma - \alpha - 1}{n}. \quad (39)$$

Thus, all the constants p , q , r , and n of the series (1) are determined.

The base unit c is given by (12), or

$$c = n \sqrt{\frac{\mu_2(n-1)}{z_2}} \dots \dots \dots (40)$$

To obtain the successive ordinates of the hypergeometrical frequency-polygon we must, if A be the total number of observations, take the successive terms of

$$1 + r \frac{qn}{pn-r+1} + \frac{r(r-1)}{1 \cdot 2} \frac{qn(qn-1)}{(pn-r+1)(pn-r+2)} + \&c.$$

multiplied by Δ , or

$$\frac{A}{c} \frac{pn(pn-1)(pn-2) \dots (pn-r+1)}{n(n-1)(n-2) \dots (n-r+1)}$$

The position of the first ordinate is at a distance $d = v_1 - c$ from the mean (or centroid-vertical) of the series, *i. e.*

$$d = cm_2/n \dots \dots \dots (41)$$

Thus the solution is fully determined. Its possibility depends on positive and real values for n and r , and for p and q .

As an illustration I take the following data provided for me several years ago by members of my class on the theory of chance at Gresham College.

In a certain 18,600 trials the distribution of frequency was

759 cases of 0 occurrence,			
3277	"	1	"
5607	"	2	occurrences,
5157	"	3	"
2701	"	4	"
907	"	5	"
165	"	6	"
24	"	7	"
1	"	8	"
0	"	9	"
0	"	10	"

Taking moments round the point corresponding to three occurrences I find

$\mu_1' = - .501,4516,$	$\mu_4' = 8.433,6021,$
$\mu_2' = 1.815,5376,$	$\mu_5' = -10.504,6774.$
$\mu_3' = -1.948,5484$	

Thus the mean is :

$$2\cdot498,5484;$$

and transferring moments to this mean, we have

$$\mu_2 = 1\cdot564,0839,$$

$$\mu_3 = \cdot530,4806,$$

$$\mu_4 = 7\cdot074,6464,$$

$$\mu_5 = 7\cdot903,2620;$$

and

$$\beta_1 = \cdot073,5460,$$

$$\beta_2 = 2\cdot891,9091,$$

$$\beta_3 = 9\cdot525,2597.$$

Substituting in (32) we find

$$n = 65\cdot203,378.$$

Hence by (33)

$$z_2 = 451,811\cdot067,$$

and (34)

$$z_1 = 2839\cdot1404.$$

Thus

$$\zeta^2 - 2839\cdot1404\zeta + 451,811\cdot067 = 0.$$

This leads to

$$m_2 = 169\cdot2229,$$

$$\epsilon = 2669\cdot9175.$$

Whence by (36)

$$m_1 = -26\cdot85115.$$

Thus (37) is now

$$\zeta^2 + 26\cdot85115\zeta + 169\cdot2229,$$

and

$$\alpha = -10\cdot10546,$$

$$\beta = -16\cdot74569.$$

Then from (40) we find

$$c = \cdot972077,$$

and from (41)

$$d = 2\cdot5229.$$

Thus we conclude that the frequency may be represented by a hypergeometrical series of which the start is $\cdot0244$ before zero occurrence, the base unit is $\cdot9721$, and the mean is at $2\cdot4985$. Further, from (39)

$$r = 10\cdot1055,$$

$$p = \cdot7432,$$

$$q = \cdot2568;$$

or

$$pn = 48\cdot4577,$$

$$qn = 16\cdot7457.$$

Further, we conclude that the range of frequency cannot be

greater than 10, and the whole distribution might be closely represented by drawing 10 balls 18,600 times out of a bag containing 17 white and 48 black balls, and counting the white occurrences in each draw. Actually the frequency was obtained by drawing 10 cards out of an ordinary pack of 52 and counting the hearts in each draw. Thus we have :—

	Actually.	From theory.
Start at	0	—·0244
Mean	2·5	2·4988
Number drawn ...	10	10·1055
Base unit	1	·9721
p	·75	·7432
q	·25	·2568
n	52	65·2034

Now it is clear that the first six results are in good agreement, but that n diverges from its actual value by 25 per cent. although the number of trials, 18,600, is far larger than are recorded in most practical cases.

It is of interest to record the actual and theoretical frequencies :—

No. of hearts.	Observed.	Theory.
0	759	747·5
1	3277	3239
2	5607	5642
3	5159	5172
4	2701	2743
5	907	871
6	165	166
7	24	18·5
8	1	1
9	0	0
10	0	0

The deviations are four positive and four negative, and four above and four below their respective probable errors. Thus the experimental results are in good accordance with theory.

Notwithstanding this, n has a large deviation from its theoretical value when determined by moments. It is clearly a quantity, when thus determined, liable to very large probable error. Thus, while the problem is theoretically fully solved—and it is difficult to believe that any other solution can have less probable error—yet we meet, unless we take an immense number of trials, with large variations in our estimate of the number from which the drawing is made. I have tested this

on a variety of series in games of chance and on biostatistical data,—a small change in a high moment makes a large change in n . Accordingly we are liable to form quite erroneous impressions of the nature of the hypergeometrical series, and even to reach impossible values for p , q , and r , which are determined through n . Thus the problem, which is practically an important one, as enabling us to test the sufficiency of the usual hypothesis, $n = \infty$, of the theory of errors, *i. e.* to test the “independence or interdependence of contributory causes,” is seen to admit of a solution, but one which is hardly likely to be of much service unless in the case to which it is applied a very large amount of data is available.

XVI. On James Bernouilli's Theorem in Probabilities.

By LORD RAYLEIGH, F.R.S.*

IF p denote the probability of an event, then the probability that in μ trials the event will happen m times and fail n times is equal to a certain term in the expansion of $(p+q)^\mu$, namely,

$$\frac{\mu!}{m!n!} p^m q^n, \quad \dots \dots \dots (1)$$

where $p+q=1$, $m+n=\mu$.

“Now it is known from Algebra that if m and n vary subject to the condition that $m+n$ is constant, the greatest value of the above term is when m/n is as nearly as possible equal to p/q , so that m and n are as nearly as possible equal to μp and μq respectively. We say *as nearly as possible*, because μp is not necessarily an integer, while m is. We may denote the value of m by $\mu p + z$, where z is some proper fraction, positive or negative; and then $n = \mu q - z$.”

The r th term, counting onwards, in the expansion of $(p+q)^\mu$ after (1) is

$$\frac{\mu!}{m-r!n+r!} p^{m-r} q^{n+r}. \quad \dots \dots (2)$$

The approximate value of (2) when m and n are large numbers may be obtained with the aid of Stirling's theorem, *viz.*

$$\mu! = \mu^{\mu+\frac{1}{2}} e^{-\mu} \sqrt{(2\pi)} \left\{ 1 + \frac{1}{12\mu} + \dots \right\}. \quad \dots (3)$$

* Communicated by the Author.

The process is given in detail after Laplace in Todhunter's 'History of the Theory of Probability,' p. 549, from which the above paragraph is quoted. The expression for the r th term after the greatest is

$$\frac{e^{-\frac{\mu r^2}{2mn}} \sqrt{\mu}}{\sqrt{(2\pi mn)}} \left\{ 1 + \frac{\mu r z}{mn} + \frac{r(n-m)}{2mn} - \frac{r^3}{6m^2} + \frac{r^3}{6n^2} \right\}; \quad (4)$$

and that for the r th term before the greatest may be deduced by changing the sign of r in (4).

It is assumed that r^2 does not surpass μ in order of magnitude, and fractions of the order $1/\mu$ are neglected.

There is an important case in which the circumstances are simpler than in general. It arises when $p=q=\frac{1}{2}$, and μ is an even number, so that $m=n=\frac{1}{2}\mu$. Here z disappears *ab initio*, and (4) reduces to

$$\frac{2e^{-2r^2/\mu}}{\sqrt{(2\pi\mu)}}, \dots \dots \dots (5)$$

representing (2), which now becomes

$$\frac{\mu!}{2^\mu \cdot \frac{1}{2}\mu - r! \frac{1}{2}\mu + r!} \dots \dots \dots (6)$$

An important application of (5) is to the theory of random vibrations. If μ vibrations are combined, each of the same phase but of amplitudes which are at random either $+1$ or -1 , (5) represents the probability of $\frac{1}{2}\mu + r$ of them being positive vibrations, and accordingly $\frac{1}{2}\mu - r$ being negative. In this case, and in this case only, is the resultant $+2r$. Hence if x represent the resultant, the chance of x , which is necessarily an *even* integer, is

$$\frac{2e^{-x^2/2\mu}}{\sqrt{(2\pi\mu)}}.$$

The next greater resultant is $(x+2)$; so that when x is great the above expression may be supposed to correspond to a range for x equal to 2. If we represent the range by dx , the chance of a resultant lying between x and $x+dx$ is given by

$$\frac{e^{-x^2/2\mu} dx}{\sqrt{(2\pi\mu)}} \dots \dots \dots (7)*$$

Another view of this matter, leading to (5) or (7) without the aid of Stirling's theorem, or even of formula (1), is given

* Phil. Mag. vol. x. p. 75 (1880).

(somewhat imperfectly) in 'Theory of Sound,' 2nd ed. § 42 *a*. It depends upon a transition from an equation in finite differences to the well-known equation for the conduction of heat and the use of one of Fourier's solutions of the latter. Let $f(\mu, r)$ denote the chance that the number of events occurring (in the special application *positive vibrations*) is $\frac{1}{2}\mu + r$, so that the *excess* is r . Suppose that each random combination of μ receives *two* more random contributions—*two* in order that the whole number may remain even,—and inquire into the chance of a subsequent excess r , denoted by $f(\mu + 2, r)$. The excess after the addition can only be r if previously it were $r - 1, r, \text{ or } r + 1$. In the first case the excess becomes r by the occurrence of both of the two new events, of which the chance is $\frac{1}{4}$. In the second case the excess remains r in consequence of one event happening and the other failing, of which the chance is $\frac{1}{2}$; and in the third case the excess becomes r in consequence of the failure of both the new events, of which the chance is $\frac{1}{4}$. Thus

$$f(\mu + 2, r) = \frac{1}{4}f(\mu, r - 1) + \frac{1}{2}f(\mu, r) + \frac{1}{4}f(\mu, r + 1). \quad (8)$$

According to the present method the limiting form of f is to be derived from (8). We know, however, that f has actually the value given in (6), by means of which (8) may be verified.

Writing (8) in the form

$$f(\mu + 2, r) - f(\mu, r) = \frac{1}{4}f(\mu, r - 1) - \frac{1}{2}f(\mu, r) + \frac{1}{4}f(\mu, r + 1), \quad (9)$$

we see that when μ and r are infinite the left-hand member becomes $2df/d\mu$, and the right-hand member becomes $\frac{1}{4}d^2f/dr^2$, so that (9) passes into the differential equation

$$\frac{df}{d\mu} = \frac{1}{8} \frac{d^2f}{dr^2} \quad \dots \quad (10)$$

In (9), (10) r is the excess of the actual occurrences over $\frac{1}{2}\mu$. If we take x to represent the difference between the number of occurrences and the number of failures, $x = 2r$ and (10) becomes

$$\frac{df}{d\mu} = \frac{1}{2} \frac{d^2f}{dx^2} \quad \dots \quad (11)$$

In the application to vibrations $f(\mu, x)$ then denotes the chance of a resultant $+x$ from a combination of μ unit vibrations which are positive or negative at random.

In the formation of (10) we have supposed for simplicity that the addition to μ is 2, the lowest possible consistently with the total number remaining even. But if we please we may suppose the addition to be any even number μ' . The

analogue of (8) is then

$$2^{\mu'} \cdot f(\mu + \mu', r) = f(\mu, r - \frac{1}{2}\mu') + \mu' f(\mu, r - \frac{1}{2}\mu' + 1) \\ + \frac{\mu'(\mu' - 1)}{1 \cdot 2} f(\mu, r - \frac{1}{2}\mu' + 2) + \dots + f(\mu, r + \frac{1}{2}\mu');$$

and when μ is treated as very great the right-hand member becomes

$$f(\mu, r) \left\{ 1 + \mu' + \frac{\mu'(\mu' - 1)}{1 \cdot 2} + \dots + \mu' + 1 \right\} \\ + \frac{1}{8} \frac{d^2 f}{dr^2} \left\{ 1 \cdot \mu'^2 + \mu'(\mu' - 2)^2 + \frac{\mu'(\mu' - 1)}{1 \cdot 2} (\mu' - 4)^2 \right. \\ \left. + \dots + \mu'(\mu' - 2)^2 + 1 \cdot \mu'^2 \right\}$$

The series which multiplies f is $(1+1)^{\mu'}$, or $2^{\mu'}$. The second series is equal to $\mu' \cdot 2^{\mu'}$, as may be seen by comparison of coefficients of x^2 in the equivalent forms

$$(e^x + e^{-x})^n = 2^n (1 + \frac{1}{2}x^2 + \dots)^n \\ = e^{nx} + ne^{(n-2)x} + \frac{n(n-1)}{1 \cdot 2} e^{(n-4)x} + \dots$$

The value of the left-hand member becomes simultaneously

$$2^{\mu'} \{ f + \mu' df/d\mu \};$$

so that we arrive at the same differential equation (10) as before.

This is the well-known equation for the conduction of heat, and the solution developed by Fourier is at once applicable. The symbol μ corresponds to time and r to a linear co-ordinate. The special condition is that initially—that is when μ is relatively small— f must vanish for all values of r that are not small. We take therefore

$$f(\mu, r) = \frac{A}{\sqrt{\mu}} e^{-2r^2/\mu}, \quad \dots \dots \dots (12)$$

which may be verified by differentiation.

The constant A may be determined by the understanding that $f(\mu, r) dr$ is to represent the chance of an excess lying between r and $r + dr$, and that accordingly

$$\int_{-\infty}^{+\infty} f(\mu, r) dr = 1. \quad \dots \dots \dots (13)$$

Since $\int_{-\infty}^{+\infty} e^{-z^2} dz = \sqrt{\pi}$, we have

$$\frac{A}{\sqrt{\mu}} = \sqrt{\left(\frac{2}{\pi\mu}\right)}; \quad \dots \dots \dots (14)$$

and, finally, as the chance that the excess lies between r and $r + dr$,

$$\sqrt{\left(\frac{2}{\pi\mu}\right)} e^{-2r^2/\mu} dr. \dots \dots \dots (15)$$

Another method by which A in (12) might be determined would be by comparison with (6) in the case of $r=0$. In this way we find

$$\begin{aligned} \frac{A}{\sqrt{\mu}} &= \frac{\mu!}{2^\mu \cdot \frac{1}{2}\mu! \cdot \frac{1}{2}\mu!} = \frac{1 \cdot 3 \cdot 5 \dots \mu-1}{2 \cdot 4 \cdot 6 \dots \mu} \\ &= \sqrt{\left(\frac{2}{\pi\mu}\right)} \text{ by Wallis' theorem.} \end{aligned}$$

If, as is natural in the problem of random vibrations, we replace r by x , denoting the difference between the number of occurrences and the number of failures, we have as the chance that x lies between x and $x + dx$

$$\frac{e^{-x^2/2\mu} dx}{\sqrt{(2\pi\mu)}}, \dots \dots \dots (16)$$

identical with (7).

In the general case when p and q are not limited to the values $\frac{1}{2}$, it is more difficult to exhibit the argument in a satisfactory form, because the most probable numbers of occurrences and failures are no longer definite, or at any rate simple, fractions of μ . But the general idea is substantially the same. The excess of occurrences over the most probable number is still denoted by r , and its probability by $f(\mu, r)$. We regard r as continuous, and we then suppose that μ increases by unity. If the event occurs, of which the chance is p , the total number of occurrences is increased by unity. But since the most probable number of occurrences is increased by p , r undergoes only an increase measured by $1-p$ or q . In like manner if the event fails, r undergoes a decrease measured by p . Accordingly

$$f(\mu + 1, r) = pf(\mu, r - q) + qf(\mu, r + p). \dots (17)$$

On the right of (17) we expand $f(\mu, r - q)$, $f(\mu, r + p)$ in powers of p and q . Thus

$$f(\mu, r + p) = f + \frac{df}{dr} p + \frac{1}{2} \frac{d^2f}{dr^2} p^2,$$

$$f(\mu, r - q) = f - \frac{df}{dr} q + \frac{1}{2} \frac{d^2f}{dr^2} q^2;$$

so that the right-hand member is

$$(p+q)f + \frac{1}{2} \frac{d^2f}{dr^2} (p^2q + pq^2), \quad \text{or} \quad f + \frac{1}{2} pq \frac{d^2f}{dr^2}.$$

The left-hand member may be represented by $f + df/d\mu$, so that ultimately

$$\frac{df}{d\mu} = \frac{1}{2} pq \frac{d^2f}{dr^2}. \quad \dots \dots \dots (18)$$

Accordingly by the same argument as before the chance of an excess r lying between r and $r + dr$ is given by

$$\frac{1}{\sqrt{(2\pi pq\mu)}} e^{-r^2/2pq\mu} dr. \quad \dots \dots \dots (19)$$

We have already considered the case of $p=q=\frac{1}{2}$. Another particular case of importance arises when p is very small, and accordingly q is nearly equal to unity. The whole number μ is supposed to be so large that $p\mu$, or m , representing the most probable number of occurrences, is also large. The general formula now reduces to

$$\frac{1}{\sqrt{(2\pi m)}} e^{-r^2/2m} dr, \quad \dots \dots \dots (20)$$

which gives the probability that the number of occurrences shall lie between $m + r$ and $m + r + dr$. It is a function of m and r only.

The probability of the deviation from m lying between $\pm r$

$$= \frac{2}{\sqrt{(2\pi m)}} \int_0^r e^{-r^2/2m} dr = \frac{2}{\sqrt{\pi}} \int_0^\tau e^{-r^2} d\tau, \quad \dots \dots (21)$$

where $\tau = r/\sqrt{(2m)}$. This is equal to .84 when $\tau=1.0$, or $r = \sqrt{(2m)}$; so that the chance is comparatively small of a deviation from m exceeding $\pm \sqrt{(2m)}$. For example, if m is 50, there is a rather strong probability that the actual number of occurrences will lie between 40 and 60.

The formula (20) has a direct application to many kinds of statistics.

XVII. Notices respecting New Books.

Textbook of Algebra with exercises for Secondary Schools and Colleges.

By G. E. FISHER, M.A., Ph.D., and I. J. SCHWATT, Ph.D. Part I.
(pp. xiv + 683: Philadelphia, Fisher & Schwatt, 1898).

THIS is a big book for the comparatively small extent of ground it covers. The usual elementary parts are discussed up to and including simultaneous Quadratic equations, and then, in the remaining 80 pages, we have an account of Ratio, Proportion, Variation, Exponents, and Progressions. The Binomial Theorem for a positive Integral Exponent occupies about a dozen pages, the treatment by Combinations being reserved, we presume, for Part II.

The text has been very carefully drawn up and should be useful for young teachers. The distinction between the signs of operation and the signs of quality is very clearly indicated by means of a special notation. There is a good chapter on the interpretation of the solutions of Problems, such questions as that of the problem of the couriers and allied problems being worked out in some detail. In some few places one would have expected the Authors to have been a little fuller, but the general level is high. The exercises are very numerous and well graded. The number is intentionally large "that the teacher from year to year may have Variety with different classes." There is no mention of *Graphs*, a branch of the subject which Prof. Chrystal's book brings into prominence. The book can be recommended as a sound treatise on the elements of Algebra, and the printers have done their work well. The most important typographical error we have come across is on p. 611 line 5, where for "first" read "second." There are no answers at the end.

XVIII. *Intelligence and Miscellaneous Articles.*

RELATIVE MOTION OF THE EARTH AND ÆTHER.

To the Editors of the Philosophical Magazine.

GENTLEMEN,

IN your September number Dr. Lodge comments on my objection to the conclusiveness of the Michelson-Morley æther experiment, and I should like to point out that his remarks are founded on a strange misconception of the nature of my objection. He conjectures that I attribute the negative result of the Michelson and Morley experiment "to the possible second-order influence of a hitherto neglected first-order tilting or shifting of the wave-fronts brought about by the undiscovered drift of the æther past the earth." But in my communication I pointed out that my objection was not of this nature, but related to the assumption made as to the optical sensitiveness of the system of interference-fringes relied on by the experimenters to enable them to measure the minute length in question in their experiments. My contention was simply that the system of fringes used in the experiment had probably a more complex character than was supposed, and that therefore its capability of measuring the small length accurately was over-rated to an unknown extent. Evidently Dr. Lodge has pondered so deeply on aberration problems that in reading my paper his thought has got into some old groove which he has unconsciously taken to be the direction of my argument.

Yours obediently,

WILLIAM SUTHERLAND.

Postscript by Prof. LODGE.—I was not very clear about Mr. Sutherland's precise line of argument, nor am I now; but there was an imaginary loophole which others might attempt to get through, though Mr. Sutherland, as it now appears, did not; and I took the opportunity (not specially opportune as it turns out) of indicating that it was closed.

THE
LONDON, EDINBURGH, AND DUBLIN
PHILOSOPHICAL MAGAZINE
AND
JOURNAL OF SCIENCE.

[FIFTH SERIES.]

MARCH 1899.



XIX. *On the Theory of the Conduction of Electricity through Gases by Charged Ions.* By J. J. THOMSON, M.A., F.R.S., Cavendish Professor of Experimental Physics, Cambridge*.

THE electrical conductivity possessed by gases under certain circumstances—as for example when Röntgen or uranium rays pass through the gas, or when the gas is in a vacuum-tube or in the neighbourhood of a piece of metal heated to redness, or near a flame or an arc or spark-discharge, or to a piece of metal illuminated by ultra-violet light—can be regarded as due to the presence in the gas of charged ions, the motions of these ions in the electric field constituting the current.

To investigate the distribution of the electric force through the gas we have to take into account (1) the production of the ions; this may either take place throughout the gas, or else be confined to particular regions; (2) the recombination of the ions, the positively charged ions combining with the negatively charged ones to form an electrically neutral system; (3) the movement of the ions under the electric forces. We shall suppose in the subsequent investigations that the velocity of an ion is proportional to the electric intensity acting upon it. The velocity acquired by an ion under a given potential gradient has been measured at the Cavendish Laboratory by several observers—in the case of gases exposed to the Röntgen rays by Rutherford and by Zeleny; for gases exposed to uranium radiation or to

* Communicated by the Author.

ultra-violet light by Rutherford; for the ions in flames by McClelland and H. A. Wilson; and for the ions in gases near to incandescent metals or to the arc discharge by McClelland. The velocities in the different cases vary very much; the velocity of an ion in the same gas is much the same whether the conductivity is due to Röntgen rays, uranium rays, or ultra-violet light; it is much smaller when the conductivity is produced by an arc or by incandescent metal. Thus the mean velocity of the positive and negative ions under a volt per centimetre in air exposed to Röntgen rays was found by Rutherford to be about 1.6 cm./sec., while for gas drawn from the neighbourhood of an arc-discharge in carbonic acid the mean velocity of the positive and negative ions was found by McClelland to be only .0035 cm./sec.

This difference is caused by the ions acting as nuclei about which condensation, whether of the gas around them or of water-vapour present in the gas, takes place. The power of these ions to act as nuclei for the condensation of water-vapour is strikingly shown by C. T. R. Wilson's* experiments on the effects of Röntgen and uranium radiation on the formation of clouds, and also by R. v. Helmholtz's† experiments on the effects produced by ions on a steam jet. If the size of the aggregation which forms round the ion depends on the circumstances under which the ion is liberated and the substances by which it is surrounded, the velocity which the ion acquires under a given potential gradient will also depend on these circumstances, the larger the mass of the aggregation the smaller will be this velocity. A remarkable result of the determination of the velocities acquired by the ions under the electric field is that the velocity acquired by the negative ion under a given potential gradient is greater than (except in a few exceptional cases when it is equal to) the velocity acquired by the positive ion. Greatly as the velocities of the ions produced in different ways differ from each other, yet they all show this peculiarity. The relative velocities of the negative and positive ions differ very much in the different cases of conduction through gases; thus in the case of imperfectly dried hydrogen traversed by the Röntgen rays, Zeleny found that the speed of the negative ions was about 25 per cent. greater than that of the positive, while in the case of conduction through hot flames H. A. Wilson found that the velocity of the negative ion was 17 or 18 times that of the positive. In the case of the discharge through vacuum-tubes, the measurements which I made of

* Wilson, Phil. Trans. A, 1897; Proceedings of Cambridge Phil. Soc. vol. ix. p. 333.

† R. v. Helmholtz, Wied. Ann. vol. xxvii. p. 509 (1886).

the ratio of the charge to the mass for the particles constituting the cathode rays and those of W. Wien* for the ions carrying the positive charge indicate that the ratio of the velocity of the negative ion to that of the positive one under the same potential gradient would be very large. This fact is, I think, sufficient to account for most of the differences between the appearances at the positive and negative electrodes in a vacuum-tube. Schuster (*Proc. Roy. Soc.* vol. xlvii. p. 526, 1890), from observations on the rates at which positively and negatively electrified bodies lost their charges in a vacuum-tube, came to the conclusion that the negative ions diffused more rapidly than the positive; other phenomena connected with the discharge led me later (*Phil. Mag.* vol. xl. p. 511, 1895) independently to the same result.

We shall now proceed to find equations satisfied by the electric intensity in a gas containing charged ions. To simplify the analysis we shall suppose that the electric force is everywhere parallel to the axis of x , and that if X is the value of the electric intensity at a point, the velocity of the positive ion at that point is k_1X , and that of the negative ion in the opposite direction k_2X ; we shall suppose that at this point the number of positive ions per unit volume is n_1 , the number of negative ions n_2 ; let q be the number of positive or negative ions produced at this point in unit volume in unit time: the number of collisions per unit time between the positive and negative ions is proportional to n_1n_2 . We shall suppose that in a certain fraction of these collisions recombination between the positive and negative ions takes place, so that a number αn_1n_2 of positive and negative ions disappear in unit time from unit volume in consequence of the recombination of the ions. If e is the charge carried by each ion, the volume density of the electrification is $(n_1 - n_2)e$, hence we have

$$\frac{dX}{dx} = 4\pi(n_1 - n_2)e, \quad \dots \dots \dots (1)$$

if ι is the current through unit area of the gas, and if we neglect any diffusion except that caused by the electric field,

$$k_1n_1eX + k_2n_2eX = \iota, \quad \dots \dots \dots (2)$$

and if things have settled into a steady state, ι is constant throughout the gas; from these equations we have

$$n_1e = \frac{1}{k_1 + k_2} \left\{ \frac{\iota}{X} + \frac{k_2}{4\pi} \frac{dX}{dx} \right\}, \quad \dots \dots \dots (3)$$

$$n_2e = \frac{1}{k_1 + k_2} \left\{ \frac{\iota}{X} - \frac{k_1}{4\pi} \frac{dX}{dx} \right\}. \quad \dots \dots \dots (4)$$

* W. Wien, *Verhandl. der phys. Gesellsch. zu Berlin*, vol. xvi. p. 165.

In a steady state the number of positive ions in unit volume at a given place remains constant, hence

$$\frac{d}{dx}(k_1 n_1 X) = q - \alpha n_1 n_2, \dots \dots \dots (5)$$

and

$$-\frac{d}{dx}(k_2 n_2 X) = q - \alpha n_1 n_2.$$

Substituting in either of these equations the values of $n_1 n_2$ previously found we get, since $d\iota/dx=0$,

$$\frac{1}{4\pi e} \frac{k_1 k_2}{k_1 + k_2} \frac{d}{dx} \left(X \frac{dX}{dx} \right) = q - \frac{\alpha}{X^2 e^2 (k_1 + k_2)^2} \left(\iota + \frac{k_2}{4\pi} X \frac{dX}{dx} \right) \left(\iota - \frac{k_1}{4\pi} X \frac{dX}{dx} \right)$$

If we put $X^2 = 2y$,

$$\frac{dy}{dx} = p,$$

this equation becomes

$$\frac{1}{4\pi e} \frac{k_1 k_2}{k_1 + k_2} p \frac{dp}{dy} = q - \frac{\alpha}{2ye^2(k_1 + k_2)^2} \left(\iota + \frac{k_2}{4\pi} p \right) \left(\iota - \frac{k_1}{4\pi} p \right).$$

I have not been able to integrate this equation in the general case when q is finite and k_1 not equal to k_2 . We can, however, integrate it when q is constant and $k_1 = k_2 = k$. In this case the equation may be written

$$\pi \frac{d}{dy} \left(\frac{k^2}{16\pi^2} p^2 - \iota^2 \right) = \frac{\alpha}{8ek} \frac{1}{y} \left(\frac{k^2}{16\pi^2} p^2 - \iota^2 \right) + qek,$$

the solution of which is

$$\frac{k^2}{16\pi^2} p^2 - \iota^2 = \frac{qek}{\pi \left(1 - \frac{\alpha}{8\pi ek} \right)} y + C(2y)^{\frac{\alpha}{8\pi ek}},$$

where C is a constant of integration.

If the current through the gas passes between two parallel plates maintained at a constant potential-difference, $dX/dx=0$ midway between the plates; at the positive plate $n_1=0$, while $n_2=0$ at the negative plate; hence if X_0, X_1 be respectively the values of X midway between the plates and at either plate, we have, putting $p=0$, to get X_0

$$-\iota^2 = \frac{\frac{qek}{4\pi}}{1 - \frac{\alpha}{8\pi ek}} X_0^2 + CX_0^{\frac{\alpha}{4\pi ek}}.$$

But

$$\iota = 2nkeX_0,$$

since when $dX/dx=0$, $n_1=n_2$.

The measurements of X for gases exposed to Röntgen rays show that unless the current is approaching the maximum value it can attain, X is practically constant for some distance near the middle of the plates; hence in this case we have $d^2X/dx^2=0$ midway between the plates, and therefore by equations (3) and (5) $q=\alpha n^2$; substituting this value of n we have

$$-X_0^2 \left(\frac{4k^2e^2q}{\alpha} + \frac{\frac{qek}{2\pi}}{1 - \frac{\alpha}{8\pi ek}} \right) = CX_0 \frac{\alpha}{4\pi ek};$$

or

$$-X_0^2 \frac{\frac{4k^2e^2q}{\alpha}}{1 - \frac{\alpha}{8\pi ek}} = CX_0 \frac{\alpha}{4\pi ek}. \quad \dots \dots \dots (6)$$

At either plate $n_1n_2=0$, so that $\frac{k^2}{16\pi^2}p^2 - \iota^2=0$, thus

$$-X_1^2 \frac{\frac{qek}{2\pi}}{1 - \frac{\alpha}{8\pi ek}} = CX_1 \frac{\alpha}{4\pi ek}; \quad \dots \dots \dots (7)$$

hence from (6) and (7)

$$\frac{8\pi ke}{\alpha} = \left(\frac{X_0}{X_1} \right)^{\frac{\alpha}{4\pi ek} - 2};$$

or if $\frac{8\pi ke}{\alpha} = \beta$,

$$\frac{X_1}{X_0} = \beta^{\frac{1}{2-2/\beta}}. \quad \dots \dots \dots (8)$$

It follows from this equation that X_1/X_0 is greater than unity, and that the value of this ratio increases from unity to infinity as β increases from zero to infinity. We see that β does not involve either q or ι . So that, to take a particular case, when the gas between two plates is exposed to Rontgen rays, the ratio of the electric intensity at the plates to that midway between them is independent of the intensity of the radiation and of the current through the gas. The curves

giving the connexion between the electric intensity and the distance between the plates are found by experiment to be somewhat as represented in fig. 1. The variation in X (fig. 1)

Fig. 1.



occurs only in two layers near the plates and X is approximately constant in the rest of the field. As the current through the gas increases the layers of inconstant X expand until they touch, and then there is no longer a region in which X is constant. We can easily find an inferior limit to the value of λ the thickness of one of these layers when we are given the value of the current. For suppose P (fig. 1) is at the boundary of the layer next the positive electrode, then at P , since X becomes constant, half the current must be carried by the positive and half by the negative ions; if i is the current and e the charge carried by an ion, then $i/2e$ positive ions must cross unit area of a plane through P in unit time, so that at least that number must be produced in unit time in the region between P and the positive plate. Now if λ is the thickness of the layer, $q\lambda$ is the number of positive ions produced in unit time; the number that cross the plane in unit time cannot then be greater than $q\lambda$, and will only be as great as this if no recombination of the ions takes place; hence

$$q\lambda > \frac{i}{2e},$$

or

$$\lambda > \frac{i}{2qe}.$$

Thus $i/2eq$ is an inferior limit to λ . It will not, however, I think be very far from the true value, for we can show that but little recombination will take place in the time taken by the positive ions to traverse a layer of this thickness. For the rate of combination of the positive ions is given by

$$\frac{dn_1}{dt} = -\alpha n_1 n_2.$$

If N_2 is the maximum value of n_2 , then $\frac{1}{\alpha N_2}$ measures the time that is taken before recombination diminishes the number of the ions to any very appreciable extent. In this time the positive ions would move a distance δ given by the equation

$$\delta = \frac{kX_1}{\alpha N_2},$$

where X_1 is the value of X at the plate.

$$kN_2X_1e = \iota;$$

thus

$$\delta = \frac{k^2X_1^2e}{\alpha\iota}.$$

Let $X_1 = \gamma X_0$ where $\gamma = \beta^{\frac{1}{2-2/\beta}}$,

$$\begin{aligned} \delta &= \frac{\gamma^2 k^2 X_0^2 e}{\alpha \iota} \\ &= \frac{\gamma^2 \iota}{4qe} = \frac{\gamma^2}{2} \lambda. \end{aligned}$$

Thus if γ is tolerably large, the positive ions will traverse a space much greater than λ before recombining.

The greatest current that can pass between the plates is when all the ions are used in carrying the current; if l is the distance between the plates, then lq positive and negative ions are produced in unit time; thus if I is the maximum current which can pass between the plates

$$I = lqe;$$

hence we can write

$$\frac{\lambda}{l} = \frac{\iota}{2I}.$$

The equations

$$\frac{dX}{dx} = 4\pi(n_1 - n_2)e,$$

$$\frac{d}{dx}(k_1 n_1 X) = q - \alpha n_1 n_2,$$

$$\frac{d}{dx}(k_2 n_2 X) = -(q - \alpha n_1 n_2),$$

$$(k_1 n_1 + k_2 n_2) X e = \iota,$$

are satisfied by

$$n_1 = n_2 = \{q/\alpha\}^{\frac{1}{2}},$$

$$k_1 n_1 X e = \frac{k_1}{k_1 + k_2} \iota,$$

$$k_2 n_2 X e = \frac{k_2}{k_1 + k_2} \iota,$$

$$X = \left(\frac{\alpha}{q}\right)^{\frac{1}{2}} \frac{\iota}{e(k_1 + k_2)},$$

where ι is the current through the gas. In this case the amounts of the current carried by the positive and negative ions respectively are proportional to the velocities of those ions. When, however, the current passes between two parallel plates, this solution cannot hold right up to the plates. For, consider the condition of things at a point P, between the plates AB and CD, of which AB is the positive and CD the negative plate. Then across unit area at P

$$\frac{k_1}{k_1 + k_2} \frac{\iota}{e}$$

positive ions pass in unit time, and these must come from the region between P and AB; this region can, however, not furnish more than $q\lambda$, and only as much as this if there are no recombinations; hence the preceding solution cannot hold when the distance from the positive plate is less than

$$\frac{k_1}{k_1 + k_2} \frac{\iota}{qe};$$

similarly it cannot hold nearer the negative plate than the distance

$$\frac{k_2}{k_1 + k_2} \frac{\iota}{qe}.$$

We shall assume that the solution given above does hold in the parts of the field which are further away from the plates than these distances; and further, that in the layers in which this solution does not hold, there is no recombination of the ions. Let us now consider the condition of things near the positive plate between

$$x = 0 \quad \text{and} \quad x = \frac{k_1}{k_1 + k_2} \frac{\iota}{qe} = \lambda \text{ say.}$$

Then, since in this region there is no recombination, our

equations are

$$\frac{dX}{dx} = 4\pi(n_1 - n_2)e,$$

$$\frac{d}{dx}(k_1 n_1 X) = q,$$

$$\frac{d}{dx}(k_2 n_2 X) = -q.$$

If q is constant, we have

$$k_1 n_1 X = qx,$$

$$k_2 n_2 X = \frac{v}{e} - qx,$$

the constant has been determined so as to make $n_1 = 0$ when $x = 0$; substituting these values for n_1, n_2 , in the equation giving dX/dx we get

$$X \frac{dX}{dx} = 4\pi e \left\{ qx \left(\frac{1}{k_1} + \frac{1}{k_2} \right) - \frac{v}{ek_2} \right\},$$

or

$$X^2 = 8\pi e \left\{ \frac{qx^2}{2} \left(\frac{1}{k_1} + \frac{1}{k_2} \right) - \frac{vx}{ek_2} \right\} + C;$$

the constant may be determined from the condition that when $x = \lambda_1$

$$X^2 = \frac{\alpha}{q} \frac{v^2}{e^2(k_1 + k_2)^2},$$

from this we find

$$C = \frac{\alpha}{q} \frac{v^2}{e^2(k_1 + k_2)^2} \left\{ 1 + \frac{4\pi e}{\alpha} \frac{k_1}{k_2} (k_1 + k_2) \right\},$$

Since C is the value of X^2 when $x = 0$, it is the value of X^2 at the positive plate; if we call X_1 the value of X at the positive plate and X_0 the value of X between the layers we have

$$X_1 = X_0 \left\{ 1 + \frac{4\pi e}{\alpha} \frac{k_1}{k_2} (k_1 + k_2) \right\}^{\frac{1}{2}},$$

thus X_1 is always greater than X_0 , the value of X between the layers.

If X_2 is the value of X at the negative plate we have

$$X_2 = X_0 \left\{ 1 + \frac{4\pi e}{\alpha} \frac{k_2}{k_1} (k_1 + k_2) \right\}^{\frac{1}{2}}.$$

Thus, if k_2 , the velocity of the negative ion, is very large

compared with k_1 , the velocity of the positive, the value of X at the negative plate is large compared with its value at the positive.

The curve representing the electric intensity between the plates is shown in fig. 2. In this case k_2/k_1 is a large quantity.

Fig. 2.

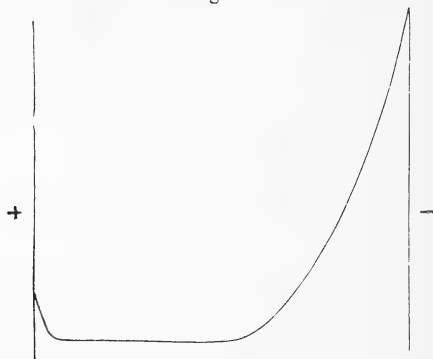

The fall of potential across the layer whose thickness is λ_1 is equal to

$$\int_0^{\lambda_1} X dx,$$

and this is equal to

$$\frac{1}{2} X_1 \lambda_1 + \frac{1}{2} \frac{X_0 \lambda_1}{\sqrt{\beta}} \log (\sqrt{\beta} + \sqrt{1 + \beta}),$$

where

$$\beta = \frac{4\pi e}{\alpha} \frac{k_1}{k_2} (k_1 + k_2),$$

and

$$X_1 = X_0 (1 + \beta)^{\frac{1}{2}},$$

Hence, if β is large, the fall of potential across the layer whose thickness is λ_1 next the positive plate, is approximately

$$\frac{1}{2} X_1 \lambda_1 = \frac{1}{2} X_0 (1 + \beta)^{\frac{1}{2}} \frac{k_1}{k_1 + k_2} \frac{t}{qe},$$

Similarly, if

$$\beta_1 = \frac{4\pi e}{\alpha} \frac{k_2}{k_1} (k_1 + k_2),$$

and if β_1 is large the fall of potential across the layer whose thickness is λ_2 is approximately

$$\frac{1}{2} X_2 \lambda_2 = \frac{1}{2} X_0 (1 + \beta_1)^{\frac{1}{2}} \frac{k_2}{k_1 + k_2} \frac{t}{qe}.$$

The distance between the plates in which the electric intensity is constant and equal to X_0 is $l - (\lambda_1 + \lambda_2)$, where l is the distance between the plates. Since $\lambda_1 + \lambda_2 = \iota/qe$ the fall of potential in this distance is equal to

$$X_0 \left(l - \frac{\iota}{qe} \right);$$

hence if V is the potential-difference between the plates

$$V = X_0 \left\{ \frac{1}{2}(1 + \beta)^{\frac{3}{2}} \frac{k_1}{k_1 + k_2} \frac{\iota}{qe} + \frac{1}{2}(1 + \beta_1)^{\frac{3}{2}} \frac{k_2}{k_1 + k_2} \frac{\iota}{qe} + l - \frac{\iota}{qe} \right\},$$

and

$$X_0 = \left(\frac{\alpha}{q} \right)^{\frac{1}{2}} \frac{\iota}{e(k_1 + k_2)},$$

so that

$$V = \left(\frac{\alpha}{q} \right)^{\frac{1}{2}} \frac{\iota}{e(k_1 + k_2)} \left\{ \frac{1}{2}(1 + \beta)^{\frac{3}{2}} \frac{k_1}{k_1 + k_2} \frac{\iota}{qe} + \frac{1}{2}(1 + \beta_1)^{\frac{3}{2}} \frac{k_2}{k_1 + k_2} \frac{\iota}{qe} - \frac{\iota}{qe} + l \right\}.$$

This gives the relation between the current and the potential-difference between the plates. It is of the form

$$V = A\iota^2 + B\iota.$$

In a paper by Mr. Rutherford and myself in the *Phil. Mag.* for Oct. 1896, a relation between V and ι was given on the assumption that the electric intensity was constant between the plates; in this investigation I have tried to allow for the variation in the electric intensity. The above investigation ceases to be an approximation to the truth when the two layers touch each other. In this case the current has its limiting value lqe , and there is no loss of ions by recombination; we may therefore neglect the recombination and proceed as follows.

Equations (5) become in this case

$$\frac{d}{dx}(k_1 n_1 X) = q,$$

$$\frac{d}{dx}(k_2 n_2 X) = -q.$$

If q is constant, the solutions of these equations are

$$k_1 n_1 X = qx, \quad \dots \dots \dots (9)$$

$$k_2 n_2 X = q(l - x), \quad \dots \dots \dots (10)$$

where x is the distance measured from the positive plate and l the distance between the plates, for these solutions satisfy

264 Prof. J. J. Thomson on the Theory of Conduction of the differential equations and the boundary conditions $n_1=0$ when $x=0$, and $n_2=0$ when $x=l$. From the equation

$$\frac{dX}{dx} = 4\pi(n_1 - n_2)e,$$

we have

$$X \frac{dX}{dx} = 4\pi qe \left\{ x \left(\frac{1}{k_1} + \frac{1}{k_2} \right) - \frac{l}{k_2} \right\},$$

or

$$X^2 = 8\pi qe \left\{ \frac{x^2}{2} \left(\frac{1}{k_1} + \frac{1}{k_2} \right) - \frac{lx}{k_2} \right\} + C, \quad \dots \quad (11)$$

where C is the constant of integration. When X has its minimum value we see from equation (1) that $n_1=n_2$; hence from (9) and (10) at such a point we have

$$\frac{k_1}{k_2} = \frac{x}{l-x}; \quad \dots \quad (12)$$

hence if we determine the point Q where X is a minimum, this equation will give us the ratio of the velocities of the positive and negative ions.

We see that a positive ion starting from the positive plate, and a negative ion starting from the negative plate, reach this point simultaneously.

If X_0 is the minimum value of X , and ξ the distance of a point between the plates from Q , we may write equation (11) in the form

$$X^2 = X_0^2 + 4\pi qe \xi^2 \left(\frac{1}{k_1} + \frac{1}{k_2} \right);$$

if I is the maximum current, this may be written

$$X^2 = X_0^2 + 4\pi I \xi^2 \frac{1}{l} \left(\frac{1}{k_1} + \frac{1}{k_2} \right). \quad \dots \quad (13)$$

We see from this equation that if we measure the values of X at two points and I , the maximum current, we can deduce the value of

$$\frac{1}{k_1} + \frac{1}{k_2},$$

and since from (12) we know the value of k_1/k_2 , we can deduce the values of k_1 and k_2 .

If the positive ion moves more slowly under a given potential gradient than the negative ion, then we see from (12) that Q is nearer to the positive than to the negative

plate. Hence it follows from (13) that the electric force at the negative plate is greater than that at the positive.

A very convenient method of determining the velocities of the ions, and one which can be employed in nearly every case of conduction through gases, is to produce the ions in one region and measure the electric intensity at two points in a region where there is no production of ions, but to which ions of one sign only can penetrate under the action of the electric field. Thus let A, B represent two parallel plates immersed in a gas, and let us suppose that in the layer between A and the plane LM we produce a supply of ions, whether by Röntgen rays, incandescent metals, ultra-violet light, or by other means, and suppose that the gas between LM and B is screened off from the action of the ionizer. Then if A and B are connected to the poles of a battery a current will pass through the gas, and this current in the region between LM and B will be carried by ions of one sign. These will be positive if A is the positive pole, negative if it is the negative pole. Let us find the distribution of electric intensity in the region between LM and B. Let us suppose A is the positive plate, then all the ions in this region are positive and we have, using the same notation as before,

$$\frac{dX}{dx} = 4\pi n_1 e,$$

$$k_1 n_1 X e = \iota,$$

where ι is the current through unit area ; from these equations we have

$$X \frac{dX}{dx} = \frac{4\pi \iota}{k_1},$$

or

$$X^2 = \frac{4\pi \iota}{k_1} x + C.$$

Hence if we measure the values of X at two points in the region between LM and B, and also the value of ι , we can, from this equation, deduce the value of k_1 , and hence the velocity of the positive ion in a known electric field. To determine the velocity of the negative ion we have only to perform a similar experiment with the plate A negative.

When the ionization is confined to a layer CD between the plates A and B, the distribution of electric intensity is repre-

sented by fig. 3, where A is the positive and B the negative plate, and the velocity of the negative ion is supposed to be much greater than that of the positive.

Fig. 3.

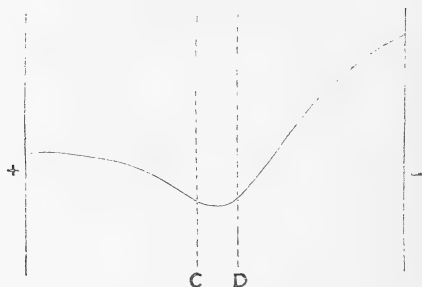

The investigation of the distribution of electric intensity given on p. 262 shows that when the velocity of the negative ion is much greater than that of the positive, the distribution of the intensity has many features in common with that associated with the passage of electricity through a vacuum-tube, especially the great increase in electric intensity close to the negative electrode. Thus this feature of the discharge through vacuum-tubes can be explained by the greater velocity of the negative ion than of the positive, a property which seems to hold in all cases of discharge of electricity through gases. And as the most important of the differences between the phenomena at the two poles of a vacuum-tube are direct consequences of the electric intensity at the cathode far exceeding that at the anode, I think the most striking features of the discharge through vacuum-tubes are consequences of the difference in velocity between the positive and negative ions. In the case discussed on p. 261 we assumed q constant, *i. e.* that the ionization along the path of the discharge was constant; in the case of the discharge through vacuum-tubes, where the ionization is due primarily to the electric field itself, it is unlikely that the ionization will be constant when the field is so variable. We can derive information as to the distribution of the ionization by a study of the very valuable curves giving the distribution of electric intensity in a vacuum-tube which we owe to the researches of Graham (*Wied. Ann.* lxiv. p. 49, 1898).

From the equations

$$\frac{dX}{dx} = 4\pi(n_1 - n_2)e,$$

$$\frac{d}{dx}(k_1 n_1 X) = q - \alpha n_1 n_2,$$

$$-\frac{d}{dx}(k_2 n_2 X) = q - \alpha n_1 n_2,$$

we get if k_1 and k_2 are independent of x ,

$$\frac{d^2 X^2}{dx^2} = 8\pi e(q - \alpha n_1 n_2) \left(\frac{1}{k_1} + \frac{1}{k_2} \right).$$

Thus $q - \alpha n_1 n_2$ is of the same sign as $d^2 X^2 / dx^2$. Thus when $q - \alpha n_1 n_2$ is positive, that is when the ionization exceeds the recombination, the curve for X^2 will be convex to the axis of x , and this curve will be concave to the axis of x when the recombination exceeds the ionization. Places of sharp curvature will be regions either of great ionization or recombination. Fig. 4 is a curve for X^2 calculated from Graham's

Fig. 4.

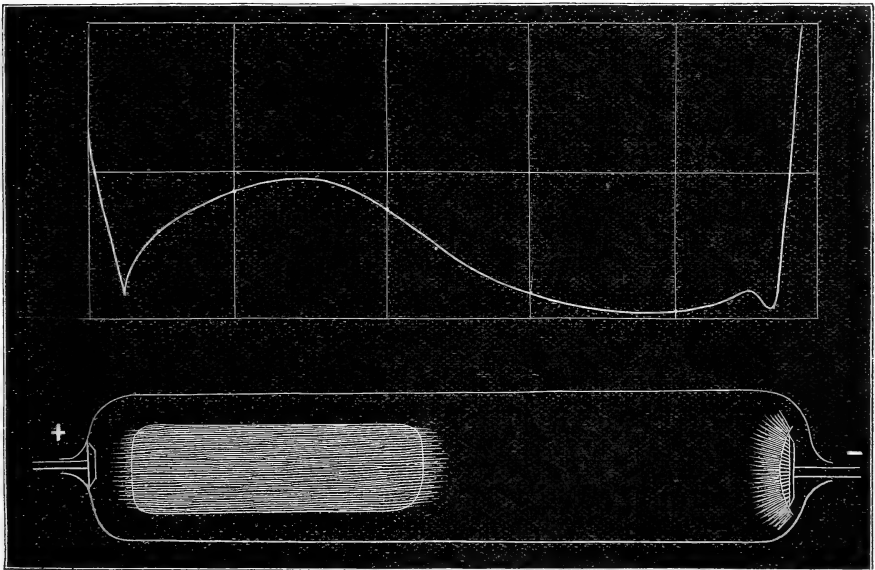

results. It will be seen that there are two places of specially sharp curvature with the curvature in the direction denoting ionization, one, the most powerful one, just outside the negative dark space, the other near the anode, while in the positive light the curvature indicates recombination. It would seem as if the positive ions formed at the centre of

ionization near the anode, in travelling towards the cathode, met with the negative ions coming from the centre of ionization near the cathode, that these positive ions combine with the negative until their number is exhausted, and on combining give out light, the region of recombination constituting the positive light. In the dark space between the positive light and the negative glow these positive ions from the centre of ionization near the anode are exhausted, so that there are none of them left for the negative ions coming from the centre near the cathode to combine with.

The nick in the curve denoting the centre of ionization near the cathode is present in all the curves given by Graham; the centre near the anode is not nearly so persistent. In several of the curves given by Graham there is no nick near the anode, though the one near the cathode is well marked, and in these tubes there is no well-developed positive light. The distribution of potential which accompanies the luminous discharge requires a definite distribution of electrification in the tube, this requires ionization and a movement of the ions in the tube before the luminous discharge takes place. There must, therefore, be a kind of quasi-discharge to prepare the way for the luminous one. Warburg (*Wied. Ann.* lxii. p. 385) has, in some cases, detected a dark discharge before the luminous one passes. It seems probable that such a discharge is not limited to the cases in which it has already been detected, but is an invariable preliminary to the luminous discharge.

Besides the "nicks" or places of specially sharp curvature fig. 4 shows that there is a small curvature in the direction indicating an excess of ionization over recombination all through the considerable space that intervenes between the positive light and the negative glow; as this region is one far away from places of great electric intensity it seems probable that in producing ionization the electric intensity at any point is helped by other agencies. The case of the cathode rays shows that the motion of charged ions tends to ionize the surrounding gas. E. Wiedemann, too, has shown that the discharge generates a peculiar radiation, called by him "Entladungstrahlen"; it is possible that these may possess the power of ionizing a gas through which they pass.

XX. *Cathode, Lenard, and Röntgen Rays.*

By WILLIAM SUTHERLAND*.

TO explain the results of his experiments on cathode rays, and to account for the Hertz-Lenard apparent passage of cathode rays through solid bodies according to Lenard's wonderfully simple law, J. J. Thomson (*Phil. Mag.* [5] xlv., Oct. 1897) proposes the hypothesis, that the matter in the cathode stream consists of atoms resolved into particles of that primitive substance out of which atoms have been supposed to be composed. Before a theory of such momentous importance should be entertained, it is necessary to examine whether the facts to be explained by it are not better accounted for by the logical development of established or widely accepted principles of electrical science.

The chief facts which Thomson arrives at from his experiments are:—That the cathode rays travel at the same speed in different gases such as hydrogen, air, and carbonic dioxide; and that m/e , the ratio of the mass of the particles to their charge, is the same for the cathode streams in all gases, and is about 10^{-3} of the ratio of the mass of the hydrogen atom to its charge in ordinary electrolysis. These seeming facts have also been brought out with great distinctness in the experiments of Kaufmann (*Wied. Ann.* lxi. and lxii.). Whatever proves to be the right theory of the nature of the cathode rays, the quantitative results which these experimenters have obtained (as did also Lenard), in a region, where, amid a bewildering wealth of qualitative work, the quantitative appeared as if unattainable, must constitute a firm stretch of the roadway to the truth.

Let us briefly consider the theories used by J. J. Thomson and by Kaufmann to interpret their experiments. For instance, Thomson considers N particles projected from the cathode, each of mass m , to strike a thermopile, to which they give up their kinetic energy $\frac{1}{2}Nmv^2$ measured as W . Each of the particles carries its charge of electricity e , the whole quantity Ne being measured as Q . Thus we have

$$\frac{1}{2}v^2m/e = W/Q. \quad (1)$$

But again, the particles, after being projected through a slit in the anode with velocity v , are subjected to a field H of magnetic force at right angles to the direction of motion, so that the actual force tending to deflect each particle is Hev at right angles to H and v . The result is that each particle describes a circular path of radius ρ with the centrifugal

* Communicated by the Author.

force mv^2/ρ equal to Hev , and therefore our second equation is

$$vm/e = H\rho. \quad (2)$$

By measuring W/Q and $H\rho$, Thomson is able to deduce values of v and m/e from (1) and (2), and these are the values which lead to his remarkable conclusions already given.

Thomson and Kaufmann control the results of this method by a second method of experimenting, in which deflexion of cathode rays was produced by electrostatic force, as well as by magnetic, the forces in Thomson's experiments being adjusted so that the deflexions in both cases were the same, and therefore, if F is the electric force,

$$Fe = Hev. \quad (3)$$

Thus an independent measure of v is taken, and as it confirms those made by the other method, the experimental evidence for the simplicity of the laws of cathode motion is greatly strengthened. But in the theory of these experiments there is one suppressed premiss, namely, that a charge e must be associated with some mass m . Now in following up the ionic hypothesis as far as it will go, it is our duty to use this premiss as one of the links in the chain of reasoning; but when it leads us to a conclusion subversive of the ionic hypothesis, namely, that atoms are split up into particles having different charges from the atomic charge in electrolysis, then we are no longer bound by the ionic hypothesis. It may therefore be that free electrons can appear in the æther, and that in the cathode stream the greater part of the electricity travels as free electrons.

A systematic statement of the reasons for contemplating the possibility of the motion of free electrons through the æther will be given below; but in the present connexion it is of most importance to consider whether such electrons could give up to the thermopile the kinetic energy measured by Thomson. From the writings of Thomson, Heaviside, Searle, and Morton (Phil. Mag. [5] xi., xxvii., xxviii., xli., xliv.) we can form an idea as to what takes place when an electron is set in motion. These writings relate to electric charges on conducting spheres and ellipsoids, the charges being caused to move by the motion of the conductors; but in the case of the free electron we cannot say that its charge is on anything, unless a modified portion of the æther. Our simplest plan is to regard the electron as a spherical shell of electricity of total amount e , the radius being a .

The main effect of setting such an electron in motion by means of some source of energy, is that electric and magnetic

energy are spread into the æther with the velocity of light V , so that when the electron has velocity u the total amount of such electric and magnetic energy is (Searle, *Phil. Mag.* xlv.)

$$\frac{e^2}{2Ka} \left(\frac{V}{u} \log \frac{V+u}{V-u} - 1 \right).$$

If u is small compared with V this is

$$\frac{e^2}{2Ka} \left(1 + \frac{2}{3} \frac{u^2}{V^2} + \dots \right);$$

and taking account only of the part of this energy due to motion, we have Heaviside's result:—

$$e^2 u^2 / 3KaV^2 \quad \text{or} \quad \mu e^2 u^2 / 3a.$$

Now if the process, by which some of our store of energy was converted into electric and magnetic forms on setting the electron in motion, is a reversible one, then on stopping the electron in a suitable manner the electric and magnetic energy ought to flow back to our source or to the stopping body, and if there are no arrangements at the stopping body suitable for storing this as ordinary kinetic or potential energy, it will appear as heat amongst the particles which take part in the stoppage. Thus, then, certain actions of a moving electron take place as if it had a localized inertia, just as in the theory of electric currents a large part of their behaviour is such as it would be if the moving electricity had localized inertia. According to Searle's expression, the inertia or effective mass of the electron becomes a function of its velocity, if we define it as the quantity which is to be multiplied by half the square of the velocity to give the kinetic energy. With Heaviside's expression for smaller velocities, we should have the inertia equal to $2\mu e^2 / 3a$. But apart from these details, we have only to assume that the energy imparted to an electron when it is set in motion (or the greater part of it) is given up as heat to the material particles which arrest its motion, and is equal to half the square of the velocity multiplied by a certain quantity characteristic of the electron and appearing by the symbol m in the equations of Thomson and Kaufmann. Then the experimental results are at once explained; for as the negative electrons are the same in all the experiments, m/e has the same value for cathode streams in all gases: the gas facilitates the electric discharge, but does not control it; as a steam-engine can give the same results with several lubricants, so the cathode stream can give the same stream of electric energy by means of its

moving free electrons, whatever may be the gas used to facilitate its flowing.

We can use Thomson's and Kaufmann's value of m/e , namely, about 10^{-7} when e is measured in electromagnetic units, to calculate the order of magnitude of a the radius of the electron. With the relation $m/e = 2\mu e/3a$ and $\mu = 1$ and $e = 10^{-21}$ in the electromagnetic system of units, we then have $a = 10^{-14}$ nearly, while the radii of molecules are of the order 10^{-8} cm., so that the linear dimensions of an electron are about the millionth part of those of molecules. We must therefore concede to the electron great freedom of motion in the interstices between the molecules even of solid bodies.

A very remarkable fact about the equations of motion of the cathode stream used by Thomson is that, although the velocity attained is about one-third that of light, there is no sign of any necessity to take account of appreciable frictional resistance. The electrons stream through the æther with nearly the velocity of light and yet provoke no noticeable resistance. What wonder, then, that any æthereal resistance to planetary motion has remained beyond our ken!

The importance of the quantitative results in these experiments has necessitated their being discussed out of their historical and logical order in a train of thought on cathode and allied rays, which order we will now attempt to follow briefly.

Stoney's interpretation of Faraday's law of Electrolysis to mean that electricity exists in separate natural units, the electrons, as definitely as matter in atoms, is now generally accepted, after Helmholtz's independent advocacy of it in his Faraday lecture.

Many workers have investigated the general dynamics of electrons, but mostly on the supposition that the electron must be associated with an atom, so that they form in conjunction an ion. But if electric action in matter is to be explained only by the participation of electrons, it naturally follows that we should contemplate the existence of electrons in the æther to enable it to play its part in electrical action.

And next we have to take account of the hypothesis advanced by Helmholtz in his Faraday lecture (Chem. Soc. Trans. xxxix. 1881) to explain Contact Electromotive Force, namely, that different atoms attract electrons with different amounts of force. This hypothesis may not be generally accepted yet, but we propose to follow out its logical consequences. If two things attract one another they must be entities of somewhat the same sort, and therefore the electron is

of essentially the same nature as an atom. But further, if two things attract one another, we must conceive the possibility of their being drawn apart, so that the ion can be split into an uncharged atom and an electron free of attachment to matter. Maxwell's ascription of inertia to electricity, in his theory of induced currents, bears out our conclusion that the atom and the electron are things of the same sort in many respects. If the electrons are distributed through the æther, we must suppose that in æther showing no electric charge each negative electron is united with a positive electron to form the analogue of a material molecule, which might conveniently be called a neutron. Of the existence of neutrons in the æther we have powerful evidence in Trowbridge's wonderful experiments ("The Electrical Conductivity of the Æther," *Phil. Mag.* [5] xliii., May 1897). He opens his account of them with a mention of Edlund's old contention that the æther is a conductor and J. J. Thomson's refutation of it, and closes it with the statement, "My experiments lead me to conclude that under very high electrical stress the æther breaks down and becomes a good conductor." Thus both Edlund's contention and J. J. Thomson's are happily reconciled; the æther is a perfect insulator until it is broken down, after which it is a conductor. According to the present theory, Trowbridge's result would be worded thus:—The æther insulates until the electric force at some point is sufficient to decompose the neutrons into electrons, whereupon it becomes a conductor of the same type as electrolytes. This principle should help practical electricians to construct a consistent theory of the hitherto rather intractable electric arc.

But to return to the cathode rays. The volume of experimental and theoretical work on the ionization of gases, which has been turned out from the Cavendish Laboratory, leaves no doubt as to the existence of ions in rare gases through which a current of electricity is passing: hence in the cathode stream there must be a certain number of ions flying along side by side with the electrons; but the experiments of Thomson and Kaufmann, according to our interpretation, prove that the stream of ions is of quite subsidiary importance to the stream of electrons. This is not always necessarily the case in the electric discharge through gases, and it seems to me that, for a satisfactory theory of the varied phenomena of electric conduction through gases, we must take account of the fact that we have two conducting media participating in the action namely, varying numbers of ions and also of free electrons.

Our theory of the cathode stream has the advantage that it

leads in a most natural manner to a theory of the Lenard rays. The cathode stream of electrons, moving with a velocity nearly that of light, possessing inertia, and yet of a size that is small compared to the molecular interspaces in solids, must be able to penetrate a solid that is thin enough, and to emerge on the other side, differing from the original cathode stream only in that the small trace of moving ions has been filtered out. Practically then Lenard rays are cathode rays. This is what experiment has abundantly proved. All the main properties of the cathode rays have been re-observed in the Lenard rays: thus Perrin proves that the cathode stream carries negative electricity, M'Clelland proves the same for the Lenard rays: Röntgen discovers that where the cathode stream strikes a solid it emits Röntgen rays; Des Coudres proves that where the Lenard rays strike a solid they also emit Röntgen rays: Goldstein discovered that the cathode stream colours salts, especially haloid salts of the alkalis, in a remarkable way; Des Coudres proves the same for the Lenard stream: and so on with such properties as magnetic and electric deflectability, power of exciting luminescence, and the like. The cathode and Lenard streams are the simplest forms of electric current known to us. Such a power as that of causing certain substances to emit light is only another form of our fundamental principle, that an electron in having its motion arrested imparts energy to the arresting molecules, and of course to their associated electrons. The colouring of salts discovered by Goldstein would be accounted for by the supposition that some of the negative electrons attach themselves to the electronegative atoms, thereby converting them into free ions, and liberating uncharged atoms of the metal, which cause the coloration. The experiments which have been made, with negative results, to detect the metal or the ion chemically do not decide anything, because of course the amounts produced are too small for ordinary methods of analysis to detect. The fatigue, which some substances show after fluorescing for a while under the influence of the cathode stream, may be accounted for in a similar manner by the lodgement of free electrons, which produce an opposing electromotive force and diminish the intensity of the cathode stream, while at the same time producing an analogous change to the change of colour in the salts studied by Goldstein, except that the change does not appear as visible colour, but as a lowering of fluorescent power. Fluorescence is known to be very sensitive to the presence of small traces of substances.

We do not know enough of the relations of atoms and

electrons to formulate *à priori* what ought to be the law of the resistance of bodies to the passage of a stream of electrons through them; but fortunately we have the comprehensive investigations of Lenard on the subject and can give a reasonable explanation of his results. He found (*Wied. Ann.* lvi.) that for a great variety of substances of densities varying from that of hydrogen at 3 mm. of mercury pressure ($\cdot 0_6368$) to that of gold ($19\cdot 3$), the resistance to the passage of Lenard rays depended almost solely on density, the coefficient of absorption being proportional to the density. Now we should expect our electron being so small compared to atoms, and moving with high velocities, to deform locally any atom which it strikes, and to rebound before the deformation had travelled far into the substance of the atom, so that after the electron had departed the atom would be left with an increase of vibrational energy, but no direct appreciable increase of translatory energy; then, if the velocity of propagation of a disturbance in all atoms is the same, and also the time of an encounter between atom and electron constant, the energy given up by an electron in an encounter with an atom will be proportional to the density of the substance of the atom. Now in the case of a solid, as an electron threads its way through the molecular interspaces, the number of its encounters will be proportional to the length of path, and therefore to the thickness of the solid, and therefore the coefficient of absorption, which will relate to unit thickness of all substances, will be proportional to the density of the substance of the atom, which is nearly the same as the density of the substance; thus for solids we interpret Lenard's law of the absorption of cathode rays.

In the case of gases an interesting difference presents itself. The electron is not now threading its way through narrow passages, but has far more clear space than obstacle ahead of it. As the electron is very small itself, we may say that in passing through a gas the number of times it encounters a molecule is proportional to the mean sectional area, and therefore to the square of the radius R of the molecule regarded as a sphere, and also to the number of molecules per unit volume (n); and if m is the mass of the molecule the density of its substance is proportional to m/R^3 , and thus the coefficient of absorption for a gas is proportional to nR^2m/R^5 or nm/R ; but nm is the density ρ , so that the coefficient of absorption of a gas is proportional to the density, but also inversely proportional to the molecular radius. Now this theoretical conclusion corresponds partly with one of Lenard's experimental results, namely, that although the coefficient of

absorption for a large number of gases appeared to be proportional to the density within the limits of experimental error, the coefficient for hydrogen was exceptional to an extent decidedly beyond possible experimental error. In his experiments, Lenard showed that if J_0 is the intensity of a Lenard stream at its source, J that at a distance r from the source in a substance whose coefficient of absorption is A ,

$$J = J_0 e^{-Ar/r^2},$$

and determined A for various gases at a pressure of one atmo. As the densities of these gases are as their molecular weights, with that of hydrogen = 2, he shows the relation of A to the density of different gases by tabulating values of A/m ; while according to our reasoning RA/m would be expected to be constant. The following table contains Lenard's values of $10^3 A/m$, and relative values of R as given in my paper on the "Attraction of Unlike Molecules—The Diffusion of Gases," Phil. Mag. [5] xxxviii., being half the cube-root of the limiting space occupied by a gramme-molecule of the substance and controlled by comparison with molecular dimensions as given by experiments on the viscosity of gases; the last row contains the product $10^3 RA/m$:—

	H ₂ .	CH ₄ .	CO.	C ₂ H ₄ .	N ₂ .	O ₂ .	CO ₂ .	N ₂ O.	SO ₂ .
$10^3 A/m$...	237	124	122	132	113	126	115	102	133
R	1.025	1.47	1.35	1.75	1.415	1.34	1.56	1.535	1.63
$10^3 RA/m$...	243	182	165	231	160	169	179	157	217

Thus while Lenard's approximate constant ranges from 102 to 237, the one to which we have been led ranges from 157 to 243, which is an improvement. The really striking point about Lenard's discovery, however, is that when A is divided by density, the range in value is from 2070 for paper to 5610 for hydrogen at one atmo; the results for many substances such as gold and hydrogen at 1/228 atmo falling between these extremes. The fact that the value of A/ρ for a rare gas is almost the same as for a dense solid, would seem to indicate that it is only when an electron strikes an atom almost in the direction of a normal that the most important part of the absorption of energy occurs; for if this is so, the chance of an electron's encountering an atom in a solid normally, while threading its way through the interstices, being the same as if it could pass through all the atoms which it does not meet normally, the absorption of energy from an electron by a number of atoms should be the same whether they are as close as in a solid or as wide apart as in a rarefied gas. Thus probably the coefficient of absorption for a solid

depends on its molecular radius, but the data hardly permit of an examination into this point. It should be remarked that, as the electron can probably pass easily between the atoms in a molecule, the absorption due to a compound molecule ought to be analysed into the parts due to its atoms; for instance, in Lenard's table of values for A in such gases as CH_4 , CO_2 , C_2H_4 , the part due to the carbon, the hydrogen, and the oxygen, ought to be separated out, and then each part ought to be proportional to the atomic mass and inversely proportional to the atomic radius. If this is so, then the agreement in the values of RA/m in our table could not be expected to be perfect.

A very characteristic property of the Lenard rays follows from our theory, for when the cathode rays fall on an aluminium window, such as Lenard used, they have a direction normal to it, whereas the Lenard rays issuing on the other side of the window are uniformly radiated in all directions; and this is exactly how our stream of small electrons would behave, because after they have threaded their way through the molecular interstices, they will issue with directions uniformly distributed in space, for it is to be presumed that the final directions of the intermolecular passages will be distributed at random.

As the cathode and Lenard streams are currents of electrons, and therefore form pure electric currents, we might expect *à priori* that the coefficient of absorption of substances for them would show some decided relation to the electrical resistance of the substances; but Lenard's law proves that such an expectation would be futile, for the absorption of conductor and insulator alike depends almost entirely on density. This fact throws considerable light on the nature of metallic conduction. It would seem as if in the conduction of electricity in metals, both the positive and negative electrons, distributed through the metals, take part in the process of conduction, probably in the method of the Grothuss chain; by a process of exchange of partners both kinds of electron get passed along in opposite directions without anything of the nature of a great rush of one kind of electron at one time and place. When such a rush occurs in a cathode stream, the internal appliances of the best conducting metal can no more facilitate its passage, than can the obstructing appliances of the best insulator hinder it. In metallic conduction we have to do with a property of the metallic atom, whereby, with the aid of electromotive force, the local dissociation of the neutron into electrons is greatly facilitated; whereas in insulators the reverse is the case. This important field of the

relations of electrons and atoms must be nearly ready for important developments.

Two more of Lenard's facts are of special importance, namely, that cathode rays, when passed through a window from the vacuum-tube in which they are generated, travel as Lenard rays through gas of such a density as would prevent the formation of the cathode rays, if it prevailed in the tube, whether that density is great, as in the ordinary atmosphere, or very small, as in a vacuum so high as to insulate under the electric forces in the tube. These facts are explained by our theory: the properly exhausted tube furnishes a requisite facility for splitting up the neutrons and getting a supply of electrons to be set swiftly in motion; once that is accomplished, nothing will stop them until it offers enough resistance to destroy the momentum of the electrons, and ordinary lengths of dense or rare air in Lenard's experiments failed to do this. The action of the tube in generating the cathode rays may be likened in this connexion to a Gifford's Steam Injector.

In the logical development of the present line of thought, an attempt at an explanation of the cause of the Röntgen rays must find a place. Already J. J. Thomson, in his paper on a Connexion between Cathode and Röntgen Rays (*Phil. Mag.* [5] xlv., Feb. 1898), has worked out in some detail the electromagnetic effect of suddenly stopping ions moving with high velocity, the main result being that thin electromagnetic pulses radiate from the ion. He believes that these pulses constitute the Röntgen rays, in agreement with a surmise of Stokes. Thomson's reasoning would apply to our free electrons just as to his ions, but there would be this important distinction, that while Thomson's hypothesis involves the condition that the greater part of the energy of the cathode stream consists of the kinetic energy of the atoms, in our hypothesis the energy belongs almost entirely to the moving electrons, and when these are stopped the energy appears as heat at the place of stoppage. Thus Thomson's electromagnetic pulses appear only as subsidiary phenomena in connexion with the conversion of the kinetic energy of the electrons into heat; indeed, we cannot be sure that they exist, because their existence has been suggested only in accordance with the particular assumptions in Thomson's hypothesis which correspond to only a limited portion of the complete electrodynamics of such an action as is contemplated in this paper, causing the conversion of all or almost all the kinetic energy of an electron into heat. Moreover, in tracing the relation of Lenard rays to cathode rays we have been led to picture the stoppage of the moving electrons as nothing

like so sudden as that which Thomson has to contemplate for his charges: this of course only makes a difference in the degree of intensity of the phenomena resulting from the stoppage. There has as yet been no systematic proof that the properties of a train of impulses would be the same as those of the Röntgen rays in the matter of the absence of refraction and reflexion. Again, it is recognized that the Röntgen rays and the Becquerel rays from uranium are very similar, but it would be hard to imagine the Becquerel rays to be due to thin impulses. On these grounds it seems to me that Thomson's suggestion as to the cause of the Röntgen rays, although exciting one's admiration by its clear consistency, does not lead to the desired end; and therefore I will try to follow out the premisses of this paper to such conclusions as may relate to phenomena like those of the Röntgen rays.

To the electrons we have assigned inertia and size, and we must therefore ascribe to them shape; but a general conception of shape involves also the notion of deformability, which, therefore, we must consider as a possible property of the electron. The electron is therefore to be supposed capable of emitting vibrations due to the relative motions of its parts; as light is supposed to be due to the motion of electrons as wholes, we see that the internal vibrations of electrons will have this much in common with light, that they are transmitted by the same æther, but they need have nothing else in common. We propose, then, to identify the Röntgen rays with these internal vibrations of our electrons. It might be expected that the electron, in executing the motions which cause light, would get strained and thrown into internal vibration, so that Röntgen rays would accompany ordinary light; but the fact that Röntgen rays cannot be detected in association with light shows that the motion of the electron occurs either so that it is very free from shock and strain, or so that atoms promptly damp any internal vibrations of adjacent electrons. The way in which matter absorbs the energy of Röntgen rays shows that we may rely on atoms to suppress any small amount of Röntgen radiation that might tend to accompany ordinary light as emitted by electrons. Thus, then, appreciable Röntgen radiation is to be looked for only when free electrons are thrown into vigorous internal vibration. Now the encounter of an electron with an atom, in which it gives up a part of its kinetic energy to the atom as heat, is precisely the sort of action by which we should expect the electron to be thrown into internal vibration. Internal vibrations should originate where cathode or Lenard

rays are absorbed, and most powerfully where the absorption is most powerful: this corresponds with all the facts as to the place of origin of Röntgen rays.

As to what must be the order of magnitude of the length of the waves in the æther produced by the internal vibrations of the electrons, we can form no *à priori* estimate, but under the circumstances we are at liberty to assume that, like the size of the electron, it is small compared to that of atoms, and small also compared to molecular interspaces. We shall then have to do with systems of waves, which, when they fall on a body, can travel freely in the molecular interspaces, but are liable to absorption near the surfaces of molecules. The propagation of such a system of waves would take place almost entirely in the æther of the interspaces, as sound travels through a loose pile of stones mostly by the air-spaces; the molecules cause absorption, but do not act as if they loaded the æther. Therefore when our system of waves enters a body it experiences no refraction. As to reflexion at the first layer of molecules which it encounters, we must remember that our wave-length is small compared to the radius of a molecule or atom, and that therefore in studying reflexion it suffices to study that from a single molecule; whereas, with ordinary light, where the wave-length is large compared to atomic radius, we have to take the effect of a large number of contiguous molecules, if we are to reason out results comparable with those observed in ordinary reflexion. Now the reflexion of our small waves from a single molecule will be of the same nature as reflexion from a sphere, and will be similar to diffuse scattering, a good deal of the scattering being towards the neighbouring interstices. Thus the attempt to reflect these waves from a material plane surface will be similar to that of attempting to reflect ordinary light from a large number of smooth spheres whose centres lie in a plane. If we take the average effect of a large number of molecules whose centres are by no means in a plane, as must be the case with our best reflecting surfaces, we see that a diffuse scattering of our small waves must take the place of reflexion, and this is the experimental result with the Röntgen rays.

Any polarization that our system of waves might possess could not be detected by the ordinary optical appliances, because these depend on actions exercised by the molecules on the vibrations of light, whereas, as our small waves travel by the interstices between the molecules, their character is not controlled to any appreciable extent by the molecular structure. This result also agrees with the experimental one

that polarization of the Röntgen rays cannot be detected by ordinary optical apparatus for the purpose.

These negative properties have been explained chiefly by the assumed smallness of the wave-length, and have, therefore, little direct connexion with our theory of the Röntgen rays beyond indicating the probability of a small wave-length for the Röntgen rays for similar reasons to those usually urged. We must, therefore, proceed to properties that our short waves must possess by virtue of their origin in vibrating electrons. In the first place, we should expect the electrons forming the neutrons in the æther to be set vibrating by our waves ; but if they produce no dissipation of the energy they will not cause any absorption, but will simply participate in the general æthereal operations of propagating the waves. But when the waves get amongst the electrons associated with atoms, and set them vibrating internally, there is called forth that resistance to the vibration which constitutes the damping action already spoken of. One of the probable results of such an action would be the setting of the acting and reacting atom and electron into relative motion, so causing the absorbed Röntgen energy to appear as some form of radiant energy congenial to the atom and electron. In this way our waves could give rise to fluorescent and photographic effects in the manner of the Röntgen rays. If an electron absorbs enough of the energy of our small waves, it may be set into such vigorous motion as to escape from the atom with which it is acting and reacting, and appear as a free electron, or it may associate itself with an electron* to form an ion. At the foundation of our theory we suppose our small waves to be produced by the deformation of an electron during a vigorous transfer of energy from electron to atom ; and now we suppose this to be a reversible action, so that an electron set vibrating near to an atom can convert enough of its vibrational energy into translational kinetic energy to escape from the atom. With this legitimate dynamic assumption of reversibility, we can deduce from our hypothesis the production of free electrons or ions in a dielectric traversed by our small waves, which is in agreement with the remarkable property possessed by the Röntgen rays of making gases conduct electricity well. The presence of scattered ions in a solid dielectric does not necessarily make it conduct. An experimental method of testing our theoretical conclusion, that Röntgen rays ought to have the same effect on solid dielectrics as on gases, would be to heat one till it gave decided signs of electrolytic conduction, and then test as to

* [Atom ?]

whether conductivity is increased by radiation with Röntgen rays. Experiments on liquid dielectrics should be easy enough. One of Röntgen's observations is of special importance. He found that air, through which Röntgen rays are passing, emits Röntgen rays; and this is exactly what our theory would indicate, because, as we saw in discussing reflexion, each atom scatters our small waves as a reflecting sphere distributes ordinary light.

The remaining important positive facts concerning Röntgen rays relate to their absorption in passing through different substances. Our short waves in passing through a unit cube of substance in a direction parallel to one of the edges, while passing along the molecular interspaces, will be falling at intervals directly on opposing surfaces of atoms; and if n be the number of atoms per unit volume, and R the radius of each, the quantity of surface encountered by unit area of wave-front will be proportional to $n^{\frac{2}{3}}R^2$, and the number of encounters in passing unit distance will be proportional to $n^{\frac{1}{3}}$, so that as regards amount of encounter of wave-front with atoms the energy absorbed by the atoms will be proportional to nR^2 . But if the effectiveness of a collision in causing absorption from a given area of wave-front in a given time is also proportional to the density of the matter in the atom, that is to m/R^3 , as we had to suppose in discussing the collisions of electrons and atoms, then the absorption of energy from our short waves in passage through unit length of different substances will be proportional to nm/R , that is to the density and inversely to atomic radius as with Lenard rays. The fact that Röntgen rays produce powerful fluorescence in certain substances shows that there are special resonance phenomena that must be expected to produce decided variations in absorption from the simple form just discussed; but the fact remains, as discovered by Röntgen, that by far the most important factor in the absorption of Röntgen rays is density. Benoist (*Compt. Rend.* cxxiv.) has found that the absorption of Röntgen rays by certain gases is proportional to the density, the factor of proportionality being nearly the same as for solids such as mica, phosphorus, and aluminium, though rising to a value six times as great in the case of platinum and palladium; density is the prevailing, but not the only, property which determines the absorption of the Röntgen rays. But under different circumstances Röntgen-ray apparatus gives out rays of very different absorbability, or, as it is usually expressed, of different penetrative power. Thomson's theory of the Röntgen rays, as thin electromagnetic pulses, does not seem to offer any feasible ex-

planation of this fundamental fact. The theory of vibrating electrons requires that, in addition to the fundamental mode of vibration, we must contemplate a number of harmonics associated with it; various combinations of fundamental and harmonics will be associated with different conditions of generation of the vibrations, and these will correspond to the Röntgen rays of different penetrative power.

An interesting observation of Swinton's, that two colliding cathode streams do not give rise to Röntgen rays, is explained by our hypothesis, because the electrons are so small and so far apart that an appreciable number of collisions between the electrons of two colliding streams cannot occur.

Some consequences of our line of reasoning, to which as yet no corresponding experimental results have been obtained, may now be indicated. The difference between cathode and anode is due to the fact that the attraction of metallic atoms for positive electrons is stronger than for negative ones, so that under a given electrical stress negative electrons break away as a cathode stream more easily than positive ones as an anode stream. But still, under strong enough electric stress at the anode, it ought to be possible to get an anode stream or anode rays similar to the cathode rays, but carrying positive electricity. These on encountering atoms, especially the atoms of a solid body, should cause the emission of rays similar to the Röntgen, but possibly very different in detailed properties, such as wave-length. It is possible that the Becquerel rays may be examples of what we may call positive Röntgen rays, because, while we have seen that, in the majority of cases, electrons move relatively to atoms in the production of light, in such a manner that they do not experience shocks throwing them into internal vibration, the uranium atom may be so formed that it periodically collides with its satellite electron or electrons, in which case the atoms of uranium would be a source of radiation analogous to the Röntgen.

According to our theory the velocity of the cathode stream is not a physical constant like the velocity of light through the æther, but ought to vary greatly according to the history of the stream, which starts with zero velocity and ends with the same. The velocity of the Röntgen rays should be of the order of that of light: we cannot assert that it should be exactly equal to that of light, because to waves of so short a length the neutrons may act as if they loaded the æther, so that Röntgen rays may suffer a refraction in æther in comparison with light. The fact that the experimental velocities found for the cathode rays are of the order of the velocity of

light is a striking one, to be compared with the fact that in the *vena contracta* of a gas escaping from an orifice the maximum velocity attainable is nearly that of the agitation of the average molecule in the containing vessel or of sound in the gas.

It appears as though a complete theory of electricity would be a kinetic theory, in which the place of the atoms or molecules of the kinetic theory of matter is taken by the electrons. The ion appears as a sort of molecule formed by the union of an atom or radical to an electron. But such large questions can hardly be opened up in the present connexion. We may summarize the contentions of the preceding pages in the two propositions:—

The cathode and Lenard rays are streams, not of ions, but of free negative electrons.

The Röntgen rays are caused by the internal vibrations of free electrons.

Melbourne, Nov. 1898.

XXI. *Properties of Liquid Mixtures.*—Part III.* *Partially Miscible Liquids.* By R. A. LEHFELDT, *D.Sc.*†

THE phenomena of complete mixture between two liquids, about which so little systematic knowledge is yet in existence, are connected with the phenomena of ordinary solution by an intermediate stage, that in which two liquids dissolve one another to a limited extent only. The study of such couples seems a promising field of investigation, on account of the intermediate position they occupy; it seems to offer the chance of extending some of the laws arrived at with regard to simple solution to the more complicated cases; I have therefore attempted to get some information on the equilibrium between incomplete mixtures and the vapour over them, and especially at the "critical point," *i. e.*, the point at which incomplete miscibility passes over into complete. A recent short paper by Ostwald ‡ draws attention to the importance of that point in the theory of mixtures.

Choice of Liquids.

The first point is to obtain suitable pairs of liquids for experiment. In order to study the properties of the critical point with ordinary vapour-pressure apparatus, it is necessary

* Part I. *Phil. Mag.* (5) xl. p. 398; Part II. *Phil. Mag.* (5) xlvi. p. 46; reprinted, *Proc. Phys. Soc.* xvi. p. 83.

† Communicated by the Physical Society: read Nov. 25, 1898.

‡ *Wied. Ann.* lxi. p. 336 (1897).

that the pressure at the critical point should be below one atmosphere, and that limits very much the choice of liquids. As a rule, two liquids either mix completely cold, or if they do not do that, raising to the boiling-point does not suffice to make them mix; two or three cases are all that I have been able to find in which the point of complete mixture can be arrived at by boiling, and consequently corresponds to a vapour-pressure below the atmospheric. Many other pairs of incompletely miscible liquids have been studied by Alexejew and others, but to arrive at their critical points it was necessary to raise them to a high temperature in sealed tubes. A recent paper by Victor Rothmund * contains new observations on the relation between concentration and temperature, including the concentration and temperature of the critical point, made by Alexejew's method. That paper contains a long account of previous work on the subject, which makes it the less necessary for me to go over the same ground. I will therefore mention only what has been done on vapour-pressures, as Rothmund does not touch on that side of the subject, merely adding two remarks to his paper. First, it does not seem to have been noticed that normal organic liquids always mix completely: I hoped to have found a normal pair to study first, in order to avoid the complication due to the abnormality supposed to be molecular aggregation in the liquid; I have not succeeded in finding such a pair. All the incompletely miscible pairs of liquids so far noted include water, methyl alcohol, or a low fatty acid as one member. To those with accessible critical points mentioned by Rothmund, I have only one pair to add, viz., ethylene dibromide and formic acid; these mix on boiling and separate into two layers when cold. I have not yet gone further with this couple; the vapour-pressure observations below refer to the well-known cases of phenol and water, aniline and water.

An account of previous experiments on the vapour-pressure of incompletely miscible liquids will indeed not take up much space, since, so far as I know, there is only one to record, viz., Konowalow's † measurements on isobutyl alcohol-water mixtures. His observations (made by a static method) give some points on the vapour-pressure curve up to 100° for (1) pure isobutyl alcohol (100 %); (2) mixtures containing 94.05 % and 6.17 %, both clear; (3) an undetermined mixture which separated into two layers. He unfortunately did not measure the solubility of the alcohol in water, or water in

* *Zeitschr. f. phys. Chem.* xxvi. p. 433 (1898).

† *Wied. Ann.* xiv. p. 43.

the alcohol, at any of the temperatures for which vapour-pressure observations are recorded, so those data have to be supplied from Alexejew's results *. Konowalow, in the second part † of his paper, proceeds to show that the possible forms of curve showing vapour-pressure against concentration (temperature constant) are two: (i.) the flat part of the curve bounded by a rising portion at one end and a falling portion at the other; (ii.) the flat part bounded by a falling portion at each end. Isobutyl alcohol-water mixtures give a curve of the latter kind.

Isobutyl alcohol and water, however, possess a critical point at about 130° , *i. e.*, much above the boiling-point of either. I therefore decided to study first mixtures of phenol and water, which become homogeneous in any proportions below 70° .

The phenol was a commercial "pure" specimen; to purify it further, it was placed in a distillation-flask and melted; then air was drawn through it for about half an hour, whilst its temperature was kept at about 160° to 170° , in order to dry it. It was then distilled, and by far the larger part came over between 178° and 180° . The fraction collected between $179^{\circ}5$ and 180° (about half the mass) was used in the experiments. To make up mixtures, the process always adopted was to warm the stoppered bottle containing the phenol to just above the melting-point, and pour the required amount into a weighing-flask. It was found that the moisture absorbed from the air during the process was quite inappreciable. The phenol, kept day after day at 40° to 50° ready for use, slowly turned pink, showing the presence of rosolic acid; but a comparative colour-observation showed that the amount of impurity was probably not more than $1/10,000$. When it was necessary to estimate phenol in a mixture, that was done by the method of Koppeschaar, tribromphenol being formed and the excess of bromine replaced by iodine and titrated with thiosulphate. The method gave quite satisfactory results.

Experimental Methods used.

The measurements on phenol-mixtures gave results contrary to my expectations, so that I became suspicious of the experimental methods. In the end I made use of four different kinds of apparatus, but found that they gave results in practical agreement, so that it became chiefly a question of convenience to decide between them.

* Wied. *Ann.* xxviii. p. 315.

† Wied. *Ann.* xiv. p. 222.

The first method tried was the "dynamic," carried out with the same apparatus as described in Part II. It required no modification, except the use of a new thermometer, since the old one did not go above 60° . The new thermometer was a longer one, graduated in $\frac{1}{5}$ from 0° to 100° (by C. E. Müller, No. 8). Its corrections were obtained in two ways: first by comparison with a standard (Reichsanstalt, 7347) at certain fixed temperatures, viz., the boiling-points of methyl acetate (57°), methyl alcohol (65°), and ethyl alcohol (78°); secondly, by measurements of the vapour-pressures of water under the same conditions as in the actual experiments; in these conditions part of the stem was exposed.

To use the apparatus the required mixture was weighed out from melted phenol and distilled water, then warmed up in the weighing-bottle until it became homogeneous, and poured into the tube of the vapour-pressure apparatus. The apparatus works satisfactorily except for mixtures on a very steep part of the curve of vapour-pressure (p) over concentration (z); when dp/dz is great, the change of composition of the liquid, due to the evaporation, becomes disproportionately important, and the static method is to be preferred; in the case of phenol mixtures, however, that only affects a small part of the range—mixtures with 90 per cent. or more of phenol.

The anomalous result that made me at first doubtful of the accuracy of the method was that up to 60 or 70 per cent. of phenol added to water made practically no difference to the vapour-pressure of the water. To check this, I made one or two experiments by the static method, in a barometer tube surrounded by an alcohol-vapour jacket of the usual pattern. They were not carried out with any attempt at accuracy, but sufficed to show that the previous observations could not be far wrong. The problem then was to determine the small difference in pressure between water and the phenol-water mixtures, and as for that purpose a differential gauge is obviously more appropriate, I set about designing and making the apparatus described below. Its design is based on a point of technique that does not seem to be much known, and to which, therefore, I should like to draw attention. If a glass tube be drawn out fine, sealed at one end, and evacuated, the sealed end may be broken under the surface of a liquid, which then flows in at any desired rate according to the diameter of the tube, and the tube may at any moment be fused off in the middle by a mouth blowpipe, without any inconvenience whatever. This process of filling with a liquid will I think be found advantageous in many cases. The only trouble about it is to get the capillary of the right bore;

since the rate of flow depends on the fourth power of the radius it is easy to make the tube too wide or too narrow. Of course I made a good many failures at first, but after some practice could rely on getting the required condition. I used tubing of about 1 millim. internal diameter, and 4 millim. external, and drew it out till the internal diameter was about one sixth of a millimetre ; a few centimetres of such a bore gives a convenient rate of flow for liquids of the viscosity of water.

Fig. 1.

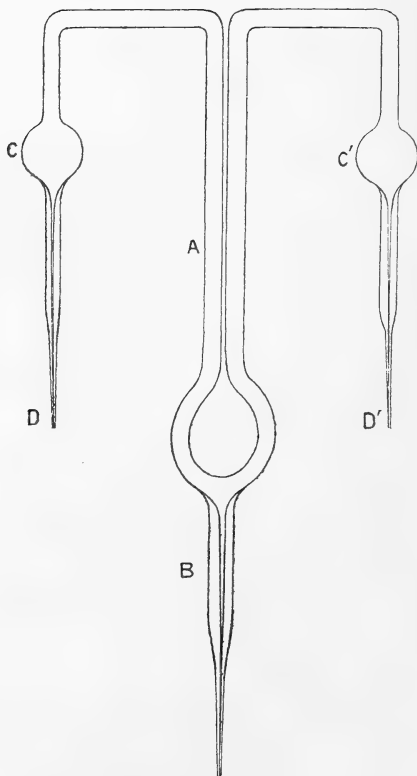

The apparatus for vapour-pressure measurements is shown in fig. 1. It consists of a U-tube, A, to serve as a gauge, carrying a branch, B, below, drawn out for filling as mentioned above. The top of the gauge-tube is bent round each side to the bulbs C, C', which are also provided with filling-tubes

D, D'. The whole is shown flat in the diagram ; but as a matter of fact the side tubes CD and C'D' were bent round till the bulbs nearly touched, to ensure their being of the same temperature. The apparatus was cleaned out with chromic acid, washed, and dried ; the capillaries were then drawn out and two of them sealed up, the third being left with the bit of wider tubing beyond the capillary untouched. By means of this it was attached to a mercury-pump, exhausted, and the capillary fused. The point B was then opened under mercury and fused off when the gauge contained sufficient : in the same way one of the bulbs was half filled with the mixture through D, and then the other with water (which must, of course, be freed from air) through D'. The apparatus, all of glass and hermetically sealed, is then ready for use : a glass millimetre scale is fastened with rubber bands to the gauge-tube, and it was immersed in a large glass jar of water. The scale was usually read by the telescope of a cathetometer and sometimes the screw micrometer of the telescope used to subdivide the graduation. The differential method avoids the necessity for any very great care in maintaining or measuring the temperature of the apparatus. It was found quite sufficient to heat the water-bath by leading a current of steam into it, and when the required temperature was reached, stop the steam for a moment and read the difference of level. When the highest temperature (90°) was reached, some of the water was siphoned off, replaced by cold, the whole mass well stirred, and a reading taken. There was no noticeable lag in the indications of the gauge, the readings at the same temperature, rising and falling, being in good agreement.

The fourth apparatus used was the Beckmann boiling-point apparatus, in its usual (second) form : with that observations at 100° were obtained of a kind to confirm the measurements made at somewhat lower temperatures with the vapour-pressure apparatus.

Observations of Vapour-pressure.

The following observations were obtained with the differential pressure-gauge : t is the temperature centigrade, p the vapour-pressure of the mixture, π that of water, $\pi - p$ is therefore the difference observed with the gauge, and $(\pi - p)/\pi$ represents the relative lowering of the vapour-pressure of water by the addition of the quantity of phenol mentioned.

Phenol-water Mixtures.

67·36 per cent. of phenol.

t	50°	65°	75°	85°	90°
$\pi-p$	0·5	0·4	2·2	5·6	8·2
$(\pi-p)/\pi$	0·005	0·002	0·008	0·013	0·015

77·82 per cent. of phenol.

t	70°	75°	80°	85°	90°
$\pi-p$	2·6	5·0	8·2	12·5	17·1
$(\pi-p)/\pi$	0·011	0·017	0·023	0·029	0·032

82·70 per cent. of phenol.

t	40°	50°	60°	65°	70°	75°	80°	85°	90°
$\pi-p$	1·4	5·6	11·1	14·8	19·2	25·2	32·2	42·3	53·9
$(\pi-p)/\pi$..	0·025	0·061	0·075	0·079	0·082	0·087	0·091	0·098	0·103

90·46 per cent. of phenol.

t	25°	40°	50°	60°	65°	70°	75°
$\pi-p$	1·9	9·1	17·5	31·7	43·2	53·5	68·6
$(\pi-p)/\pi$...	0·081	0·165	0·190	0·213	0·231	0·230	0·237

A mixture containing 7·74 per cent. of phenol gave no certain indication of a difference of pressure between the mixture and pure water. On this point, however, more reliable information is to be obtained with the Beckmann apparatus. It will be noticed from the preceding figures that the influence of the dissolved phenol becomes steadily greater as the temperature rises, *e. g.* 82 per cent. of phenol produces nearly twice as great a change of vapour-pressure proportionally at 90° as it does at 50°. In agreement with this the rise of vapour-pressures in dilute solutions of phenol is more marked at 100° than at the lower temperatures at which the vapour-pressure apparatus is available. The result of an experiment on the boiling-point is as follows:—

Per cent. phenol.	Fall of boiling-point.	Corresponding rise of vapour-pressure, $p-\pi$.
4·8	0·154	4·1
9·0	0·169	4·5
13·0	0·161	4·3
16·4	0·154	4·1

The general character of the results is sufficiently shown

by fig. 2, in which the isothermals of 90° and 75° are sufficiently represented. That of 90° is comparable with the curve

Fig. 2.—Isothermals of Phenol-Water Mixtures.

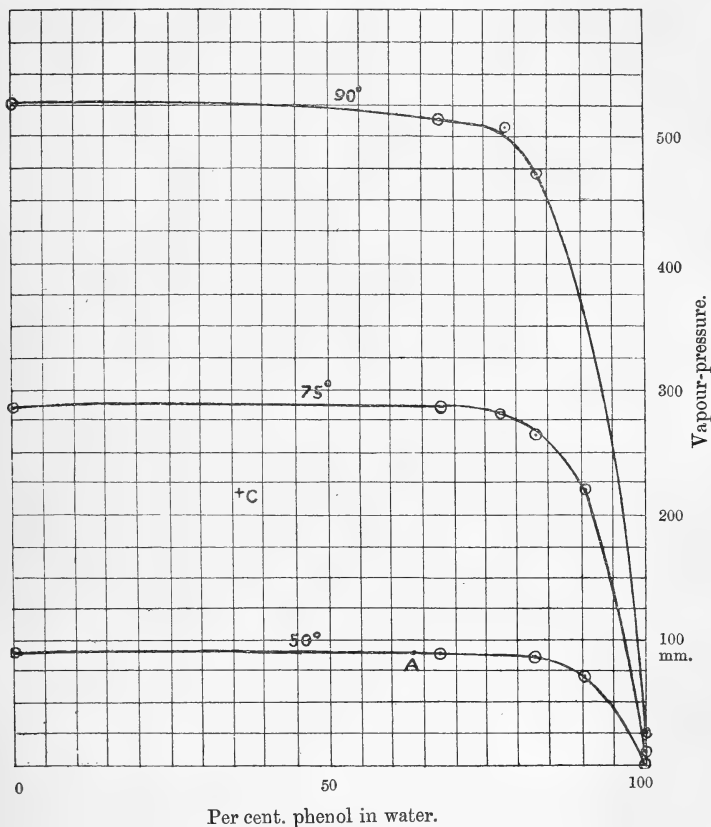

for alcohol-toluene mixtures (see fig. 2 in the preceding memoir), only that the flatness extending over a great part of the range of concentrations is exaggerated in the phenol-water mixtures. The curve for 75° —still above the critical point—is still flatter; indeed it is impossible to say whether it rises or falls. Probably, therefore, below the critical point (where the vapour-pressure of phenol is inconveniently small for measurement) the isothermal, instead of consisting of a horizontal line bounded by two curves, would consist of a horizontal passing through the point representing pure water, bounded at the other end only by a descending curve. Such

an isothermal—that of 50° —is shown in fig. 2. The horizontal part ends at the point A (63 per cent.), beyond which the mixtures are homogeneous: the curve beyond A may theoretically meet the horizontal line at a finite angle, but that is certainly not distinguishable on the diagram. The curve is in fact exactly similar, so far as the experiments show, to that for 75° , and the pressure of the critical point, C on the diagram, which lies between them (at $68^{\circ}\cdot4$) appears to make no difference whatever in this case—a case of great disparity in the vapour-pressures of the two components.

For comparison, a few experiments were made with aniline (not specially purified) and water. A mixture which consisted of two layers, even at the highest temperature used in the experiment, gave in the differential apparatus the following results:—

t	70°	80°	85°
$\pi - p$	-6.8	-11.1	-13.3
$(\pi - p)/\pi$...	-0.0290	-0.0315	-0.0307

Whilst the Beckmann apparatus gave at 100° :—

Per cent. aniline.	Lowering of boiling-point.	$\pi - p$.	$\frac{\pi - p}{\pi}$.
3.99	0.636	-17.1	0.0225
7.68	0.921	-24.6	0.0324
11.10	0.921	-24.6	0.0324

The second column gives the observed fall in temperature on adding aniline to the water; the third column the rise of pressure corresponding, at the rate of 26.8 millim. per degree. Water at 100° is saturated by the addition of 6.5 per cent. of aniline, and it will be seen that the vapour-pressure rises no further after that. The relative rise of vapour-pressure on saturation is 0.0324 at 100° , in satisfactory agreement with the numbers obtained by the differential gauge (0.0290, 0.0315, 0.0307), a tendency to increase with temperature being distinguishable here, as with phenol. Now suppose the vapour-pressure of a saturated mixture to be obtained in this way: let the partial pressure of the water-vapour be that of pure water reduced by the normal amount (Raoult's law) due to the solution in it of the maximum quantity of aniline: and let the partial pressure of aniline-vapour be that of pure aniline reduced by the normal amount due to the

solution in it of the maximum quantity of water. We get the following results at 100°:—

- Vapour-pressure of water = 760 millim.
 Solubility of aniline = 6·5 per cent. = 1·32 molecular per cent.
 Partial pressure of water = 98·68 per cent. of 760 = 749·9 millim.
 Vapour-pressure of aniline = 46 millim.*
 Solubility of water in aniline = 8·7 per cent. = 33 molecular per cent. (Alexejew).
 Partial pressure of aniline = 30·8.
 Total pressure = 749·9 + 30·8 = 780·7.
 Observed pressure = 784·6 millim.

The vapour-pressure of the saturated mixture is therefore given fairly well by the above rule. The rule cannot be applied to phenol mixtures, as below the critical point the vapour-pressure of phenol is too low to determine with accuracy. Konowalow's measurements of the vapour-pressure of isobutyl alcohol-water mixtures, combined with Alexejew's measurements of solubility, give the following results. At 90°:—

- Vapour-pressure of water = 525 millim.
 Solubility of isobutyl alcohol = 7 per cent. = 1·8 molecular per cent.
 Partial pressure of water-vapour = 98·2 per cent. of 525 = 515·5.
 Vapour-pressure of isobutyl alcohol = 378 millim.
 Solubility of water = 25 per cent. = 57·8 molecular per cent.
 Partial pressure of isobutyl alcohol = 159·5.
 Sum = 675·1.
 Observed pressure = 767.

In this case the alcohol saturated with water contains more molecules of water than of alcohol, and it is not to be expected that the normal depression of the vapour-pressure should hold over so wide a range as 57·8 per cent. The numbers in fact show that the partial pressure of isobutyl alcohol must be very much greater—about 250 millim. The curve of partial pressures is therefore comparable with that for ethyl alcohol in benzene and toluene (see Part II. tables p. 53).

* Kahlbaum, *Zeitsch. f. phys. Chem.* xxvi. p. 604.

Characteristic Surface for Phenol-Water Mixtures.

To complete an account of the behaviour of phenol-water mixtures, it is necessary to draw a diagram of the relations between temperature and concentration; this is given in fig. 3. Figs. 2 and 3 together, therefore, give a notion of the shape of the "characteristic surface," *i. e.* the surface showing the relations between concentration, temperature, and pressure. Fig. 2 contains three sections at right angles to the axis of

Fig. 3.

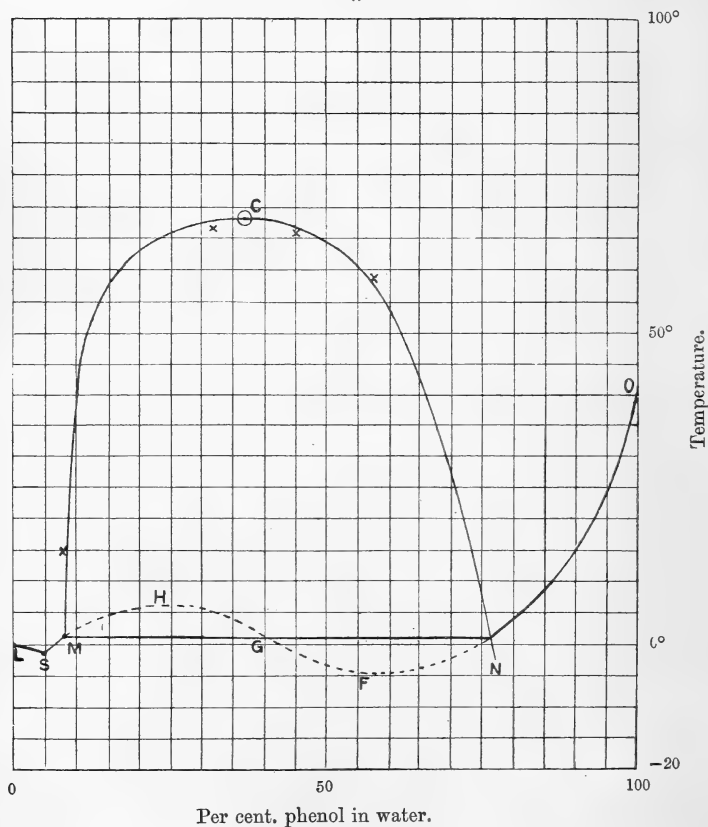

temperature (for $T=90^\circ$, $T=75^\circ$, $T=50^\circ$ respectively), while fig. 3 gives one section at right angles to the axis of pressure ($p=1$ atmo).

The behaviour of phenol-water mixtures is formally

identical with that of benzoic acid and water *, but the curve branches of the diagram are of very different relative sizes to those of the last-named mixtures. The features of the diagram are as follows :—

- L. Freezing-point of water.
- O. Freezing-point of phenol.
- LS. Freezing-point of aqueous solutions of phenol.
- ONFGHMS. Freezing-point of solutions of water in phenol.
- S. Cryohydric point.
- MC. Saturation of water with phenol.
- NC. Saturation of (liquid) phenol with water.
- C. Critical point of mixture.

The line LS is given by the thermodynamic equation

$$t = \frac{0.02T^2}{L}$$

where T is the absolute temperature of fusion of ice, L the latent heat of fusion, and t the resulting molecular depression of the freezing-point; it accordingly starts with a slope of 0°·2 for one per cent. of phenol. The initial slope of ON is given by a similar equation, and is 4°·15 for one per cent. of water; a direct observation gave as a point of the curve

80·5 per cent. phenol,
melting-point + 5·0.

This is marked with a dot in the figure, and lies to the right of CN; by continuing the curve through the point so found until CN is met, we reach the point N where the phenol is saturated with water; on increasing the concentration a second liquid layer appears, consisting of water saturated with phenol. NFGHM is purely hypothetical, referring to unstable mixtures; actually any mixture of concentration between 8 per cent. and 77 per cent. of phenol will separate into two layers on cooling, and on further reduction of temperature freeze at the constant temperature (about +1°·5) represented by the horizontal straight line MN. The cryohydric point lies to the left of the saturation curve CM, so that it is actually attainable: its existence was shown by making a solution containing 5·25 per cent. of phenol, and cooling it in a bath of ice and salt: it began to freeze without previous separation into two layers, and the temperature remained constant at -0°·9. About half of it was frozen, the beaker removed from the freezing-mixture, and some of the liquid remaining poured off for analysis; it was found to

* See van't Hoff, *Vorlesungen über theoretische und physikalische Chemie*, Heft i. p. 48. (Braunschweig, 1898.)

contain 4·83 per cent. phenol : this concentration is therefore in equilibrium with both ice and solid phenol which had been deposited on the sides of the beaker. The cryohydric mixture therefore contains so little phenol that it may be looked upon as a dilute solution of phenol in water, and its calculated freezing-point, according to van't Hoff's rule, would be $-1^{\circ}0$, in agreement with the observed value $-0^{\circ}9$. Consequently solutions of strength between M and S will deposit phenol on cooling, those between L and S (0 to 4·83 per cent.) ice.

The diagram is completed by the curve MCN which is drawn from Rothmund's observations*, which are indicated by dots ; my own observations (shown by crosses) are in practical agreement with his and Alexejew's.

Finally, the curves divide the diagram into regions, with the following meanings :—

Below LS undercooled solutions of phenol, from which ice crystallizes out, with formation of the saturated solutions LS.

Below SMNO supersaturated solutions of phenol, from which phenol crystallizes out with formation of the saturated solutions of phenol in water (SM) and water in phenol (NO).

MCNGM, unstable mixtures which separate into the two saturated solutions CM and CN, forming two liquid layers.

Above LSMCNO homogeneous liquid mixtures.

The Davy-Faraday Research Laboratory, Royal Institution,
London, October, 1898.

XXII. *On the Propagation of Damped Electrical Oscillations along Parallel Wires.* By W. B. MORTON, M.A.†

IN a paper published in the Philosophical Magazine for September 1898 Dr. E. H. Barton has compared the attenuation of electrical waves in their passage along parallel wires, as experimentally determined by him, with the formula given by Mr. Heaviside in his theory of long waves. The results show a large discrepancy between the theory and the experiments, the observed value of the attenuation constant being about twice too large. Dr. Barton discusses several possible causes of error and finds them inadequate, and suggests that the reason of the difference may lie either in (1) the nearness of the wires to one another, or (2) in the damping of the wave-train propagated by the oscillator. To these may be added (3) the consideration that the formulæ used were deduced by Mr. Heaviside from the discussion of his "distortionless circuit," in which the matter is simplified

* *L. c.* p. 452.

† Communicated by the Physical Society : read Nov. 11, 1898.

by supposing sufficient leakage to counteract the distortion produced by the resistance of the leads, whereas in Dr. Barton's circuit the leakage was negligible.

It is probable that the nearness of the wires has an appreciable effect on the phenomenon. The discrepancy would be diminished if the actual resistance of the wires was greater than that calculated by Dr. Barton from Lord Rayleigh's high-frequency formula. Now the effect of the neighbourhood of two wires carrying rapidly oscillating currents in opposite directions is to make the currents concentrate towards the inner sides of the wires*; and this would cause an increase in the effective resistance.

I have examined the effects of (2) and (3), viz. of the damping and the want of balance in the constants of the circuit. The investigation is perhaps of some interest owing to the fact that these elements are always present in the ordinary experimental conditions; although, as will be seen, we are led to the conclusion that in all actual cases their influence on the phenomena is of quite negligible order. The method is the same as that used by Mr. Heaviside.

General Theory.—Let the inductance of the circuit be L , its capacity S , its resistance (of double wires) R , and its leakage-conductance K , all per unit length. An important part is played by the ratios $\frac{R}{L}$ and $\frac{K}{S}$; we shall call these ρ and σ . When ρ and σ are equal we have the "distortionless" circuit above referred to.

Now if V be the difference of potential between the wires and C the current in the positive wire, we have the equations

$$-\frac{dV}{dz} = \left(R + L \frac{d}{dt} \right) C, \quad \dots \dots \dots (1)$$

$$-\frac{dC}{dz} = \left(K + S \frac{d}{dt} \right) V; \quad \dots \dots \dots (2)$$

giving

$$\begin{aligned} \frac{d^2V}{dz^2} &= \left(R + L \frac{d}{dt} \right) \left(K + S \frac{d}{dt} \right) V \\ &= \frac{1}{v^2} \left(\rho + \frac{d}{dt} \right) \left(\sigma + \frac{d}{dt} \right) V, \quad \dots \dots \dots (3) \end{aligned}$$

since $LSv^2=1$, where v is the velocity of radiation.

To simplify the algebra we shall work first with $V = V_0 e^{-mz+nt}$,

* Cf. J. J. Thomson, 'Recent Researches,' p. 511.

which can be made to represent damped periodic vibrations by giving complex values to m and n .

The equation (3) now becomes

$$m^2v^2 = (\rho + n)(\sigma + n); \quad \dots \dots \dots (4)$$

and the connexion between C and V is given by (1), viz.

$$C = \frac{mV}{R + Ln}. \quad \dots \dots \dots (5)$$

To find the effect of a pure resistance R' between the ends of the wires, as in Dr. Barton's experiments, put V_1, V_2, C_1, C_2 for the potentials and currents in the incident and reflected waves respectively. Then we have

$$C_1 = \frac{mV_1}{R + Ln}, \quad C_2 = \frac{-mV_2}{R + Ln};$$

also the total potential-difference $V_1 + V_2$ is connected with total current $C_1 + C_2$ through resistance R' by Ohm's law,

$$V_1 + V_2 = R'(C_1 + C_2).$$

These equations give for the reflexion factor

$$\frac{V_2}{V_1} = - \frac{R + Ln - mR'}{R + Ln + mR'}. \quad \dots \dots \dots (6)$$

If the circuit be distortionless and $R' = Lv$, then, as Mr. Heaviside showed, the absorption of the waves by the terminal resistance will be complete. We may regard this as the critical resistance for the circuit, and we shall express R' in terms of it by putting $R' = xLv$. We then have

$$\frac{V_2}{V_1} = - \frac{\rho + n - mvx}{\rho + n + mvx}. \quad \dots \dots \dots (7)$$

Damped Wave-Train.—To pass to the case of a damped train transmitted from the origin in the positive direction of z we put

$$m = -\beta + i\alpha, \quad n = -q + ip.$$

The difference of potential between the wires at any point after the head of the wave-train has reached this point is then represented by an expression of the form

$$V_0 e^{\beta z - qt} \sin(pt - \alpha z).$$

The velocity of propagation is $\frac{p}{\alpha}$, the frequency $\frac{p}{2\pi}$, the logarithmic decrement $\frac{2\pi q}{p}$. If the waves suffered no attenu-

ation in their passage along the leads we should have

$$\beta z - qt = 0 \text{ when } z = \frac{pt}{\alpha}, \text{ i. e. } \beta = \frac{q\alpha}{p}.$$

In general, it is plain that $\left(\frac{q\alpha}{p} - \beta\right)$ measures the attenuation.

Inserting the complex variables in equation (4) we have

$$v^2(\beta - i\alpha)^2 = (\rho - q + ip)(\sigma - q + ip);$$

$$\therefore v^2(\beta^2 - \alpha^2) = q^2 - p^2 - q(\rho + \sigma) + \rho\sigma; \dots \dots \dots (8)$$

and

$$2v^2\alpha\beta = p(2q - \rho - \sigma); \dots \dots \dots (9)$$

whence

$$v^2(\beta^2 + \alpha^2) = \sqrt{\{p^2 + (q - \rho)^2\}\{p^2 + (q - \sigma)^2\}}. \dots (10)$$

Velocity of Propagation and Attenuation.—In actual cases ρ and σ are small compared with p . If the damping is considerable, q may be comparable with p . Accordingly we expand the right-hand side of (10) in ascending powers of ρ and σ and solve for $v\alpha$ and $v\beta$. As far as terms of the third order in ρ and σ we find

$$v^2\alpha = p + \frac{p(\rho - \sigma)^2}{8(p^2 + q^2)} + \frac{pq(\rho + \sigma)(\rho - \sigma)^2}{8(p^2 + q^2)^2} + \dots, \dots (11)$$

$$v\beta = q - \frac{1}{2}(\rho + \sigma) - \frac{q(\rho - \sigma)^2}{8(p^2 + q^2)} + \frac{(p^2 - q^2)(\rho + \sigma)(\rho - \sigma)^2}{16(p^2 + q^2)^2} + \dots \dots (12)$$

Hence the *velocity of propagation*

$$= \frac{p}{\alpha} = v \left[1 - \frac{(\rho - \sigma)^2}{8(p^2 + q^2)} - \frac{q(\rho + \sigma)(\rho - \sigma)^2}{8(p^2 + q^2)^2} - \dots \right], \dots (13)$$

and the *attenuation*

$$= \frac{q\alpha}{p} - \beta = \frac{1}{v} \left[\frac{\rho + \sigma}{2} + \frac{q(\rho - \sigma)^2}{4(p^2 + q^2)} + \frac{(3q^2 - p^2)(\rho + \sigma)(\rho - \sigma)^2}{16(p^2 + q^2)^2} + \dots \right]. (14)$$

If $\rho = \sigma$, there is no distortion, the velocity of propagation is v , and the attenuation is $\frac{R}{Lv}$ or $\frac{K}{Sv}$ for all frequencies; and the damping has no effect on these quantities.

We have an interesting particular case when $\rho = \sigma = q$. Then $\beta = 0$, and the state of affairs is given by

$$V = V_0 e^{-qt} \sin\left(pt - \frac{z}{v}\right).$$

Here the damping and the attenuation are balanced, so that

the wave-train in the wires is at any instant *purely* simple harmonic throughout.

Numerical Values.—To obtain an estimate of the importance of the small terms of (13) and (14) I shall take the numbers given by Dr. Barton in his last paper (*loc. cit.*). Judging from his diagram (fig. 2) in that paper, the amplitude of the second positive maximum of the wave-train is about half that of the first. This would give

$$e^{\frac{2\pi q}{p}} = 2 \quad \text{or} \quad q = \frac{p \log_e 2}{2\pi}.$$

We have roughly

$$p = 2\pi \times 35 \times 10^6 = 22 \times 10^7, \quad q = 24 \times 10^6,$$

$$R = 69.5 \times 10^5, \quad L = 19;$$

$$\therefore \rho = 37 \times 10^4, \quad \text{and} \quad \sigma = 0.$$

These values give for the velocity of propagation

$$v \{1 - .00000035\},$$

and for the attenuation

$$\frac{R}{2Lv} \{1 + .000091\},$$

so that the corrections are quite negligible. We see from the expressions (13), (14) that the damping q only affects the value of the small terms introduced by the inequality of ρ and σ .

Effect of a Terminal Resistance.—To find the effect on the incident waves of a resistance (without inductance) inserted between the ends of the wires, we put in the complex values in the expression (7) for the reflexion-factor. We then get

$$\begin{aligned} \frac{V_2}{V_1} &= \frac{(\rho - q + v\beta x) + i(p - v\alpha x)}{(-\rho + q + v\beta x) - i(p + v\alpha x)} \\ &= f + ig, \text{ say.} \end{aligned}$$

Therefore to an incident wave e^{ipt} corresponds a reflected wave $(f + ig)e^{ipt}$; or, taking real parts, with incident $\cos pt$ we have reflected

$$f \cos pt - g \sin pt = \sqrt{f^2 + g^2} \cos (pt + \theta),$$

where

$$\tan \theta = \frac{g}{f};$$

so that the change of amplitude is accompanied by a change of phase.

The values come out

$$f^2 + g^2 = \frac{(\rho - q + v\beta x)^2 + (p - v\alpha x)^2}{(-\rho + q + v\beta x)^2 + (p + v\alpha x)^2} \dots \dots \dots (15)$$

$$= \frac{x^2 v^2 (\alpha^2 + \beta^2) - 2xv \{ \beta(q - \rho) + \alpha p \} + (q - \rho)^2 + p^2}{x^2 v^2 (\alpha^2 + \beta^2) + 2xv \{ \beta(q - \rho) + \alpha p \} + (q - \rho)^2 + p^2} \dots (16)$$

$$\frac{g}{f} = \frac{2xv \{ \beta p - \alpha(q - \rho) \}}{x^2 v^2 (\alpha^2 + \beta^2) - (q - \rho)^2 - p^2} \dots \dots \dots (17)$$

In order that there should be complete absorption of the incident waves it is necessary that the two squares in the numerator of (15) should vanish separately. This requires

$$\frac{v\alpha}{p} = \frac{v\beta}{q - \rho} = \lambda, \text{ say.}$$

If we substitute $v\alpha = p\lambda$ and $v\beta = (q - \rho)\lambda$ in equations (8) and (9), and eliminate λ by division, we find the condition reduces to

$$(\rho - \sigma) \{ (q - \rho)^2 + p^2 \} = 0, \quad \therefore \rho = \sigma.$$

Therefore complete absorption is only attainable in the distortionless case. In general we can only reduce the reflected amplitude to a minimum.

We can write (16) and (17) in the forms

$$f^2 + g^2 = \frac{ax^2 - 2hx + b}{ax^2 + 2hx + b} \dots \dots \dots (18)$$

$$\tan \theta = \frac{g}{f} = \frac{2x \sqrt{ab - h^2}}{ax^2 - b} \dots \dots \dots (19)$$

From (18) we see that to any value of reflected amplitude correspond two values of the terminal resistance, say x_1, x_2 . We can show that the corresponding phase-differences θ_1, θ_2 are supplementary.

For from (18) we have

$$x_1 x_2 = \frac{b}{a};$$

$$\begin{aligned} \therefore \tan \theta_1 + \tan \theta_2 &= 2 \sqrt{ab - h^2} \left[\frac{x_1}{ax_1^2 - b} + \frac{x_2}{ax_2^2 - b} \right] \\ &= 2 \sqrt{ab - h^2} \frac{(x_1 + x_2)(ax_1 x_2 - b)}{(ax_1^2 - b)(ax_2^2 - b)} = 0. \end{aligned}$$

The minimum reflected amplitude is got when

$$x_1 = x_2 = \sqrt{\frac{b}{a}}$$

The reflexion-factor is then $\frac{\sqrt{ab} - h}{\sqrt{ab} + h}$, and the phase-difference is $\frac{\pi}{2}$. When $x=0$ we have complete reflexion with unaltered

phase; with $x=\infty$, or the circuit open, we have complete reflexion with reversed phase. The simultaneous alteration of amplitude and phase-difference brings it about that we appear to pass continuously from amplitude $+1$ ($x=0$) to amplitude -1 ($x=\infty$) without passing through amplitude zero. This apparent anomaly was pointed out to me by Dr. Barton. Putting in the values of a , b , h , and substituting for $v\alpha$ and $v\beta$ approximate values from (11), (12), we find that the minimum value of the reflexion-factor $\sqrt{f^2 + g^2}$ is

$$\frac{p(\rho - \sigma)}{4(p^2 + q^2)},$$

and that the corresponding value of x is

$$1 - \frac{q(\rho - \sigma)}{2(p^2 + q^2)},$$

neglecting higher terms in $\rho\sigma$.

Numerical Values.—Again using Dr. Barton's numbers we get for the minimum reflexion-factor the value $\cdot 0004$, and for the corresponding terminal resistance $Lv(1 + \cdot 00009)$. (If, therefore, the terminal resistance be adjusted until the reflected wave is a minimum, we may, without sensible error, take this resistance to be Lv , and ignore the reflected train altogether.

Queen's College, Belfast,
13th October, 1898.

XXIII. *Application of Sellmeier's Dynamical Theory to the Dark Lines D₁, D₂ produced by Sodium-Vapour.* By Lord KELVIN, G.C.V.O., P.R.S.E.*

§ 1. **F**OR a perfectly definite mechanical representation of Sellmeier's theory, imagine for each molecule of sodium-vapour a spherical hollow in ether, lined with a thin rigid spherical shell, of mass equal to the mass of homogeneous ether which would fill the hollow. This rigid lining

* Communicated by the Author, having been read before the Royal Society of Edinburgh on Feb. 6, 1899.

of the hollow we shall call the sheath of the molecule, or briefly the sheath. Within this put two rigid spherical shells, one inside the other, each movable and each repelled from the sheath with forces, or distribution of force, such that the centre of each is attracted towards the centre of the hollow with a force varying directly as the distance. These suppositions merely put two of Sellmeier's single-atom vibrators into one sheath.

§ 2. Imagine now a vast number of these diatomic molecules, equal and similar in every respect, to be distributed homogeneously through all the ether which we have to consider as containing sodium-vapour. In the first place, let the density of the vapour be so small that the distance between nearest centres is great in comparison with the diameter of each molecule. And in the first place also, let us consider light whose wave-length is very large in comparison with the distance from centre to centre of nearest molecules. Subject to these conditions we have (Sellmeier's formula)

$$\left(\frac{v_e}{v_s}\right)^2 = 1 + \frac{m\tau^2}{\tau^2 - \kappa^2} + \frac{m_i\tau^2}{\tau^2 - \kappa_i^2} \quad \dots \quad (1);$$

where m, m_i denote the ratios of the sums of the masses of one and the other of the movable shells of the diatomic molecules in any large volume of ether, to the mass of undisturbed ether filling the same volume; κ, κ_i the periods of vibration of one and the other of the two movable shells of one molecule, on the supposition that the sheath is held fixed; v_e the velocity of light in pure undisturbed ether; v_s the velocity of light of period τ in the sodium-vapour.

§ 3. For sodium-vapour, according to the measurements of Rowland and Bell*, published in 1887 and 1888 (probably the most accurate hitherto made), the periods of light corresponding to the exceedingly fine *dark* lines D_1, D_2 of the solar spectrum are $\cdot 589618$ and $\cdot 589022$ of a micron†. The mean of these is so nearly one thousand times their difference that we may take

$$\kappa = \frac{1}{2}(\kappa + \kappa_i) \left(1 - \frac{1}{2000}\right); \quad \kappa_i = \frac{1}{2}(\kappa + \kappa_i) \left(1 + \frac{1}{2000}\right) \quad (2).$$

* Rowland, Phil. Mag. 1887, first half-year; Bell, Phil. Mag. 1888, first half-year.

† "Michron" is the name which I have given to a special unit of time such that the velocity of light is one mikrom of space per micron of time, the mikrom being one millionth of a metre. The best determinations of the velocity of light in undisturbed ether give 300,000 kilometres, or 3×10^{14} mikroms, per second. This makes the micron $\frac{1}{3} \times 10^{-14}$ of a second.

Hence if we put

$$\tau = \frac{1}{2}(\kappa + \kappa_j) \left(1 + \frac{x}{1000}\right) \dots \dots \dots (3);$$

and if x be any numeric not exceeding 4 or 5 or 10, we have

$$\left(\frac{\kappa}{\tau}\right) \doteq 1 - \frac{1}{1000}(2x+1); \quad \left(\frac{\kappa_j}{\tau}\right)^2 \doteq 1 - \frac{1}{1000}(2x-1) \dots (4);$$

whence

$$\frac{\tau^2}{\tau^2 - \kappa^2} \doteq \frac{1000}{2x+1}; \quad \frac{\tau^2}{\tau^2 - \kappa_j^2} \doteq \frac{1000}{2x-1} \dots \dots \dots (5).$$

Using this in (1), and denoting by μ the refractive index from ether to an ideal sodium-vapour with only the two disturbing atoms m, m_j , we find

$$\left(\frac{v_e}{v_s}\right)^2 = \mu^2 = 1 + \frac{1000m}{2x+1} + \frac{1000m_j}{2x-1} \dots \dots \dots (6).$$

§ 4. When the period, and the corresponding value of x according to (3), is such as to make μ^2 negative, the light cannot enter the sodium-vapour. When the period is such as to make μ^2 real, the proportion (according to Fresnel, and according to the most probable dynamics,) of normally incident light which enters the vapour is

$$1 - \left(\frac{\mu-1}{\mu+1}\right)^2 \dots \dots \dots (7).$$

§ 5. Judging from the approximate equality in intensity of the bright lines D_1, D_2 of incandescent sodium-vapour; and from the approximately equal strengths of the very fine dark lines D_1, D_2 of the solar spectrum; and from the approximately equal strengths, or equal breadths, of the dark lines D_1, D_2 observed in the analysis of the light of an incandescent metal, or of the electric arc, seen through sodium-vapour of insufficient density to give much broadening of either line; we see that m and m_j cannot be very different, and we have as yet no experimental knowledge to show that either is greater than the other. I have therefore assumed them equal in the calculations and numerical illustrations described below.

§ 6. At the beginning of the present year I had the great pleasure to receive from Professor Henri Becquerel, enclosed with a letter of date Dec. 31, 1898, two photographs of ano-

malous dispersion by prisms of sodium-vapour*, by which I was astonished and delighted to see not merely a beautiful and perfect demonstration of the "anomalous dispersion" towards infinity on each side of the zero of refractivity, but also an illustration of the characteristic nullity of absorption and finite breadth of dark lines, originally shown in Sellmeier's formula † of 1872 and now, after 27 years, first actually seen. Each photograph showed dark spaces on the high sides of the D_1, D_2 lines, very narrow on one of the photographs; on the other much broader, and the one beside the D_2 line decidedly broader than the one beside the D_1 line; just as it should be according to Sellmeier's formula, according to which also the density of the vapour in the prism must have been greater in the latter case than in the former. Guessing from the ratio of the breadths of the dark bands to the space between their D_1, D_2 borders, and from a slightly greater breadth of the one beside D_2 , I judged that m must in this case have been not very different from .0002; and I calculated accordingly from (6) the accompanying graphical representation showing the value of $1 - \frac{1}{\mu}$, represented by y in fig. 1.

Fig. 1.

$m = .0002$.

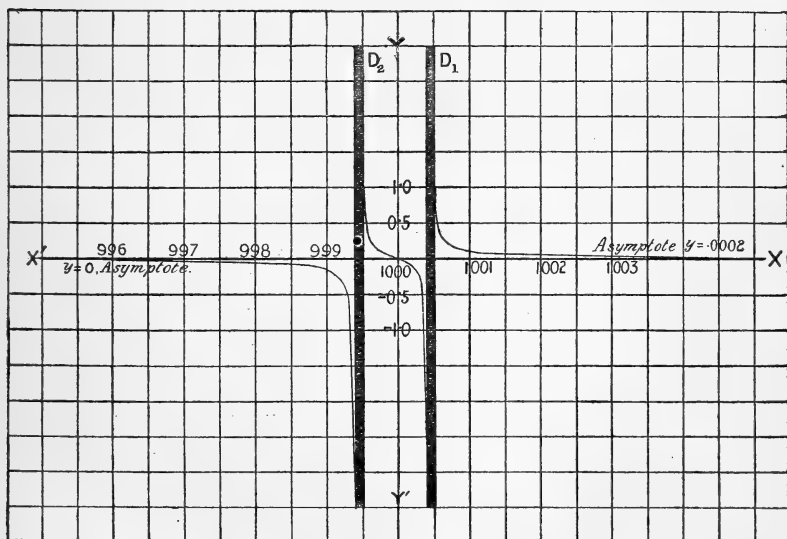

* A description of Professor Becquerel's experiments and results will be found in *Comptes Rendus*, Dec. 5, 1898, and Jan. 16, 1899.

† Sellmeier, *Pogg. Ann.* vol. cxlv. (1872) pp. 399, 520; vol. cxlvii. (1872) pp. 387, 525.

Fig. 2 represents similarly the value of $1 - \frac{1}{\mu}$ for $m = \cdot 001$, or density of vapour five times that in the case represented

Fig. 2.

$m = \cdot 001$.

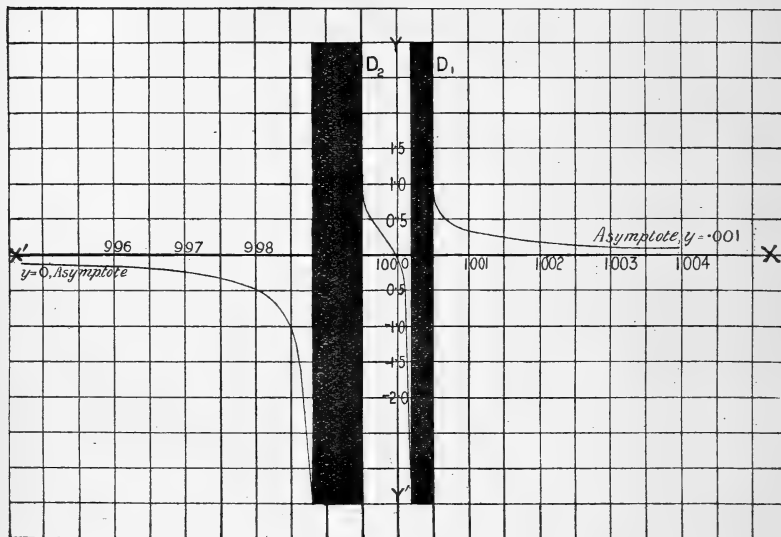

Fig. 3.

$m = \cdot 0002$.

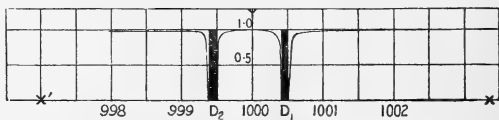

Fig. 4.

$m = \cdot 001$.

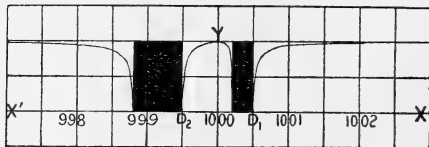
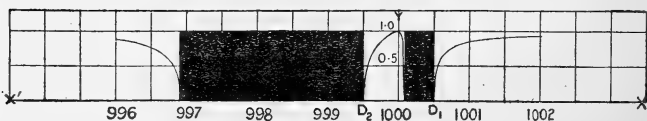

Fig. 5.

$m = \cdot 003$.



by fig. 1. Figs. 3 and 4 represent the ratio of intensities of transmitted to normally incident light for the densities corresponding to figs. 1 and 2; and fig. 5 represents the ratio for

the density corresponding to the value $m = \cdot 003$. The following table gives the breadths of the dark bands for densities of vapour corresponding to values of m from $\cdot 0002$ to fifteen times that value; and fig. 6 represents graphically the breadths of the dark bands and their positions relatively to the bright lines D_1 , D_2 for the first five values of m in the table.

Values of m .	Breadths of Bands.	
	D_1 .	D_2 .
$\cdot 0002$	$\cdot 09$	$\cdot 11$
$\cdot 0006$	$\cdot 217$	$\cdot 383$
$\cdot 0010$	$\cdot 293$	$\cdot 707$
$\cdot 0014$	$\cdot 340$	$1\cdot 060$
$\cdot 0018$	$\cdot 371$	$1\cdot 429$
$\cdot 0022$	$\cdot 392$	$1\cdot 808$
$\cdot 0026$	$\cdot 408$	$2\cdot 192$
$\cdot 0030$	$\cdot 419$	$2\cdot 581$

Fig. 6.

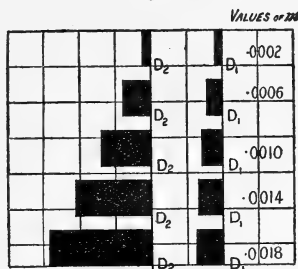

§ 7. According to Sellmeier's formula the light transmitted through a layer of sodium-vapour (or any transparent substance to which the formula is applicable) is the same whatever be the thickness of the layer (provided of course that the thickness is at least several wave-lengths, and that the ordinary theory of the transmission of light through thin plates is taken into account when necessary). Thus the D_1 , D_2 lines of the spectrum of solar light, which has travelled from the source through a hundred kilometres of sodium-vapour in the sun's atmosphere, must be identical in breadth and penumbras with those seen in a laboratory experiment in the spectrum of

light transmitted through half a centimetre or a few centimetres of sodium-vapour, of the same density as the densest part of the sodium-vapour in the portion of the solar atmosphere traversed by the light analysed in any particular observation. The question of temperature cannot occur except in so far as the density of the vapour, and the clustering in groups of atoms, or non-clustering (mist or vapour of sodium), are concerned.

§ 8. A grand inference from the experimental foundation of Stokes' and Kirchoff's original idea is that the periods of molecular vibration are the same to an exceedingly minute degree of accuracy through the great differences of range of vibration presented in the radiant molecules of an electric spark, electric arc, or flame, and in the molecules of a comparatively cool vapour or gas giving dark lines in the spectrum of light transmitted through it.

§ 9. It is much to be desired that laboratory experiments be made, notwithstanding their extreme difficulty, to determine the density and pressure of sodium-vapour through a wide range of temperature, and the relation between density, pressure, and temperature of gaseous sodium.

XXIV. *On the Cooling of Air by Radiation and Conduction, and on the Propagation of Sound.* By LORD RAYLEIGH, F.R.S.*

ACCORDING to Laplace's theory of the propagation of Sound the expansions (and contractions) of the air are supposed to take place without transfer of heat. Many years ago Sir G. Stokes † discussed the question of the influence of radiation from the heated air upon the propagation of sound. He showed that such small radiating power as is admissible would tell rather upon the intensity than upon the velocity. If x be measured in the direction of propagation, the factor expressing the diminution of amplitude is e^{-mx} , where

$$m = \frac{\gamma - 1}{\gamma} \frac{q}{2a} \dots \dots \dots (1)$$

In (1) γ represents the ratio of specific heats (1.41), a is the velocity of sound, and q is such that e^{-qt} represents the law of cooling by radiation of a small mass of air maintained at constant volume. If τ denote the time required to traverse the distance x , $\tau = x/a$, and (1) may be taken to assert that the amplitude falls to any fraction, $e.g.$ one-half, of its original

* Communicated by the Author.

† Phil. Mag. [4] i. p. 305, 1851; Theory of Sound, § 247.

value in 7 times the interval of time required by a mass of air to cool to the same fraction of its original excess of temperature. "There appear to be no data by which the latter interval can be fixed with any approach to precision; but if we take it at one minute, the conclusion is that sound would be propagated for (seven) minutes, or travel over about (80) miles, without very serious loss from this cause"*. We shall presently return to the consideration of the probable value of q .

Besides radiation there is also to be considered the influence of conductivity in causing transfer of heat, and further there are the effects of viscosity. The problems thus suggested have been solved by Stokes and Kirchhoff†. If the law of propagation be

$$u = e^{-m'x} \cos (nt - x/a), \quad (2)$$

then

$$m' = \frac{n^2}{2a^3} \left\{ \frac{4}{3}\mu' + \nu \frac{\gamma - 1}{\gamma} \right\}, \quad (3)$$

in which the frequency of vibration is $n/2\pi$, μ' is the kinematic viscosity, and ν the thermometric conductivity. In C.G.S. measure we may take $\mu' = \cdot 14$, $\nu = \cdot 26$, so that

$$\frac{4}{3}\mu' + \nu \frac{\gamma - 1}{\gamma} = \cdot 25.$$

To take a particular case, let the frequency be 256; then since $a = 33200$, we find for the time of propagation during which the amplitude diminishes in the ratio of $e : 1$,

$$(m'a)^{-1} = 3560 \text{ seconds.}$$

Accordingly it is only very high sounds whose propagation can be appreciably influenced by viscosity and conductivity.

If we combine the effects of radiation with those of viscosity and conduction, we have as the factor of attenuation

$$e^{-(m+m')x},$$

where $m + m' = \cdot 14(q/a) + \cdot 12(n^2/a^3)$ (4)

In actual observations of sound we must expect the intensity to fall off in accordance with the law of inverse squares of distances. A very little experience of moderately distant sounds shows that in fact the intensity is in a high degree uncertain. These discrepancies are attributable to

* Proc. Roy. Inst., April 9, 1879.

† Pogg. Ann. vol. cxxxiv. p. 177, 1868; Theory of Sound, 2nd ed., § 348.

atmospheric refraction and reflexion, and they are sometimes very surprising. But the question remains whether in a uniform condition of the atmosphere the attenuation is sensibly more rapid than can be accounted for by the law of inverse squares. Some interesting experiments towards the elucidation of this matter have been published by Mr. Wilmer Duff *, who compared the distances of audibility of sounds proceeding respectively from two and from eight similar whistles. On an average the eight whistles were audible only about one-fourth further than a pair of whistles ; whereas, if the sphericity of the waves had been the only cause of attenuation, the distances would have been as 2 to 1. Mr. Duff considers that in the circumstances of his experiments there was little opportunity for atmospheric irregularities, and he attributes the greater part of the falling off to radiation. Calculating from (1) he deduces a radiating power such that a mass of air at any given excess of temperature above its surroundings will (if its volume remain constant) fall by radiation to one-half of that excess in about one-twelfth of a second.

In this paper I propose to discuss further the question of the radiating power of air, and I shall contend that on various grounds it is necessary to restrict it to a value hundreds of times smaller than that above mentioned. On this view Mr. Duff's results remain unexplained. For myself I should still be disposed to attribute them to atmospheric refraction. If further experiment should establish a rate of attenuation of the order in question as applicable in uniform air, it will I think be necessary to look for a cause not hitherto taken into account. We might imagine a delay in the equalization of the different sorts of energy in a gas undergoing compression, not wholly insensible in comparison with the time of vibration of the sound. If in the dynamical theory we assimilate the molecules of a gas to hard smooth bodies which are nearly but not absolutely spherical, and trace the effect of a rapid compression, we see that at the first moment the increment of energy is wholly translational and thus produces a maximum effect in opposing the compression. A little later a due proportion of the excess of energy will have passed into rotational forms which do not influence the pressure, and this will accordingly fall off. Any effect of the kind must give rise to dissipation, and the amount of it will increase with the time required for the transformations, *i. e.* in the above mentioned illustration with the degree of approximation to the spherical form. In the case of absolute spheres no transformation of translatory into rotatory energy, or *vice versa*, would

* Phys. Review, vol. vi. p. 129, 1898.

occur in a finite time. There appears to be nothing in the behaviour of gases, as revealed to us by experiment, which forbids the supposition of a delay capable of influencing the propagation of sound.

Returning now to the question of the radiating power of air, we may establish a sort of superior limit by an argument based upon the theory of exchanges, itself firmly established by the researches of B. Stewart. Consider a spherical mass of radius r , slightly and uniformly heated. Whatever may be the radiation proceeding from a unit of surface, it must be less than the radiation from an ideal black surface under the same conditions. Let us, however, suppose that the radiation is the same in both cases and inquire what would then be the rate of cooling. According to Bottomley* the emissivity of a blackened surface moderately heated is $\cdot 0001$. This is the amount of heat reckoned in water-gram-degree units emitted in one second from a square centimetre of surface heated 1°C . If the excess of temperature be θ , the whole emission is

$$\theta \times 4\pi r^2 \times \cdot 0001.$$

On the other hand, the capacity for heat is

$$\frac{4}{3} \pi r^3 \times \cdot 0013 \times \cdot 24,$$

the first factor being the volume, the second the density, and the third the specific heat of air referred as usual to water. Thus for the rate of cooling,

$$\frac{d\theta}{\theta dt} = - \frac{\cdot 0003}{\cdot 0013 \times \cdot 24 \times r} = - \frac{1}{r} \text{ very nearly,}$$

whence $\theta = \theta_0 e^{-t/r}$, (5)

θ_0 being the initial value of θ . The time in seconds of cooling in the ratio of $e : 1$ is thus represented numerically by r expressed in centims.

When r is very great, the suppositions on which (5) is calculated will be approximately correct, and that equation will then represent the actual law of cooling of the sphere of air, supposed to be maintained uniform by mixing if necessary. But ordinary experience, and more especially the observations of Tyndall upon the diathermancy of air, would lead us to suppose that this condition of things would not be approached until r reached 1000 or perhaps 10,000 centims. For values of r comparable with the half wave-length of ordinary sounds, *e.g.* 30 centim., it would seem that the real time of cooling must be a large multiple of that given by (5).

* Everett, C.G.S. Units, 1891, p. 134.

At this rate the time of cooling of a mass of air must exceed, and probably largely exceed, 60 seconds. To suppose that this time is one-twelfth of a second would require a sphere of air 2 millim. in diameter to radiate as much heat as if it were of blackened copper at the same temperature.

Although, if the above argument is correct, there seems little likelihood of the cooling of moderate masses of air being sensibly influenced by radiation, I thought it would be of interest to inquire whether the observed cooling (or heating) in an experiment on the lines of Clement and Desormes could be adequately explained by the conduction of heat from the walls of the vessel in accordance with the known conductivity of air. A nearly spherical vessel of glass of about 35 centim. diameter, well encased, was fitted, air-tight, with two tubes. One of these led to a manometer charged with water or sulphuric acid; the other was provided with a stopcock and connected with an air-pump. In making an experiment the stopcock was closed and a vacuum established in a limited volume upon the further side. A rapid opening and re-closing of the cock allowed a certain quantity of air to escape suddenly, and thus gave rise to a nearly uniform cooling of that remaining behind in the vessel. At the same moment the liquid rose in the manometer, and the observation consisted in noting the times (given by a metronome beating seconds) at which the liquid in its descent passed the divisions of a scale, as the air recovered the temperature of the containing vessel. The first record would usually be at the third or fourth second from the turning of the cock, and the last after perhaps 120 seconds. In this way data are obtained for a plot of the curve of pressure; and the part actually observed has to be supplemented by extrapolation, so as to go back to the zero of time (the moment of turning the tap) and to allow for the drop which might occur subsequent to the last observation. An estimate, which cannot be much in error, is thus obtained of the whole rise in pressure during the recovery of temperature, and for the time, reckoned from the commencement, at which the rise is equal to one-half of the total.

In some of the earlier experiments the whole rise of pressure (fall in the manometer) during the recovery of temperature was about 20 millim. of water, and the time of half recovery was 15 seconds. I was desirous of working with the minimum range, since only in this way could it be hoped to eliminate the effect of gravity, whereby the interior and still cool parts of the included air would be made to fall and so come into closer proximity to the walls, and thus

accelerate the mean cooling. In order to diminish the disturbance due to capillarity, the bore of the manometer-tube, which stood in a large open cistern, was increased to about 18 millim.*, and suitable optical arrangements were introduced to render small movements easily visible. By degrees the range was diminished, with a prolongation of the time of half recovery to 18, 22, 24, and finally to about 26 seconds. The minimum range attained was represented by 3 or 4 millim. of water, and at this stage there did not appear to be much further prolongation of cooling in progress. There seemed to be no appreciable difference whether the air was artificially dried or not, but in no case was the moisture sufficient to develop fog under the very small expansions employed. The result of the experiments may be taken to be that when the influence of gravity was, as far as practicable, eliminated, the time of half recovery of temperature was about 26 seconds.

It may perhaps be well to give an example of an actual experiment. Thus in one trial on Nov. 1, the recorded times of passage across the divisions of the scale were 3, 6, 11, 18, 26, 35, 47, 67, 114 seconds. The divisions themselves were millimetres, but the actual movements of the meniscus were less in the proportion of about $2\frac{1}{2}:1$. A plot of these numbers shows that one division must be added to represent the movement between 0^s and 3^s , and about as much for the movement to be expected between 114^s and ∞ . The whole range is thus 10 divisions (corresponding to 4 millim. at the meniscus), and the mid point occurs at 26^s . On each occasion 3 or 4 sets of readings were taken under given conditions with fairly accordant results.

It now remains to compare with the time of heating derived from theory. The calculation is complicated by the consideration that when during the process any part becomes heated, it expands and compresses all the other parts, thereby developing heat in them. From the investigation which follows †, we see that the time of half recovery t is given by the formula

$$t = \frac{.184\gamma a^2}{\pi^2\nu}, \dots \dots \dots (6)$$

in which a is the radius of the sphere, γ the ratio of specific heats (1.41), and ν is the thermometric conductivity, found by dividing the ordinary or calorimetric conductivity by the

* It must not be forgotten that too large a diameter is objectionable, as leading to an augmentation of volume during an experiment, as the liquid falls.

† See next paper.

thermal capacity of unit volume. This thermal capacity is to be taken with volume constant, and it will be less than the thermal capacity with pressure constant in the ratio of $\gamma : 1$. Accordingly ν/γ in (6) represents the latter thermal capacity, of which the experimental value is $\cdot 00128 \times \cdot 239$, the first factor representing the density of air referred to water. Thus, if we take the calorimetric conductivity at $\cdot 000056$, we have in c.g.s. measure

$$\nu = \cdot 258, \quad \nu/\gamma = \cdot 183 ;$$

and thence

$$t = \cdot 102 a^2.$$

In the present apparatus a , determined by the contents, is 16.4 centim., whence

$$t = 27.4 \text{ seconds.}$$

The agreement of the observed and calculated values is quite as close as could have been expected, and confirms the view that the transfer of heat is due to conduction, and that the part played by radiation is insensible. From a comparison of the experimental and calculated curves, however, it seems probable that the effect of gravity was not wholly eliminated, and that the later stages of the phenomenon, at any rate, may still have been a little influenced by a downward movement of the central parts.

XXV. *On the Conduction of Heat in a Spherical Mass of Air confined by Walls at a Constant Temperature.* By Lord RAYLEIGH, F.R.S.*

IT is proposed to investigate the subsidence to thermal equilibrium of a gas slightly disturbed therefrom and included in a solid vessel whose walls retain a constant temperature. The problem differs from those considered by Fourier in consequence of the mobility of the gas, which may give rise to two kinds of complication. In the first place gravity, taking advantage of the different densities prevailing in various parts, tends to produce circulation. In many cases the subsidence to equilibrium must be greatly modified thereby. But this effect diminishes with the amount of the temperature disturbance, and for infinitesimal disturbances the influence of gravity disappears. On the other hand, the second complication remains, even though we limit ourselves to infinitesimal disturbances. When one part of the gas expands in consequence of reception of heat by

* Communicated by the Author.

radiation or conduction, it compresses the remaining parts, and these in their turn become heated in accordance with the laws of gases. To take account of this effect a special investigation is necessary.

But although the fixity of the boundary does not suffice to prevent local expansions and contractions and consequent motions of the gas, we may nevertheless neglect the inertia of these motions since they are very slow in comparison with the free oscillations of the mass regarded as a resonator. Accordingly the pressure, although variable with time, may be treated as uniform at any one moment throughout the mass.

In the usual notation*, if s be the condensation and θ the excess of temperature, the pressure p is given by

$$p = k\rho(1 + s + \alpha\theta). \quad \dots \dots \dots (1)$$

The effect of a small sudden condensation s is to produce an elevation of temperature, which may be denoted by βs . Let dQ be the quantity of heat entering the element of volume in the time dt , measured by the rise of temperature which it would produce, if there were no "condensation." Then

$$\frac{d\theta}{dt} = \beta \frac{ds}{dt} + \frac{dQ}{dt}; \quad \dots \dots \dots (2)$$

and, if the passage of dQ be the result of radiation and conduction, we have

$$\frac{dQ}{dt} = \nu \nabla^2 \theta - q\theta. \quad \dots \dots \dots (3)$$

In (3) ν represents the "thermometric conductivity" found by dividing the conductivity by the thermal capacity of the gas (per unit volume), at constant volume. Its value for air at 0° and atmospheric pressure may be taken to be $\cdot 26$ cm^2/sec . Also q represents the radiation, supposed to depend only upon the excess of temperature of the gas over that of the enclosure.

If $dQ=0$, $\theta = \beta s$, and in (1)

$$p = k\rho\{1 + (1 + \alpha\beta)s\};$$

so that

$$1 + \alpha\beta = \gamma, \quad \dots \dots \dots (4)$$

where γ is the well-known ratio of specific heats, whose value for air and several other gases is very nearly 1.41.

In general from (2) and (3)

$$\frac{d\theta}{dt} = \beta \frac{ds}{dt} + \nu \nabla^2 \theta - q\theta. \quad \dots \dots \dots (5)$$

* 'Theory of Sound,' § 247.

In order to find the normal modes into which the most general subsidence may be analysed, we are to assume that s and θ are functions of the time solely through the factor e^{-ht} . Since p is uniform, $s + \alpha\theta$ must by (1) be of the form $H e^{-ht}$, where H is some constant; so that if for brevity the factor e^{-ht} be dropped,

$$s + \alpha\theta = H; \dots \dots \dots (6)$$

while from (5)

$$\nu \nabla^2 \theta + (h - q)\theta = h\beta s. \dots \dots \dots (7)$$

Eliminating s between (5) and (7), we get

$$\nabla^2 \theta + m^2(\theta - C) = 0, \dots \dots \dots (8)$$

where

$$m^2 = \frac{h\gamma - q}{\nu}, \quad C = \frac{h\beta H}{h\gamma - q}. \dots \dots \dots (9)$$

These equations are applicable in the general case, but when radiation and conduction are both operative the equation by which m is determined becomes rather complicated. If there be no conduction, $\nu = 0$. The solution is then very simple, and may be worth a moment's attention.

Equations (6) and (7) give

$$\theta = \frac{h\beta H}{h\gamma - q}, \quad s = \frac{(h - q)H}{h\gamma - q}. \dots \dots \dots (10)$$

Now the mean value of s throughout the mass, which does not change with the time, must be zero; so that from (10) we obtain the alternatives

$$(i.) \quad h = q, \quad (ii.) \quad H = 0.$$

Corresponding to (i.) we have with restoration of the time-factor

$$\theta = (H/\alpha)e^{-qt}, \quad s = 0. \dots \dots \dots (11)$$

In this solution the temperature is uniform and the condensation zero throughout the mass. By means of it any initial mean temperature may be provided for, so that in the remaining solutions the mean temperature may be considered to be zero.

In the second alternative $H = 0$, so that $s = -\alpha\theta$. Using this in (7) with ν evanescent, we get

$$(h\gamma - q)\theta = 0. \dots \dots \dots (12)$$

The second solution is accordingly

$$\theta = \phi(x, y, z)e^{-qt/\gamma}, \quad s = -\alpha\phi(x, y, z)e^{-qt/\gamma}, \dots (13)$$

where ϕ denotes a function arbitrary throughout the mass, except for the restriction that its mean value must be zero.

Thus if Θ denote the initial value of θ as a function of x, y, z , and Θ_0 its mean value, the complete solution may be written

$$\left. \begin{aligned} \theta &= \Theta_0 e^{-qt} + (\Theta - \Theta_0) e^{-qt/\gamma} \\ s &= -\alpha(\Theta - \Theta_0) e^{-qt/\gamma} \end{aligned} \right\}, \dots (14)$$

giving

$$s + \alpha\theta = \alpha\Theta_0 e^{-qt}. \dots (15)$$

It is on (15) that the variable part of the pressure depends.

When the conductivity ν is finite, the solutions are less simple and involve the form of the vessel in which the gas is contained. As a first example we may take the case of gas bounded by two parallel planes perpendicular to x , the temperature and condensation being even functions of x measured from the mid-plane. In this case $\nabla^2 = d^2/dx^2$, and we get

$$\theta = C + A \cos mx, \quad -s/\alpha = D + A \cos mx, \dots (16)$$

$$s + \alpha\theta = \alpha C - \alpha D = H. \dots (17)$$

By (9), (17)

$$C = \frac{h\beta H}{h\gamma - q}, \quad D = \frac{(q-h)H}{\alpha(h\gamma - q)}. \dots (18)$$

There remain two conditions to be satisfied. The first is simply that $\theta = 0$ when $x = \pm a$, $2a$ being the distance between the walls. This gives

$$C + A \cos ma = 0. \dots (19)$$

The remaining condition is given by the consideration that the mean value of s , proportional to $\int s dx$, must vanish. Accordingly

$$ma \cdot D + \sin ma \cdot A = 0. \dots (20)$$

From (18), (19), (20) we have as the equation for the admissible values of m ,

$$\frac{\tan ma}{ma} = \frac{\alpha\beta q - \nu m^2}{\alpha\beta(q + \nu m^2)}, \dots (21)$$

reducing for the case of evanescent q to

$$\frac{\tan ma}{ma} = -\frac{1}{\alpha\beta}. \dots (22)$$

The general solution may be expressed in the series

$$\left. \begin{aligned} \theta &= A_1 e^{-h_1 t} \theta_1 + A_2 e^{-h_2 t} \theta_2 + \dots \\ s &= A_1 e^{-h_1 t} s_1 + A_2 e^{-h_2 t} s_2 + \dots \end{aligned} \right\}, \dots (23)$$

where h_1, h_2, \dots are the values of h corresponding according to (9) with the various values of m , and $\theta_1, \theta_2, \dots$ are of the form

$$\left. \begin{aligned} \theta_1 &= \cos m_1 x - \cos m_1 a \\ s_1 &= -\alpha(\cos m_1 x - \sin m_1 a / m_1 a) \end{aligned} \right\} \dots \dots (24)$$

It only remains to determine the arbitrary constants A_1, A_2, \dots to suit prescribed initial conditions. We will limit ourselves to the simpler case of $q=0$, so that the values of m are given by (22). With use of this relation and putting for brevity $a=1$, we find from (24)

$$\int_0^1 \theta_1 \theta_2 dx = \frac{\alpha\beta + 1}{\alpha\beta} \cos m_1 \cos m_2,$$

$$\int_0^1 s_1 s_2 dx = -\frac{\alpha\beta + 1}{\beta^2} \cos m_1 \cos m_2;$$

so that

$$\int_0^1 \theta_1 \theta_2 dx + \beta/\alpha \cdot \int_0^1 s_1 s_2 dx = 0, \dots \dots (25)$$

θ_1, θ_2 being any (different) functions of the form (24). Also

$$\int_0^1 \theta_1^2 dx + \beta/\alpha \cdot \int_0^1 s_1^2 dx = \frac{1 + \alpha\beta}{2} \left\{ 1 + \frac{\cos^2 m_1}{\alpha\beta} \right\} \dots (26)$$

There is now no difficulty in finding A_1, A_2, \dots to suit arbitrary initial values of θ and its associated s , *i. e.* so that

$$\left. \begin{aligned} \Theta &= A_1 \theta_1 + A_2 \theta_2 + \dots \\ S &= A_1 s_1 + A_2 s_2 + \dots \end{aligned} \right\} \dots \dots (27)$$

Thus to determine A_1 ,

$$\int_0^1 (\Theta \theta_1 + \beta/\alpha \cdot S s_1) dx = A_1 \int_0^1 (\theta_1^2 + \beta/\alpha \cdot s_1^2) dx$$

$$+ A_2 \int_0^1 (\theta_1 \theta_2 + \beta/\alpha \cdot s_1 s_2) dx + \dots \dots \dots$$

in which the coefficients of A_2, A_3, \dots vanish by (25); so that by (26)

$$A_1 \left\{ 1 + \frac{\cos^2 m_1}{\alpha\beta} \right\} = \frac{2}{1 + \alpha\beta} \int_0^1 (\Theta \theta_1 + \beta/\alpha \cdot S s_1) dx. \dots (28)$$

An important particular case is that in which Θ is constant, and accordingly $S=0$. Since

$$\int_0^1 \theta_1 dx = \frac{\sin m_1}{m_1} - \cos m_1 = -\frac{1 + \alpha\beta}{\alpha\beta} \cos m_1,$$

we have

$$A_1 = -\frac{2\Theta \cos m_1}{\alpha\beta + \cos^2 m_1} \dots \dots \dots (29)$$

For the pressure we have

$$\begin{aligned} \theta + s/\alpha &= A_1 e^{-h_1 t} \left(-\cos m_1 + \frac{\sin m_1}{m_1} \right) + \dots \\ &= -\frac{\alpha\beta + 1}{\alpha\beta} \cos m_1 \cdot A_1 e^{-h_1 t} + \dots \dots \dots, \end{aligned}$$

or in the particular case of (29),

$$\theta + s/\alpha = 2\Theta \frac{1 + \alpha\beta}{\alpha\beta} \frac{\cos^2 m_1 e^{-h_1 t}}{\alpha\beta + \cos^2 m_1} + \dots \dots \dots (30)$$

If $\beta=0$, we fall back upon a problem of the Fourier type. By (22) in that case

$$ma = \frac{1}{2}\pi(1, 3, 5, \dots)$$

and

$$\cos^2 ma = \alpha^2 \beta^2 / m^2 a^2,$$

so that (30) becomes

$$2\Theta \left(\frac{e^{-h_1 t}}{m_1^2 a^2} + \frac{e^{-h_2 t}}{m_2^2 a^2} + \dots \right), \dots \dots (31)$$

or initially

$$\frac{8\Theta}{\pi^2} \left(\frac{1}{1^2} + \frac{1}{3^2} + \frac{1}{5^2} + \dots \right), \text{ i. e. } \Theta.$$

The values of h are given by

$$h = \frac{\nu\pi^2}{4\gamma a^2} (1^2, 3^2, 5^2, \dots). \dots \dots (32)$$

We will now pass on to the more important practical case of a spherical envelope of radius a . The equation (8) for $(\theta - C)$ is identical with that which determines the vibrations of air * in a spherical case, and the solution may be expanded in Laplace's series. The typical term is

$$\theta - C = (mr)^{-\frac{1}{2}} J_{n+\frac{1}{2}}(mr) \cdot Y_n, \dots \dots (33)$$

Y_n being the surface spherical harmonic of order n where $n=0, 1, 2, 3, \dots$, and J the symbol of Bessel's functions. In virtue of (6) we may as before equate $-s/\alpha - D$, where D is another constant, to the right-hand member of (33). The two conditions yet to be satisfied are that $\theta=0$ when $r=a$, and that the mean value of s throughout the sphere shall vanish.

* 'Theory of Sound,' vol. II. ch. xvii.

When the value of n is greater than zero, the first of these conditions gives $C=0$ and the second $D=0$; so that

$$\theta = -s/\alpha = (mr)^{-\frac{1}{2}} J_{n+\frac{1}{2}}(mr) \cdot Y_n, \dots (34)$$

and $s + \alpha\theta = 0$. Accordingly these terms contribute nothing to the pressure. It is further required that

$$J_{n+\frac{1}{2}}(ma) = 0, \dots (35)$$

by which the admissible values of m are determined. The roots of (35) are discussed in 'Theory of Sound,' § 206 . . . ; but it is not necessary to go further into the matter here, as interest centres rather upon the case $n=0$.

If we assume symmetry with respect to the centre of the sphere, we may replace ∇^2 in (8) by $\frac{1}{r} \frac{d^2}{dr^2} r$, thus obtaining

$$\frac{d^2 r(\theta - C)}{dr^2} + m^2 r(\theta - C) = 0, \dots (36)$$

of which the general solution is

$$\theta = C + A \frac{\cos mr}{mr} + B \frac{\sin mr}{mr}.$$

But for the present purpose the term $r^{-1} \cos mr$ is excluded, so that we may write

$$\theta = C + B \frac{\sin mr}{mr}, \quad -s/\alpha = D + B \frac{\sin mr}{mr}, \dots (37)$$

giving

$$s + \alpha\theta = \alpha(C - D) = H. \dots (37 \text{ bis})$$

The first special condition gives

$$maC + B \sin ma = 0. \dots (38)$$

The second, that the mean value of s shall vanish, gives on integration

$$\frac{3}{8} m^3 a^3 D + B(\sin ma - ma \cos ma) = 0. \dots (39)$$

Equations (18), derived from (9) and (37 bis), giving C and D in terms of H , hold good as before. Thus

$$\frac{D}{C} = \frac{q-h}{h\alpha\beta} = \frac{\alpha\beta q - vm^2}{\alpha\beta(q + vm^2)}. \dots (40)$$

Equating this ratio to that derived from (38), (39), we find

$$\frac{3}{m^2 a^2} \frac{ma \cos ma - \sin ma}{\sin ma} = \frac{vm^2 - \alpha\beta q}{\alpha\beta(vm^2 + q)}. \dots (41)$$

This is the equation from which m is to be found, after which h is given by (9).

In the further discussion we will limit ourselves to the case of $q=0$, when (41) reduces to

$$m^2 = 3\alpha\beta(m \cot m - 1), \quad \dots \quad (42)$$

in which a has been put equal to unity. Here by (40)

$$D = -C/\alpha\beta.$$

Thus we may set as in (23),

$$\left. \begin{aligned} \theta &= B_1 e^{-h_1 t} \theta_1 + B_2 e^{-h_2 t} \theta_2 + \dots \dots \dots \\ s &= B_1 e^{-h_1 t} s_1 + B_2 e^{-h_2 t} s_2 + \dots \dots \dots \end{aligned} \right\}, \quad \dots \quad (43)$$

in which

$$\theta_1 = \frac{\sin m_1 r}{m_1 r} - \frac{\sin m_1 a}{m_1 a}, \quad s_1 = -\alpha \frac{\sin m_1 r}{m_1 r} - \frac{1}{\beta} \frac{\sin m_1 a}{m_1 a}, \quad (44)$$

and by (9) $h_1 = \nu m_1^2 / \gamma$. Also

$$s_1 / \alpha + \theta_1 = -\frac{1 + \alpha\beta}{\alpha\beta} \frac{\sin m_1 a}{m_1 a} \dots \dots \dots (45)$$

The process for determining B_1, B_2, \dots follows the same lines as before. By direct integration from (44) we find

$$\begin{aligned} &\frac{2m_1 m_2}{1 + \alpha\beta} \int_0^1 (\theta_1 \theta_2 + \beta/\alpha \cdot s_1 s_2) r^2 dr \\ &= \frac{\sin(m_1 - m_2)}{m_1 - m_2} - \frac{\sin(m_1 + m_2)}{m_1 + m_2} + \frac{2 \sin m_1 \sin m_2}{3\alpha\beta}, \end{aligned}$$

a being put equal to unity. By means of equation (42) satisfied by m_1 and m_2 we may show that the quantity on the right in the above equation vanishes. For the sum of the first two fractions is

$$\frac{2m_2 \sin m_1 \cos m_2 - 2m_1 \sin m_2 \cos m_1}{m_1^2 - m_2^2},$$

of which the denominator by (42) is equal to

$$3\alpha\beta(m_1 \cot m_1 - m_2 \cot m_2).$$

Accordingly $\int_0^1 (\theta_1 \theta_2 + \beta/\alpha \cdot s_1 s_2) r^2 dr = 0. \dots \dots (46)$

Also

$$\frac{2m_1^2}{1+\alpha\beta} \int_0^1 (\theta_1^2 + \beta/\alpha \cdot s_1^2) r^2 dr = 1 - \frac{\sin 2m_1}{2m_1} + \frac{2 \sin^2 m_1}{3\alpha\beta} \quad (47)$$

To determine the arbitrary constants $B_1 \dots$ from the given initial values of θ and s , say Θ and S , we proceed as usual. We limit ourselves to the term of zero order in spherical harmonics, *i. e.* to the supposition that θ, s are functions of r only. The terms of higher order in spherical harmonics, if present, are treated more easily, exactly as in the ordinary theory of the conduction of heat. By (43)

$$\left. \begin{aligned} \Theta &= B_1\theta_1 + B_2\theta_2 + \dots \\ S &= B_1s_1 + B_2s_2 + \dots \end{aligned} \right\}; \quad \dots \quad (48)$$

and thus

$$\begin{aligned} \int_0^1 (\Theta\theta_1 + \beta/\alpha \cdot Ss_1) r^2 dr &= B_1 \int_0^1 (\theta_1^2 + \beta/\alpha \cdot s_1^2) r^2 dr \\ &+ B_2 \int_0^1 (\theta_1\theta_2 + \beta/\alpha \cdot s_1s_2) r^2 dr + \dots, \end{aligned}$$

in which the coefficients of B_2, B_3, \dots vanish by (46). The coefficient of B_1 is given by (47). Thus

$$B_1 \left\{ 1 - \frac{\sin 2m_1}{2m_1} + \frac{2 \sin^2 m_1}{3\alpha\beta} \right\} = \frac{2m_1^2}{1+\alpha\beta} \int_0^1 (\Theta\theta_1 + \beta/\alpha \cdot Ss_1) r^2 dr, \quad \dots \quad (49)$$

by which B_1 is determined.

An important particular case is that where Θ is constant and accordingly S vanishes. Now with use of (42)

$$\int_0^1 \theta_1 r^2 dr = \frac{\sin m_1 - m_1 \cos m_1}{m_1^3} - \frac{\sin m_1}{3m_1} = - \frac{(1+\alpha\beta) \sin m_1}{3\alpha\beta m_1};$$

so that

$$B_1 \left\{ 1 - \frac{\sin 2m_1}{2m_1} + \frac{2 \sin^2 m_1}{3\alpha\beta} \right\} = - \frac{2m_1 \sin m_1 \cdot \Theta}{3\alpha\beta} \quad (50)$$

B_1, B_2, \dots being thus known, θ and s are given as functions of the time and of the space coordinates by (43), (44).

To determine the pressure in this case we have from (45)

$$\frac{\theta + s/\alpha}{\Theta} = \frac{1+\alpha\beta}{\alpha\beta} \sum \frac{\sin^2 m \cdot e^{-ht}}{\sin^2 m + \frac{3\alpha\beta}{2} \left(1 - \frac{\sin 2m}{2m} \right)}, \quad \dots \quad (51)$$

the summation extending to all the values of m in (42). Since (for each term) the mean value of s is zero, the right-hand member of (51) represents also $\bar{\theta}/\Theta$, where $\bar{\theta}$ is the mean value of θ .

If in (51) we suppose $\beta=0$, we fall back upon a known Fourier solution, relative to the mean temperature of a spherical solid which having been initially at uniform temperature Θ throughout is afterwards maintained at zero all over the surface. From (42) we see that in this case $\sin m$ is small and of order β . Approximately

$$\sin m = 3\alpha\beta/m;$$

and (51) reduces to

$$\frac{\bar{\theta}}{\Theta} = \frac{6}{\pi^2} \left(\frac{e^{-h_1 t}}{1^2} + \frac{e^{-h_2 t}}{2^2} + \frac{e^{-h_3 t}}{3^2} + \dots \right), \quad \dots \quad (52)$$

of which by a known formula the right-hand member identifies itself with unity when $t=0$. By (9) with restoration of a ,

$$h = (1^2, 3^2, 5^2, \dots) \nu \pi^2 / a^2. \quad \dots \quad (53)$$

In the general case we may obtain from (42) an approximate value applicable when m is moderately large. The first approximation is $m=i\pi$, i denoting an integer. Successive operations give

$$m = i\pi + \frac{3\alpha\beta}{i\pi} - \frac{18\alpha^2\beta^2 + 9\alpha^3\beta^3}{i^3\pi^3} \dots \quad (54)$$

In like manner we find approximately in (51)

$$\frac{\sin^2 m (1 + \alpha\beta) / \alpha\beta}{\sin^2 m + \frac{3\alpha\beta}{2} \left(1 - \frac{\sin 2m}{2m} \right)} = \frac{6(1 + \alpha\beta)}{i^2\pi^2} \left\{ 1 - \frac{15\alpha\beta + 9\alpha^2\beta^2}{i^2\pi^2} \right\}, \quad \dots \quad (55)$$

showing that the coefficients of the terms of *high order* in (51) differ from the corresponding terms in (52) only by the factor $(1 + \alpha\beta)$ or γ .

In the numerical computation we take $\gamma=1.41$, $\alpha\beta=.41$. The series (54) suffices for finding m when i is greater than 2. The first two terms are found by trial and error with trigonometrical tables from (42). In like manner the approximate value of the left-hand member of (51) therein given suffices when i is greater than 3. The results as far as $i=12$ are recorded in the annexed table.

<i>i.</i>	$m/\pi.$	Left-hand member of (55).	<i>i.</i>	$m/\pi.$	Left-hand member of (55).
1.....	1.0994	.4942	7	7.0177	.0175
2.....	2.0581	.1799	8	8.0156	.0134
3.....	3.0401	.0871	9	9.0138	.0106
4.....	4.0305	.0510	10	10.0125	.0086
5.....	5.0246	.0232	11	11.0113	.0071
6.....	6.0206	.0233	12	12.0104	.0060

Thus the solution (51) of our problem is represented by

$$\bar{\theta}/\Theta = .4942 e^{-(1.0994)^2 t'} + .1799 e^{-(2.0581)^2 t'} + \dots \quad (56)$$

where by (9), with omission of q and restoration of a ,

$$t'/t = \pi^2 \nu / \gamma a^2. \quad (57)$$

The numbers entered in the third column of the above table would add up to unity if continued far enough. The verification is best made by a comparison with the simpler series (52). If with t zero we call this series Σ' and the present series Σ , both Σ and Σ' have unity for their sum, and accordingly $\gamma \Sigma' - \Sigma = \gamma - 1$, or

$$\frac{6\gamma}{\pi^2} \left(\frac{1}{1^2} + \frac{1}{2^2} + \frac{1}{3^2} + \dots \right) - \Sigma = \gamma - 1 = .41.$$

Here $6\gamma/\pi^2 = .8573$, and the difference between this and the first term of Σ , *i. e.* .4942, is .3631. The differences of the second, third, &c. terms are .0344, .0082, .0026, .0011, .0005, .0000, &c., making a total of .4099.

$t'.$	(56).	$t'.$	(56).
.00	1.0000	.602538
.057037	.702215
.106037	.801940
.204811	.901705
.304002	1.001502
.403401	1.500809
.502926	2.000441

We are now in a position to compute the right-hand

member of (56) as a function of t' . The annexed table contains sufficient to give an idea of the course of the function. It is plotted in the figure. The second entry ($t' = \cdot 05$) requires

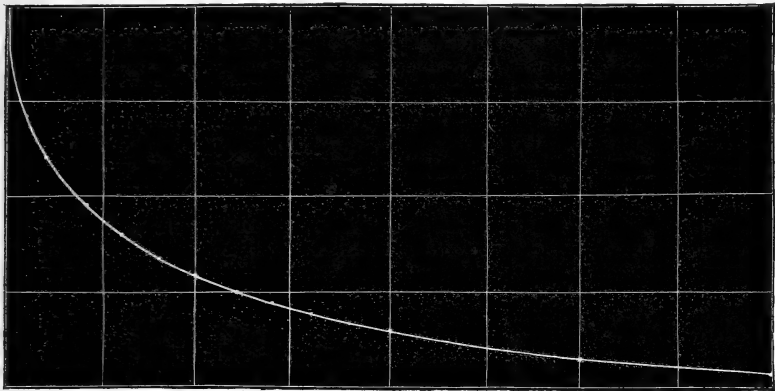

the inclusion of 9 terms of the series. After $t' = \cdot 7$ two terms suffice; and after $t' = 2\cdot 0$ the first term represents the series to four places of decimals.

By interpolation we find that the series attains the value $\cdot 5$ when

$$t' = \cdot 184. \quad (58)$$

XXVI. *Notices respecting New Books.*

An Elementary Course in the Integral Calculus. By Dr. D. A. MURRAY, Cornell University. Longmans, 1898. Pp. x + 288.

DR. MURRAY states his object to be to present "the subject-matter, which is of an elementary character, in a simple manner." This he has succeeded in doing, and the work is well-arranged and the explanations given are exceedingly clear. In Chapter I. he treats Integration as a process of summation, and in Chapter II. as the inverse of differentiation. The author's object herein is to give the student a clear idea of what the Integral Calculus is, and of the uses to which it may be applied. The first ten chapters are devoted to a treatment of the matters handled in such works as Williamson's, Edwards's, and other well-known treatises. Chapter XI. treats of approximate integration, and the application of the Calculus to the measurement of areas. Here we have clear statements and proofs of the trapezoidal rule, Simpson's one-third rule, and Durand's rule. To this latter gentleman the author is indebted for valuable suggestions of use to engineering students. Prof. Durand has also put at Dr. Murray's disposal his article on "Integral Curves" (in the 'Sibley Journal of

Engineering,' vol. xi. no. 4*), and his account of the 'Fundamental Theory of the Planimeter'†. Chapter XIII. is devoted to ordinary differential equations. The Appendix (some 50 pages) discusses some of the matters in the text at greater length than is required by the elementary student, and also contains a large collection of the figures of the curves which are referred to in the exercises. Answers are given to these exercises, and further there is a full Index, and numerous brief historical notes which add to the utility of an excellent text-book. Dr. Murray suitably acknowledges his great indebtedness to his predecessors in the same field. The book is very neatly and correctly printed, and is of handy size.

XXVII. *Proceedings of Learned Societies.*

GEOLOGICAL SOCIETY.

[Continued from vol. xlvi. p. 508.]

November 9th, 1898.—W. Whitaker, B.A., F.R.S., President,
in the Chair.

THE following communications were read:—

1. "On the Palæozoic Radiolarian Rocks of New South Wales." By Prof. T. W. Edgeworth David, B.A., F.G.S., and E. F. Pittman, Esq., Assoc. R.S.M., Government Geologist, New South Wales.

2. 'On the Radiolaria in the Devonian Rocks of New South Wales.' By G. J. Hinde, Ph.D., F.R.S., F.G.S.

November 23rd.—W. Whitaker, B.A., F.R.S., President,
in the Chair.

The following communications were read:—

1. 'Note on a Conglomerate near Melmerby (Cumberland).' By J. E. Marr, Esq., M.A., F.R.S., F.G.S.

In this paper the author describes the occurrence of a conglomeratic deposit which shows indubitable effects of earth-movement, not only on the included pebbles, but also on the surface of one of the deposits. The rocks are coloured as basement Carboniferous rocks on the Geological Survey map. The Skiddaw Slates are succeeded by about 30 feet of a roughly stratified conglomerate, followed by 20 to 30 feet of rock with small pebbles, and that by a second coarse conglomerate. The pebbles possess the outward form of glacial boulders, but many of them are slickensided, fractured, faulted, and indented. The striæ are often curved, parallel, and covered by mineral deposit; the grains of the matrix are embedded in the grooves, while slickensiding often occurs beneath the surface of the pebbles and the striæ are seen to begin or end at a fault-plane. The surface of rock beneath

* Chapter XII. of the work before us is almost a reproduction of this article, as is also Appendix G which supplements the account in the text.

† Here suitable reference is made to Prof. Henrici's Report (British Association, 1894) and to Prof. Hele Shaw's paper on 'Mechanical Integrators' ('Proceedings of Institution of Civil Engineers,' vol. lxxxii. 1885).

the upper conglomerate was found to be slickensided. The way in which the surfaces of some of the pebbles have been squeezed-off suggests the possibility that their angular shape may be partially or wholly due to earth-movement.

2. 'Geology of the Great Central Railway (New Extension to London of the Manchester, Sheffield & Lincolnshire Railway): Rugby to Catesby.' By Beeby Thompson, Esq., F.G.S., F.C.S.

In this paper the portion of the line, 10 miles in length, from Catesby to Rugby is described; as the ground falls while the strata rise in this direction, quite low beds in the Lower Lias are met with near Rugby. The lowest zone exposed is that of *Ammonites semicostatus*, in the lower part of which, and in Boulder Clay derived from it, *A. Turneri* has been found. The next succeeding zone, that of *A. obtusus*, although for the most part barren, yielded the characteristic fossils at its base. The *oxynotus*-zone is well developed and well displayed, besides being richly fossiliferous. The zone of *A. varicosatus* merges into that of *A. oxynotus* below and that of *A. armatus* above, and is not more than 3 or 4 feet thick. The *armatus*-zone, beds between that and the *Jamesoni*-zone, and the *Jamesoni*-zone itself follow; the middle beds of the latter being rich in *Rhynchonella* and *A. pettus*, the name of this ammonite is attached to the zone bearing them. The *Ibex*-zone occurs east of Flecknoe, covered by rocks yielding *A. Henleyi*; and the highest beds of this cutting appear to belong to the *capricornus*-zone. Lists of the characteristic fossils of each zone are given, followed by a complete list of all those found in the Lower and Middle Lias of the cuttings, with a statement of their distribution.

The Glacial deposits are described under the following headings:—Blue or local Boulder Clay, brown and grey contorted Boulder Clay, Chalky Lower Boulder Clay, (Mid-Glacial) sands and gravels, and red Upper Boulder Clay.

The paper is accompanied by a measured section along the railway.

3. 'On the Remains of *Amia* from Oligocene Strata in the Isle of Wight.' By E. T. Newton, Esq., F.R.S., F.G.S.

December 7th.—W. Whitaker, B.A., F.R.S., President,
in the Chair.

The following communication was read:—

1. 'The Geological Structure of the Southern Malverns and of the adjacent District to the West.' By Prof. T. T. Groom, M.A., D.Sc., F.G.S.

The Raggedstone and Midsummer Hills, consisting essentially of massive gneissic and schistose rocks, are traversed by a curved depression which marks a line of profound dislocation, probably of the nature of a thrust-plane. This appears to dip towards the east, though with a relatively small hade. Along this depression occur strips of Cambrian and Silurian strata embedded in the Archæan massif, and indicating the presence of a deep and narrow dislocated synclinal fold. In places, the foliation of the schists

shows a marked relation to the direction of this line, indicating in all probability a production of schists from the old material in post-Lower Palæozoic times.

The western boundary of the Archæan massif is everywhere a fault, apparently a thrust-plane, but with a small hade. The direction of this plane is in close relation with the axis of the overfold into which the Cambrian rocks are thrown to the west of these hills.

The western boundary of Chase End Hill is likewise a fault, which is probably a thrust-plane with a tolerably low dip towards the eastern side. The thrust here also appears to have been accompanied by a secondary production of schists from the old gneissic series; and the Cambrian strata are overthrown in the vicinity of the fault.

There is no evidence for the overlap of the Cambrian Series supposed by Holl, the circumstance that the various zones of the Cambrian Series strike up against the Archæan axis being due to faulting.

The Cambrian is represented by the following series:—

- | | | |
|--|---|--|
| 4. GREY SHALES. | { | Upper Grey Shales.
Coal Hill Igneous Band.
Lower Grey Shales.
Middle Igneous Band. |
| 3. BLACK SHALES. | { | Upper Black Shales.
Upper White-leaved-Oak Igneous Band.
Lower Black Shales.
Lower White-leaved-Oak Igneous Band. |
| 2. HOLLYBUSH SANDSTONE. | | |
| 1. HOLLYBUSH QUARTZITE AND CONGLOMERATE. | | |

Fossils are abundant in certain zones of each of the four subdivisions of the series.

The Grey Shales rest conformably on the Black Shales, but the mutual relations of the remaining subdivisions can be decided only by inference, the junctions being apparently everywhere faults. The junction between the Cambrian and Archæan is likewise a fault.

All four divisions of the Cambrian Series are invaded by small igneous bosses, laccolites, and intercalated sheets of diabase and andesitic basalt. These igneous rocks do not penetrate the May Hill Series.

The May Hill Beds seem to rest with apparent conformity upon the Grey Shales, and do not transgress across the various Cambrian zones on to the Archæan in the manner hitherto supposed, the presumed outliers being small patches faulted into the Cambrian.

The structure of the district is to be explained on the supposition that we are dealing with the western margin of an old mountain-chain overfolded towards the west; the eastern portion of this range lies faulted down and buried beneath the Permian and Mesozoic of the Vale of Gloucester. All the characteristics of a folded chain are present, namely, the profound folds, overfolds, thrust-planes, and transverse faults; and a typical *Austönungszone* is seen to the west.

XXVIII. *Intelligence and Miscellaneous Articles.*

ON THE HEAT PRODUCED BY MOISTENING PULVERIZED BODIES.

NEW THERMOMETRICAL AND CALORIMETRICAL RESEARCHES.

BY TITO MARTINI*.

IN my second paper presented, last April, at the R. Istituto Veneto, I dealt with the calorific phenomena observed in moistening pulverized bodies. The method of experiments has already been described †; that is to say, of an arrangement whereby the liquid ascended to the powder, thoroughly dried, placed in a glass tube separated from it by a piece of light linen cloth. In this second series of experiments some modifications were introduced in order to keep the powder as dry as possible till the beginning of the experiment. The thermometer-bulb was placed in contact with the upper stratum of powder, it having been noticed that the increase of temperature was more marked from layer to layer.

In the following tables are indicated some of the principal results obtained with pure charcoal and pure silica (SiO₂).

Pure Charcoal (gr. 25).

Name of the Liquid.	Temp. of the Air.	Temp. of the Liquid.	Temp. of the Charcoal.	Max. Temp.	Increase of Temp.	Liquid absorbed in cm. ³
Distilled water	9	8.25	9.20	34.30	25.10	35 cm. ³
Absolute alcohol	19.16	19.10	19.29	45.05	25.76	30
Sulphuric ether	10.71	11.10	10.89	29.48	18.59	28
Acetic ether	19.30	19.42	19.60	44.60	25.00	32
Benzene	20.10	20.15	20.30	33.60	13.30	34
Bisulphide of carbon.	7.10	6.12	7.20	28.90	21.70	29

Pure Silica (gr. 25).

Name of the Liquid.	Temp. of the Air.	Temp. of the Liquid.	Temp. of the Silica.	Max. Temp.	Increase of the Temp.	Liquid absorbed.
Distilled water	19.00	18.96	19.30	41.90	22.60	37 cm. ³
Absolute alcohol	19.27	18.87	19.60	45.75	26.15	36
Sulphuric ether.....	14.65	14.60	14.69	46.21	31.52	35
Acetic ether	20.19	20.25	20.70	50.80	30.55	7
Benzene	19.50	19.49	19.60	31.70	12.10	40
Bisulphide of carbon...	18.84	18.95	19.32	31.05	11.73	38

I made also many experiments in order to determine the number of calories produced by moistening powder. I adopted a special

* "Intorno ad calore che si sviluppa nel bagnare le polveri. Nuove ricerche termometriche e calorimetriche." *Atti del R. Istituto Veneto*, t. 9, serie vii. p. 927.

† *Atti del R. Istituto Veneto*, t. 8, serie vii. p. 502; *Phil. Mag.* vol. xliv., August 1897.

calorimeter made of thin sheet brass, consisting of two cylindrical tubes, one within the other, having a common axis. The base of the internal tube was perforated to allow the escape of air, when pouring the liquid upon the powder with which the tube was filled. A flannel disk placed at the base prevented the escape of the powder.

The powder was thoroughly dried before being poured into the internal tube, which was closed at the top with an indiarubber stopper, and suspended by three silk threads, within a vessel containing chloride of calcium. The external tube contained distilled water into which was immersed a delicate thermometer.

Calories developed by Charcoal moistened with Distilled Water.

Weight of the Charcoal.	Volume of the Water.	Calories-gr.	Calories by 1 gr. of powder.
44 gr.	60 cm. ³	629·00	14·29
40	53	569·80	14·25
40	58	573·30	14·33
35	51	514·30	14·69
30	43	440·30	14·67

Calories developed by Silica moistened with Distilled Water.

Weight of the Silica.	Volume of the Water.	Calories-gr. developed.	Calories by 1 gr. of powder.
50 gr.	72 cm. ³	677·10	13·54
50	70	684·50	13·69
45	63	603·10	13·40
40	60	558·70	13·97
40	62	558·70	13·97
40	66	555·00	13·87
35	53	477·30	13·64

Meissner, in his experiments*, did not use a fixed weight of water; at one time he would use a quantity of water equal in weight to the powder, at another time a quantity double, and at times much less. In my own case, however, I always used that quantity of liquid which I found would be absorbed, by capillarity, by a quantity of charcoal or silica equal to that contained in the calorimeter. Had I poured on the powder a smaller amount of water, parts would have remained unmoistened; a larger quantity would have absorbed a part of the heat generated.

The foregoing results may be of interest, not only to physicists in general, but to students of geothermic phenomena. In fact, the reader will find in my original pamphlet an account of certain experiments in which silica, moistened with a proportionate quantity of water, rose from an initial temperature of 19° to that of 70°.

Venice, June 1898.

* "Ueber die beim Benetzen pulverförmiger Körper auftretende Wärme tönung." Wiedemann's *Annalen*, xix. (1886).

COMBINATION OF AN EXPERIMENT OF AMPÈRE WITH AN
EXPERIMENT OF FARADAY. BY J. J. TAUDIN CHABOT.

It was shown by Ampère * how a magnet can be made to rotate about its axis under the influence of a steady current, and Faraday † showed how the rotation of a magnet about its axis can give rise to a steady current ‡.

By combining these two experiments we obtain a case of induction by steady currents: a steady primary current in the

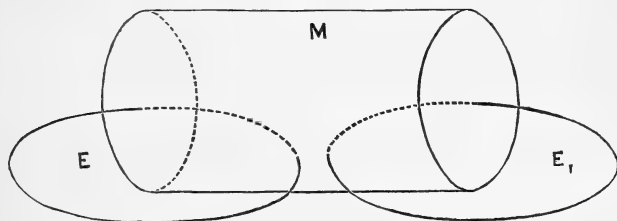

circuit E or E_1 gives rise to a steady secondary current in the circuit E_1 or E , a rotating magnet M forming the connecting link.

In order to show the effect, a brake is applied to the magnet M , a battery is inserted into the circuit E or E_1 and a galvanometer into the other circuit E_1 or E . On closing the circuit we observe that the suspended system of the galvanometer remains at zero; but, on removing the brake from the magnet, this begins to rotate and the galvanometer shows a deflection which increases continuously until the magnet turns quite freely. A brake is desirable which admits of a graduated application.

It appears to me that this experiment is worthy of notice in consideration of its illustrative character §.

Degerloch (Württemberg),
December 12th, 1898.

EXPERIMENTS WITH THE BRUSH DISCHARGE.

To the Editors of the *Philosophical Magazine*.

GENTLEMEN,

I have read with considerable interest the paper by Dr. Cook on the "Brush Discharge" in the January number of your Magazine. May I be allowed to call attention to some experiments made by Lord Blythswood about two years ago, which are of a very

* *Recueil d'Observations*, p. 177 (1821). Lettre à M. van Beck.

† 'Experimental Researches,' series ii., §§ 217-230 (1832); see also series xxviii. (1851).

‡ This phenomenon is generally known by the name of "unipolar" induction; "autopolar" induction (induction autopolaire, Gleichpolinduction), it seems to me, would be better; and therefore I propose this term. Then, in contradistinction, "heteropolar" induction (induction hétéropolaire, Wechseipolinduction) can be used for signifying induction by both the poles alternately (dynamo &c.).

§ See *Phil. Mag.* vol. xlv. p. 428 (Oct. 1898), and p. 571 (Dec. 1898).

similar character. In this case, however, it was the negative glow which was the source of radiation. The machine used was of the Wimshurst type, having 160 3-ft. plates each carrying 16 sectors.

The experiments were made to determine the effect of the rays from the negative glow on a photographic plate.

Small metallic objects were "radiographed," being placed in front of, but not touching, a sensitized plate. The whole was then enclosed in a zinc box (with a small hole cut in the side facing the source of radiation), which was carefully earthed in order to prevent any charge on the metallic object affecting the plate. A piece of 1 mil. aluminium-foil was then placed between the source of radiation and the plate, thus completing the metallic sheath. The arrangement is shown below.

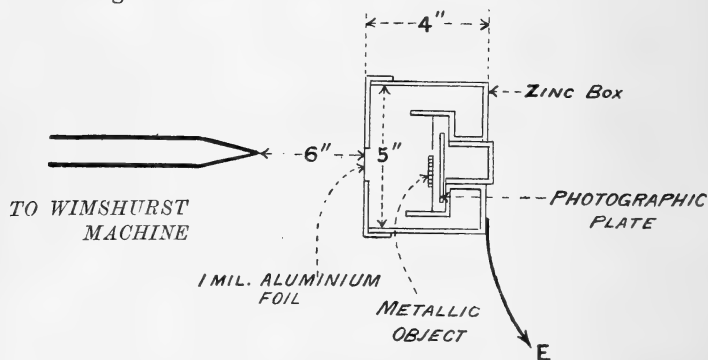

When these precautions were not observed, brush discharges took place from the points of the metallic object (generally a small wheel) which strongly affected the plate.

Distinct shadows of the small wheel were obtained after 5 minutes' exposure in a darkened room. It was at first thought that these photographs were produced by rays similar to the *x*-rays, which had traversed the aluminium-foil; but it appeared afterwards that the whole effect was apparently due to minute holes in the aluminium-foil, since, when the apparatus was wrapped in black velvet, no effects were produced on the plate. That such effects were obtained, however, seems to show that the negative glow possesses strong actinic power, as shown so conclusively by Dr. Cook.

A possible explanation of the diminished effect observed by Dr. Cook on an Electroscope placed at a distance from a point at which a Brush discharge is taking place, when an induction-coil was used in place of the Wimshurst machine, seems to be that the electrification produced would depend on the R.M.S. potential-difference rather than on the maximum value, as indicated by the spark-length. Similarly for the mechanical force produced by the wind from the points.

Yours very truly,
E. W. MARCHANT.

Blythswood Laboratory,
Renfrew, N.B.
Jan. 30, 1899.

THE
LONDON, EDINBURGH, AND DUBLIN
PHILOSOPHICAL MAGAZINE
AND
JOURNAL OF SCIENCE.

[FIFTH SERIES.]

APRIL 1899.

XXIX. *Longitudinal Vibrations in Solid and Hollow Cylinders.* By C. CHREE, Sc.D., LL.D., F.R.S.*

Preliminary.

§ 1. THE frequency $k/2\pi$ of longitudinal vibrations in the ideal isotropic bar of infinitely small cross section has long been known to be given by

$$k = p \sqrt{E/\rho}, \dots \dots \dots (1)$$

where ρ is the density, E Young's modulus; p is given by

$$p = i\pi/l \text{ when the ends are both free or both fixed,}$$

$$p = (2i + 1)\pi/(2l) \text{ when one end is free, the other fixed,}$$

l being the length of the rod and i a positive integer.

For the fundamental or lowest note $i = 1$.

For a circular bar whose radius a , though small compared to l , is not wholly negligible, the closer approximation

$$k = p(E/\rho)^{\frac{1}{2}} \{1 - \frac{1}{4}p^2\eta^2 a^2\}, \dots \dots \dots (2)$$

where η is Poisson's ratio, was obtained independently by Prof. Pochhammer † and Lord Rayleigh‡ fully 20 years ago.

§ 2. The subject has been treated by myself in three papers in the 'Quarterly Journal of ... Mathematics' (A) (p. 287, 1886), (B) (p. 317, 1889), (C) (p. 340, 1890).

In (A) I arrived at (2) describing it (*l. c.* p. 296) as

* Communicated by the Physical Society: read December 9, 1898.

† *Crelle*, vol. lxxxì. (1876).

‡ 'Theory of Sound,' vol. i. art. 157.

“obtained as a second approximation by Lord Rayleigh.” I further said, “We do not think, however, that his proof affords any means of judging of the degree of accuracy of the result, as it is founded on a more or less probable hypothesis and does not profess to be rigid.” I subsequently learned that Lord Rayleigh did not admit any want of rigidity in his proof, and it appears without modification in the second edition of his *Treatise on ‘Sound.’* I much regret having to differ from so eminent an authority, but I have not altered my original opinion.

In (B) I reached the more general result

$$k = p(E/\rho)^{\frac{1}{2}}(1 - \frac{1}{2}p^2\eta^2\kappa^2), \dots \dots \dots (3)$$

where κ is the radius of gyration of the cross section of the rod about its axis. This was established by a strict elastic solid method for an elliptic section, and in a somewhat less rigid way for a rectangular section. (A) and (B) were confined, like the investigations of Lord Rayleigh and Professor Pochhammer, to isotropic materials.

In (C) I considered the more general case of an *æolotropic* bar whose long axis was an axis of material symmetry, and found by strict elastic solid methods that (2) still held for a circular section, if E denoted Young’s modulus for stress along the length of the bar, and η Poisson’s ratio for the consequent perpendicular contractions. Further, applying Lord Rayleigh’s method, modified in a way I deem necessary, I obtained (3) for any form of cross section.

§ 3. Since the publication of (1) Mr. Love has discussed the subject in vol. ii. of his *‘Treatise on Elasticity.’* On his p. 119* he refers to (2) as “first given by Prof. Pochhammer... and afterwards apparently independently by Mr. Chree.” Again, in the new edition of his *‘Sound’* Lord Rayleigh, after deducing (2), says “A more complete solution... has been given by Pochhammer... A similar investigation has also been published by Chree.”

In view of these remarks, I take this opportunity of stating explicitly :—

1. That Pochhammer’s work was wholly unknown to me until the appearance of Love’s *‘Elasticity.’*

2. That my method of solution in (A) is essentially different from Pochhammer’s, while the methods in (B) and (C) are absolutely different from his. The method of (A) agrees with Pochhammer’s in employing the equations of elasticity in cylindrical coordinates. After obtaining, however,—as is

* The preface, p. 13, describes the result as “obtained independently” by me.

customary in most elastic problems—the differential equation for the dilatation, Pochhammer obtains a differential equation for the quantity

$$\frac{1}{2} \left(\frac{du}{dz} - \frac{dw}{dr} \right),$$

u and w being the displacements parallel to the radius r and the axis z , and uses this quantity as a stepping-stone to the values of u and w . On the other hand, I succeeded in separating u and w so as to obtain at once two differential equations, in one of which u appeared alone with the dilatation, while the other contained only w and the dilatation (see (28) and (29) later).

§ 4. There are two other points in Mr. Love's Treatise to which I should like to refer. In his art. 263 he substitutes the term *extensional* for *longitudinal*, adding in explanation, "The vibrations here considered are the 'longitudinal' vibrations of Lord Rayleigh's *Theory of Sound*. We have described them as 'extensional,' to avoid the suggestion that there is no lateral motion of the parts of the rod."

I am altogether in sympathy with the object which Mr. Love has in view (I expressed myself somewhat strongly on the point in (A) p. 296, and (C) pp. 351–2), but I doubt the wisdom of attempting to displace a term so generally adopted as *longitudinal*.

In the second matter I regret to find myself at variance with Mr. Love. Referring to transverse vibrations in a rod, he says on p. 124 of his vol. ii., "the boundary conditions at free ends cannot be satisfied exactly . . . as they can in the . . . extensional (longitudinal) modes." In reality, however, the boundary equations at a free end are not exactly satisfied in the case of longitudinal vibrations either by Pochhammer's solution or my own. The slip may be a purely verbal one on Mr. Love's part, but his readers might be led to accept the statement as accurate owing to a slight error in the expression for the shearing stress \widehat{zr} near the top of Mr. Love's p. 120. We find there

$$\widehat{zr} = 2\mu \left\{ \gamma A \frac{d}{dr} J_0(\kappa' r) + \dots \right\} e^{i(\gamma z + p t)},$$

where $\iota \equiv \sqrt{-1}$.

The correct expression (compare Mr. Love's second boundary equation on p. 118) is

$$\widehat{zr} = \iota \mu \left\{ 2\gamma A \frac{d}{dr} J_0(\kappa' r) + \dots \right\} e^{i(\gamma z + p t)}.$$

Owing to the omission of ι in the expression on p. 120 it looks as if \widehat{zr} vanished for the same values of z as the normal stress \widehat{zz} . In reality, as I showed in (A) p. 295, \widehat{zr} does not vanish over a terminal free section of radius a , but is of the order $r(r^2 - a^2)/l^3$, where r is the perpendicular on the axis. We are quite justified in neglecting \widehat{zr} when terms of order $(a/l)^3$ are negligible, but strictly speaking the solution is so far only an approximate one when the ends are free.

A New Method.

§ 5. In the Camb. Phil. Soc. Trans. vol. xv. pp. 313-337 I showed how the mean values of the strains and stresses might be obtained in any elastic solid problem independently of a complete solution. For isotropic materials I obtained (*l. c.* p. 318) three formulæ of the type

$$\begin{aligned} E \iiint \frac{d\gamma}{dz} dx dy dz = & \iiint \{Zz - \eta(Xx + Yy)\} dx dy dz \\ & + \iint \{Hz - \eta(Fx + Gy)\} dS, \quad (4) \end{aligned}$$

where α, β, γ are components of displacement, X, Y, Z of bodily forces, and F, G, H of surface forces. The volume integrals extend throughout the entire volume, and the surface integrals over the entire surface of the solid. As was explicitly stated in proving the results (*l. c.* p. 315), X, Y, Z may include 'reversed effective forces'

$$-\rho \frac{d^2\alpha}{dt^2}, \quad -\rho \frac{d^2\beta}{dt^2}, \quad -\rho \frac{d^2\gamma}{dt^2},$$

where ρ is the density.

In the present application there are no real bodily forces; we may also leave surface forces out of account, if we suppose that when one end of a rod is held, that end lies in the plane $z=0$.

Supposing the rod to vibrate with frequency $k/2\pi$, we have

$$X = -\rho \frac{d^2\alpha}{dt^2} = k^2\rho\alpha, \quad \&c.,$$

so that we replace (4) by

$$E \iiint \frac{d\gamma}{dz} dx dy dz = k^2\rho \iiint \{\gamma z - \eta(\alpha x + \beta y)\} dx dy dz, \quad (5)$$

and similarly with the two other equations of the same type.

The only other result required is one established in my

paper (B) ; viz., that the general solution of the elastic solid equations of motion in which the terms contain $\cos pz$ or $\sin pz$ consists of two independent parts. In the first, which alone applies to longitudinal vibrations, α and β are odd and γ an even function of x and y .

We may thus assume

$$\left. \begin{aligned} \alpha &= \cos kt \cos (pz - \epsilon) \{ A_1 x + A_1' y + A_3 x^3 + A_3' x^2 y \\ &\quad + A_3'' xy^2 + A_3''' y^3 + \dots \}, \\ \beta &= \cos kt \cos (pz - \epsilon) \{ B_1 x + B_1' y + B_3 x^3 + \dots \}, \\ \gamma &= \cos kt \sin (pz - \epsilon) \{ C_0 + C_2 x^2 + C_2' xy + C_2'' y^2 + \dots \}, \end{aligned} \right\} . (6)$$

where ϵ is a constant depending on the position of the origin of coordinates and the terminal conditions. It is obvious from various considerations that the same ϵ occurs in the values of α , β , γ . Certain relations must subsist between the constants A , B , C in the above expressions, in virtue of the body-stress equations, but we do not require to take any heed of these for our present purpose.

§ 6. As the validity of solutions in series has been a subject of contention in other elastic solid problems, some doubt may be entertained as to the results (6). I would be the last to deny the reasonableness of this, because I do not myself regard (6) as universally applicable.

According to my investigations, quantities such as $(A_3 x^3 / A_1 x)$ are of the order (greatest diameter/nodal length)², and the series become less rapidly convergent as (greatest diameter/nodal length) increases. In other words, increase either in (greatest diameter/rod length) or in the order of the "harmonic" of the fundamental note reduces the rapidity of convergence. The proper interpretation, however, to put on this is not that (6) is a wrong formula for *longitudinal* vibrations, but simply that under the conditions specified the vibrations tend to depart too widely from the longitudinal type. If we apply this solution the results deduced from it themselves tend to show the degree of rapidity of the convergence, and what we have to do is to keep our eye on the results and accept them only so long as they are consistent with rapid convergency.

Perhaps the following *résumé* of my views on this point may be useful :—

1. In obtaining (6) originally I employed the *complete* elastic solid equations for isotropic materials. In other cases where difficulties have arisen over expansion in series, they seem mainly due to the fact that the elastic solid equations have been whittled down in the first instance for purposes of

simplicity. When one omits terms in a differential equation for diplomatic reasons, the results may be perfectly satisfactory under certain limitations. Owing, however, to the mutilation of the differential equations, the resulting solutions are unlikely to contain within themselves any satisfactory indication of the limits to their usefulness. It is very much a case of running a steam-engine without a safety-valve.

2. When the bar is of circular section and isotropic, the series occurring in (6) are Bessel's functions of a well-known type, whose rapidity of convergence appears well ascertained under the normal conditions of the problem. When the section is circular, and the material not isotropic but symmetrical round the axis, the series, whose mathematical law of development I have obtained, converge to all appearance quite as rapidly as in the case of isotropy. The other cases of isotropic material—sections elliptical or rectangular—which I have considered present similar features; the only difference being that the rate of convergence diminishes with increase in any one dimension of the cross section.

3. If we suppose $k=0$, or the vibrations to be of infinite period, the solution must reduce to that for the equilibrium of a rod under uniform longitudinal traction. Now, in the case of equilibrium γ/z reduces to a constant, while α and β are linear in x and y for *all forms of cross section*. The commencing terms in series (6) are thus of the proper form under all conditions, and the form of the differential equations shows that if α , for instance, contains a term in x it must contain terms in x^3 , xy^2 , and other *integral* powers of x and y .

4. The general type of the differential equations is the same for all kinds of elastic material, isotropic or æolotropic, and the surface conditions are identical in all cases; thus the type of solution must always be the same. The results may become enormously lengthy for complicated kinds of æolotropy, but by putting a variety of the elastic constants equal to one another we must reduce the most complicated of these expressions to coincidence with the corresponding results for isotropy. Of course it does not follow that the convergence will be equally rapid for all materials. A large value of a Poisson's ratio in conjunction with an elongated dimension of the cross section may reduce the convergency so much as to throw the higher "harmonics" outside the pale of longitudinal vibrations.

5. The more the section departs from the circular form the less rapid in general is the convergence, and the larger the correction supplied by the second approximation. In fact the size of the correction is probably the best criterion

by which to judge of the limitations of our results. If the correction is large even for the fundamental note, it is pretty safe to conclude that the section is not one adapted for the ordinary type of longitudinal vibrations. If a section, for instance, were of an acutely stellate character, with a lot of rays absent and the centroid external to the material, I for one should be extremely chary of applying to it the ordinary formula.

§ 7. For definiteness let us consider the fixed-free vibrations, taking the origin of coordinates at the centroid of the fixed end. Our terminal conditions are

$$\begin{aligned} \gamma &= 0 \text{ when } z=0, \\ \widehat{z\gamma} &= 0 \quad ,, \quad z=l; \end{aligned}$$

the latter condition being the same thing as

$$\frac{d\gamma}{dz} = 0 \text{ when } z=l.$$

These conditions give at once

$$\epsilon = 0, \quad p = (2i + 1)\pi/2l,$$

and hence

$$\int_0^l pz \sin(pz - \epsilon) dz = \int_0^l \cos(pz - \epsilon) dz.$$

Take the axes of x and y along the principal axes of the cross section σ , so that

$$\begin{aligned} \iint xy \, dx \, dy &= 0, \\ \iint x^2 \, dx \, dy &= \kappa_2^2 \sigma, \quad \iint y^2 \, dx \, dy = \kappa_1^2 \sigma. \end{aligned}$$

Then, substituting from (6) in (5), we obtain at once

$$\begin{aligned} (Ep - k^2\rho/p)(C_0 + C_2\kappa_2^2 + C_2''\kappa_1^2 + \dots) \\ = -k^2\rho\eta(A_1\kappa_2^2 + B_1'\kappa_1^2 + \dots) \quad . \quad . \quad (7) \end{aligned}$$

The section is supposed small, *i. e.* terms in κ_1^2, κ_2^2 are small compared to C_0 , though large compared to the terms of orders κ_1^4 , &c., which are omitted in the above equation. Thus as a first approximation the coefficient of C_0 must vanish, or

$$k = p \sqrt{E/\rho}, \quad . \quad . \quad . \quad . \quad . \quad (1)$$

which is simply the ordinary frequency equation.

Treating the other two equations of the type (5) similarly,

we obtain the two results

$$E(A_1 + 3A_3\kappa_2^2 + A_3''\kappa_1^2 + \dots) = -k^2\rho \left\{ \frac{\eta}{p} (C_0 + C_2\kappa_2^2 + C_2''\kappa_1^2 + \dots) + \eta B_1'\kappa_1^2 - A_1\kappa_2^2 + \dots \right\}, \quad (8)$$

$$E(B_1' + B_3'\kappa_2^2 + 3B_3''\kappa_1^2 + \dots) = -k^2\rho \left\{ \frac{\eta}{p} (C_0 + C_2\kappa_2^2 + C_2''\kappa_1^2 + \dots) + \eta A_1\kappa_2^2 - B_1'\kappa_1^2 + \dots \right\}. \quad (9)$$

The terms not shown are of the order κ_1^4 , κ_2^4 , or higher powers of κ_1 and κ_2 . Combining (8) and (9) we get

$$E(A_1 - B_1') = k^2\rho(1 + \eta)(A_1\kappa_2^2 - B_1'\kappa_1^2) + \dots, \quad (10)$$

$$E(A_1 + B_1') = -2k^2\rho(\eta/p)(C_0 + C_2\kappa_2^2 + C_2''\kappa_1^2 + \dots) + (1 - \eta)k^2\rho(A_1\kappa_2^2 + B_1'\kappa_1^2) + \dots \quad (11)$$

To see the significance of (10) replace $k^2\rho$ by its approximate value p^2E , when we have

$$A_1 - B_1' = (1 + \eta) \{ A_1(p\kappa_2)^2 - B_1'(p\kappa_1)^2 \} + \dots \quad (12)$$

As we have seen, $p = (i + \frac{1}{2})\pi/l$; and thus, so long as i is not too large, $(p\kappa_2)^2$ and $(p\kappa_1)^2$ are in a thin rod small quantities of the orders $(\kappa_2/l)^2$ and $(\kappa_1/l)^2$. Hence we deduce from (12) as a first approximation

$$B_1' = A_1 \dots \dots \dots \quad (13)$$

This is all we require for our present purpose; but, in passing, it may be noted that as a second approximation we have

$$B_1' = A_1 \{ 1 + (1 + \eta)p^2(\kappa_1^2 - \kappa_2^2) \}.$$

The more the section departs from circularity—*i. e.* the more elongated it is in one direction—the greater is the difference between B_1' and A_1 . This and the fact that $i\kappa_1/l$ and $i\kappa_2/l$ must both remain small are useful indications of the limitations implied in the method of solution.

Employing (13) in (7) and (11) we have, neglecting smaller terms,

$$(E\rho - k^2\rho/p)(C_0 + C_2\kappa_2^2 + C_2''\kappa_1^2) = -k^2\rho\eta A_1(\kappa_2^2 + \kappa_1^2),$$

$$2k^2\rho(\eta/p)(C_0 + C_2\kappa_2^2 + C_2''\kappa_1^2) = -2EA_1.$$

Whence we deduce at once, without knowing anything of the constants C_2 , A_3 , &c.,

$$(E\rho - k^2\rho/p) \div (2k^2\rho\eta/p) = k^2\rho\eta(\kappa_2^2 + \kappa_1^2)/(2E).$$

Using in the small term (that containing k^4) the first approximation (1), we have

$$k^2\rho = E p^2 \{1 - \eta^2 p^2 (\kappa_1^2 + \kappa_2^2)\}; \quad . \quad . \quad . \quad (14)$$

and this, as

$$\kappa_1^2 + \kappa_2^2 = \kappa^2,$$

simply reduces to (3).

That the above proof is as satisfactory in every way as one based on ordinary elastic solid methods I should hesitate to maintain. Unless one knew beforehand a good deal about the problem there would, I fear, be considerable risk of misadventure.

§ 8. In illustrating the method in detail I have selected the case of isotropic material simply because I did not wish to frighten my readers. The assumption of isotropy almost invariably shortens the mathematical expressions, and generally also simplifies the character of the mathematical operations; and isotropic solids thus flourish in the text-books to a much greater degree than they do in nature. When, however, the mathematical difficulties are trifling, as in the present case, it seems worth while considering some less specialized material. I shall thus briefly indicate the application of the method to the case of material symmetrical with respect to the three rectangular planes of x, y, z , taken as in the previous example. In this case the stress-strain relations involve, on the usual hypothesis, nine elastic constants. Such quantities as Young's modulus or Poisson's ratio must be defined by reference to directions. Thus let E_1, E_2, E_3 denote the three principal Young's moduli, the directions 1, 2, 3 being taken along the axes of x, y, z respectively. There are six corresponding Poisson's ratios, each being defined by two suffixes, the first indicating the direction of the longitudinal pull, the second that of the contraction. For instance, η_{12} applies in the case of the contraction parallel to the y -axis due to pull parallel to the x -axis. The order of the suffixes is not immaterial, but there exist the following relations:—

$$\eta_{12}/E_1 = \eta_{21}/E_2; \quad \eta_{23}/E_2 = \eta_{32}/E_3; \quad \eta_{31}/E_3 = \eta_{13}/E_1. \quad (15)$$

The three equations answering to (4) are

$$E_3 \iiint \frac{d\gamma}{dz} dx dy dz = k^2 \rho \iiint \{\gamma z - \eta_{31}\alpha x - \eta_{32}\beta y\} dx dy dz, \quad (16)$$

$$E_1 \iiint \frac{d\alpha}{dx} dx dy dz = k^2 \rho \iiint \{\alpha x - \eta_{12}\beta y - \eta_{13}\gamma z\} dx dy dz, \quad (17)$$

$$E_2 \iiint \frac{d\beta}{dy} dx dy dz = k^2 \rho \iiint \{\beta y - \eta_{23}\gamma z - \eta_{21}\alpha x\} dx dy dz. \quad (18)$$

From the nature of the elastic solid equations the expressions for the displacements must be of the same general form as for isotropy, so that we may still apply the formulæ (6) for α , β , γ . Doing so, and following exactly the same procedure as in the case of isotropy, we obtain from (16), for any shape of section,

$$(E_3 p - k^2 \rho / p)(C_0 + \dots) = -k^2 \rho (\eta_{31} A_1 \kappa_2^2 + \eta_{32} B_1' \kappa_1^2) + \dots, \quad (19)$$

and from (17) and (18) as first approximations

$$A_1 / (\eta_{13} E_3 / E_1) = B_1' / (\eta_{23} E_3 / E_2) = -p(C_0 + \dots). \quad (20)$$

Thence we obtain at once

$$k^2 \rho = p^2 E_3 \left\{ 1 - p^2 E_3 \left(\frac{\eta_{31} \eta_{13}}{E_1} \kappa_2^2 + \frac{\eta_{32} \eta_{23}}{E_2} \kappa_1^2 \right) \right\}. \quad (21)$$

Employing (15) we give this the more elegant form

$$k^2 \rho = p^2 E_3 \left\{ 1 - p^2 (\eta_{31}^2 \kappa_2^2 + \eta_{32}^2 \kappa_1^2) \right\},$$

whence

$$k = p(E_3 / \rho)^{\frac{1}{2}} \left\{ 1 - \frac{1}{2} p^2 (\eta_{31}^2 \kappa_2^2 + \eta_{32}^2 \kappa_1^2) \right\}. \quad (22)$$

For a circular section of radius a

$$k = p(E_3 / \rho)^{\frac{1}{2}} \left\{ 1 - \frac{1}{8} p^2 a^2 (\eta_{31}^2 + \eta_{32}^2) \right\}. \quad (23)$$

For a rectangular section $2a \times 2b$, the side $2a$ being parallel to the x -axis,

$$k = p(E_3 / \rho)^{\frac{1}{2}} \left\{ 1 - \frac{1}{6} p^2 (a^2 \eta_{31}^2 + b^2 \eta_{32}^2) \right\}. \quad (24)$$

For a given size and shape of rectangle, the correction to the first approximation is largest when the longer side is that answering to the larger Poisson's ratio (for traction along the rod). Possibly experimental use might be made of this result in examining materials for æolotropy.

If the material, though not isotropic, be symmetrical in structure round lines parallel to the length of the rod,

$$\eta_{31} = \eta_{32} = \eta, \text{ say,}$$

and writing E for E_3 in (22) we reproduce the result (60) of paper (C).

The results (22), (23), and (24), so far as my knowledge goes, are absolutely new.

Extension of Earlier Results.

§ 9. My paper (A), like the corresponding investigation of Pochhammer, dealt only with a solid circular cylinder; but the same method is applicable to a hollow circular cylinder. For greater continuity I shall employ in the remainder of this paper the notation of paper (A).

The displacements are u outwards along r , the perpendicular on the axis, and w parallel to the axis, taken as that of z . Thomson and Tait's notation m, n for the elastic constants is employed. The frequency is $k/2\pi$ and the density ρ , as in the earlier part of this paper, and for brevity

$$k^2\rho/(m+n) = \alpha^2, \quad k^2\rho/n = \beta^2, \quad . . . \quad (25)$$

so that α and β have utterly different significations from their previous ones.

There being no displacement perpendicular to r , in a transverse section, the dilatation δ is given by

$$\delta = \frac{du}{dr} + \frac{u}{r} + \frac{dw}{dz} \quad (26)$$

It was shown in paper (A) that the following equations held

$$\frac{d^2\delta}{dr^2} + \frac{1}{r} \frac{d\delta}{dr} + \frac{d^2\delta}{dz^2} + \alpha^2\delta = 0, \quad \quad (27)$$

$$\frac{d^2u}{dr^2} + \frac{1}{r} \frac{du}{dr} - \frac{u}{r^2} + \frac{d^2u}{dz^2} + \beta^2u = -\frac{m}{n} \frac{d\delta}{dr}, \quad (28)$$

$$\frac{d^2w}{dr^2} + \frac{1}{r} \frac{dw}{dr} + \frac{d^2w}{dz^2} + \beta^2w = -\frac{m}{n} \frac{d\delta}{dz} . \quad (29)$$

Employing J and Y to represent the two solutions of Bessel's equation we find, as in paper (A), that the above equations are satisfied by

$$\delta = \cos kt \cos (pz - \epsilon) \{CJ_0(r(\alpha^2 - p^2)^{\frac{1}{2}}) + C'Y_0(r(\alpha^2 - p^2)^{\frac{1}{2}})\}, \quad (30)$$

$$u = \cos kt \cos (pz - \epsilon) \left[AJ_1(r(\beta^2 - p^2)^{\frac{1}{2}}) + A'Y_1(r(\beta^2 - p^2)^{\frac{1}{2}}) - \frac{m}{n} \frac{(\alpha^2 - p^2)^{\frac{1}{2}}}{\alpha^2 - \beta^2} \{CJ_1(r(\alpha^2 - p^2)^{\frac{1}{2}}) + C'Y_1(r(\alpha^2 - p^2)^{\frac{1}{2}})\} \right], \quad (31)$$

$$w = -\cos kt \sin (pz - \epsilon) \left[\{AJ_0(r(\beta^2 - p^2)^{\frac{1}{2}}) + A'Y_0(r(\beta^2 - p^2)^{\frac{1}{2}})\} \times \frac{(\beta^2 - p^2)^{\frac{1}{2}}}{p} + \frac{mp}{n(\alpha^2 - \beta^2)} \{CJ_0(r(\alpha^2 - p^2)^{\frac{1}{2}}) + C'Y_0(r(\alpha^2 - p^2)^{\frac{1}{2}})\} \right], \quad (32)$$

where A, A', C, C' are arbitrary constants to be determined by the surface conditions.

In reality $\alpha^2 - p^2$ is negative; but the properties of the J and Y Bessel functions which at present concern us are not affected thereby. $\beta^2 - p^2$, on the other hand, is positive.

§ 10. If a and b are the radii of the outer and inner cylindrical surfaces respectively, then from the conditions which hold over these surfaces we must have

$$\frac{du}{dz} + \frac{dw}{dr} = 0, \dots \dots \dots (33)$$

$$(m-n)\delta + 2n \frac{du}{dr} = 0, \dots \dots \dots (34)$$

when $r=a$, and when $r=b$.

As regards the terminal conditions we should have, following the ordinary view of longitudinal vibrations,

$$w=0 \text{ over a fixed end, } \dots \dots \dots (35)$$

$$\left. \begin{aligned} \widehat{zz} &\equiv (m-n)\delta + 2n \frac{dw}{dz} = 0, \\ \widehat{zr} &\equiv n \left(\frac{du}{dz} + \frac{dw}{dr} \right) = 0 \end{aligned} \right\} \text{over a free end.} \quad (36)$$

We have no means of satisfying these terminal equations by means of the present solution save by selecting suitable values for p and ϵ . Clearly if both ends $z=0$ and $z=l$ be fixed we accomplish our object by putting

$$\epsilon = 0, \quad p = i\pi/l.$$

If, however, $z=l$ be a free end, while $z=0$ is a fixed, we must have $\epsilon=0$ to satisfy the conditions of the fixed end; and this leaves us with

$$\begin{aligned} \widehat{zz} &\propto \cos pl, \\ \widehat{zr} &\propto \sin pl \end{aligned}$$

over the free end. This is the difficulty we have already indicated in § 4; and it is in no respect peculiar to hollow cylinders, and need not further concern us at present.

§ 11. In dealing with the surface conditions, brevity is effected by the use of the notation

$$\lambda \equiv \sqrt{\alpha^2 - p^2}, \quad \mu \equiv \sqrt{\beta^2 - p^2}, \quad \dots \dots (37)$$

whence

$$\alpha^2 - \beta^2 = \lambda^2 - \mu^2.$$

After simplifications, into which I need not enter, the elimination of A, A', C, C' from the four equations holding over the cylindrical surface supplies the determinantal equation

$$\begin{array}{l}
 (a\mu) \quad Y_1(a\mu) \quad - \frac{2p^2\lambda}{\alpha^2(\mu^2-p^2)} J_1(a\lambda) \quad - \frac{2p^2\lambda}{\alpha^2(\mu^2-p^2)} Y_1(a\lambda) \\
 (b\mu) \quad Y_1(b\mu) \quad - \frac{2p^2\lambda}{\alpha^2(\mu^2-p^2)} J_1(b\lambda) \quad - \frac{2p^2\lambda}{\alpha^2(\mu^2-p^2)} Y_1(b\lambda) \\
 (a\mu) \quad Y_1'(a\mu) \quad \frac{m-n}{2n\mu} J_0(a\lambda) + \frac{\lambda^2}{\alpha^2\mu} J_1'(a\lambda) \quad \frac{m-n}{2n\mu} Y_0(a\lambda) + \frac{\lambda^2}{\alpha^2\mu} Y_1'(a\lambda) \\
 (b\mu) \quad Y_1'(b\mu) \quad \frac{m-n}{2n\mu} J_0(b\lambda) + \frac{\lambda^2}{\alpha^2\mu} J_1'(b\lambda) \quad \frac{m-n}{2n\mu} Y_0(b\lambda) + \frac{\lambda^2}{\alpha^2\mu} Y_1'(b\lambda)
 \end{array} \Bigg| = 0. \tag{38}$$

This equation is true irrespective of the *relative* magnitudes of a and b . It constitutes a frequency equation supplying values of k which apply to the type of vibrations consistent with the surface conditions. If both ends of the rod be fixed there is no restriction to the absolute values of a/l and b/l ; but if one or both ends are free, such a restriction is really involved in the fact that unless ia/l and ib/l be both small— i being the order of the harmonic of the fundamental note under consideration—the failure to satisfy exactly the terminal condition

$$\widehat{zr} = 0$$

involves an inconsistency which cannot be allowed.

§ 12. The case of a thick rod fixed at both ends is of little physical interest, and the treatment of (38) in its utmost generality would involve grave mathematical difficulties. I thus limit my attention to the case when ia/l and ib/l are both small. This implies that $a\lambda$, $b\lambda$, $a\mu$, and $b\mu$ are all small. Thus in dealing with the various Bessel functions we may use the following approximations*, which hold so long as the variable x is small,

$$\left. \begin{array}{l}
 J_0(x) = 1 - x^2/4, \\
 J_1(x) = \frac{1}{2}x(1 - x^2/8), \\
 J_1'(x) = \frac{1}{2}(1 - \frac{3}{8}x^2), \\
 Y_0(x) = (1 - x^2/4) \log x + x^2/4, \\
 Y_1(x) = \frac{x}{2}(1 - x^2/8) \log x - x^{-1} - x/4, \\
 Y_1'(x) = \frac{1}{2}(1 - \frac{3}{8}x^2) \log x + x^{-2} + \frac{1}{4}.
 \end{array} \right\} \quad . \quad (39)$$

Retaining only the principal terms in (38), we are of course led at once to the first approximation (1). Again, if (1) held exactly we should find

$$\left. \begin{array}{l}
 \alpha^2 = p^2 n(3m-n) \div m(m+n), \\
 \lambda^2 = -p^2(m-n)^2 \div m(m+n), \\
 \mu^2 - p^2 = p^2(m-n)/m;
 \end{array} \right\} \quad . \quad (40)$$

* Cf. Gray and Mathews' 'Treatise on Bessel Functions,' pp. 11, 22, &c.

and to a first approximation

$$-\frac{J_1(a\lambda)}{J_1(a\mu)} \frac{2p^2\lambda}{\alpha^2(\mu^2-p^2)} = -\frac{2p^2\lambda^2}{\alpha^2\mu(\mu^2-p^2)} = \frac{2}{\mu} \frac{m(m-n)}{n(3m-n)},$$

$$\frac{m-n}{2n\mu} \frac{J_0(a\lambda)}{J_1'(a\mu)} + \frac{\lambda^2}{\alpha^2\mu} \frac{J_1'(a\lambda)}{J_1'(a\mu)} = \frac{2(m-n)}{2n\mu} + \frac{\lambda^2}{\alpha^2\mu} = \frac{2m(m-n)}{\mu n(3m-n)},$$

and similarly if a be replaced by b .

We thus see that the third column in the determinant (38) is such that each principal term in it is obtained by multiplying the principal term in the same row in the first column by the same constant $2m(m-n) \div \{\mu n(3m-n)\}$. Now if one column of a determinant is obtainable by multiplying another column by a constant that determinant vanishes. It is thus at once clear that in proceeding even to a second approximation we need retain only the principal terms in the second and fourth columns of (38). This removes what seemed at first sight a formidable obstacle, viz. the occurrence of the logs in the expressions for $Y_0, Y_1,$ and Y_1' .

§ 13. For further simplification of the determinant multiply each term by 2, and divide the first and second rows by $a\mu$ and $b\mu$ respectively. Then for the second row write the difference between the first and second rows, and for the fourth row the difference between the third and fourth rows, and multiply the resulting rows by $b^2/(\alpha^2-b^2)$. Finally multiply the second column by $\alpha^2\mu^2/2$, the third column by $\mu\alpha^2$, and the fourth column by $\alpha^2\mu\alpha^2/2$. We thus reduce (38) to the easily manageable form

$1 - \frac{1}{8}a^2\mu^2$	-1	$-\frac{2\lambda^2 p^2}{\mu^2 - p^2} (1 - \frac{1}{8}a^2\lambda^2)$	$\frac{2p^2}{\mu^2 - p^2}$	(41)
$\frac{1}{8}b^2\mu^2$	-1	$-\frac{\lambda^4 p^2 b^2}{4(\mu^2 - p^2)}$	$\frac{2p^2}{\mu^2 - p^2}$	
$1 - \frac{3}{8}a^2\mu^2$	1	$\lambda^2 + \alpha^2 \frac{m-n}{n} - \frac{\alpha^2 \lambda^2}{8} \left(3\lambda^2 + 2\alpha^2 \frac{m-n}{n} \right)$	1	
$\frac{3}{8}b^2\mu^2$	1	$\frac{1}{8}b^2\lambda^2 \left(3\lambda^2 + 2\alpha^2 \frac{m-n}{n} \right)$	1	

After algebraic reduction, use being made in the secondary terms of the first approximation results (1), (40), &c., we easily deduce from (41)

$$k^2 = \frac{p^2}{\rho} \frac{n(3m-n)}{m} \left\{ 1 - \frac{1}{2}p^2 \left(\frac{m-n}{2m} \right)^2 (\alpha^2 + b^2) \right\}, \dots \quad (42)$$

whence

$$k = p(E/\rho)^{\frac{1}{2}} \left\{ 1 - \frac{1}{2}p^2 \eta^2 \frac{\alpha^2 + b^2}{2} \right\} \dots \dots \quad (43)$$

In a hollow circular section the radius of gyration round the perpendicular to the plane through the centre is given by

$$\kappa^2 = (a^2 + b^2)/2,$$

so that (43) is in agreement with (3) and (22).

The fact that (43) is merely a special case of (3) or (22) may seem to indicate that our separate treatment of the hollow cylinder, or tube, is quite unnecessary. I can only say that having regard to the methods by which (3) and (22) were arrived at—more especially to the fact that in establishing (6) I was dealing with solid cylinders—I had long felt the desirability of an independent investigation.

§ 14. The complete determination of the constants A, A', C, C' , and of the several displacements, strains, and stresses to the degree of accuracy assumed in (43), though not a very arduous labour, would require more time than seems warranted by the physical interest of the problem. I thus confine my further remarks to the form of the longitudinal displacement w . Substituting their approximate values for the J 's and Y 's from (39) in (32), we find

$$\begin{aligned} pw/\mu \cos kt \sin (pz - \epsilon) = & \\ & -A(1 - \frac{1}{4}\mu^2 r^2) - A' \left\{ (1 - \frac{1}{4}\mu^2 r^2) \log \mu r + \frac{1}{4}\mu^2 r^2 \right\} \\ & + \frac{Cp^2}{\mu\alpha^2} (1 - \frac{1}{4}\lambda^2 r^2) + \frac{C'p^2}{\mu\alpha^2} \left\{ (1 - \frac{1}{4}\lambda^2 r^2) \log \lambda r + \frac{1}{4}\lambda^2 r^2 \right\}. \end{aligned} \quad (44)$$

Now, considering only their principal terms, it is easily seen that A'/A and C'/C are both of the order $(p^2 ab)^2$. Thus, to the present degree of approximation, we may leave the A' and C' terms in w out of account. Also confining ourselves to principal terms, we easily find

$$\frac{-A}{2(m-n)} = \frac{Cp^2/\mu\alpha^2}{m+n}.$$

Hence, employing the two last of equations (40), we deduce

$$\begin{aligned} \frac{1}{4} \{ A\mu^2 - (Cp^2/\mu\alpha^2)\lambda^2 \} \div \{ -A + Cp^2/\mu\alpha^2 \} \\ = -\frac{m-n}{4m} p^2 = -\frac{1}{2}\eta p^2. \end{aligned}$$

We thus have from (44), to the degree of approximation reached in (43),

$$w = w_0 \cos kt \sin (pz - \epsilon) (1 - \frac{1}{2}\eta p^2 r^2), \quad \dots \quad (45)$$

where w_0 is a constant which depends on the amplitude of the vibration.

The expression (45) for w is exactly the same as I found

in my earlier papers for solid cylinders; the r^2 term representing one of the additions I deem it necessary to make to Lord Rayleigh's assumed type of vibration.

The paraboloidal form of cross section, met with except at nodes or when $\cos kt$ vanishes, seems to me an interesting feature of the longitudinal type of vibrations. Possibly, observations on light reflected from a polished terminal face might lead a skilled experimentalist to interesting conclusions as to the value of η .

It should, however, be borne in mind that, inasmuch as the terminal condition $\widehat{zr}=0$ is not exactly satisfied by the above solution in fixed-free vibrations, there may be a slight departure from the theoretical form in the immediate neighbourhood of a free end.

§ 15. The result (43) is true irrespective of the relative magnitudes of b and a . If b/a be very small, the correctional term is the same as for a solid cylinder of the same external radius. If, on the other hand, b/a be very nearly unity, or the cylinder take the form of a thin-walled tube, we have

$$k = p(E/\rho)^{\frac{1}{2}}(1 - \frac{1}{2}p^2\eta^2a^2). \quad \dots \quad (46)$$

The correctional term is here twice as great as in a solid cylinder of radius a .

§ 16. An experimental investigation into the influence of the shape and dimensions of the cross-section on the frequency of longitudinal vibrations is certainly desirable. In comparing the results of such an investigation with the theoretical results here determined, several considerations must, however, be borne in mind.

Statical and dynamical elastic moduli are to some extent different, so that the value of E occurring in (2) or (3) is not that directly measured by statical experiments*. In other words the difference between the observed frequency of the fundamental vibration in a fixed-free bar, and the frequency calculated from the ordinary formula

$$k/2\pi = (1/4l) \sqrt{E/\rho},$$

if E be determined directly by statical experiments, is not to be wholly attributed to the defect of the ordinary first approximation formula. Again, it must be remembered that E varies †, often to a very considerable extent, in material nominally the same; so that the difference of pitch observed

* See Lord Kelvin's Encyclopædia article on Elasticity, § 75, or Todhunter and Pearson's 'History,' vol. iii. art. 1751.

† For the effects of possible variation in the material throughout the bar, see the Phil. Mag. for Feb. 1886, pp. 81-100.

in different rods cannot without further investigation be safely ascribed to differences in the area or shape of their cross-sections. Further, elastic moduli may alter under mechanical treatment, so that it would be unsafe to assume if a hollow bar were further hollowed or were altered in shape, that its Young's modulus would remain unaffected.

If it were possible to measure with sufficient accuracy the frequency of the fundamental note and several of its "harmonics" in a single rod, one would have a more certain basis of comparison with the theoretical results. Even in this case, however, there is the consideration that in practice the rod must be supported in some way, and this is likely to introduce some constraint not accurately represented by the theoretical conditions. Again, reaction between the vibrating rod and the surrounding medium may not be absolutely without influence on the pitch*.

I mention these difficulties because their recognition may prevent a considerable waste of time on the part of anyone engaged in experiments on the subject.

Though somewhat of a side issue, it may be worth remarking that the correction factor $1 - \frac{1}{2}p^2\eta^2\kappa^2$ for the frequency in isotropic material contains no elastic constant except Poisson's ratio. Thus observations made on rods differing only in material might throw some light on the historic question whether η is or is not the same for all isotropic substances.

The discussion of equations (6) and of the experimental side of the problem has been largely expanded at the suggestion of the Society's referee.

XXX. *Some Experiments on Artificial Mirages and Tornadoes.* By R. W. WOOD †.

[Plate III.]

IN an article published in 'Nature' for Nov. 19, 1874, Prof. Everett, in discussing the phenomenon of mirage, showed that the condition necessary for the formation of sharp images in a horizontally stratified atmosphere, is a plane of maximum refractive index, the optical density decreasing as we go above or below this plane in direct proportion to the distance.

A horizontal or nearly horizontal ray will be bent towards and cross the plane of maximum density, where it changes its curvature and is again bent towards the plane, which it

* Cf. Lamb, *Memoirs and Proceedings Manchester Phil. Society*, vol. xlii. part iii. 1898.

† Communicated by the Author.

may thus cross again and again, traversing a path which is approximately a sine curve.

While showing the curve-trajectory of a ray of light in a vessel filled with brine, the density of which increased with the depth, it occurred to me that by properly regulating the refractive index of the liquid, the ray might be made to traverse a sine curve.

Some attempts in this direction were so successful, and yielded such beautiful experiments for the lecture-room, that it seems worth while to publish them, together with some photographs of the trajectories, although, as I have since learned, very similar experiments have already been described by Wiener ("Gekrümmte Lichtstrahlen," *Wied. Annalen*, xlix. p. 105).

For the liquid I adopted an arrangement very similar to the one described by Prof. Everett for obtaining mirage in a rectangular tank.

A trough was first made of plate glass, about 50 cms. long, 10 cms. high, and 2 cms. wide. This was filled to the depth of 3 cms. with a concentrated solution of alum. By means of a pipette, of the form shown in Pl. III. fig. 1, water containing about 10 per cent. of alcohol was carefully deposited on the alum solution to a depth of 3 cms. The addition of the alcohol brings up the refractive index of the water, and is necessary for reasons that will be spoken of presently. As a liquid of high index, with a specific gravity intermediate between that of the other two liquids, I used, instead of sugar and whiskey, a mixture of glycerine and 85 per cent. alcohol, the right proportions being easily found by experiment.

The mixture should float on the alum solution and sink in the water, and is introduced between the two layers by means of the pipette at the end of the trough through which the ray is to enter. A layer about 3 cms. in thickness will be found about right.

All three of the solutions should be first acidified with a few drops of sulphuric acid, and rendered fluorescent with quinine.

The difference in surface-tension between the two upper layers may give some trouble: when the pipette is withdrawn it may draw a thread of the glycerine and alcohol mixture up through the water, and a complete upsetting of the layers occur as a result of the forces of surface-tension.

This invariably happens when alcohol is not added to the water, and can be remedied either by the addition of water to the glycerine mixture or of more alcohol to the water. It is a good plan in withdrawing the pipette to pull it out slowly in a very oblique direction, in order that the heavy liquid may be washed off before the tube reaches the surface.

The three layers may now be cautiously stirred to hasten the diffusion, after which they should be allowed to rest a few minutes until the striæ have disappeared.

If now a beam of light from an arc-lamp, made parallel by means of a condensing-lens, be thrown obliquely into one end of the trough, it will be seen to traverse the liquid in the form of a most beautiful blue wave, the curvature of which varies with the angle at which the ray enters. Rays of light travelling in sine curves are shown in figs. 2 and 3, which were photographed directly from the trough.

Prof. Everett showed in his paper that a parallel or slightly divergent ray entering a medium of this description would converge to a linear focus, and then successively diverge and converge to conjugate foci. This phenomenon is shown in fig. 4, which is a photograph of the trough with a rather wide beam of horizontal parallel light entering the end. This experiment I have never seen described, though Exner has shown that the eyes of some insects operate in a similar manner, the visual organ consisting of a transparent cylindrical body, the axis of which has a high refractive index, while as we approach the surface the optical density decreases continuously.

The beautiful miniature desert-mirages that I have witnessed on the level city pavements of San Francisco (see letter and photograph in 'Nature' for Oct. 20, 1898), suggested to me the idea of reproducing this phenomenon on a small scale in the class-room.

Although I have already described very briefly an experiment of this nature, I will repeat the description now somewhat more in detail. Three or four perfectly flat metal plates, each one about a metre long and 30 cms. wide, should be mounted end to end on iron tripods and accurately levelled. The plates should be thick enough not to buckle when heated, say 0.5 cm. I have used plaster plates, made by casting plaster of Paris on plate glass, with some success, though they are fragile and not very durable.

Probably plates of slate would serve admirably, since they will stand a fair amount of heating, and can be obtained very flat and smooth.

The plates must be thickly sprinkled with sand to destroy all traces of reflexion at grazing incidence, and the sand surface should appear perfectly level when looked along from a point just above its plane. On the absolute flatness of the desert depends the successful working of the experiment; therefore too much care cannot be given to the adjustment of the plates. An artificial sky must be formed at one end of the desert. If the experiment is being performed at night, a

sheet of thin writing-paper with an arc-lamp behind it works very well, but a large mirror set in a window and reflecting the sky is better, when daylight is to be had.

Between the sky and the desert a small range of mountains, cut out of pasteboard, should be set up. The individual peaks should be from 1 to 2 cm. high, and the valleys between them should be only a trifle above the level of the desert. The general arrangement is shown in fig. 5.

The plates are now heated by means of a row of burners, which should be moved about from time to time in order to prevent overheating any one place.

If now we look along the desert, holding the eye only a trifle above the level of the sand, we shall see the mountains sharply outlined against the sky: as the temperature rises a lake begins to form in front of the mountain-chain, and in a few moments the inverted images of the peaks appear as if reflected in the water. If the eye be depressed a trifle, the base of the mountain-chain vanishes completely in the illusory lake, which now appears as an inundation. These appearances are shown in fig. 6, the photographs having been taken of the actual mirage on the artificial desert. The first of the three shows the appearance when the plates are cold, the second the apparent lake with the images of the peaks in the water, and the third the vanishing of the lower portions of the range. Two or three palm-trees, cut out of paper, were stuck up to add to the effect. Vertical magnification can also be shown on the hot desert: if the mountains are removed and a small marble be laid on the sand at the farther end of the desert, it will be found that if the eye be brought into the right position, the circular outline will change into an ellipse, and as the eye is lowered the image will contract to a point and eventually disappear. The magnification in this case is of course due to the running together of the direct and refracted images. I have observed similar cases in looking across our lake, when the water was warm and the air cold, patches of snow on the opposite shore, too small to be visible to an eye several metres above the level of the lake, coming out very distinctly when one walked down a bank to the water's edge.

The atmospheric conditions existing when mirages of this description are observed are such as give rise to the dust-whirls, so often seen on the American desert, and when existing on a larger scale, to tornadoes. There seemed no reason why these whirlwinds should not be produced on a small scale as well as the mirages. One of the metal plates was sprinkled with precipitated silica and heated with a few burners: in a few minutes most beautiful little whirlwinds

began to run about over the surface, spinning the fine powder up in funnel-shaped vortices, which lasted sometimes ten or fifteen seconds. The silica powder must be made by igniting the gelatinous precipitate formed when silicon tetrafluoride is conducted into water. The commercial article is not sufficiently light and mobile.

Whirls formed in this way cannot be seen by a large audience, however, and I accordingly sought some way of making them on a larger scale. The plate was well heated after removing the silica and then dusted with sal-ammoniac: dense clouds of white vapour immediately arose from the hot surface, and presently in the centre there mounted to a height of about 2 metres a most perfect miniature tornado of dense smoke. By placing the plate in the beam of a lantern in a dark room, the whirls can be shown to a class in a large lecture-room. I find that it is best to put on the sal-ammoniac first and then heat the plate: the vortices then come off the plate almost continuously, and often persist for some time.

An instantaneous photograph of one of these tornadoes was taken in bright sunshine, and is reproduced in fig. 7.

This method of showing atmospheric vortices seems far preferable to the old way of forming them, by means of a rapidly whirling drum with cross partitions, as the whirls are produced by the same causes and under the same conditions that they are in nature.

Physical Laboratory
of the University of Wisconsin,
Madison, Nov. 20.

XXXI. *On the Thermal Properties of Normal Pentane.* By
J. ROSE-INNES, M.A., B.Sc., and SYDNEY YOUNG, D.Sc.,
F.R.S.*

IN the year 1894 an experimental investigation of the relations between the temperatures, pressures, and volumes of Isopentane, through a very wide range of volume, was carried out by one of us, and the results were published in the Proc. Phys. Soc. xiii. pp. 602-657. It was there shown that the relation $p = bT - a$ at constant volume (where a and b are constants depending on the nature of the substance and on the volume) holds good with at any rate but small error from the largest volume (4000 cub. cms. per gram) to the smallest (1.58 cub. cms. per gram).

In the neighbourhood of the critical volume (4.266 cub. cms.), and at large and very small volumes, the observed deviations were well within the limits of experimental error

* Communicated by the Physical Society: read December 9, 1898.

but at intermediate volumes they were somewhat greater, and, as they exhibited considerable regularity, it is a question whether they could be attributed entirely to errors of experiment. In any case, the relation may be accepted as a close approximation to the truth.

A quantity of pure normal pentane having been obtained by the fractional distillation of the light distillate from American petroleum, it was decided to carry out a similar investigation with this substance; but, as it had been found that isopentane vapour at the largest volumes behaves practically as a normal gas, it was not considered necessary to make the determinations through so wide a range of volume.

The method employed for the separation of the normal pentane from petroleum has been fully described in the *Trans. Chem. Soc.* 1897, lxxi. p. 442; and the vapour-pressures, specific volumes as liquid and saturated vapour, and critical constants have been given in the same journal (p. 446).

The data for the isothermals of normal pentane were obtained by precisely the same experimental methods as in the case of isopentane, and reference need, therefore, only be made to the previous paper (*loc. cit.*).

There were four series of determinations; and particulars as to the mass of pentane, and the data obtained in each series are given below:—

Series.	Mass of Normal Pentane.	Data obtained.
I.	gram. ·10922	Volumes of liquid to critical point; volumes above critical temperature to 280°.
II.	·02294	Volumes of unsaturated vapour from 140° to critical point; volumes above critical point to 280°.
III.	·005858	Volumes of vapour at and above 80°.
IV.	·001845	Volumes of vapour at and above 40°.

The correction for the vapour-pressure of mercury was made in the same way as with isopentane: when liquid was present it was assumed that the mercury vapour exerted no pressure; in Series I., above the critical point, one-fourth of the maximum vapour-pressure of mercury was subtracted; in Series II. one-half; in Series III. three-fourths; and in Series IV. the full pressure.

The volumes of a gram of liquid and unsaturated vapour are given in the following table.

Volumes of a Gram of Liquid and of Unsaturated Vapour.

SERIES I.

Temp.	Pressure. millim.	Volume. cub. cm.	Temp.	Pressure. millim.	Volume. cub. cm.	Temp.	Pressure. millim.	V lume. c u . cm			
130°.	7023*	2.022	170°. (cont.)	29270	2.269	200°. (cont.)	26910	3.329			
	8194	2.018		31990	2.250		27670	3.136			
	11430	2.008		35040	2.230		29350	2.944			
	15100	1.998		38270	2.211		30820	2.847			
	18610	1.989		42170	2.191		33060	2.751			
	22630	1.979		46180	2.172		36260	2.655			
	26810	1.969		50760	2.154		41090	2.558			
	31010	1.959		55660	2.135		46560	2.482			
	35560	1.950		19340	2.580		49980	2.443			
	40280	1.940		20110	2.557		51920	2.424			
	45520	1.930		20770	2.538		54060	2.405			
	50450	1.921		21570	2.519		28410	6.055			
	140°.	8507*		2.094	180°.		22470	2.500	210°.	28790	5.666
		9927		2.089			23420	2.481		29180	5.274
10580		2.085	24570	2.462		29530	4.883				
13230		2.075	25730	2.443		29920	4.492				
15730		2.066	27200	2.423		30400	4.106				
18280		2.056	28550	2.404		31160	3.716				
21300		2.046	30230	2.384		32660	3.330				
24140		2.036	32060	2.365		34200	3.137				
27300		2.027	33970	2.346		36870	2.945				
30670		2.018	36240	2.327		39010	2.848				
34610		2.008	38630	2.307		41970	2.752				
38340		1.999	41100	2.288		46070	2.656				
42710		1.989	44280	2.269		49360	2.598				
46880		1.979	47430	2.250		51950	2.559				
150°.	11380*	2.172	190°.	50830	2.231	220°.	54940	2.520			
	14680	2.153		54400	2.211		31010	6.056			
	18770	2.133		22490	2.900		31610	5.667			
	22830	2.114		22750	2.866		32270	5.275			
	27840	2.095		23180	2.827		32920	4.884			
	33180	2.075		23690	2.789		33670	4.493			
	39100	2.056		24310	2.750		34630	4.107			
	45700	2.037		25110	2.712		36030	3.717			
	53080	2.018		26100	2.673		38540	3.331			
	160°.	14060		2.272	200°.		27230	2.635	230°.	40790	3.138
		14330		2.268			28630	2.596		44510	2.946
		16670		2.249			30340	2.558		47320	2.849
		19250		2.229			32340	2.520		51110	2.752
		22000		2.210			34780	2.481		56010	2.657
25350		2.191	37650	2.443		33630	6.058				
29010		2.172	41060	2.404		34420	5.669				
32900		2.153	43110	2.385		35320	5.277				
37460		2.134	45310	2.366		36320	4.885				
42200		2.115	47620	2.346		37460	4.495				
47860		2.095	50200	2.327		38930	4.108				
53780		2.076	52950	2.308		40960	3.718				
170°.		16560	2.398	200°.		25720	6.053	240°.		42530	3.525
		17520	2.384			25890	5.665			44530	3.331
	19020	2.364	26030		5.273	47610	3.139				
	20660	2.345	26100		4.881	49680	3.042				
	22520	2.326	26190		4.491	52410	2.946				
	24460	2.307	26250		4.105	55850	2.850				
	26630	2.288	26400		3.715	36240	6.059				

* Pressure below vapour-pressure.

SERIES I. (continued).

Temp.	Pressure. millim.	Volume. cub. cm.	Temp.	Pressure. millim.	Volume. cub. cm.	Temp.	Pressure. millim.	Volume. cub. cm.
240°. (cont.)	37310	5·670	250°. (cont.)	45160	4·497	270°.	43780	6·064
	38430	5·278		47720	4·110		45570	5·675
	39770	4·886		49390	3·915		47600	5·282
	41350	4·496		51370	3·720		49990	4·890
	43310	4·109		53890	3·527		51320	4·695
	46170	3·719		260°. 41260	6·062		52890	4·499
250°.	48150	3·526	42850	5·673	54600	4·306		
	50870	3·332	44590	5·281	280°. 46310	6·065		
	54160	3·140	46530	4·889	48350	5·676		
	38810	6·061	49020	4·498	50620	5·283		
	40110	5·672	50420	4·304	51960	5·087		
	41510	5·279	52190	4·111	53300	4·891		
	43230	4·888	54090	3·916	54930	4·696		
					56810	4·500		

SERIES II.

Temp.	Pressure. millim.	Volume. cub. cm.	Temp.	Pressure. millim.	Volume. cub. cm.	Temp.	Pressure. millim.	Volume. cub. cm.
140°.	8866	30·61	200°. (cont.)	18460	14·93	240°. (cont.)	14570	25·13
	9055	29·70		19160	14·01		15530	23·27
	9255	28·77		19880	13·10		16600	21·41
	9466	27·85		20660	12·18		17810	19·56
	9682	26·93		21470	11·27		19220	17·71
	9886	26·00		22300	10·35		20380	16·32
160°.	9322	29·71	220°.	23130	9·44	21730	14·95	
	10570	26·94		23950	8·52	22710	14·03	
	11100	25·08		24720	7·61	23750	13·11	
	11700	23·22		25330	6·69	24910	12·19	
	12340	21·36		25620	6·23	26160	11·28	
	13040	19·52		11960	29·76	27560	10·36	
180°.	13420	18·60		12930	26·98	29070	9·45	
	13790	17·67		13720	25·11	30700	8·53	
	10550	29·73		14580	23·25	32570	7·61	
	11380	26·96		15560	21·39	34670	6·70	
	12000	25·09		16660	19·55	35790	6·24	
	12690	23·23		17900	17·70	36990	5·78	
	13450	21·37	18950	16·31	38330	5·32		
	14280	19·53	20100	14·94	39830	4·87		
	15200	17·68	20950	14·02	41730	4·41		
	15700	16·76	21850	13·10	260°. 13340	29·79		
	16220	15·84	22810	12·19	14500	27·01		
	16770	14·93	23850	11·27	15410	25·14		
200°.	17320	14·01	24950	10·35	16440	23·28		
	17890	13·09	26140	9·44	17610	21·42		
	18460	12·17	27380	8·52	18940	19·57		
	19010	11·26	28720	7·61	20480	17·72		
	11260	29·75	30080	6·69	21810	16·33		
	12160	26·97	30720	6·23	23300	14·95		
	12870	25·10	31440	5·78	24410	14·04		
	13640	23·24	32160	5·32	25620	13·12		
	14510	21·38	32990	4·86	26960	12·20		
	15470	19·54	33900	4·40	28460	11·28		
	16570	17·69	240°. 12650	29·77	30090	10·36		
	17480	16·30	13740	27·00	31900	9·45		

SERIES II. (continued).

Temp.	Pressure mill'im.	Volume cub. cm.	Temp.	Pressure millim.	Volume cub. cm.	Temp.	Pressure. millim.	Volume. cub. cm.
260°. (cont.)	33970	8.53	280°. (cont.)	16210	25.15	280°. (cont.)	30600	11.29
	36340	7.62		17320	23.29		32550	10.37
	39120	6.70		18580	21.43		34680	9.46
	40630	6.24		20080	19.58		37130	8.54
	42360	5.78		21710	17.73		39980	7.62
	44370	5.32		23160	16.34		43400	6.70
	46640	4.87		24810	14.96		45350	6.24
280°.	49650	4.41	26050	14.05	47680	5.79		
	13980	29.80	27410	13.12	50280	5.32		
	15230	27.02	28940	12.21	52150	5.05		
					54120	4.78		

SERIES III.

Temp.	Pressure. millim.	Volume. cub. cm.	Temp.	Pressure. millim.	Volume. cub. cm.	Temp.	Pressure. millim.	Volume. cub. cm.
80°.	2371	116.11	140° (cont.)	8325	33.32	200° (cont.)	13140	24.40
	2441	112.50		9040	29.74		13930	22.62
	2510	108.90		9435	27.95		240°. 3631	116.59
	2586	105.29	9860	26.16	3988	105.72		
	2666	101.64	160°.	3015	116.35	4276	98.40	
2708	99.83	3301		105.50	4603	91.10		
2537	116.17	3532		98.20	4980	83.83		
2770	105.34	3795		90.91	5428	76.61		
2955	98.05	4092		83.65	5958	69.34		
100°.	3166	90.77	4448	76.45	6426	63.91		
	3405	83.52	4859	69.20	6970	58.54		
	3681	76.33	5231	63.78	7372	54.95		
	4006	69.09	5652	58.42	7823	51.34		
	4190	65.50	5979	54.83	8362	47.75		
	4398	61.90	6324	51.23	8965	44.16		
	120°.	2701	116.23	6733	47.65	9677	40.57	
		2951	105.39	7192	44.07	10500	37.00	
		3152	98.10	7685	40.49	11480	33.41	
		3376	90.82	8284	36.92	12650	29.82	
3638		83.56	8977	33.34	13330	28.02		
3940		76.37	9795	29.76	14090	26.23		
4294		69.13	10260	27.97	14920	24.42		
4607		63.71	10770	26.17	15870	22.64		
4960		58.36	11310	24.37	280°.	3933	116.71	
5234		54.78	11890	22.59		4337	105.83	
5531	51.18	200°.	3317	116.47		4656	98.50	
5859	47.60		3642	105.61		5022	91.19	
6233	44.02		3896	98.30		5440	83.92	
6639	40.44		4190	91.01		5936	76.68	
140°.	2861		116.29	4533		83.74	6511	69.41
	3129		105.45	4927		76.53	7024	63.98
	3342		98.15	5401		69.27	7634	58.60
	3587		90.87	5812		63.85	8074	55.00
	3870		83.60	6299	58.48	8596	51.39	
	4197		76.41	6665	54.89	9187	47.80	
	4577	69.16	7084	51.29	9878	44.20		
	4920	63.75	7554	47.70	10670	40.61		
	5316	58.39	8066	44.12	11600	37.04		
	5607	54.80	8678	40.53	12700	33.44		
5943	51.21	9387	36.96	14050	29.85			
6309	47.63	10240	33.37	14830	28.05			
6717	44.05	11240	29.79	15690	26.25			
7179	40.47	11810	27.99	16680	24.45			
7708	36.90	12440	26.20	17800	22.66			

SERIES IV.

Temp.	Pressure. millim.	Volume. cub. cm.	Temp.	Pressure. millim.	Volume. cub. cm.	Temp.	Pressure. millim.	Volume. cub. cm.
40°.	858	299.3	120°.	928	357.6	200°	2415	162.8
	869	293.5		989	334.6	(cont.)	2588	151.5
60°.	857	322.6		1061	311.5		2788	140.1
	889	311.0		1143	288.4		3024	128.7
	956	287.9		1237	265.3		3302	117.4
	1034	264.9		1350	242.5		3458	111.6
	1125	242.1		1485	219.5		3632	106.0
	1236	219.1		1604	202.3		3830	100.2
	1299	207.7		1745	185.3		4049	94.6
	1370	196.3		1854	173.9	240°.	1217	358.7
	1447	185.0		1977	162.5		1299	335.7
	1534	173.7		2116	151.1		1394	312.4
	1580	168.0		2276	139.8		1502	289.3
80°.	882	334.3		2463	128.4		1631	266.1
	946	311.2		2680	117.1		1782	243.2
	1019	288.1		2807	111.4		1964	220.2
	1102	265.0		2946	105.7		2126	202.9
	1200	242.2		3096	100.0		2318	185.9
	1319	219.3		3264	94.4		2464	174.5
	1424	202.1	160°.	1025	357.9		2629	163.0
	1548	185.1		1093	335.0		2821	151.6
	1642	173.7		1175	311.8		3042	140.2
	1748	162.3		1264	288.7		3301	128.8
	1868	151.0		1371	265.6		3609	117.5
	2006	139.6		1497	242.7		3783	111.7
	2167	128.3		1647	219.7		3975	106.1
	2356	117.0		1783	202.5		4191	100.3
	2463	111.3		1939	185.5		4430	94.7
	2579	105.6		2061	174.1	280°.	1314	359.0
	2705	100.0		2198	162.7		1404	336.0
100°.	892	351.7		2357	151.3		1507	312.8
	936	334.5		2535	139.9		1626	289.5
	1002	311.3		2747	128.5		1765	266.4
	1081	288.2		2996	117.2		1928	243.5
	1171	265.2		3140	111.5		2124	220.4
	1275	242.3		3295	105.9		2301	203.1
	1402	219.4		3468	100.1		2509	186.0
	1516	202.2		3664	94.5		2670	174.6
	1647	185.2	200°.	1121	358.3		2850	163.2
	1749	173.8		1195	335.3		3056	151.8
	1862	162.4		1283	312.1		3296	140.4
	1993	151.1		1382	289.0		3578	128.9
	2141	139.7		1501	265.9		3917	117.6
	2316	128.4		1639	243.0		4104	111.9
	2519	117.0		1805	219.9		4321	106.2
	2638	111.3		1953	202.7		4555	100.4
	2763	105.7		2128	185.7		4815	94.8
	2902	100.0		2264	174.3			
	3058	94.3						

*Relation of Pressure to Temperature at Constant Volume.
Isochors.*

For the smaller volumes isobars were first constructed from the isothermals, and the temperatures at definite volumes were read from the isobars. The data from which the isobars were constructed are given below :—

Isobars read from Isothermals.

Temp....	130°.	140°.	150°.	160°.	170°.	180°.	190°.	200°.	210°.	220°.	230°.
Pressure in metres.	Volume in cub. cms.										
12	2·0066	2·0796	2·1692								
16	1·9958	2·0639	2·1464	2·2546							
20	1·9852	2·0500	2·1266	2·2240	2·3526	2·5600					
24	1·9755	2·0372	2·1094	2·1986	2·3115	2·4715	2·7700				
28	1·9661	2·0254	2·0935	2·1767	2·2780	2·4105	2·6145	3·0840			
32	1·9574	2·0144	2·0790	2·1574	2·2496	2·3650	2·5255	2·7915			
36	1·9486	2·0042	2·0656	2·1398	2·2247	2·3285	2·4635	2·6602	2·9910		
40	1·9406	1·9948	2·0532	2·1256	2·2026	2·2965	2·4160	2·5775	2·8100	3·1960	
44	1·9330	1·9861	2·0417	2·1087	2·1830	2·2695	2·3772	2·5135	2·7000	2·9660	
48	1·9257	1·9776	2·0307	2·0946	2·1652	2·2460	2·3438	2·4630	2·6180	2·8290	3·1180
52	1·9186	...	2·0204	2·0816	2·1487	2·2245	2·3150	2·4225	2·5575	2·7330	2·9590
56	2·0106	2·0691	2·1335	2·6570	2·8460

In the following tables the data for the isochors are given ; those for small volumes were read from the isobars, and those for larger volumes from the isotherms.

Isochors read from Isobars.

Volume.	2·0.	2·1.	2·2.	2·3.	2·4.	2·5.	2·6.	2·7.	2·8.	2·9.	3·0.
Pressure in metres.	Temperature.										
12	129·0	142·5									
16	130·7	144·7	155·35	163·45	169·6						
20	132·4	146·8	157·8	166·3	172·85	177·75					
24	134·15	148·8	160·1	169·1	176·0	181·3	185·35	188·4	190·6	192·1	193·1
28	136·0	150·8	162·5	171·85	179·25	185·05	189·45	192·55	195·0	197·25	198·9
32	137·7	152·9	165·0	174·65	182·4	188·65	193·5	197·4	200·15
36	139·4	154·9	167·2	177·5	185·75	192·05	197·4	201·5	204·95	207·8	210·2
40	141·0	156·8	169·8	180·4	188·85	195·7	201·25	205·85	209·7	212·75	215·6
44	142·9	158·8	172·05	183·05	191·8	199·05	205·1	210·0	214·3	217·9	220·9
48	144·55	160·95	174·65	185·9	195·0	202·6	208·9	214·25	218·8	222·75	226·3
52	146·3	162·95	176·8	188·3	198·0	206·0	212·75	218·3	223·2	227·7	231·5
56	...	164·95	222·4	227·75	232·4	...

Isochors read from Isothermals.

Volume.	2.9.	3.0.	3.2.	3.4.	3.6.	3.8.	4.0.	4.3.	4.6.	5.0.
Temp.	Pressure.									
190.....	22500									
200.....	29920	28720	27330	26760	26500	26360	26290	26200	26150	26090
210.....	37770	35950	33600	32260	31480	30960	30580	30140	29800	29410
220.....	45800	43210	39960	37930	36600	35660	34960	34120	33450	32720
230.....	53940	50810	46430	43730	41820	40420	39400	38150	37140	36000
240.....	53040	49870	47390	45450	44000	42250	40890	39370
250.....	52830	50470	48630	46400	44630	42720
260.....	53240	50550	48290	45940
270.....	54670	52050	49260
280.....	55800	52500

Isochors read from Isothermals.

Volume.	5.5.	6.	6.5.	7.	8.	9.	10.	12.	14.	16.
Temp.	Pressure.									
180.....	18600	17335	16130
190.....
200.....	25980	25760	25450	25140	24400	23540	22630	20840	19150	17690
210.....	28940	28460
220.....	31920	31090	30350	29630	28120	26730	25400	23000	20985	19200
230.....	34800	33750
240.....	37790	36400	35140	33940	3 750	29830	28110	2 150	22730	20680
250.....	40740	39000
260.....	43590	41510	39770	38140	3 300	32870	30790	27260	24460	22140
270.....	46400	44040
280.....	49330	46600	44270	42220	38740	35860	33390	29270	26110	23555

Isochors read from Isothermals.

Volume.	18.	20.	22.	26.	30.	35.	40.	50.	60.	70.	80.
Temp.	Pressure.										
100.....	3965	3532
120.....	6725	5640	4849	4249	3782
140.....	9880	8985	8025	7250	6055	5190	4535	4026
160.....	13640	12865	12115	10825	9735	8635	7772	6465	5515	4812	4263
180.....	15030	14060	13180	11695	10475
200.....	16370	15210	14215	12520	11180	9830	8775	7250	6150	5345	4726
220.....	17695	16370	15220	13330	11880
240.....	18980	17505	16250	14160	12570	11020	9800	8010	6805	5900	5208
260.....	20225	18610	17230	14980	13260
280.....	21465	19690	18200	15790	13975	12200	10825	8815	7462	6465	5699

Isochors read from Isothermals.

Volume.	90.	100.	120.	140.	160.	180.	200.	230.	260.	300.	350.
Temp.	Pressure.										
40.....	857
60.....	1485	1347	1182	1053	920
80.....	2705	2304	2001	1773	1589	1440	1260	1123	981
100.....	3187	2907	2464	2137	1889	1693	1532	1340	1193	1040	896
120.....	3404	3098	2620	2272	2005	1794	1622	1419	1262	1100	947
140.....	3613	3285
160.....	3832	3477	2931	2534	2233	1996	1804	1576	1400	1219	1048
200.....	4237	3832	3231	2791	2458	2196	1981	1729	1535	1334	1146
240.....	4653	4212	3536	3047	2679	2393	2157	1882	1669	1451	1246
280.....	5087	4588	3836	3305	2905	2592	2337	2038	1808	1571	1349

The values of b and a in the equation $p=bT-a$ were obtained graphically from the preceding data. As with isopentane, the deviations are exceedingly small at the largest and smallest volumes and about the critical volume, but are larger at intermediate volumes; they exhibit a similar regularity and are in the same direction as with isopentane. Here again the relation $p=bT-a$ at constant volume, if not absolutely true, may be taken as a very close approximation to the truth.

In studying the variation of b and a with the volume it was found convenient, in the case of isopentane, to plot the values of $\frac{10,000}{bv}$ and of $\frac{10^{10}}{av^2}$ against $v^{-\frac{1}{3}}$; and this has also been done for normal pentane. The values of b , a , $v^{-\frac{1}{3}}$, $\frac{10^4}{bv}$, and $\frac{10^{10}}{av^2}$ for a series of volumes are given in the table below and, for the sake of comparison, the corresponding values of $\frac{10^4}{bv}$ and $\frac{10^{10}}{av^2}$ for isopentane are added. (Table p. 362.)

The values of $10^{10}/av^2$ are plotted against $v^{-\frac{1}{3}}$ in the diagram on p. 363.

In a former paper by one of the authors (Phil. Mag. xlv. p. 77) it was pointed out that, besides the quantities b and τ , it is often useful to consider a fresh quantity τ , which is defined as follows:—For each volume there is one and only one temperature at which the gas has its pressure equal to that given by the laws of a perfect gas; this temperature is denoted by τ . It is also shown that the numerical value

Vol. in c.c.'s.	b.	a.	$v^{-\frac{1}{3}}$.	$10^4/bv.$		$10^{10}/av^2.$	
	From drawn isochors.			N. Pentane.	Iso- pentane.	N. Pentane.	Iso- pentane.
2.0	2312	917,550	.7937	2.163	2.165	2725	2783
2.1	1980	811,210	.7809	2.405	2.487	2795	2952
2.2	1668	698,520	.7689	2.725	2.764	2958	3053
2.3	1436	610,860	.7576	3.028	3.051	3095	3181
2.4	1265	544,000	.7468	3.294	3.365	3191	3329
2.5	1132	490,380	.7368	3.534	3.602	3263	3397
2.6	1010	438,880	.7272	3.808	3.851	3371	3480
2.7	940	409,900	.7181	3.940	4.056	3347	3522
2.8	858	373,910	.7095	4.162	4.279	3411	3586
2.9	790	343,580	.7013	4.365	4.520	3461	3670
3.0	730	316,470	.6931	4.566	4.731	3511	3728
3.2	642.6	276,720	.6786	4.863	4.986	3529	3708
3.4	572.7	244,270	.6650	5.136	5.281	3541	3736
3.6	523.8	221,500	.6526	5.303	5.455	3484	3682
3.8	478.6	200,200	.6408	5.499	5.507	3459	3632
4.0	448.6	186,100	.6300	5.573	5.733	3358	3553
4.3	407.3	166,640	.6150	5.710	5.859	3245	3426
4.6	371.2	149,540	.6013	5.856	5.973	3160	3313
5.0	331.1	130,570	.5848	6.040	6.114	3069	3184
5.5	292.7	112,470	.5665	6.212	6.298	2930	3062
6.0	260.4	97,320	.5503	6.400	6.489	2855	2976
6.5	234.7	85,350	.5358	6.555	6.628	2773	2881
7	212.6	75,210	.5227	6.720	6.786	2713	2816
8	179.5	60,377	.5000	6.964	7.046	2588	2697
9	153.9	49,178	.4805	7.220	7.294	2510	2615
10	134.5	40,923	.4642	7.435	7.541	2444	2564
12	107.5	30,043	.4368	7.752	7.917	2312	2466
14	88.35	22,639	.4149	8.085	8.258	2254	2405
16	74.15	17,388	.3968	8.429	8.463	2247	2327
18	65.15	14,478	.3816	8.524	8.698	2132	2288
20	56.90	11,721	.3684	8.787	8.872	2133	2242
22	51.00	9,938	.3569	8.913	8.979	2079	2172
26	41.50	7,125	.3375	9.268	9.314	2076	2160
30	35.35	5,570	.3218	9.430	9.470	1995	2079
35	29.78	4,261	.3057	9.594	...	1916	...
40	25.47	3,263	.2924	9.815	9.813	1915	1969
50	19.73	2,089	.2714	10.14	10.26	1915	2067
60	16.23	1,521	.2554	10.27	10.46	1826	2046
70	13.75	1,143	.2426	10.39	10.53	1785	1957
80	11.91	894	.2321	10.50	10.49	1748	1788
90	10.45	694	.2231	10.63	10.61	1779	1782
100	9.325	563	.2154	10.72	10.74	1775	1845
120	7.653	388	.2027	10.89	10.87	1790	1823
140	6.520	296	.1926	10.96	10.92	1720	1747
160	5.677	230	.1842	11.01	11.07	1700	1860
180	5.030	187	.1771	11.04	11.18	1650	1930
200	4.478	138	.1710	11.17	11.24	1810	1950
230	3.892	113	.1632	11.15	11.18	1670	1730
260	3.418	81.5	.1567	11.25	11.22	1810	1700
300	2.953	62.0	.1496	11.29	11.27	1790	1680
350	2.513	40.0	.1419	11.37	11.33	2040	1770

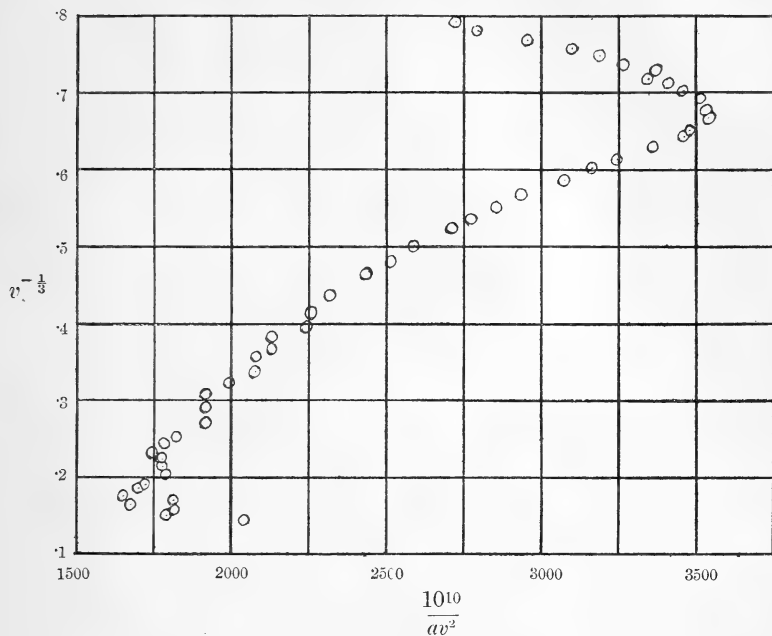

of τ is given by the expression $\frac{a}{b - R/v}$; making use of the values of a and b already given for normal pentane, the values of τ have been calculated, and the results are given in the following Table:—

v .	τ .	v .	τ .	v .	τ .
2.0	488.0	4.6	814.9	35	833.9
2.1	517.1	5.0	824.3	40	841.0
2.2	547.6	5.5	828.8	50	848.0
2.3	576.0	6.0	835.4	60	826.6
2.4	601.0	6.5	838.4	70	810.6
2.5	623.4	7	843.2	80	798.2
2.6	647.4	8	843.3	90	813.6
2.7	660.9	9	848.9	100	817.1
2.8	680.3	10	850.1	120	845.3
2.9	698.0	12	844.9	140	843.3
3.0	715.8	14	849.2	160	821.4
3.2	742.3	16	861.6	180	806.0
3.4	766.5	18	843.2	200	862.5
3.6	780.2	20	854.3	230	824.8
3.8	796.7	22	845.8	260	840.2
4.0	799.7	26	859.5	300	826.7
4.3	807.0	30	849.1	350	869.6

An examination of this table shows that τ remains fairly constant for all large volumes down to about vol. 8. The actual numbers obtained vary a good deal; but these variations are sometimes in one direction and sometimes in another, and there is no steady increase or decrease. It appears, then, that all the values of τ above vol. 8 could be treated as the same without introducing any serious error; this occurred likewise in the case of isopentane. What is still more noteworthy is that the same constant value of τ could be used for both normal pentane and isopentane, keeping within the limits of experimental error. The mean value of τ for all volumes above 8 was found to be 842.4 for isopentane; it is 838.5 for normal pentane; and the intermediate value 840 could be used in both cases without introducing any error greater than the unavoidable errors of experiment.

When we pass on to the neighbourhood of the critical point, the value of τ diminishes steadily as the volume decreases. For the critical volume itself τ is about 807, and for vol. 2 it has sunk to 488.

The most important conclusion arrived at in the case of isopentane was that the molecular pressure a does not follow a continuous law, but passes abruptly from one law to another somewhere about vol. 3.4 (Phil. Mag. xlv. p. 79). This inference was based on the study of a diagram in which

the quantity $\frac{1}{av^2}$ was plotted against $v^{-\frac{1}{2}}$, and there appeared to be considerable evidence of discontinuity in the neighbourhood of the volume already mentioned. Of course it is impossible to *prove* discontinuity of slope by means of a series of isolated points, but it is suggested very strongly; and even if there be not discontinuity in the true mathematical sense of the term, there seems to be such a rapid change of behaviour as to amount practically to the same thing.

It was therefore a matter of some interest to discover whether the diagram obtained by plotting $\frac{1}{av^2}$ against $v^{-\frac{1}{2}}$ in the case of normal pentane would exhibit the same peculiarity. The diagram is given on p. 363, and it is easily seen that we have here a similar suggestion of discontinuity in the slope of $\frac{1}{av^2}$; this occurs somewhere about vol. 3.4, as with isopentane.

In attempting to find a formula for the pressure of normal pentane we are therefore confronted with the possibility that we may require two distinct algebraic equations. We may simplify the problem considerably by confining our attention

to volumes lying above 3.4; and this limitation still leaves us with all those conditions of the substance in which we can most usefully compare it with isopentane.

Looking at the table on p. 362, which gives the series of values of $\frac{1}{av^2}$, and comparing it with the similar table for isopentane (Proc. Phys. Soc. xiii. pp. 654, 655), we notice that at the same volume the value of $\frac{1}{av^2}$ is always smaller in the former case than in the latter. The difference is not great, but it remains too persistently with the same sign for us to disregard it. As we proceed to larger and larger volumes, however, the difference diminishes on the whole, and an interesting question arises whether we should be justified in treating it as ultimately vanishing when v is made infinite.

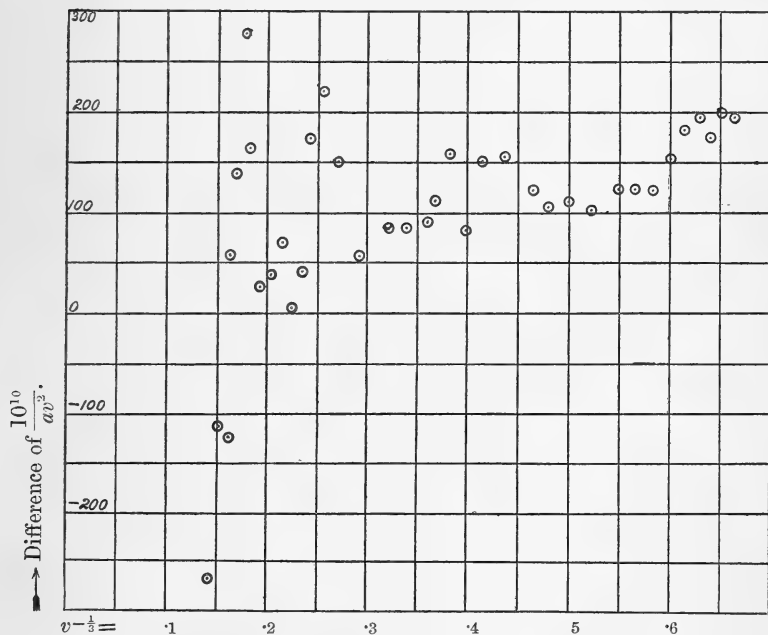

To elucidate this point a diagram was drawn in which the differences of $\frac{1}{av^2}$ between isopentane and normal pentane were plotted against $v^{-\frac{1}{3}}$; this diagram is reproduced above. The diminution in the differences with increase of volume is well shown in spite of the "wobbling" at large
Phil. Mag. S. 5. Vol. 47. No. 287. April 1899. 2 C

volumes; and a line running through the points might apparently end at zero difference. But though this result might be accepted as consistent with the experimental evidence if there were independent grounds for believing in it, it cannot be considered as the most probable judging solely from the diagram; we should be rather led to believe that even at infinite volumes the value of $\frac{1}{av^2}$ for isopentane remained larger than that for normal pentane.

The above results respecting α and τ are chiefly interesting because they seem capable of throwing some light on the vexed question of the influence exerted by difference of chemical structure on the thermal properties of a substance. Concerning this matter very little is known at present; but it is common knowledge among organic chemists that two substances may have the same chemical composition and show practically the same behaviour whilst in the condition of rare vapour, and yet they may differ considerably as to their thermal properties in the liquid state. The great field of observation in which the substances lie between the conditions of a rare vapour and a common liquid has been left almost entirely unexplored. This gap in our knowledge makes it impossible to say in what precise manner the difference between two isomeric substances originates; whether it arises conjointly with the first deviations from Boyle's law, or whether the difference remains inappreciable even with increasing density until we reach the neighbourhood of the critical point. We may put the problem more precisely as follows:—If we imagine the pressure given by a series of ascending powers of the density, what is the lowest power of the density which has different coefficients for two isomeric substances?

We are now able to answer this question with a fair amount of exactness in the case of the two isomers, normal pentane and isopentane. If, as seems most probable, there is a difference between the $\frac{1}{av^2}$ for normal pentane and the $\frac{1}{av^2}$ for isopentane, even at infinitely large volumes, this shows that the coefficients of the second power of the density in the expansion of p must be different for the two substances. On the other hand, if there is no difference between the $\frac{1}{av^2}$ for normal pentane and the $\frac{1}{av^2}$ for isopentane at infinitely large volumes, then the coefficients of the second power of the density in the expansion for p must be the same, since τ has

already been shown to have the same value for the two substances at infinite volumes; and the lowest power of the density which has different coefficients for the two isomers must be the third.

It was thought advisable to test these conclusions by a different method. In a former paper by one of the authors (Phil. Mag. xliv. p. 80; see also Phil. Mag. xlv. p. 105) it was shown that in the case of isopentane we might reproduce the original observations very closely by putting

$$p = \frac{RT}{v} \left\{ 1 + \frac{e}{v+k-gv^{-2}} \right\} - \frac{l}{v(v+k)},$$

where R , e , k , g , and l are constants. If we assume that this formula holds also for normal pentane, and if it be true that the difference of pressure between normal pentane and isopentane at the same temperature and volume varies ultimately as the third power of the density, then we should be able to reproduce the experimental data for normal pentane by means of the above formula, giving to R , e , and l the values already found for isopentane. We may accordingly take $R=863.56$, $e=7.473$, $l=5420800$, and we still have the constants k and g left at our disposal to meet the requirements of the normal pentane data. On examining the observations given in Series I. of this paper we find that we can conveniently put $k=3.135$, $g=6.695$, and we have to test how far the formula with these constants reproduces the experimental results given in Series II., III., and IV. In order to institute an effective comparison between theory and observation a diagram was made in which pv was plotted against $v^{-\frac{1}{3}}$; the calculated isothermals were drawn as continuous lines, while the experimental values were put in as dots. An examination of the diagram shows that a fair concordance between calculation and experiment has been secured; but the agreement is not so good as could be wished. Deviations amounting to 1 per cent. are not uncommon, and in places they approach 2 per cent. If we have regard to the differences which often occur in inquiries of this kind between the results of independent observers, we might conclude that the above deviations are unimportant, and that R , e , and l were really the same for the two pentanes as supposed. But it seems more likely that the deviations are too large to be neglected; hence, the most probable inference is that the l for normal pentane is not the same as the l for isopentane, thereby confirming our former conclusion.

XXXII. *An Application of the Diffraction-Grating to Colour-Photography.* By R. W. WOOD*.

IF a diffraction-grating of moderate dispersion and a lens be placed in the path of a beam of light coming from a linear source, and the eye be placed in any one of the spectra formed to the right and left of the central image, the entire surface of the grating will appear illuminated with light of a colour depending on the part of the spectrum in which the eye is placed. If one part of the grating has a different spacing from the rest, the spectrum formed by this part will be displaced relatively to the first; and if the eye be placed in the overlapping part of the two spectra, the corresponding portions of the grating will appear illuminated in different colours. This principle I have made use of in the development of a new method for producing photographs in natural colour. I have eliminated the use of pigments and coloured screens entirely in the finished picture, the photograph being nothing more nor less than a diffraction-grating of variable spacing, the width between the lines in the different parts of the picture being such as to cause them to appear illuminated in their proper colours when viewed in the manner described.

We will take at the start three diffraction-gratings of such spacing that the deviation of the red of the first is the same as that of the green of the second and the blue of the third (the red, green, and blue in question being of the tints of the primary colours of the Young-Helmholtz theory of colour-vision). If these three gratings be mounted side by side in front of a lens their spectra will overlap; and an eye placed in the proper position will see the first grating red, the second green, and the third blue. If the first and second be made to overlap, this portion will send both red and green light to the eye, and will in consequence appear yellow. If all three be made to overlap in any place, this place will send red, green, and blue light to the eye, and will appear white.

The method that I first employed to produce photographs showing natural colours on this principle is the following. — Three negatives were taken through red, green, and blue screens in the usual manner: from these, positives were made on ordinary lantern-slides (albumen-slides are necessary for reasons which I will speak of presently). The positives, when dry, were flowed with bichromated gelatine and dried in subdued light. The three diffraction-gratings of proper spacing, ruled or photographed on glass, were placed over these positives, and exposed to the sun or electric light for

* Communicated by the Author.

thirty seconds. On washing these plates in warm water, diffraction-gratings of great brilliancy were formed directly on the surface of the film. Albumen-plates must be used, since the warm water softens and dissolves a gelatine film. Three sheets of thin glass, sensitized with the bichromated gelatine, were placed under the three positives, and prints taken from them. The portions of each plate on which the light had acted bore the impression of the corresponding diffraction-grating, strongly or feebly impressed, according to the density of the different parts of the positives. These three plates, when superimposed and placed in front of a lens and illuminated by a narrow source of light, appear as a correctly coloured picture, when viewed with the eye placed in the proper position. Perfect registration of the different parts of the picture could not be obtained in this way, for obvious reasons. I worked for awhile with the thin glass from which covers for microscopical slides are made. This gave much better results, but was too fragile for practical purposes. It then occurred to me that if I could get the entire grating system on a single film, not only would the difficulty about perfect registration vanish, but the pictures could be reproduced by simple contact-printing on chrom-gelatine plates as easily as blue prints are made. I was surprised to find that successive exposures of the same plate under the positives, perfect registration being secured by marks on the plates, produced the desired result. On washing this plate in warm water and drying, it becomes the finished coloured photograph. Where the reds occur in the original, the spacing of the first grating is present; where the yellows occur the spacings of both the first and second are to be found superimposed; where the blues occur are the lines of the third grating; while in the white parts of the picture all three spacings are present. It seems almost incredible that, by exposing the plate in succession under two gratings the spacings, of both should be impressed—superimposed—in such a manner as to give the colours of each in equal intensity; but such is the fact. Thus far I have had at my disposal but two gratings of only approximately the right spacing, one giving the red, the other the green: with these I have photographed stained-glass windows, birds, and butterflies, and other still-life objects, the finished pictures showing reds, yellows, and greens in a most beautiful manner. By making a separate plate from the blue positive, using the same spacing as with the green, and setting this plate behind the other at an angle, I have obtained the blues and whites, the grating-space being diminished by foreshortening, though, of course, perfect regis-

tration of the different portions of the picture could not be obtained.

One of the great advantages of this method is the facility with which duplicates can be made. If we place the finished picture in a printing-frame over a glass plate coated with bichromated gelatine, and expose it to sunlight, on washing the plate in warm water we obtain, by a single printing process, a second colour-photograph, equal to the first in every respect, and also positive. From this second copy we can print others, all being positive.

The apparatus for viewing the pictures consists of a cheap double-convex lens mounted on a little frame, as shown in fig. 1, with a perforated screen for bringing the eye into the

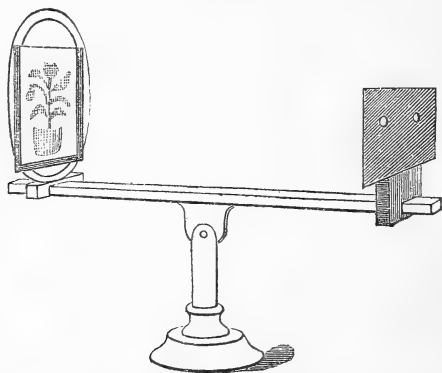

right position. I find that, by using a lens of proper focus, it is possible to so adjust the apparatus that the picture can be seen in its natural colours with both eyes simultaneously, since corresponding overlapping spectra are formed on each side of the central direct image. A gas-flame turned edge-wise, or the filament of an incandescent light, makes a convenient source of light. The colours are of great brilliancy and purity, almost too brilliant in fact, though dark reds and ochres are reproduced with considerable fidelity. The pictures can be projected by employing a powerful arc-light, placing a rather wide slit in the overlapping spectra, and mounting the projecting lens beyond this. The pictures that I have obtained thus far measure 2.5 in. by 2.5 in., and have been thrown up about 3 feet square. The fact that only a small percentage of the light is utilized makes great amplification difficult. Certain experiments that I have made lead me to believe that the process can be greatly simplified.

I have exposed an ordinary photographic plate in a camera

under a diffraction-grating placed in front of, and in contact with, the film. On development, we obtain a negative the dark portions of which are broken up into fine lines, corresponding to the lines of the grating; and on viewing this in the apparatus just described, the blue components of the picture are seen, though not so brilliant as with the transparent gelatine plate owing to the coarseness of the grain.

I believe that by the use of a suitable photographic plate to be exposed in succession in the camera, under red, green, and blue screens, on the surfaces of which suitable diffraction-gratings have been photographed, it will be possible to obtain the colour-photograph directly. The screens can be swung into position in succession by a suitable mechanical arrangement operated outside of the camera. The plate, on development, will be a negative in the ordinary sense of the term, though when seen in the viewing-apparatus it will appear as a coloured positive, since on the transparent portions which correspond to black in the original, no grating-lines have been impressed: consequently these portions will appear dark. The dark portions, however, where the lines are impressed will light up in their appropriate colours. From this plate as many copies as are desired can be made by contact-printing on bichromated gelatine.

Of course it is a question whether superimposed gratings can be impressed on a plate in this manner. Judging from the experiments I have made, I imagine that the gratings on the colour-screens would have to be made with the opaque portions broad in proportion to the transparent.

I have overcome the difficulty of obtaining large diffraction-gratings by building up photographic copies in the following manner. The original grating ruled on glass was mounted against a rectangular aperture in a vertical screen, the lines of the grating being horizontal. Immediately below this was placed a long piece of heavy plate-glass, supported on a slab of slate to avoid possible flexure. A strip of glass, a little wider than the grating, sensitized with bichromated gelatine was placed in contact with the lines of the grating, and held in position by a brass spring. The lower edge of the strip rested upon the glass plate so that it could be advanced parallel to the lines of the grating, and successive impressions taken by means of light coming through the rectangular aperture. In this way I secured a long narrow grating; and by mounting this against a vertical rectangular aperture, and advancing a second sensitized plate across it in precisely the same manner, I obtained a square grating of twenty-five times the area of the original. It was in this manner that I prepared the

grating used to print the impressions on the three positives. So well did they perform, that it seemed as if it might be possible in this way to build up satisfactory gratings of large size for spectroscopic work. Starting with a 1-inch grating of 2000 lines, I have built up a grating 8 inches square, which, when placed over the object-glass of a telescope, showed the dark bands in the spectrum of Sirius with great distinctness. No especial precautions, other than the use of the flat glass plate, were taken to insure absolute parallelism of the lines, and I have not had time to thoroughly test the grating. The spectra, however, are of extraordinary brilliancy; and on the whole the field seems promising. This matter will, however, be deferred to a subsequent paper.

Physical Laboratory of the
University of Wisconsin, Madison.

XXXIII. *Denudation and Deposition.*

By G. JOHNSTONE STONEY, M.A., D.Sc., F.R.S.*

IN a lecture to the Royal Geographical Society, of which a copious extract is given in 'Nature' of the 2nd of February, 1899, Dr. J. W. Gregory discusses many of the causes which may have led to the existing form of the earth. But there is one important factor in the problem left unnoticed, namely, the conspicuous alterations of level which may be attributed to the earth's compressibility, and which seem to have been brought about wherever either denudation or deposition have continued over wide areas and for a long time.

Dr. Gregory makes a convenient division of the earth into three parts:—(1) the unknown internal centrosphere; (2) the rocky crust or lithosphere; (3) the oceanic layer, or hydrosphere. These, with the atmosphere, which may be added as a fourth part, make up the whole earth.

If now we imagine a pyramid whose base is a square centimetre of the surface of the solid part of the earth and whose vertex is the earth's centre, it has a volume of about 212 cubic metres, which is the same as 212 millions of cubic centimetres. This pyramid passes first through the lithospheric shell, or outer crust, and then halfway across the centrosphere to the centre of the earth. All the materials of which it consists are compressible. Those which lie within the outer shell consist mainly of carbonates, silicates, and aluminates, and have probably a coefficient of compressibility about equal to that of glass; while the compressibility of the centrosphere is unknown, and may be either more or less. The observed form of the earth's surface seems to suggest that the average

* Communicated by the Author.

compressibility of the lithosphere and centrosphere taken together is not far from that of the more incompressible kinds of glass. Glass of this description yields to compression about $2\frac{1}{2}$ times more than solid cast iron, but less than mercury (which seems to be the only liquid metal that has been experimented on) in the ratio of 2 to 3. It is about 20 times more incompressible than water.

We shall then, as a provisional hypothesis, assume that the earth has the same compressibility as the more resistant kinds of glass, which lose about $2\frac{1}{2}$ billionths of their volume for each pressure of a dyne per square centimetre over their surface. Combining this with the volume of the earth-pyramid given above, we find that our hypothesis leads to the conclusion that if the sides of the pyramid were kept from yielding, and if the weight of a cubic centimetre of water were placed on its outer end, this would reduce its bulk by half a cubic centimetre. A cubic centimetre of stone, of specific gravity 3, would accordingly depress its outer end by $1\frac{1}{2}$ centimetres. It follows from this that if meteors rained upon the earth (supposed to be without an ocean) producing a deposit over its whole surface a centimetre thick, and of material as dense as stone, the result would be that the earth after this accession would be smaller; its surface would sink down about half a centimetre. Correspondingly, if by any agency a centimetre of the earth's crust could be removed over the whole earth, the earth's surface would stand $\frac{1}{2}$ a centimetre higher than before. These are the effects which deposition and denudation would respectively produce if they could operate over the whole earth. And, if they operate over any extensive area of the earth's surface, they will produce effects of the same kind, complicated a little by the displacement of the earth's centre of attraction, or rather locus of centres of attraction.

This may be well seen in the oldest parts of the oldest continents—parts of Asia and Africa—to whose present elevation denudation*, operating over an extensive area and for long ages, has probably chiefly contributed. And, correspondingly, there is a deepening of those parts of the ocean where the deposition of sufficiently heavy† material has been going on over a great area for an immense time.

* Underground waters produce the same dynamical effect as surface denudation, by reason of the materials they remove in solution.

† Where the sub-aqueous deposit is spread over only a small part of the surface of the globe (which is the only case we need consider), the compression is due, not to the whole weight of the deposit, but only to its excess over the weight of an equal bulk of water. Hence to produce an equivalent effect the material must be denser than it would need to be if the deposition had been on land.

The *extent* of the area is an essential condition, *i. e.*; the *lateral* dimensions of the inverted pyramid which has the area for its base and the centre of the earth for its vertex. If the area is small or narrow, oblique forces exerted by the parts surrounding this pyramid come more into play. They enable the part within the pyramid to act like a bridge; and the support thus given enables denudation, if limited to a small area, to scoop out valleys, and deposition to produce ridges, as may be seen in the glaciers and moraines of mountainous countries. On the other hand, if the erosion due to glacial action takes effect over a great stretch of country, as it does in Greenland, and as it formerly did in Ireland, it causes the surface to rise.

A nearly even balance between the two opposite tendencies may be seen in Egypt, where borings exhibit fluviatile deposits at great depths below the present surface, although the surface is only about as much raised above the sea now as it was when those ancient deposits were laid down by the Nile. Each year's deposit makes the surface go down, but only about as much as its own thickness, so that the new surface each year is not far from being at the same level as that of the preceding year. If the deposit had taken place over a much greater breadth of country, the whole would have gone down. It would have become a ridge if it had been confined to a much narrower strip and if the river could have been kept from diverging.

A similarly instructive case is that of Brazil, where an immense plateau is continuously being denuded by the vast rivers that drain it. But here there is also an equally uninterrupted addition to the solid materials of the earth by the luxuriant tropical vegetation which everywhere prevails; and it is probably because the accessions and withdrawals are nearly equal to one another, that the level of the surface has been but little changed.

Denudation may cause the surface to rise within a space which is in a considerable degree more circumscribed than the areas of elevation hitherto considered, if the conditions are such that the stresses that come into existence round the boundary of this limited space can produce faults, and prevent the material which is outside the pyramid from being in a position to help to keep down the material which is within. This seems to have happened in the case of that vast mass of mountains—the Himalayas, the Hindu Kush, and their associated ranges—where excessive denudation accompanied by the isolation secured by faults has occasioned a proportionately great elevation above what was probably a humble beginning;

where the deposits in the Bay of Bengal are probably the cause of its great depth; and where earthquakes in the intervening regions betray when the faults are establishing themselves which render the rising and the descending areas independent of one another, and allow the denudation on the one side and the deposition on the other to produce each its full effect, without mutual interference.

Of course all compressions and dilatations must be accompanied by other movements within the earth, and at all depths; which may be slow but are no less sure. In fact, there is no material which can resist yielding to differences of pressure, however feeble, if they act for a long time and over a large surface; and such pressures, urging in various directions, must arise both from the compressions and dilatations spoken of above, and from other causes, among which movements of heat and the heterogeneous character of the materials of which the earth consists are prominent. The earth, therefore, is in a state of never-ending change, which to become conspicuous to man would only need to be placed in some kind of kinematograph arrangement which would hurry over millions of years in fractions of a second. These effects mix with and complicate those which have been taken account of in the present paper.

It is interesting to note how the agencies we have been considering would operate upon other bodies of the universe. Events equivalent to denudation and deposition which cause excessively slow movements in our small earth, would act with increased promptness upon such great planets as Jupiter, Saturn, Uranus, and Neptune, and with violence upon bodies that attain the size of the sun and stars. On the other hand, on bodies with the dimensions of the moon they are relatively feeble, and must be very slow in producing any appreciable effect.

XXXIV. *On the Transmission of Light through an Atmosphere containing Small Particles in Suspension, and on the Origin of the Blue of the Sky.* By LORD RAYLEIGH, F.R.S.*

THIS subject has been treated in papers published many years ago †. I resume it in order to examine more closely than hitherto the attenuation undergone by the primary light on its passage through a medium containing small particles, as dependent upon the number and size of the particles. Closely connected with this is the interesting

* Communicated by the Author.

† Phil. Mag. xli. pp. 107, 274, 447 (1871); xii. p. 81 (1881).

question whether the light from the sky can be explained by diffraction from the molecules of air themselves, or whether it is necessary to appeal to suspended particles composed of foreign matter, solid or liquid. It will appear, I think, that even in the absence of foreign particles we should still have a blue sky*.

The calculations of the present paper are not needed in order to explain the general character of the effects produced. In the earliest of those above referred to I illustrated by curves the gradual reddening of the transmitted light by

* My attention was specially directed to this question a long while ago by Maxwell in a letter which I may be pardoned for reproducing here. Under date Aug. 28, 1873, he wrote:—

“I have left your papers on the light of the sky, &c. at Cambridge, and it would take me, even if I had them, some time to get them assimilated sufficiently to answer the following question, which I think will involve less expense to the energy of the race if you stick the data into your formula and send me the result. . . .

“Suppose that there are N spheres of density ρ and diameter s in unit of volume of the medium. Find the index of refraction of the compound medium and the coefficient of extinction of light passing through it.

“The object of the enquiry is, of course, to obtain data about the size of the molecules of air. Perhaps it may lead also to data involving the density of the æther. The following quantities are known, being combinations of the three unknowns,

M = mass of molecule of hydrogen ;

N = number of molecules of any gas in a cubic centimetre at 6° C. and 760 B.

s = diameter of molecule in any gas:—

Known Combinations.

MN = density.

Ms^2 from diffusion or viscosity.

Conjectural Combination.

$\frac{6M}{\pi s^3}$ = density of molecule.

“If you can give us (i.) the quantity of light scattered in a given direction by a stratum of a certain density and thickness; (ii.) the quantity cut out of the direct ray; and (iii.) the effect of the molecules on the index of refraction, which I think ought to come out easily, we might get a little more information about these little bodies.

“You will see by ‘Nature,’ Aug. 14, 1873, that I make the diameter of molecules about $\frac{1}{10000}$ of a wave-length.

“The enquiry into scattering must begin by accounting for the great observed transparency of air. I suppose we have no numerical data about its absorption.

“But the index of refraction can be numerically determined, though the observation is of a delicate kind, and a comparison of the result with the dynamical theory may lead to some new information.”

Subsequently he wrote, “Your letter of Nov. 17 quite accounts for the observed transparency of any gas.” So far as I remember, my argument was of a general character only.

which we see the sun a little before sunset. The same reasoning proved, of course, that the spectrum of even a vertical sun is modified by the atmosphere in the direction of favouring the waves of greater length.

For such a purpose as the present it makes little difference whether we speak in terms of the electromagnetic theory or of the elastic solid theory of light; but to facilitate comparison with former papers on the light from the sky, it will be convenient to follow the latter course. The small particle of volume T is supposed to be small in all its dimensions in comparison with the wave-length (λ), and to be of optical density D' differing from that (D) of the surrounding medium. Then, if the incident vibration be taken as unity, the expression for the vibration scattered from the particle in a direction making an angle θ with that of *primary vibration* is

$$\frac{D' - D}{D} \frac{\pi T}{r \lambda^2} \sin \theta \cos \frac{2\pi}{\lambda} (bt - r)^*, \quad \dots \quad (1)$$

r being the distance from T of any point along the secondary ray.

In order to find the whole emission of energy from T we have to integrate the square of (1) over the surface of a sphere of radius r . The element of area being $2\pi r^2 \sin \theta d\theta$, we have

$$\int_0^\pi \frac{\sin^2 \theta}{r^2} 2\pi r^2 \sin \theta d\theta = 4\pi \int_0^{\frac{1}{2}\pi} \sin^3 \theta d\theta = \frac{8\pi}{3};$$

so that the energy emitted from T is represented by

$$\frac{8\pi^3}{3} \frac{(D' - D)^2 T^2}{D^2 \lambda^4}, \quad \dots \quad (2)$$

on such a scale that the energy of the primary wave is unity per unit of wave-front area.

The above relates to a single particle. If there be n similar particles per unit volume, the energy emitted from a stratum of thickness dx and of unit area is found from (2) by introduction of the factor $n dx$. Since there is no waste of energy on the whole, this represents the loss of energy in the primary wave. Accordingly, if E be the energy of the primary wave,

$$\frac{1}{E} \frac{dE}{dx} = - \frac{8\pi^3 n}{3} \frac{(D' - D)^2 T^2}{D^2 \lambda^4}; \quad \dots \quad (3)$$

whence

$$E = E_0 e^{-hx}, \quad \dots \quad (4)$$

where

$$h = \frac{8\pi^3 n}{3} \frac{(D' - D)^2 T^2}{D^2 \lambda^4}. \quad \dots \quad (5)$$

* The factor π was inadvertently omitted in the original memoir.

If we had a sufficiently complete expression for the scattered light, we might investigate (5) somewhat more directly by considering the resultant of the primary vibration and of the secondary vibrations which travel in the same direction. If, however, we apply this process to (1), we find that it fails to lead us to (5), though it furnishes another result of interest. The combination of the secondary waves which travel in the direction in question have this peculiarity, that the phases are no more distributed at random. The intensity of the secondary light is no longer to be arrived at by addition of individual intensities, but must be calculated with consideration of the particular phases involved. If we consider a number of particles which all lie upon a primary ray, we see that the phases of the secondary vibrations which issue along this line are all the same.

The actual calculation follows a similar course to that by which Huygens' conception of the resolution of a wave into components corresponding to the various parts of the wave-front is usually verified. Consider the particles which occupy a thin stratum dx perpendicular to the primary ray x . Let AP (fig. 1) be this stratum and O the point where the vibration is to be estimated. If $AP = \rho$, the element of volume is $dx \cdot 2\pi\rho d\rho$, and the number of particles to be found in it is deduced by introduction of the factor n . Moreover, if $OP = r$, $AO = x$, $r^2 = x^2 + \rho^2$, and $\rho d\rho = r dr$. The resultant at O of all the secondary vibrations which issue from the stratum dx is by (1), with $\sin \theta$ equal to unity,

Fig 1.

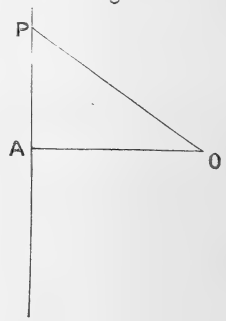

$$n dx \cdot \int_x^\infty \frac{D' - D}{D} \frac{\pi \Gamma}{r \lambda^2} \cos \frac{2\pi}{\lambda} (bt - r) 2\pi r dr,$$

or
$$n dx \cdot \frac{D' - D}{D} \frac{\pi \Gamma}{\lambda} \sin \frac{2\pi}{\lambda} (bt - x). \quad . . . \quad (6)$$

To this is to be added the expression for the primary wave itself, supposed to advance undisturbed, viz., $\cos \frac{2\pi}{\lambda} (bt - x)$, and the resultant will then represent the whole actual disturbance at O as modified by the particles in the stratum dx .

It appears, therefore, that to the order of approximation afforded by (1) the effect of the particles in dx is to modify the phase, *but not the intensity*, of the light which passes

them. If this be represented by

$$\cos \frac{2\pi}{\lambda} (bt - x - \delta), \quad \dots \quad (7)$$

δ is the *retardation* due to the particles, and we have

$$\delta = nT dx (D' - D) / 2D. \quad \dots \quad (8)$$

If μ be the refractive index of the medium as modified by the particles, that of the original medium being taken as unity, $\delta = (\mu - 1)dx$, and

$$\mu - 1 = nT (D' - D) / 2D. \quad \dots \quad (9)$$

If μ' denote the refractive index of the material composing the particles regarded as continuous, $D'/D = \mu'^2$, and

$$\mu - 1 = \frac{1}{2}nT(\mu'^2 - 1), \quad \dots \quad (10)$$

reducing to

$$\mu - 1 = nT(\mu' - 1) \quad \dots \quad (11)$$

in the case where $\mu' - 1$ can be regarded as small.

It is only in the latter case that the formulæ of the elastic-solid theory are applicable to light. In the electric theory, to be preferred on every ground except that of easy intelligibility, the results are more complicated in that when $(\mu' - 1)$ is not small, the scattered ray depends upon the shape and not merely upon the volume of the small obstacle. In the case of *spheres* we are to replace $(D' - D)/D$ by $3(K' - K)/(K' + 2K)$, where K, K' are the dielectric constants proper to the medium and to the obstacle respectively*; so that instead of (10)

$$\mu - 1 = \frac{3nT}{2} \frac{\mu'^2 - 1}{\mu'^2 + 2} \quad \dots \quad (12)$$

On the same suppositions (5) is replaced by

$$h = 24\pi^3 n \frac{(\mu'^2 - 1)^2 T^2}{(\mu'^2 + 2)^2 \lambda^4} \quad \dots \quad (13)$$

On either theory

$$h = \frac{32\pi^3 (\mu - 1)^2}{3n\lambda^4}, \quad \dots \quad (14)$$

a formula giving the coefficient of transmission in terms of the refraction, and of the *number of particles per unit volume*.

We have seen that when we attempt to find directly from (1) the effect of the particles upon the transmitted primary wave, we succeed only so far as regards the retardation. In

* Phil. Mag. xii. p. 98 (1881). For the corresponding theory in the case of an *ellipsoidal* obstacle, see Phil. Mag. vol. xlv. p. 48 (1897).

order to determine the attenuation by this process it would be necessary to supplement (1) by a term involving

$$\sin 2\pi(bt-r)/\lambda;$$

but this is of higher order of smallness. We could, however, reverse the process and determine the small term in question *à posteriori* by means of the value of the attenuation obtained indirectly from (1), at least as far as concerns the secondary light emitted in the direction of the primary ray.

The theory of these effects may be illustrated by a completely worked out case, such as that of a small rigid and fixed spherical obstacle (radius c) upon which plane waves of sound impinge*. It would take too much space to give full details here, but a few indications may be of use to a reader desirous of pursuing the matter further.

The expressions for the terms of orders 0 and 1 in spherical harmonics of the velocity-potential of the secondary disturbance are given in equations (16), (17), § 334. With introduction of approximate values of γ_0 and γ_1 , viz.

$$\gamma_0 + kc = \frac{1}{3}k^3c^3, \quad \gamma_1 + kc = \frac{1}{2}\pi + \frac{1}{6}k^3c^3,$$

we get

$$[\psi_0] + [\psi_1] = -\frac{k^2c^3}{3r} \left(1 + \frac{3\mu}{2}\right) \cos k(at-r) + \frac{k^5c^6}{9r} \left(1 - \frac{3\mu}{4}\right) \sin k(at-r), \quad \dots \quad (15)$$

in which c is the radius of the sphere, and $k = 2\pi/\lambda$. This corresponds to the primary wave

$$[\phi] = \cos k(at+x), \quad \dots \quad (16)$$

and includes the most important terms from all sources in the multipliers of $\cos k(at-r)$, $\sin k(at-r)$. Along the course of the primary ray ($\mu = -1$) it reduces to

$$[\psi_0] + [\psi_1] = \frac{k^2c^3}{6r} \cos k(at-r) + \frac{7k^5c^6}{36r} \sin k(at-r). \quad \dots \quad (17)$$

We have now to calculate by the method of Fresnel's zones the effect of a distribution of n spheres per unit volume. We find, corresponding to (6), for the effect of a layer of thickness dx ,

$$2\pi n dx \left\{ \frac{1}{6}k^3c^3 \sin k(at+x) - \frac{7}{36}k^4c^6 \cos k(at+x) \right\}. \quad \dots \quad (18)$$

To this is to be added the expression (16) for the primary wave. The coefficient of $\cos k(at+x)$ is thus altered by the

* 'Theory of Sound,' 2nd ed. § 334.

particles in the layer dx from unity to $(1 - \frac{7}{8}k^4c^6\pi ndx)$, and the coefficient of $\sin k(at+x)$ from 0 to $\frac{1}{3}kc^3\pi ndx$. Thus, if E be the energy of the primary wave,

$$dE/E = -\frac{7}{8}k^4c^6\pi ndx ;$$

so that if, as in (4), $E = E_0 e^{-hx}$,

$$h = \frac{7}{8}\pi nk^4c^6. \quad . \quad . \quad . \quad . \quad . \quad (19)$$

The same result may be obtained indirectly from the *first* term of (15). For the whole energy emitted from one sphere may be reckoned as

$$\frac{k^4c^6}{9r^2} \int_{-1}^{+1} 2\pi r^2 (1 + \frac{3}{2}\mu)^2 d\mu = \frac{7\pi k^4c^6}{9}, \quad . \quad . \quad . \quad (20)$$

unity representing the energy of the primary wave per unit area of wave-front. From (20) we deduce the same value of h as in (19).

The first term of (18) gives the refractivity of the medium. If δ be the retardation due to the spheres of the stratum dx ,

$$\sin k\delta = \frac{1}{3}kc^3\pi ndx,$$

or
$$\delta = \frac{1}{3}\pi nc^3dx. \quad . \quad . \quad . \quad . \quad . \quad (21)$$

Thus, if μ be the refractive index as modified by the spheres, that of the original medium being unity,

$$\mu - 1 = \frac{1}{3}\pi nc^3 = \frac{1}{4}p, \quad . \quad . \quad . \quad . \quad . \quad (22)$$

where p denotes the (small) ratio of the volume occupied by the spheres to the whole volume. This result agrees with equations formerly obtained for the refractivity of a medium containing spherical obstacles disposed in cubic order*.

Let us now inquire what degree of transparency of air is admitted by its molecular constitution, *i. e.*, in the absence of all foreign matter. We may take $\lambda = 6 \times 10^{-5}$ centim., $\mu - 1 = .0003$; whence from (14) we obtain as the distance x , equal to $1/h$, which light must travel in order to undergo attenuation in the ratio $e : 1$,

$$x = 4.4 \times 10^{-13} \times n. \quad . \quad . \quad . \quad . \quad . \quad (23)$$

The completion of the calculation requires the value of n . Unfortunately this number—according to Avogadro's law the same for all gases—can hardly be regarded as known. Maxwell † estimates the number of molecules under standard

* Phil. Mag. vol. xxxiv. p. 499 (1892). Suppose $m = \infty$, $\sigma = \infty$.

† "Molecules," Nature, viii. p. 440 (1873).

conditions as 19×10^{18} per cub. centim. If we use this value of n , we find

$$x = 8.3 \times 10^6 \text{ cm.} = 83 \text{ kilometres,}$$

as the distance through which light must pass through air at atmospheric pressure before its intensity is reduced in the ratio of 2.7 : 1.

Although Mount Everest appears fairly bright at 100 miles distance as seen from the neighbourhood of Darjeeling, we cannot suppose that the atmosphere is as transparent as is implied in the above numbers; and of course this is not to be expected, since there is certainly suspended matter to be reckoned with. Perhaps the best data for a comparison are those afforded by the varying brightness of stars at various altitudes. Bouguer and others estimate about .8 for the transmission of light through the entire atmosphere from a star in the zenith. This corresponds to 8.3 kilometres of air at standard pressure. At this rate the transmission through 83 kilometres would be $(.8)^{10}$, or .11, instead of $1/e$ or .37. It appears then that the actual transmission through 83 kilometres is only about 3 times less than that calculated (with the above value of n) from molecular diffraction without any allowance for foreign matter at all. And we may conclude that the light scattered from the molecules would suffice to give us a blue sky, not so very greatly darker than that actually enjoyed.

If n be regarded as altogether unknown, we may reverse our argument, and we then arrive at the conclusion that n cannot be greatly less than was estimated by Maxwell. A lower limit for n , say 7×10^{18} per cubic centimetre, is somewhat sharply indicated. For a still smaller value, or rather the increased individual efficacy which according to the observed refraction would be its accompaniment, must lead to a less degree of transparency than is actually found. When we take into account the known presence of foreign matter, we shall probably see no ground for any reduction of Maxwell's number.

The results which we have obtained are based upon (14), and are as true as the theories from which that equation was derived. In the electromagnetic theory we have treated the molecules as spherical continuous bodies differing from the rest of the medium merely in the value of their dielectric constant. If we abandon the restriction as to sphericity, the results will be modified in a manner that cannot be precisely defined until the shape is specified. On the whole, however, it does not appear probable that this consideration would greatly affect the calculation as to transparency, since the particles

must be supposed to be oriented in all directions indifferently. But the theoretical conclusion that the light diffracted in a direction perpendicular to the primary rays should be *completely* polarized may well be seriously disturbed. If the view, suggested in the present paper, that a large part of the light from the sky is diffracted from the molecules themselves, be correct, the observed incomplete polarization at 90° from the Sun may be partly due to the molecules behaving rather as elongated bodies with indifferent orientation than as spheres of homogeneous material.

Again, the suppositions upon which we have proceeded give no account of *dispersion*. That the refraction of gases increases as the wave-length diminishes is an observed fact; and it is probable that the relation between refraction and transparency expressed in (14) holds good for each wave-length. If so, the falling off of transparency at the blue end of the spectrum will be even more marked than according to the inverse fourth power of the wave-length.

An interesting question arises as to whether (14) can be applied to highly compressed gases and to liquids or solids. Since approximately $(\mu - 1)$ is proportional to n , so also is h according to (14). We have no reason to suppose that the purest water is any more transparent than (14) would indicate; but it is more than doubtful whether the calculations are applicable to such a case, where the fundamental supposition, that the phases are entirely at random, is violated. When the volume occupied by the molecules is no longer very small compared with the whole volume, the fact that two molecules cannot occupy the same space detracts from the random character of the distribution. And when, as in liquids and solids, there is some approach to a regular spacing, the scattered light must be much less than upon a theory of random distribution.

Hitherto we have considered the case of obstacles small compared to the wave-length. In conclusion it may not be inappropriate to make a few remarks upon the opposite extreme case and to consider briefly the obstruction presented, for example, by a shower of rain, where the diameters of the drops are large multiples of the wave-length of light.

The full solution of the problem presented by spherical drops of water would include the theory of the rainbow, and if practicable at all would be a very complicated matter. But so far as the direct light is concerned, it would seem to make little difference whether we have to do with a spherical refracting drop, or with an opaque disk of the same diameter.

Let us suppose then that a large number of small disks are distributed at random over a plane parallel to a wave-front, and let us consider their effect upon the direct light at a great distance behind. The plane of the disks may be divided into a system of Fresnel's zones, each of which will by hypothesis include a large number of disks. If α be the area of each disk, and ν the number distributed per unit of area of the plane, the efficiency of each zone is diminished in the ratio $1 : 1 - \nu\alpha$, and, so far as the direct wave is concerned, this is the only effect. The *amplitude* of the direct wave is accordingly reduced in the ratio $1 : 1 - \nu\alpha$, or, if we denote the relative opaque area by m , in the ratio $1 : 1 - m^*$. A second operation of the same kind will reduce the amplitude to $(1 - m)^2$, and so on. After x passages the amplitude is $(1 - m)^x$, which if m be very small may be equated to e^{-mx} . Here mx denotes the whole opaque area passed, reckoned per unit area of wave-front; and it would seem that the result is applicable to any sufficiently sparse random distribution of obstacles.

It may be of interest to give a numerical example. If the unit of length be the centimetre and x the distance travelled, m will denote the projected area of the drops situated in one cubic centimetre. Suppose now that a is the radius of a drop, and n the number of drops per cubic centimetre, then $m = n\pi a^2$. The distance required to reduce the *amplitude* in the ratio $e : 1$ is given by

$$x = 1/n\pi a^2.$$

Suppose that $a = \frac{1}{20}$ centim., then the above-named reduction will occur in a distance of one kilometre ($x = 10^5$) when n is about 10^{-3} , *i.e.* when there is about one drop of one millimetre diameter per litre.

It should be noticed that according to this theory a distant point of light seen through a shower of rain ultimately becomes invisible, not by failure of definition, but by loss of intensity either absolutely or relatively to the scattered light.

* The *intensity* of the direct wave is $1 - 2m$, and that of the scattered light m , making altogether $1 - m$.

XXXV. *On Opacity.* By Professor OLIVER LODGE, *D.Sc.*,
LL.D., *F.R.S.*, *President of the Physical Society**.

MY attention has recently been called to the subject of the transmission of electromagnetic waves by conducting dielectrics—in other words, to the opacity of imperfectly conducting material to light. The question arose when an attempt was being made to signal inductively through a stratum of earth or sea, how far the intervening layers of moderately conducting material were able to act as a screen; the question also arises in the transmission of Hertz waves through partial conductors, and again in the transparency of gold-leaf and other homogeneous substances to light.

The earliest treatment of such subjects is due of course to Clerk Maxwell thirty-four years ago, when, with unexampled genius, he laid down the fundamental laws for the propagation of electric waves in simple dielectrics, in crystalline media, and in conducting media. He also realised there was some strong analogy between the transmission of such waves through space and the transmission of pulses of current along a telegraph-wire. But naturally at that early date not every detail of the investigation was equally satisfactory and complete.

Since that time, and using Maxwell as a basis, several mathematicians have developed the theory further, and no one with more comprehensive thoroughness than Mr. Oliver Heaviside, who, as I have said before, has gone into these matters with extraordinarily clear and far vision. I may take the opportunity of calling or recalling to the notice of the Society, as well as of myself, some of the simpler developments of Mr. Heaviside's theory and manner of unifying phenomena and processes at first sight apparently different; but first I will deal with the better-known aspects of the subject.

Maxwell deals with the relation between conductivity and opacity in his Art. 798 and on practically to the end of that famous chapter xx. ('Electromagnetic Theory of Light'). He discriminates, though not very explicitly or obtrusively, between the two extreme cases, (1) when inductive capacity or electric inductivity is the dominant feature of the medium—when, for instance, it is a slightly conducting dielectric, and (2) the other extreme case, when conductivity is the predominant feature.

* Communicated by the Physical Society of London, being the Presidential Address for 1899.

The equation for the second case, that of predominant conductivity, is

$$\frac{d^2F}{dx^2} = \frac{4\pi\mu}{\sigma} \frac{dF}{dt}, \quad \dots \dots \dots (1)$$

F being practically any vector representing the amplitude of the disturbance ; for since we need not trouble ourselves with geometrical considerations such as the oblique incidence of waves on a boundary &c., we are at liberty to write the ∇ merely as d/dx , taking the beam parallel and the incidence normal.

No examples are given by Maxwell of the solution of this equation, because it is obviously analogous to the ordinary heat diffusion fully treated by Fourier.

Suffice it for us to say that, taking F at the origin as represented by a simple harmonic disturbance $F_0 = e^{ipt}$, the solution of equation (1)

$$\frac{d^2F}{dx^2} = \frac{4\pi\mu ip}{\sigma} F \dots \dots \dots (1')$$

is $F = F_0 e^{-Qx} = e^{-Qx + ipt}$,

where $Q = \sqrt{\left(\frac{4\pi\mu ip}{\sigma}\right)} = \sqrt{\frac{2\pi\mu p}{\sigma}} \cdot (1 + i)$;

wherefore

$$F = e^{-\left(\frac{2\pi\mu p}{\sigma}\right)^{\frac{1}{2}}x} \cos \left(pt - \left(\frac{2\pi\mu p}{\sigma}\right)^{\frac{1}{2}}x \right), \quad \dots \dots (2)$$

an equation which exhibits no true elastic wave propagation at a definite velocity, but a trailing and distorted progress, with every harmonic constituent going at a different pace, and dying out at a different rate ; in other words, the *diffusion* so well known in the case of the variable stage of heat-conduction through a slab.

In such conduction the gain of heat by any element whose heat capacity is $cp dx$ is proportional to the difference of the temperature gradient at its fore and aft surfaces, so that

$$cp dx \frac{d\theta}{dt} = d \cdot k \frac{d\theta}{dx},$$

or, what is the same thing,

$$\frac{d^2\theta}{dx^2} = \frac{cp}{k} \frac{d\theta}{dt},$$

the same as the equation (1) above ; wherefore the constant cp/k , the *reciprocal* of the thermometric conductivity, takes the

place of $4\pi\mu/\sigma$, that is, of electric conductivity; otherwise the heat solution is the same as (2). The 4π has come in from an unfortunate convention, but it is remarkable that the conductivity term is inverted. The reason of the inversion of this constant is that, whereas the *substance* conveys the heat waves, and by its conductivity aids their advance, the *æther* conveys the electric waves, and the substance only screens and opposes, reflects, or dissipates them.

This is the case applied to sea-water and low frequency by Mr. Whitehead in a paper which he gave to this Society in June 1897, being prompted thereto by the difficulty which Mr. Evershed and the Post Office had found in some trials of induction signalling at the Goodwin Sands between a coil round a ship at the surface and another coil submerged at a depth of 10 or 12 fathoms. It was suspected that the conductivity of the water mopped up a considerable proportion of the induced currents, and Mr. Whitehead's calculation tended, or was held to tend, to support that conclusion.

To the discussion Mr. Heaviside communicated what was apparently, as reported, a brief statement; but I learn that in reality it was a carefully written note of three pages, which recently he has been good enough to lend me a copy of. In that note he calls attention to a theory of the whole subject which in 1887 he had worked out and printed in his collected 'Electrical Papers,' but which has very likely been overlooked. It seems to me a pity that a note by Mr. Heaviside should have been so abridged in the reported discussion as to be practically useless; and I am permitted to quote it here as an appendix (p. 413).

Meanwhile, taking the diffusion case as applicable to sea-water with moderately low acoustic frequency, we see that the induction effect decreases geometrically with the thickness of the oceanic layer, and that the logarithmic decrement of the amplitude of the oscillation is $\sqrt{\left(\frac{2\pi\mu p}{\sigma}\right)}$, where σ is the specific resistance of sea-water and $p/2\pi$ is the frequency.

Mr. Evershed has measured σ and found it 2×10^{10} c.g.s., that is to say $2 \times 10^{10} \mu$ square centim. per second; so putting in this value and taking a frequency of 16 per second, the amplitude is reduced to $1/e^{\text{th}}$ of what its value would have been at the same distance in a perfect insulator, by a depth

$$\sqrt{\frac{\sigma}{2\pi\mu p}} = \sqrt{\left(\frac{2 \times 10^{10}\mu}{2\pi\mu \times 2\pi \times 16}\right)} = \sqrt{\frac{10^{10}}{320}} = \frac{10^5}{18} \text{ centim.} \\ = 55 \text{ metres.}$$

Four or five times this thickness of intervening sea would

reduce the result at the 16 frequency to insignificance (each 55-metre-layer reducing the energy to $\frac{1}{7}$ of what entered it); but if the frequency were, say, 400 per second instead of 16 it would be five times more damped, and the damping thickness (the depth reducing the amplitude in the ratio $e:1$) would in that case be only eleven metres.

It is clear that in a sea 10 fathoms (or say 20 metres) deep the failure to inductively operate a "call" responding to a frequency of 16 per second was *not* due to the screening effect of sea-water*.

Maxwell, however, is more interested in the propagation of actual light, that is to say, in waves whose frequency is about 5×10^{14} per second; and for that he evidently does not consider that the simple diffusion theory is suitable. It certainly is not applicable to light passing through so feeble a conductor as salt water. He attends mainly therefore to the other and more interesting case, where electric inductive-capacity predominates over the damping effect of conductivity, and where true waves therefore advance with an approximately definite velocity

$$v = \frac{1}{\sqrt{\mu K}};$$

though it is to be noted that the slight sorting out of waves of different frequency, called dispersion, is an approximation to the case of pure diffusion where the speed is as the square root of the frequency, and is accompanied, moreover, as it ought to be, by a certain amount of differential or selective absorption.

To treat the case of waves in a conductor, the same damping term as before has to be added to the ordinary wave equation, and so we have

$$\frac{d^2 F}{dx^2} = \mu K \frac{d^2 F}{dt^2} + \frac{4\pi\mu}{\sigma} \frac{dF}{dt} \dots \dots \dots (3)$$

Taking $F_0 = e^{ipt}$ again, it may be written

$$\frac{d^2 F}{dx^2} = \left(-\mu K p^2 + \frac{4\pi\mu ip}{\sigma} \right) F, \dots \dots \dots (3')$$

the same form as equation (1'); so the solution is again

$$F = e^{-Qx + ipt},$$

* I learn that the ship supporting the secondary cable was of metal, and that the primary or submerged cable was sheathed in uninsulated metal, viz. in iron, which would no doubt be practically short-circuited by the sea-water. Opacity of the medium is in that case a superfluous explanation of the failure, since a closed secondary existed close to both sending and receiving circuit.

with Q^2 equal to the coefficient of F in (3'). Maxwell, however, does not happen to extract the square root of this quantity, but, assuming the answer to be of the form (for a simply harmonic disturbance) [modifying his letters, vol. ii. § 798]

$$e^{-rx} \cos (pt - qx),$$

he differentiates and equates coefficients, thus getting

$$q^2 - r^2 = \mu K p^2, \quad 2rq = \frac{4\pi\mu p}{\sigma},$$

as the conditions enabling it to satisfy the differential equation. This of course gives for the logarithmic decrement, or coefficient of absorption,

$$r = \frac{2\pi\mu}{\sigma} \cdot \frac{p}{q},$$

p/q being precisely the velocity of propagation of the train of waves. Though not exactly equal to $1/\sqrt{\mu K}$, the true velocity of wave propagation, except as a first approximation, in an absorbing medium, yet practically this velocity p/q or λ/T is independent of the frequency except in strongly absorbent substances where there are dispersional complications; and so the damping is, in simple cases, practically independent of the frequency too.

With this simple velocity in mind Maxwell proceeds to apply his theory numerically to gold-leaf, calculating its theoretical transparency, and finding, as every one knows, that it comes out discordant with experiment, being out of all comparison* smaller than what experiment gives.

But then it is somewhat surprising to find gold treated as a substance in which conductivity does not predominate over specific inductive capacity.

The differential equation is quite general and applies to any substance, and since the solution given is a true solution, it too must apply to any substance when properly interpreted; but writing it in the form just given does not suggest the full and complete solution. It seems to apply only to slightly damped waves, and indeed, Maxwell seems to consider it desirable to rewrite the original equation with omission of K , for the purpose of dealing with good conductors.

By a slip, however, he treats gold for the moment as if it belonged to the category of poor conductors, and as if absorption in a thickness such as gold-leaf could be treated as a moderate damping of otherwise progressive waves.

* The fraction representing the calculated transmission by a film half a wave thick has two thousand digits in its denominator; see below.

The slip was naturally due to a consideration of the extreme frequency of light vibrations; but attention to the more complete expression for the solution of the same differential equation, given in 1887 by Mr. Heaviside and quoted in the note to this Society above referred to, puts the matter in a proper position. Referring to his 'Electrical Papers,' vol. ii. p. 422, he writes down the general value of the coefficient of absorption as follows (translating into our notation)

$$r = \frac{p}{v\sqrt{2}} \left\{ \left[1 + \left(\frac{4\pi}{\sigma p K} \right)^2 \right]^{\frac{1}{2}} - 1 \right\}^{\frac{1}{2}}$$

without regard to whether the conductivity of the medium is large or small; where v is the undamped or true velocity of wave propagation in the medium $(\mu K)^{-\frac{1}{2}}$.

Of course Maxwell could have got this expression in an instant by extracting the square root of the quantity Q , the coefficient of F in equation (3') written above. I do not suppose that there is anything of the slightest interest from the mathematician's point of view, the interest lies in the physical application; but as this is not a mathematical Society it is permissible, and I believe proper, to indicate steps for the working out of the general solution of equation (3) by extracting the square root of the complex quantity Q .

The equation is

$$\frac{d^2 F}{dx^2} + \left(\mu K p^2 - \frac{4\pi \mu i p}{\sigma} \right) F = 0,$$

and the solution is

$$F = e^{-Qx + ipt},$$

where

$$Q = \sqrt{-\mu K p^2 + \frac{4\pi \mu i p}{\sigma}} = \alpha + i\beta \text{ say.}$$

Squaring we get, just as Maxwell did,

$$\alpha^2 - \beta^2 = -\mu K p^2, \quad 2\alpha\beta = +\frac{4\pi \mu p}{\sigma}.$$

Squaring again and adding

$$(\alpha^2 + \beta^2)^2 = (\alpha^2 - \beta^2)^2 + 4\alpha^2\beta^2 = \mu^2 K^2 p^4 + \frac{16\pi^2 \mu^2 p^2}{\sigma^2}$$

$$\therefore \alpha^2 + \beta^2 = \mu K p^2 \left\{ 1 + \left(\frac{4\pi}{K p \sigma} \right)^2 \right\}^{\frac{1}{2}},$$

wherefore

$$2\beta^2 = \mu K p^2 \left\{ \sqrt{\left(1 + \left(\frac{4\pi}{K p \sigma} \right)^2 \right)} + 1 \right\}, \quad \dots \quad (4)$$

and $2\alpha^2 =$ the same with the last sign negative,

$$\text{or } \alpha = p\sqrt{(\frac{1}{2} \mu K)} \left[\left\{ 1 + \left(\frac{4\pi}{\sigma p K} \right)^2 \right\}^{\frac{1}{2}} - 1 \right]^{\frac{1}{2}}, \dots \quad (5)$$

which is the logarithmic decrement of the oscillation per unit of distance, or the reciprocal of the thickness which reduces the amplitude in the ratio $1 : e$ (or the energy to $\frac{1}{e}$) of the value it would have at the same place without damping.

Using these values for α and β , the radiation-vector in general, after passing through any thickness x of any medium whose magnetic permeability and other properties are constant, is

$$F = F_0 e^{-\alpha x} \cos (pt - \beta x), \dots \quad (6)$$

the speed of advance of the wave-train being p/β .

Now not only the numerical value but the form of this damping constant α depends on the magnitude of the numerical quantity $\frac{4\pi}{\sigma p K}$, which may be called the critical number*, and may also be written

$$\frac{4\pi\mu_0 v_0^2}{p\sigma K/K_0}, \dots \quad (7)$$

where K , the absolute specific inductive capacity of the medium, is replaced by its relative value in terms of K_0 for vacuum, and by $\frac{1}{\sqrt{K_0\mu_0}}$ = the velocity of light *in vacuo* = v_0 .

Now for all ordinary frequencies and good conductors this critical number is large; and in that case it will be found that

$$\alpha = p\sqrt{\frac{\mu K}{2}} \cdot \sqrt{\frac{4\pi}{\sigma p K}} = \sqrt{\frac{2\pi\mu p}{\sigma}},$$

and that β is identically the same. This represents the simple diffusion case, and leads to equation (2).

On the other hand, for luminous frequency and bad conductors, the critical quantity is small, and in that case

$$\begin{aligned} \alpha &= p\sqrt{(\frac{1}{2} \mu K)} \left\{ 1 + \frac{1}{2} \left(\frac{4\pi}{\sigma p K} \right)^2 - 1 \right\}^{\frac{1}{2}} \\ &= \frac{1}{2} p\sqrt{(\mu K)} \cdot \frac{4\pi}{\sigma p K} = \frac{2\pi\mu v}{\sigma}, \end{aligned}$$

* An instructive mode of writing α and β in general is given in (11'') or (12'') below, where the above critical number is called $\tan \epsilon$:—

$$\begin{aligned} \alpha v \sqrt{\cos \epsilon} &= p \sin \frac{1}{2} \epsilon, \\ \beta v \sqrt{\cos \epsilon} &= p \cos \frac{1}{2} \epsilon. \end{aligned}$$

while

$$\beta = p \sqrt{\mu K} = \frac{p}{v},$$

giving the solution

$$F = F_0 e^{-\frac{2\pi\mu v}{\sigma} x} \cos p \left(t - \frac{x}{v} \right). \quad (8)$$

This expresses the transmission of light through imperfect insulators, and is the case specially applied by Maxwell to calculations of opacity. Its form serves likewise for telegraphic signals or Hertz waves transmitted by a highly-conducting aerial wire; the damping, if any, is independent of frequency and there is true undistorted wave-propagation at velocity $v = 1/\sqrt{LS}$; the constants belonging to unit length of the wire. The current (or potential) at any time and place is

$$C = C_0 e^{-\frac{Rx}{2Lv}} \cos p(t - x \sqrt{LS}). \quad (9)$$

The other extreme case, that of diffusion, represented by equation (2), is analogous to the well-known transmission of slow signals by Atlantic cables, that is by long cables where resistance and capacity are predominant, giving the so-called KR law (only that I will write it RS),

$$C = C_0 e^{-\sqrt{(\frac{1}{2}pRS)x}} \cos \{pt - \sqrt{(\frac{1}{2}pRS)x}\}; \quad (10)$$

wherefore the damping distance in a cable is

$$x_0 = \sqrt{\left(\frac{2}{pRS} \right)}.$$

Thus, in comparing the cable case with the penetration of waves into a conductor and with the case of thermal conduction, the following quantities correspond :

$$\frac{1}{2}pRS, \quad \frac{4\pi\mu p}{2\sigma}, \quad \frac{p c \rho}{2k}.$$

$c\rho$ is the heat-capacity per unit volume, S is the electric capacity per unit length; k is the thermal conductivity per unit volume, $1/R$ is the electric conductance per unit length. So these agree exactly; but in the middle case, that of waves entering a conductor, there is a notable inversion, representing a real physical fact. $4\pi\mu$ may be called the density and may be compared with ρ or with $1/S$, that is with elasticity $\div v^2$; but σ is the *resistance* per unit volume instead of the conductance. The reason of course is that whereas good conductivity helps the cable-signals or the heat along, it by no means helps the waves into the conductor. Conductivity aids

their slipping *along* the boundary of a conductor, but it retards their passing *across* the boundary and entering a conductor. As regards waves entering a conductor, the effect of conductivity is a screening effect, not a transmitting effect, and it is the bad conductor which alone has a chance of being a transparent medium.

It may be convenient to telegraphists, accustomed to think in terms of the "KR-law" and comparing equations (2) and (10), to note that the quantity $4\pi\mu/\sigma$ —that is, practically, the specific conductivity in electromagnetic measure (multiplied by a meaningless 4π because of an unfortunate initial convention)—takes the place of KR (*i. e.* of RS), but that otherwise the damping-out of the waves as they enter a good conductor is exactly like the damping-out of the signals as they progress through a cable; or again as electrification travels along a cotton thread, or as a temperature pulse makes its way through a slab; and yet another case, though it is different in many respects, yet has some similarities, viz. the ultimate distance the melting-point of wax travels along a bar in Ingenhousz's conductivity apparatus,—the same law of inverse square of distance for effective reach of signal holding in each case.

Now it is pointed out by Mr. Heaviside in several places in his writings that, whereas the transmission of high-frequency waves by a nearly transparent substance corresponds by analogy to the conveyance of Hertz waves along aerial wires (or along cables for that matter, if sufficiently conducting), and whereas the absorption of low-frequency waves by a conducting substance corresponds, also by analogy, to the diffusion of pulses along a telegraph-cable whose self-induction is neglected—its resistance and capacity being prominent,—the intermediate case of waves of moderate frequency in a conductor of intermediate opacity corresponds to the more general cable case where self-induction becomes important and where leakage also must be taken into account; because it is leakage conductance that is the conductance of the dielectric concerned in plane waves. This last is therefore a real, and not only an analogic, correspondence.

Writing $R_1 S_1 L_1 Q_1$ for the resistance, the capacity ("permittance"), the inductance, and the leakage-conductance ("leakance") respectively, per unit length, the general equations to cable-signalling are given in Mr. Heaviside's 'Electromagnetic Theory' thus:—

$$S_1 \frac{dV}{dt} + Q_1 V + \frac{dC}{dx} = 0, \quad L_1 \frac{dC}{dt} + R_1 C + \frac{dV}{dx} = 0;$$

or for a simple harmonic disturbance,

$$\begin{aligned} \frac{d^2V}{dx^2} &= (R_1 + ipL_1)(Q_1 + ipS_1)V \dots (11) \\ &= (\alpha + i\beta)^2V, \end{aligned}$$

whose solution therefore is

$$V = V_0 e^{-\alpha x} \cos (pt - \beta x) * \dots (11')$$

There are several interesting special cases:—

The old cable theory of Lord Kelvin is obtained by omitting both Q and L; thus getting equation (2).

The transmission of Hertz waves along a perfectly-conducting insulated wire is obtained by omitting Q and R; the speed of such transmission being $1/\sqrt{L_1S_1}$. Resistance in the wire brings it to the form (9), where the damping depends on the ratio of the capacity constant RS to the self-induction constant L/S; because the index $R/2Lx$ equals half the square root of this ratio; but it must be remembered that R has the throttled value due to merely superficial penetration. The case is approximated to in telephony sometimes.

A remarkable case of undistorted (though attenuated) transmission through a cable (discovered by Mr. Heaviside, but not yet practically applied) is obtained by taking

$$R/L = Q/S = r;$$

the solution being then

$$V = e^{-\frac{rx}{v}} f\left(t - \frac{x}{v}\right),$$

due to $f(t)$ at $x=0$. All frequencies are thus treated alike, and a true velocity of transmission makes its reappearance. This is what he calls his “distortionless circuit,” which may yet play an important part in practice.

And lastly, the two cases which for brevity may be treated together, the case of perfect insulation, $Q=0$, on the one hand, and the case of perfect wire conduction, $R=0$, on the other. For either of these cases the general expression

$$\alpha^2 \text{ or } \beta^2 = \frac{1}{2}p^2L_1S_1 \left[\left\{ 1 + \left(\frac{R}{pL}\right)^2 \right\}^{\frac{1}{2}} \left\{ 1 + \left(\frac{Q}{pS}\right)^2 \right\}^{\frac{1}{2}} \pm \left\{ \frac{RQ}{p^2LS} - 1 \right\} \right] \quad (12)$$

* I don't know whether the following simple general expression for α and β has been recorded by anyone: writing $R/pL = \tan \epsilon$ and $Q/pS = \tan \epsilon'$,

$$\alpha \text{ or } \beta = \frac{p}{v} \cdot \frac{\sin \text{ or } \cos \frac{1}{2}(\epsilon + \epsilon')}{(\cos \epsilon \cos \epsilon')^{\frac{1}{2}}}, \dots (11'')$$

which is shorter than (12).

becomes exactly of the form (4) or (5) reckoned above for the general screening-effect, or opacity, of conducting media in space.

For the number which takes the place of the quantity there called the critical number, namely either R/pL or Q/pS , the other being zero, we may write $\tan \epsilon$; in which case the above is

$$\alpha^2 \text{ or } \beta^2 = \frac{1}{2} p^2 L_1 S_1 (\sec \epsilon \mp 1); \dots \dots \dots (12')$$

or, rewriting in a sufficiently obvious manner, with $2\pi/\lambda$ for p/v if we choose,

$$\alpha = \frac{p \sin \frac{1}{2}\epsilon}{v(\cos \epsilon)^{\frac{3}{2}}}, \quad \beta = \frac{p \cos \frac{1}{2}\epsilon}{v(\cos \epsilon)^{\frac{1}{2}}}. \dots \dots \dots (12'')$$

Instead of attending to special cases, if we attend to the general cable equation (11) as it stands, we see that it is more general than the corresponding equation (3) to waves in space, because it contains the extra possibility R of wire resistance, which does not exist in free space.

Mr. Heaviside, however, prefers to unify the whole by the introduction of a hypothetical and as yet undiscovered dissipation-possibility in space, or in material bodies occupying space, which he calls magnetic conductance, and which, though supposed to be non-existent, may perhaps conceivably represent the reciprocal of some kind of hysteresis, either the electric or the magnetic variety. Calling this g , (gH^2 is to be the dissipation term corresponding with RC^2), the equation to waves in space becomes

$$\nabla^2 F = (g + ip\mu) \left(\frac{4\pi}{\sigma} + ipK \right) F, \dots \dots \dots (13)$$

just like the general cable case. And a curious kind of transparency, attenuation without distortion, would belong to a medium in which both conductivities coexisted in such proportion that $g : \mu = 4\pi k : K$; for g would destroy H just as k destroys E .

In the cable, F may be either current or potential, and $LSv^2 = 1$. In space, F may be either electric or magnetic intensity, and $\mu K v^2 = 1$; but observe that g takes the place not of Q but of R , while it is $4\pi/\sigma$ that takes the place of Q . Resistance in the wire and electric conductivity in space do not produce similar effects. If there is any analogue in space to wire resistance it is magnetic not electric conductivity.

The important thing is of course that the wire does not convey the energy but dissipates it, so that the dissipation by wire-resistance and the dissipation by space-hysteresis to

that extent correspond. The screening effect of space-conductivity involves the very same dielectric property as that which causes leakage or imperfect insulation of the cable core.

Returning to the imaginary magnetic conductivity, let us trace what its effects would be if it existed, and try to grasp it. Its effect would be to kill out the magnetism of permanent magnets in time, and generally to waste away the energy of a static magnetic field, just as resistance in wires wastes the energy of an unmaintained current and so kills out the magnetism of *its* field. I spoke above as if it were conceivable that such magnetic conductivity could actually in some degree exist, likening it to a kind of hysteresis; but hysteresis—the enclosure of a loop between a to and fro path—is a phenomenon essentially associated with *fluctuations*, and cannot exist in a steady field with everything stationary. Admitted: but then the molecules are not stationary, and the behaviour of molecules in the Zeeman and Righi phenomena, or still more strikingly in the gratuitous radiations discovered by Edmond Becquerel, and more widely recognized by others, especially by Monsieur et Madame Curie, (not really gratuitous but effected probably by conversion into high-pitched radiation of energy supplied from low-pitched sources),—the way molecules of absorbent substances behave, seems to render possible, or at least conceivable, something like a minute magnetic conductivity in radiative or absorptive substances. Mr. Heaviside, however, never introduced it as a physical fact for which there was any experimental evidence, but as a physical possibility and especially as a mathematical auxiliary and unifier of treatment, and that is all that we need here consider it to be; but we may trace in rather more detail its effect if it did exist.

Suppose the magnetism of a magnet decayed, what would happen to its lines of force? They would gradually shrink into smaller loops and ultimately into molecular ones. The generation of a magnetic field is always the opening out of previously existing molecular magnetic loops; there is no such thing as the creation of a magnetic field, except in the sense of moving it into a fresh place or expanding it over a wider region*. So also the destruction of a magnetic field merely means the shrinkage of its lines of force (or lines of induction, I am not here discriminating between them). Now consider an electric current in a wire:—a cylindrical magnetic field surrounds it, and if the current gradually decreases in strength the magnetic energy gradually sinks into

* This may be disagreed with.

the wire as its lines slowly collapse. But observe that the *electric* energy of the field remains unchanged by this process: if the wire were electrostatically charged it would remain charged, its average potential can remain constant. Let the wire for instance be perfectly conducting, then the current needs no maintenance, the potential might be uniform (though in general there would be waves running to and fro), and both the electric and magnetic fields continue for ever, unless there is some dissipative property in space.

Two kinds of dissipative property may be imagined in matter filling space: first, and most ordinary, an electric conductivity or simple leakage, the result of which will be to equalize the potential throughout space and destroy the electric field, without necessarily affecting the magnetic field, and so without stopping the steady circulation of the current manifested by that field. The other dissipative property in space that could be imagined would be magnetic conductivity; the result of which would be to shrink all the circular lines of magnetic force slowly upon the wire, thus destroying the magnetic field, and with it (by the circuital relation) the current; but leaving the electrostatic potential and the electric field unchanged. And this imaginary effect of the medium in surrounding space is exactly the real effect caused by what is called electric resistance in the wire*.

Now for a simply progressive undistorted wave, *i. e.* one with no character of diffusion about it, but all frequencies travelling at the same quite definite speed $1/\sqrt{\mu K}$, it is essential that the electric and magnetic energies shall be equal. If both are weakened *in the same proportion*, the wave-energy is diminished, and the pulse is said to be "attenuated," but it continues otherwise uninjured and arrives "undistorted," that is, with all its features intact and at the same speed as before, but on a reduced scale in point of size.

This is the case of Mr. Heaviside's "distortionless circuit" spoken of above, and its practical realization in cables, though it would not at once mean Atlantic telephony, would mean greatly improved signalling, and probably telephony through shorter cables. In a cable the length of the Atlantic the attenuation would be excessive, unless the absence of distortion were secured by increasing rather the wire-conductance than the dielectric leakage; but, unless excessive, simple attenua-

* There is this difference, that in the real case the heat of dissipation appears locally in the wire, whereas in the imaginary case it appears throughout the magnetically conducting medium; but I apprehend that in the imaginary case the lines would still shrink, by reason of molecular loops being pinched off them.

tion does no serious harm. Articulation depends on the features of the wave, and the preservation of the features demands, by Fourier's analysis, the transmission of every frequency at the same rate.

But now suppose any cause diminishes one of the two fields without diminishing the other: for instance, let the electric field be weakened by leakage alone, or let the magnetic field be weakened by wire-resistance alone, then what happens? The preservation of E and the diminution of H , to take the latter—the ordinary—case, may be regarded as a superposition on the advancing wave of a gradually growing reverse field of intensity δH ; and, by the relation $E = \mu v H$, this reversed field, for whatever it is worth, must mean a gradually growing wave travelling in the reverse direction.

The ordinary wave is now no longer left alone and uninjured, it has superposed upon itself a more or less strong reflected wave, a reflected wave which constantly increases in intensity as the distance along the cable, or the penetration of the wave into a conducting medium, increases; all the elementary reflected waves get mixed up by re-reflexion in the rear, constituting what Mr. Heaviside calls a diffusive "tail"; and this accumulation of reflected waves it is which constitutes what is known as "distortion" in cables, and what is known as "opacity" inside conducting dielectrics.

There is another kind of opacity, a kind due to heterogeneity, not connected with conductivity but due merely to a change in the constants K and μ ,—properly a kind of translucency, a scattering but not a dissipation of energy,—like the opacity of foam or ground glass.

This kind of opacity is an affair of boundaries and not of the medium itself, but after all, as we now see, it has features by no means altogether dissimilar to the truer kind of opacity. Conducting opacity is due to reflexion, translucent opacity is due to reflexion,—to irregular reflexion as it is called, but of course there is nothing irregular about the reflexion, it is only the distribution of boundaries which is complicated, the reflexion is as simple as ever;—except, indeed, to some extent when the *size* of the scattering particles has to be taken into account and the blue of the sky emerges. But my point is that this kind of opacity also is after all of the reflexion kind, and the gradual destruction of the advancing wave—whether it be by dust in the air or, as Lord Rayleigh now suggests, perhaps by the discrete molecules themselves, by the same molecular property as causes refraction and dispersion—must result in a minute distortion and a mode of wave propagation not wholly different from cable-signalling

or from the transmission of light through conductors. So that the red of the sunset sky and the green of gold-leaf may not be after all very different; nor is the arrival-curve of a telegraph signal a wholly distinct phenomenon.

There is a third kind of opacity, that of lampblack, where the molecules appear to take up the energy direct, converting it into their own motion, that is into heat, and where there appears to be little or nothing of the nature of reflexion. I am not prepared to discuss that kind at present.

It is interesting to note that in the most resisting and capacious cable that ever was made, where all the features of every wave arrive as obliterated as if one were trying to signal by heat-pulses through a slab, that even there the *head* of every wave travels undistorted, with the velocity of light, and suffers nothing but attenuation; for the superposed reversed field is only called out by the arrival of the direct pulse, and never absolutely reaches the strength of the direct field. The attenuation may be excessive, but the signal is there in its right time if only we have a sensitive enough instrument to detect it; though it would be practically useless as a signal in so extreme a case, being practically *all tail*.

Nothing at all reaches the distant end till the light-speed-time has elapsed; and the light-speed-time in a cable depends on the μ and K of its insulating sheath, depends, if that is not simply cylindrical, on the product of its self-inductance and capacity per unit length; but at the expiration of the light-speed-time the head of the signalling pulse arrives, and neither wire-resistance nor insulation-leakage, no, nor magnetic-conductivity, can do anything either to retard it or to injure its sharpness: they can only enfeeble its strength, but they can do that very effectually.

The transmitter of the pulse is self-induction in conjunction with capacity: the chief practical enfeebler of the pulse is wire-resistance in conjunction with capacity; and before Atlantic telephony is possible (unless a really distortionless cable is forthcoming) the copper core of an ordinary cable will have to be made much larger. Nothing more is wanted in order that telephony to America may be achieved. There may be practical difficulties connected with the mechanical stiffness of a stout core and the worrying of its guttapercha sheath, and these difficulties may have to be lessened by aiming at distortionless conditions—it is well known also that for high frequencies a stout core must be composed of insulated strands unless it is hollow—but when such telephony is accomplished, I hope it will be recollected that the full and complete principles of it and of a great deal else connected with tele-

graphy have been elaborately and thoroughly laid down by Mr. Heaviside.

There is a paragraph in Maxwell, concerning the way a current rises in a conductor and affects the surrounding space, which is by no means satisfactory: it is Art. 804. He takes the current as starting all along the wire, setting up a sheath of opposition induced currents in the surrounding imperfectly insulating dielectric, which gradually diffuse outwards and die away, leaving at last the full inductive effect of the core-current to be felt at a distance. Thus there is supposed to be a diffusion of energy outwards from the wire, which he likens to the diffusion of heat.

But, as Mr. Heaviside has shown, the true phenomenon is the transmission of a wave in the space surrounding the wire—a plane wave if the wire is perfectly conducting, a slightly coned wave if it resists,—a wave-front perpendicular to the wire and travelling along it,—*a sort of beam of dark light with the wire as its core.*

Telegraphic signalling and optical signalling are similar; but whereas the beam of the heliograph is abandoned to space and must go straight except for reflexion and refraction, the telegraphic beam can follow the sinuosities of the wire and be guided to its destination.

If the medium conducts slightly it will be dissipated *in situ*; but if the wire conducts imperfectly, a minute trickle of energy is constantly directed inwards radially towards the wire core, there to be dissipated as heat. Parallel to the wire flows the main energy stream, but there is a small amount of tangential grazing and inward flow. The initial phenomenon does not occur in the wire, gradually to spread outwards, but it occurs in the surrounding medium, and a fraction of it gradually converges inwards. The advancing waves are not cylindrical but plane waves, and though the diffusing waves are cylindrical they advance inwards, not outwards.

I will quote from a letter of Mr. Heaviside's:—"The easiest way to make people understand is, perhaps, to start with a conducting dielectric with plane waves in it without wires, [thus getting] one kind of attenuation and distortion. Then introduce wires of *no* resistance; there is no difference except in the way the lines of force distribute [enabling the wires to guide the plane waves]. Then introduce magnetic conductivity in the medium, [thereby getting] the other kind of attenuation and distortion. Transfer it to the wires, making it electrical resistance. Then abolish the first electric conductivity, and you have the usual electric telegraph."

OPACITY OF GOLD-LEAF.

Now returning to the general solution (5) let us apply it to calculate the opacity of gold-leaf to light.

Take $\sigma = 2000 \mu$ square centim. per sec.,
 $p = 2\pi \times 5 \times 10^{14}$ per sec. ;

then the critical quantity $4\pi/p\sigma K$ or (7) is

$$\frac{2 \times 9 \times 10^{20}}{5 \times 10^{14} \times 2000 K/K_0} = \frac{1800}{K/K_0}.$$

This number is probably considerably bigger than unity (unless, indeed, the specific inductive capacity K/K_0 of gold is immensely large, which may indeed be the case—refractive index 40, for instance,—only it becomes rather difficult to define) ; so that, approximately,

$$\alpha = \sqrt{\left(\frac{2\pi\mu p}{\sigma}\right)} = \sqrt{\frac{40 \times 5 \times 10^{14}}{2000}} = \sqrt{10^{13}} = 3 \times 10^6 ;$$

or the damping distance is

$$\frac{1}{3} \times 10^{-5} \text{ centim.} = \frac{1}{3} \text{ microcentimetre,}$$

whereas the wave-length in air is

$$6 \times 10^{-5} \text{ centim.} = 60 \text{ microcentimetres.}$$

The damping distance is therefore getting nearer to the right order of magnitude, but the opacity is still excessive.

A common thickness for gold-leaf is stated to be half a wave-length of light ; that is to say, 90 times the damping distance. Hence the amplitude of the light which gets through a half-wave thickness of gold is e^{-90} of that which enters ; and that is sheer opacity.

[Maxwell's calculation in Art. 798, carried out numerically, makes the damping

$$e^{-\frac{2\pi\mu\sigma}{\sigma}x}, = \exp. (-10^8x) \text{ for gold,}$$

see equation (8) above ; or, for a thickness of half a wave-length, 10^{-1000} , which is billions of billions of billions (indeed a number with 960 digits) times greater opacity than what we have here calculated, and is certainly wrong.]

It must, however, be granted, I think, that the green light that emerges from gold-leaf is not properly transmitted ; it is light re-emitted by the gold *. The incident light, say the

* This would be fluorescence, of course ; and Dr. Larmor argues in favour of a simple ordinary exponential coefficient of absorption even in metals. See Phil. Trans. 1894, p. 738, § 27.

red, is all stopped by a thickness less than half a wave-length. The green light may conceivably be due to atoms vibrating fairly in concordance, and not calling out the conducting opacity of the metal. If the calculated opacity, notwithstanding this, is still too great, it is no use assuming a higher conductivity at higher frequency, for that would act the wrong way. What must be assumed is either some special molecular dispersion theory, or else greater specific resistance for oscillations of the frequency which get through; nor must the imaginative suggestion made immediately below equation (13) be altogether lost sight of.

There is, however, the possibility mentioned above that the relative specific inductive capacity of gold, K/K_0 , if a meaning can be attached to it, may be very large, perhaps (though very improbably, see Drude, *Wied. Ann.* vol. xxxix. p. 481) comparable with 1800. Suppose for a moment that it is equal to 1800; then the value of the critical quantity (7) is 1 and the value of α is

$$p \sqrt{\frac{1}{2} \mu K \times .4} = p \sqrt{\left(\frac{K}{5K_0}\right)} = \frac{2\pi \times 5 \times 10^{14}}{3 \times 10^{10}} \sqrt{360} \\ = 19 \times 10^5,$$

which reduces the calculated opacity considerably, though still not enough.

In general, calling $K/K_0 = c$, and writing the critical number $\frac{4\pi\mu v^2}{\sigma pc}$ as h/c , we have

$$\frac{2v^2}{p^2} \alpha^2 = \frac{1}{2} \alpha^2 / \beta^2 = \lambda^2 \alpha^2 / 2\pi^2 = \sqrt{(h^2 + c^2)} - c;$$

so that $a\lambda/2\pi$ ranges from $\sqrt{\frac{1}{2}h}$ when h/c is big, to $\frac{1}{2}h/\sqrt{c}$ when h/c is small.

Writing the critical number h/c as $\tan \epsilon$, the general value of α is given by

$$a\lambda = \pi \sqrt{2c(\sec \epsilon - 1)}. \quad \dots \quad (14)$$

This is the ratio of the wave-length in air to the damping distance in the material in general; meaning by "the damping distance" the thickness which reduces the amplitude in the ratio $e:1$. (14) represents expression (5); compare with (12').

Theory of a Film.

So far nothing has been said about the limitation of the medium in space, or the effect of a boundary, but quite recently Mr. Heaviside has called my attention to a special

theory, a sort of Fresnel-like theory, which he has given for infinitely thin films of finite conductance; it is of remarkable simplicity, and may give results more in accordance with experiment than the theory of the universal opaque medium without boundary, hitherto treated: a medium in which really the source is immersed.

Let a film, not so thick as gold-leaf, but as thin as the black spot of a soap-bubble, be interposed perpendicularly between source and receiver. I will quote from 'Electrical Papers,' vol. ii. p. 385:—"Let a plane wave $E_1 = \mu v H_1$ moving in a nonconducting dielectric strike flush an exceedingly thin sheet of metal [so thin as to escape the need for attending to internal reflexions, or the double boundary, or the behaviour inside]; let $E_2 = \mu v H_2$ be the transmitted wave out in the dielectric on the other side, and $E_3 = -\mu v H_3$ be the reflected wave*.

* *General Principles*.—It may be convenient to explain here the principles on which Mr. Heaviside arrives at his remarkably neat expression for a wave-front in an insulating medium,

$$E = \mu v H,$$

or as it may be more fully and vectorially written,

$$\nabla(\nu E) = \mu v H,$$

where \mathbf{E} is a vector representing the electric intensity (proportional to the electric displacement), \mathbf{H} is the magnetic intensity, and ν is unit normal to the wave-front. \mathbf{E} and \mathbf{H} are perpendicular vectors in the same plane, *i. e.* in the same phase, and $\mathbf{E} \mathbf{H} \nu$ are all at right angles to each other.

The general electromagnetic equations in an insulating medium are perhaps sufficiently well known to be, on Mr. Heaviside's system,

$$\text{curl } \mathbf{H} = K \dot{\mathbf{E}} \quad \text{and} \quad -\text{curl } \mathbf{E} = \mu \dot{\mathbf{H}},$$

where "curl" is the vector part of the operator ∇ , and where Maxwell's vector-potential and other complexities have been dispensed with.

[In case these equations are not familiar to students I interpolate a parenthetical explanation which may be utilised or skipped at pleasure.

The orthodox definition of Maxwell's name "curl" is that \mathbf{b} is called the curl of \mathbf{a} when the surface-integral of \mathbf{b} through an area is equal to the line-integral of \mathbf{a} round its boundary, \mathbf{a} being a vector or a component of a vector agreeing everywhere with the boundary in direction, and \mathbf{b} being a vector or component of vector everywhere normal to the area. Thus it is an operator appropriate to a pair of looped or interlocked circuits, such as the electric and the magnetic circuits always are. The first of the above fundamental equations represents the fact of electro-magnetism, specially as caused by displacement currents in an insulator, the second represents the fact of magneto-electricity, Faraday's magneto-electric induction, in any medium. Taking the second first, it states the fundamental law that the induced EMF in a boundary equals the rate of change in the lines of force passing through it; since the EMF or step of potential all round a contour is the line-integral of the electric intensity \mathbf{E} round it, so that

$$\text{EMF} = \int_{\text{cycle}} E ds = - \frac{dN}{dt} = - \iint \dot{B} dS = - \iint \mu \dot{H} dS;$$

“ At the sheet we have

$$\begin{aligned} E_1 + E_3 &= E_2 \\ H_1 + H_3 &= H_2 + 4\pi kzE_2, \end{aligned}$$

k being the conductivity of the sheet of thickness z . Therefore

$$\frac{E_2}{E_1} = \frac{H_2}{H_1} = \frac{E_1 + E_3}{E_1} = \frac{1}{1 + 2\pi\mu kzv}, \quad \dots \quad (15)$$

wherefore $-\mu\dot{H}$ equals the curl of E . (The statement of this second circuital law is entirely due to Mr. Heaviside; it is now largely adopted and greatly simplifies Maxwell's treatment, abolishing the need for vector potential.)

The first of the above two fundamental equations, on the other hand, depends on the fact that a current round a contour excites lines of magnetic force through the area bounded by it, and states the law that the total magnetomotive force, or line-integral of the magnetic intensity round the boundary, is equal to 4π times the total current through it; the total current being the “ampere-turns” of the practical Engineer.

Expressing this law in terms of current density c , we write

$$\text{MMF} = \int_{\text{cycle}} H ds = 4\pi C = \iint 4\pi c dS;$$

so always current-density represents the curl of the magnetic field due to it, or $\text{curl } H = 4\pi c$.

Now in a conductor $c = kE$, but in an insulator $c = \dot{D}$, the rate of change of displacement or Maxwell's “displacement-current”; and the displacement itself is proportional to the intensity of the electric field, $D = \frac{K}{4\pi} E$; hence the value of current density in general is

$$c = kE + \frac{K}{4\pi} \dot{E},$$

whence in general

$$\text{curl } H = 4\pi kE + K\dot{E} = (4\pi k + Kp)E,$$

and in an insulator the conductivity k is nothing.

The connexion between “curl” so defined and $V\nabla$ is explained as follows. The operator ∇ applied to a vector R whose components are $X \ Y \ Z$ gives

$$\left(i \frac{d}{dx} + j \frac{d}{dy} + k \frac{d}{dz} \right) (iX + jY + kZ),$$

which, worked out, yields two parts

$$S\nabla \text{ or } -\left(\frac{dX}{dx} + \frac{dY}{dy} + \frac{dZ}{dz} \right),$$

also called convergence, and

$$V\nabla \text{ or } i \left(\frac{dZ}{dy} - \frac{dY}{dz} \right) + j \left(\frac{dX}{dz} - \frac{dZ}{dx} \right) + k \left(\frac{dY}{dx} - \frac{dX}{dy} \right)$$

or say $i\xi + j\eta + k\zeta$, where $\xi \ \eta \ \zeta$ are the components of a spin-like vector ω . Now a theorem of Sir George Stokes shows that the normal component of ω integrated over any area is equal to the tangential component of R integrated all round its boundary; hence $V\nabla$ and curl are the same thing.

H is reflected positively and E negatively. A perfectly conducting barrier is a perfect reflector; it doubles the magnetic force and destroys the electric force on the side containing the incident wave, and transmits nothing."

[I must here interpolate a remark to the effect that though it can hardly be doubted that the above boundary conditions (tangential continuity of both E and H) are correct, yet in general we cannot avoid some form of æther-theory

Whenever ω is zero it follows that R has no circulation but is the derivative of an ordinary single-valued potential function, whose $dV = Xdx + Ydy + Zdz$. In electromagnetism this condition is by no means satisfied. \dot{E} and H or \dot{H} and E are both full of circulation, and their circuits are interlaced. Fluctuation in E by giving rise to current causes H; fluctuation in H causes induced E.]

Now differentiating only in a direction normal to a plane wave advancing along x , the operator $V\nabla$ becomes simply id/dx when applied to any vector *in* the wave-front, the scalar part of ∇ being nothing.

So the second of the above fundamental equations can be written

$$-i \frac{dE}{dx} = \mu \frac{dH}{dt},$$

or

$$\frac{dE}{dH} = \mu v;$$

so, ignoring any superposed constant fields of no radiation interest, E and H are vectors in the same phase at right angles to each other, and their tensors are given by $E = \mu v H$.

Similarly of course the other equation furnishes $H = KvE$; thus giving the ordinary $K\mu v^2 = 1$, and likewise the fact that the electric and magnetic energies per unit volume are equal, $\frac{1}{2}KE^2 = \frac{1}{2}\mu H^2$.

A wave travelling in the opposite direction will be indicated by $E = -\mu v H$; hence, as is well known, if either the electric or the magnetic disturbance is reversed in sign the direction of advance is reversed too.

(The readiest way to justify the equation $E = \mu v H$, *à posteriori*, is to assume the two well-known facts obtained above, viz. that the electric and magnetic energies are equal in a true advancing wave, and that $v = 1/\sqrt{\mu K}$; then it follows at once.)

Treatment of an insulating boundary.—At the boundary of a different medium without conductivity the tangential continuity of E and of H across the boundary gives us the equations

$$\begin{aligned} E_1 + E_3 &= E_2 \\ H_1 + H_3 &= H_2, \end{aligned}$$

where the suffix 1 refers to incident, the suffix 2 to transmitted, and the suffix 3 to reflected waves.

$H_1 + H_3$ may be replaced by $\mu v (E_1 - E_3)$, since the reflected wave is reversed; so we shall have, for the second of the continuity equations,

$$E_1 - E_3 = \frac{\mu_2 v_2}{\mu_1 v_1} E_2 = nm E_2;$$

when we have to lay down continuity conditions, and, according to the particular kind of æther-theory adopted so will the boundary conditions differ. My present object is to awaken a more general interest in the subject and to represent Mr. Heaviside's treatment of a simple case; but it must be understood that the continuity conditions appropriate to oblique incidence have been treated by other great mathematical physicists, notably by Drude, J. J. Thomson, and Larmor, also by Lord Rayleigh, and it would greatly enlarge the scope of this Address if I were to try to discuss the difficult and sometimes controversial questions which arise. I must be content to refer readers interested to the writings of the Physicists quoted—especially I may refer to J. J. Thomson's 'Recent Researches,' Arts. 352 to 409, and to Larmor, Phil. Trans, 1895, vol. 186, Art. 30, and other places.]

Now apply this to an example. Take k for gold, as we have done before, to be $1/2000 \mu$ seconds per square centim. and $v = 3 \times 10^{10}$ centim. per sec., for v is the velocity in the

n being the index of refraction, and m the relative inductivity. Hence, adding and subtracting,

$$\frac{E_2}{E_1} = \frac{2}{1+nm},$$

and

$$\frac{E_3}{E_1} = -\frac{1-nm}{1+nm};$$

well-known optical expressions for the transmitted and reflected amplitudes at perpendicular incidence, except that the possible magnetic property of a transparent medium is usually overlooked.

Treatment of a conducting boundary.—But now, if the medium on the other side of the boundary is a conductor instead of a dielectric, a term in one of the general equations must be modified; and, instead of curl $H = KpE$, we shall have, as the fundamental equation inside the medium,

$$-\frac{dH}{dx} = 4\pi kE;$$

or more generally $(4\pi k + Kp)E$.

So, on the far side of a thin slice of thickness z , the magnetic intensity H_2 is not equal to the intensity $H_1 + H_2$ on the near side, but is less by

$$dH = 4\pi kE dx = 4\pi kE_2 z = 4\pi k\mu v z H_2;$$

and this explains the second of the continuity equations immediately following in the text.

In a quite general case, where all the possibilities of conductivity and capacity &c. are introduced at once, the ratio of E/H is not μv or $(\mu/K)^{\frac{1}{2}}$, but is $(g + \mu p)^{\frac{1}{2}}(4\pi k + Kp)^{-\frac{1}{2}}$ for waves in a general material medium, (g may always be put zero), or $(R + pL)^{\frac{1}{2}}(Q + pS)^{-\frac{1}{2}}$ for waves guided by a resisting wire through a leaky dielectric.

The addition of dielectric capacity to conductivity in a film is therefore simple enough and results in an equation quoted in the text below.

dielectric not in the conductor; then take a film whose thickness z is one twenty-fifth of a wave-length of the incident light; and the ratio of the transmitted to the incident amplitude comes out

$$1/2\pi\mu kvz = \frac{1000}{\pi v z} = \frac{1}{200}.$$

Some measurements made by W. Wien at Berlin in 1888 (Wied. *Ann.* vol. xxxv.), with a bunsen-burner as source of radiation, give as the actual proportion of the transmitted to the long-wave incident light, for gold whose thickness is 10^{-5} centim., .0033 or $1/300$; while for gold one quarter as thick the proportion was 0.4 (see Appendix II. page 414).

He tried also two intermediate thicknesses, and though approximately the opacity increases with the square of the thickness, it really seems to increase more rapidly: as no doubt it ought, as the boundaries separate. However, for a thickness $\lambda/25$ I suppose we may assume that about $1/3rd$ of the light would be transmitted, whereas the film-theory

Simple treatment of the E.M. theory of light.—It is tempting to show how rapidly the two fundamental electromagnetic equations, in Mr. Heaviside's form, lead to the electromagnetic theory of light, if we attend specially to the direction normal to the plane of the two perpendicular vectors E and H , to the direction along say x , so that $\nabla = i d/dx$ and $\nabla^2 = -d^2/dx^2$.

In an insulating medium the equations are

$$\text{curl}H = K\dot{E} \quad \text{and} \quad -\text{curl}E = \mu\dot{H};$$

now $\text{curl} = V\nabla = \nabla$, since $S\nabla = 0$ in this case, so

$$\nabla^2 H = K\nabla\dot{E} = K\text{curl}\dot{E} = -K\mu\ddot{H};$$

or, in ordinary form,

$$\frac{d^2 H}{dx^2} = K\mu \frac{d^2 H}{dt^2},$$

and there are the waves.

If this is not rigorous, there is no difficulty in finding it done properly in other places. I believe it to be desirable to realize things simply as well.

In a conducting medium the fundamental equations are, one of them,

$$\text{curl}H = K\dot{E} + 4\pi kE = (Kp + 4\pi k)E,$$

while the other remains unchanged; unless we like to introduce the non-existent auxiliary g , which would make it

$$-\nabla E = (g + \mu p)H,$$

and would cover wires too.

$$\text{So} \quad -\nabla^2 H = (4\pi k + Kp)(g + \mu p)H,$$

the general wave equation. In all these equations p stands for d/dt ; but, for the special case of simply harmonic disturbance of frequency $p/2\pi$, of course ip can be substituted.

gives $(1/200)^2$; so even now a metal calculates out too opaque, though it is rather less hopelessly discrepant than it used to be. The result, we see, for the infinitely thin film, is independent of the frequency.

Specific inductive capacity has not been taken into account in the metal, but if it is it does not improve matters. It does not make much difference, unless very large, but what difference it does make is in the direction of increasing opacity. In a letter to me Mr. Heaviside gives for the opacity of a film of highly conducting dielectric

$$\frac{E_1}{E_2} = \left\{ (1 + 2\pi\mu kvz)^2 + \left(\frac{1}{2}mczp/v\right)^2 \right\}, \dots (16)$$

where I have replaced his $\frac{1}{2}\mu v z K p$ last term by an expression with the merely relative numbers K/K_0 and μ/μ_0 , called c and m respectively, thus making it easier to realise the magnitude of the term, or to calculate it numerically.

Theory of a Slab.

An ordinary piece of gold-leaf, however, cannot properly be treated as an infinitely thin film; it must be treated as a slab, and reflexions at its boundaries must be attended to. Take a slab between $x=0$ and $x=l$. The equations to be satisfied inside it are the simplified forms of the general fundamental ones

$$-\frac{dE}{dx} = \mu p H, \quad -\frac{dH}{dx} = 4\pi k E,$$

k being $1/\sigma$, and K being ignored; while outside, at $x=l$, the condition $E = \mu v H$ has to be satisfied, in order that a wave may emerge.

The following solutions do all this if $q^2 = 4\pi\mu k p$:—

$$E = A e^{qx} \left(1 + \frac{qv+p}{qv-p} e^{2q(l-x)} \right),$$

$$\mu v H = -\frac{A q v}{p} e^{qx} \left(1 - \frac{qv+p}{qv-p} e^{2q(l-x)} \right).$$

Conditions for the continuity of both E and H at $x=0$ suffice to determine A , namely if $E_1 H_1$ is the incident and $E_3 H_3$ the reflected wave on the entering side, while $E_0 H_0$ are the values just inside, obtained by putting $x=0$ in the above,

$$E_1 + E_3 = E_0,$$

$$E_1 - E_3 = \mu v (H_1 + H_3) = \mu v H_0.$$

Adding, we get a value for A in terms of the incident light E_1 ,

$$2E_1 p (qv - p) = A \{ (qv + p)^2 e^{2ql} - (qv - p)^2 \}.$$

whence we can write E anywhere in the slab,

$$\frac{E}{E_1} = \frac{2p(qv-p)}{(qv+p)^2 e^{2ql} - (qv-p)^2} \left\{ e^{qx} + \frac{qv+p}{qv-p} e^{2ql} e^{-qx} \right\}.$$

Put $x=l$, and call the emergent light E_2 ; then

$$\frac{E_2}{E_1} = \frac{4pqv}{(qv+p)^2 e^{ql} - (qv-p)^2 e^{-ql}} = \rho, \text{ say,} \quad (17)$$

and this constitutes the measure of the opacity of a slab, ρ^2 being the proportion of incident light transmitted.

It is not a simple expression, because of course p signifies the operator d/dt , and though it becomes simply ip for a simply harmonic disturbance, yet that leaves q complex. However, Mr. Heaviside has worked out a complete expression for ρ^2 , which is too long to quote (he will no doubt be publishing the whole thing himself before long), but for slabs of considerable opacity, in which therefore *multiple* reflexions may be neglected, the only important term is

$$\rho = \frac{4\sqrt{2} e^{-\alpha l} p/\alpha v}{1 + (1 + p/\alpha v)^2}, \quad \dots \dots \dots (18)$$

with

$$\alpha = \sqrt{(2\pi\mu p/\sigma)} = 3 \times 10^6$$

for light in gold; and

$$\frac{p}{\alpha v} = \frac{2\pi}{\alpha\lambda} = \frac{2\pi}{30 \times 5} = \frac{1}{25} \text{ about.}$$

So the effect of attending to reflexion at the walls of the slab is to still further diminish the amplitude that gets through, below the $e^{-\alpha l}$ appropriate to the unbounded medium, in the ratio of $\frac{2\sqrt{2}}{25}$, or about a ninth.

Effect of each Boundary.

It is interesting to apply Mr. Heaviside's theory to a study of what happens at the first boundary alone, independent of subsequent damping.

Inside the metal, by the two fundamental equations, we have

$$E_0 = \left(\frac{\mu p}{4\pi k}\right)^{\frac{1}{2}} H_0,$$

and by continuity across the boundary

$$E_1 + E_3 = E_0,$$

$$E_1 - E_3 = \mu v H_0 = \mu v E_0 \left(\frac{4\pi k}{\mu p}\right)^{\frac{1}{2}} = \frac{qv}{p} E_0,$$

where still $q^2 = 4\pi\mu kp$.

Therefore, for the transmitted amplitude

$$\frac{E_0}{E_1} = \frac{2p}{p + qv},$$

and for the reflected

$$\frac{E_3}{E_1} = \frac{p - qv}{p + qv},$$

or rationalising and writing amplitudes only, and understanding by p no longer d/dt in general, but only 2π times the frequency,

$$\frac{E_0}{E_1} = \frac{2p}{\sqrt{((p + \alpha v)^2 + \alpha^2 v^2)}} = \rho_1 \text{ say. . . (19)}$$

Any thickness of metal multiplies this by the factor $e^{-\alpha x}$, and then comes the second boundary, which, according to what has been done above, has a comparatively small but peculiar effect; for it ought to change the amplitude from ρ_1 into ρ , that is to give an emergent amplitude

$$\frac{4\sqrt{2} \cdot p/\alpha v}{1 + (1 + p/\alpha v)^2} E_1 e^{-\alpha l},$$

instead of the above incident on the second boundary

$$\frac{2p/\alpha v}{\sqrt{1 + (1 + p/\alpha v)^2}} E_1 e^{-\alpha l}; \quad . . . (20)$$

that is for the case of light in gold, for which $p/\alpha v$ is small, to change $2/\sqrt{2}$ into $2\sqrt{2}$, in other words, to double it.

The effect of the first boundary alone, ρ_1 , is $\frac{2\sqrt{2}\pi}{\alpha\lambda}$, or say $1/18$, and this is a greater reduction effect than that reckoned above for the two boundaries together.

Thus the obstructive effect of the two boundaries together comes out less than that of the first boundary alone—an apparently paradoxical result. About one-eighteenth of the light-amplitude gets through the first boundary, but about one-ninth gets through the whole slab (ignoring the geometrically progressive decrease due to the thickness, that is ignoring $e^{-\alpha l}$, and attending to the effect of the boundaries alone; which, however, cannot physically be done). At first sight this was a preposterous and ludicrous result. The second or outgoing boundary ejects from the medium nearly double the amplitude falling upon it from inside the conductor! But on writing this, in substance, to Mr. Heaviside he sent all the needful answer by next post. “The incident disturbance inside is not the whole disturbance inside.”

That explains the whole paradox—there is the reflected beam to be considered too. At the *entering* boundary the incident and reflected amplitudes are in opposite phase, and nearly equal, and their algebraic sum, which is transmitted, is small. At the *emerging* boundary the incident and reflected amplitudes are in the same phase, and nearly equal, and their algebraic sum, which is transmitted, is large—is nearly double either of them. But it is a curious action:—either more light is pushed out from the limiting boundary of a conductor than reaches it inside, or else, I suppose, the velocity of light inside the metal must be greater than it is outside, a result not contradicted by Kundt's refraction experiments, and suggested by most optical theories. It is worth writing out the slab theory a little more fully, to make sure there is no mistake, though the whole truth of the behaviour of bodies to light can hardly be reached without a comprehensive molecular dispersion theory. I do not think Mr. Heaviside has published his slab theory anywhere yet. A slab theory is worked out by Prof. J. J. Thomson in Proc. Roy. Soc. vol. xlv., but it has partly for its object the discrimination between Maxwell's and other rival theories, so it is not very simple. Lord Kelvin's Baltimore lectures probably contain a treatment of the matter. All that I am doing, or think it necessary to do in an Address, is to put in palatable form matter already to a few leaders likely to be more or less known: in some cases perhaps both known and objected to.

The optical fractions of Sir George Stokes, commonly written *b c e f*, are defined, as everyone knows, as follows. A ray falling upon a denser body with incident amplitude 1 yields a reflected amplitude *b* and a transmitted *c*. A ray falling upon the boundary of a rare body with incident amplitude 1 has an internally reflected amplitude *e* and an emergent *f*. General principles of reversibility show that $b + e = 0$, and that $b^2 + cf = 1$ in a transparent medium.

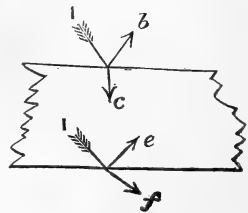

Now in our present case we are attending to perpendicular incidence only, and we are treating of a conducting slab; indeed, we propose to consider the obstructive power of the material of the slab so great that we need not suppose that any appreciable fraction of light reflected at the second surface returns to complicate matters at the first surface. This limitation by no means holds in Mr. Heaviside's complete theory, of course, but I am taking a simple case.

The characteristic number which governs the phenomenon is $\frac{p}{av}$ or $\frac{2\pi}{a\lambda}$, a number which for light and gold we reckoned as being about $\frac{1}{27}$, that is decidedly smaller than unity, a being $\sqrt{(2\pi\mu kp)}$ or $\sqrt{\left(\frac{2\pi\mu p}{\sigma}\right)}$. The characteristic number p/av we will for brevity write as h , and we will express amplitudes for perpendicular incidence only, as follows:—

Incident amplitude 1,

$$\text{externally reflected } b = - \left\{ \frac{1 + (1-h)^2}{1 + (1+h)^2} \right\}^{\frac{1}{2}}$$

$$\text{entering } c = \frac{2h}{\{1 + (1+h)^2\}^{\frac{1}{2}}},$$

Incident again 1,

$$\text{internally reflected } e = \left\{ \frac{1 + (1-h)^2}{1 + (1+h)^2} \right\}^{\frac{1}{2}},$$

$$\text{emergent } f = \frac{2\sqrt{2}}{\{1 + (1+h)^2\}^{\frac{1}{2}}}.$$

(It must be remembered that e and f refer to the second boundary *alone*, in accordance with the above diagram.)

Thus the amplitude transmitted by the whole slab, or rather by both surfaces together, ignoring the opacity of its material for a moment, is

$$\text{transmitted } cf = \frac{4\sqrt{2} \cdot h}{1 + (1+h)^2}.$$

To replace in this the effect of the opaque material, of thickness l , we have only to multiply by the appropriate exponential damper, so that the amplitude ultimately transmitted by the slab is

$$\frac{4\sqrt{2} \cdot p/av}{1 + (1 + p/av)^2} e^{-al}$$

times the amplitude originally incident on its front face.

This agrees with the expression (18) specifically obtained above for this case, but, once more I repeat, multiple reflexions have for simplicity been here ignored, and the medium has been taken as highly conducting or very opaque.

But even so the result is interesting, especially the result for f . To emphasize matters, we may take the extreme case when the medium is so opaque that h is nearly zero; then b is nearly -1 , c is nearly 0, being $h\sqrt{2}$, e is the same as b except for sign, and f is nearly 2.

An opaque slab transmits $8h^2e^{-2\alpha l}$ of the incident light energy; its first boundary transmits only $2nh^2$. The second or emergent boundary doubles the amplitude. Taken in connexion with the facts of selective absorption and the timing of molecules to vibrations of certain frequency, I think that this fact can hardly be without influence on the green transparency of gold-leaf.

APPENDIX I.

MR. HEAVISIDE'S *Note on Electrical Waves in Sea-Water*.

[Contributed to a discussion at the Physical Society in June 1897: see Mr. Whitehead's paper, *Phil. Mag.* August 1897.]

"To find the attenuation suffered by electrical waves through the conductance of sea-water, the first thing is to ascertain whether, at the frequency proposed, the conductance is paramount, or the permittance, or whether both must be counted.

"It is not necessary to investigate the problem for any particular form of circuit from which the waves proceed. The attenuating factor for plane waves, due to Maxwell, is sufficient. If its validity be questioned for circuits in general, then it is enough to take the case of a simply-periodic point source in a conducting dielectric ('*Electrical Papers*,' vol. ii. p. 422, § 29). The attenuating constant is the same, viz. (equation (199) *loc cit.*):—

$$n_1 = \frac{n}{v} \sqrt{\frac{1}{2}} \left[\left\{ 1 + \left(\frac{4\pi k}{cn} \right)^2 \right\}^{\frac{1}{2}} - 1 \right]^{\frac{1}{2}},$$

where $n/2\pi$ is the frequency, k the conductivity, c the permittivity, and $v = (\mu c)^{-\frac{1}{2}}$, μ being the inductivity.

"The attenuator is then $e^{-n_1 r}$ at distance r from the source, as in plane waves, disregarding variations due to natural spreading. It is thus proved for any circuit of moderate size compared with the wave-length, from which simply periodic waves spread.

"The formula must be used in general, with the best values of k and c procurable. But with long waves it is pretty certain that the conductance is sufficient to make $4\pi k/cn$ large. Say with common-salt-solution $k = (30^{11})^{-1}$, then

$$\frac{4\pi k}{cn} = \frac{2k\mu v^2}{f}$$

if f is the frequency. This is large unless f is large, whether we assume the specific c/c_0 to have the very large value 80 or the smaller value effectively concerned with light waves. We then reduce n_1 to

$$n_1 = (2n\mu k\pi)^{\frac{1}{2}} = 2\pi(\mu k f)^{\frac{1}{2}},$$

as in a pure conductor.

"This is practically true perhaps even with Hertzian waves, of which the attenuation has been measured in common-salt-solution by P. Zeeman. If then $k^{-1} = 30^{11}$ [and if the frequency is 300 per second] we get $n_1 = \text{about } \frac{1}{50000}$.

Phil. Mag. S. 5. Vol. 47. No. 287. April 1899. 2 F

“Therefore 50 metres is the distance in which the attenuation due to conductivity is in the ratio 2·718 to 1, and there is no reason why the conductivity of sea-water should interfere, if the value is like that assumed above.

“These formulæ and results were communicated by me to Prof. Ayrton at the beginning of last year, he having enquired regarding the matter, on behalf of Mr. Evershed I believe.

“The doubtful point was the conductivity. I had no data, but took the above k from a paper which had just reached me from Mr. Zeeman. Now Mr. Whitehead uses $k^{-1} = 20^{10}$, which is no less than 15 times as great. I presume there is good authority for this datum*. None is given. Using it we obtain $n_1 = \frac{1}{1316}$.

“Thus 50 metres is reduced to 13·16 metres. But a considerably greater conductivity is required before it can be accepted that the statements which have appeared in the press, that the failure of the experiments endeavouring to establish telegraphic communication with a light-ship from the sea-bottom was due to the conductance of the sea, are correct. It seems unlikely theoretically, and Mr. Stevenson has contradicted it (in ‘Nature’) from the practical point of view. So far as I know, no account has been published of these experiments, therefore there is no means of finding the cause of the failure.”

APPENDIX II.

The experiments of W. Wien on the transparency of metals, by means of a bolometer arranged to receive the radiation from a bunsen burner transmitted through different films, resulted in the following numbers for the proportion of radiation transmitted.

Metal.	Thickness in 10^{-7} centim.	Proportion transmitted.		Proportion reflected.
		Bunsen burner luminous.	Bunsen burner non-luminous.	
Platinum	20	·32	·37	·13
Iron & Platinum	40+20	·10	·14	·45
Gold 1	56	·040	·041	·63
Gold 2	100	·0035	·0036	·80
Gold 3	24	·41	·41	·05
Gold 4	35	·20	·20	·19
Silver 1 (blue) ...	36	·058	·046	·78
Silver 2 (grey) ...	39·5	·058	·055	·60
Silver 3 (grey) ...	29	·25	·42	·40
Silver 4 (blue) ...	59·7	·0022	·0019	·95
Silver 5 (grey) ...	27·3	·31	·43	·24

* Dr. J. L. Howard has recently set a student to determine the resistivity of the sea-water used by Professor Herdman, density 1·019 gr. per c.c., and he finds it to be 3×10^{10} c.g.s. at 15° C.—O. J. L., March 1899.

The thickness is in millionths of a millimetre, *i. e.* is in terms of the milli-microm called by microscopists $\mu\mu$.

The films were on glass, and the absorption of the glass was allowed for by control experiments.

It is to be understood that of the whole incident light the proportion reflected is first subtracted, and the residue is then called 1 in order to reckon the fraction transmitted of that which enters the metal, it being understood that the residue which is not transmitted (say .68 or .63 in the case of platinum) is absorbed. It may be that more and better work has been done on the opacity of metals than this: at any rate there seems to me room for it. I do not quote these figures with a strong feeling of confidence in their accuracy. They are to be found in Wied. *Ann.* vol. xxxv. p. 57.

XXXVI. Note on Mr. Sutherland's Paper on the Cathode Rays.

To the Editors of the Philosophical Magazine.

GENTLEMEN,

IN the March number of the *Philosophical Magazine* Mr. Sutherland considers a theory of the cathode rays, which I published in this Journal in October 1897, and in which the carriers of the charges were supposed to be the small corpuscles of which the atoms of the elementary bodies could, on an extension of Prout's hypothesis, be supposed to be built up. Mr. Sutherland takes the view that in the cathode rays we have disembodied electric charges, charges without matter—electrons—their apparent mass being due to the energy due to the magnetic force in the field around them varying as the square of the velocity (see *Phil. Mag.* xl. p. 229). I may say that the view that in the cathode rays the constancy of the mass arose from the charge being torn away from the atom, so that we had only the effective mass due to charge, occurred to me early in my experiments, but except in the form (which I gather Mr. Sutherland does not adopt), and which only differs verbally from the view I took, that the atoms are themselves a collection of electrons, that is, constitute an assemblage of particles the individuals of which are the same as the carriers in the cathode rays; this conception seemed to me to be wanting in clearness and precision, and beset with difficulties from which the other was free. In the theory which I gather Mr. Sutherland holds of the cathode rays, we have atoms which are comparatively large systems; these can be charged with electricity, of which in electrons and neutrons we have what correspond to atoms and molecules, the radius of an electron being about 10^{-14} cm. What conception must we form of the connexion between the

above and the electron when the atom is charged? The charged atom cannot behave as if the charge were spread over its surface; for if it did it would require a potential fall of about a million volts to separate the electron from the atom. Again, the value of m/e as determined by the Zeeman effect is of the same order as that deduced from the deflexion of the cathode rays, so that the charge must move independently of the body charged. The electron thus appears to act as a satellite to the atom.

A difficulty in the way of supposing that mass is entirely an electrical effect, and that in the impact of cathode rays we have electrons striking against much larger masses, is the large proportion of the energy converted into heat when the cathode rays strike against a solid. When an electron is stopped, theory shows that the energy travels off in a pulse of electromagnetic disturbance, and this energy would only appear as heat at the place struck if the waves were absorbed by the target close to the point of impact; if these targets were made of a substance like aluminium, which is transparent to these waves, we should expect much of the energy to escape in the pulse. As far as I can see the only advantage of the electron view is that it avoids the necessity of supposing the atoms to be split up: it has the disadvantage that to explain any property of the cathode rays such as Lenard's law of absorption, which follows directly from the other view, hypothesis after hypothesis has to be made: it supposes that a charge of electricity can exist apart from matter, of which there is as little direct evidence as of the divisibility of the atom; and it leads to the view that cathode rays can be produced without the interposition of matter at all by splitting up neutrons into electrons: it has no advantage over the other view in explaining the penetration of solids by the rays, this on both views is due to the smallness of the particles. Until we know something about the vibrations of electrons, it does not seem to throw much light on Röntgen rays to say that these are vibrations of the electrons.

The direct experimental investigation of the chemical nature (so to speak) of the cathode rays is very difficult, and though I have for some time past been engaged on experiments with this object, they have not so far given any decisive result.

Yours very sincerely,
J. J. THOMSON.

Cavendish Laboratory, Cambridge,
March 11th, 1899.

XXXVII. *Notices respecting New Books.*

HARPER'S SCIENTIFIC MEMOIRS. *Edited by Dr. J. S. AMES, Professor of Physics in Johns Hopkins University, Baltimore.*—I. *The Free Expansion of Gases*; Memoirs by Gay-Lussac, Joule, and Joule and Thomson.—II. *Prismatic and Diffraction Spectra*; Memoirs by J. von Fraunhofer. New York & London: Harper & Bros., 1898.

THESE two volumes form the commencement of a series of memoirs on different branches of physics, each containing the more important epoch-making papers in connexion with the subject of the memoir. Professor Ames, in addition to editing the series, contributes the translations of the papers by Gay-Lussac and Fraunhofer in the first and second volume respectively, and in subsequent volumes such subjects as "The Second Law of Thermodynamics," "Solutions," "The Laws of Gases," and "Röntgen Rays" will, among others, receive similar treatment. Each paper will be enriched by notes and references, and the bibliography of the subject will be given in an appendix to each volume.

The series will serve to bring before English-speaking readers the principal foreign classical papers on physical subjects, and the reprinting of the papers published in the numerous and frequently inaccessible journals issued in this country should prove a great convenience. The list of American physicists who have undertaken a share of the editing is a guarantee that the work will be done with the characteristic industry of our friends across the Atlantic.

J. L. H.

XXXVIII. *Proceedings of Learned Societies.*

GEOLOGICAL SOCIETY.

[Continued from p. 328.]

December 7th (*cont.*)—W. Whitaker, B.A., F.R.S., President, in the Chair.

2. 'The Permian Conglomerates of the Lower Severn Basin.' By W. Wickham King, Esq., F.G.S.

The rocks thus described are the calcareous conglomerates included in the Middle Permian of the Shropshire type, and exposed north of the Abberley and Lickey Hills. Three calcareous horizons occur, interstratified in sandstones or marls and surmounted by the Permian breccia. It was the opinion of Ramsay and others that the materials of the calcareous horizons and of the Permian breccia had been brought from the Welsh border; but Buckland and

Jukes, among others, claimed a southern derivation for those of the Permian breccia, from local hill-ranges to the south. The latter view accords with the fact that the pebbles composing these calcareous horizons, and also the broken fragments constituting the Permian breccias north of the Abberley and Lickey Hills, are coarser in the south-easterly direction, and gradually become finer to the north-west.

The fragments embedded in the Middle Permian calcareous bands near the Lickey are chiefly of Archæan rocks, but in all the other districts described there are very few rock-fragments older than Woolhope Limestone. On the other hand, pebbles of dolomitic Wenlock and Carboniferous Limestones are abundant, while Aymestry Limestone, Old Red, Carboniferous, and Lower Permian sandstones occur in greater or less abundance; and all these rocks, except the Carboniferous Limestone, may be seen *in situ* near at hand to the south. A summary of work done in the Halesowen Coal-Measure conglomerates and in the Permian breccia north of the Abberley and Lickey Hills is given, to bring out one of the lines of argument adopted.

(1) Ridges near the Lickey were denuded down to the Archæan rocks in Upper Carboniferous time; therefore, as might have been expected, both the adjacent Upper Carboniferous conglomerate and the Middle Permian calcareous conglomerates are composed of such fragments of Archæan rocks as are to be found *in situ* there, or at Nuneaton; and the Upper Carboniferous conglomerate is also largely composed of Palæozoic rocks identical with those *in situ* on the flanks of the Lickey.

(2) The Middle Permian calcareous conglomerates of the other districts described are for the most part made up of fragments not older than the Woolhope Limestone, which were presumably derived by denudation from ridges which had become more extensive.

(3) The Lickey ridges having been denuded to the Archæan rocks and the more extended area to the Woolhope Limestone, the later Permian breccias are composed of Archæan fragments near the Lickey, but of rocks not newer than the Woolhope Limestone in the other districts north of the Abberley and Lickey Hills.

The author has for several years called the ancient ridges from which these materials were derived the 'Mercian Highlands,' and claims that the Palæozoic and Archæan rocks composing the stumps of these highlands lie almost entirely buried under the Trias of the Midlands south and east of the S.E. Shropshire and South Staffordshire regions.

December 21st.—W. Whitaker, B.A., F.R.S., President,
in the Chair.

The following communications were read:—

1. "On a Megalosauroid Jaw from Rhætic Beds near Bridgend, Glamorganshire." By E. T. Newton, Esq., F.R.S., F.G.S.

2. 'The Torsion-Structure of the Dolomites.' By Maria M. Ogilvie, D.Sc. [Mrs. Gordon].

The paper opens with a general account of the work of Richthofen, Mojsisovics, Rothpletz, Salomon, Brögger, the author, and others on the Dolomitic area of Southern Tyrol. It then gives the results of a detailed survey recently made by the author of the complicated stratigraphy of the rocks of the Gröden Pass, the Buchenstein Valley, and the massives of Sella and Sett Sass; together with the author's interpretation of these results, and her application of that interpretation to the explanation of the Dolomite region in general. The author concludes that overthrusts and faults of all types are far more common in the Dolomites than has hitherto been supposed. The arrangement of these faults is typically a torsion-phenomenon, the result of the superposition of a later upon an earlier strike. This later crust-movement was of Middle Tertiary age, and one with the movement which gave origin to the well-known Judicarian-Asta phenomena. The youngest dykes (and also the granite-masses) are of Middle Tertiary age, while the geographical position of both is the natural effect of the crust-torsion itself. This crust-torsion also fully explains the peculiar stratigraphical phenomena in the Dolomite region, such as the present isolation of the mountain-massives of dolomitic rock.

The Gröden Pass area, first selected for description by the author, is a distorted anticlinal form running approximately N.N.E. and S.S.W., and including all the formations ranging from the *Bellerophon*-Limestone, through the Alpine Muschelkalk and Buchenstein Beds, to the top of the Wengen Series. When studied in section, the strata of the Pass are found to be arranged in a complex fold form, showing a central anticlinal with lateral wings, limited on opposite sides by faults and flexures. Strongly marked overthrusting to S.S.E. in the northern wing is responded to by return overthrusts to N.N.W. in the southern wing. The strata in the middle limb of the anticlinal wings bend steeply downwards into knee-bend flexures. Through these run series of normal and reversed faults, into which has been injected a network of igneous rocks, giving rise to 'shear-and-contact' breccias, which have previously been grouped as Buchenstein tuff and agglomerates, and referred to the Triassic period.

The area of movement of the Gröden Pass system is an ellipsoid in form. Two foci occur within it, where the effects of shear and strain have culminated. The forces of compression acted not in parallel lines, but round the area, thus causing torsion of the earth-crust. Two main faults occur (with a general east-and-west trend) whose actual lines of direction intersect at a point about midway between the foci of the torsion-ellipsoid. These are the chief strike torsion-faults; many minor ones pass out easterly and westerly from the foci, forming longitudinal or strike torsion-bundles. The strike system of faults is cut by a series of diagonal or transverse curved branching faults, with a more or less north-easterly or north-westerly direction. These diagonal faults may cut each other, or

may combine to form characteristic torsion-curves. The author regards the longitudinal and diagonal faults as constituting one system. Each portion on one side of the anticlinal form of the system has its reciprocal on the other side. The Spitz Kofl syncline on the north is the reciprocal of that of Sella on the south, the Langkofl on the south-west of that of Sass Songe on the north-east, and so on.

The anticlinal area of the Buchenstein Valley is next described. Here we have a torsion-system similar to that of the Gröden Pass, and made up of similar elements; but the western portion of the anticlinal is much compressed and displaced. Opposing areas of depression are also found here, that of Sella and Sett Sass on the north being reciprocated by that of the Marmolata on the south, and so on. The porphyrite-sills have here been mainly injected into the knee-bends of the northern wing of the anticlinal form, but igneous injections and contact-phenomena are also met with in some of the transverse faults.

A full description is given of the sequence and stratigraphy in the Sella massive—once regarded by some authorities as a Triassic coral-reef. This is an ellipsoidal synclinal area with N.N.E. and S.S.W. axes twisted to north-east and south-west. Peripheral overthrusts have taken place outward from the massive, in such a way as to buckle up the rocks like a broad-topped fan-structure, and these overthrusts are traced by the author completely round the massive. A central infold of Jurassic strata occurs on the plateau, where the Upper Trias has been overthrust inwards on three sides of the infold. The author next passes in review the results obtained in the area of Sett Sass, etc. and shows how they all present corresponding tectonic phenomena.

The district thus studied in detail by the author forms a typical unit in the structural features of the Dolomite region. It is cut off to the eastward by the limiting fault (north-and-south of Sasso de Stria, and to the westward by the parallel fault of Sella Joch. These are definite confines, which limit a four-sided area, influenced by the Gröden Pass torsion-system on the north and the Buchenstein Valley system on the south. The limits of this four-sided figure include a compound area of depression (formed by the Sella and Sett Sass synclinals) traversed by the diagonal Campolungo buckle. 'The area displays in a marked degree the phenomena of interference cross-faults cutting a series of peripheral overthrusts round the synclines, and parallel flexure-faults between the anticlinal buckles and the synclinal axes.'

In conclusion, the author applies her results to the interpretation of the complexities of the Judicarian-Asta region of the Dolomites in general, and also to the explanation of the characteristic structural forms of the Alpine system as a whole.

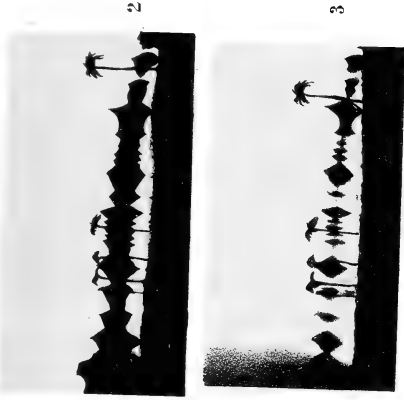

Fig. 6.

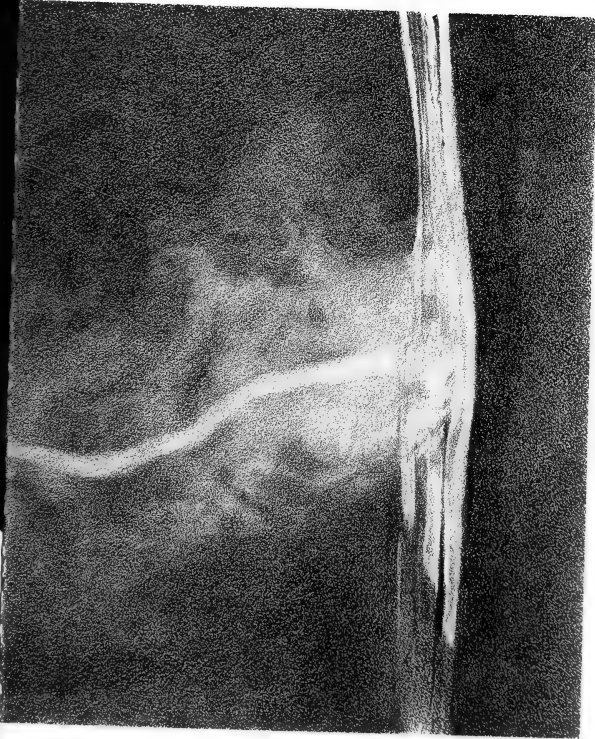

Fig. 7.

Mintern, Eros lith.

Fig 1



Fig 2

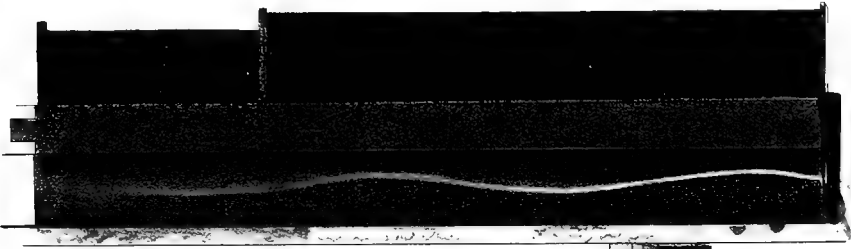

Fig 3

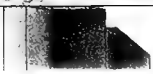

Fig 4

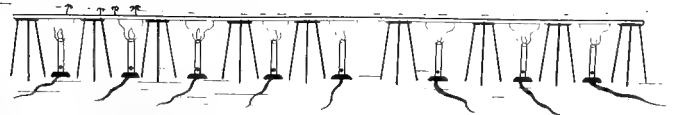
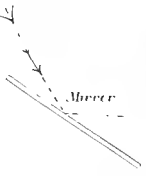

Fig 5

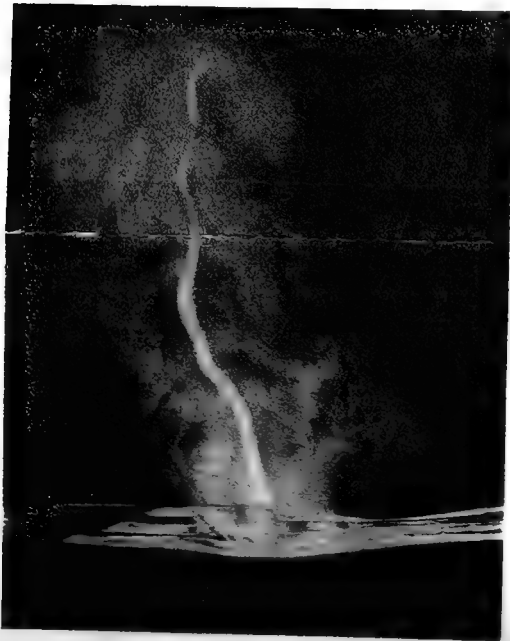
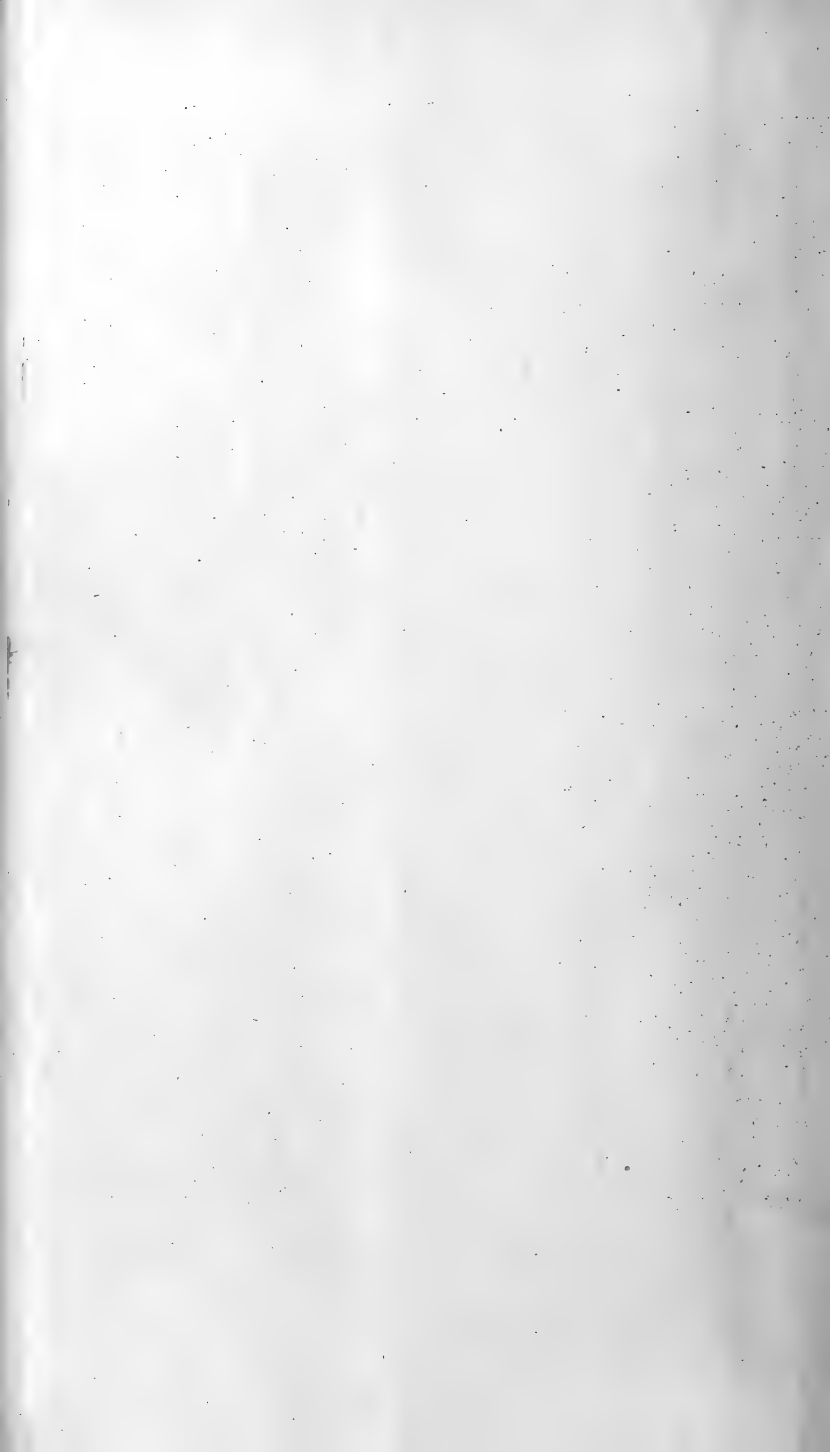

Fig. 7.



Fig. 6



THE
LONDON, EDINBURGH, AND DUBLIN
PHILOSOPHICAL MAGAZINE
AND
JOURNAL OF SCIENCE.

[FIFTH SERIES.]

MAY 1899.

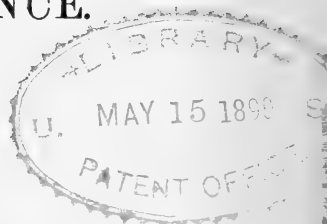

XXXIX. *The Effects of Temperature and of Circular Magnetization on Longitudinally Magnetized Iron Wire.* By F. H. PITCHER, M.A.Sc., *Demonstrator in Physics, McGill University, Montreal* *.

Objects of the Investigation.

IN commencing these experiments in October 1894, the original intention was to investigate only the effect of temperature on the magnetization of iron. With this object the specimen was heated in a platinum tube, maintained at a steady temperature by means of an electric current. The temperature was inferred from the resistance of the platinum tube, which was very uniformly heated and extended for some distance beyond the ends of the iron wire. This proved to be a very perfect method of heating, as the temperature could be easily varied and accurately regulated and measured. The current in the platinum tube was also without magnetic effect on the specimen or the magnetometer, and the specimen was necessarily at the same mean temperature as the enclosing tube. A concentric brass tube formed the return lead.

Unfortunately there was some difficulty at the outset in procuring suitable platinum tubes, and the attempt to make tubes in the laboratory by rolling up strips of platinum foil did not prove entirely satisfactory owing to the inferior quality of the foil. The tubes invariably cracked and became useless before a complete series of observations had been

* Communicated by Prof. H. L. Callendar, M.A., F.R.S.

obtained. The incomplete series of tests obtained in this manner were, however, of interest as a verification of the method subsequently adopted.

In the meantime, while awaiting the production of suitable tubes, it was thought that interesting results might be obtained by heating the iron wire with an electric current passed through the wire itself, and deducing its mean temperature from its resistance, with the aid of the formula verified by Prof. Callendar (*Phil. Trans.*, A. 1887, p. 225) by the direct comparison of platinum and iron wires. The objection to this method of heating is that the wire is circularly magnetized by the heating current, and that it is necessary to disentangle the effects of the temperature change and of the circular magnetization on the longitudinal magnetization of the specimen. The effect of the circular field itself, however, is not without interest.

In order to disentangle these effects, three separate series of observations were taken for the same range of current or circular field, (1) in a very high vacuum; (2) in air at atmospheric pressure; (3) in a current of water. In case (1) a current of 16 amperes sufficed to heat the wire above its critical temperature; in case (2) the highest temperature was 400° C.; in case (3) the heating effect was practically negligible.

Methods of Measurement Adopted.

The iron wire specimen was magnetized by means of a specially constructed solenoid, and the intensity of magnetization I at any time was observed by means of the deflexion of a magnetometer, the direct effect of the solenoid being very carefully compensated by means of a balancing coil in the usual manner. The broadside-on position was adopted for the test in preference to the vertical or the end-on position, as it had been found by preliminary tests that, if the distance of the specimen from the magnetometer were suitably adjusted, the broadside-on method agreed much more closely with ballistic tests of the same specimen than either of the more usual positions. The value of the Earth's field H was repeatedly determined by the aid of a Kohlrausch variometer.

The deflexion of the magnetometer was observed by means of a telescope and a metre-scale of milk-glass very accurately divided. The magnetometer was also provided with suitable galvanometer-coils, so that readings of current and resistance could be taken on the same scale. The scale of the galvanometer was carefully calibrated throughout, and all the

observations were reduced by means of the correction curve obtained. The heating and magnetizing currents were passed through suitable manganin resistances immersed in oil, so that by observing the deflexion of the galvanometer when connected successively to the terminals of the manganin resistances and the specimen itself, the two currents and the resistance of the specimen could be quickly determined at any time with an accuracy of at least 1 part in 1000. By varying the resistance in series with the galvanometer it was possible to obtain accurately readable deflexions through a very wide range of current and resistance.

The Magnetizing Solenoid.—The solenoid was wound on a thin brass tube about 70 centim. long, with an external diameter of 2.23 centim. The insulation resistance was very high, special pains having been taken to insulate each layer with paraffin and paper. The winding was tested for uniformity by measuring each fifty turns during the process. The length of the winding was 60.25 centim., containing 4079 turns of No. 24 B & S double silk-covered wire in four layers, and having a resistance of 28 ohms at 15° C. This gave a magnetizing field of over 300 c.g.s. with 100 volts on the terminals. In order to dissipate the heat due to the magnetizing current at high fields, an internal water circulation was provided through an annular space formed by a second concentric brass tube.

The Mounting for the Iron Wire Specimen.—As the specimen was enclosed in a vacuum-tube, and its resistance at each temperature determined, a special form of mounting was necessary.

The iron-wire specimen was 0.127 centim. diameter and 26.1 centim. long, or a little over 200 diameters. Its ends were fused to copper wires .040 centim. diameter and 10 centim. long; the diameter of the copper wire being chosen by trial to give a uniform temperature throughout the whole length of the iron wire when the heating current was passed through the circuit.

The ends of these copper wires were tin-soldered and riveted to stout copper conductors which were brought out through spiral copper springs to the ends of the containing tube. The two copper springs, whose function was to take up the slack of the heated specimen, had each exactly the same number of turns, and were wound oppositely so that the direct effect (on the magnetometer) of the current circulating through them would be compensated. The whole was centered and kept in place by brass washers which fitted the thin glass containing tube. The glass tube just fitted the inner brass

tube, and was made sufficiently long to extend at both ends beyond the brass tube.

Very fine platinum wires (0.003 centim. diameter) were attached at 15 centim. apart to the iron wire specimen. They served as potential leads, and were brought out beyond one end of the glass containing tube, through sealed capillary tubes.

The glass tube was made tight at both ends by fitting brass cups over and filling with fusible alloy, one end of the tube having been drawn down so that when capped it could be slipped into the solenoid tube. A copper tube was introduced through and soldered in the larger brass cap, to serve for exhausting. The vacuum was maintained by a five-fall Sprengel pump, assisted in the early stages by a water pump.

The remaining apparatus consisted mainly of resistance-boxes, rheostats, special arrangements of mercury-cup contacts, switches, storage-batteries, &c.

Preliminary Tests.

The specimen was of commercial so-called soft iron wire, and was carefully annealed and polished before mounting. The vacuum-tube containing it was connected to the Sprengel pump and a high vacuum maintained while the wire was being heated by the current. It was observed by the eye that the heating was very uniform, the whole becoming an even red right up to the ends, at a high vacuum. The zero-point or resistance at 0° C. of the specimen was now obtained. It was then placed in the solenoid and the equivalent magnetic length determined. This was found to be a little over 20 centim., and the magnetometer distance was arranged so that slight changes of the length had a minimum effect on the magnetometer readings. A preliminary test for the magnetic quality of the iron at ordinary temperatures was first made. It was found before further annealing to be fairly hard, having a hysteresis loss for $B=17,000$, of 16,000 ergs per cub. centim., and a permeability at that induction of 500.

After annealing several times in a vacuum, the loss at nearly the same induction had fallen to 6000 ergs, and finally, after successive annealings, arrived at the extraordinarily low value of 557 ergs for $B=3500$ at ordinary temperatures. This, in spite of the fact that the specimen was only commercial wire, is almost as good as the best specimen of transformer iron tested by Ewing. By this time the wire had settled down to a very steady magnetic state, as shown

by successive tests before and after heating. Before proceeding further the zero-point of the specimen was again tested, and was found to agree to within 1/10 of one per cent. with the previous determination. There was no trace of oxidation.

The Observations.

The method of taking the observations was as follows:—First, the containing tube was exhausted. The magnetometer deflexions were observed at longitudinal fields ranging from 1 to 30, with currents in the wire varying from 0 to 16 amp. It was previously observed that the wire was practically demagnetized at 16 amps., which corresponds to a temperature of 750° C.

The current in the solenoid was reversed several times before each reading of the magnetometer deflexion, thus ensuring a reversal curve. The current in the wire was kept constant for each reversal curve. Its value with that of the corresponding resistance of the wire was observed at intervals along the curve. The effect of residual thermal currents in the heating circuit was eliminated by reversal of the current in the wire.

The Sprengel pump was kept running during the whole set of observations in order that the gases given off from the heated iron and copper, as well as air which might leak in owing to imperfect sealing, might not affect the vacuum. Under these conditions the vacuum was kept very high and constant, and the iron wire remained bright throughout the whole series of tests.

On the completion of this set of observations the vacuum was let down, the containing tube disconnected from the pump, and a similar set taken in air. All the conditions remained the same as before, except that the wire was tested in air instead of in a high vacuum, and was therefore at a necessarily lower temperature for the same heating current.

As soon as possible afterwards, two similar series of observations were taken at much higher fields, varying from 50 to 300. The conditions were exactly the same in this case as in the lower fields, except that the controlling field of the magnetometer had to be strengthened, and that the vacuum at which the higher temperature observations were taken was slightly less perfect.

At this stage the zero-point of the specimen was again tested and was found to agree with the two previous determinations, within the limits of accuracy of the method. It is interesting to observe that the electrical resistance was

practically unaffected by magnetization, and that the reduction of the hysteresis loss to one-third of its original value was unaccompanied by any measurable change of conductivity.

Specimen tables of the reduced observations in vacuum and in air are here exhibited.

TABLE I.—Longitudinal Fields 1–30.

In Vacuum.		In Air.	
Current in Wire 12.45 amp. Resistance of Wire 0.08324 ω . Temperature of Wire 552° C.		Current in Wire 12.60 amp. Resistance of Wire 0.03447 ω . Temperature of Wire 224° C.	
I.	H.	I.	H.
43.4	0.99	20.8	0.99
67.3	1.45	42.7	1.45
86.1	1.78	58.8	1.75
108.4	2.24	82.0	2.23
135.0	2.75	108.0	2.75
173.5	3.60	147.0	3.59
286.1	6.27	269.0	6.27
437.6	10.10	432.5	10.08
963.0	30.30	1003.0	30.25

TABLE II.—Longitudinal Fields 50–290.

In Vacuum.		In Air.	
Current in Wire 12 amp. Resistance of Wire 0.07312 ω . Temperature of Wire 496° C.		Current in Wire 11.60 amp. Resistance of Wire 0.03035 ω . Temperature of Wire 187° C.	
I.	H.	I.	H.
1235	51.2	1254	51.2
1359	93.9	1410	93.9
1397	167.9	1528	167.0
1437	290.4	1633	290.3

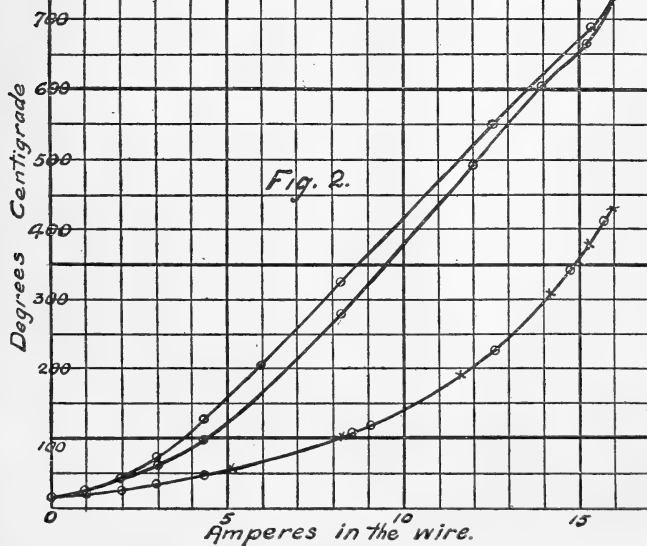
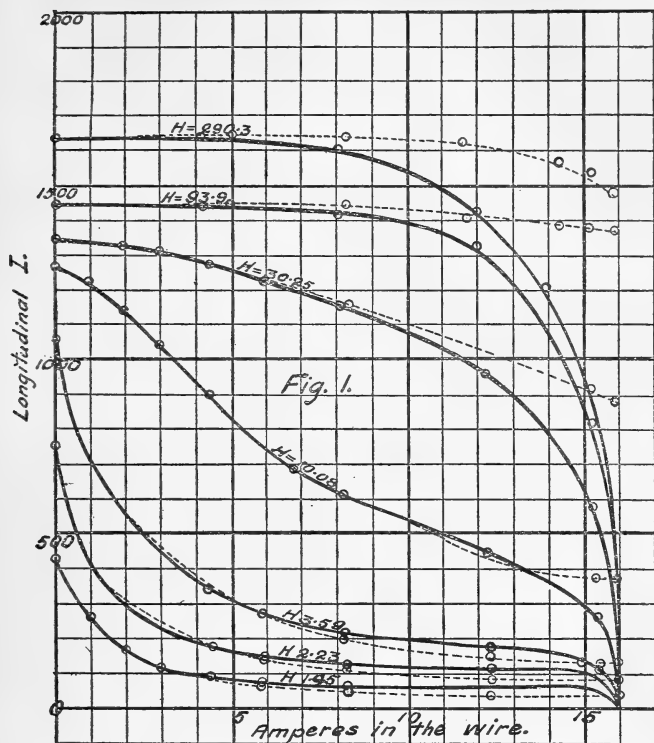

Figs. 1 and 2. Containing Results of Direct Observation.

The Curves of fig. 1.—The magnetic observations were taken at thirteen different fields, curves for seven of which have been plotted in fig. 1. The longitudinal field of the solenoid is indicated for each pair of curves. Each pair is drawn for the same field. Abscissæ represent current in the wire and ordinates longitudinal intensity of magnetization. The curves drawn in full lines are for the observations taken in a vacuum and at a higher temperature than those in dotted lines, which are for the observations taken in air. Where the curves coincide, showing no effect of temperature, full lines are drawn.

The curves shown in fig. 2 are the corresponding temperature-curves plotted to current in the wire. The lower of these curves is that for the specimen in air. The points marked with a cross belong to the observations in fields above 30 c.g.s. The middle curve is the temperature-curve in vacuum for the higher fields; while the top curve is that for lower fields in vacuum, from 30 down. The temperature-difference between the dotted and full-line curves for any current in the wire can at once be found by consulting the corresponding temperature-curves in fig. 2 on the same ordinate.

Considering the tables and the curves of figs. 1 and 2, it will be noticed that the known behaviour of soft iron at constant fields, as temperature advances, is well displayed.

In high fields the dotted and full-line curves of each pair separate almost from the start, and do not meet in any part of their course, showing a continual decrease in intensity of magnetization from the beginning as temperature increases.

At a field of 10 c.g.s. there appears to be no change in the intensity of magnetization for a temperature-difference of 350° C., as shown by the fourth curve (fig. 1) from the top, together with the top and bottom curves (fig. 2).

At still lower fields the intensity begins to increase for a comparatively small temperature-difference, as shown by the two lower pairs of curves, fig. 1. The effect of the circular field on the longitudinal component is here very marked. If the dotted curves, where the temperature is less in evidence, be considered, it will be seen that, in high longitudinal fields, as the circular field increases there is but little change in the longitudinal intensity. Somewhere between a longitudinal field of 30 and 10 a point of inflection occurs, and the curves below are changed in form entirely. At fairly low fields (from 3.5 downwards) the drop with small increments of circular field is at first very great, but soon reaches a limit; and the curves become very flat.

The explanation of these effects is that for high longitudinal

fields the permeability is very small. Therefore the circular field would have at first only a slight effect in diminishing the longitudinal intensity. On the other hand, in lower fields the permeability is many times greater, and hence the effect of the circular field is much more marked, until the direction of the resultant field swings around nearer to the direction of the circular field, when the rate of change in the longitudinal intensity becomes very slow.

Temperature-Curves, fig. 2.—The curious wave which occurs at the upper end of each high-temperature curve (*in vacuo*) may be partly due to the sudden change in the temperature-coefficient of iron at high temperatures*, and partly also, in this particular case, to the effect on the vacuum of gas given off from the wire. The pump may not have been able to exhaust at a sufficiently high rate.

Hopkinson (Phil. Trans. vol. clxxx.) investigated the resistance-temperature curves of soft iron and steel at high temperatures up to 900° C. The temperature was inferred from the resistance of a copper wire enclosed with his specimens, apparently on the assumption of a constant temperature-coefficient for copper. He found a sudden drop in the temperature-coefficient for soft iron and steel between 800° and 900° C. beyond the critical point. It seems desirable that this should be tested up to higher temperatures by comparison with a platinum pyrometer.

Method of Distinguishing the Effects of Temperature and of Circular Magnetization.

By treating the ordinates of the curves in fig. 1 as one component of the *resultant* intensity the temperature-variation of the magnetization of iron at high fields can be worked out to a fairly accurate result.

The first step in the reduction was to obtain a family of curves (*a*) of average resultant *I* and *H* at different temperatures. These were compared with a similar set (*b*) from which temperature-effect had been eliminated. Then by treating the drop between corresponding curves of the first and second set—at the same resultant fields—as due to temperature, the temperature-effect on the resultant intensity was obtained.

The average circular field in the wire was taken equal to two thirds of the field at the periphery. This was compounded with the longitudinal field to give the average resultant field due to the two magnetizing forces. The longitudinal field previous to compounding was corrected for the effect of the

* A rapid increase of a similar character was observed by Callendar to occur just below the critical point.

ends of the specimen. The corresponding value of the average resultant permeability was taken from the full-line curves (fig. 1).

Effect of Circular Magnetization (fig. 3).

Before obtaining the second set (*b*) of average resultant *I* and *H* curves with which the above were compared, it was necessary to eliminate the effect of temperature. This was done by taking the drop between any two points on the dotted and full-line curves (fig. 1) which are at the same temperature as due to circular magnetization, an assumption which is very nearly correct, especially in the higher fields.

In this way the family of curves in fig. 3 was obtained.

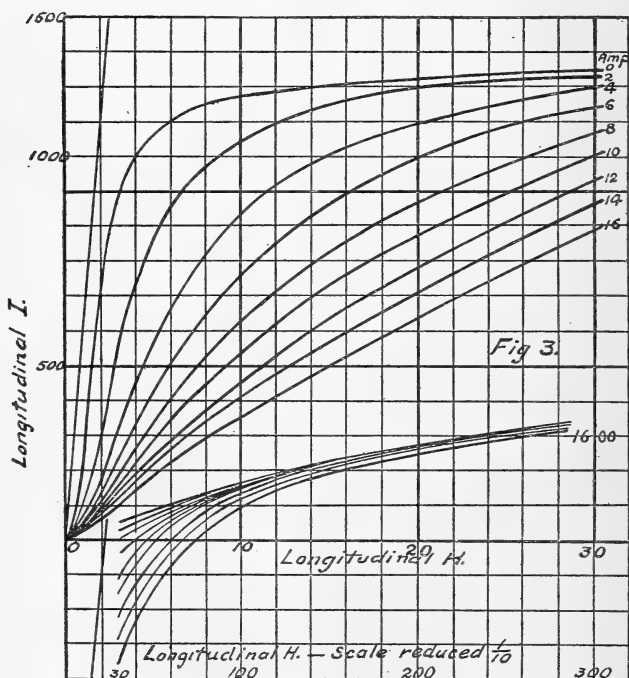

Effect of Circular Field at Constant Temperature 18° C. on the *I-H* Curves of Longitudinal Magnetization.

The ordinates are *longitudinal* magnetization, and the abscissæ longitudinal field. The curves in the lower part of the figure are the continuation in higher fields of those above. They are plotted to the same scale of *I*, but the *H* scale is reduced

ten times. The curves are all drawn for the same temperature, viz. 18° C., and the current in the wire is indicated in each case. The correction-line for the length of the specimen is also drawn.

Method of Deducing the Temperature-Curves (fig. 4).

By compounding the ordinates of the curves in fig. 3 with the corresponding value of the average circular intensity, the set of resultant I and H curves (*b*) at constant temperature for comparison with the corresponding set (*a*) at different temperatures was obtained. These two sets of curves are not shown in the figures. They were only a step in the reduction, and were not intrinsically interesting.

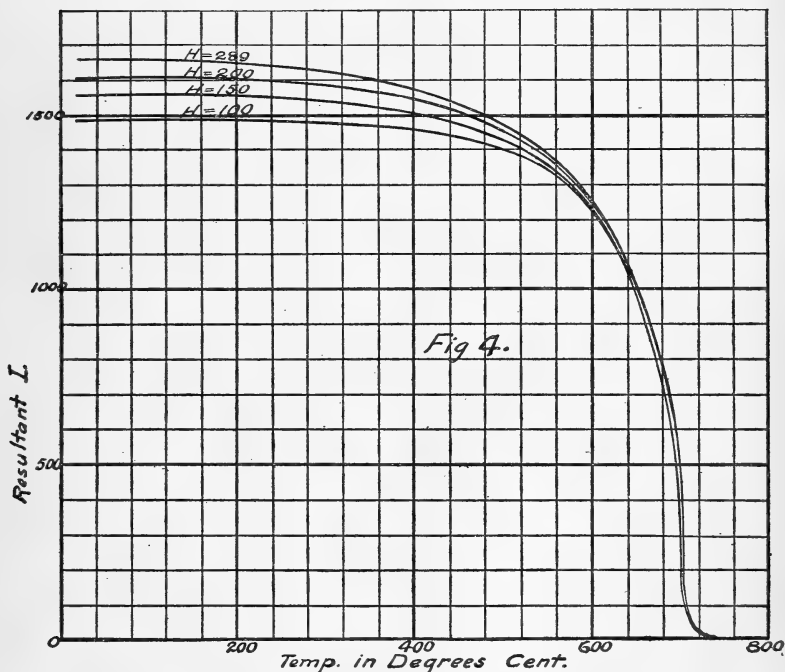

Effect of Temperature on the Magnetization of Iron in High Fields.

The final result showing the effect of temperature in high fields is shown in fig. 4. Here ordinates represent average resultant intensity and abscissæ temperature in degrees centigrade. Each curve is drawn for a constant average resultant field.

Verification and Discussion of Results.

It is interesting to notice in fig. 3 the limiting effect of the circular magnetization in high fields. The curves up to 12 amps. in the wire almost coincide at a longitudinal field of 150 c.g.s.

To test how far the results in fig. 3 were reliable, the wire was mounted in a glass tube and a water circulation allowed to flow through the tube in contact with the wire. Thus the temperature of the wire was kept practically constant for all values of the current. The results of these tests agreed very closely indeed with those shown in fig. 3, even down to a field of 10 c.g.s.

Klemencic (*Wied Ann.* vol. lvi. p. 574) investigated the circular magnetization of iron wires together with the axial magnetization by a different method. By including the wire as an arm of a Wheatstone's bridge and using a ballistic galvanometer, the circular magnetization was deduced from the observed value of the self-induction for different currents in the wire. Here the change of temperature of wire introduces difficulties. It seems that the magnetometer method, when the wire is kept at a constant temperature, is much simpler and less troublesome.

The results shown in fig. 4 were found to agree closely with the tests obtained for soft iron by the platinum-tube method. The point of demagnetization was obtained a trifle lower by the latter method, and the initial slope of the curve at a field of 290 c.g.s. was a little less. It will be noted that the point of demagnetization is not absolutely sharp; the curves suddenly change their direction and I decreases more slowly. This was also investigated in special tests made by the platinum-tube method. The value of I at 750° C. was observed to be about 7 c.g.s.

These results are found to agree very well with those for soft iron in high fields obtained by Curie (*Comptes Rendus*, vol. cxviii. p. 859). He heated his specimen in a platinum heating-coil and measured the temperature inside the coil by a thermo-couple. The point of demagnetization which he obtained is rather higher than that obtained by the platinum-tube or current-in-the-wire methods, but not so high as that given by Hopkinson (*loc. cit.*) who used a copper wire for his temperature measurements. More recently a paper has appeared by Morris (*Phil. Mag.* vol. xlv. Sept. 1897), who employed the same method of heating as Curie, but measured the temperature with a platinum wire. It will be seen that the method of heating with a coil is less perfect than with

a platinum tube, and less simple than the current in the wire.

The results of the foregoing experiments were communicated to Section G of the British Association at Toronto, and a brief abstract appears in the B. A. Report for 1897, but the curves were not reproduced.

In conclusion, I should like to thank Professor Callendar for kind suggestions and other assistance.

Macdonald Physics Laboratory,
December 20, 1898.

XL. The Equivalent Resistance and Inductance of a Wire to an Oscillatory Discharge. By EDWIN H. BARTON, D.Sc., F.R.S.E., Senior Lecturer in Physics, University College, Nottingham*.

IN an article in the Philosophical Magazine for May 1886 †, Lord Rayleigh, whilst greatly extending Maxwell's treatment of the self-induction of cylindrical conductors, confined the discussion of alternating currents to those which followed the harmonic law with constant amplitude. The object of the present note is to slightly modify the analysis so as to include also the decaying periodic currents obtained in discharging a condenser and the case of the damped trains of high-frequency waves generated by a Hertzian oscillator and now so often dealt with experimentally. In fact, it was while recently working with the latter that the necessity of attacking this problem occurred to me.

Résumé of previous Theories.—To make this paper intelligible without repeated references to both Maxwell and Rayleigh, it may be well to explain again the notation used and sketch the line of argument followed.

The conducting wire is supposed to be a straight cylinder of radius a , the return wire being at a considerable distance. The vector potential, H , the density of the current, w , and the "electromotive force at any point" may thus be considered as functions of two variables only, viz., the time, t , and the distance, r , from the axis of the wire. The total current, C , through the section of the wire, and the total electromotive force, E , acting round the circuit, are the variables whose relation is to be found. It is assumed that

$$H = S + T_0 + T_1 r^2 + \dots + T_n r^{2n}, \quad \dots \quad (1)$$

* Communicated by the Physical Society: read January 27, 1899.

† "On the Self-Induction and Resistance of Straight Conductors."

where S, T₀, T₁, &c., are functions of the time. A relation between the T's is next established so that the subscripts are replaced by coefficients. The value of H at the surface of the wire is equated to AC, where A is a constant. This leads to Maxwell's equation (13) of art. 690. The magnetic permeability, μ, of the wire, which Maxwell had treated as unity, is now introduced by Lord Rayleigh, who thus obtains in place of Maxwell's (14) and (15) the following equations:—

$$\mu C = - \left(\alpha \mu \frac{dT}{dt} + \frac{2\alpha^2 \mu^2}{1^2 \cdot 2^2} \cdot \frac{d^2 T}{dt^2} + \dots + \frac{n\alpha^n \mu^n}{1^2 \cdot 2^2 \dots n^2} \cdot \frac{d^n T}{dt^n} + \dots \right), \dots \quad (2)$$

$$AC - S = T + \alpha \mu \frac{dT}{dt} + \frac{\alpha^2 \mu^2}{1^2 \cdot 2^2} \frac{d^2 T}{dt^2} + \dots + \frac{\alpha^n \mu^n}{1^2 \cdot 2^2 \dots n^2} \frac{d^n T}{dt^n} + \dots, \quad (3)$$

where α, equal to l/R, represents the conductivity (for steady currents) of unit length of the wire.

By writing

$$\phi(x) = 1 + x + \frac{x^2}{1^2 \cdot 2^2} + \dots + \frac{x^n}{1^2 \cdot 2^2 \dots n^2} + \dots \quad (4)$$

equations (2) and (3) are then transformed as follows:

$$\frac{dS}{dt} = A \frac{dC^*}{dt} - \phi \left(\alpha \mu \frac{d}{dt} \right) \cdot \frac{dT}{dt}, \quad \dots \quad (5)$$

$$C = -\alpha \phi' \left(\alpha \mu \frac{d}{dt} \right) \cdot \frac{dT}{dt}; \quad \dots \quad (6)$$

we have further

$$\frac{E}{l} = \frac{dS}{dt} \cdot \dots \quad (7)$$

Lord Rayleigh then applies equations (5), (6), and (7) to sustained periodic currents following the harmonic law, where all the functions are proportional to e^{ipt}, and obtains

$$E = R'C + ipL'C, \quad \dots \quad (8)$$

R' and L' denoting the effective resistance and inductance respectively to the currents in question. The values of R' and L' are expressed in the form of infinite series. For high frequencies, however, they are put also in a finite form, since, when p is very great, equation (4) reduces analytically to

$$\phi(x) = \frac{1}{2\sqrt{\pi}} \frac{e^{2\sqrt{x}}}{x^{\frac{1}{2}}}, \quad \dots \quad (9)$$

* AC is printed here in Phil. Mag., May 1886, p. 387; but appears to be a slip for A $\frac{dC}{dt}$.

so that

$$\frac{\phi(x)}{\phi'(x)} = x^{\frac{1}{2}}. \quad \dots \quad (10)$$

Equivalent Resistance and Inductance for Oscillatory Discharges.—To effect the object of this paper we must now apply equations (5), (6), and (7) to the case of logarithmically-damped alternating currents where all the functions are proportional to $e^{(i-k)pt}$.

The value of E so obtained must then be separated into real and imaginary parts as in (8), and then, together with the imaginary quantities, must be collected a proportionate part of the real ones so as to exhibit the result in the form

$$E = R''C + (i-k)pL''C. \quad \dots \quad (11)$$

The quantities denoted by R'' and L'' in this equation will then represent what may be called the *equivalent* resistance and inductance of length l of the wire to the damped periodic currents under discussion. For, the operand being now $e^{(i-k)pt}$, the time differentiator produces $(i-k)p$, and not ip simply as in equation (8) for the sustained harmonic currents.

Thus (5), (6), and (7), on elimination of S , l , and $\frac{d\Gamma}{dt}$, give

$$\frac{E}{RC} = (i-k)p\alpha A + \frac{\phi(ip\alpha\mu - kp\alpha\mu)}{\phi'(ip\alpha\mu - kp\alpha\mu)}. \quad \dots \quad (12)$$

Now we have

$$\frac{\phi(x)}{\phi'(x)} = 1 + \frac{x}{2} - \frac{x^2}{12} + \frac{x^3}{48} - \frac{x^4}{180} + \dots; \quad (13)$$

thus

$$\begin{aligned} & \frac{\phi(ip\alpha\mu - kp\alpha\mu)}{\phi'(ip\alpha\mu - kp\alpha\mu)} \\ &= 1 - \frac{1}{2}kp\alpha\mu + \frac{1-k^2}{12}p^2\alpha^2\mu^2 + \frac{k(3-k^2)}{48}p^3\alpha^3\mu^3 - \frac{1-6k^2+k^4}{180}p^4\alpha^4\mu^4 \dots \\ &+ i \left\{ \frac{1}{2}p\alpha\mu + \frac{k}{6}p^2\alpha^2\mu^2 - \frac{1-3k^2}{48}p^3\alpha^3\mu^3 - \frac{4k(1-k^2)}{180}p^4\alpha^4\mu^4 \dots \right\}. \quad (14) \end{aligned}$$

Hence, substituting (14) in (12) and collecting the terms as in (11), we find that

$$\frac{R''}{R} = 1 + \frac{1+k^2}{12}p^2\alpha^2\mu^2 + \frac{k(1+k^2)}{24}p^3\alpha^3\mu^3 - \frac{1-2k^2-3k^4}{180}p^4\alpha^4\mu^4 \dots, \quad (15)$$

and

$$\left. \begin{aligned} \frac{L''}{R} &= \alpha A + \frac{1}{2} \alpha \mu + \frac{k}{6} p \alpha^2 \mu^2 - \frac{1-3k^2}{48} p^2 \alpha^3 \mu^3 - \frac{k(1-k^2)}{45} p^3 \alpha^4 \mu^4 \dots \\ \text{or} \\ L'' &= l \left[A + \mu \left(\frac{1}{2} + \frac{k}{6} p \alpha \mu - \frac{1-3k^2}{48} p^2 \alpha^2 \mu^2 - \frac{k(1-k^2)}{45} p^3 \alpha^3 \mu^3 \dots \right) \right] \end{aligned} \right\} (16)$$

Putting $k=0$ in these equations and denoting by single-dashed letters the corresponding values of the resistance and inductance, we have

$$\frac{R'}{R} = 1 + \frac{1}{12} p^2 \alpha^2 \mu^2 - \frac{1}{180} p^4 \alpha^4 \mu^4 \dots, \quad . \quad (17)$$

and

$$L' = l \left[A + \mu \left(\frac{1}{2} - \frac{1}{48} p^2 \alpha^2 \mu^2 \dots \right) \right], \quad . \quad (18)$$

which are Lord Rayleigh's well-known formulæ* for periodic currents of constant amplitude.

By taking the differences of the resistances and inductances with damping and without, we have at once

$$\frac{R'' - R'}{R} = k^2 p^2 \alpha^2 \mu^2 + \frac{k(1-k^2)}{24} p^3 \alpha^3 \mu^3 + \dots \quad (19)$$

and

$$L'' - L' = l \mu \left(\frac{k}{6} p \alpha \mu + \frac{k^2}{6} p^2 \alpha^2 \mu^2 \dots \right) \quad (20)$$

These show that if the frequency is such that a few terms sufficiently represent the value of the series, then *both resistance and inductance are increased by the damping.*

High-Frequency Discharges.—Passing now to cases where p is very great, as in the wave-trains in or induced by a Hertzian primary oscillator, we have from equation (10),

$$\frac{\phi(ip\alpha\mu - k p \alpha \mu)}{\phi'(ip\alpha\mu - k p \alpha \mu)} = \sqrt{(i-k)p\alpha\mu} = (p\alpha\mu s)^{\frac{1}{2}} \left(i \cos \frac{\theta}{2} + \sin \frac{\theta}{2} \right), \quad (21)$$

where $s = \sqrt{1+k^2}$ and $\cot \theta = k$.

On substituting this value of ϕ/ϕ' in equation (12) and collecting as before, we obtain the solution sought, viz.:

$$\frac{E}{RC} = (\alpha\mu p s^3)^{\frac{1}{2}} \cos \frac{\theta}{2} + (i-k)p \left(\alpha A + \sqrt{\alpha\mu s/p} \cos \frac{\theta}{2} \right); \quad (22)$$

whence

$$\frac{R''}{R} = (\alpha\mu p s^3)^{\frac{1}{2}} \cos \frac{\theta}{2}, \quad . \quad . \quad . \quad (23)$$

* Equations (19) and (20), p. 387, *loc. cit.*

and
$$\frac{L''}{R} = \alpha A + (\alpha \mu s / p)^{\frac{1}{2}} \cos \frac{\theta}{2},$$
 or
$$L'' = l \left[A + \left(\frac{\mu s}{\alpha p} \right)^{\frac{1}{2}} \cos \frac{\theta}{2} \right]. \quad \dots \dots (24)$$

Discussion of the Results for High Frequencies.

On putting $k=0$, in equations (23) and (24), to reduce to the case of sustained simple harmonic waves, $s=1$, $\theta = \frac{\pi}{2}$; whence, denoting by single dashes these special values of R'' and L'' , we obtain

$$\frac{R'}{R} = \sqrt{\frac{1}{2} \alpha \mu p}; \quad \dots \dots (25)$$

and
$$L' = l \left\{ A + \sqrt{\frac{\mu}{2 \alpha p}} \right\}, \quad \dots \dots (26)$$

which are Lord Rayleigh's high-frequency formulæ*.

Referring again to equations (23) and (24), we see that for a given value of p , if k varies from 0 to ∞ , the factor involving s increases without limit while that involving θ increases to unity. Hence, with increasing damping, it appears that R'' and L'' each increase also, while ever the equations remain applicable. Now an infinite value of k involves zero frequency †. And a certain large, though finite, value of k would prevent the frequency being classed as "high."

Dividing equation (23) by (25) gives

$$\frac{R''}{R'} = (2s^3)^{\frac{1}{2}} \cos \frac{\theta}{2} = K \text{ say.} \quad \dots \dots (27)$$

Thus, for a given value of k , the ratio R''/R' is independent of the frequency of the waves. It is therefore convenient to deal with K a function of k only, rather than with R''/R which is a function of p also.

Differentiating to k , we have

$$\frac{dK}{dk} = \frac{3k \cos \frac{\theta}{2} + \sin \frac{\theta}{2}}{\sqrt{2s}}, \quad \dots \dots (28)$$

* Equations (26) and (27), p. 390, *loc. cit.*

† This follows from the fact that electric currents or waves generated by an oscillatory discharge may be represented by $e^{-kpt} \cos pt$, in which kp is finite, so k is infinite only when p is zero.

Fig. 1.—Exhibiting graphically $K=R''/R'$ as a function of k , the damping factor.

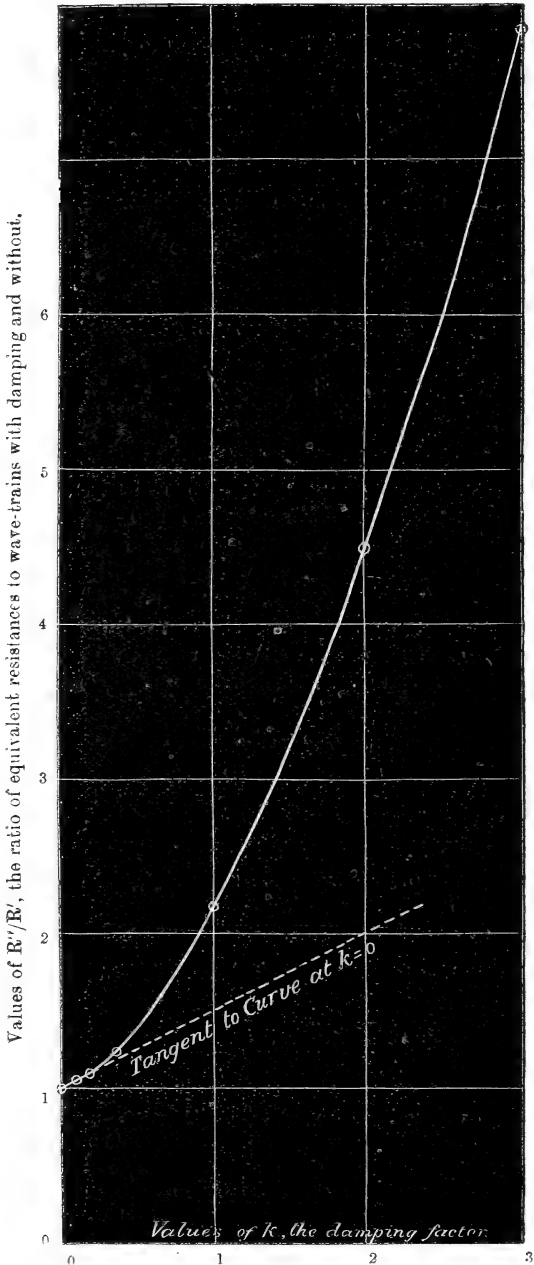

which is positive for all values of k from 0 to ∞ , hence K increases continuously with k . For $k=0$, this becomes

$$\left(\frac{dK}{dk}\right)_{k=0} = \frac{\sin \frac{\pi}{4}}{\sqrt{2}} = \frac{1}{2}, \dots \dots (29)$$

which assists in plotting K as a function of k .

Differentiating again, we obtain

$$\frac{d^2K}{dk^2} = \frac{1}{\sqrt{2^3 s^5}} \left\{ (7 + 3k^2) \cos \frac{\theta}{2} + 2k \sin \frac{\theta}{2} \right\} \dots (30)$$

Since this expression is positive for all values of k from 0 to ∞ , we see that K plotted as a function of k is a curve which is always convex to the axis of k . Thus the nature of R''/R' as a function of k is sufficiently determined.

Pairs of corresponding values of K and k for a few typical cases are shown in the accompanying Table, and part of the curve coordinating them is given in fig. 1. It is not necessary to plot much of the curve, as only a small part of it can apply to any actual case. For, although k may have any positive value up to ∞ , the high values of k , as already mentioned, correspond to low values of p and so exclude them from the application of the high-frequency formula.

TABLE showing the values of $K=R''/R'$, the ratio of equivalent resistances to waves with damping and without.

Damping Factor, $k = \cot \theta.$	Subsidiary quantities involved.		Ratio of Resistances $K=R''/R'.$
	$\theta/2.$	$s^2 = 1+k^2.$	
0	45°	1	1
$\frac{1}{4\pi} = 0.0798$	42° 44'	1.006362	1.044 nearly
$\frac{3}{10\pi} = 0.0955$	42° 16'	1.00913	1.054 „
$\frac{1}{2\pi} = 0.1595$	40° 28'	1.02614	1.097 „
$\frac{1}{\pi} = 0.319$	36° 9'	1.1018	1.228 „
1	22° 30'	2	2.197 „
2	13° 17'	5	4.602 „
3	9° 13'	10	7.85 „

Fig. 2.—Instantaneous Form of Wave-train for $k=1$, whence $R''/R' = 2.197$.

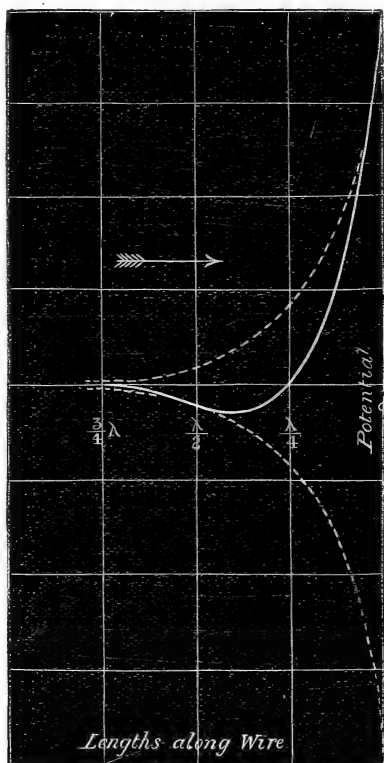
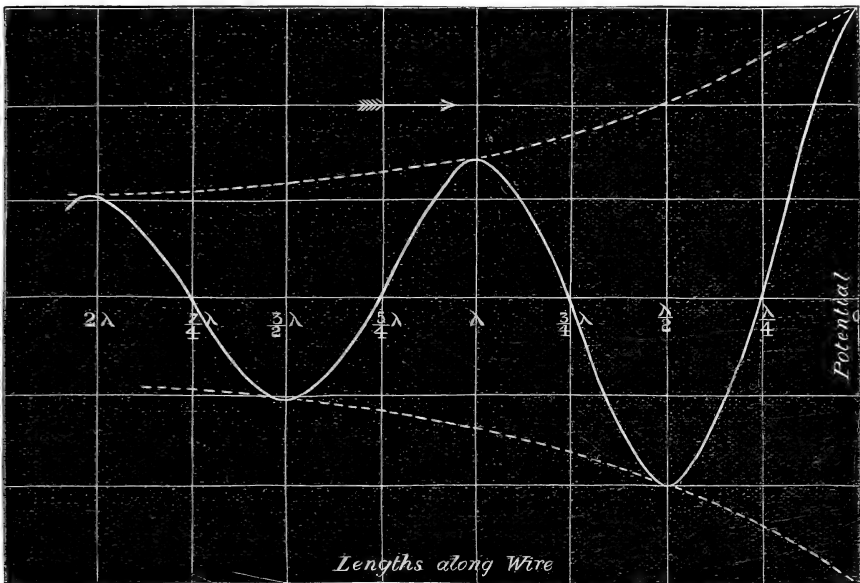

Figure 2 shows the form of a wave-train for which $k=1$ and $K=2.197$. That is to say, in this extreme case where all the functions vary as $e^{(i-1)pt}$, and the wave-train passing a given point of the wire is accordingly represented by $e^{-pt} \cos pt$, then the equivalent resistance is 2.197 times that which would obtain for simple harmonic waves uniformly sustained and of the same frequency.

Figure 3 represents the form of the wave-trains generated and used in some recent experiments on attenuation*. In this case the value of k was approximately $\frac{3}{10\pi}$, or the logarithmic decrement per wave $=2\pi k=0.6$, and the corresponding value of K , the ratio of R''/R' , is 1.054. Now in

* "Attenuation of Electric Waves along a Line of Negligible Leakage," *Phil. Mag.* Sept. 1898, pp. 296-305.

Fig. 3.—Instantaneous Form of Wave-Train for $k=3/\pi$, whence $R''/R'=1.054$.



the experiments just referred to the frequency was 35×10^6 per second, and R'/R became 31.6. Hence R''/R has the value $31.6 \times 1.054 = 33.3$ nearly. Thus, writing $e^{-R''x/2Lv}$ for the attenuator of the waves along the wires instead of $*e^{-R'x/2Lv}$ increases the index by about five and a half per cent., and so brings it by that amount nearer to the value determined experimentally.

Univ. Coll., Nottingham,
Nov. 29, 1898.

XLI. *On certain Diffraction Fringes as applied to Micrometric Observations.* By L. N. G. FILON, M.A., Demonstrator in Applied Mathematics and Fellow of University College, London†.

1. **T**HE following paper is largely criticism and extension of Mr. A. A. Michelson's memoir "On the Application of Interference Methods to Astronomical Observations," published in the *Phil. Mag.* vol. xxx. p. 256, March 1891.

* See Equation (2) p. 301, *Phil. Mag.* Sept. 1898.

† Communicated by the Physical Society: read November 25, 1898.

Light from a distant source is allowed to pass through two thin parallel slits. The rays are then focussed on a screen (or the retina of the eye) and interference-fringes are seen. If the distant source be really double, or extended, the fringes will disappear for certain values of the distance between the slits. This distance depends on the angle subtended by the two components of the double source or the diameter of the extended source.

Mr. Michelson, however, in obtaining his results treated the breadth of the slits as small compared with the wavelength of light and their length as infinite. This seems unjustifiable *à priori*. The present investigation takes the dimensions of the slits into account.

2. Suppose we have an aperture or diaphragm of any shape in a screen placed just in front of the object-glass of a telescope (fig. 1).

Fig. 1.

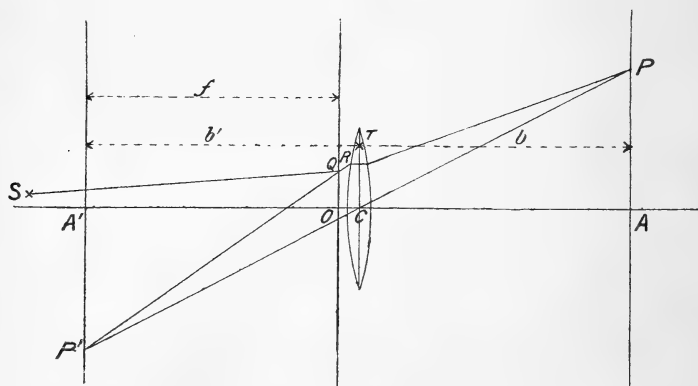

Let the axis of the telescope be the axis of z . Let the axes of x and y be taken in the plane of the diaphragm OQ perpendicular to and in the plane of the paper respectively. Let S be a source of light whose coordinates are U, V, W . Let Q be any point in the diaphragm whose coordinates are (x, y) . Let AP be a screen perpendicular to the axis of the telescope, and let (p, q) be the coordinates of any point P on this screen. Let $A'P'$ be the conjugate image of the screen AP in the object-glass.

Let b = distance of centre C of lens from screen AP .

b' = " " " " image of screen AP .

f = distance of diaphragm OQ from plane $A'P'$.

Then if, as is usual, we break up a wave of light coming

from S at the diaphragm, the secondary wave due to the disturbance at Q would have to travel along a path QRTP in order to reach a point P on the screen, being regularly refracted.

But since P' is the geometrical image of P, all rays which converge to P (*i. e.* pass through P) after refraction, must have passed through P' before refraction, to the order of our approximation.

Hence the ray through Q which is to reach P must be P'Q.

Moreover, P and P' being conjugate images the change of phase of a wave travelling from P' to P is constant to the first approximation and independent of the position of Q.

Now the disturbance at P due to an element $dx dy$ of the diaphragm at Q is of the form

$$\frac{A dx dy}{b\lambda} \sin \frac{2\pi}{\lambda} \left(\frac{\lambda t}{\tau} - SQ - QR - \mu \cdot RT - TP \right),$$

where λ is the wave-length, τ is the period, A is a constant, μ is the index of refraction of the material of the lens, and b is put instead of QP outside the trigonometrical term, because the distance of the lens from the diaphragm and the inclination of the rays are supposed small.

But $P'Q + QR + \mu RT + TP = \text{constant for P.}$

Therefore the disturbance

$$= \frac{A dx dy}{b\lambda} \sin \frac{2\pi}{\lambda} \left(\frac{\lambda t}{\tau} - SQ + P'Q - \text{const.} \right).$$

But

$$SQ^2 = (x - U)^2 + (y - V)^2 + W^2$$

$$P'Q^2 = \left(x + \frac{b'}{b} p\right)^2 + \left(y + \frac{b'}{b} q\right)^2 + f^2.$$

Now in practice x, y, p, q are small compared with b', b, f , or W ; U and V are small compared with W . Neglecting terms of order $U^3/W^3, xU^2/W^3, \&c.$, we find

$$SQ = \sqrt{U^2 + V^2 + W^2} - \frac{U}{W} x - \frac{V}{W} y + \frac{1}{2} \frac{x^2 + y^2}{W}.$$

In like manner

$$P'Q = b' \sqrt{\frac{f^2}{b'^2} + \frac{p^2 + q^2}{b^2}} + \frac{px}{b} + \frac{qy}{b} + \frac{1}{2} \frac{x^2 + y^2}{b'},$$

remembering that f is very nearly equal to b' because the diaphragm is very close to the lens.

Hence the difference of retardation measured by length in air

$$P'Q - SQ = \text{const.} + \left(\frac{p}{b} + \frac{U}{W}\right)x + \left(\frac{q}{b} + \frac{V}{W}\right)y + \frac{1}{2}(x^2 + y^2)\left(\frac{1}{b'} - \frac{1}{W}\right).$$

If now the geometrical image of S lie on the screen AP (*i.e.* if the screen is in correct focus) $b' = W$ and the last term disappears.

If, however, the screen be out of focus $1/b'$ is not equal to $1/W$, and the term in $x^2 + y^2$ may be comparable with the two others, if b' be not very great compared with b . Thus we see that appearances out of focus will introduce expressions of the same kind as those which occur when no lenses are used.

We will, however, only consider the case where the screen is in focus. Let $-u$ and $-v$ be the coordinates of the geometrical image of S; then

$$u/b = U/W, \quad v/b = V/W.$$

The difference of retardation measured by length in air is therefore of the form

$$P'Q - SQ = \text{const.} + \frac{p+u}{b}x + \frac{q+v}{b}y.$$

Hence the total disturbance at P (integrating over the two slits) is given by the expression

$$D = \frac{A}{b\lambda} \int_{a-k}^{a+k} dy \int_{-h}^h dx \sin \frac{2\pi}{\lambda} \left(\frac{\lambda t}{\tau} + \frac{p+u}{b}x + \frac{q+v}{b}y \right) + \frac{A}{b\lambda} \int_{-a-k}^{-a+k} dy \int_{-h}^h dx \sin \frac{2\pi}{\lambda} \left(\frac{\lambda t}{\tau} + \frac{p+u}{b}x + \frac{q+v}{b}y \right),$$

where

$A =$ a constant,

$2a =$ distance between centres of slits,

$2k =$ breadth of either slit,

$2h =$ length of either slit.

This, being integrated out, gives

$$D = \frac{2Ab\lambda}{\pi^2(p+u)(q+v)} \sin \frac{2\pi t}{\tau} \cos \frac{2\pi q+v}{\lambda} \frac{a}{b} \sin \frac{2\pi q+v}{\lambda} \frac{k}{b} \sin \frac{2\pi p+u}{\lambda} \frac{h}{b},$$

whence the intensity of light

$$I = \frac{4A^2 b^2 \lambda^2}{\pi^4 (p+u)^2 (q+v)^2} \cos^2 \frac{2\pi a}{b\lambda} (q+v) \sin^2 \frac{2\pi k}{b\lambda} (q+v) \sin^2 \frac{2\pi h}{b\lambda} (p+u).$$

This may be written

$$\frac{64A^2 k^2 h^2}{b^2 \lambda^2} \cos^2 \frac{2\pi a}{b\lambda} (q+v) \frac{\sin^2 \frac{2\pi k}{b\lambda} (q+v) \sin^2 \frac{2\pi h}{b\lambda} (p+u)}{\left(\frac{2\pi k}{b\lambda} (q+v)\right)^2 \left(\frac{2\pi h}{b\lambda} (p+u)\right)^2}.$$

This gives fringes parallel to x and y : k being very small compared with a , the quick variation term in v is

$$\cos^2 \frac{2\pi a}{b\lambda} (q+v).$$

Consider the other two factors, namely :

$$\frac{\sin^2 \frac{2\pi k}{b\lambda} (q+v)}{\left\{ \frac{2\pi k}{b\lambda} (q+v) \right\}^2} \quad \text{and} \quad \frac{\sin^2 \frac{2\pi h}{b\lambda} (p+u)}{\left\{ \frac{2\pi h}{b\lambda} (p+u) \right\}^2}.$$

If we draw the curve $y = \frac{\sin^2 x}{x^2}$ (see fig. 2), we see that these factors are only sensible, and therefore their product is only sensible, for values of $p+u$ and $q+v$ which are numerically less than $b\lambda/2h$ and $b\lambda/2k$ respectively.

Fig. 2.

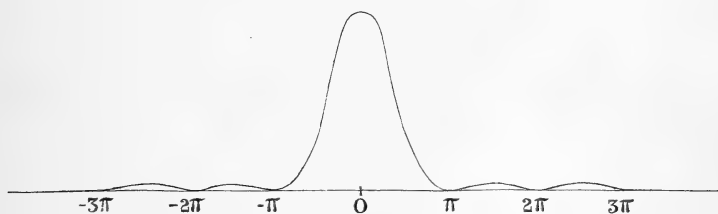

Hence the intensity becomes very small outside a rectangle whose centre is the geometrical image and whose vertical and horizontal sides are $b\lambda/k$ and $b\lambda/h$ respectively.

This rectangle I shall refer to as the "visible" rectangle of the source.

Inside this rectangle are a number of fringes, the dark lines being given by

$$q+v = \frac{2n+1}{4a} b\lambda$$

and the bright ones by $q+v = n b\lambda/2a$.

The successive maximum and minimum intensities do not vary with a . Hence, what Mr. Michelson calls the measure of visibility of the fringes, namely the quantity

$$\frac{I_1 - I_2}{I_1 + I_2},$$

where I_1, I_2 are successive maximum and minimum intensities, does not vary with the distance between the slits. The only effect of varying the latter is to make the fringes close up or open out. Hence for a point-source of light the fringes cannot be made to practically disappear.

3. Consider now two point-sources of light whose geometrical images are J_1, J_2 , and draw their visible rectangles (fig. 3).

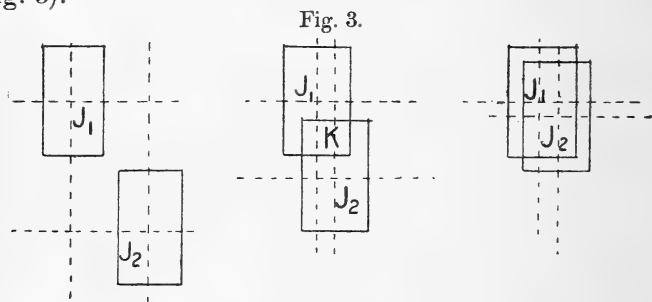

To get the resultant intensity we have to add the intensities at every point due to each source separately.

Then it may be easily seen that the following are the phenomena observed in the three cases shown in fig. 3:—

(1) The two sets of fringes distinct. Consequently no motion of the slits can destroy the fringes. In this case, however, the eye can at once distinguish between the two sources and Michelson's method is unnecessary.

(2) Partial superposition: the greatest effect is round the point K , where the intensities due to the two sources are very nearly equal. If $v' - v$ be the distance between J_1 and J_2 measured perpendicularly to the slits, so that $(v' - v)/b$ is the difference of altitude of the two stars when the slits are horizontal, then over the common area the fringe system is (a) intensified if $v' - v$ be an even multiple of $b\lambda/4a$, (b) weakened, or even destroyed, if $v' - v$ be an odd multiple of $b\lambda/4a$. For in case (a) the maxima of one system are superposed upon the maxima of the other, while in case (b) the maxima of the one are superposed upon the minima of the other. This common area, however, will contain only comparatively faint fringes, the more distinct ones round the

centres remaining unaffected. We may suppose case (2) to occur whenever the centre of either rectangle lies outside the other, *i. e.* whenever $v' - v > b\lambda/2k$, $u' - u > b\lambda/2h$, $u' - u$ being the horizontal distance between J_1 and J_2 .

(3) Almost complete superposition of the visible rectangles. The fringes of high intensity are now affected. These are destroyed or weakened whenever a is an odd multiple of $b\lambda/4(v' - v)$, provided that the intensity of one source be not small compared with that of the other.

Case (3) may be taken to occur when $v' - v < b\lambda/2k$ and $u' - u < b\lambda/2h$.

The smallest value of a for which the fringes disappear is $b\lambda/4(v' - v)$.

If $v' - v$ be very small, this may give a large value of a .

Now a double star ceases to be resolved by a telescope of aperture $2r$ if $(v' - v)/b < \lambda/2r$, and when this relation holds the smallest value of a for which the fringes disappear is not less than $r/2$, which is the greatest separation of the slits which can conveniently be used. Hence the method ceases to be available precisely at the moment when it is most needed.

(4) Mr. Michelson, in the paper quoted above, noticed this difficulty, and described an apparatus by means of which the effective aperture of the telescope could be indefinitely increased. He has not shown, however, that the expression for the disturbance remains of the same form, to the order of approximation taken, and he has made no attempt to work out the results when the slit is taken of finite width, as it should be.

In his paper Mr. Michelson describes two kinds of apparatus. I shall confine my attention to the second one, as being somewhat more symmetrical.

So far as I can gather from Mr. Michelson's description, the instrument consists primarily of a system of three mirrors a, b, c and two strips of glass e, d (fig. 4). The mirrors a and b are parallel, and c, d, e are parallel. Light from a point P in one slit is reflected at Q and R by the mirrors a and b , is refracted through the strip e , and finally emerges parallel to its original direction as TU . Light from a point P' in the other slit is refracted through the strip d , and reflected at S' and T' by the strips e and c .

I may notice in passing that the strip e should be half silvered, but *not at the back*, for if the ray $S'T'$ is allowed to penetrate inside the strip and emerge after two refractions and one reflexion, not only is a change of phase introduced, owing to the path in the glass, which complicates the analysis,

but the conditions of reflexion, which should be the same for all four mirrors, are altered, and this changes the intensities of the two streams. We shall see afterwards that this silvering can be done without impeding the passage of the transmitted stream, as it will turn out that the two streams must be kept separate.

Fig. 4.

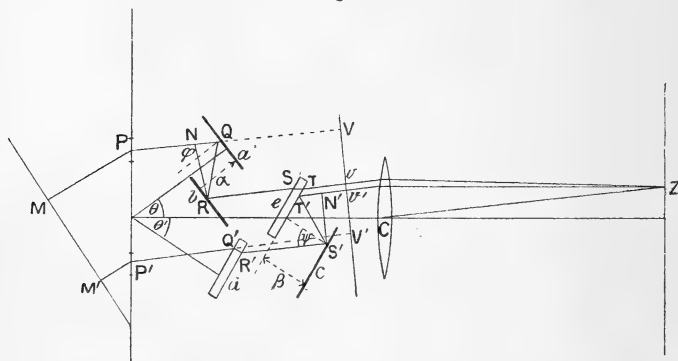

Suppose then that a plane wave of light whose front is MM' is incident upon the diaphragm. Let us break the wave up, as is usual, in the plane of the diaphragm. Let Z be a point on the screen whose coordinates are (p, q) at which the intensity of light is required.

Then if C be the centre of the object-glass, the direction in which rays $TU, T'U'$ must proceed in order to converge to Z after refraction is parallel to CZ .

Hence $PQ, RS, TU, P'Q', R'S', T'U'$ are all parallel to CZ , and the direction-cosines of CZ are

$$\frac{p}{\sqrt{p^2 + q^2 + b^2}}, \quad \frac{q}{\sqrt{p^2 + q^2 + b^2}}, \quad \frac{b}{\sqrt{p^2 + q^2 + b^2}}.$$

I shall assume that the strips e and d are cut from the same plate and are of equal thickness. This will sensibly simplify the analysis, though, as I think, it would not materially influence the appearances if the strips were unequal.

If, however, we suppose them equal, we may neglect the presence of strips, as far as refraction is concerned, since clearly the retardation introduced is the same for all parallel rays.

If now UU' be a plane perpendicular to CZ , then, since we know that rays parallel to $TU, T'U'$ converge to a focus at Z , the only parts of the paths of the rays which can introduce a

difference of phase are

MP + PQ + QR + RS + TU for one stream,

M'P' + P'Q' + R'S' + S'T' + T'U' for the other stream.

Produce PQ, P'Q' to meet it in V and V' and let N, N' be the feet of the perpendiculars from R and S' on PQ, T'U' respectively.

Thus we may take the change of phase as due to the retardation

$$(MP + PV) + (NQ + QR)$$

for diffraction at one slit, and to the retardation

$$(M'P' + P'V') + (S'T' + T'N')$$

for rays proceeding from the other slit.

The terms in the first brackets give us the expression which we had before, viz. :—

$$-\left(\frac{p+u}{b}\right)x - \left(\frac{q+v}{b}\right)y + \text{const.}$$

As to the other terms

$$NQ + QR = QR (1 + \cos 2\phi) = \alpha \frac{1 + \cos 2\phi}{\cos \phi} = 2\alpha \cos \phi,$$

where α is the distance between the mirrors a , b and ϕ is the angle of incidence of any ray on these mirrors.

Similarly $S'T' + T'N' = 2\beta \cos \psi$, where β is the distance between e and c and ψ the angle of incidence of any ray upon e and c .

Now if the mirrors a and b are inclined to the plane of the diaphragm at an angle θ , c , d , e at an angle $(-\theta')$, then

$$\cos \phi = \frac{q \sin \theta + b \cos \theta}{\sqrt{p^2 + q^2 + b^2}},$$

$$\cos \psi = \frac{-q \sin \theta' + b \cos \theta'}{\sqrt{p^2 + q^2 + b^2}},$$

To find the disturbance at Z we have

$$\int_{a-k}^{a+k} dy \int_{-h}^{+h} dx \frac{A}{b\lambda} \sin \frac{2\pi}{\lambda} \left(\frac{\lambda t}{\tau} + \frac{p+u}{b}x + \frac{q+v}{b}y - 2\alpha \cos \phi \right)$$

$$+ \int_{-a-k}^{-a+k} dx \frac{A}{b\lambda} \sin \frac{2\pi}{\lambda} \left(\frac{\lambda t}{\tau} + \frac{p+u}{b}x + \frac{q+v}{b}y - 2\beta \cos \psi \right),$$

which, on being integrated, gives

$$\frac{2Ab\lambda}{\pi^2(p+u)(q+v)} \sin \frac{2\pi}{\lambda} \frac{q+v}{b} k \sin \frac{2\pi}{\lambda} \frac{p+u}{b} h \sin \frac{2\pi}{\lambda} \left(\frac{\lambda t}{\tau} - \epsilon \right) \cos \frac{2\pi\gamma}{\lambda},$$

where $-\epsilon - \gamma = -\frac{v+q}{b}a - 2\beta \cos \psi$, $-\epsilon + \gamma = \frac{v+q}{b}a - 2\alpha \cos \phi$,

whence $\epsilon = \alpha \cos \phi + \beta \cos \psi$,

$$\gamma = \frac{v+q}{b}a + \beta \cos \psi - \alpha \cos \phi.$$

Hence the intensity I of light at (p, q) is

$$\frac{4A^2b^2\lambda^2}{\pi^4(p+u)^2(q+v)^2} \sin^2 \frac{2\pi}{\lambda} \frac{q+v}{b} v \sin^2 \frac{2\pi}{\lambda} \frac{p+u}{b} h \cos^2 \frac{2\pi\gamma}{\lambda}$$

where $\gamma = \frac{v+q}{b}a + \frac{\beta \cos \theta' - \alpha \cos \theta}{\sqrt{p^2 + q^2 + b^2}} b - \frac{(\beta \sin \theta' + \alpha \sin \theta)}{\sqrt{p^2 + q^2 + b^2}} q$.

In the last term we may put $\frac{q}{\sqrt{p^2 + q^2 + b^2}} = \frac{q}{b}$, for if we went

to a higher approximation, we should introduce *cubes* of p/b , q/b which we have hitherto neglected.

If, further, we make $\beta \cos \theta' = \alpha \cos \theta$, which can always be managed without difficulty, the second term, which would contain squares on expansion, disappears and we have

$$\gamma = \frac{(v+q)a - (\beta \sin \theta' + \alpha \sin \theta)q}{b}$$

$$= \{va + q(a - (\beta \sin \theta' + \alpha \sin \theta))\} / b.$$

This gives fringes of breadth $b\lambda/2(a - (\beta \sin \theta' + \alpha \sin \theta))$. These may be reckoned from the bright fringe $\gamma=0$; *i. e.*

$$q_0 = \frac{-va}{a - (\beta \sin \theta' + \alpha \sin \theta)}.$$

The visibility of the fringes for a single source will, as before, not be affected by changing a : for a second source the origin of the fringes is given by

$$q_0' = -v'a / (a - \{\beta \sin \theta' + \alpha \sin \theta\}).$$

and if the visible rectangles overlap, there will be a sensible diminution of the fringe appearance whenever

$$q_0 - q_0' = (n + \frac{1}{2})b\lambda/2 \{a - (\beta \sin \theta' + \alpha \sin \theta)\}$$

where n is an integer;

i. e. $v' - v = \text{an odd multiple of } b\lambda/4a,$

the condition previously found.

One further point should be noticed : if a be very nearly equal to $\beta \sin \theta' + a \sin \theta$ the fringes become too broad to be observed, whatever the source may be.

Fig. 5.

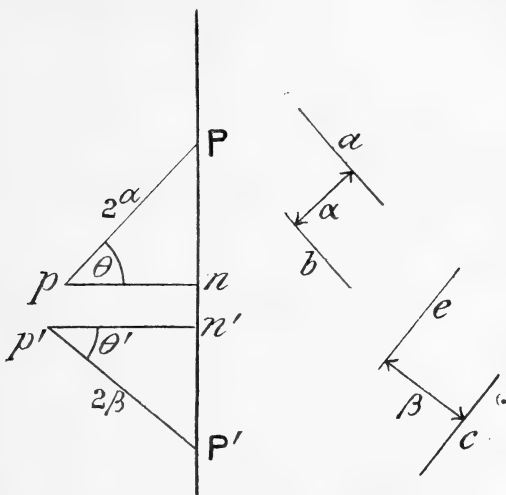

To see the physical meaning of this condition, and also of the condition $\beta \cos \theta' = a \cos \theta$, we notice that a point source of light P at the centre of one of the slits appears after reflexion at the two mirrors a, b , to be at p , where Pp is equal to twice the distance between the mirrors and is perpendicular to their plane (fig. 5). Hence the double reflexion removes the image of the slit a distance $2a \cos \theta$ behind the diaphragm and $2a \sin \theta$ closer to the centre. In the same way the image of the other slit is brought $2\beta \cos \theta'$ behind the diaphragm and $2\beta \sin \theta'$ nearer the centre.

Our condition $\beta \cos \theta' = a \cos \theta$ therefore means that the images of the two slits must be in the same plane parallel to the plane of the diaphragm itself, and our second condition shows that they must be some distance apart.

To find the minimum of this distance, remember that the fringes will be invisible if the distance between successive maxima exceeds the vertical dimension of the visible rectangle : in other words, if

$$b\lambda/2(a - (\beta \sin \theta' + a \sin \theta)) > b\lambda/k,$$

$$\text{or distance in question} < k,$$

which means that the centre of the image of either slit must

be outside the other. These two points must be carefully borne in mind in adjusting the instruments.

When this, however, is done, we see that Michelson's assertions are confirmed, and that when we increase the aperture of the telescope in this way, the results obtained are of the same character as when the slits are placed directly in front of the object-glass.

5. Let us now proceed to consider an extended source, which we shall suppose for simplicity to be of uniform intensity.

The intensity at a point (p, q) on the screen will be of the form

$$I = A^2 \frac{64h^2k^2}{b^2\lambda^2} \iint \left\{ \frac{\sin \frac{2\pi k(q+v)}{b\lambda}}{\left(\frac{2\pi k(q+v)}{b\lambda}\right)} \cdot \frac{\sin \frac{2\pi h(p+u)}{b\lambda}}{\left(\frac{2\pi h(p+u)}{b\lambda}\right)} \right\}^2 \cos^2 \frac{2\pi a(q+v)}{v\lambda} du dv,$$

the integral being taken all over the geometrical image of the extended source.

We have now three cases to consider.

- (a) When the angular dimensions of the source are large compared with λ/h .
- (b) When the angular dimensions of the source are small compared with λ/h .
- (c) When the angular dimensions of the source are neither large nor small compared with λ/h .

Let us begin with case (a). Then, if we consider a point inside the geometrical image, the two limits for u will be very large, except where the vertical through the point cuts the image; the quantity

$$\left\{ \frac{\sin \frac{2\pi h(p+u)}{b\lambda}}{\frac{2\pi h(p+u)}{b\lambda}} \right\}^2$$

being insensible for all points outside a thin strip (shaded in the figure) having for its central line the line through p, q perpendicular to the slits.

We may therefore, in integrating with regard to u , replace the limits by $\pm\infty$, and then integrate with regard to v along the chord of the image perpendicular to the slits.

Fig. 6.

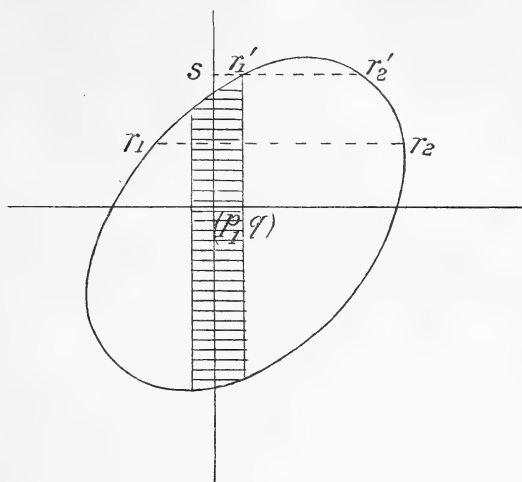

Hence, remembering that

$$\int_{-\infty}^{\infty} \frac{\sin^2 x}{x^2} dx = \pi,$$

it follows that

$$I = \frac{32A^2hk^2}{b\lambda} \int \left\{ \frac{\sin \frac{2\pi k}{b\lambda} (q+v)}{\frac{2\pi k}{b\lambda} (q+v)} \right\}^2 \cos^2 \frac{2\pi a}{b\lambda} (q+v) dv.$$

Now if the angular dimensions of the source of light be large compared with λ/k , the limits of integration with regard to v may be made infinite. In this case the intensity I

$$\begin{aligned} &= \frac{8A^2hk^2}{b\lambda} \int_{-\infty}^{\infty} dv \left\{ \sin^2 \frac{2\pi}{b\lambda} (a+k)(q+v) + \sin^2 \frac{2\pi}{b\lambda} (a-k)(q+v) \right. \\ &\quad \left. - 2 \sin^2 \frac{2\pi a}{b\lambda} (q+v) + 2 \sin^2 \frac{2\pi k}{b\lambda} (q+v) \right\} \div \left(\frac{2\pi k(q+v)}{b\lambda} \right)^2 \\ &= \frac{4A^2h}{\pi} \left[\{ (a+k) + (a-k) - 2a + 2k \} \int_{-\infty}^{+\infty} \frac{\sin^2 x}{x^2} dx \right] \\ &= 8A^2hk = \text{constant.} \end{aligned}$$

This result shows us that if the dimensions of the source exceed a certain limit, no diffraction-fringes exist at all, at least near the centre of the image. Next let the angular dimensions

of the source be less than $\frac{\lambda}{12k}$, then throughout the integration

$\frac{2\pi k}{b\lambda}(q+v)$ is less than $\pi/6$ numerically.

But

$$\frac{\sin^2 \frac{\pi}{6}}{\pi^2/36} = \frac{9}{\pi^2},$$

and differs but little from unity.

We may therefore in this case write

$$\frac{\sin^2 \frac{2\pi k}{b\lambda}(q+v)}{\left(\frac{2\pi k}{b\lambda}(q+v)\right)^2} = 1$$

throughout the range of integration.

If now the limits be v_1 and v_2 we have

$$\begin{aligned} I &= \frac{32A^2hk^2}{b\lambda} \int_{v_2}^{v_1} \left(\frac{1}{2} + \frac{1}{2} \cos \frac{4\pi a(q+v)}{b\lambda} \right) dv \\ &= \frac{4A^2hk^2}{\pi a} \int_{v_2}^{v_1} \left(1 + \cos \frac{4\pi a(q+v)}{b\lambda} \right) d\left(\frac{4\pi a(q+v)}{b\lambda} \right) \\ &= \frac{4A^2hk^2}{\pi a} \left\{ \frac{4\pi a}{b\lambda} (v_1 - v_2) + \sin \frac{4\pi a(q+v_1)}{b\lambda} - \sin \frac{4\pi a(q+v_2)}{b\lambda} \right\} \\ &= \frac{4A^2hk^2}{\pi a} \left\{ \frac{4\pi a(v_1 - v_2)}{b\lambda} + 2 \sin \frac{2\pi a(v_1 - v_2)}{b\lambda} \cos \frac{4\pi a(q + \frac{1}{2}(v_1 + v_2))}{b\lambda} \right\}. \end{aligned}$$

Let $2c$ = length of chord through the point perpendicular to the direction of the slits, then

$$2c = v_1 - v_2,$$

and let v_0 = coordinate of the mid-point of this chord. Then

$$I = \frac{8A^2hk^2}{\pi a} \left\{ \frac{4\pi ac}{b\lambda} + \sin \frac{4\pi ac}{b\lambda} \cos \frac{4\pi a(q+v_0)}{b\lambda} \right\}.$$

The fringes therefore disappear when

$$\frac{4\pi ac}{b\lambda} = s\pi.$$

Their visibility is

$$\sin \frac{4\pi ac}{b\lambda} / \frac{4\pi ac}{b\lambda},$$

and is a maximum when

$$\frac{4\pi ac}{b\lambda} = \tan \frac{4\pi ac}{b\lambda};$$

but the most visible fringes correspond to the early maxima.

This form agrees exactly with the formula given by Mr. Michelson for a uniformly illuminated segment of a straight line perpendicular to the slits. We see, however, that, provided the conditions stated be fulfilled, it is applicable to a source of any shape.

The most general form of the fringes is given by

$$q + \frac{1}{2}(v_1 + v_2) = \text{const.},$$

and therefore consists of lines parallel to the locus of middle points of chords at right angles to the slits. These will be straight lines in the case of a rectangular, circular, or elliptic source. Here, however, a new difficulty presents itself. For the rectangular source $v_1 - v_2$ will be constant, whatever chord perpendicular to the slits we may select. Fringes will therefore appear and disappear as a whole.

But for a circular or elliptic source, $v_1 - v_2$ varies as we pass from chord to chord. Thus the maxima will be invisible for some chords when they are most visible for others and conversely. Hence, whatever be the distance between the slits, it appears at first as if we might always expect a mottled appearance.

But in the case of a circular or elliptic source the length of the chord varies extremely slowly near the centre and there fringes will be visible, the length of the chord being practically constant. The mottled appearance, on the other hand, will predominate as we approach the sides.

6. Consider now case (b) and let the dimensions of the source be so small that, for any point sufficiently close to the centre of the image $\frac{2\pi h(p+u)}{b\lambda}$ is a small angle throughout the range of integration.

[For points not near the centre of the image the illumination will be very small and the appearances are comparatively unimportant.]

For a point distant $< \frac{\lambda b}{24h}$ from the centre of the image, we may put, as in previous reasoning,

$$\left\{ \frac{\sin \frac{2\pi k}{b\lambda}(q+v)}{\frac{2\pi k}{b\lambda}(q+v)} \frac{\sin \frac{2\pi h}{b\lambda}(p+u)}{\frac{2\pi h}{b\lambda}(p+u)} \right\}^2 = 1$$

all over the range of integration, whence

$$\begin{aligned} I &= \frac{32A^2k^2h^2}{b^2\lambda^2} \iint \left(1 + \cos \frac{4\pi a(q+v)}{b\lambda} \right) dudv \\ &= \frac{32A^2k^2h^2}{b^2\lambda^2} \left(\Omega + \cos \frac{4\pi aq}{b\lambda} \int u \cos \frac{4\pi av}{b\lambda} dv - \sin \frac{4\pi aq}{b\lambda} \int u \sin \frac{4\pi av}{b\lambda} dv \right) \\ &= \frac{32A^2k^2h^2}{b^2\lambda^2} \left(\Omega + R \cos \left(\frac{4\pi aq}{b\lambda} + \phi \right) \right), \end{aligned}$$

where Ω = total area of the image,

$$R \cos \phi = \int u \cos \frac{4\pi av}{b\lambda} dv, \quad R \sin \phi = \int u \sin \frac{4\pi av}{b\lambda} dv,$$

the integrals being taken all over the image. The visibility = R/Ω and therefore vanishes when R vanishes.

In the case of a circular source we find

$$\phi = 0, \quad R = (\text{some non-vanishing factor}), J_1 \left(\frac{4\pi ar}{b\lambda} \right),$$

where J_1 is the Bessel's function of order unity and r is the radius of the image, so that r/b is the angular radius of the source. The dark fringes are given by

$$\frac{4\pi aq}{b\lambda} = (2s + 1)\pi,$$

q being measured from the centre of the source. The fringes are parallel to the slits and disappear whenever

$$J_1 \left(\frac{4\pi ar}{b\lambda} \right) = 0.$$

This result agrees with the one given by Michelson for any circular source. We see that it only holds provided the dimensions of the source do not exceed a certain limit.

In the case of an elliptic source $\phi = 0$ also, and R is not altered by any sliding of the image parallel to the direction of the slits. Hence we may replace the oblique ellipse by one having its principal axis parallel and perpendicular to the slits, the values of the semi-axes being d and ϖ , where d = length of semi-diameter of original image parallel to the slits, ϖ = length of perpendicular from the centre upon the parallel tangent. We find without difficulty :

$$\begin{aligned}
 R &= \int \cos \frac{4\pi av}{b\lambda} u dv \text{ over the image} \\
 &= 4 \int_0^{\varpi} \frac{d}{\varpi} \sqrt{\varpi^2 - v^2} \cos \frac{4\pi av}{b\lambda} dv = \frac{d\varpi}{2} \cdot \frac{b\lambda}{a\varpi} J_1\left(\frac{4\pi a\varpi}{b\lambda}\right) \\
 &= \Omega \left(\frac{b\lambda}{2\pi a\varpi}\right) J_1\left(\frac{4\pi a\varpi}{b\lambda}\right).
 \end{aligned}$$

The visibility is therefore

$$2 J_1\left(\frac{4\pi a\varpi}{b\lambda}\right) / \left(\frac{4\pi a\varpi}{b\lambda}\right),$$

and vanishes whenever

$$J_1\left(\frac{4\pi a\varpi}{b\lambda}\right) = 0.$$

Hence we see that, for an elliptic source, if ρ = length of semi-diameter perpendicular to the slits, ϖ = length of perpendicular on the tangent parallel to the slits, then the fringes disappear when $\sin \frac{4\pi a\rho}{b\lambda} = 0$, if the angular dimensions are of order $\frac{1}{12} \frac{\lambda}{h}$ as indicated above, and when $J_1\left(\frac{4\pi a\varpi}{b\lambda}\right) = 0$, when the angular dimensions are less than $\frac{1}{12} \frac{\lambda}{h}$.

In the first case ρ is the quantity which determines the disappearance of the fringes, in the second case ϖ : and further, we see that the validity of the formulæ is entirely dependent on the *length* and *breadth* of the slit, neither of which is considered by Mr. Michelson.

We may notice that the best results are obtained, in the first case when h is large, in the second case when h is small.

7. It remains to consider the intermediate case (c). This does not perhaps present so much interest as the other two; the first will generally correspond to the case of a planet, the second to that of a star, in astronomical observations.

In dealing with case (c) we shall suppose the angular dimensions to be small, with regard to λ/k , but not with regard to λ/h . We may then write

$$\begin{aligned}
 I &= \frac{6 A^2 h^2 k^2}{b^2 \lambda^2} \iint \left\{ \frac{\sin \frac{2\pi k(q+v)}{b\lambda}}{\frac{2\pi k(q+v)}{b\lambda}} \cdot \frac{\sin \frac{2\pi h(p+u)}{b\lambda}}{\frac{2\pi h(p+u)}{b\lambda}} \right\}^2 \cos^2 \frac{2\pi a(q+v)}{b\lambda} dudv \\
 &= \frac{32 A^2 h^2 k^2}{b^2 \lambda^2} \iint \frac{\sin^2 \frac{2\pi hu}{b\lambda}}{\left(\frac{2\pi hu}{b\lambda}\right)^2} \left(1 + \cos \frac{4\pi a(q+v)}{b\lambda}\right) dudv,
 \end{aligned}$$

if we only consider the appearances along the line $p=0$, taken to pass through the centre of the image, which is assumed circular or elliptic.

Denoting $\frac{2\pi h}{b\lambda}$ by μ and expanding, we get

$$\frac{\sin^2 \frac{2\pi hu}{b\lambda}}{\left(\frac{2\pi hu}{b\lambda}\right)^2} = 1 - \frac{1}{2} \cdot \frac{2^2 \mu^2 u^2}{3!} + \dots + \frac{(-1)^{r-1} (2\mu u)^{2(r-1)}}{r \cdot (2r-1)!} + \dots,$$

whence

$$I = \frac{32A^2 h^2 k^2}{b^2 \lambda^2} \left[K + \int \left(u - \frac{1}{2 \cdot 3} \frac{(2\mu)^2 u^3}{3!} + \dots + \frac{(-1)^{r-1} (2\mu)^{2(r-1)} u^{2r-1}}{r(2r-1)!} + \dots \right) \times \cos \frac{4\pi a(q+v)}{b\lambda} dv \right]$$

where

$$K = \iint \frac{\sin^2 \mu u}{\mu^2 u^2} dudv$$

taken all over the source, and is essentially positive and independent of a and q .

Now

$$\int u^{2r-1} \sin \frac{4\pi a(v)}{b\lambda} dv = 0$$

for a circle or ellipse.

To find the cosine integral, C , we have, d and ϖ having the same meaning as before,

$$C = 4 \int_0^{\varpi} \frac{d^{2r-1}}{\varpi^{2r-1}} (\varpi^2 - b^2)^{r-\frac{1}{2}} \cos \frac{4\pi av}{b\lambda} dv.$$

Put $v = \varpi \cos \theta$.

$$\begin{aligned} C &= 4d^{2r-1} \varpi \int_0^{\frac{\pi}{2}} \sin^{2r} \theta \cos \left(\frac{4\pi a \varpi}{b\lambda} \cos \theta \right) d\theta \\ &= \frac{2d^{2r-1} \varpi 2^r \sqrt{\pi} \Gamma(r + \frac{1}{2})}{\left(\frac{4\pi a \varpi}{b\lambda}\right)^r} J_r \left(\frac{4\pi a \varpi}{b\lambda} \right) \\ &= \frac{2d^{2r-1} \varpi \pi (2r-1)!}{2^{r-1} (r-1)!} \frac{J_r \left(\frac{4\pi a \varpi}{b\lambda} \right)}{\left(\frac{4\pi a \varpi}{b\lambda}\right)^r}. \end{aligned}$$

Hence:

$$I = \frac{32A^2h^2k^2}{b^2\lambda^2} \left\{ K + \cos \frac{4\pi a q}{b\lambda} \left(\sum_{r=1}^{\infty} \frac{2\pi d}{(4\pi a \varpi)^r} (-1)^{r-1} \frac{\left(\frac{4\pi h}{b\lambda}\right)^{2r-2}}{r(2r-1)} \frac{J_r\left(\frac{4\pi a \varpi}{b\lambda}\right)}{2^{r-1}(r-1)!} \right) \right\}$$

$$= \frac{32A^2h^2k^2}{b^2\lambda^2} \left[K + 2 \cos \frac{4\pi a q}{b\lambda} \frac{\pi \varpi d}{\left(\frac{4\pi a \varpi}{b\lambda}\right)^2} \sum_{r=1}^{\infty} (-1)^{r-1} \left\{ \frac{\left(\frac{4\pi h d}{b\lambda}\right)^2}{8\pi a \varpi} \right\}^{r-1} \frac{J_r\left(\frac{4\pi a \varpi}{b\lambda}\right)}{r!(2r-1)} \right]$$

Denote by Ω the total area of the image and by e the ratio

$$\left(\frac{4\pi h d}{b\lambda}\right)^2 / \left(\frac{8\pi a \varpi}{b\lambda}\right).$$

Then the visibility

$$= \frac{2\Omega}{K} \frac{1}{\frac{4\pi a \varpi}{b\lambda}} \left\{ J_1\left(\frac{4\pi a \varpi}{b\lambda}\right) - \frac{e}{6} J_2\left(\frac{4\pi a \varpi}{b\lambda}\right) + \dots \right. \\ \left. + (-1)^{r-1} \frac{e^{r-1}}{r!(2r-1)} J_r\left(\frac{4\pi a \varpi}{b\lambda}\right) + \dots \right\}$$

The series for the visibility is absolutely convergent, because $J_{n+1}(x)/J_n(x)$ decreases numerically without limit as n increases without limit.

The roots of the equation

$$J_1\left(\frac{4\pi a \varpi}{b\lambda}\right) - \frac{e}{6} J_2\left(\frac{4\pi a \varpi}{b\lambda}\right) + \dots + (-1)^{r-1} \frac{e^{r-1}}{r!(2r-1)} J_r\left(\frac{4\pi a \varpi}{b\lambda}\right) + \dots = 0$$

give the values of a for which the visibility vanishes.

Notice, however, that e contains d and the length of the slit, so that the values obtained for a will be functions of the horizontal diameter and of the length of the slit.

8. Besides enabling us to determine the angular distance of two point-sources and the radius of an extended source, Mr. Michelson's method allows us to detect and measure the ellipticity of a luminous disk.

Referring to the formulæ for cases (a) and (b), the visibility vanishes when

$$\sin \frac{4\pi a \rho}{b\lambda} = 0 \text{ in case (a),}$$

and when

$$J_1\left(\frac{4\pi a \varpi}{b\lambda}\right) = 0 \text{ in case (b).}$$

In either of these cases, if we rotate the slits about the axis of the telescope, without altering a , then if the source is elliptic, ρ and ϖ will vary, and the visibility of the fringes will vary.

Now suppose for a given position of the slits we vary a until the visibility = 0 for that position, and then rotate the slits and note the different inclinations for which it vanishes.

It will certainly vanish once again before a complete half-turn has been made, namely, when the slits make an angle with the direction of either axis of the ellipse equal to that which they made at first, but on the other side of the axis.

It may vanish more than once, but since the inclinations for which it vanishes are symmetrical with regard to the axes of the ellipse, there will usually be no difficulty in determining the *directions* of the axes.

Their *lengths* can then be determined by two observations of the disappearance of the fringes, one for each of the two positions of the slits which are perpendicular to an axis.

It must, however, be noticed that the accuracy of this method for measuring ellipticity decreases with the size of the source, inasmuch as the quantity which causes the alteration in the fringes is the *difference*, not the *ratio* of the semi-axes.

To get some idea of the sensitiveness of the method, let us estimate roughly the amount of ellipticity which could be detected in a disk of angular semi-diameter $10''$, taking the mean wave-length of light $\cdot 5 \times 10^{-4}$ cms.

The visibility vanishes when $\sin \frac{4\pi a \rho}{b\lambda} = 0$, and will be quite sensible when $\sin \frac{4\pi a \rho}{b\lambda} = \frac{1}{2}$, say. Hence in order that we may be able to note a sensible difference of visibility in the fringes, we must have

$$\frac{4\pi a}{\lambda} \left(\frac{\rho_1 - \rho_2}{b} \right) = \frac{\pi}{6} \text{ at least;}$$

or

$$\frac{\rho_1 - \rho_2}{b} = \frac{1}{2} \frac{1}{10^6}$$

if a be a little above 4 cms.

\therefore difference of angular semi-axes = $\cdot 01$ (semi-diameter) $g.p.$, or the amount of ellipticity which can be detected = $\cdot 01$.

I have taken $\sin \frac{4\pi a \rho}{b\lambda} = 0$ as giving zero visibility, because this example will clearly fall under case (a).

9. Summing up the results obtained we see that :—

(1) It is possible by the observation of Michelson's interference-fringes to separate a double point-source, or detect breadth and ellipticity in a slightly extended source.

(2) But the distance between the two points, or the dimensions of the extended source, must lie within certain limits depending on the length and breadth of the slits*.

(3) The dimensions of the slits also considerably affect the general theory, the formulæ obtained not being identical with Michelson's. The law of appearance and disappearance of the fringes depends very largely on the distance between the points or the dimensions of the extended source.

XLII. *The Absorption of Water in Hot Glass.* Second Paper.
By CARL BARUS †.

1. **A**FTER finishing my account ‡ of the action of hot water on glass, observed in fine-bore capillary tubes, it seemed to me that the experiments made several years ago (1891) left questions of considerable interest outstanding. I refer in particular to a further examination of the contents of the capillary tubes. Certain evidence was to be obtained as to the occurrence of syrupy glass at 185°, solidifying to a firm glass when cold, the composition remaining unchanged except as to the water absorbed. Again, as it was improbable that volume-contraction would continue at the same rate indefinitely, the conditions of subsidence were to be determined, together with the effect of the elastic and viscous constants of the tube itself on the apparent volume contractions and compressibilities observed. Questions relative to the acceleration of the reaction at higher temperatures were to be held in view.

Finally, if the inferences drawn from data for capillary tubes are correct, it should be possible to obtain the fusible glass on a larger scale. Experiments in progress in this direction have proved quite successful, and will be described in a later paper. The present remarks are restricted to the experiences with capillary tubes.

2. The apparatus used was the same as that heretofore

* Since the above was read, a paper has appeared in the *Comptes Rendus de l'Académie des Sciences* for Nov. 28, 1898, dealing with the modifications in Michelson's formulæ when we take into account the breadth of the slits. The author, M. Hamy, follows Michelson in not considering variations of intensity parallel to the slits. This, I think, accounts for his results not quite agreeing with mine.

† Communicated by the Author.

‡ *Phil. Mag.* (5) xlvii. p. 104, Jan. 1899.

described (*l. c.*), a clear thread of water being enclosed in a stout capillary tube between terminal threads of mercury, the upper of which was sealed in place, while the lower transmitted the pressure of a force-pump. The motion of each meniscus was observed in the lapse of time through a clear boiling tube (vapour-bath, 185° to 210°) with the cathetometer.

The progress of the experiments may be described, as a whole, as follows:—During the first stages of heating the clear thread of water expands, inasmuch as the constant temperature in question is being approached. After this an initially rapid contraction of the thread is manifest, which must have begun much before the period of constant temperature was reached, so that the full thread-length for 210° is never quite attained. During the early and most marked period* of contraction (and some time before) the tube appears white and opaque, and the observer can only with difficulty follow the rise of the lower mercury meniscus. The top meniscus remains in place. Compressibility is a rapidly increasing quantity. During the later stages† of heating the tube becomes transparent again, the mercury-threads stand out brilliantly, and the whitish opaque matter gradually vanishes in the axis of the tube. Contraction becomes less marked and finally ceases; and with it the accentuated compressibility of the aqueous silicate, now so thickly viscid as to retain cavities, also disappears. During this second stage, threads of mercury invariably break off if there is change of pressure. Nevertheless, measurement by means of these indices is not impossible, and in the telescope the observer notices a slow advance of the viscous mass, moving *as a whole* continually towards the upper end of the tube and carrying the little mercury globules along like debris in a common current.

To measure compressibility at this stage is to face a dilemma: on increasing pressure from below, there is marked increase in the upward motion of the viscous current. It is difficult to state when this accentuated motion ceases. On removing pressure the mercury does not retreat proportionately, if at all. However, when pressure is reduced too far, the mercury may retreat several centimetres, quite out of the field of view, as a whole, leaving well rounded or ovoid cavities behind. Thus it is impossible to make measurements

* Undissolved glass coagulum.

† Dissolving coagulum

for compressibility in triplets, and the data are given below with this reservation. These data accentuate the absence of effective volume elasticity under the conditions stated.

When the viscous thread has appreciably ceased to contract (1-2 hours), and the tube is allowed to cool very carefully, *bubbles* make their appearance very much resembling those in a Prince Rupert drop, and probably due to a similar cause*. They begin to form in the axis, and are usually connected by a fine channel. They may grow to a diameter of over $\frac{2}{3}$ the width of the bore. The formation of these bubbles on cooling is proof that the aqueous silicate is still liquid at the temperature of the vapour-bath (185° - 210°), however viscous and incompressible it may have become. The solidifying core of water-glass contracts from the centre outward, and must contract more rapidly than the igneous-glass envelope. It is this last stage (contents cleared again to a pellucid jelly) which I failed to fully observe in my earlier experiments, believing that solidification had set in when the mercury-threads broke off.

After the tube has passed the final stage with subsidence of contraction, it invariably breaks throughout its length when cold, in such a way as at first sight to suggest expansion on solidification of the aqueous silicate within. It makes no difference how carefully the cooling is performed. If a thread of fusible metal is allowed to solidify in a capillary tube, the latter breaks sooner or later in the same way. I do not by any means imply that the aqueous silicate does actually expand on solidifying, for there are other and better ways in which the breakage can be explained. The appearance of bubbles, for instance, is evidence of contraction, and the breakage is rather due to an excessively shrinking core.

When the cold tube is cut across, the core of water-glass practically fills the tube, and to all appearances is as hard, clear, and firm as the igneous glass surrounding it. There is a difference of refraction between the two glasses sufficient to make the aqueous core apparent under favourable illumination; but for this and the bubbles, the tube would be undistinguishable from a glass rod.

If, however, the end of the glass tube is slightly heated above a candle-flame or a small bunsen-flame, the core soon begins to melt, to swell up enormously in bulk as the result of the frothing which accompanies the escape of steam. The

* It is to be remembered, however, that whereas the Rupert drop is cooled down from above 1000° C., the present high temperature is only about 200° .

result is a light, very white pumice, largely exuding from the capillary canal (as shown in fig. 1), the part remaining within resembling pith. In this way the enlarged bore of the tube may be clearly compared with the parts left free

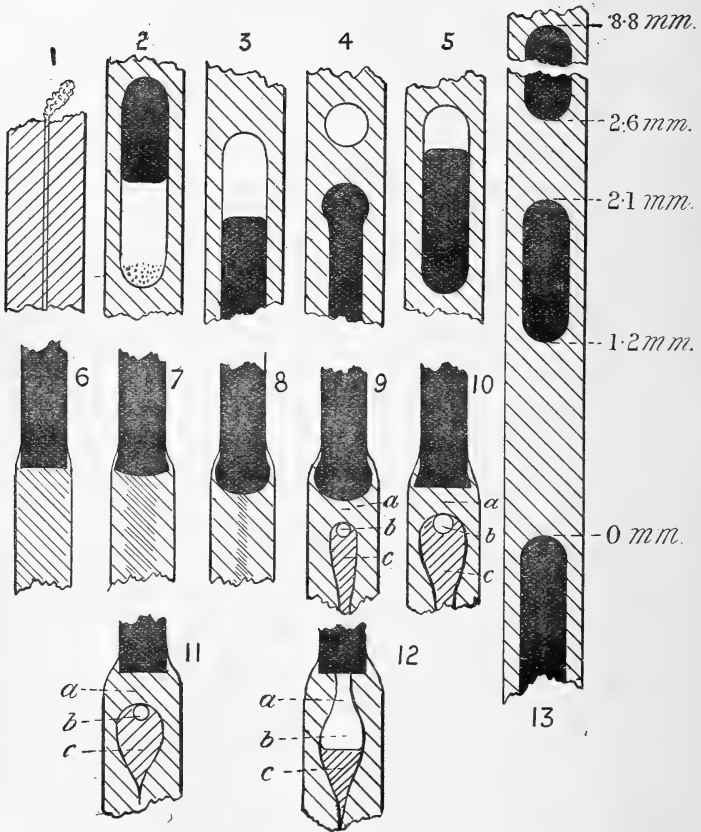

Fig. 1.—Capillary tube, with water-glass core heated above.

Figs. 2-13.—Diagrams. The cross-hatched parts denote the core of water-glass (much enlarged), the envelope of igneous glass being ignored. Mercury is shown in black; cavities in white; residual water (?) is differently cross-hatched. The actual contours were usually more ovoid than these figures.

from water and in contact with mercury only. On further fusion the pumice melts igneously, and, if the glass contains lead, it turns black in the usual way on reduction.

There is good reason to suppose that the aqueous silicate remains homogeneous from the time of incipient solution to the eventual occurrence of a viscous glassy coagulate, liquid enough at 200° to admit of the formation of internal bubbles on cooling and contraction, but at the same time viscous enough to keep similar bubbles in shape and position without cooling. A thin thread of water (.01 to .04 centim. in diam.) is undergoing lateral diffusion into the glass, and concentration difference is virtually confined to the cylindrical surface of contact between igneous glass and water-glass, widening as the action goes on so slowly, that the much more liquid water-glass is free to remain homogeneous. The latter should therefore be identical in composition with the original glass, but for the incorporated water.

In a final experiment (tube No. 7) I put a solution of cobalt nitrate into the tube, rather with the expectation of finding *blue* water-glass as the result. No such action occurred; instead of it, the water diffused into the glass as usual and the cobaltic nitrate was left as a granular scum in the axis. Chemical decomposition and incorporation of the cobalt did not therefore occur at 200°.

3. Instead of tabulating the large number of observations made (in all seven tubes were employed), it will conduce to clearness to present the work graphically. In so doing, the data for the former tubes may be included, for reference. Time is laid off in intervals of 20 minutes (between vertical lines) along the abscissas, while the ordinates indicate the changes of length of the column of water in intervals of 1 centim. It is not convenient to specify the full length of the thread in the chart; but a datum for the length of the cold thread at about 20°C. will be given both in the latter and in the tables containing original and final bore, and similar specifications for each capillary tube. These diameters were measured with the cathetometer, the tubes being cut across and looked at endwise. Slight heating increased the sharpness of definition between the original glass and the solid core of water-glass within.

The chart also contains the mean compressibilities β , for pressure intervals of about 100 atm., no attempt to obtain β as a function of pressure being made for the reasons stated in § 2. Since $\beta = (v/V)/p$, or the decrement of volume per unit of volume per atmosphere, or practically decrement of length per centim. of column per atmosphere, the abscissas as above are successive time-intervals of 10 minutes each, while the scale of ordinates is a change of β of .000100. Several

β -values are usually attached to the compressibility-curves for orientation.

Calling the two capillary tubes formerly used (preceding paper, l. c.) Nos. 1 and 2, their dimensional constants before and after corrosion were as follows :—

	Internal diameter (centim.).		Section.		Cold thread- length.
	Original.	Corroded.	Original.	Corroded.	
No. 1	·043	·052	·0015	·0021	18·4 cm. at 28°
No. 2	·042	·051	·0014	·0023	14·0 cm. at 24°

In these cases the temperature of the vapour-bath was but 185°, and the corrosion did not outrun the opaque stage. Seen under the microscope, the solid water-glass nearly filled the bore, being an opalescent warty accretion. The chart (p. 470) contains the results for decrement of length of thread and of compressibility so far as observed, after constant temperature had set in. In all these experiments β is thoroughly determined* from at least four measurements between 20 and 400 atm., the initial lengths of thread returning on removal of pressure.

In case of No. 1, time was not observed until after nearly an hour's boiling. The short curves thus refer to the end of the experiments. The general conclusions are stated in the preceding paper.

4. The first of the new tubes to be heated was No. 3, with the following constants :—

Temperature of Vapour-bath, 185°.		
Internal diameter (cm.).	Section.	
Original	·0295	·00068
Corroded	·0415	·00135
		Cold thread-length 17·4 cm. at 23°.
		External diameter about ·3 cm.

The observations with this tube were not satisfactory; possibly the temperature of the vapour-bath was insufficiently constant; possibly the clear stage of reaction is not reached at 185° (*cf.* §12). The tube turned opaque and so remained. The fouled meniscus was frequently lost, or could not be

* *Cf.* Am. Journ. Sci. xli. p. 110 (1891).

recognized with certainty. No observations were possible until after 30 minutes' boiling.

In the absence of systematic data, however, certain incidental results of interest were obtained with this tube, by observing at high and low temperatures alternately. Thus, after about an hour's boiling, β fell off from $120/10^6$ at 185° to about $40/10^6$ at ordinary temperatures. After about $2\frac{1}{2}$ hours' boiling, β fell off from about $230/10^6$ at 185° to $90/10^6$ at ordinary temperatures. After about four hours' boiling the hot compressibilities reached $400/10^6$; but the tube broke before the corresponding cold compressibilities were measured.

Opportunity was also afforded for roughly measuring the coefficients of expansion of water-glass. After two and a half hours' boiling the mean coefficient per degree was about $\cdot 002$, between 25° and 185° C. The corresponding mean coefficient for pure water, according to Mendeléef *, is $\cdot 0008$ to $\cdot 0009$.

Thus it appears that even the relative contraction of water-glass is over twice as large as the normal value for water under like conditions. After four hours' boiling another measurement of the coefficient of expansion of water-glass gave nearly the same result as before. This coefficient did not, therefore, keep pace with the increase of β ; but, as only a small part of the thermal contraction on cooling lies in the region of high temperature to which β refers, the two coefficients should not keep pace.

Finally, a comparison between β and volume-contraction in the lapse of time showed a change of β of about $18/10^6$ for each per cent. of volume-contraction relative to the cold volume at 20° C. This mean rate is more rapid than the rate observed for tubes 1 and 2, or the following tubes.

5. The next tube examined was No. 4, with the following constants :—

Temperature of Vapour-bath, 210° .

Internal diameter (cm.)	Section.	
Original $\cdot 0240$	$\cdot 00045$	Cold thread-length 15.43 cm. at 20° .
Corroded $\cdot 0710$	$\cdot 00396$	
		External diameter, $\cdot 55$ cm.

A higher temperature of exposure (210°) was here chosen for comparison, in order to bring the corrosive action of the

* Phil. Mag. (5) xxxiii. p. 108 (1892).

water on glass to an actual period of subsidence, should this be possible. The aqueous silicate obtained was a clear hard core, plainly demarcated from the igneous glass envelope by difference of refraction, but otherwise not readily distinguishable from it. The bubbles contained no water. They were probably partial vacua with traces of steam. A fine axial canal, less than $\frac{1}{10}$ millim. in diameter, ran apparently through the water-glass core, threading the bubbles. The column of water shortened at 210° to its original length in the cold tube, after about 20 minutes of exposure. The transparent stage was reached in this tube earlier than usual, even at 210° . Indeed, the solvent action was energetic throughout, as is evidenced by the rapid volume-contraction. The chart gives the successive values of volume and compressibility (β) in the lapse of time. The quantity β is an estimate, since observations in triplets could not be obtained, increase of pressure corresponding to an increment in the continued volume-contraction.

Boiling began at $2^{\text{h}} 40^{\text{m}}$, and constant temperature* was reached at $2^{\text{h}} 55^{\text{m}}$. Pronounced volume-contraction had set in before this. The lower meniscus was lost as such before $2^{\text{h}} 60^{\text{m}}$. On increasing pressure the column ascended in form of a succession of ovoid drops with constrictions between them, the mercury diameters being smaller than the bore. Removal of pressure frequently separated these drops altogether, the viscous glass flowing in between them. Indeed the mercury often retreated in such a way as to leave the cavity half empty. In figure 2 (p. 464) I have drawn an interesting case observed at $3^{\text{h}} 3^{\text{m}}$. The mercury fills only the top half of the cavity left on reducing pressure. Very soon after the metal was seen falling to the bottom in a rain of very small drops. Since the diameter of the cavity did not exceed $\frac{1}{3}$ millim., the extreme fineness of these drops is remarkable even at 210° . On slightly increasing pressure again everything was seen to move upwards in a regular current, meniscus (below), detached mercury drops and threads, and the cavities. At $3^{\text{h}} 20^{\text{m}}$, the mercury still showed increased advance on raising the pressure to about 100 atm.; but on withdrawing pressure the mercury did not retreat. I measured the large compressibility $\beta = .000440$ for these conditions. Even at $3^{\text{h}} 30^{\text{m}}$ cavities half filled with mercury were much in evidence. At $3^{\text{h}} 50^{\text{m}}$ the column of aqueous silicate was nearly clear and continuous, and the compressibility now measured was found enormously reduced, perhaps less than the normal compress-

* See Chart (p. 470), curve No. 4, for time and length increments, &c.

sibility of water at 210° . After this, the action of water on the glass seems to have ceased, no further contraction occurred even up to $4^{\text{h}} 40^{\text{m}}$, when the tube burst at 100 atm.

The chief result obtained from this tube is therefore the certain evidence of an eventual subsidence of the reaction of the water on the glass under given circumstances. The rapidity of reaction, the occurrence of *floating* cavities partly full of mercury, partly of steam (?), the gradual reabsorption of this steam (?) by the glass on increasing pressure, are to be noted. During the continued volume-contraction compressibility β increased rapidly at first, reaching a maximum, and then fell off rapidly to the probable normal value for water at 210° , with the subsidence of further volume-contraction.

From my recent experiments on the compressibility of coagulated colloids*, I infer that the water-glass has now reached a similar stage. A convex meniscus forced upward by pressure changes to a conoid with apex sharpened upward. Removing pressure restores the convex form. Hence the column now possesses definite rigidity, and its viscosity requires long intervals of time to be put in evidence. Sharp axial lines, .05 millim. in diameter, true canals, together with bubbles strung on them like beads, were left after cooling. The axial lines are present at 210° , and then appear as the last vestige of the opaque or granular stage which precedes the clear stage. If there is really something granular about the former, and if the contraction of volume is a cementation of these granules into a homogeneous clear column of aqueous colloidal silicate, then the large final compressibilities are in a measure accounted for; but the compressibilities for tubes 1 and 2 are real in so far as all observations were made in triplets, and the fiducial zero was regained after high pressures (400 atm.). The granular hypothesis is thus quite inadmissible even if the interstices between the granules were supposed to contain non-saturated steam; for pressures increasing to above 400 atm. would soon wipe out the maximum vapour-tensions of 11-12 atm. at 185° , and less than 20 atm. at 210° .

At the close of the experiment the diameter of the mercury thread seemed to be somewhat over one half that of the core of aqueous silicate. Since the bore increased from .24 to .71 millim., the mercury thread did not thicken much on moving up.

A comparison of compressibility β and volume-reduction

* Am. Journ. (4) vol. vi. p. 285 (1898).

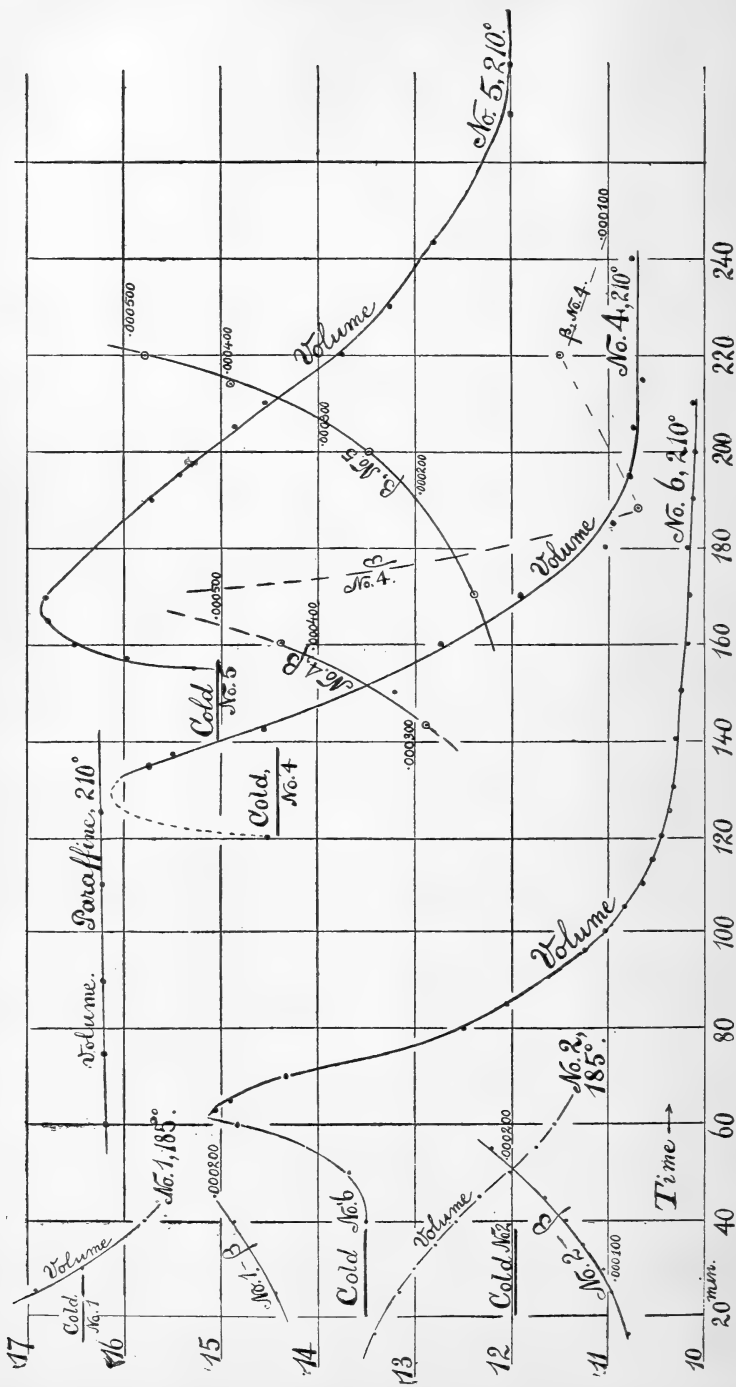

Chart.—Variation of Volume and Compressibility (ψ) in the lapse of time, in cases of Tubes Nos. 1, 2, 4, 5, 6.

(v/V) for tube No. 4 gave the following interpolated mean values :—

Thread-length (210°)....	16·0	14·5	13·6	12·0 cm.
$\beta \times 10^6$	260	350	440	70

The final datum marks the subsidence of the whole phenomenon, the β being nearly the normal datum for water (the usual case of colloids, which retain the compressibility of the solvent), and further volume decrement vanishing. During contraction the mean rate of β change is 80×10^{-6} per linear cm. of contraction. Since the initial cold length was 15·5 cm., this amounts to about 12×10^{-6} for each per cent. of volume decrease relative to the cold volume. This result agrees fairly well with the data for tubes 1 and 2.

6. The experiments with the next tube, No. 5, were in the main a corroboration of the results for tube No. 4. The bore was chosen larger.

Temperature of Vapour-bath, 210°.

Internal diameter (cm.).	Section.	Cold thread-length 14·05 cm. at 20°.
Original	·0085	
Corroded	·0260	External diameter, ·65 cm.

The chart shows the march of volume and of compressibility in the lapse of time. As a whole the reaction is slower than in § 5 ; the thread is shortened by contraction at 210° to its length for the cold tube in about 40 minutes, twice as long an interval as before.

Boiling began at 10^h 25^m, and constant temperature was reached about 15 minutes later. The observations as a whole are the same as in the preceding case. At 11^h 15^m the silicate failed to retreat with the advanced mercury column on removing pressure. A peculiar result was observed, as the mercury here ran down several centims., leaving the water-glass full of oval cavities, and afterwards ascended of its own accord to fill them again without manual interference at the force-pump.

I presume that pressure was reduced below the vapour-pressure of the water absorbed in glass ; that the temperature of the oil in the force-pump was thermodynamically reduced by expansion of the oil ; that the latter gradually regained its temperature, θ , by conduction, increasing the pressure in the hermetically sealed barrel. Since $d\theta/dp = \alpha v\theta/Jc_p$, a liquid of low specific heat c_p , low density $1/v$, and large thermal expansion α , contributes to this result.

The continuous, very slow contraction current toward the top of the tube was a marked feature. At 12^h 20^m pressure increment merely produced marked acceleration in the velocity of this current, removal of pressure leaving the mercury in place. On reducing pressure below a certain value, however, the mercury retreated quite out of the cavities, as above, to refill them again in the lapse of time. Figure 3 (p. 464) gives a view of a partially emptied cavity of this kind. In figure 4 a globular empty cavity formed during this process is shown, which was made to vanish symmetrically to a point over an advancing mercury meniscus.

The absorption of water in tube 5 virtually subsided after about two hours of boiling. In the fine-bore tube, § 5, like subsidence set in after but one hour of reaction. Differences of chemical composition are not excluded.

On cooling, bubbles appeared in homogeneous parts of the thread, throughout its length, spontaneously, and expanded often to over half the diameter of the core of water-glass. Moreover, ovoid cavities filled with mercury when hot are found partially empty after cooling, as shown in fig. 5, due to the contraction outward of the walls. The final breakage of this tube was *confined to the core*, which split across axially, allowing the mercury to enter as a thin sheet without breaking the envelope of igneous glass.

The relations of β and (v/V) for this tube may be stated from the following interpolation:—

Thread-length (cm.) at 210° ..	15.8	15.4	14.8	14.2	13.6	12.8
$\beta \times 10^6$	140	160	200	250	340	440

Compressibility increases at an accelerated rate with contraction. Leaving out the final very large values, the mean rate is 93×10^{-6} per centim. of contraction. As the cold length of thread is about 14 centim., this is a change of β of about 13×10^{-6} for each per cent. of volume-contraction referred to the cold volume. The result is thus again of the same order as the data from tubes 1, 2, and 5.

7. The tube No. 6 was observed specially for volume-contraction, its large bore not being adapted for β -measurements. The tube when cooled down after corrosion showed a fine, empty, axial canal, about .0063 centim. in diameter, left in the core of aqueous silicate and forming a channel of communication between fourteen large axial bubbles, distributed with fair uniformity along the length of the core. The constants of the tube were (vapour-bath at 210°)

Internal diameter (cm.)	Section.	Cold thread-length
Original..... ·0526	·0022	13·5 cm. at 20°.
Corroded ·1250	·0119	External diameter ·68 cm.

The march of volume-contraction is given in the chart. Boiling began at 9^h 50^m and the temperature was constant 5^m or 10^m later ; but contraction must have set in long before this. At 10^h 15^m the thread appeared indistinct and broken, marking the opaque period. At 10^h 30^m, though the water-glass was still granular, the mercury column, now about two-thirds the diameter of the hydrated core, became clearly manifest. At 10^h 55^m it stood out brilliantly; the granulations had retreated toward the axis, where they shone on illumination like a white cloud. In fig. 13 a group of mercury threads is given specially measured as to their distance apart. They moved bodily across the crosshairs of the telescope, keeping their position relatively to each other. This seems to be positive proof that the whole internal column is moving upward in consequence of contraction and is followed by the mercury meniscus moving in the direction of constant pressure. In so viscous a mass, a current up in the middle and down at the sides of the bore of about $\frac{3}{4}$ millim. is out of the question.

The deformation of the top of the column of water-glass in this experiment was striking, and is given in successive stages in figs. 6 to 12, showing its relation to the fixed (upper) mercury meniscus. In fig. 6 the water-glass is opaque and granular ; in fig. 7 the granular column is shrinking ; in fig. 8 granulations have vanished except in the axis. In fig. 9 the clear water-glass at *a* shows a steam (?) cavity at *b*, above the residual water (?) at *c*. This deformation may be regarded as an axial opening of the core due to contraction outward. Figures 10 and 11 show successive gradual changes of form of *b*, *c* in fig. 9, suggesting an upward march of pressure. Fig. 12 finally shows the gradual deformation of fig. 11, as the result of cooling ; but the mercury did not fall down into the channel of fig. 12, which here terminates in the upper meniscus. The expansion of the bubble *b* is the marked feature. Cooled with great caution, the tube nevertheless broke spontaneously ; parts of it after twelve hours, other parts even after months. No liquid water was detected in the cold tube, and the mercury ran freely through the channel in fig. 12. The large rate of reaction is an anomalous feature in view of the large diameter. Cf. curves 4, 5, 6 of chart.

The final tube No. 7, containing a solution of cobaltic

nitrate, has already been mentioned. The water-glass was not coloured blue, but the salt rejected as a scum in the axis of the tube. Hence the solution appears to be colloidal. In other respects the preceding phenomena were all reproduced, all incisions of the mercury column indicating a current upward in the direction of pressure. Compressibilities were obtained as high as $\beta = 400 \times 10^{-6}$.

8. If the uncertain result for the opaque tube 3 be excepted, the above comparisons of compressibility and volume-contraction as a rule contain data similar to those which corresponded to tubes 1 and 2, viz.—

No.....	1.	2.	3.	4.	5.
$\delta\beta \frac{\delta L}{L_0}$	11×10^{-6}	11×10^{-6}	18×10^{-6}	12×10^{-6}	13×10^{-6}

where $\delta\beta$ is the mean change of compressibility corresponding to the change of length δL , and where L_0 is the length of the thread when cold (used throughout for want of an available datum at the high temperatures). In view of the difficulty of measuring β , and of the later stage of reaction for which Nos. 3, 4, 5 apply, the results may be looked upon as of the same order and as a corroboration of Nos. 1 and 2.

Since the values β are apparent compressibilities, the association of values of β and volume-contraction may well be looked upon with suspicion: for as the capillary tube during the progress of the reaction increases continually in bore, or in other words is growing less thick-walled, it must at a given pressure yield more and more, and at the same time show continually increasing apparent compressibilities of the contents. A plausible explanation of the correlative variation of β and v/V is thus suggested. That it does not hold may be shown as follows:—

To treat the elastic problem first, Tait's equation* for the volume increment of hollow cylinders per unit of volume is available for computation. The true compressibility β_0 thus appears as

$$\beta_0 = \beta - \delta\beta = \frac{1}{p} \left(\frac{\delta L}{L} - \frac{\delta v}{v} \right) = \beta - \frac{a_0^2}{a_1^2 - a_0^2} \left(\frac{1}{k} + \frac{a_1^2}{a_0^2} \frac{1}{n} \right),$$

where p is the internal pressure, a_0 and a_1 the internal and external radius of the tubes, k the bulk-modulus, and n the rigidity of the glass. Thus it suffices to find the correction $\delta\beta$ for the original and the corroded tube in order to estimate the value of the elastic discrepancy in question. The follow-

* 'Challenger Reports,' 1882, Appendix, p. 29.

ing table contains the results, taking Everett's data (Tables) for k and n :—

Tube No.	1.	2.	3.	4.	5.	6.
Original bore $\delta\beta \times 10^6 =$	4.2	4.2	4.2	4.2	4.2	4.2
Corroded bore..... $\delta\beta \times 10^6 =$	4.3	4.3	4.2	4.3	4.2	4.4

Thus the mean effect of the enlargement of bore, due to internal corrosion, is at ordinary temperatures but $\cdot 000\ 0001$ in the extreme case, or only a few tenths per cent. of the value of β for cold water. As an explanation of the changes of β obtained, which run as high as 600 per cent., the elastic discrepancy is thus out of the question*.

The effect on the volume-contraction, being $\delta\beta.p$, would be in like degree negligible.

Finally, according to Amagat † the increase of compressibility of ordinary glass between 0° and 200° C. is about 5.9 per cent. Hence even at 200° the elastic discrepancy will be in almost the same degree negligible as at ordinary temperatures.

In experiments like the above, tubes which initially withstood 400 or 500 atmospheres, after prolonged straining will break even at 100 atm. or less. This result is rather to be ascribed to the fatigue of elasticity or to molecular strains imparted during cooling ; for it is not unusual when corrosion is altogether absent.

9. The next point at issue relates to the viscosity of glass at 200° . In a tube subject to viscous deformation the current towards the top may be regarded as the result of viscous stretching due to internal pressure. Increased β then represents the initially increased viscous yield accompanying the increased stress, the yield vanishing asymptotically in the lapse of time.

Reasons against this assumption are again of a quantitative kind. When the elastic deformations are not of serious consequence, the viscous changes are apt to be less so. Moreover viscous phenomena would not vanish in one hour as fully as the curves for tubes 4, 5, and 6 indicate. Finally, in a very large number of experiments in which hydrocarbons

* For experiments in a like direction, see my paper in *Am. Journal*, (3) xxxix. p. 485 (1890).

† *Notices sur les Travaux Sc. de M. E.-H. Amagat*, Paris, 1896, p. 36.

were subjected to much more intense pressures (400 atm.) even at 310° in capillary tubes, I never noticed volumetric evidence of viscous deformation comparable to the above. Add to this the appearance of the tube; *i. e.*, the passage from an opaque corroded interior gradually to a homogenous limpid jelly at the conclusion of the experiment, in parallel with the observed volume changes subsiding in a clear tube, and with the march of compressibility through enormously accentuated values, terminating in the relatively small values for hot water. Finally, after volume-contraction ceases (saturation) there is no further viscous response to any pressure excess whatever.

Viscosity is therefore not available to account for the volume-contraction observed. To make quite sure a special experiment was made with a thread of paraffin, 18.19 centim. long, at 210° and about 100 atm. After more than an hour's heating (observed 65 min.) the thread had gradually *increased* in length to 18.23 centim., due no doubt to the gradually rising temperature of the vapour-bath. The data given on the chart (curve marked paraffin) show that there is no relation between the present experiments and the behaviour of water.

10. I therefore regard it as established that the observed volume-contractions are real. The endeavour may now be made to compute limits for the density of the water-glass. Two ways suggest themselves: (1) By comparing the initial volume of igneous glass and water with the final volume of water-glass within the same bore (limit of corrosion); (2) By making allowance for the advance of the thread of mercury into the column of water-glass. I made these computations for all the tubes; but as the reactions in Nos. 1, 2, 3 are incomplete, Nos. 4, 5, 6 only need be given. The first method in these cases gave 3.4, 3.0, 3.5 respectively as the density of solid water-glass. This is obviously a superior limit seeing that the thread does not contract as a whole. The density of the igneous glass is but 2.46. The second method gave me 2.40, 2.25, and 2.35 respectively as the densities of the water-glass in the three cases. These data present an inferior limit (since the thread of mercury widens in advancing through viscous glass and since the full length of contraction cannot be observed), just as the preceding data are a superior limit. Hence the density of water-glass cannot differ very much from the density of igneous glass (2.46). Though the two sets of data differ widely, one may estimate the volume-contraction from their mean value to be about 20 per cent. of the combined volume of igneous glass and water, for complete subsidence of the reaction.

I may here refer to the apparent expansion on solidification, and the eventual breakage of tubes spontaneously. In a general way, this means an effectively different coefficient of expansion for the igneous glass without, from that for the water-glass within. Such a result could be brought about, for instance, if latent heat is set free by the water-glass on solidification: for the water-glass is nearly incompressible when solid, and the case would therefore be far different from the solidification of such relatively compressible bodies as paraffin in capillary tubes.

The characteristic formation of bubbles is evidence against expansion on solidification. Indeed I am not sure whether even an excessive contraction of the core may not start an internal crack in the water-glass which thereafter spreads into the igneous glass. Cracked water-glass cores with a sound envelope of igneous glass were a frequent occurrence. Finally, the congealed water-glass in the cold may tend to resume its volume before the volume-contraction was impressed by spontaneous decomposition. The definite decision can be made only when water-glass has been obtained on a larger scale.

12. Tubes 4, 5, 6 show conclusively that the action of water on glass ceases after the solution has reached a certain degree of concentration; compared with tubes 1, 2, 3, they show that the rate of reaction increases in marked degree with rise of temperature. These observations are in favour of the occurrence of a definite limit of saturation* or even of a definite chemical compound. Reaction, *cet. par.*, ceases with its formation. The marked contraction of bulk as the reaction proceeds may be adduced in favour of the chemical view, since in colloidal solution the volume phenomena are usually secondary.

It is to be noted that, apart from saturation, a gradual subsidence of the rate of reaction would be the result of ordinary colloidal solution, if the concentration gradient at the surface of contact of the water-glass core within and the igneous glass envelope without decreases as more glass enters into solution. The retention of the original composition of the glass with water added, the bodily rejection of colouring material like cobaltic oxide, is further to the point. In how far increased compressibility may be expected in a liquid undergoing colloidal solution I cannot say, even when such solution is accompanied by decreasing volume; but as the phenomenon of solution terminates with a datum very near

* Observing that saturation also occurs in colloids below their melting-point in excess of solvent.

to the normal compressibility of water at 200° (so far as known), I am led on the whole to favour a colloidal hypothesis. In an extensive study of the solution of vulcanized indiarubber* in a variety of solvents, the fusion temperature of the saturated coagulated colloid under pressure to a clear solution seemed to be nearly independent of the solvent used. Below this temperature there is saturation and swelling, but no solution. One may therefore regard the opaque stage of the reaction of water on glass as the swelling of a coagulated colloid in presence of its solvent, while the melting-point of the coagulated colloidal glass (as evidenced by the second stage of reaction) would lie below 210° , and probably above 150° C. Another question thus thrusts itself forward: whether the property of swelling is retained by colloids at relatively very low temperatures, seeing that glass at ordinary temperatures does not swell in the presence of water. Finally, the viscosity or stiffness of the fused colloid, and its readiness to coagulate, increases as the amount of solvent per unit of volume decreases.

13. Summarizing the above results, it is best to avoid direct reference to the character of solution, whether colloidal or chemical. An explanation may then be given in terms of the compressibility observed along successive isotherms for the different concentrations of glass solutions at 210° . This at first shows a relatively small value, implying a steep isotherm in a Clapeyron (pv) diagram. Thereafter compressibility passes through a relatively enormous value (over five times the initial result), implying a nearly horizontal isotherm. The reaction ends with even smaller isothermal compressibility than the first observed, implying steeper isotherms than the initial curves. Now, although these isotherms are all at the same absolute temperature, the water-glass is becoming continually more concentrated. Hence the *corresponding temperatures* of the isotherms in van der Waals' sense are continually decreasing. It follows that the reaction considered as a thermodynamic process is a march through the *critical region* of certain phases of the water-glass examined.

In the light given by J. W. Gibbs's investigations, one may arrive at clear notions by adopting but two phases of the water-glass for comparison. Many phases may coexist: two are selected in the interest of brevity, and called phase 1 and 2 respectively. During the earlier stages of the reaction (dilute water-glass) phase 1 is stable. At the end of

* Am. Journal, (3) xlii. p. 359 (1891).

the reaction (concentrated water-glass, subsidence of volume-contraction) phase 2 is stable. Both cases correspond to steep isotherms. Toward the middle region of the reaction (maxima of compressibility) phases 1 and 2 are mutually stable in presence of each other. Hence the horizontal isotherms corresponding to the critical region are cut through in a march from greater to smaller corresponding temperatures.

That phase 2 is really unstable during the first stage of reaction is shown by the approximate constancy of the values of compressibility throughout intervals of pressure as high as could be applied. For instance at 185° :

Pressure interval...	20 to 100,	100 to 200,	200 to 300,	300 to 400 atm.
$10^6 \times \beta$ =	146	144	142	146,

and fifteen minutes later,

$10^6 \times \beta$ =	188	176	201	189.
-----------------------------	-----	-----	-----	------

Again, during the intermediate stage water-glass is without volume elasticity; yielding remarkably to increase of pressure, it refuses to expand when pressure is removed. The last stage is again elastic, but relatively incompressible.

The extreme compressibility, β , of water-glass during the intermediate stage stated deserves special comment. Beginning with igneous glass and water with compressibilities of (say) $\beta = 3 \times 10^{-6}$ and 100×10^{-6} respectively at 210°, values of β are reached which exceed 500×10^{-6} . One may even compare this result with so volatile a body as ethylic ether* at different temperatures between 100 and 200 atm., as follows :—

Temp. of ether.....	29°	65°	100°	185°
$\beta \times 10^6$	156	207	305	741.

Yet the water-glass solidifies in the cold to a hard incompressible colourless body, quite resembling igneous glass.

Brown University,
Providence, R.I., U.S.A.

* Am. Journal, (3) xxxix. p. 488 (1890).

XLIII. *On the Application of Force within a Limited Space, required to produce Spherical Solitary Waves, or Trains of Periodic Waves, of both Species, Equivoluminal* and Irrotational, in an Elastic Solid.* By Lord KELVIN, G. C. V. O., P. R. S. E. †

§ 1. **T**HE complete mathematical theory of the propagation of motion through an infinite elastic solid, including the analysis of the motion into two species, equivoluminal and irrotational, was first given by Stokes in his splendid paper "On the Dynamical Theory of Diffraction" §. The object of the present communication is to investigate fully the force which must be applied to the boundary, S, of a hollow of any shape in the solid, in order to originate and to maintain any known motion of the surrounding solid; and to solve the inverse problem of finding the motion when the force on, or the motion of, S is given, for the particular case in which S is a spherical surface kept rigid.

§ 2. Let ξ, η, ζ denote the infinitesimal displacement at any point of the solid, of which (x, y, z) is the equilibrium position. The well-known equations of motion || are

$$\left. \begin{aligned} \rho \frac{d^2 \xi}{dt^2} &= (k + \frac{1}{3}n) \frac{d\delta}{dx} + n \nabla^2 \xi, \\ \rho \frac{d^2 \eta}{dt^2} &= (k + \frac{1}{3}n) \frac{d\delta}{dy} + n \nabla^2 \eta, \\ \rho \frac{d^2 \zeta}{dt^2} &= (k + \frac{1}{3}n) \frac{d\delta}{dz} + n \nabla^2 \zeta, \end{aligned} \right\} \dots \dots (1)$$

where δ denotes $\frac{d\xi}{dx} + \frac{d\eta}{dy} + \frac{d\zeta}{dz}$. Using the notation of Thomson and Tait ¶ for strain-components (elongations; and distortions), $e, f, g; a, b, c$; we have

$$\left. \begin{aligned} e &= \frac{d\xi}{dx}; & f &= \frac{d\eta}{dy}; & g &= \frac{d\zeta}{dz} \\ a &= \frac{d\eta}{dz} + \frac{d\zeta}{dy}; & b &= \frac{d\zeta}{dx} + \frac{d\xi}{dz}; & c &= \frac{d\xi}{dy} + \frac{d\eta}{dx} \end{aligned} \right\} \dots \dots (2);$$

* By "equivoluminal" I mean every part of the solid keeping its volume unchanged during the motion.

† Communicated by the Author: read before the Royal Society of Edinburgh, May 1, 1899.

§ Stokes, 'Mathematical Papers,' vol. ii. p. 243.

|| See my paper "On the Reflexion and Refraction of Solitary Plane Waves, &c.," Proc. R. S. E. Dec. 1898, and Phil. Mag. Feb. 1899.

¶ Thomson and Tait's 'Natural Philosophy,' § 669, or 'Elements,' § 640.

and with the corresponding notation P, Q, R; S, T, U; for stress-components (normal and tangential forces on the six sides of an infinitely small rectangular parallelepiped), we have

$$\left. \begin{aligned} P &= (k + \frac{1}{3}n)e + (k - \frac{2}{3}n)(f + g); & Q &= (k + \frac{1}{3}n)f + (k - \frac{2}{3}n)(g + e); \\ R &= (k + \frac{1}{3}n)g + (k - \frac{2}{3}n)(e + f) \\ S &= na; & T &= nb; & U &= nc \end{aligned} \right\} (3).$$

Let now σ be an infinitesimal area at any point of the surface S; λ, μ, ν the direction-cosines of the normal; and $X\sigma, Y\sigma, Z\sigma$ the components of the force which must be applied from within to produce or maintain the specified motion of the matter outside. We have

$$\left. \begin{aligned} -X &= P\lambda + U\mu + T\nu \\ -Y &= Q\mu + S\nu + U\lambda \\ -Z &= R\nu + T\lambda + S\mu \end{aligned} \right\} \dots \dots (4);$$

whence by (3)

$$\left. \begin{aligned} -X &= (k - \frac{2}{3}n)\lambda\delta + n(2\lambda e + \mu c + \nu b) \\ -Y &= (k - \frac{2}{3}n)\mu\delta + n(2\mu f + \nu a + \lambda c) \\ -Z &= (k - \frac{2}{3}n)\nu\delta + n(2\nu g + \lambda b + \mu a) \end{aligned} \right\} \dots \dots (5).$$

These equations give an explicit answer to the question, What is the force? when the strain of the matter in contact with S is given. We shall consider in detail their application to the case in which S is spherical, and the motions and forces are in meridional planes through OX and symmetrical round this line. Without loss of generality we may take

$$z = 0; \text{ giving } \nu = 0, a = 0, b = 0, Z = 0 \dots \dots (6)$$

Equations (5) therefore become

$$\left. \begin{aligned} -X &= (k - \frac{2}{3}n)\lambda\delta + n(2\lambda e + \mu c) \\ -Y &= (k - \frac{2}{3}n)\mu\delta + n(2\mu f + \lambda c) \end{aligned} \right\} \dots \dots (7).$$

§ 3. In §§ 5-26 of his paper already referred to, Stokes gives a complete solution of the problem of finding the displacement and velocity at any point of an infinite solid, which must follow from any arbitrarily given displacement and velocity at any previous time, if after that, the solid is left to itself with no force applied to any part of it. In a future communication I hope to apply this solution to the diffraction of solitary waves, plane or spherical. Meantime I confine myself to the subject stated in the title of the

present communication, regarding which Stokes gives some important indications in §§ 27–29 of his paper.

§ 4. Poisson in 1819 gave a complete solution of the equation

$$\frac{d^2w}{dt^2} = v^2 \nabla^2 w \quad (8)$$

in terms of arbitrary functions of x, y, z representing the initial values of w and $\frac{dw}{dt}$; and showed that for every case in which w depends only on distance (r) from a fixed point, it takes the form

$$w = \frac{1}{r} \left\{ F\left(t - \frac{r}{v}\right) + f\left(t + \frac{r}{v}\right) \right\} \quad . . . (9),$$

where F and f denote arbitrary functions. In my Baltimore Lectures of 1884 I pointed out that solutions expressing spherical waves, whether equivoluminal (in which there is essentially different range of displacement in different parts of the spherical surface) or irrotational (for which the displacement may or may not be different in different parts of the spherical surface), can be very conveniently derived from (9) by differentiations with respect to x, y, z . It may indeed be proved, although I do not know that a formal proof has been anywhere published, that an absolutely general solution of (8) is expressed by the formula

$$\Sigma \left(\frac{d}{dx} \right)^h \left(\frac{d}{dy} \right)^i \left(\frac{d}{dz} \right)^j \left\{ \frac{1}{r} \left[F\left(t - \frac{r}{v}\right) + f\left(t + \frac{r}{v}\right) \right] \right\};$$

$$r = \sqrt{[(x-x')^2 + (y-y')^2 + (z-z')^2]} \quad . (10),$$

where Σ denotes sums for different integral values of h, i, j , and for any different values of x', y', z' .

§ 5. I propose at present to consider only the simplest of all the cases in which motion at every point $(x, 0, 0)$ and $(0, y, z)$ is parallel to $X'X$; and for all values of y and z , ξ is the same for equal positive and negative values of x . For this purpose we of course take $x' = y' = z' = 0$; and we shall find that no values of h, i, j greater than 2 can appear in our expressions for ξ, η, ζ , because we confine ourselves to the simplest case fulfilling the specified conditions. Our special subject, under the title of this paper, excludes waves travelling inwards from distant sources, and therefore annuls $f(t + r/v)$.

§ 6. In §§ 5–8 of his paper, Stokes showed that any motion whatever of a homogeneous elastic solid may, throughout every part of it experiencing no applied force, be analysed

into two constituents, each capable of existing without the other, in one of which the displacement is equivoluminal, and in the other it is irrotational. Hence if we denote by (ξ_1, η_1, ζ_1) the equivoluminal constituent, and by (ξ_2, η_2, ζ_2) the irrotational constituent, the complete solution of (1) may be written as follows:—

$$\xi = \xi_1 + \xi_2; \quad \eta = \eta_1 + \eta_2; \quad \zeta = \zeta_1 + \zeta_2 \quad . \quad . \quad . \quad (11),$$

where ξ_1, η_1, ζ_1 and ξ_2, η_2, ζ_2 fulfil the following conditions, (12) and (13), respectively:—

$$\left. \begin{aligned} \frac{d\xi_1}{dx} + \frac{d\eta_1}{dy} + \frac{d\zeta_1}{dz} &= 0 \\ u^2 \nabla^2 \xi_1 &= \frac{d^2 \xi_1}{dt^2}; \quad u^2 \nabla^2 \eta_1 = \frac{d^2 \eta_1}{dt^2}; \quad u^2 \nabla^2 \zeta_1 = \frac{d^2 \zeta_1}{dt^2}; \quad u^2 = \frac{n}{\rho} \end{aligned} \right\} (12);$$

$$\left. \begin{aligned} \xi_2 &= \frac{dw}{dx}; \quad \eta_2 = \frac{dw}{dy}; \quad \zeta_2 = \frac{dw}{dz} \\ w \text{ being any solution of} \\ v^2 \nabla^2 w &= \frac{d^2 w}{dt^2}; \quad v^2 = \frac{k + \frac{4}{3}n}{\rho} \end{aligned} \right\} . \quad . \quad (13).$$

The first equation of (12) shows that in the (ξ_1, η_1, ζ_1) constituent of the solution there is essentially no dilatation or condensation in any part of the solid; that is to say, the displacement is equivoluminal. The first three equations of (13) prove that in the (ξ_2, η_2, ζ_2) constituent the displacement is essentially irrotational.

§ 7. We can now see that the most general irrotational solution fulfilling the conditions of § 5 is

$$\xi_2 = \frac{d^2 F_2}{dx^2} \frac{F_2}{r}; \quad \eta_2 = \frac{d^2 F_2}{dx dy} \frac{F_2}{r}; \quad \zeta_2 = \frac{d^2 F_2}{dx dz} \frac{F_2}{r} \quad . \quad (14),$$

giving

$$\frac{d\xi_2}{dx} + \frac{d\eta_2}{dy} + \frac{d\zeta_2}{dz} = \frac{1}{v^2} \frac{d \ddot{F}_2}{dx r} \quad . \quad . \quad (14');$$

and the most general equivoluminal solution fulfilling the same conditions is

$$\xi_1 = \frac{d^2 F_1}{dx^2} \frac{F_1}{r} - \frac{\ddot{F}_1}{u^2 r}; \quad \eta_1 = \frac{d^2 F_1}{dx dy} \frac{F_1}{r}; \quad \zeta_1 = \frac{d^2 F_1}{dx dz} \frac{F_1}{r} \quad . \quad (15),$$

giving

$$\frac{d\xi_1}{dx} + \frac{d\eta_1}{dy} + \frac{d\zeta_1}{dz} = 0 \quad . \quad . \quad . \quad (15'),$$

where F_1 and F_2 are put for brevity to denote arbitrary functions of $\left(t - \frac{r}{u}\right)$ and $\left(t - \frac{r}{v}\right)$ respectively. Hence the most general solution fulfilling the conditions of § 5 is

$$\xi = \frac{d^2 \phi}{dx^2 r} - \frac{\ddot{F}_1}{u^2 r}; \quad \eta = \frac{d^2 \phi}{dx dy r}; \quad \zeta = \frac{d^2 \phi}{dx dz r} \quad (16),$$

where for brevity ϕ denotes a function of r and t , specified as follows:—

$$\phi(r, t) = F_1\left(t - \frac{r}{u}\right) + F_2\left(t - \frac{r}{v}\right) . . . \quad (17).$$

Denoting now by accents differential coefficients with respect to r , and retaining the Newtonian notation of dots to signify differential coefficients with reference to t , we have

$$\phi' = -\left(\frac{\dot{F}_1}{u} + \frac{\dot{F}_2}{v}\right); \quad \phi'' = \frac{\ddot{F}_1}{u^2} + \frac{\ddot{F}_2}{v^2}; \quad \phi''' = -\left(\frac{\dddot{F}_1}{u^3} + \frac{\dddot{F}_2}{v^3}\right) . \quad (18).$$

Working out now the differentiations in (16), we find

$$\left. \begin{aligned} \xi &= x^2 \left(\frac{\phi''}{r^3} - \frac{3\phi'}{r^4} + \frac{3\phi}{r^5} \right) + \frac{\phi'}{r^2} - \frac{\phi}{r^3} - \frac{\ddot{F}_1}{u^2 r} \\ \eta &= xy \left(\frac{\phi''}{r^3} - \frac{3\phi'}{r^4} + \frac{3\phi}{r^5} \right) \\ \zeta &= xz \left(\frac{\phi''}{r^3} - \frac{3\phi'}{r^4} + \frac{3\phi}{r^5} \right) \end{aligned} \right\} . \quad (19).$$

§ 8. For the determination of the force-components by (7), we shall want values of δ , e , f , and c . Using therefore (2) and going back to (16) we see that

$$c = 2 \frac{d\eta}{dx} - \frac{1}{u^2} \frac{d}{dy} \frac{\dot{F}_1}{r} \quad (20).$$

Hence, and by (19), we find

$$c = y \left\{ 2 \left[x^2 \left(\frac{\phi'''}{r^4} - \frac{6\phi''}{r^5} + \frac{15\phi'}{r^6} - \frac{15\phi}{r^7} \right) + \frac{\phi''}{r^3} - \frac{3\phi'}{r^4} + \frac{3\phi}{r^5} \right] + \frac{1}{r^2} \frac{\ddot{F}_1}{u^3} + \frac{1}{r^3} \frac{\ddot{F}_2}{u^2} \right\} . . . \quad (21).$$

By (16), (14)', and (15)' we find

$$\delta = \frac{1}{v^2} \frac{d}{dx} \frac{\ddot{F}_2}{r} = -x \left(\frac{1}{r^2} \frac{\ddot{F}_2}{v^3} + \frac{1}{r^3} \frac{\ddot{F}_2}{v^2} \right) . . \quad (22);$$

and by (19) directly used in (2) we find

$$\left. \begin{aligned} e &= x \left\{ x^2 \left(\frac{\phi'''}{r^4} - \frac{6\phi''}{r^5} + \frac{15\phi'}{r^6} - \frac{15\phi}{r^7} \right) + 3 \left(\frac{\phi}{r^3} - \frac{3\phi'}{r^4} + \frac{3\phi}{r^5} \right) + \frac{1}{r^2} \ddot{F}_1 + \frac{1}{r^3} \ddot{F}_1 \right\} \\ f &= x \left\{ y^2 \left(\frac{\phi'''}{r^4} - \frac{6\phi''}{r^5} + \frac{15\phi'}{r^6} - \frac{15\phi}{r^7} \right) + \frac{\phi''}{r^3} - \frac{3\phi'}{r^4} + \frac{3\phi}{r^5} \right\} \\ g &= x \left\{ z^2 \left(\frac{\phi'''}{r^4} - \frac{6\phi''}{r^5} + \frac{15\phi'}{r^6} - \frac{15\phi}{r^7} \right) + \frac{\phi''}{r^3} - \frac{3\phi'}{r^4} + \frac{3\phi}{r^5} \right\} \end{aligned} \right\} \quad (23)$$

Remark here how by the summation of these three formulas we find for $e+f+g$ the value given for δ in (22).

§ 9. These formulas (22) and (23), used in (5), give the force-components per unit area at any point of the boundary (S of § 1) of a hollow of any shape in the solid, in order that the motion throughout the solid around it may be that expressed by (19). Supposing the hollow to be spherical, as proposed in § 2, let its radius be q . We must in (23) and (5) put

$$x = q\lambda; \quad y = q\mu; \quad z = q\nu \quad \dots \quad (24);$$

and putting $\nu = 0$, we have, as in (7), the two force-components for any point of the surface in the meridian $z = 0$, expressed as follows:—

$$\left. \begin{aligned} X &= (k - \frac{2}{3}n)C_2\lambda^2 - n\{2\lambda^2A + 2(2\lambda^2 + 1)B + (\lambda^2 + 1)C_1\} \\ Y &= (k - \frac{2}{3}n)C_2\lambda\mu - n\lambda\mu(2A + 4B + C_1) \end{aligned} \right\} \quad (25),$$

where

$$\left. \begin{aligned} A &= \frac{\Phi'''}{q} - \frac{6\Phi''}{q^2} + \frac{15\Phi'}{q^3} - \frac{15\Phi}{q^4} \\ B &= \frac{\Phi''}{q^2} - \frac{3\Phi'}{q^3} + \frac{3\Phi}{q^4} \\ C_1 &= \frac{\ddot{\mathcal{F}}_1}{qu^3} + \frac{\ddot{\mathcal{F}}_1}{q^2u^2} \\ C_2 &= \frac{\ddot{\mathcal{F}}_2}{qv^3} + \frac{\ddot{\mathcal{F}}_2}{q^2v^2} \end{aligned} \right\} \quad \dots \quad (26),$$

Φ and \mathcal{F} denoting ϕ and F with q for r .

§ 10. Returning now to (19), consider the character of the motion represented by the formulas. For brevity we shall call XX' simply the *axis*, and the plane of YY', ZZ' the *equatorial plane*. First take $y=0, z=0$, and therefore $x=r$.

We find by aid of (18)

$$\text{(axial) } \xi = \frac{1}{r} \frac{\ddot{F}_2}{v^2} + \frac{2}{r^2} \left(\frac{\dot{F}_1}{u} + \frac{\dot{F}_2}{v} \right) + \frac{2}{r^3} (F_1 + F_2); \quad \eta=0; \quad \zeta=0 \quad (27).$$

Next take $x=0$ and we find

$$\text{(equatorial) } \xi = -\frac{1}{r} \frac{\ddot{F}_1}{u^2} - \frac{1}{r^2} \left(\frac{\dot{F}_1}{u} + \frac{\dot{F}_2}{v} \right) - \frac{1}{r^3} (F_1 + F_2); \quad \eta=0; \quad \zeta=0 \quad (28)$$

Hence for very small values of r we have

$$\left. \begin{aligned} \text{(axial) } \xi &\doteq \frac{2}{r^3} (F_1 + F_2) \\ \text{(equatorial) } \xi &\doteq -\frac{1}{r^3} (F_1 + F_2) \end{aligned} \right\} \dots \dots \dots (29);$$

and for very large values of r ,

$$\left. \begin{aligned} \text{(axial) } \xi &\doteq \frac{1}{r} \frac{\ddot{F}_2}{v^2} \\ \text{(equatorial) } \xi &\doteq -\frac{1}{r} \frac{\ddot{F}_1}{u^2} \end{aligned} \right\} \dots \dots \dots (30).$$

Thus we see that for very distant places, the motion in the axis is approximately that due to the irrotational wave alone; and the motion at the equatorial plane is that due to the equivoluminal wave alone: also that with equal values of F_1 and F_2 the equivoluminal and the irrotational constituents contribute to these displacements inversely as the squares of the propagational velocities of the two waves. On the other hand, for places very near the centre, (29) shows that both in the axis and in the equatorial plane the irrotational and the equivoluminal constituents contribute equally to the displacements.

§ 11. Equations (25) and (26) give us full specification of the forcive which must be applied to the boundary of our spherical hollow to cause the motion to be precisely through all time that specified by (19), with F_1 and F_2 any arbitrary functions. Thus we may suppose $F_1(t - q/u)$ and $F_2(t - q/v)$ to be each zero for all negative values of t , and to be zero again for all values of t exceeding a certain limit τ . At any distance r from the centre, the disturbance will last during the time

$$\left. \begin{aligned} \text{from} \quad & t = \frac{r-q}{v} \quad \text{to} \quad t = \frac{r-q}{v} + \tau, \\ \text{and from} \quad & t = \frac{r-q}{u} \quad \text{to} \quad t = \frac{r-q}{u} + \tau. \end{aligned} \right\} \dots \dots \dots (31)$$

Supposing $v > u$, we see that these two durations overlap by an interval equal to

$$\left. \begin{aligned} & \frac{r-q}{v} + \tau - \frac{r-q}{u} \\ \text{if } & r-q < \tau / \left(\frac{1}{u} - \frac{1}{v} \right) \end{aligned} \right\} \dots \dots \dots (32).$$

On the other hand, at every point of space outside the radius $q + \tau / (1/u - 1/v)$ the wave of the greater propagational velocity passes away outwards before the wave of the smaller velocity reaches it, and the transit-time of each wave across it is τ . The solid is rigorously undisplaced and at rest throughout all the spaces outside the more rapid wave, between the two waves, and inside the less rapid of the two.

§ 12. The expressions (25) and (26) for the components of the surface-force on the boundary of the hollow required to produce the supposed motion, involve $\ddot{\mathcal{F}}_1$ and $\ddot{\mathcal{F}}_2$. Hence we should have infinite values for $t=0$ or $t=\tau$, unless \dot{F}_1 and \dot{F}_2 vanish for $t=0$ and $t=\tau$, when $r=q$. Subject to this condition the simplest possible expression for each arbitrary function to represent the two solitary waves of § 11, is of the form

$$\mathcal{F} = (1 - \chi^2)^3, \quad \text{where } \chi = \frac{2t}{\tau} - 1 \dots \dots \dots (33).$$

Hence, by successive differentiations, with reference to t ,

$$\left. \begin{aligned} \dot{\mathcal{F}} &= -\frac{12}{\tau} \chi(1 - \chi^2)^2 \\ \ddot{\mathcal{F}} &= \frac{24}{\tau^2} (-1 + 6\chi^2 - 5\chi^4) \\ \ddot{\mathcal{F}} &= \frac{48}{\tau^3} (12\chi - 20\chi^3) \end{aligned} \right\} \dots \dots \dots (34).$$

The annexed diagram of four curves represents these four functions (33) and (34).

§ 13. Take now definitively

$$\left. \begin{aligned} F_1 \left(t - \frac{r}{u} \right) &= c_1 q^3 (1 - \chi_1^2)^3 \\ F_2 \left(t - \frac{r}{v} \right) &= c_2 q^3 (1 - \chi_2^2)^3 \end{aligned} \right\} \dots \dots (35),$$

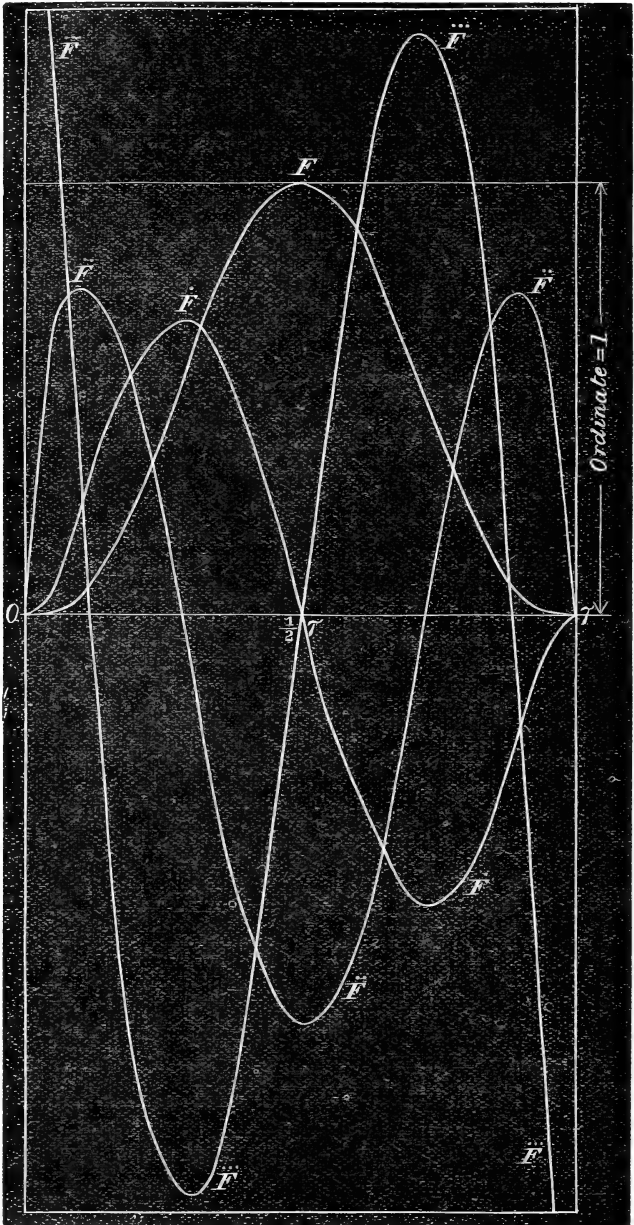

Scale of \ddot{F} = $\frac{1}{5}$ scale of F
 " \dot{F} = $\frac{1}{25}$ " F
 " F = $\frac{1}{125}$ " F

where

$$\left. \begin{aligned} \chi_1 &= \left(t - \frac{r-q}{u} - \frac{1}{2}\tau \right) \div \frac{1}{2}\tau \\ \chi_2 &= \left(t - \frac{r-q}{v} - \frac{1}{2}\tau \right) \div \frac{1}{2}\tau \end{aligned} \right\} \dots (36).$$

Consider now separately the equivoluminal and the irrotational motions. Using (19), (18), (35), (34), and taking the equivoluminal constituents, we have as follows:—

$$\left\{ \begin{array}{l} \text{Equatorial, } x=0; \eta_1=0 \\ \xi_1 = -c_1 \left(\frac{q^3}{r^3} \mathcal{L}_1 + \frac{12q^3}{r^2 u \tau} \mathcal{L}'_1 + \frac{24q^3}{r u^2 \tau^2} \mathcal{L}''_1 \right) \end{array} \right\} \dots (37)$$

$$\left\{ \begin{array}{l} \text{Cone of latitude } 45^\circ, \quad x^2 = xy = \frac{1}{2}r^2 \\ \xi_1 = c_1 \left(\frac{1}{2} \frac{q^3}{r^3} \mathcal{L}_1 + \frac{6q^3}{r^2 u \tau} \mathcal{L}'_1 - \frac{12q^3}{r u^2 \tau^2} \mathcal{L}''_1 \right) \\ \eta_1 = \frac{1}{2}c_1 \left(\frac{3q^3}{r^3} \mathcal{L}_1 + \frac{36q^3}{r^2 u \tau} \mathcal{L}'_1 + \frac{24q^3}{r u^2 \tau^2} \mathcal{L}''_1 \right) \end{array} \right\} \dots (38)$$

$$\left\{ \begin{array}{l} \text{Axial, } x^2=r^2, \quad \eta_1=0 \\ \xi_1 = c_1 \left(\frac{2q^3}{r^3} \mathcal{L}_1 + \frac{24q^3}{r^2 u \tau} \mathcal{L}'_1 \right) \end{array} \right\} \dots (39);$$

where

$$\mathcal{L}_1 = (1 - \chi_1^2)^3; \quad \mathcal{L}'_1 = (1 - \chi_1^2)^2 \chi_1; \quad \mathcal{L}''_1 = -1 + 6\chi_1^2 - 5\chi_1^4. \quad (40).$$

§ 14. Similarly for the irrotational constituents;

$$\left\{ \begin{array}{l} \text{Equatorial, } x=0; \quad \eta_2=0 \\ \xi_2 = -c_2 \left(\frac{q^3}{r^3} \mathcal{L}_2 + \frac{12q^3}{r^2 v \tau} \mathcal{L}'_2 \right) \end{array} \right\} \dots (41);$$

$$\left\{ \begin{array}{l} \text{Cone of latitude } 45^\circ, \quad x^2 = xy = \frac{1}{2}r^2 \\ \xi_2 = c_2 \left(\frac{1}{2} \frac{q^3}{r^3} \mathcal{L}_2 + \frac{6q^3}{r^2 v \tau} \mathcal{L}'_2 + \frac{12q^3}{r v^2 \tau^2} \mathcal{L}''_2 \right) \\ \eta_2 = \frac{1}{2}c_2 \left(\frac{3q^3}{r^3} \mathcal{L}_2 + \frac{36q^3}{r^2 v \tau} \mathcal{L}'_2 + \frac{24q^3}{r v^2 \tau^2} \mathcal{L}''_2 \right) \end{array} \right\} \dots (42);$$

$$\left\{ \begin{array}{l} \text{Axial, } x^2=r^2; \quad \eta_2=0 \\ \xi_2 = c_2 \left(\frac{2q^3}{r^3} \mathcal{L}_2 + \frac{24q^3}{r^2 v \tau} \mathcal{L}'_2 + \frac{24q^3}{r v^2 \tau^2} \mathcal{L}''_2 \right) \end{array} \right\} \dots (43);$$

where \mathcal{X}_2 &c. are given by (40) with χ_2 for χ_1 ; χ_1 and \mathcal{X}_2 being given by (36).

§ 15. The character of the motion throughout the solid, which is fully specified by (19), will be perfectly understood after a careful study of the details for the equatorial, conal, and axial places, shown clearly by (37) . . . (43) for each constituent, the equivoluminal and the irrotational, separately. The curve \mathcal{F} in the diagram of § 12 shows the history of the motion that must be given to any point of the surface S, for either constituent alone, and therefore for the two together, in any case in which q is exceedingly small in comparison with the smaller of the two quantities $u\tau$, $v\tau$, which for brevity we shall call the wave-lengths. The curve $\ddot{\mathcal{F}}$ shows the history of the motion produced by either wave when it is passing any point at a distance from the centre very great in comparison with its own wave-length. But the three algebraic functions \mathcal{F} , $\dot{\mathcal{F}}$, $\ddot{\mathcal{F}}$ all enter into the expression of the motion due to either wave when the faster has advanced so far that its rear is clear of the front of the slower, but *not* so far as to make its wave-length (which is the constant thickness of the spherical shell containing it) great in comparison with its inner radius. Look at the diagram, and notice that in the origin at S, a mere motion of each point in one direction and back, represented by \mathcal{F} , causes in very distant places, a motion ($\dot{\mathcal{F}}$) to a certain displacement d , back through the zero to a displacement $1.36 \times d$ in the opposite direction, thence back through zero to d in the first direction and thence back to rest at zero. Remark that the direction of d is radial in the irrotational wave and perpendicular to the radius in the equivoluminal wave. Remark also that the d for every radial line varies inversely as distance from the centre.

§ 16. Draw any line O P K in any fixed direction through O, the centre of the spherical surface S at which the forcive originating the whole motion is applied. In the particular case of §§ 12 . . . 15, and in any case in which $F_1\left(t - \frac{q}{u}\right)$ and $F_2\left(t - \frac{q}{v}\right)$ are each assumed to be, from $t=0$ to $t=\tau$, of the form $t^3\left(\frac{1}{2}\tau - t\right)^3 A_i t^i$, where i denotes an integer, the time-history of the motion of P is $B_0 + B_1 t + \dots + B_{6+i} t^{6+i}$, and its space-history (t constant and r variable) is $C_{-3} r^{-3} + C_{-2} r^{-2} + \dots + C_{5+i} r^{5+i}$; the complete formula in terms of t and r being given explicitly by (19). The elementary algebraic character of the formula: and the *exact nullity* of the displacement for every point of the solid for which $r > q + vt$; and between

$r=q+v(t-\tau)$ and $r=q+ut$, when $v(t-\tau) > ut$; and between $r=q$ and $r=q+u(t-\tau)$, when $t > \tau$: these interesting characteristics of the solution of a somewhat intricate dynamical problem, are secured by the particular character of the originating force at S, which we find according to §§ 8, 9 to be that which will produce them. But all these characteristics are lost except the first (nullity of motion through all space outside the spherical surface $r=q+vt$), if we apply an arbitrary force to S*, or such a force as to produce any arbitrary deformation or motion of S. Let for example S be an ideal rigid spherical lining of our cavity; and let any infinitesimal arbitrary motion be given to it. We need not at present consider infinitesimal rotation of S: the spherical waves which this would produce, particularly simple in their character, were investigated in my Baltimore Lectures, and described in recent communications to the British Association and Philosophical Magazine †. Neither need we consider curvilinear motion of the centre of S, because, the motion being infinitesimal, independent superposition of x -, y -, z -motions produces any curvilinear motion whatever.

§ 17. Take then definitively $\mathcal{E}(t)$, or simply \mathcal{E} , an arbitrary function of the time, to denote excursion in the direction OX, of the centre of S from its equilibrium-position. Let $\partial^{-1}\mathcal{E}$, $\partial^{-2}\mathcal{E}$ denote $\int_0^t dt \mathcal{E}$ and $\int_0^t dt \int_0^t dt \mathcal{E}$. Our problem is, supposing the solid to be everywhere at rest and unstrained when $t=0$, to find (ξ, η, ζ) for every point of the solid ($r > q$) at all subsequent time (t positive); with

$$\text{at } r=q, \quad \xi = \mathcal{E}(t), \quad \eta = 0, \quad \zeta = 0 \quad . \quad . \quad . \quad (44).$$

These, used in (19), give

$$0 = \frac{\ddot{\mathcal{F}}_1(t)}{u^2} + \frac{\ddot{\mathcal{F}}_2(t)}{v^2} + 3 \left\{ \frac{1}{q} \left[\frac{\dot{\mathcal{F}}_1(t)}{u} + \frac{\dot{\mathcal{F}}_2(t)}{v} \right] + \frac{1}{q^2} [\mathcal{F}_1(t) + \mathcal{F}_2(t)] \right\} \quad (45).$$

and

$$\mathcal{E}(t) = -\frac{1}{q^2} \left[\frac{\dot{\mathcal{F}}_1(t)}{u} + \frac{\dot{\mathcal{F}}_2(t)}{v} \right] - \frac{1}{q^3} [\mathcal{F}_1(t) + \mathcal{F}_2(t)] - \frac{1}{q} \frac{\ddot{\mathcal{F}}_1}{u^2} \quad . \quad . \quad (46),$$

* If the space inside S is filled with solid of the same quality as outside, the solution remains algebraic, if the force formula is algebraic, though discontinuous. The displacement of S ends, not at time $t=\tau$ when the force is stopped, but at time $t=\tau+2q/u$ when the last of the inward travelling wave produced by it has travelled in to the centre, and out again to $r=q$.

† B. A. Report, 1898, p. 783; Phil. Mag. Nov. 1898, p. 494.

Adding $3q \times (46)$ to (45), we find

$$3q\mathcal{E}(t) = -2 \frac{\ddot{\mathcal{F}}_1(t)}{u^2} + \frac{\ddot{\mathcal{F}}_2(t)}{v^2} \dots \dots (47);$$

whence

$$\frac{\mathcal{F}_2(t)}{v^2} = 2 \frac{\mathcal{F}_1(t)}{u^2} + 3q\partial^{-2}\mathcal{E}(t) \dots \dots (48);$$

and by this eliminating \mathcal{F}_2 from (46),

$$\left[\partial^2 + \frac{1}{q}(u+2v)\partial + \frac{1}{q^2}(u^2+2v^2) \right] \mathcal{F}_1(t) = \mathcal{G}(t) \dots (49),$$

where ∂ denotes d/dt , and

$$\mathcal{G}(t) = -qu^2 \left(1 + \frac{3v}{q}\partial^{-1} + \frac{3v^2}{q^2}\partial^{-2} \right) \mathcal{E}(t) \dots (50).$$

§ 18. I hope later to work out this problem for the case of motion commencing from rest at $t=0$, and $\mathcal{E}(t)$ an arbitrary function; but confining ourselves meantime to the case of \mathcal{S} having been, and being, kept perpetually vibrating to and fro in simple harmonic motion, assume

$$\mathcal{E}(t) = h \sin \omega t \dots \dots (51).$$

With this, (50) gives

$$\mathcal{G}(t) = hqu^2 \left[\left(\frac{3v^2}{q^2\omega^2} - 1 \right) \sin \omega t + \frac{3v}{q\omega} \cos \omega t \right] \dots (52).$$

To solve (49) in the manner most convenient for this form of $\mathcal{G}(t)$, we now have

$$\begin{aligned} \mathcal{F}_1(t) &= \frac{1}{\partial^2 + \frac{1}{q}(u+2v)\partial + \frac{1}{q^2}(u^2+2v^2)} \mathcal{G}(t) \\ &= \frac{\partial^2 + \frac{1}{q^2}(u^2+2v^2) - \frac{1}{q}(u+2v)\partial}{\left[\partial^2 + \frac{1}{q^2}(u^2+2v^2) \right]^2 - \left[\frac{1}{q}(u+2v)\partial \right]^2} \mathcal{G}(t) \\ &= hqu^2 \times \\ &\frac{\left\{ \frac{3v^2}{q^4\omega^2}(u^2+2v^2) + \frac{1}{q^2}(v^2+3vu-u^2) + \omega^2 \right\} \sin \omega t + \frac{u-v}{q\omega} \left(\frac{3uv}{q^2} + \omega^2 \right) \cos \omega t}{\left[\frac{1}{q^2}(u^2+2v^2) - \omega^2 \right]^2 + \frac{\omega^2}{q^2}(u+2v)^2} \dots \dots (53). \end{aligned}$$

With \mathcal{F}_1 thus determined, (48) gives \mathcal{F}_2 as follows,

$$\frac{\mathcal{F}_2(t)}{v^2} = \frac{2\mathcal{F}_1(t)}{u^2} - \frac{3hq}{\omega^2} \sin \omega t \quad \dots \quad (54).$$

For ξ, η, ζ by (19) we now have

$$\left. \begin{aligned} \xi &= B(r, t)x^2 - \frac{1}{r^2} \left[\frac{\dot{\mathcal{F}}_1(t_1)}{u} + \frac{\dot{\mathcal{F}}_2(t_2)}{v} \right] - \frac{1}{r^3} [\mathcal{F}_1(t_1) + \mathcal{F}_2(t_2)] - \frac{1}{r} \frac{\ddot{\mathcal{F}}_1(t_1)}{u^2} \\ \eta &= B(r, t)xy \\ \zeta &= B(r, t)xz \end{aligned} \right\} (55),$$

where (compare § 9 above)

$$\left. \begin{aligned} B(r, t) &= \frac{1}{r^3} \left[\frac{\ddot{\mathcal{F}}_1(t_1)}{u^2} + \frac{\ddot{\mathcal{F}}_2(t_2)}{v^2} \right] + \frac{3}{r^4} \left[\frac{\dot{\mathcal{F}}_1(t_1)}{u} + \frac{\dot{\mathcal{F}}_2(t_2)}{v} \right] \\ &\quad + \frac{3}{r^5} [\mathcal{F}_1(t_1) + \mathcal{F}_2(t_2)] \end{aligned} \right\} \dots \quad (56).$$

$$\left. \begin{aligned} t_1 &= t - \frac{r-q}{u}; & t_2 &= t - \frac{r-q}{v} \end{aligned} \right\}$$

§ 19. The wave-lengths of the equivoluminal and rotational waves are respectively $\frac{2\pi u}{\omega}$ and $\frac{2\pi v}{\omega}$. For values of r very great in comparison with the greater of these, the second members of (55) become reduced approximately to the terms involving $\ddot{\mathcal{F}}_1$ and $\ddot{\mathcal{F}}_2$. These terms represent respectively a train of equivoluminal waves, or waves of transverse vibration, and a train of irrotational waves, or waves of longitudinal vibration; and the amplitude of each wave as it travels outwards varies inversely as r .

§ 20. For the case of an incompressible solid we have $v = \infty$, which by (53) gives

$$\frac{\ddot{\mathcal{F}}_1(t)}{u^2} = -\frac{3}{2}hq \sin \omega t \quad \dots \quad (57);$$

and by (55) we have, for r very great,

$$\left. \begin{aligned} \xi &\doteq -\frac{3}{2}hq \sin \omega t \left(\frac{x^2}{r^3} - \frac{1}{r} \right) \\ \eta &\doteq -\frac{3}{2}hq \sin \omega t \frac{xy}{r^3} \\ \zeta &\doteq -\frac{3}{2}hq \sin \omega t \frac{xz}{r^3} \end{aligned} \right\} \dots \quad (58),$$

which fully specify, for great distances from the origin, the wave-motion produced by a rigid globe of radius q , kept moving to and fro according to the formula $h \sin \omega t$.

[To be continued.]

XLIV. *Denudation and Deposition.*

To the Editors of the *Philosophical Magazine.*

GENTLEMEN,

DR. G. JOHNSTONE STONEY'S paper on this subject in your April number will, I think, somewhat startle practical men, whether geologists or engineers. If I rightly understand him, he concludes that to increase the radius of the earth one has only to remove its surface-layers, and conversely. The problem which Dr. Stoney considers on p. 373 is simply that of an elastic solid sphere of uniform bulk-modulus (resistance to compression) acted on by a uniform surface pressure. If p be the pressure, a the radius, and k the bulk-modulus, the surface displacement, as is well-known, is

$$u = -pa/3k ;$$

and if one puts

$$a = 64 \times 10^7 \text{ centim.},$$

$$p = g,$$

$$k = 423 \times 10^6 g,$$

i. e., if one supposes a to be the earth's radius, g 'gravity' at its surface, p the pressure due to a layer 1 centim. deep of water, and k the largest value quoted for the bulk-modulus of glass in Lord Kelvin's *Encyclopædia* article—one gets in agreement with Dr. Stoney

$$u = -0.5 \text{ centim. approx.}$$

If, however, Dr. Stoney treats the earth as perfectly elastic throughout for pressure introduced by the action of its gravitation on fresh surface material, it is difficult to see how he can avoid treating it as also perfectly elastic so far as concerns the gravitational forces between the already existing material. It may be legitimate enough to hold that the deep-seated material has had its elasticity, so to speak, "killed" under the enormous pressure to which it is exposed; but this view does not appear consistent with treating this identical material as responding like glass to a slight increment of exactly the same type of pressure stress. To see the nature of the results to which we are led by the hypothesis that the earth as a whole behaves like glass, let us glance for a moment at the expression for the surface displacement due to the mutual gravitation of a homogeneous elastic sphere, *viz.*,

$$u = -gpa^2/15k,$$

when we ascribe to a and k the values quoted above, and put

$\rho = 5.5$. [The assumption of uniform density is merely for simplicity; one can easily allow for variation in the density with the radial distance, but this does not affect the order of magnitude of u .]

From the above value of u , under the conditions supposed, I find

$$u = -(7/13)a \text{ approx.}$$

In other words the earth would possess an *elastic* displacement of fully 2000 miles at the surface. My own view, advocated some years ago in your pages*, with, I have reason to think, pretty general approval from elasticians†, is that results deduced by treating the earth as an elastic solid of the normal type cannot be taken seriously unless they make the strains small quantities of the order allowed by the ordinary mathematical and physical theories.

The only satisfactory way, so far as I know, of deducing results consistent with perfect elasticity is to treat the earth as incompressible, or very nearly incompressible, throughout all but the surface strata (Dr. Stoney's 'lithosphere'). If we suppose the lithosphere homogeneous and perfectly elastic, its thickness d being small compared to the earth's radius a , and suppose the underlying material incompressible, the displacement u' at the surface, due to uniform surface pressure p , is approximately given by ‡

$$u' = -3pd/(3k + 4n),$$

where k is the bulk-modulus, and n the rigidity, for the lithosphere.

If u represent as before the surface displacement on Dr. Stoney's hypothesis of a uniform value k for the bulk-modulus, we have

$$u'/u = 3 \frac{d}{a} \frac{3k}{3k + 4n}.$$

Supposing $n = 3k/5$, the relation given by uniconstant isotropy, which is at least a fair approximation in ordinary glass, we have

$$u'/u = (5d/3a).$$

This makes u'/u about 1/80 when the lithosphere is 30 miles thick.

I do not attach any importance to the numerical estimate

* Phil. Mag. September 1891, pp. 233-252.

† Cf. Todhunter & Pearson's 'History . . of Elasticity,' vol. ii. part 2, arts. 1721-1723; and Love's 'Treatise on . . Elasticity,' vol. i. arts. 127, 180, &c.

‡ Deducible from results in Phil. Mag. vol. xxxviii. (1894) p. 175.

just made, except as giving some idea of the large reduction it would be advisable to make in Dr. Stoney's figures. The lithosphere of course is not homogeneous, and alteration in the bulk-modulus with the depth must almost certainly be gradual.

I would also point out that, whether one treats the earth as possessed of uniform elasticity or not, data deduced from uniform surface loading are hardly calculated to throw much light on what happens when the loaded area is but a small fraction of the surface. If the loaded area be only a few hundred, or even thousand, square miles, a much better idea of the order of magnitude of the *elastic* effects due to denudation or deposition would probably be obtained by an application of Cerruti and Boussinesq's results* for a locally loaded infinite plane. As to possible gradual—*i. e.* nonelastic and viscous—results, elastic solid theory is but an imperfect guide.

April 6, 1899.

CHARLES CHREE.

XLV. Notices respecting New Books.

Matter, Energy, Force, and Work; A Plain Presentation of Fundamental Physical Concepts and of the Vortex-Atom and other Theories. By SILAS W. HOLMAN, Emeritus Professor of Physics in the Massachusetts Institute of Technology. New York: The Macmillan Company, 1898.

THE aim of the author in writing this volume has been to present the fundamental definitions and concepts of physics in a logical order. Assuming the existence of space, he points out that certain portions of it are possessed of the power to affect our senses and other portions of space; in such portions *substance* exists. Substance is composed of matter, and its power to produce external effects may be attributed to the energy of motion of its matter; matter of itself having no properties except that it occupies space and can possess kinetic energy. The concept of energy is thus made more fundamental than that of force, which is defined as the action of energy in producing a tendency to change of motion of bodies. This treatment leads to the doctrine of the conservation of energy and a discussion concerning the nature of the various forms of energy, and is followed, in the second part of the volume, by an account of the vortex-atom theory of matter.

The author appears to us to have introduced an unnecessary complication into his work by his respect for the term *mass* as ordinarily used to indicate quantity of matter. The term has no meaning until the method of estimating quantities of matter has been agreed upon; ordinarily, mass is measured by its capacity for acquiring momentum under given velocity, because force and momentum are regarded as more fundamental than energy; it is,

* See Todhunter & Pearson's 'History,' vol. ii. part 2, arts. 1489 *et seq.*, or Love's 'Elasticity,' vol. i. chapter 9, also Phil. Mag. March 1897, p. 173.

however, equally legitimate to apply the same term to the capacity of the body for acquiring energy under given velocity. As kinetic energy depends on the square of the velocity there is a troublesome factor $\frac{1}{2}$, which must either be got rid of by an equally vexatious system of units or else it must be left in the equations. The confusion occasioned by it is exhibited on p. 66, where we read that the customary unit of kinetic energy "is *one-half* of that possessed by one gramme when moving with a velocity of one centimetre per second. It is called the erg."

Readers of the book, whether they agree with the views of the author or not, cannot fail to have their attention drawn to the fundamental concepts of mechanics and physics and the evidence on which they are founded; this must necessarily lead to clearer views and a greater appreciation of the modern theories sketched briefly in the second part of this volume. J. L. H.

An Introduction to the Theory of Analytic Functions. By J. HARKNESS, M.A., and F. MORLEY, Sc.D. (London, Macmillan, 1898, pp. xvi + 336.)

THE previous treatise on the Theory of Functions by the same writers was published in 1893. This work, as the authors state and as is obvious on examination, is not an abridged and elementary version of the other, but is almost a totally independent work. Our last remark is due to the fact that there are fewer references on account of a fuller list having been given before. Let the Authors speak for themselves: "It has been composed with different ends in mind, deals in many places with distinct orders of ideas, and presents from an independent point of view such portions of the subject as are common to both volumes.

"Owing to the nonexistence of any English text-book giving a consecutive and elementary account of the fundamental concepts and processes employed in the theory of functions, the authors have sent forth their volume to meet this pressing want." The rest of the preface gives an interesting sketch of what they attempt, and after a perusal of great part of their work, we are convinced that they will meet with the reward they hope for.

There are twenty-two chapters in all, an Index, and Contents. The earlier portion on the Ordinal Number System, Geometric Representation of Complex Numbers, the Bilinear Transformation and the Geometric Theory of the Logarithm and the Exponential, we read with much interest and found them to be very clearly done. Chapters viii.–xii. discuss the different points of difficulty connected with Power Series. Then we have (xiii.) the Analytic Theory of the Exponential and Logarithm. Chapters xv.–xviii. consider Weierstrass's Factor-theorem, Integration, Laurent's Theorem and the Theta-functions, and functions arising from a network. Elliptic and Algebraic functions (on Riemann surfaces) follow, and the book closes with Cauchy's Theory and the Potential. Possessors of the earlier volume will see that some of the headings above are identical with those in that work, but they will find that the treatment is fresh, as stated in the extract from the preface above.

XLVI. *Proceedings of Learned Societies.*

GEOLOGICAL SOCIETY.

[Continued from p. 420.]

January 4th, 1899.—W. Whitaker, B.A., F.R.S., President,
in the Chair.

THE following communications were read:—

1. 'Geology of the Ashbourne and Buxton Branch of the London and North-Western Railway.—Ashbourne to Crake Low.' By H. H. Arnold-Bemrose, Esq., M.A., F.G.S.

The southern part of the new railway from Ashbourne, through Tissington and Crake Low, to Buxton exhibits several sections in Trias, Boulder Clay, Mountain Limestone, and Yoredale Beds. Interstratified with the latter is a thick bed of volcanic ash, with thinner intercalations of tuff. Within a mile of Tissington ash is exhibited four times in the cuttings, and according to the view of the author it is the same bed repeated by basins and domes, one of the latter of which is faulted. While the rocks succeeding the ash in some places are limestones, cherts, and shales of Yoredale type, in one section they resemble more closely the upper beds of the Mountain Limestone. The limestones are often dolomitized. The ash-bed is 144 feet thick where fully exposed: it is stratified, the beds varying in texture, and the lapilli in them range from microscopic dimensions to 1 inch in diameter. The lapilli are glassy or palagonitic; but felspar-microlites are rare, and the rock of which they are made has no counterpart among the lavas of the county. The ejected blocks in the ash vary from several inches up to 1 foot in diameter, and are similar to the blocks in the vent at Kniveton. The small lapilli scattered through the limestones are generally converted into calcite or dolomite with oxide of iron. The paper is illustrated by microscopic slides, and horizontal and vertical sections of the cuttings and quarries described; also by hand-specimens, photographs, and lantern-slides.

2. 'The Oceanic Deposits of Trinidad.' By Prof. J. B. Harrison, M.A., F.G.S., and A. J. Jukes-Browne, Esq., B.A., F.G.S.

'The object of this communication is to present some observations on the succession and geological relations of the beds which have long been known in Trinidad as the Naparima Marls. This name was given by Messrs. Wall & Sawkins in 1860, on account of their occupying a large part of the Naparima district east and south-east of San Fernando. The beds so named formed one of the five series which were described by these authors under the head of the Newer Parian Group.' In his historical introduction Mr. Jukes-Browne deals with the writings of Mr. Guppy and Prof. Harrison, and shows that three definite issues are thus raised:—(1) Are the Nariva Beds above or below the Naparima Marls? (2) Do the *Globigerina*-marls

occur in the Naparima district, and, if so, are they connected with the Radiolarian marls or are they part of a separate formation? (3) What is the relation between the San Fernando Beds and the other groups? Mr. Guppy and Prof. Harrison agree in answering the first part of the second question in the affirmative, and in stating that the two marls are closely connected together.

In the second part of the paper, Prof. Harrison tabulates the following succession in the Naparima district:—

- | | | |
|--|---|-----------------|
| 3. Radiolarian beds resembling those of Barbados. | } | Oceanic Series. |
| 2. Grey <i>Globigerina</i> -marls, the same as those of the coast-section. | | |
| 1. Red and blue clays. | | Nariva Beds. |

Although junctions of the Nariva Beds and the Oceanic Series are not seen, at Ste. Madeleine Usine the clays of the former series occur 30 feet lower than the *Globigerina*-marls, and there appears to be no transition between the two series. On the other hand, the transition between (2) and (3) appears to be complete. A comparison with the corresponding beds at Barbados now becomes possible, and this shows that the *Globigerina*-marls occupy the place of the basal chalks of Barbados, but are much thicker, while the radiolarian rocks are thinner, and the interbedded volcanic ashes so frequent in Barbados are wanting in Trinidad. Chemical and microscopic analyses of the *Globigerina* and radiolarian beds are given, and, compared with similar analyses of the Barbadian deposits, they show that more quartz and argillaceous matter occur in Trinidad. The radiolarian marls contain iridescent scales due to fragments of the frustules of the diatom *Ethmodiscus*, which is 'quite characteristic of some of the deepest tropical red clays and radiolarian oozes far from land.' The 'argiline' beds appear to be formed from the alteration of the lower *Globigerina*-marls. The following correlation is proposed:—

BARBADOS.	TRINIDAD.	
Coral Rocks. } Bissex Beds. } Oceanic Beds.	Moruga Series. Naparima Marls.	{ Pleistocene & { Pliocene. Miocene.
Scotland Beds. { Upper. Lower. }	San Fernando Beds. Nariva Series.	{ Oligocene & { Eocene.

The Oligocene and Eocene Beds are of shallow-water origin, and seem to be unconformably covered by the Naparima Marls.

XLVII. Intelligence and Miscellaneous Articles.

A FIVE-CELL QUADRANT ELECTROMETER. BY PROF. H. HAGA.

PROF. H. HAGA describes a five-cell quadrant electrometer which has been constructed according to his design in the Physical Laboratory of the University of Groningen. A special feature

is the means applied for damping the oscillations of the combined system of five needles. This consists of a thin copper cylinder, movable in a strong magnetic field, and attached coaxially to the aluminium stem carrying the needles, which is continued downwards below the quadrants for this purpose. The magnetic field in which the cylinder moves is formed as follows:—a permanent magnet, whose axis forms a nearly complete horizontal circle, is fastened close below the sole-plate of the instrument, so that the axis of suspension of the needles and copper cylinder passes through the centre of the space between the poles, which are furnished with soft iron pole-pieces in the opposing faces of which grooves of semicircular section are cut. A cylindrical space is thus formed, which is closed on all sides; above, by the sole-plate of the electrometer (except for a hole large enough to let the aluminium stem carrying the copper cylinder pass freely); below, by a brass plate carrying a short copper tube in which an iron core of rather smaller radius than the copper damping cylinder fits closely and can be slid up or down with slight friction; at the sides by brass plates closing the air-gaps between the pole-pieces. The damping cylinder is thus thoroughly protected from air-currents and moves in the annular space between the hollowed out surfaces of the pole-pieces and the iron core just mentioned.

In order to be able to regulate the damping, the copper cylinder is adjusted, by thinning and shortening, until the movement is just aperiodic when the iron core is pushed right up. Then by moving the core downward, any required degree of damping can be obtained. The total suspended system weighs 20 grammes. The suspending fibre is 17 cm. long and is attached at the top to a torsion head. The author has tried a silvered quartz fibre of 55μ diameter, but finds an annealed platinum wire of 50μ on the whole the most convenient. With this suspension the half-period was about 12 seconds, and, as the damping was so regulated that the needles came to rest after three swings, readings could be taken at intervals of about 36 seconds. The needles were charged by being connected with the positive terminal of a set of 300 Leclanché cells, the negative of which was to earth. With a scale-distance of 2 metres, a Clark cell gave, by reversal, a deviation of about 600 mm., and the same values could be obtained repeatedly within 2 or 3 tenths of a millimetre; in other words, measurements can be made with the electrometer with an accuracy of fully one part in 1000.

The author gives a series of readings illustrating the proportionality between potential-difference and deflection, and also examples of the use of the instrument for the comparison of electromotive forces, of current-strengths by the potentiometer method, and of the constant of a galvanometer.—(Abstract of paper communicated by the Author from the *Proceedings of the Royal Academy of Sciences, Amsterdam*, for June 25th, 1898.)

THE
LONDON, EDINBURGH, AND DUBLIN
PHILOSOPHICAL MAGAZINE
AND
JOURNAL OF SCIENCE.

[FIFTH SERIES.]

JUNE 1899.

XLVIII. *Thickness of the Black Spot in Liquid Films.*
By EDWIN S. JOHONNOTT, Jun.*

INTRODUCTION.

THE principal object of the measurement of the thickness of the black spot on certain liquid films is to determine the radius of molecular attraction, which is supposed to be equal to half the thickness of the film. The first determination of the thickness of the film was made by Plateau †, who gives it as 120×10^{-6} millim. or $120 \mu\mu$. The present generally accepted value is that given by the experiments of Professors Reinold and Rücker ‡, viz., $12 \mu\mu$ for the thickness.

They employed two methods, the first consisting in measuring the electrical resistance of cylindrical films, and the second in determining the relative retardation of two beams of light, one of which had been transmitted through a larger number of films than the other.

P. Drude §, by considering the effect of capillarity on the reflexion and refraction of light, obtained a value of $17 \mu\mu$ for the thickness. He also gives a good historical summary of the work that has been done on the determination of the radius of molecular attraction. Lord Rayleigh || has also shown that an olive-oil film $2 \mu\mu$ thick will just quiet the movements of camphor particles on a water surface.

* Communicated by the Author.

† *Statique des Liquides*, vol. i. p. 210.

‡ Phil. Trans. 1881, p. 447; 1883, p. 645; and 1893 (A), p. 505.

§ Wied. Ann. vol. xliii. (1891), pp. 126-157 and 158-176.

|| Proc. Roy. Soc. vol. xlvii. (1889-90), p. 364.

Two methods, both suggested by Prof. Michelson, were used in making the measurements here given, the first, an interferometer method, the second, a photometric method.

In the first method continuous readings, for the mean thickness of a number of films, were made over a period of several hours. In the second method the thickness of a single film was determined from the intensity of the light reflected at a series of different angles of incidence. Since it was impossible to obtain monochromatic lights sufficiently intense, this method does not furnish accurate results.

The liquid used was a solution of either oleate of soda or oleate of potash in distilled water, the proportions ranging from 1 part of oleate to 100 of water (1 : 100), to 1 part of oleate to 40 of water (1 : 40). Tests were made with potassium nitrate and also glycerine added to the above solutions.

The index of refraction of all the solutions was assumed to be that of pure water, viz., 1.333. All the measurements were made on vertical films, formed on rectangular frames made of glass fibre. The lower edge of the films was on the surface of the solution in all cases.

METHOD I.

Prof. Michelson's interferometer was used in making the measurements by this method.

Description of Apparatus.—The two reflectors were placed at A and B, on a stone slab 2 feet by 2 feet (fig. 1), and the separating surface and compensator at C. The films were brought into the path, BC, of the interferometer, at F, on frames made of glass fibre 0.5 millim. in diameter. In mounting the frames, a $\frac{3}{8}$ -inch round brass rod 35 centim. long was slit lengthwise into halves. 60 grooves, at intervals of 5 millim. were ruled on the flat surface of one of the halves. A glass fibre 7 centim. long was clamped centrally in each groove by means of a long square rod faced with chamois skin. Upon levelling the plane of the fibres and carrying a fine flame along the edges of the grooved surface, all of the frames were formed in vertical planes. The frames were then all brought to a common length by forming beads on the lower ends with the flame. These ends were then lowered into molten solder in a trough made from a piece of $\frac{1}{2}$ -inch brass tubing, slitted longitudinally. After cooling, the clamp was removed, leaving 54 frames rigidly mounted and perfectly in line at the tops and sides. Each end of the supports of the frames was then attached, by means of small wind-

lasses, to the ends of a zinc trough holding 500 cub. centim. of the solution. This was covered with a glass casing, C (fig. 2), made from a tube by removing a longitudinal section. Two optically plane parallel pieces of glass covered the ends of the case ; while two plane parallels of the same thickness

Fig. 1.

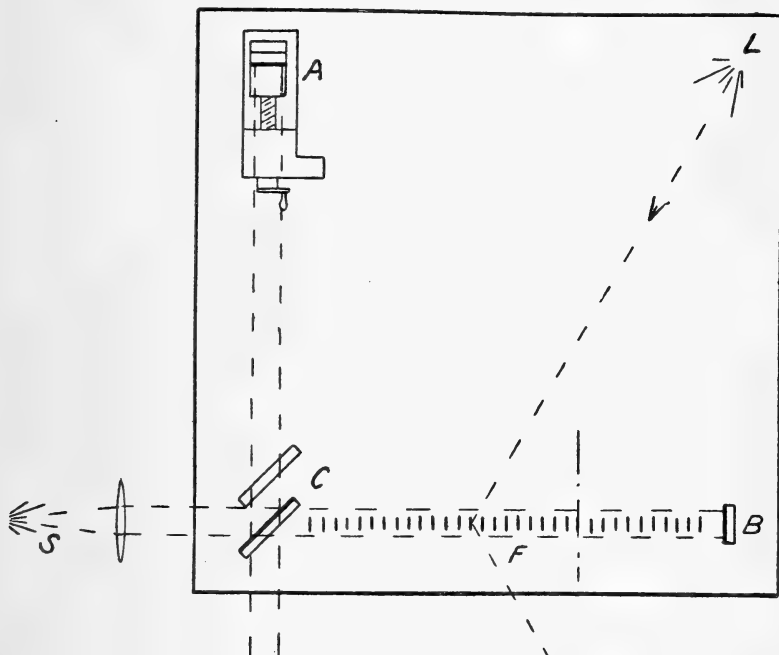

were placed at the ends of a similar piece of tubing in the other path of the interferometer. Cementing with beeswax or paraffin prevented any unsteadiness of the fringes, and also provided a practically air-tight chamber for the films.

Fig. 2 shows a full-sized cross-sectional view of the film box. The frames are shown anchored in the solder at D, while the film is shown formed at H. The temperature readings were taken with a thermometer, T, inside of the case, and held away from the walls by rubber rings.

Methods of Observation.—By turning the windlasses, the films could be brought into the path of the interferometer and so adjusted that the displaced fringes appeared contiguous with those from the light not going through the films. Using

Fig. 2.

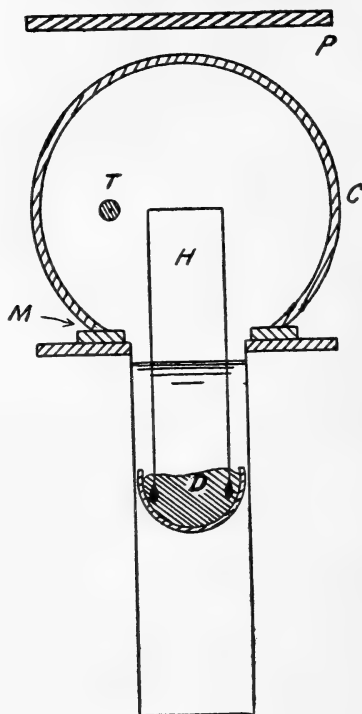
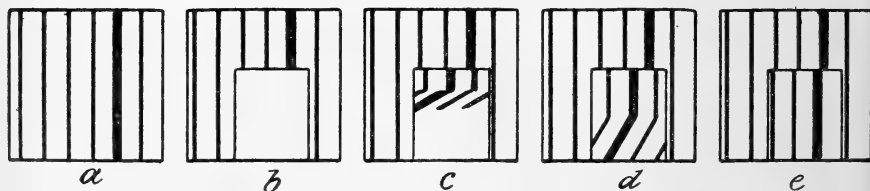

Fig. 3.



vertical fringes of white light, the appearance is as shown in fig. 3. (a) represents the appearance when the frames are below the surface of the solution ; (b) when the films are first formed. The fringes, of course, do not show within the image of the frames, and only the broad horizontal bands of the coloured films are seen. As soon as the black film forms at the tops of all the frames the vertical fringes are seen displaced within the frames, and take successively the appearances shown in (c), (d), and (e).

The number of fringes displacement is determined by that of the central black fringe in the white-light fringes, which is shown in the figures broader than the adjacent coloured fringes. The fringes continue vertical within the image of the frames until they reach the boundary between the black and coloured films, and then slant off at a continuously increasing slope as the black films extend lower. When the black films cover the field, which usually occurs within five minutes after the frames are raised, the appearance is shown in (e).

When the atmosphere about the films has been enclosed a day or more, the tops of the coloured films may occur on the same level, preventing at first the appearance of the sloping portion of the fringes. This would indicate a considerable discontinuity in the thickness at the junction of the black and coloured films. A bodily shift of the sloping portion (e) was often noticed.

Methods of Measurement.—One of the advantages of this method is that there can be no great difference in the optical path inside and outside of the frames at their tops, except that due to the films; and the fact that the fringes usually continue vertical within the image of the frames indicates that there is practically none. Another advantage is that the deflexion is the same as that which would be due to a single transmission through twice the number of films.

The measurements were all taken at the tops of the frames when the fringes were vertical. The calculations were made by using the wave-length of sodium light in the formula, although the white-light fringes were as often used in taking the readings, which were always eye-estimates of the displacement of the fringes.

The equation

$$D = \frac{\delta\lambda}{2N(\mu - 1)}$$

gives the relation for finding the mean thickness of the films where

δ is the observed displacement of the fringes,

N the number of films,

$\lambda = 589\mu\mu$, the wave-length of sodium light,

$\mu = 1.333$, the index of refraction of pure water, and

D the mean thickness of the films.

The Two Black Films.—With all solutions a very rapid fall in the thickness occurs when the black films have just been formed, and continues with greater or less rapidity according as the atmosphere about the films is more or less

exposed to heat or to the atmosphere of the room. (The films will be said to be "exposed" when the casing is unsealed and the atmosphere about the films is exposed to that of the room at crevices along the casing M (fig. 2).) Solutions of oleate of soda or potash, without any salt or glycerine added, show the greatest and most sudden changes in thickness. It was observed that these sudden changes were always accompanied by the formation of a second black film within the first. When the case was open or only partially sealed, this second black was seen to form first on the more exposed films in the case, and on the side of the frames toward a distant source of heat. A group of round spots would appear, at least two millimetres from the frames, and would expand and multiply until the whole upper part of the films was covered with the second black. This was also the case with films tightly sealed if the casing was warmed with a flame. With exposed or heated films the second black would soon appear on all the frames, after it had formed on the most exposed. Many times it would form by the expansion of a single spot, appearing as though the spot were a region of slightly smaller surface-tension in the first black film.

The slightest occurrence of the second black film was distinctly seen by arranging a gas-jet at L (fig. 1), and observing the reflected light. The spots would occur first on the upper corner nearest the light, unless the side of the case opposite the light was unsealed, while that toward it was sealed; then they would form first on the more exposed side. Oftentimes a thick silvery film would form on the frames, as a boundary to the second black film.

This could usually be produced by warming an exposed film.

The second black on a liquid film was first observed by Newton*. Reinold and Rucker† on one occasion succeeded in getting the two black films successively between their needles. The resistance of the two films indicated thicknesses of $200\ \mu\mu$ and $110\ \mu\mu$ respectively. These numbers are evidently much too large, the error being due, as their experiments show, to a difference in the specific resistance of the film and that of the solution.

Again, the second black film will not appear when the films have been sealed in for any length of time, and the first black film may remain at a high thickness, particularly if the temperature is low and not increasing. In all cases, however, the limiting thickness of the first black film, before

* Lord Kelvin, 'Constitution of Matter,' p. 177.

† Phil. Trans. (A) 1893, p. 512.

breaking into the second, is about twice the thickness of the second. From this it might be inferred that the thickness of the second black film is possibly once the radius of molecular attraction, or some multiple, while the limiting thickness of the first is twice as great.

It is generally considered that the film whose thickness is once the radius of molecular attraction has a smaller tension than one twice as thick, and would thus be unstable. Maxwell*, however, has shown, on the assumption that the density is uniform in a region within the distance equal to the radius of molecular attraction from the surface of a liquid, and equal to the density of the liquid in mass, that a film whose thickness is once the radius of molecular attraction would have the same surface-tension as one twice as thick. That is, a film whose thickness is once the radius would be stable.

Statement of Results.—A curve illustrating the effect of temperature changes on the thickness of the sealed black film is first given.

Fig. 4 (p. 508).—This curve was taken May 6th, with a 1 : 70 oleate of soda solution that had been sealed 24 hours. 38 of the original 54 films remained to the end of 40 hours. The abscissæ represent the age of the film in hours, and the ordinates, on the left, the mean thickness in $\mu\mu$; on the right the ordinates represent the temperature in degrees centigrade. No attempt was made to influence changes in the temperature. The whole apparatus was enclosed in a thick wooden box and the room carefully guarded against air-currents. No observation was made for the second black film as this was taken before its existence had been noticed. Apparently the inflexions of the thickness-curve follow, inversely, those of the temperature-curve, indicating an increase in thickness with a fall in temperature. Owing to the small deflexion and fewer films, the readings became more uncertain towards the end; hence, there the thickness-curve is not drawn as indicated by the points. When there are 54 films a deflexion of one fringe corresponds to a mean thickness of $16\ \mu\mu$.

Hygrometric Condition.—This curve, taken with the fact that exposure tends to thin the films, would indicate that the thickness depends on the hygrometric condition of the atmosphere about the films. An unsatisfactory attempt was made to measure the relative humidity with a wet and dry bulb hygrometer. Even with as great an exposure as was used in any observation, the difference in the readings of the thermometers was less than $0^{\circ}\cdot 2$, which at 23°C . would indicate a relative humidity greater than $\cdot 995$.

* "Capillary Action," *Encyc. Brit.*

While the thickness of the first black film always diminishes with a rise in temperature, the thicknesses corresponding to any temperature are widely different for films from different

Fig. 4.

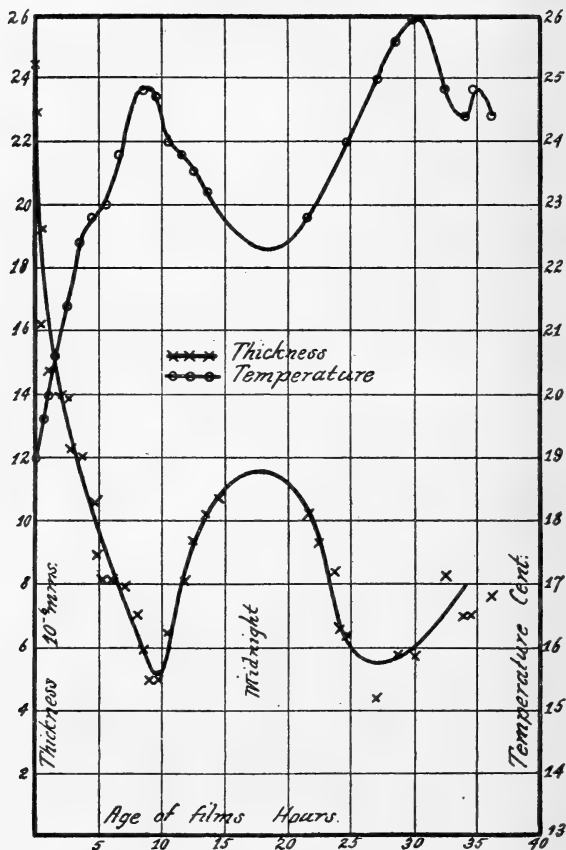

solutions similarly prepared, and even for different sets of films from the same solution. This is shown in the following tables, and may be partially due to irregularities in temperature and rate of thinning, but more probably to the difference in exposure and surface conditions of the solution.

The thinning of the sealed film because of a rise in temperature has an interesting bearing on a demonstration by Warburg*, that the thickness of a very thin film must

* Wied. Ann. vol. xxviii. (1886), p. 399.

diminish with an increase in the pressure of its surrounding saturated vapour. It was assumed, in accordance with Lord Kelvin's* surface-energy principle, that the thickness was so small that the surface-tension diminished with the thickness. As the pressure of the saturated vapour of a liquid increases with the temperature, it would be expected, from this principle, that the film would thin with an increase in the temperature. Whether the thinning is due to this cause or to a loss of water by evaporation from the surface of the films, such as Reinold and Rücker† have shown takes place at the surface of coloured films, seems to be an open question.

The remaining results are given in the following tables. The numbers in the first column indicate the age of the films in hours and minutes; the second, the number of films; the third, the mean thickness in $\mu\mu$; the fourth, the deflexion in fringes of sodium or white light; the fifth, the temperature inside of the casing; while the character of the films is given in the last column. The black film first formed is designated by b_1 and the next by b_2 .

Table I.—This was taken September 9th with a 1 : 40 oleate of soda solution that had been sealed two hours. The films were all thinned to the b_2 films twice by warming a brass plate P (fig. 2), placed above the casing. From inspection of the table it may be seen that the thickness fell in 1 hour to $15\mu\mu$. So long as the temperature was $24^{\circ}6$ it remained constant, and no b_2 films formed. The plate P was then gently warmed, and as a result the b_2 films formed suddenly on all the frames, while the mean thickness dropped to $6\cdot3\mu\mu$. The plate was then removed, and the films all returned to the first black within 10 minutes. The operation was repeated two hours later with the same results. It may be observed that the mean thickness, just before all had begun to thin to b_2 and just as all had returned to b_1 films, was about $15\mu\mu$, while the thickness of the b_2 films was about $6\cdot5\mu\mu$.

Table II.—This was taken September 15th, with a 1 : 70 solution of oleate of soda that had been sealed 24 hours. The deflexion began at slightly over two fringes, corresponding to a thickness of $33\mu\mu$, fell to $20\mu\mu$ in 3 hours, and to $15\mu\mu$ in 20 days. The room was left undisturbed for two weeks. The reading was then (412th hour), as usual, taken before the number of broken films was counted, and gave practically the same mean thickness. Two days later the brass plate was warmed, causing the first b_2 films to appear. The resulting

* Constitution of Matter, p. 179.

† Phil. Trans. vol. clxxii. (1881) p. 486.

thicknesses correspond closely to those in Table I. The limiting thickness of the b_1 films appears here as in Table I. to be about $12 \mu\mu$.

Table III.—This was taken October 13th with a 1 : 70 oleate of soda solution to which 10 per cent. glycerine had been added. The casing had been sealed 24 hours. The most noteworthy feature is the great thickness and its slight increase at the beginning. This increase at the beginning has often been noticed with other solutions. The thickness fell to $28.6 \mu\mu$ at the end of the 6th hour. The brass plate was then continuously heated for an hour while close to the casing, and the thickness fell to 11.5. No further thinning could be produced, even by heating the casing directly with the burner. The plate was then removed, and the temperature fell from $33^{\circ}.4$ C. to 25° , while the films came back to a mean thickness of $35 \mu\mu$. Something similar to the b_2 films appeared on a few of the frames, but was never distinct as with the pure oleate solutions.

TABLE I.

1 : 40 Oleate of Soda Solution ; sealed 2 hours.

Age of Films.		Number of Films.	Thickness. 10^{-6} mms.	Fringes Deflexion.	Temperature. 0° Cent.	Character.
hours.	mins.					
...	...	52	25	b_1
...	2	51	27.6	1.6	24.6	"
...	5	50	21.2	1.2	24.6	"
..	15	49	18.0	1.0	24.6	"
...	30	48	15.5	.85	24.6	"
...	45	47	16.0	.85	...	"
1	5	47	15.0	.80	24.6	"
1	25	47	15.0	.80	...	"
1	45	47	15.0	.80	24.6	"
3	0	44	15.0	.75	24.6	"
3	15	war	med			
3	15	44	13.1	.65	...	$4b_2$
3	16	42	6.3	.30	25.2	b_2
3	20	42	12.6	.60	25.2	$4b_2$
3	25	42	13.7	.65	...	b_1
4	5	42	13.7	.65	24.2	"
4	25	42	13.7	.65	24.2	"
4	45	42	15.8	.75	24.2	"
5	5	41	16.0	.75	...	"
5	5	w	med			"
5	7	41	6.5	.30	25.2	b_2
5	45	36	12.3	.50	24.8	b_1

TABLE II.—1 : 70 Oleate of Soda Solution ; sealed 24 hours.

Age of Films.		Number of Films.	Thickness. 10 ⁻⁶ mms.	Fringes Deflexion.	Temperature. 0° Cent.	Character.
hours.	mins.					
...	...	53	33.4	2.00	22.4	b ₁
3	...	53	20.0	1.20	21.8	"
16	...	53	18.4	1.10	21.0	"
40	...	53	18.4	1.10	21.0	"
68	...	52	17.0	1.00	21.4	"
92	...	51	15.7	.90	21.0	"
111	...	51	15.7	.90	20.4	"
412	...	37	15.5	.65	22.0	"
435	...	37	15.5	.65	21.6	"
455	...	37	15.5	.65	21.0	"
455	...	war med	"
455	3	37	14.3	.60	22.2	"
...	6	37	12.0	.50	22.8	7b ₂
...	7	war med	3b ₁
...	8	37	6.7	.28	22.8	b ₂
...	9	37	6.0	.25	23.0	"
...	16	36	6.1	.25	23.1	"
...	24	36	7.3	.30	22.8	"
...	40	36	8.6	.35	22.6	"
456	5	35	{ 8.8 12.6	{ .35 .50	22	"
...	25	35	12.6	.50	21	4b ₂
457	25	31	14.2	.50	21	b ₁

TABLE III.—1 : 70 Oleate of Soda Solution to which 10 per cent. glycerine was added ; sealed 24 hours.

Age of Films.		Number of Films.	Thickness. 10 ⁻⁶ mms.	Fringes Deflexion.	Temperature. 0° Cent.	Character.
hours.	mins.					
...	...	53	18.0	b ₁
...	2	53	38.4	2.3	18.0	"
...	10	53	40.0	2.4	18.5	"
...	20	53	41.7	2.5	18.5	"
...	55	52	39.0	2.3	19.0	"
1	40	52	38.2	2.25	20.5	"
3	40	52	34.0	2.00	22.0	"
5	40	51	31.2	1.80	22.6	"
7	...	51	28.6	1.65	23.8	"
...	...	war med	"
...	5	51	26.0	1.50	24.7	"
...	9	51	22.5	1.30	25.3	"
...	14	51	17.3	1.00	26.4	"
...	25	51	13.4	.85	28.4	"
...	34	51	12.8	.75	31.0	"
...	40	50	11.5	.65	32.0	"
...	55	50	11.5	.65	33.4	"
8	...	war med	"
...	...	46	14.4	.75	32.0	"
...	25	38	31.4	1.35	26.4	"
10	20	30	35.2	1.20	25.0	"

TABLE IV.—1:70 Oleate of Soda Solution.

Age of Films.		Number of Films.	Thickness 10-6 mms.	Fringes Deflexion.	Temperature, 0° Cent.	Character.
hours.	mins.					
Obs. I.—Freely exposed.						
...	...	52	10.2	.60	25.8	...
...	3	49	6.35	.35	25.8	b_2
...	7	48	6.45	.35	...	"
Obs. II.—Sealed partially, 3 hours.						
...	...	53	16.7	1.00	25.2	b_1
...	10	52	11.9	.70	25.3	"
...	55	51	6.1	.35	26.2	b_2
1	15	51	8.7	.50	25.8	16 b_1
2	...	51	10.4	.60	23.6	20 b_1
Obs. III.—Freely exposed at ends.						
...	...	53	16.7	1.00	24.3	$b_1 b_2$
...	2	53	10.8	.65	24.6	16 b_2
...	37	52	5.9	.35	26.0	b_2
1	17	41	6.5	.30	26.6	"
Obs. IV.—Sealed firmly, 10 minutes.						
...	...	53	16.7	1.00	24.0	b_1
...	35	53	11.7	.70	24.4	2 b_2
4	20	51	7.0	.40	25.6	46 b_2
4	25	war med
4	25	45	5.9	.30	28.0	b_2
4	32	41	6.5	.30	31.0	"
Obs. V.—Sealed firmly, 2 days.						
...	...	53	30.0	1.8	23.0	b_1
...	5	53	21.7	1.3	23.0	"
1	5	53	15.0	.9	24.2	"
3	30	53	15.0	.9	25.1	"
Obs. VI.—Sealed firmly, 4 days; low temp.						
...	...	53	30.0	1.80	18.0	b_1
3	...	52	17.0	1.0	19.3	"
8	...	51	13.9	.8	21.0	"
24	...	48	14.7	.8	19.8	"
Obs. VII.—Sealed 5 days; high temp.						
...	...	53	15.0	.90	29.8	b_1
...	2	53	10.0	.60	30.0	10 b_2
...	10	53	8.3	.50	30.2	20 b_2
2	15	48	12.0	.65	30.0	b_1
6	15	40	15.5	.70	28.4	"

TABLE IV. (*continued*).

Age of Films.		Number of Films.	Thickness 10-6 mms.	Fringes Deflexion.	Temperature. 0° Cent.	Character.
hours.	mins.					
Obs. VIII.—Sealed 6 days ; falling. temp.						
...	...	53	33.4	2.00	18.2	b_1
1	...	53	19.2	1.15	17.5	"
6	...	53	18.4	1.10	17.5	"
Obs. IX.—One side unsealed, 16 hours.						
...	...	53	21.7	1.30	17.2	b_1
...	5	52	13.6	.80	17.2	4 b_2
...	8	51	11.3	.65	17.2	6 b_2
...	28	42	8.4	.40	17.2	20 b_2
1	...	34	7.7	.30	17.4	
1	4	33	6.7	.25	17.6	b_2
Obs. X.—Exposed ; 20 per cent. glycerine.						
...	...	52	29.0	1.70	22.2	b_1
...	10	52	22.0	1.30	22.8	"
1	50	52	22.0	1.30	23.5	"
5	0	49	23.5	1.30	23.5	"

Table IV.—This was taken Oct. 18th and the ten days following on a 1:70 oleate-of-soda solution. The solution was then drawn out and 20 per cent. glycerine boiled with it. Only part of a few of the observations are given, the object being to illustrate the effect of exposure and change of temperature on the thickness of the films.

Observation I.—These readings were taken soon after the solution was prepared, and as soon as it had cooled down to the temperature of the room. The films were freely exposed. Within three minutes the b_2 films had formed on all of the frames.

Observation II.—At the end of Obs. I. the casing was partially sealed and II. taken three hours later. The mean thickness was greater and did not fall so rapidly, though the same might have been the case (judging from other observations) had there been no sealing.

Observation III.—This was taken Oct. 19th, 24 hours later, with the same sealing, and shows about the same thicknesses as in II.

Observation IV.—This was taken Oct 20th, the solution having been firmly sealed 10 minutes when the frames were raised. The second reading gives 11.7 as the limiting thicknesses of the b_1 films. At the end of four hours not all had

become b_2 films, which shows the effect of sealing on the character of the films. But on slightly warming the casing all suddenly became b_2 films at a thickness of $6\ \mu\mu$.

Observation V.—This was taken Oct. 22nd, with the same sealing as in IV. The greater thickness is evidently due to the atmosphere of the films having been sealed for two days.

Observation VI.—This was taken Oct. 24th, two days later, with the same sealing, but at a temperature several degrees lower, and gives practically the same thicknesses.

Observation VII.—This was taken Oct. 25th at a temperature about 10° higher. The fall in thickness may have been partially due to a leaking-in of the air. However, this is a fair example of all observations on pure oleate solutions at high temperature.

Observation VIII.—This was taken Oct. 27th, with a low and falling temperature, and shows a great thickness for over six hours. The thicknesses are about the same as in VI.

Observation IX.—This was taken Oct. 28th after one side of the casing had been unsealed for 16 hours. The fall in thickness even at this low temperature corresponds closely with that of Obs. II., at a higher temperature, taken ten days previously under similar conditions. All the films broke readily into the b_2 films as soon as the lights L and S (fig. 1) were left burning.

Observation X.—This was taken some time later after 20 per cent. glycerine had been added to the solution, and even with the most exposed atmosphere shows a great thickness. No b_2 films appeared. The casing was then sealed, but the solution had become so contaminated that the films broke too readily to permit of any trustworthy readings being made.

Solutions of Different Compositions.—No difference could be observed between the pure oleate-of-soda and oleate-of-potash solutions. The second black film formed under the same conditions, and with the same characteristics, with both solutions. However, with the addition of either glycerine or potassium nitrate the character of the black film was completely changed. When freely exposed or heated, both would show slowly moving eddies of darker regions. When potassium nitrate was added these eddies broke up into tiny flecks moving rapidly about in the film; but never formed in clusters on the frames, as was the case with the pure oleate solutions. While the effect of the glycerine was to increase the thickness of the black film, that of the potassium nitrate was to diminish the range. With an oleate-of-soda solution to which 5 per cent. potassium nitrate had been added, the maximum mean thick-

ness observed was $13.8 \mu\mu$, while for the most freely exposed the minimum was $7.5 \mu\mu$.

Effect of an Atmosphere of Carbon Dioxide.—The effect of introducing an atmosphere of carbon dioxide while the black films were formed was remarkable. The films all suddenly became coloured, and did not again thin to the black film. A thick white precipitate formed on the solution at the bottom of the films and gradually covered the surface. A similar precipitate was often noticed at the bottom of the films, even when the case had been sealed, thus indicating that possibly the atmosphere of the films always contained carbon dioxide.

Conclusions drawn from Results of the First Method.

Considering the observations here given and many others that were made, these conclusions are:—

(1) That the thickness of the black film is independent of the proportions of oleate and water. The truth of this may be seen in comparing the readings in Table I., taken with a 1:40 solution, with those of Tables II. and IV., taken with a 1:70 solution. The same is borne out by many other observations on pure oleate solutions varying in proportion from 1:40 to 1:100.

(2) That the thickness of the black film with a sealed atmosphere diminishes as the temperature rises. This is illustrated in the curve of fig. 4 (p. 508) most clearly. But it is also shown to be true for sudden changes in temperature in the warming process of all the tables.

(3) That the thickness of the exposed black film is ultimately that of the second black, which is constant and independent of the temperature. This is shown by comparison of observations I., II., III., and IX. of Table IV. A number of observations indicated that the thickness of the second black film was not constant. However, as the greatest difference in the deflexion corresponding to a certain number of films was never more than a tenth of a fringe, it is difficult to say whether this corresponds to a real difference in the thickness of the second black film or not.

METHOD II.

The idea of determining the thickness of the black film by measuring the intensity of the light reflected at different angles of incidence was suggested by Prof. Michelson. The measurements were made by comparing the images of two slits at the focus of the telescope of a spectrometer. The light from the slit of the collimator entered the telescope after

reflexion from the film. The other slit was that of a silvered-glass photometer.

Description of the Apparatus.—The photometer consisted of a piece of plate-glass P (fig. 5), lightly silvered on one side with a wedge-shaped silver film and placed behind the

Fig. 5.

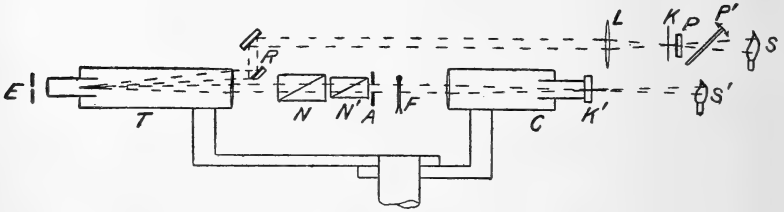

slit K. The sensitiveness was increased by placing at P' a sheet of ground glass which was capable of rotation about a horizontal axis. A lens, L, rendered the rays from S parallel, after which they were reflected through a portion of the objective of the telescope by means of a pair of mirrors, R. Two nicols, N and N', were placed in front of the objective, through which all light reaching the telescope from the collimator passed. A small circular aperture, A, was placed in front of the nicols so as to allow the light to pass through their central portions only. Precautions were taken in observations at all angles of incidence to have the reflected wave-front completely cover this aperture. Another smaller aperture, E, helped in properly placing the eye.

Method of Observation.—The manner of making an observation was as follows:—Set the two nicols parallel; turn the collimator to the angle of incidence at which the reading is wanted; raise the film, F, and turn it until the image of the collimator-slit is close beside that of the photometer. Then, as soon as the black film is formed, adjust the photometer so that both images have the same intensity. The film is then removed, the collimator turned into line with the telescope, and the nicol N turned about its axis until the photometer is again matched.

Theory of the Method.—The intensity of the reflected light is given by the equation

$$I = \cos^2 \theta, \dots \dots \dots (1)$$

where θ is the angle through which the nicol N is turned and I is one half of the light incident on the front nicol N' (neglecting loss due to reflexion). By properly setting the front nicol, the observation may be made with light polarized

in a plane at any angle with the plane of incidence. The error due to an incorrect setting will be a minimum when the light is polarized either in or perpendicular to the plane of incidence.

Airy's formula * expressing the relation between the intensity of the reflected light and the thickness of the film is

$$I = \frac{4b^2 \sin^2 \frac{\delta}{2}}{(1-b^2)^2 + 4b^2 \sin^2 \frac{\delta}{2}}, \quad \dots \dots (2)$$

where b is the coefficient of reflexion,

$$\delta = \frac{4\pi\mu D \cos r}{\lambda},$$

μ the index of refraction in the film, and D the thickness of the film.

Putting

$$A = \frac{\lambda}{2\pi\mu \cos r},$$

$$B = \frac{1-b^2}{2b};$$

and solving the equation for D ,

$$D = A \sin^{-1} B \sqrt{\frac{I}{1-I}}$$

$$= A \sin^{-1} B I^{\frac{1}{2}} = A B I^{\frac{1}{2}}, \text{ approximately}$$

(since

$$D = A B I^{\frac{1}{2}} \{ 1 + \frac{1}{2} \cdot \frac{1}{3} B^2 I + \dots \}$$

and

$$B^2 I < \cdot 008),$$

since in nearly all cases coming into consideration

$$I < \cdot 004.$$

Therefore from (1)

$$D = A B \cos \theta.$$

Since θ is nearly $\frac{\pi}{2}$, it is evident that the thickness D is approximately proportional to the complement of θ .

Method of representing the Results.—Instead of computing

* Undulatory Theory of Optics, p. 53.

the thickness for each observation, the intensity-curves were plotted for a series of curves for different thicknesses of film, but alike in other respects. The observed intensities were then plotted on the same plate. The broken lines on figs. 6 and 7 represent the calculated intensity-curves for light polarized respectively in and perpendicular to the plane of incidence. The constants used in formula (2) for the calculations were

$$\mu = 1.333,$$

$$\lambda = 550 \mu\mu.$$

The intensity-curves for D equal to 5, 6, 7, 8, 9, and 12 $\mu\mu$ are plotted in fig. 6, and 5, 7, and 9 in fig. 7, for angles of incidence varying from 0° to 70° . The abscissæ represent the angles of incidence, while the ordinates represent the fractional part of the light incident on the second nicol N (with the collimator in the zero position), that is reflected from the film.

Statement of Results.—The results of some observations at an angle of incidence of 45° are first given in Tables V. and VI. Two gas-jets were used as sources in Table V., while in all other observations by this method the two sources, S and S' (fig. 4), were two Welsbach burners. The number of the observation is given in the first column and the intensity in the second, calculated from the values of θ in the third. In the last column the thickness is given both in terms of the wave-length and in absolute measure, the wave-length being assumed to be 550 $\mu\mu$.

TABLE V.

Polarized at 45° to plane of incidence; angle of incidence 45° .

Obs.	Intensity.	$\theta - \frac{\pi}{2}$.	D.	
I.	·00106	1·86	$\frac{\lambda}{73}$	10^{-6} mms. 7·5
II.	·00073	1·57	$\frac{\lambda}{88}$	6·2
III.	·00098	1·80	$\frac{\lambda}{77}$	7·1
IV.	·00075	1·56	$\frac{\lambda}{88}$	6·2
			Mean	6·7 $\mu\mu$

TABLE VI.

Polarized in plane of incidence; angle of incidence 45°.

Obs.	Intensity.	$\theta - \frac{\pi}{2}$.	D.	
I.	·00193	2·53	$\frac{\lambda}{77}$	10 ⁻⁶ mms. 7·1
II.	·00187	2·49	$\frac{\lambda}{75}$	7·3
III.	·00247	2·86	$\frac{\lambda}{69}$	8·0
IV.	·00225	2·74	$\frac{\lambda}{72}$	7·6
V.	·00168	2·35	$\frac{\lambda}{85}$	6·5
VI.	·00239	2·39	$\frac{\lambda}{83}$	6·6
			Mean	7·2 $\mu\mu$

Table V.—In this table the plane of polarization made an angle of 45° with the plane of incidence. The first two observations were made April 22nd on a 1:70 oleate-of-soda solution that had stood in the vessel on the table of the spectrometer exposed to the air of the room several days. The last two were taken with a newly prepared solution. The mean thickness is about 7 $\mu\mu$.

Table VI.—This was taken with a similar solution, but with the plane of polarization in the plane of incidence. The mean thickness is about 7 $\mu\mu$.

Continuous readings were then made with a 1:70 oleate-of-soda solution at different angles of incidence. The results are plotted in curves A, B, and C of figs. 6 and 7. Each observation of the intensity plotted is calculated from the mean of ten readings, taken alternately, on opposite sides of the crossed positions of the nicols. A separate film was used for each point. Readings were taken at intervals of 5°, with angles of incidence varying from 22°·5 to 72°·5.

Curve A (p. 520).—This was taken May 11th with a solution that had stood one night exposed to the atmosphere of the room. The intensity of the reflected light corresponds to that from a film whose thickness is about 7 $\mu\mu$. The apparent increase in the thickness at high angles of incidence may have been due to the difficulty in matching the more intense images. The temperature of the room was about 25° C.

Curve B.—This was taken July 12th with a newly prepared solution. Between these readings and those in A the

apparatus had been taken down and entirely readjusted. This may possibly account for the difference in the readings, although it may also have been due to a difference in the solutions. Some of the points lie above a smooth curve through the others, which may be due to imperfect films, as some difficulty was experienced in getting stable films. The thickness of the films is about $6\ \mu\mu$. The temperature of the room was about 23°C .

Fig. 6.

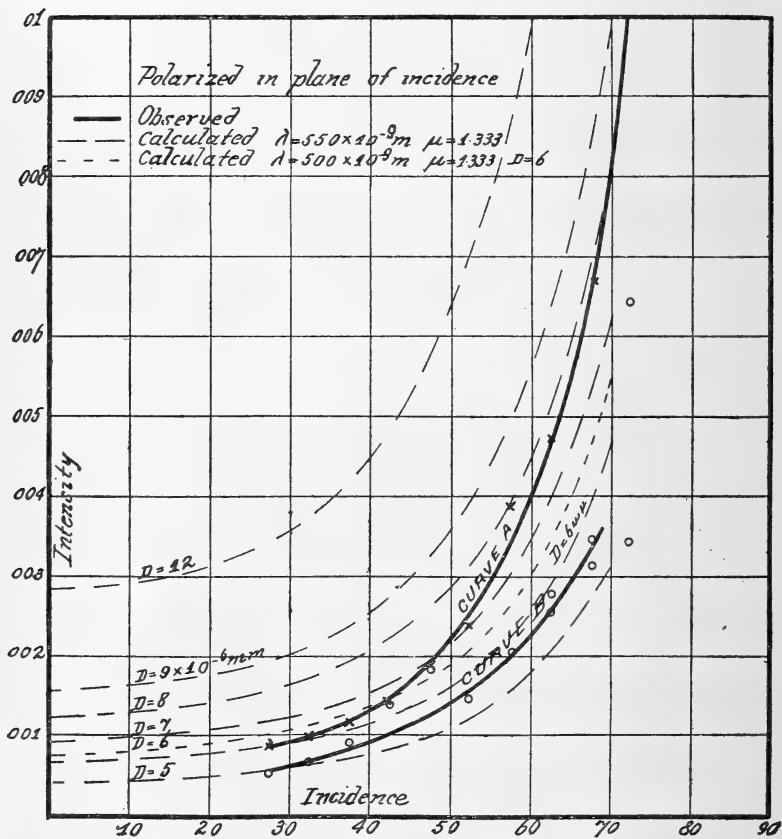

Curve C.—This was taken July 13th, with the same solution as B, that had stood exposed one night. The plane of polarization was perpendicular to the plane of incidence. The intensity fell until the angle of incidence was $52^\circ.5$, at which the image of the collimator-slit could barely be

distinguished. After this for quite an interval no image could be seen. At $57^{\circ}.5$ the image was very distinct. The rise in the intensity was remarkably rapid beyond the polarizing-angle.

The effect of using different values for the mean wave-length in the computed curves is illustrated in fig. 6 by the dotted

Fig. 7.

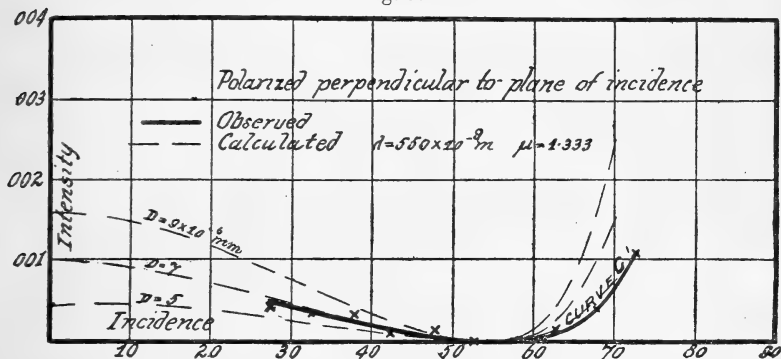

line, which is the computed intensity-curve for D equal to $6 \mu\mu$ on the assumption that λ is $500 \mu\mu$.

Comparison of the two Methods.—The first method offers many advantages over the second. The films could be seen, the temperature of their atmosphere measured, and its hygrometric condition more easily controlled in the first method. But it was not possible to have the films thin at the same rate; hence the readings represent only mean thicknesses. In many cases there was, no doubt, a wide difference in thickness, at any elevation, on different films, and even on the same film.

The film in the second method was 2 cms. by 9 cms., and was exposed at two openings each about a square centimetre in area, and would thus be an "exposed" film.

Probably the most striking feature in the comparison of the results of the two methods is the nearness of the thickness obtained in the second method to that in the first with an exposed film.

It may be remarked that the results of the second method were all obtained before the second black films had been noticed. Although it was impossible to see the second black film in the second method, there can be no doubt but that the first black broke immediately into the second; for such was the case in the first method even when the exposure was ever so much less.

Although the results of the second method correspond to what should be expected from the first, they should probably not be considered to prove more than that the ordinary laws of reflexion hold at the surfaces of such thin films.

Conclusions.—The conclusions to be drawn from the work, briefly stated, are:—

(1) That the thickness of the black film of a soap-solution is not constant, and may vary from $6\ \mu\mu$ to $40\ \mu\mu$.

(2) That the film of a pure oleate solution may consist of two black films, the thickness of the second being about half the limiting thickness of the first, which is about $12\ \mu\mu$.

(3) That the addition of glycerine or potassium nitrate to a pure oleate solution prevents the appearance of the second black film. While in the first case the thickness is greater, in the second the range of the thickness is smaller.

The observations by the first method have been repeated by Mr. Chamberlain; the mean of his results for the thickness of the second black film was $6\cdot2\ \mu\mu$, and for the limiting thickness of the first black film $11\cdot2\ \mu\mu$.

It is here desired to acknowledge indebtedness for many ideas in both methods to Prof. Michelson; and also to thank him for his interest and encouragement in the work, as well as for giving us an instrument so beautifully adapted to work of this character. Many suggestions should also be acknowledged to Associate Prof. Stratton, particularly in regard to the apparatus used. Finally, it is desired to thank Dr. Millikan for suggestions in the preparation of the manuscript.

Ryerson Physical Laboratory,
University of Chicago, March 1st, 1899.

XLIX. *Note on the Source of Energy in Diffusive Convection.*

By ALBERT GRIFFITHS, *M.Sc. (Vic.), A.R.C.S. (Lond.)*.* ✓

AT the conclusion of a paper on "Diffusive Convection" † the author, partly in the hope of producing a discussion, asked certain questions relating indirectly to the source of energy in the apparatus under consideration.

After the publication of the paper in the *Philosophical Magazine*, Prof. FitzGerald made some remarks on it in 'Nature,' and gave a concise account of the actions at work. He pointed out, what was already known to the author, that there is a tendency towards cooling when diffusion causes the rise of the centre of gravity. Stimulated by Prof. FitzGerald's

* Communicated by the Physical Society: read Feb. 24, 1899.

† *Phil. Mag.* s. 5. vol. xlvi. p. 453 (1898).

interest in the work, the author has taken advantage of the Christmas vacation to study the question in some detail.

On the Fall of Temperature when Diffusion occurs upwards if the Solution has a Density greater than that of Water.

Consider a vertical cylinder of length $(l_1 + l_2)$ and sectional area A . Let d_2 equal the density of length l_2 , and d_1 the density of length l_1 . Let it be assumed that there is no change of volume when the two liquids mix.

Taking a plane through the bottom of the cylinder as one where bodies at rest possess zero potential energy, it can readily be seen that before mixing, through diffusion or otherwise, the potential energy

$$= d_2 Ag \frac{l_2^2}{2} + d_1 Ag l_1 \left(l_2 + \frac{l_1}{2} \right).$$

The liquids also possess energy due to the heat they contain.

- Let S_1 = thermal capacity of unit mass of liquid of density d_1 .
- S_2 = " " " " solution " d_2 .
- S = " " " " mixture.
- t_0 = temperature (absolute scale) before mixing.
- t_1 = " " " " after "

The energy, before mixing, in the form of heat equals

$$\int_0^{t_0} d_1 Al_1 S_1 dt + \int_0^{t_0} d_2 Al_2 S_2 dt.$$

The combined potential and thermal energy equals

$$d_2 Ag \frac{l_2^2}{2} + d_1 Ag l_1 \left(l_2 + \frac{l_1}{2} \right) + \int_0^{t_0} d_1 Al_1 S_1 dt + \int_0^{t_0} d_2 Al_2 S_2 dt.$$

Let mixing take place without the addition or withdrawal of heat. Neglecting the heat of combination, the expression for the combined energy now equals

$$\frac{g(d_1 Al_1 + d_2 Al_2)(l_1 + l_2)}{2} + \int_0^{t_1} (d_1 Al_1 + d_2 Al_2) S dt.$$

Equating the two expressions, dividing throughout by A , and rearranging,

$$\frac{g l_1 l_2 (d_1 - d_2)}{2} + \int_0^{t_0} d_1 l_1 S_1 dt + \int_0^{t_0} d_2 l_2 S_2 dt = \int_0^{t_1} (d_1 l_1 + d_2 l_2) S dt.$$

Fig. 1.

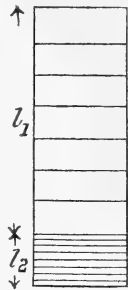

If we make the hypothesis that S_1 , S_2 , and S are constants, then

$$\frac{d_1 l_1 l_2 (d_1 - d_2)}{2} = S(d_1 l_1 + d_2 l_2) t_1 - d_1 l_1 S_1 t_0 - d_2 l_2 S_2 t_0.$$

This equation indicates that $(t_0 - t_1)$, the fall in temperature, depends in some way on the height through which the dissolved substance diffuses. The preceding was worked out long before I published my paper. In what follows, the influence of Prof. FitzGerald will perhaps be shown.

If we wish to study the fall of temperature due to the rise of matter by diffusion in a theoretical manner, we may assume that the capacity for heat of the mixture is the sum of the capacities for heat of the components, and that there is no heat of combination.

Let m = total mass of the two liquids.

s = thermal capacity of unit mass of mixture.

h = rise of C.G.

g = acceleration due to gravity.

f = the fall of temperature.

Then, since the potential energy gained equals the capacity of the liquids multiplied by the fall of temperature,

$$mgh = msf.$$

Hence

$$f = \frac{gh}{s}.$$

It may be pointed out that this equation indicates a limit to the height to which diffusion (with ultimate uniform distribution) can spread. Thus if s be a constant, the above equation holds whatever the fall in temperature; and if the temperature be initially 0° C., f cannot be greater than 273° C., and h cannot be greater than $273 s/g$.

Let $s = 42,350 \times g$ (the capacity of a gram of water), then h cannot be greater than $273 \times 42,350$ cms.; that is 115 kilometres approximately. It may be noted that h is not the height at which diffusion occurs, but the rise in the centre of gravity. In a given case the height at which diffusion occurs can readily be expressed in terms of h .

The Absorption of Heat in a simple case when there is a combination of Diffusion and Motion.

In the figure there is a representation of a vertical tube of length L .

Let us suppose that the lower end is continuously in contact

with an aqueous solution of concentration T , and that its upper extremity is in contact with pure water.

Fig. 2.

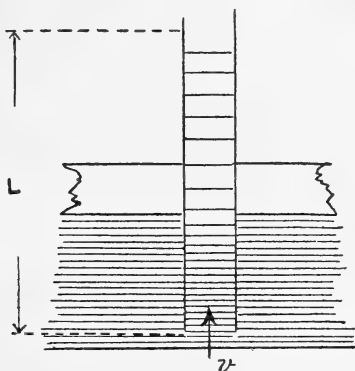

Let v = velocity of liquid up the tube.

A = sectional area of the tube.

With certain assumptions, it is shown in the paper on "Diffusive Convection" that the difference of pressure between the bottom and the top of the tube equals

$$gL + \frac{gTL}{1 - e^{-\frac{vL}{k}}} - \frac{kgT}{v}.$$

The external work done on the cylinder per second equals the product of the volume which crosses any section and the difference of pressure; *i. e.*, it equals

$$\begin{aligned} &vA \left(gL + \frac{gTL}{1 - e^{-\frac{vL}{k}}} + \frac{kgT}{v} \right) \\ &= vAgL + \frac{vAgTL}{1 - e^{-\frac{vL}{k}}} + kgTA. \end{aligned}$$

The work performed per second consists of two parts—

- (1) A quantity of water of volume vA is raised a height L .
- (2) A quantity of dissolved substance (see "Diffusive Convection," Section II.) of amount $\frac{vAT}{1 - e^{-\frac{vL}{k}}}$ is raised a height L .

Let H = the heat absorbed in unit time ; we have :—
external work done — H = work performed : hence

$$vAgL + \frac{vAgTL}{1 - e^{-\frac{vL}{k}}} + kgTA - H = vAgL + \frac{vATgL}{1 - e^{-\frac{vL}{k}}}$$

and

$$H = kgTA.$$

Thus the heat absorbed through the agency of the tube is independent of the height of the tube and of the velocity of flow.

Calculation of the Rate at which Work is done by the Apparatus described in "Diffusive Convection."

Fig. 3.

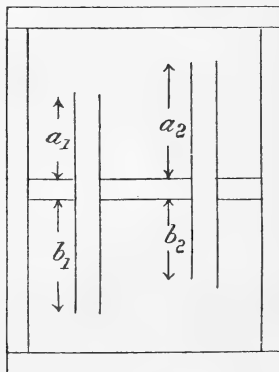

The apparatus to be studied is illustrated in fig. 3.

Let L_1 = length of left-hand tube.

L_2 = " " right " "

A = area of each tube.

c = thickness of the diaphragm.

a_1 = difference of level between the top of L_1 and the top of the diaphragm.

a_2 = difference of level between the top of L_2 and the top of the diaphragm.

b_1 = distance between the bottom of L_1 and the bottom of the diaphragm.

b_2 = distance between the bottom of L_2 and the bottom of the diaphragm.

The work done by the apparatus is equal to the volume which crosses a section in unit time multiplied by what in Section III. of "Diffusive Convection" is called "the pressure tending to produce circulation."

The work done per second equals

$$vA \left[\left\{ gL_2 + \frac{gTL_2}{1 - e^{-\frac{vL_2}{k}}} + \frac{kgT}{v} + (b_1 - b_2)(1 + T)g \right\} - \left\{ (a_2 - a_1)g + gL_1 + \frac{gTL_1}{1 - e^{-\frac{vL_1}{k}}} - \frac{kgT}{v} \right\} \right];$$

or noting that $L_1 = a_1 + c + b_1$, $L_2 = a_2 + c + b_2$, it equals

$$vA \left\{ \frac{2kgT}{v} + \frac{gTL_2}{1 - e^{-\frac{vL_2}{k}}} - \frac{gTL_1}{1 - e^{-\frac{vL_1}{k}}} + g(b_1 - b_2)T \right\}.$$

It may be mentioned that the work done equals zero when $v=0$ (in this case there is an impervious obstruction to the flow); and when

$$\frac{2kgT}{v} + \frac{gTL_2}{1 - e^{-\frac{vL_2}{k}}} - \frac{gTL_1}{1 - e^{-\frac{vL_1}{k}}} + g(b_1 - b_2)T = 0$$

(if $\frac{vL}{k}$ is small), *i. e.* when

$$v = \frac{6k(\overline{a_2 - a_1} + \overline{b_1 - b_2})}{L_1^2 + L_2^2}.$$

(In this case there is no obstruction whatever to the flow.)

The work done by the apparatus is a maximum when v is approximately half the latter value. Work is done on the apparatus when v is negative, or v is greater than

$$6k(\overline{a_2 - a_1} + \overline{b_1 - b_2}) / (L_1^2 + L_2^2).$$

Calculation, by means of Energy Equations, of the Rate at which Work is done.

Before tackling the problem, it will be well perhaps to make some preliminary remarks with regard to what occurs in the upper and lower compartments. The dissolved substance is being continually carried to the top of L_1 , for example, and falling from there to the bottom of the upper compartment. The heat generated by the fall equals the product of the weight transmitted into the fall.

On the other hand, when the dissolved substance is abstracted from the bottom, the weakened solution rises to the top of the lower compartment. Diffusion into the weakened solution, whilst it is rising, will doubtless occur, *but the action*

can be made negligible by taking g very large, in which case the weakened solution rises very rapidly.

If $d=1+t$ (where d =density and t =concentration), it can readily be shown that the heat generated equals the *weight transmitted* into the bottom of the tube by *diffusion* multiplied by the rise of the weakened solution.

The apparatus sketched in the preceding section will now be studied.

The quantity transmitted through L_1 into the upper compartment equals

$$\frac{vAT}{1 - e^{-\frac{vL_1}{k}}}$$

The heat produced by the fall of the substance transmitted to the bottom of the upper compartment equals

$$\frac{vATga_1}{1 - e^{-\frac{vL_1}{k}}}$$

The quantity transmitted into the bottom of L_1 by *diffusion* equals

$$\frac{vAT}{1 - e^{-\frac{vL_1}{k}}} - vAT = \frac{vATe^{-\frac{vL_1}{k}}}{1 - e^{-\frac{vL_1}{k}}}$$

The energy produced by the rise of the diluted solution equals

$$\left(\frac{vATge^{-\frac{vL_1}{k}}}{1 - e^{-\frac{vL_1}{k}}} \right) b_1.$$

Proceeding in this way, and making some algebraic transformations, it can readily be shown that the heat produced in this way when we consider the two tubes equals

$$vAT \left\{ \frac{a_1 + b_1 e^{-\frac{vL_1}{k}}}{1 - e^{-\frac{vL_1}{k}}} - \frac{a_2 + b_2 e^{-\frac{vL_2}{k}}}{1 - e^{-\frac{vL_2}{k}}} \right\}.$$

One effect of the operations just considered is to reduce the quantity of the dissolved substance at the top of the lower compartment by a certain amount, and to place the same amount at the bottom of the upper compartment.

The potential energy gained per second is the product of the weight of the total amount transmitted and the thickness of the diaphragm. Thus the potential energy gained per

second equals

$$g \left(\frac{vAT}{1 - e^{-\frac{vL_1}{k}}} - \frac{vAT}{1 - e^{-\frac{vL_2}{k}}} \right) c.$$

Let W = rate at which work is done by the apparatus
 D = rate at which heat is absorbed due to diffusion along the tubes.

F = rate at which heat is produced by the fall of the dissolved substance in the upper compartment, and the rise of weakened solution in the lower.

V = rate at which potential energy is gained by the carriage of dissolved substance from the bottom to the top of the diaphragm.

Then

$$W = D - F - V$$

$$= 2kATg - vAT \left\{ \frac{a_1 + b_1 e^{-\frac{vL_1}{k}}}{1 - e^{-\frac{vL_1}{k}}} - \frac{a_2 + b_2 e^{\frac{vL_2}{k}}}{1 - e^{\frac{vL_2}{k}}} \right\} - \left(\frac{vAT}{1 - e^{-\frac{vL_1}{k}}} - \frac{vAT}{1 - e^{\frac{vL_2}{k}}} \right) c.$$

Noting that $a_1 + c = L_1 - b_1$, $a_2 + c = L_2 - b_2$, it can be shown algebraically that

$$W = vA \left\{ \frac{2kgT}{v} + \frac{gTL_2}{1 - e^{-\frac{vL_2}{k}}} - \frac{gTL_1}{1 - e^{-\frac{vL_1}{k}}} + g(b_1 - b_2)T \right\}.$$

This is exactly the same result as that obtained in an earlier section.

General Explanation of the Loss of Heat when Work is done by the Apparatus.

For simplicity let the thickness of the diaphragm be zero. Transmission of dissolved substance along the tubes is accompanied by a fall of substance in the upper compartment, and a rise of weakened solution in the lower compartment, both of which actions produce heat. The rate of production of heat depends on the rate of flow of the liquid.

The *greater* the rate at which work is done by the apparatus, the less the rate of production of heat.

The rate of absorption of heat due to transmission of dissolved substance through the tubes is independent of the flow, and need not be considered in this general explanation.

L. *A Study of an Apparatus for the Determination of the Rate of Diffusion of Solids dissolved in Liquids.* By ALBERT GRIFFITHS, *M.Sc.(Vic.), A.R.C.S.(Lond.)**.

SECTION I.

FOR some time the author has been engaged in some experiments with the object of determining the coefficient of diffusion of bodies dissolved in water. It may be some years before experimental results of any decided value are obtained; and perhaps he will be allowed to give an account of the calculations involved, and of the methods he has adopted in obtaining an idea of the probable order of magnitude of the errors to which the apparatus is liable.

The apparatus consists of a vessel V, divided into two compartments, U and L, by a diaphragm through which pass a number of equal vertical tubes of which two only are shown in the figure. Two tubes, A, B, provided with stop-cocks, pass into U. One, A, just enters U; the other passes down to the bottom. Similarly two tubes C and D pass into L; C just enters, and D reaches to the top. The vessel is first completely filled with water, and in the case of a substance which produces an aqueous solution with a specific gravity greater than unity, the tubes A and B are closed, and the solution is passed in through C, the water of L being allowed to escape through D. Diffusion along the vertical tubes now commences, and the compartments U and L are alternately and periodically refilled with pure water and

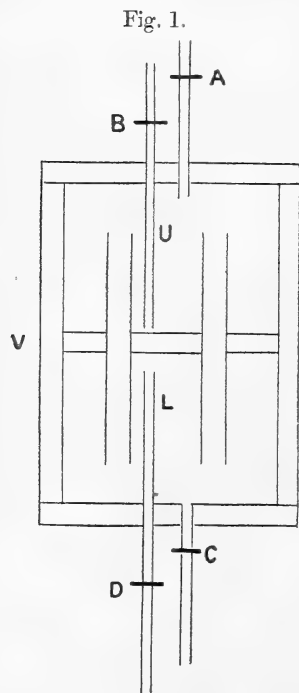

solution respectively. A quantitative analysis is made of the liquid taken from the upper compartment.

SECTION II.—*Calculation of the Coefficient of Diffusion.*

Lord Kelvin has solved the problem of the flow of electricity along a cable possessing appreciable capacity. This

* Communicated by the Physical Society: read Feb. 24, 1899.

solution can readily be transferred to the problem under consideration.

It will be assumed that the upper extremities of the tubes are kept in contact with pure water, and the lower extremities in contact with a solution of constant strength.

Let γ = quantity of dissolved substance which enters the upper compartment in unit time, when the combined sectional area of the tubes equals unity.

k = coefficient of diffusion (C.G.S. system), assumed to be a constant.

L = length of tubes in centims.

T = quantity of substance per c. c. in the lower compartment.

t = time in seconds.

Then

$$\gamma = \frac{kT}{L} \left\{ 1 + 2 \sum_{i=1}^{i=\infty} (-1)^i e^{-\frac{i^2 \pi^2 kt}{L^2}} \right\},$$

where i is any integer.

[If $\frac{L^2}{\pi^2 k}$ log $\frac{4}{3}$ be taken as the unit of time, the topmost of the series of curves given on page 72, vol. ii., of Kelvin's 'Mathematical and Physical Papers,' shows graphically how γ rises to a maximum.]

Let q = total quantity of substance transmitted in t seconds. Integrating the preceding expression with respect to t , we obtain

$$q = \frac{kT}{L} \left\{ t + 2 \sum_{i=1}^{i=\infty} (-1)^i \frac{L^2}{i^2 \pi^2 k} - 2 \sum_{i=1}^{i=\infty} (-1)^i \frac{L^2}{i^2 \pi^2 k} e^{-\frac{i^2 \pi^2 kt}{L^2}} \right\} \quad (1)$$

When t is very large the third term within the brackets may be neglected, and

$$q = \frac{kTt}{L} + \frac{2LT}{\pi^2} \sum_{i=1}^{i=\infty} \frac{(-1)^i}{i^2} \dots \dots \dots (2)$$

or

$$q = \frac{kTt}{L} - \frac{2LT}{\pi^2} \frac{\pi^2}{12} = \frac{kTt}{L} - \frac{LT}{6} \dots \dots \dots (3)$$

The last equation shows that if t is large the quantity transmitted equals kTt/L minus a quantity which is independent of the coefficient of diffusion. Thus if in the adjoining figure abscissæ represent times, and ordinates the quantities

diffused per second, the shaded area between the asymptote and the curve is independent of the coefficient of diffusion.

Fig. 2.

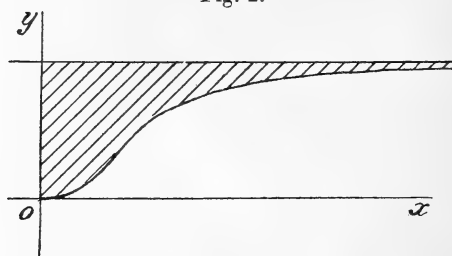

The table below gives an idea of the rate at which the steady state is attained when $L=4.043$, and $k=3 \times 10^{-6}$. The unit of quantity is the amount transmitted per week on the attainment of the steady state.

No. of Weeks.	Total Quantity.	Quantity per Week.
1	0.104	0.104
2	0.703	0.599
3	1.567	0.864
4	2.519	0.952
5	3.505	0.986
6	4.500	0.995
7	5.498	
8	6.498	
9	7.498	
10	8.498	

[The above table gives the *integral* quantities transmitted. The curve already mentioned shows the way in which the rate of transmission varies. The unit abscissa $\frac{L^2}{\pi^2 k} \log_e \frac{4}{3} = 2626$ of a week.]

SECTION III.—*Error due to Differences of Temperature.*

The object of this section is to obtain the *order of magnitude* of the errors produced by differences in temperature between the various tubes.

For simplicity, two tubes only will be considered whose lengths and sectional areas are the same. The expansion of the material of the tubes will be neglected. To make the problem amenable to mathematical treatment, it will be assumed that the density of water equals $(1 - \alpha\theta)$, where θ is the temperature, and α is approximately equal to an ideal coefficient of expansion. It will also be assumed that

$$d = (1 - \alpha\theta + t),$$

where d = the density of the solution,

t = the concentration.

Let θ_1 = the temperature of one tube.

v_1 = the velocity of the liquid up the tube.

θ_2 = the temperature of the second tube.

v_2 = the velocity of the liquid up the tube.

L = the length of each tube, assumed constant.

k = the coefficient of diffusion, assumed constant.

T = the concentration of the solution at the bottom of each tube.

From considerations similar to those adopted in "Diffusive Convection"*, Sect. II. and III., it can be shown that, neglecting viscosity,

$$\begin{aligned} g(1 - \alpha\theta_1)L + \frac{gTL_1}{1 - e^{-\frac{v_1L}{k}}} - \frac{kgT}{v_1} \\ = g(1 - \alpha\theta_2)L + \frac{gTL}{1 - e^{-\frac{v_2L}{k}}} - \frac{kgT}{v_2}. \end{aligned}$$

Dividing throughout by g , and expanding,

$$\begin{aligned} (1 - \alpha\theta_1)L + TL \left(\frac{k}{v_1L} + \frac{1}{2} + \frac{v_1L}{12k} + \&c. \right) - \frac{kT}{v_1} \\ = (1 - \alpha\theta_2)L + TL \left(\frac{k}{v_2L} + \frac{1}{2} + \frac{1}{12} \frac{v_2L}{12k} + \&c. \right) - \frac{kT}{v_2}; \end{aligned}$$

and

$$(v_2 - v_1) = \frac{12k\alpha(\theta_2 - \theta_1)}{TL}, \text{ approx.}$$

* Phil. Mag. Nov. 1898, pp. 453-465.

Now

$$\frac{v_1}{v_2} = - \left(\frac{1 - \alpha\theta_2}{1 - \alpha\theta_1} \right);$$

hence

$$v_2 \left\{ 1 + \frac{1 - \alpha\theta_2}{1 - \alpha\theta_1} \right\} = \frac{12k\alpha(\theta_2 - \theta_1)}{TL},$$

and

$$\frac{v_2 L}{k} = \frac{12\alpha(1 - \alpha\theta_1)(\theta_2 - \theta_1)}{T(2 - \alpha\theta_1 + \theta_2)};$$

similarly

$$\frac{v_1 L}{k} = \frac{12\alpha(1 - \alpha\theta_2)(\theta_1 - \theta_2)}{T(2 - \alpha\theta_1 + \theta_2)}.$$

The correcting factor equals

$$\begin{aligned} & \frac{\left\{ 1 + \frac{1}{2} \frac{v_1 L}{k} + \frac{1}{12} \frac{v_1 L^2}{k^2} \right\} + \left\{ 1 + \frac{1}{2} \frac{v_2 L}{k} + \frac{1}{12} \frac{v_2^2 L^2}{k^2} \right\}}{2} \\ &= 1 + \frac{1}{4} \left(\frac{v_1 L}{k} + \frac{v_2 L}{k} \right) + \frac{1}{24} \left(\frac{v_1^2 L^2}{k^2} + \frac{v_2^2 L^2}{k^2} \right) \\ &= 1 + \frac{3}{2} \frac{\alpha^2 (\theta_2 - \theta_1)^2}{T} + \frac{3\alpha^2 (\theta_2 - \theta_1)^2}{T^2}, \text{ approx.} \end{aligned}$$

As an example, if $(\theta_2 - \theta_1) = 0.1$ C., $T = 0.1$, and $\alpha = 0.00015$, the correcting factor equals 1.00000007.

When T is a small fraction of unity, as in general will be the case, the correcting factor equals

$$1 + \frac{3\alpha^2 (\theta_2 - \theta_1)^2}{T^2}, \text{ approx.}$$

It may be noted that, approximately,

$$v_2 = -v_1 = \frac{12k\alpha(\theta_2 - \theta_1)}{TL}.$$

As an example, let $k = 3 \times 10^{-6}$, $\alpha = 0.00015$, $(\theta_2 - \theta_1) = 0.1$, $T = 0.1$, $L = 4$ cm.

Then

$$\begin{aligned} v_2 &= 1.35 \times 10^{-9} \text{ cm. per second,} \\ &= 0.04 \text{ cm. per year.} \end{aligned}$$

SECTION IV.—Errors due to Changes of Temperature of Apparatus as a whole.

Apart from the effects of any differences of temperature which may exist between the tubes themselves, there will in general be a flow set up along them one way or the other when the apparatus as a whole is heated.

If the upper and lower compartments were of equal volume and the coefficients of expansion and the compressibilities of water and solution were the same, there would be no movement along the tubes; the liquid would simply be compressed slightly. The actual motion could only be calculated from a knowledge of the various coefficients of expansion and the compressibilities. The author has not the data for an accurate calculation, but to give an idea of the order of magnitude of the error, the case will be considered in which the taps of the upper compartment are open.

Let V = volume of lower compartment.
 α = coefficient of cubical expansion of liquid.
 θ = rise in temperature per second.

It will be assumed that the temperature increases at a constant rate, and that the steady state has been attained.

Let v = velocity up the tubes per second.
 L = length of each tube.

Then
$$v = \frac{V\alpha\theta}{A}.$$

The quantity of dissolved substance transmitted per second (see Diffusive Convection, Sec. IV.) equals, when VL/k is small,

$$\frac{kAT}{L} \left(1 + \frac{1}{2} \frac{vL}{k} \right) \text{approx.},$$

$$i. e. \quad \frac{kAT}{L} \left(1 + \frac{1}{2} \frac{VL\alpha\theta}{Ak} \right).$$

As an example, let the rise of temperature be 2° C. per week; let $\alpha = 0.00015$, $L = 4$ cm., $V = 40$ c.c., $A = 0.4$, and $k = 3 \times 10^{-6}$. Then $VL\alpha\theta/2Ak$ equals 0.033 ; and the error due to the flow produced by the expansion is more than 3 per cent.

It may be mentioned that if a bubble of air is present in the lower compartment, it increases the flow, and the corresponding error, considerably.

Even if the upper taps are not left continuously open, there is an error corresponding to the above; for opening

the top taps will allow a sudden rush to take place up the tubes.

It is obvious that a diminution of temperature produces an error in the opposite direction; and the error produced by a fluctuating temperature will probably not be considerable in the long run.

SECTION V.—*Errors due to Changes in Volume produced by the Weakening of the Solution through Diffusion.*

In general, when a solution loses some of the dissolved substance by diffusion it diminishes in volume. The diminution depends on the nature of the dissolved substance and varies with the concentration. The diminution for any given loss can be calculated from a table of densities. For example, an aqueous solution of copper sulphate at a temperature of $23^{\circ}.3$ containing 80 grams to the litre has a density of 1.080, whereas a solution containing 160 grams to the litre has a density of 1.154. It can be readily shown that the addition of 1 gram of anhydrous copper sulphate, between the given limits, on the average increases the volume by 0.075 c.c. approx.

As in Section IV. it will be assumed that the upper compartment is open to the atmosphere.

Since the diminution of volume of the lower compartment equals the quantity of copper sulphate transmitted multiplied by 0.075, with the aid of Sec. I. "Diffusive Convection," it can readily be seen that

$$v = \frac{-0.075 \times T \times v}{1 - e^{-\frac{vL}{k}}}.$$

Hence, neglecting the second and higher powers of $\frac{vL}{k}$,

$$\frac{vL}{k} = 0.075 \times T.$$

Let $T = 0.12$, then $\frac{vL}{k} = 0.009$.

The fractional diminution in the quantity transmitted equals $\frac{vL}{2k}$, i.e. 0.0045. Thus the motion along the tubes causes a diminution in the quantity transmitted by about one half per cent.

With salts whose solutions experience greater changes in volume, the error may be very appreciable.

Thus, between the limits of density 1.081 and 1.159, the addition of 1 gram of sodium chloride causes an average

increase in volume of 0.35 c.c. ; and with $T=0.12$, the error would be 2.1 per cent.

It may be noted that when a small quantity of copper sulphate is added to water, the resultant volume is about the same as the original volume of the water. Hence if the lower compartment were left open to the atmosphere instead of the upper one, there would be no error from the cause under consideration.

As before errors are produced when the taps are opened intermittently.

SECTION VI.—*Errors due to Circulations produced when the Liquids of the Upper and Lower Compartments are renewed.*

When the water in the upper compartment is renewed the pressure at the inlet is greater than the pressures at the outlet, and in consequence the pressures at the upper extremities of the tubes are not constant. Hence flows take place up certain tubes and down others.

Let there be n tubes ; and let $p_1, p_2, \&c.$ be the respective *excesses* of the pressures at the tops of the tubes above the *average* pressure. Assuming the attainment of the steady state, and making the usual approximations, it can readily be shown that the correcting factor equals

$$1 + \frac{12}{g^2 T^2 L^2} \left(\frac{p_1^2 + \dots + p_n^2}{n} \right).$$

Let p_r be the greatest of the p 's ; then the fractional error is less than $12 p_r^2 / g^2 T^2 L^2$. Neglecting inertia effects, the value of p_r must be less than the difference of pressure between the inlet and outlet, an estimate of which could be made practically. The author has not made any practical measurements, but has made a guess as to the order of magnitude of the difference of pressure by making a crude analogy between the upper compartment and a cylindrical tube. Thus, if 100 c.c. of water pass along a tube 3 cm. in diameter in an hour, the difference of pressure (assuming the formula for a capillary to hold) between two points on the axis 3 centim. apart, if we take the coefficient of viscosity equal to 0.01, is 0.004 dyne. Let $p_r=0.01, T=0.1, L=4$, then the fractional error equals

$$12 \times (0.01)^2 / (981)^2 (0.1)^2 \times 4^2, \text{ or } 7.8 \times 10^{-9}.$$

It is clear that the error from this cause is appreciable.

SECTION VII.—*Error due to Diffusive Convection.*

Inequalities in the lengths of the tubes and inaccuracies in placing them in the diaphragm will, in general, produce convection-currents. There is no intrinsic difficulty in calculating flows of small magnitude, if the tubes are of unequal length; but, to simplify the algebra, in the following the tubes will be taken of equal length and of equal sectional area.

Let n = number of tubes.

δ_1 = distance between the top of one tube and the average of the tops of all the tubes.

δ_r = corresponding distance for the r th tube.

v_1 = velocity up the first tube.

v_r = „ „ „ r th tube.

Making the usual assumptions, it can be shown that

$$\frac{(v_1 - v_r)L^2}{12k} = \delta_r - \delta_1.$$

Noting that $\sum v_r = 0$, $\sum \delta_r = 0$, it can readily be shown that

$$\frac{v_r L}{k} = \frac{-12\delta_r}{L},$$

and that the correcting factor equals

$$1 + \frac{12}{L^2} \frac{\delta_1^2 + \dots + \delta_n^2}{n}.$$

With ordinary care in the construction of the apparatus, the correcting factor will deviate very little from unity.

SECTION VIII.—*Some Experimental Results.*

One apparatus has 15 tubes, of average length 4.043 centim., and a total sectional area 0.4102 square centim. It was placed in a cellar the temperature of which fluctuated through a range of about 3° C. per week. The lower compartment contained a solution of copper sulphate holding 0.0506 of copper to the c.c. At intervals of a week the upper compartment was renewed with pure water; similarly the lower compartment was renewed with fresh solution. The tubes were originally full of pure water. The average temperature was about 8° C. By the end of the first week 0.0026 gram of copper had been transmitted; by the end of the second a total of 0.0077; end of third, 0.0144; end of fourth, 0.0226; end of fifth, 0.0311; end of sixth, 0.0403; end of eighth, 0.0559; end of ninth, 0.0662.

Taking as a basis the quantity transmitted in nine weeks, the coefficient of diffusion equals 28.7×10^{-7} . This result, and others not recorded, indicate that the errors due to the various causes studied are, at any rate, not enormous.

To diminish the variations of temperature, in one experiment the whole apparatus was put inside a copper cylinder; but, unfortunately, some air-bubbles were accidentally allowed to form within the compartments, and the quantities of copper sulphate transmitted were irregular and of large value. At present the author is experimenting with the tubes full of a weak gelatine jelly, with the intention, ultimately, of stopping each tube with a short plug of jelly, and thus preventing circulations of all sorts. The plugs will probably be made insoluble with formaldehyde. Mr. Hibbert has helped me with the analyses, and the results are hopeful; but, as already indicated, progress is inevitably slow.

University College, Sheffield.

LI. *The Application of an Interference-Method to the Investigation of Young's Modulus for Wires, and its Relation to Changes of Temperature and Magnetization; and a further Application of the same Method to the Study of the Change in Dimensions of Iron and Steel Wires by Magnetization.* By G. A. SHAKESPEAR, 1851 Science Scholar, Trinity College, Cambridge*.

MUCH work has been done with the object of elucidating the relation between temperature and elasticity, and more remains to be done.

The problem presents many difficulties, not a few of which arise from the fact that it is not easy to maintain at a constant temperature, more or less high, a sufficient length of the material under investigation. Again, very slight differences of temperature between the wire undergoing traction and the scale on which the alteration of length is measured may easily lead to erroneous results.

These difficulties may be lessened by having the length of wire small; but this involves the necessity of some means of measuring accurately very small changes of length; interference supplies such a means. In the present work it has not been found necessary to go to a higher order of accuracy than $\frac{1}{10}$ of the distance between successive interference-bands of sodium light, which represents a length of about $.000003$ cm.,

* Communicated by Prof. J. J. Thomson, F.R.S.

though if required there would be little difficulty in reading to $\cdot 0000003$ cm.

In measuring by interference the relative displacement of two points it is necessary that these points should be connected each with a plane surface, and that during the displacement these two surfaces should remain parallel to each other and sensibly perpendicular to the direction of displacement. Interference-bands are produced between these two surfaces, and any relative tilting would alter the nature of the bands; besides, in case of such a tilt the displacement would clearly be different for different parts of the surfaces.

In the earlier experiments the author used a single rod of the substance (glass in the first place, iron and bronze later), and the extension was measured between one point near the upper end of the rod and another near the lower end, the rod being suspended vertically. To the upper point a clip was attached from which depended a rod of the same material as that under investigation, which supported at its lower extremity a right-angled glass prism with one of the equal faces horizontal and parallel to a plane glass plate, which latter was borne on levelling-screws on a table carried by a second clip at the lower end of the stretched rod. The points of suspension of the rod and of the stretching-weight were arranged so as to be in the axis of the rod (see fig. 1); but in spite of all precautions (though rods were made specially, and as nearly true as possible) it was found that on the application of the stretching-force a relative tilt was produced between prism and mirror, and the centre of the interference-rings was thrown out of the field.

The reason seemed to be the existence of a slight curvature in the rod which was changed by stretching.

The following form of apparatus was then devised:—

Three wires were used, and these were suspended from a horizontally fixed disk of gun-metal, and their lower ends supported a similar disk. Each wire had a T-piece fixed to each end, and these T-pieces moved each in a radial slot in one or other of the disks, the three slots in each disk being at angles of 120° with each other, and by means of radial adjusting-screws these T-pieces could be adjusted at any desired distance from the centres of the disks. Suppose, now (fig. 2), the wires are of equal length and the disks parallel; if on application of the stretching-force they are displaced from parallelism, it is clear that one of the wires

Fig. 1.



(*a*, in fig.) has stretched more than the others, *i. e.* that that wire has had more than its share of the weight. To remedy this the upper and lower ends of *b* and *c* are moved along their respective slots towards the centre, and thus get more of the stretching-force which is applied at the centre of the lower disk, while the upper disk is also suspended centrally. In this way it is easy to adjust the three wires so that, on stretching, the two disks move parallel to each other; and if a rod bearing the prism be suspended from the top disk and the mirror on its levelling-screws be set on the bottom one, the centre of the interference-rings, having been got into the field, will remain there throughout the extension, and the number of bands passing any fixed point in the field will give the amount of extension in half-wave-lengths of the light used.

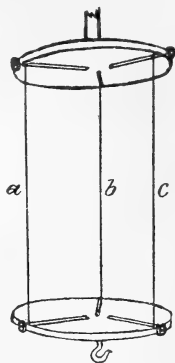

Fig. 2.

In such an arrangement the bending of the disks under the stress would be superposed on the displacement due to stretching of the wires, and in addition any slipping of the wires in the clamps of the T-pieces would affect the observed extension. To obviate any such "end effects" two thinner disks of brass, each with three radial slits just wide enough to admit free passage of the wire, were supported, one near the upper end of the wires and the other near the lower end, each on three clips, which had sharp edges to their hemispherical heads so that the wires should be clipped at well-defined points. From the upper of these the prism-rod hung centrally, and on the lower the mirror rested on three pegs attached to springs by means of which the levelling-screws could give fine adjustment. The coarse adjustment was made by two screws on the prism-rod which moved the prism in altitude in two vertical planes at right angles. The prism-plate and mirror-plate were adjusted horizontally when the clips were put on. Fig. 3 shows a diagrammatic section of the apparatus.

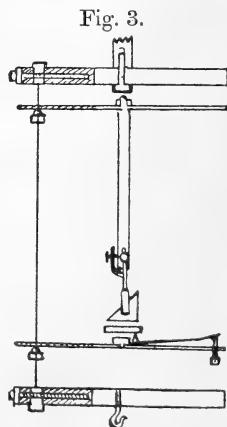

Fig. 3.

Stretching-Force.—It was necessary that the stretching-force should be applied gradually and without vibration. This end was attained by making a hollow cylinder of tin-

plate with conical ends. At the upper apex a steel hook fitted into a screw-stopper of brass; from the lower apex hung a stout brass wire which bore four vanes (fig. 4). The whole hung freely in a cylindrical vessel of tin-plate, and down one side of this vessel passed a tube which opened downwards in the middle of the bottom. When the outer vessel is filled with water up to the level of the suspending hook the weight hanging on the wire depends on the amount of shot placed in the cylinder (by way of adjustable weight). By siphoning out through the tube the water from the outer vessel until the level falls to the lower wire (lower dotted line in fig. 4), a weight equal to that of the water displaced by the cylinder is applied gradually without vibrations. The object of the conical ends is to ensure that the application or removal of the force is begun gradually and without jerk, so that the eye has no difficulty in observing the movement of the fringes from the outset. (The sudden making or breaking of the surface of the water over a flat end sets up perilous vibrations. A similar method which was abandoned in favour of this was the use of a true cylinder suspended in water contained in another concentric cylinder, and the weight applied was got by measuring the fall of water in the outer vessel.)

The vanes are to damp vibrations when the water is at the lower level. An indiarubber tube from the outer vessel led to a tap, whereby the flow of water could be regulated, and from the tap another length of tube passed to a bucket into which the water flowed; by raising this bucket the water could be siphoned back again and the contraction of the wire observed.

Vibrations.—These gave much trouble at first, and necessitated night work. With a view to eliminating this trouble, the work was done in a cellar at the Cavendish Laboratory, and from the floor two piers of masonry were built up; on these stood a massive stand of cast iron (weighing about 3 cwt.) on indiarubber blocks. On the top of this stand (part of which can be seen in fig. 5) a thick disk of cast iron was supported on three levelling-bolts which rested in three V grooves. From the centre of this disk a one-inch steel rod passed down through the top of the stand and supported the

Fig. 4.

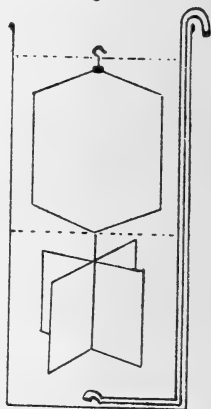
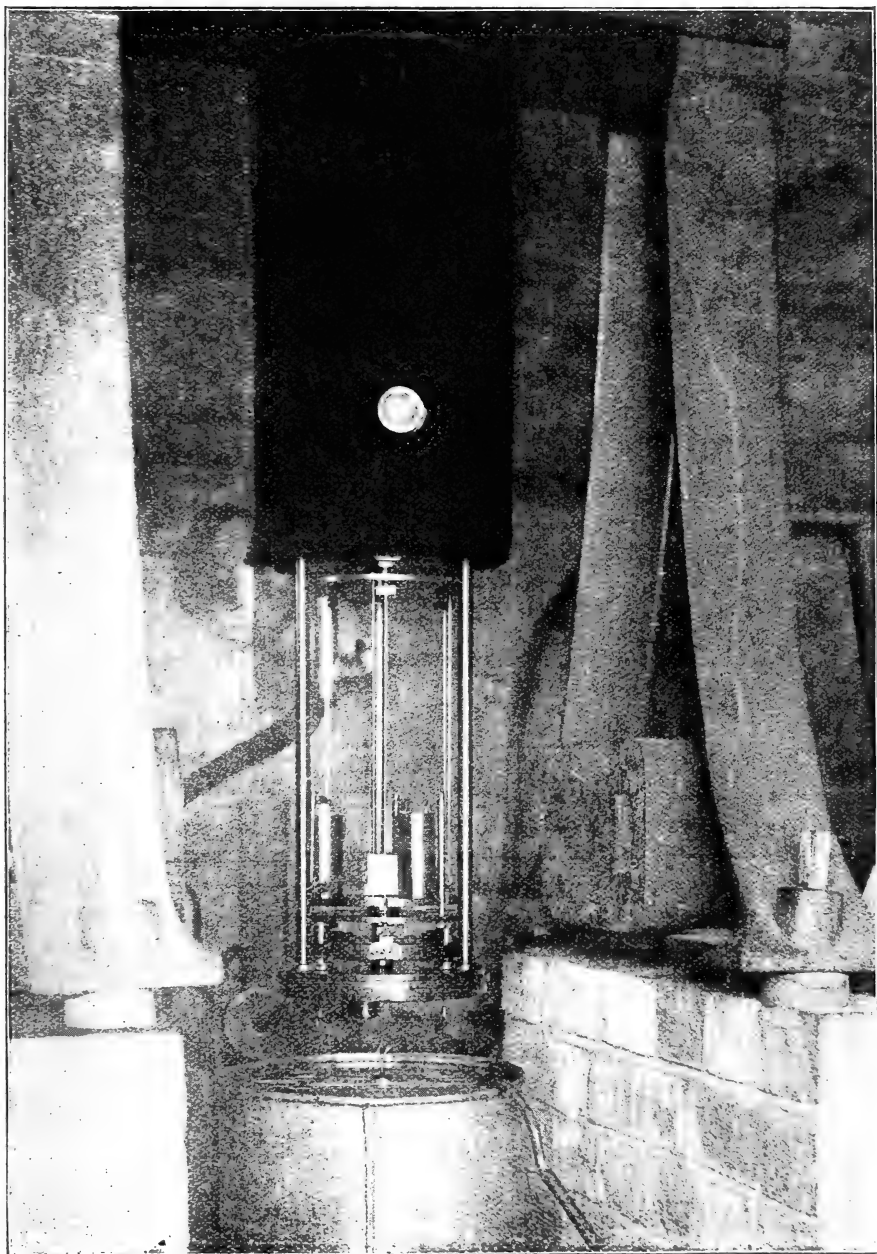

Fig. 5.



apparatus, by means of a central bolt. After this the vibrations seemed as bad as when the apparatus was suspended from a wall-bracket, but the addition of two half-hundred-weights to the stand, and supporting the weight-tank on indiarubber blocks, improved matters, and the further addition to the lower stretching-disk of three vanes which dipped into dash-pots of oil practically removed the trouble, and now, although heavy traffic in the street occasionally causes disturbances, vibrations are so rapidly damped as not to interfere with work.

The apparatus was first used to test the modulus of some copper wire ($\frac{1}{8}$ inch diam.) specially drawn straight (by Messrs. Glover of Salford), and loaded with varying initial loads, beginning with an initial load of 2791 grms. for the three wires—*i. e.* about $\frac{1}{121}$ of the estimated breaking-weight—and proceeding with successive additions of 2 kilos. About twenty observations were made at each stage, the weight producing the extension observed being always the same. It may be remarked here that the stretching-weight above described was standardized by weighing the cylinder directly (on Prof. Poynting's large balance which was kindly put at my disposal) when the water was respectively at the upper and lower levels above mentioned, the temperature of the water being noted. The difference between these weights (at 15°C.) was 5989.50 grms.

The result of this set of observations is indicated in the curve (fig. 6), in which the modulus is the ordinate and the initial load the abscissa. The modulus began at 8.24×10^{11} (c. g. s.) and gradually increased for successive increments of initial load until for an initial load of $\frac{1}{17}$ of breaking-weight it reached the value 1.053×10^{12} , after which it settled down and the curve became sensibly parallel to the load axis as far as the experiments went. On reducing the initial loads again the curve practically went back the same way as it came. Perhaps experiments of this kind may throw light on the discrepancies found by Wertheim between values of the modulus obtained by different methods. It may be pointed out that if the wires were slightly curved, some such effect as that just described might be expected.

Heating.—This was a matter of some difficulty. Stirring was inadmissible on account of vibrations, hence water could not be used. Heating by means of a current of electricity through the wires themselves was out of the question; for (1) the current itself apparently affects the elasticity, and (2) the heating would tend to be patchy owing to differences in radiating power of different parts of the surface

of the wires. By using No. 20 B.W.G. wire the length employed was satisfactorily reduced to 10 cm. This was enclosed in a chamber of thick copper, and heating was attempted by means of a flat platinum coil at the bottom, but this was unsatisfactory and was abandoned—probably on account of convection-currents.

Fig. 6.

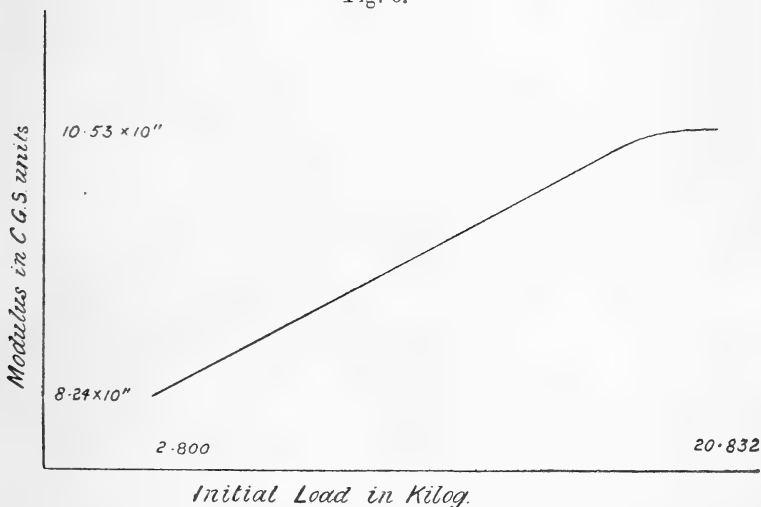

The method finally adopted was one in which the constancy of boiling-point of a liquid at a definite pressure is made use of. This involved some changes in construction of the apparatus, the final form of which will now be described.

Fig. 7.

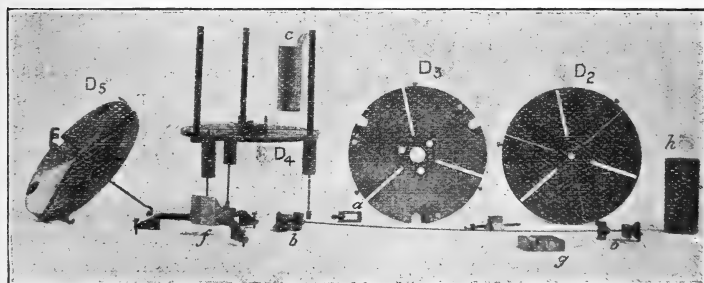

At the top and bottom are the two stretching-disks D_1 and D_5 (see fig. 7, D_1 is not shown), of gun-metal, $5\frac{1}{2}$ inches in diameter and $\frac{1}{2}$ inch thick, each with three radial slots of

cross-section shown in fig. 8. In the centre of each disk is a hole, that in D_1 for the suspending bolt and that in D_5 for the hook which supports the weight. In each slot slides a movable piece $\frac{1}{2}$ inch long, and of section shown in fig. 9, with two holes

Fig. 8.

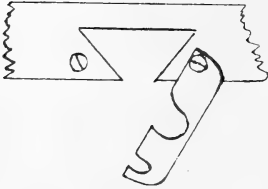

Fig. 9.

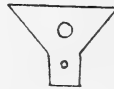

Fig. 10.



through its length: the larger one admits the radial adjusting screw; into the smaller one an end of the wire to be tested fits (bent at right angles), and is clamped there by a brass clamp (*a*, fig. 7) fitting over the free part of the sliding-piece. The head (fig. 10) of the radial screw is squared to fit a clock-key and has also a pulley-groove in it; into this groove, when the sliding-piece is in position, the hinged piece of flat brass, shown in fig. 8, fits and is then secured by the small screw shown on the other side of the slot. In this way the radial screw, unable to move backwards or forwards, is able to move the sliding-piece along the slot.

Next below this comes the prism-suspending disk D_2 , with three narrow radial slits just wide enough to admit No. 20 B.W.G. wire freely; this is supported on the three upper clips. Each clip is made of brass with a hemispherical head of steel, the latter consisting of two sharp-edged jaws which can be screwed together (two of these clips are shown in position on wire in fig. 7, *bb*).

Near each of these radial slits in D_2 is a small hole into which a screw from the edge passes. From these holes pass wires of the same material as that under investigation, to support D_3 on which the prism-stand itself rests. D_3 has three large notches in its edge, and through these rise, without touching, the pillars from D_4 , which bear vanes (one of which is shown in position in D_4 , *c*, fig. 7) to dip into three corresponding dash-pots which stand on D_3 . Near the centre of D_3 are three large holes to admit, without contact, the three levelling-pegs of D_4 , on which the mirror rests. The prism-stand (*f*, fig. 7) carries the prism over the surface of the mirror (*g*), and is provided with three levelling-screws as feet for coarse adjustment. D_4 is the mirror-plate with three radial slits, it rests on three clips. It has the mirror supports, which are provided with a fine adjustment consisting of three radially

disposed tapering springs of brass clamped at their thick ends by a central circular washer (fig. 11). Each spring close to

Fig. 11.



the washer bears a peg for the support of the mirror; and under the point of the spring rises the levelling-screw, by moving which up or down the peg itself is very slightly raised or lowered. These levelling-screws are long and are surrounded below the plate for about half their length by brass tubes (see fig. 7) which when the instrument is in use pass freely through the large holes near the edge of D_5 and dip into annular troughs on the upper side of the lower box of the vapour-jacket (see diagrammatic section fig. 12), while the screws themselves pass out through the box.

Fig. 12.

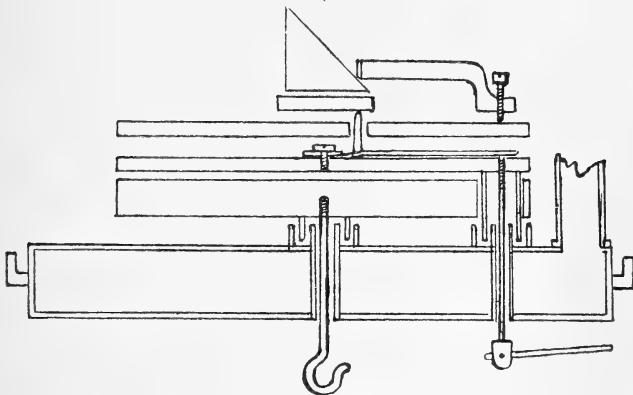

The troughs are filled with oil into which the ends of the tubes dip. The object of these oil-joints is to allow of free communication with the exterior, while at the same time preventing any influx of cold air, without impeding the free movement of the disks when the wires are stretched. The weight-supporting hook from the middle of D_5 passes out through a similar oil-joint. (Fig. 12 will make clear the relations of these parts.) It must be observed that D_3 and D_4 are quite independent of each other, their only connexion being by means of the dash-pots, no metallic contact existing. The

vane-pillars are bolted to D_4 , and at their upper ends are screws for the attachment of the cylindrical vanes. A dash-pot is shown at *h*, fig. 7.

The vapour-jacket is in two parts, an inner and an outer. The inner consists of two flat cylindrical boxes lying horizontally, and vertically underneath one another, connected by three vertical tubes. The top box is pierced by three tubulures for the thermometers, the bottom one has four for levelling-screws and weight-hook. There is a large inlet for vapour at the top of the upper box, and an outlet at the bottom of the lower box. The steel supporting-rod extends through a tube in the centre of the upper box (on to a felt washer), and D_1 is bolted firmly to it and against the lower face of the upper box (see fig. 13). An annular trough

Fig. 13.

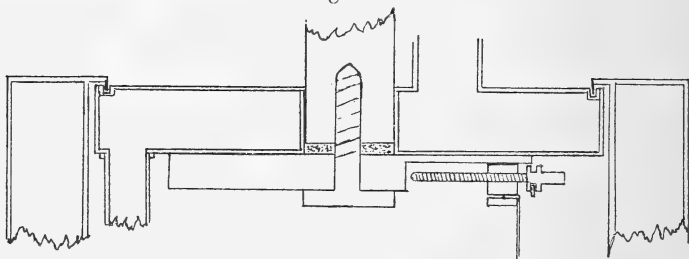

round the edge of this box receives a flange from the upper extremity of the outer part of the vapour-jacket, and a little oil makes the joint draught-proof.

The outer part of the jacket is simply a pair of concentric cylinders of brass, with an inlet at top and outlet at bottom, the annular space being closed in at both ends. The inner cylinder projects at its base in a flange, which dips into a trough on the outer edge of the lower flat box. There is a double window of glass, at a suitable height, through the outer jacket to allow of viewing the bands in the prism. When in use the jacket is covered with felt. In putting in fresh wires the outer jacket is raised, as in fig. 5, coarse adjustments are made, and the bands got to a good clear state, and then the outer jacket is lowered again into position.

From the boiler a pipe passes to the inlets of the two parts of the jacket, and from the outlets another pipe passes through a condenser to the boiler, giving off below the condenser a small tube, which is connected with a manometer, air-reservoir (a glass bottle of about 2 gallons capacity), and water-pump.

It was found that the boiling of the water shook the apparatus. To remedy this two vertical joists were screwed to the wall side by side, about three inches apart, each carrying two elbow-pieces of the steam-pipe; the upper pair were connected by a short piece of thick india-rubber tube, and the outer ends were similarly connected to boiler and delivery-pipe, another india-rubber joint intervening between the latter and the jacket. The lower pipe was similarly supplied with these indiarubber joints, the nature of which is shown diagrammatically in fig. 14.

Fig. 14.

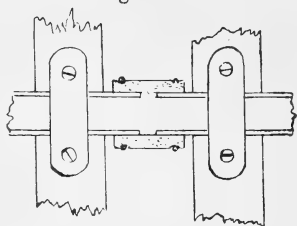

Even so, after the water had been boiling for some hours, the "bumping" caused vibrations, but this was stopped by putting into the water some fragments of pumice.

By adjusting the pressure by means of the water-pump the water was boiled at different temperatures between 45°C . and 100°C ., and the apparatus was kept at constant temperature within the jacket for any length of time, at least the three thermometers remained stationary. For lower temperatures alcohol serves. At present little use has been made of intermediate temperatures, as the results of observations at 13°C . and 100°C . respectively have given so much material for consideration.

The source of light is a sodium flame placed behind an aperture in a screen at the focus of a convex lens; the parallel beam thus obtained is reflected by a mirror at an angle of 45° into the prism, and through an aperture in the silvering of this mirror the fringes are viewed along the path of the incident light. The lower of the two equal faces of the prism is half-silvered, and is adjusted about .25 mm. above and parallel to the fully-silvered upper surface of a glass plane; both plane and prism were specially worked by Hilger. Between the light from these two silvered surfaces the interference is effected, part of the pencil of light being reflected from the lower face of the prism and part from the upper face of the mirror, the relative retardation depending on their distance apart.

Results.—We may now consider the results of some of the observations on (1) copper, (2) soft iron, (3) "silver" steel, and (4) hard brass.

As we are only concerned with changes in the elasticity it

will be unnecessary to give the actual modulus in each case, but the figures denoting the extension or contraction in half wave-lengths of sodium light will be quoted where necessary. The length of wire used is about 28 cm. (28·15 to 28·30 for different specimens), diameter about ·075 cm. (·0690 to ·0810). It must be understood that the weight applied in all cases is the same.

In all cases the effect of putting on and removing the weight, and of raising the temperature and letting it fall again, has been to increase the modulus, *i. e.*, the observed extension is always greater at the beginning of operations on any specimen than it is at the end. As examples: a specimen of copper at the beginning showed an extension of 317 bands, whereas at the end of the series of observations the elongation for the same load had settled down to be constantly only 279—an increase of about 12 per cent. in the modulus. Similar figures for a specimen of soft iron are 178·6 and 175·9, say an increase of 1·5 per cent. A specimen of silver-steel gave 149·1, falling to 143·7, or an increase of 3·6 per cent. A specimen of brass gave 315·3 to 293·7, or an increase of 6·8 per cent.

In all cases the change of modulus produced by change of temperature from 13° to 100° showed much variation at first, the effect of the first heating being that the modulus was greater at the higher temperature than at the lower, but after this an increase of temperature decreased the modulus.

The following are some characteristic figures for a specimen of copper:—

	Temp. 13°.	100° C.	Percentage <i>decrease</i> of modulus.
No. of bands:	317·0	303·0 (1st heating)	—4·4
	291·8	298·5 (2nd ")	+2·3
	287·5	296·4 (3rd ")	+3·1
	283·0	293·7 (4th ")	+3·8
	279·2	289·4 (5th ")	+3·7
	278·0	287·5 (6th ")	+3·4
	278·5	289·0 (7th ")	+3·8
	279·0	289·0 (8th ")	+3·6
	279·0	289·0 (9th ")	+3·6
	279·0	on finally cooling.	

These figures show a gradual settling down to a steady state.

Similar figures for soft iron are :—

	Temp. 13°.	1000° C.	Percentage decrease of modulus.
No. of bands:	178·3	176·5	— 1·00
	176·4	178·3	+ 1·07
	177·1	175·3	— 1·01
	173·1	179·6	+ 3·75
	176·3	178·3	+ 1·14
	176·4	179·2	+ 1·58
	176·5	178·5	+ 1·13
	175·6	178·5	+ 1·65
	175·8		

The specimen of steel referred to above gave :—

No. of bands:	149·1	148·0	— 0·74
	144·4	148·3	+ 2·7
	143·6	148·3	+ 3·3
	143·5	148·2	+ 3·3
	143·4		

Similarly, for hard brass :—

No. of bands:	315·0	310·5	— 1·43
	297·0	303·7	+ 2·25
	293·7	302·7	+ 3·06
	292·8		

Hence in all cases the final value of the modulus was lower for the higher temperature than for the lower : viz. 3·6 per cent. for copper, 1·6 per cent. for iron, 3·2 per cent. for steel, and 3 per cent. for hard brass. It is interesting to note that, with the exception of the brass, these figures are in the same order as those given above for the increase of elasticity from beginning to end of observations on each specimen.

In almost all cases after any change of temperature, or after a rest (of any time more than half an hour, say), the first observation of the series showed an amount of elongation different from those given by succeeding observations of the same series, the first elongation generally being greater than those succeeding.

The following numbers are taken from results of observations on soft iron :—

First Elongation.	Succeeding Elongations.	Percentage Change.
180·0	176·5	— 1·94
180·0	176·4	— 2·0
176·7	176·3	— 0·22
179·9	179·5	— 0·22
180·0	178·8	— 0·66
179·5	177·7	— 1·0

Another effect to be noticed is that, in the case of steel and brass at least, after the weight had been left on for some hours, in the succeeding observations the "up" numbers (*i. e.* contraction on removing load) exceeded the "down" numbers (*i. e.* extension on putting on load), and after the weight had been left off for a length of time the "down" numbers were greater than the "up," as though in the former case the wires were gradually recovering and in the latter case gradually yielding slightly. It may be remarked here that no gradual yielding was observable when the load was kept on. (The load was about 2 kilos to each No. 20 B.W.G. wire.) In the case of copper the "up" readings showed a tendency to be greater than the "down" throughout. No such tendency was observed either way in the soft iron.

If the weight was left on for some time the modulus was, in general, temporarily affected—decreased in the case of copper, increased in iron; but in the latter metal if the load was left on at 100° C. for several hours and then observations made, and a rest of about half an hour allowed with the weight off, on resuming observations there seemed to be a tendency, after the first two or three extensions, to a sudden decrease of the modulus of about 1 per cent. (this occurred on several occasions). Generally, at each change of temperature eight or ten observations were made, of which the above quoted figures are examples.

During the delay caused by waiting for the construction of the heating-apparatus, some experiments were made on various magnetic effects on iron wires. The form of apparatus above described was modified for the purpose. Three similar solenoids were made, one for each of the three wires, and an electric current was sent through them in series.

Observations on the effect of a magnetic field on the elasticity were not quite satisfactory (these are being repeated under more favourable conditions at the present time); there seemed, however, to be an undoubted decrease in the modulus on putting on the magnetic field.

Other experiments were made, at some length, on the changes in length produced by magnetization in iron and steel wires under different stresses.

For these experiments the wires were 75 cm. long, and the solenoids extended all their length. The number of turns in each solenoid was 1390 and the resistance 1.21 ohm; a current of one ampere would thus produce a field of about 23 c.g.s. units. The interference-bands in this case were got by transmitted light, the upper plate being supported by a tube from the upper disk.

The solenoids were wound on brass tubes, down the centre of each of which passed a concentric inner tube, leaving an air space of about 4 mm. all round, and the wires examined passed along the axes of these inner tubes; this was to reduce the effect of heating due to the current in the solenoid, and in addition air was constantly pumped through this space.

The current was started at practically 0 (by a potentiometer method), and rapidly increased to 2 amperes; then reduced to 0, reversed, and taken up to 2 amperes again and returned to 0, completing a cycle.

In general, for iron wires with only a small load, the first effect was a contraction, followed by an expansion as far as the current was increased (*i. e.* up to 2 amperes); on decreasing the current a further lengthening took place, till a turning-point was reached, and then contraction set in, and continued till the current reached 0; after reversal the first effect was a continued contraction, then a turning-point was passed, and expansion ensued till the current reached a maximum, and on decreasing the current the expansion increased until the same turning-point as before was reached, after which there was a contraction till the current fell to 0.

For heavy loads the effect was very different, and consisted of a contraction till the current reached its maximum and an expansion afterwards until the current reached 0.

It seems somewhat strange that in the former case expansion should result from an increase in the field, and also from a decrease after the current has reached a maximum, and the idea naturally occurred that it might be due to a rise in temperature; that this, however, is not the case, seems to be shown by the fact that, while elongation due to heating (by the solenoid) can be seen to take place slowly and uniformly, this effect on the other hand is produced immediately on changing the current, and stops the instant the decrease or increase of current is stopped. Moreover, on stopping the change of current no gradual contraction was observed, so that the effect is presumably not due to heating by Foucault currents. The amount of this extension did not appear to depend on the *rate* at which the field was changed. Hard pianoforte-steel showed, even with small loads, a contraction on magnetization and an elongation on reducing the field, behaving in fact very much as heavily loaded iron.

The following are examples of cycles taken at random from the results of about 600 observations. The load is the actual load in grms. which was supported by the three No. 22 B.W.G. wires; the current at the turning-points is given in amperes and the elongations are given in half-wave-lengths of sodium light; + indicates elongation, - shows contraction.

TABLE A.

	Load in grms.	First effect.	Turning-point (current in amperes).	Increase after turning-point to 2 amperes.	Increase after 2 amps. to 2nd turning-pt.	2nd turning-point.	After 2nd t.-p.
Current reversed }	2500	-2.1	.17	+12.5	+1.5	.66	-8
	...	-1.2	.13	+11.5	+1.5	.59	-6
"	6000	-3	.8	+8	+1.0	.55	-1.1
	..	-2	.7	+7	+1.0	.58	-1.2
"	10500	-3	1.4	+2	+1.1	.35	-3
	...	-3	1.4	+2	+1.1	.35	-2
"	21000	0	0	-6	+8	0	0
	...	0	0	-7	+1.0	0	0

These are all taken from a specimen of soft iron.
Another specimen showed the following:—

TABLE B.

	Load in grms.	First effect.	1st turning-point.	2nd effect.	2nd t.-p.	Increase to 2 amps.	2 amps. to 3rd t.-p.	3rd t.-p.	After 3rd t.-p. to 0.
Current reversed }	9,400	-1	.19	+3	1.3	-1	+2.5	.39	-1.8
	...	-1	.18	+3	1.2	-1	+2.5	.32	-1.5
"	20,000	-8	.17	+2	.57	-2	+2.7	.07	-1
	...	0	0	0		-5	+3.8	0	0

The following is from pianoforte-steel results:—

TABLE C.

	Load in grms.	First effect.	1st turning-point.	2nd effect.	2nd t.-p.	Increase to 2 amps.	2 amps. to 3rd t.-p.	3rd t.-p.
Current reversed }	4,500	+5	.51	-3	1.9	+7	+5.5	.22
	...	+6	.52	-3	1.9	+2	+3.4	.21
"	20,000	+1	.56	-3.5	2		+4	
	...	+1.1	.61	-3.0	2		+4	

In fig. 15 the two types of field-elongation curve are given for a cycle through the range of field used in the above experiments, viz., from +47 to -47 c. g. s. units. The ordinates are elongations of the wire expressed in half wave-lengths of sodium light, the abscissæ give the current in the solenoids in amperes, and are therefore proportional to the field. The continuous line is the curve for a specimen of soft iron with a load of 3000 grms. on the three No. 22 B.W.G. wires; the dotted line is the curve for hard pianoforte-steel with a load of 20,000 grms. In each case the left half of the curve is higher than the right, which may possibly be due to a rise of temperature during the experiment, perhaps due to hysteresis.

Fig. 15.

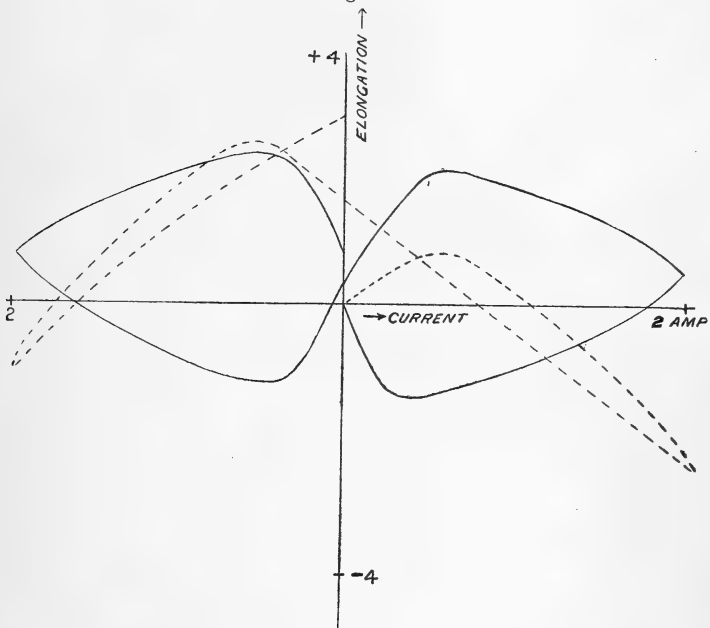

The second cycle in Table B is interesting; it shows that for that load the wire is in a transition state, and for the lighter loads the state of affairs is similar to that indicated in the upper half of the cycle, while for heavier loads the type of curve is that given by the lower half.

It will be noticed that in the above examples the elongation is considerably greater than the contraction, so that the net result of a cycle is an elongation. This might be due to a gradual rise in the temperature, owing to the heating of the solenoids, or it might mean that the fact of reversing the

current makes the wire yield to the stress. (The apparatus is now being modified to avoid heating-effects, and it is hoped that any irregularities due to that cause will be removed.)

It seems reasonable to suppose that if the act of magnetization and demagnetization causes the wire to yield to the stress, then on applying an alternating current to the solenoids a considerable elongation would result; this was accordingly tried, and the immediate effect was an elongation, but as soon as the current was stopped the wire steadily contracted to its original state. The elongation began rapidly and then slowed down, and finally stopped, while the current was still on. This elongation seems to have been due to the heating effects of hysteresis, for on substituting copper wires for the iron no such effect occurred.

This suggested an interesting method of getting the area of the hysteresis-loop. The alternating current is put on and the elongation measured by counting the bands which pass until the latter have come to rest. Then a current (C) is passed down the wires themselves until a steady elongation of the same amount is produced. Then if we assume that the energy supplied in the two cases to the wires is the same, and we know the number of alternations per second, n suppose, of the current in the solenoids, we can put

$$ln \int H dI = C^2 R = CE,$$

where $\int H dI$ is the energy dissipated at each cycle of magnetization, l the length of the wire, and R is the resistance of the wires.

The following is an actual example for soft-iron wire:—

$$C = 1.2 \text{ amp.},$$

$$n = 80,$$

$$E = 2.5 \text{ volts},$$

$$l = 75 \text{ cm.},$$

$$\therefore \int H dI = \frac{1.2 \times 10^8 \times 2.5}{10 \times 80 \times 75} = 5000 \text{ ergs.}$$

This neglects the heating due to Foucault currents, which could be reduced by lamination, though the absence of such elongation in copper wires seems to show that the heating due to this cause is not very considerable compared with that due to hysteresis. (But of course in copper the Foucault heating would be only $\frac{1}{\mu}$ of that in iron wire.)

In conclusion I wish to thank Prof. J. J. Thomson for valuable criticism and kindly interest, and Prof. Poynting for encouragement and suggestions; also Mr. A. Goodliffe, of King's College, for kind assistance in some of the observations, and Mr. W. G. Pye, of the Cavendish Laboratory, for help in construction of the apparatus.

LII. *Denudation and Deposition.*—Part II.
 By G. JOHNSTONE STONEY, M.A., D.Sc., F.R.S.*

77 JJ

1. **I**N the May number of the Philosophical Magazine Dr. Charles Chree comments upon a paper in the preceding number, in which the present writer suggested that Denudation and Deposition have probably taken a large part in increasing and rendering permanent the elevations on land and some of the depressions in the ocean which are found to prevail over the earth. In reply to Dr. Chree's criticisms it seems sufficient to call attention to the facts of nature with which we have to deal, distinguishing those about which we are justified in feeling confident from others of which we can only affirm that they are probably what we suppose them to be. To emphasize this distinction, the qualifying terms *certain* and *probable* will in the following paragraphs be applied to such facts of nature, or supposed facts, as we have occasion to refer to. It will thus be seen that our information about the compressibility of the earth is dependent almost exclusively upon the known facts.

2. It seems *certain* that the volume of a body of any given material when it is compressed equally in all directions, depends, so long as it does not undergo a change of state, only on the temperature and pressure : that in fact,

$$v = f(t, p),$$

where v is its volume, t its temperature, and p the surface-pressure to which it is exposed. The body is supposed to be of such moderate size, that the variations of pressure arising from gravity need not be taken into account. From this expression we obtain the following expression for k , the coefficient of compressibility when the body is subjected to a small increase of pressure without changing its temperature—

$$k = \frac{\partial v}{\partial p} = f'(t, p),$$

where f' is that function of t and p which is got by keeping t constant and differentiating f by p only. We thus see that for each kind of material *the coefficient of compressibility is a function of the temperature and pressure.*

3. The circumstance that the mean density of the earth is only about $5\frac{1}{2}$ times that of water, which we may take as *certain*, supplies us with information which has significance in our inquiry. The so-called solid part of the earth, by which is to be understood the earth minus its atmosphere and

* Communicated by the Author.

ocean, *certainly* consists of superficial layers which are almost exclusively oxygen salts, and of a great underlying centrosphere about which we know little. The oxygen salts have, at the surface of the earth, densities which range between two and three times that of water, and in forming them, along with that liquid oxygen salt which we call the ocean, nearly all the oxygen upon the earth is *certainly* used up. In proof of this statement see the paper on p. 565 of this number of the Phil. Mag., from which it appears that the free oxygen is *certainly* an exceedingly small proportion of the earth's stock of oxygen, *probably* much less than a ten-thousandth part. It is further *probable* that the whole would now be used up in forming the oxygen salts, were it not for the ease with which heat and chemical agencies evolve carbon dioxide from the carbonates, and the fact that the energy that reaches the earth from the sun enables vegetation to evolve free oxygen over the earth's surface from the carbon dioxide so produced. This enables a very small proportion of the whole stock of oxygen to present itself at any one time as free oxygen in contact with the outer boundary of the lithosphere. From these considerations joined with others, it seems *probable* that the oxygen salts form only a superficial crust—perhaps having a thickness something like $\frac{1}{250}$ of the earth's radius—over a relatively vast mass of deeper-seated materials, which *probably* are not oxygen salts. In fact it is *probable* that the great interior of the earth is for the most part something intermediate between an alloy of various metals and a mixture of them; whence it is *probable* that the materials of which it consists would, if those materials were brought to standard temperature and pressure, have an average density more than twice that of the layer of oxygen salts. They are, however, far from being at either standard temperature or pressure. What is *certain* about them is that these materials are such and so circumstanced that the mean density of the earth is little more than twice that of the film of oxygen salts over its surface. The more deeply-seated materials are *certainly* compressed by enormous pressures increasing downwards, and are also as *certainly* so dilated by the temperatures to which they are exposed, that notwithstanding the extreme intensity of the compressions, the counteracting expansions are great enough to bring down the average of all the densities to the very low value of 5.5 times the density of water.

4. Another fact which I think we may regard as *certainly* known, is that wherever there prevail between and within the molecules of a body those active motions the energy of

which we call heat, there the material in which these movements can take place is compressible; in the sense that if already compressed it will yield to any extra pressure great or small tending to further reduce its bulk. We also seem to know with *certainty* (as I think, and notwithstanding what Dr. Chree has urged) that it is elastic also, that is that if relieved of a part of the pressure it will recover its pristine volume, provided that the temperature is kept from changing; and when Dr. Chree speaks of great pressure as "killing the elasticity" he has perhaps not taken into account the necessary dynamical consequence, which is that the density would in that case increase without limit as time goes on.

5. In paragraph (3) we had occasion to speak of the *so-called* solid part of the earth. This is because the earth is far from being solid in the sense attributed to that term in physical laboratories or by the mathematicians to whose investigations respecting elasticity Dr. Chree refers. If we desire to represent the earth on a small scale and within the brief duration of a laboratory experiment, it will in the first place be necessary to substitute for a solid material something very much more plastic; nor will it be easy to find a material which will represent, within the brief duration of human experiments, the kind of plasticity by means of which nature slowly carries on her work during the lapse of geological ages—a plasticity which causes the several parts of the earth to yield to pressures however feeble when time enough is allowed, but where they yield so imperceptibly, even under great pressures, that a sustained* force is at any one time transmitted across any part of the earth with almost the definiteness as regards its direction with which it would be transmitted by a theoretically rigid body. Accordingly when the earth is described as being plastic, what is to be understood is that the materials of which it is made up yield to *any* stresses tending to change their form, *if these stresses continue in action for sufficiently long periods of time*. The yielding seems mainly to consist in slips, which sometimes take place abruptly and on a molar scale by the small starts which occur when there are earthquakes or during volcanic eruptions; but usually they are molecular readjustments, acting without breach of continuity, and very slowly, both on a large and on a small scale. Some of the results on a small scale are familiar to us as foldings in strata and such like

* By a sustained force is meant one so gradually applied and so long maintained that it does not produce appreciable waves within the earth.

phenomena ; which are most conspicuous in the older formations where the stresses that produced them may have been in operation for enormous periods of time. I have seen a slab of white marble which formed the lintel of a very old chimney-piece that had so far yielded in less than a single century to the small stress produced by its own weight, aided by the alternate heatings and coolings to which it had been subjected, that it had become bent until it was lower *by almost an inch* in the middle than at the ends. The length of the slab, so far as I can recollect, was about four feet, its width about five inches, and its thickness about $\frac{3}{4}$ of an inch. There does not seem to be any solid material known to us in which there is not some plasticity of this kind—if bent, the molecular and intra-molecular motions that are ever going on accommodate themselves in some few instances to the new state of things ; and though the cases in which this happens may be very few compared with the whole number of molecular motions going on, every such accommodation when once effected is a step towards the body's assuming, in the long run, its new strained form. In a body like white marble, which is a congeries of small crystals, this accommodation may perhaps take place with most facility as molecular slips parallel to the planes of cleavage or along the junctions between crystals. In non-crystalline rocks, which are a more irregular jumble of materials, the new adjustment probably occurs with more facility in the positions of partial discontinuity ; while in slaty rocks it seems to have operated chiefly along the planes of cleavage, as well as (on a molar scale, as in all stratified rocks) throughout the looser material which is interposed between the strata. The slips which bring about the adjustment assume their largest proportions when they take the form of geological "faults," the production of each of which is accompanied by an earthquake.

6. Whether we are right in supposing that the adjustments operate with most effect in the situations indicated above, what is *certain* is that plasticity has brought about, after the lapse of geological ages, changes of form in the parts of the solid earth exposed to our view, which are accompanied by bendings vastly more curved than those required for the movements on a great scale which are everywhere going on within the earth ; which force us to recognize that the earth though elastic (*i. e.* resilient) as regards its volume is not quite elastic as regards its form. That this is the case seems *certain*.

7. If I understand Dr. Chree aright, he regards as incredible any hypothesis which would imply that the earth, owing to its elasticity, would expand from its present size, which is a globe

about 8000 miles across, to one of 12,000 miles in diameter, if the mutual gravitation of its parts were to cease, and if (which is a further necessary condition) that great amount of energy were imparted to it which would enable its several portions while expanding to retain the same temperatures which they have in their present compressed condition. Now, it is *certain* that under the circumstances supposed the earth would expand; and I see nothing antecedently improbable in the expansion having the amount which Dr. Chree thinks incredible, or one larger than it, or smaller. It is to be observed, however, that no authority attaches to the amount of expansion arrived at by Dr. Chree's mode of applying my provisional hypothesis, since he has taken no account of the fact that coefficients of expansion are functions of both t and p , as is shown above in paragraph 2, and that accordingly, if the temperatures are kept constant, the average value of these coefficients within the earth will vary with the pressures, and therefore change as the expansion goes on.

8. Dr. Chree's comments have left me under the impression that he conceives that I infer what has occurred geologically from a value of the average elasticity assumed beforehand; whereas the process I have attempted to follow is the converse of this. I infer the average coefficient of compressibility *from the observed facts of geology*; and I endeavour to show in my paper that the value so inferred, or something near it, must be the true value of this constant, if the compressions and expansions undergone by portions of the earth when loaded or relieved from load have been a machinery by the instrumentality of which nature has for ages been engaged in slowly augmenting the inequalities of the earth's surface.

9. It is from a consideration of the facts of geology, and especially of those under the ocean, that we can deduce the most *definite* estimate of what the average coefficient of compressibility of the earth must be to produce the observed effects. A careful study I gave to this subject many years ago led me to form the opinion that all the geological data I could then collect—terrestrial and oceanic—point to the conclusion that if a layer of material of twice the density of water were uniformly spread over any large portion of the land-surface of the earth, the new surface would (after the lapse of a sufficient time, and unless counteracting agencies are in operation) be nearly at the same level as the old. And, further, that the condensations and other movements within the earth, to which the slow imposition of this deposit would give rise, are of a *sufficiently* reversible character to enable the surface to resume nearly its original position if the deposit

were gradually removed. It follows from this, that a heavier deposit would cause the new surface to be lower than the old had been, and that by the imposition of a deposit of less specific gravity the surface would be raised. The reverse of these effects would take place on the removal of a superficial layer. The observations seemed also to show that the size of the loaded area, provided it exceeds a certain limit of size, makes little difference in the effect. From this we may infer that the plasticity of the earth acts in such a manner that the loading of a large area produces for a limited time (which, however, is probably many millions of years) nearly the same compression of the portion of the earth between it and the centre, as an equal loading of the whole surface of the earth would produce upon the whole volume of the earth. If we may assume this, we find that the earth's average coefficient of compressibility has the value I assigned to it, viz. about the same as the coefficient of compressibility of glass.

10. It is, however, of no particular importance whether this estimate is correct. What is of importance and at the same time *certain* is that the compressibility of the materials of which the earth consists and their plasticity operate in such-wise that a uniform pressure, great or small, over a *large* part of the surface (if applied so gradually as to avoid generating earth-waves, and also so as to give time for the plasticity to act) will inevitably cause *the surface to which the pressure is applied* to descend, except in those situations at which other counteracting movements are going on. And, contrariwise, a relief of pressure over a large part of the earth will of necessity cause *the surface from which the pressure is taken off*, to rise, unless prevented by interfering agencies. These qualitative results are *certain*.

11. As to what their quantitative value is, this must be ascertained by observation of the apparent elevations and depressions, since we do not possess the means of fixing *a priori* either the average coefficient of compressibility or the degree and kind of the earth's complex plasticity. As already stated, a comprehensive survey of the geological evidence seemed to show that the compressibility and the plasticity are such that the limiting specific gravity of matter which leaves the level unchanged when it is deposited on or removed from the land-surface of the earth, is nearly 2, probably a little less than 2. In other words, either the spreading of a layer of lighter material over a sufficiently wide expanse of the earth's land-surface, or the removal of a layer of heavier material, will bring the new surface to a higher level than the old; provided always that other agencies, such as deep-seated

movements within the earth, do not interfere. In the case of submarine deposits they must, being buoyed up by the water, have a specific gravity either approaching or exceeding 3, to be competent to occasion a deepening of the ocean. If the deposit has less specific gravity it tends to make the ocean shallower. The general result is that denudation *everywhere* tends to make the land part of the surface of the earth to rise, inasmuch as denudation always removes matter with a specific gravity greater than 2; whereas under water some of the deposits tend to make the ocean deeper and others tend to make it shallower.

12. Some of the events to be accounted for are the following:—The surface of the solid earth partly projects above the ocean in the form of continents and is partly submerged. Denudation *has been going on for ages over those parts that project*; while deposition of heavy materials (see ‘Challenger’ Report) has with equal persistency been going on *over precisely those portions of the floor of the ocean which are in the present day the most submerged*. Not only so, but denudation has, as a rule, *been going on for ages more rapidly over the parts which are now the most elevated above the sea, and less rapidly over the parts which are less elevated*. What I desire to insist on, and what I think has been proved and is *certain*, is that *it is physically possible* that what were originally less elevations and depressions *may* have been intensified as time went on, by the denudations and depositions which have invariably accompanied them; and I venture to express the *opinion* that it is largely through this agency (in fact everywhere except where it has been counteracted by other factors) that the elevations and depressions which we now find upon the earth, have attained their present magnitude. If Dr. Chree will weigh the fact that this is physically possible, he will hardly I think continue to maintain the paradox that the elevations and depressions have become what they now are, not in consequence of the agencies we find persistently in operation, but in spite of them.

13. In his first paragraph, p. 494, Dr. Chree describes it as “legitimate to hold that the deep-seated material has had its elasticity, so to speak, ‘killed’ under the enormous pressure to which it is exposed”; and in his third paragraph he gives as his opinion that the *only* satisfactory alternative “is to treat the earth as incompressible, or very nearly incompressible, throughout all but the surface strata.” Of these alternatives I have endeavoured to show in paragraph 4 of the present paper, that the former is physically impossible, and in paragraphs 3 and 4 that there is no presumption in favour of the second alternative.

14. Finally, Dr. Chree thinks that the result arrived at by calculating the amount of strain produced by applying a normal force at one point of a plane bounding a theoretically infinite elastic solid, devoid of plasticity and without weight, would give "a much better idea" than my method "of the order of magnitude of the elastic effects due to denudation and deposition" in the cases where the loaded area is limited to some few thousands of square miles [say where it is an area from 30 to 100 miles across]. Before this view can be admitted, Dr. Chree will have to show that a force applied at a *point* of the supposed surface would produce anything like the same dynamical effect as a pressure applied over an area so extensive that it behaves dynamically somewhat like the upper surface of a girder from 30 to 100 miles in length. He will also have to find some mass of non-volcanic mountains of this extent, which stand upon materials devoid of the plasticity, and not accompanied by the geological "faults," which tend to isolate such mountain ranges and their "Hinterland" from the neighbouring parts of the earth. My own observations lead me to suppose that no such case can be found.

15. On the whole, it does not appear to me that Dr. Chree's criticisms have shaken any of the positions that I ventured to put forward.

16. To put the whole matter briefly :—What I submit as the outcome of a careful inquiry may be summarized as follows—Whenever through the operation of any cause one of the existing continents emerged however little above the waters, denudation at once began to operate everywhere over it, and *has ever since persisted* in producing upon it whatever is the natural effect of denudation. So far is *certain*. It is also *certain* that the removal from any large continental area of a layer of such materials as exist at the surface of the earth will either (1) raise the new surface above the old surface or (2) will depress it*. *A priori* reasoning does not indicate which of these opposite effects should follow from the removal of the load, viz., a stratum having a specific gravity between 2·25 and 3 ; because the issue depends not only on the known factors (the thickness of the stratum and its weight), but also on the compressibility and other physical properties of the

* The fact that in a mountainous country denudation scoops out valleys may suggest to the superficial observer that the essential effect of denudation is to lower the surface. It is, however, *certain* that the mountain-range, as a whole, will press less on the material beneath it in consequence of the denudation which has scooped out its valleys ; that this underlying material down to unknown depths will in consequence expand ; and that this expansion must somewhat raise the whole mountain-range.

underlying portions of the earth, which we do not know *a priori*. Accordingly to determine which of the opposite effects has been the real one, we must have recourse to geological evidence. And what geology teaches us is:—(1) That the effect produced by denudation, whether it has been to raise the surface or to depress it, has been accumulating—all in one direction—for the immense geological age which has elapsed since the existing river-systems of the earth were established. And (2) that this accumulated movement whether it has been an upward movement or a downward has affected different parts of the continents upon the earth in different degrees: it has been exerted most efficiently upon those parts which we find to be now the highest; it has operated most feebly upon those which now lie the lowest; and it has affected in various degrees the other parts that stand at intermediate elevations—but always in degrees proportioned to the elevations at which we now find them.

17. From this geological evidence (especially when extended to the geology of the ocean, and pursued into details), we seem to me to be justified in drawing the inference that it is more likely—*much* more likely—that of the two physically possible effects of denudation, the raising or the lowering of the surface, the former is that which has actually been produced on the earth by this agent, and that the elevations have reached their present magnitude with the help of, not in opposition to, denudation. And the conclusion to which the geological evidence points so emphatically, is supported by our finding that it leads to values for the compressibility of the earth and for its plasticity which fall well within the limits of physical probability.

LIII. *The Quantity of Oxygen in the Atmosphere, compared with that in the Earth's Crust.* By GERALD STONEY, B.A., B.E., A.M.I.C.E.*

THE atmosphere consists of about 22·7 per cent. oxygen, 76 per cent. of nitrogen and argon, and 1·3 per cent. of aqueous vapour and minor constituents; and since its mean pressure is about 1033 grammes per square centimetre, it follows that there are 234·5 grammes of oxygen over every sq. centim. of the earth's surface.

Water contains eight parts of oxygen to one of hydrogen, and therefore 264 grammes of water contain 234·5 gr. of oxygen.

From this it follows that a stratum of water which is

* Communicated by Dr. G. Johnstone Stoney, F.R.S.

264 centim. (or 8 feet 8 inches) deep, contains as much oxygen as the superincumbent part of the atmosphere.

Similarly, since rocks, clay, &c. of which the land is composed are at least 40 per cent. oxygen, and have an average density of at least $2\frac{1}{4}$, the same depth of the land will contain as much, if not more, oxygen.

Thus it appears that a stratum less than 9 feet in depth of the surface of the earth, contains as much oxygen as the whole of the atmosphere. This shows that the quantity of free oxygen on the earth is exceedingly small in comparison with the quantity in combination, and that a very small quantity more in the crust of the earth would have left us with an atmosphere devoid of oxygen.

If we may assume the thickness of the earth's crust to be not less than 17 miles, and that it consists throughout of rocks similar to those exposed at the surface, it will follow that the quantity of oxygen in the atmosphere is less than a ten-thousandth part of that in the crust.

LIV. *On the Calculation of the Frequency of Vibration of a System in its Gravest Mode, with an example from Hydrodynamics.* By LORD RAYLEIGH, F.R.S.*

WHEN the expressions for the kinetic (T) and potential (V) energy of a system moving about a configuration of stable equilibrium are given, the possible frequencies of vibration are determined by an algebraic equation of degree (in the square of the frequency) equal to the number of independent motions of which the system is capable. Thus in the case of a system whose position is defined by *two* coordinates q_1 and q_2 , we have

$$\left. \begin{aligned} T &= \frac{1}{2}L\dot{q}_1^2 + M\dot{q}_1\dot{q}_2 + \frac{1}{2}N\dot{q}_2^2, \\ V &= \frac{1}{2}Aq_1^2 + Bq_1q_2 + \frac{1}{2}Cq_2^2; \end{aligned} \right\} \dots \quad (1)$$

and if in a free vibration the coordinates are proportional to $\cos pt$, the determinantal equation is

$$\begin{vmatrix} A-p^2L & B-p^2M \\ B-p^2M & C-p^2N \end{vmatrix} = 0, \dots \quad (2)$$

viz. :

$$p^4(LN - M^2) + p^2(2MB - LC - NA) + AC - B^2 = 0. \quad (3)$$

And whatever be the number of coordinates, the possible frequencies are given by a determinantal equation analogous to (2).

* Communicated by the Author.

When the determinantal equation is fully expressed, the smallest root, or indeed any other root, can be found by the ordinary processes of successive approximation. In many of the most interesting cases, however, the number of coordinates is infinite, and the inclusion of even a moderate number of them in the expressions for T and V would lead to laborious calculations. We may then avail ourselves of the following method of approximating to the value of the smallest root.

The method is founded upon the principle* that the introduction of a constraint can never lower, and must in general raise, the frequency of any mode of a vibrating system. The first constraint that we impose is the evanescence of one coordinate, say the last. The lowest frequency of the system thus constrained is higher than the lowest frequency of the unconstrained system. Next impose as an *additional* constraint the evanescence of the last coordinate but one. The lowest frequency is again raised. If we continue this process until only one coordinate is left free to vary, we obtain a series of continually increasing quantities as the lowest frequencies of the various systems. Or if we contemplate the operations in the reverse order, we obtain a series of decreasing quantities ending in the precise quantity sought. The first of the series, resulting from the sole variation of the first coordinate, is given by an equation of the first degree, viz. $A - p^2L = 0$. The second is the lower root of the determinant (2) of the second order. The third is the lowest root of a determinant of the third order formed by the addition of one row and one column to (2), and so on. This series of quantities may accordingly be regarded as successive approximations to the value required. Each is nearer than its predecessor to the truth, and all (except of course the last itself) are too high.

The practical success of the method must depend upon the choice of coordinates and of the order in which they are employed. The object is so to arrange matters that the variation of the first two or three coordinates shall allow a good approximation to the actual mode of vibration.

The example by which I propose to illustrate the method is one already considered by Prof. Lamb. It is that of the transverse vibration of a liquid mass contained in a horizontal cylindrical vessel, and of such quantity that the free surface contains the axis of the cylinder ($r=0$). If we measure θ vertically downwards, the fluid is limited by $r=0$, $r=c$, and

* 'Theory of Sound,' §§ 88, 89.

by $\theta = -\frac{1}{2}\pi$, $\theta = +\frac{1}{2}\pi$. Between the above limits of θ and when $r=c$ the motion must be exclusively tangential.

In the gravest mode of vibration the fluid swings from one side to the other in such a manner that the horizontal motions are equal and the vertical motions opposite at any two points which are images of one another in the line $\theta=0$. This relation, which holds also at the two halves of the free surface, implies a stream-function ψ which is symmetrical with respect to $\theta=0$.

Let η , denoting the elevation of the surface at a distance r from the centre on the side for which $\theta=\frac{1}{2}\pi$, be expressed by

$$\eta = -2q_2(r/c) + 4q_4(r/c)^3 - 6q_6(r/c)^5 + \dots ; \quad (4)$$

then the potential energy for the whole mass (supposed to be of unit density) is given by

$$V = 2 \int_0^c \frac{1}{2} g \eta^2 dr = 4gc \left(\frac{1}{3} q_2^2 - \frac{4}{5} q_2 q_4 + \frac{4}{7} q_4^2 + \dots \right). \quad (5)$$

The more difficult part of the problem lies in determining the motion and in the calculation of the kinetic energy. It may be solved by the method of Sir G. Stokes, who treated a particular case, corresponding in fact to our first approximation in which (4) reduces to its first term. It is required to find the motion of an incompressible fluid in two dimensions within the semicylinder, the normal velocity being zero over the whole of the curved boundary ($r=c$, $\frac{1}{2}\pi > \theta > -\frac{1}{2}\pi$) and over the flat boundary having values prescribed by (4). If ψ be the stream-function, satisfying $d^2\psi/dx^2 + d^2\psi/dy^2 = 0$, the conditions are that ψ shall be symmetrical with respect to $\theta=0$, that it be constant when $r=c$ from $\theta=0$ to $\theta=\frac{1}{2}\pi$, and that when $\theta=\frac{1}{2}\pi$,

$$d\psi/dr = d\eta/dt = -2\dot{q}_2(r/c) + 4\dot{q}_4(r/c)^3 - \dots,$$

$$\text{or} \quad \psi/c = -\dot{q}_2(r/c)^2 + \dot{q}_4(r/c)^4 - \dot{q}_6(r/c)^6 + \dots \quad (6)$$

At the edge, where $r=c$,

$$\psi/c = -\dot{q}_2 + \dot{q}_4 - \dot{q}_6 - \dots, \quad (7)$$

and this value must obtain also over the curved boundary.

The conditions may be satisfied* by assuming

$$\begin{aligned} \psi/c &= \dot{q}_2(r/c)^2 \cos 2\theta + \dot{q}_4(r/c)^4 \cos 4\theta + \dots \\ &+ \sum A_{2n+1}(r/c)^{2n+1} \cos (2n+1)\theta, \quad (8) \end{aligned}$$

* Lamb's 'Hydrodynamics,' § 72.

in which $n=0, 1, 2, \&c.$ This form satisfies Laplace's equation and the condition of symmetry since cosines of θ alone occur. When $\theta=\frac{1}{2}\pi$, it reduces to (6). It remains only to secure the reduction to (7) when $r=c$, and this can be effected by Fourier's methods. It is required that from $\theta=0$ to $\theta=\frac{1}{2}\pi$

$$\sum A_{2n+1} \cos (2n+1)\theta = -\dot{q}_2(1 + \cos 2\theta) + \dot{q}_4(1 - \cos 4\theta) - \dots \quad (9)$$

It will be convenient to write

$$A_{2n+1} = \dot{q}_2 A_{2n+1}^{(2)} + \dot{q}_4 A_{2n+1}^{(4)} + \dots, \quad (10)$$

so that

$$\sum A_{2n+1}^{(2s)} \cos (2n+1)\theta = (-1)^s - \cos 2s\theta. \quad (11)$$

In (11) s may have the values 1, 2, 3, &c.

The values of the constants in (11) are to be found as usual. Since

$$2 \int_0^{\frac{1}{2}\pi} \cos (2n+1)\theta \cdot \cos (2m+1)\theta d\theta$$

vanishes when m and n are different, and when m and n coincide has the value $\frac{1}{2}\pi$, and since

$$\begin{aligned} & 2 \int_0^{\frac{1}{2}\pi} \{(-1)^s - \cos 2s\theta\} \cos (2n+1)\theta d\theta \\ &= (-1)^{s+n} \left\{ -\frac{1}{2n+2s+1} + \frac{2}{2n+1} - \frac{1}{2n-2s+1} \right\}, \end{aligned}$$

we get

$$A_{2n+1}^{(2s)} = (-1)^{s+n} \frac{2}{\pi} \left\{ -\frac{1}{2n+2s+1} + \frac{2}{2n+1} - \frac{1}{2n-2s+1} \right\}, \quad (12)$$

in which $s=1, 2, 3, \&c., n=0, 1, 2, \&c.$

The value of ψ in (8) is now completely determined when $\dot{q}_2, \&c.$ are known. The velocity-potential ϕ is deducible by merely writing sines, in place of cosines, of the multiples of θ .

We have now to calculate the kinetic energy T of the motion thus expressed, supposing for brevity that the density is unity. We have in general

$$2T = \int \phi \frac{d\phi}{dn} ds, \quad (13)$$

where dn is drawn normally outwards and the integration extends over the whole contour. In the present case, however, $d\phi/dn$ vanishes over the circular boundary, so that the

integration may be limited to the plane part. Of this the two halves contribute equally. Now when $\theta = \frac{1}{2}\pi$,

$$\phi/c = \sum (-1)^n A_{2n+1} (r/c)^{2n+1}, \dots \dots \dots (14)$$

$$d\phi/dn = d\phi/r d\theta = -2\dot{q}_2(r/c) + 4\dot{q}_4(r/c)^3 - \dots (15)$$

Thus

$$T = \sum (-1)^n c^2 A_{2n+1} \left\{ -\frac{2\dot{q}_2}{2n+3} + \frac{4\dot{q}_4}{2n+5} - \dots \right\}, \dots (16)$$

where A_{2n+1} is given by (10) and (12); it is of course a quadratic function of $\dot{q}_2, \dot{q}_4, \&c.$

The summation with respect to n is easily effected in particular cases by decomposition into partial fractions according to the general formula

$$\frac{1}{(2n+2s+1)(2n+2s'+1)} = \frac{1}{2(s-s')} \left\{ \frac{1}{2n+2s'+1} - \frac{1}{2n+2s+1} \right\} \dots \dots (17)$$

If $s' = -s$, we have

$$\begin{aligned} \sum \frac{1}{(2n+2s+1)(2n-2s+1)} &= \frac{1}{4s} \left(\frac{1}{2n-2s+1} - \frac{1}{2n+2s+1} \right) \\ &= \frac{1}{4s} \left\{ \left(-\frac{1}{2s-1} - \frac{1}{2s-3} - \dots - 1 + 1 + \frac{1}{3} + \dots + \frac{1}{2s-1} \right. \right. \\ &\quad \left. \left. + \frac{1}{2s+1} + \dots \right) - \left(\frac{1}{2s+1} + \frac{1}{2s+3} + \dots \right) \right\} = 0. \dots (18) \end{aligned}$$

If $s' = s$, (17) fails, but we have by a known formula

$$\sum \frac{1}{(2n+2s+1)^2} = \frac{\pi^2}{8} - 1 - \frac{1}{3^2} - \frac{1}{5^2} - \dots - \frac{1}{(2s-1)^2}, (19)$$

Thus for the term in \dot{q}_2^2 , we have in (16)

$$\frac{4c^2\dot{q}_2^2}{\pi} \sum \frac{1}{2n+3} \left\{ -\frac{1}{2n+3} + \frac{2}{2n+1} - \frac{1}{2n-1} \right\}, \dots (20)$$

in which by (18)

$$\sum (2n+3)^{-1}(2n-1)^{-1} = 0,$$

by (17)

$$\begin{aligned} \sum (2n+3)^{-1}(2n+1)^{-1} &= \frac{1}{2} \sum (2n+1)^{-1} - \frac{1}{2} \sum (2n+3)^{-1} \\ &= \frac{1}{2} \left(1 + \frac{1}{3^2} + \frac{1}{5^2} + \dots \right) - \frac{1}{2} \left(\frac{1}{3^2} + \frac{1}{5^2} + \dots \right) = \frac{1}{2}, \end{aligned}$$

and by (19)

$$\sum (2n+3)^{-2} = \frac{1}{8}\pi^2 - 1.$$

The complete term (20) in \dot{q}_2^2 is accordingly

$$\frac{4c^2\dot{q}_2^2}{\pi} \left(2 - \frac{1}{8}\pi^2 \right). \dots \dots \dots (21)$$

The first approximation to p^2 is therefore from (5), (21)

$$p^2 = \frac{\pi}{3(2 - \frac{1}{8}\pi^2)} \frac{g}{c}, \quad \dots \dots \dots (22)$$

or

$$p = 1.1690 (g/c)^{\frac{1}{2}}, \quad \dots \dots \dots (23)$$

which is Prof. Lamb's result*.

For the second approximation we require also the terms in (16) which involve \dot{q}_4^2 and $\dot{q}_2 \dot{q}_4$, and they are calculated as before. The term in \dot{q}_4^2 is

$$\frac{8c^2 \dot{q}_4^2}{\pi} \sum \frac{1}{2n+5} \left(-\frac{1}{2n+5} + \frac{2}{2n+1} - \frac{1}{2n-3} \right) = \frac{8c^2 \dot{q}_4^2}{\pi} \left(\frac{16}{9} - \frac{\pi^2}{8} \right). \dots \dots (24)$$

The term in $\dot{q}_2 \dot{q}_4$ is made up of two parts. Its complete value is

$$-\frac{64c^2}{9\pi} \dot{q}_2 \dot{q}_4. \quad \dots \dots \dots (25)$$

Thus

$$T = \frac{4c^2}{\pi} \left(2 - \frac{\pi^2}{8} \right) \dot{q}_2^2 - \frac{64c^2}{9\pi} \dot{q}_2 \dot{q}_4 + \frac{8c^2}{\pi} \left(\frac{16}{9} - \frac{\pi^2}{8} \right) \dot{q}_4^2 + \dots, \quad (26)$$

which with (5) gives materials for the second approximation. In proceeding to this we may drop the symbols c and g , which can at any moment be restored by consideration of dimensions. Also the factor 8 may be omitted from the expressions for T and V . On this understanding we have by comparison with (1),

$$A = \frac{1}{3}, \quad B = -\frac{2}{5}, \quad C = \frac{4}{7};$$

$$L = \frac{2}{\pi} - \frac{\pi}{8}, \quad M = -\frac{8}{9\pi}, \quad N = \frac{32}{9\pi} - \frac{\pi}{4},$$

or on introduction of the value of π ,

$$L = .2439204, \quad M = -.2829420, \quad N = .3463696.$$

The coefficients of the quadratic (3) are thence found to be

$$LN - M^2 = .00443040, \quad AC - B^2 = .0304762,$$

$$2MB - LC - NA = -.0284860;$$

whence on restoration of the factor $(g/c)^{\frac{1}{2}}$,

$$p_1 = 1.1644 (g/c)^{\frac{1}{2}}, \quad p_2 = 2.2525 (g/c)^{\frac{1}{2}}, \quad \dots \dots (27)$$

the first of which constitutes the *second* approximation to the value of p in $\cos pt$, corresponding to the gravest mode

* 'Hydrodynamics,' § 238.

of vibration. The small difference between (23) and (27) shows the success of the method and indicates that (27) is but very little in excess of the truth.

If the result were of special importance it would be quite practicable to take another step in the approximation, determining p^2 as the lowest root of a cubic equation.

A question naturally suggests itself as to the significance of the value of p_2 in (27). The general theory of constraints* shows that it may be regarded as a first, but probably a rather rough, approximation to the frequency of the second lowest mode of the complete system. Just as for the gravest mode of all, the second lowest roots of the series of determinants (of the 2nd, 3rd, and following orders) form successive approximations to the true value, each value being lower and truer than its predecessor. The second approximation would be the middle root of the cubic above mentioned. But for this purpose it is doubtful whether the method is practical.

LV. Notices respecting New Books.

An Introduction to the Mathematical Theory of Attraction. By F. A. TARLETON, *Sc.D.* (Longmans, 1899, pp. xiv + 290.)

DR. TARLETON remarks that it is a matter of much importance that the acquisition of a competent knowledge of the Theory of Attractions should be made as easy as possible.

His object in the present work is to assist in doing this, and so he writes for Students and not for Professors. Though there is much of new presentment of the details of the work, he naturally, nay necessarily, draws extensively upon previous authorities, more especially upon Maxwell's 'Electricity and Magnetism,' Thomson and Tait's 'Natural Philosophy,' and Dr. Routh's recent treatise on the subject in vol. ii. of his 'Analytical Statics.' The main problems are, as he points out, to find the resultant force between two bodies, and to determine the distributions of electricity and magnetism which take place under given conditions.

Prof. J. D. Forbes, in his Dissertation on Physical Science (*Encyc. Brit.* p. 989) describes the doctrine of Attractions as being a complex and difficult one even when the distribution of the attracting matter as well as the fundamental law of attraction is known. And our author points out that the recent progress of the sciences of Electricity and Magnetism has increased the direct value of the theory. He discusses the 'Resultant Force' at some length, and then considers 'Lines of Force': next he devotes nearly one third of his Treatise to the consideration of the Potential. This branch is very thoroughly treated. The remaining chapters are devoted to Sur-

* 'Theory of Sound,' 2nd ed. § 92 a.

faces and Curves of the second degree, Electric Images, and Systems of Conductors. In addition to the clear textual exposition of the matter, there is an extensive collection of examples, very many of which are worked out with full detail: these will be of great use to the student. There are several elegant and instructive proofs which have been furnished by Prof. F. Purser.

With a Table of Contents and an Index, this text-book, which is very accurately printed, is likely to be appreciated by junior students, while at the same time more advanced ones may consult it with advantage.

Théorie du Potentiel Newtonien. Leçons professées à la Sorbonne par H. POINCARÉ rédigées par ÉDOUARD LEROY et GEORGES VINCENT. Pp. 366. 8vo; Paris, 1899.

THIS book forms part of Poincaré's *Cours de Physique Mathématique*, and it may be said at once that it is the best of the series. The author is, as everyone knows, a master of mathematical analysis; he is besides the possessor of a most luminous style of exposition, and, as he is here occupied with a subject in which he has himself made important advances, great hopes must have been aroused among mathematicians interested in the Theory of the Potential by the announcement of the publication of these lectures. Such hopes will not be disappointed.

The theory under consideration is the most striking example of the assistance rendered to pure mathematics by applied mathematics. The importance of a thorough study of what we now call "potential functions" was seen by Laplace in his researches on gravitation, and especially on the figure of the earth; it was emphasised by Green in connexion with electrostatics and magnetism. Such a study has been found to be no less requisite as a preliminary to the mathematical theories of hydrodynamics and elasticity; in the formulation of each of these branches of applied mathematics it has been found that, if the theories are not to be self-contradictory, there ought to exist functions which satisfy Laplace's equation at all points in a particular region of space, and also satisfy certain conditions at the boundaries of the region. The determination of a function from such conditions becomes a problem of profound interest to mathematicians, and the principle of the existence of such functions led, in the hands of Riemann, to nothing less than a revolution in the theory of functions of a complex variable. In the time of Riemann the proof of this principle which had been given by Dirichlet was accepted as valid; but since the fallacy that underlies this proof has been exposed by Weierstrass, mathematicians have had to seek for proof in other directions. Thus has arisen the famous "existence-theorem," to the construction of the rigid proof of which the efforts of many analysts have been directed.

But if the existence-theorem is the roof and crown of the theory of the potential, it is by no means the only part of the theory

which has needed to be made rigorous by the touch of a master-hand well skilled in the refinements of modern mathematical analysis. That the strengthening of the base of the structure was a problem well worthy of the powers of a fully equipped analyst was realised by Picard, and the chapters of his *Traité d'Analyse* devoted to the exposition of the theory show the conspicuous success which attended his efforts. The author of the work before us has been no less successful in the independent treatment of fundamental questions, and his discussion of the convergence of the integrals which represent the components of attraction at or near a point on a charged surface will especially repay careful reading.

The author devotes the first three Chapters of his book to what would in this country be regarded as the elements of the theory, sparing no pains to establish them in a thoroughly rigorous fashion. In the fourth Chapter he introduces Green's function and explains its importance; and in the following chapter he utilises Green's function for a sphere and a point to construct a function satisfying Laplace's equation within a sphere and taking a given value at all points of the surface: this is Dirichlet's problem for a sphere. The sixth Chapter is devoted to the properties of magnetic shells or sheets of doublets. In the seventh Chapter the author presents his own proof of the existence-theorem: this proof is founded on a theory of the equivalence of certain surface and volume distributions; it is shown that the equivalent distributions can be determined for a sphere, and that for any surface without conical points the solution of Dirichlet's problem can be arrived at by constructing such distributions and the related potential functions for a definite series of spheres. As is well known, the author has extended this proof to a more general class of surfaces, and the construction of it must be regarded as one of his most brilliant achievements in analysis; in his book he wisely refrains from presenting the proof for the more complicated case, and refers the reader to his memoir in the 'American Journal of Mathematics,' vol. xii. The eighth Chapter contains an account of the method by which Neumann sought to construct the solution of Dirichlet's problem for a surface by means of a sheet of doublets, or a magnetic shell, coinciding with the surface; and the ninth and last Chapter contains indications concerning a number of extensions of Neumann's method. The account of the method is most lucid and suggestive, and, as the author points out, the method is of especial importance on account of the identity which it establishes between the functions which satisfy Laplace's equation in limited regions of space and the potentials of distributions of density.

British readers will not fail to notice the use that is made, throughout the last six Chapters, of Gauss's theorem that the mean value of a potential function over the surface of a sphere is the same as the value at the centre; in English books on the same subject this theorem appears as a curious incidental result. It

will also be observed that the book as a whole presents an orderly development of a single beautiful theory with few divergences into by-paths, though with some indications of possible extensions. In particular the two-dimensional or logarithmic potential is not exhaustively treated in the same manner as the ordinary potential, although the importance of the results obtained in respect of the general theory of functions is pointed out. The extension to space of more than three dimensions is not treated in any detail.

It is very unfortunate that a book otherwise so excellent should be carelessly printed, some of the misprints are of a most irritating character.

A. E. H. L.

A History of Physics in its Elementary Branches, including the Evolution of Physical Laboratories. By FLORIAN CAJORI, Ph.D.
New York: The Macmillan Company, 1899.

THIS is in many respects a disappointing book. The author has endeavoured to write a history of experimental method in the various branches of physics, rather than a historical survey of the development of physical thought and ideas. The result is that a large portion of the volume is made up of material gathered from the ordinary text-books and somewhat amplified, to which short biographies of the various physicists mentioned have been added. As a concise collection of facts, most of which are well known to the majority of teachers of physics, although gathered from various sources, it may serve a useful purpose in directing a student's reading; but it can scarcely be regarded as an important contribution to the history of physics.

J. L. H.

LVI. *Proceedings of Learned Societies.*

GEOLOGICAL SOCIETY.

[Continued from p. 499.]

January 18th, 1899.—W. Whitaker, B.A., F.R.S., President,
in the Chair.

THE following communications were read:—

1. 'On a small Section of Felsitic Lavas and Tuffs near Conway (North Wales).' By Frank Rutley, Esq., F.G.S.

The rocks described in this communication were collected in 1877, in series, at short intervals, from a point at the mouth of the River Conway near Bodlondeb. They consist of felsitic lavas and tuffs, sometimes nodular, and generally exhibiting some variety of fluxion-structure, corrugated, or banded. A specimen showing brown bands is compared with one described by Iddings from the Yellowstone Park. What were once possibly red bands are now represented by devitrified brown glass, and the change in colour may have been due to the action of water upon the ferric oxide which originally gave its colour to the glass. Some of the rhyolites are tufaceous, and envelop fragments of rocks, some of which were originally vitreous, others lithoidal. Coarser rhyolitic tuff occurs at the northern end of the series.

2. 'The Geology of Southern Morocco and the Atlas Mountains.'
By the late Joseph Thomson, Esq.

This paper gives the results of observations made under considerable difficulties during a journey in Morocco in 1888. The tract traversed is roughly triangular, the base being the Atlantic Ocean between Saffi and Agadir, and the apex the district of Demnat on the northern slopes of the Atlas, some 60 miles east of the city of Morocco. This district consists of three main sections:—(1) The Coast Lowlands; (2) the Plateau in two chief steps, the northern rising to 2000 and the southern to 5000 feet; (3) the Atlas itself, which only begins to be a mountain-chain about 30 miles from the coast, and which ranges first east-by-north and then north-east in its central and loftiest part.

(1) The Lowlands are practically conterminous with the Tertiary deposits, among which apparently Eocene, Miocene, and Pliocene rocks are represented. The latter consist of shelly sands 200 to 300 feet thick, gradually rising to a height of 700 feet south and east of Saffi. Their surface is often covered with the slaggy tufaceous crust described by Maw. The local presence of this crust and the porous character of the deposit elsewhere have preserved it from denudation, and thus (in the opinion of the author) its surface still presents the appearance of the Tertiary sea-bed on which it was formed. Certain quarry-like pits, one of which contains a pillar of white crystalline calcium carbonate, are supposed to be due to the explosion of steam connected with the existence of hot springs.

(2) The Plateau is underlain by three rock-formations:—
(a) Metamorphic rocks including clay-slates, which probably underlie the whole Plain of Morocco and rise into a group of rugged hills called the 'Jebelet,' in contradistinction to the 'Jebel' or Atlas proper. (b) The Lower Cretaceous rocks, consisting of red shales and sandstones, the former frequently giving rise to brine springs and containing salt-deposits at Demnat in the Atlas. (c) The Upper Cretaceous rocks, chiefly white and cream-coloured limestones, which attain their greatest development on the Plateau.

(3) The Atlas itself is made up for the most part of the same rocks. There is a core of metamorphic rocks, which is better developed and wider at the western end of the range and narrower towards the east. Next comes the great development of the Lower Cretaceous strata, followed by a diminutive representative of the Upper Cretaceous rocks. These rocks are much broken by folding and faulting, and their structure is displayed in several sections taken across the range from Demnat westward. The first signs of glacial action were met with at Titula, consisting of moraine-like heaps of débris; elsewhere, scratched stones were found. The Boulder-deposits described by Maw were not seen either east or west of the locality described by that author; but Maw's original section was not traversed, and the present author does not offer any opinion as to the origin of the beds. Intrusive basalts penetrate the Cretaceous rocks, while porphyrites, diorites, and other igneous rocks pierce the metamorphic rocks of the central core.

INDEX TO VOL. XLVII.

- ÆTHER**, on the relative motion of the earth and, 252.
- Air**, on the cooling of, by radiation and conduction, 308; on the conduction of heat in a spherical mass of, confined by walls at a constant temperature, 314.
- Ampère**, on an experiment of, 331.
- Arnold-Bemrose (H. H.)** on the geology of the Ashburne and Buxton branch of the L. & N.W. Ry., 498.
- Atmosphere**, on the transmission of light through an, containing small particles in suspension, 375.
- Barton (Dr. E. H.)** on the equivalent resistance and inductance of a wire to an oscillatory discharge, 433.
- Barus (Dr. C.)** on the absorption of water in hot glass, 104, 461.
- Bernouilli's theorem** in probabilities, on, 246.
- Black spot in liquid films**, on the thickness of the, 501.
- Books, new**:—Routh's Treatise on Dynamics of a Particle, 163; Fisher and Schwatt's Textbook of Algebra, 251; Murray's Elementary Course in the Integral Calculus, 325; Harper's Scientific Memoirs, I. The Free Expansion of Gases, II. Prismatic and Diffraction Spectra, 417; Holman's Matter, Energy, Force, and Work, 496; Harkness and Morley's Introduction to the Theory of Analytic Functions, 497; Tarleton's Introduction to the Mathematical Theory of Attraction, 572; Poincaré's Théorie du Potentiel Newtonien, 573; Cajori's History of Physics, 575.
- Brush discharge**, experiments with the, 40, 331.
- Callendar (Prof. H. L.)** on platinum thermometry, 191.
- Campbell (A.)** on the magnetic fluxes in meters and other electrical instruments, 1.
- Cathode rays**, on the, 269, 415.
- Chabot (J. J. T.)** on the combination of an experiment of Ampère with one of Faraday, 331.
- Chance**, on the hypergeometrical series and the theory of, 236.
- Chapman (D. L.)** on the rate of explosion in gases, 90.
- Chree (Dr. C.)** on longitudinal vibrations in solid and hollow cylinders, 333; on denudation and deposition, 494.
- Colour-photography**, application of the diffraction-grating to, 368.
- Condensers**, on the measurement of the energy dissipated in, 19, 222.
- Conduction**, on the cooling of air by, 308; of heat in a spherical mass of air confined by walls at a constant temperature, on the, 314.
- Convection**, on the source of energy in diffusive, 522.
- Cook (Dr. E. H.)** on experiments with the brush discharge, 40.
- Cylinders**, on longitudinal vibrations in solid and hollow, 333.
- D₁ and D₂**, application of Sellmeier's dynamical theory to the dark lines, 302.
- Denudation and deposition**, on, 372, 494, 557.
- Diffraction-fringes**, application of, to micrometric observations, 441.
- Diffraction-grating**, application of the, to colour-photography, 368.
- Diffusion**, on the source of energy in, 522; on an apparatus for the determination of the rate of, 530.
- Discharge**, on the equivalent resistance and inductance of a wire to an oscillatory, 433.
- Earth**, on the age of the, as an abode fitted for life, 66.

- Elastic solid, on the application of force required to produce spherical solitary waves or trains of periodic waves in an, 480.
- Electrical conduction produced by uranium radiation, on the, 109.
- conductivity and opacity, on the relation between, 385.
- instruments, on the magnetic fluxes in, 1.
- oscillations, on the propagation of damped, along parallel wires, 296.
- waves in sea-water, 413.
- Electricity, on the conduction of, through gases by charged ions, 253.
- Electrometer, on a five-celled quadrant, 499.
- Energy dissipated in condensers, on the measurement of, 19, 222.
- Explosion, on the rate of, in gases, 90.
- Faraday, on an experiment of, 331.
- Films, on the thickness of the black spot in liquid, 501.
- Filoni (L. N. G.) on certain diffraction-fringes as applied to microscopic observations, 441.
- Frequency of vibration of a system in its gravest mode, on the calculation of the, 566.
- Gases, on the rate of explosion in, 90; on the absorption of uranium radiation by, 123; on the conduction of electricity through, by charged ions, 253.
- Geological Society, proceedings of the, 326, 417, 498, 575.
- Glass, on the absorption of water in hot, 104, 461.
- Gold-leaf, on the opacity of, 385.
- Gordon (Mrs. M. M.) on the torsion structure of the dolomites, 419.
- Griffiths (A.) on the source of energy in diffusive convection, 522; on an apparatus for the determination of the rate of diffusion of solids dissolved in liquids, 530.
- Groom (Prof. T. T.) on the geological structure of the Southern Malvern, 327.
- Haga (Prof. H.) on a five-cell quadrant electrometer, 499.
- Harrison (Prof. J. B.) on the oceanic deposits of Trinidad, 498.
- Heat, on the conduction of, in a spherical mass of air confined by walls at a constant temperature, 314; on the, produced by moistening pulverized bodies, 329; on the effect of, on longitudinally magnetized iron wire, 421.
- Heaviside (O.) on electrical waves in sea-water, 413.
- Hypergeometrical series, on certain properties of the, 236.
- Inductance of a wire to an oscillatory discharge, on the, 433.
- Interference-method, on the application of an, to the investigation of Young's modulus for wires, 539.
- Ions, on the velocity of the, in uranium conduction, 145; on the conduction of electricity through gases by charged, 253.
- Iron wire, on the effects of temperature and of circular magnetization on longitudinally magnetized, 421; on the change in dimensions of, by magnetization, 539.
- Johannott (E. S., jun.) on the thickness of the black spot in liquid films, 501.
- Jukes-Browne (A. J.) on the oceanic deposits of Trinidad, 498.
- Kelvin (Lord) on the age of the earth as an abode fitted for life, 66; on the reflexion and refraction of solitary plane waves at a plane interface between two isotropic elastic mediums, 179; on the application of Sellmeier's dynamical theory to the dark lines D_1 , D_2 produced by sodium vapour, 302; on the application of force required to produce spherical solitary waves or trains of periodic waves in an elastic solid, 480.
- King (W. W.) on the Permian conglomerates of the Lower Severn basin, 417.
- Lebfeldt (Dr. R. A.) on the properties of liquid mixtures, 284.
- Lenard rays, on the, 269.
- Light, on the transmission of, through an atmosphere containing small particles in suspension, 375.
- Liquid films, on the thickness of the black spot in, 501.
- mixtures, on the properties of, 284.

- Liquids, on an apparatus for the determination of the rate of diffusion of solids dissolved in, 530.
- Lodge (Prof. O.) on opacity, 385.
- Longitudinal vibrations in solid and hollow cylinders, on, 333.
- Magnetic field, on radiation phenomena in the, 165.
- fluxes in meters and other electrical instruments, on the, 1.
- phenomena, on the analogy of some irregularities in the yearly range of meteorological and, 57.
- Magnetization, on the effect of circular, on longitudinally magnetized iron wire, 421; on the change in dimensions of iron and steel wires by, 539.
- Marchant (E. W.) on experiments with the brush-discharge, 331.
- Marr (J. E.) on a conglomerate near Melmerby, 326.
- Martini (Prof. T.) on the heat produced by moistening pulverized bodies, 329.
- Meteorological phenomena, on the analogy of some irregularities in the yearly range of magnetic and, 57.
- Meters, on the magnetic fluxes in, 1.
- Micrometric observations, on the application of certain diffraction-fringes to, 441.
- Mirages, experiments on artificial, 349.
- Morton (W. B.) on the propagation of damped electrical oscillations along parallel wires, 296.
- Ogilvie (Dr. M. M.) on the torsion-structure of the dolomites, 419.
- Opacity, on, 385.
- Oscillations, on the propagation of damped electrical, along parallel wires, 296.
- Oxygen, on the quantity of, in the atmosphere compared with that in the earth's crust, 565.
- Pearson (Prof. K.) on certain properties of the hypergeometrical series and on the fitting such series to observation polygons in the theory of chance, 236.
- Pentane, on the thermal properties of normal, 353.
- Photography, application of the diffraction-grating to colour-, 368.
- Pitcher (F. H.) on the effects of temperature and of circular magnetization on longitudinally magnetized iron wire, 421.
- Platinum thermometry, on, 191.
- Preston (Dr. T.) on radiation phenomena in the magnetic field, 165.
- Probabilities, on Bernoulli's theorem in, 246.
- Pulverized bodies, on the heat produced by moistening, 329.
- Radiation, on the cooling of air by, 303.
- Radiation phenomena in the magnetic field, on, 165.
- Rayleigh (Lord) on James Bernoulli's theorem in probabilities, 246; on the cooling of air by radiation and conduction, and on the propagation of sound, 303; on the conduction of heat in a spherical mass of air confined by walls at a constant temperature, 314; on the transmission of light through an atmosphere containing small particles in suspension, and on the origin of the blue of the sky, 375; on the frequency of vibration of a system in its gravest mode, 566.
- Resistance of a wire to an oscillatory discharge, on the, 433.
- Rijkevorsel (Dr. van) on the analogy of some irregularities in the yearly range of meteorological and magnetic phenomena, 57.
- Röntgen rays, on the, 269.
- Rosa (E. B.) on methods of measuring the energy dissipated in condensers, 19, 222.
- Rose-Innes (J.) on the thermal properties of normal pentane, 353.
- Rutherford (Prof. E.) on uranium radiation and the electrical conduction produced by it, 109.
- Rutley (F.) on felsitic lavas and tuffs near Conway, 575.
- Sea-water, on electrical waves in, 413.
- Sellmeier's dynamical theory, on the application of, to the dark lines D_1 , D_2 produced by sodium vapour, 302.
- Shakespear (G. A.) on the application of an interference-method to the investigation of Young's

- modulus for wires, and its relation to changes of temperature and magnetization, 539.
- Sky, on the origin of the blue of the, 375.
- Smith (A. W.) on methods of measuring the energy dissipated in condensers, 19, 222.
- Sodium vapour, application of Sellmeier's dynamical theorem to the dark lines D_1 , D_2 produced by, 302.
- Solids, on an apparatus for the determination of the rate of diffusion of, dissolved in liquids, 530.
- Solitary plane waves, on the reflexion and refraction of, 179.
- Sound, on the propagation of, 308.
- Spectral lines, magnetic perturbations of the, 165.
- Steel wire, on the changes in the dimensions of, by magnetization, 539.
- Stoney (G.) on the quantity of oxygen in the atmosphere compared with that in the earth's crust, 565.
- Stoney (Dr. G. J.) on denudation and deposition, 372, 557.
- Sutherland (W.) on the relative motion of the earth and æther, 252; on cathode, Lenard, and Röntgen rays, 269.
- Thermometry, on platinum, 191.
- Thompson (B.) on the geology of the Great Central Railway, 327.
- Thomson (J.) on the geology of Southern Morocco, 576.
- Thomson (Prof. J. J.) on the conduction of electricity through gases by charged ions, 253; on the cathode rays, 415.
- Thorium radiation, on, 122.
- Tornadoes, experiments on artificial, 349.
- Uranium radiation and the electrical conduction produced by it, on, 109.
- Vibration, on the frequency of, of a system in its gravest mode, 566.
- Vibrations, on longitudinal, in solid and hollow cylinders, 333.
- Water, on the absorption of, in hot glass, 104, 461.
- Waves, on the reflexion and refraction of solitary plane, 179; on electrical, in sea-water, 413; on the application of force required to produce spherical solitary, or trains of periodic, in an elastic solid, 480.
- Wills (A. P.) on the susceptibility of diamagnetic and weakly magnetic substances, 164.
- Wires, on the propagation of damped electrical oscillations along parallel, 296; on the equivalent resistance and inductance of, to an oscillatory discharge, 433; on the application of an interference-method to the investigation of Young's modulus for, and on the change in dimensions of iron and steel, by magnetization, 539.
- Wood (R. W.) on artificial mirages and tornadoes, 349; on an application of the diffraction-grating to colour-photography, 368.
- Young (Dr. S.) on the thermal properties of normal pentane, 353.
- Young's modulus for wires, on the application of an interference-method to the investigation of, 539.

END OF THE FORTY-SEVENTH VOLUME.





SMITHSONIAN INSTITUTION LIBRARIES



3 9088 01202 4618