

UNIVERSITY OF TORONTO



3 1761 01541702 5

# LUMBER

RALPH CLEMENT BRYANT







Digitized by the Internet Archive  
in 2007 with funding from  
Microsoft Corporation



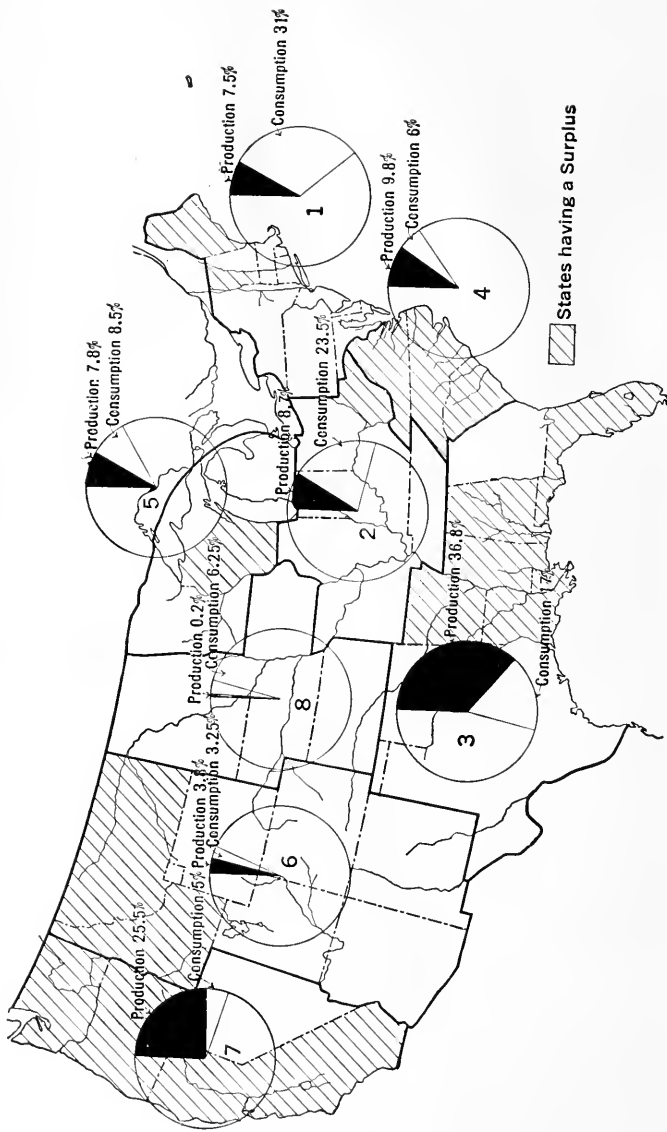

FIG. 1.—A Map of the United States showing the Seventeen States which, in 1920, produced more Lumber than they consumed; also the Per Cents of Total Production and Consumption for Eight Groups of States. 1. Northeastern Group. 2. Central Group. 3. Southern Group. 4. North Carolina Group. 5. Lake States Group. 6. Rocky Mountain Group. 7. Pacific Group. 8. All other States.

# LUMBER

ITS MANUFACTURE AND DISTRIBUTION

BY

RALPH CLEMENT BRYANT, F.E., M.A.

*Manufacturers' Association Professor of Lumbering  
Yale University*

NEW YORK

JOHN WILEY & SONS, Inc.

LONDON: CHAPMAN & HALL, LIMITED

1922



12600.

Copyright, 1922  
BY  
RALPH C. BRYANT

TS  
21  
17

PRESS OF  
BRAUNWORTH & CO.  
BOOK MANUFACTURERS  
BROOKLYN, N. Y.



TO  
A. J. B.  
WHO FOR MANY YEARS HAS BEEN  
AN UNFAILING SOURCE OF INSPIRATION  
THIS VOLUME IS DEDICATED  
WITH GRATITUDE  
AND AFFECTION



## PREFACE

---

THIS volume has been prepared as a forest-school text- and reference-book for instructors and students in lumbering.

The subject matter is grouped under three main headings which cover lumber manufacturing equipment, lumber manufacture, and markets and marketing. The great mass of available material has made it necessary to omit many details which, although of interest, are not essential to the text, which is based largely upon information collected by the author during the past sixteen years. However, many articles in lumber trade journals and other publications have been freely consulted and have proved a valuable aid. The illustrations of sawmill machinery and equipment were taken chiefly from the catalogues of machinery manufacturers or from photographs furnished by them.

The author wishes to acknowledge his indebtedness to all who have aided in any way in the preparation of this volume, especially to those lumber manufacturers who, by extending the courtesies of their plants to him, have made possible the collection of much of the data contained in this volume.

R. C. BRYANT.

NEW HAVEN, CONN.

July 1, 1922.



# CONTENTS

---

	PAGE
INTRODUCTION.....	xv

## PART I THE MANUFACTURING PLANT

### CHAPTER I CHARACTER, LOCATION AND ARRANGEMENT

Character.....	3
Plant Location.....	5
Character of Settlement.....	8
General Arrangement of Plant.....	9

### CHAPTER II LOG STORAGE

Land Storage.....	12
Rollway.....	12
Cableway System.....	13
Monorail.....	14
Other Devices.....	14
Water Storage.....	16
Storage Areas.....	16
Hot Pond.....	18
Pond Cleaning.....	19
Pond Crew.....	21

### CHAPTER III SAWMILL EQUIPMENT

The Building.....	22
Elevation of Logs into the Mill.....	24
From Land Storage.....	26
From Water Storage.....	30
Removal of Grit from Logs by Washing.....	35
Devices for Cross-cutting Logs.....	36
The Log Deck and Deck Machinery.....	42
The Log Carriage and its Accessories.....	52

## CHAPTER IV

SAWMILL EQUIPMENT (*Cont.*)

	PAGE
Head Saws . . . . .	77
Circular Mills . . . . .	78
Band Mills . . . . .	81
Re-sawing Mills . . . . .	89
Circular Gang Mill . . . . .	96
Rock Saw . . . . .	97
The Edger . . . . .	98
The Trimmer . . . . .	102
The Slasher . . . . .	107
Wood Refuse Grinders . . . . .	108
Refuse Burners . . . . .	109

## CHAPTER V

## SAWS

Saw Teeth . . . . .	114
Circular Saws . . . . .	115
Band Saws . . . . .	121
Reciprocating or Sash-gang Saws . . . . .	128

## CHAPTER VI

LUMBER HANDLING AND TRANSFER EQUIPMENT AND  
METHODS

Sawmill . . . . .	130
Green Lumber Assorting . . . . .	136
Timber Docks . . . . .	139
Lumber Transportation about the Plant . . . . .	140
Wheeled Vehicles . . . . .	140
Surface Carriers . . . . .	144
Monorail System . . . . .	145
Cranes . . . . .	148
Rollers and Chains . . . . .	152
Cableway System . . . . .	152
Lumber Sky-line . . . . .	153
Small Rail Cars . . . . .	154

## CHAPTER VII

## THE SAWMILL POWER PLANT

Small Mills . . . . .	157
The Building . . . . .	157
Power . . . . .	157
Large Mills . . . . .	159
The Building . . . . .	159
Motive Power . . . . .	159
Lighting System . . . . .	163
Steam-producing Equipment . . . . .	163

PART II  
LUMBER MANUFACTURE

CHAPTER VIII

LABOR

	PAGE
Character .....	171
Housing and Social Welfare .....	172
Wages and Efficiency .....	173
Sawmill Occupations .....	181
Manner of Employment .....	182
Unions .....	183
Accident Prevention .....	185
Workmen's Compensation Acts .....	186

CHAPTER IX

SAWING, EDGING, AND TRIMMING

Sawing .....	189
Plain-sawing .....	192
Quarter-sawing .....	195
Division of Time in Sawing .....	198
Sawyer's Signals .....	199
Edging .....	199
Trimming .....	200
Instructions to Sawyers .....	201

CHAPTER X

SEASONING LUMBER

Reasons for Seasoning .....	204
Air-seasoning .....	205
Yard Location .....	205
Runways .....	205
Pile Foundations .....	208
Piling Methods .....	209
Pile Roofs .....	213
Pole Stacking .....	214
Shed Seasoning .....	215
Shed Storage .....	216
Prevention of End Checking .....	216
Use of Salt in Seasoning Lumber .....	217
Time Required for Air-seasoning .....	218
Prevention of Sap Stain .....	219
Yard Sanitation .....	222

	PAGE
Dry Kiln Seasoning.....	225
Development.....	225
Classification of Dry Kilns.....	227
Progressive Type.....	228
Compartment Type.....	228
Dry-air Kilns.....	229
Moist-air Kilns.....	230
Super-heated Steam Kilns.....	234
Dry Kiln Equipment.....	235
Loading Kiln Trucks.....	240
Unloading Kiln Trucks.....	242
Capacity of Dry Kilns.....	243
Depreciation of Lumber during the Seasoning Process.....	244
Effect of Seasoning on Weight.....	247

## CHAPTER XI

### THE RE-MANUFACTURE OF LUMBER

Reasons for Re-manufacture.....	248
The Re-manufacturing Plant.....	249
The Building.....	249
The Equipment.....	251
Refuse Handling Equipment.....	257
The Power Equipment.....	263

## CHAPTER XII

### PRODUCTS OF THE LUMBER INDUSTRY

Sizes of the Sawed Products.....	267
Lumber Patterns.....	271
Grades Produced.....	272
Stocks.....	275

## CHAPTER XIII

### MILL REFUSE AND ITS DISPOSAL

Merchantable Volume of a Tree.....	279
Loss of Volume in Log Conversion.....	280
Bark.....	281
Sawdust.....	281
Slabs.....	282
Edging Strips.....	283
Trimmings.....	284
Shavings.....	284



	PAGE
Refuse Disposal.....	285
Fuel.....	285
Lath Manufacture.....	286
Shingles.....	288
"Shorts" and Box Stock.....	288
Pulp Stock.....	289
Other Uses.....	289
Burning in Open or Closed Burners.....	289

## CHAPTER XIV

## FIRE PREVENTION AND INSURANCE

Fire Causes.....	291
Fire Prevention.....	292
Fire Detection.....	293
Fire Control.....	294
Fire Insurance.....	299
Plant Appraisal.....	301
Lumber Values.....	301

## PART III

## LUMBER MARKETS AND MARKETING

## CHAPTER XV

## LUMBER TRADE ASSOCIATIONS

Manufacturers' Associations.....	305
Southern Yellow Pine.....	306
Northern Carolina Pine.....	307
Cypress.....	307
White Pine.....	308
West Coast.....	309
Hardwoods.....	309
Spruce.....	310
Inland Empire.....	311
Hemlock and Hardwoods.....	311
California Sugar and White Pine.....	311
Redwood.....	312
National Lumber Manufacturers' Association.....	312
Early Manufacturers' Association Activities.....	313
Recent Manufacturers' Association Activities.....	317
Retail Associations.....	318
Wholesale Associations.....	322
Legal Proceedings against the Lumber Industry.....	327
Santa Clara Valley Mill and Lumber Company.....	327
Mississippi Valley Lumbermen's Association.....	327
Northwestern Lumbermen's Association.....	327

	PAGE
Nebraska Lumber Dealers' Association.....	328
Retail Dealers' Association of Mississippi and Louisiana.....	329
Lumber Trust.....	329
Yellow Pine Manufacturers' Association.....	331
Toledo (Ohio) Retail Lumber Dealers.....	333
Eastern States Retail Lumber Dealers' Association.....	334
Lumber Secretaries' Bureau of Information.....	335
Northwestern Lumbermen's Association.....	336
Hardwood "Open Competition Plan".....	338
Southern Pine Association.....	341
West Coast Lumbermen's Association.....	342
Western Pine Manufacturers' Association.....	343

## CHAPTER XVI

## LUMBER GRADES AND INSPECTION

Formulation of Rules for the Grading and Inspection of Lumber.....	345
State Rules for Grading and Inspecting Lumber.....	348
Private and Association Rules for Grading and Inspecting Lumber.....	349
Southern Yellow Pine.....	350
Eastern White Pine.....	352
Western White Pine.....	353
Western Yellow Pine.....	353
Sugar Pine.....	354
Norway Pine.....	354
Lodgepole Pine.....	354
Douglas Fir.....	354
Hemlock.....	355
Spruce.....	356
Larch.....	357
Cypress.....	357
Redwood.....	358
Cedar.....	358
Hardwoods.....	358
Enforcement of Rules for the Grading and Inspection of Lumber.....	360

## CHAPTER XVII

## TRANSPORTATION

Rail Transportation.....	363
Tonnage.....	363
Car Stakes.....	364
Car Capacity.....	365
Car Weighing Service.....	366
Freight Rates.....	367
Classification.....	369
Milling-in-transit.....	371
Transit Shipments.....	372
Traction Engine Transportation.....	374
Motor Truck Transportation.....	374

	PAGE
Water Transportation.....	375
Vessels.....	375
Barges.....	376
Rafts.....	376

## CHAPTER XVIII

## DOMESTIC MARKETS

Methods of Sale.....	380
Wholesale.....	380
Retail.....	384
Lumber Advertising.....	387
Distribution.....	389
Factors which Control.....	389
Lumber Production.....	392
Lumber Consumption.....	393
Hardwood Markets.....	395
Softwood Markets.....	395
New England.....	395
North Carolina Pine Region.....	396
West Virginia.....	396
Lake States.....	397
Southern Yellow Pine Region.....	397
Cypress.....	398
Pacific Northwest.....	399
Redwood.....	400
Inland Empire.....	400

## CHAPTER XIX

## FOREIGN MARKETS

Early Foreign Markets.....	401
Volume of the Export Trade.....	401
Export Methods.....	405
Lumber Export Trade Co-operation.....	408
European Markets.....	409
Belgium.....	409
France.....	410
Germany.....	410
Holland.....	412
Italy.....	413
Portugal.....	414
Spain.....	414
United Kingdom.....	415
North American Markets.....	418
Canada.....	418
Mexico.....	419
South American Markets.....	420
Argentina.....	420
Brazil.....	421

	PAGE
Chile.....	422
Peru.....	423
West Indian Markets.....	423
Cuba.....	423
Asiatic Markets.....	424
China.....	424
Japan.....	425
Oceania Markets.....	425
Australia.....	425

## CHAPTER XX

## IMPORT TRADE-LUMBER TARIFF

Imports.....	427
Kind.....	427
Volume.....	427
Source.....	428
Lumber Tariff.....	429
Early Tariff Acts.....	429
Morrill Tariff Act.....	431
McKinley Tariff Act.....	431
Wilson Tariff Act.....	432
Dingley Tariff Act.....	432
Payne-Aldrich Tariff Act.....	433
Reciprocity with Canada.....	435
Underwood-Simmons Tariff Act.....	436

## APPENDIX

Bibliography.....	439
Terms Used in Lumber Manufacture and Distribution.....	449
Lumber Grades.....	484
Average Weights of Wood.....	493
Estimated Weights of Lumber.....	495
Official Standard Weights of Hardwood Lumber.....	496
Standard Sizes of Lumber.....	497
Average Shrinkage of Wood in Seasoning.....	503
How to Measure the Conditions in Seasoned Lumber.....	505
Lumber Production by States 1879-1920.....	506
Lumber Production by Species 1899-1920.....	508
Band Mill Data.....	510
Time Required to Saw Western Pine Logs.....	511
Saw Gauge Equivalents.....	512
Circular Saw Speeds and Number of Teeth.....	513
The Evaporative Value of Wood Fuel.....	514
Relative Fire Hazards of Refuse Burners.....	515
Material used in the Construction of a Framed Sawmill Building.....	516
Underwood-Simmons Tariff Act—Schedule D.....	517

## INTRODUCTION

---

THE manufacture of lumber was early developed in the United States, and for many years has been one of our most important industries. The first mills were built in Colonial times, along the North Atlantic seaboard. The industry gradually spread westward through New York, Pennsylvania, and the Central States into the Lake States and then turned to the southern pineries and to the forests of the Inland Empire and the Northwest. All of the forest regions of the United States, except the Inland Empire and the Pacific Coast States, have passed the peak of production, and each decade shows a marked decline in output over the preceding one.<sup>1</sup>

The early mills were simple in character and were equipped with a saw of the "mulay" type<sup>2</sup> and often were operated in connection with grist mills. They were driven by water-power, and had a daily output of a few hundred board feet only.

Lumber manufacture, as a large independent business, did not become a reality until the introduction of steam power into sawmills, the adaptation of the circular saw to lumber manufacture, the invention of the sash-gang saw, and the perfection of various labor-saving devices, all of which enabled operators to greatly increase their output.

The development of lumber manufacture west and south of New York and Pennsylvania did not begin until after the circular saw had come into use, and in the forest regions which have been opened up during the last seventy years, the circular saw or the later-developed band saw have supplanted the early pioneer type.

The general trend of the industry in all regions, except the Northwest, has been first the introduction of the small circular mill to supply the local needs of the settlers, followed by a later expansion as transportation facilities permitted the development of an outside market for the products of the forest. As the trade increased, the capacity of the mills also became greater and during the peak of production the

<sup>1</sup> The relative importance of the various producing regions during the last five decades is shown in Fig. 2. The actual production by states and by species is given in Tables XLI and XLV, in the Appendix.

<sup>2</sup> See page 3.

output was chiefly from these large mills. When virgin stands became depleted, the large mills decreased in numbers and the small mills again became the dominant factor in the industry because they could operate profitably on small scattered stands of virgin timber and in the areas of second-growth which the larger operators had not attempted to handle.

Although there always have been some small mills in the Northwest, they have never been an important factor because the large-sized timber requires powerful machinery to log and manufacture it. Owing to the sparse population, the local demands at first were very small, and the major part of the development of the forest resources followed the opening of the territory by trunk-line railroads which enabled lumber manufacturers to enter the markets of the prairie regions.

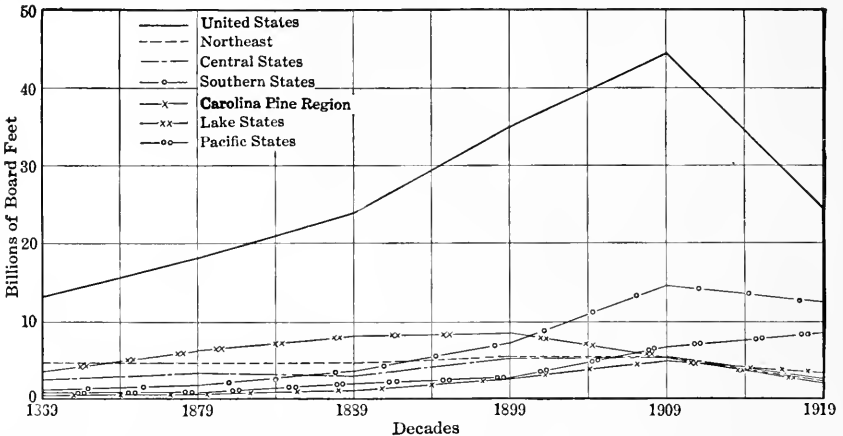

FIG. 2.—Lumber Production, by Decades, in the Several Forest Regions of the United States.

The big mill and the massive logging machinery now used on the Pacific Coast represent but a temporary phase in the lumber industry, because they will disappear with the passing of the large logs which they were designed to handle. The permanent type of plant in that region, which will manufacture the lumber cut from forests under management, will be one of relatively small capacity, designed for close utilization.

Sixty-five per cent of the lumber production of this country is manufactured in a relatively few large mills, which represent less than 5 per cent of the total number in the country.<sup>1</sup> Thirty-two per cent

<sup>1</sup>The total number of sawmills reported by the Bureau of Census in 1919 was 26,879. Table I shows the number of mills in each of the five classes, the production of each class, and the per cent of the total lumber production of the United States manufactured by each class.

of the large mills are located in the southern states; 25 per cent in the Pacific States; 12 per cent in the Lake States; 8 per cent in the North Carolina pine region; 4 per cent in the Rocky Mountain region, chiefly Idaho and Montana; 4 per cent in West Virginia; and 2 per cent in New England.

The small mill has always represented a large per cent of the total number. In 1919, 68.4 per cent of the total number of mills cut less than 500,000 board feet each, and produced only 17.8 per cent of the entire cut of the United States. These small mills are most numerous in the Southern States, which have 25.6 per cent of them; followed by the Northeastern States with 20.4 per cent; North Carolina pine region with 20 per cent; Central States with 18.8 per cent; Pacific States with 2.9 per cent; Rocky Mountain States with 2.9 per cent; and the Lake States with 2.5 per cent. They, therefore, are most numerous in the older and more densely populated portions of the country.

TABLE I.—NUMBER OF MILLS OPERATING AND PRODUCTION OF LUMBER: 1919\*

Class †	MILLS		QUANTITY CUT	
	Number ‡	Per cent	M feet b.m.	Per cent of total cut
All	26,879	100.00	34,467,509	100.00
5	792	2.9	18,814,099	54.6
4	503	1.9	3,544,609	10.3
3	3,211	11.9	5,972,196	17.3
2	3,977	14.8	2,662,855	7.7
1	18,396	68.4	3,473,750	10.1

\* From Fourteenth Census of the United States, 1919.

† Class 5—Mills cutting over 10,000 M bd. ft.

Class 4—Mills cutting from 5000 to 9999 M ft. b.m.

Class 3—Mills cutting from 1000 to 4999 M ft. b.m.

Class 2—Mills cutting from 500 to 999 M ft. b.m.

Class 1—Mills cutting from 50 to 499 M ft. b.m.

‡ Exclusive of mills cutting less than 50 M ft. b.m. per year.

### THE MANUFACTURING PROCESS <sup>1</sup>

The manufacturing procedure is similar in all regions without regard to species, although there may be variations in the process of re-manufacturing hardwoods and softwoods. Small mills lack many of

<sup>1</sup> The routing of sawmill products through a lumber manufacturing plant from pond to car is shown in Fig. 3.

the labor-saving devices and high-speed machines found in large mills, yet the general methods of manufacture vary only with the difference in equipment. Machinery for the re-manufacture of rough lumber is seldom found in small plants, therefore this operation must be performed in a factory not owned by the sawmill operator.

The following description of manufacture refers chiefly to plants of medium or large size which are equipped to place finished products on the market. The logs are delivered at the sawmill by water, rail, wagon, motor truck, or by some other form of wheeled transport and are stored either on land or in water until required for sawing purposes.

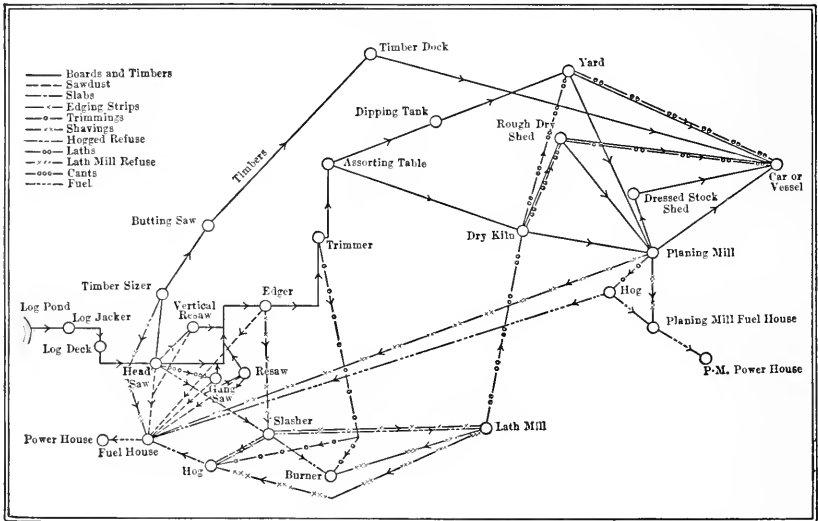

FIG. 3.—A Graphic Representation of the Routing of Sawmill Products from the Log Pond to the Car or Vessel. Absolute Position of Equipment or Direction of Travel of Products is not shown.

They are rolled upon the log decks of small mills by hand power and are brought to the decks of large mills by some form of power-driven device,<sup>1</sup> and when necessary are cut into shorter log lengths before they are thrown upon the deck.

Logs are taken singly from the deck, placed on the power-driven carriage and cut by means of the head-saw into the products desired. During the process of reducing the log to the sawed products, the log is turned, as often as required, to secure both the sizes desired and the highest quality of material.<sup>2</sup> The first cut on a log removes a slab which passes from the head-saw along a line of live rollers to the slasher,<sup>3</sup>

<sup>1</sup> See pages 26 to 35.

<sup>2</sup> The methods of sawing are described on pages 192 to 198.

<sup>3</sup> See page 107.



where it is cut into lengths suitable for lath stock, or for firewood. This material is then conveyed through the lath mill where lath stock is picked from the conveyor. Firewood for local consumption may be removed at some other point, the residue then being conveyed to a refuse burner, where it is burned, or to a refuse grinder or "hog," where it is converted into chips and then carried to the fuel storage house for use as fuel in the power house.

Small logs, which usually are "sawed alive," yield but two slabs, while larger logs which are "sawed around" yield four slabs. The thickness of slabs depends upon the sawing practice at the mill.<sup>1</sup>

Boards and dimension, as they are cut from the log, pass from the head-saw along the line of live rollers to a point in front of the edger, where they are shunted at right angles upon a storage table, from which they are taken by the edgerman, and run through the edger. During this process waney boards are made square-edged and wide boards ripped into narrower widths.<sup>2</sup> The boards and dimension as they leave the edger are shunted at right angles upon a storage table in front of the trimmer, while the waney-edged strips either are shunted upon conveyor chains leading to the slasher, or those of suitable width and length may be sent through the trimmer, then seasoned in a dry kiln, and later worked into narrow molding stock.

The boards and dimension are taken from the storage table in front of the trimmer and placed on the trimmer table up which they are carried by chains and trimmed to the desired length. Defective pieces are cut into shorter ones in order to secure the highest grade practicable without an undue waste of material. The trimmings from boards drop into a chute and are conveyed by chains either to the burner or to the refuse grinder. Short clear pieces may be removed from the conveyor and reworked into "shorts."

As the boards leave the trimmer they drop upon the grading and assorting table, where they are roughly graded and then assorted, often by species, grades, thicknesses, and lengths. The lumber is then taken either to the yard for air-seasoning or to the dry kilns for artificial seasoning. Common grades of softwood lumber often are air-dried,

<sup>1</sup> See pages 191 and 192.

<sup>2</sup> Second-growth white pine manufactured in New England is rarely made square-edged unless the lumber is cut from large logs. The "round-edged" or "waney-edged" boards are air-dried and when used in a wood-using factory they are cut into lengths suitable for box shooks or some form of novelties. Box-shook stock after it is cut to proper length is run through a rip saw and the wane removed, the resulting piece of lumber often being wedge-shaped. These pieces are then matched up with others to make a box side, top or bottom with parallel edges or cut into sizes required for some specific purpose. In this way it is possible to utilize logs which have a large amount of taper.

while the higher grades, as a rule, are kiln-dried to prevent sap stain.<sup>1</sup>

The lumber which is to be air-seasoned is carried to the yard and stored in front of the piling space, and later stacked in the pile by laborers using some hand or power method. When required for shipment, the lumber is removed from the pile, loaded on some conveyance and taken to the car, if it is to be shipped in the rough, or to the planing mill if it is to be surfaced or worked into some pattern or patterns. At the planing mill it is re-manufactured and as it leaves the machine, defects are cut from the ends, and the "off-grades"<sup>2</sup> are placed in storage sheds or re-stacked in the yard until there is an opportunity to ship them on an order calling for such stock. The accepted product from the machine is then loaded on a freight car for shipment.

Stock that is to be kiln-dried is taken from the assorting table to the kiln-stacking point, where it is loaded on trucks, either by hand or mechanical means, and then run into the drying chambers. When the drying process is completed the stock is removed, graded, and assorted and taken to a storage shed until required. It is then shipped in the rough, or worked to patterns in the planing mill where defects also are cut from the ends of the boards, and the lumber graded and placed in cars for shipment.

Certain classes of material, such as flooring strips, may be taken directly from the kiln to the planing mill and worked to pattern. This practice is not a common one, however, because pieces that are worked in a bone-dry condition are much more subject to machine defects, such as torn grain, than are those which have been stored in a shed for a short time, during which period the lumber absorbs some moisture which renders it less brittle, and fewer degradés are produced. Some mills, which work their stock direct from the dry kilns wet the truck loads of lumber by means of a hose, or submerge them in a tank of water for a moment which makes the lumber easier to work.

Timbers are handled in a different manner from boards and dimension, since they are shipped in a green condition. From the head-saw they pass down the line of live rollers to a "butting" or cut-off saw, where they are cut to proper length. They then pass on rollers to the timber sizer, if they are to be worked to exact sizes, and surfaced on one or more sides, and later moved to timber docks or ramps, where they are stored until a car load has been accumulated. They are then loaded on flat or gondola cars for shipment.

Timbers are cut on orders, that is, they are not carried in stock in standard sizes, hence they are manufactured only as they are to be

<sup>1</sup> See pages 219 to 222.

<sup>2</sup> Pieces which because of defects arising from re-manufacture or other causes do not meet the requirements of the specific order being filled.

shipped. Boards and dimension may or may not be cut to order, depending on the class of trade for which a given mill manufactures. Mills which sell to the general retail trade carry relatively large quantities of so-called "stock" sizes which are cut previous to their sale, as there is sufficient demand by the building trades for certain sizes to assure the mill a market for the product. Cargo or other mills cutting for a diversified class of buyers—"order mills,"—cut stock chiefly to fill orders, since there is such a great variation in the market requirements as to size that it is unwise to carry heavy stocks on hand.

A large per cent of the softwood lumber output of the larger mills of the country is either surfaced or worked to pattern at a planing mill operated in connection with the sawmill plant. The reason for this is that many products are more salable in some finished form than in the rough and there is a marked saving in freight on the waste material which is removed during the process of re-manufacture. Even though the product is of the lower or lowest grades and is to be used for some purpose which does not require surfaced material, the pieces usually are worked to standard size in order to reduce the weight.

Yard stock, in some sections, was formerly surfaced green before it was air-dried in the yard, because it was believed that the product seasoned more rapidly. This method also enabled the shipper to load out his seasoned stock directly from the pile. Woods like eastern hemlock were degraded less when worked green because the knots did not tear out in dressing to the extent they did after the boards had become shipping dry. This practice also prevailed to some extent in the eastern spruce, southern yellow pine, Douglas fir, redwood, and other softwood-producing regions. Green dressing of material, other than timbers, has now largely been abandoned because lumber shrinks and also becomes discolored after it is surfaced, and is not acceptable to the trade. Green dressing is not adapted to stock worked to patterns because of the shrinkage which takes place during the seasoning process.

Hardwood lumber is shipped chiefly in the rough. The boards are not used as a whole but are cut into smaller sizes suitable for the use of the wood-using industries. Some mill work is made at hardwood sawmill plants but this process of re-manufacture is of minor importance compared to re-manufacture at softwood plants.



PART I  
THE MANUFACTURING PLANT



# LUMBER

---

## CHAPTER I

### CHARACTER, LOCATION AND ARRANGEMENT

LUMBER-MANUFACTURING plants vary from the crude type used by the mountaineers in the United States, who whip-saw out a small quantity of lumber daily, to the modern plant of large size which cuts one million or more board feet of lumber in twenty-four hours.

#### CHARACTER

##### **Pit-sawing.**

This method of lumber manufacture, sometimes called whip-sawing, is still practiced in the Appalachian region of the United States and is a common means of cutting logs into lumber, especially in China, Japan, India, and the Philippines. The timber usually is roughly squared with a broadaxe and placed over a pit or else elevated 6 or 7 feet on a trestle. Saws of several patterns are used, one of which has a 6- or 7-foot blade resembling that of a cross-cut saw. A top sawyer stands on the upper side of the log and pulls the saw up, and a pitman stands underneath, and pulls the saw down. The saw cuts only on the downward stroke. The top of the log is scored with a chalk mark, which serves as a guide. Occasionally a spring pole, which raises the saw after each downward stroke, takes the place of the top sawyer. A day's work for two men is from 100 to 200 board feet of plank.

##### **Water-power Sawmill Plant.**

This was the first type of mill to be erected in this country, and it is still found in some communities. It had a single-blade saw, known as the "Mulay saw," which was held taut by an overhead spring pole and was worked up and down by a wooden beam attached to a crank on a water wheel. The saw was steadied by guide blocks, which exerted a side pressure. The sawing device was later modified, and the

saw was stretched in a sash running between side guides, the sash being actuated by a pitman which was fixed to its base. A later development of this idea resulted in hanging two or more saws in the sash—the forerunner of the present sash-gang saw.

The logs were supported on a crude carriage which was driven by a primitive form of ratchet feed works.<sup>1</sup> The carriage was giggered back by hand when the cut had been completed. The logs were set in place for a new cut by forcing the log over on the carriage with a crow-bar, the “set” being measured by a hand rule. Although sash saws are still in use in some small mills, they have been replaced, to a large extent, by circular saws.

### Portable Sawmill Plant.

Small, portable, steam-sawmill plants are common in all forested regions of this country, but are most numerous in the Northeast, the Appalachians, the South, and the Rocky Mountain region. They have a daily capacity ranging from 3000 to 10,000 board feet, and their product is sometimes a disturbing factor in the lumber markets, because the cost of manufacturing lumber in a portable mill is often less than in a large one and, therefore, the lumber may be offered at a lower price.

The amount of timber cut at one “set-up” varies from a few thousand to several hundred thousand board feet. The plant<sup>2</sup> is moved from one set-up to another on wheels, a shift of a few miles requiring usually about four days’ time, one day to dismantle the plant, one day to move it, and two days to set it up ready for operation. Four or five men, the normal mill crew, are required, also from four to eight horses for hauling, the number depending on the character of the roads and the weight of the equipment. Where contract sawing is done by the owner of the mill, it is sometimes customary for the stumpage owner to pay for moving the plant to his property, and also to furnish fuel for the operation of the plant.

### Floating Sawmill Plant.

During the early period of the sawmill industry in the South, floating sawmills, cutting lumber, spoke-stock, and hub-stock, were sometimes used on the bayous and other streams. The equipment of these mills, mounted on scows, comprised a head-saw, an edger, a trimmer and cut-off saws. The mills were steam-driven, but usually the

<sup>1</sup> See Early Sawmill Reminiscences. By Dan W. Baird. The Southern Lumberman. Nashville, Tenn., July 1, 1903, page 9.

<sup>2</sup> See Chapters II, III, IV, and VII for a description of the sawmill equipment.



barge was towed from one location to another by a river steamer. The sawed product was loaded on barges and towed to market or to some rail shipping point. Floating sawmill plants are rarely seen at the present time, since they are now unprofitable.

### **Semi-portable Sawmill Plant.**

There are comparatively few so-called semi-portable mills in use. The main difference between a semi-portable and a portable plant is that the equipment of the former is usually housed in some form of rough structure, and, in addition to a head-saw, often includes a single-saw edger, a one-saw or a two-saw trimmer, and sometimes a surfacing machine. Light band head-saws may be substituted for the circular head-saw, especially when lumber is manufactured from the more valuable woods, such as second-growth white pine. The so-called semi-portable band mills in the second-growth white pine region of New England average about 13,000 board feet daily. Such mills have seldom proved profitable where the amount of lumber sawed at each set-up was less than one million board feet.

### **Large Sawmill Plant.**

The lumber manufacturing machinery is well housed in a wooden-framed or a steel and concrete structure. The plant often is equipped with dry kilns, storage sheds for dry lumber, and planing mill facilities. The mill may have a circular head-saw, a band head-saw, a combination of both, or two or more band saws, either with or without a sash-gang saw and one or more re-saws.

They are suitable where a large quantity of timber is to be manufactured into lumber, thereby insuring a sufficient life to the plant to warrant a reasonable depreciation charge. As a rule, a single-band or larger mill should have at least ten years' life in order to warrant its construction. The ten-hour capacity of a softwood mill with a single circular head-saw is from 25,000 to 50,000 board feet, a single band head-saw from 40,000 to 50,000 feet, and a mill with two band head-saws 100,000 board feet. The output for hardwoods as compared to softwoods is from 25 to 30 per cent less.

## PLANT LOCATION AND ARRANGEMENT

The factors which influence the location and arrangement of a lumber manufacturing plant are dependent chiefly on the character of the plant; that is, whether it is a water-power, a portable steam, a semi-permanent steam, or a large permanent plant.

### Location.

The first requisite of a water-power mill is a sufficient head of water to drive the mill, so located that the timber is within a reasonable hauling distance. Water-power sawmills are frequently combined with grist mills, and hence they often are farther from the timber than is desirable for the most profitable operation. The lumber usually is sawed for custom trade, farmers bringing in logs to be cut into lumber for their own use. Water-power sawmills which annually cut more than a few hundred thousand board feet of lumber are now few in number.

Steam portable sawmill plants are located as close to the timber as practicable, to reduce the logging expense. Camps seldom are required, since portable work is carried on in fairly well-settled communities. The chief factors involved in choosing a camp location are the following: proximity to the standing timber; an ample water supply close at hand for the boiler; sufficient storage area for the sawed lumber, unless it is to be hauled directly from the saw to market or hauled out and stored along a highway; and accessibility to good roads leading to market.

Semi-portable sawmill plants, in which from one to several million board feet of lumber are sawed at one set-up, require a suitable site for a few buildings, to house at least a portion of the workmen; they also require an ample water supply for domestic and power purposes, a storage area large enough to provide piling space for several hundred thousand board feet of lumber, and accessibility to market.

Although sawmill plants having a large daily capacity differ in numerous respects in their location requirements, the following features are common to all:

1. There must be adequate facilities both for bringing the raw product to the plant and for transporting the manufactured product to market.

When logs are to be floated or rafted to the mill, it is obvious that the plant must be located either on a stream or on the shore of a lake, or on tide-water. If the logs are driven down some stream, the choice of site is limited to points along that stream or on some other body of water tributary to it, at which facilities may be developed for moving the sawed material to market. If the product is to be moved in boats the manufacturing site should possess a suitable place for vessels to tie up and load, while if it is to be moved by rail, the plant must be erected at some point which is accessible, at a reasonable cost, to a trunk-line railroad.

On large bodies of water, such as lakes or tide-water, the site must offer protection from storms, both to vessels and to the property, and

must also have an area of sheltered water large enough for the storage of the log supply.

It may happen that the timber is adjacent to a stream, whose course would take the logs to points where they would not be accessible to a manufacturing plant site, or where there are no adequate facilities for transporting the product to market. In some sections there may be an absence of streams of sufficient size to make log-floating possible; moreover, many species now merchantable cannot be floated without a heavy loss. In such cases provision is made to bring the logs to the mill by some form of land transport, preferably a logging railroad, if the topography and volume of timber to be handled renders this practicable.

Proximity to the supply of raw material is of greater importance where the timber is to be brought to the plant by rail than when it is to be floated. Land transport is the more expensive method for long distances, if the lumberman must construct the mileage of road necessary to reach the timber. This would not be true, however, in the case of a logging railroad which taps a region furnishing a sufficient tonnage, other than logs and lumber products, to make the railroad profitable as a common carrier. There are instances where logs have been transported for distances of 100 or more miles on trunk-line roads, in order to bring remote timber to a plant already established, or to manufacture the raw product at some point where water transport to market is available, preferably where sea-going vessels may be loaded directly from the docks at the mill.

When there is a good market for slabs, sawdust, and other mill refuse, manufacturers sometimes find it desirable to locate their plant near some large center and to haul their logs for long distances. In such cases the refuse sometimes can be sold for pulpwood, firewood, and other uses, for a sum sufficient to offset the cost of the long haul for the raw product.

2. There must be a sufficient area of fairly level ground on which to locate the manufacturing plant and on which to store the lumber while it is being seasoned or held for market. The area required depends upon the daily capacity of the plant, the seasoning method employed, the length of time the stock is kept on hand, and also on the value of the land on which the plant is located. When the plant site is in a city where land is valuable, the tendency is to concentrate the buildings within a limited space, and to pile lumber much higher than is the case in communities where land is less valuable.

In a rural community a plant with a daily capacity of 100,000 board feet will cover about 25 acres when from 7 to 8 million board feet of lumber are carried in the yards. This area will permit

standard insurance distances between the various buildings and the yard, and will not necessitate piling lumber to a height exceeding 16 feet above the tram level. When the plant is located in a narrow valley, the area is reduced, and the piles on the flat are made higher because it is not profitable to haul up-hill to the piling ground.

3. There should be natural water storage for logs which will float, since they can be stored and handled in water more cheaply than on land. The pond capacity should be equal at least to three or four times the daily mill requirements. If water storage is not available or the logs will not float, the latter are either placed on rollways or decked in high piles by machinery.

4. There should be a well-drained site for the quarters of such employees as live near the plant. An abundant supply of pure water must be provided, preferably from deep driven wells, and suitable sanitary regulations enforced. When the sawmill is located on the outskirts of an established community the laborers can be secured from the local population, but when a plant is built in an undeveloped section the operator may find it necessary to erect buildings in which to house the workmen and their families.

#### CHARACTER OF SETTLEMENT

The buildings constructed for a portable steam plant are rough structures and may consist merely of a bunk house for housing the men, and a cook shanty. The families of the workmen sometimes live at the settlement, in which case small one-storied two-room shanties are constructed of rough lumber. From four to six houses, in addition to stables for the animals, are adequate for a plant with a daily output of from 10,000 to 12,000 board feet. A small commissary, in which supplies are offered for sale, may be operated in connection with the plant.

When a large manufacturing plant is built in a settled community, the company may own only a few buildings outside of those necessary for the conduct of the business. It is customary to maintain a commissary, in which a general line of merchandise and foodstuffs is carried, and, in addition, there may be a few dwellings occupied by the higher officials of the company. The plant and buildings are located outside of the city, if possible, in order to avoid a high rate of taxation. Light and water are generally provided from the sawmill plant.

A manufacturer often locates his plant away from existing settlements in order to be in close proximity to the timber. Such a settlement, comprising several hundred or a few thousand inhabitants, may be without any organized form of government, the admin-

istration and police functions being under the control of the officials of the company. These towns, known as "one-man" towns, are among the most orderly and prosperous communities in the region, as only high-class laborers are permitted to reside in them, and they are only found where the company retains control of the land in the vicinity of the settlement. They sometimes are incorporated, and the municipal affairs are regulated by officials elected by the people. In such cases, it is necessary for one or more residents to own property within the village limits.

There is a great diversity in the character of the dwellings in these towns. The buildings may be small and rough in character, and arranged in long rows, without regard to civic beauty. However, when the company takes pride in its village, the houses are painted, and have electric lights and running water; lawns are well kept, the streets are laid out uniformly, and an attractive church, school, and club house are provided. Most of the structures are built of wood, but in some cases brick is used for office buildings. Where both whites and negroes are employed, they are segregated. A village which houses the employees of a sawmill having a daily output of 100,000 board feet contains from 200 to 250 houses, exclusive of the boarding houses where single men live. Such a village, including the area required for streets, will ordinarily cover from 60 to 75 acres.

#### GENERAL ARRANGEMENT OF PLANT

At portable and semi-portable plants, the location of the plant and storage yard, with reference to each other, have little uniformity, being made to conform, as cheaply as possible, to the available land and the topography. Since portable plants are temporary in character, a make-shift arrangement may be used which would not be considered if the plant were semi-permanent in character. A yard in the immediate vicinity may be dispensed with, the green sawed product being hauled to some area along a good transportation route or direct to market, as conditions may warrant. A semi-portable plant has a yard storage area which is so located that lumber can be readily moved to it from the saw, and the seasoned product can later be brought to the planer or loaded on some transport device for movement to market.

Large permanent establishments require a well-laid-out plan for the location of each part of the plant, so that the product passes by an orderly process from one department to another from the time the logs reach the mill until the material is loaded on cars or vessels for shipment to market.

Sawmill plants sell their products to many classes of trade, requiring

differences in plant equipment, and transportation facilities; furthermore, there are local topographic differences in site, all of which tend to variety in the relative location of buildings, yards, and other plant accessories. There are, however, certain general underlying principles which are kept in mind in preparing the ground plan for a large plant.

The method of storing logs is one of the chief factors in determining the sawmill site; hence the location of the remaining part of the plant is secondary to the site of the sawmill proper. The sawed material

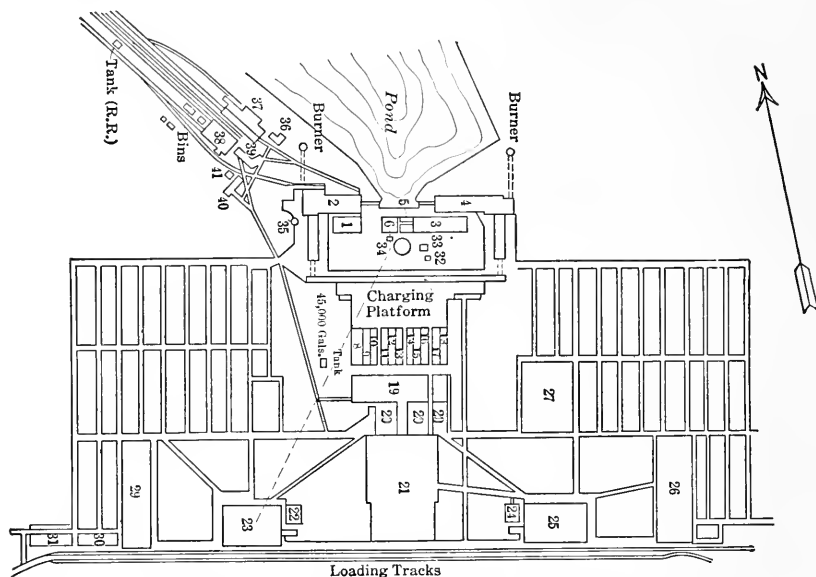

FIG. 4.—The Ground Plan of a Southern Pine Sawmill Plant having Two Sawmill Units. 1 and 3. Sawmill Power Plants. 2 and 4. Sawmill Buildings. 5. Electric Light Plant. 6. Fuel House. 8 to 18, inc. Dry Kilns. 19. Cooling Shed for Kiln-dried Lumber. 20. Kiln-truck Unloading Platforms. 21, 26, 27, 29, 30, and 31. Lumber Storage Sheds for Kiln-dried and Dressed Stock. 22 and 24. Power Houses for the Planing Mills. 23 and 25. Planing Mills. 32 and 36. Pump Houses. 37. Blacksmith and Car Repair Shop. 38. Round House. 39. Machine Shop. 40. Carpenter Shop. 41. Tinsmith Shop.

should pass from the mill, through all the various processes of seasoning and re-manufacture, in such a direction that the product does not return to any part of the plant through which it has previously passed; otherwise the expense of handling is increased. Where lumber is trucked by hand or by animal-power, it should move through all of the stages of manufacture on a slight down-grade from the tail of the sawmill to the car or vessel. This facilitates handling and makes possible the movement of maximum loads with minimum effort.

The chief equipment of a large lumber-manufacturing plant comprises the log storage facilities, either on dry land or in water, the sawmill and power plant, fuel house, refuse burner, yards, dry kilns, "rough dry" and "finish" storage sheds, planing mill and power plant, machine shop, loading platform, and small buildings which may include a pump house, dynamo house, supply house, and office. Other minor buildings may be required to house miscellaneous equipment.

The arrangement of the various parts of one large sawmill plant are shown in the general plan, Fig. 4, of a southern pine operation having an annual capacity of approximately 80 million board feet of lumber. This plant has two sawing units, one dry kiln unit, two storage yards, and two planing mill units.

The lumber from both sawing units is sent either to the dry kiln or to one or the other of the yards, according to its quality and size. It does not again come together until it is loaded out from the shipping platform.

## CHAPTER II

### LOG STORAGE

#### LAND STORAGE

PORTABLE mills often saw the logs as they are skidded and therefore only a small number are accumulated at the mill. Occasionally a single band mill cutting either hardwoods or softwoods dispenses with a storage yard.<sup>1</sup>

#### Rollway.

Mills having a daily capacity of 15,000 feet or more, log scale, find it necessary to accumulate a surplus of logs, in order that the plant may continue to operate even though the daily supply of logs coming from the forest is temporarily interrupted. In this case the logs are stored on a rollway, which may extend on one or both sides of the device used for transporting logs from the storage point into the mill.<sup>2</sup> The rollway extends away from the head of the mill but in a direction parallel to it. The length varies with the storage capacity desired but should be sufficient to store at least a two-day or three-day supply of raw material. Where logs are brought to the mill by rail transport, the rollway should be long enough to permit the usual number of loaded cars to be spotted and then unloaded without the further services of a locomotive.

The rollway consists of a substantial crib work upon which round or square skids are placed 6 or 8 feet apart. The skids run at right angles to the main axis of the mill and slope gradually downward away from the point of unloading, so that logs can be rolled readily toward the equipment used for conveying the logs into the mill. The height of the outer ends of the skids should be slightly less than the top of the bunks of the cars or other vehicles on which the logs are brought to the mill, and the lower end of the skids should be slightly above the bunks of the car used for transporting the logs into the mill. Chock blocks, placed at the lower end of the skids, hold the logs in place until they are required for sawing. The width of the rollway should be sufficient

<sup>1</sup> See page 29.

<sup>2</sup> See pages 26 to 35.



to hold, single decked, one car load or several wagon loads of logs. A length of 250 feet usually is adequate for a mill with a single head-saw.

### Cableway System.

A cableway system, operated on the general principles of the cableway logging system, has been installed at some large plants where dry storage is used for logs which have been brought to the mill by rail. The logs may be unloaded from cars and decked in large piles; taken from cars or from decked piles to the foot of the jack ladder of the sawmill; or placed directly on the log deck.

Equipment of this character was installed at a spruce-lumber manufacturing plant in New Hampshire, which had a shallow log pond capable of holding only a few car loads of logs. It was necessary to store from 100,000 to 300,000 feet of logs daily, during the hauling season. At first the logs were decked by hand in the shallow parts of the pond, but this method necessitated a large amount of manual labor both at the time the logs were decked and also at a later time when it became necessary to roll the logs from the piles into deep water so that they could be moved into the mill. A cableway system, which had a span of 576 feet, was installed to facilitate log storage. The main cable was suspended between a head tower 57 feet high, which carried the trolley-operating machinery, and a tail tower 69 feet high, which supported the tail blocks. Both towers were mounted on trucks and were self-propelling, and traveled on parallel tracks, one of which was on each side of the pond. The logging railroad was located between the head tower track and the pond, so that the cable supporting the trolley spanned both the unloading track and the entire width of the storage area, which was 300 feet wide and 700 feet long.

The device had a carrying capacity of 5 tons. Electricity developed at the plant was used for power. The logs were unloaded from the cars and decked in high piles as they were brought to the mill; when they were needed for sawing purposes the cableway system was used

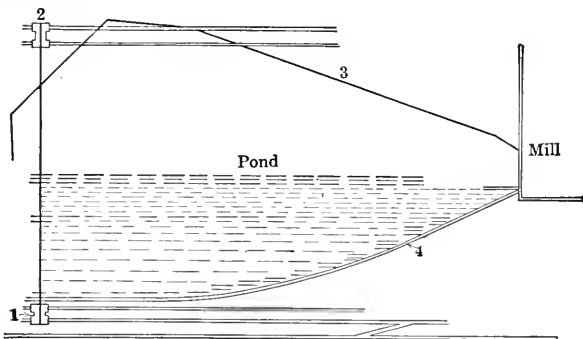

FIG. 5.—A Cableway System for assorting and piling Logs in a Sawmill Pond. 1. The Traveling Head Spar. 2. The Traveling Tail Spar. 3. A Timber Dam. 4. The Railroad Tract skirting One Side of the Pond.

they were needed for sawing purposes the cableway system was used

to break down the piles and place the logs in deep water so that they could be floated to the jack ladder. The general arrangement of the system with reference to the pond and mill is shown in Fig. 5. An overhead system<sup>1</sup> was devised for the Japanese Government in 1914, for assorting and decking hardwood logs which were to be brought to the sawmill plant by a logging railroad, and also for breaking down the piles and delivering the stored logs at the foot of the jack ladder. The maximum hoisting speed of the equipment was 200 feet per minute, and the maximum trolley speed was 800 feet per minute. The span between towers was 400 feet. The machine had a lifting capacity of 16 tons and an estimated daily capacity of 250,000 board feet. A similar system is also used at some hardwood plants in this country.

### Monorail.<sup>2</sup>

The monorail system has recently been adapted to log storage and assorting purposes. The logging railroad track crosses the main line and spurs of the monorail system, and the logs are taken from the cars in bundles containing about 800 feet, log scale, which are either delivered at the terminus of an endless chain leading to the jack ladder, or placed in piles between the monorail trestle legs. The surplus logs are decked in piles to a maximum height of 24 feet, the storage capacity at a plant being limited only by the length of main line and spurs provided.

When logs are taken from the cars directly to the endless chain, the ten-hour capacity of one monorail hoist is about 65,000 feet, log scale; when logs are assorted and a portion of them decked and the remainder taken to the mill, the daily capacity of one hoist may be reduced to 40,000 feet, log scale.<sup>3</sup>

### Other Devices.

Other types of log-unloading and log-assorting devices used at large hardwood sawmill plants comprise either a long boom mounted upon a non-portable base, often of concrete, provided with a hoisting engine and cable and blocks; or a similar machine, portable in character, which travels either on a wide-gauge track which spans the logging railroad or on a track parallel to the railroad, the logs on the loaded cars being within reach of the boom. The latter is of the swinging type and usually is from 30 to 40 feet in length.

<sup>1</sup> Designed and built by the Lidgerwood Manufacturing Co., New York.

<sup>2</sup> The details of a monorail system for handling lumber are described on pages 145 to 148.

<sup>3</sup> See American Lumberman, Chicago, Ill., Nov. 12, 1921, page 44.

One such unloading device has an elevated derrick, traveling on its own track and under its own power, and equipped with a boom which is 70 feet in length. The derrick track, having a gauge of 28 feet, parallels the railroad on one side and the log haul-up on the other side. Logs may either be placed on the haul-up or assorted and stored in piles in one of three places, namely, between the railroad and derrick, between the derrick and haul-up, and in the space between the derrick rails, the frame work of the unloader being high enough to clear piles six or eight logs high. The advantage of this type is that the storage space is limited only by the length of track on which the unloader travels, and also that logs can be assorted as to size, species, and quality if so desired. A storage capacity of from 3 to 6 million feet, log scale, often is provided.

An unloader of the portable type, operated by steam power, which straddles the railroad track and is used to unload log cars, to assort and pile logs and also to place them on the elevating device which carries them into the mill, is shown in Fig. 6.



FIG. 6.—A Portable Log Unloader and Stacker for Hardwood Operations.

The non-portable type is used both to unload cars and to deck the logs in piles from 20 to 30 feet high in a semicircle around the machine, or else to place the logs directly on the log haul-up. The capacity of the storage space available to a machine of this character is approximately 500,000 feet, log scale.

Locomotive cranes<sup>1</sup> are used at some plants which purchase logs that are delivered at the mill by trunk-line railroads. These cranes are used not only to unload the logs from the cars and to deck them, but also to take the logs from the piles and place them on the jacker chain.

<sup>1</sup> Fig. 7.

## WATER STORAGE

**Storage Areas.**

Log storage reservoirs may be ponds, either natural or artificial; pockets on small streams; or impounded areas on rivers, lakes, or tide-water, where a sheltered spot can be secured and enclosed with boom sticks. A storage space in the channel of a large stream or at an exposed point on a large body of water is less desirable than a pond,



*Photograph by Industrial Works, Bay City, Mich.*

FIG. 7.—A Locomotive Crane used in unloading, assorting, and piling Hardwood Logs.

because floods or storms may destroy the impounding works and scatter the logs.

The size of the storage area is governed by the natural advantages present and the daily or annual requirements of the plant.<sup>1</sup> When logs are brought to the storage point by rail or by raft, it is customary to carry, at least, a few days' log supply. When logs are floated to the

<sup>1</sup>An acre of water will store approximately 250,000 board feet of medium-sized, standard-length logs, provided they are crowded together. Small logs require a larger area than large logs for a given quantity. See "Boom Areas," by A. M. Carter, *Forestry Quarterly*, Vol. X, No. 1, page 15.

mill, the storage area must be ample to accommodate a large part of the annual cut, although a portion of the season's supply may be held in reserve above the storage point and floated down during the latter part of the season. The storage space on streams in which there is a strong current should be up-stream from the mill, because it is difficult to move logs by hand against the current.

Log storage areas are divided, by booms, into several pockets, in order that logs may be assorted by species, size, grade, or floating ability. The outer limits of the impounded area in streams or on large bodies of water are delimited by clusters of piling<sup>1</sup> to which the boom sticks are fastened. The booms delimiting pockets on ponds require single piles only, to hold them in place.

On large streams or other bodies of water where it is illegal to float loose logs because of the menace to navigation, logs must be rafted and towed to the mill. This must also be done where permanent storage works are not permitted because of their interference with navigation.

The storage basins should be so deep that they will not become clogged with sunken logs and debris. In still water, especially on ponds, they require constant attention unless they have a depth of from 10 to 12 feet, and even then it is necessary to continually remove sunken logs from the vicinity of the dumping ground. Less trouble is experienced when logs are dumped and stored in streams, because the current tends to keep the area free from obstructions. Logs driven down streams deposit less rubbish on the storage ground than those brought in on a railroad, because they have lost their loose bark in transit.

A natural basin of sufficient size rarely is available for a log pond, and it may be necessary to build embankments to confine the water, and also to deepen the proposed pond area by excavation.

The water supply for ponds may be furnished by a stream and by surface drainage, or water may be pumped into the basin from some outside source, such as a well or a large stream, or from both. A natural supply is secured whenever practicable, because the cost of maintenance is less. It is necessary to provide spillways, by means of which surplus flood water can be carried off without damage to the embankments.

Facilities for unloading logs from cars must be provided at the mill pond. An inclined rollway of sufficient length to accommodate a train of log cars is usually built along one or more sides of the pond, at a point from which logs can be readily poled to the foot of the jack ladder. The railroad track, which parallels this rollway, has the outer rail elevated from 12 to 15 inches to facilitate the unloading of logs. Many logs will roll, by gravity, from the car, upon the rollway and into

<sup>1</sup> Where there is danger of ice damage, the piling is protected by cribbing.

the pond, when the binding chains, stakes, chock blocks, or other devices used for holding them on the cars have been removed.

### Hot Pond.

In northern regions, sawmills which depend on the streams as a means of transport for their log supply formerly ran only during the open season, when the streams were sufficiently free from ice to permit handling logs. In many cases the sawing season was from five to six months only. About the year 1890 mills in the Lake States began to install "hot ponds," which enabled them to extend their sawing period throughout the greater part of the year.<sup>1</sup>

A hot pond is an enclosed water area, devoid of any current, into which hot water or exhaust steam is discharged. This keeps the pond open, and also tends to thaw the logs and to free them from gravel and dirt. Logs may be delivered into the hot pond directly from log cars; rolled into it from piles on the bank which have been decked up during the season of open water, or placed in it by a cableway system.

The hot pond equipment<sup>2</sup> used by a mill in Wisconsin is shown in Fig. 8. The log pond, 150 by 350 feet in size, was surrounded by a tight enclosure made from dressed and matched dimension, the lower ends of which were driven into solid earth. The hot water for heating the pond was secured from two sources, namely, from water heated by the condensed steam from the plant and from water which was passed through coils in the refuse burner. The condenser was made from an old two-flue boiler, from which the tubes had been removed and the openings patched to make the boiler tight. It was placed near the edge of the pond, and all exhaust steam from the sawmill turned into it. A 3½-inch perforated water pipe entered the head of the condenser, and extended nearly its entire length. When cold water was forced through this feed pipe it entered the condenser in the form of a spray, which condensed the exhaust steam, and heated the water to a fairly high temperature. The outlets from the condenser were two pipes, one of which entered the "hot pond" in front of the condenser, while the other extended partly around the pond and discharged in two places opposite the plant. A water heater, consisting of eight cylinders each 14 inches in diameter and 20 feet long, was installed in the refuse

<sup>1</sup> In the issue of the *Northwestern Lumberman*, Chicago, Ill., dated November 5, 1892, the statement is made that "a number of the leading mills in Michigan and Wisconsin have already been equipped for winter sawing, and will be run to their full capacity during the coming winter." The addition of "hot ponds" to the plant equipment made this possible.

<sup>2</sup> Described in the *Mississippi Valley Lumberman*, Minneapolis, Minn., November 17, 1899.

burner, and comprised the second source of hot water. These cylinders were placed upright and connected alternately at top and bottom with 3-inch fittings. Water from the pond was pumped through this heater and discharged back into the pond at three different points.

The ends of the pipes through which the hot water was delivered to the pond were horizontal and on a level with the water, so that the hot water was shot out over the surface. Exhaust steam and the water heated by the refuse burner kept the pond open, even when the thermometer fell as low as  $40^{\circ}$  F. below zero.

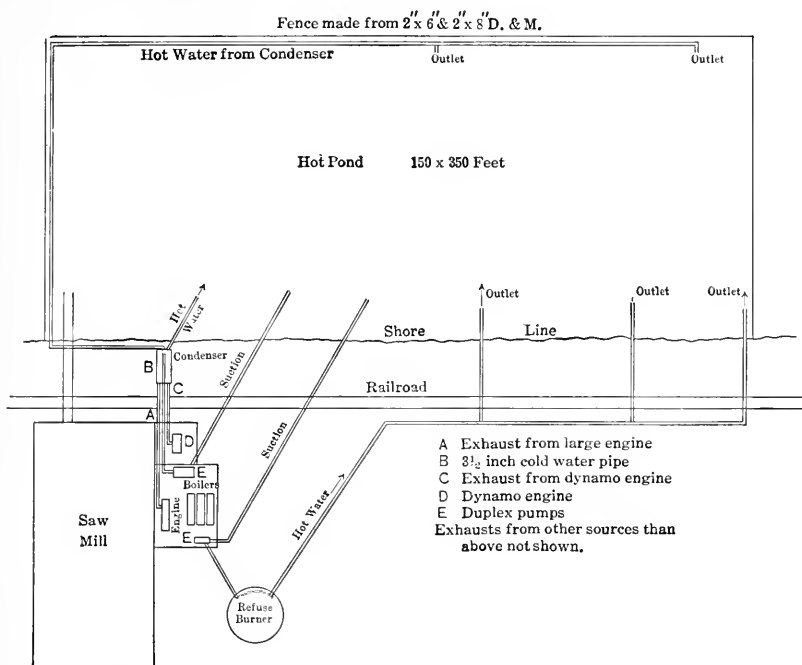

FIG. 8.—The Ground Plan of a Hot Pond for a Northern Sawmill.

Although pumping water from the hot pond for boiler use would tend to keep the water in circulation, it was found undesirable to do this, because after a few weeks the pond water contained too much pitch and too many other impurities to be suitable for boiler use.

Many adaptations of the "hot pond" idea have been devised but, in principle, they have been similar to the one described. Some enclosed hot ponds have been wholly or partially roofed over to conserve heat, but this form has not been as common as the open type.

### Pond Cleaning.

It is necessary to keep shallow log ponds free from sunken logs, so that the storage area will not become clogged. A small craft called a

catamaran, of which there are many types, is generally used in raising sunken logs. One design has two pontoons approximately 4 feet wide, 16 feet long, and 2 feet deep, made of 2-inch plank, across which are two 6- by 6-inch by 16-foot timbers, placed at right angles in such a way that the pontoons will be held parallel and 4 feet apart, the cross-timbers projecting 2 feet over each side of the pontoons. The cross-timbers are placed  $2\frac{1}{2}$  feet from the ends of the pontoons, which makes the distance between them 11 feet. Chains are fastened to the cross-timbers between the pontoons and also to their projecting ends. These chains are about 12 inches long and are made from  $\frac{3}{8}$ - or  $\frac{1}{2}$ -inch iron. Log dogs are attached to the free ends of the chains and are driven into the logs and serve to hold them upon the surface when once they have been raised.

The catamaran, usually manned by a crew of two, is poled over the sunken logs, and the latter are raised by means of pike poles. The logs are brought to the surface, parallel to the pontoons, and are fastened to the cross-timbers by means of the log dogs, one dog on each cross-timber being driven into the log. When several logs have been raised, the catamaran is poled to the foot of the jack ladder and the logs released and sent into the mill. Two men can raise from 100 to 125 logs per day. Where the storage area is extensive a different procedure may be followed. In this case, the logs are brought to the surface between pontoons spaced from 10 to 12 feet apart. From six to eight "dead-heads" are made into a raft by means of short cross-timbers and log dogs, the whole being buoyed up by two "floaters," one of which is fastened on each side of the raised logs. The raft is then turned loose in the pond and later is taken to the foot of the jack ladder by the regular pond force. Two men can raise and raft from 125 to 140 logs per day by this method. A catamaran for raising very large logs is equipped with a windlass which spans the gap between the two pontoons. The logs are raised by means of tongs attached to the manila rope on the windlass.

A large per cent of the logs which will sink go down soon after they are placed in the water; hence the greatest number of "sinkers" are found near the rollway.

Bark from logs rapidly fills up the basin near the dumping point, especially in still water, and it is necessary to clean the bed of the storage area at occasional intervals. This is done in various ways. Sometimes a dredge, with a long boom and an orange-peel bucket, is mounted on a flat car and used to remove the debris along the rollway. In other cases a centrifugal pump, mounted on a barge, is used to suck the debris from the bottom and to force it through pipes to a dumping point outside of the impounded area. Dredge boats, equipped with a



dipper or an endless chain with buckets, may be floated in the pond and used for this purpose, if such equipment is available. Where dredging machinery is not at hand, the water may be drained from the pond; then the logs may be removed by means of a power-driven drum and a cable, and the debris dragged out by a scoop operated by a re-haul line; or a railroad track may be laid on the bed of the pond and the debris loaded on cars and hauled away.

The frequency of cleaning is dependent on local conditions, depth of pond, and character of timber. As a rule, the debris must be partially or wholly removed annually or biennially.

### **Pond Crew.**

The crew required for the operation of a pond varies with the pond area, the amount of timber handled daily, and the log-handling facilities provided. As a rule, a crew handling from 100,000 to 150,000 feet, log scale, per shift would comprise eight men, namely, one pond foreman, one jacker feeder, two men to bring logs to the foot of the jack ladder, two sinker raisers, and two car unloaders. The car unloaders may also keep the railroad track free from debris and aid in other work as their time is not fully occupied by unloading. In some cases the unloaders are dispensed with, the train crew performing this work.

The equipment for handling logs includes pike poles, peavies, catamarans, bracket booms near the jack ladder, which serve as runways for the men, and a single-stick timber boom. One end of the timber boom is carried around a group of logs, and a rope or cable on the free end is attached to a windlass on shore near the jack ladder, and the impounded logs are pulled in so that they will be within easy reach of the point where they enter the mill. Pond work may be done by contract, the foreman being the contractor and hiring the pond men. The basis of the contract is the amount of timber handled.

## CHAPTER III

### SAWMILL EQUIPMENT

#### THE BUILDING <sup>1</sup>

SAWMILL machinery is usually housed in wooden structures, although, some steel-and-concrete buildings have been erected, in recent years, at certain plants where the output is large. Both types have their merits. A wooden-framed structure can be built more cheaply, because the material can be sawed in the vicinity, from stumpage owned by the operator; it can also be easily repaired, and altered, and additions can be made with a minimum of effort. It is less noisy than a steel-and-concrete building. It is, however, subject to rather rapid deterioration, especially under the log deck, where the timbers are moist for the greater part of the time. The supporting timbers in such cases must be replaced every few years, unless treated with creosote.

The fire hazard is greater with a wooden structure, although a steel-and-concrete building, if not kept clean, may be seriously damaged by fire. It is more difficult to repair a steel structure damaged by fire than a wooden one, because the structural beams have to be cut out and removed. Steel-and-concrete sawmill buildings have been erected chiefly because of the lower fire hazard.

Concrete, because of its permanent character, is now used for the foundations of all large wooden sawmill buildings, provided a solid bottom can be secured. If the foundation is properly constructed, as to size of base and quality of material used, it will not settle. The latter fault leads to endless trouble in a sawmill, throwing shafting and other equipment out of alignment; in this way, it may cause bearings and saws to heat, resulting both in serious damage to machinery and in a loss of time, due to enforced shutdowns. Piling must be used for foundations on marshy ground, or where a solid bottom can be reached only at a considerable depth.

There is not much variation in the dimensions of buildings housing similar machines as the character of machines and the necessary space for their operation are fairly well standardized.

<sup>1</sup> No attempt is made to describe the structural details.

SEMI-PORTABLE MILL (Uncovered Log Deck)

BOILER OUTSIDE

Scale  $\frac{1}{4}'' = 10'$

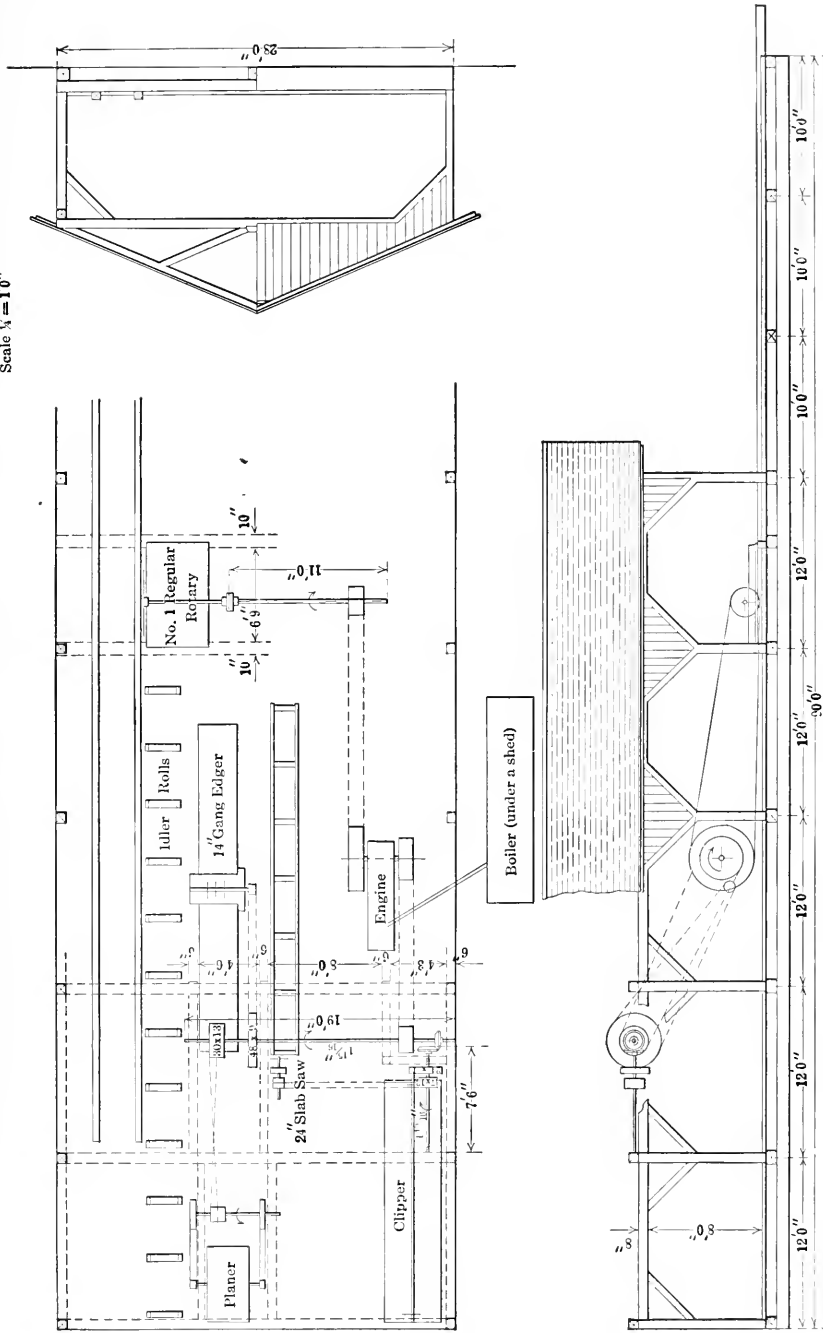

By permission Lane Mfg. Co.

FIG. 9.—The Sawing Floor and the Side and End Elevations of the Building of a One-storied Semi-portable Sawmill with a Circular Head-saw.

The housing for a semi-portable plant is one-storied; a permanent mill building with a circular head-saw is two-storied; and one with a band head-saw is two-storied in the main part, but has an additional superstructure over the head-saw to house the filing equipment. Shafting, engines, steam nigger and log-stop and loader cylinders, refuse conveyors, and similar equipment are placed on the first floor, and the lumber manufacturing machinery, such as head-saws, edgers, trimmers, slashers, transfers, and other accessories, on the second floor.

A plan for a semi-portable circular mill,<sup>1</sup> with its housing, is shown in Fig. 9; and the structural features for a building housing a mill with one band head-saw and one resaw<sup>2</sup> are shown in Fig. 10. A two-band head-saw mill building does not differ greatly from the latter. The dimensions of the ground plan of the building shown for the semi-portable plant are 28 by 90 feet; while on the end elevation the distance from floor to eaves is 9 feet, and from floor to peak of roof 15 feet. Single-band saw-mills usually have a ground floor space approximating 40 by 160 feet. A two-band head-saw mill ranges in width from 56 to 60 feet, and its length varies according to the amount of special machinery which is installed at the rear.

The size of the supporting concrete bases depends upon the character of bottom. A base 4 by 4 feet in size, narrowed to 2 feet at the top, is adequate if it rests on solid bottom below the frost line and projects high enough above the floor level to prevent the base of the wooden posts from coming into contact with the ground moisture. The wooden supporting posts on the ground floor usually are 12 by 12 inches in cross-section; those on the second floor, 10 by 10 inches; and those supporting the roof of the third story, the filing room, 8 by 10 inches. The floor joists and braces vary in size in accordance with the weight supported. Their arrangement is shown in Figs. 9 and 10. The amount of material used in the construction of a two-storied wooden-framed sawmill building, with a filing room above, may be found in the Appendix, pages 439 to 518.

#### ELEVATION OF LOGS INTO THE MILL

Portable and semi-portable mills usually have the sawing equipment on the ground floor, so that it is not necessary to elevate the logs to the sawing floor. As a general rule, the carriage head blocks<sup>3</sup> are on a level with the storage point or slightly below it, so that logs can be placed on the carriage by hand labor. Mills having a daily capacity

<sup>1</sup> Designed by the Lane Manufacturing Co., Montpelier, Vt.

<sup>2</sup> Designed by M. Garland Co., Bay City, Mich.

<sup>3</sup> See page 56.

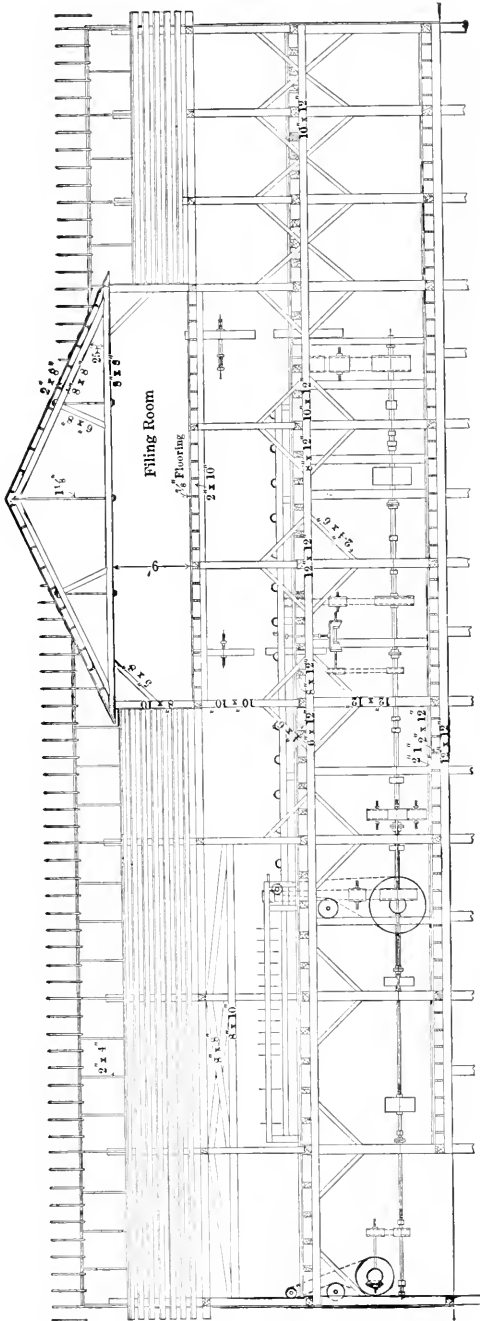

FIG. 10.—A Side Elevation of a Sawmill Building equipped with a Single-cutting Band Head-saw and a Vertical Resaw.

of 20,000 board feet or more, however, are two-storied, and it is necessary to elevate the logs in order to place them on the deck. The total lift may vary from 10 to 50 feet. The great variety of conditions which may be encountered, due to character of storage, topography, and daily log requirements of the mill, have led to the development of a number of different hoisting devices designed to meet specific needs.

Logs, except at portable or semi-portable plants, enter the end of the sawmill nearest the head-saw in a direction parallel to the travel of the carriage. In mills having a single head-saw, the logs enter on the right-hand side of the building of a left-hand mill, and vice versa.<sup>1</sup> When a mill has two head-saws, the logs enter at the center of the mill building, between the two log decks. Mills having more than two head-saws may have two log-elevating devices.



*Photograph by A. E. Moss.*

FIG. 11.—A Portable Sawmill Plant cutting Second-growth Hardwoods. Note the Method of Log Storage.

### From Land Storage.

*Skids.*—At portable and semi-portable sawmill plants, the facilities usually provided for bringing logs into the mill are two or three large skids, placed at right angles to the carriage and sloping gently towards it (Fig. 11). The skids extend away from the carriage for a sufficient distance to furnish storage for such logs as are normally carried on hand. These skids correspond to the deck in a large sawmill. The logs, when brought from the woods, are unloaded directly upon this

<sup>1</sup> A right-hand sawmill is one in which the head-saw is at the right hand of a person standing on the log deck, facing the saw.

deck. Workmen roll them upon the head blocks of the carriage, which are slightly below the level of the top of the deck. The gap between the outer end of the head blocks and the deck is spanned by short movable skids which prevent the logs from dropping down between the carriage and the deck.

*Rollway and Buggy.*—This type of elevating device is used where logs are stored on rollways.<sup>1</sup>

A narrow-gauge track, having a slight up-grade toward the mill, is laid parallel to the rollway for its entire length. The track from the rollways is carried on a trestle up to the level of the sawing floor, on which it is laid parallel to the log deck. A power-driven hoisting

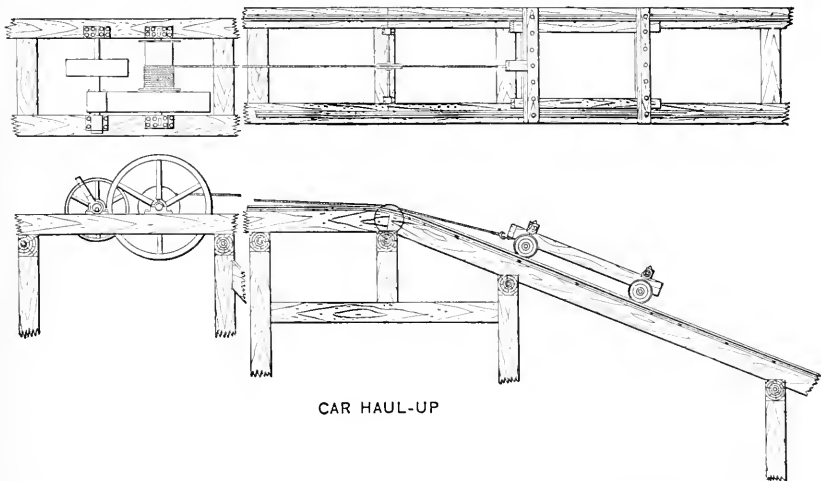

*By permission Hill-Curtis Co.*

FIG. 12.—Side and Top Elevation of a Car Haul-up used at Plants which have Dry Storage for Logs.

drum is placed at the far end of the track and this holds sufficient chain or  $\frac{5}{8}$ -inch wire rope to reach to the far end of the rollway.

The logs are loaded on a small four-wheeled truck or "buggy," which is pulled into the mill by means of the cable attached to the forward end of the truck.<sup>2</sup> The truck frame is made from heavy timbers with a bunk over each set of wheels. The bunks are spaced about 8 feet apart and have projecting spikes on their upper face to hold the logs in place. The capacity of a truck is from one to two logs. The deck man pushes the truck out of the mill and as it descends the incline, the cable is unreeled from the drum. Sufficient momentum must be acquired to carry the truck to the far end of the rollway, the car being stopped by means of a friction brake on the drum.

<sup>1</sup> See page 12.

<sup>2</sup> See Fig. 12.

When the truck has been "spotted" at a point where the desired logs are located, the chock block, holding the logs on the rollway, is removed, and the logs are rolled on to the truck by means of peavies or cant hooks. This is a common method at small hardwood mills, but its capacity is limited to a mill of from 20,000 to 25,000 board feet daily output. Ten horsepower is usually sufficient for its operation, although the power required is dependent on the size and number of logs handled at one time; on the condition of the truck and the track; and on the amount of the vertical lift.

*Endless Chain and Jacker.*—Logs stored on rollways are sometimes brought to a jack chain<sup>1</sup> at the foot of the incline leading into the sawmill by an endless chain to which dogs are attached at 6- or 8-foot intervals. This chain travels in a trough parallel to, and for the full length of the rollway, and slightly below it. The logs are rolled upon the endless chain by the rollway man and are carried to the foot of the incline at a speed of about 80 linear feet per minute.

*Rollway and Canal.*—Canals from 4 to 20 feet wide and several feet deep are occasionally substituted for the endless chain or for the truck previously described. The logs are dumped into the canal and poled to the foot of the jack ladder. The advantages claimed for this system are that the dirt is washed from the logs and that it is possible to assort them. The water for the canal is pumped into it as needed. This system has been used, to a limited extent, both at hardwood and at softwood plants.

*Derrick.*—At some mills where both softwoods and hardwoods are handled, the former are stored in a log pond and are taken into the mill by a jack chain, while the latter, because they will not float, are lifted directly from the log cars by means of a derrick and deposited on the jack chain which carries the softwoods into the mill. One such device, installed in a southern softwood and hardwood mill, can handle 600 logs daily.<sup>2</sup>

*Overhead Cableway.*—Devices of this character used for assorting and storing logs and, in some cases, for delivering them to the log deck, are described on pages 13 and 14. The overhead cableway system also has been used to transport logs from a storage yard on one side of a stream to the sawmill on the opposite side. A platform equipped with skids is built out from the sawmill deck. The span of the overhead system crosses this platform, and the logs, as they are brought to the mill, are dropped on the skids and rolled upon the deck as needed. When logs are not required immediately for manufacture, they may be assorted and stored in piles underneath the main cable.

<sup>1</sup> For a description of the jack chain, see page 30.

<sup>2</sup> Described in *American Lumberman*, April 2, 1910.



*Log Car to Sawmill Deck.*—Mills having a single-band head-saw sometimes dispense with storage yards or ponds. The loaded log cars are hauled into the mill, Fig. 13, and the logs unloaded directly upon the log deck.<sup>1</sup> This requires storage tracks within reach of the mill, both for loaded and for empty cars, and also an inclined track leading into the mill, which connects with both storage tracks.

A powerful hoisting drum, which holds sufficient cable or chain to reach to the farthest point at which loaded or empty cars may be placed, is installed at the far end of the log deck.

The cable is fastened by means of a link pin to the drawhead of the nearest loaded car, and the whole train moved forward to a point near



FIG. 13.—A Loaded Log Car going up the Incline leading to the Sawing Floor. A Method used at some Plants which do not have Log-storage Facilities.

the foot of the incline. The forward car is then uncoupled from the remainder of the train and pulled into the mill by the side of the log deck, the outer rail of the track in the mill usually being elevated about 12 inches to facilitate unloading. After the logs are placed on the deck, the car is allowed to drop down the incline (the track in the mill has a slight down-grade toward the head of the mill, so that the car can be moved easily), and on reaching the base it is switched on to a siding for empty cars. The cable is then detached and carried to the foremost loaded car, and the process is repeated.

This system requires two sets of log cars, one at the mill and the other in the woods. It is a feasible scheme both at hardwood and softwood plants where pond facilities cannot be secured at a reason-

<sup>1</sup> See page 42.

able cost and where the maximum daily capacity of the mill does not exceed 50,000 feet, log scale.

### From Water Storage.

*Jack Chain.*—This is the most common method of elevating small or medium-sized logs into the mill from water storage. It is not generally used for very large logs, because of the heavy equipment which would be required, nor is it adapted for use at plants located along streams on which there may be wide differences in the water level, because of the difficulty or impossibility of making repairs, should a break in the chain occur during high water.

This system has an inclined V-shaped trough, known as the log haul-up; an endless chain with log dogs attached at intervals of from 6 to 12 feet; and a power-driven log jack, placed at the far end of the log deck, which drives the endless chain.

The inclined trough usually built of timbers, but sometimes of sheet steel, or structural steel and concrete, is supported on a wood, steel, or concrete trestle which also has a walk or runway for workmen along one side. The trough has a depression in the center so that the base of the log dogs and the endless chain which moves them will be below the level of the main trough. This keeps the log dogs in an upright position and furnishes a flat base on which they travel. There is severe wear on the trough where the endless chain comes in contact with it, and in some instances repair work has been facilitated by lining this portion with hickory blocks which can be easily replaced. The lower end of the incline or trough is placed at a depth below low-water mark, which will always permit logs to be floated to the base of the jack chain without interference with the idler over which the endless chain passes. The trough usually is hinged from 8 to 10 feet from the lower end, in order that it may be raised when it is necessary to repair either the endless chain or the idler. Power for elevating the end of the trough is provided by a hand-operated geared windlass which is supported on a frame-work erected over the end of the trough. This framework also supports a roof which affords shelter to the man feeding the jack chain. The upper end of the incline enters the mill on a level with, and parallel to, the log deck, so that logs can be easily rolled or thrown out of the trough and upon the log deck.

The grade of the incline is governed by the height of the sawing floor above the ground level and the distance from the head of the mill to the water's edge. As a general rule, the pitch does not exceed from 25 to 30 per cent, although occasionally it is as high as 45 per cent.

A stop, or bumper, is placed in the trough near the log jack, in

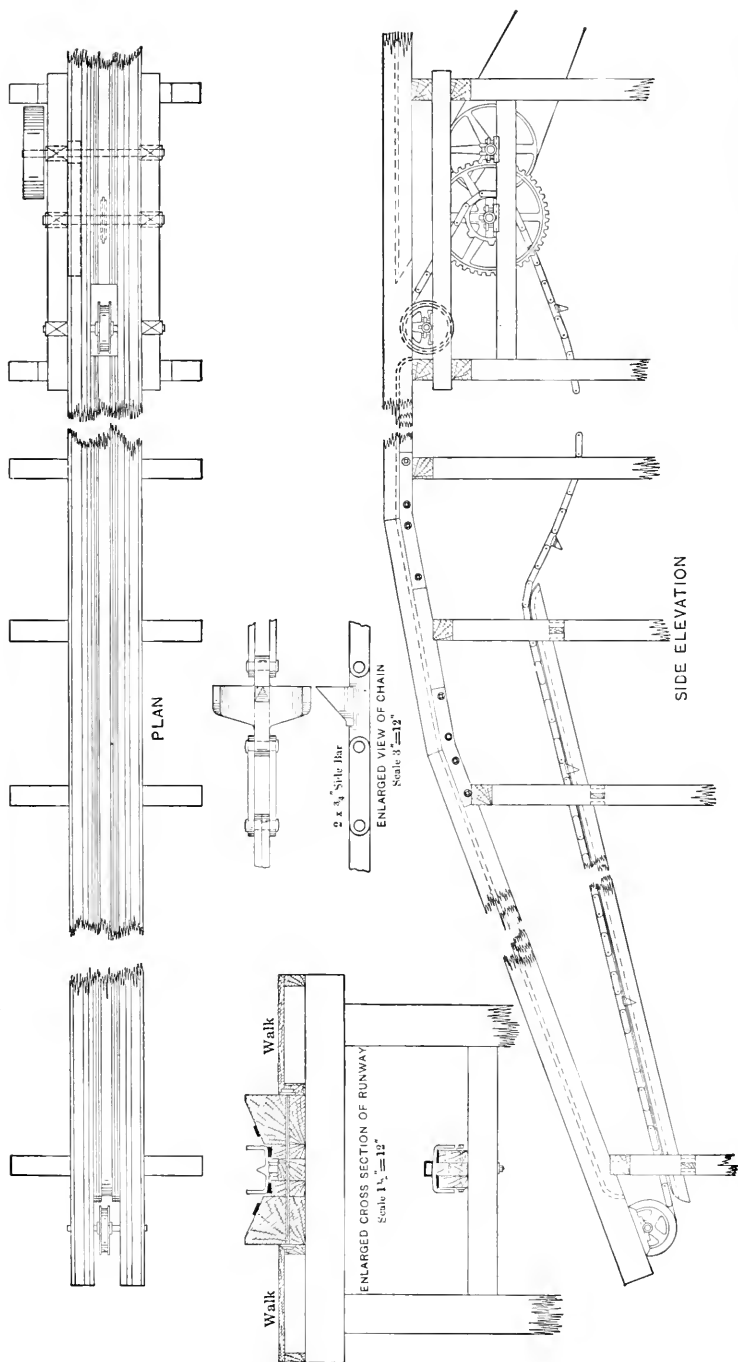

*By permission Jeffrey Manufacturing Co.*

FIG. 14.—A Plan of a Standard Log Haul-up.

order to throw off the power and stop the chain in case a log is not thrown upon the deck before it reaches the end of the trough. The power driving the chain can be thrown on or off by means of a lever, at the head of the deck, which is under the control of the deck man.

The dimensions of the trough conform to the size of the logs handled, the width of the base, inside measurement, often being from 12 to 15 inches. The sides slope outward at an angle of from 45 to 60°. A standard type of the log haul-up is shown in Fig. 14.

The endless chain may be of the flat-link or the round-link type, the former being made from steel bars from  $\frac{1}{2}$  to  $\frac{5}{8}$  inch in thickness, while the latter is made from 1- or  $1\frac{1}{8}$ -inch steel, each link measuring over-all from 9 to  $9\frac{1}{4}$  inches. The log dogs, attached to these chains, are of many types and sizes, two common forms being shown in Fig. 15.

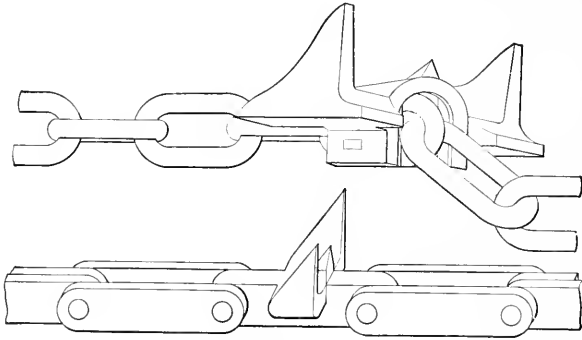

FIG. 15.—Two Types of Jack Chains and Log Dogs used in elevating Logs from Water Storage to the Sawing Floor of a Sawmill. Round-link Chain (upper) and Flat-link Chain (lower).

They are designed so that they can be replaced readily in case they become broken or worn. The chains travel over an idler at the lower end of the trough and sometimes over an idler, or "knuckle," at the point where the chain leaves the trough and feeds on to the log jack.

Log jacks are either single-gearred or double-gearred, and are arranged either for friction drive or for straight belt drive, with tightener pulley for throwing the power on or off. They require from 25 to 40 horsepower to drive them. A single-gearred jack has a main gear wheel attached to a shaft, which also bears a sprocket for driving the endless chain. The main gear wheel is driven by a pinion mounted on the same shaft as the driven pulley, which is actuated by a friction or by a belt. The speed of the chain varies from 50 linear feet per minute when large long logs are being handled, to 100 linear feet when small logs are handled. The average speed in medium-sized logs is about 80 linear

feet per minute. A standard log jacker will deliver from 800 to 1000 medium-sized standard-length logs upon the deck in a ten-hour shift.

Straight, well-trimmed logs of average size can be handled easily by a device of this character. Forked and very crooked logs, and those which are of such large diameter that they do not come into contact with the dogs, cause trouble by slipping back when they are passing up the incline. Under these circumstances the log is gripped by a pair of tongs to which a short chain is attached, the hook on the fore end of the chain being caught into a link of the endless chain.

*Bull Chain.*—A heavy endless chain is used to bring large logs into some mills. It is similar to the jack chain, with the exception that log dogs are not attached to it. The V-shaped trough is replaced by a planked incline several feet wide, up which the logs are dragged. A dog on one end of a short chain is driven into the log, and a hook on the other end of the chain is caught into a link in the bull chain, and the log is dragged into the mill. When the logs are alongside the deck, the short chains are removed and are thrown into a trough, which carries them by gravity to the foot of the bull chain. This method of elevating logs into a mill is not common and has been observed only at mills having one head-saw.

*Drag Car.*—This is a small, heavy carriage, having a frame about 3 feet square equipped with four small flanged wheels which run on a narrow-gauge track. The incline on which this track is laid is from 5 to 6 feet wide and is covered with flat iron to prevent undue wear, and to enable the logs to slip easily. The car is drawn up and lowered down the incline by means of a wire cable or a chain which is wound upon a power-driven drum at the far end of the log deck. Two or three rings are attached to the back end of the drag-car frame, and into each of these rings is caught a hook on the end of a chain, to which the logs are attached by means of a log dog. Two or three logs are dragged, side by side, up the incline and into the mill; there the chains are removed and loaded upon the drag car, which is returned to the foot of the incline. The speed of the car down the incline is regulated by a friction brake on the drum. The use of the drag car has been observed at mills of limited capacity in the Appalachian region.

*Single Log Chain.*—In some small mills where the log deck is only a few feet above the pond level, a single chain is used, to which the log is attached by means of dogs. The log is dragged up the incline by the chain which is wound on a power-driven drum at the far end of the log deck. The chain is returned to the foot of the incline by man power. This system is adapted only for mills of limited capacity, handling large logs.

*Log Buggy.*—Along rivers where there is a marked change in water level it is often found inadvisable to use an endless chain system for elevating logs into the mill, because, if a break occurs in the chain during flood time, the lower part of the incline cannot be reached for repairs until the flood waters subside. The lower end of an endless chain system also may become covered with silt, which would interfere with its operation.

To overcome these objections, the logs are elevated to the sawing floor on buggies or cars which are drawn up the incline by cables passing around power-driven drums located on the sawing floor of the sawmill. The incline is a trestle structure, extending from the sawing floor of the mill to a point below low-water mark, on which steel rails are laid, the track having a gauge of 60 inches or more. The pitch of the incline is rather steep, owing to the sharp rise of the stream banks, and a 45° slope is not unusual.

The “buggies” observed at one Ohio River operation had a framework 5 by 14 feet in size, made of 6- by 12-inch oak timbers. The framework was supported on three sets of trucks, a spiked bunk 8 feet in length being placed over the forward and rear sets. The framework was loaded with old iron in order that the buggy would submerge on reaching the water level.

The cable used for pulling the logs into the mill was  $\frac{5}{8}$  inch in diameter and was reeled on to a drum 18 inches in diameter and 60 inches long, the latter being driven by a friction device.

In operation, the car was lowered down the incline and submerged to a depth which would permit logs to be floated over the bunks. When the car was pulled up the incline the logs settled down on the bunks and were carried into the mill, where they were rolled off upon the deck. This system can be adjusted to any water stage, and if, through breakage of the cable, the car is lost, it can either be recovered or quickly replaced. A similar system has been used at some of the redwood mills in northern California.

*Log Lift.*—This type of elevating device represents a radical departure from those previously mentioned and is coming into common use in the Northwest, especially along Puget Sound, the Columbia River and other deep waters, because of its cheaper construction and up-keep as compared to the endless-chain system. Also, the mill may be placed close to the shore line without the necessity of having an incline projecting out from the mill into deep water.

The chief features are shown in Fig. 16. There are several cables or chains, usually the former, fastened at one end to the log deck at intervals of 8 feet; the other ends are fixed to hoisting drums located overhead, the cables being long enough to allow the loops to fall below

the surface of the water in the canal, to a depth which will permit logs to be floated over them. The overhead drums, rotated by a friction drive, wind up the cable and thus elevate the logs to the deck. The lift varies from 10 to 35 feet, and the hoisting speed is about 40 feet vertical, per minute.

A log lift with a worm-gear drive run by a reversible motor was put on the market in 1919. The advantage claimed for it is that a brake is not required, since the load cannot be moved except by the application of power to the worm.<sup>1</sup>

A log lift will handle small logs as well as large ones, the maximum requirements seldom being for logs greater than from 4000 to 5000 feet, log scale. The average load does not exceed from 1200 to 1500 feet, log scale. The power required to operate a device of this character varies from 37 to 52 horsepower, depending on the size of the logs handled.<sup>2</sup>

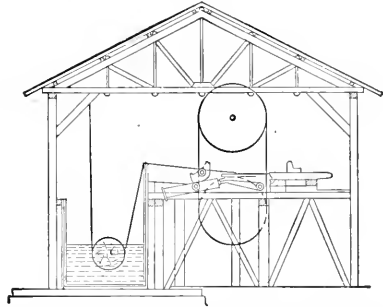

FIG. 16.—End Elevation of a Sawmill Building showing a Log Lift, Sawmill Deck, Band Head-saw, and the Carriage.

## REMOVAL OF GRIT FROM LOGS BY WASHING

Operators who store logs, either in water or on land, sometimes wash them to remove gritty material which may have collected in the bark or in season checks.

A common practice is to install one or more feed water pipes at some point along the jack chain, and to thoroughly drench the sides and top of the logs, as they pass up the incline into the mill, by means of small spray pipes attached to the feed pipe, Fig. 17. This method is not wholly adequate, since the underside of a log is not washed.

An objection to this scheme is that it requires a large volume of water, which must be pumped either directly into the pipes or else into a storage tank from which the necessary supply and pressure may be secured.<sup>3</sup>

<sup>1</sup> See *The Timberman*, Portland, Ore., September, 1919, page 36.

<sup>2</sup> See *Electricity in the Lumber Industry*, by E. F. Whitney. *Proceedings of American Institute of Electrical Engineers*, Vol. XXXIII, No. 12, 1914, page 1838.

<sup>3</sup> For a mechanical method of securing similar results, see "rock saw," page 97.

## DEVICES FOR CROSS-CUTTING LOGS

It is the practice in some regions, especially where power skidding is in vogue, to bring long logs to the mill and to cut them into shorter lengths before sawing. This may be done either before the logs enter the mill or while they are in the log trough on the sawing floor of the mill.

There are several advantages in bringing long logs to the plant. Power logging is cheaper, per thousand feet, for long logs than for short ones; the division of the bole at the mill reduces the amount of log bucking in the woods; more experienced help can be employed to cut the logs in the most economical manner, as far as quality is concerned; the stock of lumber can be kept more nearly to a normal assortment



FIG. 17.—Log-washing Equipment installed on a Jack Ladder.

of lengths than where short logs are cut in the woods, many weeks in advance of manufacture; special stock may be secured at once without waiting for the timber to be cut in the forest; and when logs are towed to destination, long logs can be rafted to better advantage than short ones.

The merchantable portion of the bole, in timber such as southern yellow pine, often is cut into two sections in the forest, while the large West Coast timber is cut into lengths running from 24 to 40 feet.

Large and crooked logs can be handled more readily in the water than on the mill deck, and therefore mills which have large timber often prefer to cross-cut their logs before they reach the mill deck.

Three types of saws are used for cross-cutting purposes, namely, the drag-saw, the circular cut-off saw, and the endless-chain saw. A drag-saw has a blade 6 feet or more in length, and from 10 to 12 inches in width, attached either to one arm of a walking-beam or to



the piston of a steam or compressed-air cylinder. The mechanism for a steam or compressed-air cylinder is mounted on a frame and so adjusted that the cylinder, with saw attached, can be moved through a vertical arc of a circle, either by a system of cables and weights or by a steam cylinder, in order that the height of the cutting blade can be accommodated to logs of varying diameters, and can also follow the cut as it progresses from the top to the bottom of the log.

### Marine Drag-saws.

When the logs are cross-cut while still in water storage, the saw is mounted on a pontoon along which the logs are floated. An auxiliary cross-cutting saw is sometimes installed on the sawing floor of the mill for handling "sinkers."

The log-cutting equipment used at certain mills along the Ohio River, where logs are rafted to the mill, comprises a float 40 feet long and 12 feet wide, upon which an electrically-driven drag-saw is mounted. A shelter built over the raft is used for housing the machinery and for the protection of workmen in inclement weather. This float is anchored near shore, between the rafts of logs and the incline. As the log rafts are broken up, the logs pass alongside the float, and are made fast by the attendant. The device used for holding the logs against the float consists of a chain, to one end of which is fastened a handle about 4 feet long. The other end of the chain is attached to the float, near the drag-saw. By means of the handle, the chain is held in the form of a loop over which the logs are floated. The chain is then drawn tight to hold the log against the float, and is made fast by catching a link into a metal slot. The logs, after being cross-cut, are poled to the foot of the nearby incline and are then taken into the mill. Sinkers often cause trouble when they are bucked in the water; therefore, they are cross-cut on the log deck. When they are cross-cut in the water, it is necessary to buoy them up with pontoons until they reach the foot of the elevating device.

Another type of marine drag-saw used at some plants is shown in Fig. 18. In this type, the equipment is mounted on a float, moored near the foot of the incline. Power for driving the saw is derived from the steam cylinder *A*. The latter is supported on trunnions at *B*, so that the saw may be raised or lowered by means of the pulleys and weight shown in the diagram. The logs are held firmly against the float by the vertical dogging arm *C*, the base of which can be moved away from or toward the float by the piston in the cylinder *D*. Spikes on the end of the dogging arm *C* prevent the log from slipping while it is being sawed.

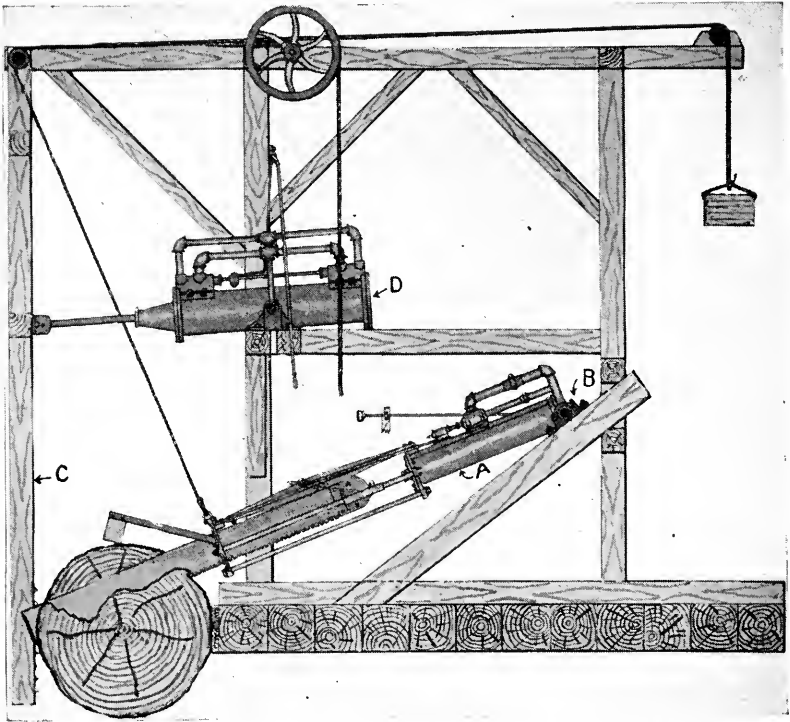

*By permission Hill-Curtis Co.*

FIG. 18.—A Marine Drag Saw. A. Cylinder driving the Drag Saw. B. Trunnion. C. Dogging Arm. D. Cylinder for moving the Dogging Arm.

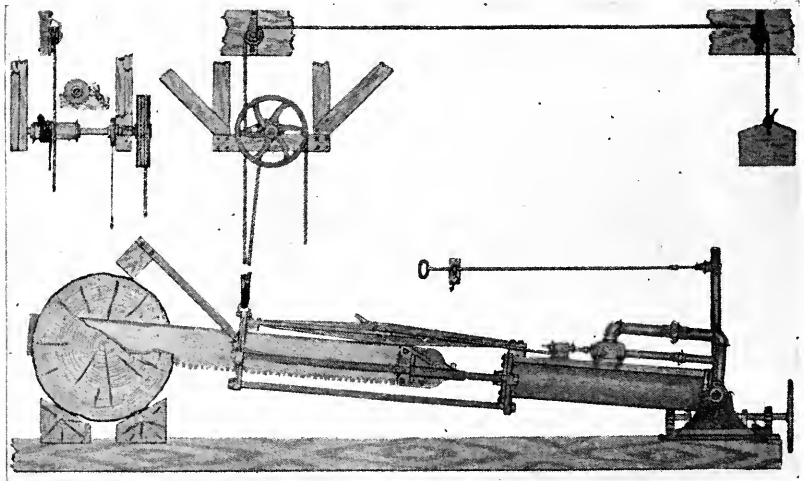

*By Permission Hill-Curtis Co.*

FIG. 19.—Steam-driven Drag Saw for Deck Use.

### Deck Drag-saw.

This type of saw has steam, compressed-air, belt or walking-beam drive. The equipment is placed on the deck near the point where the logs enter the mill, and the saw extends across the log trough. A type of steam drive for deck use is shown in Fig. 19. This does not differ in the essential features of construction or operation from the marine steam drag-saw shown in Fig. 18. A steam or a compressed-air drive usually gives a more even stroke than the other types mentioned.

The walking-beam drive for a drag-saw with double cranks, driven either by spur or bevel frictions, is shown in Fig. 20. The beam *A*,

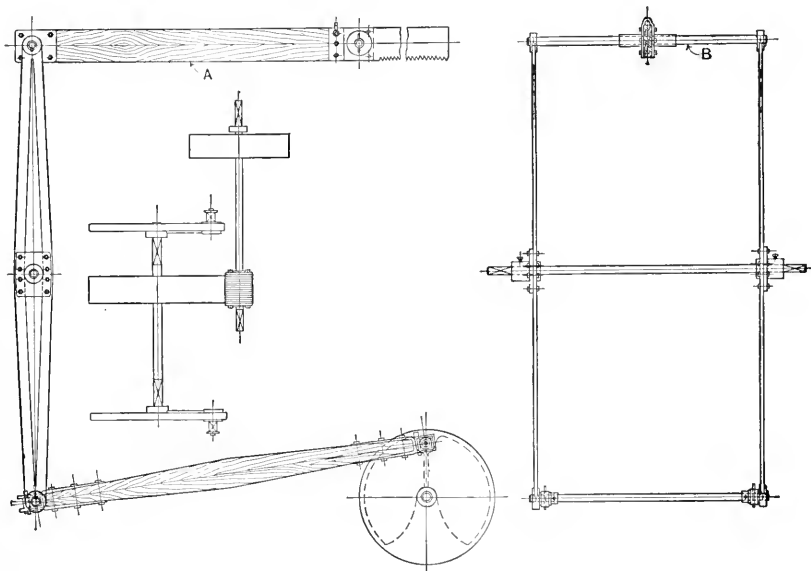

*By permission The Prescott Co.*

FIG. 20.—A Deck Drag Saw driven by a Walking-beam. The Arm *A* projects above the Level of the Log Trough and the Remainder of the Drive is underneath the Sawing Floor of the Mill. Arm *A* may be shifted along the Shaft *B* in order that the Cut may be made at the Desired Point.

actuating the saw, projects above the floor of the mill, but the driving equipment is located under the floor of the mill. The sawing arm has a side movement of 5 feet along the shaft *B*, to accommodate logs that cannot be stopped at a precise spot.

### Circular Cut-off Saw.

Circular cut-off saws are now in use in many mills which handle medium-sized logs. They are more rapid in action than drag-saws

but are not adapted for very large logs because the diameter of the saw is rarely more than 72 inches.<sup>1</sup> This confines their use to logs of a maximum diameter of approximately 32 inches.

The circular cut-off saw shown in Fig. 21 has a long lever arm *A*, pivoted at *B*, carrying the saw on one end and a weight on the other. The arm can be raised or lowered by means of the piston rod *C*. The post *D* serves as a stop and support for the arm *A*. In some types, the

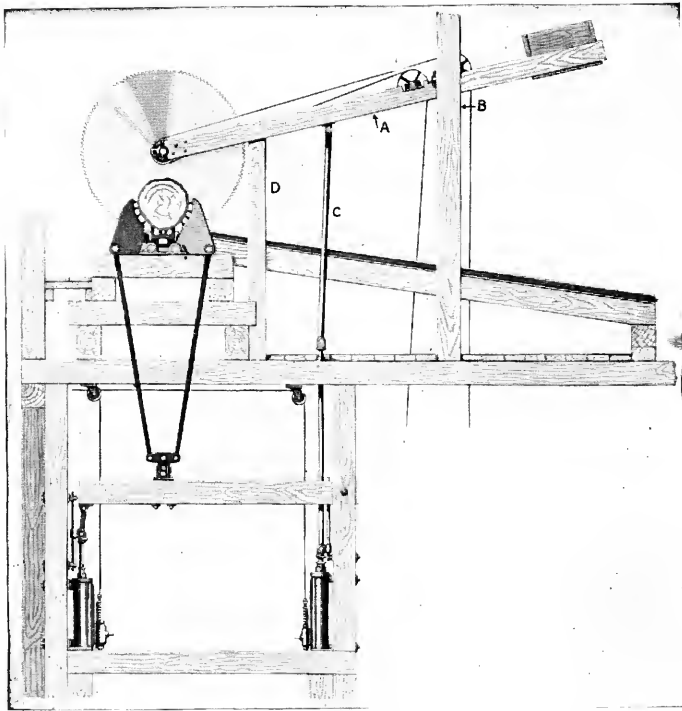

*By permission Allis-Chalmers Mfg. Co.*

FIG. 21.—A Circular Cut-off Saw for Deck Use. *A*. Lever Arm. *B*. Supporting Post. *C*. Control Rod. *D*. Stop and Support for Lever Arm. Note the Type of Log Dogs and Method of Control.

piston control is replaced by a rope hanging from the arm between the fulcrum and the saw, by means of which the latter can be lowered by the deck man. The balance is so adjusted that, as soon as the deck man releases his hold on the rope, the arm automatically rises and elevates the saw above the log trough, where it is out of the way.

A 30-horsepower motor will drive a 72-inch cut-off saw.

<sup>1</sup> An inserted-tooth cut-off saw 108 inches in diameter was installed in a Washington shingle mill, early in 1920. This is the largest circular saw ever used for any purpose.

### Endless-chain Saw.

This type of cut-off saw is occasionally used in sawmills. It has an endless chain in which the links, represented by saw teeth shaped like those of a cross-cut saw, are riveted together. The back of the teeth fit into sprockets, the chain being supported by a steel arm 6 feet or more in length, one end of which is pivoted to the frame carrying the driving power. The chain passes over a driving sprocket at the fixed end and over a blank sprocket at the opposite end. The outer end of the arm sometimes slides up and down along an arc, the arm being raised and lowered by means of a cable attached to the outer end. This cable passes through overhead blocks and has a balance weight suspended from the free end. Power for driving the chain is usually furnished by an electric motor of 15 horsepower.

### Band Cut-off Saw.

A band mill of special design, with small-diameter wheels and using a narrow blade, is manufactured for cross-cutting purposes. It is sometimes used at pulp mills, but rarely at sawmills.

### Log Dogs.

It is necessary to have some device for holding a log rigid while it is cross-cut into two or more sections. Several patterns of log dogs are used for this purpose. These are installed in the log trough at the point where the cut is made.

The type shown in Fig. 22 will hold logs ranging in diameter from 6 to 48 inches. There may be one pair of jaws, or two pairs which grip the log on either side of the saw-cut.

The lever arms actuating the jaws are operated by the piston of the cylinder. The deck man, by pressing on the lever A, opens the valve at the base of the cylinder, which forces the piston

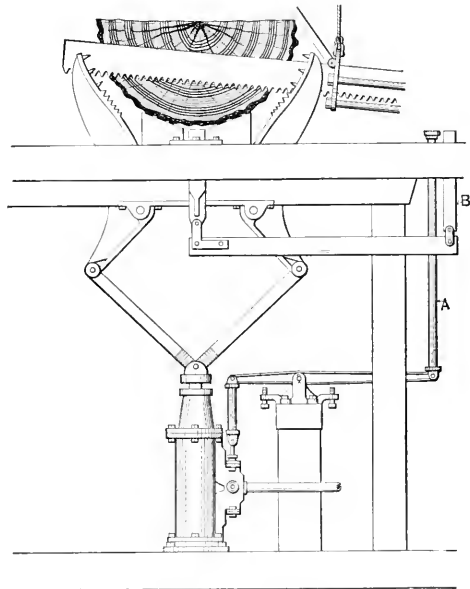

*By permission Hill-Curtis Co.*

FIG. 22.—A Dog for holding Logs when they are cross-cut on the Deck.

and arms upward and thus causes the jaws to close on the log. When the foot pedal is released, the pressure of steam on the upper face of the piston forces it downward and causes the jaws to open. The lever *B* is one of a series of stops for measuring log lengths. It is not always a part of the equipment.

Another type is shown in Fig. 23. The frame is set in the log trough below the level of the jack chain. The two jaws work in planed ways

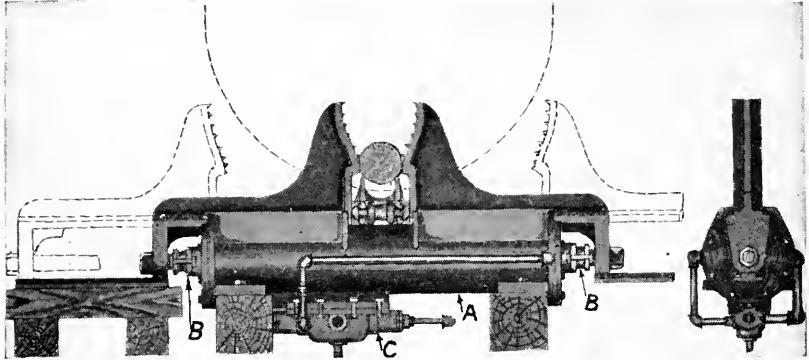

*By permission Hill-Curtis Co.*

FIG. 23.—Log Dogs used to hold Logs when they are cross-cut on the Log Deck.

A. Steam Cylinder. B. Piston Rods operating the Jaws. C. Cylinder Valve.

on the top side of the cylinder *A*, and are attached directly to the piston rods *B*, which extend from each end of the cylinder. Although the two pistons are separate, they are both controlled by a single valve *C*, which is operated by the deck man, either by foot pedal or by lever control. This pattern is built in several sizes, the largest handling logs 5 feet or less in diameter.

## THE LOG DECK AND DECK MACHINERY<sup>1</sup>

### Log Deck.

The log deck, which is used to store logs until they are required for sawing, is located at the end of the mill where the logs enter. Machinery is installed on the deck to throw logs from the log trough on to the deck, to hold them there until needed and then to aid in loading and turning them on the carriage. Log decks vary in size according to the length of logs handled. A deck for the ordinary run of logs is from 24 to 40 feet in length and from 16 to 20 feet in width, with a slope from the log trough toward the carriage of from 12 to

<sup>1</sup> See Fig. 24, for the relative location of equipment on the sawing floor of a sawmill.

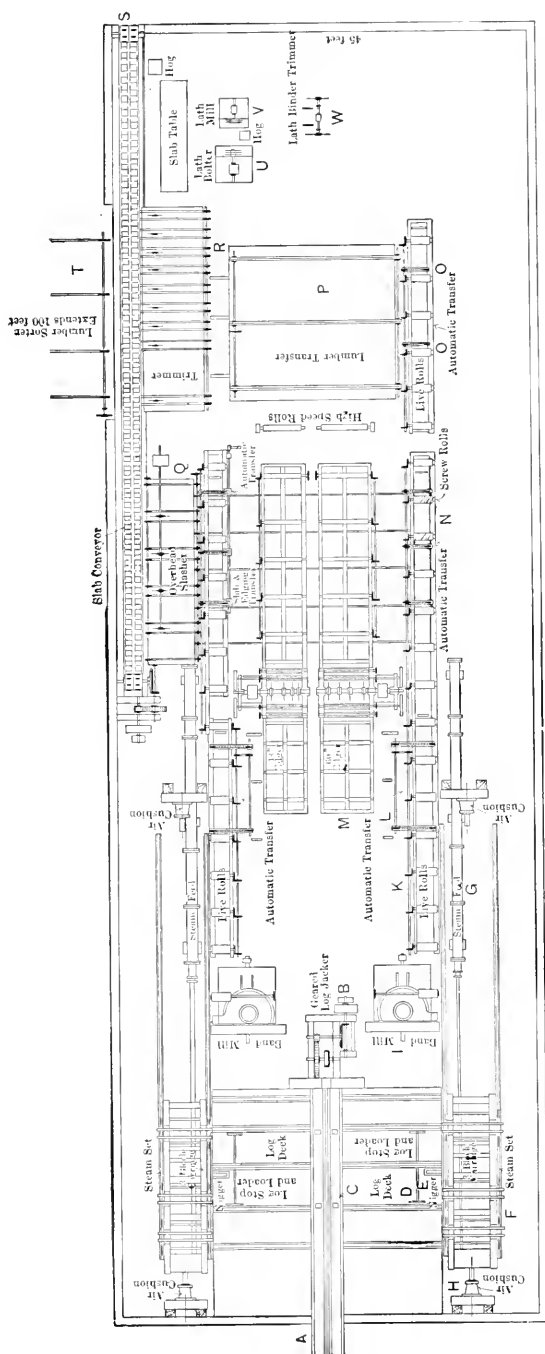

By permission The Prescott Co.

FIG. 24.—The Sawing Floor Plan of a Sawmill equipped with two Single-cutting Band Head-saws. A. Log Trough. B. Geared Log Jacker. C. Log Deck. D. Log-stop and Loader. E. Steam Nigger. F. Carriage. G. Steam Feed Cylinder. H. Bumper. I. Band Mill. K. Live Rollers from the Head-saw to the Rear of the Sawmill. L. Lumber transfer to Edgers. M. Edger Table. N. Screw Rollers for dumping Slabs. O. Automatic Transfer from Live Rollers to Transfer to the Trimmer. P. Q. Slasher. R. Trimmer. S. Slab and Refuse Conveyor. T. Assorting Table. U. Lath Bolter. V. Lath Mill. W. Lath Binder and Trimmers.

15°. Too low a pitch necessitates the constant service of a cant-hook man on the deck, while a pitch which is too steep tends to cause the logs to jump the log stop at the foot of the deck.

The framework of the deck is made of heavy timbers which are usually floored with plank. The top of the deck is shod with sections of railroad iron, placed about 6 feet apart and at right angles to the log trough. When long logs are handled, the length of the deck must be increased, since it must be slightly longer than the maximum log length, unless there is room at the front part of the mill for the logs to extend over the edge of the deck.

Fig. 25 shows a cross section of the deck of a double mill and illustrates different types of deck machinery which may be used. The machinery on the two sides usually is of the same type, that on one side being installed right-hand, that on the other, left-hand. The storage capacity of a deck is from six to ten logs.

### Log Kicker.

Logs which are elevated into the mill by an endless chain are thrown or rolled upon the deck by means of log kickers of various types, a common form being shown in Fig. 25 at *A*. The type *B* shown in the same figure, requires less headroom on the first floor of the sawmill, but is not commonly used in standard mills.

The log kicker comprises a rock shaft *C*, placed below the log deck, to which are attached as many heavy cast-iron triangular rocker arms *D* as are necessary for handling the maximum log length. The arms are usually three in number on a deck for standard length logs; while for short logs, two arms only are required. On a two-arm log kicker, the arms are spaced 8 feet center to center, and on a three-arm machine 8 and 7 feet respectively. A shover arm *E*, which passes through a cast-iron guide on the side of the trough opposite the deck, is attached to each triangle. The shaft and the arms in turn are operated by a steam cylinder <sup>1</sup> *F*, the piston of which is attached to an arm on the rock shaft. The device is operated by a foot pedal or by a lever arm which, by means of the necessary rod connections, controls the two-way valve on the cylinder *F*. The log kicker is controlled by the deck man, who, by the use of the foot pedal or lever, admits steam into the base of the cylinder *F*, thus actuating the lever arms and forcing the log out of the trough and upon the deck. This type is best adapted for logs of average length.

A mill having two log decks has a separate log kicker equipment for each. Mills having two head-saws are usually equipped to cut

<sup>1</sup> The size of the cylinders varies from 10 by 30 inches to 18 by 42 inches, depending on the amount of work to be performed.



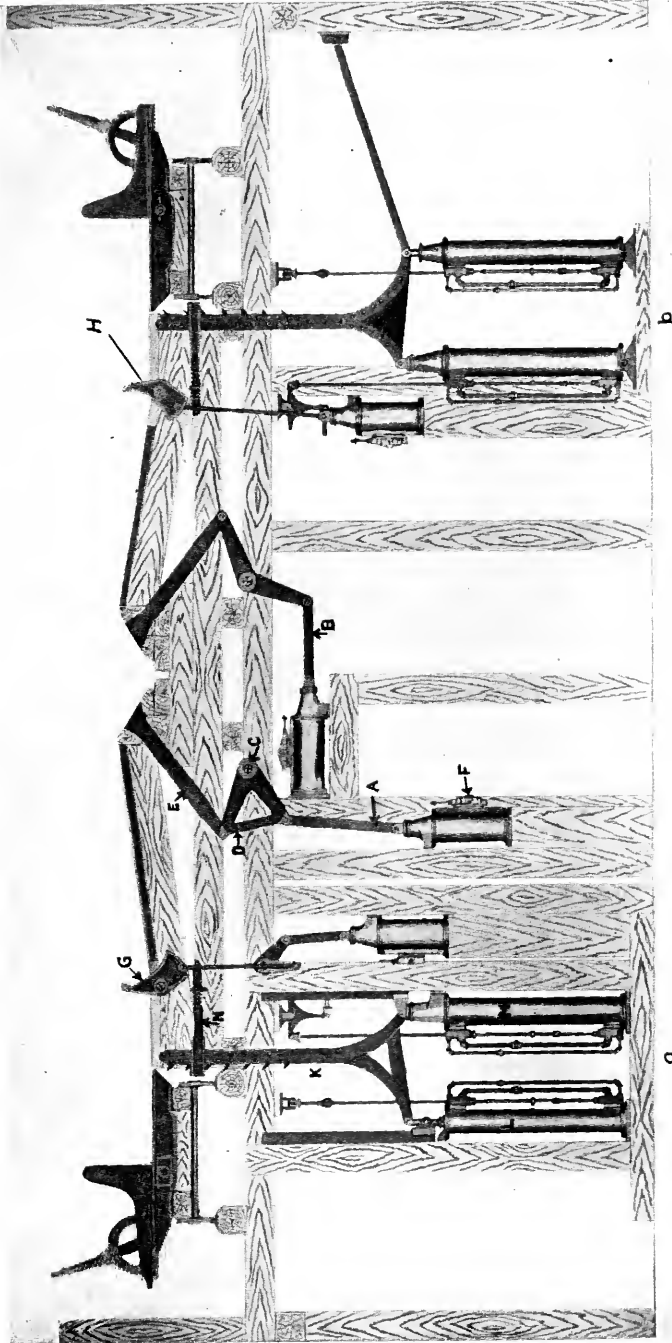

FIG. 25.—A Cross-section of a Double Sawmill Deck showing the Deck Machinery. A and B, Two Types of Log Kickers, G and H, Two Types of Log-stops and Loaders, K, Steam Nigger Bar, L and M, Steam Nigger Cylinders, N, Spring Floor Plate.

By permission Hill-Curtis Co.

the short logs on one side and the longer ones on the opposite side, in which case the short-side log kicker would have two shover arms and the long side three.

A type of log kicker designed for rolling logs both ways out of the log slide is shown in Fig. 26. The main cylinder *A* is oscillating, being tilted either to the right or to the left by the small stationary cylinder *B*. When the cylinder *A* is tilted to the right, logs are thrown to the left, and vice versa. The valves of both cylinders are controlled by

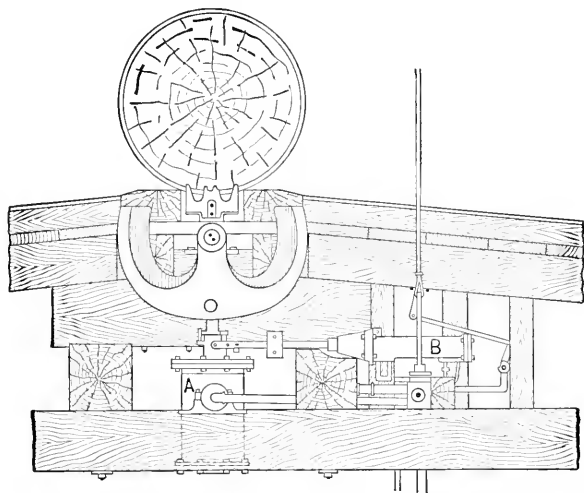

FIG. 26.—A Log-kicker which will roll Logs both to the Right and to the Left. *A*. Main Cylinder which is oscillating. *B*. Stationary Cylinder which is used to tilt *A*.

one lever. For single decks, the cylinder *B* is not required, cylinder *A* being fixed in position to roll the logs in the desired direction.

### Log Transfer.

Some decks are equipped with a log transfer which is used to crowd logs towards the log-stop and loader, thus eliminating the need for a cant-hook man on the deck. The most simple form of log transfer has two parallel lines of heavy flat-link chains spaced about 7 feet center to center, which extend crosswise of the deck from a point near the log trough to another point near the base of the deck. The chains, which are driven by sprockets attached to a common shaft to which power is applied by means of friction gears, rest on the top of skids which are raised a few inches above the deck level. The logs ride on the chains and are carried down the deck when the chains are in motion.

A second type, sometimes known as a "ducking dog" transfer, has two parallel chains, extending from the upper to the lower part of the deck, which are driven from a common shaft by a reversible friction drive. Dogs with triangular-shaped heads are mounted one on each chain, in a parallel line across the deck, the tops of the dogs projecting about 1 foot above the skids on which the logs rest. The triangular projecting heads are pivoted on the dogs, so that when the transfer is reversed and driven towards the log trough the heads will "duck" and pass under the logs. When the chains move in a direction towards the carriage, the dog heads remain upright and carry the logs down the deck.

They are useful when the pitch of the log deck is low, and also when rough or crooked logs must be forced towards the carriage.

### Log-stop and Loader.

This device, two types of which are shown in Fig. 25, *G* and *H*, is placed near the lower edge of the log deck for the purpose of holding logs on the deck until wanted, and also to throw them upon the carriage.

Type *H*, the more common one in use, has two or more curved arms, rigidly keyed to a shaft which is attached to the deck skids, parallel to the carriage track. The concave side of the arms faces toward the log trough. The log at the bottom of the deck rests against these arms, which hold it in place. The arms are placed 7 feet center to center when two arms are used, and 8 and 7 feet center to center respectively, when three arms are used. When a log is to be released, the arms are made to rotate by means of the steam cylinder, to the piston of which the lower portion of the curved arm is attached. Full steam pressure is maintained in the top of the cylinder when the log-stop is in its normal position, in order that the log, by its weight, may not cause the arm to rotate.

The sawyer controls the valve action by means of a foot pedal and connecting rods. To load a log on the carriage, steam is admitted to the base of the cylinder, and by means of the piston the base of the curved arm is thrust upward and forward, thus throwing the log toward the carriage. The next log on the deck then rolls against the concave side of the arm and has its movement arrested. The heavy base of the arm causes it to start rotating as soon as the pressure on the foot pedal is released, and the steam pressure in the top of the cylinder, acting on the piston head, brings the arm back to its original position.

The type *G*, known as the double-connected log-stop and loader, differs somewhat in principle from *H*. When at rest the log-stop is locked because it is on a dead center, the pull on the shaft being in a

vertical plane. As soon as steam pressure is applied to the base of the piston, the rod connecting with the curved arm is thrown off center and the log stop acts in the manner described for *H*. The main shaft is placed below the deck, the curved arms working on short journals.

### Log-turning Devices.

The turning of logs on the saw carriage formerly was done by manual labor, several workmen with cant hooks or peavies being required to turn a large log. As the daily capacity of sawmills increased through the use of faster sawing machinery, the hand method became obsolete, and was replaced by a power device.

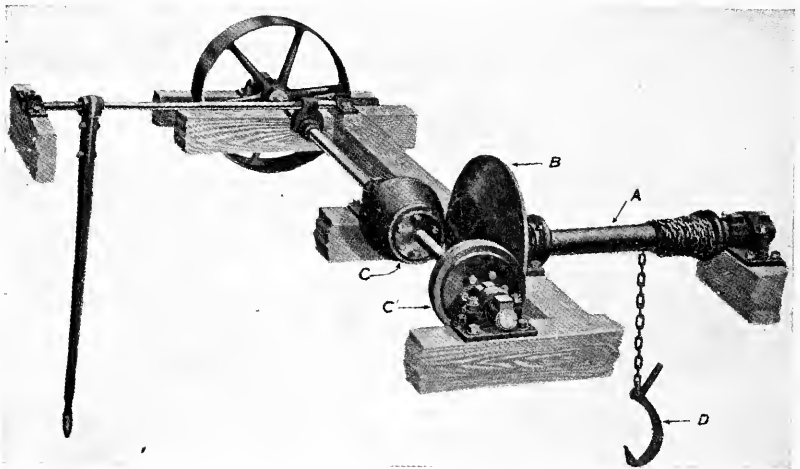

*By permission The Prescott Co.*

FIG. 27.—An Overhead Log Turner. *A*. Chain Shaft. *B*. Steel Friction Wheel. *C*. Paper-faced Friction Wheels. *D*. Canting Hook.

*Overhead Log Turner.*—Although this is one of the early types of log turners it is still used in many mills, either as auxiliary to the “steam nigger” or as the chief means of turning logs which are of large diameter or of exceptional length. It comprises a drum or shaft, Fig. 27 *A*, located over the saw carriage and parallel to it, which is driven by the steel friction wheel *B* and the two paper-faced friction wheels, *C* and *C'*, respectively, which provide for a forward and reverse motion. A chain of suitable length is attached by one end to the drum *A*, the free end carrying a canting hook *D*.

The hook and chain are lowered to the deck when the sawyer throws the log turner into gear. The chain and hook are then thrown around a log, the hook driven into it, and the chain wound up on the drum,

causing the log to rotate. The direction of rotation is controlled by the direction in which the chain is thrown around the log. This device is used not only to turn logs on the carriage but also to roll them off the deck.

*Simonson Log Turner.*—This type, shown in Fig. 28, has been devised to handle logs of large diameter such as are found in the Northwest, and it is not used in other sections of the country. The metal frame on which the cylinders and arms are mounted is placed below the deck level so that logs can be rolled over the log turner when it is

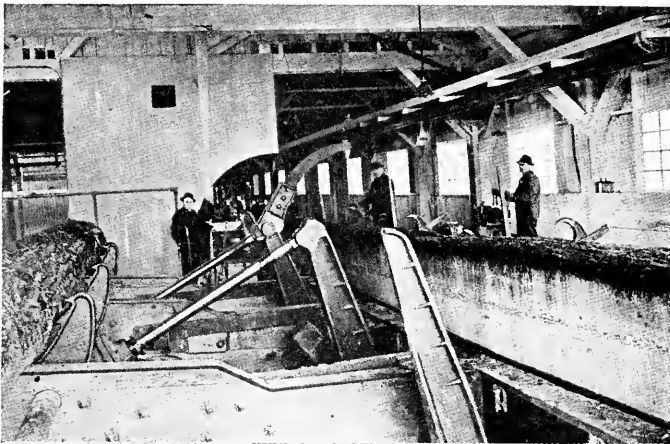

*By permission Allis-Chalmers Mfg. Co.*

FIG. 28.—A Simonson Log Turner showing the Shoving Arms, the Canting Hook, and One of the Two Cylinders which raise and lower the Arms.

not in use. Three or more shover arms, one of which has a hook attached to its upper end, are mounted on a single rock shaft. The cylinders are oscillating and serve to force the shoving arms toward the carriage or to bring them to a horizontal position under the log deck.

When a log is to be turned, the sawyer, by means of a lever control, opens the valves which admit steam into the base of the cylinders, which are then forced from a nearly horizontal position, to that shown in Fig. 28. The hook is caught on the top of the log and the latter rotated 90° toward the deck. Then the shover arms are again raised to a vertical position, and thus the log is forced back against the knees of the carriage. Log turners with more than three arms are used to handle very large or unusually long logs.

*Friction Nigger.*<sup>1</sup>—A device known as a friction nigger is often used in small mills which saw medium-sized and standard-length logs. The one shown in Fig. 29 has a toothed bar *A*, made of two heavy steel plates, and armed with steel teeth at the upper end. In turning logs, the bar is raised vertically, the teeth engage the side of the log and turn it toward the carriage knees. The teeth are so hinged that on the upward stroke they project at right angles from the toothed bar, but on the downward stroke they will turn back between the plates if they

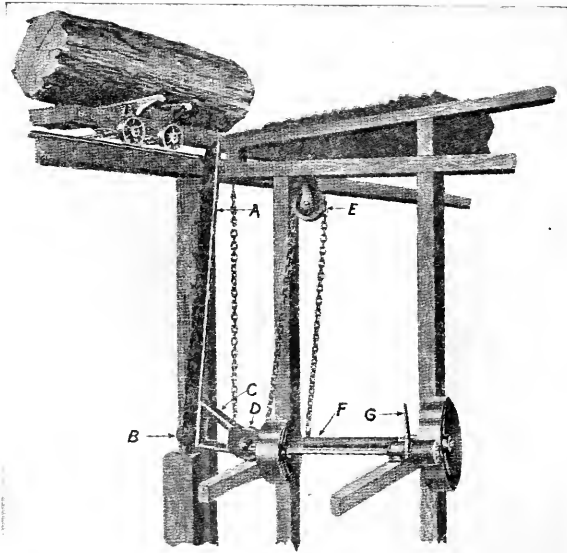

*By permission Wheland Mfg. Co.*

FIG. 29.—A Friction Nigger or Log Turner. *A.* Tooth Bar. *B.* Roller on Tooth Bar. *C.* Triangular Weight Bar on End of Tooth Bar. *D.* Pulley on Tooth Bar. *E.* Overhead Block. *F.* Chain Shaft. *G.* Control Lever.

strike an obstruction. The roller *B* travels in a guide slot which controls the upward direction of the toothed bar.

A heavy triangular steel plate *C* is attached to the toothed bar opposite the roller, and a pulley *D* is fastened to the apex of the triangle.

<sup>1</sup> The friction nigger, which was the forerunner of the present steam nigger, was first developed by Esau Tarrant of Muskegon, Mich., who, so far as known, was the first to use the toothed-bar idea for turning logs on a sawmill carriage. The present steam nigger, which was developed from Tarrant's idea, was perfected by William E. Hill of Kalamazoo, Mich., who conceived the idea of using the two steam cylinders and who also devised the single lever control.

The perfecting of the steam nigger was one of the most important innovations in sawmill machinery, because it greatly increased the speed with which logs could be handled.

The bar is raised and lowered by means of a chain, one end of which is fastened to the under side of the deck, while the other end passes around the pulley *D* over the block *E* and down to a steel shaft or drum *F* on which it is wound by means of the friction drive shown. The friction drive is thrown against the driven pulley at the right-hand side by means of the lever *G*, which is controlled by the sawyer. As soon as the power is released the raised toothed bar will resume the position shown in Fig. 29 because of the weight of *C*. The bar has primarily an upward stroke, but when it is desired to force the log back against the knee a forward stroke can be given by quickly releas-

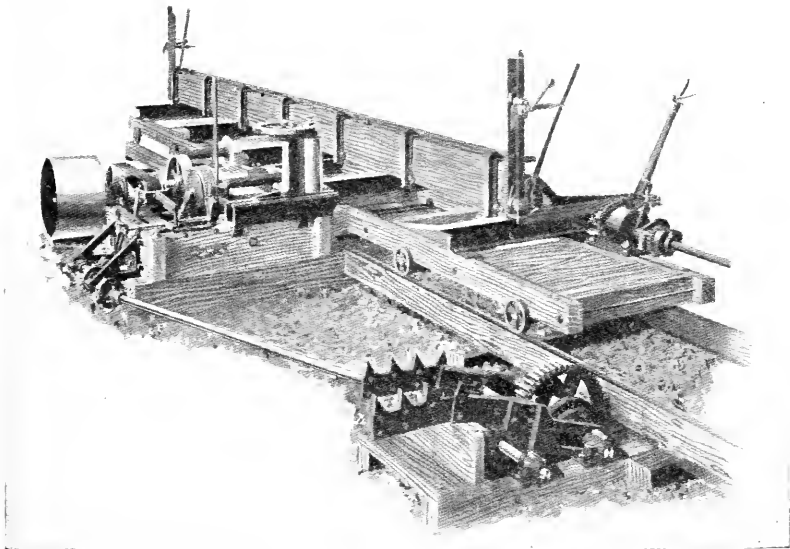

Fig. 30.—A Two-bar Log Turner for Portable Sawmill Use.

ing the power. This causes the top of the toothed bar to move toward the deck. A quick application of power again forces the bar upward and forward.

Friction niggers designed along the same general line, with wood tooth bars and fixed metal teeth often are made and installed by millwrights at small plants.

A type of log turner adapted to portable mills is shown in Fig. 30. Eccentrics and cams cause the two toothed bars to move from a horizontal to a vertical position and to work alternately up and down against the log, thus causing it to roll against the knees. The log turner is driven from the feed shaft by means of gears, which can be thrown in or out of mesh by means of a lever.

*Steam Nigger.*—This device is the form of log turner which is used in large mills for handling logs, other than those of very large diameter or of exceptional length. Two standard types are shown in Fig. 25, *a* and *b*, the first having stationary cylinders and the second oscillating cylinders.

The stationary-cylinder type has a steel toothed bar *K*, the lower arms of which are attached to the piston of the two upright cylinders *L* and *M*, which usually are about 6 feet in length, the bore of cylinder *L* being 8 inches and that of cylinder *M*, 10 inches.<sup>1</sup>

The steam nigger has three motions, vertical, forward, and backward, produced by the manipulation of the cylinders *L* and *M*. The vertical motion serves to rotate the logs toward the carriage knees; the forward stroke moves the log forward toward the carriage and drives it firmly against the knees; and the back stroke is used in forcing backward upon the deck those logs which may have accidentally passed over the log stop. A spring floor plate *N* limits the forward and backward action to approximately 18 inches, the spring taking up the shock on the back stroke. The valves on both cylinders are controlled by one lever, the lower end of which extends under the mill floor and is hung on a movable bearing. The rods connecting with the cylinder valves are attached to the lower end of the lever and at right angles to each other. When the sawyer moves the lever toward the carriage and in a direction midway between the two control rods, steam is admitted to the base of both cylinders and the nigger bar is forced upward. A forward stroke with the nigger bar can then be made by shoving the lever handle towards the log which admits steam at the base of the cylinder *L*, the steam pressure in cylinder *M* holding the nigger bar at the desired level. Pulling the lever away from the carriage reverses the process and throws the bar backwards towards the log deck.

#### THE LOG CARRIAGE AND ITS ACCESSORIES

Carriages are built for handling a wide range of log sizes and lengths. They vary from those suitable for small, short logs and bolts to those capable of handling logs of large diameter and lengths exceeding 100 feet.

The chief parts of a carriage are shown in Fig. 31 and comprise:

1. The framework *A*, usually made of timbers, but sometimes of steel, mounted on several sets of trucks which travel on a steel track laid parallel to the line of the saw cut.

<sup>1</sup> Cylinders vary in length from 4 to 6 feet and in bore from 6 and 8 inches to 12 and 14 inches, depending on the style and on the work for which they are designed.



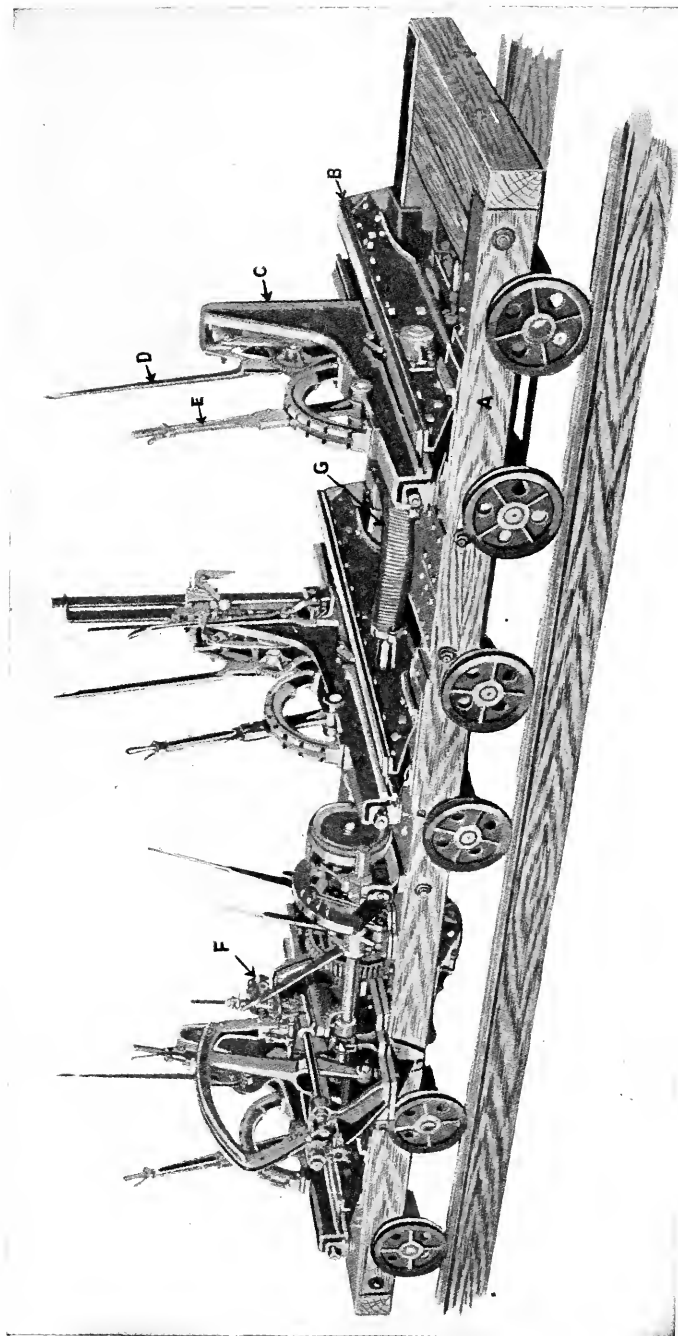

*By permission Hill-Curtis Co.*

FIG. 31.—A Three-block Carriage with Steam Set-works. A. Carriage Frame, B. Head Block, C. Knee, D. Dog Lever, E. Taper Lever, F. Set-works, G. Recceding Spring.

2. The metal head blocks which comprise a base *B*, a knee *C*, a dog lever *D*, a taper set *E*, and a rack-and-pinion or a screw gear.<sup>1</sup>
3. The carriage offset<sup>2</sup> for automatically moving the carriage body away from the saw line on the gig-back of the carriage (used only on band saw carriages).
4. The set-works *F* by means of which the knees are advanced so that the log is brought into proper sawing position; also the receding works<sup>3</sup> by means of which the knees may be moved in a direction away from the saw line.
5. The carriage drive or mechanism for propelling the carriage.

### The Framework.

A carriage usually is from 16 to 24 feet in length, with a maximum distance between the saw line and the face of the knee of from 25 to 48 inches. Carriages for large sawmills are 20 feet or more in length, and have a maximum distance between the saw line and the face of the knee of from 36 to 84 inches.

The frame body is made of timber in all but some of the largest Pacific Coast types of carriages. An extension which serves as a platform on which the carriage workmen may stand is built out from the framework of the carriage on the side opposite the log deck.

The length of carriage is made to conform to the average range of log lengths. An extension or trailing section 6 feet or more in length is provided when a longer carriage is needed, which is attached to the rear of the carriage and when not in use is left on the track alongside the log deck and next to the bumper. The extension is equipped with head-blocks and set-shaft and also with couplings by means of which it can be readily attached to and detached from the main carriage. A form of coupling for the carriage and extension is shown in Fig. 32. The set-shaft coupling *A* has wings which automatically square the knees on the extension when it is attached to the carriage, provided the knees on the carriage and those on the extension are not more than 6 inches out of line. The hooks *B* and catches *C* are fastened on the ends of the different sections of carriage, the former being held in mesh by springs. The sections are coupled by bringing them together, and are uncoupled by pressing down on the foot pedal *D*.

<sup>1</sup> See Figs. 31 and 35.

<sup>2</sup> Not shown in the figure.

<sup>3</sup> Only shown in part in the figure. For details see Figs. 41 and 45.

The carriages are mounted upon six or more pairs of trucks, usually two sets under or near each head block.<sup>1</sup> The wheels range in height from 10 to 18 inches, the usual height being from 12 to 18 inches. The outer wheel is grooved, and travels on a V-shaped track, with a flat face and sides sloping at an angle of  $45^\circ$ . The wheel rides on the flat face, thereby reducing friction. The wheels near the saw line have flat rims and move on a flat track,<sup>2</sup> Fig. 33. The V-rail serves as a guide rail, which ensures the movement of the carriage in a straight line and also keeps the carriage on the track. It is always placed

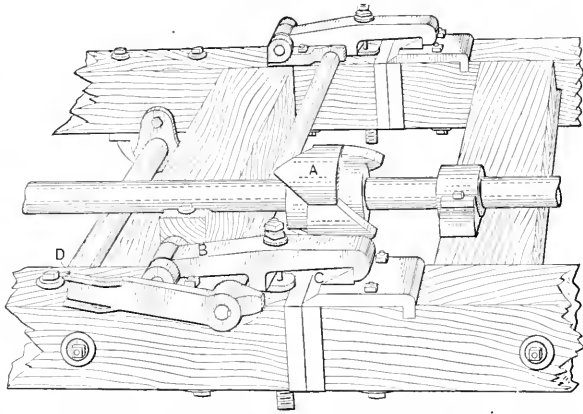

FIG. 32.—An Extension or Trailer for a Sawmill Carriage. A. Set-shaft Coupling Wings which line up the Knees on the Carriage and Trailer. B. A Hook which fits over the Catch C and holds the Trailer and Carriage together. D. A Foot Pedal for releasing B.

on the farthest side of the carriage, because this form of rail offers greater friction than a flat rail, and the load on the carriage is lightest on the farthest side. The up-thrust of the steam nigger also might raise the near side of the carriage slightly and throw it off of a V-rail, with a resulting derailment.

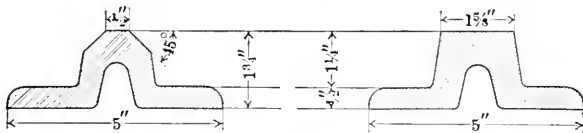

FIG. 33.—Cross-section of the Rails for a Sawmill Carriage.

wheels per axle. When three wheels are used, two wheels are placed close together under the head blocks near the saw line, and when a fourth wheel is used it is grooved and is placed near the outside grooved wheel. Two flat rails and one grooved rail are used when there are three wheels and two flat rails and two grooved rails where there are four wheels.

<sup>1</sup> See page 56.

<sup>2</sup> The wheels on small portable mill carriages are often from 7 to 9 inches in diameter. The track may consist of a flat and a V-rail, or of two T-rails. In the latter case the wheels on both sides of the carriage are flanged.

The gauge of the track varies with the width of carriage frame, often ranging from 54 inches for a small carriage to 84 inches for a heavy three- or four-wheeled Pacific Coast carriage. The length of track varies with the lengths of the carriage and the logs which are to be handled. The track extends from the head-saw toward the front of the mill for a sufficient distance to permit the longest log to be loaded on the carriage without interfering with the saw, and it also extends from the head-saw toward the tail of the mill for a distance which will give ample clearance past the saw blade for the longest log. Mills sawing short logs exclusively, therefore, do not need as long a carriage run as those which occasionally or continuously handle long logs.

The track may be a few feet longer than the carriage on the deck end of a band mill because allowance must be made both for the sawyer's box, between the saw and the deck, and for the maximum length of log. In the circular mill the sawyer's box is usually on the far side of the head saw, so that the extra track length is on the opposite side.

The length of track used with carriages from 20 to 21 feet in length ranges from 45 to 60 feet, while for the long carriages used on the Pacific Coast it may be 140 feet or more in length.<sup>1</sup>

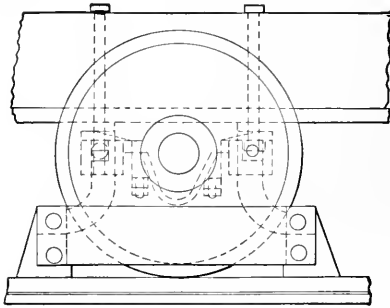

FIG. 34.—A Sawmill Carriage Track-cleaning Device of the Drag-shoe Type.

Track-cleaning devices are used to keep the flat track free from sawdust and rubbish, such as bark, which if not removed might derail the carriage or cause miscut lumber by slightly deflecting the course

of the carriage. Track cleaners generally comprise some form of shoe attached to the front and rear wheels, the shoe dragging on top of the flat rail. One of the standard forms is shown in Fig. 34.

### The Head-blocks.

A head-block is shown in Fig. 35. The base, *B*, is made either of cast iron with steel mountings or of steel and rests upon the framework of the carriage, to which it is securely bolted. It is faced with

<sup>1</sup>The variation in track length is shown by the following data referring to equipment in existing plants. Redwood mill, carriages 19½ and 20 feet long, track length 52 and 54 feet respectively; Lake States mill, hemlock and hardwoods, carriages 18½ and 20¾ feet in length, tracks 48 and 60 feet respectively; Southern mill, carriage 21 feet in length, track 45 feet long; Pacific Coast mill 58-foot carriage, rack 134 feet.

steel plates on which the base of the knee travels. These plates also fit into the grooves, *K*, on each side of the knee, which is thus held upright and in alignment.

The shaft *I*, attached to the set-works, extends from the front to the rear head-block on the carriage and is fitted with a pinion inside the head-block. The heavy-duty carriages used on the Pacific Coast have the set-shaft at the rear end of the blocks, the knees being advanced and returned by means of a steel screw shaft, one end of which is driven through miter gears by the set-shaft, the other end working in a nut

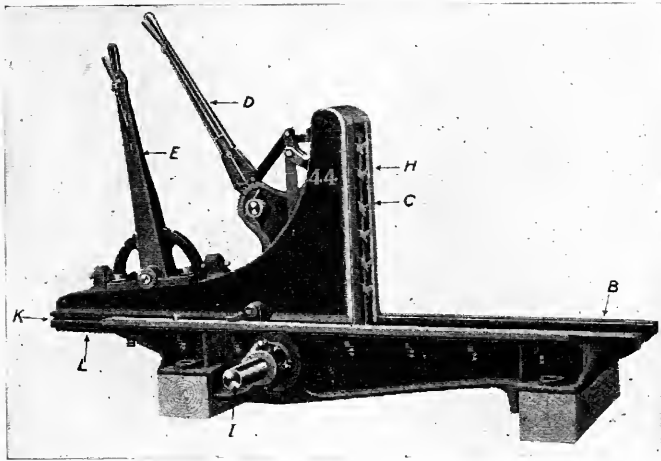

*By permission The Prescott Co.*

FIG. 35.—A Carriage Head Block and Attachments. *B.* Head Block Base. *C.* Knee Face. *D.* Dog Lever. *E.* Taper Lever. *H.* Dogs. *I.* Set Shaft. *K.* Grooves on the Knees which fit over the Steel Plates of the Head Block Base. *L.* Rack on the Base of the Knee which meshes into a Pinion on the Set Shaft.

attached to the under side of the knee. The knee moves on the base of the block in the same manner as in the rack-and-pinion drive.

Head-blocks on a carriage vary in number from two to five, three being used on a carriage of average length. The spacing is not standard for carriages of given length, although on the ordinary three-block carriage, the two head-blocks on the front end are spaced from  $7\frac{1}{2}$  to 9 feet, center to center, and the rear one is from  $3\frac{1}{2}$  to 5 feet from the center one. On a two-block carriage the blocks are from 8 to 12 feet, center to center. The formula on a 58-foot, five-block Pacific Coast carriage was 12-12-10-16 feet, center to center, beginning at the head end of the carriage.

The knees, *C*, consist of a hollow cast-steel framework, to the base of which a rack *L*, Fig. 35, is attached which meshes into the pinion on the shaft *I* and serves to move the knee forward or backward as the shaft is turned in one direction or the other. The taper set quadrant and lever *E* are attached to the rear of the knee and enable the dogger to move a given knee 3 inches either in front of or back of the central position. The object of this device is to permit logs with flaring butts to be sawed in a line parallel to the axis of the log or to the bark. This is accomplished by setting the knee, which is in contact with the flare,

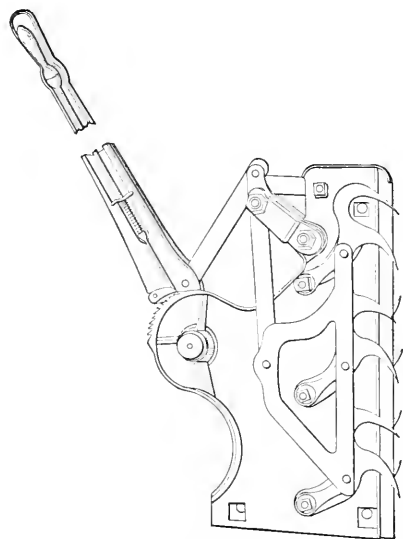

*By permission Phoenix Mfg. Co.*

FIG. 36.—Carriage Dogs of the “Boss” type. One side of the Knee is removed to show the Lever Mechanism for operating the Dogs.

forward or back of the line of the other knees, and if necessary setting some of the other knees slightly forward or backward. After the log has been slabbed on one side and turned, all knees are again set in the “home” position.

The dogs *H*, of which there are many types adapted for special purposes, may be mounted within the knee or on one side of it. The type shown in Fig. 36, known as “Boss dogs,” are in common use at mills cutting logs of average diameter. They are not well adapted for holding very small logs, because the surface which is available for gripping is too narrow. Likewise they are not adapted for very large logs, because they do not penetrate the bark far enough to hold firmly.

The Boss type comprises two sets of dogs operated by one lever, one set working in a downward, the other in an upward direction. The downward-pointing claws should be slightly longer than those pointing upward, otherwise the log or cant may be pushed away from the carriage blocks and cause the “dog-board” to be thin on one edge, or it may be the cause of miscut lumber due to the logs not being held firmly.

A hammer dog, Fig. 37, often is attached to the forward knee of a carriage equipped with dogs of the “Boss” type when small logs are sawed along with larger ones. A hammer dog is especially useful in holding a small log firmly until the first slab is removed and a dogging face secured. It has a quadrant *A*, and a dog *B*, which is heavily

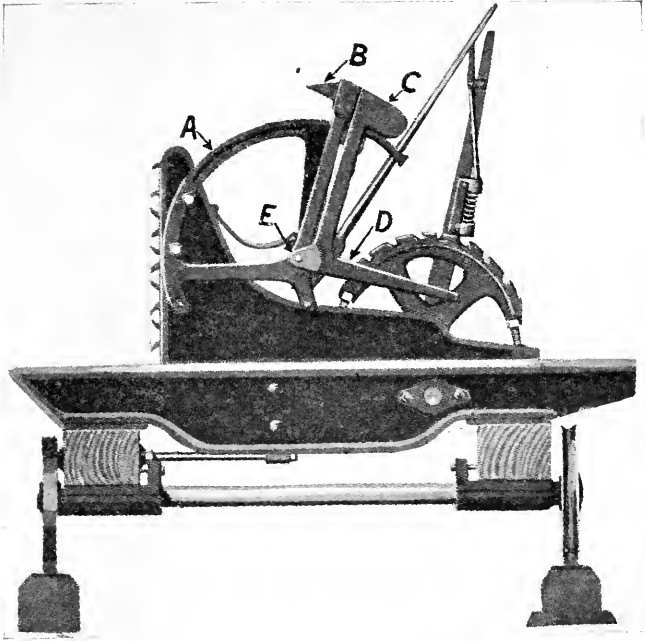

*By permission Clark Bros. Co.*

FIG. 37.—A Hammer Dog used to hold Small Logs until a Dogging Face has been secured. *A.* Quadrant. *B.* Hammer Dog Point. *C.* Weighted Hammer for driving the Dog into the Log. *D.* Dog Lever.

weighted at *C* in order to drive it firmly into the log and is operated by the lever *D*, the dog and handle being hung on a pivot at *E*. The hammer dog, when not in use, rests in the position shown in the figure.

The quartering log dog, Fig. 38, is attached to one side of the knee, and is used to hold logs which are being quarter-sawed. It has an upper and lower jaw, controlled by one lever, which will hold a V-shaped cant securely. When not required for quarter-sawing it can be swung to

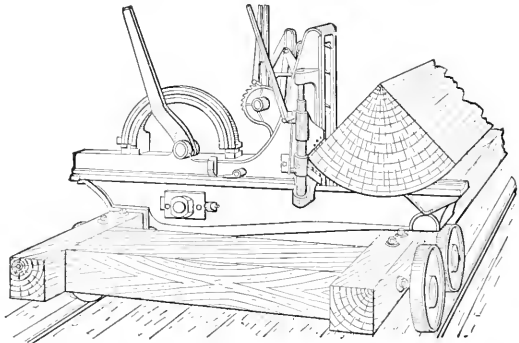
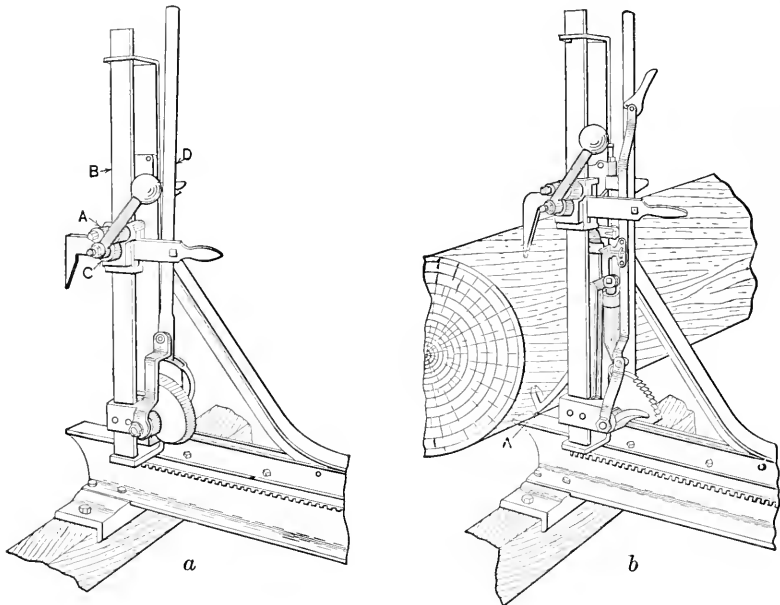

FIG. 38.—A Quartering Log Dog for holding V-shaped Sections. It is attached to the Carriage Knee and may be swung to One Side when not in use.

the side of the knee where it will not interfere with the action of the regular dog equipment. The corner pieces remaining in the

jaws of the dog after the sawing is completed have a 5-inch minimum face. Quartering dogs based on similar principles but of different construction are also on the market.

Single-tooth dogs of the type shown in Fig. 39a are used in mills of small capacity. The head *A*, carrying the dog bit, may be raised or lowered on the sliding bar *B* to any height necessary to accommodate the diameter of the log. The head is loosened or tightened by the lever *C*



*By permission Wickes Bros.*

FIG. 39.—*a*. A single-tooth Log Dog used at Mills of Small Capacity. It has a Head *A* carrying the Dog Bit, a Sliding Bar *B*, a Tightening Lever *C*, and a Lever *D* for forcing the Dog into the Log. *b*. A Duplex Log Dog often used to hold Logs when they are being quarter-sawed.

*C*. In operation, the dog bit is dropped upon the top of the log into which it is forced by the lever arm *D*.

The duplex dog shown in Fig. 39b has a top dog similar to that shown in Fig. 39a. In addition there is a lower dog *A* placed between the two upright bars which is automatically controlled by the same lever as the upper dog. The log is thus gripped both from above and from below. Duplex dogs are especially useful in quarter-sawing.

Special types of dogs are used on the Pacific Coast where very large logs are handled. Hook dogs, Fig. 40 *A*, are in common use, supplemented by spud dogs *B* or by multiple-tooth dogs similar in



character to the Boss dogs. An extension hook *C*, which is driven into the side or top of the log, is also in common use. Low knees of various types are also employed, some with a roller, *D*, on top, others with a wide shovel nose which permits cants or logs to slip over the surface without marring the face of the timber. An objection to the roller-top knee is that the roller may become clogged with bark and dirt and cease to function properly.

A curved hook or "goose neck" often is so attached to one side of each knee, that it projects a foot or more above it, the point of the hook pointing toward the front of the carriage. The object of this hook is to prevent a log from being thrown over the knees when it is being handled by a "steam nigger."

#### Carriage Offset.

Where a single-cutting band head-saw is used it is necessary to equip the carriage with an off-setting device, which will shift the carriage and log away from the cutting line when the carriage is giggered back after a cut has been made. This is necessitated by the liability of the back of the saw catching on a splinter or on the log itself, which might result in pulling the saw from the wheel.

An off-setting device is not used with a double-cutting band head-saw or with a circular head-saw, because the cutting edge of the saw will sever the wood and free itself. An offset of the "drag" type shown in Fig. 41 has a wooden-shod drag shoe *A* traveling on top of the V-rail; a lever arm *B*, one end of which is attached to the shoe and the other to the opposite side of the carriage; a shaft *C* attached to *B* at *D* and to the lever arms *E* and *F*; and the collars *G* and *H*, to which one end of *E* and of *F* are attached. The outer end of the levers *E* and *F* are attached to a casting bolted in the corner of the carriage frame.

The axle attachments *G* and *H* each have a loose collar into the top of which the lower end of a pin on the lever arm *E* or *F* fits, the

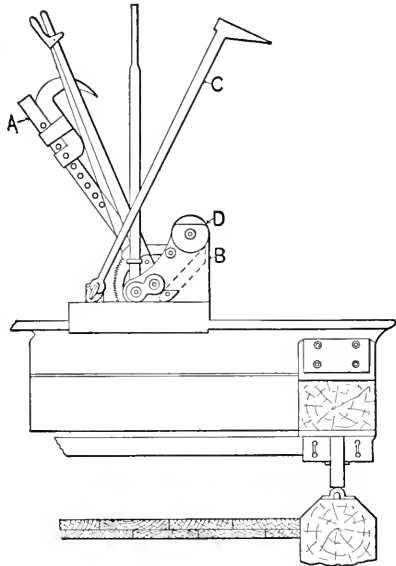

FIG. 40.—A Head Block for a Pacific Coast Sawmill Carriage. *A*. Hook Dog. *B*. Spud Dog. *C*. Extension Hook. *D*. Roller on Top of the Carriage Knee.

upper end of the pin being fastened to a casting *I*, which is bolted to the carriage frame. A collar, rigidly attached to the axle, is placed on either side of the loose collar. When the carriage gigs back the slide *A* drags on the rail, which forces the shaft *C* toward the forward end of the carriage, which in turn causes the lever arms *E* and *F* to assume the position shown in Fig. 41. This forces the pin on the lever arms against one side of the loose collar and shunts the carriage on its axles away from the saw line. Reversing the direction of the carriage causes the lever arms *E* and *F* to straighten out and shunts the carriage over

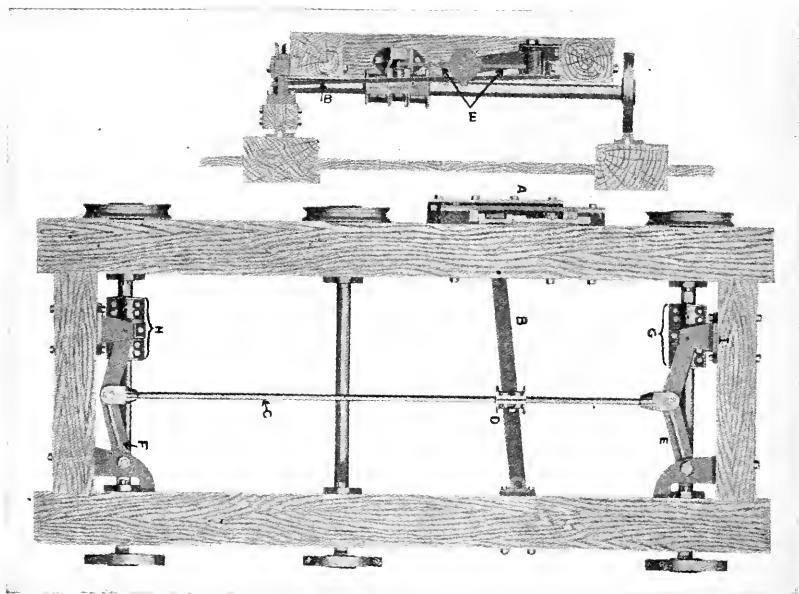

FIG. 41.—A Drag Carriage Offset. *A*. Wooden Shoe which drags on the Rail. *B*. Lever Arm. *C*. Shaft connecting Lever Arms *B*, *E*, and *F*. *G* and *H*. Collars attached to the Carriage Frame by the Casting *I*.

toward the saw line. The sidewise movement on the axles is  $\frac{5}{8}$  inch. Means are also provided for locking the offset mechanism when it is necessary to back the log out of a saw cut. Various other mechanical devices of the drag and other types also are employed for off-setting purposes.

### Set-works.<sup>1</sup>

The purpose of the set-works is to advance the knees toward the saw line in order that a given thickness of slab, board, or timber may

<sup>1</sup> For the position of the set-works on the carriage, see Fig. 31. The set-works shown in this figure are driven by steam.

be cut from the log. Set-works either may be hand- or power-operated, the latter being the more common method in large modern mills.

The chief parts of a hand-operated set-works are shown in Figs. 42 and 43. They are the ratchet-wheel face *A*; the pawls *B*; the index wheel *C*; the set-lever *D*; the set-quadrant *E*; the pawl lifters *F*; the brake band and friction receding lever *G*; the brake wheel *H*; the brake band *I*; the set-lever stop *K*, and the set-shaft *L*. The set-shaft *L* extends from the front to the rear head-block<sup>1</sup> and carries a pinion wheel under each knee which meshes into a rack on the under side of the knee. The ratchet wheel *A*, is attached to this set-shaft and is actuated by the front pawl link *M* and the rear pawl link *N*,

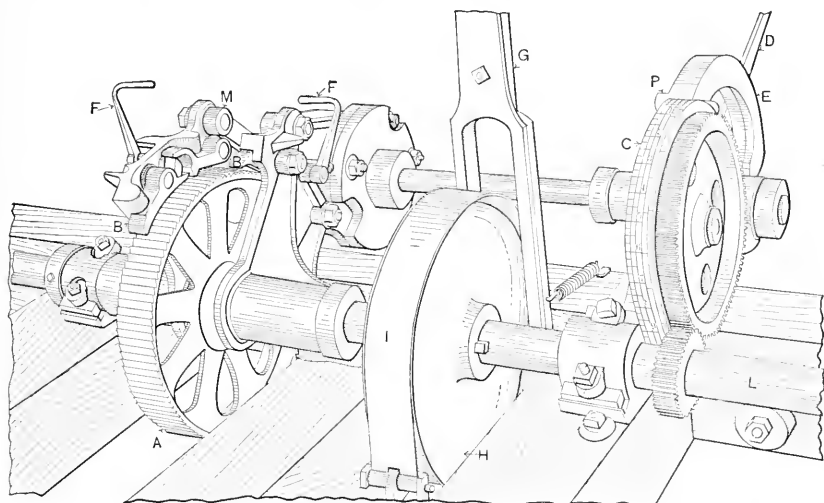

By permission Allis-Chalmers Mfg. Co.

FIG. 42.—Front view of a Double-acting Hand-operated Carriage Set-works.

*A.* Ratchet Wheel. *B.* Pawls. *C.* Index Wheel. *D.* Set-lever. *E.* Set Quadrant. *F.* Pawl Lifters. *G.* Friction Receding Lever. *H.* Brake Wheel. *I.* Brake Band. *L.* Set Shaft. *M.* Front Pawl Link. *P.* A Stop on the Set Quadrant.

both of which are attached to the set lever shaft *O*. When the set-lever *D* is pushed forward the pawls *B* mesh into the ratchet-wheel face and turn the set-shaft forward. When the set-lever is brought back to home position the rear pawls<sup>2</sup> attached to *N* mesh into the ratchet wheel and by a lifting motion turn the shaft in the same direction as formerly. The set-works are therefore double-acting. Single-acting set-works which set on the forward stroke only are commonly used on portable sawmill carriages.

The length of the stroke of the set-lever *D* is controlled by the set-lever stop *K* which meshes into slots on the set-quadrant *E*. Each

<sup>1</sup> See Fig. 31.

<sup>2</sup> Not discernible in the cut.

slot on the quadrant represents a given thickness. Set-works may be adjusted to operate by differences as small as  $\frac{1}{32}$  inch, although they are usually made for differences of  $\frac{1}{16}$  inch. The length of stroke of the set-lever *D* determines the distance the knees are advanced, the lever being pulled down until it strikes the stop *K* and then thrust forward until it strikes the stop *P*, which completes the operation.

The brass-faced, index wheel *C* has a geared circle which meshes into a pinion on the set-shaft. The face of the index wheel is divided into several columns. The first column is graduated to show the number of inches from the face of the knee to the saw line. The remaining

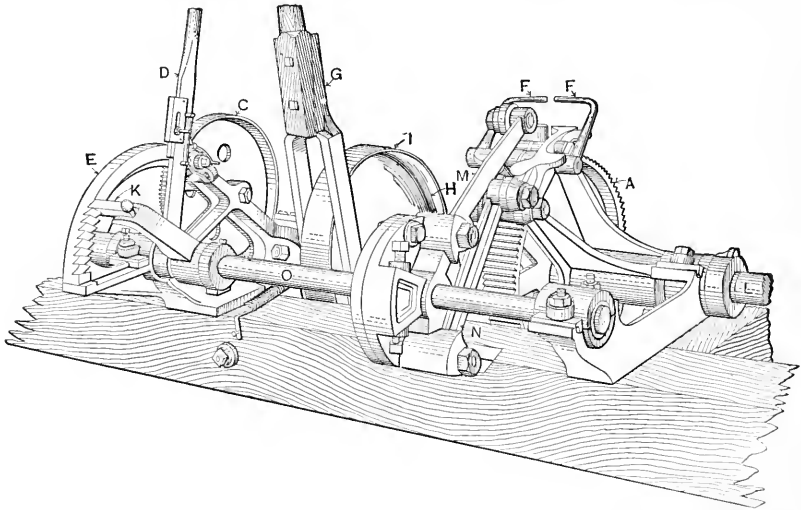

*By permission Allis-Chalmers Mfg. Co.*

FIG. 43.—Rear view of the Double-acting Hand-operated Carriage Set-works shown in Fig. 42. *A.* Ratchet Wheel. *C.* Index Wheel. *D.* Set Lever. *E.* Set Quadrant. *F.* Pawl Lifters. *G.* Friction Receding Lever. *H.* Brake Wheel. *I.* Brake Band. *K.* Set-lever Stop. *L.* Set Shaft. *M.* Front Pawl Link. *N.* Rear Pawl Link. *O.* Set-lever Shaft.

columns each show the number of cuts of a given thickness, kerf included, which can be secured from a section of log of the thickness shown by the inch column. The columns are usually graduated by  $\frac{1}{4}$  inch differences from 1 inch to 2 or  $2\frac{1}{2}$  inches. For example, if the distance from the saw line to the face of the knees is 48 inches the inch scale will read 48 inches and the remaining columns will show the number of pieces of 1-inch,  $1\frac{1}{4}$ -inch,  $1\frac{1}{2}$ -inch and other thickness which can be cut. The index wheel automatically turns away from the 48-inch mark as the knees are advanced toward the saw line, always recording the exact distance. The index wheel is in plain view of the setter, so that it can be readily observed. The markings on the dial are shown in Fig. 44.

A mechanism for withdrawing the knees from the forward to the rear end of the blocks is necessary, and is a part of the set-works. This device usually is driven by friction gears actuated by the motion of one of the carriage axles or else by a heavy coiled spring or by both. When friction gears are used a short shaft is hung on suitable bearings, between two of the cross timbers of the carriage and parallel to the set-shaft. One end of this short shaft carries a miter gear which meshes into a similar gear attached to an axle of the carriage. The shaft is hung on a movable bearing under the brake wheel, and has a small paper friction attached to it. The movement of the movable bearing is controlled by the friction receding lever *G*, Fig. 43. When the carriage is giggered back after the "backing board" has been pushed off from the carriage the setter, by means of the lever *G*, throws the paper friction into contact with the brake wheel *H*, which causes the set-shaft to rotate in a direction away from the saw line and the knees to recede. The progress of the knees is stopped by reversing the lever *H*, which throws off the power and applies the brake band *I* to the brake wheel. The friction gears are not visible in Figs. 42 and 43, but a similar arrangement is shown in Fig. 45. In order to recede the knees it is necessary to raise the pawls off

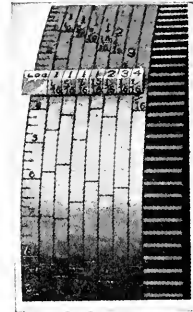
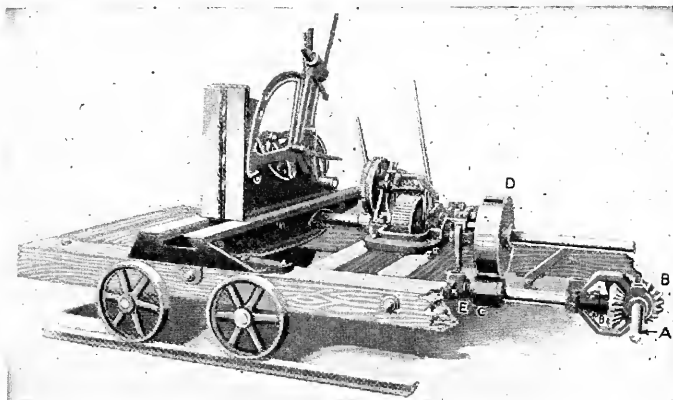

FIG. 44.—A Set-works Dial showing the Markings which indicate the Distance from the Saw Line to the Face of the Knees, and also its equivalent in Cuts of Various Thicknesses.



By permission Clark Bros. Co.

FIG. 45.—Friction Receding Mechanism for a Sawmill Carriage. *A*. Carriage Axle. *B*. Miter Gears. *C*. Paper-faced Friction Wheel. *D*. Iron-faced Friction Wheel. *E*. Movable Shaft Bearing.

of the ratchet wheel by means of the pawl lifters *F*. When the set-lever is against the stop *P*, the pawl lifters are opposite each other and can be raised with one motion of the hand. In some set-works the pawls are automatically lifted when the friction receding device is thrown into gear.

A strong coiled spring *G*, Fig. 31, is sometimes used as a receding device. One end of the spring is attached to the head-block of the carriage and the other end to the set-shaft. As the knees are advanced toward the saw line the spring is coiled up. On raising the pawls above the ratchet wheel, the spring uncoils and causes the set-shaft to reverse,

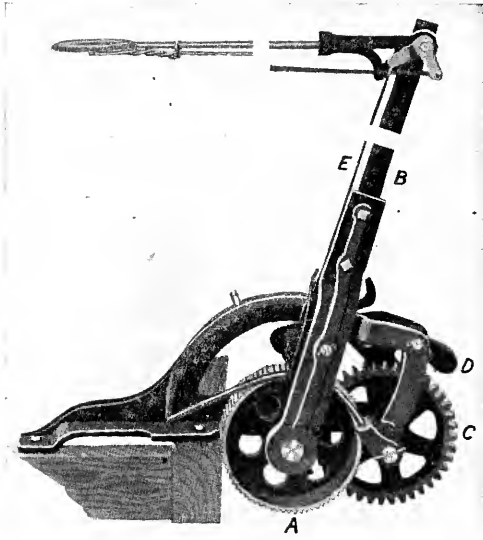

*By permission American Sawmill Machinery Co.*

FIG. 46.—A Carriage Set-works and Receder for use with Portable Sawmills. *A*. Ratchet Wheel on the Set Shaft. *B*. Set and Receding Lever. *C*. Receding Gear. *D*. Pawl. *E*. Pawl Lifter.

which in turn causes the knees to recede. The movement of the knees is stopped by a friction brake similar to that shown in Figs. 42 and 43. This type is used on many of the smaller carriages and may also be used as an auxiliary on a carriage having a friction receding device.

Portable mill carriages usually have a simple combination setting and receding device, or a simple geared receding device, with which a brake wheel is unnecessary. A type of combined setting and receding mechanism is shown in Fig. 46. This has a ratchet wheel *A* mounted on the set-shaft, a set and receding lever *B*, a receding gear *C*, and a rear pawl *D*. When in the position shown in the cut, the pawls on the ratchet wheel are in gear and a forward and back motion of the lever *B* will set the knees forward. By pulling up on the rod *E*, the pawls on the ratchet wheel are raised and the rear pawl *D* thrown into contact with the receding gear *C*. A forward and rear motion of lever *B* will then cause the knees to recede at a speed about three times faster than they are set forward.

Steam-driven set-works have largely supplanted hand set-works in

large mills because of their greater efficiency. In principle, they do not differ from hand set-works except as to the character of power used. One of the standard types is shown in Fig. 47. The ratchet wheel and pawls are enclosed in the case *A*, the former being attached to the set-shaft *B*. Power is furnished by the steam cylinder *E*, to the piston of which is attached the rack *D*, which meshes into the pinion *C*, which, in turn, through the double-acting pawl levers *F*, cause the set-shaft to rotate.

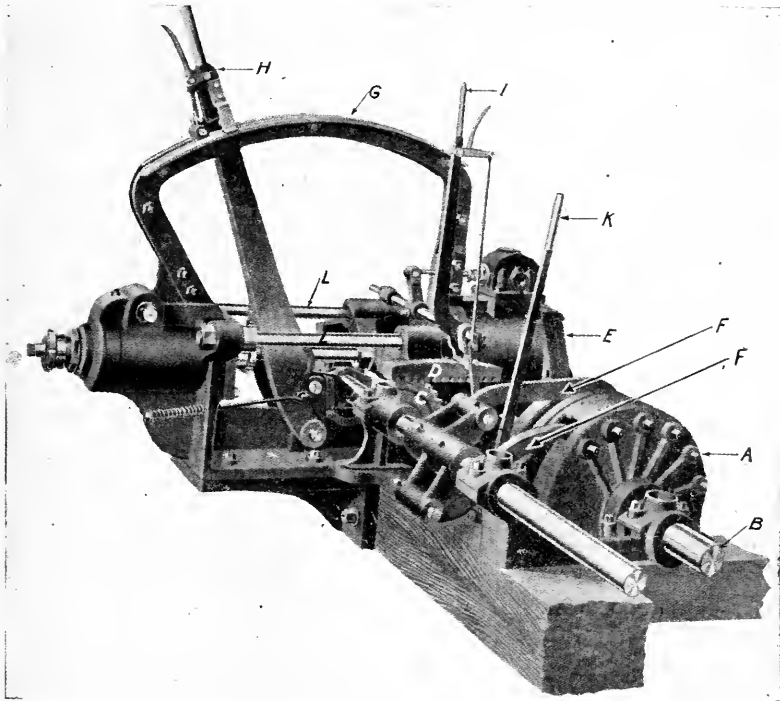

*By permission The Prescott Co.*

FIG. 47.—A Steam-driven Set-works for a Sawmill Carriage. *A*. The Case enclosing the Ratchet Wheels and Pawl Heads. *B*. Set Shaft. *C*. Pinion which meshes into the Rack *D*. *E*. Steam Cylinder. *F, F*. Double-acting Pawl Levers. *G*. Set Quadrant. *H*. Stop Lever. *I*. Throttle Lever. *K*. Receding Lever and Brake.

The set-quadrant is shown at *G*, the stop lever at *H*, the throttle lever at *I*, and the brake and receding lever at *K*. The stop lever *H*, is set at the desired thickness, and when the throttle is opened the piston and rack are driven toward the rear until the former strikes the base of *H*, when the throttle is reversed, which forces the piston and rack forward to the original position. Steam is furnished by means

of a telescopic feed pipe of suitable length, one end of which is attached to the base of the set-works cylinder, the other to the main steam-feed pipe. The exhaust from the cylinder is discharged through another telescopic pipe.

On Pacific Coast carriages, when steam set-works are used the set-shaft is at the rear of the head-blocks, the screw which actuates the knee being driven by miter gears placed on the set-shaft and the screw shaft.

Set-works actuated by an endless-rope feed are in common use on the Pacific Coast where very large timber is handled and to some extent in other regions. The advantages of the rope-driven set-works, as compared to steam, are that they may be used for any length of carriage run, require a minimum of power, and are free from the annoyance of leaky steam pipes. Their chief drawback is the liability of rope failure when in constant use. The set-works has an upright stand, on which are mounted the ratchet wheel and pawls; the index wheel hung on a vertical axis; a revolving set-lever stop; and the necessary gears for transmitting power to the set-shaft. Power is communicated to the set-works by an endless manila rope which passes over a sheave at each end of the carriage run and then over one sheave and under another on the set-works. A small paper friction is mounted on the shaft of each sheave on the set-works and when the paper friction is thrown against an iron-faced brake wheel, power is transmitted to the set-works by means of miter gears. A rope tightener and a rope driving device are installed under the sawing floor.

Set-works operated by electrical power have been introduced within recent years in some sawmills which use an electrical drive. The advantage claimed for this form of drive is largely one of low maintenance expense and more continuous operation with only an average amount of attention to mechanical up-keep. The equipment has a motor mounted on the carriage with some form of trolley device to connect the motor with the feed wires. Two sizes of motor are in use, a 5 horsepower for medium-sized timber and a 10 horsepower for the large set-works on Pacific Coast carriages. Motors are of the squirrel-cage, three-phase type, using an alternating current and running at a speed of approximately 1150 revolutions per minute. They are usually belted to the set-works.

The early form of power take-off consisted of feed wires draped through rings that were free to slide over a taut messenger wire stretched parallel to the track. This method did not prove fully satisfactory because the constant bending of the feed wires, as the carriage traveled back and forth, caused them to break at the folds. Recent installations have used some form of trolley, either with wheel or finger contact.



### Carriage Drive.

There are three methods used for driving sawmill carriages, namely, the rack-and-pinion feed, the cable feed, and the steam feed. The first type is found only on small carriages and is chiefly used by portable mills. A simple form of the second type is used by small mills and a specialized type by large mills where extra long carriages are needed. The third type, steam feed, is in very extensive use at large plants which handle logs of average lengths.

*Rack-and-pinion.*—The rack-and-pinion feed works, Fig. 48, has a rack stick *A*, attached to the under side of the carriage frame, one

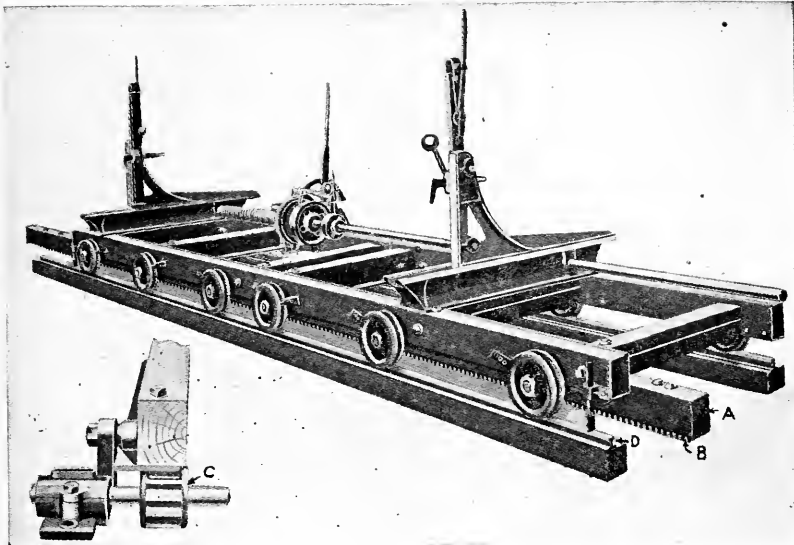

FIG. 48.—A Rack-and-pinion Feed Works for a Sawmill Carriage. *A*. Rack Stick. *B*. Rack. *C*. Pinion Wheel which meshes into the Rack and moves the Carriage. *D*. Carriage Track.

end of which projects far enough beyond the carriage to provide the required length of run. The pinion wheel *C* meshes into the rack *B*, which is attached to the base of this timber. The shaft of the pinion wheel passes under the track *D*, and is hung on suitable bearings on the saw husk. The pinion shaft may be actuated either by a friction device, by a belt drive, or by a combination of both.

There are several forms of friction drives, one of which, shown in Fig. 49, has a friction disk *A* attached to the drive shaft, a forward-motion friction wheel *B*, a gig-back friction *C*, and the lever *D*. By a movement of the lever *D*, the friction wheel *B* is thrown against the friction disk *A*, which transmits power to the pinion shaft *E* through

the miter gears *F*, thus driving the carriage forward. The speed at which the pinion is driven can be increased or decreased by turning the wheel *G*, which in turn moves wheel *B* along the slotted shaft on which it is hung. The speed of *B* is dependent on the circumference of the circle of contact on *B*. By reversing lever *D* the friction wheel *C* is thrown against the friction disk *A* and the carriage is giggered back.

A type of belt-and-friction feed has a bull wheel or iron-face friction wheel *A*, Fig. 50, mounted on the shaft carrying the pinion. On either side of the bull wheel are placed paper frictions *B* and *C* driven by the drive pulley *D*. Pulley *E* is an idler and *F* a belt tightener. The

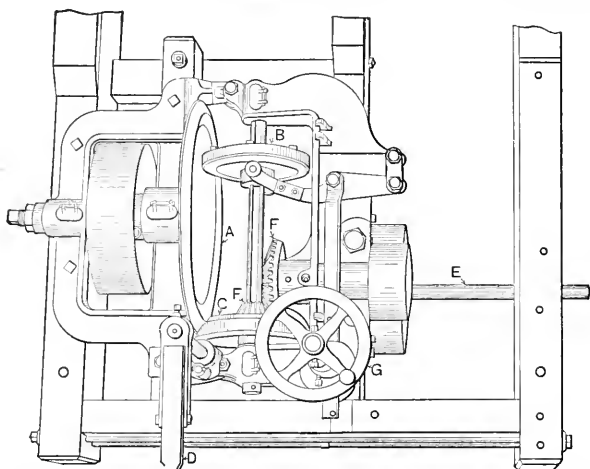

FIG. 49.—A Friction Drive for a Small Sawmill Carriage equipped with a Rack-and-pinion Feed. *A*. Friction Disk or Bull Wheel attached to the Saw Arbor. *B*. Forward-motion Friction Disk. *C*. Gigger-back Friction Disk. *D*. Control Lever. *E*. Shaft with Pinion Wheel (not shown) attached on the Right which meshes into the Rack on the Carriage Frame. *F*. Miter Gears which drive Shaft *E*. *G*. Speed Control Hand Wheel for shifting the Friction Disk *B* along the Shaft.

rig is so belted that friction pulleys *B* and *C* run in opposite directions. By means of the single lever *G* the bull wheel can be shifted against either *B* or *C*, thus driving the carriage forward or giggering it back as desired.

In the belt feed shown in Fig. 51, *C* is the flange-driven pulley, *D* a belt pulley on the feed shaft, *A* an "idler" pulley connected to the husk by a tightening rod, and *B* the tightener pulley directly connected to the sawyer's lever handle. A rear motion of the lever tightens the bolt and drives the carriage forward.

A friction gigger-back arrangement is shown in Fig. 52 which has a mandrel friction pulley *E*, a friction pulley *G* on the feed shaft, and

an idler *F* which is carried by rocker arms fastened to the same shaft to which the tightener pulley *B* is attached. A forward movement

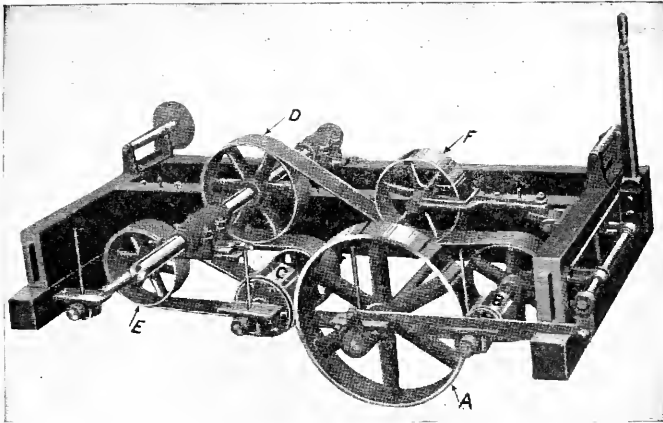

*By permission American Sawmill Machinery Co.*

FIG. 50.—A Belt and Friction Feed for a Sawmill Carriage. *A.* Iron-faced Friction Wheel. *B.* Paper-faced Friction Wheel for driving the Carriage forward. *C.* Paper-faced Friction Wheel for giggering the Carriage. *D.* Drive Pulley. *E.* Idler. *F.* Belt Tightener.

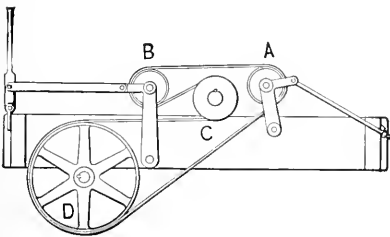

FIG. 51.

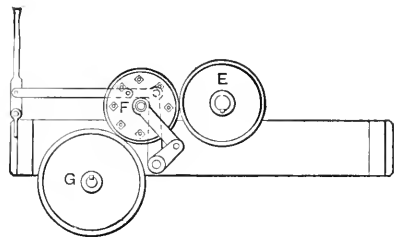

FIG. 52.

FIG. 51.—A Belt-feed Drive for a Portable Sawmill Carriage. *A.* An Idler. *B.* A Tightening Pulley manipulated by the Lever shown at the Left. *C.* A Flange Pulley driven by the Saw Arbor. *D.* A Pulley on the Feed Shaft which drives the Carriage by means of a Rack-and-pinion. This device is used in connection with the Gig-back shown in Fig. 52.

FIG. 52.—A Friction Gig-back for a Portable Sawmill Carriage. *E.* Friction Disk (power-driven) which is attached to the Saw Arbor. *F.* An Idler by means of which Power may be transmitted from *E* to the Friction Disk *G* on the Feed Shaft. This device is used in connection with the Belt Feed shown in Fig. 51.

of the sawyer's lever loosens the feed belt, releases the feed, and brings the friction *F* in contact with the friction pulley *E* and with *G* on the feed shaft. This reverses the feed shaft and gigs back the carriage.

The variable-friction feed, Fig. 49, is regarded by some as a more desirable type than the belt feed and friction, Fig. 50, or the belt feed, Fig. 51, because there are no belts to slip or break. With the same power it is claimed that a mill equipped with the variable-friction feed may cut from 25 to 40 per cent more timber than where either of the other types are used.<sup>1</sup>

*Cable.*—The cable feed which is used on small portable sawmill carriages uses the same feed works as the rack-and-pinion drive, the

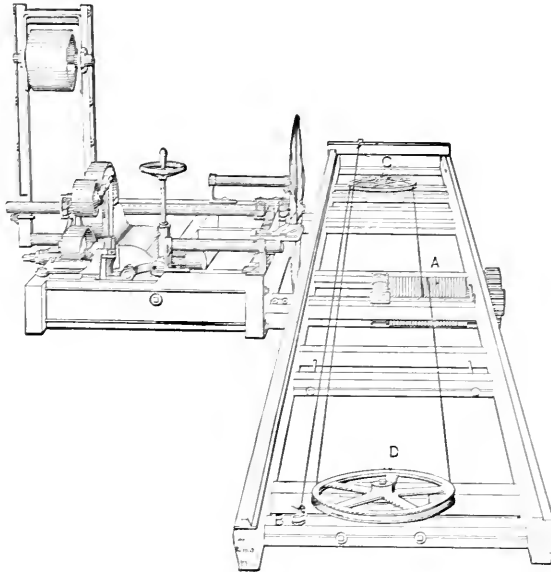

FIG. 53.—A Cable Feed for a Portable Sawmill Carriage. A. The Power-driven Grooved Drum which drives the Cable. B. One Point of Attachment of the Cable to the Carriage. C and D. Idlers or Sheaves, attached to the Carriage Frame, around which the Cable passes.

rack being replaced by a flat-faced or grooved drum A, Fig. 53. The driving cable is fastened at one end of the carriage frame B, then passes to the far end of the run around a sheave C, back to the drum A, around which it is passed three or four times, then to sheave D and back to the opposite end of the carriage near C. By rotating the drum A in the proper direction the carriage is pulled forward or giggered back as desired. The cable is of steel and varies in diameter from  $\frac{3}{8}$  to  $\frac{1}{2}$  inch, depending on the size of the carriage.

The cable feed is better adapted for medium and large sawmills, than the rack-and-pinion, because the carriage is lighter and runs more smoothly when relieved of the weight of the rack stick and rack, especially when the axle bearings have become worn and the rack meshes too deeply in the pinion. A rack-and-pinion feed limits the carriage run to the length of the rack stick, while a cable feed can be arranged to give any desired length of carriage run by the proper spacing of the sheaves C and D.

<sup>1</sup> See *Small Sawmills*, by Daniel E. Seerey, United States Department of Agriculture, Bulletin No. 718, Washington, 1918, page 11.

A standard type of arrangement for a large sawmill is shown in Fig. 54. Power is furnished by the duplex feed engine *C*, the drive wheel of which is grooved to receive the cable. Two idler sheaves, *D*, over which the cable passes are placed near the opposite end of the carriage run. The top of the sheaves, *D*, are placed about level with the track under the center of truck *A*, when the carriage is at the log deck, and the engine drum is placed at the same height under the center of truck *B* when the carriage is at the end of the run.

Two cables are used, the ends of each being attached to opposite ends of the carriage as shown in the figure. The single sawyer's lever *E* controls all valve action, a forward thrust of the lever giggering back

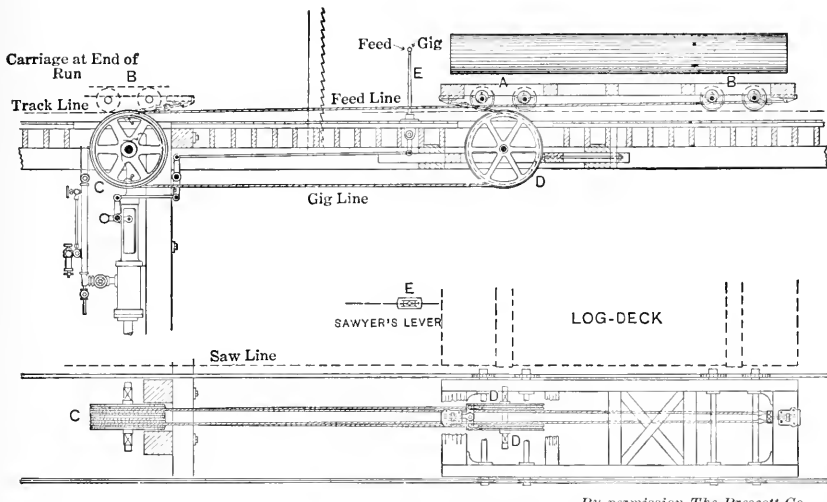

By permission The Prescott Co.

FIG. 54.—A Cable Feed Drive for a Sawmill Carriage. *C* is a Duplex Feed Engine, and *D, D* are Idlers over which the Cables run.

the carriage, while a rear pull reverses the direction of travel of the engine and drives the carriage forward. A single cable is used with light equipment. The size of the feed cable varies from  $\frac{1}{2}$  to  $\frac{3}{4}$  inch for the duplex feed, and from  $\frac{3}{4}$  to  $1\frac{1}{8}$  inches for a single-cable feed. The equipment is built for a length of carriage run up to 185 feet. A cable-rope drive is used in large mills where long logs are sawed because there is excessive wear on the piston and on the cylinder stuffing-box of a long steam-feed cylinder, and also because the steam requirements are too great.

*Steam.*—The steam-feed carriage drive is the fastest form for carriages of medium size and is in extensive use in all parts of the country. Its introduction marked a great increase in the output of sawmills. The steam feed shown in Fig. 55 has a sectional cylinder of the length

required for the carriage run, with a bore from 8 to 14 inches, usually 12 or 14 inches, into which is fitted a piston head carrying a piston, the free end of which is attached to the under side of the tail-end of the carriage. The cylinder is bolted to the floor between the tracks near the flat rail. It must be long enough to permit the carriage to go the full length of the track. The remainder of the cylinder extends beyond the tracks toward the tail of the mill. The cylinder is bolted to the floor timbers at a height which will permit the carriage frame to clear it. The piston rod passes through a stuffing-box at the end of the cylinder and is attached to the carriage by an iron bracket, Fig. 55 *A*, which permits a slight horizontal motion to the carriage when the off-set acts, and also a slight vertical motion in case there is any upward movement when the feed is reversed.

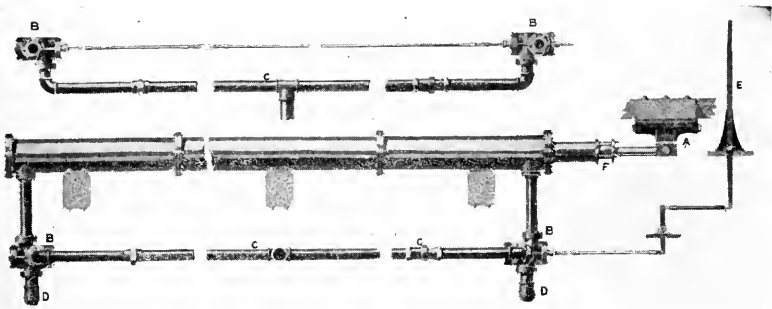

*By permission The Prescott Co.*

FIG. 55.—A Direct-acting Steam Carriage Feed. *A*. Bracket Attachment to the Carriage. *B*. Valves. *C*. Feed Pipe. *D*. Exhaust Pipe. *E*. Sawyer's Control Lever. *F*. Stuffing Box on Cylinder head.

Steam port pipes are attached to the under side of each end of the cylinder and pass through the floor to the valve chest. Steam for actuating the piston head is admitted alternately at each end of the cylinder. Steam-feed pipes lead from the boilers to the side of each valve chest, the exhaust pipes usually being attached to the bottom. When the cylinder is not more than 30 feet in length a single valve action is sometimes used. It is placed midway between the two ends of the cylinder, having a single steam pipe and a single exhaust pipe. The single valve is not adapted for long cylinders because there is too great a loss of steam from the use of long port pipes.

The valves are operated by the sawyer, by means of a single lever and suitable rod connections as shown in Fig. 55. When the lever is in a vertical position or plumb, the carriage is at rest. Throwing the lever either forward or backward opens the valve on one end of the cylinder and the exhaust on the opposite end, the exhaust remaining

open until the lever is again brought back to vertical. This lever serves the same function as an eccentric on an engine.

The length of the cylinders depends upon that of the carriage and of the run. In a standard two-band mill having carriages from 21 to 30 feet long, the length of the steam-fed cylinder is usually from 60 to 70 per cent of the length of the carriage track.

### Bumpers.

Carriage bumpers are used at each end of the track to act as cushions for taking up the shock in case the carriage gets beyond control. They are of several types, namely a spring, a pneumatic, and a combination steam and pneumatic bumper.

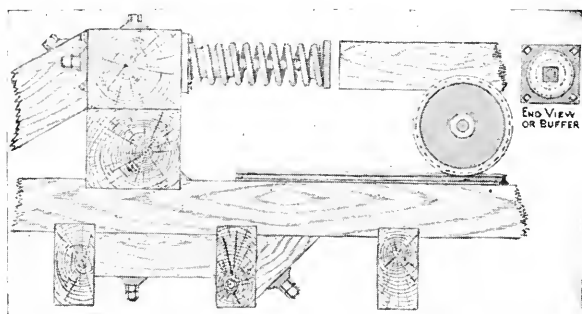

FIG. 56.—A Spring Carriage Bumper.

The pneumatic bumper has a milled cylinder fitted with a piston and a rod, and a strong coiled spring, similar to that shown in Fig. 56, which holds the piston in position when not in use. When the carriage

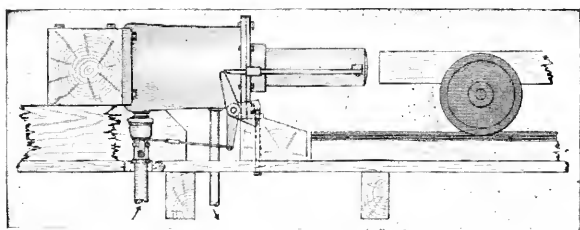

FIG. 57.—A Combination Steam and Pneumatic Carriage Bumper.

strikes the piston it is brought to a gradual stop by the compression of the air.

The character and form of mounting of the spring type is shown in Fig. 56. These are usually mounted in pairs, one pair at each end of the track.

The combination steam and air bumper shown in Fig. 57 has a cylinder, fitted with a piston head and a rod, the latter extending out so as to receive the blow of the carriage. On the outer end of the piston rod there is a rod connection to a gate valve in a steam feed pipe that enters the back end of the cylinder. This steam pipe is equipped with a check valve which prevents the escape of steam or air. When the device is at rest, a small amount of steam passes through the valve into the cylinder, keeping the piston head to the front. Air enters the cylinder and later escapes through a small port near the front end. When the carriage strikes the piston, the front port is closed, confining the air; the steam valve is opened, permitting an inrush of steam which continues until the pressure is equal to the steam pressure in the feed pipe. As soon as the pressure on the piston head is released, the steam forces it forward until it passes the front port, when the steam valve is closed.



## CHAPTER IV

### SAWMILL EQUIPMENT (*Cont.*)

#### HEAD-SAWS

THE sawing machinery may be grouped into head-saws, which reduce logs to boards, planks, or cants; and resaws, which re-manufacture the material cut by the head-saws. Head-saw mills are either of the circular-saw or band-saw type, while resaws may be of the circular, band, or gang type. Many mills have head-saws only, doing all the sawing on the main carriage, while others have a combination of a head-saw or saws and one or more types of resaws. The circular head-saw is used in portable mills and to a large extent in semi-portable ones. Many mills cutting 30,000 board feet or more per day use band saws because an increased output can be secured from a given volume of logs,<sup>1</sup> and also because band-sawed lumber usually is more free from saw marks and is more evenly sawed.

Circular mills sometimes are used, because of their greater capacity, where large quantities of small or low-grade logs are handled. Maximum daily output per crew is usually the goal, since such logs can yield only a very small per cent of the better grades.

Band mills are more expensive to install and usually it costs more to keep the saws in condition. An equal amount of skill is required to keep either type of saw in first-class condition, but a band saw will not cut lumber satisfactorily unless it is properly fitted, while a circular saw will run and manufacture lumber even though it is not in first-class condition. Many operators, especially of small capacity mills, do not give the sawing equipment proper attention and consequently an inferior sawed product often is produced at such plants.

Pony band mills are in use to a limited extent in semi-portable plants sawing high-priced stumpage where the output per set-up is at least one million board feet.

<sup>1</sup> Circular saws cut a kerf of from  $\frac{1}{4}$  to  $\frac{5}{16}$  inch, while band saws remove from  $\frac{1}{8}$  to  $\frac{3}{16}$  inch. The band saw came into extensive use in the sawmills of Minneapolis, Minn., in 1889. Previous to this year the overrun had ranged from 9.2 per cent in 1881 to 13.2 per cent in 1888. The first year (1889) that band saws were extensively used the overrun was 18.4 per cent while in 1890 it was 19 per cent, a maximum increase of 5.8 per cent.

### Circular Mills.

*Single.*—The circular mill, Fig. 58, has a husk or frame with a main shaft or arbor *A* on which the saw and the drive pulley *B* are mounted; a saw guide *C*, which steadies the saw; a board spreader *D*, to prevent the board from binding on the saw; a board roll *F*, Fig. 59, and in portable mills <sup>1</sup> devices for driving the carriage.

An iron husk is used for large circular mills and a wooden husk for portable mills. A metal flywheel is sometimes mounted on the main arbor. Husks are built in varying sizes to carry saws ranging from 48 to 72 inches in diameter, depending on the maximum size of timber cut.<sup>2</sup>

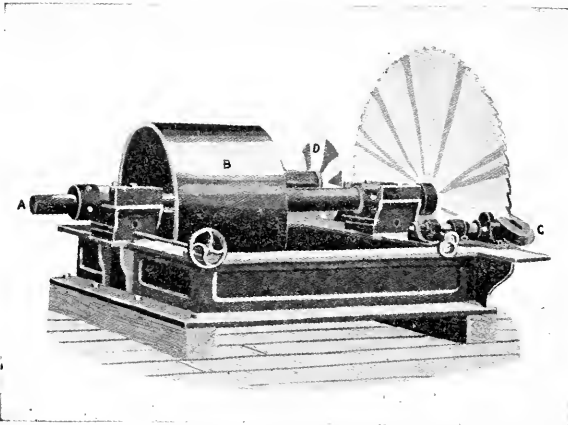

Fig. 58.—A Single Circular Mill. *A*. Saw Arbor. *B*. Driving Pulley on the Arbor. *C*. Saw Guide. *D*. Board Spreader.

*Double.*—A double circular mill, Fig. 59, often is used where large timber is handled. This has a frame, superimposed upon the husk, on which an arbor is mounted that carries a top saw and a pulley, which is belt-driven by a pulley on the main arbor. An inverted top-saw rig may be substituted for the one described, the frame being suspended from timbers overhead. The main saw and the top saw cut on the same line, the center of the top-saw arbor being placed slightly forward of the center of the main arbor, so that the cutting line of the two saws will meet. The top saw rotates in a direction opposite to that of the main saw, in order that the sawdust from the former may not be thrown into the cut of the latter and cause the lower saw to bind.

<sup>1</sup> See Figs. 48, 49, 50, 51, 52 and 53.

<sup>2</sup> A 132-inch saw was exhibited at the Alaska-Yukon-Pacific Exposition but, so far as known, it was not used in a sawmill.

Double circular mills are regarded with favor where both medium and large logs are handled, since saws of smaller diameter and gauge can be used. When sawing logs of small size the power may be taken off of the top saw by raising the lever *E*, which in turn raises the idlers *D* from the driving belt.

The daily output of a circular mill in hardwoods usually is from 25,000 to 35,000 board feet and in softwoods from 40,000 to 60,000 board feet. Available records show an output in southern yellow pine

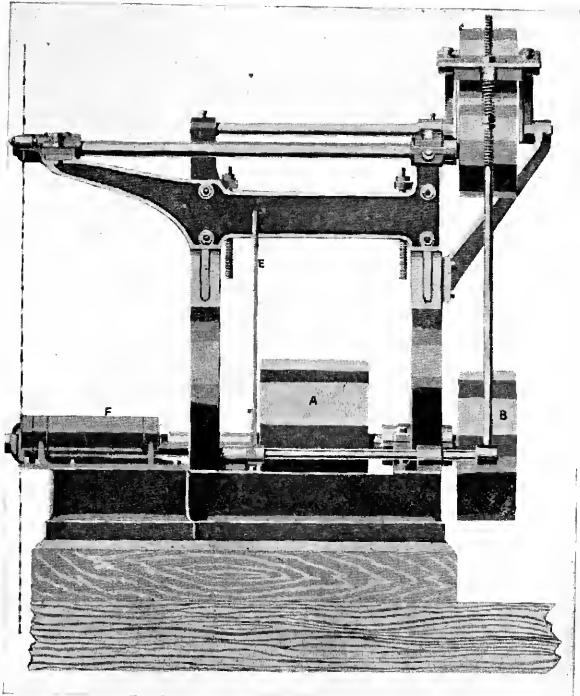

*By permission The Prescott Co.*

FIG. 59.—A Double Circular Head-saw. *A.* Driven Pulley on the Saw Arbor. *B.* Driving Pulley for the Top Saw. *E.* Belt Tightener Lever for Top Saw Idler. *F.* Board Roll.

of 153,000 board feet, 317 logs, in ten hours, which probably is near the maximum for this type of head mill.

The average rim speed of a circular saw in a large mill is approximately 10,000 linear feet per minute. The number of revolutions, therefore, varies directly with the diameter of the saw. In small mills of the portable type the speed is lower because there is rarely power enough available to make a high rate of feed possible. The rate for

a 48-inch saw driven with low power is usually from 1200 to 1500 linear feet per minute.<sup>1</sup> Portable mills are often underpowered, the horsepower varying from 10 to 20, while in large mills the engine horsepower used to drive a circular head saw varies from 100, in a mill cutting small and medium-sized timber, to 250 in a large Pacific Coast mill.

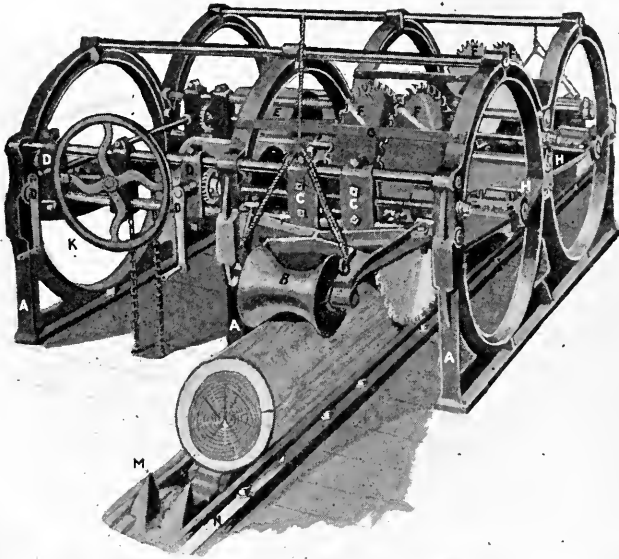

*By permission M. Garland Co.*

FIG. 60.—A Four-saw Gang Canter used for slabbing Logs. A. Steel Framework. B. Front Binding Roll. C. Brackets carrying the Saw Guides. D. Levers for shifting the Saws on the Arbor. K. Hand Wheel for Speed Control. M. Cast-iron Shoe for keeping the Feed Chain in Alignment. N. Adjustable Side Piece for taking up Wear on the Feed Chain.

### Twin Circular Mill.

This is sometimes used to slab small- and medium-sized logs on two sides for gang sawing. It is rarely seen in mills to-day. The twin circular mill has two saws about 40 inches in diameter, both mounted on the same arbor. The saws are fitted with collars having opposite slots which fit over lugs on the arbor so that the distance between saws can be increased or decreased by moving the saws along the arbor either away from or toward each other. The log is moved past the saw by an endless chain equipped with log dogs which travels between

<sup>1</sup> For a further discussion of this subject, see page 116.

the saws underneath the arbor.<sup>1</sup> A similar machine known as a *tie mill* or *gaug canter*, Fig. 60, is equipped with four saws and is designed to make two slabs, two boards, and a cant at one operation. The saws are 40 inches in diameter and will cut logs 17 inches or less in diameter. The rated capacity of the machine is from 1800 to 2000 logs per day.

### Breaking-down Mill.

A special type of circular sawing rig having three circular saws cutting in a vertical plane and one circular saw cutting in a horizontal plane, as diagrammatically shown in Fig. 61*a*, was devised to handle the large-sized timber on the Pacific Coast, especially redwood. The saws *A* and *B* were run only when the size of the logs required their use. The saws *C* and *D* were adjusted to cut in the same line, while saw *B* cut in a plane at right angles to saws *C* and *D*. Saw *A* cut in the same plane as *C* and *D* but 7 inches further in the log. The cutting planes of the various saws are shown in Fig. 61*b*. The breaking down of the log continued in this manner until it was reduced to a size which could be worked by the saws *C* and *D*.

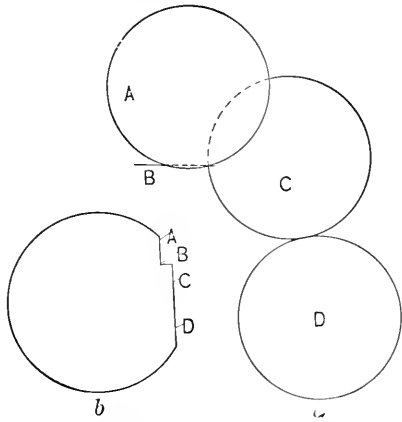

FIG. 61.—Saw Arrangement and the Cutting Planes of a Circular Breaking-down Saw. *a*. The Diagrammatic Arrangement of the Saws *A*, *B*, *C*, and *D*. *b*. Cutting Planes of the Saws.

The effectiveness of this equipment varied with the size of the log, a very slow feed speed being required when all four saws were used, otherwise the saws would tend to “lead” into the log. The average capacity of a mill of this character sawing redwood was 45,000 board feet daily, although when logs over 7 feet in diameter were handled the cut was less. This style of breaking-down equipment has been displaced by large band mills which are more efficient.

### Band Mills.

These are built both in single-cutting and double-cutting types, that is, they may cut only on the forward run of the carriage—single-cutting, or the saws may be toothed on both edges and cut both on

<sup>1</sup> See Fig. 60, for the general character of the equipment.

the forward and rear travel of the carriage—double-cutting. The first type is far more extensively used than the latter.

*Early Types.*—The idea of using an endless saw of the band type for cutting logs into lumber occupied the minds of lumbermen as early as the “sixties” of the last century. During this decade a mill built on this principle was brought to Philadelphia from France. In 1865 a firm in Fort Wayne, Ind., had a band mill in operation which had 5-foot wooden wheels with rubber faces. The upper and lower wheels were supported on a single vertical wooden post to which the bearings and accessories were attached. Saws 5 inches wide were used which were imported from France because satisfactory ones had not been produced in this country. This firm<sup>1</sup> manufactured and sold a number of mills modeled after the one in their own plant, substituting an iron post for the wooden one used in the first models.

A number of other types of band mills were brought out by various firms from 1883 on, most of them having rubber faced, wooden wheels of small size. The use of rubber faces was considered essential to the successful running of a saw over the wheels. Lumber cut by the early band mills was not well received in the markets, because much of it was poorly manufactured. Some dealers even refused to handle band-sawed lumber.

One defect of all early types of band mills was that of overhanging wheels, that is, the weight of each wheel was supported on one bearing only. This type was early discarded in favor of one with both ends of the wheel shaft supported on bearings. Another feature of the early mills was a contrivance designed to prevent the saw dragging on the log when the carriage was giggered back. At the present time this is accomplished by the carriage offset.<sup>2</sup> In the early mills they endeavored to overcome this difficulty by several appliances, one of which was a “depressor,” a device which moved the upper and lower saw guides sidewise and forced the saw away from the log. Another device had two small friction rolls behind the saw in place of the usual saw guides. The saw was forced out to the saw line by means of these rolls, and when the carriage was giggered back the pressure on the rolls was released and the saw fell back from the face of the log. Both of these ideas were early abandoned because they were hard on the saws, and the rolls were extremely noisy.

One of the interesting types of mills brought out in 1886 was the Cunningham inclined band mill. The mill frame sloped to the rear about 20° from its base so that the saw would enter the cut at approximately the same angle as a circular saw instead of straight down as in the present style of band mill. The mill did not prove to have any

<sup>1</sup> Hoffman Brothers, Fort Wayne, Ind.

<sup>2</sup> See page 61.

advantages over the standard type, but on the contrary had one disadvantage, namely, that in changing saws several more men were required. The manufacture of this style of mill was abandoned shortly after its introduction.

In the fall of 1887 a sawmill-machinery inventor took out patents on a band mill based upon the general lines of those now in use. The band saw grew in favor rapidly from this time and by 1889 several had been installed in sawmills in the Lake States region.<sup>1</sup>

*Single-cutting.* — Single-cutting band mills are built for sawing timber ranging from small second-growth logs up to the mammoth redwood logs of the Pacific Coast. The chief difference in mills adapted for cutting this wide range of sizes is in the diameter of the wheels and in the dimensions of the saw blade. A modern type of left-hand band mill is shown in Fig. 62. The mill has a heavy cast base and frame upon which are mounted the two wheels over which the band saw travels, the necessary devices for raising and lowering the top wheel, and the top and bottom saw guides. Both wheels are of the same diameter and range in size from 5 feet, in the smaller pony-band mills, to 10 feet in the Pacific Coast type of mills. Single band mills are built to operate with saws from 6 or 7 inches wide on a 5-foot wheel to 16 inches wide on a 10-foot wheel. Power for driving the saws is applied to the shaft on which the lower wheel is hung, the latter being weighted on the rim so that it serves as a balance wheel.

<sup>1</sup> For cuts and descriptions of some of the early types of mills, see *The Evolution of Modern Band Mills for Sawing Logs*, by C. Clint Prescott, The Prescott Co., Menominee, Mich., 1910.

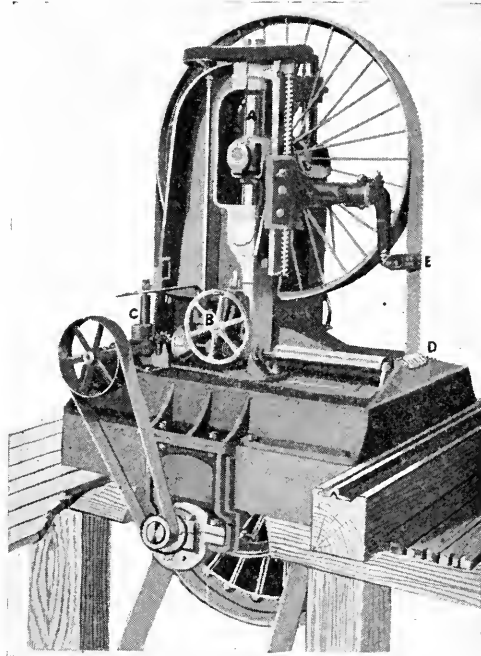

By permission Clark Bros. Co.

FIG. 62.—A Modern Left-hand Band Head-saw. A. One of the Vertical Columns which support the Upper Wheel Bearings. B. Hand Wheel for raising and lowering the Vertical Columns supporting the Upper Wheel Bearings. C. Tension Lever Weights. D. Lower Saw Guide. E. Upper Saw Guide.

The upper wheel is mounted on adjustable bearings, so that it may be lowered for removal of the saw, and raised to tighten it. The vertical columns *A*, Fig. 62, support the upper wheel bearings and are in turn supported at the base on knife-like bearings. The upper bearings are so adjusted that the top wheel may be tilted in order to align it properly with the lower wheel.

The vertical columns are raised or lowered by hand-driven or power-driven gears. The style shown in Fig. 62 is hand operated by means of the wheel *B*. Tension on the upper columns is applied to the knife-like bearings by a system of weighted levers, the weights of which are shown at *C*. The purpose of this tension adjustment is to allow a slight downward thrust to the bearings of the top wheel when an undue strain is placed upon the saw, thus relieving the tension and avoiding saw breakage.

The rims of the wheels may be either flat or slightly crowned, there being a difference of opinion among filers as to the relative merits of the two forms. A slight crown is sometimes used when high tension is carried in a saw while a flat face may be used with low tension. The flat face is more widely used to-day than the convex face.<sup>1</sup>

The bottom saw guide is shown at *D* and the upper guide at *E*. The latter is attached to a movable arm which may be raised or lowered, by a belt-driven screw, to accommodate the size of log or cant on the carriage. The saw guide is kept just above the top of the log or cant, thus steadying the saw where it enters the cut and preventing undue vibration.

The ability to raise and lower the upper wheel permits latitude in the length of saws used and the size of logs which can be sawed.<sup>2</sup>

Band-saw wheels are usually run at a speed of from 10,000 to 12,000 linear feet per minute, the number of their revolutions, therefore, varying with their diameters.

The power required to drive a band mill depends upon the amount of work which it is called upon to perform. When the mill is running free it is lowest and when deep cuts are being made it is greatest. The requirements for a mill without a load are about 50 horsepower, while the maximum load may be as high as 400 horsepower. Records of mills driven by electrical power indicate that a mill with an 8-foot wheel requires a motor capable of developing from 100 to 150 horse-

<sup>1</sup> The merits of the two forms of wheel faces are discussed in the *Wood Worker*, Indianapolis, Ind., March, 1909, page 28; April, 1909, page 27; and June, 1909, page 27; also in the *Canada Lumberman and Wood Worker*, Toronto, Ont., Jan. 15, 1912, page 33.

<sup>2</sup> Table XLVI, giving some of the data for the type of mill shown in Fig. 60, may be found in the Appendix, page 510.



power; a 9-foot mill, 200 horsepower; and a 10-foot mill, 300 horsepower. Band mills are usually belted to the motor instead of being directly attached to it because the load is not constant.

The output of a band mill depends on the size of the logs handled, their character, and the class of material manufactured. It is possible to saw more softwoods than hardwoods in a given time, because with the former the mill will stand a heavier feed. In southern yellow pine, an 8- or a 9-foot band head-saw will cut daily from 45,000 to 60,000 board feet of 1- and 2-inch stock. There are records, however, which claim daily cuts of 120,000 board feet, but in the latter case, a large part of the cut was thick stock. In hardwoods, the daily output seldom exceeds 35,000 or 40,000 board feet. A test run on selected white-pine logs running 1.97 logs per thousand showed an average output, in one shift, of 169,651 board feet of 1-, 1¼- and 2-inch stock.<sup>1</sup>

*Pony Mills.*<sup>2</sup>—Pony band mills do not differ in essentials from the type just described. They are light mills, usually with wheels from 5 to 7 feet in diameter, which are used in semi-portable and other plants to cut small logs. However, they are not an important feature in small milling operations, because of the higher first cost as compared to a circular mill, the necessity for the exercise of greater care in setting up the machinery, the greater weight which must be moved when a new set-up is made, and the need for more skillful filers. When there is less than one million feet of timber to be sawed at one place, the circular mill is preferred to the pony band. The daily capacity of a pony band mill when used as a portable rig seldom exceeds 13,000 board feet. When used as a permanent mill the daily cut may reach 20,000 or 25,000 board feet. Thirty-five or more horsepower is required to drive such a mill.

*Double-cutting.*—Double-cutting band mills were first put into practical use in 1898. They are much less extensively used than the single-cutting type and are best adapted for cutting 1-inch stock from logs which are uniform in quality. Where logs vary greatly in quality and many different sizes of product are being cut, there is less chance of saving time by cutting on the backward run of the carriage.

The builders of the double-cutting band mills sought a marked increase in output, which they believed would be possible with a mill which would cut as the log traveled in both directions. The early

<sup>1</sup> This test run was made at the plant of the North Wisconsin Lumber Co., Haywood, Wis., on August 23, 1893.

<sup>2</sup> So-called pony band mills are used in some sawmills on the Pacific Coast to supplement the head-saw. They are smaller than the latter but have a complete carriage equipment and are used as a substitute for a sash gang mill to manufacture flooring strips, stepping, and 1-inch boards.

hopes in this respect were not justified, since the average output of a double-cutting band as compared to a single-cutting one, other things being equal, is not more than 20 per cent. The reasons for this are that the return speed of the carriage is slower when cutting than it is when being giggered-back without cutting, hence the cut cannot be doubled. The carriage must also be giggered back without cutting when a log has to be turned after the forward cut, since the log-turning devices are placed only on the deck side of the carriage run. Some disadvantages which are common to double-cutting bands are that it takes a very skillful filer to keep the saw in first-class condition and unless it is accurately fitted it manufactures poorly sawed lumber. Errors in cutting are doubled as compared to a single-cutting band; that is, if the saw has a tendency to lead too much into the log on the forward run of the carriage it will reverse this process on the rear run, thus producing boards thin on one end and thick on the other. In general, the per cent of miscuts made by a double-cutting mill is in excess of those made on a single-cutting mill.

When a double-cutting mill is used it is necessary to make provision for handling the lumber cut on the rear travel of the carriage, since

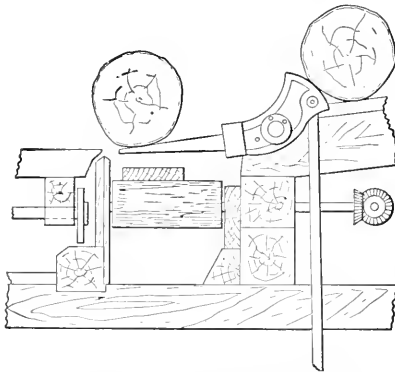

FIG. 63.—A Log-stop and Loader for a Double-cutting Band Mill. The Position of the Rollers which carry the Boards from the Deck-side to the Rear-side of the Band Mill are also shown.

the board must be dropped between the carriage and the deck. This is accomplished by a set of live rollers, placed between the log deck and the carriage, which carry the boards forward between the band mill frame and the saw to the line of live rollers which carry the boards toward the tail of the mill. A special type of log-stop and loader is necessary in order that the live rollers may be covered when a log is to be moved from the deck to the carriage. Fig. 63 shows the position of the arms when the log is passing over the rollers. As soon as a log is loaded on the carriage, the long arms assume a vertical position,

thus leaving the roller pit open so that boards may be dropped into it. This form of log-stop and loader is operated in the same manner as those shown in Fig. 25, *G* and *H*.

One of the types of double-cutting band mills is telescopic, the frame and working parts being attached, at the base, to the piston of a steam and oil cylinder arranged in tandem, Fig. 64. The steam cylinder

raises and lowers the framework which is held in position by means of the oil which is locked in the oil cylinder when the steam is cut off. The framework is held in alignment by vertical slides. The advantages claimed for the telescopic mill are that the upper wheel can be brought close to the top of the log being sawed, which gives a short rigid blade above the saw cut. These functions are performed in other types by a guide arm.

*Twin-bands.*—Twin-band saws have been installed in a few mills on the American continent to slab small logs for a circular-gang or a sash-gang. The chief object is to relieve the main band head-saws from handling small logs, thereby increasing the daily output of the mill. A twin-band mill has two band mills of special design, one right-hand and one left-hand, the frames of which are superimposed opposite each other, on a base on which they can be moved simultaneously back and forth and the distance

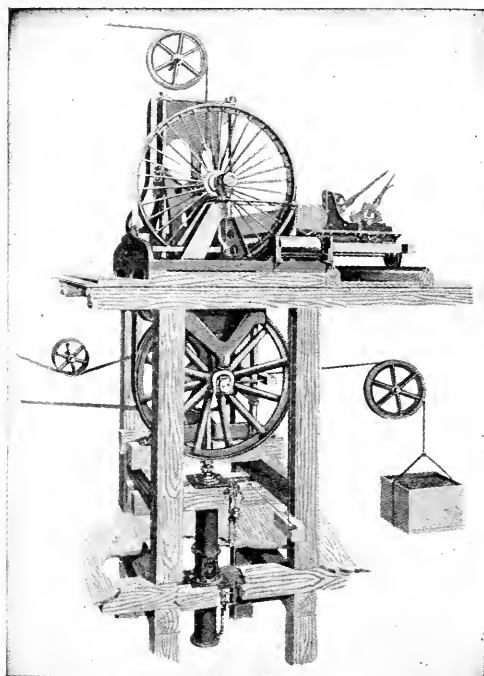

*By permission Allis-Chalmers Mfg. Co.*

FIG. 64.—A Telescopic Double-cutting Band Mill.

between saws increased or decreased. The range of distance between the saw lines may vary from 3 to 24 inches, although usually it is from 3 to 12 inches. The mills are equipped with saws about 10 inches wide and have small wheels, often not more than 5 feet in diameter.

A log carriage is not used. The logs are fed against the saws either by an endless chain with log dog attachments or by a steam feed. The latter has a feed cylinder placed on the front side of the band mills and another cylinder placed at their rear. A chuck which holds the log is attached to the ends of the piston rods of each of these cylinders.

The logs are brought to the deck in the usual manner and are rolled down into a V-shaped trough which leads to the band mill. The piston from the feed cylinder is then shot forward, and the log

clamped at its ends by the chucks of the two pistons. Driving the feed piston forward forces the log past the saws, which cut a slab from either side. The cant is then released and thrown out of the trough, the feed piston brought back to its original position, and the process repeated. The cylinder feed is preferred to the chain feed because the logs are held more firmly and when the saws strike a hard knot the log does not turn. The rated capacity of a mill of this type is from 1200 to 2000 logs per shift, and for the chain drive from 800 to 1500 logs.

*Self-contained Band Mill.*—A type of self-contained portable band mill which was placed on the market a few years ago is shown in Fig. 65. This mill differs from the usual types in that the log remains

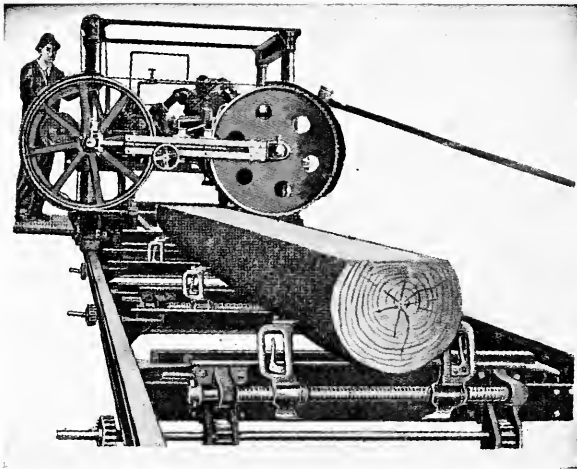

FIG. 65.—A Horizontal Double-cutting Portable Band Saw with a Traveling Saw Frame.

immovable on the log-bed while the saw equipment travels back and forth during the sawing operation.

The machine is of the horizontal band type, with 4-foot wheels. The mill is driven by a 25 horsepower steam engine mounted on the framework, steam being supplied from a 50 horsepower stationery boiler, through flexible pipe couplings. The saw cut is made from the upper side of the log, the thickness of the cut being regulated by raising or lowering the sawing apparatus by means of pinions which mesh into racks on four supporting posts. The feed is of the rack-and-pinion type, power being furnished by a 5 horsepower engine mounted on the framework.<sup>1</sup> The saws are 19 gauge, 7 inches wide, and double-

<sup>1</sup> Another mill, similar in form, which was put on the market in 1921, is equipped with a cable feed.

toothed, being designed to cut both on the forward and rear travel of the carriage.

Stock mills having a 28-foot log bed will handle logs of a maximum diameter of 44 inches, and a maximum length of 20 feet. The rated capacity of the mill is from 1000 to 1500 board feet per hour. This mill is offered as a substitute for portable circular mills on the basis that it will saw lumber of any thickness from veneers to timbers with a minimum waste of raw material and can be set up more readily than other small ones because the entire equipment is mounted on a truck of special design which can be quickly moved from one point to another.

### RESAWING MILLS

Resaws are designed to convert cants or timbers into smaller sizes, to split plank into 1-inch stock, or to work down heavy slabs which have come from the head-saw. Several distinct types of mills may be grouped under this head, namely, sash gang mills, band resaws, both vertical and horizontal, and circular gang mills.

#### The Sash Gang.

One of the smaller sizes of a widely used type of sash gang mill<sup>1</sup> is shown in Fig. 66, and has an oscillating sash or frame *A* carrying the saws, and actuated by the pitman *B*; a sash oscillating mechanism *C*; a feed roll *D*, with its friction drive and gearing shown on the right; and broken press rolls *E*, raised and lowered by means of a screw *F*, and the miter gears. The base of the gang mill rests on a foundation under the sawing floor which comes flush with the frame at *G*. The saw is brought into contact with the timber at the beginning of the downward stroke by means of the oscillating device *C*, while at the beginning of the upward stroke the sash swings backward, freeing the saws from the face of the cut.

The Wickes gang is built in seven different styles and in a variety of sizes to accommodate the various kinds of work which a gang mill may be called upon to perform.

The so-called stock-gang type is built with a distance between sash stiles of from 34 to 60 inches, and is designed to cut any depth up to 24 inches. The type shown in Fig. 66 is used for cutting flooring, ceiling and siding cants and has a distance between stiles of from 26 to 32 inches, and will cut any depth up to 8 inches.

The press rolls on the smaller sizes of gang mills are hand-operated, while on the larger mills they are raised and lowered by means of a

<sup>1</sup> The model shown is a Wickes No. 5 gang mill.

vertical steam cylinder, the piston of which is attached to the sliding frame on which each roll is hung. They are hung in a frame attached by hinges to the framework of the mill, so that the frame can be swung to one side when the saws are changed, and they are broken in order to allow cants of varying thickness to be fed through each side of the mill.

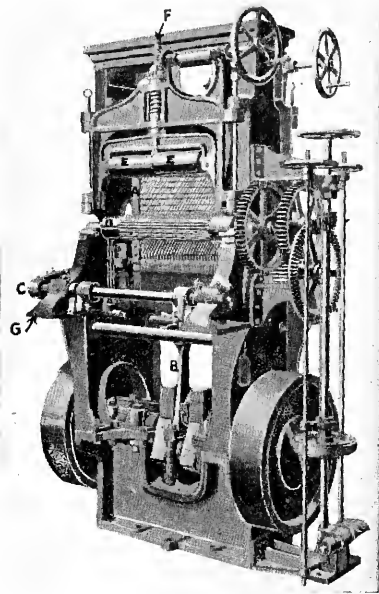

*By permission Wickes Bros.*

**FIG. 66.**—A No. 5 Wickes Sash-gang Mill.

- A. Oscillating Sash carrying the Saws.
- B. Pitman which actuates the Sash.
- C. Oscillating Device. D. Feed Roll.
- E. Press Rolls. F. Press Roll Raising and Lowering Mechanism.

The saws in the sash of a gang mill are usually spaced to cut 1-inch lumber, although the two outside saws may be spaced to cut 2-inch stock from the edges of the cants. The sash has lug attachments both at the top and bottom for each saw blade. The saws have a tab attached both at the top and the bottom of the blade and these tabs are inserted in the lugs, which serve to hold them in position. The saw blades are stretched by means of wedge-shaped steel pins which are inserted in a slot of the upper lug and are then driven taut by a hammer. The number of saws per sash varies from 18 to 60.

Cants are slabbed on one or more sides by the head-saw and are stored on sloping decks in front of the gang mill, and are later placed upon a set of power driven live rollers which carry them to the saws, and over the fluted drive roll *D*. The press rolls are then dropped on top of the cants, and the log is drawn forward against the saws. A similar set of feed and press rolls is mounted on the opposite side of the machine and aids in drawing the log forward as soon as the front end has passed through the saws.

The gang saw, in a modern mill, is located in the center of the sawing floor between the head-saws and the edger, sufficient space being left to furnish ample storage for cants in front of the gang mill and for sawed lumber behind it. Although much of the lumber cut from cants which have been slabbed on two or more sides will be square-edged when it leaves the gang, all of it is usually passed through the edger, the waney boards being made square-edged and the other

boards ripped into narrower widths when by so doing the grade of the lumber can be raised.

The number of strokes of the gang mill varies from 225 to 300 per minute, and the rate of feed per stroke ranges from  $\frac{5}{8}$  to  $1\frac{1}{8}$  inches, although the average feed does not exceed  $\frac{7}{8}$  inch in an ordinary run of logs. The power required varies with the size of the gang mill, and ranges from 100 horse-power for the smallest types to 300 horse-power for the largest.

The output per day for a gang mill depends on the number of saws in the sash, the size of cants, and the regularity with which they are fed to the saw. The average daily output for a No. 1 gang mill is from 50,000 to 60,000 board feet.

Gang mills are especially serviceable in sawmills which cut large quantities of stock boards for the lumber is well manufactured and can be produced cheaper than on a head-saw because the output per man is greater and fewer high-priced workmen are required. However, when defective logs are being sawed, each cant is reduced to boards irrespective of the location of defects, and consequently the grade of lumber secured from inferior logs may be lower than could be secured by sawing them on a head-saw and turning them on the carriage as often as necessary to secure the highest possible quality of lumber. Small logs can be handled in a gang mill cheaper than on a head-saw because of the lower labor cost.

During the period of rapid expansion of the lumber industry, and previous to the introduction of the band saw, various types of gang mills were devised as substitutes for the circular head-saw because they would produce more lumber and cut a smaller kerf. One of the combinations found at large mills was a slabbing gang and a stock gang. The former had two or three saws on each side of the frame and was used exclusively to slab logs for the stock gang which had a full complement of saws, and reduced the cants to lumber. The above combination, now rarely seen, was used thirty or more years ago in mills in eastern Canada, New England, New York, Pennsylvania, and occasionally in the Lake States.

A so-called "Yankee gang" also was used. This had a wide sash, one side of which carried slabbing saws only, while the other side had a stock-gang saw arrangement. The teeth of the two sets of saws faced in opposite directions. A log would be run through the slabbing side of the sash, while a cant passed through the stock side traveling in the opposite direction. The sash worked up and down in vertical slides and did not have the oscillating movement which to-day is in use in the standard type of gang. The logs and cants were carried on a special type of carriage which was fed by a rack-and-pawl arrange-

ment. This machine was not a success because of the heavy strain which was put upon the gang mill. The idea was abandoned years ago, although it is reported that they could be seen in operation in the United States as late as 1892.<sup>1</sup>

### The Vertical Band Resaw.

The vertical band resaw is often used in large mills to supplement the main sawing equipment, planks or cants being cut on the head-

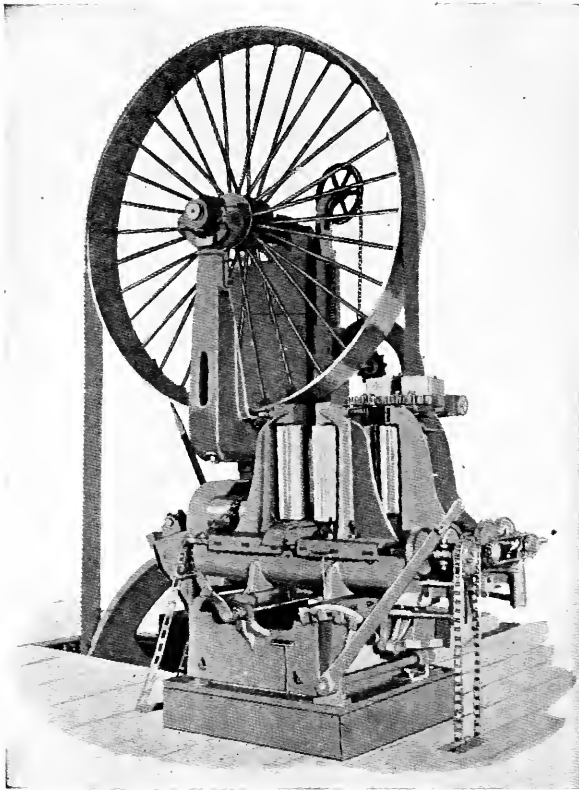

*By permission McDonough Mfg. Co.*

FIG. 67.—A Vertical Band Resaw for Sawmill Use.

saw and sent to the resaw to be split into thinner pieces. Resaws of this type also are used in planing mills for resawing stock, but these machines are lighter than those employed in sawmills.

One type of a vertical resaw for sawmill use is shown in Fig. 67. It has the same mechanism as a band head-saw for supporting the

<sup>1</sup> See American Lumberman, Feb. 1, 1902, page 184.



wheels and tightening the saws. The planks or cants are placed either in a trough and fed against the saw by means of a flat endless chain, or they are placed on live rollers which carry them forward, hence a log carriage is not required. The feed works on a vertical resaw comprise two pairs of power-driven pressure rolls hung on vertical axes, which draw the boards or cants past the saw. The distance between rolls can be varied to suit the size of material being handled. Set-works are provided so that any desired thickness can be cut from one side of the stock.

When the stock is split once only, as is often done, the lumber, after leaving the resaw, passes on live rollers to the edger. When a cant is to be split into several pieces it is necessary to provide a return roll system by means of which the cant can be brought from the rear to the front of the resaw. The location of the resaw on the sawing floor of a single head-saw mill and the system of return rolls for a cant sawing resaw are shown in Fig. 68. The cants as they leave the head-saw pass down the live rollers and are shunted upon the transfer *A*. They are then carried to the live rollers leading to the resaw by the transfer chains. After passing through the resaw, the board is thrown to transfer *B* going to the edger and the cant is thrown upon transfer *C*, up which it passes to the live rollers, which carry the cant toward the front end of the mill, where it is tripped off upon transfer *D*, which carries it back to the rolls leading to the resaw. A cant travels around the return-roll system as many times as is necessary to reduce it to the desired thicknesses.

The feed speed of a vertical resaw is variable, ranging from 80 to 250 linear feet per minute. The daily output of a large vertical resaw is dependent largely upon the constancy with which planks or cants are fed into it. When kept operating to capacity a vertical resaw will split from 150,000 to 200,000 board feet of 2-inch planks into 1-inch boards in a ten-hour shift. An 8-foot resaw requires from 100 to 150 horse-power to drive it.

The chief advantage of a vertical resaw in a mill is that the output of the mill can be increased at a relatively low cost per thousand board feet. The head-saw, by cutting thick stock, can handle a greater number of logs and resawing on a vertical resaw can be done cheaper than on a head-saw because a smaller crew is needed, and with the exception of the sawyer, the laborers may be unskilled.

A twin-band vertical resaw is sometimes employed for planing mill service where thin box material is desired. This type has two sets of wheels mounted tandem on one frame, both saws being fed by the same feed rolls. It is equipped with a device by means of which the distance between saws can be varied, in order to cut stock of different thickness.

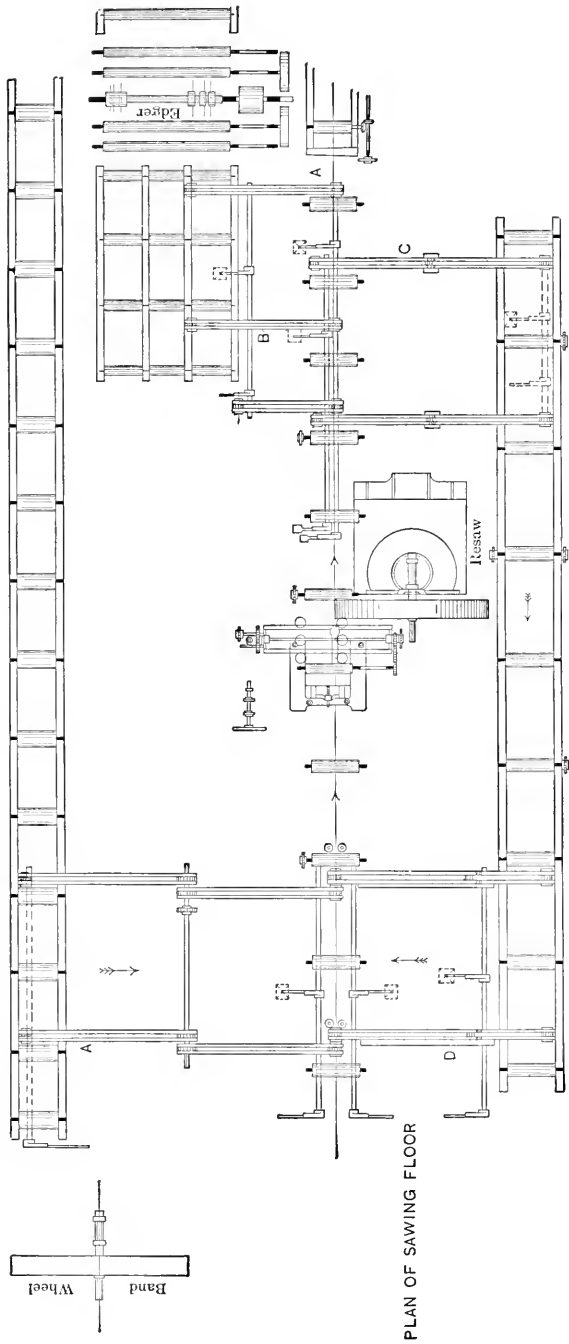
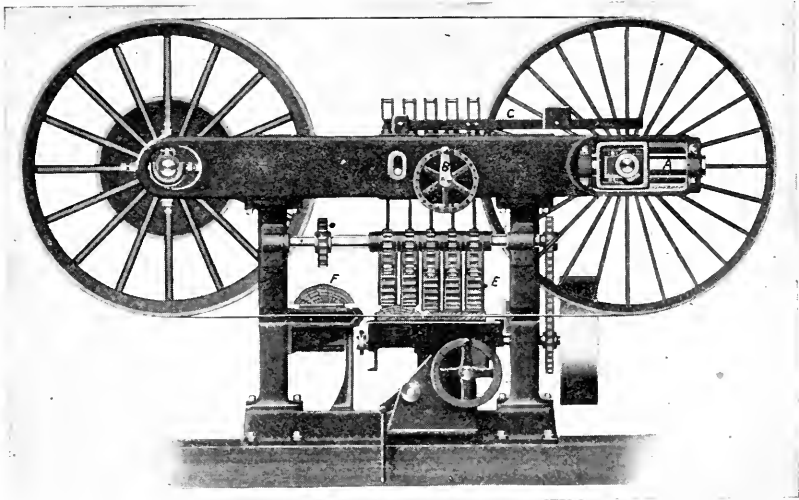

FIG. 68.—A Return Roll System for a Vertical Resaw. A. Transfer from the Main Line of Live Rollers to the Storage Skids. B. Board Transfer to the Edger Table. C. Transfer to the Line of Live Rollers which carry Cants from the Rear to the Front of the Resaw. D. Transfer from Live Rollers to Storage Skids in Front of the Resaw.

A battery of vertical band resaws is used in some Pacific Coast mills, any number of saws up to six being arranged one behind the other, each saw being a separate unit, but so mounted that a lateral adjustment can be made which makes it possible to saw stock of different thicknesses.

### The Horizontal Band Resaw.

The horizontal band resaw is used most frequently in planing mills for resawing short stock and also in sawmills to resaw heavy slabs and small logs which have been split by the head-saw. One make of horizontal resaw is shown in Fig. 69. In the type illustrated,



*By permission Clark Bros. Co.*

FIG. 69.—A Horizontal Band Resaw for Sawmill Use. *A.* Post which supports the movable Wheel Bearings. *B.* Tension Wheel. *C.* Tension Lever Arm. *E.* Press Rolls. *F.* Return Rollers for Slabs.

the framework supports the two wheels, which are built either 66 or 84 inches in diameter. The left-hand wheel, the driver, has a fixed position, while the posts *A*, to which the bearings for the right-hand wheel are attached, may be moved in or out when the saw is to be loosened or tightened. This movement is accomplished by means of the hand wheel *B*, on the shaft of which there is a pinion which meshes into a rack on the bearing post. Additional tension is applied to the ends of the posts by means of the weighted lever *C*. The slab rests on a feed table which may be raised or lowered to cut different thicknesses of lumber. The table is equipped with four power feed

rolls which raise and lower with it. The upper press rolls *E* are several in number so that they may adjust themselves to all thicknesses and irregularities of the stock. The slabs are fed face down against the saw, and the board is cut from the under side as shown in the figure.

Resaws of the type shown in Fig. 69 will handle any number of slabs the total width of which does not exceed 36 inches. The return space at *F* is 26 inches wide, although this can be increased to 36 inches by raising the press rolls. The stock is returned to the rear of the resaw by means of a set of rollers, as shown at *F*. With some other types the return system shown in Fig. 68 is used.

The feed speed of a horizontal resaw varies from 100 to 250 linear feet per minute. They increase the daily output of a two-band mill from 35,000 to 60,000 board feet, by allowing the head-saws to cut heavy slabs and also by sawing up small logs which have been split on the main saws. Horizontal resaws, as a rule, do not manufacture as perfectly sawed lumber as the head-saws, the tendency being to cut boards too thick at some points and too thin at others. Their chief advantages are that few men are required to operate them and only the resaw sawyer must be a skilled operator. An 84-inch resaw requires approximately 100 horse-power to drive it.

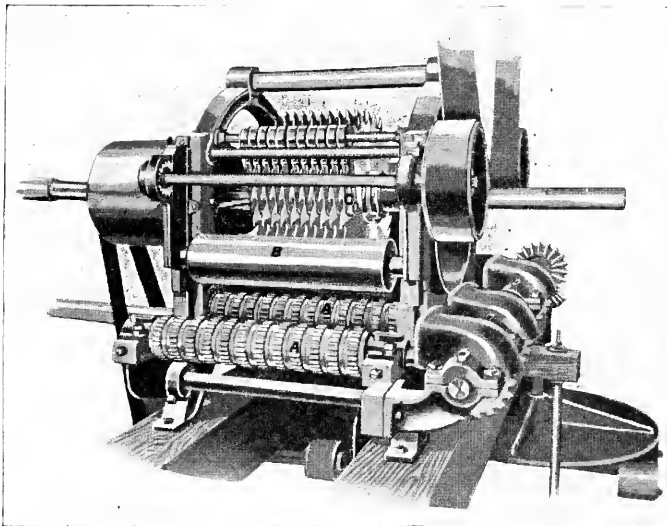
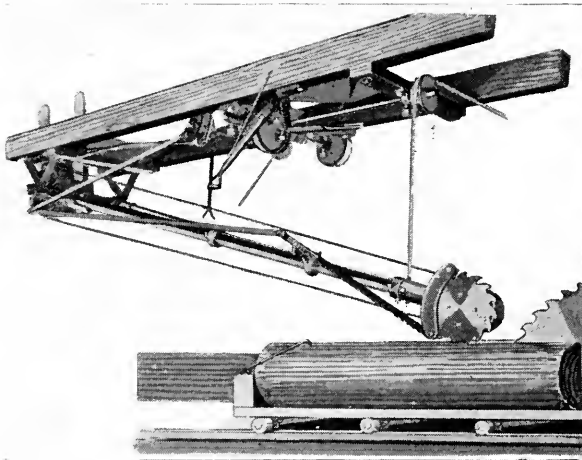

FIG. 70.—A Circular Gang Mill. A. Feed Rolls. B. Press Rolls.

### The Circular Gang Mill.

This type of mill, sometimes known as the rift or the strip circular gang, has a battery of circular saws from 22 to 26 inches in diameter,

mounted on a single arbor and so spaced that 1- or 2-inch stock, usually the former, may be cut from cants, 8 inches or less in thickness. The equipment may be an independent machine with suitable feed rolls and press rolls, or the saws may be mounted on one end of the shaft of a gang edger. A circular gang mill may be used in sawmills which do not have a sash gang mill, but which produce a limited quantity of flooring and other strips, especially in 4- and 6-inch widths. It was formerly used in the northeastern part of the United States and in eastern Canada for resawing cants made from logs from 6 to 15 inches in diameter, but it has been replaced to a large extent by some form of band resaw or by a small sash gang cutting a smaller kerf. The circular gang usually is fitted with inserted-tooth saws, which are run at from 1600 to 2200 revolutions per minute. The feed speed is variable, the maximum being 1 inch per revolution of the saw. The rated capacity of a machine sawing 6-inch cants of a width which will produce from nine to ten boards per cut is from 8000 to 10,000 board feet per hour. One type of circular gang is shown in Fig. 70. The power required to drive a circular gang depends on the number of saws and the size of the cants, the range being from 50 to 100 horse-power.



*By permission J. A. Weber Co.*

FIG. 71.—A Rock Saw used to clean the Upper Side of Logs which have been transported by Water.

#### ROCK SAW

An accessory to the head-saw in some mills cutting timber which has been floated is a rock saw. A common type has a small inserted-tooth circular saw which is suspended by means of a long arm from a beam over the carriage and in front of the head-saw. The arm may

be raised and lowered as necessary to enable the rock saw to cut on the top side of a log of any diameter. It is driven by a belt, and often is enclosed in a hood so that the sawdust can be drawn away from the saw line by suction and discharged into a dust-collecting system.

The rock saw is suspended 2 or 3 feet in front of the head saw, and cuts a  $\frac{1}{2}$ -inch kerf through the bark on the top of the log, and by so doing removes gravel, mud, ice, grit and other material, which would dull the head-saw. It is of service in indicating the presence of iron rafting dogs, which, if undetected, might seriously damage the head-saw.

The rock saw is elevated above the log after the latter has been slabbed, since it is used only when slabs are being removed. A planer cutter-head is sometimes substituted for the rock saw, but its use is not common. Although the rock saw frame often is constructed at the mill plant, there are some patent devices on sale, one of which is shown in Fig. 71. A rock saw requires from 10 to 15 horse-power to drive it.

#### THE EDGER

The object of edging lumber is to make it square-edged and of standard width; to rip boards into narrower widths, either to raise the grade or to secure edge-grained flooring strips; and to rip cants into edge-grained stepping or some other similar product. Special edging machinery is seldom used in portable sawmills. Several boards are piled flat on the head blocks of the carriage and the lumber square-edged on the head-saw.

The lumber as it leaves the head-saw in a semi-portable or a permanent plant travels toward the "tail" of the mill, where it is passed through a machine, known as an edger,<sup>1</sup> which is equipped with one or more circular rip saws. Edgers are built in two types, namely, the single and the double, the latter having split feed rolls which permit two pieces of unequal thickness to be fed into the machine at the same time.

An edger has a front feed table equipped with dead rollers, Fig. 72 *A*; a framework carrying the arbor and saws; feed rolls *C*; press rollers *D*; and a rear table with power driven live rollers, which carry the boards away from the rear of the edger. The front table is equipped with side guides *B* and either with single or double rolls as required. It often is 12 feet in length and from 50 to 84 inches wide, between guides. The length of the rear table depends upon the length of lumber handled. In a mill sawing standard-length logs it is from 25 to 30 feet

<sup>1</sup> The location of the edger on the sawing floor of a sawmill is shown in Fig. 24.

in length. Where very long logs are handled the length must be increased accordingly. The framework of the edger proper is cast and supports the saw arbor, feed roll, press roll, driving pulleys and saw shifting devices.

The saws are mounted on an arbor which has two opposite rectangular-shaped lugs parallel to its axis and slotted ways on the saw collars fit over them. This method of mounting enables the edgerman to move the saws in a lateral direction when it is desired to increase or decrease the distance between them. The number of saws carried on the arbor varies from two to four on a single-gang edger fed by one man, and from six to eight saws on a double-gang edger fed by two men. One or two saws on the outer ends of the arbor are often stationary on medium-sized edgers. These saws are set either 4 or 6 inches inside of the side

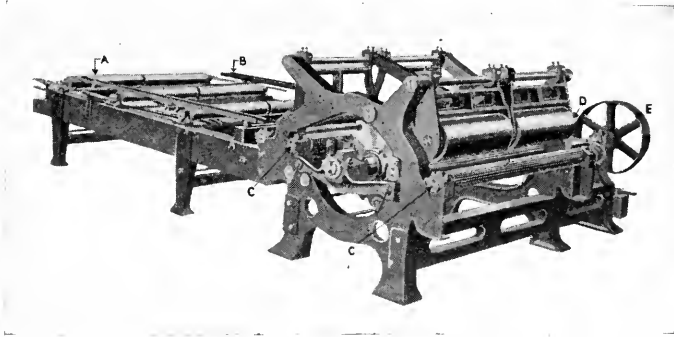

*By permission The Prescott Co.*

FIG. 72.—A Double Gang Edger. A. Front Feed Table. B. Side Guide. C. Feed Rolls. D. Press Rolls. E. Feed Roll Drive.

guides, so that when the latter are flush with the inner edge of the front table frame, a 4- or a 6-inch strip will be made. The remaining saws may be moved from side to side, coming within 4 inches of the stationary saws or of each other.

The movable saws are shifted in a lateral direction by means of a steel U-shaped guide, Fig. 73, which fits around the outer edge of the saw below the cutting line. These guides, which are equipped with renewable hardwood guide plugs, A, which steady the saw, are hinged in order that they may be thrown back out of the way when the saws are removed from the arbor.

The saw guide shown in Fig. 73, is mounted on a planed iron guide plate B, from 30 to 48 inches long which slides in planed ways. These guide plates are moved by a steel flat-link chain C, which is wound around the chain drum D on the end of the shifting rod E, the ends

of the link chain being fastened by eye-bolts at *F* and *G*. The shifting rod *E* passes below the rollers, to the front end of the edger table, where a hand wheel is attached to it, by means of which the edgerman rotates the rod. The wheel has a notched rim and a spring pawl which holds the guides in place. An index on the wheel indicates the distance between saws. The chain drum is replaced in some types of edgers by a pinion and the guide plate by a rack to which the saw guide is attached. A more simple form is shown in Fig. 74, in which the saw guide is directly connected to an individual lever. The levers on large edgers are hung on individual bearings.

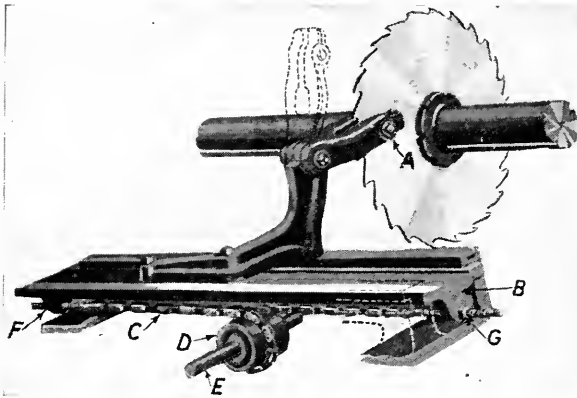

*By permission Clark Bros. Co.*

FIG. 73.—An Edger Saw Guide. *A*. Removable Hardwood Plugs. *B*. Iron Guide Plate. *C*. Flat-link Chain for moving the Guide Plate. *D*. Chain Drum for actuating the Chain *C*. *E*. Shifting Rod. *F* and *G*. Points of attachment of Chain *C*.

The edgers used in Pacific Coast mills differ from those previously described in that they are used both to edge lumber and to resaw cants. The front edger table is replaced by rollers between which transfer chains run which bring the stock from the line of live rollers leading away from the head-saw to a position in front of the edger. The edgerman stands directly in front of the machine and shifts the saws by means of short levers. The feed rolls on a machine of this type are raised and lowered by means of steam-driven pistons.

The fluted or spiked feed rolls on an edger, Fig. 72 *C*, are placed in pairs on large machines and singly on small ones and their diameter is about 6 inches. They are designed for feed speeds from 180 to 200 linear feet per minute, although a speed as high as 300 linear feet may be used on large Pacific Coast edgers. On some of the largest machines



they are driven by variable-speed motors, which enable the operator to use a lower speed when ripping large cants.

Feed rolls wear under constant usage and must be replaced or repaired, otherwise the rolls will not hold the boards firmly and the

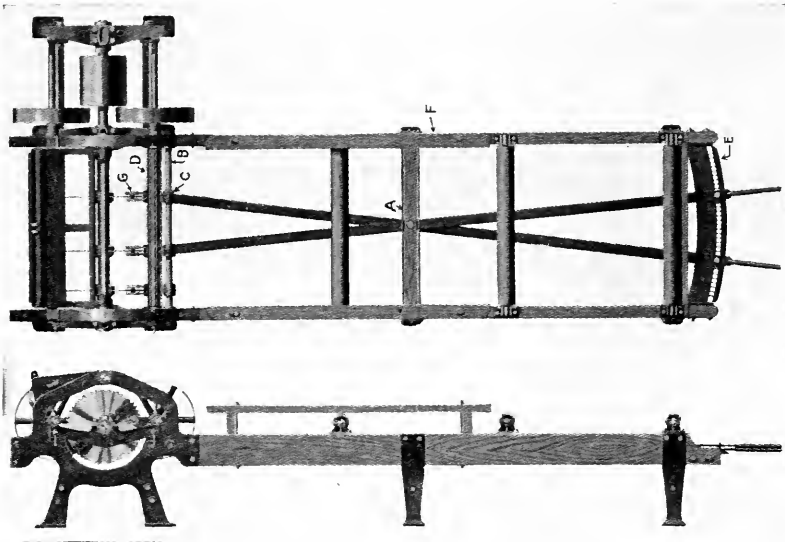

*By permission The Prescott Co.*

FIG. 74.—A Single Gang Edger. *A.* Pivot Point for the Saw-shifting Levers. *B.* Shaft on which the Lever Handles slide. *C.* Sliding Collar on Lever Handle. *D.* Feed Roll. *E.* Handle Stops. *F.* Side Guide. *G.* Saw Guide.

latter will dodge when the saws strike knots. The removal and repair of these rolls is expensive and frequently changes are not made as often as they should be.

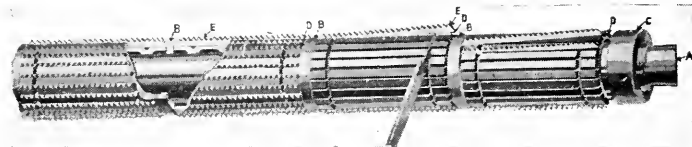

*By permission E. C. Atkins & Co.*

FIG. 75.—The Coleman Sectional Feed Roller. *A.* Feed Roll Shaft. *B.* Loose Collar. *C.* Screw Collar. *D.* Fluted Roll Sections. *E.* Removable Toothed Sections.

A type of sectional feed roller<sup>1</sup> designed to facilitate repairs is shown in Fig. 75. It has a shaft *A*, loose collars *B*, a screw collar *C*, fluted sections *D*, and toothed-sections *E*. The fluted sections *D* fit

<sup>1</sup> Known as the Coleman Feed Roller.

over the shaft and are separated by the loose collars *B*. The toothed sections *E*, made of hardened steel, are inserted in the fluted sections, the ends of the loose collars overlapping their base and holding them in place. The various sections are held in place on the shaft by the screw collar, *C*. To remove any of the toothed sections *E*, it is only necessary to unscrew the collar *C*, shift the fluted section *D* along the shaft until the loose collars can be moved away from the base of the toothed sections *E*, when the latter can be raised by a file point, then withdrawn and a new toothed-section inserted.

The press rolls *D*, Fig. 72, serve to hold the boards against the feed rollers and are not power driven. They vary in diameter from 5 inches in the smaller to 8 inches in the larger machines and are hung in a frame so that they can be raised in order to permit thick stock to be fed between the feed and press rolls. Press rolls have a plain face, since they have no driving power. The maximum depth of cut which can be made by an edger varies from 6 or 7 inches on medium-sized machines to 14 inches on the heaviest Pacific Coast type.

The capacity of an edger varies with the number of saws and size of material edged. A four-saw single gang edger is ample for a single band mill, but in a mill having two head-saws, a four-saw edger is provided for each head-saw. The addition of a gang mill to the sawing equipment of a double mill necessitates the use of one gang edger with four saws and another one with seven saws. The latter with two edgermen will handle the output from one head-saw and from the gang saw. A heavy type of double-gang edger is used in Pacific Coast mills even though only one head-saw is installed. The 10-hour capacity of double edgers varies from 75,000 to 300,000 board feet, depending upon the thickness and width of material. The medium-sized four-saw edger requires approximately 50 horse-power to drive it, while a large eight-saw Pacific Coast type, 12 by 72 inches, when electrically driven, is usually directly connected to a 200 horse-power motor.

#### THE TRIMMER<sup>1</sup>

Lumber usually is trimmed on the ends to make it of standard length and boards also may be cut into shorter lengths in order to eliminate defects and thus raise the grade.

Portable mills seldom are equipped with trimming machinery but semi-permanent and permanent mills always have such equipment. The simplest form of trimming equipment, adapted only for mills of very limited output, has a single circular cut-off saw, only one end of the board being trimmed at one time. Some improved form of trim-

<sup>1</sup> For the location of the trimming equipment on the sawing floor see Fig. 24.

ming equipment is required where the amount of lumber produced is 15,000 board feet or more. Such a trimmer has a table of sufficient length to handle the lumber. This table is equipped with endless chains which carry the boards past a battery of two or more cut-off saws.

A common type of two-saw or three-saw trimmer found in mills having a daily capacity of from 20,000 to 50,000 board feet is shown in Fig. 76. The position of the endless feed chains *A A*, Fig. 76, are fixed, while *B, B* with the saws, may be moved simultaneously away from or toward the center by means of the crank and chain attachment shown at *C* and *D*.<sup>1</sup> The shafts *E* and *F*, on which *B* and *B* are mounted, have opposite longitudinal lugs which fit into slots on the saw collar, the lateral action of the saws being similar to that on an edger arbor.

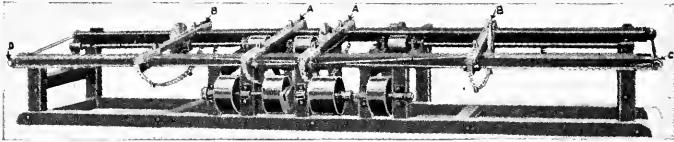

*By permission Clark Bros. Co.*

FIG. 76.—A Three-saw Trimmer. *A*. Fixed Endless Feed Chain. *B*. Movable Endless Feed Chains. *C* and *D*. Points of attachment for Cranks. *E* and *F*. Driving Shafts.

By the system of chains and connecting rods shown, a turn of the crank at *C* or *D* draws *B* and *B* either toward or away from each other. One revolution of the crank moves each saw 1 foot in a lateral direction. Machines of this type are usually built to trim boards ranging from 4 to 24 feet in length.

The endless chains, *A A*, are driven by sprockets attached to a shaft on the rear side of the trimmer, the sprocket wheels having collars with slots which fit over lugs on the driving shaft in the same manner as the slots on the saw collars fit over lugs on the driving shafts *E* and *F*.

The trimmer is loaded by two men, one at each end of the machine, the crank at *C* being operated by one of the loaders. A trimmer of this character usually does not require more than 10 horse-power to drive it.

The trimmer in a mill having a daily capacity of 40,000 board feet or more consists of a battery of circular saws arranged in a horizontal line and spaced 2 feet apart with the exception of the first and second saws on one end of the table, which usually are either 4 or

<sup>1</sup> This crank at *D* is omitted in Fig. 76, but may be attached if so desired.

6 feet apart, depending on the shortest board which is saved. The number of saws in a mill sawing standard-length logs generally is 12 or 14, while in those sawing long logs there may be 40 or more saws. The trimmer table is from 7 to 11 feet wide and 2 feet longer than

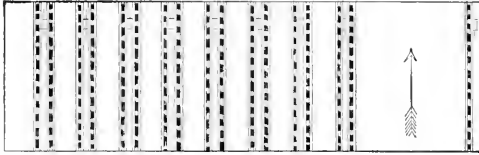

FIG. 77.—A Right-hand Trimmer Table showing the Saw-spacing and the Double Feed-chains.

the maximum length the saws will trim. The front of the table is approximately 28 inches and the rear about 39 inches above the floor level. It is equipped with endless chains and dogs, a chain running on either side of the saw as shown in Fig. 77 in order to prevent the board from turning at an angle and binding the saw. The saws may be hung from beams above the table and dropped as needed for cutting (overhead trimmer) or they may be hung underneath the table and raised up as needed (under-cut trimmer) The first type is in more common use.

The method of hanging overhead saws is shown in Fig. 78. The endless-chain driving mechanism is shown beneath the table, and the individual saw drive at *A*. The saw is raised and lowered by means of the rod *B*, which is operated from a box in front of and above the level of the trimmer table. The counter-weight *C* aids in raising the saw when the rod *B* is forced downward. The hand method of raising and lowering trimmer saws is in common use on trimmers of medium size, but often is replaced by a pneumatic system in heavy-duty trimmers which have a large number of saws. In a pneumatic system the weight usually is suspended from a lever-arm attached to the rear-end of the arm supporting the saw and the rod *B* is directly attached to the piston rod of a vertical, double-acting, 4-inch bore compressed-air cylinder placed directly overhead. The action of valves which admit compressed air to the cylinders is controlled by short levers in the trimmer leverman's box, each valve being directly connected by an air-feed pipe to an individual cylinder.

An electric control for an overhead trimmer was put on the market in 1921, and was designed to eliminate pull cords and rods on hand-operated machines, and valves, piping and pipe connections on compressed-air systems. A magnet is mounted above each saw frame, the latter having a rod connection with the magnet plunger.<sup>1</sup> The operat-

<sup>1</sup> The magnet consists of a coil of closely wound copper wire, through the center of which, a 2-inch steel plunger travels. The mechanism is enclosed in a cast-iron case 10 inches in diameter and 12 inches long, with a small compression cylinder for cushioning the up and down stroke of the plunger.

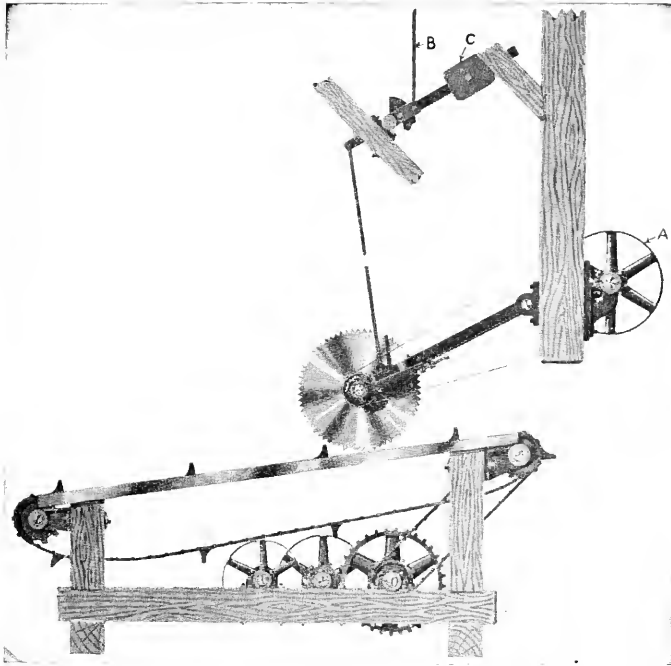

*By permission The Prescott Co.*

FIG. 78.—An Overhead Trimmer. A. Individual Saw Drive. B. Control Rod. C. Counterweight.

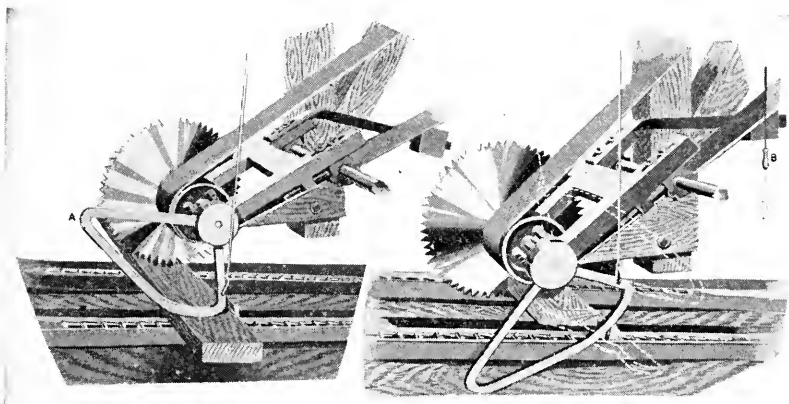

*By permission Clark Bros. Co.*

FIG. 79.—An Overhead Trimmer with Automatic Control. A. Quadrant for raising the Saw. B. Pull Cord for raising a Quadrant.

ing board has a series of key triggers, one for each saw, with a separate key trigger for applying power simultaneously to alternate saws, when the trimmer is used as a slasher. A twenty-saw trimmer requires a maximum of 15 horse-power.

An automatic device for overhead trimmers of the type shown in Fig. 79*a* and *b*, has a quadrant *A* attached to the arbor of each saw. The forward end of the quadrant in its normal position hangs below the saw table level and a board passing under it automatically raises the quadrant and saw above the board as shown in Fig. 79*a*, so that the saw does not cut. The saw remains in a cutting position when a quadrant does not strike a board, and will trim the fractional 2-foot length from the end of the board as shown in Fig. 79*b*. When a board is to be cut into two or more pieces the quadrant is raised, as shown in Fig. 79*b*, by pulling on the cord *B*, which allows the saw to remain in a trimming position. The table equipment for this style of trimmer is the same as for other overhead types. The advantage of this trimmer is that it may be operated by the trimmer loadermen and the services of a trimmer leverman is dispensed with. It is adapted for mills cutting 100,000 board feet or less in one shift, and for a maximum length of 26 feet.

In the under-cut trimmer the arms bearing the saw are suspended under the saw table, and when not in use the saws are below

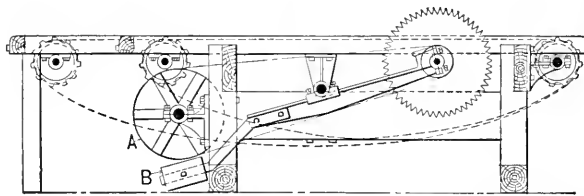

FIG. 80.—An Under-cut Trimmer Saw in Cutting Position. *A*. Drive Pulley. *B*. Counterweight. When the Saw is not in use it is dropped below the Table.

of the top of the table. One method of hanging under-cut saws is shown in Fig. 80, *A* being the driving pulley and *B* the counterweight. The saws may be raised by foot pedals connected to the arms supporting the saws, by hand levers, by compressed air or by magnets. When pedals are used, the saws are brought into a cutting position by one of the trimmer loadermen, while a trimmer leverman is required where hand-lever or air-control is used.

The foot-pedal control may be used in mills having a daily capacity of 60,000 board feet or less, while for greater capacities one of the other forms is necessary, because the loaderman cannot then perform both loading and control work. An under-cut trimmer may be used for a daily capacity of 150,000 feet when fitted with lever control.

The load demand on a trimmer lasts only for a very short period, therefore, the power is largely consumed in running idle saws. The

power demand varies from 15 horse-power for medium-sized to 50 for heavy-duty trimmers. The speed at which trimmer saws are run varies from 600 to 800 revolutions per minute.

THE SLASHER <sup>1</sup>

The slasher is used to cut slabs, edgings and other mill refuse into suitable lengths for firewood, lath stock, or for any other purposes for which such material may be used.

The slasher has a battery of saws arranged in a horizontal line, above a table up which passes the mill refuse which is to be cut into

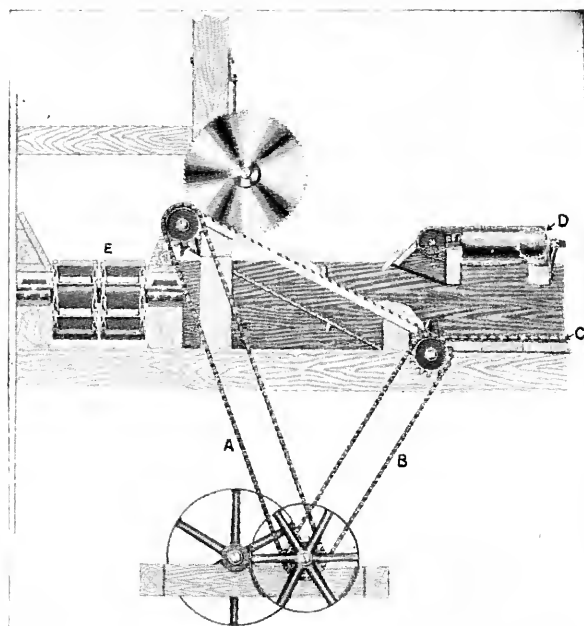

*By permission The Prescott Co.*

FIG. 81.—A Slasher. *A.* Drive for the Slasher Table Feed Chain. *B.* Drive for Conveyor Chain. *C.* Conveyor Chain. *D.* Line of Live Rollers. *E.* Refuse Conveyor.

shorter lengths. The arbors on which the saws run are attached to posts suspended from above so as to give a clear space below the saws, for the entire length of the slasher table.

A cross-section of a slasher is shown in Fig. 81. The chain *A* drives the feed chain on the slasher table; the chain *B* drives the conveyor chain *C*, which brings refuse from the opposite side of the mill; the

<sup>1</sup> For the relative location of the slab-cutting equipment on the sawing floor see Fig. 24.

live roller *D* brings refuse from the near side of the mill, and the refuse conveyor *E* carries the material away from the rear of the slasher.

The table is equipped with two conveyor chains for each saw in order that they will not bind in the cut, the saw line being midway between the two chains. Two saws usually are mounted on one shaft to facilitate their removal for sharpening, and each shaft is driven from above by an independent belt drive. When all saws are mounted on a common shaft the drive pulley is placed at one end of the shaft and is belt driven from below the sawing floor.

When slabs are used for lath manufacture, the saws are placed 49 inches apart which furnishes 48 $\frac{3}{4}$ -inch lath stock. Some of the saws may be spaced 16 or 24 inches apart if a portion of the refuse is marketed for firewood.

A 30 horse-power motor will drive a slasher having five 46-inch saws but a motor having from 50 to 75 horse-power may be necessary when there are ten or more saws. The speed at which the saws are run usually is from 900 to 1000 revolutions per minute.

#### WOOD REFUSE GRINDERS

Several types of machines are used for grinding refuse at sawmill plants, a common form being shown in Fig. 82. This has a heavy metal frame, enclosing a revolving disk *A*, on which are mounted the cutting knives *B*. The latter do not extend across the entire face of the disk, but are staggered so as to shear the full width of the anvil *C*. The size of chips is regulated by the distance the cutting knives *B* are set from the anvil *D*.

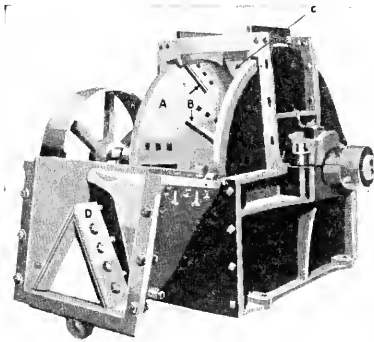

FIG. 82.—A Refuse Grinder for converting Sawmill Waste into Fuel. The Revolving Disk *A*, on which the Cutting Knives *B* are Mounted, rotates towards the Anvil *C* on which the Refuse rests as it is cut into Chips. The Cut shows the Grinder Case open. When in operation, the Hinged Cover shown in the Lower Left-hand Corner of the Cut is folded back against the Case and bolted to it.

Mill refuse usually is fed into the machine by hand through a chute terminating at *E*, although at some plants the conveyor dumps directly into the chute.

This type of hog is built in six different sizes having disks from 24 to 60 inches in diameter and carrying from twelve to thirty-six cutting knives. Some of the dimensions

and the rated capacity of this type of hog are as follows:



No. of Machine	Size of Disk, Inches	Number of Knives	Speed, r.p.m.	Horsepower Required	Rated Capacity, Cords per Hour
25	24×18	12	1500	25	8
35	34×22	16	1000	40	10
40	48×23	20	825	50	12
45	48×30	20	825	65	16
60	60×23½	28	650	75	16
65	60×38½	36	650	100	20

The "hog" is usually placed near the conveyor passing to the burner, and the "hogged" material falls into a conveyor and is carried to some point where it can be dumped into the conveyor system which goes to the fuel house.

#### REFUSE BURNERS

The use of some form of incinerating device for disposing of sawmill refuse, such as bark, slabs, trimmings, and edging strips is necessary when the fuel requirements of the plant do not demand all of the material or where a local market does not exist for it.

The quantity of refuse burned in former years, when close utilization was not practiced, was much greater than it is to-day. Some plants now find it possible to dispense with a burner, utilizing the refuse for various purposes, which at least repay the cost of handling.

There are two general types of burners in use, namely the open-pit and the enclosed.

#### Open-pit Burner.

The open-pit type of burner has a semicircular wire screen or brick fire-wall from 20 to 30 feet in height which is placed around the open fire on the side next to the sawmill building, Fig. 83. No provision is made for grates, the base of the fuel pile resting on the earth. The fire pit is sometimes surrounded by water as an additional measure of fire protection.

The refuse is brought from the rear end of the mill by an endless chain conveyor which is supported on a wooden or steel trestle and which usually runs at right angles to the main axis of the sawmill. When a wooden trestle is used that portion nearest the fire is made of metal plates and overhangs the fire, the end being supported by cables or braces which are attached to an overhead framework in the rear of the fire wall.

If possible, it should be located so that the direction of prevailing winds is away from the buildings. This type of burner is a greater fire hazard than an enclosed one, but it is more closely watched on that account and consequently the hazard is reduced. It is in common use at plants in rural sections where ample space is available for buildings, but it is not used in cities or in places where the buildings must be closely grouped.

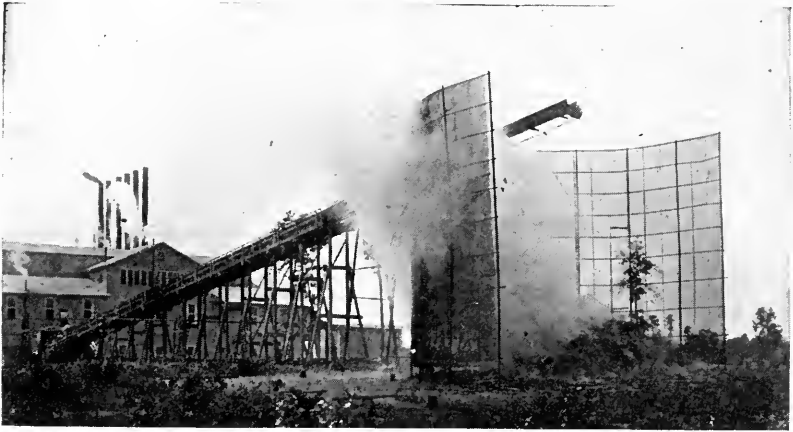

FIG. 83.—An Open Refuse Burner with a Wire Screen Fire Wall.

### Enclosed Burners.

These are of three types, namely, a steel-jacketed, brick-lined cylindrical shell, Fig. 84; a so-called air-cooled steel shell, Fig. 85; and a brick shell.

The first type has a cylindrical shell made from steel boiler plates and is lined with two courses of common brick and one course of firebrick from the base upward for 15 feet; with one course of common brick and one course of firebrick from 15 feet to 40 feet; with one course of firebrick from 40 to 75 feet; and with common brick from that point to the top.

The foundation is made of brick or concrete and has a solid central core several feet in diameter on which the fuel rests and an outer base on which the burner itself rests. A single or double row of wedge-shaped grates spans the gap between the central core and the foundation proper. From 3.5 to 4 square feet of grate surface per thousand board feet of mill output are required in a burner for a large sawmill and 5.5 square feet for a small one, since a large burner is more efficient than small ones.

The fuel enters the burner about 40 feet above ground, and is brought to the burner by some form of refuse-conveying chains traveling in a wooden or metal trough. This conveyor is driven from the mill end. The draft enters through doors which open into the chamber under the grates. Several clean-out doors are provided at the grate level. The top of the burner is covered with a 3 by 3 mesh, 14-gauge wire screen to prevent the emission of sparks.

Water-cooled burners do not have a brick lining, but, a steel jacket is placed around the burner, providing a water compartment between the inner and outer shells, which are from 12 to 15 inches apart. The heated water from this shell may be pumped to the boiler room, in which case the burner serves as a water heater. Burners of the above type are built in sizes ranging from 18 feet in diameter and 85 feet in height to 50 feet in diameter and 115 feet in height. These burners are now becoming obsolete because the maintenance cost is three or four times greater than the standard type of enclosed burner. The water level in the jacket varies as the heat increases or decreases, and this causes an unequal expansion of the metal, which in turn leads to leakage. The enclosed type of burner, even when brick-lined, is rather expensive to maintain because the firebrick often must be renewed annually. The outer shells of both the water-jacket and the brick-lined types must be kept well painted to prevent rapid corrosion.<sup>1</sup>

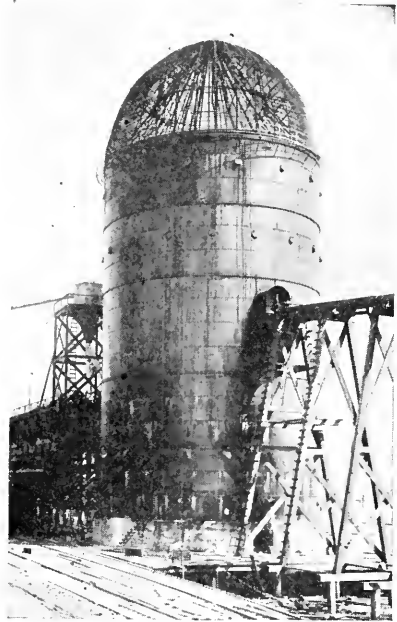

*Photograph by Seattle Boiler Works, Inc.*

Fig. 84.—An Enclosed Refuse Burner.

It is usual to express the capacity of a burner in terms of the output of a mill. The smallest size, the 18-foot burner, will serve a mill cutting 50,000 board feet in ten hours; a 30-foot burner one cutting 125,000 board feet; and a 50-foot burner will handle the refuse of a 350,000-foot mill.

An air-cooled type of burner, designed and patented by a western operator, was placed on the market about 1916. This burner is conical

<sup>1</sup> Steel burners located on tide-water require a heavier shell than those located at interior points, because of the corrosive action of the salt air.

at the base, and has a cylindrical stack without an interior brick lining.<sup>1</sup> The foundation is a concrete wall from 8 to 12 inches thick which extends from 18 to 24 inches above the grate level. The foundation also has openings by means of which air is admitted to a chamber under the grates. The frame work is made from structural steel and from iron pipe with an outside covering of medium-weight steel plates riveted together to make it practically air-tight. Steel angle uprights 3 by 3 inches in size are bolted to the outside of pilasters which are placed at frequent intervals along the foundation. These pilasters



*Photograph by Colby Steel and Engineering Co.*

FIG. 85.—A 60-foot Air-cooled Refuse Burner. This serves a Puget Sound Sawmill in which 200,000 Board Feet of Lumber are manufactured in Eight Hours.

are thirty-two in number on a 70-foot burner. The uprights converge toward the center at an angle of  $67.5^\circ$  until they reach a height of 46 feet above the grate level. Angle irons extending vertically to a height of 27 feet and forming the frame of a cylindrical stack 26 feet in diameter are attached to the upper end of each alternate slanting upright. The uprights are braced laterally by 1-inch iron pipe ribs framed into rings. These rings extend around the superstructure and are attached to the uprights by U bolts. The distance between rings is 30 inches. The outside shell is made from 16-gauge steel sheets riveted together, and is attached to the iron-pipe ribs by strap-iron clips. It extends 16 inches beyond the foundation and 6 inches

below it, leaving an air space between the foundation and the superstructure. The top screen is made from 16 gauge 6 by 6 mesh wire supported on a framework made from 2- by 2-inch steel angle bars. The grates are placed in the center of the burner floor, the arrangement and grate area being dependent on the amount and character of material to be burned.

The manufacturers claim that this type of burner can be installed for 75 to 85 per cent of the cost of brick burners; for 50 to 60 per cent of the cost of brick-lined steel burners; and for 25 to 35 per cent of the cost of water-jacket steel burners.

A burner with a 50-foot base will handle the refuse from a mill cutting 100,000 board feet in one shift, while a 70-foot burner will

<sup>1</sup> See Fig. 85.

handle the refuse from a mill cutting 200,000 board feet of lumber and 300,000 shingles. This type carries the same insurance rating as the brick-lined or water-jacketed burners.

The brick-shell burner is cylindrical in shape, and is equipped with the same devices as the brick-lined steel burner. It is not used at large plants.

### **Relative Fire Hazard of Open and Enclosed Burners.**

Open-pit burners are regarded as a greater fire hazard than enclosed burners and mills using them must pay higher insurance premium rates if the burner is to be located within a reasonable distance of the sawmill and the lumber yard.<sup>1</sup>

<sup>1</sup>The recognized fire hazards of open pit and enclosed burners as shown by additions to base insurance rates may be found in the Appendix, page 515.

## CHAPTER V

### SAWS

THERE are three classes of saws used in a sawmill, namely, circular, band, and reciprocating. The circular saw is used for breaking down logs and for edging, trimming, and cross-cutting purposes; therefore it is used both for ripping and cross-cutting. Band and reciprocating saws are used as head-saws or resaws for ripping logs, cants, and slabs.

#### SAW TEETH

Saw teeth are of two patterns, namely, the swage-set or square-dress, Fig. 86*a*, and the spring-set or briar-dress, Fig. 86*b*. Both types may be used as rip saws, but with minor exceptions only the spring-set is used for cross-cutting purposes. Rip saws in large mills are swage-set, but sometimes those in small mills are spring-set. Swage-set is preferred because one tooth, square dressed, will do twice the work of a tooth which is spring-set. The fibers, in rip sawing, are cut in lengthwise direction and are chipped off by the chisel-like action of the tooth, while the fibers are severed in a cross-wise direction in cross-cutting. Swage-set saws will stand a higher feed than spring-set saws, because a tooth cuts across its entire face and, if properly fitted, produces small chips rather than dust.

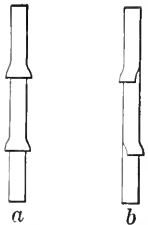

FIG. 86.—Types of Saw Teeth.  
*a.* Swage Set.  
*b.* Spring Set.

“Set” in a saw is necessary because the width of the kerf must be greater than the thickness of the saw plate or blade in order to prevent the latter from rubbing against the side of the cut and becoming heated by friction. The swage or spread of the tooth must be greater for softwoods than for hardwoods, because the latter cut out smooth and clean, while soft, fibrous woods tend to pull and to leave ragged fiber ends along the edges of the cut. When cutting hardwoods the total spread of the teeth is about 4 gauges greater than the thickness of the saw and when cutting softwoods from 5 to 6 gauges greater.<sup>1</sup>

<sup>1</sup>The gauge of a saw refers to the thickness of the blade, and is expressed by numerals each of which refers to a definite fractional part of an inch. Wire is also

## CIRCULAR SAWS

**Head-saws.**

The use of circular saws for manufacturing lumber is thought to have originated in a patent granted March 16, 1820, to Robert Eastman and J. Jaquith of Bath, Me.<sup>1</sup> However, circular saws were not used in sawmills in this country until about the middle of the last century. There is an authentic record of a circular mill in operation in Manistee, Mich., in 1856.<sup>2</sup> Circular mills were introduced into Maine about the same time, but there were only a few in use for some years after 1860.<sup>3</sup>

The diameter of a circular saw depends on the size of the timber to be sawed, the usual range being from 48 to 72 inches, although there are records which establish the use of an 88-inch saw.<sup>4</sup> The saws used in large sawmills which have a double circular mill are from 60 to 72 inches in diameter and are solid toothed. The use of larger saws is seldom practicable because of the difficulty of making them stand up to heavy feed, unless their gauge is increased to a point where an excessive kerf is cut. Circular head-saws in mills of average capacity usually are 7 gauge at the center and 8 gauge on the rim. A saw 8 gauge at the center and 9 gauge at the rim, or in special cases 8 and 10 gauge respectively, may be used when valuable timber is being sawed. Saws of a gauge thinner than 8 at the center and 10 at the rim are considered impractical in sawmills because of the difficulty of fitting thin saws to do good work and because a very skillful sawyer is necessary to secure good results. When maximum output is sought, saws of 6 or 7 gauge are used because the high speed of the saw and the heavy feed require a strong saw to stand up under the work.

measured by the same method. Three wire gauge standards are in use, the Stubbs or Birmingham being the one adopted by American saw manufacturers. The values for this gauge are given in Table XLVIII, page 512, in the Appendix. The kerf cut by an 8-gauge saw would be, in the first case 4 gauge and in the second case either 3 gauge or 2 gauge.

<sup>1</sup> See *The Saw in History*, Henry Disston & Sons, Philadelphia, Pa., 1915, page 13.

<sup>2</sup> See *Northwestern Lumberman*, Feb. 9, 1895, page 6.

<sup>3</sup> See *History of the Lumber Industry*, by J. E. Defebaugh, *American Lumberman*, Chicago, Ill., 1907.

<sup>4</sup> In an article in *The Wood Worker*, Feb., 1898, page 24, a statement is made that an Indiana operator in hardwoods was using an 88-inch, 14-gauge circular saw. So far as known this is one of the largest circular head-saws that has been in successful use. An article in *Wood and Iron*, San Francisco, Cal., April 15, 1909, page 17, states that the largest circular saw in use was 84 inches in diameter. A saw 132 inches in diameter was made by the Simonds Manufacturing Co., for exhibition at the Alaska-Yukon-Pacific Exposition.

The number of teeth on a circular head-saw depends on the diameter of the saw, the kind of timber sawed, the speed at which the saw is driven, and the rate at which the log is fed against the saw. The diameter, gauge, and number of teeth in a saw should conform to the class of work it must do. Head-saws usually are built for a rim speed of approximately 10,000 linear feet per minute and at that speed a 72-inch saw would make 530 revolutions per minute. In some cases the rim speed is as high as 12,000 linear feet. A 72-inch saw running at the first mentioned speed usually has 72 teeth and one running at the latter speed either 90 or 100 teeth.<sup>1</sup>

There are a large number of saw-tooth patterns in use even for sawing a given species of wood, but there is a similarity of pattern in use by the best filers. The difference in tooth

patterns is due to the varying amount of "hook"<sup>2</sup> carried and to the difference in "pitch." The greater the hook on a saw the sharper the angle at which the tooth meets the log, the more chisel-like is the action of the tooth, and the greater its cutting ability. A saw with light hook has a scraping rather than a cutting action. This not only causes a greater strain on the saw but also

requires more power. The greater the hook, however, the thinner the tooth point, and a limit is soon reached beyond which a saw will not stand up under a heavy feed. Teeth with excessive hook feed too rapidly. A circular saw, however, will carry more hook than a band saw, because the former has a tendency to push the work away from it, while a band saw acting at right angles to the log has a tendency to pull the work toward it.

For general sawing, the normal hook of a circular saw is tangent to a circle, the diameter of which is approximately one-half the diameter of the saw,<sup>3</sup>

Fig. 87. A saw will do good work when the hook is somewhat in excess of the amount stated.

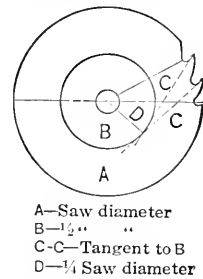

A—Saw diameter  
B— $\frac{1}{2}$  " "  
C—C—Tangent to B  
D— $\frac{1}{4}$  Saw diameter

FIG. 87.—An Illustration of "Hook" on a Circular Saw. Hook is the Angle between the Face of a Tooth and a Line drawn from the extreme Point of the Saw to the Center. The Line C often is Tangent to a Circle which has a Diameter equal to one-half that of the Saw.

The tooth patterns shown in Fig. 88 exhibit differences in tooth spacing, gullet depth and shape, hook, and pitch.

<sup>1</sup> A table showing the number of revolutions per minute and the usual number of teeth for saws from 48 to 72 inches in diameter is given in the Appendix, page 513.

<sup>2</sup> Hook is the angle between the face of a tooth and a line drawn from the extreme point of the tooth to the center of a circular saw. Pitch is the angle between the back of a tooth and a line drawn from the extreme point of the tooth to the center of the saw.

<sup>3</sup> See Simonds Guide for Millmen, Fitchburg, Mass., March, 1914.



Saws cutting softwoods will stand from one-fourth to one-third more hook than those cutting hardwoods or frozen timber because a saw for hardwoods requires a stronger tooth. Larger teeth are required for softwoods than for hardwoods or for frozen logs because the fibers of the latter cut cleaner and do not require as much gullet space.

The life of a circular head-saw depends on the character and the condition of the timber being sawed, the skill of the saw filer, and on the quality of the saw. Hardwoods wear a saw point faster than softwoods, and frozen logs or those containing foreign matter such as grit,

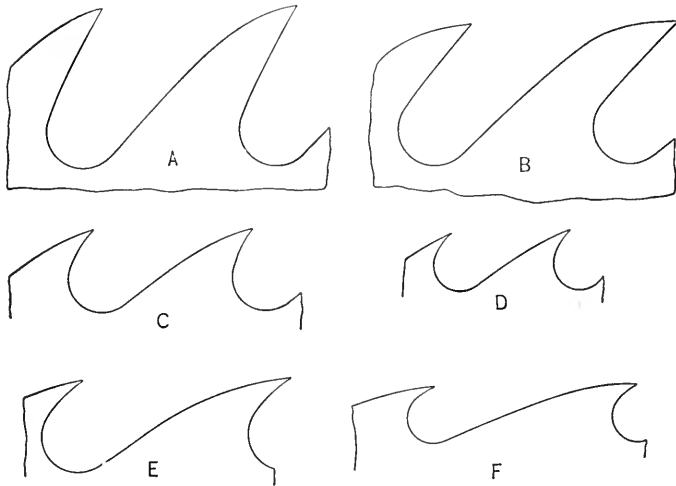

FIG. 88.—Circular Saw Tooth Patterns. A. For Southern Yellow Pine, Tooth Spacing  $2\frac{1}{8}$  Inches, Gullet Depth  $1\frac{9}{16}$ , 60-inch Saw with 90 Teeth, Feed from 12 to 14 Inches. B. For Southern Yellow Pine, Tooth Spacing  $1\frac{7}{8}$  Inches, Gullet Depth  $1\frac{9}{16}$  Inches, 52-inch, 90-tooth Saw, Feed 12 to 14 Inches. C. For Southern Yellow Pine, Tooth Spacing  $1\frac{5}{8}$  Inches, Gullet Depth  $\frac{3}{4}$  Inch. D. For Southern Yellow Pine, Tooth Spacing  $1\frac{1}{4}$  Inches, Gullet Depth  $\frac{1}{2}$  Inch. E. For White Pine, Redwood, and Douglas Fir, Tooth Spacing 2 Inches, Gullet Depth  $\frac{7}{8}$  Inch. F. For Domestic and Foreign Hardwoods, Tooth Spacing 2 Inches, Gullet Depth  $\frac{1}{2}$  Inch.

gravel, or metal wear a saw faster than when the logs are clean and unfrozen. Poor saw filing also reduces the life of a saw. With good care and under favorable operating conditions three saws have been known to keep a mill running for one year on a daily cut ranging from 60,000 to 75,000 board feet. As a rule six saws would be required for the same period. A large sawmill has on hand from four to six circular head-saws for each sawing rig, while a small mill may have from two to four.

The problems involved in saw fitting are highly technical in character and a detailed treatment is not attempted here. The main steps involved in circular saw fitting are the maintenance of, (a) a sharp, properly shaped tooth, (b) a gullet of proper size and form, (c) a circumference which is a perfect circle, (d) a proper tension in the saw so that it will run true and make a straight cut.

The first three phases of fitting are largely mechanical, once the shape of tooth is determined, since the grinding of the gullets is done by automatic machinery. The shaping of the swaged points is done by hand tools and requires only moderate skill. The tensioning of a saw, however, is done by hammering and is one of the most particular phases of saw-fitting.

In order to overcome the centrifugal force exerted by a fast running circular saw and the expansion of the saw rim due to heating, it is necessary that the saw, when at rest, shall be slightly convex on one face, and the saw is then said to have tension. The metal of the saw plate, between the center and the cutting edge, is expanded by hammering and when one side of the plate is placed flat on a stand and the opposite edge raised by the hand, the saw plate will drop away from a straight edge placed on it at right angles to an imaginary line drawn from the point of support on the bench and the point at which it is grasped by the hand. The amount of the deflection from a straight edge is governed by the diameter and gauge of the saw, the rate of feed, and the speed of the saw.<sup>1</sup> High-speed saws and thin saws require more tension than slow-speed and thick saws, because the latter are less affected by centrifugal action and are heated to a lesser degree. When a saw is properly tensioned, only the body should vibrate when the saw stands upright and is shaken, the rim being steady or nearly so. Grinding out the gullets with emery wheels and alternate heating and cooling tend to expand the rim of a circular saw so that frequent attention is needed to keep it in running condition. Tension is put into a saw by placing it on an anvil and "opening out" the body in those places in which it is "tight." This is done by the use of a special type of hammer.<sup>2</sup>

It is customary to change saws three or four times daily, since they become too dull for satisfactory service after a few hours' work. The gullets usually are "gummed" out at each second or third filing of the teeth.

The over-heating of circular saws is prevented by playing a small

<sup>1</sup>The deflection used by some filers for circular head-saws in large mills is  $\frac{1}{100}$  inch for each 100 r.p.m.

<sup>2</sup>For a brief discussion of saw-fitting problems, see Saws in the Filing Room. E. C. Atkins & Co., Indianapolis, Ind.

stream of water on the saw plate. The water reaches the face of the plate through a hollow in the arbor, which leads to small openings in the collar of the saw.

Inserted-tooth circular saws were placed on the market in the United States in the "sixties" of the last century and, to a large extent, have supplanted solid-tooth circular saws in small mills because (a) they are more easily kept in shape since the saw plate does not need to be "gummed" (hence the saw always remains circular in form and of the same diameter), and (b) an expert saw filer is not required as dull teeth may be removed and sharp ones inserted. They are not in extensive use as head-saws in large mills because, (a) they will not stand as heavy feed as solid-toothed saws of the same size since they have fewer and larger teeth, (b) they cut a heavier kerf, since the saw plate for a given diameter is usually one gauge heavier, and (c) the first cost of the saw is greater.

An inserted-tooth circular saw has a plate on the periphery of which circular milled sockets are cut, into each of which is

fitted an inserted tooth and a holder or shank, Fig. 89. The rim of the socket is ridged, a groove on the back of the holder and tooth fitting snugly over it. Teeth are removed by means of a

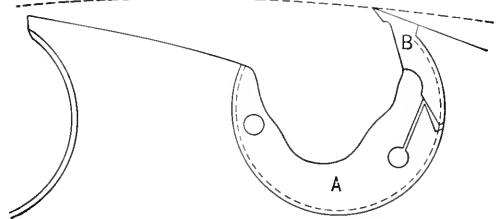

FIG. 89.—A Section of an Inserted-tooth Circular Saw Plate. A. Holder or Shank. B. Tooth.

special wrench, the side pins of which fit into two circular holes in the holder. A downward pressure on the wrench handle moves the holder and tooth counter-clockwise in the socket, the pressure being continued until the tooth is freed from the holder. Wear on the holders and on the socket ridges is overcome by the use of holders of slightly greater diameter. An inserted tooth may be touched up with a file and thus kept in a sharp condition for some time. A set of teeth will cut approximately 100,000 board feet before becoming too dull for satisfactory use.

### Edger Saws.

These are made in both the solid-tooth, and the inserted-tooth type, the latter being preferred because the saws can be kept sharp more easily. Solid-toothed saws must be removed from the edger arbor to be fitted, while the teeth of an inserted-tooth saw can be

touched up or replaced without taking the saws from the arbor. Edger saws are "fitted" as needed, but, as a rule, they are not sharpened more than three times per week. Large sawmills using solid-toothed saws carry two or three sets of them, while those using inserted-tooth saws do not carry more than one extra set of saw plates, and sometimes only one or two extra plates.

Edger saws range in diameter from 20 to 30 inches; the usual diameter, however, is 24 or 26 inches. They are from 8- to 10-gauge in thickness and are of the swaged-tooth type. They have 4 or 5 gauge swage, and cut a kerf from  $\frac{1}{4}$ - to  $\frac{9}{32}$ -inch in width. Occasionally spring-set edger saws are used which are 8 gauge and swaged to cut a kerf of about  $\frac{5}{16}$ -inch.

The usual number of teeth on a 24- or a 26-inch diameter edger saw is 24, 30 or 36. Edger saws are run at an average rim speed of 10,000 linear feet per minute, although the speed varies from 9000 to 12 000 linear feet in different mills.

### Trimmer Saws.

These are of the solid-tooth type and are spring-set. They range in diameter from 22 to 30 inches and in gauge from 7 to 8 and generally are swaged to cut a  $\frac{1}{4}$ -inch kerf. The number of revolutions per minute varies from 600 to 800. New saws adapted for cutting stock not more than 6 inches thick are 24 or 26 inches in diameter. Trimmer saws do not perform as much work as an edger saw and therefore require less filing. As a rule, they are not sharpened more than once each week, unless they are working under unfavorable conditions. A large sawmill keeps one or two spare sets of trimmer saws on hand.

### Slasher Saws.

These are of the spring-set type, and, when new, range from 40 to 48 inches in diameter and usually are 7 gauge, although they may be 6 or 8 gauge. One spare set of saws generally is sufficient. They are run at a rate of from 900 to 1000 revolutions per minute. Slasher saws are filed weekly.

### Deck Cut-off Saws.

These are spring-set and, when new, are seldom more than 72 inches in diameter. The gauge is usually 6, and the kerf cut is about  $\frac{5}{16}$ -inch. The number of revolutions per minute at which the saw is driven is

approximately 530. A large mill keeps two or three spare sets of saws on hand.

### Cut-off Saws.

These are both of the swing type and the jump-saw type and have a 7-gauge plate and range in diameter from 28 to 48 inches. They are spring-set and cut a  $\frac{1}{4}$ -inch kerf. The shape of circular cut-off saw teeth adapted to softwoods is shown in Fig. 90A and for hardwoods in Fig. 90B. One or two extra saws are carried in stock for each cut-off sawing device.

### Filing Room Equipment.

When there is but one head-saw, the filing room of a circular mill is on the sawing floor. The usual equipment includes the following machines and tools, the quantities of each depending on the number of saws of different kinds which must be kept in condition.

- Automatic saw sharpener.
- Swage.
- Swage shaper.
- Anvil or tension block.
- Hammers, round-faced and square-faced.
- Straight-edges.
- Files (assortment).
- Vise.

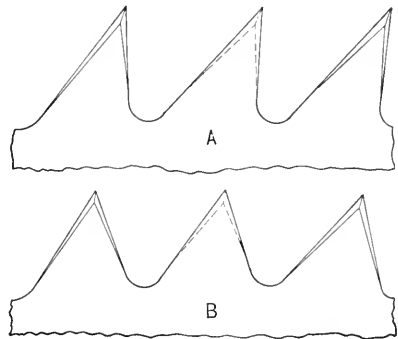

FIG. 90.—Spring-set Cut-off Saw Tooth Patterns. A. For Softwoods. B. For Hardwoods.

### BAND SAWS

The invention of the wood-cutting band saw is attributed to William Newberry, an Englishman, who in 1808 was granted a patent on a machine for sawing wood, which had an endless band or ribbon saw strung over two wheels. "Owing to the difficulty, however of obtaining new blades that would withstand the strain put upon them, the machine remained in abeyance for many years until M. Perin (a Frenchman), about 1855 introduced a much improved machine on which he used special tempered saw blades of French manufacture, and thus made the machine a practical success."<sup>1</sup>

<sup>1</sup> See *The Wood Worker*, Nov., 1903, page 39.

In the "sixties" of the last century a band sawmill was brought from England and set up in Philadelphia, but it did not prove satisfactory and was soon discarded. Previous to 1887 a band mill had not been perfected which was regarded as satisfactory by sawmill operators in this country. Many improvements were made about this time, however, and by 1889 many were being installed in sawmills. To-day they have largely supplanted circular mills in plants of large capacity.

### Head-saws.

The dimensions of band head-saws vary with the size and make of the band mill on which they are to be run. New saws range in width from 7 or 8 inches for a mill having  $5\frac{1}{2}$ - or 6-foot wheels to a maximum of 20 inches for 10-foot or larger wheels. The usual width for an 8-foot wheel is 12 or 14 inches and for a 9- or 10-foot wheel, 14 or 16 inches. The length of saw varies not only with the diameter of the wheels but also with the type of mill, since different makes of mills having the same-sized wheels often require saws of different lengths, because of the variation in distance between wheels. The top wheel of a band mill may be raised or lowered, thus varying the distance between wheels. Therefore a saw for a given mill need not always be of one length, but may have a variation of from 24 to 36 inches between the maximum and minimum lengths.<sup>1</sup>

The gauge of a band head-saw varies with its width. The usual gauge is as follows: 7-inch, 15 to 18 gauge; 8-inch, 14 to 17 gauge; 10-, 12-, and 14-inch, 13 to 15 gauge, usually 14; 16- to 20-inch, 12 to 14 gauge.

There are numerous forms of tooth patterns adapted for different kinds of woods and varying rates of rim speed and feed speed.<sup>2</sup>

A longer tooth spacing is required for high speed than for low speed because high speed with teeth close together produces fine dust which does not pocket well in the gullets of the teeth. More hook<sup>3</sup> is required for softwoods, because increased hook gives greater cutting ability, and high feed is common in softwoods. More swage is needed for softwoods and summer sawing, because the softer the wood the less clean cut are the fibers, and unless a wide kerf is cut the saw will heat. Shorter teeth are used for hardwoods and for frozen timber because they cut harder and need a stiff tooth to stand up to the work.

<sup>1</sup> See Table XLVI, page 500.

<sup>2</sup> See Fig. 91.

<sup>3</sup> Hook is the angle between the face of a tooth and a line perpendicular to the back of the saw, which touches the point of the tooth. It is measured, in inches, along the back of the saw as shown in Fig. 92.

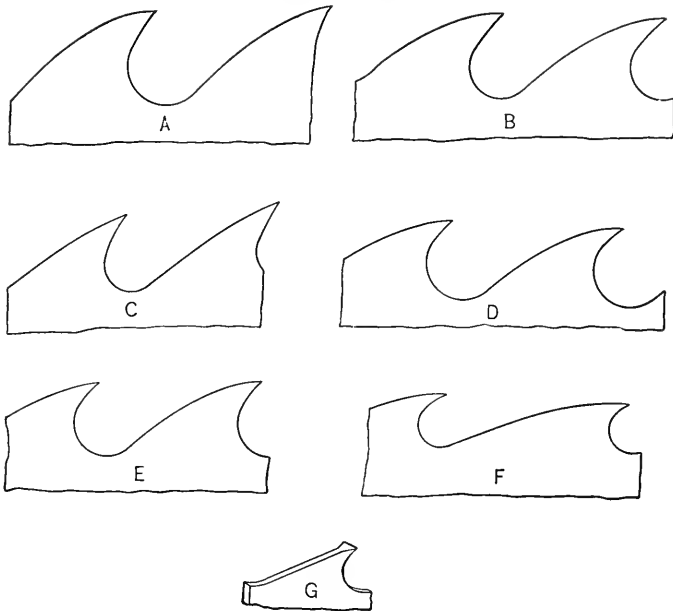

FIG. 91.—Tooth Patterns for Band Head-saws. *A.* A Tooth used on a 14-inch, 60-foot Saw cutting Douglas Fir and Western Spruce, Tooth Spacing 2 Inches, Gullet Depth 1 Inch. *B.* A Common Tooth Pattern for cutting Southern Yellow Pine, Tooth Spacing  $1\frac{3}{4}$  Inches, Gullet Depth  $\frac{7}{8}$  Inch. *C.* Tooth used on a 12-inch, 16-gauge Saw cutting White Pine, Norway Pine, Hemlock, and the Softer Hardwoods, Tooth Spacing  $1\frac{1}{2}$  Inches, Gullet Depth  $\frac{9}{16}$  Inch. *D.* A General Service Tooth Pattern used on a 14-inch, 14-gauge Saw for cutting both Softwoods and Hardwoods, Tooth Spacing  $1\frac{3}{4}$  Inches, Gullet Depth  $\frac{7}{8}$  Inch. *E.* Tooth Pattern used on a 14-inch, 14-gauge Saw for cutting Dirty, Seasoned, Chestnut, Oak, Ash, and Hickory, Tooth Spacing  $1\frac{3}{4}$  Inches, Gullet Depth  $\frac{3}{4}$  Inch. *F.* Tooth Pattern used in cutting both Domestic and Foreign Hardwoods, Tooth Spacing 2 Inches, Gullet Depth  $\frac{1}{2}$  Inch. *G.* Shape of a swaged Band Saw Tooth.

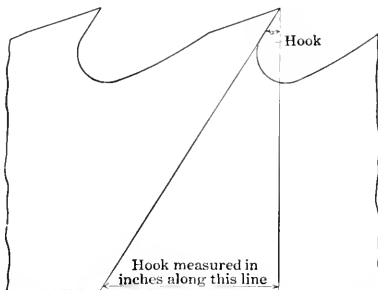

FIG. 92.—A Representation of the Method of measuring Hook on a Band Saw.

The amount of hook carried in band saws for general sawing depends upon the shape of the back of the tooth. If the back is low, less hook can be carried than where the back is high, because a low back and heavy hook produce a weak tooth. On a low-back tooth it should not exceed 4 inches on a 10-inch saw blade, while on a high back 6 or 8 inches may be carried. For a 10-inch saw it varies from 4 to  $6\frac{1}{2}$  inches, for a 12-inch saw from  $4\frac{3}{4}$  to  $7\frac{3}{4}$  inches, and for a 14-inch saw from  $5\frac{11}{16}$  to  $9\frac{1}{16}$  inches. Saws for cutting hardwood require from one-fourth to one-third less hook than those for cutting softwoods. Long teeth vibrate in the cut and therefore they should not be made longer than is necessary to furnish the space required for the dust.

A larger tooth gullet is needed for high feed than for low feed because a greater sawdust space is required. Saws for cutting softwood, therefore, require a greater gullet area than hardwoods and with teeth points farther apart. The gullet should be free from sharp corners and abrupt angles because these concentrate the bend of the saw too much at one point as it runs over the wheels.

Saws are fitted for the fastest feed and the greatest depth of cut that is to be made, since a saw so fitted will take care of any quantity of dust which may be produced.

It is advisable to have twice as many cubic inches of gullet room as the maximum number of cubic inches of wood which is to be converted into sawdust per revolution of the saw, since ample allowance is then made for the expansion of the wood fibers when they have been converted into sawdust.

It is not practicable to cut very hard woods and soft woods with the same saw. A saw which will cut the hardwood will also cut the softwood equally well, but it will not have sufficient gullet room to permit the rate of feed which should be used in sawing the latter.

A common tooth-spacing on band saws cutting southern yellow pine is  $1\frac{3}{4}$  inches, with a gullet  $\frac{7}{8}$  inch deep. A 2-inch spacing and a 1-inch gullet are often used when cutting Douglas fir, western spruce, and cork pine, while for hardwoods the tooth spacing usually is  $1\frac{1}{2}$  inches, although occasionally it is 2 inches and the gullet depth generally is  $\frac{1}{2}$  inch, although it is sometimes increased to  $\frac{3}{4}$  or  $\frac{7}{8}$  inch. The patterns of saw teeth adapted for sawing various woods are shown in Fig. 91.

Log band saws are swage-set, but thin, narrow band saws used for ripping purposes are usually spring-set, because the blade is so thin that swaged teeth will not stand up to the work required of them.

On a 14-gauge saw, the tooth width is usually 8-gauge for softwoods and 9-gauge for hardwoods and for frozen timber. In white pine a 10-gauge width may be used.



The swaged tooth should have the points carried out on either side so that no part of the saw blade except the cutting-edge comes in contact with the wood. The correct form of tooth is shown in Fig. 91.

A band saw running on the band mill wheels acts in the same manner as a belt, the cutting edge being about  $\frac{3}{4}$  inch from the wheel. In order to run without vibration the wheels must be round and in perfect balance and the wheel shafts must run free in the boxes without lost motion.

The fitting of a band saw for perfect work requires the services of a skilled mechanic, otherwise the saw may crack or it may dodge in the cut and produce a low-grade product. The teeth and gullets must be of the correct size and shape and the saw blade must be so tensioned that it will run on the wheels without vibration.

There is a great strain on the steel because band saws are bent many thousand times a day as they travel over the wheels, and a tension strain of several thousand pounds<sup>1</sup> is put on the blade in order to prevent the saw from slipping on the wheels. The faces of the band mill wheels formerly were made slightly convex, sometimes as much as  $\frac{1}{64}$  inch on a 12-inch wheel face in order to prevent the saw from running back on the wheel while in a cut. Crowned wheels are still in use, although flat-faced wheels have replaced them to a large extent.

One of the most important and difficult steps in band saw-fitting is the act of placing a uniform tension in a saw blade.<sup>2</sup> If a saw has "fast" and "loose" spots in it there is a greater tendency for the saw to crack and to run out of true because the tensile strain is increased at "fast" spots and the surplus metal at "loose" spots is repeatedly buckled.<sup>3</sup> Tensioning consists in opening up or expanding the center of the saw so that the strain will come on the edges. This must be done evenly for the entire length of the saw, otherwise it will have a lateral motion on the wheels. Tensioning is accomplished either by rolling or by hammering the blade, or by both.

When the saw is in proper tension the central portion of the blade is expanded and when raised, the middle of the saw blade will drop away from a straight-edge.<sup>4</sup> The proper amount of tension varies

<sup>1</sup> The range is from 5000 to 10,000 pounds.

<sup>2</sup> The discussion of band-saw fitting is based largely on data published in *Saws in the Filing Room*, by E. C. Atkins & Co., Indianapolis, Ind., and *Disston Handbook of Saws*, by Henry Disston & Sons, Philadelphia, Pa.

<sup>3</sup> A "fast" spot in a band saw is one which is drawn up to a straight-edge, when the saw is raised from the leveling bench. A "loose" spot is one which falls away from a straight-edge when the same test is applied.

<sup>4</sup> The maximum distance from saw blade to straight-edge is from  $\frac{1}{32}$  to  $\frac{1}{16}$  inch

with the speed and feed of the mill, the crown of the wheel, and the character of the saw blade. The greatest tension should be in the middle of the blade when no strain or pressure is exerted, but the tension should extend evenly from edge to edge when the saw is strained on the wheels.

Some saw fitters carry a "tension rim" or "tire" on the edge of the saws, although there is a difference of opinion among filers as to its value. Some carry a wide tire, others a narrow one, while still others believe that a saw runs better and makes straighter lumber when the saw blade is opened up evenly from tooth edge to back. When a tire is used the greatest tension should be carried in the center of the blade, gradually decreasing until it reaches a point from  $\frac{3}{4}$  to  $1\frac{1}{2}$  inches from the back and about 2 inches from the toothed edge. The general rule is that the wider the saw and the heavier the work it performs, the wider the tire should be.

The toothed-edge of the saw is always made tighter or of a lesser circumference than any other part of the saw in order to counteract the expansion due to the heating of the cutting-edge. This is accomplished by stretching the back of the blade either by rolling or hammering so that when a straight-edge is held against the back of the saw, the back curves uniformly away from the ends of the straight-edge. The "crown," as it is called, is usually about  $\frac{1}{64}$  inch for each 5 feet of saw back length, although sometimes it is  $\frac{1}{32}$  inch in 15 feet.

The upper wheel of the band mill is usually tilted forward slightly so that when the saw is properly stretched on the wheel there will be a uniform pressure throughout the saw.

The usual speed at which band saws are run is approximately 10,000 linear feet per minute, although in some mills this is increased

in 10 inches width. Saws are tensioned to conform to the diameters of circles, as shown in the following table:

Width of Saw, Inches	Gauge of Saw, Number	Diameter of Circle, Feet
10	14	30
10	15	35
12	13	40
12	14	40
14	13	50
14	14	50
16	12	66
16	13	66
16	14	66

to 12,000 feet. Some advocate a speed of from 8500 to 9000 feet for domestic hardwoods, and as low as 6000 feet for foreign hardwoods such as rosewood, lignum-vitæ, and Cuban mahogany. Most filers, however, seem to agree that speeds less than 8500 feet are not desirable when cutting any class of hardwood. When the maximum speed is used in mills cutting hardwood it is usual to increase the tooth spacing.

In cutting white pine and other woods of equal density, a feed speed of 24 inches on a 12-inch cut is not uncommon, while in southern yellow pine, the feed speed varies from 16 to 24 inches per revolution of the saw. The maximum feed speed when sawing hardwoods, such as hickory, is about 12 inches on a 12-inch cut.

A 12-inch saw is kept in service until it has been ground down to an 8½- or 9-inch width before it is discarded. It will last from three months to a year with average use. Saws are seldom run more than two and one-half hours without sharpening and the frequency with which they are used is an important factor in determining their life. A supply of five or six saws is kept for each band mill and, in the normal course of work, each will be used at least once every other day.

### Resaws.

Sawmill band resaws are from 7 to 11 inches in width when new and of varying lengths depending on the type of machine used. Frequently head-saws are used which have become too narrow for log-cutting purposes. In any case the shape of the tooth on a resaw is similar to that used on the head-saws. Band resaws from 7 to 12 inches wide and from 14 to 17 gauge have a tooth space ranging from 1½ to 1¾ inches and a gullet depth of ⅝ inch. The feed speed varies from 100 to 200 linear feet per minute. From three to six extra saws are carried for each machine.

### Filing-room Equipment.

The filing-room equipment used for fitting band saws necessarily varies, because of the individual opinions of saw-filers and the policy of the various operators toward providing equipment. The following machines and tools represents a complete outfit for a band saw filing room.<sup>1</sup>

- 1 Automatic band-saw sharpener.
- 1 Roll saw stretcher.

<sup>1</sup> See Disston Handbook on Saws. Henry Disston & Sons, Inc., Philadelphia, Pa. A description of these various machines and tools may be found in catalogues of saw manufacturers and of manufacturers of filing-room equipment.

- 1 Scarfing machine.
- 1 Fitting-up clamp.
- 1 Set of pulleys and stands.
- 1 Brazing clamp.
- 1 Re-toother and shears.
- 1 Forge for heating brazing irons.
- 1 Patch machine.
- 1 Anvil.
- 1 Straight-edge (5 or 6 feet long).
- 1 Straight-edge (short).
- 1 Tension gauge.
- 1 Back gauge.
- 2 Hammers, 1 cross pean, 1 ball and pean.
- 1 Hand swage.
- 1 Swage shaper.
- 1 Leveling block.

In addition to the above, the following machines and tools are required for fitting the circular saws:

- 1 Automatic circular saw sharpener.
- 1 Swage.
- 1 Swage shaper.

#### RECIPROCATING OR SASH-GANG SAWS

The blades vary in width from 6 to 10 inches, but are usually 8 inches when new. The length of the blade varies with the size and stroke of the gang mill. It ranges from 38 to 48 inches, the more common length being the maximum given. The gauge of the saw usually is 13, although 14 gauge also is in use.

There is as great a variety of tooth patterns used in a sash-gang saw as on a band saw, but, in general, the tooth spacing is  $1\frac{1}{4}$  inches, although sometimes it is  $1\frac{1}{2}$  inches. The gullet depth is from  $\frac{3}{4}$  to  $\frac{7}{8}$  inch. Patterns of gang-saw teeth in use in some southern yellow pine mills are shown in Fig. 93. The teeth are swage-set and are usually given 6 gauges of set for softwoods and 5 gauges of set for hardwoods and frozen timber. The saws are fitted in a manner similar to band saws the tension often being carried to within  $\frac{1}{2}$  inch of the edge, with a  $\frac{1}{32}$ -inch full or a  $\frac{3}{64}$ -inch drop, in the center, away from the straight-edge. The tooth-edge is made somewhat shorter than the back to compensate for expansion due to heating.

The saws are run at an average speed of 225 strokes per minute with a feed of from  $\frac{5}{8}$  to  $1\frac{1}{4}$  inches per stroke, the heavier feed some-

times being used in sawing white pine and woods of similar texture. In southern yellow pine the feed speed is from  $\frac{5}{8}$  to  $1\frac{1}{8}$  inches.

Three or four sets of saws are held in reserve for each gang mill, one set being run from five to ten hours. The average life of an 8-inch gang saw is from eight to nine months if it is in use about one-third of the time. The saws are discarded when they are worn down to a width of  $6\frac{1}{2}$  inches.

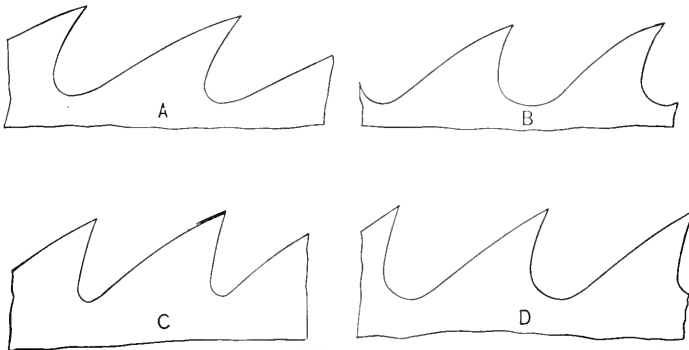

FIG. 93.—Sash-gang Saw Tooth Patterns adapted for Southern Yellow Pine. A. Tooth Spacing  $1\frac{1}{2}$  Inches, Gullet Depth  $\frac{7}{8}$  Inch. B. Tooth Spacing  $1\frac{7}{16}$  Inches, Gullet Depth  $\frac{3}{4}$  Inch. C. Tooth Spacing  $1\frac{1}{4}$  Inches, Gullet Depth  $\frac{3}{4}$  Inch. D. Tooth Spacing  $1\frac{7}{16}$  Inches, Gullet Depth  $\frac{7}{8}$  Inch.

The following equipment is needed for fitting gang saws:

- 1 Automatic gang-saw sharpener.
- 1 Swage.
- 1 Swage shaper.

The anvil, hammers and files used for band saw fitting also are adapted to gang saw fitting.

## CHAPTER VI

### LUMBER HANDLING AND TRANSFER EQUIPMENT AND METHODS

#### SAWMILL

THE lumber handling and transfer equipment in a sawmill consists of rollers, "dead" or "live" (power driven), which are used to move lumber from the front to the tail end of the mill, and chains of various patterns, usually with dogs mounted on them, which move lumber, slabs, and edgings in a transverse direction across the sawing floor.

#### Rollers.

In modern plants a line of "live" rollers is used to carry lumber, cants, timbers, and slabs from the head-saw toward the tail of the mill.<sup>1</sup> Rollers are from 8 to 13 inches in diameter and from 20 to 36 inches in length. Their usual dimensions in a large mill are 12 by 30 inches. They are mounted about 4 feet apart on bearings supported by a wooden or steel framework elevated 30 inches above the sawing floor and usually are driven either by miter gears and a shaft placed parallel to the framework or by an endless chain. A common method of mounting for gear-and-shaft drive is shown in Fig. 94. The maximum number of rollers driven by one shaft is from twelve to fifteen, although this is governed by the size of rollers and the dimensions of the material transported.

The group of rollers nearest the head-saw are run at a higher speed than those at the tail of the mill in order that the sawed product may be carried away rapidly. The speed near the head-saw may be as high as 350 revolutions per minute, while for the more distant rollers the speed may vary from 200 to 100 revolutions per minute. Twelve-by-30-inch rollers require approximately  $\frac{1}{4}$  horse-power each when run at the rate of 100 r.p.m., while rollers of the same size running at 200 r.p.m. require  $\frac{4}{10}$  horse-power each.<sup>2</sup>

<sup>1</sup> The location of the live rollers in a sawmill is shown in Fig. 24.

<sup>2</sup> See *Electricity in the Lumber Industry*, by E. F. Whitney, Proc. of the American Institute of Electrical Engineers, Vol. XXXIII, No. 12, Dec., 1914, page 1842.

A reversible friction drive is used in order that rollers may be rotated in either direction. The reversible feature is necessary because pieces may be carried further along the rollers than is desired, or a board or

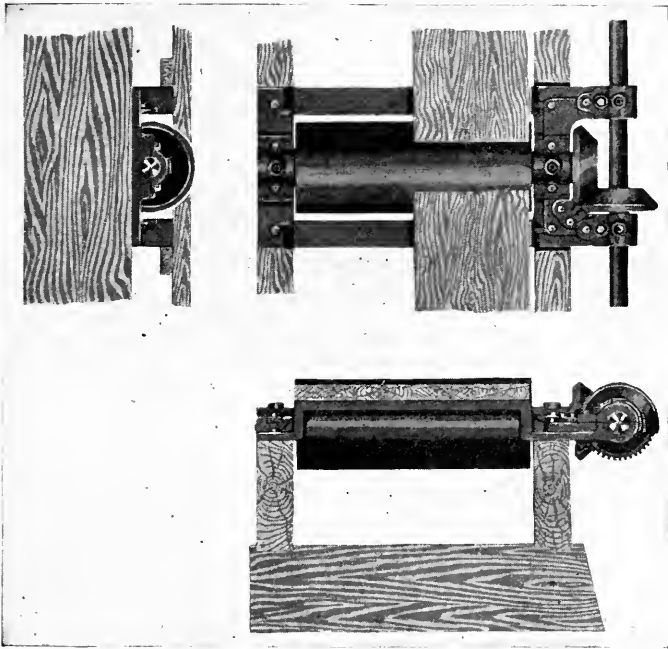

*By permission The Prescott Co.*

FIG. 94.—Gear-driven Live Rollers for Sawmill Use.

slab may be caught and by reversing the direction of travel the piece may be backed off and again started in the right direction.

The framework is made of wood or structural steel and is supported on floor posts. When conveyor chains pass underneath, the necessary span is supported by a truss which leaves a clear floor space underneath.

Rollers have a plain surface when their function is to carry material in a forward direction.

Screw rollers, shown in Fig. 95, either with right-hand or left-hand threads, may replace the plain-faced ones at points where it is desired to shunt material sideways from the line of live rollers. A short

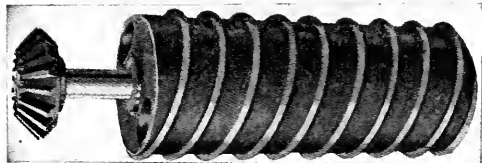

*By permission The Prescott Co.*

FIG. 95.—A Screw Roller used to shunt Slabs and Lumber sideways from a Line of Live Rollers.

distance beyond the last screw roller a "stop" is placed in the line of live rollers which is raised and lowered by a foot pedal. When the stop is raised it projects above the tops of the rollers, and arrests the progress of the material being transported and the boards or slabs are moved sideways until they drop from the edge of the rollers upon transfer chains. When timbers or lumber are to be transported beyond the stop, the latter is dropped below the level of the rollers.

**Lumber Transfers and Trips.**

Transfer chains are placed in the line of live rollers to move lumber, cants, timbers, or slabs in a cross-wise direction. They also may replace

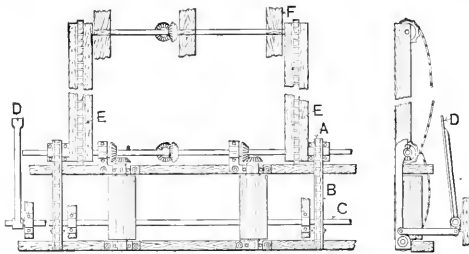

FIG. 96.—A Transfer used to move Lumber in a Direction at Right Angles to the Main Line of Live Rollers. A. Transfer Chain between the Live Rollers. B. A Skid supporting the Transfer Chain. C. Rock-shaft which elevates the Skids and Chains. D. Foot Pedal which turns the Rock-shaft and elevates the Skids and Chains.

screw rollers as a means of changing the direction of travel of slabs, for transferring lumber from the live rollers to the storage skids at the front end of the edger; and for transferring lumber to chains which convey it to the trimmer.

A transfer chain equipment has two or more endless detachable-link chains, Fig. 96, A, each supported on a short skid B, which is connected to the rock-shaft C. The ends of the skids B

nearest the rock-shaft can be elevated above the level of the live rollers by means of a foot-pedal<sup>1</sup> D attached to the rock-shaft C. Power for driving the endless chains may or may not be supplied by the shaft driving the live rollers. When a board is directly over the endless chains, it is raised above the live rollers by elevating the end of the transfer which is nearest the rock-shaft. The board or slab is then carried rapidly in a transverse direction and drops upon transfer chains E which span the gap between the live rollers and the storage skids F.

Cant trips, similar to Fig. 97, may be used to transfer cants and lumber from the live rollers to storage skids in front of a gang saw or resaw. The trip consists of two or more lever arms A, placed in the line of live rollers, and connected to the rock-shaft B. The trip arms are raised and lowered by a system of lever arms as shown. The lever arm C which actuates the rock-shaft is attached to the piston

<sup>1</sup> The foot-pedal is sometimes replaced by a steam cylinder with lever control.



of the stationary steam cylinder *D*, the latter being cushioned above and below to avoid heavy shocks due to quick action. The valves of the cylinder are controlled by a lever which is operated by the tripper. This form of trip is suitable for handling heavy stock and will shove the cants toward the gang saw, and when necessary it may be used to pile cants four or five tiers high on the storage skids upon which skid rollers sometimes are mounted (Fig. 97). The latter are about 6 inches in diameter, have a  $\frac{1}{2}$ -inch face, and are sunk into the skids so that they project about 2 inches above them. Each skid roller is mounted on a bearing and revolves when a cant passes over it.

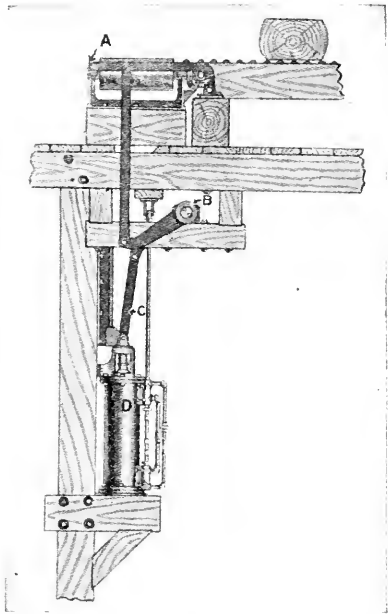
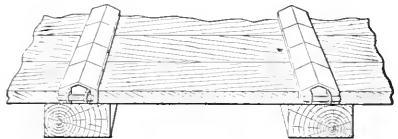
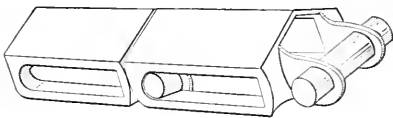

FIG. 97.—A Trip for Throwing Cants sidewise from a Line of Live Rollers to Roller Skids.

### Transfer Chains.

Various types of chains are used to move lumber in a direction at right angles to the live rollers. A type of chain, called the house-top, roof-top, or hog-back, Fig. 98, is most commonly used when boards must be shunted upon the transfer chain at right angles to its direc-



*By permission The Prescott Co.*

FIG. 98.—A Roof Top or Hog-back Chain used to move Lumber at Right Angles to the Main Line of Live Rollers. It is especially serviceable when Lumber is shunted across the Chain, since the Boards do not strike the Edges of the Chains and throw them out of their Channel.

tion of travel. The ends of the boards will not catch on the edge of this kind of a chain and throw it out of the channel in which it travels. Several endless chains placed in parallel lines are used, the width of the table depending on the board lengths handled. The chains are driven by sprocket wheels attached to a single driving shaft placed

at the end of the table next to the trimmer. Power is transmitted from driver to driven by roller chains.

On assorting tables and at other places where lumber is dropped directly upon the conveying system, as from the rear of a trimmer, conveying chains may be of the round-link type, or link-belt type, without dog attachments. Steel cables  $\frac{3}{4}$  inch in diameter are sometimes used in place of chain.<sup>1</sup>

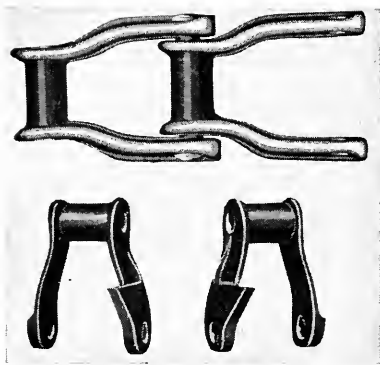
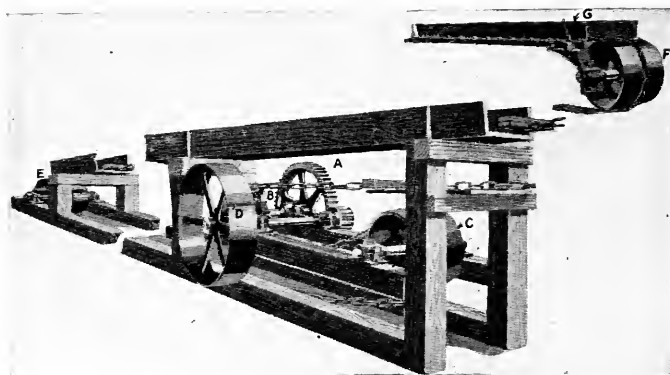

FIG. 99.—A "Heald No. 74" Transfer Chain used for moving Slabs, Edgings, and Lumber when Spur Links are necessary. The Illustration shows Plain Links and also those with Right-hand and Left-hand Spurs.

The transfer chains which carry the slabs and edgings to the slasher may be of the detachable-link type or riveted-link type, and are equipped with special dog links which replace every fourth standard link in the chain. Chains which carry the slabs and edgings against the slasher saws have detachable or riveted links, each alternate one bearing a single right-hand spur. The remainder have left-hand spurs. A common form of chain

for this purpose is the "Heald No. 74" riveted drive chain, which has right-hand and left-hand spurs as shown in Fig. 99.



*By permission Wheland Machine Co.*

FIG. 100.—The Driving Mechanism of a Refuse Conveyor Chain. A. The Gears which drive the Sprocket Wheel B. C. An Idler over which the Conveyor Chain passes. D. Drive Wheel. E. An Idler at the Mill End of the Conveyor Chain. F. An Idler at the Delivery End of the Conveyor Chain. G. A Metal Trough which forms the Terminus of the Conveyor.

<sup>1</sup> See page 137.

Conveying systems for transporting sawdust, slabs, and refuse of all kinds to the lath mill and to the refuse burner or to the fuel house travel in box-shaped chutes which are from 18 to 30 inches wide at the base. They have flaring sides about 19 inches high and a top width of from 30 to 40 inches. The conveyor chain which transports refuse to the burner often is of the same type as the jacker chain. It is equipped with hardwood or metal cleats, at 4- or 6-foot intervals, which extend across the base of the chute box and drag along the refuse. It is driven at the mill-end either by a spur or by a bevel gear and a driving sprocket which is actuated either by a belt or by a roller chain, Fig. 100. It is not practicable to drive this chain from the delivery end of a belt- and shaft-driven mill because of the

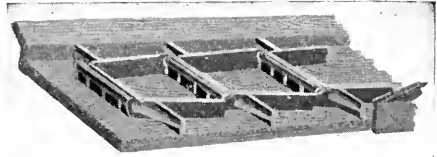

FIG. 101.—A Flat-link Chain used for conveying Sawdust and other Refuse.

distance from the source of power. In rare instances, the conveyor chain is driven at the delivery end by an electric motor.

A conveying chain for sawdust differs from one used for slabs because the cleats on a slab conveyor do not fit the box closely enough to carry fine material. One of the several types of sawdust chains with links 7, 10, or 12 inches wide is shown in Fig. 101. Two parallel chains of this type operating in the same box may be used to carry slabs and other refuse away from behind the slasher.

### Belt Conveyors.<sup>1</sup>

Belts as a substitute for chains or live rollers, are coming into use because of their speed, lower power consumption, lightness of parts, low maintenance cost, easy and rapid repair, and relatively long life. They are more common in the West than in other regions, although they are occasionally used in the southern yellow pine mills to move lath bundles.

These belts are made especially for conveying purposes and are either 4-, 6-, or 8-ply canvas with longitudinal stitching. The faces of belts are rubber-coated, when they are subjected to excessive wear. On account of the limited strength of the fabric, they require a uniformly distributed load. They have proved feasible for handling boards, shingles, laths, and wood refuse, but are not applicable for sawmill use at any point where timbers must be handled.

<sup>1</sup> See Belt Conveying in Sawmill Plant, by F. F. Murray, Lumber, St. Louis, Mo., Aug. 26, 1921, page 15.

They may be used to carry lumber from resaws to the trimming table; from edgers to the grading and assorting table; and from the assorting table to the kiln-truck loading points. They also may be used to carry shingles and laths to the drying or storage points, to carry hogged fuel to the fuel house, and firewood to concentration points. There are numerous examples of their use in planing mills for transferring lumber from the machines to the assorting table and for assembling stock for bundling.

#### GREEN LUMBER ASSORTING

Lumber is graded and assorted by quality and sizes as it leaves the tail of the mill. The amount of assorting depends largely upon the manner in which the sawed product is seasoned. For example, in many southern pine mills the finishing grades of lumber are seasoned in dry kilns, while the "common" grades are usually air-dried in the yards. At some mills, however, a portion of the No. 1 common boards also may be kiln-dried and sometimes a part of the No. 2 common, if the mill is short on this stock. A few mills kiln-dry their entire output.

Softwoods which are air-dried are assorted both by grades and by sizes. Kiln-dried stock usually is assorted by sizes only, when green; distinctions in the quality of "finishing" lumber are made only after the product has been taken from the dry kilns.

#### Assorting Table.

The grading and assorting usually are done on an assorting table which runs from the rear of the trimmer in a direction at right angles to that of the sawmill building.<sup>1</sup> Its length varies with the amount of lumber handled daily, and with the methods of transporting the lumber to the kilns and yards. The width of the table must be sufficient to handle the general run of board lengths cut at the mill, although pieces of a length greater than the average may be handled by placing them diagonally across the table.

Mills cutting standard lengths in southern yellow pine have a table from 12 to 20 feet in width, usually between 12 and 16 feet, with a height of 30 or 32 inches. The length is governed largely by the method used to cart away the lumber. A length of from 130 to 160 feet is sufficient for a two-band mill at which the lumber is hauled to the yards on lumber buggies and kiln stock is assorted by means of an edge sorter.<sup>2</sup>

<sup>1</sup> See *T*, Fig. 24, for the position of the assorting table. The table may be placed on either the right-hand or the left-hand side of the mill, in the relative position shown.

<sup>2</sup> See page 137.

A platform 20 feet or more in width is built on one or both sides of the assorting table and serves both as storage point for lumber buggies, trucks, or other equipment which may be used to carry the lumber to other parts of the plant, and for a runway over which they may be hauled. When a monorail system is used to take lumber from the assorting table to the storage points, the platform is made only wide enough to permit the storage of the unit packages as they are prepared.

A runway about 6 feet wide and 12 or 15 inches higher than the storage platform is built on both sides of the assorting table and the sorters stand on this as they pull the lumber from the table and stack it upon the trucks or stands.<sup>1</sup>

Some assorting tables are built with two decks. Lumber from the trimmer is delivered on the upper deck, which has slots through which boards of given lengths can drop upon the lower table, where they are graded and made into packages.

The assorting table is equipped with two or more parallel lines of cables or chains spaced 6 feet or more apart, which carry the lumber away from the rear of the trimmer at a rate of from 75 to 90 linear feet per minute. These chains may be of the round-link, detachable-link, or riveted-link drive chain type, without dog attachments, or steel cables without attachments may be used. Short auxiliary chains placed directly behind the trimmer and midway between the main chains, facilitate the handling of short lengths, which are pulled from the assorting table as soon as they leave the trimmer.

It is a common practice at many mills, which kiln-dry a portion of the cut, to assort the product by sizes using a so-called edge sorter. The lumber is carried to the end of the assorting table, where it is placed on storage skids which are parallel with the edge sorter.

### Edge Sorter.

The edge sorter, Fig. 102, has a line of high-speed live rollers 30 inches or more in length, spaced 4 feet apart, which run from the end of the assorting table to the far end of the kiln-truck loading points, paralleling the latter and at right angles to the former. A series of slots with sides made from 2-inch plank, or from thin steel plates, set on edge and spaced from 2 to 3 inches apart are placed above the rollers. The planks or plates are fastened to timbers underneath the rollers. The slots serve as runways for the assorted material, the number of slots depending on the extent to which the product is assorted by lengths and thicknesses. The slots lead to storage pockets in front of the kiln-

<sup>1</sup> The equipment used for moving lumber is described on pages 140 to 156.

truck loading points, each storage pocket receiving material of a given length and thickness.



FIG. 102.—The Terminus of an Edge Sorter showing Storage Pockets on the Left.

The edge-sorter is "loaded" by a workman who places the lumber on edge in the proper slot as it comes to him from the assorting table. When the lumber reaches the end of a given slot it is shunted out of the sorter to the storage skids below from which point it is loaded directly upon the kiln-trucks.

#### Hanson Assorter.

The Hanson lumber assorter,<sup>1</sup> in use at a Pacific Coast cargo mill, is shown in Fig. 103. It has several sets of parallel rollers which

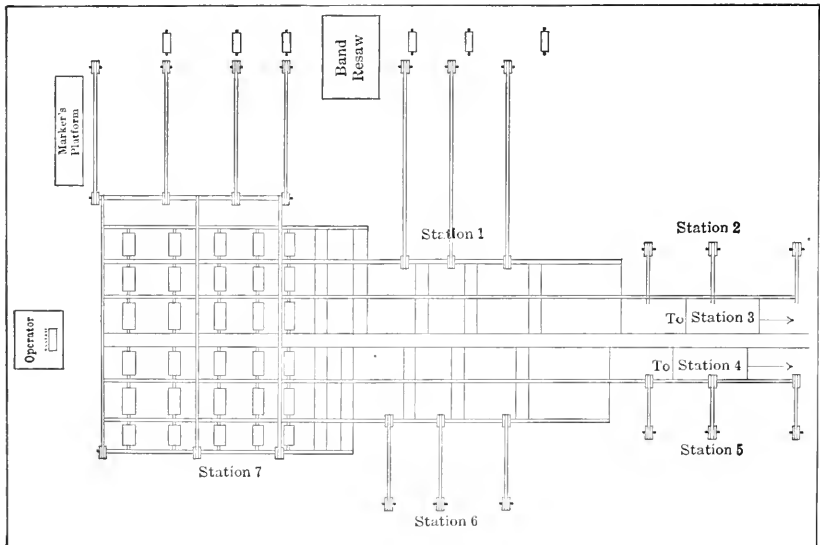

FIG. 103.—The General Arrangement of a Hanson Green Lumber Assorter.

<sup>1</sup> See The Timberman, Oct., 1909, page 40.

run at right angles to the chains *A*, which bring lumber from the mill to the assorter. Each set of rollers is mounted on a single frame with a pneumatic raising device. When at rest, the tops of the rollers are below the line of the transfer chains. Each set of rollers ends at a storage point or station where the lumber is deposited, ready to be loaded on trucks and hauled directly to the ship side.

There also is a storage pocket at the end of the transfer chains where all lumber is deposited which is not sent along one of the lines of rollers. In the diagram shown, the boards which are dropped at station 1 are carried to the front of the resaw, and after being re-manufactured again pass over the assorter.

The operator, who controls the pneumatic raising device, elevates the proper set of rollers and diverts the lumber to the proper station.

#### TIMBER DOCKS

Mills which manufacture timbers in large quantity have a timber-loading dock, Fig. 104, which furnishes the needed storage and

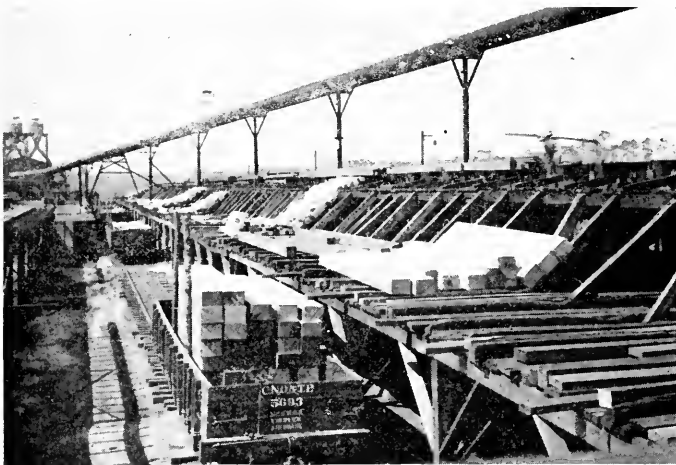

FIG. 104.—A Timber Dock at a Southern Sawmill Plant.

loading space. The dock usually is wide enough to hold from one-half to one carload of timbers. A line of "dead" or "live" rollers, which parallel the top of the timber dock, is a continuation of the line of live rollers behind the head-saw. Timbers are thrown from the rollers upon the greased skids of the dock by workmen who use cant-hooks or peavies. In loading cars, the timbers are shoved along the skids, by means of peavies, until they reach the edge of the dock

when they are dropped upon the car. A railroad track on which cars may be spotted for loading is located on one side of the dock.

#### TRANSPORTATION ABOUT THE PLANT

The movement of lumber from one part of the plant to another involves the daily handling of many tons weight. The amount of lumber handling varies with the plant management and the methods of seasoning and shipping. Green lumber is carried direct from the assorting table or the sawmill to the dry kilns or to the storage yards; kiln-dried lumber from the dry kilns to rough-dry sheds, to the planing mill, or to the loading dock; and air-dried lumber from the yards to the planing mill, or to the loading dock. Timbers are shipped in a green condition and go directly from the live rollers behind the saw to a "butting" machine, then to a surfacing machine if they are dressed, and finally to a timber dock from which they are loaded directly on freight cars.

There are various methods of moving lumber and timbers from one part of the plant to another, among which are;

- (a) Wheeled vehicles, pushed by hand, drawn by an animal or by animals, or by a tractor.
- (b) Surface carriers.
- (c) Overhead monorail systems.
- (d) Cranes, either stationary or traveling.
- (e) Conveying devices, such as live rollers, chains, or cables.
- (f) Overhead cableway systems.
- (g) Small cars traveling on rails and drawn either by animals, or by a light locomotive.

#### Wheeled Vehicles.

*Lumber Buggies.*—One of the common methods of moving lumber is by the use of two-wheeled lumber buggies which have wheels from 24 to 30 inches in diameter and with 3- or 4-inch tires. The type shown in Fig. 105 will carry from 1000 to 1500 board feet of lumber.

The minimum requirements are at least one and one-half buggies for each thousand board feet of lumber manufactured in ten hours. They may be pushed by hand but usually are drawn either by animals or by tractors. Buggies are lined up along the side of the assorting table and at right angles to it and lumber is pulled from the assorting chains and piled on the buggies so that they are nearly balanced, there being a slight excess of weight on the ends next the assorting table.



A low-wheeled draft truck fitted with shafts, a whiffle tree, a swivel bunk, and either with or without a reach is used when the buggy is drawn by animals. This truck, to which the draft power is attached, is backed under the forward part of the load, the projecting ends of the lumber lowered upon the bunk and fastened to it by means of a chain thrown around the load. On reaching the spot at which the lumber is to be deposited, the chain is released and the teamster drives off with the draft truck only.

The upkeep of buggies amounts to about 10 per cent annually. Repairs, other than the replacement of wheels, can be made at the mill plant. The usual allowance of animals on an average haul is approximately six for each one hundred buggies. With a buggy of this character an animal will move, daily,

about 15,000 board feet for a distance of one mile. The advantage claimed for the two-wheeled buggy is that it may be taken to any part

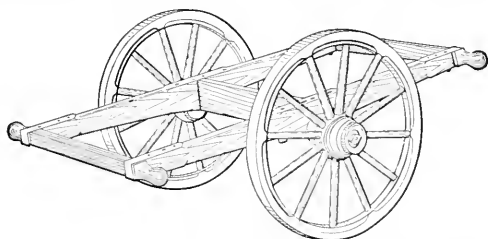

FIG. 105.—A Common Type of Two-wheeled Buggy used for moving Lumber at Sawmill Plants.

of the plant without reference to track or other special surfaces on which to travel. It is the best type for small mills as power-drawn devices have a capacity greater than is required for a limited output. The disadvantage of this or any other type of animal-drawn wheeled-equipment is that docks rapidly deteriorate under the constant travel of shod animals and, therefore, the expense of maintenance is heavy. Animal-drawn lumber buggies also are inefficient from the standpoint of draft when the dock floor is in poor condition, or when there are steep ascending grades.

The framework shown in Fig. 105 often is modified to meet special conditions. It may be made longer and of larger material in order to support heavy loads, such as timbers.

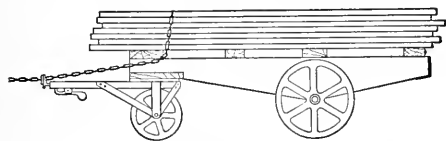

FIG. 106.—A Three-wheeled Buggy used for transporting Lumber at Sawmill Plants. The Draft Power is attached to the Chain.

A leg or legs may be attached to the frame to hold it in a horizontal position. In some cases the leg is replaced by a small third wheel, which answers the same purpose and which also facilitates handling the load.

The advantages claimed for the three-wheeled lumber buggy shown in Fig. 106 are as follows: there is a marked saving in

power required to move a given load, since no part of the lumber drags; it stands level, without blocking, while being loaded; and it is adapted not only to long and short lumber, but also to laths, fuel-wood and other short stock.

*Four-wheeled Trucks.*—The chief advantage of the four-wheeled truck is its greater carrying capacity. It is not adapted to hand power, and, therefore, is not used where hand trucking is necessary or desirable. It is more commonly used to haul lumber from the yards and rough dry sheds to the planing mill than for any other purpose.

*Four-wheeled Wagons.*—Wagons with a carrying capacity of from 1200 to 1500 board feet and equipped with a roller above the rear axle<sup>1</sup> are sometimes used for moving lumber from the assorting table to the storage yard. Lumber is stacked in piles on roller skids as it is pulled



FIG. 107.—A Wagon with a Rear Roller used in hauling Lumber from the Assorting Table to the Yards. The view shows the Wagon short coupled for ease in hauling it when empty.

from the assorting table. The wagon is backed under the load until the outer end of the pile rests on the front wagon bunk. A chain is then thrown over the forward end of the load and made fast and as the wagon leaves the assorting table the lumber is pulled from the storage skids and settles down on the roller bunk at the rear. The load of lumber will drop, as a unit, from the rear end of the wagon when the teamster releases the binding chains and drives forward.

The high cost of labor, of animals, and of feed has made animal traction expensive, especially on long hauls, and various forms of tractors have been devised as a substitute for animal power, which have proved so successful that their introduction has been very rapid during recent years.

*Tractors.*—Tractors are driven either by a gasoline engine, often

<sup>1</sup> See Fig. 107.

of the Ford type, or by electric storage batteries. They have low, solid, rubber-tired wheels, seldom more than 24 inches in diameter, and a short wheel base.

The advantages of a tractor as compared to an animal for hauling lumber around the sawmill plant are that it can approach a load and pull it to any point in a yard or shed that an animal can; it can be attached and detached from a truck load of lumber in the same time required for an animal-drawn vehicle; it has greatly increased speed over animals;<sup>1</sup> it does not require any resting period; it can do the work of three animals; it does not cost more to maintain a well-built machine than the feed of one animal and will outlast its value in animals several



*Photograph by Sumner K. Prescott Co.*

FIG. 108.—A Prescott Lumber Tractor.

times; it reduces the number of employees needed; and it effects a marked saving in tram bottoms, which wear out under animal traffic in from two to three years.

The Prescott lumber tractor, Fig. 108, equipped with a four-cylinder, 22 horse-power Ford engine, weighs approximately 2800 pounds, and consumes from 12 to 15 gallons of gasoline in twenty-four hours. The framework is made of channel iron, and is mounted on 22-inch, solid wheels. It will draw both two-wheeled and four-wheeled lumber buggies and has a rated pulling capacity of from 1000 to 3000 board feet, under yard conditions. The rear end of the tractor is backed under the forward end of a load of lumber on a buggy, and a chain is thrown over the top of the load and tightened by means of the winch shown in the figure. Two men are required to operate

<sup>1</sup> The maximum practical speed of a lumber tractor is 6 miles per hour, while that of an animal is about  $2\frac{1}{2}$  miles per hour for average hauls and less for long hauls. Tractors will average about ten round trips per hour for distances of 600 feet.

a tractor to maximum capacity, one to drive and the other to attach and detach the truck.

### Surface Carriers.

Moving lumber in unit packages by some form of surface carrier has been developed largely in the Northwest, where it is now quite extensively used. They are of two types, namely, (a) one that moves units of lumber stacked on bolsters only, and (b) one that picks up a loaded lumber buggy and moves it to the desired place.



*Photograph by Ross Carrier Co.*

FIG. 109.—A Ross Lumber Carrier driven by Electric Storage Batteries.

The advantages claimed for a surface carrier as compared to a tractor are that it is a one-man machine; all of the load is carried on the machine itself; and it has greater flexibility, since it can move forward or backward with equal ease and therefore can "spot" a load in places where a tractor or a horse would be unable to place it because of the space required to turn and get out.

A surface carrier which handles lumber in units without lumber buggies is shown in Fig. 109. This machine is electrically operated throughout and has a four-wheel steering apparatus which enables it to turn a right angle in traveling a distance of 8 feet. The lumber is placed on two 3- by 8-inch by 42-inch bolsters spaced 7 feet and 2 inches, center to center. These bolsters are raised from the floor by

4- by 6-inch blocks placed under them, the ends of the bolster projecting 3 inches beyond the blocks.<sup>1</sup> Each machine is equipped with four carrying hooks, the ends of which are caught under the projecting ends of the bolster and serve as a means for raising the unit from or lowering it to the floor.

The lumber is piled on the bolsters at the assorting table in units 4 feet high and 3 feet wide. The carrier drives over the load and the carrying hooks are lowered and caught under the ends of the bolster. The load is then raised by a power hoist, and carried to its destination. It can carry pieces from 8 to 100 feet in length and has an average capacity of 2200 board feet of 16-foot rough stock. A machine

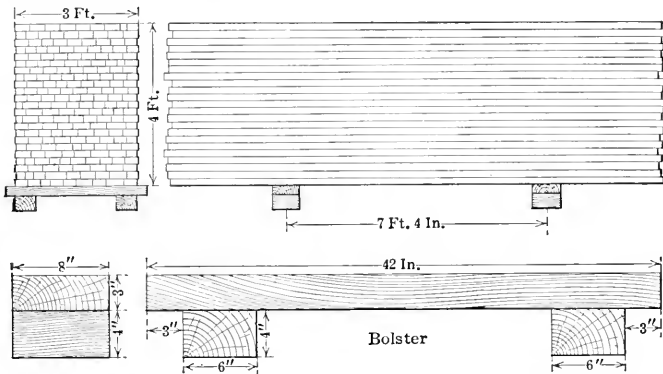

FIG. 110.—The Method of piling Lumber on Bolsters for handling with a Surface Lumber Carrier of the Ross Type.

of this type can handle the assorting table output of a mill cutting from 80,000 to 100,000 board feet per day.

A similar machine driven by a gasoline engine mounted on top of the frame is now on the market. It will handle units 42 inches wide, and 52 inches high and will carry a load of 8 tons. It is equipped with a friction drive and has a maximum carrying speed of 15 miles per hour.

A surface carrier that handles loaded lumber buggies was developed on the Pacific Coast several years ago, but it has not been adopted as extensively as the unit package type.

### Monorail System.

A monorail system is used to transfer lumber from the assorting table to the storage yards; from the assorting table at the dry kilns to the rough dry sheds; from the yards and sheds to the planer and car; and also from various parts of the plant to vessel docks.

<sup>1</sup> See Fig. 110.

The advantages claimed for an overhead monorail system are the handling of lumber in unit packages, which reduces the amount of labor required, and large capacity per machine. The method has the disadvantage that lumber must be dropped directly under the elevated track and if sufficient parallel track is not provided the length of haul usually must be long, unless some auxiliary hauling devices, such as lumber buggies or wagons, are used to truck the lumber away from the monorail line. This is sometimes done to avoid a long animal

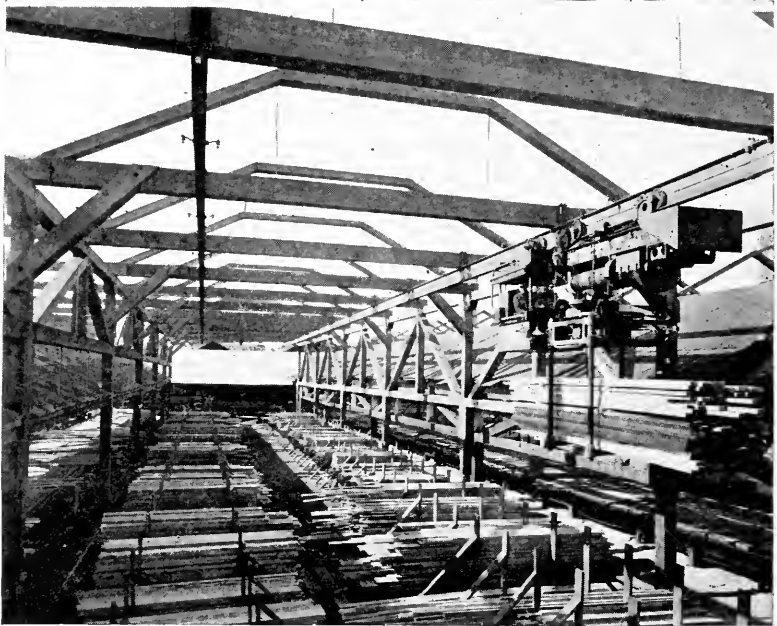

*Photograph by Pauling & Harntschfeger.*

FIG. 111.—An Overhead Monorail System for moving Lumber from the Assorting Table to other Parts of the Plant. Note the Units which have been made up as the Lumber was pulled from the Assorting Table.

haul. The first cost of construction is relatively high, but this is offset, to a considerable extent, by efficiency in moving lumber.

The chief features are an aerial I-beam suspended from an A support of piling or squared timbers which provides a track on which travels a suspended hoist with an operator's cab attached to the rear.<sup>1</sup> Suitable switches permit the hoist to move from the main line to spurs and traveling transfer devices enable the operator to shift the hoist and load from one parallel track to another within a confined space,

<sup>1</sup> See Fig. 111.

such as in a storage shed. The hoists are built in capacities of from 3 to 5 tons and have a channel-steel frame carrying the motor and two revolving drums on which are wound the cables that raise or lower the turn-table and grappling hooks by which the units are suspended. The turn-table permits of a quarter turn so that loads at right angles to the direction of travel may be picked up readily and then turned in a direction parallel to the line of travel.

Two electric motors are mounted on each hoist, one being used for propelling the hoist, and the other for raising and lowering the turn-table and grapple hooks. A 250-volt direct current is supplied to the motor by brush contact with feed wires placed parallel to the I-beam.

The height of the I-beam supports varies with the ground surface, since the system requires a fairly even grade for efficient operation. The supporting bents, made from timbers 12 by 14 or 14 by 14 inches in cross-section, usually are from 20 to 24 feet apart on tangents and from 8 to 10 feet apart on curves which should not have a radius less than 30 feet.

The lumber units contain about 1600 board feet and are 4 feet wide and usually twenty-five 1-inch courses in height. Any moderate length of board can be handled.

There is a runway on one or both sides of the assorting table, with proper stands on which to make up the units. The lumber, as it is pulled from the assorting table, is piled on two 4- by 4-inch cross pieces, properly spaced for the grappling hooks. If the lumber is green and is to be seasoned in the yard, stickers must separate the different layers of boards, while kiln-dried stock is piled solid.

When a given package is complete, the hoist is run in on the line and stopped over the unit. The turn-table and grappling hooks, turned at an angle of 90 degrees to the direction of travel, are then lowered until the hooks engage the cross pieces. Then the load is raised by means of the cables, turned parallel to the direction of travel, and transported to destination at a maximum speed of about 500 feet per minute. The machine may be used with one operator but a laborer often is employed to see that the grappling hooks are properly attached.

A hoist may be transferred from one line to another one parallel to it by running the hoist upon a self-propelled transfer crane.<sup>1</sup> When the transfer is in alignment with the desired runway, the transfer crane is locked, and the hoist runs off from it on to the new line. The transfer crane may be operated by the hoist engineer, but often has a separate operator.

The amount of track at a plant depends upon the use to which the monorail system is put. It may be from 1200 to 1400 feet in

<sup>1</sup> Fig. 112.

length when only a portion of the lumber output is handled, while it may be 25,000 feet or more when the entire output of a large mill is handled. One operator can move, on an average, about 100,000 board feet in ten hours.

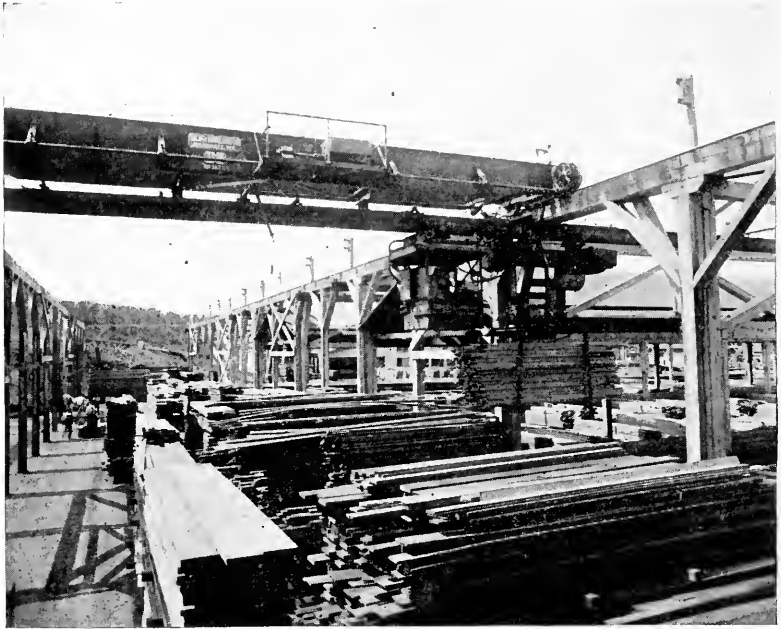

*Photograph by Pauling & Harnischfeger.*

FIG. 112.—A Monorail Transfer used to transfer a Carrier from One Track to Another.

### Cranes.

There are various kinds of cranes used in handling lumber, the cantilever, Gantry and locomotive types being the more common. The first two types are used for high piling at plants which are cramped for space; for handling heavy timbers; and often in connection with some other transport system. Both types are used to load and unload cars and vessels. The last type, the locomotive crane, is used to transport lumber from the assorting table to the storage yard, to place lumber on piles for stacking and also to load and unload cars and vessels. Therefore, it is a more versatile machine and is preferred by many. All of these forms handle lumber and timbers in units.

*Cantilever Crane.*—One type of cantilever crane, known as the Samson crane, is shown in Fig. 113. It has a counter-weighted boom, often 70 feet or more in length, which, with the various drums and power



devices housed in a cab, is mounted on a revolving base which permits the boom to swing in a complete circle. A trolley is placed on the under side of the boom and may be run back and forth between the cab and the end of the boom by means of cables. The loading line which runs from the cab through the trolley has a hook, tongs, or some other grappling device on the free end for handling lumber packages or timbers. The crane travels on a track having a gauge of 16 feet or more and the legs are long enough so that there is sufficient clearance above the rail to permit a freight car to pass underneath. This machine is built in 5- and 10-ton capacities.



*Photograph by Colby Steel and Engineering Co.*

FIG. 113.—A Samson Cantilever Crane with a 76-foot Boom, operating on the Dock of a Puget Sound Sawmill. It is used both to store Lumber and to deliver it to the Ships' Tackle, and has a 10-ton Lifting Capacity at a 35-foot Radius, 5-ton Capacity at a 70-foot Radius, and a 4-ton Capacity at a 76-foot Radius.

The power for operating the Samson crane is electricity, about 50 horse-power being required for a 10-ton crane. It is claimed by manufacturers that 492,000 board feet of lumber have been handled in eight hours with a crew of two men. The storage capacity of a yard when a machine of this kind is used is said to be 850,000 board feet per 100 linear feet of track. These cranes are especially serviceable at cargo mills, since the product can be delivered on board the vessel in large units. It does not require as much track space as the Gantry type mentioned later.

A stationary cantilever-arm crane is sometimes employed in loading

and unloading barges and vessels along rivers where there is a marked rise and fall in the water level.

Another type of cantilever crane used for conveying lumber from the assorting table to the dock has a crane arm supported on a broad storage base traveling on a wide-gauge track. A trolley running back and forth on the crane arm enables the machine to pick up or deposit packages of lumber on either side of the crane or to place them on the storage base. The machine takes packages from the assorting table, stores them on the crane platform and then under its own power transports them to the temporary storage areas along the track, or else takes



Photograph by Pawling & Harnischfeger.

FIG. 114.—A Gantry Crane used for loading Lumber on Vessels. The Crane is self-propelling and can travel under its own power in a Direction at Right Angles to the Crane Arm. The Trolley shown at the Extreme Right of the Arm can travel back and forth, thus spanning both the Vessel Hold and the Storage Area on the Dock.

the packages directly to the loading dock, where they are placed on barges or on boats. The capacity of the storage base of the crane is about 30,000 board feet. This machine is operated by two men, one controlling the machinery, the other adjusting the devices used to hold the lumber. The daily capacity of such a machine with a crane arm having a 32-foot span and a track length of 450 feet is approximately 150,000 board feet.

*Gantry Crane.*<sup>1</sup>—This type is especially serviceable in handling heavy timbers which are brought within reach by some other system. It is adapted to high piling and to loading cars and vessels.

<sup>1</sup> See Fig. 114.

It has two parallel straight tracks, elevated on heavy timber or steel structures, which may be spaced from 75 to 100 feet apart. The moveable cross-arm spanning the gap between tracks is a steel truss and on each end it has a pair of wheels which run on the elevated track.

A trolley carrying a hoisting drum, actuated by electric power, travels back and forth on the crane arm. One or more loading cables equipped with hooks or slings pass through the trolley and over to the operator's cage, which usually is located on one side of and at the end of the steel arm. The tracks on which the arm travels often are several hundred feet long. The crane spans the loading track, the delivery end of the live rollers or other devices used to bring the lumber within reach, and also the storage space for timbers on lumber. The elevated tracks extend to the end of the wharf when the crane is used for loading vessels. It may be used for assorting lumber or timbers, for stowing them in piles, and for loading.

A modification of the Gantry type of crane has been developed for loading and unloading vessels, which spans both the lumber storage tracks and the slip in which a vessel is berthed.<sup>1</sup> The crane arm or bridge is supported on a trussed leg with flanged-wheels which travels on a track laid on the dock floor and parallel with the vessel slip. The other end is supported on an elevated track on the opposite side of the slip. In one machine, the crane arm was 130 feet long, 12 feet wide, and 10 feet high and not only spanned the loading tracks and the vessel slip, but also projected 38 feet beyond the movable leg over a 22- by 42-foot counter-balance weighing about 25 tons. This counter-balance was mounted on trucks traveling on a track at right angles to the slip. A section of the rail on which the movable leg traveled was also mounted on the carriage of the counter-balance, and when vessels entered or left the slip the crane arm was withdrawn by running it on the section of track carried by the counter-balance. The crane arm was then lifted from the elevated track, by means of a block and tackle rigged on the counter-balance, and the latter was then withdrawn in a direction at right angles to the slip, carrying the crane with it. Two cranes of this type have loaded 1,600,000 board feet of lumber on a vessel in ten hours.

*Locomotive Crane.*—These are built in a variety of types for handling lumber and timbers in storage yards and for loading them on cars or in vessels. They are used extensively for handling large timbers, although lumber packages containing from 1000 to 2000 board feet also are frequently moved.<sup>2</sup> It is the type of crane preferred by many because of the variety of purposes for which it may be used; such as moving

<sup>1</sup> See American Lumberman, Nov. 11, 1911, pages 80, 100, and 101.

<sup>2</sup> A similar type of crane used for handling logs is shown in Fig. 7.

lumber and timbers direct from the mill to the storage yard, car or vessel; piling lumber and timbers in the storage yard; and spotting cars for loading and unloading.

The track on which it travels requires no more space than that of a standard-gauge railroad, and the cost and maintenance of the road bed is less than for the overhead types of cranes. They range in capacity from 5 to 10 tons and in ten hours can handle from 90,000 to 125,000 board feet from the assorting table to the yard, depending on the size and length of lumber and the care with which it must be placed on the pile. When lumber is moved direct to shipside, 170,000 board feet may be handled in ten hours, provided the length of haul is not more than a few hundred feet. A crew of two men usually is employed. A crane used for piling ordinary length lumber in a yard has a 45-foot boom. The life of the locomotive crane is said to be from twelve to twenty years.

### **Rollers and Chains.**

Live rollers and endless chains or cables are used around many sawmill plants to convey lumber and timbers to the loading dock or to storage sheds. These do not differ from the same class of equipment used for handling the product in the mill. Their use is not as common as the other forms of equipment previously mentioned.

### **Cableway System.**

Equipment designed along the lines of overhead logging systems has been used to convey lumber across streams or other places where it was not practicable to install the usual forms of lumber-handling equipment. One such installation<sup>1</sup> which was made in the Northwest some years ago spanned an inlet, on one side of which was located the sawmill and on the opposite side a storage yard from which rail shipments were made. The total span was 1176 feet, the head tower being 100 feet and the tail tower 90 feet in height, both constructed of wood.

The line had a rated capacity of 5 tons, the usual load being approximately 1000 board feet of lumber. The capacity per hour was 15,000 board feet. Loaded two-wheeled lumber buggies were picked up at the assorting table by cables suspended from a traveling trolley and deposited at the proper yard runways on the opposite side of the inlet. The system also was used to load lumber, both on scows and on cars. The hoisting speed of the device was 250 feet, and the traveling speed 1200 feet per minute. While such equipment is not common, it has proved useful in meeting special conditions.

<sup>1</sup> See *The Timberman*, October, 1910, page 58.

### Lumber Sky-line.

Another type of aerial lumber-handling equipment, known as the Clark-Nickerson Lumber Sky-line, has been designed after systems used to handle heavy timbers and metal parts in ship yards. So far, it has been installed only at plants which ship a large proportion of their cut by water and which require maximum lumber storage capacity in a minimum space during the time a cargo is being assembled.

Four masts of equal height, usually from 100 to 150 feet, are set one at each corner of a rectangle<sup>1</sup>, each one being guyed with three

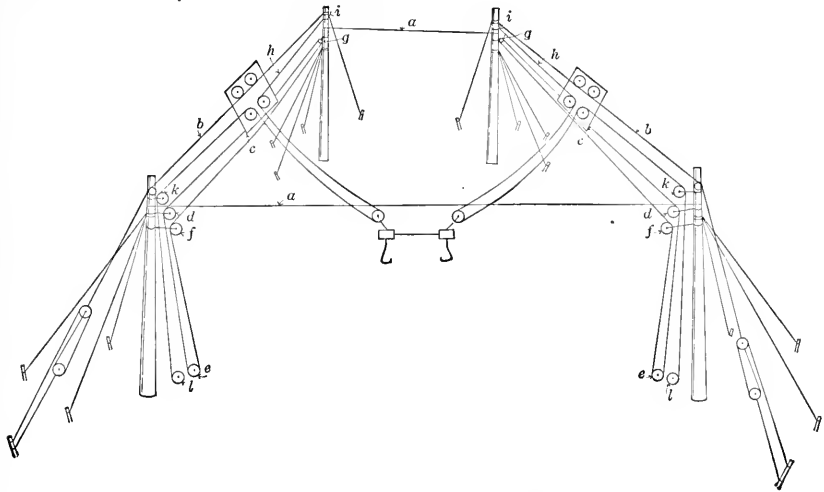

FIG. 115.—A Clark-Nickerson Lumber Sky-line showing the Arrangement of the Masts and Cables. *a, a.* Guy Lines. *b, b.* Cables supporting the Trolleys. *c, c.* Points of attachment of the Shifting Lines to the Trolleys. *d, f,* and *g.* Blocks through which the Shifting Lines run. *e.* Electric Winch operating the Shifting Line. *h, h.* Hoisting Lines. *i, i.* Points of attachment of the Hoisting Lines to the Masts. *k, k.* Blocks through which the Hoisting Lines run to the Electric Winches, *l, l.*

$1\frac{1}{2}$ -inch cables, which are grouped around it, outside of the rectangle, in an arc of 120 degrees. The two masts at each end of the rectangle are connected by a cable, Fig. 115*a*, which is drawn taut by means of the guy lines. The masts on each side of the rectangle are connected by a  $1\frac{1}{2}$ -inch cable, Fig. 115*b*, drawn taut by a block-and-fall, and on each of these cables a two-wheeled trolley travels. Each trolley is shifted along the main cable by a  $\frac{1}{2}$  inch line which is fastened to the trolley at *c*, Fig. 115. It passes from the trolley through a block

<sup>1</sup>The size of the rectangle depends on the storage space required, and may be as large as 180 by 800 feet.

on the mast at (*d*) around an electric winch at (*e*), up to and through a block on the mast at (*f*), through a block on the opposite mast at (*g*), then back to the trolley to which it is attached. Both of the winches operating the shifting cables are controlled by one lever, so that they act simultaneously, thus keeping the trolleys always opposite each other.

The hoisting rig consists of a  $\frac{1}{2}$  inch cable (*h*), one end of which is fastened to the mast at (*i*). The other end passes through the trolley as shown in the figure, then through the mast block (*k*) and down to an electric winch (*l*). The hoisting cables are connected by a 10-foot bar with weights on each end. Hoisting hooks are suspended from the ends of the bar, and blocks for the hoisting cable are attached to the upper side of the bar as shown in Fig. 115.

The hoisting cables have an independent control in order that the spreader and hoisting hooks may be shifted from side to side as well as along the main cable, thus enabling the operator to cover the entire area within the rectangle.

Lumber is brought to the storage area on trucks, a cable is then thrown around the load and the latter carried to the storage point. When the lumber is to be loaded on a vessel, the truck-load unit is again picked up, carried to a truck and hauled to a loading point. The storage capacity of a yard of this character is limited only by the height of the masts, and by the weight which the dock will support. It is practicable to make the lumber piles 60 feet high, when the suspension-cable elevation is 100 feet.

### Small Rail Cars.

Lumber is taken from the assorting table to the yards or to other parts of some plants on small four-wheeled cars or trucks running on light rails, either wooden or steel, usually the latter. These may be hauled either by animals or by small locomotives. Each car carries from 1000 to 1500 board feet and the usual method of loading is to place the cars along the assorting table and at right angles to it so that the lumber can be placed on them as it is pulled from the table. The cars, when loaded, are either run upon a turn-table and switched to a main track running parallel to the assorting table and then hauled away, or they are run upon a transfer car, by means of which they may be carried to some transfer point and shunted to a parallel track running to the storage yard runways.

This method lacks the flexibility of animal- or tractor-drawn lumber buggies and is not in extensive use. Where small cars are used, locomotives with steam, gasoline, or electric power may replace animal

draft. Gasoline or electric locomotives are preferred because of their greater efficiency and safety.

One of the most extensive electric systems is in use at a plant in Idaho, at which both the green and the dry lumber are handled by this method. More than 50 miles of track are in use, covering all portions

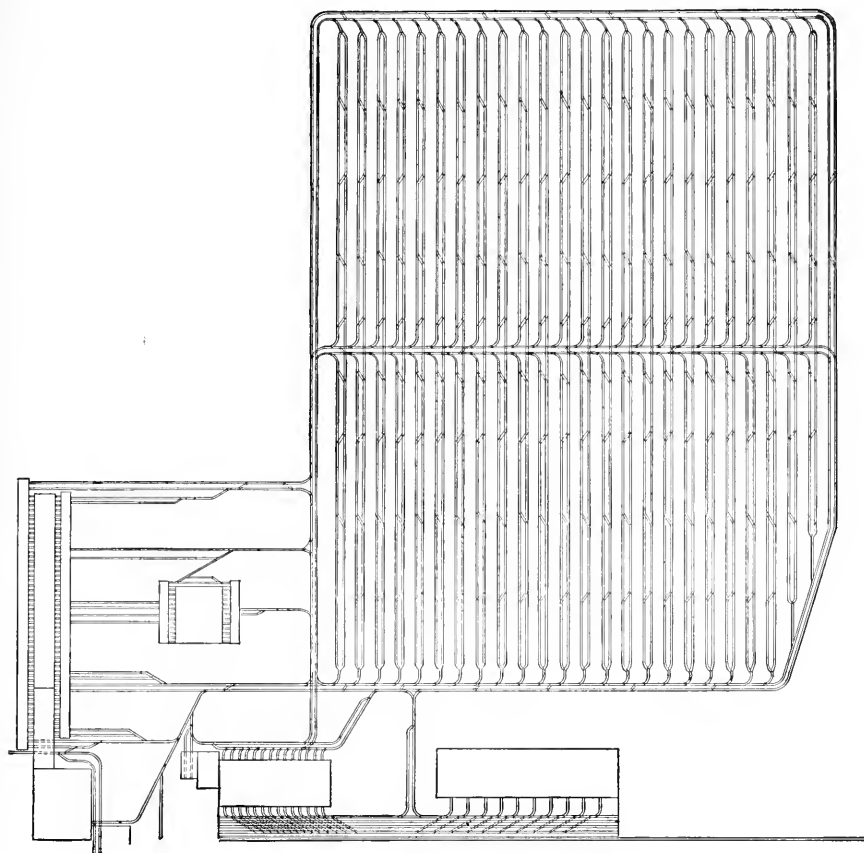

FIG. 116.—The Track System used at a Western Sawmill Plant for distributing Lumber by Small Rail Cars and Electric Locomotives. The Sawmill is shown in the Lower Left-hand Corner, the Planing Mill in the Front Center, the Dry Lumber Storage Sheds at the Right, and the Dry Kilns above the Planing Mill.

of the plant.<sup>1</sup> The locomotives, which are of 7-ton capacity, derive their power from storage batteries, and can handle a train load approximating 70,000 board feet. One locomotive<sup>2</sup> of this type has done as much as 450-ton-miles per day of ten hours, on hauls averaging

<sup>1</sup> See Fig. 116 for general arrangement of the track system.

<sup>2</sup> See Fig. 117.

$\frac{3}{4}$  mile. The batteries are recharged daily, usually at night, but when worked to capacity a short extra charge may be necessary at noon.

Electric locomotives with overhead trolley attachment instead of batteries are used when it is practicable to supply current to the entire track, although the many switches and sidings usually required at a

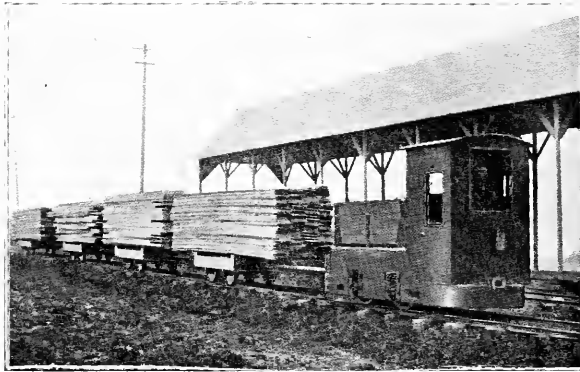

*By permission Jeffrey Mfg. Co.*

FIG. 117.—A 7-ton Locomotive operated by Electric Storage Batteries.

lumber manufacturing plant necessitate a complicated trolley wire construction which often is a source of annoyance.

Gasoline locomotives of several types have been put on the market, but they have not been as extensively adopted as those driven by electricity.



## CHAPTER VII

### THE SAWMILL POWER PLANT

#### SMALL MILLS

##### **The Building.**

Portable sawmill plants remain only for a short period at a given set-up and, therefore, shelter for the equipment is frequently lacking. However, a crude shelter may be erected, if the operation is conducted during the season of inclement weather. Small semi-portable plants which remain at one setting for a long period have a more permanent form of shelter which often is inclosed on the sides. Permanent plants of small capacity are housed in one-storied buildings of substantial construction, one roof usually covering both the power plant and the sawing machinery. There is such a great variation in the form of the structures that no one type can be considered typical. The chief requisite is a shelter that will protect the machinery from the weather and permit operation at all times.

##### **Power.**

Most small mills, especially portable ones, are deficient in power because an effort is made to keep at a minimum the weight of the machinery that must be transported. Since the power machinery is heavy, the tendency is to purchase boilers that will barely meet minimum requirements. The power used often has not been designed primarily for sawmill use and may be diverted to other purposes during a portion of the year. Portable mills are frequently driven by a boiler and engine mounted upon wheels or skids. Traction engines often are used. Within recent years gasoline engines also have been used to some extent. The power developed by portable mill engines seldom exceeds 25 horse-power and frequently ranges from 16 to 20, which is barely sufficient to run such a mill when cutting average-sized logs.

The permanent type of small mill has greater power capacity, because once installed the problem of frequent movings does not enter into consideration. Even with such plants, however, the tendency to add additional equipment from time to time often leads to power demands which exceed the average capacity of the plant.

Stationary mills may use the same type of equipment, but often a boiler with a detached engine is installed. The boilers frequently have a brick setting, and have a rated capacity of from 30 to 50 horse-power, depending upon the amount of machinery to be driven. A Dutch-oven setting for the boilers of mills of from 10,000 to 20,000 board feet daily capacity was devised by the American forestry troops in France and proved very successful in improving the steaming qualities when sawdust and green slabs were used for fuel. They are desirable for small plants which remain four months or more at one setting.<sup>1</sup>

A short stroke, high-speed engine, operated at a high boiler pressure (150 to 175 pounds) is best for a portable mill, because the short stroke enables the engine to quickly recover from an overload, and a high-pressure boiler permits the development of the maximum power with the minimum weight. Center-crank engines<sup>2</sup> are preferred because they are better balanced on top of the boiler than side-crank engines and, therefore, are less liable to tip over on rough roads. They also make possible the installation of pulleys on both ends of the drive shaft, so that both a head-saw and a slab-saw can be operated at one time.

Small permanent plants use some form of slide-valve engine mounted on suitable skids or on a foundation placed near the boiler.

The locomotive type of boiler is the one in most common use with portable outfits. The Cornish type of boiler is preferred by some because it has a long fire box which will take slabs 6 or 8 feet in length.

When a standard type of setting<sup>3</sup> is installed at permanent plants a horizontal tubular boiler with a half-arch or full-arch front is used, the fuel being both sawdust and slabs.

Auxiliary boiler equipment, such as steam feed pumps, and water heaters are not in use, reliance being placed on injectors for boiler feed and the water being introduced into the boiler at its natural temperature.

Where water power is available, the machinery may be driven either by a water wheel or by a turbine. Water-power drive for small mills usually necessitates low speed and reduced capacity because there often is an inadequate water supply at some seasons.

The overshot, breast, and undershot wheels have largely been supplanted by some form of turbine, because of its greater speed and efficiency. The Pelton turbine, an axial impulse form, is preferred for this purpose because of its simplicity of construction. This type of turbine is driven by a jet of water striking on a series of buckets, in the form of two hemispheres joined together at the center by a mid-rib. The

<sup>1</sup> The general design of this equipment is shown in *The Timberman*, March, 1920, page 42.

<sup>2</sup> See Fig. 11.

<sup>3</sup> See Fig. 118.

water striking the rib is divided into two streams, one going each way. The outlet of this type of turbine is always above the water level of the tail race and the wheel is never filled with water.

The "reaction" type of turbine, similar in appearance to the impulse type, differs from it, in that the vanes are always full of water and the discharge is under the water level of the tail-race. This type, although more complicated in structure will furnish greater power, with a given head of water, than the impulse type.

### **Fuel.**

The fuel used in portable plants consists largely of slabs, either in short or long lengths. Sawdust is used only to a minor extent because it does not burn readily under the type of boilers generally used. Coal is sometimes substituted for slabs when the latter have a high sale value as wood fuel.

In small permanent plants both slabs and sawdust are used. The standard type of boiler with brick setting permits the use of suitable grates and ample grate space for burning sawdust and other fine refuse. Mechanical stoking devices are rarely used, the sawdust being shoveled into the combustion chambers. Sometimes the sawdust has a sufficiently high sale value to warrant disposing of it for various commercial purposes.

## LARGE PLANTS

### **The Building.**

The housing for the power plant at a large sawmill operation includes an engine room, a boiler room, and a fuel storage house. These may be combined under one roof, but frequently the fuel house, which is large enough to hold several days' supply, is a separate structure. The engine room and boiler room are often placed under the same roof, but in separate rooms. The building is separated from the sawmill proper by a fireproof wall, as a measure of fire protection. The power buildings are fireproof in character and have brick or concrete walls, steel-beam rafters, and a galvanized-iron roof.

Auxiliary equipment such as wells, reservoirs, and fire pumps are placed at convenient points around the plant often in a building of non-combustible character.

### **The Motive-power Equipment.**

Although there are occasional instances where lumber companies purchase electric power for driving their plant, the usual practice is

to develop it, using the mill refuse for fuel. The motive power used in large sawmill plants which develop their own power ranges from the simple slide-valve engine to the most modern type of compound Corliss engine or low-pressure steam turbine, the latter driving a direct-connected dynamo.

The shaft-and-belt drive is the more common form of applying power to the machines although electric motor drive is rapidly being introduced into large mills.

The Corliss type of engine is installed in modern sawmills using the shaft-and-belt drive, one engine driving the greater part of the machinery, although auxiliary engines may be used for the sash-gang mill or for some of the lumber transfer equipment. The main and auxiliary shafts and much of the belting are placed on the ground floor of the sawmill where it is accessible, yet out of the way of workmen on the sawing floor.

Chain drives are used chiefly for lumber transfer devices. Friction drives are used where it is necessary to reverse the direction of travel such as in lines of live rollers, or where power is thrown on and off at frequent intervals, such as with log jacks.

The main shaft for a band mill runs through the center of the ground floor of the mill parallel to its length, while that for a circular head-saw runs at a right angle to the main axis of the building. The amount of shafting on the ground floor of two mills having the same equipment may vary widely. In a southern yellow pine mill, having two band head-saws and the other necessary standard equipment, 337 linear feet of shafting, varying in diameter from  $4\frac{1}{8}$  to  $1\frac{5}{8}$  inches, were used on the ground floor and 106 linear feet of shafting, chiefly  $1\frac{5}{8}$  inches in diameter were used on the sawing floor.

Many cast-iron and wooden split pulleys are required, also bevel frictions and various types of gears. A mill with a ten-hour capacity of 100,000 board feet and equipped with a shaft drive, requires approximately 2300 linear feet of belting from  $1\frac{1}{2}$  to 38 inches in width. Mills of the same capacity having motor drive require about 800 linear feet. The annual maintenance and replacement cost of belting is from 15 to 25 per cent.

The engine power required to drive a sawmill is dependent on the machinery installed, the amount of shafting and belting used, and the condition of the shaft bearings and the various driven mechanisms. Mills cutting small- and medium-sized softwoods require the least horse-power while those cutting large timber and hardwoods require the most power. A sawmill cutting 100,000 board feet or more per day, requires from  $4\frac{1}{2}$  to 8 horse-power for each 1000 board feet manufactured in ten hours. However, two sawmills having the same rated

capacity may vary greatly in their power requirements because of the difference in character and size of the logs sawed and the kind of products manufactured. Thus less power per thousand board feet output is required to cut a given set of logs into timbers than into 1-inch boards, because less work is performed; also dense hardwoods require more power in their manufacture than the softer woods.<sup>1</sup>

The loss of power in shaft drive, due to friction and other causes, is from 25 to 30 per cent, even in those plants in which the maintenance standards are high.

Rope drive was substituted for the main belt drive in a few plants, some years ago, but installations of that character have been rare in recent years.

Electric power was first successfully applied to driving sawmill machinery about the year 1906. The substitution of motor-drive for shaft-drive in large mills, especially for those machines which require a large amount of power, has increased greatly in recent years. While there is some loss of efficiency in power transmission by this method, it is a more economical form than shaft-drive because the power loss in transmission due to belt slippage and friction is less. Some place electric-drive efficiency as 15 per cent higher than shaft-and-belt drive.

The chief advantages of electric-drive for a mill plant are:

- (a) Saving in power requirements.
- (b) Reduced maintenance costs for belting, oils and worn-out bearings, due to the elimination of much belting and shafting and many boxes and hangers.
- (c) Reduction in the insurance rates, because of reduced fire risk.
- (d) Reduced labor costs, because fewer millwrights and oilers are required.
- (e) Reduction in lost time, due to fewer shut-downs caused by disabled machinery.
- (f) Reduction in labor and equipment since independent engines and engineers are not required for auxiliary plants, such as planing mills.

Alternating currents predominate in sawmill practice, a three-phase sixty-cycle, four hundred and forty volt current being almost universally used, because of the relatively short distance of transmission and the ease of insulating the wires. A sixty-cycle frequency current has been found the most satisfactory.

The induction type of motor is especially adapted to electric drive in sawmills because practically all machines run at constant speed and are subject to heavy and sudden overloads; they are simple in structure,

<sup>1</sup> See Electrically Driven Sawmills. By Allan E. Hall. Southern Lumberman, Dec. 18, 1920, page 202.

having no brushes or commutators; when started they do not require synchronizing, hence are more easily cared for; and the general cost of maintenance is less than for other types of motors.

The power requirements of the different machines in a sawmill vary with each individual installation as it is governed by the size, length, and kind of logs sawed, the rate of cutting, and the condition of the timber.

Some forms of equipment such as band head-saws, log-jackers, long conveyors, or lines of live rollers which require frequent reversals, need a great turning power or "torque" to start them and necessitate the use of a different form of motor. The squirrel-cage induction motor has insulated copper wires wound on the rotor and by introducing resistance in the coils on the rotor, an increased torque can be obtained to start the machine. The resistance is withdrawn when the motor has reached full speed. A squirrel-cage type of induction motor with welded rings is used for circular head-saws, edgers, trimmers, and slashers which require only a moderate starting torque, but which are subject to occasional heavy overloads. They are simple in structure and will stand much abuse.

Steam is superior to any other form of power for certain types of equipment such as a short carriage feed, and the log-turning devices.

The range of horse-power required to drive the more important machines and equipment in a sawmill<sup>1</sup> is as follows:

<i>Equipment.</i>	<i>Horse-power required.</i>
Log jacker .....	20- 50
Circular cut-off saw.....	25- 50
Head-saw, circular.....	100-150
Head-saw, band.....	100-300
Band resaw.....	75-150
Sash-gang mill.....	50-300
Edger.....	50-200
Trimmer.....	20- 60
Slasher.....	30- 75
Live rollers (each).....	0.25-0.4
Conveyors.....	10-50
Jump saws.....	10- 15
Refuse grinders.....	25-150

The larger machines are equipped with individual motors, but transfer rollers, transfer chains, conveyors and other equipment which requires approximately the same amount of power, whether running idle or working, may be grouped and several of them driven by one motor.

<sup>1</sup> The size of the machine and the character and amount of work to be performed cause a marked variation in the horse-power required.

### Lighting System.

A large sawmill plant requires lighting facilities not only for the sawmill and power house, but also for yards, sheds, office, commissary, and dwellings. Electric light is most feasible for this purpose and presents a lower fire hazard than any other form of illumination. A large plant, therefore, whether equipped with shaft-drive or electric-drive is provided with a lighting plant, the capacity of which is dependent upon the general plant requirements. The sawmill lighting plant in some cases furnishes electric power, under contract, to adjacent villages or cities. The type of plant is similar to commercial lighting plants of the same size.

### The Steam-producing Equipment.

Provision must be made not only to furnish an adequate supply of steam to drive the motive power of the sawmill, but also to supply the dry kilns, steam carriage feed, steam set-works, steam log turners, and other steam-operated devices. Two hundred or more boiler horse-power, over and above engine requirements, must be developed for these purposes. Standard-size progressive dry kilns require from 40 to 50 boiler horse-power each, while a mill having two head-saws will require about 100 boiler horse-power for the various steam cylinders.

Horizontal tubular boilers arranged in batteries of from two to four are in frequent use in large plants. A common size is one which is 72 inches in diameter and 18 feet in length with seventy 4-inch tubes. Such a boiler has a rated capacity of approximately 150 horse-power. The steam pressure is 125 pounds per square inch, though in some cases 150 pounds pressure is carried. Both horizontal and vertical, high-pressure, water-tube boilers have been installed in some plants in recent years, and are regarded as more effective steam producers than the horizontal tubular type.

There are two types of boiler settings known as the "standard"<sup>1</sup> and the "Dutch-oven."<sup>2</sup> The fire box in the first type is placed directly under the boiler shell or tubes, while in the Dutch-oven type an extension front is built which gives a larger fire-box and provides better combustion with wood fuel.

The standard type may have either a "half-arch," "three-quarter" arch, or a "full-arch" front. In the half-arch and the three-quarter arch type, the smoke box projects beyond the boiler front, whereas in the full-arch type the end of the smoke box is enclosed by the boiler front. When the standard setting is used at plants burning sawdust for fuel, a larger grate surface must be provided than would be necessary

<sup>1</sup> See Fig. 118.

<sup>2</sup> See Fig. 119.

with coal or wood fuel. There is a burning surface greater than the grate area when fuels such as coal and wood are used because the fire

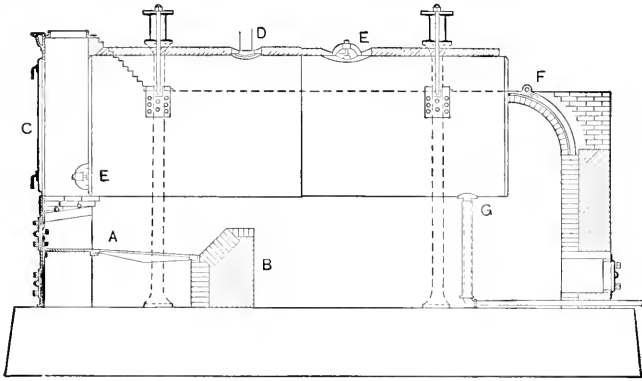

FIG. 118.—A Standard Type of Horizontal Tubular Boiler with a Full-flush Front. *A.* Grates. *B.* Fire Wall. *C.* Door to Smoke Chamber. *D.* Steam Pipe to Main Header. *E, E.* Clean-out Holes. *F.* Rear Arch. *G.* Blow-off Pipe.

burns more or less throughout the mass. Sawdust, on the other hand, burns only on the surface and hence for a given grate surface coal or wood will produce more heat than sawdust fuel.

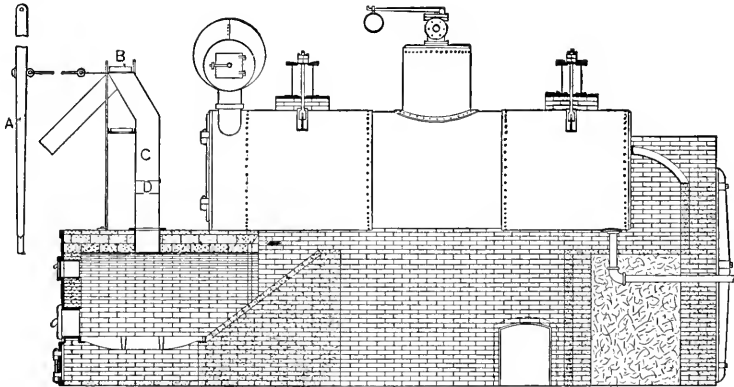

FIG. 119.—A Dutch-oven Boiler Setting with Automatic Stoking Apparatus. *B.* Conveyor Trough from the Fuel House. *C.* Metallic Chute from the Conveyor to the Furnace. *D.* A Tilting Damper. *A.* Lever attached to a Slide by means of which the Flow of Wood Refuse into *C* may be stopped.

The Dutch-oven type of boiler setting is in common use at sawmill plants where fine wood fuel is used, because it affords a larger combustion chamber than is practicable with the standard setting. Another advantage of this type is that the furnace may be placed far enough away from the boiler heating surface so that the heat available for



steaming purposes is from completely burned fuel. In a standard setting, with the fire directly under the boiler shell, gases still in a state of combustion strike the relatively cold heating surface of the boiler and this retards the combustion process and causes soot deposits.

The grates used in the combustion chamber of sawmill boilers are of the fixed type, that is, they are not shaking grates since there is no clinker accumulation as in the use of coal. The grates are single bars placed side by side in the furnace, and supported at the ends by lugs which rest on suitable foundations. For long furnaces, such as the Dutch-oven type, the grate bars are made in two lengths supported in the middle by a bearing bar. Large grates often slope towards the bridge wall at the rate of  $\frac{3}{4}$  inch for each foot of grate length. Narrow air spaces must be used in a grate for burning fine fuel, such as sawdust. The herring-bone grate bar, Fig. 120, has been adopted to overcome the warping and twisting common to straight bar grates. This grate is subject to a minimum of warping because the angular form of the cross pieces of the bar permits free contraction and expansion of the metal.

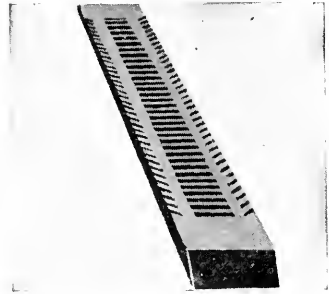

FIG. 120.—A Herring-bone Grate Bar for Sawdust-burning Furnaces.

Forced draft is used under boilers at sawmill plants where difficulty is experienced in producing sufficient steam with natural draft. It usually is not necessary if the boiler plant has been designed properly, and if excessive steam demands are not made upon a given unit. In many cases, the area of grate surface is insufficient to permit the requisite consumption of sawdust fuel, or the stack is not large enough to insure an adequate draft, or an attempt is made to secure more power from the boilers than they were designed to produce. Most mills that install forced draft do so from necessity rather than from choice.

Forced draft is in more common use in mills cutting hardwoods than in those cutting softwoods because wet hardwood sawdust does not burn readily and often there is no dry planing mill refuse which can be mixed with the fuel. Another reason for their use at some plants is that it is cheaper to put in forced draft than it is to build a chimney or stack of the size required for natural draft. Forced draft permits the use of a smaller chimney or stack and a reduced grate area because the air can be forced through the grate at a higher velocity than is attainable with natural draft.

The equipment comprises some form of blower fan which furnishes

air under forced draft to the fire through a special form of hollow grate, one type of which is shown in Fig. 121. The surface of the grate bars

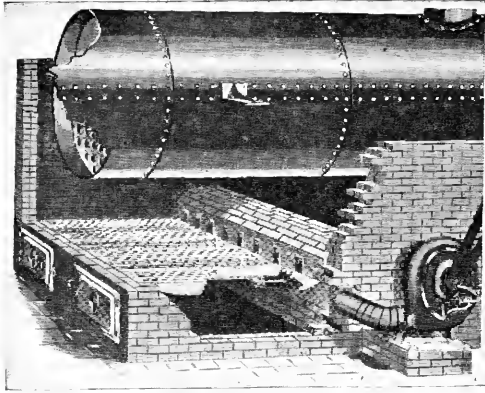

*By permission Gordon Hollow Blast Grate Co.*

FIG. 121.—A Form of Forced Draft Equipment adapted to burning Sawmill Refuse.

are flat and have small rectangular holes cut in their surface through which the air passes.

Another type of forced-draft grate, known as the griddle-bar grate, has several circular lids or tuyeres, 7 inches in diameter, which are seated on a shoulder cut into the grate bar surface. The tuyeres have outlets on their rims through which the forced draft passes. The griddle bars are alternated with some form of grate bar

which permits air to pass from the ash pit into the combustion chamber, and also permits ashes to drop through the grates.

In addition to the equipment mentioned a "mud drum" is required under the boiler for collecting boiler sediment; a steam drum above the boiler for the collection of dry steam; a safety and a blow-off valve; a steam gauge; a water gauge; one or more injectors; and a smoke box.

Auxiliary boiler house equipment consists of steam feed water pumps and a water heater. The latter is usually placed near the engine exhaust from which steam for heating feed water is obtained. In some cases hot feed water is drawn from a water jacket surrounding the refuse burner.

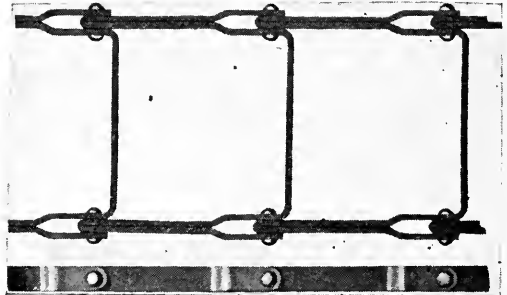

*By permission The Prescott Co.*

FIG. 122.—A Box or Drag Chain used for moving Sawdust, Slabs, and Other Refuse.

*Mechanical Stoking Devices.*—The stoking of boilers in all modern sawmill plants is done largely by mechanical means. The conveyors which carry the sawdust away from the sawmill pass through the boiler house in front of or above the boiler fronts. These conveyors

terminate in the fuel house where surplus fuel is stored both for daily use and for those periods during which the main plant is shut down, such as nights, Sundays, and holidays. The conveying system sometimes is arranged so that fuel may be fed, through chutes, directly to the furnaces from the main conveyor. However, a better practice is to have an independent conveyor system running from the fuel house to the boilers. The fuel conveyor comprises of two square or rectangular metal troughs <sup>1</sup> placed one above the other in which a conveying chain travels, one type of which is shown in Fig. 122. This chain, driven by a sprocket wheel placed near the fuel house terminal, passes over an idler at the opposite end of the conveyor. A second conveyor extending from the fuel house to the boiler room has chutes which lead to the openings in the Dutch-oven or to the combustion chamber in a standard setting, and through which fuel is fed into the fire box. A lever-operated gate in the chute enables the fireman to control the amount of fuel which passes into the combustion chamber.

<sup>1</sup> See Fig. 119.



PART II  
LUMBER MANUFACTURE



## CHAPTER VIII

### LABOR

THE lumber and timber products industry<sup>1</sup> in 1914 ranked first, among all industries in this country, in the number of persons engaged, exceeding by 20 per cent, those employed in the manufacture of foundry and machine shop products.<sup>2</sup>

Although there have been many mechanical devices perfected for use by the industry there is a large amount of hand work still connected with the production of lumber, the greatest part of which calls for semi-skilled or unskilled laborers.

### CHARACTER

The workers engaged in lumber manufacture in each region are usually of the same nationality as those engaged in logging, since laborers shift from one to the other when conditions of employment become more favorable. Workmen frequently are employed on logging operations during the late fall and winter and in the sawmills during the open season in those regions where logging is seasonal in character, such as in the Northeast, in the Lake States, and in the Inland Empire.

There is a tendency for greater specialization in the South and in the Northwest where both logging and milling are carried on throughout the year. The tendency to change employment is more common in those regions in which men are housed in bachelor quarters in a logging camp, since they find it easier to change occupations than men who have their families established in the logging camp.

French Canadians, some native Americans, and also men from the southern countries of Europe comprise the sawmill labor in the Northeast. Finns, Poles, Swedes, and Norwegians predominate in the Lake

<sup>1</sup> This includes logging camps, sawmills, and planing mills operated in connection with sawmills.

<sup>2</sup> The number reported by the Bureau of the Census for the year 1914 was 536,116 persons, 480,207 of whom were wage earners. See Abstract of the Census of Manufactures, 1914. Department of Commerce, Bureau of the Census, Washington, 1917, Table 220, pages 534 and 536. Preliminary statistics for 1919 show a total of 533,935 of whom 480,945 were wage earners.

States. On the West Coast there are many laborers from the North of Europe, some from the South of Europe and from Asia, and a limited number of native-born Americans. Native-born whites and negroes comprise the greater proportion of the labor employed in the southern mills, although many Mexicans may be found at plants near the southern border.

The laborers are a sturdy type and do not leave the industry, as a rule, even though they may move from one operation to another. However, large numbers were attracted to other lines of work during the war because of the higher wages paid. With many, however, this shift was temporary, and they are gradually drifting back into some form of forest work.

The lumber industry in common with other large industries has suffered during the last few years from industrial unrest. The demand for higher wages, shorter hours, and better living conditions has been most pronounced in the Lake States, the Inland Empire, and the Northwest, where labor organizations have been able to unionize the men. The 8-hour day became a reality in the West during the latter part of 1917. Higher wages and better living conditions have been realized, to some degree, in every region.

#### HOUSING AND SOCIAL WELFARE

There is no standardized system of housing sawmill employees throughout the country, the conditions being similar to those found in every type of industrial community. When the plant is located in an old established settlement, the labor is drawn chiefly from local residents, and the operator has little concern with the housing conditions of his employees. They live chiefly in their own homes or in rented houses in which the company has no financial interest. Many sawmills are erected, however, in regions where there are no settlements and in such cases the plant equipment must include dwellings for the employees. This represents a heavy initial expenditure, since a large plant requires several hundred homes. The usual type of dwelling at a modern plant is one with from four to six rooms equipped with running water, electric lights, and modern sanitary appliances. These buildings are rented to workmen for a nominal sum sufficient to cover interest charges, depreciation, and maintenance.

When a sawmill is established in an old settled community, the lumber operator seldom has control of the laborers, outside of working hours. However, in those communities in which sawmilling is the only industry and the dwellings are owned by the lumber company, the latter exercises the police powers, of the community. Such towns,



known as "one-man" towns, may be found in practically every forest region, but are more common in the South than elsewhere.

The desirability of control of the administrative affairs of a community by a progressive company, at least during the early years, cannot be doubted. It frequently has been the case that the neighborhood, previous to the establishment of the plant, was dominated by an undesirable element which held in subjection the more law-abiding citizens. The administration of justice by impartial outside interests has broken up lawlessness and brought peace and prosperity to the community by the elimination of liquor, the suppression of vice, and the establishment of churches, schools, and other public institutions.

Many of the "one-man" towns are the most progressive ones in the region, because the pride of the management in its settlement and its interest in the laborers has led it to do more for the community than the older communities have been able or willing to do for themselves. As a consequence excellent schools, churches, hospitals, and club houses are found in many places, and in addition there are often minor industrial plants established which aid the rural residents in the vicinity to market their crops to advantage.

Much has been done in some places to raise the general standard of living by providing courses in domestic science not only for school children but also for adults; by the encouragement of thrift through the establishment of savings banks; and by providing wholesome amusements both for young and old. The lot of the average sawmill worker is now much better than it was formerly.

#### WAGES AND EFFICIENCY

The common method of paying sawmill workers is by the hour, day, or month; the hour system is the basis for the greater part of the force. Lost time exceeding one-fourth day is ordinarily not credited to those employees working on an hour or a day basis. Overtime is rarely paid to monthly employees except for special tasks, but is universally paid to others, usually on the basis of time and one-half. The time at which wages are paid is variable. Some mills now permit their employees daily to draw wages due while others have a weekly or semi-monthly cash pay day. Some states, by law, require at least semi-monthly payments. The issuance of token money is now prohibited in many states.

When weekly or semi-monthly pay days are the rule, employees are permitted to draw coupon books which are accepted in lieu of cash at the company stores. This avoids the credit system and also reduces the amount of cash which must be disbursed on pay days. Such cou-

pons are rarely honored unless presented at the company store by the owner of the coupon book or some member of his or her immediate family.

### **Piece Work.**

The present tendency among employers is to get away from the payment of a fixed wage for a given period and to devise some plan whereby the worker may be paid on the basis of the amount and quality of work performed (piece-work basis). There are some forms of labor connected with lumber manufacture which lend themselves readily to the piece-work basis such as pond work, including the raising of "dead heads," assorting lumber, stacking lumber on kiln trucks, and piling in sheds or on the yards. Other classes of work such as feeding planing machines and grading and trimming planing mill products, in some cases, have been placed successfully on a bonus basis. There are other classes of work, however, which are paid on the straight-wage basis; e.g., the payment of skilled and unskilled labor in the mill and around the plant which is not directly engaged in producing or handling lumber in units. The piece-work basis of payment for sawmill foremen, sawyers, edgemen, and trimmer men has been introduced in a few instances, but has not met with favor from most operators, who claim that it is not adapted to mills which manufacture a variety of species. The piece-work basis of payment for such labor, however, has a wider application than it has yet received and some form of it undoubtedly will be extensively introduced into sawmills within the next few years, because as wages increase some form of payment based on the amount of work performed must be adopted to maintain even an average degree of efficiency.

An example of the application of the piece-work basis to a portion of the sawmill labor is furnished by the scheme installed some years ago at a plant in Louisiana which was cutting cypress chiefly. At this plant, the sawmill foreman, sawyers, edgemen, and trimmer men were paid on the basis of quality and quantity of product produced, while yard piling and car loading were paid on a unit basis.

The mill had two head-saws and each side was equipped with an edger and a trimmer. Three men on each side, the sawyer, the edgerman, and the trimmer lever-man, all of whom influenced to a marked degree the quantity and quality of output, were paid a certain number of cents per thousand board feet for all lumber their side manufactured. A heavy premium was placed on high grades and nothing was paid for the very lowest grades. The cut of the mill was tallied and an accurate daily record kept of the output of each side. There was a

standing order that every log suitable for lumber must be utilized for that purpose in order that the sawyers would not cut uppers, only, from the outside of poor logs and send the defective portions to the shingle mill.

The enforcement of this rule rested with the sawmill foreman who was paid on the basis of the quantity of lumber produced, without reference to quality. When the mill shut down for one hour or more or when it was closed for annual repairs the foreman was paid on an hour basis—a reduction of about one-third over what he could earn when the mill was in operation. It was, therefore, to the interest of the foreman to secure output, while the attention of the remainder of the piece-work laborers was centered on quality. The men piling lumber in the yard were paid on the basis of the number of truck loads of lumber handled, and loading lumber on freight cars was paid by the thousand board feet on a contract basis with the inspector in charge.

The result of this method of paying laborers was an increase in the earning power of the men, an increase in the per cent of the higher grades produced, and reduced operating costs. The increase in efficiency as compared to day labor was due not so much to added labor performed as to the greater interest and intelligence displayed in devising easier and quicker methods of doing the work.

Objections have been made to the piece-work basis for the payment of sawmill laborers on the grounds that it tends to raise the level of day wages of those men not working on a piece-work basis; that the savings made do not always offset the increased cost of supervision; and that the accuracy of determining the quality and quantity of product turned out is dependent on the honesty of tallymen and graders, who consciously or unconsciously are inclined to favor the employee. There is a possibility of such an outcome to this system, but in those cases in which this method has been tried the advantages gained have more than offset any disadvantages which have arisen. The piece-work system is a logical one for such work and its introduction on an extensive scale may be looked for during the next few years.

### **Bonus System.**

An application of the bonus system to certain classes of planing mill work may be illustrated by the system inaugurated at a southern yellow pine plant which also manufactured some hardwood flooring. The objects sought in installing the following method were increased production and increased wages to capable workmen.

The basis of the system in the pine planing mill was a given daily

base output for each machine and the payment of a bonus to the machine feeder and to the grader for each one thousand linear feet manufactured over and above the base. The latter was established by examining the daily production records of individual machines over a period of several months and taking the mean of an average day's run and a high day's run as representing the amount of work for which the standard wage would be paid. At this particular plant, the standard day's work for a machine feeding at the rate of 300 linear feet per minute was 100,000 linear feet and for a machine feeding at the rate of 125 linear feet the base was 50,000 linear feet. The bonus paid in 1918 for all work above these bases was 3 cents per 1000 linear feet. While the base was relatively high the results are said to have proved satisfactory both to the company and to the employees concerned.

The system installed in the hardwood flooring plant differed in some respects from the one above described. Pine lumber, for the most part, is manufactured into standard sizes in the sawmill, while oak flooring strips are ripped from boards of varying widths and qualities and re-trimmed in the planing mill. The normal per cent of waste in making flooring strips is high and if the bonus system were based on production alone, the tendency would be to increase waste. The bonus system, therefore, was designed to decrease the normal waste rather than increase production. As a result of a year's effort to cut down the waste in the manufacture of flooring strips, the company found that a 22 per cent loss was the minimum attained, and they, therefore, took this as the base. The per cent of waste was calculated at the end of each month and each ripper and trimmer received \$1 for each 1 per cent reduction under 22 per cent which occurred during the period.

The men who operate the trimmers and end-matchers behind the flooring machines also receive a similar bonus for each per cent of saving effected below the base, the saving being the difference between the machine tally-meter reading and the amount, in linear feet, of flooring checked up by the tyers. The savings effected by this bonus system often amount to 11 per cent monthly, due to the greater care exercised by the workmen in saving stock.

A bonus system applicable to all workmen, both skilled and unskilled, has been tried at some southern plants with a reasonable degree of success. The basis on which the bonus is paid is continuous service. From 5 to 10 per cent is added, each pay day or sometimes at intervals of six months, to the wage of each worker who has been at work regularly. Some latitude is allowed with reference to absences, but a bonus is not paid to any one who, without good cause, fails to report, and who does not notify the proper person of his absence.

### Efficiency.

The labor required to produce one thousand board feet of lumber is influenced by the equipment of the mill, the size, character, and quality of the timber, the degree of utilization, and the efficiency of the labor. The latter factor is of prime importance and not only varies in the different regions, but also fluctuates with the labor supply and the wage rate.

The efficiency of sawmill laborers decreases with a wage increase because high wages are associated with a scarcity of labor and workmen are more restless and discontented and less interested in having permanent employment at one plant because of the knowledge that work can be secured readily at some other operation, at a possible advance in wage.

It is a common belief among lumber operators, and it is undoubtedly true, that the efficiency of woods and mill labor has decreased from one-third to one-half during the last decade. The conditions existing in the southern yellow pine region may be cited as an illustration of this. In July, 1914, the number of one-man hours required to produce one thousand board feet of lumber from tree to car was 23.3, while in July, 1919, 37.3 one-man hours were required to perform the same work. In 1914 it required 134 men on the payroll to maintain a full crew of 100 men, while in 1919, 153 men had to be carried to secure the same results. Neither the general class of labor employed nor the operating conditions in this region changed materially during this period. Some of the reduced efficiency may be attributed to the manufacture of lumber from smaller and more defective logs; to short-handed crews, a marked reduction in numbers in a crew usually lowering the per capita production; and to an increasing indifference in the attitude of the laborer towards doing efficient work. It is probably true, however, that the lumber industry has not suffered more from the laborer's attitude toward his work than have many other large industries.

The most extensive study which has been made of the efficiency of labor in the lumber industry is that of the Bureau of Labor Statistics.<sup>1</sup>

The number of one-man hours required to produce 1000 board feet of lumber from tree to pile is shown in a comparative way, for individual mills in Fig. 123. Logging represented 71.9 per cent of the total productive labor required on the hardwood operation; 63.8 per cent on the western yellow pine and larch operation; 62.7 per cent on the Doug-

<sup>1</sup> See *Wages and Hours of Labor in the Lumber, Millwork and Furniture Industries, 1915*. U. S. Department of Labor, Bureau of Labor Statistics. Bul. No. 225, Washington, Feb., 1918.

las fir operation; 61.9 per cent on the shortleaf operation; 60.8 per cent on the cypress operation; and 55.7 per cent on the redwood operation. The total productive labor required to produce 1000 board feet of mixed hardwoods (the highest) from tree to pile was 44 per cent greater than for redwood (the lowest). One operation in each group is not sufficient to establish the actual difference in labor required but it does indicate the relative status of the labor requirements.

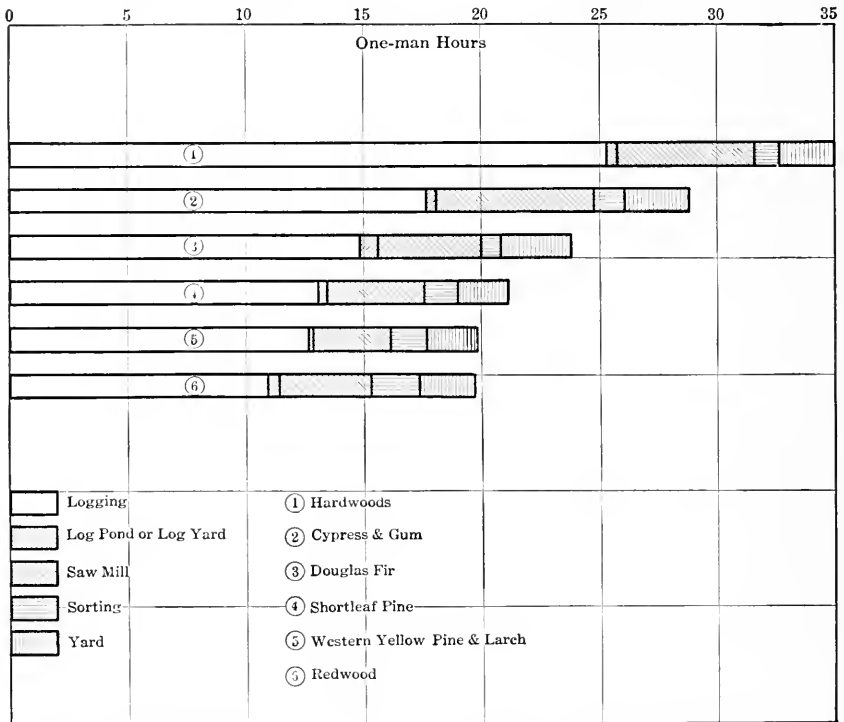

FIG. 123.—The Number of One-man Hours required to produce Lumber from Tree to Pile.

The logging cost of these operations, based upon the wage rates paid at the plants and the labor required, represent 69.4 per cent of the total at the shortleaf mill; 66.8 per cent at the hardwood mill; 66 per cent at the Douglas fir mill; 63.3 per cent at the western yellow pine mill; 58.6 per cent at the redwood mill; and 57.5 per cent at the cypress mill. The difference in cost between the highest (hardwoods) and the lowest (redwood) total labor costs was 20.9 per cent; the difference between the highest (hardwood) and the lowest (redwood) logging costs was 30.5 per cent; and between the highest (cypress) and lowest (shortleaf) manufacturing costs was 33.3 per cent.

Lumber manufacture from the pond to the pile requires from 28.1 to 44.3 per cent of the one-man hours required to produce 1000 board feet of lumber, and the range in cost of this labor is from 30.6 to 42.5 per cent of the total labor cost from tree to pile.

The average hourly board foot-output per man from pond to pile for the cypress operation was 89; for eastern spruce, 111; for mixed hardwoods, 119; for southern yellow pine, 124; for redwood, 124; for eastern hemlock, 128; and for Douglas fir, 134. The average for all was 128 board feet per man per hour. Dry kiln work in certain Douglas fir operations showed an output per man per hour of from 300 to 500 board feet, in western white pine 333, in redwood 350, and in mixed hardwoods 442.

In certain planing mill establishments, the hourly output per man ranged from 350 to 750 board feet, the average being between 650 and 700 board feet.

The relation between the total one-man hours required to produce 1000 board feet of lumber from pond to pile and the time required for the performance of given tasks is shown in Table II. These data represent weighted averages for mills in a given region, and disclose a striking similarity in all regions in the per cent of the total time required to perform a given task.

The chief time-consuming operations in the manufacture of lumber from pond to pile are yard work, assorting, and sawing. The sum of these three, for the average, represent 57.7 per cent of the total one-man hours required.

The table shows the variation in time required for given operations for 6 classes of timber, in addition to the totals. The variations are due chiefly to the average size of log, species, degree of utilization, and the character of the manufacturing facilities. More labor is involved in producing 1000 board feet of lumber from small logs than from large ones because the time required for log pond, sawmill deck, sawing, edging, and trimming are largely a function of the piece. The small log requires as much labor in the pond and on the deck as a large log and small logs require more time to saw in proportion to yield than large ones, because more time is consumed in handling the log on the carriage in proportion to yield; therefore, the output of a given mill sawing small logs is less than one sawing large logs. Overhead labor of all kinds is greater for small logs than for large ones, as the mill output for a given amount of labor is less.

The relative degree of hardness of the various species influences the time required to break down logs, since the more dense the wood, the slower the speed at which the log can be fed against the saw. There are other factors, however, which may modify this condition, since

TABLE II.—ONE-MAN HOURS REQUIRED TO PRODUCE 1000 BOARD FEET OF LUMBER FROM POND TO PILE\*  
(Weighted on Basis of Mill Output)

Occupation	SPECIES †												Average (16 mills) One-man hours	
	Douglas Fir (4 mills) One-man hours		Eastern Hemlock (2 mills) One-man hours		Southern Yellow Pine (4 mills) One-man hours		Mixed Hardwoods (2 mills) One-man hours		Eastern Spruce (3 mills) One-man hours		Cypress (1 mill) One-man hours			
	Number	Percent	Number	Percent	Number	Percent	Number	Percent	Number	Percent	Number	Percent		
Sawmill foreman.....	0.0674	0.90	0.1200	1.53	0.1260	1.56	0.1011	1.25	1.006	1.12	0.1533	1.36	0.0817	1.00
Log pond or yard.....	0.2481	3.33	0.3520	4.50	0.3751	4.52	0.4275	5.15	0.3432	3.83	0.5316	4.70	0.2986	3.83
Sawmill deck.....	0.0745	1.00	0.1200	1.53	0.1081	1.34	0.1921	2.30	0.3165	3.53	0.3681	3.26	0.1106	1.42
Sawing.....	0.8470	11.42	.8980	11.47	1.0048	13.17	1.1924	14.28	1.1000	12.27	1.2268	10.88	0.9795	12.55
Edging.....	0.3509	4.70	0.3649	4.66	0.5422	6.70	0.4217	5.05	0.4915	5.48	1.2268	10.88	0.4015	5.15
Trimming.....	0.3314	4.44	0.3649	4.66	0.3030	3.75	0.2449	2.95	0.4385	4.88	0.3681	3.26	0.3256	4.20
Refuse disposal.....	0.1442	1.93	0.3099	3.95	0.2977	3.70	0.1318	0.50	0.4175	4.66	0.5010	4.45	0.1928	2.35
Filing.....	0.1573	2.11	0.2593	3.31	0.1945	2.40	0.2313	2.80	0.2211	2.46	0.2454	2.17	0.1802	2.30
Power and oiling.....	0.4222	5.66	0.4961	6.35	0.5634	6.80	0.6163	7.40	0.6240	7.00	0.9073	8.04	0.4790	6.15
Repairs.....	0.4475	6.00	0.3698	4.72	0.2692	3.35	0.9453	11.35	0.9441	10.53	0.4728	4.20	0.5033	6.45
Night watch and fire pro- tection.....	0.1884	2.52	0.1724	2.20	0.1429	1.80	0.1337	1.65	0.2474	2.76	0.5623	5.00	0.1819	2.35
Clean-up and miscellane- ous.....	0.5271	7.07	0.8746	11.17	0.5142	6.36	0.5220	6.25	0.6635	7.40	0.7080	6.28	0.5636	7.10
Sorting.....	1.4954	20.06	1.0326	13.17	1.0366	12.85	0.8005	10.30	0.8809	9.83	1.2933	11.47	1.3019	16.65
Yard.....	2.1516	28.86	2.0918	26.75	2.5363	31.40	2.3177	27.33	2.1736	24.25	2.1170	24.05	2.2276	28.50
Total.....	7.4530	100.00	7.8257	100.00	8.0740	100.00	8.3474	100.00	8.9624	100.00	11.2763	100.00	7.8278	100.00

\* Based on data contained in Wages and Hours of Labor in the Lumber, Millwork and Furniture Industries, 1915. U. S. Dept. of Labor. Bureau of Labor Statistics, Bul. 225, 1918.

† The average log content in feet log scale was as follows: eastern spruce, 98; eastern hemlock, 110; mixed hardwoods, 116; southern yellow pine, 127; cypress, 235; Douglas fir, 853.





## GENERAL SCHEME OF SAWMILL LABOR ORGANIZATION

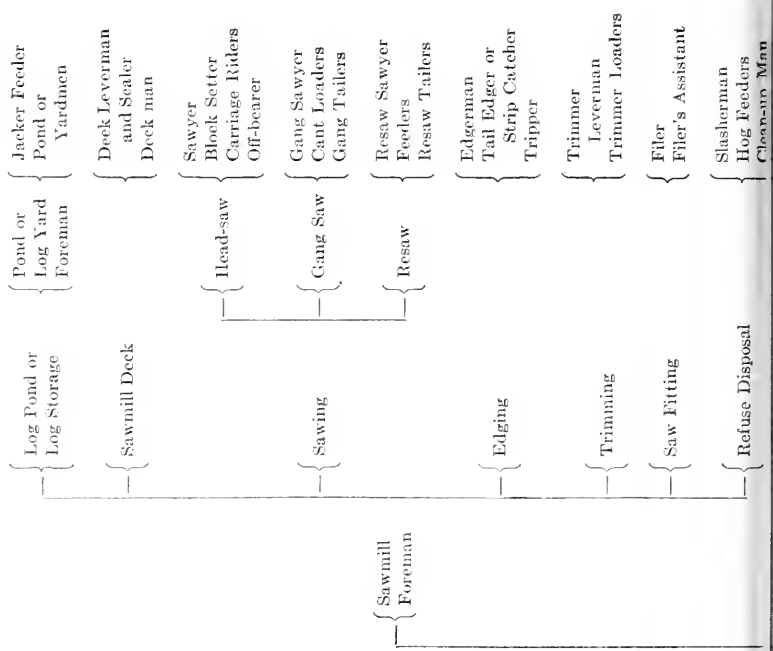

General Manager { Plant Sup't.	{ Master Mechanic Power and Repairs	{ Fireman Oiler Millwright Machinist Blacksmith Carpenter Tinsmith
	{ Protection	{ Watchman
	{ Lumber Inspector Grading	{ Graders
	{ Yard Foreman Yard Seasoning	{ Rough Assorters Truckers Stackers
	{ Dry Kiln Foreman Dry Kilns and Dry Sheds	{ Edge sorter Truck Loaders and Unloaders Truckers to Shed Shed Stackers
	{ Planing Mill Foreman Planing Mill	{ Machine Feeders Machine Tailers Tool Fitters
	{ Mill Supplies	{ Supply Clerk
	{ Shipping Clerk Shipping	{ Truckers-in Tallymen Car Loaders and Truckers

To face page 181.



a close degree of utilization or very careful sawing methods used to secure maximum quality may increase the time required to saw some of the softer coniferous woods. Thus cypress, which is a relatively soft wood, requires more one-man hours for sawing than any of the other species shown in the table. This is due to the relatively high value of the product, which makes possible more intensive sawing methods. The extent to which labor-saving machinery has been installed in a plant has a direct influence on the one-man hours required to produce lumber, since the use of such machinery displaces in whole or in part certain forms of labor.

Ten hours constitute a day's work in lumber manufacture in all regions except the West Coast and the Inland Empire where eight hours are now the standard. There has been some agitation for an 8-hour day in other forested regions but so far it has not become an accomplished fact. A reduction in the number of hours per working shift means a reduction in daily output, because the latter is dependent on the quantity of lumber produced by the head-saws. The hour-capacity of the head-saws reached its maximum, in efficient mills, under a ten-hour system, and it is not possible to increase the hour-output except by a reduction in the quality of the product. Sawmills, therefore, which have gone from a ten-hour to an eight-hour basis have had a daily reduction in output of approximately 20 per cent.

The practice of running night shifts in sawmills is not common except in regions where lumber manufacture is seasonal. It has been resorted to in the past in all regions when labor was abundant and the market conditions called for increased production. The lumber producing capacity of the sawmills of the country, however, is greater than is required in normal times and ample production usually can be secured by operating one shift. As a rule, night operation is less efficient than day operation, and with a scarcity of labor it is resorted to only by those mills whose financial status demands maximum sustained production.

#### SAWMILL OCCUPATIONS

The crew required to operate the machinery in a modern sawmill plant is fairly well standardized, but there is a variation in the number of men employed at a plant of a given rated daily capacity, due to a difference in the character and amount of labor-saving machinery and devices installed; to the character of products manufactured; and to the general efficiency of the labor.

#### **Organization.**

Exclusive of the clerical and sales departments, the work at a modern sawmill plant may be organized along the general lines shown in the organization chart.

There are minor variations from the organization scheme shown by the chart but they are so numerous that no attempt is made to include them.

#### MANNER OF EMPLOYMENT

The custom of the industry, for many years, was to secure the necessary labor through private employment agencies or from such laborers as might apply, in person, for work. The foreman in need of men hired those required in his department. This method has disadvantages which employers are now attempting to eliminate by the establishment of joint employment agencies maintained by a group of operators, or where large numbers of men are required at one plant, by the establishment of an employment or personnel department.

Many abuses crept into the management of labor agencies due to their desire to secure fees for placing men. This often led to the dispatch of unsuitable workmen to operations. Such men either proved inefficient or remained but a short time on the plea that conditions were misrepresented to them. Since the railroad fare often was advanced to such men, the rapid labor turn-over proved a heavy financial drain on the company. A few years ago an attempt on the part of certain mills to retain men in their employ until they had "worked-out" their railroad fare led to the conviction of several operators on the charge of peonage.

When the foremen hire the employees in their departments, men may be assigned to work for which they are not well fitted and since they seldom give satisfaction under such circumstances they often are discharged by the foreman as soon as convenient. Other foremen on the plant rarely will hire a laborer discharged from another department for unsatisfactory work, and consequently the man is forced to seek employment elsewhere, even though laborers may be sorely needed.

To overcome this difficulty large plants, as a rule, have a central employment office through which all employees are hired. A record of the man's qualifications is made at the time employment is sought and when any department needs an employee, the foreman applies at the employment office stating the necessary qualifications. The available man best suited for the work is assigned to the task, and when he is no longer needed in that department, he is not discharged but sent to the central office with a statement of his record. The merits of this system are that an effort is made to assign the man to the class of work for which he is best fitted. When conscientiously administered, this method greatly reduces the labor turn-over and cuts down the expense incident to hiring labor which was a large item under

the former method. It is a more just system for the employee, because under the old plan he frequently was incompetent in the performance of the task to which he was arbitrarily assigned, while often he was an expert in some other line of work.

## UNIONS

The labor employed by the lumber industry, as a whole, has never been organized, although sectional union organizations have been formed from time to time especially during the last twenty years. The Knights of Labor had a limited following in 1899 and 1900 in the southern pineries, and in 1911 a Brotherhood of Timber Workers was organized in Texas and later spread into Louisiana. Neither of these organizations functioned for long, being active only during strikes which were promoted chiefly by outside labor leaders.

Labor unions have been more active in the Inland Empire and on the Pacific Coast than in any other sections. Strikes at individual plants or in given sections have occurred at occasional intervals, largely based upon demands for a higher rate of pay, shorter hours, improved living conditions, and recognition of the union. Some of the strikes have been founded on just causes, but often the demands "in toto" have been unreasonable.

There have been many more labor disturbances in the lumber industry in the Inland Empire and the Northwest than elsewhere because the labor is more homogenous, chiefly foreign born, and more susceptible to effective organization than the mixed workers of the South.

One of the most notable of the labor organizations connected with the lumber industry is the Loyal Legion of Loggers and Lumbermen,<sup>1</sup> organized in the Northwest in 1917 and which now includes the Inland Empire. The idea of such an organization was first advanced in October, 1917, because the serious labor troubles in the sawmills and logging camps of the Northwest greatly hampered the production of airplane and ship timbers which were sorely needed in carrying out the war programme.

The Legion was organized by the Government through the Spruce Production Division of the U. S. Signal Corps in November, 1917, for the purpose of stimulating patriotism among the forest and mill workers and to increase the output of essential material. It comprised both employers and employees, an arbitration board composed of equal numbers of each settling labor disputes as they arose. The Legion

<sup>1</sup> Known as the 4L's.

recognized the 8-hour day and fixed the scale of wages and the conditions of employment.

The Legion was so successful in solving the labor problems of the industry that, in August, 1918, lumber operators voluntarily went on record as being in favor of the principles on which it had been founded, pledging themselves to continue the Legion, the 8-hour day, and collective bargaining, after the conclusion of the war. This action was taken at that time to counteract rumors which were afloat to the effect that following the war the operators would attempt to return to the old methods of dealing with labor. In January, 1919, the Legion was reorganized under private auspices and now covers the states of Washington, Oregon, Idaho, and Montana. It comprises within its ranks the best element among the employees.

There is usually a local in each plant, with a conference committee of three having a Secretary and a Chairman. A district committee for each state is composed of four employers and four employees. One of each class from each district committee is a member of the Board of Directors which is composed of twelve employers and twelve employees. Disagreements between employer and employee are arbitrated by these different committees or boards, the Board of Directors being the court of last resort. The employees thus have an equal voice in the settlement of labor disputes, and through the committee meetings, closer contact of employer and employee representatives and a better mutual understanding results. It represents the first application of collective bargaining, on a large scale, in the lumber industry.

The International Workers of the World<sup>1</sup> have been active throughout the Northwest, the Inland Empire, the Lake States and the South for many years, under the guise of various organizations. Their influence has been undermined in the first two regions mentioned by the 4L's, although occasional evidences of their strength are shown in local strikes, especially in logging camps.

In September, 1919, the International Union of Timberworkers, a radical organization, notified the operators in the Lake States that all members would cease work unless an 8-hour day with 10-hour pay was inaugurated within 30 days of May 1, 1920. The operators did not comply with the demand and early in May a strike was called at all mills, although the organization was not strong enough at some points to cause a "walk-out." Many of the larger plants were closed for a short time and others somewhat crippled, but by the middle of June, the greater number of the affected mills were running as before on a 10-hour basis. Dissatisfaction with the arbitrary demands of

<sup>1</sup> The so-called "I. W. W."



the union and with the conditions as handled by it caused a sufficient defection in the ranks of the strikers to enable the operators to again begin operations on their own terms.

With the exception of the Loyal Legion of Loggers and Lumbermen, the efforts to unionize the lumber industry have not met with great success.

#### ACCIDENT PREVENTION

A marked advance has been made in accident prevention at sawmill plants during recent years. Some of the accidents incident to employment around sawmill plants may be prevented by suitable safety devices but an analysis of over one thousand accidents in the southern pine region shows that 80 per cent were due to human agencies, such as carelessness, thoughtlessness, ignorance, and inattention which safety devices would not have prevented.<sup>1</sup> The records of the Southern Pine Association showed the following causes of accidents by per cents; hand labor, 40.6; fall of machinery, 14; use of machinery, 12.7; slipping on nails, and falls 12.4; railroad operation, 3.8; miscellaneous, 16.5.

The location of these accidents according to per cent were as follows: logging operations, 36.8; plant, including yards, docks, and kilns, 21.2; carpenters, machinists, and other mechanics, 13.6; sawmill, 16.7; planing mill, 9.7; miscellaneous, 2.

The efforts made to reduce accidents, in the main, have consisted in the installation of suitable safeguards around dangerous machinery; close supervision by foreman; the placing of warning signs at dangerous points; and the general education of the employee along "safety-first" lines. The educational feature comprises bulletins, talks, and moving picture exhibitions. These depict the results of carelessness. The educational campaign has proved to be of the highest value because it has brought home forcibly to the individual workman the dangers to which his carelessness may subject him.<sup>2</sup>

<sup>1</sup> See American Lumberman, Nov. 8, 1919, page 57.

<sup>2</sup> For a detailed discussion of woodworking safeguards and their use in the lumber industry, see *Woodworking Safeguards*, by David Van Shaack, Aetna Life Insurance Co., Hartford, Conn., 1911.

WORKMEN'S COMPENSATION ACTS<sup>1</sup>

Employees were formerly compensated for injuries received during the course of their employment through provisions laid down by Employer's Liability Laws, which held the employer liable for accidents that occurred through his failure to observe the law. The method prescribed for determining the measure of damages due to the employee, in the course of time, proved unsatisfactory, both to master and servant, because recourse was usually had to law to determine the validity of the claim. This often required many months and even though the injured workman finally was granted an award, a large part of it was absorbed by the lawyer's fee. The delay in payment also worked a hardship upon the laborer because he was without financial aid at the time it was most needed, namely, during the period of his incapacity.

In many states the liability laws have been supplanted by some form of a workmen's compensation act, which provides, without recourse to the courts, for the payment of a specified sum for given injuries to the injured or his or her dependents, provided the injury was not self-inflicted.

Under the liability laws, the chief defense set up by the employer was what was known as the "common law defense," namely "contributory negligence," "assumption of risk," and the "fellow servant" rule. The workmen's compensation acts, except under certain specified conditions, deprive the employer of the right to set up any of these defenses, when the case of an injured workman is under consideration.

The operation of the law varies in different states. In some, the law applies to all hazardous occupations; in others it is optional with the employer under certain conditions. The burden of the award falls entirely upon the employer in all states, except three.<sup>2</sup> In the latter cases the employees contribute a small per cent of their monthly salary to a joint employer-employee fund from which awards are paid. The employee's contribution is usually not in excess of 10 per cent of his monthly wage. While all so-called compensation laws provide for fixed awards in case of industrial accident, some go further and provide for insurance systems under state or private supervision.

In the case of state insurance, the employer pays into the state insurance fund a certain per cent of his monthly payroll. Each industry

<sup>1</sup> See Workmen's Compensation Laws of the United States and Foreign Countries, U. S. Department of Labor Bureau of Labor Statistics. Bul. No. 126, Washington, Dec. 23, 1919.

Copies of the laws of individual states may be secured on application to the Secretary of State of the state concerned.

<sup>2</sup> Maryland, Oregon, and West Virginia.

is classified on the basis of its relative hazard and the premiums rated accordingly. Likewise all awards from a given industry are paid out of the funds contributed by that industry alone. Thus an industry with a low hazard is not called upon to share in the awards made for injuries in an industry having a greater relative hazard.

State insurance is not operated for gain, hence the premiums are designed to meet only the actual costs of administering the law. Provisions are usually made for altering the premium rate to meet the demands on the fund.

Claims for compensation are passed upon by the Board and awards paid from the accumulated funds.

The establishment of state insurance funds has met with opposition in this country, on the plea that it is inadequate and unjust. However, it appears to have given satisfaction in those states in which it has been adopted. To date, it is in vogue in a few states only.

In the case of those states which do not operate a state insurance system, the claims may be passed upon either by the courts or by a State Board appointed for that purpose. The employer then pays the award directly. He must give satisfactory evidence of his solvency, or must give bond for any sums for which he may become liable, or must insure his liability with some approved casualty company.

The Oregon Industrial Accident Commission in comparing the results of the two systems of administering a compensation law, points out that under the workings of the Oregon, Washington, and Nevada state insurance organizations, the injured workmen received 90.8 per cent of the premiums paid, while in those states where insurance is carried by private companies, the injured or their dependents received only 46.1 per cent of the premiums paid.

## CHAPTER IX

### SAWING, EDGING, AND TRIMMING

THREE main operations are involved in converting a log into lumber or into timbers, namely, sawing, edging, and trimming.

The first process through which the log passes is sawing, which breaks the log down into units which can be handled on some auxiliary machine in the mill. When very large logs are manufactured into lumber, special "breaking down" saws are required which convert the logs into cants which can be handled on the head-saws. The latter may convert the logs into the final thickness desired. In some mills, however, the product of the head-saw is ripped into smaller pieces by a resaw, a gang edger, or a sash-gang saw. This practice varies in different mills even in the same region. When maximum capacity is sought, the daily cut can be increased by sawing thick stock on the head-saws and re-working it on other machines. The reason for this is that the output of the mill is directly dependent upon the amount of timber which passes the head-saw, and logs can be broken down more rapidly if thick stock only is cut.

The purpose of edging lumber is to square-edge the product, to rip material into narrower widths to raise the grade, and also to reduce cants to boards. The latter is practiced chiefly in the Northwest.

Trimming lumber consists in cutting the ends of the boards square; in cutting long boards into two or more pieces of standard length; and in cutting boards into two or more pieces to remove defects and thereby raising the grade.

The three operations, sawing, edging, and trimming, are the most important processes in the mill, because they determine not only the amount of lumber which is secured from a given quantity of logs, but also the quality of the product. They, therefore, influence the value of the output to a greater extent than any other process incident to its manufacture. The success or failure of a given plant may depend on the ability of the men in charge of these operations and they should be thoroughly familiar with lumber inspection and lumber values in order to secure the highest possible values from the raw material.

## SAWING

The overhead expense of a sawmill, per thousand board feet, is in proportion to its output, hence it is desirable to turn out as large a volume of product as is possible. Care must be taken, however, that quality is not sacrificed for quantity, since maximum output secured at the expense of quality often means a financial loss.

The character of the product cut on a head-saw is largely dependent on the class of timber handled and upon the class of trade to which the mill sells its output. When "board mills" are operating in small- and medium-sized timber the head-saw cuts a large amount of 1-inch and 2-inch stock and possibly some timbers. Auxiliary ripping machines are used where increased output is desired, planks or cants or both being cut on the head-saw and later re-worked on these machines. The auxiliary machinery may be resaws, a sash-gang mill, or a gang edger, by means of which cants are reduced to stock sizes.

An advantage of cutting stock sizes on the head-saw is that the sawyer by turning the log on the carriage can secure the maximum amount of clear stock while in an auxiliary ripping machine this can not be done, because the planks or cants must be cut "through and through."

Logs may be sawed into two general classes of material, namely plain-sawed and quarter-sawed. The first class of material is that which is cut in a plane tangential to the rings of growth while the latter is cut in a plane more or less parallel to the radius. Plain-sawed lumber comprises the greater part of the cut of any mill while quarter-sawed stock is manufactured for special purposes only.

Coniferous woods are rarely quarter-sawed on the head-saw, the necessary quantity of this class of material being picked out of the regular mill run or secured by ripping quarter-sawed stock from wide boards. In some mills which specialize on flooring, cants may be cut which will yield a high per cent of quartered stock. These are reduced to flooring strips in a sash-gang mill. High-grade hardwood logs are often quarter-sawed on the head-saw to secure the maximum amount of material.

Sawing lumber involves many problems other than the mere mechanical operation of the machinery, since the method of sawing is one of the most important factors in the profitable manufacture of lumber. Every log presents a special problem because there may be a wide range in size and rarely do any two logs have the same defects. Further, there is a great variety in the size, shape, and quality of the product demanded so that special care must be exercised to cut each log into the most desirable product. Hardwoods usually are manu-

factured into dimensions unlike those required in softwoods and they are graded on an entirely different system, hence the problems involved are dissimilar. It often is the case that a sawyer expert on softwoods may be an unsatisfactory man on hardwoods.

Accurate sawing demands first of all nicely adjusted machinery, because it is impossible to produce a uniform, well manufactured product when the carriage track is not level and in alignment with the saws; when the carriage and its working parts are not in proper working order; when the head-saw is not in perfect adjustment; and when the saws are not well fitted.

It is impossible to lay down any specific rules for sawing since conditions vary with nearly every log, but sawyers are able to classify logs, allowing for differences in species, under a few heads and to formulate general rules for handling them. It is true that there is a difference in methods followed by different sawyers in handling certain kinds of defects, but in general the procedure is similar.<sup>1</sup>

Two methods are used to "break-down" the log, namely "sawing alive" or "through and through" in which each cut is made in the same plane; and "sawing-around" in which the log is turned and cuts made in two or more planes. The first method is the more wasteful for logs which have much taper because in edging the boards the maximum width obtainable is that of the smaller end, the remaining edging strips being useless for lumber. With the "sawing-around" method short boards may be cut from the larger end of the log and the edging waste reduced. Another reason why large logs are "sawed-around" is that it is possible to secure more high-grade lumber both from sound and defective logs. The advantage gained by "sawing-around" is greater when the log has interior defects such as rot or cavities since a certain per cent of the output can be secured from the outside of the log which will be reasonably free from defects, and the interior defects can be confined to the minimum number of pieces. Since it requires more time to saw logs by the "sawing-around" method, the advantage gained in quality may be more than offset by the greater time required. This usually is true with small logs, and consequently they are "sawed alive."

There is a marked difference of opinion, especially among hardwood manufacturers as to whether logs should be placed on the carriage butt-end or top-end first. The large "board mill" operators favor placing the small end of the log first, claiming that the saw feeds better when it enters the small end of the log first and also because it facilitates edging since the narrow end of the board comes first to

<sup>1</sup> See foot notes on pages 201 to 203 for sawing instructions issued by an Idaho mill, and "How a Western White Pine Log is Cut."

the edger saw and the edger man can gauge the width to better advantage. This is especially important in hardwoods where it is desirable to secure the maximum square-edged width.

On the other hand, small mill operators usually place the log butt first, since in the case of tapering logs it is easier to wedge the small end of the log from the rear knee than from the forward knees. Those who advocate sawing the butt-end first claim that the saw is less liable to pinch; that the slabs can be handled more easily over the rollers; and that the sawyer can see best from the butt-end the amount of good stock he is likely to get from the log before striking heart defects.

Most operators are agreed as to the advisability of sawing long timbers butt first, because the steam nigger can turn the logs better, the sawyer can see the butt defects, lighter slabs are cut, and time is saved in running the carriage. The nigger has some difficulty in turning long logs from the small end because the bulk of the weight is on the far end. If the small end is next to the sawyer it is more difficult to gauge the distance which the knees should be set forward to cut the first slab. In order to avoid making a run of the carriage without cutting a slab face of sufficient width, the tendency is to set the knees well forward, the result being that a slab thicker than is necessary is removed. Time is lost in cutting slabs when the small end is placed first, since the carriage must travel the full distance for each slab cut. On the other hand, when the butt-end is placed forward the first runs of the carriage are short, since the carriage is giggered back as soon as the saw leaves the cut. It has been estimated by one "timber" mill<sup>1</sup> operator that the output may be increased 5 per cent by cutting timbers butt-end first, due both to the greater overrun which is secured by light slabbing and to the reduction in the time required to saw a given log.

Logs with excessive taper or swelled-butts should be sawed parallel to the bark, especially in hardwoods, since this method gives a higher per cent of the best grades of lumber in long lengths and also produces straight-grained material. When tapering logs are sawed parallel to the heart the butt cuts are short, and the full-length cuts soon run into butt defects which often necessitate trimming. The center, in hardwoods especially, is the least valuable portion of the log, therefore, it is desirable to secure the maximum lengths and widths from the outer portion, which can be done only by sawing parallel to the bark.

The thickness of the slabs which are removed from a log is governed largely by the width of the narrowest merchantable board; by the character of by-products, if any, which are manufactured from slab wood; by the facilities available for the recovery of merchantable

<sup>1</sup> See Lumber Trade Journal, New Orleans, La., April 15, 1909, page 17.

lumber from slabs; and by the character of the log exterior. Heavier slabbing is justified where slabs are used for lath or shingle manufacture or where there are resawing facilities for re-working them, than when they are used only for fuel. Heavy slabbing is also practiced where the log exterior is rough or uneven, or where sapwood is a serious defect in the product being cut.

The output of a mill can be materially increased by slabbing small logs on one side only, and sending the slab and cant to a horizontal resaw to be worked into lumber.

The loss from heavy slabbing increases with a decrease in diameter and hence slabbing should be light on straight, sound, logs, except as noted above.

### Plain-sawing.

A common method of handling a hardwood log that has a very defective heart and a clear surface is to saw around the log parallel to the bark until all clear or full-width boards have been removed. The remaining cant is then split through the heart; each flitch is then turned down and sawed to the center; then turned with the center against the knees and sawed until finished. This leaves the poorest part of the log, the center, as a "dog board." When the log has a defect on one side, slabs and boards are taken from the other three sides of the log, as above, and the remaining cant then turned with the defect uppermost and "sawed alive."

A suggested method<sup>1</sup> for sound, tapering logs which will keep the sap and heart divided and produce straight-grained lumber is as follows:

1. Slab the log parallel to the bark line and continue cutting so long as the best grades are secured.
2. Turn log with slabbed face against the knees and saw parallel to the bark line, as before.
3. Turn cant board-face down and again slab and cut boards parallel to bark line until the product is of common grades.
4. Turn cant 180° and saw as in 3.
5. Turn remaining cant 90° and saw parallel to the outer face of the cant until the pith is reached.
6. Bring knees into alignment and square up face of cant. This will give a number of short boards tapering in thickness which must be trimmed and edged. When these have been removed the cuts, including the "dog board," will be full length and thickness.

<sup>1</sup> See American Lumberman, Dec. 21, 1907, page 37.



The boards tapering in width are not edged since hardwood grading rules provide for measuring the width of tapered boards one-third of the length from the narrow end. Softwood grading rules do not have provision for tapering boards, hence for softwoods the second system has no special merit which the first named method does not possess.

The method of cutting parallel to the bark should always be used where full strength in material is desired, because sawing parallel to the heart produces cross-grained stock which has a low relative strength.

Logs with crook or sweep should never be sawed into stock requiring strength because only weak pieces can be secured from the cross-grained stock. In hardwood logs having sweep, the sawyer often may add to the appearance of the boards by sawing them so as to bring out figures other than those produced by medullary rays; e.g., when a log is slabbed on the crooked side a desirable figure often can be secured, due to the severance of the growth rings at an angle.

There are several methods of handling crooked logs on the carriage, namely, turning the crook down, up, toward the log deck or the knees, or placing the crook so that the ends of the log point upward and away from the knees at an angle of about 45°. Small logs often are "sawed alive," while large ones are "sawed-around." The first method, pointing the ends of the log downward, is not often used because the ends of the log may drag on the deck or strike the lower saw guide and displace it. The last method, when the log is "sawed alive" is regarded as the one by which the greatest amount of wide lumber can be secured from a log having a simple sweep.

The loss in sawing logs with a given sweep increases with a decrease in diameter, hence small logs with a pronounced sweep usually give a very low yield. They also are difficult to handle and the sawing crew uses the quickest method possible to get rid of them, without regard to the volume secured.

Timbers of different degrees of hardness present different sawing problems and when possible, they should be segregated into a few groups, each one being sawed separately.

There are various methods for handling the average run of logs, when they are sawed-around. One method<sup>1</sup> advocated for sawing hardwood logs to secure the maximum amount of high-grade material is shown in Fig. 124. The cant (*e*) shown in the figure if practicable should be cut 8¼ inches thick, which will permit any board of the requisite quality to go into the "firsts and seconds" grade.

The right and wrong method advocated for sawing logs with one large knot is shown in Fig. 125 *a* and *b*, and with two large knots in

<sup>1</sup> See American Lumberman, Dec. 21, 1907, page 37.

Fig. 125 *c* and *d*.<sup>1</sup> When sawed as in *a* every board cut up to the first turn will have a knot in it, while if cut as shown in *b*, the knot will come on the edge of the boards, and can be ripped off if necessary. In *c* knots will appear in the center of all boards on both turns of the log, while if cut as in *d* the knots will be on the edges of the boards.

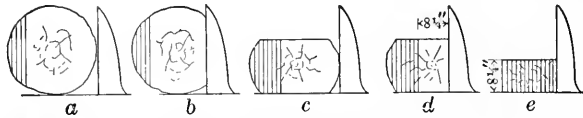

FIG. 124.—A Method advocated for sawing Hardwood Logs to Secure the Maximum Amount of High-grade Stock.

In Fig. 126 *a* and *b*, are shown the methods recommended for cutting northern hardwoods, which, as a rule, have defective hearts. Mills equipped with a sash-gang saw, often cut on a sash-gang the cant shown in *a* since the lumber will be low grade and nothing is gained by working it on a head-saw.<sup>2</sup>

In sawing medium-sized logs such as southern yellow pine, the common practice in "board mills" is to cut the clear stock from the

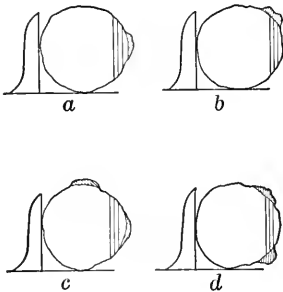

FIG. 125.

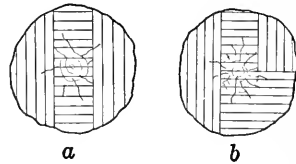

FIG. 126.

FIG. 125.—Methods for sawing Knotty Logs. *a*. Incorrect Method of sawing a Log having One Large Knot. *b*. Correct Method of sawing the Log shown in *a*. *c*. Incorrect Method of sawing a Log having Two Large Knots. *d*. Correct Method of sawing the Log shown in *c*.

FIG. 126.—A Method used in sawing Northern Hardwoods which have Defective Centers. The Cant shown in *a* often is resawed on a Sash-gang Mill instead of on the Head-saw.

outside of the log, reducing the latter to a cant 12 inches or less in thickness and then sawing the cant "through and through" into 1- or 2-inch stock. There are many variations in sawing methods used

<sup>1</sup> See American Lumberman, July 12, 1913, page 49.

<sup>2</sup> See Hardwood Record, Aug. 25, 1905, page 14.

to produce flooring flitches, cants for the gang-saw, and timbers, but the usual practice is that described above.

### Quarter-sawing.

There are many methods of sawing logs to secure quartered-sawed or edge-grained stock. Some yield a greater per cent of lumber than others, although those which produce the greatest amount of true quartered material often yield the least total board foot contents, since true quartering is a wasteful process often causing the loss of 20 per cent or more of the log content as compared to the yield from plain-sawing.

The choice of the method of quartering usually is based upon the purpose for which the product is to be used. The chief reasons for quartering lumber are to show the figure in the wood; to secure a hard wearing surface which will not sliver; and to secure material which will hold its shape and be subject to minimum shrinkage and warping.

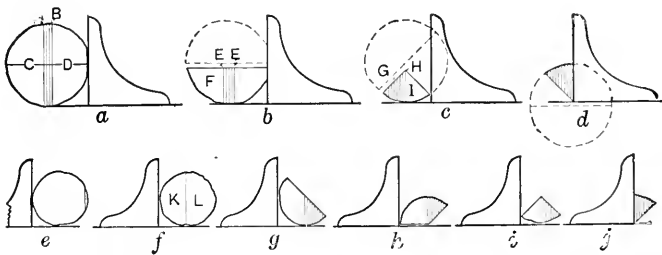

FIG. 127.—Two Methods of quarter-sawing Hardwood Logs. *a, b, c, and d.* Logs 20 Inches or more in Diameter. *e to j,* inc. For Logs from 16 to 19 Inches in Diameter.

Hardwoods, especially oak, are quartered for the first reason since the exposure of the medullary rays of the white-oak group produces a figure greatly sought for cabinet purposes. Radial cuts have the best figure, but this method of sawing is not followed because true quarter-sawed boards are wedge-shaped in cross-section, and the loss of raw material is too great.

The two methods shown in Fig. 127 are those advocated some years ago by the Hardwood Manufacturers' Association of the United States, and are designed for the most economical sawing practice. The illustrations *a* to *d* inclusive are for logs 20 inches and over in diameter (this is sometimes called the 8-point method); and *e* to *j* inclusive for logs under 20 inches in diameter. It is seldom profitable to quarter-saw logs under 16 inches because of the excessive waste.

The procedure for quarter-sawing logs over 20 inches is as follows:

1. Slab the log on one side and turn that side against the knees. Then make the cuts from *A* to *B*, throwing *C* upon the log deck. The number of cuts will vary with the size of the log. Cut as many boards as show a satisfactory quartered figure.
2. Turn the slabbed face down upon the head-block and cut from *E* to *E*, throwing *F* upon the log deck. The number of cuts will vary with the size of the cant. Cut as many boards as show a satisfactory quartered figure.
3. Turn the slabbed face at an angle of  $45^\circ$  to the head-block and cut to *H* or until the sector *I* has a sharp point.
4. Turn *I* over as shown in *d* and finish. The sector *F* is sawed as in *C* and *D*.

The rule for quarter-sawing logs less than 20 inches is as follows:

1. Slab the log lightly.
2. Turn the slabbed face down upon the head-blocks and saw one board beyond the pith. Throw *L* upon the log deck.
3. Turn *K* to the position shown in *g* and saw to the heart.
4. Turn remaining part of *K* to position shown in *h* and saw to the heart.
5. Turn to position shown in *i* and saw to the heart.
6. Turn last one-eighth sector to position shown in *j* and finish. The section *L* is cut in the same manner as *K*.

Fig. 128*a* illustrates the so-called 6-point method of quartering which is used at some large mills. It is not as favorably regarded as

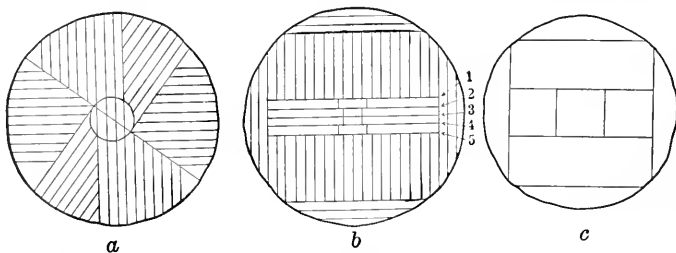

FIG. 128.—Methods for cutting Quarter-sawed Stock from Large Logs. *a*. The 6-point Method. *b* and *c*. Methods for cutting Cants from Logs so as to secure a high Per Cent of Quartered Stock.

the 8-point method, because the narrower boards have an inferior figure and some of them will not pass inspection as quartered stock. A central core about 6 inches in diameter will be plain-sawed and this

must be removed by edging. The loss is not great, however, because the heart wood near the pith usually has defects which if left on the board would lower the quality. Both the 8-point and the 6-point methods can be used only in mills equipped with band head-saws and with quartering dogs on the carriage.

A modification of the 8-point method was devised some years ago to reduce the cost of quarter-sawing. This follows the 8-point method up to *c*, Fig. 127. Instead of sawing the sectors as shown in *c* and *d*, they are sawed radially into two equal parts. These parts are then worked up on a horizontal resaw, equipped with a return roll system. Boards are cut alternately from each face of a sector. Since several sectors can be run through the resaw at one time, there is a reduction in sawing cost as compared to the practice of making all cuts on the head-saw.

Where only mere resistance to wear is desired, such as in softwood flooring, sawing need not be so exact as where figure is sought. Grading rules provide that where the annual rings do not tip more than  $45^\circ$  from the vertical at any point along the piece, the latter may be considered quarter-sawed.

Few mills, other than those which make flooring a specialty, attempt to produce large quantities of quartered flooring strips, but secure the necessary supply from wide boards, which when ripped will yield one or more edge-grained strips. When a large quantity is desired, cants which will produce a high per cent of quartered stock are cut from large logs and resawed on a sash-gang. Although there are various schemes for cutting logs to secure suitable cants for quarter-sawing, the general plan is shown in Fig. 128 *b* and *c*. The procedure in the case of *b* is to slab on four sides to an 8-inch heart-face and then cut lines 1 to 5 inclusive. The cants, usually 4 inches in thickness, are then run through a sash-gang mill and ripped into 1-inch stock. All but a few of the outer boards will pass as quarter-sawed stock.

In *c* the log is slabbed on four sides and reduced to a size which will saw into three 4-inch cants. The two outer cants are then put through a sash-gang mill as in *b*. The central cant is cut into three pieces, the two outer ones being cut into quartered stock and the central one either into flat-grained stock or left as a square. When freedom from warping is the quality desired it is customary to use quartered-sawed material, but strict adherence to true quartering is not observed because it is not necessary to do so in order to obtain material with the quartered effect, and, further, wider boards can be secured by not sawing in a true radial direction.

In Fig. 129 a method of quarter-sawing red gum is shown where the quartered effect, rather than the figure, is sought. Since heartwood only

is desired, the log is first slabbed on four sides and the sap boards removed. The cant is then split into two pieces which are "sawed alive" as shown in *b*. The flat-grained heart from the edges of those boards which come from the vicinity of the pith is removed by ripping it off with an edger. The outside boards on *b* will be plain-sawed, but the remainder will meet the quartered requirements.

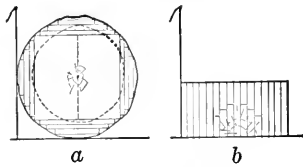

FIG. 129. — A Method of quarter-sawing Red Gum when the Quartered Effect rather than Figure is desired. *a*. Method of squaring the Log. *b*. Method of sawing the Cant after it has been cut through the Center. All but the outside Boards and Portions of those near the Pith will be quarter-sawed.

A method of quarter-sawing, known as "center-sawing," is used in New England in the manufacture of spruce clapboards and it is also used to some extent in other regions in sawing spoke blanks. The logs are sawed from the bark to the pith on a true radius, the product being wedge-shaped boards or sectors which in clapboards are  $\frac{5}{8}$  inch thick on the periphery of the log. They are then ripped on the thin edge to a width of  $4\frac{1}{2}$  or 6 inches. Sectors cut for spoke stock are of sufficient width to permit the piece to be resawed both tangentially and radially, each sector furnishing several

spoke blanks. In some cases, the log is merely quartered and the blanks are cut from each quarter in the form of boards, ripped alternately from the radial faces.

### Division of Time in Sawing.

In the operation of sawing, approximately two-thirds of the time of the sawyer is consumed in operating the log-stop and loader, the steam nigger, and in gigging back the carriage. The actual sawing time varies from 25 per cent to 34 per cent of the total.<sup>1</sup>

Mixed hardwood logs from 10 to 20 feet in length may be cut at the rate of approximately eight lines per minute, southern yellow pine at the rate of nine lines per minute, and cypress and large timber about six lines per minute. These rates will vary greatly under the many conditions which may arise and hence the above figures represent general averages only.<sup>2</sup>

<sup>1</sup> The usual division of time is as follows: operating the steam nigger 45 per cent; feeding the saw, 33 per cent; carriage running idle, 16 per cent; operating the log-stop and loader, 6 per cent. See *Wood Worker*, Oct., 1912, page 36; and Sept., 1912, page 36.

<sup>2</sup> A table giving the average time required to saw western pine logs of given diameters and also the time required to saw 1000 board feet of lumber from them is given in the Appendix, page 511

### Sawyers' Signals.

There must be very close cooperation between the sawyer, the block setter, and the carriage riders in handling a log on the carriage. The sawyer, therefore, must have some means of communicating to the carriage men what he wishes done with the log. Owing to the noise present in a sawmill, it is impossible to give orders verbally and the code of signals shown in Fig. 130 has been devised. This admirably meets the need and is in universal use in all parts of the country.

This code does not permit of fractional combinations in one movement, and in such cases two or more signals are given. Following a signal for a whole number, the thumb erect signifies  $\frac{1}{2}$ , the little finger erect,  $\frac{1}{4}$ , and the index finger pointing downward,  $\frac{1}{8}$ . A combination signal for  $3\frac{1}{4}$  is the signal for 3, followed by the little finger erect; that for  $3\frac{1}{2}$  is the signal for three followed by the thumb erect; that for  $7\frac{3}{8}$  is the signal for 7, followed by that for 3, and then that for  $\frac{1}{8}$ , the index finger turned downward. In sawing lumber of special thickness, the sawyer and setter often have a local code adapted to meet their special needs. Instructions to turn the log are given by raising the open hand with the palm out, then dropping the hand to the side. The order to set a log for cutting a slab is given by raising the closed fist and holding it in that position until the log has been properly placed, when the hand is dropped to the side.

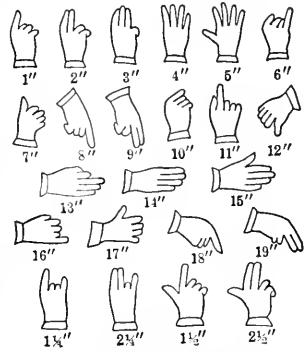

FIG. 130. — Signals used by Sawyers to indicate to the Block Setter on the Sawmill Carriage the Depth of Cut, in Inches, desired on a Log.

### EDGING

The greater part of the lumber cut of the country is placed on the market square-edged, one exception to this being box-board stock manufactured from second-growth white pine in New England, which often is sold round-edged. General construction woods are, as a rule, made in even-inch widths and hardwoods in both even- and odd-inch widths, as wide a board as possible being secured. The mere process of square-edging boards is largely mechanical, because the edgerman has only to space his saws at the proper distance to suit the narrowest part of the board, and to feed it properly into the machine to secure the result desired.

The edgerman's work is not so simple, however, since his duty is not only to square-edge boards but also to rip wide boards into narrower ones in order to raise either the grade of a portion of the board or to secure special stock such as narrow edge-grained flooring strips. This work, if properly done, requires an expert knowledge of grades and values else the edger operator may work the material so that either its quantity or value or both may be reduced.

Edging hardwoods, especially, requires a detailed knowledge of grades, since the latter are based largely upon the per cent of clear cuttings which can be secured, and every piece should be made to carry all of the defects allowable. Whether it pays to rip a board into two or more pieces, one or more of which will be of higher grade, depends upon the relative value of the board before and after ripping.

The practice exists in some mills, especially in the Northwest, of cutting cants on the head-saw and splitting them into narrower pieces on the edger. In this capacity the edger functions as a resaw, the operation requiring no special qualifications other than ability to feed the cant properly to the saws. Ripping cants on the edger is not considered a good practice by some operators because the saws cut a  $\frac{1}{4}$  or a  $\frac{5}{16}$  inch kerf which is wasteful if the product is high grade. However, when output is the desired object this method often is followed because the cut of the mill can be materially increased.

Edging lumber on the head-saw, a practice in vogue among small mills, does not permit one to secure the highest quality from individual boards, unless an undue amount of time is spent in the work. The result, therefore, is that the mill is run for output, which leads to waste and to production of a high per cent of the lower grades. The rule should be to so cut the lumber on the head-saw that the minimum of edging is required.

#### TRIMMING

The chief objects of trimming lumber are to cut the ends of a board so that they will be square; to cut a board into two or more pieces to raise the grade of a portion of it; or to cut a long board into two or more standard lengths. The first and last mentioned operations are mechanical and do not require any special knowledge on the part of the operator other than the lengths desired. The second operation, however, requires a knowledge of grades and values. The trimmer lever-man must decide whether the elimination of a portion of a board will increase the value of the remaining portion sufficiently to justify the loss in volume, and in so doing he must bear in mind both the grade and the shorter length or lengths secured since the length may influence the market value.



## NOTE TO CHAPTER IX

Page 190

## "INSTRUCTIONS TO SAWYERS

"The following instructions are given to help you in the cutting of logs. You will appreciate that it is impossible to cover everything in detail, and much must be left to the judgment of the sawyers. Sawyers must constantly bear that in mind in sawing a log.

"Naturally, we wish to produce all the lumber possible, but we do not want quantity if we must sacrifice quality. Quality must always be the goal which every sawyer must strive for. Quantity is secondary. The sawyer who can get both quality and quantity is the ideal sawyer.

"Logs must be sawn in such a manner as to segregate the various grades. In other words: Get your selects, shop and common separated in the lumber produced.

"If the log is improperly sawed, you will find the different grades in each piece. Take for instance: A common board will have select on one edge while the balance is common. This must be ripped on the edger, which produces narrow stock of little value and this, if less than 4-inch, always must go with the common and be sold at a common price, thus reducing the value of the stock you produce.

## "PROPER METHOD OF CUTTING

"In most cases, after cutting the first face, the log should be turned with the face to the blocks and not turned down. This method will increase your overrun.

"In cutting a select log, the selects lie on the outside of the log, and to get these all off the log should be turned and the sawyer should go entirely around the log, being careful not to turn the log against blocks until you have gotten into the common grades.

"Shop logs should be cut in practically the same manner. In other words: If the log contains both selects and shop, take off all the selects and shop, regardless of size of cant; then size your cant to even inches, cutting whatever size you have instructions for.

"In cutting thick shop and selects, after slabbing, take off at least one board to give you a larger face; then saw whatever size you have special instructions for. Before cutting 8/4 in the shop or selects, you should saw 1-inch until you have a 10- to 12-inch face.

"Sawyers should aim to get the log into as large a square as possible after getting off the selects, as this prevents the necessity of edging, which is always waste. This method will greatly increase your overrun.

"We shall insist that logs be slabbed so as to save every foot of merchantable lumber. To do this, it must not be thrown away in the slabs. Logs must be slabbed light. Slabs should not show a face over 4 inches wide and 6 feet long. Wood is valuable as fuel, but we are not operating a sawmill to produce wood.

## "TAPER LEVERS

"We must insist that carriage men use taper levers, especially on select and high-grade shop logs. Taper should be held until you get into common grades and the cant should be straightened before turning down. If necessary again, use taper levers after turning down. In no case allow wedge-shaped boards to go to the edger, as this is wasted.

"The free use of taper levers gives a large increase in percentage of long selects, and, by making straight-grained stock, improves the grade. Proper tapering should

give you a uniform face the entire length of the log. Do not forget that taper levers are put on a carriage for a purpose, and we expect—and shall insist—that they be used for the purpose for which they were intended.

#### “FIR AND LARCH LOGS

“In cutting fir and larch logs, the same rule of slabbing light must be observed. Cut 1-inch until you have a face of at least 6 inches wide and 10 feet long; then cut 2-inch or such stock as you have special instructions for.

“The smooth, small logs should be cut to 2×8, especially those intended for 2×4, which should be ripped on edge. Do not cut stock larger than 2×8 when it is intended to be ripped on the edge to 2×4.

“Cull logs and logs with checked, pitchy hearts should be cut into 6×6 for yard ties and foundation stock.

#### “SAWING SIZES FOR PINE LUMBER

“For all inch stock, set up  $1\frac{3}{32}$ ”.

“For all 5/4 shop and selects, set up  $1\frac{17}{32}$ ”.

“For all 6/4 shop and selects, set up  $1\frac{25}{32}$ ”.

“For all 8/4 shop and selects, set up  $2\frac{8}{32}$ ”.

“For all thick common, set up same thicknesses as shop and selects.

#### “SAWING SIZES FOR FIR AND LARCH LUMBER

“For all 1” stock, set up  $1\frac{3}{32}$ ”.

“For all 2” stock, set up  $1\frac{7}{8}$ ”.

“For all 3” plank, set up  $2\frac{7}{8}$ ”.

“Timbers 4×4 to 8×8 should be sawed  $\frac{1}{4}$ ” scant.

“Above instructions are general and we shall expect and insist that they be followed as closely as possible. From time to time special instructions will be given in writing as to kind and sizes of lumber we wish cut, so as to keep our stock well balanced and to meet the demand of the trade. Such instructions must be followed, cutting in accordance with the general instructions.

“All instructions will be in writing from the general office, and each sawyer will be furnished with a copy of same, except that occasionally there may be put on the blackboard some special items that it is necessary to cut to fill some particular order—and such items should take precedence over everything else.”

#### “HOW A WESTERN WHITE PINE LOG IS CUT<sup>1</sup>

“One of the fundamental principles in manufacturing lumber is that the grades in the log should be segregated so that they will be separate in each unit of the finished product. The selects lie near the surface of the log and are the most valuable part, therefore, every effort should be made to obtain the maximum amount of these. Light slabbing is essential if we are to conserve the selects. In a log of this type the slab does not represent the average grade of the log but comes from the highest-priced product. Most manufacturers slab entirely too heavily. To obtain the maximum amount of selects the log should be turned and cut on all sides.<sup>2</sup> Most sawyers, as long as the cut shows a select face, continue cutting on this face until the grade changes, which is a fairly safe rule to follow; but the average log should be turned and cut from each face and the log reduced to the largest square possible which will rip

<sup>1</sup> By R. E. Irwin, *The Timberman*, March, 1921, p. 41.

<sup>2</sup> See Fig. 131.

to standard sizes without waste. This method reduces the edging waste to the minimum, and it should be borne in mind that edgings, like slabs, come from the best part of the log. The tendency of most sawyers is to cut too deep into the log before turning, thus causing a loss in grade as the different grades are combined in each piece and often cannot be separated into merchantable sizes and the high-grade stock is sacrificed.

“When the next grade is shop or factory lumber. In the diagram <sup>1</sup> the thickness shown is 6/4, as the demand for this thickness is much greater than for any other. In both shop and selects the thickness cut is determined largely by market and stock conditions and may be varied to comply with these demands. Unless the log is the coarse, sparsely knotted, ideal shop type, no attempt should be made to cut 8/4. Shop is graded from its poorest face and the change in grade from the best to the poorest face is too great in this thickness, except in logs of the above type. For this reason 8/4 shop should command a much higher price than 5/4 or 6/4.

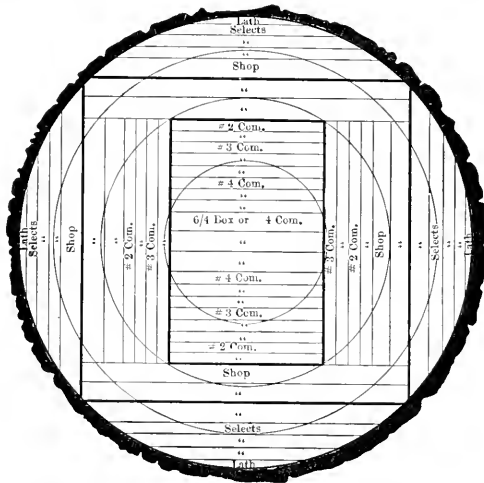

FIG. 131.—A Method recommended for sawing Western White Pine.

“The common grades come next and this class of logs yields little or no No. 2 common, the remaining stock being mostly No. 3, with the heart piece No. 4 or box.

“With logs of this size and type, except in extreme cases of shortage of other sizes, the cant should be 12 inches. The defects in most instances are such that it will grade a No. 3 in 12-inch, but if reduced to 8 or 10 inches, the grade will frequently fall to a No. 4 or box.

“The heart of the log may be cut into 5/4 No. 4, but where there is a market for 6/4 box it is generally best to cut this, as 5/4 containing heart defects will show a heavy percentage of degrade in drying.

“To offset any over-production of 12-inch all the smaller common logs should be canted to 8 or 10 inches if necessary to balance stocks and supply the demand for these sizes.

“It has been demonstrated by actual tests that this method of cutting the western pine timber of this section will produce the highest quality and the greatest quantity of lumber from the log.”

<sup>1</sup> See Fig. 131.

## CHAPTER X

### SEASONING LUMBER

#### REASONS FOR SEASONING

THE sawed products of the lumber industry, with the exception of large timbers, are seasoned, at least to some degree, by the manufacturer.

The chief reasons for this are:

1. The shipping weight is reduced by the elimination of the greater part of the moisture content of the wood. This is an important factor, since rail freight charges are based upon weight and not upon volume and lumber often is sold at a delivered price.

2. Most buyers desire seasoned lumber, because of the liability of the green product depreciating in quality during shipment and during the process of seasoning. They prefer to have the manufacturer carry this risk. Most buyers also do not have adequate yard facilities for the storage and seasoning of green lumber, while on the other hand the lumber manufacturer must, of necessity, provide ample storage space for such portion of his product as the market does not demand immediately. This stored lumber must be piled so that it will season properly or it will rapidly deteriorate in quality.

3. The practice of re-manufacturing lumber into finished products is possible only when seasoned lumber is available. Therefore, the lumber manufacturer who re-manufactures his rough products finds it necessary to season his output.

Green lumber contains from 30 to 100 per cent or more of its dry weight in water, the greater part of which must be eliminated before the lumber can be used for many purposes, especially for general building and for the manufacture of furniture, tools, and for other uses which require a finished product which must hold its shape when put in place.<sup>1, 2</sup>

Seasoning at the sawmill plant is accomplished either by storing the product in piles in the open or under sheds (air-seasoning) or by subjecting the lumber to artificial heat (kiln-drying).

<sup>1</sup> For a detailed discussion of "How Wood Dries" see *The Kiln Drying of Lumber*, by H. D. Tiemann. J. B. Lippincott & Co., Philadelphia, Pa.

<sup>2</sup> For the per cent shrinkage of lumber see page 503.

Softwood plants often follow both methods, the lower grades being air-dried and the better grades kiln-dried. This is especially true in the southern yellow pine region where the sapwood stains rapidly during the rainy season and also at other times when the humidity is high. Since stained sap is a serious defect in the better grades of southern yellow pine lumber, these are dried rapidly in a kiln and sap stain largely prevented. Some southern mills have adopted the practice of kiln-drying their entire output, although this is not general.

Kiln-drying is not extensively practiced in the cypress region, in the Lake States, in the spruce region of New England, and in some parts of the Northwest.

Most hardwoods are air-dried, because of the loss, due to checking and warping, which has attended attempts to dry refractory species in the ordinary type of dry kiln. The custom has grown up of air-seasoning such lumber at the sawmill plant, leaving the final drying process to the factory which uses it.

#### AIR-SEASONING

##### **Yard Location.**

In addition to the standard insurance requirements which specify that the yard must not be less than 200 feet from the nearest building, several other factors must be borne in mind in yard location. Where lumber is moved by animals, the yard should be placed so that the product as it comes from the assorting table can be taken on a slight down grade to every part of the area, and lumber from the yard taken to the planing mill, or to the loading docks, also on a down grade. This greatly facilitates the transportation of lumber and keeps down operating costs. The yard also should be on a well-drained site, preferably mineral soil, because lumber dries slowly when the surface of the ground is wet. A good circulation of air is an essential to rapid drying and the location should be where this can be secured.

Storage and seasoning yards should be laid out as compactly as possible, since long narrow yards increase the cost of handling. Where land is cheap and ample piling space is available, no attempt is made to place lumber in high piles, for it increases the cost. On the other hand, when land values are high or piling space is limited, the piles must be made high in order to store the required amount of lumber.

##### **Runways.**

A yard is provided with numerous dolly-ways or runs which afford ready access to all parts of the area. One or more main runs serve as

the chief avenues of transportation from the various plant units to the yard, while secondary runs, at right angles to them, divide the yard area into convenient blocks.<sup>1</sup> The width of the main run varies with the methods of transporting lumber and with the piling methods. As a rule, lumber is stored along the sides of the runs, until it is placed on the piles and, therefore, they must be wide enough so that the stored lumber will not interfere with the passage of loads of lumber along the center of the run. The width of main runs often is from 20 to 30 feet and that of the secondary ones from 16 to 22 feet. They may be built at the ground level or elevated on trestles, in order to maintain an even grade throughout.

Some advocate the use of ground runways for hardwood mills, because lumber in the pile between the tram floor and the ground dries slower than that above the tram level, owing to impeded air circulation. While elevated trams make it possible to store more lumber in a given space, this is not regarded as a logical argument in the case of hardwoods, because the weight of high piles of lumber causes the stickers to sink into the lower courses of boards and thus degrade them. Elevated runways are expensive to construct and maintain and, therefore, are not feasible for small plants. They are most commonly used at large softwood plants.

When the runs follow the ground level, it is customary to pave the surface with brick or some other hard material; to cover them with sawdust or cinders;<sup>2</sup> or to plank them, since the passage of wheeled vehicles over a dirt bottom, during rainy periods, soon cuts it up and renders it impassable. Lumber which is temporarily stored on the ground also becomes gritty from dirt and sand accumulations and rapidly dulls the knives of surfacing machines when the material is being re-worked in the planing mill. When light cars are used to haul the lumber to the yard, wooden or steel rails are laid on cross ties only.

When elevated structures are used for wide runs the supporting bents have three or four legs, while for the narrower ones two or three legs are used. The bent legs are made from 8- by 8-inch timbers supported on concrete bases. The caps of the bents are 6- by 8-inch stock, the floor joists 2- by 8-inch, or 2- by 10-inch dimension, and the decking 2½- or 3-inch dimension. The bents are braced both laterally and longitudinally with 2- by 6-inch dimension. A common type of trestle is shown in Fig. 132.

<sup>1</sup> See Fig. 4, page 10.

<sup>2</sup> The covering of cinders should be about 4 inches deep. Their efficiency in preventing weed growth is due chiefly to the presence of sulphur or sulphide of iron which, when combined with water, produces sulphuric acid. Ashes are not satisfactory because they contain potash, which promotes weed growth.

The timber used for the bent construction should be heart stock, because of its more durable character. The decking may be either softwood or hardwood, depending on the material available.<sup>1</sup> Hardwoods are preferred where animals are used to haul the lumber to the yard, because they last longer under the constant travel of shod animals. Some prefer to place the decking parallel to the direction of the runway, while others place it cross-wise. The latter plan is considered preferable by many because there is less danger of the decking giving way between the joists and permitting buggy wheels or an animal's leg to go through. However, the lumber buggies pull easier when the decking is laid parallel to the runway.

Lumber is piled along each side of the runway and at right angles to it. The distance between piles is from 2 to 4 feet. The distance between the ends of two piles on parallel runways is dependent

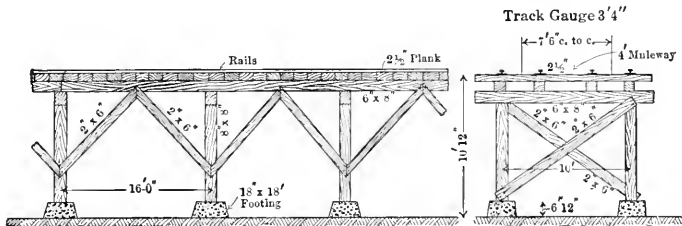

FIG. 132.—A Form of Trestle for a Runway in a Lumber Yard where Small Rail Cars and Animal-draft are used. The same Type of Trestle is adapted for a Runway on which Lumber Buggies are drawn by Animals or Tractors.

on the length of the lumber and on whether a loading track is placed between them. Where standard lengths are piled and loading tracks are not provided the distance between parallel runways varies from 40 to 50 feet, while a 75-foot spacing is needed if a loading track is put in. The latter is required only when a large amount of lumber is shipped in the rough, such as at hardwood plants. The product in this case can be loaded directly from the pile into the car, with a minimum of handling.

Cross runways are seldom less than 250 feet apart. When they cross a loading track, they must be provided with some form of lift-bridge which will permit locomotives and cars to pass.

In general, the practice is to use the same runways, continuously, for piling certain kinds of stock, so that confusion will not result when planing-mill truckers are sent to the yards for stock. At some mills the largest-sized stock is piled nearest the planing mill, and the shortest

<sup>1</sup> Hardwoods, such as tupelo, are considered very satisfactory for tram decking because the wood does not splinter, but wears off fairly smooth.

stock in the more distant parts. This enables the truckers to keep the planing-mill machines in continuous operation because the heaviest pieces require less time, per thousand board feet, for working than do the short pieces and consequently the truckers have less time between loads.

It is customary in softwoods to segregate boards of given grades and sizes. The advantages of this method are that piling is made easier when boards are of one size; it is not necessary to handle material in the pile which is not wanted for a given order; and inventory taking is simplified. The exception to this procedure may be noted in some of the lowest grades, which are sometimes, but not always, piled together in all lengths and widths. The reason for this is that the product may be sold in random widths and lengths and consequently when the pile is taken down, there are no rejects to re-pile. Hardwoods, on the other hand, are commonly sold in random widths and lengths and, therefore, some segregate them by thicknesses and grades only. However, the best piling practice for hardwoods is to segregate given lengths.

### **Pile Foundations.**

Substantial pile foundations are essential to the successful drying of lumber. They should be solid so that the weight of the pile will not cause the foundation to settle; they should have enough pitch toward the rear so that water cannot collect on the boards and cause slow drying or decay; and they should be high enough above the ground surface to permit the ready circulation of air underneath the pile.

Foundations made of plank or timbers are in most common use because of their relative cheapness but they are not so satisfactory as those made from concrete, because of their liability to decay, which not only results in an insecure base, but also provides a source from which infection of sound wood may occur.

The desirable slope for a foundation from front to rear is  $\frac{3}{4}$  inch for each foot of length, although some recommend a 1-inch slope for each foot for hardwoods. The surface of the foundation should be sloped so that the first tier of boards will lie flat on the foundation timber. The rear end of the foundation should at least be 12 inches above the ground level. When concrete is used the bottoms are made from blocks, either solid or built-up. One set of these supports comprises from three to five blocks set in a line and spaced at equal intervals. Three such bottoms are recommended for 12-foot, four for 16- and 20-foot, and five for 24-foot stock. They must be set below frost line, especially in clay soils, so that they will not be disturbed by frost heaving. The lumber is piled on 6- by 6-inch timbers placed on top of these bottom supports.



A type of built-up block is shown in Fig. 133.<sup>1</sup> The advantage of built-up blocks is that they can be moved more readily than solid blocks, and it is easy to build up a foundation to the level desired. Solid concrete bottoms extending for the entire pile width are not satisfactory because they retard the circulation of air.

Softwoods are often stacked in square or "box" piles while hardwoods are placed in narrow piles, preferably 6 feet in width. One acre will store approximately 1,000,000 board feet of 1-inch, 16-foot lumber when piled in squares and one hundred rounds high. This includes a reasonable allowance for dolly-ways and other unoccupied space.

Each runway is marked by some letter of the alphabet and the pile bottoms are numbered consecutively for ease in location. The designation of the former often is placed on a signboard at points of access,

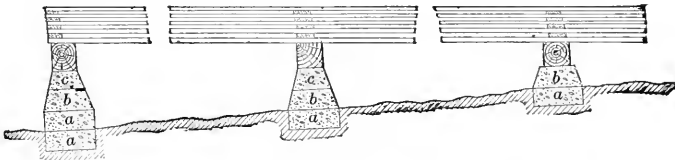

FIG. 133.—Built-up Concrete Foundations for Lumber Piles. The Blocks *a* are 16 by 16 Inches square and either 4 or 6 Inches in Height. Blocks *b* have a 16-by-16-inch Base 6 Inches high and a 12-by-12-inch Top. Blocks *c* have a Base 12 by 12 inches, a Top 8 by 8 inches, and a Height of 6 Inches. Timbers 6 by 6 or 6 by 8 Inches in Cross-section are placed on the Blocks and serve as Caps on which the Lumber is piled.

and the latter is painted on the front with white lead. By having each bottom clearly numbered much time is saved by truckers in locating given stacks of lumber.

### Piling Methods.

The best piling practice is to place lumber of the same length in a pile, because when various lengths are put together long boards will project from the end of the pile and, being unprotected, are liable to warp and check. As softwoods are sold largely in standard lengths, there is less lumber handling than would occur if random lengths were placed together.

Although hardwoods are sold in random lengths, many lumber manufacturers prefer to pile each length separately because there is less depreciation during seasoning. When random lengths are piled together

<sup>1</sup> A satisfactory mixture for foundation blocks is four parts of bank gravel to one part of cement. The forms should be made from D. & M. stock, and should be without top or bottom. Grease the forms with common black lubricating grease; turn molds, with the top end down, on a platform; fill with cement; and when the cement has set turn out on the platform to dry.

the ends of the interior boards may check badly unless they either rest on stickers or are 8 inches or more from them. This is not always possible unless the lengths are assorted.

The general practice in the Lake States is to separate the stock into two length classifications for piling—namely, 12 feet and under and 13 feet and over.

Boards are placed flat on the foundation and should be spaced from 1 to 2 inches apart to give ample space for the circulation of air. Two-by-4-inch dimension is sometimes piled on edge. This tends to prevent the pieces from acquiring "sweep" during seasoning. Dimension stock of Douglas fir and western larch, from 2-by-4-inch to 2-by-8-inch, often is piled flat with stickers between every second course. Since much of this stock is heart lumber it does not stain badly. It is claimed that 10,000 additional board feet can be put in an average pile by this method as compared to the practice of placing stickers between every course.

Lumber is occasionally piled on end in racks at storage yards. The advantage claimed for this method is cheapness in piling. So far as known the practice is followed only in rare instances.<sup>1</sup>

The different layers or courses of boards are separated one from the other by means of "stickers," which may be the same kind of material of which the pile is composed or seasoned strips of suitable size and length. It has been the general practice to "stick" low-grade coniferous lumber with the same class of material of which the pile is composed. This has the advantage that when the pile is torn down the stickers are taken along with the pile contents and there is no extra handling. This method is not satisfactory for the best grades of yard lumber because green lumber, when used as stickers, tends to increase the amount of sap stain present. For this reason 4- or 6-inch dry strips are preferred for this purpose. Hardwoods, as a rule, stay in the pile much longer than softwoods and there is a greater tendency to decay if proper precautions are not taken. It is customary to use sound, narrow, thoroughly dried stickers, often 1 by 1 inch or 1 by 2 inches in size. Stickers 4 or 6 inches in width are not often advocated for hardwoods because they may stain the lumber and produce checks and if they show signs of decay they also may be the center from which decay starts.<sup>2</sup> They should be placed directly over the foundation bottoms, and each succeeding sticker should be placed directly above the one below it, otherwise the pile may sag and cause the boards to lose their shape.<sup>3</sup>

<sup>1</sup> See *The Woodworker*, Dec., 1916, page 30.

<sup>2</sup> Some Lake States operators advise the use of 2-by-4-inch dry hemlock strips for the best grades of hardwoods. Some state that basswood, maple, and birch show more sticker marks, when dry stickers are used than when green ones are used.

<sup>3</sup> See Fig. 141.

Whether they should project beyond the front ends of the boards is still a mooted question. Some operators contend that the front end of each board should be drawn in about  $\frac{1}{2}$  inch so as to prevent end checking, while others advocate piling with the ends flush with the sticker, claiming that otherwise water will collect between the board and sticker and cause stain and decay. Others recommend placing the front ends of the boards slightly in advance of the stickers to prevent the entrance of water. The majority support the first method, both for softwoods and for hardwoods.

The rear sticker for hardwood boards which are to remain in the pile for two years or more should be at least 8 inches from the end because the loss from end checking is less than from rot occasioned by moisture collecting between the board and sticker. The rear sticker on softwood piles is placed about 2 feet from the rear ends of the boards since there is less end checking by this method.

As a protection against rain driving in at the front of the pile the various courses are drawn forward as the pile is built up so that there is an "overhang" of  $\frac{3}{4}$  or 1 inch to each foot vertical.<sup>1</sup>

The height of piles varies with the spaciousness of the piling area. Where there is ample space it is usual to pile 1-inch softwood lumber about one hundred courses above the tramway or level from which the lumber is handled. Other thicknesses are piled in the same ratio. This is as high as one man standing on the tramway can conveniently pass lumber up to the man on the pile. Hardwoods are not always piled so high because their greater weight tends to sink the stickers into the boards at the bottom of the pile. Some gum manufacturers recommend stacking only eighty rounds high. A "chimney" or open space from 12 to 15 inches wide is usually left in the center of "box" piles, especially during the rainy season, to aid in the circulation of air. They are not essential for narrow piles.

Piling lumber by hand methods requires two men, one on the pile to place the boards and stickers in position, the other to pass the boards to him from the tram level. A lumber jack, which serves as a fulcrum, is used to raise boards from the tramway or ground to the pile. One type of jack, Fig. 134a, consists of a tripod 4 feet high which has a central 4- by 4-inch upright, equipped with a spike point or some other form of sharp surface. A sliding arm having a vertical range of 12 or 15 inches sometimes is substituted for the fixed upright. It is held at the desired height by a bolt passed through a slot in the frame and a corre-

<sup>1</sup> Although the use of an "overhang" is very common, some condemn it on the grounds that it throws an undue weight on the front foundation skid which may cause it to sink, and also because it exposes the rear ends of the boards to the drip from the top of the pile. See American Lumberman, Dec. 31, 1921, page 1.

sponding slot in the arm. Another type of jack, Fig. 134*b*, consists of a steel bar  $\frac{1}{4}$  inch thick, 2 inches wide, and 4 feet long with one end turned at  $90^\circ$ , forming a sharp point about 1 inch in height. This is shoved from 12 to 15 inches into the front of a pile between two boards on a course, the projecting arm with the point serving as a fulcrum. Piling is usually done on a contract basis, the price paid per thousand feet being highest for "shorts" and lowest for 2-inch stock. Two

men can pile from 1600 to 2200 board feet per hour of 1-inch stock and from 2000 to 3000 board feet of 2-inch stock of standard lengths.

The hand-piling method is expensive when high piling is done and several mechanical devices have been put on the market for this work. One type has a metal spar with a long, narrow swivel bar. The latter with the spar attached is placed between two boards, several courses below the top of the pile, which serve to hold the spar upright. The block on the spar overhangs the pile so that by means of a second block attached near the base of the pile, and a rope, lumber may be hoisted up to the stackers by animal draft. A cradle or a pair of lumber tongs are used to hold the boards. A tele-

scopic spar, mounted on wheels, is also on the market. This works on the same principle as the system above described.

The lumber-piling machine shown in Fig. 135 is of special value when high piling is necessary. This machine has an endless chain elevator on which double brackets are placed at 4-foot intervals which are used either to elevate the lumber to the top of the pile for stacking, or to carry it to the ground when a stack is being taken down. The stacker is built in different sizes for maximum heights of from 24 to 40 feet. It is mounted either on flat wheels or on flanged wheels. The elevator chains are driven either by a 5-horse-power gasoline engine or by an electric motor. It requires three men for its operation and will handle 10,000 board feet per hour under favorable circumstances.

At plants equipped with a monorail system, lumber may be stored in the yards in piles composed of several units, placed one on top of the

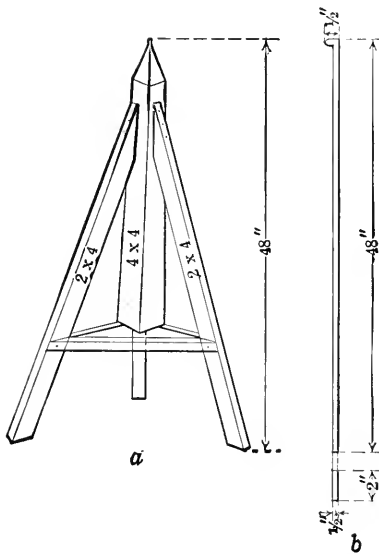

FIG. 134.—Lumber Jacks used in piling Lumber. *a*. A wooden-framed Jack. *b*. A metal Bar Jack.

other. These units are prepared at the assorting table, with stickers placed between each course of lumber, and are then piled under the monorail trestle or are carried to side piles by means of an overhead transfer. When the piles are broken up the lumber is handled in the original units, thus saving much hand labor. Lumber also may be elevated to the top of high piles by means of a locomotive crane, although this method is more commonly used for handling timbers.

When a pile is completed it is customary to mark, on the front of the pile, the grade, the size, the number of pieces, and the date the pile was completed. This is a great aid in taking inventory because the stock-taker has only to record the pile number and its contents. The date is an indication of the relative dryness of the stock.

### Pile-roofs.

Lumber piles should be roofed over during the winter or the rainy season to prevent the entrance of rain and snow into the interior of the pile, otherwise drying will be retarded. During the summer months some prefer to omit the roof because of the better circulation of air which may be secured if the top is not covered. High-grade hardwoods, however, should be protected against the direct rays of the sun, otherwise they will check and warp. Some do not put battens on the roofs of high-grade hardwood piles during the summer months, thus securing better air circulation.

The roof may be made of boards kept for that purpose. However, softwood manufacturers usually prefer to make the roof from the same kind of material as that in the pile so that when the lumber is moved, the roof also may be taken. In this way the yard can be kept cleaner,

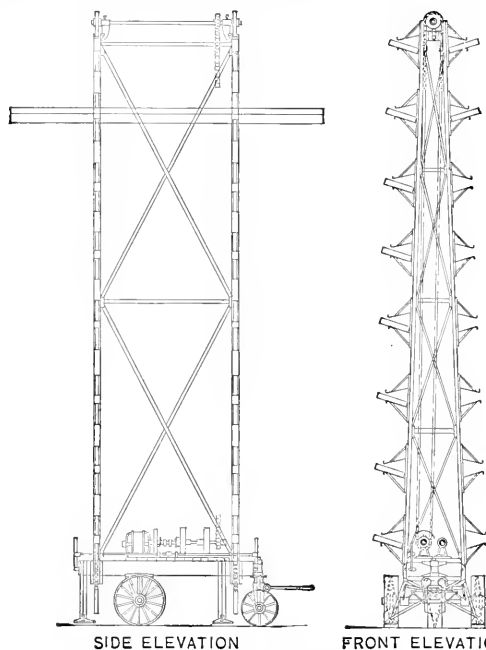

FIG. 135.—A Hilke Lumber Stacker used for High Piling and also to lower Boards when Piles are taken down. Power for driving the Elevator is provided either by an Electric Motor or by a Gasoline Engine.

and the roof boards are sold before they become so badly damaged that they have no market value.

The roof should project at least 18 inches over the front of the pile, and far enough over the rear so that the drip will not strike the lower courses of boards. Twelve-foot piles should be covered with 16-foot boards and on 14- and 16-foot piles the boards should be lapped to secure the necessary length. Cracks between roof boards may be battened with 6-inch strips. The pitch of the roof is secured by three or four roof boards placed over the front of the pile, two boards over the middle of the pile, and one roof board over the rear sticker.

Cross strips are placed over the roof near the front and rear ends, when there is danger that the wind will blow off the roof boards. These strips may be fastened either by (a) suspending weights from the strip ends by means of wire or cord; (b) placing a short board between the courses about 2 feet below the roof, passing an endless wire over the ends of the strip and the short board and tightening the wire by twisting the

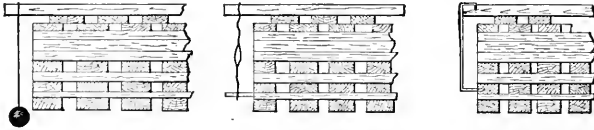

FIG. 136.—Three Methods of holding down Lumber Pile Roofs.

strands with a stick; or (c) using a hook one end of which is caught on the top of the cross strip and the lower end driven into one of the boards in a course below.<sup>1</sup>

### Pole-stacking.

Green boards of cottonwood, yellow poplar, and basswood have a tendency to stain when they are placed in a pile direct from the saw. Large mills avoid this, in part, by seasoning sap lumber in a dry kiln. Some of the large mills and many of the small ones overcome this difficulty by pole-stacking the lumber for a short time before placing it in the pile. A pole or piece of dimension, supported on a frame work at a height of about 8 feet above ground, serves as a rack against which the boards are leaned edgewise, one end resting on the ground. An air space between boards is secured by alternating the pieces on opposite sides of the rack.

<sup>1</sup> See Fig. 136.

### Shed-seasoning.

High-grade hardwoods, especially hard maple, are sometimes seasoned under open sheds.<sup>1</sup> The lumber is piled on end at a slight angle, each course of boards being separated by three 1- by 1-inch stickers, one on the floor, one 6 feet from the floor, and one at 12 feet from the floor. The middle and top stickers rest on 1- by 4-inch girders attached to studding and are held in place by wire nails. Sun and rain tend to check and warp the edges of the outer boards and this may be avoided by placing a narrow cull board on the outer edge of each course.

The advantages claimed for shed-drying are freedom from end checks, sap and weather stain, and comparative freedom from sticker marks for which reasons lumber dried in sheds commands a premium over that dried in flat piles in the open. The cost of drying by this method, however, is greater than by the flat-piling method.

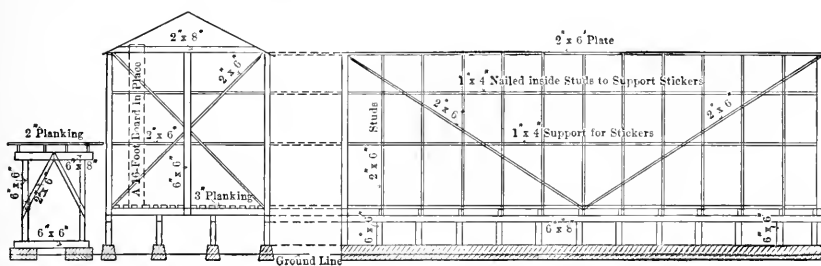

FIG. 137.—The Framework of an Open Shed for seasoning Hardwood Lumber.

Aside from the shed foundations and the sills and joists which support the piles, a shed for end-piling may be of comparatively light and cheap construction, provided it sheds water. A type of shed<sup>2</sup> used by a Michigan operator and advocated by him where a substantial building is desired is shown in Fig. 137. The concrete foundations, 10 inches wide at the top and 14 inches wide at the base, are made solid and run the full length of the building. The bases of the floor joists are 4 feet above the ground level so as to insure a good circulation of air underneath.

The building is constructed in units 48 feet in length, in order that it may be suitably braced as shown in the end section. This method also permits the removal of lumber from a seasoned section without interfering with the piling of green lumber in other sections. A permanent

<sup>1</sup> This practice is followed chiefly by Michigan operators. Manufacturers in the Memphis, Tenn., district, have used sheds for end-piling lumber especially for thin-sawed oak and gum.

<sup>2</sup> See *Hardwood Record*, July 10, 1909, page 24.

roof may be made by the use of boards covered with some form of properly coated felt roofing.

End-piling of green redwood under sheds also is reported from California, although this practice cannot be regarded as common.

### Shed Storage.

A few mills in the Northwest store partially air-seasoned lumber in large sheds during the rainy season in order that yard stock may be available at all times for shipment. The high humidity during the winter months slows up the air-seasoning process and much of the yard stock cannot be satisfactorily worked in a planing mill unless it is stored under cover. This method obviates a practice, somewhat common in the region, to work yard stock into standard patterns during the summer period. Since market requirements as to character of stock cannot be readily forecast, the market sometimes becomes glutted with certain classes of stock and short on others, when this practice is followed. The shed storage method, therefore, places those who practice it in an advantageous position to convert their stock into the class of material most in demand.

### Prevention of End-checking.

Wide boards have a tendency to split at the ends during the seasoning process. This causes a heavy quantity loss in high-grade stock unless steps are taken to prevent it. Many operators nail dry strips across

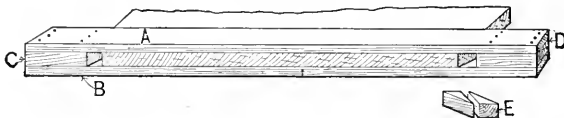

FIG. 138.—A Frame for preventing End Splits on Wide Boards.

the ends of green boards to protect them from the direct rays of the sun. Another method recommended for wide, yellow poplar and equally applicable to any other wood is shown in Fig. 138. This consists of a frame made of two boards, A and B, each  $\frac{1}{2}$  by 4 inches in cross-section and of a length sufficient for the width of boards to be seasoned, between the ends of which are nailed the blocks C and D, the thickness of which corresponds to the thickness of the boards. When the frames are made up, only block C is nailed to the strips A and B, the block D being put in place and nailed after the frame has been slipped over the end of the board. Ample space is left between the edges of the board and the blocks to allow the double wedge E to be inserted. These wedges are made from 4- by 8-inch dry stock S 4 S, and ripped



diagonally. A set of wedges is placed between each edge of the board and the blocks and as the board shrinks the wedges are driven in so that they are always tight. The lumber is stacked in piles one board wide, with five 1-inch stickers to each board. The strip *A* on one board and the strip *B* on the board above it serve as stickers on each end.

Thick hardwood stock, especially oak, tends to check badly on the ends. To prevent this the front of the pile is sometimes covered with cull lumber, which shuts off the direct rays of the sun.

Coating the ends of large timbers and heavy dimension with some sort of filler will largely prevent checking during the seasoning process. A brush treatment of paint, whitewash, or some special preparation is most frequently used. The white lead in paint, however, becomes hard in the course of time and tends to dull the planer knives, while whitewash wears off in a few months and has to be renewed. A "filler" which is more satisfactory than either paint or whitewash may be made according to the following formula: one pint of glue in solution and three pounds of salt, to three-fourths of a barrel of whitewash.<sup>1</sup> This filler will last for two years.

#### Use of Salt in Seasoning Lumber.

Common coarse salt is sometimes sprinkled over the surface of hardwood lumber to prevent checking during the process of seasoning. This practice is not common, however, and its value is questionable. The salt, being deliquescent in character, keeps the surface of the board moist for a considerable period and by this means may retard checking to some degree. Its effect is temporary in character only.

#### Time Required for Air-seasoning.

The rate of seasoning is dependent on the structure of the wood itself and its moisture content when green and also upon the relative humidity and the temperature of the air.

In general, the lower the humidity of the surrounding atmosphere, the faster lumber will dry and the drier it will become. However, the rate of drying also is influenced by temperature since the higher the temperature of the air, the more moisture it can take up before becoming saturated. Because of this relation of humidity and temperature to the rate of seasoning, lumber will reach an air-dried condition in a shorter time during the spring and summer months than during other periods of the year, and it will reach a lower moisture content in "dry" climates than in "moist" ones.

<sup>1</sup> See *Hardwood Record*, Aug. 25, 1920, page 20.

Humidity conditions vary in every region at different seasons of the year and since wood gives off or takes on moisture with a rise or fall in humidity and temperature, the per cent of moisture in so-called air-dried wood varies at different seasons of the year.<sup>1</sup> It can be held constant only by a control of the humidity conditions. In the Douglas fir region, lumber air-dried during the winter will contain from 16 to 18 per cent of moisture, while lumber dried under favorable conditions during the spring and summer months may contain from 10 to 12 per cent only.<sup>2</sup>

Air-dried lumber in the semi-arid regions, because of the lower humidity and higher temperature, will contain less moisture at all seasons than in other regions which have a greater rainfall.

The range in moisture-content in air-dried lumber varies, therefore, with the climate and the time of year, and is from 8 to 18 per cent.<sup>3, 4</sup>

Lumber in a so-called "shipping dry" condition and containing several per cent more moisture than completely air-dried stock may be shipped when the demand for lumber is brisk. Since air-dried softwood lumber is largely used in general construction work, the slight shrinkage accompanying the final loss of the excess moisture is of minor importance from the standpoint of use. However, "shipping dry" lumber is unsatisfactory when worked to some pattern where a close-fitting joint is required because further shrinkage will occur.

Hardwoods are largely consumed by wood-using industries which require a product with a low moisture content. This can rarely be attained by air drying. Hardwoods are more difficult to season in a dry-kiln than softwoods and many mills are not equipped to do it satisfactorily. The lumber, therefore, is usually shipped to the wood-using plant in a "shipping dry" condition and the final seasoning done at the point of re-manufacture. The lumber manufacturer is enabled by this means to move his stock more rapidly and he also reduces his losses during the process of drying.

Under favorable drying conditions, 1-inch Douglas fir lumber will reach a "shipping dry" condition in from forty-five to sixty days, while during the winter season from ninety to one hundred and twenty days are required. Two-inch stock requires from one hundred and eighty to two hundred and forty days. Southern yellow pine 1-inch stock requires from forty-five to sixty days during the spring and summer and from seventy-five to ninety days during the winter.

<sup>1</sup> The standard for comparison is lumber thoroughly oven-dried at 212° F.

<sup>2</sup> See Lumber Manufacture in the Douglas Fir Region, by H. B. Oakleaf, Lumber, July 5, 1920, page 52.

<sup>3</sup> See The Kiln Drying of Lumber, by H. D. Tiemann, page 3.

<sup>4</sup> See Relation of Moisture Content and Drying Rate of Wood to Humidity of Atmosphere, by Arthur Koehler, American Lumberman, July 12, 1920, page 54.

The determination of the degree of dryness of lumber in a pile, at most plants, is largely guess work. The operator's opinion is influenced by the length of time the lumber has been in the pile and by certain rule-of-thumb methods which often are misleading. The only sure method is to actually determine the relation between the weight of test pieces, before and after being oven-dried. This is a simple process, but the test is rarely made, for it is little understood and its value is not appreciated.<sup>1</sup>

### Prevention of Sap Stain.

The sapwood of many species is subject to sap stain during the process of seasoning. This is due to the growth of a fungus which feeds on the cellular contents, but does not affect the cell walls during the early stages of development. The appearance rather than the strength of the wood, therefore, is affected. The stained color of the sapwood is due to the color of the fungus organism visible through the cell walls, and according to the kind of fungus, may be blue, blue-black, gray-brown, green, or red. The blue and blue-black colors are most common and give rise to the general term "blue-stain." Red stains are not common in conifers, although they do occur frequently in Sitka spruce.

There are some stains not due to fungi, the cause of which is not fully understood. They are thought to be due to a chemical change or oxidization of the ingredients of the cells. The color produced by them, a dirty light-to-dark-brown, shows on some of the western soft pines, appearing both on kiln-dried and air-dried stock. The strength of the wood apparently is not affected.<sup>2</sup>

The staining of sapwood is most common in yard stock in southern yellow pine, North Carolina pine, western yellow pine, and in fact all species of conifers and hardwoods which have a large per cent of sapwood. Heartwood is not affected because the cells do not contain sugars, starches, and oils on which the fungus develops.

The staining process is most active during moist, warm weather and will usually appear at such times on freshly cut sapwood within a day or two after the lumber has left the saw, unless it has been properly piled or treated with some chemical which prevents its development. It is much less prevalent during the winter months but may appear during warm humid weather, even at that time of the year.

<sup>1</sup> A simple method of determining the moisture per cent is given in the Appendix, page 505.

<sup>2</sup> See Dipping Treatment for Prevention of Sap Stain, Timberman, May, 1919, page 35.

As early as 1888, lumber manufacturers were attempting to solve the problem by the use of lime sprinkled upon the lumber, by depositing lime under the piles, and by sprinkling weak lime water upon the surface of boards. None of these practices gave satisfactory results.

On December 15, 1903, George C. Cowles of Bay Mills, Michigan, was granted the first patent on a process to prevent sap stain.<sup>1</sup> The chief feature of this patent was the immersion of the lumber in a 5 per cent solution of bicarbonate of soda ( $\text{NaHCO}_3$ ). This patent was declared invalid by the Circuit Court for the Western District of Michigan, on July 23, 1908, on the basis that it did not embrace any new patentable ideas.<sup>2</sup>

The U. S. Forest Products Laboratory conducted experiments some years ago with various chemicals, to determine their efficiency in preventing sap stain.<sup>3</sup> Mercuric chloride solutions were found to be more effective than any others tried, but on account of their poisonous nature they were not recommended for use.

Sodium bicarbonate ( $\text{NaHCO}_3$ ) proved to be a satisfactory chemical for general use. Although less effective than some others its relative cheapness and harmless character strongly recommend it, and it is the chemical now in use at sawmill plants. It is used in varying strengths, a common mixture for southern yellow pine lumber being 25 pounds of soda to 52 gallons of water (approximately a 5.75 per cent solution). Thirty-five pounds of soda to 52 gallons of water (8.75 per cent solution) often are used for red gum and similar woods. When soda first came into extensive use it was a common practice to add oxalic acid crystals to the solution. This served as a mild bleach, but since the results were of doubtful value and greater quantities of  $\text{NaHCO}_3$  had to be used to neutralize the effect of the acid, this practice has been discontinued. The soda is dissolved in 250-gallon tanks and is then run into the dipping vats, one type of which is shown in Fig. 139. The dipping tank, built in any suitable length, is placed near the head of the assorting table, and is provided with a by-pass *A* supported on two I-beams resting on the ends of the tank. The by-pass permits the separation of the lumber which is to be kiln-dried from that which is to be air-seasoned. Usually the latter, only, is immersed in the solution. The by-pass has several arms placed on a common shaft, all arms being raised and lowered by a hand-operated lever. The drip from the dipped lumber is collected and returned to the tank by an inclined drain-pan

<sup>1</sup> Letters Patent No. 746,678.

<sup>2</sup> Lumber Anti-Stain Co. *vs.* Geo. Nester, John Nester, *et al.*

<sup>3</sup> See The Prevention of Sap Stain in Lumber, by H. F. Weiss and C. T. Barnum, U. S. Dept. of Agriculture, Forest Service, Circular 192, 1911.

placed at the far side of the tank up which the dipped lumber passes on its way to the assorting table.

The solution should be kept at a temperature of approximately 140° F. which is accomplished by means of a live-steam coil placed in the bottom of the tank.

Most of the sawdust from the edging and trimming processes, which is on the boards when they fall upon the skids *C*, is collected in the dust spout. Some, however, is carried over into the vat, and the accumulations should be removed from the tank every few days. This is accomplished by draining the solution from the tank through the pipe *D*, and later returning it to the tank for further use. It requires about 4.5 pounds of soda to dip 1000 board feet of lumber when the work is efficiently done and there is no waste of the drip.

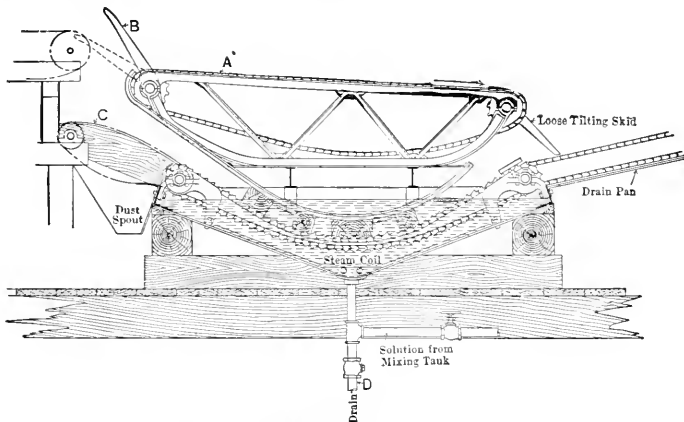

FIG. 139.—The Cross-section of a Metal Tank used in dipping Lumber to prevent Sap Stain. *A*. A By-pass for Lumber which is not dipped. *B*. One of the Arms which span the Gap between the Assorting Table and the By-pass. *C*. One of the Skids on which the Lumber drops as it passes through the Tank.

All lumber may be dipped at mills having a limited output in which case the by-pass feature of the tank is omitted. Various home-made tanks are in use, many of them made from planks. The lumber is usually held against the conveyor chains by some form of suspended idler wheels, the lumber passing under the rim of the wheels and riding on top of the chain.

Dipped stock must be open-piled so that there will be ample ventilation, and dry stickers should be used. Lumber left in solid piles for some days before "sticking" or lumber which has been rained upon, will stain even though dipped. One objection raised against dipped lumber is that the boards dull the planing-machine knives. There is a difference of opinion on this subject, however, and it is certain that the

advantages of having "bright" lumber more than counterbalance any difficulties which may arise from re-working the seasoned material in the planing mill.

Workers on the assorting table sometimes are averse to handling wet lumber, especially during cold weather. For this reason and also because there is less danger of sap stain during the winter months, the process often is abandoned during cold weather.

When dipped lumber was first put on the Belgian and German markets there were complaints from importers, because they claimed there was a slight discoloration of the lumber caused by the soda; however, this objection is no longer raised.

### Yard Sanitation.<sup>1</sup>

Much can be done to prevent the deterioration of lumber stored in the yards or sheds by maintaining a high standard in yard sanitation. The degree to which sap stain and decay occur and spread is governed largely by the rapidity of drying and the presence or absence of centers of infection.

Sound wood is infected either by the spores of fungi, which are blown about by the wind, or by the direct over-growth of mycelium from decayed wood.

Debris, such as partially decayed pile foundations, and tram timbers, and broken boards and stickers, not only furnishes ideal conditions for the growth and development of wood-destroying fungi but also constitutes a relatively high fire risk. An untidy yard also reacts upon the workmen, who take less interest in doing their work properly when neglect is apparent in the yard management. This is illustrated by the lumber pile shown in Fig. 140, in which the stickers are carelessly placed, not only with reference to the foundation pieces but also with reference to one another. Another pile of lumber shown in Fig. 141 consists of low-grade stock, many boards of which have been ruined by the careless manner in which the stickers were placed. The roof also has been poorly constructed.

There is a great difference in the cleanliness of lumber storage yards and the care with which lumber is piled and cared for, and there is as great a relative difference in the extent to which decay is found in them.

The requirements for proper yard sanitation are:

1. Location of the yard on high and dry ground, preferably on mineral soil.

<sup>1</sup> See *The Timber Storage Conditions in the Eastern and Southern States with Special Reference to Decay Problems*, by C. J. Humphrey, U. S. Dept of Agriculture, Bul. No. 510, Washington, May 17, 1917.

2. Elimination of all rank growth of weeds and grass, because they retard the circulation of air and prevent the rapid drying of lumber.



FIG. 140.—A Lumber Pile Foundation which has been poorly constructed and the Surroundings of which are in an Insanitary Condition.



FIG. 141.—Low-grade Lumber piled in a Careless Manner. Note the Irregularity of the Stickers, the Warped Boards, and the Insanitary Condition of the Surroundings.

This may be accomplished either by mowing the weeds and grass at frequent intervals, or by spraying them with some solution. Weeds can be kept under control by applying twice a year, a solution composed of

125 pounds of common salt dissolved in 52 gallons of water, when the weeds are comparatively young. One barrel per acre is sufficient. A 2.5 per cent solution of sulphuric acid is more effective, but it also costs more and is less safe to handle.

3. Use of dry piling strips, which, when not in use, should be kept on racks where they will remain dry.

4. Elimination of wooden pile foundations.

5. Construction of the foundations high enough above the ground, and open enough to permit a good circulation of air under the pile.

6. Piling the lumber so that rapid drying can take place.

7. Treating of tramway timbers with creosote to prevent infection.

8. Elimination of rubbish in the yard by collecting it at frequent intervals and burning it.

9. Treatment of sap lumber with some solution which will aid in the prevention of sap stain.

#### DRY-KILN SEASONING<sup>1</sup>

##### Development.

The early development of the idea of using artificial heat for hastening the drying process at the sawmill plant came in the southern pineries when lumber manufacturers in those regions began to seek extensive markets outside of the producing territory. The demand was limited and only the choice portions of the heart-wood were considered merchantable when the market was local. The sapwood, which comprises a considerable per cent of the log, especially in second-growth pine forests, was of high quality but stained so badly during the process of air-seasoning that it could not be sold in northern markets in competition with eastern white pine, eastern spruce, and other woods which were comparatively free from this defect.

This was especially true in the Boston, New York, Baltimore, and Philadelphia markets to which lumber was shipped by water in large quantities from Virginia and the Carolinas. The operators in this section found themselves under such a great handicap in marketing their stained sap lumber in competition with spruce and hemlock that about 1879 a firm near Norfolk, Virginia, installed some primitive kilns to season their product. The idea was rapidly adopted by the pine manufacturers throughout the region and somewhat later also was adopted by operators in other parts of the southern pine region who were attempting to establish a market for their product in the northern interior states. Improvements in equipment rapidly followed and

<sup>1</sup> See *The Kiln Drying of Lumber*, by H. D. Tiemann, for an extensive treatise on this subject.



during the course of the next three decades many patents for lumber dryers were placed on the market. However, a large per cent of them were never adopted by the trade.

Lumbermen first used artificial methods of drying in order to prevent the deterioration of the quality of the stock, but they soon found other advantages resulted from this practice, one of them being greater rapidity in seasoning. This enabled them to place their product on the market in a much shorter time than was possible with the air-seasoning method. The importance of this became more apparent as the size of individual operations expanded and it became necessary to carry large stocks of yard lumber to meet trade requirements. This necessitated a large investment to carry the stock, and also increased the possibility of a heavy loss in case of fire, both of which factors could be reduced by a shorter drying period. The ability to lower the moisture content of lumber to the minimum by kiln-drying was of special value to operators who had a relatively long haul to market and whose lumber was rather heavy as compared to that of their competitors, since the lumber product often was sold at a delivered price, the freight charges being based on weight and not on volume.

The possibility of weight reduction has been of special importance to operators in the Northwest, especially on their eastern shipments. By the thorough kiln-drying of their output they are able to reduce the shipping weight of their products to a point below the "standard" shipping weights, thereby making a small profit on freight rates. At some periods the main profit in the industry has come from the so-called "underweights." The introduction of dry kilns also was a factor in the development of the practice of re-manufacturing softwood lumber at the sawmill plant into the final form of products required by the building trades. To make a satisfactory matched product, it is essential that the product shall not shrink further after it has been worked. Since the per cent of moisture in air-dried stock varies with the season of the year, and is high during the winter period, satisfactory planing-mill stock was not available throughout the year and, therefore, it was not practicable to build up and maintain a trade in high-grade finished products. The dry kiln has made this possible because stock of suitable dryness can be made available at any season of the year.

The artificial seasoning of hardwoods at the sawmill plant has never attained the importance that it has at softwood plants because hardwoods, as a rule, have a more complex physical structure, and the type of kiln adapted to seasoning softwoods was not well suited for most of the hardwoods. The unsatisfactory results obtained with hardwoods, for many years, deterred operators from using artificial seasoning methods, except in the case of the sapwood of such species as yellow

poplar which can be easily kiln-dried and which stains badly if not promptly seasoned.

The objects sought in kiln-drying lumber at sawmill plants are:

1. To prevent the deterioration of the better grades of lumber due to the discoloration of the sapwood.
2. To reduce the time required to get lumber into a shipping condition and thus permit a more rapid turn-over of the stock.
3. To reduce the shipping weight of lumber to a point below that which is possible with air-seasoning.
4. To reduce the moisture content of lumber to a point where it can be manufactured into products, the final use of which demands a low moisture content.

Softwoods are dried directly from the saw since speed in drying is the chief object sought. Hardwoods, on the other hand, are often partially air-dried before being placed in the kiln, and lower temperatures are generally used. However, the results of many years' experimental work on the part of Tiemann and others at the U. S. Forest Products Laboratory has demonstrated that all woods, if properly handled, can best be dried directly from the saw, since throughout the entire period the drying conditions can be controlled absolutely.

In spite of the fact that the art of kiln-drying lumber is more highly developed in the United States than in any other country there is no standard practice even for the same species and for the same type of kiln, except in the case of the Tiemann. The operation of the kiln often is left to the care of those who are unfamiliar with the rudimentary principles of kiln-drying lumber, and were it not for the fact that most coniferous woods, during artificial seasoning, will stand much abuse before they actually become unmerchantable, the practice of seasoning softwoods in dry kilns would be less common than it is to-day.<sup>1</sup> Hardwoods require careful control of humidity and tempera-

<sup>1</sup>Some firms do not have a special man to supervise the dry-kiln operation. At a conference on dry-kiln practice held by southern pine operators it was brought out that there was a seeming lack of policy in regard to handling dry kilns even on the part of operators controlling several mills. One firm having three mills on the same railroad all cutting the same class of timber, two of which mills secured their timber from the same tract, reported that the dry kiln work at one plant, only, was supervised by a special kiln operator. The average shipping weight of lumber at this plant was 3000 pounds per thousand board feet. The average shipping weight of lumber at the other two plants was 3200 and 3400 pounds respectively. On the basis of a 35-cent freight rate, Mill No. 2 spends 70 cents and Mill No. 3, \$1.40 per thousand board feet more for distributing lumber than Mill No. 1. Assuming that 40 per cent of the output of each mill was kiln-dried, and that the annual cut was 25,000,000 board feet, the employment of a special kiln man at Mill No. 1 produced a net profit of \$7000 above that at Mill No. 2 and \$14,000 above that at Mill No. 3, on the basis of weight alone. See *American Lumberman*, Jan. 16, 1915, page 53.

ture during drying if the product is satisfactorily dried. Since kilns which permit such control have been available only recently, the successful artificial seasoning of hardwoods has lagged behind that for softwoods.

The variation in the kiln-drying methods followed in the southern pine region with the progressive type of moist-air ventilated dry kiln illustrates the lack of uniformity of procedure at sawmill plants. The range in temperature carried in the kilns varies from 140° to 225° F., and the time of drying ranges from 24 to 96 hours for common and for heart lumber, and from 40 to 168 hours for sap and select lumber. The results of drying are as variable as the temperature and time. The tests made showed that from 2 to 26 per cent of common lumber and from 3 to 20 per cent of select lumber was degraded during the seasoning process.<sup>1</sup>

### Classification of Dry Kilns.

The various types of dry kilns may be classified under three main heads—namely, dry-air, moist-air, and superheated-steam, depending upon the character of heat employed.<sup>2</sup>

1. Dry-air
  - (a) "Smoke"
  - (b) Furnace
2. Moist-air
  - (a) External circulation, partly returned
    - (1) Ventilated
    - (2) Forced draft or blower
  - (b) Internal circulation
    - (1) Condensing
    - (2) Humidity water-spray
    - (3) Humidity-regulated steam-spray
  - (c) Oven or boiling
3. Superheated-steam
  - (a) High superheat, forced draft
  - (b) Low superheat, high velocity, internal circulation.

The dry-air type was formerly used extensively at sawmill plants, but is now rarely found except at small operations. The chief type of kiln in use is the external circulation, ventilated type of moist-air kiln, although the "oven" or boiling type is in use at some mills in the Northwest

<sup>1</sup> See a report of the Committee on Dry Kiln Practice of the Southern Pine Association, at the Annual Meeting, Feb. 23 and 24, 1916. Lumber Trade Journal, March 1, 1916, page 44.

<sup>2</sup> See The Kiln Drying of Lumber, by H. D. Tiemann.

and the "humidity water-spray kiln" is coming into use, especially at hardwood plants.

Dry kilns may be operated as progressive or compartment kilns. In the former case the charge of lumber present at any given time represents varying degrees of dryness from the green or charge end to the dry or discharge end of the kiln. The procedure followed is to remove one or more kiln-truck loads of lumber from the dry end, then advance the remaining loaded trucks in the kiln until the emptied space is again filled, following which, cars of green lumber are placed in the charge or green end.

In the compartment type of kiln, the entire charge remains in the chamber until it is dried to the point desired, when it is removed and the kiln again charged.

The relative merits of the two systems are as follows:

### **Progressive Type.**

1. The progressive kiln requires less skill to operate than the compartment type and therefore cheaper labor may be used. In the past, this has been regarded as an important feature at softwood plants because of the lack of properly trained kiln attendants.

2. The progressive type is adapted to seasoning lumber which may be easily dried, such as southern yellow pine, Douglas fir, and many of the other conifers. It usually is the practice to season these woods, green from the saw, and since large quantities of material of a given thickness are seasoned, each kiln can be charged with lumber of one thickness only. It also may be used for drying some hardwoods whose structures are more or less uniform and which do not require intensive methods of kiln operation to secure satisfactory results.

3. The steam consumption in drying green lumber often is less than in the compartment type, although economy is of minor importance at many sawmill plants where steam is produced in ample quantities from mill refuse.

### **Compartment Type.**

1. Drying conditions can be more readily regulated than in the progressive type and, therefore, this is the one best adapted for use where careful control of temperature, humidity, and circulation is necessary to secure satisfactory results.

2. Drying conditions can be altered at any stage of the seasoning process in order to prevent case-hardening or to give stock any special treatment. It is a more flexible system than the progressive type and is the method best adapted for seasoning refractory hardwoods.

3. The drying capacity of this type of kiln may be as great as that of the progressive type.<sup>1</sup>

### Dry-air Kilns.

*"Smoke."*—This type of kiln known as the smoke kiln or the Arkansas dry kiln, was the earliest form used and may yet be found at small sawmill operations in the southern pineries. Its chief merits are cheapness of construction and the fact that fair drying results may be secured at small expense.

This kiln consists of a square boarded enclosure, often 16 by 16 feet in size and from 16 to 20 feet high, without a roof. On the inside there is an open framework about 8 feet high which furnishes a base on which the lumber is piled flat, or occasionally on edge, with a spacing between boards of about 2 inches. The courses of boards are separated by stickers so as to allow for air circulation. Lumber is brought to the kiln on a tramway which is level with the piling floor in the kiln. To facilitate loading and unloading the kiln the side next to the tram is removable. An entrance on the ground level affords access to the fire pit.

The fire is placed under the framework in two "barbecue," trenches, and the heat and smoke pass up through the lumber and out the top. A smoke kiln represents a high fire risk and therefore should be placed at some distance from the yard and the mill.

A kiln of this kind will dry lumber fairly well in one week's time. However, drying does not take place uniformly throughout the pile and the surface of the lumber is badly discolored. The discoloration disappears, for the most part, when the lumber is surfaced, and so-called "smoke-dried finish" has, at times, commanded a small premium because of its somewhat darker, yellowish color.

*Furnace.*—The furnace kiln represents the second stage in the development of dry kilns at sawmills, and early supplanted the smoke type at large operations. It has a single drying room often from 75 to 100 feet long and 20 feet wide, with elevated tracks, supported upon brick columns, on which the dry kiln trucks travel. The track is about 8 feet above the ground level and the clearance between the tracks and the roof is 12 or 13 feet.

An iron drum about 36 inches in diameter with a smoke outlet to an outside chimney, placed midway between the two ends of the drum, runs lengthwise through the center of the kiln at the ground level.

<sup>1</sup>An excellent discussion of this subject, entitled, "Kiln Drying Systems Compared," by H. D. Tiemann, may be found in the *Hardwood Record*, Sept. 10, 1920, pages 15-23.

Iron or brick furnaces, with their fire doors opening to the exterior at right angles to the main axis of the drum, are connected to the latter by short pipes. The heat from the furnaces passes through the drum to the center of the kiln and then out through the stack. Mill refuse, chiefly slabs, is used for fuel.

While this form is an improvement over the smoke kiln, it is not a satisfactory method of drying lumber because there is no humidity control and lumber often is badly checked.

### Moist-air Kilns.

*Ventilated.*—This type of kiln, Fig. 142, is the one in most common use at softwood plants. The kilns are usually arranged in batteries of two or three rooms, sometimes more, since this reduces the

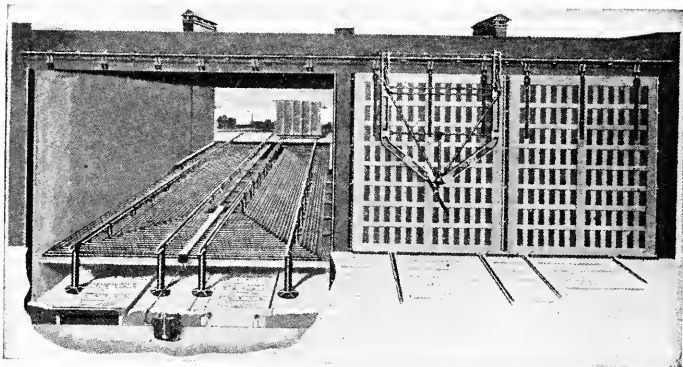

*By permission Standard Dry Kiln Co.*

FIG. 142.—A Progressive Dry Kiln showing the Arrangement of Pipes and Rails in the Heating Chamber and also a Patent Door Carrier.

cost of construction, lessens the loss of heat by radiation, and economizes space. The drying rooms vary in size in accordance with the piling practice. If the lumber is placed on the trucks so that the lumber enters the kiln lengthwise the kilns often are all of the same width, while if lumber is cross piled, it is usual to have kilns of several widths to accommodate the different lengths of stock. The buildings are from 90 to 120 feet in length and have an inside clearance from rail to ceiling of 12 or 13 feet. The walls are made of brick, concrete, or hollow tile, and the roof of wood or tile, preferably the latter.

Kilns for cross-piling are equipped with three steel rails running the full length of the drying room, while for end-piling two sets of tracks with a 6-foot gauge are usually provided in each room. These tracks are elevated on metal supports from 3 to 6 feet high, the tracks sloping

from  $\frac{2}{16}$  to  $\frac{3}{16}$  inch for each foot in length from the receiving end to the discharging end, to facilitate handling cars.

The kilns are heated by a series of 1- or  $1\frac{1}{4}$ -inch wrought-iron pipes usually placed below the kiln tracks, and running parallel to them, although in some cases, pipes also may be placed along the sides of the drying room. The pipes are commonly arranged in horizontal or vertical layers and so spaced that they are accessible for repairs. The pipes at the loading end of the kiln are connected with one or more supply headers, and at the discharge end they are also connected with a similar header or headers which collect the condensed water, which flows into them by gravity. This water is then carried by pipes to a steam-trap or to a tank to which a pump is connected and the water either discharged into the open air or into the boilers and used as feed water.<sup>1</sup>

The number of linear feet of pipe in a kiln varies with the size of the kiln, the character of kiln construction, the climate, and the kind of steam supplied.<sup>2</sup> When low-pressure exhaust steam is used, twice as much piping is required as is necessary when steam is taken direct from the boiler.

A common form of moist-air kiln draws cold air from the exterior through a wooden duct which extends from the discharge end to a distance of one-third to one-half of the kiln length. The amount of air admitted is controlled by a damper. The air passes upward from this duct between the heating pipes, then through the lumber in a more or less horizontal direction to the opposite end of the kiln where the moist air is discharged through a series of openings in the side walls or in the ceiling.

The circulation of air from the discharge end to the loading end keeps the moisture in the "green" end of the kiln which prevents stock from drying too rapidly. The moisture is obtained chiefly from the lumber itself. Some kilns are equipped with jets for the admission of live steam to the heating chamber, although it is seldom used by the kiln operator.

There is some variation in different kilns in the arrangement of the points of air entrance and exit; for example, in one type of kiln the cold air is admitted at the ceiling and the moist air discharged below the lumber, a more logical arrangement than the one first described because

<sup>1</sup>See pages 237 to 239.

<sup>2</sup>Tiemann gives the following general rule for the amount of heating surface: For drying at from 180° to 220° F., with boiler pressure, use 1 foot of 1-inch pipe for every 2 cubic feet of air space above the pipes. This is equivalent to approximately 0.1725 square foot of heating surface for each cubic foot of space. See *The Kiln Drying of Lumber*, by H. D. Tiemann, page 59.

the natural tendency of air passing through moist lumber is downward. Moist-air ventilated kilns usually are operated by the progressive method.

*Forced Draft or Blower.*—This type of kiln has the heating apparatus outside of the kiln room proper, the heated air either being forced into or sucked out of the drying room by means of a fan. Humidity is maintained by re-circulating a portion of the air, outside air being admitted and moist air expelled as necessary. Sometimes a closed circuit is used and the surplus moisture removed by condensers. A drawback to this type is the difficulty of producing a uniform circulation of air throughout the lumber piles which may lead to uneven drying.

The blower kiln is used chiefly at wood-working plants for drying hardwoods where relatively low temperatures and slow drying have been essential to success in seasoning hardwoods in external circulation kilns. It is not in common use at sawmill plants.

*Condensing.*—This type is in limited use at sawmill plants. The circulation of the air is brought about by means of gravity due to the differences in air density caused by the heating and cooling of the air. The heating pipes are commonly located beneath the lumber and the condensing pipes placed along the side walls. Cold water in rather large quantities is required for use in the condensers since not only the moisture evaporated from the wood must be condensed, but also a certain amount of heat is extracted from the air as it passes over the condenser. The pipes rust out quickly and condensers are troublesome on that account.

The humidity is controlled in these kilns by increasing or decreasing the flow of cold water through the condenser. This type is sometimes used as a progressive kiln, although it is generally operated as a compartment kiln.

*Humidity Water-spray.*—This type of internal circulation kiln gives promise of being extensively used for drying lumber. One of the chief features of the humidity water-spray kiln is the principle of forced air circulation and humidity control by means of water sprays, which saturate the air and deliver it beneath the heating pipes at any temperature desired.

A cross-sectional elevation of a typical kiln of this type is shown on Fig. 143. The spray chambers on the sides of the kiln are 6 or 7 feet in height, from 12 to 16 inches in width, and extend the entire length of the kiln. The top of the spray chamber is open and may have a runway above it. The bottom forms a gutter which drains to the end of the kiln and thence to a well. The sides of the chambers are thoroughly waterproofed. The series of sprays which saturate the air is near the tops of the chambers. The air passes down the chamber, thence through



the baffles which separate the fine mist from the air, but allow the air to pass through in a saturated condition. These baffle plates are made of boards, which must fit tightly, since any leakage to the steam-pipe chamber would destroy the humidity control.

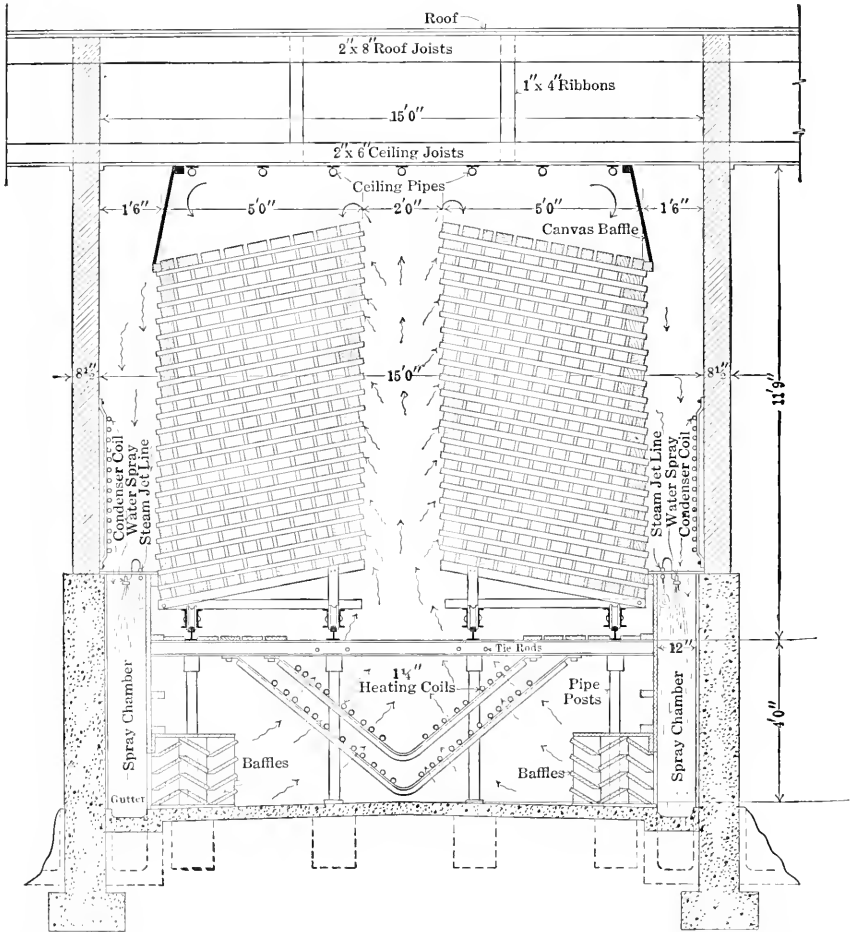

*From Bulletin 894 U. S. Department of Agriculture.*

FIG. 143.—A Cross-section of a Tiemann Humidity Water-spray Dry Kiln.

The floor under the trucks serves to prevent the hot air from the heating coils striking directly on the lower courses of boards. The floor also serves as a runway.

The method of piling recommended is shown in the figure, a flue 12 inches or more wide being left in the center. Canvas curtains are hung from the ceiling to the edge of the piles to prevent the air circulation from being "short circuited."

Condensing pipes are placed above the sprays for use at the end of the drying operation when a reduced rate of air circulation suffices. Steam sprays also are placed beneath the lumber piles for removing case-hardening. A few steam pipes may be placed along the ceiling to keep the temperature slightly above the "dew point" of the air, so that condensation on the ceiling will not take place and the water drip down on top of the lumber pile.

The temperature of the water is regulated as follows: Water from the well is pumped directly from the water mains at approximately the same pressure as the water in the valve. By means of a control lever, the mixing valve will deliver water at any desired temperature between the extremes represented by the water from the well and that from the outside main. A steam pipe set in the well permits ready control of the temperature of the well water. The building should be constructed either of wood or of hollow tile.

*Humidity-regulated Steam-spray.*—This type of kiln is in the experimental stage, having been designed at the U. S. Forest Products Laboratory. Steam is admitted into the kiln through small perforations in a steam pipe, the force of the escaping steam increasing the air circulation. The humidity is kept at the desired point by means of pipe condensers. Although excellent results are said to have been secured by this system, it is wasteful from the standpoint of steam.

*Oven or Boiling.*—The common type of progressive ventilated kiln may be converted into this type by closing all ventilators. It may be used for quick drying when the wood will stand a high temperature. This scheme sometimes is used in drying green Douglas fir and other softwoods. The kiln is tightly closed and the temperature raised above the boiling point, which rapidly removes the "free water" from the wood. Unless the pile is very open the inside does not dry uniformly. The moisture content of 1-inch lumber may be reduced from 32 per cent to 10 per cent of its dry weight in from forty to forty-three hours.

### **Superheated-Steam Kilns.**

This type is not adapted to drying many of the hardwoods and softwoods because of the darkening effect produced and the weakening of the fiber which usually follows, whether or not checking or the loosening of knots occur. It is suitable only for drying wood to a shipping-dry condition when a very quick method is desired.

The high superheat, forced draft drying method is the most rapid, but it is not used by sawmill plants. A temperature of 300° F. is maintained. Very uneven drying results may be secured because the steam

loses its superheat rapidly and the maximum drying effect is on those portions of the boards with which the heat first comes in contact. As the lumber becomes dry its temperature approaches that of the steam and there is danger of the wood being injured. The steam is usually superheated by passing it around a brick oven and forcing it into the kiln by means of a blower.

The low superheat, high velocity internal circulation kiln<sup>1</sup> differs from the one above described in that a high velocity of superheated vapor is produced within the kiln itself by means of steam jets and heating pipes. This method is still in the experimental stage, but has proved successful on a commercial scale with southern yellow pine. Green lumber has been successfully dried in twenty-four hours. Tiemann states that "it should prove particularly useful for some of the West Coast lumber, such as Douglas fir, white fir, red fir, Sitka spruce, Alaska cedar, and other spruces and firs."

### Dry-kiln Equipment.

*Doors.*—The kiln doors should be easily operated, air-tight, and made of material that affords good insulation. They often are made of wood covered with a special form of asbestos sheets. Those made entirely of wood or of double-canvas curtains are more effective than metal articulated curtains because there is less loss of heat by radiation. Wooden-framed doors either slide horizontally, Fig. 142, or swing on hinges, so that they open outward, while metal and canvas doors roll up.

Sliding wooden doors are moved by means of a dry-kiln door carrier, one form of which is shown in Fig. 142. A steel track runs the full width of the kilns and on this track the carrier travels. When not in use, the carrier is detached from the doors, the latter hanging on brackets which slope towards the kiln at an angle of 45°, so that the weight of the door tends to force it against the kiln frame. To shift a door, the carrier is moved to a point opposite it, the lever handle thrown down, which movement engages hooks in slots on the door frame and raises it 3 inches and pulls it outward about 6 inches. It is then moved along the track to a convenient point. To close the door the process is reversed, raising the lever permitting the door to again seat on the brackets.

*Trucks.*—Some form of truck is required when lumber is dried in a progressive kiln. In compartment kilns they may be dispensed with and the lumber piled on fixed supports. Trucks for flat-piling differ from those for edge-piling and those for cross-piling differ from those for end-piling. A common form for flat cross-piling is shown in Fig.

<sup>1</sup> Devised by Tiemann and others of the U. S. Forest Products Laboratory.

144*a*. The truck is from 5 to 6½ feet in length, two or three of them constituting a car. The lumber is placed flat on the truck frames, the weight of the lumber holding the trucks in position on the rail. Such a car will hold from 3000 to 4500 board feet, the amount varying with the length, the width, the thickness of the lumber, and the height of the pile. A truck for flat end-piling is shown in Fig. 144*b*. Four of these comprise a car, the space between trucks being spanned, cross-wise, by 6- by 6-inch timbers. For edge cross-piling, a type of truck shown in Fig. 144*c* and *d* is commonly used. They differ chiefly from trucks for flat

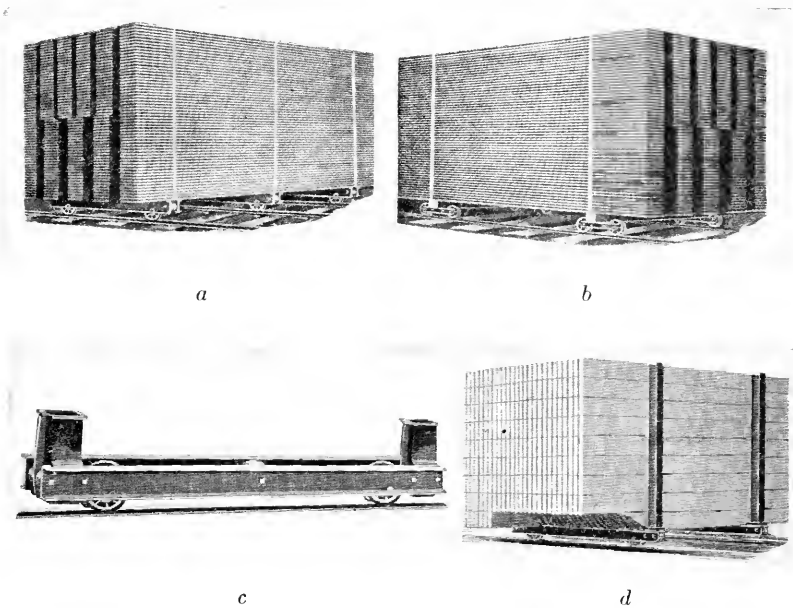

*By permission Standard Dry Kiln Co.*

FIG. 144.—Trucks used for Handling Lumber in Dry Kilns. *a*. A Common Form of Truck for Cross-piling. *b*. A Truck used for End-piling. *c* and *d*. A Truck used for edge-piling.

piling in having metal sockets, into which metal I-beams or wooden stakes are set to hold the lumber in place. Special contrivances have been devised to take up the slack in the pile as the lumber shrinks in seasoning. Unless some provision is made to overcome this the boards will slide past one another as the pile becomes loose and cause many boards to become warped and twisted. Some use a cable or rod tightly stretched between the tops of the stakes; others use a heavy coil spring with a short cable on each end which connects the tops of two opposite I-beams. Patent trucks with slack take-up devices have been put on

the market, some of which depend on the weight of the lumber, resting on auxiliary arms, to automatically bring a lateral pressure to bear on one side of the pile; others accomplish a similar result by means of cams and springs.

*Steam Traps.*—Several types of steam traps are in use to handle the water of condensation from dry kilns. One of the intermittent discharge types is shown in Fig. 145. As the water flows into the trap at *A*, it fills the space around the pot *B*, causing it to rise and close the exit at *C*. When the space around the pot becomes filled with water, the latter flows over the edges until the pot loses its buoyancy and drops upon the cone-like seat *D*. The pressure of the steam on the surface of the water then forces the latter out through the vertical hollow

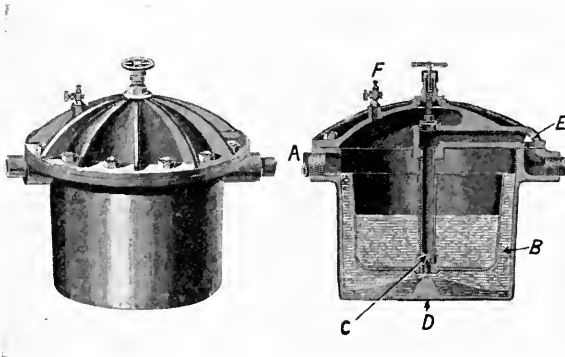

FIG. 145.—A Steam Trap for discharging Condensed Steam from a Dry Kiln Piping System. *A*. Inlet. *B*. Floating Pot. *C*. Discharge Valve. *E*. Water Outlet. *F*. Blow Cock.

cover-extension *E*. The water may be discharged directly into the open air, or into a tank, or some other receptacle if some use is to be made of it. When sufficient water has been discharged to lighten the pot, it again rises, closing the exit *C*. The action is automatic so long as there is sufficient steam pressure to cause the trap to act. The valve *F* is provided so that air may be discharged from the trap when it is started. These traps are built in several capacities, and are constructed to act at different temperatures.

The float trap, Fig. 146, a continuous-discharge type, may be substituted for the one shown in Fig. 145. This trap has a triple-valve connection *A* with an outlet pipe *B*, an inlet pipe *C*, and a float which controls the valve action. The condensed steam enters the trap through the inlet pipe *C* and when it has reached a level in the pot of from 4 to 6 inches, both the inlet and outlet are sealed so that live steam cannot escape. At this level, the float will rise sufficiently to open

the center valve, the water being forced out by the steam pressure. If the water flows in faster than it can be forced out through the center valve, it accumulates in the pot, thus raising the float higher and opening a second valve. A still greater quantity of water may be handled provided the water in the trap rises high enough to cause the float to open the third valve. As a general rule, one valve is sufficient to handle the average volume of water, the two remaining valves being held in reserve. The blow-off valve *E* is opened when the trap is first started, permitting the escape of air and thus preventing the pipes from becoming "air-bound."

One form of trap<sup>1</sup> used to return the water directly to the boilers is placed above the latter at an elevation higher than the point of dis-

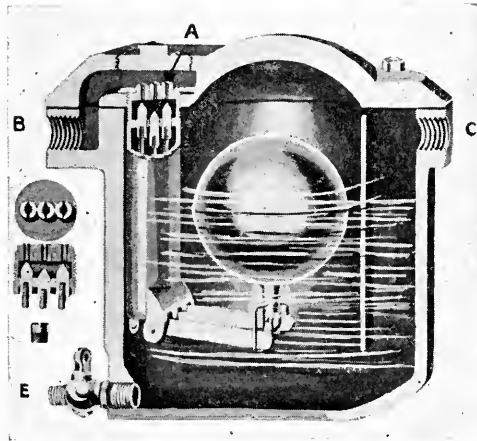

FIG. 146.—A Continuous Discharge Float Trap used to expel Condensed Water from Kiln Pipes. *A*. Triple Valve. *B*. Outlet Pipe. *C*. Inlet Pipe. *E*. Blow-off Valve which is opened when the Trap is started in order to permit the escape of Air.

charge of the water from the kiln. The drain pipe leads from the lowest point of the kiln piping, the steam pressure in the kiln pipes forcing the water of condensation up into the trap. This is made possible by means of an air-vent which permits the pressure in the trap to fall below that in the kiln pipes during the time the water is passing from the kiln to the trap. The main features of the trap consist of a floating pot, an inlet pipe, an outlet pipe, an air-vent, and a steam connection to the boilers. When the trap is filling the air-vent is open and the steam connection from the boilers is closed. As the water flows into the trap through the inlet, the pot rises until it touches

<sup>1</sup> This type is known as the "Lytton Return Trap."

the top of the trap, when the pot fills and sinks to the bottom. When at rest on the bottom the air-vent is closed and the steam connection opened and the steam pressure in the trap rises until equal to boiler pressure. The water then flows by gravity into the boilers through the outlet, until the water level falls below the top of the pot. When the latter is drained, it rises and automatically opens the air-vent and closes the steam connection to the boilers. When the steam pressure in the pot has fallen below the kiln pressure, water again flows through the inlet until the trap is full, when the emptying process is repeated.

A form of tilting trap also is used for returning the condensed steam to the boilers. An enclosed tank is placed about 4 feet above the boilers in a horizontal position, the single supporting bearing being off center. The tank is held in a horizontal position by means of a counterweight. The water, under steam pressure from the kilns, passes through an inlet pipe first into a cored chamber attached to the tank, then into a hollow trunnion which directs the water into the tank. When the latter is nearly filled the weight of the water causes it to tilt forward, and in so doing a steam valve, connected by proper piping with the boilers and the trap, is opened and live steam is delivered into the top of the tank. When the pressure in the tank reaches that in the boilers, the water flows by gravity through an outlet pipe into them. When the trap is empty it is returned to its normal position by the counterweight. During the process of filling the tank a small relief valve, automatically operated by a system of levers, permits the reduction of the steam pressure to a point below that present in the dry kilns.

*Automatic Boiler Feed Pump and Receivers.*—When a low steam pressure is used in a kiln, the water cannot be returned to the boilers by means of a return-trap system. The water is collected by gravity in a tank receiver directly connected to a steam pump which forces the water into the boilers. The steam valve on the pump is controlled by a float in the tank receiver, the speed of the pump being automatically regulated by the volume of the water of condensation.

Vacuum pumps to reduce back pressure on the engine may be installed when exhaust steam is used in the kilns. These pumps deliver the water to an open tank or well and are not designed as a boiler feed. An auxiliary steam pump must be installed to feed the water from the tank or well into the boilers.

*Instruments for Recording Temperature and Humidity.*—Temperature conditions in a kiln are determined either by the use of a standard type of thermometer or by some form of recording thermometer of which there are several on the market. The position of the thermometer in the kiln is of greater importance than the kind of instrument used.

They should be so placed that they are not directly affected by radiation from the steam pipes, or by cold air from the doors, ceilings, or walls. They also should be placed at a point where the air is in circulation.

Instruments for determining the humidity present in the kiln either may be home-made or purchased from dry kiln manufacturers. A wet-bulb and a dry-bulb thermometer and a chart from which the humidity may be determined after having read the thermometers are the essentials. A satisfactory self-reading instrument, known as the "hygro-deik," is made both in a direct-reading form and also as a self-recording instrument, which shows continuous readings of both thermometers.

### **Loading Kiln Trucks.**

There is little uniformity in piling methods used at sawmill plants. In flat-piling, which is the more common form, chimneys of various shapes are made in the piles, or the boards are staggered. Cross-piling is the common method in the progressive type of kiln, and end-piling in the compartment type.

Since "circulation is the keynote to successful drying on a commercial scale" the piles should be built with reference to the direction of the air motion in the kiln. The "path of least resistance should be in the direction of the general air movement in the kiln and this path should lie in the spaces between adjacent layers of boards."<sup>1</sup>

In a progressive kiln in which the air enters at one end and passes out the other, the general direction of the air current is in a more or less horizontal path lengthwise of the kiln. Under such conditions flat-piling is satisfactory, provided the edges of the boards are far enough apart to allow the air to sink downward at the same time it moves through the pile. If the current operates vertically, edge-piling is better than flat. This usually is true in a compartment kiln. Inclined flat-piling is a satisfactory method where the current operates in a vertical and a transverse direction.

Although the widths should be kept separate in flat-piling in order to secure more or less uniform vertical openings through the lumber for air circulation, it is seldom adhered to in practice.

Different thicknesses are usually separated for ease in stacking but often are dried in the same kiln. This is not good practice because different thicknesses require different periods of time in which to reach a given moisture content. The general procedure is to pile several lengths on the same kiln truck. This is not recommended because the ends of many boards do not meet on the stickers and tend to warp.

<sup>1</sup>See *The Kiln Drying of Lumber*, by H. D. Tiemann,



The stickers for 1-inch lumber are commonly 1 inch thick and from 1 to 2 inches in width. The same sizes often are used for 2-inch stock, although some use 1½- or 2-inch stickers for heavy material. They should be thoroughly dry and sound. Wide stickers cause uneven drying and are seldom used on that account. The number of stickers varies with the kind of lumber and the method of piling. As a rule they are spaced from 4 to 6 feet apart for softwoods and from 1½ to 3 feet apart for hardwoods, the closer spacing being for woods that have a marked tendency to warp.

The choice of flat-piling or edge-piling is based more upon the facilities for handling lumber than upon the drying principles involved. Flat-piling is generally followed in hand-stacking, while edge-stacking is in use when mechanical stackers are installed. Approximately fifty

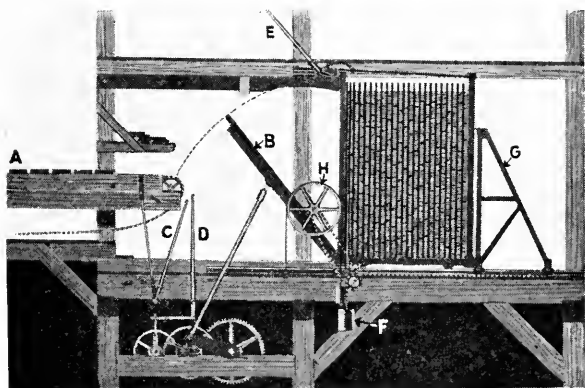

*By permission Standard Dry Kiln Co.*

FIG. 147.—Automatic Lumber Stacker for Edge-stacking on Kiln Trucks. *A.* Transfer Table. *B.* Stacker Table. *C.* Lumber Stop Lever. *D.* Table Lever. *E.* Binder Lever. *F.* Counterweights. *G.* Stake Brace. *H.* Tension-control Wheel.

courses are placed on a truck when lumber is flat piled, and from forty to fifty courses when it is edge-piled.

When trucks are loaded by hand the lumber is brought to the loading point on trams elevated to a height about equal to that of a loaded kiln truck. The stacking is done by two men, one of whom places the boards and stickers in position and the other passes the boards to him. Two men working in this manner will stack, daily, from 18,000 to 25,000 board feet.

Automatic stackers are of several types, one for edge-stacking being shown in Fig. 147. The chief features are the transfer table (*A*), the stacker table (*B*), the lumber stock lever (*C*), the table lever (*D*), the

binder lever (*E*), the counterweights (*F*), the stake brace (*G*), and the tension-control wheel (*H*). In operation, the end of the stacker table rests upon supports on the end of the transfer table. Stickers are laid at proper intervals on the stacker table, and the lumber allowed to pass from the transfer table to it. When the stacker table is full, a stop is raised by means of the lever (*C*), which prevents any more lumber from leaving the table. The table (*B*) is then raised to a vertical position by throwing the friction drive into action by means of lever (*D*). As the table reaches a vertical position the tops of the stickers raise latches, which fall into place behind the stickers and hold them in position. The table is then returned to the original position and reloaded. As each layer of lumber is placed on the car, the load is forced outward by raising the weight (*F*). When the car has been fully loaded a binding cable with a noose on each end is placed over the tops of opposite stakes, which are drawn tightly together by means of the lever (*E*).

Another type of automatic stacker, known as the cradle stacker, has a stacking table attached to a tilting frame, the base of which is mounted on three geared rockers, into which driving pinions mesh. The empty truck is run upon the tilting frame, and the frame and car then tipped about  $45^\circ$  until the stacking table comes to rest on supports at the end of the transfer chains which bring lumber from the mill. At the end of the transfer table there are two projecting arms carrying endless chains, which deliver lumber upon the stacking table. The arms are pivoted so that they may be raised as the different courses are stacked on the truck. When the kiln car is loaded the outside stakes are put in place and opposite stakes are fastened together at the top with tie-rods. The frame is then brought to its normal position and the loaded car shunted upon a transfer track. A loader of this type will stack twenty cars of 16-foot lumber in ten hours.

### Unloading Kiln Trucks.

The cars of lumber generally are unloaded soon after they leave the kiln and the boards placed in a dry shed until required to fill orders. In some cases, however, the lumber is taken directly from the dry kiln to the planing mill, often on the kiln trucks, and the lumber re-manufactured at once. This practice is more common with flooring strips than with other kinds of stock.

While this practice saves some handling, it has the disadvantage of producing a higher per cent of "degrades," because the lumber as it leaves the kiln is bone-dry and machine defects, such as chipped grain and torn grain are more frequent. If allowed to stand for a few days

under cover the lumber absorbs moisture from the atmosphere and can be worked with less loss. When lumber is stored in sheds it is graded and assorted at the time it is taken from the kiln trucks.

Lumber which is piled flat on kiln trucks is unloaded by hand, one man standing on the load and handing the boards to another on the floor level, who after grading and assorting the pieces places them on lumber buggies for transport to the dry sheds, or to the car. The stickers are placed on a separate truck and later taken to the loading end of the kiln for further use. Two men may handle from 20,000 to 40,000 board feet, daily, by this method. The unloading often is done by the stackers who devote a portion of their time to this work.

Power devices for unloading are in frequent use when the boards are edge-stacked. Several types of machines are employed. These discharge the lumber upon a transfer and assorting table where it is graded and then pulled off and placed on lumber buggies for transport to storage sheds or to other parts of the plant. In some cases, however, the product is carried on transfer chains directly to the dry sheds.

A vertical unstacker has two endless chains spaced about 6 feet apart, each equipped with a special link having a projecting lug. These chains run vertically from the floor level to the transfer table. The chain is driven by a friction drive controlled from the transfer table deck. The loaded car is spotted opposite the endless chains with the first course of boards tight against them. The car is automatically held in position by a set of counterweights, cables from which are attached to the rear end of the kiln trucks. After removing the binders at the top of the truck stakes, the endless chains are set in motion and the lug on each chain comes in contact with the lower edge of the first tier of boards and raises the tier in a vertical direction, so that the boards drop upon the transfer table. The stickers are then removed from below and the chains again started and the process repeated.

The speed of unloading is influenced by the rapidity with which the lumber is graded and taken off from the assorting chain. As a rule, at least one-half hour is required per car which gives a maximum hourly capacity of from 7000 to 8000 board feet.

### Capacity of Dry Kilns.

The drying capacity of a kiln depends on temperature, humidity, circulation, degree of dryness required in lumber, thickness of pieces, and methods of piling. In a progressive type of kiln in southern yellow pine it is customary to take out, daily, from three to four truck loads of lumber, that is, from 10,000 to 20,000 board feet. Since the average kiln will hold from fourteen to fifteen 6-foot trucks, crosswise piling,

this calls for about a seventy-hour drying period.<sup>1</sup> If the latter can be reduced, the capacity of the kiln will be increased in proportion.<sup>2</sup>

Laths are not dried in the same compartments as lumber because of the greater length of time required to properly season them. Small timbers are placed across the trucks and the piles of lath bundles are built up crib-fashion, with a 2- or 3-inch space between each. About three hundred bundles comprise one kiln truck load. From five to six days are required to dry the bundles, because the lath are tightly packed, and the circulation of air in the interior of the bundles is impeded.

#### DEPRECIATION OF LUMBER DURING THE SEASONING PROCESS

There is a depreciation in the quality and a loss in the quantity of lumber during the process of seasoning both in yards and in dry kilns due to a change in grade and to waste. This depreciation results from seasoning checks, loose knots, sap stain, warping, splits, and breakage in handling. The amount of loss is governed by the climatic conditions, method of piling, location of piles, length of time left in the pile, the methods of kiln-drying used, and the physical characteristics of the species.

#### Air-drying.

The chief factors which influence the deterioration of lumber in yard seasoning are the location of the yard, the methods of piling lumber, the climate and season of the year, and the dimensions of the stock.

Deterioration is more pronounced (*a*) when the yard site is not well drained and is so located that a good circulation of air is not present; (*b*) when piling methods are such that air circulation within the pile is impeded and rain water is permitted to reach the interior; (*c*) during seasons when the relative humidity is high; and (*d*) when thick stock is seasoned.

The effect of seasoning is shown by the following results for sugar pine:<sup>3</sup>

<sup>1</sup> In reply to a query as to the time required to dry 1-inch southern yellow pine lumber, 40 firms reported from 48 to 60 hours; 48 firms from 60 to 80 hours; 10 firms from 80 to 100 hours; and 1 firm over 100 hours. Lumber Trade Journal, Nov. 1, 1914, page 15.

<sup>2</sup> See The Kiln Drying of Lumber, H. D. Tiemann, pages 278 to 285, for graphs showing the approximate time required to dry various woods with a specified temperature and humidity.

<sup>3</sup> See The Deterioration of Lumber, by Merritt B. Pratt, Bul. No. 252, College of Agriculture, Agricultural Experiment Station, Berkeley, California, May, 1915.

TABLE III.—FALL-PILED SUGAR PINE \*

Original Grade	Thickness of Lumber, Inches	Proportion of Lumber Deteriorating in Grade, Per Cent	DETERIORATION	
			Chief Cause	Proportion of All Lumber in Pile so Affected, Per Cent
No. 1 and 2 clear . . . . .	6/4	75.5	Blue stain	52.0
No. 3 clear . . . . .	6/4	71.2	Blue stain and check	54.0
No. 1 shop . . . . .	5/4	70.6	Blue stain and check	36.0
No. 1 shop . . . . .	4/4	68.0	Blue and brown stains	62.0

\* Total amount tallied 41,182 feet b. m.

TABLE IV.—SPRING-PILED SUGAR PINE †

Original Grade	Thickness of Lumber, Inches	Proportion of Lumber Deteriorating in Grade, Per Cent	DETERIORATION	
			Chief Cause	Proportion of All Lumber in Pile so Affected, Per Cent
No. 1 shop . . . . .	6 4	41	Blue stain and check	21
No. 1 shop . . . . .	8 4	56	Blue stain and check	43
No. 2 shop . . . . .	6 4	21	Blue stain and check	15
No. 2 shop . . . . .	8 4	36	Blue stain and check	24

† Total amount tallied 51,147 feet b. m.

The data in Tables III to IV inclusive apply only to one plant and to one species of timber and, therefore, cannot be assumed to represent even the average conditions in the region in which the study was made. However, they clearly point to the fact that the deterioration in grade due to air seasoning is an important factor in determining the profits to be made from lumber manufacture.

TABLE V.—SUMMER-PILED SUGAR PINE †

Original Grade	Thickness of Lumber, Inches	Proportion of Lumber Deteriorating in Grade, Per Cent	DETERIORATION	
			Chief Cause	Proportion of All Lumber in Pile so Affected, Per Cent
No. 1 and 2 clear No. 3 clear Australian No. 1 shop	4/4	11.6	Blue stain and handling	8.7
No. 1 and 2 clear No. 3 clear Australian No. 3 shop	5/4	11.0	Blue stain and handling	6.0
No. 1 and 2 clear No. 3 clear No. 1 shop	6/4	13.2	Check Handling Blue stain Brown stain	2.8 4.2 2.6 2.0
No. 1 and 2 clear No. 3 clear Australian No. 1 shop No. 2 shop	8/4	29.7	Check Blue stain Handling	11.7 8.4 4.0

† Total amount tallied 225,156 feet b. m.

### Kiln-drying.

The losses incident to kiln-drying are due chiefly to the physical characteristics of the wood being seasoned and to the methods of drying used.

Tests made at the California mill mentioned showed that the deterioration of sugar-pine lumber properly seasoned in a dry kiln averaged from 2 to 8 per cent for 6/4-inch stock and from 5 to 12 per cent for 8/4-inch stock. The chief causes of deterioration were checks and kiln-burn. The same thicknesses of stock air-dried during the summer (the most favorable period) showed a deterioration of 13.2 per cent for 6/4-inch stock and 29.7 per cent deterioration for the 8/4-inch stock. In the fall-piled, air-dried lumber from 71.2 to 75.5 per cent of the stock

deteriorated in grade. In western yellow pine stock the deterioration was due chiefly to checks. In 4/4-inch stock, 5 per cent of the total was degraded; in 6/4-inch stock, 6 per cent; and in 8/4-inch stock, 23 per cent. Douglas fir 4/4-inch showed a deterioration of 9 per cent and 8/4-inch stock 16 per cent, due chiefly to checks and to warping.

Data secured from tests made in drying several kiln-truck loads of southern yellow pine were submitted at a dry-kiln conference held by southern lumber operators.<sup>1</sup> The results from drying 128 pieces, 1 by 12 inches by 16 feet in size, which were graded both before and after drying, were as follows: total amount of board feet put in the kiln, 2038; amount remaining after grading and trimming, 2004 board feet or 98.34 per cent of original; decrease in B and better stock, 43.18 per cent, and in No. 1 common, 24.32 per cent; increase in No. 2 common, 25.42 per cent and in No. 3 common, 3.84 per cent. Although this may not be a typical case, yet it illustrates the high degree of degrading which may occur when lumber is dried according to the common practice.

#### EFFECT OF SEASONING ON WEIGHT

Seasoning lumber effects a marked reduction in its weight. Although the reduction is greater in kiln-dried than in air-dried stock, much low-grade lumber is still air-dried because there is less depreciation in quality.

Various lumber trade associations have adopted a series of estimated standard weights for the different species which are used by the shipper in computing the amount of freight to be added to the f.o.b. mill prices. These weights are usually determined by making a large number of test weights of given grades and species and taking the averages as the standard. There is some difference in the weights for given species adopted by the different organizations, but, on the whole, there is but little discrepancy between them. The standard weights for many native species may be found in the Appendix, pages 493 to 496.

<sup>1</sup> See The Lumber Trade Journal, Feb. 1, 1915, page 24.

## CHAPTER XI

### THE RE-MANUFACTURE OF LUMBER

#### REASONS FOR RE-MANUFACTURE

THE lumber manufacturers of this country, during the early period of the industry, sold their product in the rough, either to distributors in the central markets or to independent planing-mill operators who dressed it and sold the refined product to the trade.

It was not until about 1880 that the lumber manufacturer began to re-work his rough material into the forms required by the consuming trade. Even to-day the practice is confined chiefly to softwoods used in general construction. Hardwoods are consumed mainly by the wood-using industries in the manufacture of a great variety of articles and enter into general construction only to a limited extent, because of their higher cost and the greater difficulty of working them as compared to the softwoods.

The reasons which led to the extensive introduction of planing-mill machinery as a part of the lumber-manufacturing equipment in softwood plants are:

1. The closer utilization which is possible by the re-manufacture of the rough material at the plant. There is a demand for certain finished products in relatively shorter lengths and at a higher price than can be secured for the same stock in the rough.
2. The extension of markets. Shippers of rough lumber to the chief market centers found a high degree of competition, and often were forced to make price concessions to secure orders. The manufacture of finished products enabled the lumber manufacturer to enter the rural retail yard market in which there was less competition than in the cities; in which mixed carload lots could be sold; and in which a higher per cent of the lower grades could be disposed of than was possible in central markets where the buying was for the better class of material for public or business structures.



3. A reduction in shipping weight. Weight is the basis on which the freight rates per 1000 board feet of lumber are determined, and since large quantities of lumber are sold at a delivered price it is to the shipper's interest to reduce the weight to the lowest practicable point, because the freight on all excess weight over and above the standard must be met by him. Up to about 1870 the basis of determining the shipping rate was bulk, and hence there was less incentive to reduce the weight. It is the general practice to surface all lumber, even low grades, to standard thicknesses, or to work it into standard patterns because of this reduction in weight.<sup>1</sup>

### THE RE-MANUFACTURING PLANT

The planing-mill equipment found at sawmill plants varies from a few machines for surfacing and resawing lumber to a complete plant designed to make any desired pattern of interior finish and molding and the various "novelties," such as rosettes and stair rounds. The equipment at "timber mills" usually is more simple and less extensive than at "board mills" because the chief work is surfacing or "sizing" heavy stock.

The machinery is housed in a building separate from the sawmill and, if shaft-drive is used, a separate power house is provided. When electric-drive is used, the power is secured from the central plant.

#### The Building.

The planing mill should be located so that lumber from the yards or rough dry sheds can be brought to it on a slight down grade without interfering with the movement of lumber from the sawmill or dry kilns to the drying and storage points. It also should be located so that loading tracks may be installed adjacent to it, thus requiring a minimum of trucking to take the lumber from the machines to the car.

The building often is of one-storied open-framed construction with a sheet-iron roof. Some of the plants erected within recent years have been of steel and concrete construction. Wherever practicable, it is desirable to have the side of the building in front of the machines open so that lumber may be readily brought to the machines in which

<sup>1</sup> Longleaf pine boards 1 by 12 inches in cross-section have an estimated weight, in the rough, of 3500 pounds per 1000 board feet. S 1 S or 2 S to  $\frac{1}{8}$  inch thickness the estimated weight is 2800 pounds. The reduction in weight, therefore, is 20 per cent.

it is to be worked.<sup>1</sup> The side of the building behind the machines also is preferably open and has a loading platform and a loading track paralleling it so that the pieces as they leave the machine can be loaded on buggies and taken directly to the car. However, the loading platform sometimes parallels one of the ends of the building. The width of the building should be at least triple the length of the longest pieces, except timbers, which are handled, otherwise the stock being worked will be exposed to the weather either behind or in front of the machines. As a rule, there is space provided in front of the machines for temporary storage of surplus loads of lumber, so that the minimum time is lost when one truck load has been run through the machine and a new one is being placed in position in front of the machine. A storage space behind the machine is provided so that lumber that has been worked may be left temporarily under cover until the loading crew is ready to place it in the car or until the truckers can take it to the dry shed for storage. The average planer-and-matcher is from 12 to 16 feet in length, over all, and the minimum width of a building for handling 16-foot stock is 80 feet.<sup>2</sup> The width at some plants handling standard length stock is from 100 to 200 feet, exclusive of the loading platform, which is 6 feet or more wide, and provided with a roof, which is an extension of that on the planing mill.

The length of the building is determined chiefly by the number of machines and the methods of grading and handling lumber behind the machines. Planers-and-matchers occupy a width of floor space ranging from  $8\frac{1}{2}$  to  $11\frac{1}{2}$  feet over all. In addition to this width, it is necessary to have a clear space between the machines for operators to pass back and forth. In some cases space is allowed for moving trucks between the front and rear ends of the machine. The clearance between machines is not constant at a given plant. Two machines sometimes are placed close to each other with a wide space on either side of them. Single machines may have a wide spacing depending upon whether it is necessary to truck from front to rear or vice versa. The width of floor space allowed for each medium-sized surfacing machine, where an ample allowance is made, is from 14 to 16 feet. Since there are some machines in a planing mill, such as rip saws, gang edgers, and molding machines, which do not occupy as much floor space as the surfacing machines, the average width per machine for all sorts of equipment need not be more than from 10 to 12 feet. The total length required for a 16-machine planing mill adequate to handle the output of a two-band

<sup>1</sup> The front of the machine, as the term is here used, refers to the feeding-in end. Some prefer to term the feeding-out end the front.

<sup>2</sup> This is based upon 32 feet in front of the machine, 16 feet for the machine and 32 feet behind the machine.

board mill is not more than 185 feet. This length refers to a plant in which the finished products are loaded upon lumber buggies behind the machines and trucked to the cars or sheds.

If the lumber, as it leaves the machines, drops upon an assorting table running lengthwise of the building, the length of the latter must be increased to the extent of the required length of the assorting table beyond the last machine. This varies at each plant, depending upon how the lumber is assorted. It may require from 100 to 500 feet additional length of building. Where a long assorting table is used it frequently runs through a dry storage shed, so that the lumber as it is pulled from the chain can be readily stored in pockets on either side of the assorting chain. The extra length of building required in such cases should not be charged against the planing mill, but against assorting and storage.

### The Equipment.

Machinery is required not only to surface timbers, planks, and boards on one or more sides, but also to work planks and boards into some or all of the many patterns called for by the trade; to resaw boards into thinner stock; to rip stock into narrower widths either to raise the grade or to secure narrower stock for certain patterns; to trim stock either to make it standard length or to raise the grade by cutting off the defective portions; and to manufacture fence pickets, novelties, and other special stock.

The common types of planing machinery are known as timber sizers, planers-and-matchers, and molding machines. Planing machinery used at sawmill plants usually is equipped with four cutting heads so that stock may be worked on four sides. In other wood-working establishments some of the machines may have less than four cutter heads, surfacing on one side or on two sides, only.

Modern fast-feed planers-and-matchers may be built with a profile attachment near the feeding-out end. This attachment consists of top and bottom cylinders fitted with cutter heads ground to make any pattern of molding which is desired. The advantage of using a profile attachment is that the pattern on any given-size stock may be altered by changing the profile knives, only. This enables a quick shift from one pattern to another.

The features of a modern surfacing machine are the frame which supports the working parts; the feed table; the power-driven feed rolls which feed the piece through the machine; the top and bottom cylinders carrying horizontal cutting knives; the jointer heads which carry the vertical side-cutting knives; pressure bars which hold the stock firmly

against the cylinder heads; and the chip-breakers which press against the sides of the stock just in front of the jointer heads.<sup>1</sup> In addition, there are drive pulleys and gears which actuate the various parts of the machine.

The jointer heads are placed behind the cylinder heads and opposite each other, but the top cylinder head is sometimes placed in front of the lower one, and vice versa. The number of feed rolls varies from four to eight. They are placed behind the "bed plate" which supports the stock as it enters the machine. Feeding-out rolls also may be placed near the rear of the machine, but are not found in all types.

The cylinder heads carry four or six knives. The jointer heads may carry two, four, or six knives, the two-knife head being preferred for heavy work and slow feed. The six-knife cylinder heads are used on fast-feed machines.

*Timber Sizer.*—A timber sizer is a large and heavy machine which is used to dress timbers or heavy stock to standard sizes, and it is sometimes used to make heavy factory flooring and decking. It may be used to surface at one time two pieces of dimension on two sides.

A timber sizer often is placed under the sawmill roof or within easy reach so that timbers, which are dressed green, may be worked as they pass on their way to the loading dock without entering the planing mill proper. The larger sizers will work stock from 20 to 30 inches wide, and 16, 18, or 20 inches in thickness.

The one shown in Fig. 148 is adapted for surfacing timbers on four sides and for the manufacture of heavy flooring and decking. It has feeding-rolls (*A*), and feeding-out rolls (*B*), the gearing of which is housed. These rolls are 10 inches in diameter and the feed speed is variable, being capable of adjustment to 25, 32, 42, 44, 53, or 63 linear feet per minute. The variable feed is controlled by means of the cone pulleys (*C*). The top cylinder head is shown at *D*; the bottom cylinder head at *E*; one chip-breaker support, which also serves as the housing of a jointer head, at *F*; the bed-plate at *G*; and the pressure bar at *H*. A machine of this type weighs from 23,000 to 24,500 pounds and requires a motor ranging from 50 to 115 horsepower to operate it, depending upon the maximum thickness of stock which is to be surfaced.

The output for a machine of this character depends upon the feed speed and the size of the timbers being worked. Sizers are seldom operated continuously, unless a large amount of heavy stock is being loaded out at one time.

*Planer-and-matcher.*—This type of machine is lighter than the timber sizer and is used to surface stock 2 inches or less in thickness and

<sup>1</sup>The position of the feed rolls, chip breaker and pressure bars, and top and bottom cylinders on one type of machine are shown in Fig. 148.

to manufacture flooring, shiplap, and similar products. It does not differ in essential details from the sizer, although it is a faster feed machine. When equipped with a profile attachment near the feeding-out end, a planer-and-matcher may be used to manufacture ceiling, partition, drop siding, grooved roofing, casing, base, crown moldings, and many other patterns. It is a general purpose machine for working boards and dimension, especially the former.

They are made in various sizes, usually for a maximum thickness of 6 inches, sometimes 8, and for a maximum width of 9 or 15 inches, and are built to operate at feed speeds ranging from 80 to 300 linear feet per minute, the higher speeds requiring a special type of machine

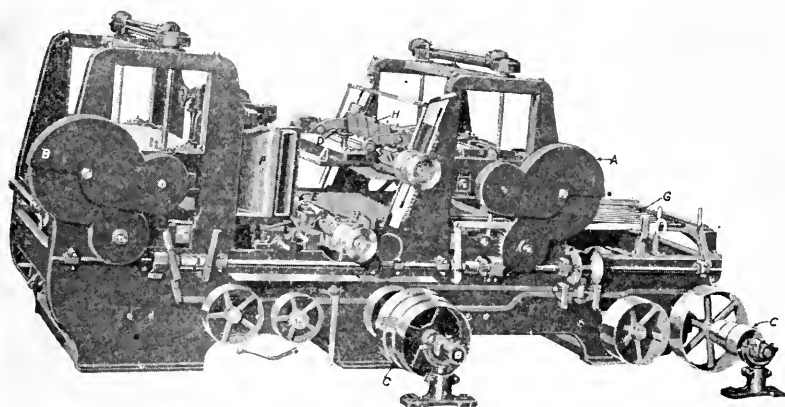

*By permission American Woodworking Machinery Co.*

FIG. 148.—A Timber Sizer. A. Feeding-in Rolls. B. Feeding-out Rolls. C. Variable-feed Cone Pulleys. D. Top Cylinder Head. E. Bottom Cylinder Head. F. A Case which encloses one of the Jointer Heads and also serves as a Chip Breaker Support. G. Bed Plate. H. Pressure Bar.

which has been developed during the last few years. The output of a fast-feed planer-and-matcher may be from 10,000 to 15,000 board feet per hour, depending upon the size of the stock and the feed speed. They require a 50 horsepower motor for the machine proper and a 15 horse-power motor for the profile attachment. Two men, a feeder and a grader, can operate a planer-and-matcher when run at average speeds.

*Molding Machine.*—This is a lighter machine than either the timber sizer or the planer-and-matcher and is used in the manufacture of the smaller sizes of molding, narrow ceiling, and in sash, door, and blind work. It does not differ in its essential parts from the planer-and-matcher, other than in the size of stock which it can handle and in the slower speeds at which stock is run.

Molding machines are built in two types, known as the inside molder and the outside molder. The chief differences between these two types are that on an inside molder the feed rolls, pressure bars, and upper cylinders are capable of independent adjustment to suit the thickness of stock being worked, while the bed is stationary. On an outside molder the feed rolls and the upper head are in a fixed position, while the entire bed carrying the side heads and bottom heads may be raised or lowered to accommodate different thicknesses of stock. For this reason the outside molder is considered to be capable of quicker adjustment and, therefore, is better adapted to frequent changes. This advantage has been overcome, largely, in the modern machines and the choice between the two types depends chiefly upon the kind of machine the operator has been accustomed to use. The outside molder is a lighter and less expensive machine than the inside molder and is made to handle maximum widths of 4 inches. Inside molders seldom are made for maximum widths less than 10 inches. The largest sizes will work stock up to 8 inches in thickness. Many machines, however, are limited to 4-, 6-, or 7-inch thickness. The feed speeds at which stock is run varies from 25 to 125 linear feet per minute, the usual speed ranging from 40 to 60 linear feet. The motors used to drive these machines range from 15 to 50 horsepower, depending upon the type of machine and the maximum size of stock that may be run. The larger sizes of molding machines may be used for any class of work to which a planer-and-matcher is adapted.

*Automatic Feed Table.*—Fast-speed planing machinery has led to the introduction of automatic feed tables, especially for use with planers-and-matchers. One type is shown in Fig. 149. It has an iron-frame feed table equipped with power-driven worm rolls *A*, which keep the stock crowded against the guide *B*, and the spiral-faced, power-driven, cone-shaped feed roller *C* which feeds the boards into the planing machine. The advantages claimed for an automatic feed table are that it enables a feeder to keep at least three or four boards on the table at all times, which gives him ample opportunity to turn over the boards or to change them end for end in order to get the highest quality out of the stock; it increases the output of the machine because there is no loss of time, such as often results with hand feeding, when there may be a gap between the ends of boards as they pass through the machine.

The boards, as they are placed on the table, are shunted sidewise and forward by the worm rolls. The forward ends strike against the plate *D* which is adjusted to within one board width of the guide *B*. The board against the guide is fed forward into the machine by the feed roller *C*, and as its end passes the plate *D* another board shifts against

the guide and in turn is fed forward against the end of the preceding one. The speed of the feed roller is such that the board is fed forward at a more rapid rate than it passes through the machine, and consequently the ends are always flush.

*Rip Saws.*—The rip-sawing machinery in a planing mill is used to resaw thin stock from thicker pieces, such as cutting box stock from 1-inch lumber or ripping pieces worked on four sides into two pieces of ceiling, bevel siding, or similar stock.

A rip saw formerly was a thin, single, circular saw against which the stock was fed by hand, a form of wooden trough serving as a guide. In modern mills, rip saws are chiefly of the vertical band-saw type and are fitted with a power-driven feed roll. The set-works are so adjusted that the thickness of cut may be any desired fractional part of an inch.

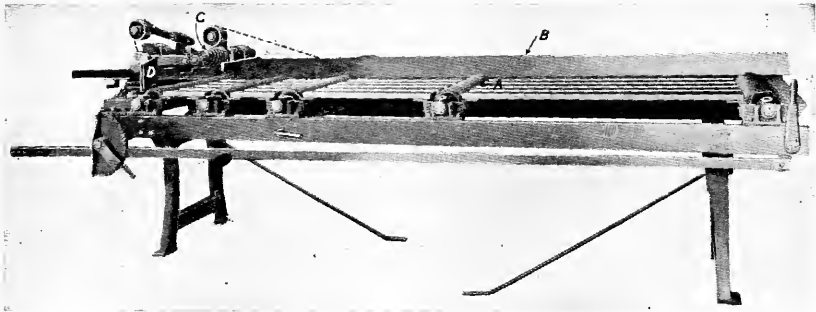

*By permission S. A. Woods Machine Co.*

FIG. 149.—An Automatic Feed Table. A. Power-driven Worm Rolls. B. Side Guide. C. Cone-shaped Feed Roll. D. Guide Plate.

The wheels range in diameter from 36 to 60 inches, often from 40 to 54 inches, and carry saws  $3\frac{1}{2}$  or  $4\frac{1}{2}$  inches in width. Some of the larger sizes have saws as wide as 6 inches. The gauge of the  $3\frac{1}{2}$ - and 4-inch saws is from 18 to 21, that for the  $4\frac{1}{2}$ - and 5-inch saws from 17 to 19, and for the 6-inch saws from 16 to 18. The speed of the saws is from 8000 to 10,000 linear feet per minute. The feed speed varies from 20 to 200 linear feet per minute. When electrically driven, a motor having 15 to 50 horsepower capacity is required. The power rip saw shown in Fig. 150 weighs 7500 pounds; occupies a floor space  $6\frac{3}{4}$  feet in width and  $4\frac{1}{8}$  feet in depth; has an extreme height of  $9\frac{1}{2}$  feet, diameter of wheels 54 inches, and saw width 6 inches. It will resaw 14- by 29-inch timbers and has a minimum feed speed of 20 linear feet and a maximum feed speed of 160 linear feet per minute.

*Re-edgers.*—Light power-feed edgers with one or more saws form part of the planing-mill equipment, and are used to rip stock to secure

narrower widths or to raise the grade. They differ from the edging machinery in the sawmill in that they only are adapted to light work.

*Cut-off Saws.*—Small swinging cut-off saws, Fig. 151, suspended from above, are installed behind the planing machines for trimming

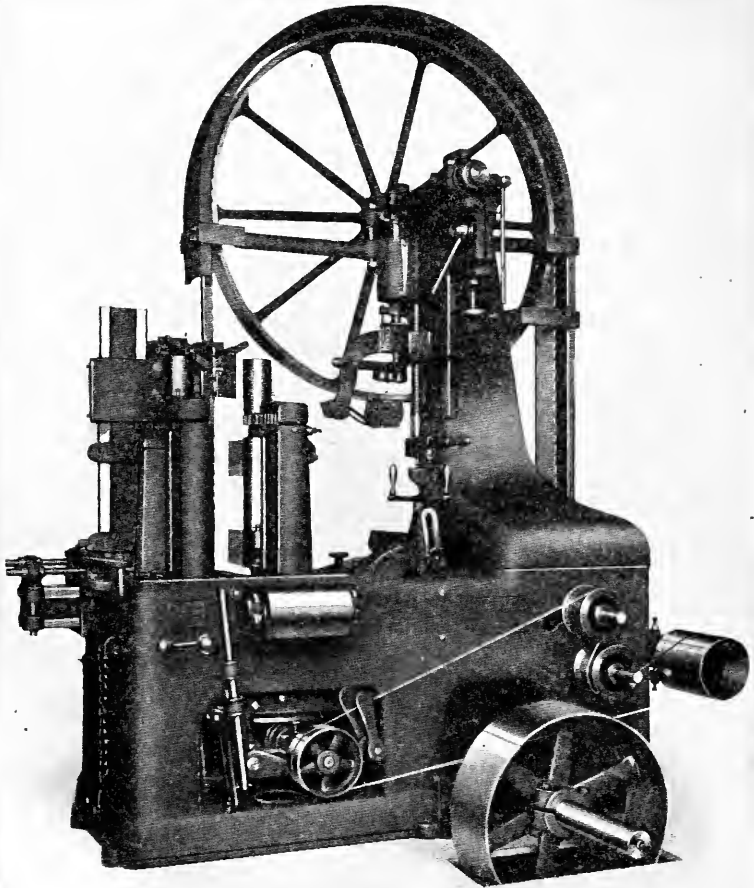

*By permission Wm. B. Mershon & Co.*

FIG. 150.—A 54-inch Vertical Resaw for Planing Mill Use.

stock when the practice is followed of grading and bundling the product as it leaves the machine. The saw is placed at the far end of a narrow table which is placed at one side of and parallel to the rear of the planing machine and has markers spaced 1 foot apart.

Where the product, as it leaves the machines, is dropped upon an assorting table for grading, a battery of trimmer saws, each saw spaced



1 foot apart, is placed above the table and all trimming is then done by one trimmer man. This method is less satisfactory than the installation of single saws behind each machine, because the most economical results are not always secured on account of the large volume of lumber passing the trimmer man. Swing cut-off saws have an 18-inch saw and, when electrically driven, require a 3 horsepower motor. When a battery of trimmer saws is employed about 1 horsepower per saw is required.

*Auxiliary Machinery.*—“Board” mills may install equipment in the planing mills to manufacture special kinds of stock for which there is a demand from the general retail trade. This equipment may comprise machinery for pointing fence pickets; wood-turning lathes for manufacturing various turned products such as stair rounds and rosettes for door and window casings, and other “novelty” stock which may be made from short material; box-shook equipment which can rip, resaw, and trim lumber; automatic machines which can nail cleats on box ends or fasten them together with corrugated strips of metal; and shook-bundling facilities. Auxiliary machinery of this character is found only in planing mills at which there is close utilization. The novelty and box departments often are operated as a separate feature of the regular planing-mill work.

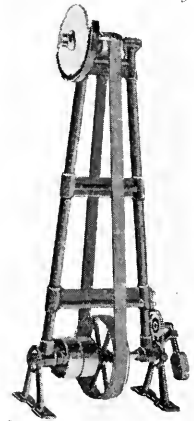

FIG. 151.—A Swing Saw of the Type used for trimming Lumber as it leaves the Planing Machine. It is suspended from Beams overhead.

#### REFUSE-HANDLING EQUIPMENT

The refuse which results from the re-manufacture of lumber in a planing mill consists chiefly of shavings which are removed from boards during the process of surfacing and working lumber to patterns. There also is a limited amount of sawdust from the rip and cut-off saws, edgings from ripped boards, and short trimmings. The volume of the shavings alone in a large plant is so great that it is absolutely necessary to remove them automatically as they are produced, otherwise they will clog up the machinery, and cover the floor with a deep layer of debris which not only hampers the work but also constitutes a great fire hazard.

The usual method of handling shavings and sawdust is to convey them, by means of an exhaust system, to the fuel house either of the planing mill or of the sawmill, or both, or to some other point where they may be burned or the shavings baled for commercial uses.

The weight of material in the form of shavings removed in surfacing lumber varies from 700 to 1400 pounds per thousand board feet, and in a planing mill which re-manufactures 100,000 board feet daily the total amount of refuse of this character alone which must be handled varies from 70,000 to 140,000 pounds or from 35 to 70 tons daily.<sup>1</sup>

The edging strips, which comprise a relatively small amount of material, are either "hogged" for fuel and taken by the exhaust system to the fuel house or hauled away on carts to some dumping ground and burned. Trimmings may be "hogged" for plant fuel, used in the manufacture of "shorts" and box-shook stock, or sold as fuel.

*The Dust-collecting System.*—The equipment used to handle the shavings and sawdust comprises a power-driven fan, Fig. 152, located

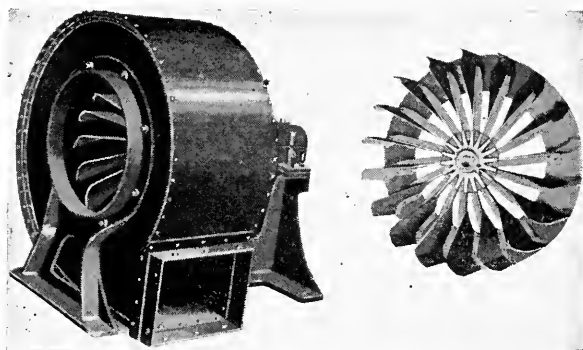

*By permission B. F. Sturtevant Co.*

FIG. 152.—Exhaust Fan and Housing of the Right-hand Bottom Horizontal Discharge Type used to move Planing Mill Refuse.

above the planing-mill floor; a main collecting pipe, overhead the planing machinery, which is connected with the fan housing, and from which smaller branch pipes pass to the cutter heads of the planing machines or other places of accumulation; a discharge pipe from the fan through which the refuse is forced to the fuel house; and a separator, or "cyclone," placed above the fuel house which serves to separate the air and the refuse, permitting the former to pass out into the atmosphere and the latter to drop into the storage bin. The refuse is carried through the branch lines and the main collecting pipe to the exhaust fan by means of suction and is discharged from the fan through the delivery pipe under pressure. A dust-collecting system for a planing mill must

<sup>1</sup> The loss in weight of southern yellow pine due to re-manufacture is 700 pounds per 1000 board feet for timbers and the common grades; finish, 800 pounds; flooring—6-inch, 1000 pounds, 4-inch, 1200 pounds, and 3-inch, 1400 pounds; hollow-backing flooring, ceiling, and drop siding further reduces their weight 100 pounds.



to 25 per cent in order that the main pipe may have ample carrying capacity.<sup>1</sup>

The main collecting pipe at points of excessive wear is made of 18-gauge galvanized sheet iron; at other places the gauge may be reduced to 19 or 20. The intakes and elbows, because of the hard usage they receive due to the amount of friction present, often are made of 16-gauge stock. The balance of the branch lines are made of 20-gauge material.

The hoods at the intakes fit closely and must be so shaped that there are no sharp angles which will retard the velocity of the air. The best designs have a "stream-line" effect so that the cutter knives tend to throw the material in the direction of the air flow and towards the entrance of the branch pipe.

The branch lines directly above the hoods are telescopic in order that the hood may be raised easily when knife adjustments are necessary. Branch pipes should enter the main line at a small angle and in the direction of the air current, otherwise eddy currents are set up in the main pipe which reduce the efficiency of the system. They should enter the side of the main pipe, in no case at an angle greater than  $45^{\circ}$ —a smaller angle is more efficient.

Elbows on branch pipes must have easy curves to keep friction at a minimum and the radius should be at least twice the diameter of the pipe. All joints of the collecting main and of the branch lines, except the telescopic joints above the hoods, are made air tight by soldering and the inside of the pipes are made as smooth as possible. A suitable gate or sliding cut-off is placed in each branch pipe, so that the pipe may be closed when the machine which it serves is not in operation. This reduces the power required to drive the fan since the volume of air which it must handle is lessened.

The amount of suction force required at the intakes depends upon the weight of the material that is to be moved. It is less, therefore, for dry shavings and sawdust than for knots and green shavings, green sawdust, and other heavy material. Provision must be made to handle the maximum weight of material which may be produced at any given intake since if the air velocity is not sufficient to pull all of the refuse up through the branch pipes the heaviest material will drop upon the machine and clog it or else fall to the floor where it must be carted away. The suction force required for a given kind of work is determined by experience and may vary from 3 to 8 inches water pressure, but usually is from 4 to 5 inches pressure.<sup>2</sup>

<sup>1</sup>Some operators claim that when all machines are not operated continuously the area may be reduced 25 per cent.

<sup>2</sup>Suction is measured in terms of the force required to raise a column of water in a U-tube a given number of inches. Thus, suction which will elevate a column

Dry shavings and sawdust require from 2500 to 3000 feet per minute air velocity in the pipes; heavy shavings and sawdust from wet wood from 3000 to 4000 feet velocity; and heavy material, such as bark, chips, and hogged refuse from 4000 to 5000 feet velocity.<sup>1</sup>

Since frictional resistance increases as the square and the power necessary to drive a fan increases as the cube of the velocity, it is essential, when power economy must be practiced, to carefully determine the velocity which is necessary for efficient operation. The static pressure at the fan must be greater than at the intakes because of the loss in pressure due to leakage and to friction both in the collecting and discharge systems. The ratio between fan and intake pressure varies in different systems because of the difference in leakage and friction due to character, size, length, and condition of pipes, and the number of elbows. It is not less than 2 or  $2\frac{1}{2}$  to 1, but in an inefficient system it may be greater.

The double-fan type is preferred for planing-mill work where the refuse from many machines must be handled because it can be placed in the center of the dust-collecting area which reduces the length of suction piping from the machines to the exhauster. The machines producing the greatest amount of refuse and which call for the maximum lifting power also may be placed nearer the exhauster than in a single-fan system, in which the fan must be placed at the end of the main collecting pipe.

The inlet pipes enter the side of the fan-housing opposite the drive pulley and the discharge pipe may be vertical, or horizontal, either from the top or the bottom of the fan, depending not only upon the direction in which the material is to be moved, but also on the manner in which the fan is belted. A bottom horizontal discharge is common in planing-mill installations because it permits a straight belt drive which is a desirable feature. The cross-sectional areas of the inlet and outlet pipes are approximately the same as the trunk-line pipe which brings refuse to the exhauster.

The size of the fan depends upon the load area of the collecting pipe, the suction required at the intake, and the velocity of air to be maintained. Several sizes of fans may do the work. When economy of power is essential, a larger fan may be used which will develop the same velocity at a lower number of revolutions per minute and with reduced

of water 3 inches is said to be equal to 3 inches water pressure. Each inch of water pressure is equal to .589 ounce air pressure per square inch.

<sup>1</sup> The minimum air velocities per second required for moving planing-mill refuse are: light material 20 feet; shavings, 40 feet; sawdust, 50 feet; knots, blocks and hogged refuse, 60 feet or more. See *Removal of Shop Refuse by Fans or Blowers* by F. R. Still, Wood-Craft, Cleveland, Ohio, Aug., 1912, pages 150-151.

power, while in cases where low first cost is of greater importance than power economy a small fan may be used.<sup>1</sup>

The discharge end of the pipe which carries refuse away from the exhaust fan is attached, at a tangent, to the upper part of a circular separator or "cyclone," placed on top of the fuel house. The cyclone is made in several shapes, some of which are shown in Fig. 153. There are several forms of interior equipment in the different types of separators, among them being spiral veins attached to the shell;

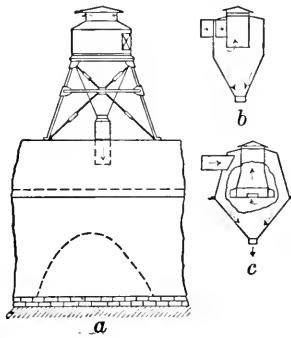

FIG. 153.—Dust Separator or Cyclone. *a*. Method of mounting the Separator on the Top of the Fuel House. *b*. A Common Form of Dust Separator. *c*. A Dust Separator having Vanes to retard the Rotary Motion of the Air.

vent, as shown in Fig. 153*b*; a simple circular vent with vanes to stop the rotary motion of the air before it escapes, as shown in Fig. 153*c*; and a simple circular vent with a disk in the lower cone, which can be raised or lowered in order to narrow the exit to the shavings vault. The air and refuse, intermingled, enter all types of separators near the top, and at a tangent, and have imparted to them a downward rotary motion. The dust and shavings, being heavier, follow the inner surface of the shell of the separator, the air traveling in a narrower circle. The vent at the base is too small to permit the volume of air and refuse to escape, and the latter, being heavier, passes out through the exit at the base of the separator, while the former passes out through the exit at the top. Since the cyclone has no working

parts it does not readily get out of order and provides a simple and inexpensive system of separation.

When it is necessary to transport refuse for long distances, the loss of energy through leakage and friction is so great that the power required to drive the fan is out of proportion to the amount of material moved. It is customary, in such cases, to relay the refuse one or more times between the source and the destination. This requires the installation of a separating system and a fan system at each relay station.

<sup>1</sup> A 35-inch fan operating against a pressure two and one-half times greater than that at the intake requires, approximately 25.95 horsepower to move 7490 cubic feet of air per minute at a velocity of 5010 feet per minute, with a load area of 172 square inches and a 5-inch hood suction. A 40-inch fan with a 26-horsepower requirement and a load area of 175 square inches will deliver 7620 cubic feet of air per minute under the same conditions.

## THE POWER EQUIPMENT

The machinery in a planing mill may be driven either by shafting and belting or by electric power. In recent years the preference has been for the latter. The power requirements are from 2 to  $3\frac{1}{2}$  horsepower for each 1000 board feet of lumber manufactured by the sawmill in a period of ten hours.<sup>1</sup>

*Shaft-and-belt Drive.*—The use of this form of drive for the machinery requires a power plant independent of the sawmill power plant because the relatively great distance between the planing mill and the sawmill power house would cause too great a loss of power in transmission. There have been cases, however, in which power has been transmitted by shafting from the main power house.

The type of steam power plant required for a planing mill does not differ from that for a sawmill, other than in the amount of power required. The building usually is of fire-proof construction, but may be of wood, and is placed alongside one end of the planing mill so that power is applied to the main drive shaft by a system of direct belting.

The boiler equipment for a planing mill handling the output of a sawmill having a daily capacity of 100,000 board feet usually comprises two 72-inch by 18-foot boilers, or their equivalent, capable of developing, approximately, 300 horsepower. The engine in modern plants is of the Corliss type, capable of developing an average load-carrying capacity of from 250 to 275 horsepower. The auxiliary power-house equipment is the same as for a sawmill power plant and consists of steam feed pumps, water heaters, and fuel conveying devices.

*Electric Drive.*—The use of electric power for driving planing-mill machinery has increased during recent years because of the many advantages it possesses over the shaft-and-belt drive. These advantages may be summarized as follows:

1. An individual power plant is not required, hence it is possible to avoid the expense of its installation, maintenance, and the labor cost of operation.

2. The cost of the added equipment which must be installed in the sawmill power plant is less than the cost of a separate steam power plant for the planing mill. The cost per horsepower installed for electrical power is greater than where shaft drive is used, but the expense of shafting, belting, and boxes and the lower power requirement when electric drive is used, usually offset this added cost per horsepower.

3. Economy in power is effected. Only those machines are operated

<sup>1</sup> See Electrically Driven Sawmills, by A. E. Hall, *Hardwood Record*, March 10, 1921, page 17.

which are required at any particular time. Since all machines are seldom run continuously only such power is consumed as is actually needed. With shaft-and-belt drive, all main shafting must be driven, even though only a small per cent of the machines are actually in use. When there are several intermediate shafts between the driving shaft and the driven machine, the loss of power is relatively great. The loss of power with electric drive is less, since intermediate shafting is unnecessary.

4. Power may be directly applied to each machine, and the latter may be placed in any desired position. Stock can thus be handled in rotation. This obviates unnecessary handling and transferring, which may block the way to or from other machines.

5. Electrical equipment occupies less space than shaft-and-belt drive equipment. This gives more head room and reduces the danger from accidents to workmen.

6. The elimination of a large part of the shafting and belting required by a shaft-and-belt drive reduces the maintenance costs for shafting, belting, and lubrication.

7. It reduces the original cost of the planing-mill structure, since expensive girder work, beams, posts, and bracing may be omitted, when a large part of the hangers, belt tighteners, and a long main shaft are eliminated.

8. It reduces the number of shut-downs which are common to a shaft-drive. Accidents to the main shafting or the main belt close down the entire plant, while a breakdown of one part of the electrical system throws out of commission a single machine only.

9. Modifications or additions to the plant can be made at a minimum cost.

10. It secures a uniform run in the machines. The speed of a given machine is not affected when additional machines are started up, which is a fault common to shaft drive if the power plant is carrying the maximum load.

11. It reduces the fire-insurance rate, since there is less danger from fires because of the reduced number of shaft boxes which may become overheated through inadequate lubrication.

The alternating current, squirrel-cage induction motor operating under a 440-volt current is used for planing-mill purposes, except where direct current only is available. The type mentioned is preferred because of its simplicity and reliability, and because the fire hazard is less, due to the absence of sparking, if the motor happens to be partially buried in shavings. Modern direct-current motors, however, are less subject to sparking than some of the earlier types.

In installing electric drive for planing-mill machinery, it is cus-



tomy to use an individual direct-connected motor for each machine which requires a relatively large amount of power, while machines such as trimming saws and grinding-room machinery, may be grouped on short shafts driven by one motor.

The motors and starters are equipped with circuit breakers and are controlled by a switch. In the squirrel-cage type of motor which develops less than 5 horsepower, a knife switch is used, while motors developing a greater power have an auto-starter or compensator, which reduces the starting speed until the motor is under headway. The electrical power required to drive a given machine varies greatly, because of the different conditions and methods of work and the difference in efficiency due to a variation in the standards of upkeep maintained in different plants. As a rule, motors should carry practically a full load to operate with the greatest efficiency since the installation of machines larger than are necessary demands more power and the first cost is greater.

The general power requirements for driving planing-mill machinery are shown in the following table. It should be understood that variations from the requirements given may be necessary, because of special conditions which must be met.

<i>Type of Machine</i>	<i>Approximate Horsepower</i>
Timber sizer, 30×20.....	85
Timber sizer, 20×16.....	50
Planer-and-matcher, 15×6.....	50-75
Planer-and-matcher, 9×6.....	50
Profile attachment.....	15
Inside molder.....	30-35
Outside molder.....	10-20
Band rip saw, 64-inch.....	50-55
Band rip saw, 44-inch.....	25
Rip saw, circular.....	5-15
Cut-off saws, 16-inch.....	3-5
3-saw gang edger.....	35
Exhaust fan, 60- to 70-inch.....	150
Filing-room machinery.....	10-15

## CHAPTER XII

### PRODUCTS OF THE LUMBER INDUSTRY

THE chief products of the lumber industry are those made by converting the log contents into some form of sawed material. However, some products are not sawed, such as hewed cross ties, split staves, shakes, poles, mining stulls, acid wood, pulp wood, and fuel wood. The rough-sawed products comprise timbers, dimension, boards, laths, and shingles. A portion of this stock is further re-manufactured into flooring, ceiling, partition, siding, casing, base, moldings, box shooks, and other finished stock.<sup>1</sup>

The output of a given plant may include only a portion of the items mentioned, since the products produced depend on the character of the manufacturing facilities; the kind, size, and quality of timber available; and the class of trade to which the individual plant finds it advantageous to sell.

Timbers are produced both from hardwoods and from softwoods, chiefly the latter. This is because timbers are used for general construction purposes and in order to get the desired size in hardwoods it often would be necessary to leave an undue amount of high-grade stock on the outside of each individual stick. The return from the sale of hardwoods cut into timbers often is less than can be secured when logs are cut into material of smaller dimensions. Hardwood timbers of the larger sizes are used chiefly for car sills and similar purposes and are cut from the centers of the higher-grade logs or from the body of low-grade logs. Softwood timbers are manufactured chiefly from Douglas fir from which stock of large dimensions can be secured. Southern yellow pine was formerly manufactured into timbers on a large scale, but the increasing value of this species and the present limited amount of stumpage suitable for the manufacture of large-sized pieces has caused a decline in the southern pine timber trade in recent years.

Boards are manufactured both from softwoods and from hardwoods and comprise the greater part of the total sawed output of the industry.

<sup>1</sup> The patterns adopted as standard by various lumber manufacturers' associations may be found in the molding books issued by them.

Lath manufacture is largely confined to softwood plants, although limited quantities of laths are made from suitable hardwoods, such as basswood, yellow poplar, and other "soft" hardwoods. The wood must be of such character that it will not split readily, will hold nails firmly, and will not discolor plaster.

Shingles are produced in small quantities at sawmill plants, but the greater part of the output is manufactured in shingle mills in the Northwest from western red cedar, a wood especially adapted for this purpose because of its durability.

Finished products such as flooring, ceiling, siding, casing, base, and molding are manufactured largely from softwoods. Hardwoods are used to some extent for this purpose, but their chief use is for the manufacture of a great variety of products by the various wood-using industries of the country.

Box shooks usually are a by-product of the manufacture of lumber, being produced from the lower grades and from "shorts." They are a product chiefly of softwood mills, but small quantities are made from certain hardwoods, such as yellow poplar, cottonwood, buckeye, and other species which have a relatively light weight and are more or less white in color. Those hardwoods which are non-odorous are preferred especially for the manufacture of containers for products which would be tainted by odorous coniferous woods.

#### SIZES OF THE SAWED PRODUCTS

The various inspection rules by which lumber is graded specify standard thicknesses, widths, and lengths. Except in the case of large timbers these sizes are expressed in terms of seasoned product, sometimes in the rough, more often in the re-manufactured form. Often they do not specify the dimensions of the rough product, but rather that when seasoned and re-worked each piece must conform to certain definite sizes.

It is not practicable, from a mechanical standpoint, to manufacture rough green lumber in strictly uniform dimensions, except in some machine such as the sash-gang, because if the carriage and the head-saw do not at all times function to the highest degree, a variation in thickness may result. Further, there is no advantage in attempting to make boards of exact sizes in the rough, since the degree of shrinkage in a given piece varies with the manner in which the board is cut, plain-sawed or quartered, and with the per cent of sapwood and heartwood present. The aim, therefore, is to cut pieces of such size in the rough green that when seasoned they will make products of standard size. In the early days, when lumber was surfaced and worked by carpenters

using hand tools, the markets called for material that would work to the implied size. With the introduction of power machinery for re-manufacturing lumber to uniform standards, a tendency arose to make scant sizes.

### Thickness.

The usual standard thickness for the better grades of 1-inch lumber S 1 S or S 2 S, both in softwoods and hardwoods, is  $\frac{13}{16}$  inch;<sup>1</sup>  $1\frac{1}{4}$ -inch lumber,  $1\frac{1}{8}$  inches;  $1\frac{1}{2}$ -inch lumber,  $1\frac{3}{8}$  inches; and 2-inch lumber,  $1\frac{3}{4}$  inches. Two-inch-dimension stock, S 1 S 1 E, usually is worked to  $1\frac{3}{8}$  inches, and heavy joists are worked green to  $1\frac{3}{4}$  inches.

The grading rules of the Southern Pine Association specify that rough 1-inch common boards and fencing shall be not less than  $\frac{7}{8}$  inch thick when dry;  $1\frac{1}{4}$ -inch and  $1\frac{1}{2}$ -inch stock not less than  $1\frac{1}{16}$  inch scant in thickness; rough 2-inch common stock not less than  $1\frac{7}{8}$  inches thick when green or less than  $1\frac{3}{4}$  inches when dry; and common timbers not more than  $\frac{1}{4}$  inch scant at any point when green. Similar deviations from the implied thickness are also found in other construction woods.<sup>2</sup> If full sizes in dressed stock are desired they are subject to special contract between buyer and seller.

Formerly, several dimension standards for a single class of product, such as flooring, were in use in a given region at mills manufacturing the same species. This custom originated during the early days of lumber manufacture when the markets available to a given territory were largely local, and these often demanded special patterns and sizes. Some mills also had standards at variance with those used by other mills in the same region in order to hold the trade of their customers, on the assumption that a buyer who purchased their product would be forced to continue to use their patterns since the output of dressed stocks from two different mills could not be used interchangeably because of the difference in matching. The variation in sizes which existed may be illustrated by southern yellow pine flooring. As late as 1887 there existed at least four different standards—namely,  $\frac{13}{16}$ -inch by  $3\frac{1}{8}$ -inch face;  $\frac{13}{16}$ -inch by  $3\frac{1}{2}$ -inch face;  $\frac{7}{8}$ -inch by  $3\frac{1}{4}$ -inch face; and  $\frac{7}{8}$ -inch by  $3\frac{3}{8}$ -inch face. Some mills surfaced on one side; some mills surfaced on two sides; and some center-matched their product. This proved a great inconvenience to customers and reacted on the industry. In 1895 a convention of yellow pine manufacturers was called for the purpose of adopting a uniform standard for flooring products. The result

<sup>1</sup> The standard of some western lumber manufacturers' associations are  $\frac{25}{32}$  inch for 1-inch lumber S 2 S.

<sup>2</sup> The standard sizes adopted or in use by the various lumber manufacturers' associations may be found in the Appendix, pages 497 to 502.

of this conference was the adoption of a standard thickness of  $\frac{37}{32}$  inch and a face of  $3\frac{1}{4}$  inches. Some mills, however, did not accept this standard, among them many operators in Texas who continued to manufacture their product  $\frac{13}{16}$  inch by  $3\frac{1}{8}$  inches. Yellow pine manufacturers, as a whole, were dissatisfied with the standard adopted in 1895. Therefore, in 1898 the specifications were changed to  $\frac{13}{16}$  inch by  $3\frac{1}{4}$  inches S 1 S, which standard is now used by the members of the Southern Pine Association. Texas mills accepted the new standard in 1902. Mills in the North Carolina pine region have never adopted the  $3\frac{1}{4}$ -inch standard, but for years have manufactured 4-inch flooring with a  $3\frac{1}{2}$ -inch face, center-matched and S 2 S.

Similar discrepancies exist in products other than flooring, due chiefly to the manner in which the markets of the industry were developed, locally, many years ago. In moldings there is a fair degree of uniformity in patterns used, but due to inaccuracies in grinding planing knives at the individual mills there exists a difference in the form of moldings which are intended to be of a given pattern and size.

Since softwood lumber cannot be seasoned and S 1 S on less than  $\frac{1}{8}$  inch, the rough, green board must be at least  $\frac{15}{16}$  inch in thickness to make a standard 1-inch product,  $\frac{13}{16}$  inch thick. If the board is to be S 2 S,  $\frac{1}{16}$  inch additional must be allowed, which requires that the thickness of the rough, green board shall be at least 1 inch full. While there is no uniformity in the practice at mills in a given region, most of them cut the higher grades slightly more than 1 inch full, and the common grades 1 inch full in thickness. Hardwoods are usually cut so that they will be full thickness when dry. Therefore, they should be at least  $\frac{1}{16}$  inch full in the green. In some cases they are cut  $\frac{3}{16}$  inch full.

### Width.

The standard widths of finished lumber are less than the implied widths. Thus in southern yellow pine, 3-inch flooring lays to a width of  $2\frac{3}{8}$  inches, 4-inch flooring to  $3\frac{1}{4}$  inches, and 6-inch "dressed and matched" to  $5\frac{1}{4}$  inches. The total width of the piece is in reality  $\frac{1}{4}$  inch greater, but since this is represented by the tongue, it does not influence the area which the piece will cover.

Boards which are not matched but which are surfaced on the edges are also scant when worked to standard size. The standard width for 4- and 6-inch stock S 4 S is  $3\frac{5}{8}$  and  $5\frac{5}{8}$  inches, and for stock from 8 to 12 inches the standard width is  $\frac{1}{2}$  inch scant.

### Length.

There is no uniform standard of lengths to which lumber is manufactured in the United States. Some softwoods, such as eastern spruce,

have been manufactured in odd-foot lengths for many years, and hardwood standard lengths have been multiples of 1 foot for a long period. The odd-foot standard was not adopted in the chief softwood producing centers, however, until about 1906, when the Yellow Pine Manufacturers' Association gave official recognition to odd lengths for mill-work. On January 24, 1906, the above association amended its existing grading rules to the extent that standard lengths for flooring, ceiling, siding, partition, casing, base, window and door jambs, except as otherwise provided, should be in multiples of 1 foot, from 10 to 20 feet inclusive.<sup>1</sup>

All lumber manufacturers' associations now recognize odd lengths for mill-work products. The retail trade, as a whole, has not yet accepted odd lengths for rough or surfaced lumber of the common grades, on the plea that customers object to the use of such material. The chief drawback to the adoption of an odd-length standard for all forms of lumber rests on the disinclination of lumber merchants to provide facilities for handling the greater number of board lengths which would have to be carried in stock, and to carry on the educational campaign necessary to convince carpenters and builders that the practice is desirable. However, some retail dealers have been handling short and odd lengths for some years and have built up an extensive trade on this basis.

There is little justification for the idea that odd lengths cannot be used satisfactorily. In 1910 the United States Forest Service made a study of the use of odd lengths in building construction and found in the several buildings examined that 35.6 per cent of the flooring strips, 53.4 per cent of the siding, 41.9 per cent of the ceiling, and 47.1 per cent of the finishing lumber were used in odd lengths by the builders, all of which had been cut, from even-length stock, into the shorter odd lengths. Of the total number of pieces tallied, 47.1 per cent were used in odd lengths.

In connection with this investigation a study also was made at several southern pine mills of: (a) the waste due to even-length manufacture both in the sawmill and planing mill; (b) the possible saving by trimming to odd lengths in the planing mill only; (c) the percentage of boards possible to manufacture to odd lengths. The unnecessary waste at the sawmill and planing mill was found to be 1.21 per cent,

<sup>1</sup>The rules for 1905 recognized even lengths of 4, 6, and 8 feet for certain classes of re-manufactured products. The general specifications stated that "the standard lengths are multiples of 2 feet, 10 to 24 feet inclusive, for boards, strips, dimension, joists, and timbers. . . . Odd and fractional lengths shall be counted as of the next higher even length." The same phraseology is in use to-day for these same products, with the exception that the minimum length is 4 feet.

and at the planing mill alone, 0.62 per cent of the total board feet tallied. A similar study on the Pacific Coast showed a total sawmill and planing-mill waste of 2.07 per cent. The per cent of odd-length boards which would be found in a sawmill output, if odd lengths were standard, was found to be 5.33 and in the planing mill 10.69, a total of 16.02 per cent in average shipments from southern pine mills.<sup>1</sup> Since more than 40 per cent of the planing-mill products entering into house construction are in odd lengths, and only 16 per cent of the average output of a mill would be placed on the market in odd lengths, there is no well justified reason, other than precedent, for neglecting to save this material.

### LUMBER PATTERNS

Lumber can be worked to any pattern desired and special designs sometimes are made in accordance with architects' specifications or with those of some wood-using industry. Since there is little or no demand for such special patterns on the part of the average consumer, a special contract exists between buyer and seller with reference to the "off-grades" which accumulate during the process of manufacture. For example, if the buyer takes only the stock which is up to grade, he must pay a premium over and above the selling price of similar-quality stock worked to some standard pattern. If this is not done the buyer, as a rule, must take, at a stated price, the entire output of a given grade of rough lumber which is machined to make the desired patterns.

The standard patterns of planing-mill products, known as moldings, are shown in "molding books," of which there are two series namely, the "5000" and the "8000," so called because the pattern numbers begin with 5000 and 8000, respectively. Each pattern has a specific form and size and a given number, by means of which the particular pattern may be identified. There has been a tendency in recent years to reduce the number of standard patterns by the elimination of those which are ornate and which, because of the many irregularities of surface, tend to collect and hold dust. The "8000" series has been adopted by softwood manufacturers, while the "5000" series is used chiefly by the sash, door, and blind factories and by city planing mills. Many patterns in both series are similar, but the "5000" series is more extensive.<sup>2</sup>

Flooring, ceiling, partition, bevel siding, drop siding, grooved roofing, dressed-and-matched, patent laths, car siding and roofing, car lining,

<sup>1</sup> American Lumberman, July 16, 1910, page 35.

<sup>2</sup> Cuts of the various moldings may be found in "The Standard Moulding Book." or similar publications issued by the various lumber manufacturers' associations.

beveled cribbing, and other products also are manufactured in sawmill planing mills. These are made in sizes, standards for which have been adopted by the different manufacturers' associations. There are no national standards in existence for these products, although many of the competing woods, especially the softwoods, are made into patterns which have minor differences only.

Flooring may be surfaced on one side only, or on both sides and scored on the back; it may or may not be center-matched; and it may or may not be hollow-backed. In spite of these variations in finish, the overall dimensions are the same for a given implied width and thickness. A hollow-back on flooring is made by the removal of a portion of the wood on the back of the strip. This is either a concave depression which is  $1\frac{3}{8}$  inches long and  $\frac{1}{8}$  inch deep at the center or a small rectangular section  $\frac{1}{8}$  inch deep and  $1\frac{1}{16}$  inches wide. The chief object sought in hollow-backing flooring is to reduce the weight of the product, although it may possess some advantage in that it allows a small air space between the floor joist and the flooring strip. When the sub-floor is not perfectly flat the hollow-back may permit the workmen to do a better job. Short hardwood flooring strips are end-matched and grooved, which permits the use of lengths that do not necessarily meet over a joist. Special machinery is required for this work.

The hollow-back on casing, base, and similar molding products is a rectangular depression  $\frac{1}{16}$  inch deep, extending to within 1 inch of each edge of the piece. The chief advantage in hollow-backing such products, in addition to the weight reduction, is that casing, especially, can be fitted better against plaster since the latter often rounds slightly outward where it joins the frame.

Mill products such as flooring, ceiling, partition, siding, casing, base, and moldings are tied in bundles of five or six pieces each, usually in even lengths. This facilitates handling and prevents the face of the pieces from being marred in handling or discolored by dirt during storage because the faces of the outside pieces are turned inward.

#### GRADES PRODUCED

The quality of lumber which may be secured from any given species of timber is not uniform in the mills of a given section because there are many factors which may influence the proportion of each grade produced.

- (a) Quality of logs. The raw material available to adjacent mills may vary greatly in quality, due to site, age, and size of the timber and the extent of the damage caused by



wind storms, and insect and fungus attacks. The quality of timber available to a given mill also varies from time to time as new areas of timber are opened up. The influence of the size and the grade of a log on the quality of lumber secured is shown graphically in Fig. 154.

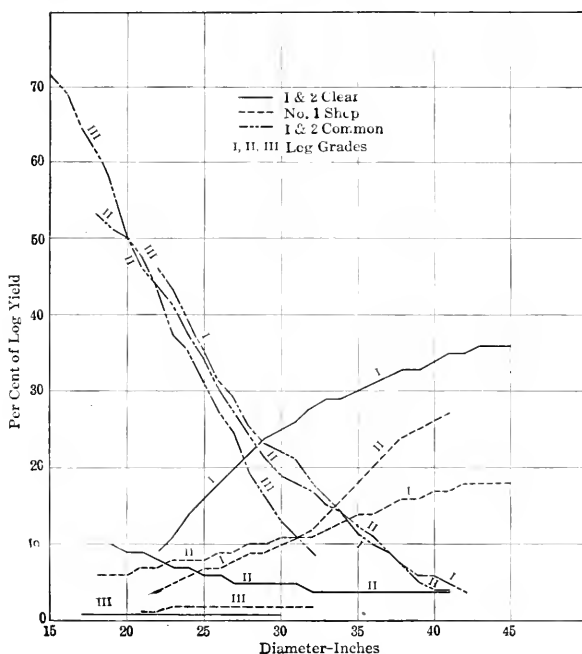

FIG. 154.—A Graphic Representation of the Influence of Log Diameters and Log Grades on the Quality of Lumber which may be sawed from Sugar Pine. Based on Data taken from a Study of the Grades of Lumber Produced from California Pine, Fir, and Cedar (Timberman, March, 1918).

- (b) Character of sawed material on which the mill specializes. Mills cutting timbers and other heavy stock do not secure as large a per cent of high-grade stock as "board" mills, since it is often necessary to leave some of the better-grade material on the timbers in order to secure the sizes required.
- (c) Methods of sawing, edging, and trimming. These factors, to a marked degree, influence the relation between the per cents of grades manufactured. Mills in which careful sawing is done and an effort is made to secure the maximum amount of the better grades, secure a higher per cent of such stock than those in which the sawing practice receives less attention. The per cent of the better grades

is also increased at those mills which insist upon careful edging. In softwood plants especially, it often is practicable to rip the wider stock into narrower widths and by so doing raise the grade of a part of the original board without affecting that of the more defective portion. Thus it may be possible to secure edge-grained flooring strips from wide boards by ripping them into two or more narrower pieces. If this practice is not followed the per cent of the better grades will be reduced. A similar increase in the better grades also may be secured by careful attention to trimming boards having defects which can be confined to limited portions of the whole, provided the board is cut into two or more pieces.<sup>1</sup>

- (d) The degree of utilization practiced. The higher the average value of a given class of raw material the closer the cubic contents of the tree and of the log are utilized. Therefore, the per cent of the better grades produced decreases as utilization becomes more intensive.<sup>2</sup>

Mill scale studies have been made by the United States Forest Service to determine the costs of production and the net yield of lumber by grades from various species. The results of a study<sup>3</sup> made on oak at a mill in the Mississippi River region in Arkansas are of particular interest because they bring out the relation between the volume of quarter-sawed and plain-sawed stock in the different grades; the relation between the amount of quartered stock produced when logs are plain-sawed as compared to quarter-sawed; and the relation between the percentage of grades produced from butt, middle, and top logs, and "sound," "sound and defective," and "all defective" logs. The lumber produced from logs included in this study was inspected and graded according to the rules of the National Hardwood Lumber Association, by an official inspector of that association and, therefore, represents commercial practice.<sup>4</sup>

The range of lumber grades produced in the various forest regions of the United States are indicated by the Tables XVI to XXXI in the Appendix. These represent averages only and are not intended to apply to any specific plant or locality.

<sup>1</sup> See *When to Rip or Trim in Grading Surfaced Softwoods*, by L. R. McCoy, *American Lumberman*, April 29, 1922, pages 1 and 40.

<sup>2</sup> The general range of grades produced in the different regions is indicated by the data given in the Appendix, pages 1484 to 1492.

<sup>3</sup> See page 488 in the Appendix.

<sup>4</sup> The results of a similar study made on Maple at a Wisconsin plant are shown in the Appendix, page 492.

## STOCKS

Data on the volume of lumber carried on hand by mills in the United States have not been compiled and published by an official agency. An examination of statistics of stocks-on-hand reported by members of various lumber manufacturers' associations indicate that the volume on January 1 of a normal year, at all mills in the United States approximates at least 20 per cent of the lumber cut during the previous year. This does not include stocks held at wholesale distributing points and at local retail yards for which no data are available. The bulk of the stocks on hand at sawmills are those found at "stock" mills which sell to the general building trade, the requirements of which are largely standardized as to sizes. The latter fact makes it possible to accumulate lumber during the period of the year when climatic conditions make milling most practicable. The general retail demand is seasonal, and since many of the lower grades in softwoods and a large per cent of all grades in hardwoods are air-seasoned, relatively large stocks must be carried in order that market requirements may be met as they arise.

Due to climatic conditions production is more or less seasonal in New England, the Lake States, the Inland Empire, and in California and a sufficient volume of stock must be manufactured during the "open" season to meet the annual demands. Cypress also is largely air-seasoned and large stocks are necessary to meet the market requirements. Hardwoods require more time for air-seasoning than softwoods and large stocks must be carried. The southern pine industry in the region west of the Mississippi River is run largely on the "stock" basis. Formerly some large mills carried as high as 25 or 30 million board feet of lumber in their yards. At the present time few mills carry more than one-half this amount except during extended periods of dull trade when the mills may continue to manufacture a larger volume of lumber than they are able to move at the moment.

On the east side of the Mississippi River there are many "order" mills which carry relatively light supplies of lumber because they cut chiefly on orders for specialized northern trade and for export. The demands of this domestic and foreign trade vary greatly, in so far as sizes and grades are concerned, and mills often are compelled to shift from domestic to export trade or vice versa in accordance with market conditions; consequently it is not practicable to accumulate large stocks.

In the Pacific Northwest there are many order mills located chiefly on or near tidewater which cut special stocks. The tendency in this region

is toward an increase in "stock" mills, owing to the growing retail trade in the middle and eastern parts of the United States.

Mills which carry heavy stocks of lumber find it necessary to maintain a fairly even ratio between the different sizes on hand, otherwise the tendency would be to accumulate a surplus of lumber which was moving slowly and create a deficit of the kind which was in demand. Since retail orders, in general, call for a variety of grades and sizes, an "unbalanced" stock would interfere seriously with the merchandising of the mill output. The "balanced stock" for a given mill may differ from time to time as market demands change, and would vary between mills in a given region based upon the class of trade sought by the individual mill. An index of what is a "balanced stock" for a given mill is determined by the sales records of the organization.

An indication of trade demands by products in southern yellow pine, based on sales aggregating more than 500 million board feet, are given in Tables VII and VIII.

TABLE VII.—DISTRIBUTION OF GRADES—SOUTHERN YELLOW PINE \*

Product	Volume	
	Board Feet	Per Cent
Timbers.....	86,289,150	16.88
B and better.....	66,274,500	13.00
No. 1 common.....	166,966,500	32.69
No. 2 common.....	146,754,000	28.72
No. 3 common.....	41,252,500	8.08
No. 4 common.....	3,212,000	0.63
	510,748,650	100.00

\* See American Lumberman, Sept. 1, 1917, page 36.

The volume and grade of stock-on-hand is determined either by periodic or by perpetual inventories and the sawing instructions are changed from time to time to secure the stock necessary to bring the supply on hand up to the balance desired. An inspector may be employed at large mills whose duty it is to see that a surplus or deficit in the various sizes does not occur. Periodic inventories often are made monthly and serve as a check on the stock-on-hand by classes, grades, and sizes and also it is used frequently as a basis for computing the monthly and annual cut and the overrun. Inventory is taken by checking up the contents of completed yard piles, and computing the contents of uncompleted piles and stock stored temporarily in sheds and in other places. Lumber is seldom tallied by grades and sizes at the

TABLE VIII.—CLASSIFICATION OF THE SALES OF SOUTHERN YELLOW PINE PRODUCTS

	Volume	
	Board Feet	Per Cent
Dimension No. 1.....	87,347,000	
Dimension No. 2.....	36,908,500	
Dimension No. 3.....	5,157,500	
	<hr/>	
	129,413,000	25.35
Small timbers.....	38,886,000	
Stringers, caps, sills, ties, specials, oil rigs, silo stock, paving block, fleet schedule.....	47,403,150	
	<hr/>	
	86,289,150	16.91
Long joists.....	1,597,000	0.31
Shorts No. 1.....	362,500	0.07
Shorts No. 2.....	2,809,500	0.55
Car material.....	35,522,500	6.96
Flooring, 1×3.....	3,328,000	0.65
Flooring, 1×4.....	28,734,000	5.63
Ceiling.....	9,100,000	1.78
Drop siding.....	11,419,000	2.25
Partition.....	1,154,000	0.30
Bevel siding.....	430,500	0.08
B and Better surfaced.....	11,252,500	2.20
C surfaced.....	1,326,000	0.26
Rough finish.....	6,410,000	1.22
Fencing No. 1.....	9,759,500	
Fencing No. 2.....	29,849,500	
Fencing No. 3.....	9,982,500	
	<hr/>	
	49,591,500	9.72
Casing and base.....	1,926,500	0.38
Jamb.....	155,000	0.03
Shiplap No. 1.....	10,342,500	
Shiplap No. 2.....	23,282,000	
Shiplap No. 3.....	5,552,000	
	<hr/>	
	39,176,500	7.67
Boards No. 1.....	12,167,000	
Boards No. 2.....	25,475,000	
Boards No. 3.....	15,383,000	
	<hr/>	
	53,025,000	10.36
Grooved roofing No. 1.....	395,500	
Grooved roofing No. 2.....	29,000	
	<hr/>	
	424,500	0.08
Miscellaneous and specials.....	36,304,000	7.12
Byrkit lath.....	637,000	0.12
	<hr/>	
Grand total.....	510,748,650	100.00
Lath No. 1.....	23,837,000 pieces	
Lath No. 2.....	2,826,000 pieces	
Molding.....	5,033,000 lineal feet	

tail of the trimmer in softwood mills, but this is a frequent practice in hardwood mills. Such a tally enables the management to keep thoroughly posted on the output of the mill, which is desirable when many species are manufactured.

A form of so-called perpetual inventory is in use at some hardwood plants and is of value in that the shipping department may determine, at short notice, the volume, dimensions, and quality of stock-on-hand and its degree of dryness.<sup>1</sup> It also eliminates the necessity of a monthly inventory.

<sup>1</sup> See The Gilbert Inventory System, by P. E. Gilbert, *American Lumberman*, June 19, 1915, pages 32 and 33, and *Southern Lumberman*, Sept. 19, 1914, pages 38 and 39.

## CHAPTER XIII

### MILL REFUSE AND ITS DISPOSAL

It is not practicable to utilize the total cubic wood content of a tree because economic conditions, in most sections, have not reached the stage where branch wood, stump wood, rough tops, and very defective logs can be profitably used. Large limbs and coarse tops are sometimes used for pulp stock, acid-wood, or firewood and stumps of conifers, which contain relatively large quantities of resin, sometimes are used for distillation purposes. However, the sawmill operator seldom is interested in utilization of this character. A portion of the tree, therefore, is not removed from the forest when a given area is logged for saw timber. There is a further loss in raw material from the merchantable portion of the tree which is taken to the sawmill to be made into sawed products because of: (a) the cylindrical shape of the bole; (b) loss of material in converting the log into boards by sawing; (c) the loss of material due to edging and trimming; (d) the loss due to defects which are eliminated in order to raise the grade of the sawed material.

The degree to which the mill refuse is utilized varies widely in a given region, even at different plants owned by the same operator, some utilizing the entire volume of refuse for some purpose, others burning large quantities in a refuse burner. Although there still is a large volume of refuse which is put to no useful purpose, methods for utilizing it are being perfected and ultimately the entire volume of the log will be put to some use, except in isolated sections where it is not possible to market by-products at a profit.

#### MERCHANTABLE VOLUME OF A TREE

The amount of merchantable material in a tree as compared to its total cubic contents is dependent on the species, the size and form of the tree, the quality of the wood, and the market conditions. Hence, it is impracticable to determine, except for specific conditions, what per cent of the total volume may be converted into sawed products. The following table shows the various products which result from the utilization of an average southern longleaf pine tree, based on present sawing practice in a band mill.

TABLE IX.—PRODUCTS OF THE AVERAGE LONGLEAF PINE TREE \*

Portion of the Tree	CUBIC VOLUME	
	Per Cent	Per Cent
Needles and twigs.....	2.25	} Top 22.35
Limbs under 2 inches.....	2.54	
Cord-wood.....	6.42	
Pulp-wood.....	4.54	
Red and rotten.....	6.60	
Red and rotten (merchantable).....	1.45	} Merchantable bole 70.56
Slabs, edgings, and trimmings.....	18.07	
Sawdust and shavings.....	17.62	
Shingles.....	0.06	
Laths.....	1.39	
Lumber and box shooks.....	31.97	
Light-wood.....	0.61	} Stump and lightwood 7.09
Stump.....	6.48	
	100.00	100.00

\* Prepared in 1920 by the "Committee on Wood Utilization and Prevention of Waste" of the National Lumber Manufacturers' Association.

This chart shows stump and light-wood content as 7.09 per cent; logs, 70.56 per cent; and tops and cull as 22.35 per cent. The amount of the total cubic volume of the tree taken to the mill in the form of logs, exclusive of cord-wood and pulp-wood, corresponds closely with data collected by the author which indicated that from 67 to 74.5 per cent of the total cubic content of a southern yellow pine tree reached the sawmill.

#### LOSS OF VOLUME IN LOG CONVERSION

Data secured at two sawmills in connection with a study of the grades produced from California pine, fir, and cedar indicated that the cubic volume of sound wood in the average log was distributed as shown in Table X, page 281.

On the basis of the above data, it requires 138 cubic feet of logs to produce 1000 board feet of lumber, with a residue consisting of 12 cubic feet of slab-wood, 16.5 cubic feet of sawdust, 11 cubic feet of edging strips, and 3.5 cubic feet of trimmings; a total of 43 cubic feet.



TABLE X.—PRODUCTS OF LOG CONVERSION \*

Mill	Boards, † Per Cent	Slabs, Per Cent	Sawdust, Per Cent	Edgings, Per Cent	Trimnings, Per Cent
No. 4.....	68.7	8.7	12.0	8.1	2.5
No. 5.....	66.8	8.3	11.1	11.3	2.5

\* See A Study of the Grades of Lumber Produced from California Pine, Fir, and Cedar, by Swift S. Berry, The Timberman, March, 1918, pages 36-37.

† Both mills used band saws. Material was sawed to a minimum length of 4 feet in both mills and to a minimum width of 3 inches in Mill No. 4 and to a minimum width of 4 inches in Mill No. 5.

A mill cutting 100,000 board feet of lumber per day would accumulate, therefore, at least 4300 solid cubic feet of refuse. This is regarded as a conservative figure since at Pacific Coast mills the amount of hogged refuse available for fuel is estimated at 100 cubic feet per 1000 board feet of lumber manufactured, which would equal 10,000 cubic feet of material per 100,000 board feet. The disparity between these two figures is not so great when one considers that the 43 cubic feet per 1000 board feet of sawed product represents solid wood and the 100 cubic feet represents "hogged" wood. The extent to which solid wood swells when hogged is not known. Sawdust, however, usually occupies twice as much space as the solid wood from which it was made and it is probable that slabs and trimmings, when hogged, increase in bulk to that extent at least. Hence, we may safely assume that if all of the mill refuse was hogged and made available for fuel purposes, it would be equal to from 75 to 100 cubic feet per 1000 board feet of lumber manufactured.

### Bark.

The bark on logs which have been brought to the sawmill rarely has any value except for fuel purposes. No account is taken of it in scaling the contents of logs to determine the volume and it is not regarded by the mill operator as a product of value. The logger peels the bark from some species of trees, such as hemlock and certain oaks, for sale as tannin material; a very limited amount of redwood bark has found a market for the manufacture of specialties; and the bark of coniferous pulp-wood has proved suitable for the manufacture of wall paper and certain other paper products.

### Sawdust.

The major part of the sawdust is made by the head-saws, followed by the sash-gang, edgers, resaws, lath mills, trimmer, and butting or

cut-off saws. The volume of sawdust produced varies with the swage of the saws and with the size of material manufactured. The width of kerf cut by the saw is an important factor since the volume of the log converted into sawdust when 1-inch stock is being manufactured is 11 per cent, when the kerf is  $\frac{1}{8}$  inch; 16 per cent, when the kerf is  $\frac{3}{16}$  inch; and 20 per cent, when the kerf is  $\frac{1}{4}$  inch. A circular saw cutting a  $\frac{1}{4}$  or  $\frac{5}{16}$  inch kerf, therefore, is much more wasteful than a band saw cutting a  $\frac{1}{8}$  or  $\frac{5}{32}$  inch kerf.<sup>1</sup>

The relation between the volume of sawed products secured from logs of given diameters when cut with a circular and with a band saw is shown in the following table:

TABLE XI.—RELATION BETWEEN THE VOLUME OF SAWED PRODUCT CUT FROM LOGS BY BAND AND CIRCULAR SAWS \*

Diameter Inside Bark at Small End of Log, Inches	Circular Saw, Bd. Ft.	Band Saw, Bd. Ft.	Diameter Inside Bark at Small End of Log, Inches	Circular Saw, Bd. Ft.	Band Saw, Bd. Ft.
5	5.5	6.5	13	7.4	8.5
6	6.0	6.6	14	7.5	8.6
7	6.4	6.6	15	7.5	8.6
8	6.7	6.8	16	7.5	8.6
9	6.8	7.3	17	7.6	8.8
10	6.8	7.5	18	7.7	9.0
11	6.9	7.8	19	7.7	9.0
12	7.2	8.2	20	7.8	9.1

\* This table shows the average board-foot yield, per cubic foot of peeled logs, which was secured from 5177 white pine logs cut with a circular saw and 767 white pine logs cut with a band saw (saw kerf not stated). The conditions under which the lumber was cut were similar and the difference in yield was due, almost wholly, to the difference in saw kerf. The lumber in both cases was marketed in a "round-edged" form. See Waste in Milling, by Louis Margolin. Report of National Conservation Congress. Senate Document No. 676, 60th Congress, 2nd Session, Washington, 1909, page 551.

### Slabs.

The slab-wood which is cut from the outside of the logs during the process of squaring up the bole is produced at the head-saws or at the sash-gang, or resaws. The volume of slab-wood depends on the form of

<sup>1</sup> A practical illustration of this is afforded by the sawing records of Minneapolis, Minnesota, sawmills. The average overrun of these mills for the years 1881 to 1888 inclusive was 9.5 per cent. In 1889, the year in which band mills were used extensively for the first time, the overrun was 18.4 per cent and in 1890 it was 19 per cent.

the log—that is, whether it approaches a true cylinder, or whether it has much taper, and on the sawing practice at the mill. The per cent of the total volume of the log converted into slabs is greater on small logs than on large ones, owing to the cylindrical form. The amount of slab-wood produced under economical sawing conditions and close utilization is between 8.25 and 8.75 per cent of the total volume of the log<sup>1</sup> and represents about 12 cubic feet of solid wood for each 1000 board feet of lumber manufactured. In ordinary sawing practice the slab-wood may be 10 per cent or more of the total log volume. Some operators roughly estimate the amount of slab-wood at from  $\frac{1}{3}$  to  $\frac{1}{2}$  cord per 1000 board feet of lumber output. This estimate is high for present sawing practice except for mills which do not utilize, closely, the short material.

### Edging Strips.

These are a product of the sawmill proper and the volume of material which goes into this form of refuse is dependent on the species, the shape of the bole, the quality of product, the narrowest and shortest pieces which are merchantable, and the skill of the edgerman. The loss is greatest in edging lumber cut from tapering boles, since a large per cent of the lumber cut is made of even widths. An exception to this may be noted in hardwoods, the grading rules for which provide for tapering boards. However, the greater part of the hardwood cut is reduced to a uniform width. Second-growth eastern white pine often is edged parallel to the bark but this work is generally done at the factory and not at the sawmill.

Since the widest board that can be secured is governed by the width of the narrow end, the flare removed from tapering boards is converted into edging strips, unless short, narrow boards can be manufactured from them.

The edging waste in softwoods often is greater than in hardwoods, because of the practice of making boards of even widths, only. This may cause the loss of an inch or more of clear stock which is removed with the waney edge of the boards. Hardwoods, on the other hand, are often edged to random widths, so that the loss is reduced. The volume of softwood logs going into this class of material represents from 8 to 11 per cent of the total even where close utilization is practiced. Short strips and those with knots or other defects are not utilized for the manufacture of other products, but long, clear strips are manufactured into moldings by some operators, and other strips of suitable size may be used for lath stock.

<sup>1</sup> See Table X, page 281.

### Trimming.

Trimming is done chiefly at the lumber trimmer and at the timber butt-saws in the sawmill, but a part of the trimmings are a product of the cut-off saws in the planing mill, where finished stock is reduced to the required lengths. In softwood manufacture, trimming losses result from the practice of trimming boards to even lengths, in multiples of 2 feet. This may result in the loss of 1 or more linear feet of merchantable stock. Hardwoods may be trimmed to odd and fractional lengths and in such cases the loss is reduced.

The accuracy with which log lengths are measured in the woods has a marked bearing on the amount of trimming waste, since if the allowance for trimming is greater than is required, the surplus stock is wasted, and if the trimming allowance is inadequate, the sawed pieces may have to be reduced to the next lowest even foot. The total volume of the log which is converted into trimmings rarely exceeds 2.5 per cent, a part of which may be utilized later for by-products, provided the practice of saving "shorts" is followed. The volume of wood going into trimmings is greatest in those mills which trim to even lengths.<sup>1</sup>

### Shavings.

This form of refuse is produced chiefly in the planing mill, but limited amounts are produced by timber sizers located in proximity to the timber-loading docks. Shavings result from dressing lumber to patterns; surfacing lumber on one or more sides; or sizing timbers and other heavy stock. The volume depends upon the patterns produced, the quantity of product which is run through the planing machines, and the dimensions of the rough stock as compared to those of the finished material. Kiln-dried longleaf finish, in the rough, has an average weight of 3400 pounds per thousand board feet. One-inch stock surfaced on one or two sides to  $\frac{1}{16}$  inch weighs 2600 pounds, which shows a reduction in weight of 800 pounds or 23.5 per cent. Assuming the average cubic volume of 1000 board feet of 1-inch stock to be  $83\frac{1}{3}$  cubic feet, the amount of shavings produced is 19.59 cubic feet, which weighs 800 pounds. Rough 1- by 12-inch air-dried common boards weigh 3500 pounds per thousand board feet, but when S 1 S or S 2 S to  $\frac{1}{8}$  inch they weigh 2800 pounds, a reduction of 20 per cent. This indicates that the solid contents converted into shavings is  $16\frac{2}{3}$  cubic feet, and weighs 700 pounds.

The per cent of the total sawmill output surfaced or worked to patterns in different mills varies within wide limits, some board mills running as high as 95 per cent of the cut through the planing mill, others

<sup>1</sup> See the results of the U. S. Forest Service study of odd lengths, page 270.

a much smaller per cent. Assuming one-fifth of the cut to be finishing grades and the remainder common grades, the average solid content of 1000 board feet of rough lumber converted into shavings would be 17.45 cubic feet for each 1000 board feet worked. Since the space occupied by shavings is equal at least to two and one-half times that of the solid wood from which they were made, the gross volume of loose shavings per 1000 board feet would be, approximately, 44 cubic feet per thousand board feet.

#### REFUSE DISPOSAL

The refuse from sawmills and planing mills is utilized in a variety of ways depending upon the plant facilities, local demands for such material, and the initiative displayed by the plant management in developing a market for products which can be made from the refuse.

#### Fuel.

Sawdust and shavings are the chief fuel used by large sawmill plants which develop their own power, not only because the boiler can be stoked mechanically, but also because a higher-priced fuel would have to be purchased and a market found for the refuse or facilities provided for burning it if it were not consumed under the boilers. As a rule, the current production of such refuse is adequate to operate the power plant when the sawmill is running, but the surplus, if any, is rarely sufficient to provide the required amount of fuel for steaming purposes when the mill is not in operation, such as at nights and during Sunday or holiday shut-downs.

The sawdust from some species is more valuable for fuel than that from some others either because of its lower moisture content or because of its resinous nature. Hardwood sawdust, as a rule, does not burn as readily as that from softwoods and among softwoods, western hemlock sawdust is inferior to that from Douglas fir, and sawdust from frozen logs has a higher water content than that from logs of the same species which are not frozen. When used alone it tends to pack on the grates and combustion is retarded. This is overcome by mixing planing-mill shavings and hogged refuse with it.

Portable sawmills rely chiefly upon slab-wood for fuel, and discard the sawdust because the furnaces seldom are of a type suitable for burning finely divided fuel. Wood in the form of slabs is not used extensively as fuel in large mills because of the expense of hand stoking and also because the constant opening and closing of the furnace doors tends to cool the boiler shell. Slab-wood is reduced, in a refuse grinder or hog,<sup>1</sup>

<sup>1</sup>See page 108 for a description of refuse grinders.

to chips and fed into the furnaces along with sawdust and shavings. The production of hogged refuse, therefore, not only aids combustion, but also enables a plant to store up a surplus of fuel for use during shut-downs. Some plants, especially on the West Coast, convert all of their surplus slab-wood, edging strips, and trimmings into hogged refuse and sell it to power-development companies for fuel, to public and other agencies for heating buildings, or else develop power which they sell to commercial concerns.

Mixed sawmill waste has a fuel value, per pound, of approximately 5000 B. T. U. and planing-mill shavings of approximately 8500 B. T. U.<sup>1</sup> These figures vary with the species from which the refuse is produced, but represent a fair average for softwoods.<sup>2</sup>

The sale of hogged refuse is based on units of 200 cubic feet of fuel which is equivalent in steam production, approximately, to 2 $\frac{1}{4}$  barrels of fuel oil. Hogged fuel at a cost of \$2.66 per unit showed a saving of 50 per cent over coal and 33 $\frac{1}{3}$  per cent over the use of fuel oil in heating school buildings in Tacoma, Washington.<sup>3</sup>

Slabs and planing-mill trimmings cut into suitable lengths for domestic fuel are in demand in the vicinity of sawmill plants. It is customary to have two or three saws on the slasher spaced the proper distance, usually 16 inches, and as the firewood stock passes along the conveyor to the refuse burner it is picked out and thrown into a chute from which it can be loaded on wagons. It was the practice, for many years, for sawmills in Minneapolis and St. Paul, Minnesota, to heat commercial buildings under contract, the sawmill providing the slab-wood and also employing the fireman. Firewood is sometimes shipped to nearby cities for fuel purposes, but the relatively high cost for freight greatly restricts the possibilities of this form of utilization of sawmill refuse.

### Lath Manufacture.

Slab-wood and edging strips, especially the former, are the chief source of lath stock at a sawmill plant. Laths are sometimes made from round wood, but this practice is rarely followed except in small portable mills which produce laths exclusively when the market demand makes it profitable. They are made in nearly all softwood "board" mills east of the Rocky Mountains. The practice is much less prevalent

<sup>1</sup> See Lumber Manufacture in the Douglas Fir Region, by H. B. Oakleaf, Lumber, Aug. 2, 1920, page 60.

<sup>2</sup> The evaporative value of hogged fuel as determined by tests in a power plant on the West Coast are given in the Appendix, page 514. The results of a test made in eastern Canada using a half-gas oven may be found in the Canada Lumberman and Woodworker, Oct. 15, 1914, page 35.

<sup>3</sup> The price quoted was that prevailing in Dec., 1920

among the Pacific Coast mills because of the restricted local demand and the high freight rates into the eastern consuming territory.

Laths are manufactured only from a limited number of hardwoods, such as yellow poplar, chestnut, buckeye, and other woods which can be readily nailed and which will not stain the plaster. They are made in lengths which are multiples of 16 inches because the standard distance between studding is 16 inches, center to center, and the lath ends must meet on a solid backing. Some 32-inch stock is produced, but the greater part is in 48-inch lengths. They are made in widths of 1 inch,  $1\frac{1}{2}$  inches, and  $1\frac{5}{8}$  inches (dry) and when green the thickness of five laths should be 2 inches. In lath manufacture, the slab-wood is cut into strips, the thickness of which is equal to the lath width. These bolts, placed on edge, are then run through a lath machine and ripped into pieces of the proper thickness.

Slab-wood for lath manufacture should have a thickness of 1 inch or more which will permit the cutting of two or more lath pieces, and should be free from rot, large knots, and other defects which will impair the strength of the piece.

In normal times the supply of lath produced in this country is adequate to meet the market demands and, with the exception of occasional intervals when market values have been unusually high, lath manufacture has not been a very profitable line for a sawmill. Board mills which sell to the general retail trade find it necessary, however, to manufacture sufficient laths to meet their customer's needs, because retail yard buyers often purchase mixed car-load lots of lumber and wish to have surplus space in the car filled with laths, thereby reducing the transportation cost. Shippers who are not equipped to furnish laths may find it more difficult to secure orders, since the retail buyer, who usually prefers to place his entire order with one shipper, will be inclined to patronize the firm which can supply all of the products desired.

The amount of material available for laths is influenced to a marked degree by the extent to which close utilization is practiced at the mill. If slab-wood is re-worked on a horizontal resaw to secure box material and other short stock, the residue left for lath stock may be very limited. Mills cutting 100,000 board feet of lumber, per shift of 10 hours, usually manufacture from 35,000 to 40,000 pieces of lath, which represents an output of from 350 to 400 pieces per thousand board feet of lumber manufactured. The average output per thousand feet log scale (Doyle) of timber sawed in a mill is, approximately, 500 pieces.

The yield of laths from round bolts of eastern spruce and balsam fir is, approximately, 3000 pieces per cord. The yield per cord from round southern yellow pine bolts, 5 inches and up in diameter, is about

2000 pieces of standard 1½-inch laths. The lath output of a sawmill, for the purposes of determining the overrun, usually is converted into board feet on the basis of 5000 pieces being equivalent to 1000 board feet of lumber.

### Shingles.

Shingles are made largely from round or split bolts but, in some regions, slab-wood and trimmings from timbers have been utilized in the manufacture of stock for local sale.

### “Shorts” and Box Stock.

The extent to which short stock is saved in the process of lumber manufacture is governed chiefly by the mill location with reference to wood-using industries and by the skill displayed by the sales organization in seeking out and developing markets for stock which does not meet the requirements, as to size, of the standard grades.

The waste of short material is greater in a timber mill than in a board mill because the class of trade which the former supplies does not utilize short stock and consequently the sales organization is not in touch with those industries which have need for small- and odd-sized material.

Many board mills in the southern pine region now save at the trimmer all strips 1 by 4 inches by 4 feet in length and up, in grades of No. 2 common and better. A few years ago many mills did not save any strips under 8 feet in length. This short stock is marketed in various forms. Many sell it with the regular yard stock, while others make a specialty of short lengths and work it into items such as wainscoting, pickets, barrel staves, heading, box-shook stock, crating, grain doors, and some other products.

A few mills have developed a market for material shorter than 4 feet which is manufactured into corner blocks, base blocks, step-ladder stock, and a variety of sizes required for novelty factories. This stock, which must be clear, is picked from the conveyor after the refuse has passed through the lath mill. Some stock also is secured from the trimmings in the planing mill. The sawmill stock is worked to size on a bolter and cut-off saw and tied in bundles and later kiln-dried. Some of it is re-worked in the planing mill for specialty stock, but the greater part of this material may be sold in the rough. The minimum sizes which were made from refuse at one southern pine mill consisted of pieces 1 by 1 by 25 inches; 1 by 1¾ by 6 inches; 1 by 4 by 17 inches; 1 by 6 by 12 inches; and 1 by 8 by 12 inches. A great number of other sizes larger than those mentioned were also manufactured. A crew of four men produced, daily, the equivalent of 4000 board feet of “short”



stock from the pickings saved from the refuse conveyor. Additional material could have been secured provided a machine for resawing short, thick slabs had been available.

### **Pulp Stock.**

Slab-wood of spruce, eastern hemlock, yellow poplar, southern yellow pine, and various other woods, is used in large quantities for pulp stock in this country, yet there is an extensive field still undeveloped because of the high cost of handling and transporting the slab-wood from the sawmill plant to the pulp mill. The growing scarcity of pulp-wood in the older producing regions is encouraging the establishment of pulp mills in close proximity to those forest regions which still have ample supplies of raw material.

### **Other Uses.**

There are many ways in which mill refuse, especially sawdust, is utilized in commerce for purposes other than those previously mentioned.<sup>1</sup> Among these uses may be mentioned stable bedding for stock and other animals; heat insulation in cars and ice houses; a cleansing element for removing grease from iron castings and other metal work and for removing dirt from furs; packing materials for many breakable articles, such as glassware, crockery, small machinery, and other apparatus; an absorbent for sweeping compounds; stuffing material for toys, such as dolls; composition flooring; burning clay products, especially fire brick; wall-paper manufacture; the manufacture of products of distillation, and many other uses.

### **Burning in Open or in Closed Refuse Burners.<sup>2</sup>**

The residue of the refuse at a sawmill plant which is not utilized for any useful purpose is conveyed to an open or enclosed refuse burner where it is burned. Some mills have found it possible to dispense with a burner because of the close utilization practiced. However, there are many mills which do not utilize all of their small material for hogged fuel, and still continue to use a burner. The cubic volume thus burned at a sawmill may vary from 10 to 19 cubic feet of solid wood for each thousand board feet of lumber manufactured. Reduced to cords on a basis of 80 cubic feet solid per cord, the amount of refuse per 1000

<sup>1</sup> The U. S. Forest Products Laboratory in a report issued in 1917 listed fifty commercial uses for sawdust and shavings. See *The West Coast Lumberman*, April 15, 1917, page 35.

<sup>2</sup> For a description of burners see pages 109 to 113.

board feet of lumber manufactured would be from one-eighth to one-fourth of a cord. The cost of burning refuse is represented by interest on the investment in the burner and conveyor, and the maintenance and operating cost. The total expense is seldom less than 10 cents per thousand board feet of lumber produced, and often exceeds this figure.

## CHAPTER XIV

### FIRE PREVENTION AND INSURANCE

SAWMILL and wood-working plants are subject to a relatively high fire hazard unless adequate steps are taken for prevention and control. A large quantity of refuse is produced which, in a dry condition, is readily inflammable and the greatest vigilance is necessary to protect the property.

The largest per cent of fires occur when workmen are not in the mill. Thus there are more fires at night than during the daytime in mills which operate a day shift only, and more at week-ends than during the early part of the week. The fire hazard bears a close relation to the cleanliness of the mill. Many fires are reported after the workmen have left the mill and before the refuse has been cleaned up.

Seasonal conditions also are an important factor in sawmill fire hazards. The records of one insurance company, specializing solely in sawmill risks, showed that two-thirds of its losses occurred during the months of February to June inclusive, which was the period of high winds.

#### FIRE CAUSES

Fires at sawmill plants are due to a variety of causes among which are the following:

1. An improperly installed or inadequately protected electric system. Electric arcs and short circuits due to the wearing off of insulation from wires or the overloading of generators may ignite dry dust.
2. Hot bearings. The timbers around boxes and shaft bearings often are coated with grease and many fires have resulted from overheated bearings which have ignited this grease and the highly inflammable dry dust which tends to accumulate on and near them.
3. Friction. Contact of belt edges with timbers, overloaded belts, wood split-pulleys which have become loose on the shaft, wood-filled clutches which slip, and other sources of friction are responsible for some fires.

4. Sparks from refuse burner. High winds sometimes carry sparks from open refuse burners into the mill or to other parts of the plant and cause the ignition of dust, grease, birds' nests, and other litter.
5. Sparks from locomotives. Switch engines, improperly screened, have started many disastrous fires.
6. Improper boiler-house construction. The fire hazard is increased when timbers are placed too near the boilers; when shavings are piled in front of an unprotected wooden-framed fuel vault; and when conveyors from the boiler house run in an unbroken unit into the sawmill.

### FIRE PREVENTION

Great stress is laid on fire prevention in the modern, efficiently administered plant.

#### **Cleanliness.**

The maintenance of a high degree of cleanliness throughout the plant involves the frequent removal of all dust from the beams of the different structures, especially in the sawmill and in the planing mill; the collection and disposal of all rubbish and refuse in and around machines and other places where it may accumulate; the frequent removal of grease from bearings; and disposal of all rubbish from the yards and other parts of the plant. Annual prizes often are offered to those foremen who keep that portion of the plant under their charge in the most orderly condition, the awarding of the prize being based upon insurance inspector's reports and upon frequent inspections by the local management.

The accumulated litter in a sawmill usually is removed at night and when necessary on Sundays. It should be done at the earliest possible moment after the close of the day's operations. Cleanings should take place during the shift period when night runs are made. Brooms are used to sweep up material in places which can be reached readily and steam or compressed-air jets are used to blow dust and sawdust from beams and from the interior of machines. Steam is preferred by some because it dampens the dust and prevents it from flying about. A steam jet also is serviceable in removing grease from bearings and other points where it may accumulate. However, compressed air when available is the form most commonly used for cleaning purposes. In either case a sufficient length of  $\frac{1}{2}$  inch hose with a pipe nozzle 3 or 4 feet long is used.

Whitewashing beams and exposed interior parts of the sawmill and planing mill is a general practice. If properly done, this prevents grease

from soaking into the timbers and renders the wood more or less fire-proof.<sup>1</sup> The whitewash may be applied either with a hand brush or by a spray pump. The hand method is preferred because the workman must remove all dust and grease before application, which often is not done when spraying apparatus is used; a thick liquid may be used with a brush, while a solution which can be sprayed on must be so thin that it does not form a real protection unless several coats are given; and when a spray is used bare spots are left, especially in corners, under beams, and in other places that are hard to reach.

The "no smoking" rule is rigidly enforced around sawmill and wood-working plants, a "dead line" inside of which smoking is not permitted under any circumstances, being established at a safe margin from the property.

### Fire-proofing Structures.

Some measures which are taken to render structures more nearly fireproof are the use of sheet-metal roofing, an asbestos or sheet-metal covering for all wood-framing in boiler houses which represent a possible fire hazard, fireproof walls between the power house and sawmill building, and self-closing, fireproof doors for the fuel vault, and for all openings between the power house and the sawmill.

## FIRE DETECTION

### Watchmen.

During the period when plants are not in operation, they are patrolled by one or more men. The customary method is to have clock stations at stated places and the watchman on his rounds punches his clock at each station, thus recording the time at which he reached the place. The clock records are removed daily by some member of the office force and serve as a check on the watchman's efficiency.

Some plants have developed their detection system to a point where central watch towers are used for the outlying portions of the plant.

The efficiency of watchmen as a control force is increased when an adequate number of fire-alarm boxes are installed, since these enable the protection force to turn in an alarm from any part of the plant. Disastrous fires have occurred when the watchman has been forced to go for a distance of several hundred feet to turn in an alarm.

<sup>1</sup>The following whitewash formula has been approved by the Lumberman's Underwriting Alliance of Kansas City, Missouri:

Slack one-half bushel of lime in boiling water, keeping it covered during process.

Strain the solution and add 1 peck salt dissolved in warm water, 3 pounds ground rice boiled to a thin paste,  $\frac{1}{2}$  pound Spanish whiting (powdered), 1 pound clear glue dissolved in warm water. Mix well together and allow mixture to stand for several days. Apply hot with a painter's whitewash brush.

## FIRE CONTROL

The equipment used for fire control ranges from water buckets to a modern fire-department system. The fire-fighting facilities are seldom the same at any two plants, some maintaining a more efficient fire-fighting organization than others.

**Water Barrels and Buckets.**

Water barrels and buckets, distributed throughout the lumber yards, sheds, and other buildings and along the tramways, comprise one of the simplest forms of fire-fighting equipment used. The barrels may be the ordinary wood or metal ones or they may be of some special metal type constructed in the mill machine shop. They often are given a coat of whitewash to make them more visible at night as well as to preserve them. Large stenciled numbers placed on the barrels aid the inspector in reporting those that require attention. Barrels must be inspected and refilled at frequent intervals, since the water will evaporate rapidly during hot weather.

In cold weather the water must be treated with some non-freezing solution. Some plants also require watchmen on their rounds to stir the barrel contents in order to prevent them from freezing.

The following table shows the temperature F. at which water will freeze when calcium chloride or sodium chloride is added to the water:<sup>1</sup>

Quantity of Chemical per Gallon of Water.  Pounds	Temperature Above which Water Will Not Freeze When Calcium Chloride is used.  Degrees	Temperature F. Above which Water Will Not Freeze When Sodium Chloride is used.  Degrees
$\frac{1}{2}$	+29	+29
1	+27	+18
$1\frac{1}{4}$	+25	+15
$1\frac{1}{2}$	+23	+12
$1\frac{3}{4}$	+21	+ 9
2	+18	+ 6
$2\frac{1}{4}$	+14	+ 3
$2\frac{1}{2}$	+ 3	- 1
3	- 8	- 3
$3\frac{1}{2}$	-11	- 8
4	-19	*
$4\frac{1}{2}$	-29	
5	-44	
$5\frac{1}{2}$	-50	

\* A sodium-chloride solution is saturated when  $3\frac{1}{2}$  pounds are added to 1 gallon of water.

<sup>1</sup> The inside of the barrels should be painted with asphaltum paint or brewer's varnish to prevent warping.

Another solution used by some operators is as follows: To one barrel of hot water add 6 pints of salt, 1 pint of muriatic acid, and 1 pint of Lewis lye. This is said to be effective for a temperature of  $-54^{\circ}$  F.

The tendency of workmen and others to pilfer water buckets has led to the development of various devices to prevent the loss of this class of equipment. A cone-shaped galvanized-iron bucket is now in common use. The advantages of this type are that the bucket is of little service for ordinary purposes and is not on general sale at stores. Petty theft is prevented, to some degree, by hanging the bucket above the barrel on a light frame which can be readily broken in case the bucket is required for fire purposes. Other schemes are to paint the buckets a distinct color and to number them with large stencil letters.

### **Fire Retardents.**

Fires on greasy wood or in oils rarely can be extinguished by the use of water since liquids spread the burning oil. It is customary to have boxes of common salt or sand and a scoop placed near such hazards for use in case of fire. Salt is regarded as being fully as effective as sand and is more satisfactory because of the absence of grit, which will injure the bearings.

### **Chemical Extinguishers.**

The use of chemical extinguishers is not universal at sawmill and wood-working plants; however, they are found at many operations, placed at strategic points in the various buildings.

### **Water Mains and Hydrants.**

Every plant has a water-main system and hydrants so distributed throughout the plant that every part of the property may be reached readily with a hose line. The system should constitute a closed circuit without dead ends, and the mains should be at least 6 inches in diameter, preferably 8, and placed far enough below the ground level so that they will not freeze or be damaged by the heat from fires.

The hydrants should be of the two-way type and placed at least 50 feet distant from the nearest combustible material. Hydrant openings should be uniform with those of the city fire department or of other auxiliary equipment which may be called in to aid in fire fighting, so that the hose of other departments will be interchangeable with that of the lumber plant.

Where possible, the water mains of the plant should be connected

with the city supply or to some adjoining mill system in order that an auxiliary water supply may be available in case of the failure of the mill pressure system. Several cut-off valves are placed in the water-main system in order that one portion of it may be cut out in case a pipe breaks or added pressure is needed at some particular point. The cut-off valves should be at least 75 feet, preferably 100 feet, from the buildings.

Hose houses, preferably of fireproof construction, containing from 350 to 500 feet of hose are located at strategic points where they will not be endangered by any fire which may occur. The hose with nozzle attached is placed on a suitable rack within the hose house and one end is connected with the hydrant ready for instant use.

Vertical water pipes are provided at several points in the main buildings and are equipped with  $1\frac{1}{2}$ -inch attached hose and a nozzle. The hose is kept in a rack or frame from which it can be instantly removed. "Niagaras" or large revolving nozzles are sometimes placed where they control the area occupied by the yards and the important buildings. "Niagaras" are mounted on an elevated platform and enable a fire-fighting crew to concentrate a large volume of water upon any spot within range.

Hand-drawn hose reels equipped with 500 feet of hose and with nozzles often are located at accessible points near the sawmill and planing mill. They are housed in wooden or fireproof structures and provide equipment for those hydrants which are not permanently fitted with a hose.

Both rubber-lined and unlined linen hose are used. Hose for outside use is usually  $2\frac{1}{2}$  inches in diameter, and that for interior use is often  $1\frac{1}{2}$  inches. The unlined linen hose does not rot so readily as the rubber-lined and also is lighter to handle, but it offers greater frictional resistance than rubber-lined hose, so that its efficiency is less. The standard water flow through a smooth rubber-lined hose is 250 gallons per minute at 80 pounds pressure at the hydrant. Smooth, rubber-lined hose will cause a pressure loss, through friction, of approximately 14 per cent for each 100 feet of hose, while the frictional loss with other hose may be 25 per cent or more. Hose deteriorates rapidly unless kept in a thoroughly dry condition. Even then it may wear at creases or other points. Therefore, it should be tested at frequent intervals at a working pressure of 100 pounds, in order that it may not fail at a critical time.

The type of hose nozzle used for general work is the standard round fire nozzle. These are of little value, however, for fighting fires in lumber piles, because the water is hurled back on striking the lumber and only a small portion of it enters the pile. A flat nozzle, which can be inserted in the pile openings, is the preferred type for this purpose.



### **Auxiliary Equipment.**

Various classes of auxiliary equipment are often provided for fire fighting. These include ladders, asbestos or some other type of shields for the protection of fire fighters from heat, and tool boxes containing such extra tools as may be needed. This equipment is placed at accessible points and so fixed that it will not be removed for any but fire-fighting purposes.

### **Fire Pumps.**

A pump for fire service should be strongly built with all movable parts made from rust-proof material, otherwise they are liable to fail when heavy demands are made upon them.

The standard fire pump is the so-called duplex underwriter's fire pump which is built especially for fire service, although there are other types of specially designed pumps in use. The usual types have a water capacity of from 750 to 1500 gallons per minute. They are governor-controlled and when operating at a slow speed they maintain an even pressure in the water mains at all times. They usually are operated continuously since only by so doing is there any assurance that they are in working condition at all times. As a rule, two or more of such pumps are installed at different points in order that one pump may always be ready for action. One pump may be located in the boiler room, but safety requires that the other shall be placed in a fireproof structure at a safe distance from all buildings.

The normal pressure carried in the water mains is from 40 to 50 pounds, which is increased to 100 pounds or more in case of fire.

Two sources of steam supply usually are provided: one, the main power plant which is utilized when practicable; the other an independent boiler equipment which may be used in case the main power house is destroyed or is out of commission for any reason.

### **Water Tanks.**

All large plants have elevated water tanks that are used for a general plant water supply and which also may augment the pumping system in case of fire. These must be elevated above the highest part of any plant building. Special tanks are provided for the operation of a sprinkler system when one has been installed.

The capacities of tanks vary with the general plant needs and range from 12,000 to 100,000 gallons. Tanks are supplied with water by the fire or other pumps, depending upon the facilities at the specific plant.

Water is secured from deep wells if it is used for drinking as well

as for other purposes. During the progress of a fire the water is pumped directly from the log pond or from some stream.

### Steam Jets.

Fuel houses and dry kilns are equipped with steam jets, with outside valve control, which can be used to flood the compartments in case of fire. The control valves are placed at some distance from the buildings so that they can be operated with safety.

### Sprinkler System.

Many sawmill and wood-working plant buildings are now equipped with some form of sprinkler system, usually of the automatic type.

Sprinkler heads, with a  $\frac{1}{2}$  inch orifice, are placed under the floors or ceilings in the ratio of from 80 to 100 square feet of ceiling surface per sprinkler head. These heads are closed by a valve held to its seat by an arrangement of levers held in position by fusible solder. The degree of heat necessary to melt the fusible solder on heads that are placed in sawmills, sheds, and other buildings, where there is no high artificial heat is about  $110^{\circ}$  F. In power houses and places where there is a constant high temperature the melting point of the solder must be high enough, sometimes  $300^{\circ}$  F., so that the valves will not open except when the heat is higher than normal.

The various sprinkler heads are connected with a series of water pipes, pressure for which is obtained from the water mains of the plant or from the city water supply. A special tank used solely for the sprinkler system also is provided for use in case the regular water supply fails.

In regions where freezing temperatures occur, the piping system is kept filled with compressed air which holds back the water from the pipes until a head opens. An automatic bell-alarm system gives warning when any given unit is in action.

Automatic sprinkler systems have proven effective in controlling interior fires, especially in enclosed buildings, when they start in the vicinity of a sprinkler head. They have not always been successful in controlling fires which start on the exterior of sawmill buildings, since the fire gains too great headway before there is sufficient heat in the interior to cause the sprinkler heads to open. Insurance companies, however, recognize the existence of a lower fire hazard, when an automatic sprinkler system is installed, by making a marked reduction in the premiums charged on buildings so protected. It is claimed that the cost of installation of a sprinkler system at a sawmill plant may be recovered in from four to seven years, due to the lower insurance premiums.

### Fire Companies.

There is no standard practice in the lumber industry with reference to the maintenance of a properly trained fire-fighting force. Some plants have fully organized and well-trained companies of fire fighters and, in addition, have frequent fire drills to acquaint the remainder of the workmen with their duties in case of fire. Other plants have no fire organization and do not train the workmen in the use of fire-fighting equipment.

In many mills a skeleton organization is maintained with definite men in charge, the workmen being given enough training in the location and use of equipment to enable them to handle it intelligently in case of fire. Each employee has a fire station assigned to him and is expected to report at that place whenever a fire signal is given. Plants located near cities maintaining paid fire departments may rely upon their assistance but facilities must be provided for coping with fires until the city department arrives.

## FIRE INSURANCE

Indemnity for fire losses in the lumber industry is secured through the purchase of insurance from stock, mutual, or mutual-underwriting insurance companies or associations, or in some cases by the creation of a reserve fund for self-insurance. These forms of insurance do not differ in essentials from similar insurance offered in other industries.

Many firms carry more than one form of insurance. On the average about one-half of the total is carried in stock-company insurance and the remainder in some other form. The division of insurance by classes in one section of the country, with a group of mills manufacturing a given class of timber and having similar risks was stock 51, mutual  $7\frac{1}{2}$ , mutual underwriting  $39\frac{1}{4}$ , and self-insurance  $2\frac{1}{4}$  per cent.

### Stock-company Insurance.

This form of insurance, offered by domestic and foreign incorporated fire insurance companies, is carried to some extent by the larger lumber-manufacturing plants. Its cost is higher than mutual insurance, since the stock companies are organized for profit and their operating expenses both for solicitors' and brokers' commissions and other items often are nearly double the cost for mutual insurance. The chief incentive for the establishment of mutual companies was the high rates charged for this class of insurance.

### Mutual Insurance.

This form of insurance, sometimes called inter-insurance, is a popular form not only in the lumber industry but also among certain

other large industries. All mutual insurance societies are based largely upon the general principles established in 1881 by an association called the Individual Underwriters of New York. Mutual insurance societies differ from stock insurance companies chiefly in the following particulars:

1. No contracts are written for the public.
2. The association is not operated for profit.
3. The chief object is protection of members in case of fire loss.

The association is run by an attorney-in-fact and manager under the supervision of an advisory committee chosen from among the members. It is a corporation composed of members who, in joining, sign articles of membership and agreement wherein and whereby they obligate themselves to protect and indemnify each other against loss or damage from fire or other specified agencies. No member is accepted unless his financial standing and the character of the risk are investigated and approved.

The premiums paid by members of mutual insurance associations in the lumber trade are lower than stock-company rates for several reasons.

1. The policy holders are also the stock holders, and since the profits, if any, are returned to policy holders, there is no incentive for high rates.

2. The total management expense of many mutuals is limited to 25 per cent of the premiums, while the expenditures of stock companies often absorb a much higher per cent.

3. The fire-loss ratio in a lumber mutual is lower than in a stock company because only high-class properties are insured in which the "moral hazard" is low.

4. The policy holders in a mutual pay only for the risks in their class and do not have to help carry a general rate for the more hazardous groups. The plants are widely separated and are somewhat isolated so that they are free from exposure to hazards outside of the plant itself.

In mutual insurance each policy holder, in addition to paying the premiums, assumes a limited liability, usually restricted to a sum three times the annual premium paid. If annual premiums are insufficient to pay losses, each member agrees to pay his proportionate assumed liability. Premiums usually have been ample to meet all expenses of well-managed mutual insurance associations.

### **Mutual-underwriting.**

This is a form of insurance found to some extent in the lumber industry, among manufacturers, wholesalers, and retailers, although each group has its own associations. The underlying idea of this class of insurance is that each one who enters the association underwrites

the insurance on each of his associates in proportion to the amount of the policy he carries.

The association is conducted, by a manager, at a very low expense, and since there are a relatively large number of member mills it furnishes cheap insurance. Prospective members are selected by the manager and the names submitted to the active members for approval, one dissenting vote usually causing the rejection of the proposed member. In an insurance association of this character it is customary to admit only those mills which have an excellent rating from the standpoint, both of moral and physical hazards. The names of all members are placed upon every policy issued. Inspections are frequent and rigid and the individual plants must be maintained at a specified standard of cleanliness. The arrangement of the plant, its fire-prevention policy and fire-control facilities are also closely examined.

### **Self-insurance.**

Some large lumber-manufacturing concerns owning several plants which are more or less widely separated and not subject to special fire hazards carry a portion of their own insurance—i.e., they put into a reserve fund a part of the premiums they would have to pay for insurance and reimburse themselves for their own fire losses from this fund.

### PLANT APPRAISAL

The basis for the settlement of insurance where the loss is total or partial rests upon the value of the property destroyed. If the property has not been appraised previous to the fire, the only basis for determining values are the guesses of the owner and of the insurance adjustor, which may vary within wide limits. Many mills anticipate this possible trouble and annoyance by having an appraisal made of the property, while it is intact, by public appraisers whose statements of value are accepted by insurance companies as evidence of the replacement value of the property at the time the report was made. Such appraisals list all property by items so that losses can be readily computed.

Insurance policies on sawmill and other wood-working plants have a co-insurance clause requiring the property to be insured to 80 per cent of its total value. Failure to do this obligates the owner to share the loss with the insurance company in proportion to the ratio which the actual insurance carried bears to the 80 per cent value.

### LUMBER VALUES

The volume and the value of the lumber products at a sawmill vary with the market demands and with the existing operating conditions.

When the market demands are brisk shipments may exceed production, thus reducing the amount carried on hand. Special demands for certain grades may also deplete them and at the same time cause an accumulation of other grades, the sale of which is temporarily slow. Sawmill plants in some regions do not operate during the winter season although sales are made throughout the year. Such plants accumulate stocks during the summer months which are reduced during the winter.

It is customary to shift, at monthly inventory time, the volume of insurance carried, so as to cover the value of stock on hand, since there is no benefit gained by insuring more lumber than is on hand, neither is it desirable to allow a low insured value to stand when stocks have accumulated and higher values exist.

Some plants use a "perpetual" inventory scheme whereby the amount of stock on hand may be determined at any time by an examination of office records.<sup>1</sup> This system is used chiefly at hardwood plants, which may have many more species on hand than are found at a softwood plant.

The question of grades is more important than formerly, since the principle is now recognized that the basis of settlement for fire loss is the "replacement" value of the lumber and not its "cost value."<sup>2</sup>

<sup>1</sup> See page 276.

<sup>2</sup> See the "Mitchell *vs.* St. Paul Fire Insurance Company" decision of the Michigan Supreme Court in 1892, in 92 Michigan Reports, page 594.

PART III

LUMBER MARKETS AND MARKETING





## CHAPTER XV

### LUMBER TRADE ASSOCIATIONS

THE trade association idea has been an important link in the development of the lumber industry for more than fifty years. There are numerous organizations representing the divers phases of the lumber industry and closely allied lines. Among the more important ones are those of the lumber manufacturers, wholesalers, and retailers. There also are various organizations representing loggers, exporters, cross-tie manufacturers, producers of cedar products such as posts and poles, and manufacturers of boxes and box shooks, cooperage, and veneers.

Lumber manufacturers' organizations are regional or state in character with one national association. Retail organizations are usually bounded by state lines, although there are several sectional associations, and wholesale organizations usually are local, although there are two so-called national associations.

The regional manufacturers' organizations include those manufacturers who are interested in a given species or who operate in a given region and have many problems in common except, as in the southern yellow pine region, where the territory is so extensive that several organizations are in existence, each group covering a field having common business interests.

Few, if any of the lumber trade associations were incorporated bodies during the early period of association activity but in recent years many associations have found it expedient to incorporate and place the organization on a corporation basis.

The life of the early manufacturers' associations was short. They were organized for the accomplishment of some definite purpose, often connected with price control during dull market periods, and when the purpose for which the organization was founded had been accomplished or defeated it lapsed.

### MANUFACTURERS' ASSOCIATIONS

Among the first associations of manufacturers were the Missouri and Arkansas Yellow Pine Association, organized in 1882, and the

Northwestern Lumber Manufacturers' Association,<sup>1</sup> organized in 1883.

### **Southern Yellow Pine.**

The permanent type of manufacturers' association dates from 1890 when the Southern Lumber Manufacturers' Association was organized, which covered the southern pine field including the cypress and hardwood interests in the same region. At the time of its organization it was the largest lumber manufacturers' association in existence. It included in its membership manufacturers of the woods mentioned and also wholesale dealers who were admitted to honorary membership.

This organization continued under the original name until January, 1906, when it was changed to the Yellow Pine Manufacturers' Association, an organization which devoted its efforts exclusively to furthering southern yellow pine interests. It was reorganized under the name of the Southern Pine Association in December, 1915, and incorporated in Missouri as an organization for educational purposes and not for profit, offering service to southern yellow pine producers for a stated price.

The field of work outlined was more comprehensive than that of any other lumber manufacturers' association and embraced departments covering trade extension, research, inspection, legal matters, accounting and statistics, traffic, and forestry.<sup>2</sup>

The forestry department of the association has made an excellent inventory of the standing southern yellow pine timber and has been active in support of a national forest policy in line with the ideas of the lumber industry. It has not, in itself, attempted any technical forestry work, although in 1920 provision was made for generous financial support for studies of second-growth problems in southern pine under the auspices of the National Research Council.

The Southern Pine Association has received more support from southern pine operators than any of its predecessors, since under the reorganization many firms which had not affiliated, previously, joined in this co-operative effort. One reason for this was that the form of the earlier associations, which were not incorporated, made the individual members responsible for the acts of the organizations, while under the new charter the association is a corporation organized for the collection, preparation, and sale of data of interest to the industry and firms or individuals which purchase such information are not legally responsible for the acts of the corporation.

<sup>1</sup> This association embraced white pine mills on both sides of Lake Michigan and also those on the Mississippi river and in Wisconsin. It was disbanded in 1884.

<sup>2</sup> For the general scheme of organization of this association, including the form of subscription contracts see *American Lumberman*, Jan. 23, 1915, pp. 43 to 45.

This association is the largest sectional organization of lumber manufacturers' in the United States and has done much to increase the efficiency and promote the interests of the southern yellow pine industry.

The southeastern southern yellow pine interests, chiefly in East Florida and Georgia, were first organized in 1899<sup>1</sup> as the Georgia Sawmill Association. As the scope of the work of the association broadened and the territory covered increased, the desirability of a more distinctive title arose and on November 3, 1903, the name was changed to Georgia Interstate Saw Mill Association. On July 16, 1906, the name was again changed, at the time this organization was incorporated, to the Georgia-Florida Saw Mill Association, Inc., under which name it still continues to function. Its activities of late years have been developed along statistical, cost accounting, and advertising lines and do not differ in essentials from those of other regional associations.

### **North Carolina Pine.**

The southern yellow pine interests in the Carolinas and Virginia have had a general organization known as the North Carolina Pine Association since January 31, 1897, on which date the members of the North Carolina Pine Lumber Company, organized in 1889, voted to abandon their organization and to transfer its property to the new association.

Previous to 1897 various organizations had entered the field, among them the Carolina Dressed Lumber Association, organized May 6, 1891; the North Carolina Dressed Lumber Company, organized October 31, 1891; the Southern Dressed Lumber Association, organized February 1, 1895; and the Carolina Dressed Lumber Company, organized February 20, 1896. Each of these organizations was short lived, since they were formed chiefly to deal with current problems and it was impossible to hold the membership after such problems had been adjusted.<sup>2</sup>

The field of the North Carolina Pine Association was enlarged in 1905 by the absorption of the South Carolina Lumber Association. This union brought together the largest producers in the Coastal Plain region and the enlarged association has been the dominating factor in the lumber industry in the Carolinas and Virginia since that time.

### **Cypress.**

In 1890 the cypress lumber-producing interests had a local organization known as the Teche and Gulf Coast Cypress and Shingle Associa-

<sup>1</sup> See American Lumberman May 24, 1919, page 54.

<sup>2</sup> See Three Centuries of Development in North Carolina Pine, American Lumberman, June 8, 1907, pages 33 and 34, and June 22, 1907, pages 46 and 47.

tion. In 1893 an organization of cypress manufacturers in Louisiana and Arkansas known as the Southern Cypress Lumber and Shingle Association also existed which had formulated grading rules for rough and dressed lumber and adopted a set of weights for finished products.<sup>1</sup> On January 23, 1896, the Atlantic Coast Cypress Association was organized along the lines of the one in Louisiana and Arkansas, and covered cypress interests in Florida and the other Atlantic Coast states. The inspection rules of the Louisiana and Arkansas organization were adopted as the standard for the inspection of lumber.<sup>2</sup>

For a number of years previous to 1905, the cypress manufacturing interests lacked a general association, to handle their problems, although there were two organizations in the field, namely, the Southern Cypress Lumber Selling Company, Limited, and the Southern Cypress Lumber Association. The former was a "close" corporation organized to distribute the cypress products of its stockholders; the latter was an open association which any manufacturer of cypress lumber could join. Although the latter organization was separate from the selling company it employed the same secretary and used the same office and its membership was composed chiefly of the stockholders of the selling organization. The lumber association had no constitution, did not hold regular meetings, and its existence as an association separate from the sales organization was not generally recognized.

The desirability of forming an effective association of lumber manufacturers representing the entire cypress region was agitated during the early months of 1905, and on May 10th of that year cypress manufacturers, chiefly from Louisiana, met in New Orleans and organized The Southern Cypress Manufacturers' Association, an organization which has actively functioned since that time. For years, the association has advertised the product of its members very extensively and in the field of trade extension it has had one of the most advanced policies in existence among lumber trade organizations. The grading rules of the association have been adopted, almost universally, for the inspection of cypress lumber.

### White Pine.

In August, 1891, the white pine manufacturers in the Mississippi Valley region formed a permanent organization, known as the Mississippi Valley Lumbermen's Association, to which wholesalers also were

<sup>1</sup> The date of organization of this association is unknown but presumably it was some years previous to 1893 since the 13th meeting was held during that year.

<sup>2</sup> The date at which these associations lapsed is unknown.

admitted. On January 23, 1906, this association and the Wisconsin Valley Lumbermen's Association, organized in 1890, were merged to form the Northern Pine Manufacturers' Association which to-day is the official organization of the white pine operators in the Lake States.

### West Coast.

The operators in Washington organized in November, 1891, under the name of the Lumber Manufacturers' Association of the Northwest. This organization did not function for long. Permanent organization dates from January 10, 1901, at which time the Pacific Coast Lumber Manufacturers' Association was formed representing chiefly the Douglas fir interests. On August 25, 1911, the name of this association was changed to the West Coast Lumber Manufacturers' Association,<sup>1</sup> at which time two other associations, the Southwestern Washington Lumber Manufacturers' Association, and the Oregon and Washington Lumber Manufacturers' Association became affiliated with it. In 1915 it was re-organized and the scope of work enlarged under the name of the West Coast Lumbermen's Association, an incorporated organization.

### Hardwoods.

Hardwood interests made several attempts to organize in the "nineties." The National Association of Hardwood Lumber Manufacturers was organized in Chicago in May, 1891, the stated objects of which were: "mutual protection by establishing a national uniformity of grades, the regulation of prices and terms, more equitable rates of insurance, classification and transportation, more accurate commercial rating of customers, more frequent and friendly intercourse by the manufacturers of hardwood lumber." This association did not survive for long. Steps also were taken about this time by operators in the Memphis district to organize but so far as known nothing definite came from the effort.

In May, 1898, an organization known as the Mississippi Valley Hardwood Lumber Manufacturers' Association was launched with the object of formulating uniform rules of inspection for hardwood lumber, based on the view point of the manufacturer. Wholesalers in the previous month had organized the National Hardwood Lumber Association to promote uniform inspection of hardwood.<sup>2</sup> It is probable that the latter action served as a stimulus to the formation of a manufacturers' association since the producers had no general organization to look out for their interests.

The Hardwood Manufacturers' Association of the United States,

<sup>1</sup> This association was first incorporated at this time.

<sup>2</sup> See page 325.

organized in June, 1902, was the first permanent regional hardwood manufacturers' association in the country. This organization adopted a set of uniform grading rules for hardwood lumber and established a system of mill inspection for its membership. It later became an important factor in the hardwood field, and with several other hardwood associations it was merged into the American Hardwood Manufacturers' Association in 1918.<sup>1</sup>

The Michigan Hardwood Manufacturers' Association representing producers chiefly in the lower peninsula, but with some members in the upper peninsula, was organized on July 13, 1906. The collection and dissemination of statistical data on production, shipments, stocks, and sales has formed an important part of its work.

### Spruce.

The first organization of spruce lumber manufacturers in the Northeast, the Northeastern Lumbermen's Association, was organized in Boston on February 8, 1895, by operators in New England who represented about 80 per cent of the spruce cut in the region. The purposes of the organization as stated in its by-laws were "for mutual conference among proprietors of forest lands, log owners, manufacturers of long and short lumber, box makers and commission lumber merchants; co-operation in the sale of forest and mill products on an equitable, uniform and remunerative scale of prices; consideration of better methods of manufacture, transportation and distribution of lumber products." The chief activity was price control. The Northeastern Lumberman and Manufacturers' Gazette, Boston, was appointed the official organ of this association. The organization did not function for long, meeting the same fate that befell many other price control associations organized about the same time.

The Northeast has been without a general organization since that time, although local associations have functioned at various times. The most important association in the East at the present time is the Empire State Forest Products Association organized in December, 1909. This absorbed the Adirondack Lumber Manufacturers' and Shippers' Association organized four years previously. It represents Adirondack producers of spruce, hemlock, and hardwood lumber and has concerned itself not only with manufacturing problems, but also with general economic subjects affecting the welfare of the region and the state.

Appalachian spruce interests are not represented by an aggressive association. The Spruce Manufacturers' Association, representing

<sup>1</sup>See note, page 344.

West Virginia interests chiefly, was organized in April, 1909, for the stated purpose of collecting and distributing statistical data with reference to timberland acreage, lumber production and sales, fire losses in mills and forests, and to establish a standard inspection for spruce wood. The most important action of this organization was the formulation of Spruce Inspection Rules effective January 25, 1910, which have since been the standard for spruce lumber from this region.

### **Inland Empire.**

Inland Empire operators organized in February, 1903, under the name of the Western Pine Shippers' Association, covering the territory of Eastern Washington and Oregon, Western Montana, and Idaho. This association represented the pine, larch, and Douglas fir producers and was the outgrowth of a local association known as the Eastern Washington and Northern Idaho Lumbermen's Association. On February 6, 1906, the name of the organization was changed to the Western Pine Manufacturers' Association, under which name it has since conducted its activities.

### **Hemlock and Hardwoods.**

The Northern Hemlock and Hardwood Manufacturers' Association representing hemlock and hardwood interests in Wisconsin, Minnesota, and the Upper Peninsula of Michigan was organized on January 21, 1910, by the consolidation of the Northwestern Hemlock Manufacturers' Association and the Wisconsin Hardwood Lumbermen's Association.

The Hemlock Association was organized on June 6, 1895, to promote the sale of hemlock, to secure a uniform grade and price, and to further the interests of manufacturers by circulating a stock sheet among members. Inspection rules and a price list for hemlock were adopted at the organization meeting.

The hardwood association was organized in September, 1895, to standardize hardwood grades and inspection, and to furnish trade information to members, especially regarding stocks.

### **California Sugar and White Pine.**

The sugar and white pine interests of California were formed into an organization in August, 1910, known as the Pacific Coast Sugar and White Pine Lumber Manufacturers' Association "for the purpose of generally protecting and furthering the interests of Pacific Coast manufacturers of sugar and white pine in all ways consistent with the laws of the country and sound business principles, and particularly to become

affiliated with the National Lumber Manufacturers' Association as a member thereof."

On June 2, 1916, the California White and Sugar Pine Manufacturers' Association was organized and incorporated. The territory covered by the new association was more extensive than its predecessor, embracing mills from Southern Oregon to Arizona and New Mexico. The membership, however, was chiefly recruited from California.

The association has adopted standard grades and rules of inspection. It collects and disseminates statistics on production, shipments, and stocks, and performs other general services for its members.

### **Redwood.**

A general association, the California Redwood Association, representing redwood manufacturing interests was permanently organized early in 1916. An unincorporated association of the same name was in existence for a number of years previous to this. The former association represented 80 per cent of the redwood production at the time of its formation. The objects for which the organization was formed were to provide the members with statistical information, a grading and inspection service, traffic service, and to further the development of redwood domestic markets, through a publicity campaign.

### **The National Lumber Manufacturers' Association.<sup>1</sup>**

The need for some national organization which could take action in the name of the industry on matters of common interest to all lumber manufacturers in the United States became evident early in association history because many of the territorial associations were duplicating work at a relatively high expense and often with indifferent results because of a lack of unity of action.

The National Lumber Manufacturers' Association was organized in December, 1902, for the purpose of promoting uniformity in the methods of manufacture and sale of lumber; to handle, from a national view-

<sup>1</sup> The present subscribing associations to the National Lumber Manufacturers' Association are: California Redwood Association, San Francisco, Cal.; California White and Sugar Pine Association, San Francisco, Cal.; Georgia-Florida Saw Mill Association, Jacksonville, Fla.; Michigan Hardwood Manufacturers' Association, Cadillac, Mich.; North Carolina Pine Association, Norfolk, Va.; Northern Hemlock and Hardwood Manufacturers' Association, Oshkosh, Wis.; Northern Pine Manufacturers' Association, Minneapolis, Minn.; Southern Cypress Manufacturers' Association, New Orleans, La.; Southern Pine Association, New Orleans, La.; West Coast Lumbermen's Association, Seattle, Wash.; Western Pine Manufacturers' Association, Portland, Ore.; Western Forestry and Conservation Association, Portland, Ore.



point, matters of common interest; and to reconcile conflicting territorial interests.

Previous local and sectional associations had been composed of individuals or firms. The scheme of organization for the national association was one of delegated representation. Any association of lumber manufacturers was eligible for membership and was entitled to representation by two delegates at large, and one additional delegate for each 250 millions of board feet of lumber produced by association members.

The association efforts have been directed along several different lines among which are:

1. The collection, compilation and distribution of statistics, national in scope, designed to acquaint the members with market conditions in all parts of the country.
2. Adjustment of railroad transportation problems, such as car shortage, car stake equipment, and freight rates.
3. Formation of a uniform basis of credits and collections.
4. Formation and encouragement of inter-insurance organizations for the benefit of members.
5. Protection of lumber interests with reference to traffic laws on lumber.
6. Trade extension measures designed to increase the use of wood, and to combat adverse local or national legislation against the use of wood in building construction in cities.
7. Formulation of a national forest policy as representing the ideas and interests of the lumber industry.
8. Problems of national taxation as affecting the lumber industry.

The association membership in 1921 comprised twelve regional associations whose members manufacture 65 per cent of the lumber produced in the United States.

Although this association has not had the whole-hearted support of the lumber industry at all times, it has been able in recent years to greatly extend its activities and is now established on a sound basis.

#### EARLY MANUFACTURERS' ASSOCIATION ACTIVITIES

The chief object of the early local associations was control of market conditions by means of price agreements, and also regulation of production during dull market periods.<sup>1</sup> Coupled with these measures

<sup>1</sup>The object of the Northwestern Lumber Manufacturers' Association, organized in 1883, was price regulation as may be seen from the following editorial comment in the *Northwestern Lumberman*, Chicago, Illinois, Dec. 21, 1895. "The white pine manufacturers have once in their career tried organization for the curtailment of production as a means of sustaining prices. . . . The result of the organization effected was the agreement to reduce production of log input 15 per cent."

was the later effort on the part of some organizations to establish uniform grades and inspection as an additional means of stabilizing prices.

The platform of the Southern Lumber Manufacturers' Association, as stated by its Secretary at the semi-annual meeting on August 10, 1892, was as follows:<sup>1</sup>

1. "To establish grades which shall be sufficient in number to enable the manufacturer to secure the best possible returns for his product, and to maintain them so closely in accordance with specifications that buyers can rely on receiving equally good stock of the same grade from mills situated in different localities.
2. "To establish widths and thicknesses for dressed stock to to be known as standard, which shall be shipped in all cases where special sizes are not specified.
3. "To establish a ratio of prices between various grades and lengths as well as an official form of list, and recommend at regular intervals a schedule of prices which shall be in accord with market conditions—present and prospective.
4. "To establish a table of weights for dry and green, rough and dressed products of the long-leaf and short-leaf districts, which shall form a just basis for making delivered price lists, and settling claims with railroad companies for overcharge in weight.
5. "To collect, tabulate, and distribute, at stated times, information regarding the output, shipments and stock-on-hand, throughout the territory covered by the association.
6. "To settle through the Secretary's office claims for inferior grade, and for other causes which continually arise.
7. "To meet regularly and discuss questions which the changing conditions of supply and demand force upon us, and by so doing, to keep in touch with those who, though widely separated, have interests and thoughts in common.
8. "To investigate, and if deserving, foster undertakings which may tend to increase the consumption of our product, or secure from any portion of the product a greater return than has yet been received.
9. "To produce and distribute among manufacturers and retailers such literature as will tend to keep them informed on the work done by our convention and on important changes in any of the laws which govern or affect our industry."

This platform so far as is known, represents the first concerted effort

<sup>1</sup> See Southern Lumberman, Aug. 15, 1892, page 9.

of a large lumber trade association along the above lines and was regarded as essential to the accomplishment of the chief aim of the lumber trade associations of that time, namely, price control.<sup>1</sup>

The early lumber manufacturers' associations were not strongly supported by the industry. The lack of appreciation of the value of associated effort was shown in the great difficulty they experienced in the collection of the statistics necessary to form an opinion of the trend of the industry. Data on the annual lumber output in the Lake States were available as early as 1892, due to the efforts of the Northwestern Lumberman, which collected, compiled, and published the information annually. A southern statistical service was slower to develop, although strong efforts were made to inaugurate a satisfactory service. The Southern Lumber Manufacturers' Association soon after its organization undertook to carry out its announced intention of compiling statistics of production, shipments, and stocks-on-hand but met only with indifferent success for some years. It was not until 1896 that sufficient reports from operators were available to make it practicable to establish a series of monthly "yellow pine clearing-house" reports. The statistical work started by this association has been continued by its successors without interruption, although in a revised form and covering a more comprehensive field.

An interesting development in the lumber trade field was the formation of various co-operative companies during the early part of 1895. These companies were organized because of the demoralized condition in the lumber markets and were designed to include operators who sold lumber in a common field and who needed more co-operation than then existed through the agency of any organization, for regulating manufacture and maintaining prices. Such companies, while not confined to the southern pine field, were more numerous there than in other sections of the country. The southern companies, in general, represented a membership which had planing mill facilities at the saw-mill plants, and hence were composed of the larger operating concerns.<sup>2</sup> The various

<sup>1</sup>The Secretary of the association in his annual address said, "We have accomplished as much along the line of price fixing as any association of our kind and while we do not assert that our official list is lived up to by the majority, we claim that it is the best and truest expression of the general market prices of yellow pine now extant, and our effort should be to keep it so." *Northwestern Lumberman*, Aug. 15, 1891, page 9.

<sup>2</sup>Among the companies so organized in 1895 and 1896 were the following: Alabama Lumber Co., Ltd.; Arkansas and Missouri Yellow Pine Co.; Mutual Lumber Co. of Mississippi and Louisiana; Union Lumber Co., Ltd., of Texas; Northeastern Lumbermen's Association (Boston, Mass.); Redwood Company of California; North Carolina Dressed Lumber Co.; and the Southern Poplar Lumber Co.

organizations interested in a given kind of lumber co-operated more or less closely one with another and also with the Southern Lumber Manufacturers' Association but their period of existence was comparatively short as most of the organizations lapsed in 1896. It was found, with price control as the chief motive for organization, that members could not be held in line for an indefinite period.<sup>1</sup> Their united action, however, apparently had a beneficial effect on the price of southern yellow pine lumber since the President of the Southern Lumber Manufacturers' Association in his address at the annual meeting on February 19, 1896, said: "I congratulate the manufacturers of yellow pine that prices have been much better than they were when we met a year ago at our annual meeting. Thanks to members of the association for taking the lead, and by the united efforts of the manufacturers of Missouri, Arkansas, Mississippi, and Louisiana last spring, succeeded in getting the prices out of the ruinous rut they were in and saved the industry. And later on, the manufacturers of Texas also came to the rescue, and by gradual stages, prices have been advanced up to the present time. . . ."

The various manufacturers' associations engaged in price-control activities up to this time did not encounter adverse public opinion, as expressed by legal proceedings, except in the case of the Mississippi Valley Lumbermen's Association.<sup>2</sup>

<sup>1</sup>The following editorial comment on the organization and co-operation of the companies representing southern yellow pine interests appeared in the *Northwestern Lumberman*, Dec. 21, 1895, page 2. "To raise the yellow pine business to a profitable level, it was seen that there must be an organization of the milling interests, and that such organization must be comprehensive and wide spread. This measure was taken last year (1894) and worked into operative shape last spring. The result was the co-operative companies which now include the principal mills in Oklahoma, Mississippi, Louisiana, Texas, Arkansas, and Missouri. It has consolidated the long- and short-leaf pine interests of the states named, from which lumber is mostly marketed in the great northwest." . . . Through effective organization, in this year of unprofitable white pine manufacture and trade, the yellow pine business has yielded more profit than for several years.

As a sequel to the above, the following editorial comment in the same journal, page 3, under date of Nov. 21, 1896, is of interest. In speaking of the collapse of the Redwood association price list " . . . the whole question of whether any lumber organization with a fiat price list for a foundation can exist, is again opened up. A combination price list has never been a permanent success in the history of the trade. . . . Associations have been tried without number among all kinds of manufacturers from the spruce of New England to the white pine of the Northwest and the yellow pine of the South. . . . Beyond a temporary success, permitted more by the conditions surrounding the trade at the time than anything else, all attempts to maintain a fiat or combination price list have proven failures, and organizations based upon the maintenance of such a list have sooner or later gone to pieces."

<sup>2</sup> See page 337.

During the "nineties" there was marked progress made by lumber manufacturers' associations especially in the South and in the Lake States along lines other than price regulation, for sectional associations, as opposed to local or state associations, became well established and were the dominating factors in the industry. Uniform grading rules were formulated and perfected, an inspection service inaugurated, and for the first time concerted action on national legislation affecting the lumber industry was secured, especially with reference to a tariff on lumber.

One of the most important features of association endeavor was the attempt to secure the adoption of uniform grades for the various products. Local associations were unable to reconcile sectional differences and it was only when organizations like the Southern Lumber Manufacturers' Association and the Mississippi Valley Lumbermen's Association came into the field that unified action became possible. Even with a common meeting ground it took some years before the differences could be adjusted satisfactorily. The difficulties encountered in furthering this type of association activity are well illustrated by the experience of the operators in the Lake States region, who, in 1890, called a conference to see what could be done to make the grading and inspection methods uniform. A committee was appointed to visit the mills and to see what steps were necessary to bring about the desired reform. The report of the committee submitted about mid-year brought out the great discrepancy which existed in the procedure at the 55 mills inspected. No action was taken on the committee report, and strong opposition to any changes delayed action for some years. However, a uniform set of grading rules was drawn up by the association in 1895 and was printed and distributed in July of that year.

For many years there was a more or less continuous effort made by the various hardwood associations to reconcile the two forms of hardwood inspection, namely, that of the manufacturers' association and that of the National Hardwood Lumber Association. It was only in 1918 that a compromise was effected, the American Hardwood Manufacturers' Association, at that time, adopting the National Hardwood Lumber Association rules.

#### RECENT MANUFACTURERS' ASSOCIATION ACTIVITIES

There has been a marked change in the objects and aims of lumber trade association activities during recent years. Due to anti-trust proceedings brought against individuals and associations in various Federal courts, the idea of price control through the issuance of price lists, curtailments, and trade agreements has been largely abandoned. Regional

associations have incorporated, in nearly all instances, and efforts have been made to comply with the modern interpretation of the anti-trust laws.

The chief efforts of lumber trade associations to-day are devoted to maintaining uniform grades and inspection for the products of the industry, to collect and disseminate statistical data regarding the industry which is a benefit alike to producer and consumer, to further the use of wood by extensive advertising campaigns, to furnish data which will aid the consumer in the more intelligent use of wood, and to mold the policy of the industry with reference to important national questions. They are, therefore, organizations which are truly educational in character and, as such, are an important factor in the development and wise use of the products of our forests.

#### RETAIL ASSOCIATIONS

Associations of retail lumber dealers, from the standpoint of members, represent the largest organized element in the lumber industry. Some local retail organizations meet only at occasional intervals, sometimes annually, for the purpose of promoting a spirit of friendship and mutual understanding among the trade in the region. The majority of the state and sectional organizations, however, represent a highly organized group designed to furnish trade information and provide service for their members. Retail dealers' associations, with the exception of certain local wholesale lumber exchanges, represent the oldest organized co-operative efforts among the lumber trade.

The earliest record found of a retail association is that of the Iowa Retail Lumber Dealers' Association organized on June 8, 1876. The reason which led to the formation of this association was the great annoyance retail dealers suffered from the business practices of some wholesale firms shipping carload lots of lumber to a consumer for the same sum charged the retail dealer in the same town. The assumed justification for doing this appeared to rest upon the fact that the consumer paid cash, while the retail dealer expected and received from sixty to ninety days credit. The practice became so common that a member of a retail firm in Iowa called a meeting of retail dealers to meet at Des Moines on June 8, 1876, to take united action on the matter. The result of this meeting was the formation of the association mentioned. The measures adopted to stop the practice were, "if any wholesaler shipped a carload of lumber to anyone outside of a dealer, in any town where there was a member of the association, that member would notify the Secretary and the latter would draw upon the wholesaler who shipped the lumber a sight draft for \$10." The Secretary was

to send this amount to the member whose business was being cut. If the draft was not honored the association was pledged to a man to buy no more lumber from the offending wholesaler. The plan worked so well that within a year Illinois retail dealers came together and adopted the by-laws of the Iowa association.<sup>1</sup>

In the fall of 1877 the Iowa association was absorbed by the National Retail Lumber Dealers' Association with headquarters in Chicago. The membership was composed largely of dealers in Illinois, Southern Iowa, Kansas, and Missouri. This association was disbanded in 1890 because it was felt that the work could be done to better advantage by state organizations which did not attempt to cover such a large territory. Other retail associations were soon after organized, among them one in Ohio, Indiana, and Pennsylvania in 1881, one in New Jersey and one in Indiana in 1884, and one in New York and one in Texas in 1886. Since that time many other associations have been formed, every section of the country now being covered.

The New York association was probably the first distinctive retail association in the East. "Other organizations of similar character had been formed prior to 1886, but as a live and important factor in trade affairs and as a nucleus to the great association movement in the retail trade throughout the eastern states which followed its formation, the New York Lumber Trade Association has been sponsor to much of the good that has resulted to the eastern retail trade generally."<sup>2</sup>

Retail associations, from their inception, were chiefly "protective" in character and in the title of some of the early associations this word appears. The Secretary of one of the Middle Western retail organizations, in speaking of the objects of the early retail associations, said: "The original and almost sole purpose of the retail trade association was to protect its members against the sale of lumber directly to consumer, by the wholesalers. Big stick methods were used and justifiably so."<sup>3</sup> The importance of this phase of retail association work is also emphasized by the printed constitution of the Northwestern Lumbermen's Association, organized on January 29, 1890. The constitution states that the object of the association was "the protection of its members against sales by wholesale dealers and manufacturers to contractors

<sup>1</sup> See *American Lumberman*, April 30, 1904, pages 1 and 43.

<sup>2</sup> See *History of the Lumber Industry in America*, by J. E. Defebaugh, Vol. II, page 327. Published by *American Lumberman*, Chicago, Ill., 1907.

<sup>3</sup> From an address before the 25th annual meeting of the Illinois Lumber and Builders' Supply Dealers' Association of Illinois, by H. C. Searee, Secretary of the Retail Lumber Dealers' Association of Indiana. *American Lumberman*, Feb. 13, 1915, page 48.

and consumers, and the giving of such other protection as may be within the limits of the co-operative association."<sup>1</sup>

While originally intended to include the territory embraced within the states of Minnesota, Iowa, North Dakota, South Dakota, and Nebraska, this association did not have a large following in the latter state and a year or so later a separate organization was perfected in Nebraska.

About 1904 a new competitor of retail yards appeared in the form of mail-order houses which threatened to make serious inroads on the business, especially of rural retail lumber yards. Much time and effort has been devoted, by the various retail associations, to combat this form of competition. Frequent reference to this new element in retail lumber merchandising may be found in the reports of meetings, especially since 1905.<sup>2</sup>

Retail organizations also have devoted much thought to problems other than those which are "protective" in character. Mutual insurance has long been an established form of association effort and the total value of policies in force to-day aggregates many millions of dollars. The modern retail association is an information and service bureau for its members, especially with reference to improving the methods of merchandising lumber, including advertising and cost accounting.

Organizations, more or less national in character, have been formed at various times to unify association activities. The United Association of Lumbermen, organized in Chicago in June, 1890, was designed to bring together, once a year, the officers of retail associations to discuss and advise each other in the methods that should be pursued in association work. There were many retail associations organized and working independently of one another, with the result that there was a lack of harmony among them in dealing with manufacturers and wholesalers, whose market was not confined to the territorial limits of any one retail organization. The united association functioned until September, 1896, when it was merged into the Lumber Secretaries' Association. The United Association was composed wholly of retail secretaries while the Lumber Secretaries' Association apparently included association secretaries representing all branches of the trade.

In December, 1896, the latter organization drew up a "Universal Constitution," the objects of which were "to establish the equitable principle that the retailer shall not be subjected to competition with the parties from whom he buys; that a fair opportunity shall be offered the man who invests his time and money in the retail business and

<sup>1</sup> This constitution is printed in full in the Mississippi Valley Lumberman, Jan. 31, 1890, page 7.

<sup>2</sup> See page 386.



assumes the risk which such business inevitably involves; and to earn an adequate remuneration for his labor and the use of his capital. We seek also to promote that spirit of harmony in the trade which shall prompt every retail dealer to maintain friendly relations with his competitors at home, and his brother retailers everywhere."

This was submitted for approval to the various associations at their next annual meeting.<sup>1</sup> The basic principles embodied in the "universal constitution" were generally accepted by retail associations. Some years ago certain associations were convicted in the courts of their several states of operating in restraint of trade. In order to bring their organizations within the legal interpretation of legitimate activities, various modifications in the declaration of purpose and articles of association of retail lumber associations were made, and the objectionable features eliminated.

In the autumn of 1900, the secretaries of various retail associations, chiefly middle-western, which were affiliated with the Lumber Secretaries' Association, held a conference and organized the Retail Lumber Secretaries' Association, membership in which was confined exclusively to retail organizations. This action was taken because it was deemed desirable and expedient that the retailers have an exclusive organization to deal with their own problems. It was the sense of the meeting, however, that the new association should co-operate with the secretaries of manufacturers' and wholesalers' organizations. The Lumber Secretaries' Bureau of Information was incorporated in 1902 and absorbed the secretaries association. The Bureau of Information served as a clearing house for member retail organizations with reference to trade practices, and was one of the chief points of contact between the retailers and other branches of the lumber trade. The territory included in its membership was chiefly west of the Alleghany Mountains. A similar organization, the Eastern States Retail Lumber Dealers' Association, organized in 1902, covered some of the New England and north-eastern states along the Atlantic Seaboard.

The Bureau was an influential element in the conference held in December, 1902, at the time the National Lumber Manufacturers' Association was organized, at which time efforts were made to establish a "Code of Ethics" which should define the proper trade relations between the wholesale and retail lumbermen of the country. This was crystallized at a later conference, in 1908, at which time the American Lumber Trade Congress was organized. This congress drew up a "Code of Ethics" which was adopted in 1909.

As a result of retail association activities in attempting to confine

<sup>1</sup>The "Universal Constitution" was printed in full in the *Northwestern Lumberman*, Dec. 18, 1896, page 18.

the lumber trade within its "legitimate" channels, anti-trust proceedings were brought at different times against various associations, among them the Retail Lumber Dealers' Association of Mississippi and Louisiana, the Northwestern Lumbermen's Association, the Michigan Retail Lumber Dealers' Association, and the Colorado and Wyoming Lumber Dealers' Association.<sup>1</sup> Within recent years all associations have re-shaped their policies and procedures in line with the court decisions. Open agreements and attempts to regulate the relations existing between the various merchandising elements in the industry have been abandoned and the field of work has necessarily been forced into other channels.

As early as 1902 the need for more care in handling certain problems which confronted the associations was shown by a speech made by the President of the Retail Lumber Secretaries' Association. In speaking of a recent decision of the Nebraska Supreme Court he said:<sup>2</sup> "While the decision suggests the necessity for some radical changes in some portions of our work, it but emphasizes the policy which has dominated several of our associations for some years in the adoption of conciliation, rather than coercive measures in our dealings with the wholesale and manufacturing elements of the lumber trade. . . ."

Retail lumber trade associations have a wide legitimate field of work before them and this is being developed fully as successfully as the earlier lines of work which are now regarded as contrary to the law.

One of the latest sectional retail associations is the National Retail Lumber Dealers' Association organized in September, 1916. This association does not have any close relationship with the various other retail organizations. Its membership comprises dealers in the large cities, and its objects are the protection of the general interests of the members in the strongly competitive large city trade. Its activities also include inter-insurance for members.

#### WHOLESALE ASSOCIATIONS

The wholesale dealers in lumber early formed local organizations, known as clubs or exchanges, in the larger cities of the United States to promote the local interests of the members. Some were more or less social in character while others developed an organization designed to provide information and service with reference to credits and collections, local grading rules and inspection, statistics of lumber trade, and similar service. Local associations also have performed work of great value

<sup>1</sup> See page; 329 and 334 to 338 inclusive.

<sup>2</sup> Anderson *vs.* Nebraska Lumber Dealers' Association. See American Lumberman, Nov. 22, 1902, page 18.

to the lumber industry at large, in fighting anti-wood and other ordinances affecting the use of lumber in cities, and aiding in the formulation of building codes.

Among the earliest local associations were the Cleveland (Ohio) Board of Lumber Dealers, organized in 1866; the Lumbermen's Association of Chicago, organized in 1869; and The Lumber Exchange of Baltimore, organized in 1875. Following this period, organizations multiplied rapidly and now cover every large city of the country. These organizations have not always been confined to wholesalers as other branches of the trade often have been admitted to membership. The wholesale dealers, however, have been the potent force in maintaining the organizations in nearly every case.

The confusion which existed between wholesalers and retailers with reference to trade relations could not be satisfactorily adjusted by local associations and it soon became evident that some sectional organization was necessary to amicably adjust the trade differences between them. As a consequence, a preliminary meeting was called by wholesale lumber dealers in New York in April, 1893, for the purpose of forming an organization for the adjustment of the differences which existed between the wholesalers and retailers. The objects of this meeting as set forth in the announcement were to seek a remedy for certain trade abuses, among which were (a) the elimination of wholesalers who sell to customers of retail yards, (b) to report retailers who do not do business on a reputable basis, (c) to consider rules for the inspection of lumber, and (d) to devise ways and means for settling complaints regarding shipments.<sup>1</sup> The outcome of this meeting was the organization of the National Wholesale Lumber Dealers' Association, which has had an uninterrupted existence to date. Its membership now extends from Chicago to the Atlantic Seaboard, including Eastern Canada.

The early history of this organization deals largely with the subject of trade relations, especially with retailers, although other lines of work were soon started. Among the important phases of association work which were developed were transportation matters of interest to members, inter-insurance, and credits and collections. The latter work apparently was regarded as being of much importance and the Bureau of Information, which handled such matters, proved of great service.

This association was one of the first to give the subject of forestry a prominent place in its meetings. Addresses on forestry were on the program from 1899 on, and in 1902, a Committee on Forestry was added to its list of permanent committees. Marked interest was taken in the forestry questions of the day and active support was given to

<sup>1</sup> See Southern Lumberman, Jan. 1, 1894, page 4.

measures such as the White Mountain-Appalachian Bill, later enacted into law and now known as the Weeks Law.

Credit also must be given to this organization for the first public expression on the part of a lumber-trade association for the necessity of enforcing a system of forestry which would guarantee to this country a permanent timber supply. At the annual meeting in 1902 in the report of the legal department, the association counsel said: "It seems inevitable that some closer organization of the lumber industry will take place in the not very distant future and that such organization will have as one of its reasons for existence the enforcement, either with or without government co-operation, of a forestry system." The association evidently referred to, the National Lumber Manufacturers' Association, did come into existence in December, 1902, but as yet it has not accepted as one of the chief reasons for its existence the enforcement of a forestry policy.

The relations between the wholesale and retail trade did not run smoothly and in 1899 a conference of members of the association and of retailers was held to discuss measures for the better protection of retail merchants in the matter of shipments by wholesalers to those whom the retailers regarded as their legitimate customers. The outcome of this conference, held in conjunction with the annual meeting, was the adoption of the "Boston Agreement" which stated that whenever it shall have been determined by the board of trustees of the association, or through committees acting separately or in conference with any authorized body from a retail association, "that any person, firm or corporation is not a legitimate customer for the wholesale trade . . . the members shall not thereafter sell to such person, firm or corporation."<sup>1</sup>

Retail associations both in the Middle West and in the East co-operated with the wholesale association in the "classification" of the trade and related matters until 1903 when the retail associations withdrew from the "Boston" and all other agreements in order that they might continue to affiliate with the Lumber Secretaries' Bureau of Information, the charter of which forbade affiliation with any association using "classifications."

The refusal of the wholesale association to agree to the retailers' views regarding the classification of carpenters and contractors, and also the fear of legal entanglements in view of the decision<sup>2</sup> of the Nebraska Supreme Court in 1902, evidently had some weight in bringing about

<sup>1</sup> See, *American Lumberman*, March 11, 1899, page 19, for the amendments to the by-laws comprising the so-called "Boston Agreement." This was so-called because the agreement was made at the annual meeting held in Boston in March, 1899.

<sup>2</sup> See page 328.

the withdrawal of the retail dealers from the agreements which had been in force during preceding years.

Although the wholesale association and the retail organizations ceased to have any written agreement, their differences were soon adjusted and it is assumed that there was an informal understanding relating to the classification of the trade, since the retailers continued to attend the annual meetings of the wholesalers.

The work of the wholesale association expanded rapidly, with an increase in membership, eleven separate departments reporting at the 1907 annual meeting. In 1908, through its delegated representatives, it took part in the American Lumber Trades Congress and helped formulate the "Code of Ethics" which was drawn up by all branches of the trade and adopted at the 1910 annual meeting. This association still continues to function in a progressive manner and remains the dominating wholesale organization east of the Mississippi River.

The wholesale interests of the West Coast have had a regional association since 1898, first organized to maintain an agent at the "Minnesota Transfer"<sup>1</sup> to look after the shipments of members at this point. It was reorganized in 1908 and now covers a wider field of work. It still functions under the name of the Pacific Coast Shippers' Association.

Another form of wholesale organization known as the National Hardwood Lumber Association was organized in April, 1898, to promote uniform inspection and grading of hardwood lumber. Its membership is composed of delegates from various local hardwood organizations. One of the early acts of this organization was the formulation of a set of rules for the inspection of hardwood lumber, from the wholesalers' point of view. An inspection department with a corps of licensed inspectors located in the chief producing and consuming centers has been one of the important phases of the work of this association. The grading rules of this organization became the standard for hardwood inspection on September 1, 1919, when the American Hardwood Manufacturers' Association abandoned their rules of inspection and adopted those of the National Hardwood Lumber Association. This, to a large extent, cleared up the great confusion which had existed for more than twenty years due to the existence of separate rules maintained by each organization.

A true national organization of wholesale lumber dealers did not exist prior to 1920. On May 22 of that year, the American Wholesale Lumber Association was organized as a result of the co-operative efforts of some three hundred wholesale firms which had formed, in 1918, what was known as the National Bureau of Wholesale Distributors, to establish before the War Industries Board the claim of wholesale dealers

<sup>1</sup> See page 367.

that they were an essential element in the distribution of lumber during the war. The necessity which prompted this action was the threatened elimination of the wholesaler by the said Board, as being a non-essential factor in winning the war. The success of this organization in thoroughly establishing the rights of the wholesaler led its supporters to call a meeting for the continuance of a national co-operative effort in times of peace.

The objects and purposes for which this association was organized were:

- (a) "To enhance the standing and reputation of the wholesale branch of the lumber industry;
- (b) "To afford an agency for the protection and maintenance of the wholesaler as an essential factor in the lumber industry;
- (c) "To coordinate the efforts of the wholesale organizations of the United States in such a manner as will best serve the needs of the industry and protect the interests of the public;
- (d) "To aid in the more efficient distribution of lumber and forest products through the standardization of grades and sizes, through the elimination of unfair practices and trade abuses in co-operation with the proper Government officials, through interchange of information as to improved methods of handling and distribution and by any other means; and
- (e) "To co-operate with all branches of the lumber industry in all constructive programs for the advancement of the industry and in the collection and dissemination of the information as to the value and uses of lumber and forest products in order that the maximum consumption of these products may be maintained."

Active membership in the organization is confined to those persons, firms, or corporations, 60 per cent of whose total volume of business, in board feet, consists of the distribution of lumber at wholesale, and associate membership is confined to those engaged in any branch of the lumber business, other than wholesale. Honorary membership may be conferred on any person who has rendered service which has aided in the general advancement of the lumber industry. The keen interest manifested in this organization by wholesale dealers in all parts of the country indicates the field of usefulness of an organization of this character.

## LEGAL PROCEEDINGS AGAINST THE LUMBER INDUSTRY

Various legal questions have arisen in connection with lumber trade association activities, chiefly with reference to co-operative marketing, joint selling agencies, price control, and the classification of the "channels of trade."

**Santa Clara Valley Mill and Lumber Company.**

One of the early cases of trust activities, as affecting lumber manufacturers, was that of the Santa Clara Valley Mill and Lumber Company, near Felton, California. The members of this firm, in 1881, devised a plan for the control of the entire output of all mills in four adjacent counties in California, either by leasing the mills for the year 1881 or by making a contract for the delivery of all lumber to the company at a stated price, under a penalty for every thousand board feet that was not delivered. The object was to create a lumber monopoly by forming a combination of all manufacturers at or near Felton for the sole purpose of increasing the price of lumber. One firm, party to the agreement, failed to comply with the contract and suit was brought against it for breach of contract. The Supreme Court of California, in 1888, declared the contract illegal and therefore not enforceable in the courts.

**Mississippi Valley Lumbermen's Association.**

Associations were not seriously opposed by the courts previous to 1892, at which time various members of the Mississippi Valley Lumbermen's Association were indicted in the United States court in Minnesota for operating a lumber trust in violation of an Act<sup>1</sup> of Congress passed in 1890 prohibiting combinations in restraint of trade between states. The court action was based upon a resolution passed at a meeting of the association in September, 1891, which expressed the sense of the association that the price of lumber should be advanced one dollar per thousand board feet. This indictment was later quashed and the association allowed to continue its activities.

**Northwestern Lumbermen's Association.<sup>2</sup>**

In May, 1892, the Bohn Manufacturing Company secured a temporary injunction against the Northwestern Lumbermen's Association, preventing the association from sending out a circular to members notifying them that the Bohn Manufacturing Company was no longer

<sup>1</sup> The Sherman Act.

<sup>2</sup> See page 319.

in sympathy with the objects of the association. This case<sup>1</sup> was one of the first brought before the courts to determine the rights of associations of retailers to take steps to prevent the sale of lumber by wholesalers to consumers.

The lower court having granted a temporary injunction preventing the association from issuing the circular, the case was appealed to the Supreme Court of Minnesota, which, in July, 1893, reversed the decision of the lower court and dissolved the injunction. In summing up the case the Supreme Court Judge said: "It is perfectly lawful for any man (unless under contract obligation or unless employment charges him with some public duty) to refuse to work for or to deal with any man or class of men as he sees fit. This doctrine is founded upon the fundamental right of every man to conduct his own business in his own way subject only to the condition that he does not interfere with the legal rights of others. And as has been already said, the right which one man may exercise singly, many after consultation may agree to exercise jointly and make simultaneous declaration of their choice. This has been held repeatedly as to associations or unions of workmen; and associations of men in other occupations or lines of business must be governed by the same principles.

"Summed up and stripped of all extraneous matter this is all that defendants have done or threaten to do and we fail to see anything unlawful or actionable in it."<sup>2</sup>

### **Nebraska Lumber Dealers' Association.**

The Northwestern decision gave added strength to association activities along the line of control of trade practices and was an accepted policy until 1902 when the Nebraska Lumber Dealers' Association became involved in a suit brought by a contractor who claimed damages because the association had taken steps to prevent certain wholesale lumber dealers from selling and shipping lumber to him, on the basis that he was not a retail dealer.

Judgment was granted to the plaintiff by the lower courts, but the case was dismissed by the State Supreme Court, in so far as the association was concerned, because it was not incorporated and was not organized to hold property or carry on any trade or business within the state. The Court held, however, that certain provisions of the constitution and by-laws of the association were in conflict with the statutes of the State. This referred especially to those provisions which attempted

<sup>1</sup> Bohn Manufacturing Company *vs.* W. G. Hollis et al.

<sup>2</sup> A full text of the decision may be found in the Mississippi Valley Lumberman, July 29, 1893, page 3.



to specify those whom the retailers regarded as legitimate customers of the wholesale trade.

### **Retail Lumber Dealers' Association of Mississippi and Louisiana**

The Mississippi Legislature in January, 1906, passed a resolution appointing a committee to investigate the lumber industry in the State and report whether there existed "a trust and combine for the purpose of regulating and fixing the price of lumber material. . . ."

The committee reported in March of the same year, a majority report submitted by three of the four members recommending that all of the evidence and "a copy of this report be referred to the attorney-general and that he be instructed, . . . to proceed as is provided under the anti-trust laws of the State of Mississippi to break up and destroy the present system under which the retail dealers of Mississippi and Louisiana are operating their business." The minority report held that the investigation did not show any lumber combination or trust in Mississippi.

Apparently no action was taken by the attorney-general at that time for at the 11th Annual Meeting of the Retail Dealers' Association of Mississippi and Louisiana, held in September, 1907, a resolution was passed asking the attorney-general of Mississippi to bring a friendly suit against the association to determine the legality of its constitution. This matter had previously been under discussion by the members, but definite action was taken at this time because the attorney-general had stated that he proposed to bring suit against the retailers, charging them with violation of the state anti-trust laws. Formal action was brought in February, 1908, resulting later in the conviction of and the imposition of fines against the members of the association, and a decree dissolving the organization.<sup>1</sup>

### **Lumber Trust.**

The years 1906 and 1907 marked the high point in the so-called "lumber trust" investigations in this country. Senator Kittredge of South Dakota, on December 6, 1906, introduced a resolution in the U. S. Senate authorizing the Secretary of Commerce and Labor "immediately to inquire, investigate and report to Congress, or to the President when Congress is not in session, from time to time as the investigation proceeds, as to the lumber trade or business of the United States which is

<sup>1</sup> The full text of the Supreme Court of Mississippi decision may be found in the Lumber Trade Journal, April 15, 1909, pages 30 and 31. The brief presented to the State Supreme Court by the attorneys for the association may be found in the Southern Lumberman, April 25, 1908, pages 30 to 34, inclusive.

the subject of interstate or foreign commerce and make full inquiry into the cause or causes of the high price of lumber in its various stages of manufacture from the log; and the said investigation and inquiry shall be conducted with the particular object of ascertaining whether or not there exists among any corporations or persons engaged in the manufacture or sale of lumber any combination, conspiracy, trust, agreement or contract intended to operate in restraint of lawful trade or commerce in lumber or to increase the market price of lumber in any part of the United States."<sup>1</sup>

The result of this resolution was an investigation, carried on during a period of several years, the conclusions of which were published in reports issued during 1913 and 1914.<sup>2</sup>

Part I reviewed the situation in the United States with reference to standing timber, including supply, concentration of ownership, acreage of timber holdings, value of standing timber, public-land policy, and general land laws as influencing concentration of ownership. The foremost facts shown by this report as stated in the letter of transmittal of the Commissioner of Corporations were:

- (1) The concentration of a dominating control of our standing timber in a comparatively few holdings, steadily tending towards a central control of the lumber industry.
- (2) Vast speculative purchases and holdings of timberland far in advance of any use thereof.
- (3) An enormous increase in the value of this diminishing natural resource, with great profits to the owner. This value, by the very nature of standing timber, the holder neither creates nor substantially enhances.

Part II was devoted wholly to a discussion of concentration of timber ownership in selected regions, and Part III to large holdings of timber owners. These two parts, combined in one volume, were prepared to show the tendencies which exist towards a gradual concentration of our timber resources in the hands of a relatively few firms, corporations and individuals; the conditions which have made such combinations possible; and the economic situation which may result from such ownership.

<sup>1</sup> The full text of the resolution may be found in *American Lumberman*, Dec. 22, 1906, page 29.

<sup>2</sup> These reports were as follows: *The Lumber Industry. Part I. Standing Timber.* Department of Commerce and Labor, Bureau of Corporations, Washington, Jan. 20, 1913. *Part II. Concentration of Timber Ownership in Important Selected Regions.* *Part III. Land Holdings of Large Timber Owners,* July 13, 1914. *Part IV. Conditions in Production and Wholesale Distribution Including Wholesale Prices,* April 21, 1914.

Part IV deals with lumber trade association activities and the influence which such organizations have exerted on the trade. The report treats of the price list, curtailment, and other activities of the various associations which might be construed as an attempt to control the lumber market.

All of these reports met with a very unfavorable reception from the industry on the grounds that they were a biased and inaccurate portrayal of conditions, and therefore constituted an unwarranted condemnation of the lumber operators of the country. No court proceedings or legislative acts grew directly out of this investigation.

### **Yellow Pine Manufacturers' Association.**

One of the most important "lumber trust" proceedings was the action of the attorney-general of Missouri who, on October 5, 1907, appeared before the Chief Justice of the State Supreme Court and filed informations against forty-seven wholesale lumber companies doing business in Missouri. He asked that the Court appoint a commissioner to take testimony for the purpose of ascertaining whether a lumber trust was operating in the State.

A commissioner was appointed with power to administer oaths and to require witnesses to answer such relevant questions as might be put to them concerning any contract, agreement, arrangement, combination, or understanding made and entered into by the corporations, in violation of the laws of the state.

Hearings were held before the Commissioner and an attempt was made to establish the fact that illegal trade relations existed between the various branches of the lumber trade operating within the state. The results of these hearings were the ouster, quo warranto, and injunction suits filed against certain lumber companies operating in the state which were members of the Yellow Pine Manufacturers' Association. Similar suits were filed in their respective states by the attorneys-general of Missouri, and Oklahoma, in a concerted effort to break up what was alleged to be an illegal combination to raise the price of lumber to an unreasonable and fictitious level.<sup>1</sup>

The immediate object of filing these suits was to prevent the consolidation of the interests of various southern yellow pine operations, with a reported capital of \$300,000,000, which it was believed was in the process of formation. Meetings of yellow pine producers had been held on February 11th, April 26th, and July 8th, to discuss the possibility of forming such a corporation to take over the holdings and operations of some of the largest producers of yellow pine in the South, but

<sup>1</sup>See The New York Lumber Trade Journal, Aug. 15, 1908, page 10.

no definite action, with reference to the formation of such an organization, was taken.

Although the Missouri suit was inaugurated on July 30, 1908, the first hearing was held May 22 to 25, 1911. In the meantime the number of firms named in the suit had dwindled from forty-seven to thirty-eight.

At this and subsequent hearings an attempt was made to bring out the price-list, curtailment, and other alleged activities of the Yellow Pine Manufacturers' Association of which the defendants were members, and the trade relations agreements which the association had entered into with various wholesale and retail associations. The final arguments in the case were heard on June 10, 1912. The Special Commissioner, appointed by the State Supreme Court, reported his findings to the latter body on August 1, 1912. Some of the conclusions embodied in the Special Commissioner's report follow:

"That the methods of respondents by concerted action with and through the association and the curtailment of the product of the lumber at their mills from time to time served to unlawfully limit and restrain the amount of lumber imported, manufactured and sold in Missouri, there can be no doubt; and that by such curtailment of the product the amount of lumber offered for sale in Missouri was kept at a maximum which enabled the respondents by the control they had thereof to further control the prices and trade in lumber in Missouri; such methods were unlawful agreements and understandings and were unlawfully designed for the purposes above enumerated and had such tendency and effect; that the methods and practices of the respondents by cooperating through the Yellow Pine Manufacturers' Association with the Southwestern Lumbermen's Association and with the Lumber Secretaries' Bureau of Information in their practices and purposes; its open alliance with these organizations for the establishment and enforcement of so-called rules of ethics in the trade, for division of territory among retail dealers and for the exclusion from the trade in Missouri of the dealers there, in terms of the parlance of the trade "poachers," "farmers' cooperative yards," etc., in the agreement with the Lumber Secretaries' Bureau of Information, known in the record as Trade Relations Agreement, by which it agreed to sell only to so-called "legitimate" retail dealers in Missouri under the protection of the Southwestern Lumbermen's Association, and in turn the members of the Southwestern Lumbermen's Association agreed to purchase their supplies from respondents as members of the Yellow Pine Manufacturers' Association; and all matters tending to limit free and lawful competition in such trade in Missouri were all in restraint of trade.

"Bearing the facts in the record in mind the Southwestern Lumbermen's Association, the Lumber Secretaries' Bureau of Information, and the National Lumber Manufacturers' Association are each respectively unlawful pools, trusts, agreements, combinations, arrangements, and understandings, respectively designed with the unlawful purpose of restraining trade and competition in lumber in Missouri, and are respectively conspiracies in restraint of trade and likewise their respective policies are unlawful and in restraint of trade."

The decision of the Supreme Court was handed down on December 24, 1912. It found twenty-five firms guilty on two out of seventy-six counts, namely, conspiracy to limit the output or amount of yellow pine

to be manufactured in Missouri, and the fixing of prices to be charged in Missouri for such lumber.

The sentences imposed were fines and revocations of licenses for four "foreign" corporations, fines and forfeiture of corporate rights, privileges, and franchises for twenty firms, and a fine only for one firm. These fines ranged in amounts from \$1000 to \$50,000 and were to be paid into the state treasury within thirty days.

In the case of ten firms, the Court held that the ends of justice would be subserved by granting a stay of execution, pending the further order of the Court, of the decree of forfeiture and ouster, provided the fines were paid within thirty days, and also provided the firms fulfilled such conditions of continuing good behavior as might later be laid down by the court.

On March 30, 1913, some of the firms which had been fined and ousted from the state agreed not to appeal to the Federal Courts, and asked for a reduction of the fines and a modification of the ouster decree so that they might continue in business within the state.

On July 2, 1913, the Supreme Court handed down a ruling with reference to the various petitions. The ouster judgment was suspended during the good behavior of the twenty-four ousted firms and the fines against four of them were reduced. Among the conditions laid down as essential to the suspension of the ouster judgment were the payments of the fines within sixty days, withdrawal from any direct or indirect connection with the Yellow Pine Manufacturers' Association, and observance in every way of the laws of the state.<sup>1</sup>

Some of the fines were never collected since certain firms went out of business before the suit was brought, one failed, others had no property within the state, and some moved their offices into other states.

Closely linked up with the so-called "Missouri Ouster Case" was the action of the attorney-general of Texas who, in 1907, appeared before the state legislature and charged that lumber manufacturers and retail dealers through their various associations and through the National Lumber Manufacturers' Association dominated one of the greatest resources of the country to their own personal advantage.

### **Toledo (Ohio) Retailers.**

During an era of very active building in the city of Toledo, Ohio, in 1907, the prosecuting attorney secured the indictment of twenty-seven individuals, members of fourteen retail firms, before the Grand Jury, under the charge that they were operating in violation of the state anti-

<sup>1</sup>The text of the ruling may be found in the *American Lumberman*, July 11, 1914, page 28.

trust law, which had been passed some two years previous. The basis for the indictment was that these individuals, as members of the Lumbermen's Bureau of Credit Company, were operating in restraint of trade. The firms to which the indicted individuals belonged represented about one-half of the number of retail companies in Toledo who had formed a credit company in order to furnish credit information only.

The indicted individuals pleaded guilty to a technical violation of the law and later were sentenced to imprisonment. The lumber trust case was a part of a campaign directed against all branches of the building trade and the result of the indictment was an immediate stagnation in the building trade which continued for a year, to the great detriment of the city. The lumber cases were not definitely settled until 1908 when the prison sentences, against the strong remonstrance of the prosecuting attorney, were revoked and fines substituted for them. A petition signed by more than 9000 citizens of Toledo, asking the court to exercise clemency in the case of the convicted lumber dealers, indicated the lack of the sympathy of the people with the attempt of the legal authorities to imprison the defendants.

#### **Eastern States Retail Lumber Dealers' Association.**

The seat of the lumber trust investigations was next transferred to the East. The United States Attorney-General on May 19, 1911, filed a petition in equity against the Eastern States Retail Lumber Dealers' Association<sup>1</sup> and the organizations which comprised its membership.<sup>2</sup> The petition charged that the defendants had by means of constitutions, by-laws, purposes, rules, regulations, agreements, and correspondence fixed, established, and maintained arbitrary divisions of the lumber trade in inter-state commerce whereby inter-state trade and commerce was unreasonably restrained and competition unreasonably prevented and unduly restricted.

One of the chief points in the case of the prosecution was the issuance of so-called "Official Reports," the circulation of which "seems to be the extent of their offending." These official reports or lists, sent to

<sup>1</sup> See page 321.

<sup>2</sup> The organizations and parties involved were the officers, directors, members, and delegates of the above association; the officers and directors of the New York Lumber Trade Association, the New Jersey Lumbermen's Protective Association, the Building Material Men's Association of Westchester County, New York, Retail Lumbermen's Association of Philadelphia, the Lumber Dealers' Association of Connecticut, the Massachusetts Retail Lumber Dealers' Association, Lumber Dealers' Association of Rhode Island, the Retail Lumbermen's Association of Baltimore, and certain individuals, officers, directors, or members of the Lumber Exchange of the District of Columbia.

members, contained confidential data with reference to wholesale dealers or other persons soliciting, quoting, or selling directly to consumers.

On January 9, 1913, a decision was filed in the Federal District Court in New York, granting a permanent injunction against the Eastern States Retail Lumber Dealers' Association and others involved in the suit, which forbade the further circulation of "official reports" or lists. The case was submitted to the U. S. Supreme Court in October, 1913, which, in June, 1914, handed down a decision upholding the action of the lower court. This decision settled the legality of this phase of retail association work which, in most instances, had been abandoned previous to the time the suit was brought against the Eastern association.

### **Lumber Secretaries' Bureau of Information.**

The attempt of the Federal Government to stop the issuance of statements by retail associations concerning those actions which retailers regarded as unethical trade practices, resulted in an indictment being returned against fourteen secretaries of retail lumber dealers' associations by the grand jury of the U. S. District Court of the Northern District of Illinois on June 23, 1911.<sup>1</sup> These secretaries were members of the Lumber Secretaries' Bureau of Information.<sup>2</sup>

The indictment charged an unlawful and felonious conspiracy to restrain inter-state trade by means of the publication of the names of manufacturers and wholesale dealers who sold lumber to mail-order houses, farmers' co-operative yards, contractors, and consumers. The chief basis for the indictment was the correspondence between the various secretaries, the acts of the Bureau of Information, and the publication in the Scout<sup>3</sup> of the names of concerns supplying mail-order houses or selling directly to other than retailers. It was stated that a detective agency was employed to secure data for publication in the Scout about wholesalers and others who violated the retailers' rules governing trade practices.

On September 18, 1911, the defendants filed a demurrer to the indictment with the District Court stating they had committed no offense against the United States, and asked that they be dismissed and discharged from all matters set forth in the indictment, and on June 7, 1913, the criminal indictments returned against the secretaries

<sup>1</sup> The full text of the indictment may be found in the American Lumberman, July 1, 1911, pages 35 to 38.

<sup>2</sup> See page 321.

<sup>3</sup> A paper published in Detroit, Mich., by the Michigan Retail Lumber Dealers' Association.

of the fourteen retail associations were dismissed because of insufficient evidence.

Three civil suits followed the dismissal of the original indictments, namely, a suit filed August 31st in the U. S. Circuit Court at Detroit, Michigan, against the officers and directors of the Michigan Retail Lumber Dealers' Association, the Scout Publishing Co. of Detroit, and the Lumber Secretaries' Bureau of Information; one filed in the U. S. Circuit Court, Minnesota District, in October, 1911, against the officers and directors of the Northwestern Lumbermen's Association, the Lumber Secretaries' Bureau of Information, Luke W. Boyce, a licensed detective, The Lumberman Publishing Company, and Platt B. Walker, editor of the Mississippi Valley Lumberman and manager of The Lumberman Publishing Co.; and one filed against the officers and directors of the Colorado and Wyoming Lumber Dealers' Association, and the Lumber Secretaries' Bureau of Information.

The defendants in these various suits were charged with operating in restraint of trade and the Government sought to force the abatement of the illegal practices charged against them by the dissolution of the organizations.

The charges against the various defendants did not differ materially in their general character. The suit against the members of the Northwestern Lumbermen's Association and others, filed in the Minnesota courts, was the fifth one instituted by the Government against the retail trade.

### **Northwestern Lumbermen's Association.**

The suit against the Northwestern Lumbermen's Association was the only one actively pressed by the Government, since a decision rendered in this case would settle the main questions at issue in the other two suits. The relief asked for in the petition of the Government in the Northwestern case was as follows:

1. "That it be adjudged that the defendants above named have entered into and are now engaged in a conspiracy and combination in restraint of trade and commerce.
2. "That the Lumber Secretaries' Bureau of Information and its officers and members as aforesaid be declared to be carrying on an illegal conspiracy and combination . . . and that said association be restrained and prohibited from doing anything in pursuance of or in furtherance of perpetuating the same.
3. "That (here are mentioned the officers and directors of the Northwestern) be perpetually enjoined from doing any act in pursuance to or for the purpose of carrying out such conspiracy and combination, and from contributing to or having membership in or cooperating with the Lumber Secretaries' Bureau of Information, its officers and directors; and



that they and Luke W. Boyce, and the Lumber Secretaries' Bureau of Information, defendants herein, be perpetually enjoined from cooperating with said Platt B. Walker and the Lumberman's Publishing Company in the manner herein alleged—that is to say, by furnishing information of sales and shipments by manufacturers and wholesalers to consumers.

“That Platt B. Walker and the Lumberman's Publishing Company be perpetually enjoined from publishing in the said Mississippi Valley Lumberman, or by means of letters or circulars, anything showing the names of, and methods of business adopted by manufacturers and wholesalers who are alleged to have sold and shipped lumber or lumber products to so called consumers.”

The defendants filed an answer on December 30th denying that they were or had been engaged in any conspiracy in restraint of trade; disavowing that any trade paper during the previous sixteen years had been recognized as the official organ of the Northwestern Lumbermen's Association, or that there existed any conspiracy with any publisher having for its object the publication of any matter in furtherance of a combination or conspiracy of any kind; declaring to be untrue any unlawful intent as the basis of the formation of the various associations; denying any arrangement between the defendants and credit rating bureaus to impair the interests of any class of consumers or to establish arbitrary classifications in the trade for unlawful purposes; acknowledging that so-called customers' lists had been furnished to members, but only to supply such members with needed information of legitimate character; admitting the employment of a detective bureau to gather trade information, some of it with reference to non-ethical shipments and that information so gathered was used by the Secretary in correspondence with members and for publication as news items.

Numerous hearings were held to take testimony in the suit, which was reviewed by the District Court Judge on March 14, 1917.<sup>1</sup> The judge in summing up the case said:

“In my judgment, the Government has clearly made out a case within the statute . . . and is entitled to relief by way of injunction.

“It is proper to add that the defendants have, each of them, activities other than those above criticised, of wide range and considerable importance, in reference to which no complaint is made.

“The injunction should therefore be against the several defendants, but directed specifically toward the illegal activities heretofore and at the time of the filing of the bill carried on by them in interference with and restraint of interstate commerce, to wit: The use of customers' lists in collecting, compiling and distributing information whether to the members of the association, to trade publications or other newspapers,

<sup>1</sup> For the full text of the review and injunction see *American Lumberman*, March 24, 1917, pages 52 and 53.

to credit agencies or to the public at large, as to sales by wholesalers and manufacturers direct to consumer, including mail-order houses and cooperative yards."

The final court decision was handed down in July, 1917, the association being permanently enjoined from publishing customers' lists containing sales made by manufacturers and wholesalers directly to consumers.

Since the Northwestern Lumbermen's Association suit there have been no further court actions charging retail associations with operating in restraint of trade.

### **Hardwood "Open Competition Plan."**

An interesting case with reference to the activities of lumber manufacturers' association work arose in connection with an injunction sought by the U. S. Attorney-General in the Federal Court in Memphis, Tennessee, on February 16, 1920, to prevent the American Hardwood Manufacturers' Association from continuing its so-called "Open Competition Plan." On March 16th, the Judge of the Federal Court granted a temporary injunction restraining the manager of statistics and 333 members of the Open Competition Plan of the American Hardwood Manufacturers' Association from any further activities under that plan because "Co-operation without competition means the destruction of competition-price fixing" and that the "latter is the state of the open competition plan."

The purpose of the plan as adopted by the Hardwood Manufacturers' Association of the United States<sup>1</sup> at the annual meeting January 31, 1917, was stated to be "to disseminate among members accurate knowledge of production and market conditions so that each member may gauge the market intelligently instead of guessing at it; to make competition open and above board instead of secret and controlled; to substitute, in estimating market conditions, frank and full statements of our competitors for the frequently misleading and colored statements of the buyer."

"This plan does not contemplate anything illegal or anything which might be developed into illegal acts. There is absolutely no agreement as to prices, either real or implied. There is no obligation, either real or implied, on the part of any member to reduce, increase, or change the character of his production in any other manner than he himself may think best. The plan will, however, furnish information to enable

<sup>1</sup> The plan was originally started by this association and was continued by the American Hardwood Manufacturers' Association when the former organization, with others, was merged into the American Hardwood Manufacturers' Association on January 18, 1918.

each member to intelligently make prices and intelligently govern his own production."

The plan was designed to cover all hardwoods, starting first with oak, and, as rapidly as the secretary could handle the details, to add other woods. The scheme called for six reports from each member on production, sales, shipments, stock, price lists, and inspection. The production, stock, and price-list reports were to be made monthly, and the sales and shipments reports daily. There was also an inspection service for the purpose of checking up grades at the mill.<sup>1</sup>

Monthly meetings were contemplated at points to be agreed upon by the contributing members of the association. As ultimately developed, group meetings were held at several different points tributary to the hardwood producing territory. The plan was first applied to oak only, the service beginning on March 1, 1917. On July 1, 1917, yellow poplar was added; on August 15, chestnut; on September 15, ash and basswood; and on March 1, 1918, all other hardwoods.<sup>2</sup>

In September, 1917, an attorney for the association, at the request of the Federal Trade Commission, filed a brief on the "open competition plan" with that body at the same time asking the Federal Trade Commission to make an examination of the methods employed in carrying out the purposes of the plan, in order that there might be no breach of the law.<sup>3</sup> No announcement from the Federal Trade Commission with reference to the brief was found, and it is assumed that no action was taken on it.

The granting of the temporary injunction on March 16, 1921, immediately stopped the collection, compilation, and dissemination of statistics, and also the group meetings. The injunction was made permanent on April 21, in agreement between the Government and the defendants, in order to hasten the decision of the case. The latter was carried to the United States Supreme Court, the brief of the association attorneys being filed on September 25, 1920, and the case coming up for hearing on October 20. The Court in March, 1921, asked for a re-argument of the case on April 11, but before the hearing, postponement was again made to October 10. On December 19, 1921, the Supreme Court handed down a decision in which it declared the "open competition plan" of the American Hardwood Manufacturers' Association illegal, six members voting in the affirmative and three in the negative.

The conclusion of the majority decision was as follows: "Convinced as we are, that the purpose and effect of the activities of the

<sup>1</sup> The text of the "Open Competition Plan" as approved at the annual meeting may be found in the *Hardwood Record*, Feb. 10, 1917, pages 24 to 27.

<sup>2</sup> See *American Lumberman*, March 2, 1918, page 51.

<sup>3</sup> See *Hardwood Record*, Sept. 10, 1917, page 20.

'Open Competition Plan,' here under discussion, were to restrict competition and thereby restrain interstate commerce in the manufacture and sale of hardwood lumber by concerted action in curtailing production and in increasing prices, we agree with the district court<sup>1</sup> that it constituted a combination and conspiracy in restraint of interstate commerce within the meaning of the Anti-trust Act of 1890 (26 stat. 209) and the decree of that court must be affirmed."<sup>2</sup>

The dissenting opinion held that, although the plan provided for co-operation in collecting and distributing information concerning the business of members and generally in regard to trade, and in so doing had formed a combination in trade, there was no evidence to support the contention that the organization was used or was intended to be used as an instrument to restrain trade.<sup>3</sup>

This decision of the Supreme Court created a feeling of uncertainty among the members of various trade associations, since there was doubt as to how far organizations might go in the collection, compilation, and distribution of statistical information and in other lines of work which have been developed in recent years.

On February 3, the Secretary of Commerce sent a communication to the Attorney-General of the United States requesting an informal expression from him as to the attitude of the Department of Justice on certain specific points which had to do with the rights of associations. The Secretary sought to learn whether an association, lawfully could (a) provide for its members a uniform system of cost accounting; (b) advocate and provide for uniformity in the use of trade phrases and trade names; (c) provide for standardization of quality and grades of product; (d) collect credit information; (e) arrange for insurance of various kinds for its members; (f) engage in co-operative advertising; (g) engage in the promotion of welfare work at the plants of its members; (h) handle all legislative questions that may affect the particular industry regarding factories, trades, tariff, taxes, transportation, employer's liability and workmen's compensation, and also handle rate litigation and railroad transportation questions, and (i) collect and compile statistics of production, consumption, stocks, wages, distribution, and sales price and then to turn them over to the Secretary of Commerce for distribution. The Attorney-General replied to the above communication on February 8, stating that there was no apparent objection to a standard system of cost accounting, but that "associations should be warned to guard

<sup>1</sup> U. S. District Court of Western Tennessee.

<sup>2</sup> The full text of the decision may be found in *American Lumberman*, Dec. 24, 1921, pages 50 to 52.

<sup>3</sup> See note, page 344.

against uniform cost as to any item of expense. I can see no objection to co-operative advertising designed to extend the markets of a particular article produced or handled by the members of an association, but when the several producers or dealers use uniform trade labels, designs, and trade marks it seems to me the inevitable result would be a uniformity of price. . . . I can see nothing illegal in the exercise of the other activities mentioned, provided always that whatever is done is not used as a scheme or device to curtail production or enhance prices, and does not have the effect of suppressing competition."<sup>1</sup>

The Attorney-General expressly stated that his views concerning what could or could not be done, lawfully, were tentative and that any unlawful practices which might arise through the exercising of any of the above phases of association work would be handled in the same manner as any other violation of the anti-trust laws.

The statement of the Attorney-General cleared up the following points with reference to association work.

1. That it is unlawful to adopt any uniform item of expense, such as stumpage.
2. That it is unlawful to curtail production, enhance prices, or to suppress competition.

There still exists some uncertainty with reference to the statistical activities of lumber trade associations and some definite action with reference to this phase of work may result from the efforts of the Secretary of Commerce to devise lawful ways and means by which the lumber industry may acquire and distribute the data which are essential to the successful conduct of the lumber business.

#### Other Association Cases.

*Southern Pine Association.*—In November, 1919, the Federal Trade Commission, at the request of the Department of Justice, started an investigation for the purpose of determining whether and to what extent the practices and usages of the several associations of lumber manufacturers in the United States were in conflict with the anti-trust laws. A general report was submitted to Congress on January 10, 1921, covering the activities of the National Lumber Manufacturers' Association, the Southern Pine Association, the West Coast Lumbermen's Association, the Western Pine Manufacturers' Association, the Northern Hemlock and Hardwood Manufacturers' Association, the Michigan

<sup>1</sup>The full text of the communications of the Secretary of Commerce and the Attorney-General may be found in *American Lumberman*, Feb. 18, 1922, pages 40 to 42.

Hardwood Manufacturers' Association, and the Chicago Retail Lumber Dealers' Association.<sup>1</sup>

On February 19 the Federal Trade Commission transmitted to the Senate Committee on Housing and Reconstruction a "Lumber Summary"<sup>2</sup> which later was transmitted to the Department of Justice. This summary dealt with certain alleged unlawful activities of the Southern Pine Association. On February 23, the Government filed in the United States District Court for the Eastern District of Missouri, a petition for a temporary and a permanent injunction restraining the Southern Pine Association, sixty-one corporate and sixty-nine individual defendants to the civil action, from urging, recommending, or suggesting curtailment or restriction of production; from printing and distributing any further issues of "trade barometers," "reports of operating time," or "monthly stock statements" or other charts, diagrams, or reports concerning the amount of southern yellow pine lumber produced; from issuing cost statements; and from holding further meetings of the association.<sup>3</sup>

*West Coast Lumbermen's Association.*—A report dealing with the conditions in the Douglas fir territory and outlining certain alleged unlawful price and curtailment activities, both of the loggers and lumber manufacturers, and reviewing the conditions in timber ownership and the relations of the lumber manufacturers to retail prices, was submitted to Congress under date of June 9, 1921.<sup>4</sup>

Among the charges made against the western operators were the following:

1. "The loggers and lumber manufacturers of the Douglas Fir region are organized for the purpose of taking concerted action on the prices of logs and lumber, supporting the prices so fixed by means of concerted restriction of production.
2. "The ownership of standing timber in the Douglas fir region, the chief source of the Nation's reserve supply, is concentrated in the hands of a comparatively few strong concerns.
3. "The relation between the fir log and lumber markets is such that ordinary manufacturing profits tend to be

<sup>1</sup> This report appears in full in *Lumber*, Jan. 17, 1921, pages 19 to 23.

<sup>2</sup> The text of the "Lumber Summary" may be found in *Lumber*, Feb. 28, 1921, pages 62 to 66b.

<sup>3</sup> Definite action on this case had not been taken at the time this volume went to press.

<sup>4</sup> The full text of this statement may be found in *Lumber*, June 17, 1921, pages 30 to 32 and 51 and 52.

absorbed in the price of logs and the valuation of timber, particularly on falling wholesale markets.”

4. That when the Douglas fir loggers and manufacturers failed to prevent Canadian log importations which were threatening to defeat an advance in price in 1919, the British Columbia loggers became affiliated with the American association and adopted the latter’s prices.
5. That “in addition to a similar exchange between fir and southern pine manufacturers, prompt notice of price action is given each other by the fir manufacturers and those of western pine, for the purpose and with the effect of securing harmonious action by both groups.
6. “Despite the fact that retail prices on lumber in January, 1921, had not been reduced proportionately to the decline in wholesale prices, the manufacturers joined hands with the retailers in an advertising campaign to revive buying which, if successful, will tend to prevent such a reduction.”

A temporary or permanent injunction against the continuance of these alleged acts by the association was not asked for at the time this statement was filed and, so far as known, no definite action has been taken with reference to it. It is the assumption that the Government rested its case until the decision of the “open competition case” had been rendered by the Supreme Court.

*Western Pine Manufacturers’ Association.*—On February 15, 1922, the Federal Trade Commission submitted a report to Congress dealing with the activities of this association.<sup>1</sup> In this report, the Federal Trade Commission charged that the association was organized and conducted for the primary purpose of agreeing on the price of lumber. The Commission also charged that, in periods of depression, association members have resorted to regulation of production to maintain lumber prices; that association members have been prominent in the maintenance of a box bureau through which prices of box material have been fixed by concerted action; that in order to make uniform prices effective, a common freight-basing point has been adopted; that the association has attempted to standardize discounts from official prices; that there has been active co-operation between the association and the West Coast Lumbermen’s Association with the purpose and effect of harmonious action on prices and production; and that there has been active co-operation between the above association and pine producers in California with the purpose and effect of similar price action on shop lumber.

<sup>1</sup> The text of this report may be found in *Lumber*, Feb. 17, 1922, page 23.

Further Government action on the above cases is looked forward to with great interest not only by the lumber trade associations but also by all other trade organizations, since an adverse decision on the questions at issue would undoubtedly necessitate not only a radical readjustment of the relations which various associations bear to each other, but also their reorganization on a different basis.

Pages 310 and 340. The American Hardwood Manufacturers' Association was disbanded, as a result of a decision of the United States Supreme Court, since it was evident that it could not continue to function along the lines for which it had been organized.

On June 15, 1922, hardwood lumber manufacturers organized The Hardwood Manufacturers' Institute, following conferences with Department of Commerce and other government officials concerned with the activities of trade associations.

The objects and purposes of the new organization as expressed in its constitution, are: (a) To secure and disseminate a full understanding of the facts and conditions concerning and affecting the hardwood industry; (b) to provide and adopt and assist in the adoption and establishment of measures designed and intended to provide and establish, (1) uniform standards and improved methods of manufacturing and marketing hardwood products, (2) uniform standardized nomenclature for the industry, (3) standardized rules for the grading, inspection, and certification of lumber and forest products, (4) an inspection service for the indorsement and administration of said rules, adequate to meet all needs therefor, (5) appropriate and efficient means for guaranteeing to purchasers and the public, the integrity of grades, the quality and quantity of lumber, and the improvement of trade practices; (c) to acquire, preserve and disseminate information respecting the industry; (d) to enlist the cooperation of the consumers in promoting the mutual interests of producers and consumers; (e) to adopt such means as will promote the wisest utilization and the prevention of waste, thereby serving the cause of conservation of our timber resources.



## CHAPTER XVI

### LUMBER GRADES AND INSPECTION

THE necessity for some scheme of lumber classification, by grades, as a basis of trade and for the purpose of fixing prices for the products was recognized as of great importance even in the early days of the industry.<sup>1</sup> During the last forty years it has been one of the chief lines of activity of associated effort among lumber producers.

#### FORMULATION OF RULES FOR THE GRADING AND INSPECTING OF LUMBER

##### Objects.

Grading and inspection rules have been formulated for the purpose of describing the relative worth which a given lot of lumber possesses in order that a basis may be established by means of which the utility of lumber for specific purposes can be determined and its sizes accurately and intelligently expressed.

Although stability is desirable in grading and inspection rules they ultimately become antiquated and are discarded unless they conform to the gradual changes which take place in trade customs and in methods of manufacture. Present-day rules, therefore, are more comprehensive than those first formulated because there have been many changes in the requirements of the consumers, both as to quality and size, and because there has been a marked decrease in the quality of raw material which is manufactured into lumber. For example, in the late "sixties," southern yellow pine operators found it possible to market only three grades of heart lumber because the market was limited and the highest-quality lumber brought only a relatively low price. When the territory in which the product was marketed began to expand and production increased, there arose a demand for lumber which could be sold at a price below that received for the best grades. Utilization gradually became more intensive and to-day southern pine

<sup>1</sup> The first known printed rules for lumber grading were those published by Swan Alversdon of Stockholm, Sweden, who in 1764 defined four grades of Scandinavian pine, namely, "Best," "Good," "Common," and "Culls."

operators harvest from an acre of ground fully five times as much material as would have been taken from the same acre fifty years ago. During this period the rules for the inspection of southern yellow pine have undergone a gradual change and now include many classes both of rough and finished material.

### **Basis of Rule Making.**

The products which result from converting logs into sawed materials range in quality from perfect to worthless stock. In formulating and changing grade specifications, manufacturers have been guided largely by the defects, which are characteristic of a given kind of timber; by the methods of manufacture which are feasible; by the added cost of handling and assorting lumber which additional grades necessitate; by the difficulties confronting the retailer in handling a larger assortment of grades; by the ultimate uses of the product, as influenced by strength, appearance, durability, and size; and by the savings in raw material which may be effected by reducing the minimum dimensions of standard stock.

Softwoods which are used chiefly for general construction purposes are graded from the standpoint of the use of the piece as a whole; although examples may be cited where this is not the case, such as stock used for shop, box-board, novelty, and cooperage purposes.

Hardwoods, on the other hand, are largely re-manufactured by the wood-using industries which reduce the original board to smaller dimensions. Clear stock, therefore, can be secured from pieces which in part are defective and which in softwoods would be classed in the lower or lowest grades.

Quality is the chief consideration in grade making although minimum sizes also are indicated. The grade of a given piece of sawed product is determined by the number, size, and location of officially recognized visible defects which may be present in the piece. These defects include knots, both sound and unsound, knot holes, sap either stained or bright,<sup>1</sup> shake, wane, rot, rotten streaks, red heart, peck, pitch pockets, splits, shake, worm holes, rafting-pin holes, seasoning checks, planing-machine defects such as chipped, torn, or loosened grain, and defects in manufacture such as thick and thin spots which cause "skips in dressing." All of these defects are not found in all species, and also there may be a great difference in the quality of a given species, even in the same region. The defects enumerated, however, are those recognized by the various grading rules as being common to sawed products.

The grain and density of wood may be important factors in classify-

<sup>1</sup> In some species bright sap is no defect.

ing dimension and timbers for use where maximum strength is essential. The latter factors were first recognized officially in January, 1915, when the Southern Pine Association adopted the so-called "density rule" for the grading of structural timber. The West Coast Lumbermen's Association adopted similar rules for Douglas fir in August, 1919. These rules, prepared in co-operation with the United States Forest Service, were based on the number of rings per inch, the per cent of summer wood present, and the size and location of knots and other allowed defects.

Grading rules are not an absolute guide to grade determination since the specifications define only the coarsest pieces that may be admitted to the grade.

It is possible to classify a large per cent of the lumber in accordance with printed specifications, but there always remains a small per cent<sup>1</sup> of the product known as "line boards," or those which may represent a very high quality for one grade or the lowest quality of the next higher grade, the classification of which can not be covered by written specifications.

Since printed rules are not an absolute guide to grading practice, an inspector rarely, if ever, becomes competent solely by study. He must learn his trade through the actual handling of, and contact with the product, training his eye to recognize combinations of defects which are admissible in given grades and using printed rules chiefly for checking disputed points. A keen observer may become proficient in grading the general run of boards within a few weeks, but it may require several months' time in which to acquire sufficient knowledge to grade "line boards" correctly. Even experts, equally competent may fail to agree on the proper classification of a small per cent of the product. This is recognized by the inspection departments of associations in settling "off-grade" claims made against shipments, by accepting as correct the original inspection provided the re-inspection shows that not more than 3 or 4 per cent of the total number of pieces are below grade.

No effort is made in this volume to deal with the grades and the classifications of specific rules since this can best be undertaken in connection with a field study at a manufacturing plant.<sup>2</sup>

<sup>1</sup> Often from 3 to 5 per cent.

<sup>2</sup> The reader is referred to the following publications for details with reference to specific rules. Lumber Inspection Rules, 1921, compiled by Lumber Inspection Rules and for sale by American Lumberman, Chicago, Ill.; and How Lumber is Graded, by H. S. Betts, U. S. Dept. of Agriculture, Washington. Circular 64, March, 1920.

## STATE RULES FOR GRADING AND INSPECTING LUMBER

The formulation and enforcement of grading rules and inspection has developed largely through private endeavor, although in a few states an attempt has been made to regulate lumber inspection by law. As early as 1783, Massachusetts passed a law providing for the annual election in every town and district of the Commonwealth of "Surveyors and Measurers of boards, planks, timber, and slit work, and Surveyors of shingles, clapboards, staves, and hoops. . . ." <sup>1</sup> This law also prescribed the fees to be charged by the Surveyor. The chief specifications with reference to sawed products referred to pine boards for export which called for square-edged pieces not less than 1 inch in thickness and not less than 10 feet long. This law was revised in 1858, at which time grading rules were adopted for those soft woods and hard woods which were produced in, or imported into the State. These laws were popularly known as the "Boston Survey" and in modified form are still in force for such lumber as enters Boston by water.

The rules formulated under the Maine state law were designed for white pine because it was then the chief sawed product of the lumber industry of the state. Defebaugh states that, "In a general sense it can be said that lumber grading or inspection for the entire country originated in Maine." <sup>2</sup> However, the Maine system was not adopted by the industry at large.

In 1900 a bill was prepared for introduction into the Georgia legislature providing for a state department of lumber inspection, which had the support of some of the lumber interests of the state. The condition in Georgia which led to the proposal of such a department was the diversity in the quality of product placed on the market by local operators. There were many small, unorganized mills which sold poorly manufactured and carelessly graded lumber as standard grades, with the result that the lumber from that state was unpopular in the outside markets. It was hoped that state rules and state inspection would remedy this evil, but the opposition to state legislation on this subject became so strong that the bill was not enacted into law.

The chief fault with grades and specifications established by legislative acts has been that they could not prevent private agreements concerning the sale and purchase of lumber and consequently state inspection often was ignored. This is doubly true at the present time, since lumber often is inspected before it leaves the mill. In Massa-

<sup>1</sup> See History of the Lumber Industry in America, Vol. II, by J. E. Defebaugh, published by American Lumberman. Chicago, Ill., 1907, page 205.

<sup>2</sup> See History of the Lumber Industry in America, Vol. II, page 107.

chusetts, which has one of the best state systems, only a small per cent of the lumber used within the state is inspected by state officials.

The early inspection rules formulated in the various producing regions were very simple in character and provided for two or three qualities only. Within recent years, however, the grades have multiplied and the rules have been amplified to meet modern conditions.

#### PRIVATE AND ASSOCIATION RULES FOR GRADING AND INSPECTING LUMBER

In most sections, rules for grading and inspection developed locally, fostered by individual firms or groups of firms, chiefly wholesalers, who were located in the more important distributing centers, since they had a higher degree of co-operation than the producers. Shipments to these markets usually were handled in cargo lots purchased "mill run" from the sawmills by the wholesale distributors. Each distributing center sold chiefly to the local trade and the rules for grades and inspection were adapted to that end. As a consequence, there grew up in the various distributing centers standards of quality and size, which were not in conflict because buyers seldom had occasion to trade in more than one market.

When the demand for lumber increased, due to the rapid development of the agricultural areas, the importance of the great wholesale distributing centers accessible to water transportation began to wane, because new forest areas were being opened up which were not tributary to water transportation. Rail transport direct from mill to retail buyer increased at a rapid rate, and the field open to the lumber shipper was greatly expanded. The lumber producer and the buyer were no longer limited to one market. Great confusion arose in connection with this extension of the market because of the different standards of quality and size in the various regions. Further, some producing sections in a given region, such as the southern yellow pine, because of their isolation, had developed standards at variance, one with the other, so that certain products, especially mill work from one region could not be used interchangeably on a given piece of work, with the same class of product from another section in the same region.

The inability of the individual producer to bring about uniformity in grades and inspection early was recognized. No single producer or small group of producers could have secured the adoption of their rules in other sections because operators were averse to altering their accustomed practices. Further, no set of rules could be effective unless some form of mill inspection could be instituted which would ensure uniform application of the grades and specifications. Also the

maintenance of an efficient corps of inspectors would be possible only by associated effort on a reasonably large scale.

The first efforts of lumber manufacturers to formulate grading rules to be applied to mill shipments were made in the late "eighties" of the last century, as a result of the growing dissatisfaction with inspection at distributing points, and also because of the change in manufacturing procedure, due to the rapid increase in planing mill facilities at sawmill plants. This was especially true of southern yellow pine operators who, in seeking outside markets for their products, found it advantageous to deal directly with the retail trade in the prairie states. The present manufacturers' rules for most of the softwoods and hardwoods were formulated during the early "nineties" at which time permanent manufacturers' regional associations were formed.

### **Southern Yellow Pine.**

The yellow pine lumber of the South is graded under the rules of one of the four following associations, namely, the Southern Pine Association, the Georgia-Florida Saw Mill Association, the North Carolina Pine Association and the Gulf Coast Classification.

*Southern Pine Association Rules.*—The Southern Pine Association rules cover lumber, timbers, laths, shingles, and other standard stock manufactured by its members, whose mills are located in the states of Alabama, Arkansas, Florida, Georgia, Louisiana, Mississippi, and Missouri. The association states that, "Fully 90 per cent of the output of southern yellow pine lumber in the states named is graded and classified according to the specifications of the association." The rules of this association are based on those formulated by the Southern Lumber Manufacturers' Association which was the first large association in the southern yellow pine region. The latter organization drew up its first rules in September, 1890, at which time specifications were provided for flooring, ceiling, boards, fencing, and dimension.<sup>1</sup> These have been amplified from time to time by succeeding associations, and now include many kinds of finished products and rough lumber. The Georgia-Florida Saw Mill Association uses these for grading lumber and mill work. The Southern Pine Association issues special rules for the grading of car material; bridge and trestle timbers; and also for structural timbers by the so-called "density rule."

*The Interstate Rules.*—These were first formulated by the Southern Land and Timber Association in 1883 under the title of "Classification and Rules of Inspection" known generally as the

<sup>1</sup>A local association in the Missouri and Arkansas territory formulated rules in 1888.

“Savannah Rules of 1883,” and were confirmed in 1899 and amended in 1902 by the Georgia Sawmill Association. They were again changed in 1905 by the Georgia-Florida Sawmill Association. They are now used for grading dimension and timbers by the present association, also by the North Carolina Pine Association, and several local exchanges and associations along the Atlantic Coast.

*The North Carolina Pine Association Rules.*—Previous to 1888, there were no official rules in the territory now covered by this association, namely, Virginia, North Carolina, and South Carolina. Lumber was graded and inspected by local specifications formulated by firms in the wholesale markets, chiefly Norfolk and Baltimore. On May 20, 1888, the Carolina Pine Lumber Association formulated a set of rules for “The Inspection of Rough North Carolina Pine.” These rules were too radical a departure from the informal system previously in use and were not generally observed.

In November, 1890, the North Carolina Pine Lumber Company, organized the previous year, revised the 1888 rules of the Carolina Association. This revision was adopted and observed by the larger mills of the region which handled kiln-dried lumber. These were modified in 1892 and continued without change until January 1, 1898, when a new set of rules formulated by the North Carolina Pine Association, organized in 1897, became effective. The first rules covering dressed lumber manufactured in this territory were formulated and adopted in January, 1903. In November, 1905, the association adopted the Interstate Rules of 1905 for the classification and inspection of longleaf yellow pine timbers. These were of special use to South Carolina pine operators who were the chief producers of this class of stock among the North Carolina Pine Association membership. With the exception of a few minor changes, the 1903 rules for rough and dressed lumber remained in force until April 1, 1906, when a new set of “Rules for the Classification and Inspection of North Carolina Pine” became effective. These were ambiguous in some respects and in order to clarify the specifications they were again revised, and became effective September 1, 1911. These, with minor changes, are the ones in use to-day.

*Gulf Coast Classification.*—Among the early association classifications for export southern yellow pine was that of the Gulf Coast Yellow Pine Export and Manufacturers’ Association adopted on December 10, 1892. This association later went out of existence, and in 1907 the Gulf Coast Lumber Exporters’ Association was organized, one of the purposes of which was the establishment of a uniform classification for southern yellow pine stock shipped from Gulf points. The rules drawn up in 1907 were revised in 1908 and again in 1910. In 1912 the association passed out of existence but the 1910 rules are still in use, having been

adopted in 1915 by the Southern Pine Association as its standard export classification.

### **Eastern White Pine.**

Rules for the inspection and classification of white pine lumber were among the first, if not the first, developed for any species in the United States. The early rules of the Albany, New York, wholesale market are credited with being the chief single influential guiding factor in the formulation of succeeding ones for this wood.

Among the early rules of inspection for white pine were those in effect in Penobscot County, Maine, as provided by the law of 1832; at Williamsport, Pennsylvania; Burlington, Vermont; Buffalo and Tonawandas, New York; in the Saginaw Valley in Michigan; and at Chicago, Illinois. All of these local specifications were developed by some association which altered them from time to time to meet the changing market conditions. They were based largely on the grading of lumber cargoes shipped to the large wholesale distributing centers. Up to 1890 the only printed guide to grading and classification used by rail shippers in the Lake States was what was known as the "Meginn Rules for Lumber Inspection," prepared by James Meginn an inspector in the Chicago wholesale yards. They contained simple and general specifications for flooring, ceiling, siding, finishing boards, and dimension.

In northeast Georgia, where limited quantities of white pine are manufactured, there have never been any local rules for grading white pine. The product is sometimes graded by agreement with the purchaser on the basis of the yellow poplar specifications. When this is not done the rules of the Northern Pine Manufacturers' Association are generally used.

*Northern Pine Manufacturers' Association Rules.*—One of the first steps taken by the Mississippi Valley Lumbermen's Association after its organization in 1890 was to make provision for a system of uniform classification for the lumber output of the mills operating in the Mississippi Valley. A committee on inspection reported a set of rules at a meeting held on September 24, 1890, and after discussion the association adopted the proposed rules as the standard for grading. The great need for uniform standards was recognized since the markets for pine from that region were expanding and lumber shipments from various sections were entering the same markets. Progress in uniform inspection was slow for several years, but at the annual meeting on February 26, 1895, the Committee on Uniform Grades reported the "White Pine Inspection Rules" which had been prepared during the few preceding months and these were adopted by the meeting. These rules were so carefully drawn,



that they were adopted by the Northern Pine Manufacturers' Association, at the time of organization in 1906, and have remained in use continuously since that date with such minor revisions and such additions as have been necessary to keep them in line with changing market conditions and timber supply.

*Tonawanda Rules.*—The first Tonawanda Market grading rules, formulated by the wholesale interests, were in use prior to the Civil War. The present rules have undergone many changes since that time for in 1862 three grades only were recognized while to-day there are numerous classes of products each of which is divided into several grades.

The present grading rules "are essentially general in their character, no technically detailed grading rules ever having been published covering Tonawanda grades. The large number and consequent close similarity of the different Tonawanda grades necessitate such fine distinctions in describing them that the compiling of a clearly understandable and easily interpreted set of grading rules is obviously difficult, the grading of so-called 'line boards' . . . being left as the result of long-established practice to the judgment of grading inspectors."<sup>1</sup>

#### **Western White Pine** (*Pinus Monticola*).

This wood, known in the markets as Idaho white pine, is graded under rules formulated by the Western Pine Manufacturers' Association. On April 15, 1903, the Western Pine Shippers' Association first adopted grading rules for this species based largely upon of the those Mississippi Valley Lumbermen's Association, which were followed until February 2, 1910, when a modified set more nearly adapted to western white pine were drawn up by the Bureau of Grades of the Western Pine Manufacturers' Association. The rules in use at the present time are those revised and made effective on March 1, 1917.

#### **Western Yellow Pine** (*Pinus ponderosa*).

Lumber of this species, except that produced in California, is graded under the rules of the Western Pine Manufacturers' Association. The California product, known as California white pine, is graded under the rules of the California White and Sugar Pine Manufacturers' Association adopted June 2, 1916, and revised July 19, 1918. These conform, in general, to the scheme of inspection in use by the Northern Pine Manufacturers' Association. Previous to 1916 the inspection rules of

<sup>1</sup> See, White Pine Standard Grading Rules, published under the direction of the White Pine Bureau, Minneapolis, Minn., 1917. So far as known this marks the first appearance, in printed form, of the Tonawanda rules, of the White Pine Association of the Tonawandas.

the California Sugar and White Pine Agency (a selling exchange) were largely used.

### **Sugar Pine.**

The greater part of the sugar pine lumber output is produced in California and graded under the rules of the California White and Sugar Pine Manufacturers' Association rules of July, 1918. Previous to 1916 the rules of the California Sugar and White Pine Agency were used extensively.

### **Norway Pine.**

Lumber of this species, manufactured in the Lake States, is graded under the rules of the Northern Pine Manufacturers' Association for the inspection of northern pine.

### **Lodgepole Pine.**

Only a limited quantity of lumber is produced from lodgepole pine and special rules have not been formulated for its inspection. Lumber cut in the Inland Empire is graded in accordance with the rules of the Western Pine Manufacturers' Association. In the Rocky Mountain region the output is chiefly from small mills which do not use any standard system of inspection.

### **Douglas Fir.**

Among the earliest association grading rules for the inspection of Douglas fir were those formulated in 1893 by the Lumber Manufacturers Association of the Northwest. These rules covered both rough and dressed stock not only in Douglas fir but also in red cedar and Sitka spruce. Specifications for red cedar shingles also were included.

Before the formulation of these rules the grading practice was not standardized and much confusion existed. In an editorial comment in a trade journal<sup>1</sup> in 1890 there appeared the following statement with reference to Pacific Coast conditions. "At present the inspection of lumber is very lax. Each mill has its own grade and uniformity is a desideratum that is longed for by many. Until the last two years, the mills put their lumber into two grades, that which was clear and that which was not. Gradually the need of some basis for prices was recognized until now the grades are divided into No. 1 and No. 2, some manufacturers making a third grade, all under these grades being classed as

<sup>1</sup>The Mississippi Valley Lumberman, Nov. 21, 1890, p. 14.

rough, corresponding to our eastern common, though no further subdividing of the common is in vogue."

The first published Domestic Cargo Rules for Douglas fir were those in use by the Central Lumber Company, which appeared in the Pacific Lumber Trade Journal of February, 1897.<sup>1</sup>

At present, Douglas fir is graded under three separate rules, one for rail shipments, one for domestic cargo shipments, and one for export cargo shipments. The rail rules have been formulated and issued by the West Coast Lumbermen's Association and both of the cargo rules by the Pacific Lumber Inspection Bureau, which though separate organizations, are closely affiliated as the Inspection Bureau handles the inspection work of the association. The formulation of the present rail rules dates from March 29, 1901, at which time the newly organized Pacific Coast Lumber Manufacturers' Association adopted "Rules for Grading" rail shipments and took steps to organize a cargo branch of the association presumably to formulate grades and issue price lists, for "heretofore prices and grades have been made by San Francisco dealers."

Cargo inspection was unsatisfactory until 1903, when a cargo branch of the Pacific Coast Lumbermen's Association known as the Pacific Lumber Inspection Bureau, was organized which formulated rules for water shipments. This Bureau was incorporated in 1907 as an organization separate from the manufacturers' association. In 1911 three associations of manufacturers in the Pacific Northwest<sup>2</sup> merged into one association, under the name of the West Coast Lumber Manufacturers' Association, and the Inspection Bureau then took over the work of the combined organization. The same relations were continued when the manufacturers' association was reorganized as the West Coast Lumbermen's Association in 1915.

The limited quantity of Douglas fir produced by manufacturers in the Inland Empire is graded in accordance with the rules of the Western Pine Manufacturers' Association.

## Hemlock.

*Eastern Hemlock.*—The product of mills in New England, New York and the Middle Atlantic States is graded by local rules which so far as known have not been compiled and published officially. In New York the grades formulated by the Northern Hemlock and Hardwood Manufacturers' Association are sometimes used. The Massachusetts State

<sup>1</sup> Formerly published in Seattle, Washington.

<sup>2</sup> The Pacific Coast Lumber Manufacturers' Association, the Oregon and Washington Lumber Manufacturers' Association, and the Southwestern Washington Lumber Manufacturers' Association.

Law for the Inspection of lumber known as the "Boston Survey" defines two grades of Pennsylvania hemlock.

Among the first published rules for hemlock lumber manufactured in the Lake States were those adopted by the Northwestern Hemlock Manufacturers' Association on June 6, 1896, at the time of organization of this association. These provided for two grades of boards and two grades of dimension and were very simple in character. On July 7, 1897, new rules were formulated in an effort to bring about a greater uniformity throughout the region. These rules, which provided for three grades each, of boards and strips, and of dimension also were adopted by the Mississippi Valley Lumbermen's Association with whom arrangements were made for supervising the mill inspection.

The Northwestern rules were revised in 1906 and with minor changes are in force to-day, having been accepted by the Northern Hemlock and Hardwood Manufacturers' Association during the same year. They are published as the standard for the Northern Pine Manufacturers' Association.

*Western Hemlock.*—The lumber from this species is graded under the rules adopted by the West Coast Lumbermen's Association for rail shipments and under the Pacific Lumber Inspection Bureau rules for foreign and for domestic cargo shipments.

## Spruce.

*Eastern Spruce.*—The only published rules for the grading of spruce lumber in New England are those for "Vermont spruce" appearing in the Massachusetts state law for the inspection of lumber, known as the "Boston Survey." This rule provides for four grades, namely, Clear, No. 1, No. 2, and No. 3. However, size rather than quality is the chief basis for assorting spruce lumber in New England.

A local rule, unpublished, is used for grading lumber in northern New York, quotations in the New York city markets on lumber from this region being made on four grades known as No. 1 and 2 Clear, No. 2, No. 3, and Mill-run (mill culls out).

Appalachian spruce is graded on the basis of the Spruce Inspection Rules formulated by the Spruce Manufacturers' Association, which became effective January 25, 1910, and which provide for five grades known as Firsts and Seconds, Selects, Merchantable, Box, and Mill Culls. These rules also were adopted by the New York Lumber Trade Association on April 13, 1910, as the standard for West Virginia spruce.

The spruce output of the Lake States is inspected in accordance with the rules of the Northern Pine Manufacturers' Association.

*Sitka Spruce.*—The rules of the West Coast Lumbermen's Associa-

tion and the Pacific Lumber Inspection Bureau are the standard for inspecting this wood in the region west of the Cascades.

*Engelmann Spruce.*—The output of the Inland Empire is graded under the rules of the Western Pine Manufacturers' Association.

### Larch.

*Tamarack.*—The product of the Lake States is graded in accordance with the rules of the Northern Pine Manufacturers' Association. No published rules for this species are in use in other sections.

*Western Larch.*—Larch lumber from the Inland Empire is graded in accordance with the rules of the Western Pine Manufacturers' Association. The larch output of western Canada is inspected by rules formulated by the Mountain Lumber Manufacturers' Association.<sup>1</sup>

### Cypress.

The first official grading rules for rough cypress were those adopted in the early "nineties" by the Southern Cypress Lumber and Shingle Association, and for dressed lumber those adopted by the same association on February 13, 1893. They provided for five grades of rough lumber, four grades of flooring, five grades of bevel siding, and four grades of shingles. These rules, with some modifications, were used until the formation of the Southern Cypress Manufacturers' Association in May, 1905. During this period apparently but little was accomplished in the standardization of dressed sizes, for at the organization meeting in 1905 one of the members in speaking of the matter of gauges for dressed stock said: "We do not find any uniformity in thickness. . . ." At the annual meeting on May 15 and 16, 1907, several important changes were made in the rules in order to eliminate ambiguous phraseology and to enable the association to make the interpretation more uniform.

Other minor changes were made in 1908 and in 1913. In 1915 a complete revision of the association classification and grading rules was made, which became effective January 1, 1916. This revision chiefly affected retail yard grades which originally were modifications of grades designed primarily for factory purposes and which no longer met retail requirements. The cypress association about this time launched an aggressive campaign to increase the use of cypress in the general construction field and the changes were desirable to meet the needs of the new markets. Minor changes in grade nomenclature and specifications were made in 1921.

<sup>1</sup> The headquarters of this association are in Nelson, British Columbia.

The National Hardwood Lumber Association at its annual meeting on June 15, 1917, adopted an independent set of grading rules designed to serve both the retail and factory trade. These rules differ somewhat in grade terminology and specifications from those of the cypress association, having some features common both to hardwood and softwood grades.

The cypress association grades were adopted as the standard for the inspection of cypress by member mills of the American Hardwood Manufacturers' Association, at the time the latter was organized.

### **Redwood.**

Redwood lumber, for many years, was graded chiefly at wholesale markets in accordance with local rules. A change in procedure, in so far as Humboldt County mills were concerned, was put into effect in 1902, when the Humboldt Lumber Manufacturers' Association appointed an official inspector for the purpose of grading lumber at the mills instead of at San Francisco.

The rules in use to-day are those adopted on April 5, 1917, by the California Redwood Association.

### **Cedar.**

There are no official rules for grading eastern red cedar, the product usually being sold log run. The only ones for southern white cedar are those prepared for special products such as "boat boards," for which the Navy Department has issued specifications.

*Port Orford Cedar.*—The Pacific Lumber Inspection Bureau issues specifications for several grades which constitute the chief guide for inspection.

*Western Red Cedar.*—This is graded chiefly under the rules and specifications of the West Coast Lumbermen's Association, and the Pacific Lumber Inspection Bureau Domestic List No. 7. A very limited amount, produced in the Inland Empire, is graded by the Western Pine Manufacturers' Association rules.

### **Hardwoods.**

More controversy has centered about the grading and inspection of hardwood lumber than about any of the softwoods. Previous to 1886, there were no official rules recognized for the inspection of hardwoods, the product being sold "mill run" or under special contract to jobbers, wholesale buyers, and large consumers.

Soon after its formation, on December 14, 1886, the New York Lun-

ber Trade Association adopted official rules for the inspection of the more important hardwoods handled in that market.

The first important step taken to standardize hardwood grades was made at a meeting held in Chicago, Illinois, on April 8 and 9, 1898, at which time preliminary steps were taken to organize the National Hardwood Lumber Association by wholesalers and manufacturers who were in business chiefly in the northern and central hardwood regions, although there were some representatives from the southern region. The meeting was called primarily for the purpose of organizing to secure uniformity of inspection for hardwood lumber. The meeting proposed "Rules of Inspection" covering the various commercial hardwoods and also for southern yellow pine. At the first annual meeting of the association held on May 5 and 6, 1898, the hardwood rules were adopted. The proposed rules for yellow pine were discarded and those of the Southern Lumber Manufacturers' Association substituted for them. The rules of the Southern Cypress Lumber and Shingle Association also were made the official ones for cypress inspection.

These hardwood rules were acceptable neither to southern lumber producers nor to some operators in the central territory because it was felt that they discriminated against southern manufacturers in favor of northern and eastern wholesale interests. As a consequence, an organization known as the Mississippi Valley Hardwood Lumber Manufacturers' Association was founded on May 10, 1898, to formulate hardwood rules from the manufacturer's viewpoint. Rules for the grading and inspection of hardwood lumber were later drawn up and adopted by the association. In 1902 the association was re-organized under the name of the Hardwood Manufacturers' Association of the United States. The field of activity was extended to include an inspection department, with a corps of inspectors maintained by the association for the purpose of regularly visiting each member mill to regulate grades and also to make official inspection and report on claims made against shipments by members.

The inspection rules formulated by the two above-mentioned associations caused considerable confusion in the hardwood trade and various unsuccessful attempts were made to harmonize them previous to the consolidation of the Hardwood Manufacturers' Association of the United States, the American Oak Manufacturers' Association, and the Gum Lumber Manufacturers' Association on January 18, 1918, under the name of the American Hardwood Manufacturers' Association, when steps were taken looking towards the unification of hardwood inspection. This was finally accomplished in conference, by the adoption on the part of the new organization of the rules for inspection formulated by

the National Hardwood Lumber Association. The latter association is now the sole rule-making body, the manufacturers' association, however, having representation on the Inspection Rules Committee of the National Association. The latter organization also retained its bonded inspection service. The American Hardwood Manufacturers' Association retained its mill inspection department. Its activities relating to arbitration concerning lumber in dispute are confined to those cases in which the consent of the shipper and consignee have been obtained.

#### ENFORCEMENT OF RULES FOR THE GRADING AND INSPECTION OF LUMBER

Rules for the grading and inspection of lumber are of little value unless they receive a common interpretation by those using them and unless they are accepted by a clientele sufficiently large to make their adoption an assured success. Many of the early grading rules, even though accepted by some operators, or others interested in them, failed in the accomplishment of the purpose for which they were formulated because they were not uniformly applied. Each mill placed its own interpretation on the specifications with the result that there was a wide range in the quality of what was supposed to be a uniform grade. Intentional deviation from the standard sometimes was practiced by shippers who, in dull periods, "sweetened" their grades by the addition of material of a better quality than called for by the specifications. This virtually was an indirect method of price cutting, since the buyer secured stock of a higher quality than he purchased. On the other hand, when trade was brisk and the demand was strong grades sometimes were "robbed" by keeping the quality below the minimum. This practice was possible because, on a rising market, complaints against off-grade shipments were few in number.

One of the first association efforts to make grading and inspection uniform was taken by the Southern Lumber Manufacturers' Association which, in 1891, amended its by-laws so as to provide "a chief inspector, with one or more assistants who shall be located centrally as regards the lumber markets." The plan was designed to cover the supervision of the grading force at member mills, through periodic visits of association inspectors whose duties would be to bring about uniformity of grading by educational means. This scheme was not productive of satisfactory results, since adequate personnel was not available to make the work effective. In 1897 a Bureau of Uniform Grades was organized within the association to handle inspection work and grading rule revisions. This Bureau attempted an inspection service in 1898 which was not successful because of the lack of system and organization. In



May, 1899, however, the work was fully organized under a Chief Inspector, the territory being divided into districts with an inspector making regular visits to member mills. Facilities also were provided for inspecting claims made against members for off-grade shipments.

A similar plan had been inaugurated in the territory of the Mississippi Valley Lumber Manufacturers' Association in 1895. Analogous methods of securing uniform interpretation of grading and inspection rules by member mills are now in use by nearly all manufacturers' associations.

On the West Coast inspection is handled by an organization not connected with the manufacturers' association, although affiliated with it. The West Coast Lumbermen's Association maintains an "Associated Bureau of Grades" which is the rule-making agency of the organization and is responsible for promoting new ideas on rules and specifications. The inspection work is handled by the Pacific Lumber Inspection Bureau, an incorporated association, the shareholders of which are the various mills which wish to use its service. Members of this Bureau are chiefly members of the manufacturers' association, although some are members of one and not of the other. This Bureau publishes grades and specifications for foreign and domestic cargo shipments, in addition to providing the inspection service. The territory is divided into various districts covering Oregon, Washington, and the Province of British Columbia with a supervisor in charge of each district, who is responsible to a chief inspector located at the headquarters of the Bureau. The actual work of inspection is done by local Bureau inspectors who submit sworn certificates of grade, countersigned by the district supervisor, to the shippers, who, in turn, forward them to the consignee. The cost of inspection is charged against the mill for which the inspection is made.

The National Hardwood Lumber Association and various local Lumber Exchanges offer similar forms of inspection service in the larger market centers to buyers and shippers. The National Association, under its Bureau of Grades, has licensed bonded inspectors in many of the important centers whose services are available for the inspection of lumber shipments and also for the settlement of grade disputes. The certificates of inspection issued by this association usually are accepted, without question, as proof of quality and count in transactions between buyer and seller. This association now controls hardwood inspection in practically all markets. The expense of the service is met by standard fees, which are paid to the inspection force.

Softwood inspection in the wholesale markets of New York city is largely in the hands of two classes of inspectors, namely, those in the employ of the Public Service Commission, the railroads, retail yards, creosoting plants, and wholesale dealers; and those who are independent or consulting inspectors.

The inspector's survey is not necessarily final except in the case of the Public Service Commission and the railroads, since one of the interested parties, either buyer or seller, may refuse to accept it, because such inspectors are employed by one of the parties to protect his interests. Shippers usually accept the inspection, provided there is not too high a per cent of off-grades, while buyers are much less prone to accept shippers' inspection at the mill. The mutual distrust, especially on the part of the buyer, is responsible for the existence of the second group, namely, those who are the independent or consulting inspectors. This group may be employed at different times by either the buyer or the shipper to protect his interests.

As a rule, the survey of the consulting inspector is accepted as final. Disputes sometimes arise necessitating the employment of other inspectors. In theory, the consulting inspector should be acceptable both to buyer and seller, but in actual practice his selection is largely in the hands of the buyer, since the latter may refuse to purchase unless satisfied. However, it is not uncommon for the shipper to have a representative on hand during the entire survey.

The first group of inspectors are on the payrolls of the concerns employing them. The second group, the consulting inspectors, charge a fee for their work, the cost per thousand board feet being dependent on the size of material and the species. For stock such as boards and for small material a daily charge usually is made, since the inspector can handle only a limited amount of material per day. One inspector can survey from 50,000 to 100,000 board feet per day of plank and dimension, from 80,000 to 100,000 board feet of timbers; and from 1000 to 2000 cross-ties, the average including the time lost by delays in unloading being from 1000 to 1500.

## CHAPTER XVII

### TRANSPORTATION

FOREST products are carried to the domestic markets chiefly by the railroads, although there is an extensive coastwise trade on the Atlantic and Pacific seaboard. In addition, lumber is moved by vessels on the Great Lakes and by barges on some inland waters. Short distance transportation by motor truck, or wagon is used in some sections to move the product of small mills to connecting points on trunk-line railroads. Flumes also may be used to bring products from the forest or mill to rail connections with outside markets. Rafting lumber rarely is practiced to-day.

#### RAIL TRANSPORTATION

##### Tonnage.

A large amount of tonnage is furnished to the railroads of the United States by the lumber industry, exceeding that provided by all other industries, except mining. A report of the Interstate Commerce Commission dealing with railroad transportation during 1914 states that railroads of Classes 1 and 2<sup>1</sup> hauled during that year 84,676,144 tons of lumber and that the total tonnage of forest products, including lumber, was 200,000,000. This volume was 10.23 per cent of the total tonnage handled by railroads during that year, and exceeded by 2.38 per cent the combined tonnage of animal products, by 3.6 per cent the tonnage of merchandise and by 0.04 per cent the combined tonnage of all products of agriculture. Bituminous coal was the only commodity that exceeded forest products.

The freight receipts per ton mile were 6.98 mills, yielding a revenue of more than \$103,000,000, which was nearly double that received from grain and about 60 per cent of the income from moving bituminous coal.

The average length of haul for lumber traffic was 175 miles, as compared to 226 for grain, 139 for hay, 201 for cotton, 212 for live stock, 334 for dressed meats and 133 for bituminous coal.

In general, lumber is regarded as a desirable form of freight. It is not perishable, requires no special care during transit, and does not

<sup>1</sup> Includes all roads the annual operating revenue of which exceeds \$100,000.

have to be moved at certain seasons of the year as do cotton, hay, grain and, to some extent, coal.

Although the lumber industry furnishes more than 2,000,000 car loads of freight annually to the railroads, the latter do not supply the industry with special equipment for shipping its products, such as are provided for carrying coal, coke, grain, cattle, furniture, automobiles, and various other commodities.

### **Car Stakes.**

Lumber is shipped in all kinds of cars, and when flats or gondolas are provided the shipper must make the load secure with wooden uprights and cross braces of dimensions prescribed by the Master Car Builders rules and of sufficient strength to retain the lumber on the car, without danger of injury to persons or property. The cost of thus equipping cars for hauling lumber must be borne by the shipper since he receives no compensation from the consignee for the material. In addition to furnishing stakes, the shipper was obliged to pay freight on them, their weight ranging from 500 to 1000 pounds per car.

A formal complaint was filed with the Interstate Commerce Commission on July 12, 1905, amended in 1906 and again in 1907, by the National Wholesale Lumber Dealers' Association against railroads in the Southern Classification territory asking that the roads mentioned be compelled to furnish the required stakes and standards at their own expense. The matter was considered at various hearings before the Commission which, on June 23, 1908, rendered an adverse decision on the basis that freight rates on lumber had always been made on the presumption that the shipper so loaded the car that the contents could be transported, safely, to destination. Lumber shippers, therefore, had no cause for complaint.

The lumber shippers also had contended that, in any case, they were entitled to an allowance of 500 pounds weight for stakes, in accordance with a regulation issued by the railroads on January 2, 1905, which stated that "an allowance of 500 pounds weight will be made for racks on flat or gondola cars, if loaded with freight requiring their use." On February 1 of the same year the railroads had issued a new regulation to the effect that the allowance mentioned did not cover "stakes used on flat or gondola cars loaded with lumber." During the progress of the hearings the principal railways operating in all sections of the country agreed to this allowance for lumber shipments in open cars and this allowance was upheld by the Commission. In 1911 roads in the Western Classification territory attempted to abolish this allowance, which, however, was not permitted. Other roads at various times have also

made efforts to overthrow this practice. All roads in the United States now make this allowance for lumber, and some also apply it to logs and other forest products. Some roads do not make such an allowance unless the weight of the shipment exceeds the minimum car capacity. Roads in the Pacific Northwest also provide for an allowance of 250 pounds on double loads and 500 pounds on triple loads when chains are used to bind loads of long lumber, poles and timber, provided that the minimum carload weight specified will be charged for each car.

### Car Capacity.

The regulations of common carrier railroads specify a minimum loading weight for cars of a given length for which freight will be charged on car-load lots, that is, the minimum charge will be on the basis of this weight, if a car-load rate is paid, unless the actual weight exceeds the minima in which case charges will be based on actual weight. The minima in effect in all sections except the Pacific Northwest, are 34,000 pounds for cars 36 feet and over in length, inside measurement, and 30,000 pounds for cars under 36 feet. Since 1907, the basis for determining minimum weights for lumber shipments from the Northwest and the Inland Empire has been an assumed cubical car capacity, 20 pounds weight per cubic foot, being the converting standard. Until September 24, 1917, railroads recognized 1651 cubic feet capacity as the minimum but on that date it was raised to 2400 cubic feet capacity as the minimum, or 48,000 pounds. The lumber industry in these regions protested against this discrimination since it often was impracticable to load cars to the minimum capacity determined on the cubical basis. Several hearings were held before the Interstate Commerce Commission and in April 1922, the Commission handed down a decision finding unreasonable the cubical capacity carload minima on pine, fir, hemlock, and spruce lumber and articles taking the same group rates, in closed cars, from north Pacific Coast and Inland Empire points to eastern destinations. The carriers were notified to establish on or before June 12, 1922, the following minima: For cars 36 feet and under, 38,000 pounds; cars over 36 feet and not over 42 feet 44,000 pounds; and cars over 42 feet, 54,000 pounds.<sup>1</sup>

The minimum weight for southern products, which on account of length require two or more cars for transportation, is 24,000 pounds per car, and on the West Coast 33,000 pounds per car. In addition, the freight rate on products from Pacific Coast points, requiring two or more cars, is 13½ cents higher than single car shipments. Southern shipments of like character do not carry an increased rate.

<sup>1</sup>See Docket No. 10,128, Interstate Commerce Commission,

The average lumber capacity per car has risen gradually during recent years owing to the scrapping of small-capacity cars by the railroads and to an effort on the part of the lumber industry to load cars to "visible capacity."

In 1894 the average car load of lumber was approximately 10,000 board feet, while the average in 1921 for southern yellow pine was in excess of 21,000 board feet. Loads exceeding 63,000 board feet have been reported for flat cars, but such capacities are rarely attained. The general rule regarding lumber shipments is that cars may be loaded 10 per cent in excess of stated capacity stenciled on the car. The height above rail on open cars must not exceed 13 feet. It is rarely the case that a 10 per cent excess can be loaded on any car, except possibly when some of the heavier hardwoods comprise the shipment. In case of loads exceeding the maximum weight, the carrier may unload the excess at the shipper's expense.

### **Car Weighing Service.**

The determination of the weights of lumber shipments, in car-load lots, is made by weighing the load on railroad scales, either at the mill or at some terminal point. On local or other shipments, where railroad scales do not exist between the points of origin and destination, the weights are determined on the basis of arbitrary estimated weights per thousand board feet, specified in the tariffs issued by carriers. Large mills are usually equipped with railroad scales, or the railroad provides weighing facilities so that actual weights may be determined at the time the shipment is accepted by the railroad.

The weighing on mill scales may be in charge of a joint employee of the shipper and the Railway Weighing Association, which has jurisdiction over the territory in which the shipment originates. When railroad-owned scales are used the local station agent has charge of the weighing, the shipper usually having a representative present at the time the weighing is done.

The shipper often makes a check on lumber weights by comparing the estimated association weights of the car contents with weights as shown by the scales. A noticeable discrepancy between the two is subject to investigation before delivery of the consignment to the railroad and also furnishes a means of determining the accuracy with which the lumber shipment has been checked out by the shipping department. A shortage or excess in the amount of lumber placed in the car frequently can be detected in this manner.

An advantage in weighing lumber at the point of origin is that open-car shipments when rained or snowed upon accumulate an appreciable

weight of water on which freight must be paid and for which the consignor cannot collect from the consignee. The Southern Pacific Railroad at one time made an allowance of 2000 pounds weight per car to consignors where shipments were rained upon before the carload was weighed. This allowance was subsequently reduced to 500 pounds per car and later withdrawn. So far as known no railroad at present makes such a concession. The effect of snow upon the weight of a car was investigated in 1915 by the Western Pine Manufacturers' Association. It was found that 6 inches of snow on the top of a 33-foot box car added 1305 pounds to the weight of the shipment, and on a 40-foot car 2675 pounds; 1 inch of snow on a 33-foot gondola car added 240 pounds to the weight; and 6 inches, 1380 pounds. The disadvantage of this added weight to the lumber shipper is that lumber often is sold at a delivered price based on estimated weights which, of course, do not take into consideration this superfluous weight of water. Therefore, the shipper is reimbursed only for the estimated weight and must pay for the added weight himself.

### Freight Rates.

The payment for the transportation of lumber by rail is on the basis of weight, rates being quoted in units of 100 pounds. The actual rate, per 100 pounds, paid by the lumber produced from different species in a given region often is not the same, an effort being made to equalize the returns per 1000 board feet to the carrier by charging a higher rate on the lighter woods than is charged on those which are appreciably heavier. Shipments requiring special facilities also may be charged a higher rate. Thus western red cedar lumber from the Pacific Northwest is charged a higher rate than Douglas fir lumber; and long timbers, whose length requires two or more cars for single-length sticks, take a higher rate than products which require one car only.

Through rates are "blanketed," that is all lumber originating in a competing unit or sometimes along a given line of road takes the same through rate to distant markets, even though the most widely separated mills in the blanket may be several hundred miles apart. Each mill, therefore, in the blanket area is able to compete, on equal transportation terms, with every other mill, without regard to location. Thus southern pine mills in Arkansas and Louisiana, below Little Rock, Arkansas, have the same rate into northern markets; mills in the Seattle district in Washington have the same rate to the "Minnesota Transfer,"<sup>1</sup> and mills in the Inland Empire the same rate to the Minnesota Transfer,

<sup>1</sup> A terminal point between St. Paul, and Minneapolis, Minnesota.

there being a differential in favor of the latter mills because of the shorter distance and because of the elimination of the haul across the Cascade Mountains. Local rates are not blanketed and are relatively higher than the through rates, since the latter are competitive and in order to secure lumber tonnage the railroads must place the rates low enough to enable shippers to compete with lumber from other producing regions.

One of the largest "blanket rate" areas in the South is west of the Mississippi river comprising an area about 400 miles long and 300 miles wide, the boundaries of which are almost identical with the territory in which shipments of longleaf and shortleaf pine originate.

In support of the "blanket" idea in rate making, the Interstate Commerce Commission in 1915 said, "There is perhaps greater warrant for the group or blanket system of rate making when applied to an area containing natural resources than in any other case. There may be a valid question whether unqualified approval should be accorded the establishment of a common rate from points differing materially on distance to a common market when the producing interests could, without prejudice to consumers, be located at nearer points involving a lesser aggregate cost of transportation. Unless warranted by clear advantage to consumers, a minimization of waste involving unnecessary transportation cost should be sought. When, however, materials are found only in delimited areas and consumed throughout widely extended markets, in which case there is no possibility of shifting the sources of supply, there is much to be said for blanketing the rates from such a common source to the gateways where these materials radiate to consuming markets."

Blanket rates from the producing regions are a benefit to the consumer because they offer buyers a wide range of choice of product; and they create competition between producers over a wide territory and in this manner prevent the establishment of exorbitant prices for the products.

Inconsistencies arise, however, in the application of blanket rates, due to the arbitrary lines dividing the territory of two or more rate groups. Mills on the outer edge of one blanket area tributary to a given market may have a rate to that market which is several cents lower than another mill located in an adjoining area a few miles away. Both mills, theoretically, should have the same rate, but being in different zones they must pay the rate from that zone. The Interstate Commerce Commission in passing on such cases has ruled that since the blanket-group idea is a good one, individual exceptions can not be made in its application and, therefore, an individual may have to suffer in order that the greatest good may be shared by the greatest number.



### Classification.

The classification of lumber and various forest products has occupied the attention of the carriers and the lumber industry during recent years, owing to the long-standing confusion which has existed with reference to it. Each railroad has made its own commodity classification and although an effort has been made in some rate-making districts to secure uniformity in this matter, there is still a marked difference between the classifications used by different roads. Many complaints with reference to classification were filed before the Interstate Commerce Commission, as a result of which the Commission in 1913 suggested that a uniform, nation-wide classification list for lumber and forest products be drawn up by the classification committees of the common carriers.

On July 9, 1915, the Interstate Commerce Commission began an inquiry into the rates, practices, rules, and regulations of common carriers governing the transportation of lumber and forest products. Data compiled from a questionnaire sent out to the lumber industry by the Interstate Commerce Commission in July, 1915, disclosed the fact that there was not any uniform relationship between commodity rates on wood articles and lumber products and lumber rates; and that, in many instances, different rates were made by carriers for hardwoods and softwoods, and that higher rates than those for hardwoods and softwoods usually were assessed for so-called "woods of value." The consensus of opinion was that a uniform list for lumber products was desirable and that it should apply throughout the entire country, that all of the ordinary and customary products of the sawmill and planing mill of the lumber manufacturing plant should be included in the lumber classification and move at the same rate without reference to grades, or values, and that mixed car lots should move at the same rate as straight car lots.

A committee representing rail carriers in the Central Freight Association territory made public a proposed plan for lumber classification which placed planed goods or mill work in a higher class than rough lumber. In this classification they proposed to apply the basis rate on lumber to agricultural implement material which was rough sawed or which had been sawed or split from a bolt or log; and to tanbark, shingle bolts, chair stock, cooperage stock, handle material, laths, logs, rough lumber, piling, posts, poles, sawdust, shavings, and shingles. When the above products were manufactured from "woods of value," the rate was to be 15 per cent higher.

The second class which took a rate 5 per cent higher than the base, covered baseboards, moldings, wainscoting, flooring, lumber surfaced

on one or two sides and  $\frac{1}{8}$ -inch or more in thickness, cross arms, and grain doors.

The third class taking a rate 10 per cent above the base included agricultural and vehicle implement material, rough sawed or bent to shape.

The fourth class taking a rate of 20 per cent above the base for common woods and 40 per cent above the base for "woods of value," included agricultural and vehicle implement material bored, tenoned, or mortised but not further finished than rough shapes; astragals; chair stock bent, bored, turned to shape or sawed to shape but not further finished; and lumber over  $\frac{1}{16}$  inch and less than  $\frac{1}{8}$  inch.

The rates applicable to mixed car-load shipments were to be those of the highest rated commodity in the car.

The Interstate Commerce Commission then undertook a study of the classification of forest products from the rate-making viewpoint in order to determine the soundness of the carriers' plan to impose a higher classification on planed products than on rough lumber.

The carriers' plan was opposed by the lumber industry chiefly on the following grounds.

1. It would cause a disturbance of the existing commodity grouping of lumber and planing-mill products and would revolutionize the conditions under which the lumber industry had developed.

2. The small dealer who was accustomed to buy mixed car lots would probably be forced out of business. He could not afford to pay freight on the entire shipment on the basis of the rate applicable to the highest class product in the car, since nearly 75 per cent of all mill shipments contain at least some surfaced lumber.

3. Dressing lumber at the sawmill plant creates new tonnage for railroads by the utilization of what would otherwise be waste. This practice would be unprofitable if a higher rate were charged on the dressed stock.

4. It is impracticable to grade the ratings on lumber in accordance with the process of manufacture since the prices received on large rough timbers might be higher than on low-grade dressed boards. Further high-grade rough stock brings a higher price than dressed low grades. The practice of surfacing low-grade stock would have to be discontinued because it could not be marketed profitably on a freight rate that was higher for dressed than for rough stock. Planing mill operations at sawmills therefore would be greatly reduced, to the detriment both of the workmen engaged in such work and to the consumer who had need for low-grade material.

Various hearings were held before the Interstate Commerce Commission with reference to the classification proposed, during which the

idea of placing a higher rate on planed products of the sawmill than on rough lumber, was abandoned by the carriers. Opposition to a uniform nation-wide classification also developed among lumber manufacturers, those from the West Coast failing to support this feature on the grounds that the conditions of production and transportation throughout the entire country are too dissimilar to apply one rule to all. This region also expressed the opinion that the existing classification was reasonably satisfactory to the industry at large and that minor changes only were necessary.

During the latter part of 1916 an examiner, Eseh, of the Interstate Commerce Commission suggested a plan of classification for lumber products, in which the basis of lumber rate making should be weight wherever the product will load to a prescribed minimum, which he suggested might be 50,000 pounds. The latter figure was arrived at tentatively by taking the average weight of some 17,000 car loads of lumber shipped from all producing regions, which approximated the assumed average weight.

His plan proposed to apply the base rate to the 50,000-pound minimum and to lower the rate per 100 pounds for shipments in excess of this amount and to increase it for shipments below the minimum thus rewarding the shipper who loaded to capacity and penalizing those who did not do so. Changes in rates were to be made only on 10,000-pound differences, all shipments between 50,000 and 60,000 pounds taking the same rate and those between 40,000 and 50,000 pounds taking a higher rate.

This plan did not appeal to the lumber industry because of the great variation in the weight of different kinds of lumber for with the lightest species the shipper would undoubtedly be penalized, even though he loaded to visible capacity.<sup>1</sup>

Various lumber trade associations filed briefs with the commission with reference to the Eseh plan, most of them in opposition to its adoption. Favorable action on the matter has not been taken and the present lumber classification is substantially the same as that which has been in use for many years.

### **Milling-in-transit.**

The privilege of stopping shipments of logs, rough lumber and various other forest products at some central point for seasoning, re-manufacture or other treatment and the later shipment of the finished product to destination on a through freight rate from point of origin of the rough lumber to the destination of the finished product, known as the "milling-

<sup>1</sup> The chief points in the Eseh plan are outlined in the Timberman, Jan., 1917, page 30; Feb., 1917, page 48*b*; Dec., 1917, p. 40.

in-transit" privilege, has been a common one for many years. It has been of special benefit to small lumber manufacturers the volume of whose output does not warrant the installation of re-manufacturing facilities at the sawmill plant, and who would be forced otherwise to market their entire product in the rough. Wholesale dealers have found the milling-in-transit privilege of great advantage in that it has enabled them to concentrate the output of small mills at central points, re-manufacture and regrade it and ship in straight or mixed-car lots to buyers.

Independent planing mills, doing custom work chiefly, have been established at many central points, near the lumber producing regions and form an important link in the preparation of lumber for market. Various abuses grew up in connection with this privilege, among which were the substitution of one product for another. This led to a ruling of the Interstate Commerce Commission in July, 1909, that an interchange of tonnage was permissible only when the identical commodity or its exact equivalent was forwarded to final destination. Thus it was not permissible to substitute shingles for lumber, or oak for maple, or vice versa. In 1913 another ruling provided that a substitution of tonnage of like commodities was allowable such as hardwoods for hardwoods, but that unlike commodities could not be substituted, such as hardwoods for softwoods. Permission to conduct the business on a tonnage, instead of a car for car basis, also was granted.

The assessment of freight charges on such shipments is not uniform. Many roads charge local rates inbound to the transit point, and apply a through rate from the original point of shipment to final destination, plus a charge for stop-over service. A refund of inbound charges is made, sometimes on the basis of the weight of rough lumber to the transit point, minus a transit charge; at other times on the basis of the weight of the commodity reshipped minus a transit charge, or on that basis after loss of weight has been taken into account. Most tariffs specify that the through rate applied shall be that in effect at the date of shipment from the point of origin. In some cases a stop-over charge is made; in others it is not.

Various other combinations, which are in effect, apply to tariff rates on milling-in-transit shipments, but the general practice followed is that stated above.<sup>1</sup>

### **Transit Shipments.**

The forwarding of unsold car-load lots of lumber to some central point of reconsignment with the expectation of sale before arrival is a

<sup>1</sup>A complete discussion of the various provisions referring to milling-in-transit rates and provisions may be found in Digest of Answers to Interrogatories propounded by the Interstate Commerce Commission in Docket 8131, Washington, 1916, pages 45 to 50.

common practice in the lumber industry. Although in general it is regarded as an evil by manufacturer-wholesale dealers, many of them forward transit consignments during dull periods when they find it necessary to move stock. It is also followed in some cases when it is desired to move a few car loads of special stock. Wholesale dealers and small mill operators also place lumber products on the market in this manner.

Wholesalers, commission men or possible buyers are notified of the character and amount of consignment and the point to which it has been billed in the hope that it may be sold by the time it reaches the original billing point. In case no sale has been effected previous to reaching the reconsignment point the shipment is subject to the demurrage rules in force. When a sale is effected, the shipment is rebilled to destination, for which a fee is charged by the carrier. Transit cars often are a disturbing element during depressed market conditions, since the shipment may be offered at a price below the general market in order to avoid the accumulation of demurrage charges. On the other hand they are regarded as a benefit by many in that retail buyers can secure shipments on short notice and, therefore, they do not have to carry as large a stock of lumber as would be necessary if all purchases were made direct from the mills. Shipments of shingles from the West Coast are largely made on the transit basis, the custom originating in the Northwest about 1893 in order that producers might enter the markets of the Middle West and East in competition with producers in those regions who had the advantage of a source of supply close to market.

At first transit shipments were made to various points west of the Mississippi river, but in 1900 the roads attempted to break up the practice of shipments of lumber and shingles to points west of the Missouri river, unless the name and address of the party to whom notice was to be sent was given.

Railroads, at one time, allowed storage in cars at the transfer points but this practice kept so many cars out of active service that it became burdensome and a warehouse storage privilege was granted to shippers. In 1904 the western trunk lines issued a notice prohibiting the storage of shingles in cars, warehouses, or on other property owned by them, but arrangements were made for such storage at the Minnesota Transfer, by the Minnesota Transfer Railway, for which a monthly charge was made. An average of approximately 15 per cent of current shipments often are held in storage.

This transfer still remains the chief central shingle distributing point for the Middle West and eastern trade. Efforts have been made by some manufacturers to break up this practice on the grounds that the reasons for its establishment, namely, the development of eastern

markets and the provision of eastbound tonnage for western roads had disappeared, and that the practice now does much harm because it induces speculation in the wholesale shingle markets.

The practice has been strongly defended by small shingle producers, who maintain that a steady flow of shipments from their mills is essential to successful operation since they cannot profitably store shingles at the point of production because kiln-dried shingles in storage absorb enough moisture to rob them of their "underweights."<sup>1</sup> Brokers also defend the practice because it enables them to make quick delivery in eastern territory from consignments which are on their way to, or have arrived at the Minnesota Transfer.

### TRACTION ENGINE TRANSPORTATION

Traction engines were extensively used, prior to the introduction of motor trucks, for transporting the product of portable mills to the railroad. They were much more effective on long hauls than animal-power but have proved less efficient than motor trucks under average operating conditions, because of their slower speeds. On long hauls and with heavy loads they do not average more than 20 miles per day and usually require a crew of at least two men. The limited fuel and water supply which can be carried with the engine also necessitates providing special fuel and water facilities along the route.

### MOTOR TRUCK TRANSPORTATION

The use of motor trucks for the transport of lumber from small mills located at some distance from railroads has become increasingly important during the past few years. They have now largely supplanted wagons and animals because of their greater efficiency and reduced operating cost.

The equipment for this purpose has not been standardized, trucks of different rated capacities being used by different operators. When trailers are used their rated capacity is from 2½ to 5 tons.

The average loads hauled range from 2000 to 5000 board feet of green lumber depending on the size of the truck and the character of the roadbed. The daily truck mileage is from 60 to 100 miles. The cost of motor truck haulage for distances of 6 miles or more is usually from one-half to one-third of the cost of animal haul under the same conditions.

<sup>1</sup> Underweights is a term used to denote the difference between freight charges to the buyer based on standard weights on which freight to destination is computed, and freight charges paid by shipper on actual railroad weights. This difference often constitutes the chief profit made by shingle manufacturers.

This form of transport has great future promise for use in all parts of the country in hauling portable mill products from scattered stands of timber.

## WATER TRANSPORTATION

The early method of transporting forest products to market was by water, since railroad transport was not developed and the chief domestic markets were located in centers accessible to tide-water or to the various lakes and rivers of the country. The water-borne traffic was moved in vessels and barges and also by raft.

### Vessels.

The traffic from Atlantic and Gulf ports was the first trade developed, because an abundant supply of raw material was available to shipping centers from Maine southward. The tonnage along the Atlantic seaboard has been carried chiefly in sailing vessels with capacities ranging from a few hundred thousand to one million board feet. The products were delivered at Baltimore, Washington, Philadelphia, New York, and Boston, and often delivery of a cargo was made at several docks, since facilities were not available for handling a large volume at one place. This intercoastal sailing vessel trade is still a factor in lumber transportation, but is of less importance than formerly because of the decreased amount of lumber available to tide-water. Steamer-borne cargoes from Gulf ports have been a feature of the trade in recent years but the volume of lumber so moved has been limited.

The destination of shipments from the Pacific Coast have been confined largely to points along that coast, chiefly California. The cargo trade began in the redwood region at the time of the discovery of gold in California and a large part of the supply of building and construction woods used in that state for many years came from points in northern California. About 40 per cent of the redwood shipments still move from the redwood region by water. The water trade from Washington and Oregon is now chiefly with California, 12.6 per cent of the total shipments from the two states, both rail and water, being reported as consigned to California in 1920, and only 0.87 per cent to the Atlantic seaboard. Water shipments both domestic and foreign were 20 per cent of the total.

The early lumber trade with the Atlantic seaboard was around Cape Horn in sailing vessels, but the opening of the Panama Canal has led to an increase in steamer shipments, often in parcel lots. The high rail freight rates to Atlantic Coast points have aroused added interest in the

use of the Panama Canal route but due to the lack of vessels suitable as lumber carriers, and to the inadequacy of storage facilities for large cargo shipments the volume of water-borne business has not increased to the extent shippers anticipated.

During the height of the lumber industry in the Lake States large quantities of lumber were moved to the wholesale distributing centers by steam-vessels. This trade has now shrunk to small dimensions. Occasional shipments still reach the markets from milling points on the Great Lakes and from the Georgian Bay region of Ontario, Canada. Several hundred million feet formerly reached Chicago by water but in 1920 the receipts were under 35 million board feet, a decline of 60 per cent since 1917.

### **Barges.**

The use of barges for transporting lumber has been practiced on the Mississippi river and to some extent along the Atlantic and Gulf Coasts.

Barges having a capacity of from 600,000 to 700,000 board feet have been used to bring lumber from the lower Mississippi to St. Louis, Cincinnati, and other accessible points. A permanent service of this character has not been established by any transportation company, the use of barges being greatest during periods of acute car shortage on the railroads. The barging of lumber from the mills along the upper Mississippi to points as far south as St. Louis, was practiced during the early "nineties," replacing the rafting methods previously in use. Attempts have been made at various times to develop a barge line from southern coastal points to northern markets. Some shipments of this character were reported in 1896 and again in 1919, but so far as known this form of transport is rarely used. Occasional shipments of lumber from Gulf ports by barge to Mexican ports have been reported, but an extensive development has not taken place.

### **Rafts.**

The early sawmills of the country other than those on tidewater, were established on the upper waters of creeks or rivers which not only furnished water power for the mills but also an outlet to the outside market. The local distribution of lumber from such mills was limited to the territory which could be covered profitably by a wagon-haul service. Canals and railroads were not available and the outside markets could be reached only by rafting the lumber down the streams to cities or to tidewater where the product was loaded on vessels for coastwise or foreign shipment.

Rafting on the streams in New York state began about the middle of



the 18th century and continued until about 1890,<sup>1</sup> and began about 1800 on the streams in Pennsylvania and was abandoned about 1907. Fox describes the early rafts run on the larger streams as being made up of a number of "platforms," the completed raft being about 48 feet wide and 160 feet long and containing approximately 180,000 board feet of lumber.

Each "platform" was composed of from twenty-five to thirty courses of 16-foot lumber, the boards in alternate courses being laid at right angles to those just below. The platforms were bound together along all four sides by 2-inch round wooden pins passed through auger holes near the ends of the boards. The larger rafts were made three platforms wide and ten platforms long, all being fastened together by cables. They were controlled by means of long sweeps or oars, three of which were placed both on the forward and the rear ends.

A shanty was built on one of the forward platforms and housed the crew which comprised twelve to eighteen raftsmen. Under favorable conditions from 40 to 50 miles per day could be traversed during daylight hours. Deck loads of shingles and laths sometimes were carried and sold at points along the stream where there was a demand for such products.

Rafting of sawed products from interior points to tidewater was practiced for many years in the Carolinas and in Georgia. The lumber was cut in dimension sizes by small mills and, in a green condition, made into rafts along the bank of some stream and later launched from the slanting ways on which it was constructed. The raft units usually were 12 feet wide, 34 feet long and about 24 inches in depth, each unit containing from 4000 to 10,000 board feet and the total board feet in the raft running from 60,000 to 125,000. Each unit was built on a framework of timbers on which the sawed material was piled at right angles, in a compact form. Binders were then placed across the top of the load and fastened to the framework by hickory or oak pegs, driven through auger holes, and the framework later wedged.

The completed raft known as a "batch" consisted of about twenty units fastened together end to end by wooden strips, known as "ties" which were 2 feet long, and had a hole bored in each end into which wooden pegs were inserted and driven into auger holes in the framework of the rear end of one and the forward end of the following unit. This method of coupling allowed some play in the raft units, and also permitted uncoupling the units when the raft had to be floated under a bridge or through a narrow channel.

Such rafts were floated down the stream with the current, until tide water was reached, when they were tied up at flood tide and floated

<sup>1</sup>See A History of the Lumber Industry in the State of New York, by William F. Fox, U. S. Dept. of Agriculture, Bul. 34, Washington, 1902.

on the ebb tide. A crew for handling such a raft consisted of from one to three men according to the size of the "batch" and the difficulties encountered in floating. These men lived in a small lean-to constructed on the forward part of the raft. The raft contents were delivered either at sawmills on tide water for re-manufacture or were loaded directly on schooners for shipment to coast-wise points.

Lumber rafting on the Mississippi river was a common method of moving lumber to markets down stream, as late as the early "nineties." The type of rafts used for this purpose were not built in accordance with any specified plan but most of them conformed to the following general scheme. The lumber as it was saved was sent to a rafting shed and made into cribs. Each crib was built up on a foundation made from seven "grub" planks each 2 by 12 inches by 16 feet, in the ends of which holes were bored and ash or hickory pins 3 feet long inserted. The lumber was stowed on this skeleton frame to a depth of about 26 inches, each crib containing about 12,000 board feet. Grub planks similar to the foundation pieces were placed on top of the lumber directly over the lower planks and the wooden pins of the framework inserted in the holes in the upper grub planks, which were then pressed down tightly, and the pins wedged. The crib was then dumped from its cradle into the water. Sixteen cribs were made into a "string" by connecting them together with short coupling planks. Twelve strings often were made into one raft, the size of the latter sometimes being twelve cribs wide and thirty-two cribs long. Such a raft contained about 2,300,000 board feet of lumber. Cribs of white pine lumber often carried a top load of 6000 laths and 20,000 shingles, but Norway pine lumber would not support such a heavy load. The rafts were sent down-stream under the control of end-wheeled steamers.

It is reported that as high as 100,000,000 board feet of lumber were sent down river, annually, from mills on the St. Croix river, alone.<sup>1</sup> As late as 1899 a raft of lumber containing 7,300,000 board feet of lumber with a deck load of laths and shingles was sent from Stillwater, Minnesota to Clinton and Dubuque, Iowa. This raft was 250 feet wide and 2270 feet long and was the largest single lumber raft sent down the river. Rafting on the Mississippi river has now been abandoned because of the closing of practically all of the large mills which were formerly located along its banks.

Lumber rafting was tried on the Pacific Coast in 1898 during which year a raft was built on the Columbia river near Portland, Oregon, and towed to San Francisco, California. This raft was 400 feet long, 50 feet wide and 24 feet high containing approximately 5,000,000 board feet of lumber. It reached its destination, although some lumber was

<sup>1</sup>See *Northwestern Lumberman*, June 10, 1893, page 9.

lost during the inclement weather encountered on the trip. A second raft was reported under construction during the late summer of the above year, but the practice has not become an established one. Later developments in rafting from this region were for log transportation, several log rafts being built, annually, and towed from the lower reaches of the Columbia river to San Diego, California.

A revival of interest in lumber rafting occurred in 1919 when several plans for rafts to transport lumber on the Baltic Sea in Europe were given publicity in lumber trade journals in this country.<sup>1</sup> Designs for ocean-going lumber rafts along similar lines were developed in the Northwest and in British Columbia but none were constructed so far as is known.

<sup>1</sup>See *American Lumberman*, Jan. 4, 1919, page 50; May 31, page 64; Dec. 13, page 65; *West Coast Lumberman*, May 1, 1920, page 220; *Lumber*, April 19, 1920, page 18; and *Timberman*, Sept., 1920, page 48j.

CHAPTER XVIII  
DOMESTIC MARKETS

METHODS OF SALE

**Wholesale.**

During the early days of the industry, wholesale lumber merchandising was largely carried on by dealers who were located at central distributing points which were accessible by water to the large white pine producing centers. The manufacturer did not deal directly with the retailer or large consumer but sold his product "mill run" to some middleman who accumulated stocks at convenient centers where the lumber was assorted and re-manufactured to meet the market requirements. Among the cargo centers developed were those at Albany, New York; Burlington, Vermont; Chicago, Illinois; Cleveland, and Toledo, Ohio; Tonawandas, New York; Norfolk, Virginia; and Baltimore, Maryland. These centers handled the early output of the Northeast, the Lake States, and the southern yellow pine region in Virginia and North Carolina. The importance of these markets as points of accumulation and distribution has now greatly diminished because of the disappearance of the raw materials available to them by water transportation.

The wholesale distributing market was never an important factor in the southern yellow pine trade, other than at Norfolk and Baltimore, because the majority of the mills were inland and the practice of shipping car lots directly from the mill to yard dealers, contractors, and large industrial consumers, became general early in the history of the industry in that region.

The lumber business in the interior southern yellow pine producing states first became of importance in the early "nineties" of the last century and the chief outside markets were in the prairie states west of the Mississippi river and in a few states east of the Mississippi and north of the Ohio river. Previous to 1890, white pine and Norway pine from the Lake States had largely dominated this field, but about this time southern yellow pine, because of its cheapness, began to enter the middle

western territory in large volume and for the last twenty years has been the dominating lumber product in this region.

The central wholesale markets have been replaced largely by wholesale jobbing centers, which developed at Kansas City and St. Louis, Missouri; Louisville, Kentucky; Cincinnati, Ohio; Pittsburgh, Pennsylvania; Chicago, Illinois; Detroit, Michigan; Milwaukee, Wisconsin; and Buffalo and New York city, New York. To-day there are agents who represent manufacturers in every important yellow pine consuming center.

The development of the market for Pacific Coast fir, cedar, and spruce has followed much the same general lines as southern yellow pine, in so far as domestic trade is concerned.

The wholesale dealer has always been a more important factor in the hardwood than in the softwood trade because nearly 80 per cent of hardwood lumber reaches the consuming market in the rough. It is used by the various wood-using industries for the manufacture of products such as furniture, vehicles, interior finish, box-board stock, and a host of other products. The factory buyers often prefer to purchase their lumber on the basis of special grades which will meet their individual requirements. Wholesale dealers, in many cases, have made a study of factory needs and re-grade and re-sort their product so that the buyer gets the class of stock he desires. The manufacturer never has looked with favor on deviation from standard association grades and, therefore, he has not always met the factory requirements as well as the wholesale dealer. The tendency to "juggle" grades has been more prevalent in the hardwood than in the softwood trades and sometimes has proven an unwholesome feature of merchandising.

Modern lumber merchandising may be separated into two main divisions, namely, wholesale and retail. Many manufacturers are actively engaged both in the wholesale and the retail trade and, on the other hand, wholesale and retail dealers often are actively interested in the manufacture of the class of products which they sell.

*Small Operators.*—The small-mill operator seldom is able to place his product on the market directly because the volume produced is so limited that the cost is excessive. Further the quantity produced of a given grade frequently is insufficient to enable prompt car-load shipments. This handicaps him in competing with larger producers.

The direct market open to small producers is limited to local sales where delivery can be made, direct from the mill, on a short haul. The major part of the product is sold either by grades or by "mill run," to outside wholesale dealers who sometimes aid in financing the operation. It also may be sold to some large local operator who markets the output in connection with that of his own plant. Occasionally the small

operator sells his product through commission agents or brokers who charge a stated fee per thousand board feet, or per car.

It is in the small mill sales, especially in hardwoods, that the wholesale dealer finds one of his largest and best fields. This is true because he is able to concentrate the products of various mills and re-distribute them in the form of mixed car loads of a character that best meet factory needs, but which the average mill usually cannot supply.

*Large Operators.*—The product of large lumber manufacturing plants may be marketed by one of several different methods, or by a combination of one or more methods.

Many large operators maintain a sales department which handles the output of a given mill or a group of mills owned by the same interests. The main office of such a sales organization formerly was at some large distributing center but to-day it often is at the plant or in close proximity to it in order that the sales manager may be in constant touch with stock and shipping conditions. This sales organization may have branch agencies in the larger consuming centers, and one or more traveling salesmen operating either on a salary or on a commission basis. In addition, lumber may be sold through commission agents who have no direct relation to the sales organization.

Selling agencies or sales exchanges, as a medium for distributing the product of a group of mills, have become an important factor during the last twenty years. The exchange represents a group of mills often with interlocking ownership which pool their sales.<sup>1</sup> Such an exchange not only enables mills to reduce their expense by maintaining one sales department, but also to handle orders which individual mills could not fill. This is possible not only because of the greater volume of product available, but primarily because orders can be so distributed among member mills that stocks at individual plants can be kept more nearly "balanced." Selling agencies also may purchase lumber from manufacturers who are not members of the exchange and offer it for sale together with the product of member mills.

The agencies or exchanges are incorporated bodies. The sales methods followed vary with the general purposes for which the exchange was organized. The following general scheme pursued by one exchange in the southern yellow pine region illustrates one of the general co-operative ideas. All stock manufactured by member mills, except car siding

<sup>1</sup>Some exchanges represent a large per cent of the output of a given species in certain regions. An example of such an exchange is the Louisiana Red Cypress Company of New Orleans, Louisiana. This organization markets the product of a majority of Louisiana cypress mills, with the exception of local sales and those made in and around the city of New Orleans. The California Sugar and White Pine Agency is another instance of extensive sales co-operation, this agency marketing a large part of the sugar and white pine output of California.

and ceiling,<sup>1</sup> is handled through the exchange at a fixed charge per thousand board feet. This fee is ample to cover expenses, and if at the end of the year a surplus remains it is returned to member mills in the form of a dividend. The exchange, therefore, is not operated as a profit-making body. The orders are distributed to the various member mills in accordance with their ability to supply the class of stock required. All mills are provided with a copy of every order allocated to each mill, including the price received, in order that each member mill may be fully informed as to the disposition of the orders received by the exchange. All instructions to sales agents are sent to the mills. The latter need not accept the prices quoted if they are regarded as unsatisfactory. Mill shipment reports are made daily by the mills and from these reports monthly statements are made up for the settlement of accounts with buyers. The business subsequent to the sale is handled by the shipper, all invoices being made by and remittances made to him.

The sale of lumber through wholesale dealers is a common practice. The trade definition of a "legitimate" wholesale dealer is one who buys his lumber outright, either at some shipping point or at some point of reconsignment and who secures his profit from a resale of the product. Such firms maintain an office and have an established line of trade. They are in contrast to the commission man, sometimes called a "scalper," who markets lumber for producers on a commission basis. The latter class of distributors is not regarded with favor by manufacturers because they have no vested interest in the lumber they sell, and hence volume of sales rather than price often is the dominating factor in their business. In spite of this the commission man has found a field of operation among small mills and also among large mills when the latter desire to move stock quickly.

The rapid development of sales organizations by the manufacturers during the last twenty years has been due to a desire on the part of producers to retain the profits made by wholesale dealers. This effort has produced some friction between manufacturer and wholesaler because of the attitude sometimes assumed by producers that wholesale dealers are a non-essential factor in the distribution of lumber. While it is true that large producers are able to market the output of their mills successfully, yet there is a legitimate field in the distribution of the product of the army of small mills which, so far, has been handled successfully only by the wholesale branch of the trade. That the legitimate wholesale dealers are an essential factor in the lumber trade, was established in 1918 when an effort was made to eliminate them from

<sup>1</sup> The stock handled by the mills is used largely in the general building trades and the salesmen do not come in contact with railroad buyers. Railroad purchases, therefore, are handled directly by the mills.

participation in government orders during the war. After a spirited, organized fight on the part of the National Bureau of Wholesale Lumber Distributors, an organization formed to protect wholesale interests, the War Industries Board declared them to be an essential factor in the lumber trade.

One of the chief points of contention among the various distributing branches has been the establishment of standards for the classification of the trade, that is, the determination of what may be regarded as the legitimate field of the manufacturer-wholesaler, the wholesale dealer and the retail dealer. The activities along this line date from the establishment of the first retail dealers' "protective" association, the chief purpose of which was to prevent sales by wholesale dealers to those whom retail dealers considered their "legitimate" trade. It frequently happened, especially during periods of dull trade, that manufacturer-wholesalers, wholesale dealers, and commission men sold direct to consumers, in the same town or territory in which a retail dealer was located who was one of their customers. This led to the formation of agreements between the distributors and the retailers which were designed to regulate this trade, but which ultimately involved various associations in anti-trust proceedings instituted both by the Federal Government, and by certain states.<sup>1</sup> The trade channels in recent years have become well defined and there is now little or no conflict in this respect, although there are occasional instances of a disregard of trade practices on the part of some wholesale dealers.

In general, consumers such as wood-using factories, railroads, and construction companies which buy lumber in large quantities are regarded as "legitimate" customers of the wholesale dealer, while sales to consumers who buy in limited quantities for their own use and not for re-manufacture or sale are considered to be exclusively within the field of the retail dealers.

### **Retail.**

Retail yards, mail-order houses, farmers' stock companies, and department stores are the retail agencies by which lumber is distributed. The last two are of minor importance only, in so far as the volume of product handled is concerned. Retail yards distribute 90 per cent or more of the product, mail-order houses being second.

The general principles on which the retail lumber trade is conducted do not differ, in any essential respects from those of other forms of retail business.

Lumber yards in smaller cities carry, in addition to lumber products,

<sup>1</sup> See pages 318 and 324.



a general line of building supplies sometimes including hardware, paints, and patent roofing. In addition they often handle side lines, such as fence wire, gates, posts, and other commodities of a similar nature. In the larger cities the retail yard trade is confined chiefly to lumber, laths, and shingles.

*Retail Yards.*—These may be divided into two classes, the individual or single yard and the “line yards.”

The single-yard type is the most common form of retail distributing agency east of the Mississippi river, and in small towns the business usually is owned and operated by an individual who may control one or more yards in the immediate vicinity. In large cities this type of yard often is operated by a partnership, stock company, or corporation.

The line-yard type of organization operates a group or chain of yards at different points throughout a region, all under the control and direction of a corporation which maintains a buying and supervising office at some large lumber distributing center. The number of yards in such a group varies from a few in number to more than one hundred. This method of lumber distribution has been developed chiefly in the smaller towns, especially in the agricultural regions, west of the Mississippi river.<sup>1</sup>

Such yards are in charge of a salaried manager who looks after the local business of the company, although he has little or no dictation as to the policy of the yard which is under his direction, since purchases are made by the controlling company and prices and terms are issued by it and, in so far as possible, fiscal matters are handled through the central office. Many of the line-yard companies are subsidiaries of some large lumber manufacturing concern, which may furnish a portion of the product sold, although this is not necessarily so, since the purchasing department secures its stock as cheaply as possible and it may be practicable to purchase supplies from other firms for a lower price than the parent organization can sell the same class of stock which has been manufactured in its own mills.

From the standpoint of local development, line-yards often are less desirable than individually owned yards because the latter are operated under the personal direction of the owner who, being a taxpayer and a resident of the town, is interested in the various local problems. On the other hand, the line-yard is under the direction of a paid manager, often a non-resident, and the chief interest of the company is in making a profit from the business. If conditions arise which render the yard unprofitable or reduce profits to a low point, the business usually is closed out.

<sup>1</sup>See *Line Yards (The Chain Store in the Lumber Trade)*, by John M. Gries, *American Lumberman*, March 15, 22, and 29, 1919.

*Mail-order Houses.*<sup>1</sup>—The mail-order or catalogue house distribution of lumber dates from 1906 when a firm in Davenport, Iowa, began to sell mill work and lumber directly to the consumer. Since that time a number of other firms have engaged in merchandising lumber by mail. Although the sales throughout the country aggregate only a very small per cent of the total retail trade in lumber, the companies engaged in selling lumber by mail have met with much opposition from the retail trade associations.

A later development of the mail-order idea was the ready-cut house bill developed by several concerns, especially in the Lake States. These firms have advertised and sold many small houses, the lumber for which was cut to size and shape before shipment, and theoretically only the services of a mason were required to build the foundations and chimneys and those of a carpenter to erect the framework and put the siding and interior trim in place. Union workmen, in some cases, have refused to erect the houses after delivery but many have been put up in rural districts and have proved satisfactory.

Mail-order houses have found it difficult to secure lumber from manufacturers because of retail yard opposition, and manufacturing plants have been acquired in some cases. Distribution yards at transportation centers, in which a stock of lumber is carried, also have been established by some mail-order firms. Business is solicited both by mail and through catalogues.

An advantage possessed by the mail-order house, over the local retail dealer, has been that transactions were for cash, while the retailer's accounts often run from thirty days to one year. The purchaser is at a disadvantage in that he has paid for his lumber before seeing it, while by patronizing a retail yard he can select the stock he desires; moreover, many sales by mail-order houses are in less than car-load lots on which a higher freight rate must be paid than on full cars, hence the delivered cost to the consumer may be so high that there is little or no benefit gained by him in purchasing from them. It is doubtful if the mail-order business will assume large proportions in the future, since the retail dealers now offer better service than formerly, but it is certain that a limited amount of lumber will always reach the consumer through this channel.

*Formers' Stock Companies.*—Stock companies organized by farmers for the handling of grain and the sale of lumber are of comparatively recent date, yet they offer keen competition to retail yards in some of the prairie states, especially in Iowa and Nebraska. There are two types of framers' stock companies. One is strictly

<sup>1</sup> See the Mail Order Lumber Business, by B. C. Mueller, *American Lumberman*, Dec. 2, 16, and 30, 1916, and Jan. 13 and 27, 1917.

co-operative in character, while the other type is organized and operated chiefly for profit.

The farmer companies have met with opposition on the part of the retail yard dealers who have refused, in many cases, to deal with manufacturers who sell to such distributors. As a rule, however, the farmers' yards have been able to secure an adequate stock of lumber to meet their needs.

*Department Stores.*—The idea of retailing short-length lumber in a department store originated in this country in 1914, due largely to the fact that it was very difficult for the householder, who desired a limited quantity of lumber, to secure it from the retail yard. The first store to introduce a line of short lumber was one in Portland, Oregon. At the present time numerous stores in the larger cities from the Atlantic to the Pacific handle short stock suitable for shelves, flower boxes, tabourets, tables, and similar purposes. They frequently offer, cut to size, the necessary lumber for the construction of various household conveniences, also furnishing a blue print showing how the pieces are to be put together. For many years country stores in Australia have carried small stocks of lumber suitable for household uses. A similar development in the United States also should prove profitable to rural merchants.

#### LUMBER ADVERTISING

The lumber industry was tardy in adopting modern advertising methods and it is only within recent years that steps have been taken to handle lumber publicity from a broad national point of view. The general attitude of the manufacturing element has been that "lumber was lumber" and could be sold without advertising. Since the manufacturer dealt chiefly with the wholesale dealer or with the retailer, he did not appreciate the desirability of appealing to the consumer, with whom he did not come in contact.

The chief factor which aroused an interest in widespread advertising on the part of all distributing elements in the industry was the rapid and extensive inroads made in the field of lumber by various wood substitutes, the distributors of which expended large sums of money in placing the merits of their products before the public.

Until 1910 manufacturers were content, in most cases, to confine their advertising campaign to more or less stereotyped business cards in technical and trade journals, calling the attention of wholesale and retail dealers, contractors, and architects to the goods they had for sale.

A great impetus was given to modern advertising methods by the

agitation started in 1912 to hold a Forest Products Exposition for the purpose of bringing before the public, in a visual manner, the wide range of uses to which lumber is adapted. This resulted in the organization of a Forest Products Exposition Company, sponsored by the National Lumber Manufacturers' Association, which perfected plans for and held a most creditable exposition both in Chicago and New York city.

This exposition greatly stimulated group advertising on the part of associations, sales agencies, and various manufacturers who pooled their advertising interests to further the use of given kinds of woods.

Appeals were made chiefly to the consuming public through popular magazines and to wood-users through technical and trade journals. The policy of stimulating the sales of individual operators was subordinated to increasing the use of wood as such, stressing the special qualities of given woods for specific uses. The impression had gained ground among consumers that certain woods, such as eastern white pine, could no longer be secured in large quantities and the efforts of advertisers in that region were devoted partly to convincing the consuming public that large quantities of white pine were still available.

The National Lumber Manufacturers' Association in 1915 established a Trade Extension Department for the primary purpose of increasing the use of wood, leaving to regional organizations the development of a campaign to augment the sale of those species in which they were directly interested.

One of the most aggressive advertising campaigns was that of the Southern Cypress Manufacturers' Association which adopted a new policy with reference to increasing the consumption of that wood, namely, stressing the uses for which cypress was best adapted, and calling attention to those purposes for which cypress was not recommended. The advertising campaign was largely confined to educating the ultimate consumer, the final result being that a large part of the cypress sales was diverted from the factory to the retail trade. This was of great advantage to the producers, since it enabled them to maintain prices when the factory trade slumped. This association has been a leading factor in aggressive advertising for many years and to-day spends a larger sum, pro rata, for advertising purposes than any other manufacturers' association.<sup>1</sup>

As a part of the general advertising campaign, some associations and

<sup>1</sup> As early as 1894, the importance of advertising was recognized by cypress manufacturers. At a monthly meeting of the Southern Cypress Lumber and Shingle Association held on October 25 of that year, the advertising committee, in response to a suggestion that the advertising work of the association be greatly curtailed,

various groups and individuals have adopted distinctive trade marks which are placed upon the ends or faces of boards to designate the quality and source of the product.

Trade-marking has gained great impetus since 1915, at which time the Southern Cypress Manufacturers' Association adopted an official trade-mark. This idea has met with some opposition from wholesale and retail dealers, but on the whole has been well received both by distributors and by consumers. In 1918 one well-known firm which had adopted a trade-mark for its products sent out one thousand questionnaires to retail lumber dealers, architects, contractors, and engineers in order to determine their attitude towards trade-marking lumber. The returns showed that 70 per cent of the retail dealers and 71 per cent of the architects, contractors, and engineers favored the plan.

The majority of the trade marks which are in use by lumber manufacturers are individual, but in some cases, such as in cypress, the trade-mark is the property of the association, all members using the same design, the mill from which the product is shipped being designated by a number used solely by it.

## DISTRIBUTION

### Factors Which Control.

There are two factors which have an important bearing on the distribution of the lumber products in our domestic markets, namely, (a) the physical properties of wood required by the industries and (b) the price at which a satisfactory product can be delivered.

One of the chief requirements in every region is wood for general construction purposes for which all of our softwoods are adapted, although there is a choice among species for special purposes such as for mill work, interior finish, and where maximum resistance to decay is desired. Many industries require woods of special texture, maximum strength, or possessing other special qualities which may be found only in certain softwoods and hardwoods. Species having such qualities are not subject to competition from the general purpose woods and, therefore, may be shipped for long distances at a profit.

The second important factor in determining the distribution of lumber, namely, the delivered price, is influenced by production, marketing, transportation costs, and by the amount of profit which the shipper is willing or is forced to accept on a sale of his goods.

reported that it did not advise retrenchment. "Cypress is a comparatively new wood yet to the lumber world. Four years ago it was unknown in many markets where today it is a staple, and our persistent advertising in the lumber papers, coupled with the friendly articles on cypress which appear from time to time, has, without doubt, been the means and the only means by which we have secured its present recognition."

Production and marketing costs are variables in every region due to the difference in efficiency of operators; to superior manufacturing facilities possessed by some as compared to others; to a wide difference in the quality and cost of raw material; to the range in logging costs due to the location of the stand with reference to the markets; to the character of topography on the logging "chance"; and to climatic conditions, which may affect the cost of delivering the raw material to the manufacturing plant.

The range between the highest and lowest production costs of a given kind of lumber in any region, due to the above factors, is greater than the difference in the freight cost to market of the most accessible timber and that which comes from the most distant regions. It is possible, therefore, for a producer on the West Coast to compete in the eastern markets with the output of the high-cost operators in the South and in the Lake States, and likewise it is possible for southern pine operators to compete with the high-cost operators in the Lake State territory and other regions east of the Rocky Mountains.<sup>1</sup>

The operator with the lowest production costs and the cheapest rates to market does not set the price of lumber in competing territory. On the contrary, the price is determined by the volume of product offered, and by the demand. Under normal conditions, this represents the price at which the operator with average costs can sell and still make a reasonable profit. The high-cost operator, therefore, may make little or no profit, while the low-cost operator may make a large profit on his investment.

When competition is very keen, due to depressed market conditions, the margin of profit for the average-cost operator may shrink to *nil*, yet, in dull periods, producers often continue to place their product on the market at a loss in order to keep their sales organization intact or because their financial condition is such that the manufactured product must be sacrificed in order to secure funds for current expenses.

On the whole, it may be said that transportation cost is one of the prime factors in determining the territory in which the bulk of competing woods, that is, the "common" grades, are marketed, because they represent the quality of lumber which can be produced in every forest region even after the virgin timber has been removed, and, therefore, the competition from local supplies is always present in some measure, which is not true of high-grade products manufactured from

<sup>1</sup> See a discussion of "Marginal Products" in "The Price of Lumber," by Robert B. Goodman, Yale University, School of Forestry, Lumber Industry, Series I, New Haven, Conn., 1920.

choice virgin timber. Low-grade products are the class of stock which the producer finds it most difficult to market because the inferior quality presupposes a relatively low price and a high freight cost increases the delivered price of long-distance shipments to a point where a similar quality of lumber from nearby producing regions can be sold for a lesser price, or else a greater profit realized.

Freight rates for lumber are based on weight and all grades must pay the same rate to a given market. High grades, in which there is the least competition, therefore, can be shipped for greater distances because they can be sold for a price which will yield an adequate return. It is for this reason that the northeastern part of the United States is a common marketing ground for the higher grade products of all regions. Common grades of Douglas fir have only recently begun to enter the eastern markets in large volume because of the high differential in rates between the western territory and the New England spruce region, the North Carolina pine region, and the southern yellow pine region. The greater part of the lower grades from the west do not come east of Chicago. In the territory between the Rocky Mountains and the Mississippi river there is an enormous demand for this class of stock and it can be successfully marketed in competition with hemlock from the Lake States, and southern yellow pine from the Gulf States.

An added reason why eastern markets are not so attractive to far western shippers, when the demand west of the Mississippi river is adequate to absorb a large part of the surplus, is that the shipper to the East Coast usually does not receive payment for his goods for forty-five or sixty days, while on shipments to the prairie regions, settlement of accounts often can be secured in thirty days' time. The middle-western markets, therefore, are the more attractive from a financial point of view, since less working capital is required by the operator to carry on his business.

The bulk of softwood common lumber used north of the Ohio river comes from the southern pineries and from local supplies produced in nearby states.

The diminution in the lumber cut in the producing regions east of the Rocky Mountains is gradually reducing the extent of competition, and the frontier line of Douglas fir common lumber sales is gradually moving eastward towards the Atlantic Coast. The development of water transportation from the Pacific Coast to the Atlantic seaboard, via the Panama Canal, promises to extend the distribution of a large volume of the Pacific Coast product to those eastern states which are readily accessible to tide-water and to the inland territory which can be reached from tide-water on a local freight rate which will permit western shippers to compete with southern products.

### Lumber Production.

The largest volume of sawed lumber produced in this country is southern yellow pine which for twenty years has furnished one-third or more of the total lumber cut.<sup>1</sup> Douglas fir has occupied second place since 1907 and oak is now third in importance, western yellow pine fourth, and hemlock fifth.

In 1919 three softwoods, namely, southern yellow pine, Douglas fir, and western yellow pine, formed 59.9 per cent, and seven softwoods,<sup>2</sup> including the above three, comprised 74.7 per cent of the total lumber cut. Among hardwoods, oak represents the greatest volume, namely, 7.8 per cent of the total production of the country, followed by maple 2.5, gum 2.5, chestnut 1.6, and birch 1.1; a total of 15.5 per cent. The cut of each of the other hardwoods was less than 1 per cent. Thus more than 90 per cent of the total lumber production was represented by the output of seven softwoods and five hardwoods. The production of all species except Douglas fir and western yellow pine has shown declining tendencies during the last decade.

In 1920 seventeen states<sup>3</sup> in the United States manufactured more lumber than they consumed and eleven of these seventeen states produced 67 per cent of the total lumber cut of the country. The largest group is in the extreme western part of the United States, comprising the states of Washington, Oregon, California, Idaho, and Montana, which has a surplus representing 28.4 per cent of our total production; the next largest group includes the states of Alabama, Arkansas, Florida, Louisiana, and Mississippi, the surplus of which is 19 per cent; North Carolina, South Carolina, and Virginia have a surplus of 2.4 per cent; Maine and Vermont have a surplus of 0.9 per cent; West Virginia 0.7 per cent; and Wisconsin 0.37 per cent of our total production.

Although there has been no change in the relative location of the surplus producing centers since 1910, there has been a diminution in the numbers of exporting states. Five states which had a surplus in 1910, namely, Michigan, Minnesota, New Hampshire, Tennessee, and Texas, now have a deficit, and Georgia which in that year produced approximately its requirements, now is forced to buy lumber in large quantities for home needs.

In 1920 there was a decrease in the surplus in all regions except in the Northwest, which showed an increase of 4.4 per cent. The surplus in 1910, expressed in terms of total production of the United States, was

<sup>1</sup> The lumber cut of the United States by states and by species may be found in Tables XLIV and XLV in the Appendix, pages 506 to 509.

<sup>2</sup> These were, in the order of importance, southern yellow pine, Douglas fir, western yellow pine, hemlock, eastern white pine, spruce, and cypress.

<sup>3</sup> The states producing a surplus of sawed products in 1920 are shown in Fig. 1.



as follows: The western group, 16 per cent; southern group, 17.7 per cent; North Carolina pine group, 4.3 per cent; Lake States group, 4.9 per cent;<sup>1</sup> West Virginia, 2.1 per cent; and the New England group,<sup>2</sup> 2.19 per cent.

### Lumber Consumption.

The consumption of sawed lumber in the United States in 1920 was approximately 33.56 billion board feet, or 318 board feet per capita. The maximum consumption, as shown by available statistics, was in 1909, in which year 43.6 billion board feet of sawed products were used which was 482 board feet per capita.<sup>3</sup>

The trend of per capita consumption for the years 1850 to 1920 is shown graphically in Fig. 155. Consumption in the United States has

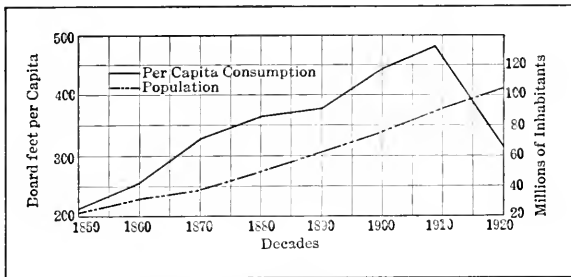

FIG. 155.—The Board Foot per Capita Consumption of Lumber in the United States, by Decades, from 1850 to 1920, inclusive.

now fallen to the level which existed between 1860 and 1870, and if present tendencies continue, in another decade it will have dropped to the level existing between 1850 and 1860. Population increased approximately 1.5 per cent, annually, between 1910 and 1920 while lumber production showed a decline of 16 per cent during this same period.

Softwoods comprised 72 per cent of the total lumber production in this country in 1899, 76 per cent in 1909, and 78 per cent in 1920. Softwood saw timber comprises 79.2 per cent of the total standing timber, hence, the relation between available raw material and production is about equal.<sup>4</sup>

<sup>1</sup> Michigan, Minnesota, and Wisconsin

<sup>2</sup> Includes New Hampshire.

<sup>3</sup> This figure was computed by adding the lumber imports to production, subtracting exports, and dividing the result by the total population.

<sup>4</sup> The stand of saw timber in the United States as given in the Capper Report, "Timber Depletion, Lumber Prices, Lumber Exports and Concentration of Timber Ownership," by the Forest Service of the U. S. Dept. of Agriculture, June 1, 1920, page 32 is as follows: Total saw timber, 2,214,893 million board feet; softwoods, 1,755,218, and hardwoods 459,675 million board feet.

In normal times general construction uses nearly 70 per cent; railroads, exclusive of cross ties, poles and like material, about 10 per cent; and the furniture industry approximately 3 per cent of our lumber requirements.<sup>1</sup>

The chief centers of consumption are the prairie regions of the Middle West, and the agricultural and manufacturing states extending in an unbroken line from the Mississippi river, north of the Ohio river, to the Atlantic seaboard.

In 1910 approximately 67 per cent of the total lumber consumption and 51 per cent of the total production was east of the Mississippi river, exclusive of eastern Louisiana, while in 1919 consumption had risen to 71.5 per cent, and production had fallen to 48.9 per cent.<sup>2</sup> Production east of the Mississippi river in 1910 was 80 per cent of the consumption, while in 1919 it was less than 69 per cent. The source of the eastern lumber supply, therefore, is being shifted rapidly to the Far West, where production continues to increase at a more rapid rate than consumption.

One of the heaviest consuming districts is a group of states touching the Atlantic seaboard and centering around New York state.<sup>3</sup> This territory in 1919 consumed 27.6 per cent of total lumber cut of the country, but produced only 4 per cent of the total cut which is only equal to 15 per cent of the consumption in these states. They must look, therefore, to other regions for 85 per cent of their sawed lumber requirements.

The necessity for importing such a large quantity of sawed products into this comparatively restricted region, comprising only 3.6 per cent of the land area of the Continental United States, including Alaska, makes it one of the chief marketing centers for the various producing regions.

Another important market center is in the territory adjacent to Chicago, Illinois, which is in the midst of a great agricultural and industrial region, while a third center is found in the agricultural region in the prairie states between the Mississippi river and the Rocky Mountains.

Softwoods are the important species in demand in our domestic markets, having comprised 78.9 per cent of the total average production for the years from 1909 to 1920, inclusive. During this period two kinds of softwoods, namely, southern yellow pine and Douglas fir, constituted 51.2 per cent of the average total cut of all species, and during the year 1920, 53.1 per cent. These two woods, therefore, are the

<sup>1</sup> See Capper Report.

<sup>2</sup> 1919 was the last year for which complete statistics were available at the time this volume went to press.

<sup>3</sup> The area includes Connecticut, Delaware, District of Columbia, Massachusetts, Maryland, New Jersey, New York, Pennsylvania, and Rhode Island.

chief factors in our lumber markets. For many years they have been the chief competing species not only because of the volume represented but also because they are equally well suited for general construction purposes, for which the bulk of our lumber output is used.

### **Hardwood Markets.**

The chief center of hardwood production is in the lower valley of the Mississippi river, and in the Appalachian region. The bulk of this product moves north of the Ohio river and east of the Mississippi river to the wood-using industries, although some is distributed to the general building trade east of the Rocky Mountains. There is only a very small volume of eastern hardwoods shipped to the Pacific Coast because high transportation costs often do not permit shippers to compete, successfully, with Asiatic hardwoods, chiefly from Japan. Northern and eastern hardwoods, to a great extent, are used locally, and enter into competition with the lower grades from the southern territory. The best grades from the South are marketed successfully in all eastern centers.

About 85 per cent of the hardwood lumber of the country is sold in a territory roughly bounded by the States of Illinois, Indiana, Ohio, Pennsylvania, New York, southern Michigan, and southern Wisconsin. The decline in production of high-grade hardwoods in the East has gradually driven wood-using industries, dependent upon such material, nearer to the producing centers because of the high delivered cost of the better-grade stock, and also because of the excessive transportation cost on low grades, in the re-working of which there is a high percentage of waste.

### **Softwood Markets.**

The keenest competitive struggle in marketing lumber occurs in the softwood trade, especially in the lower grades which comprise a large per cent of the total output. "Common" grades of lumber are in greatest demand for general construction purposes and in lumber of this quality there is not a wide range of choice between southern yellow pine, North Carolina pine, Douglas fir, hemlock, and eastern spruce. The buyer is influenced in his choice of material largely by price. Figure 1 shows the location of the regions which have a surplus production of softwoods and the logical markets for each of these regions.

*New England.*—The New England group, which, in 1920, had a surplus equal to 0.9 per cent of our total lumber cut finds its chief market in New England and nearby points. The lumber is chiefly eastern spruce which is adapted for general construction purposes, crating, and other similar uses and competes with common grades of other softwoods, since

it is not adapted to the manufacture of high-grade mill products such as flooring, ceiling, and interior finish. It reaches the Boston market on local rates varying from 18 to 28 cents per 100 pounds which is about one-half of the rate from southern pine competing points. It reaches the New York markets on a 49-cent rate, about equal to the lowest rate from the southern yellow pine districts. This rate is  $11\frac{1}{2}$  cents higher than the lowest rail rates from the North Carolina pine region. Eastern spruce meets with strong competition in the New York market from Adirondaek spruce, which reaches New York on a 24-cent rate and West Virginia spruce which enters on a 35-cent rate. The importance of the New England spruce region as a source of sawed softwood products is rapidly declining because the high price which raw spruce material commands for pulp manufacture has raised the value of saw-log stumpage to a point where operators find it difficult to secure a reasonable profit in lumber manufacture in competition with woods from regions where raw material values are less.

*North Carolina Pine Region.*—The North Carolina pine region, comprising the states of Virginia and the Carolinas, has always found its chief markets along the Atlantic seaboard as far north as New England. The products have been marketed for many years in Baltimore, Washington, Philadelphia, New York, and other coast cities, because they could be reached by sailing vessels from Norfolk and other ports in the producing region. North Carolina pine has been an important construction and box wood but, in recent years, has not been a serious competitor of southern yellow pine mill work from the Gulf Region because, on the average, the quality of the product has not been as high. The freight rate from Norfolk, Virginia, to Chicago, Illinois, is 44 cents per 100 pounds,<sup>1</sup> and it is 42 cents from certain points in Mississippi, Louisiana, and some other interior southern yellow pine centers. The weight of North Carolina pine, per board foot, is less than that of longleaf or of shortleaf pine lumber produced in the Gulf Region and the actual freight cost, per thousand board feet, to the Chicago market is less on shipments from Norfolk than on those from southern yellow pine shipping centers which have a 42-cent rate. North Carolina pine does not move inland in large volume, however, even though the freight rate to Chicago is not prohibitive, because Atlantic coast markets can be reached at a lower freight cost, both by water and by rail. Lumber production exceeds consumption in these states by an amount equal to 2.4 per cent of the total production of the United States.

*West Virginia.*—Softwood products from West Virginia, chiefly hemlock and eastern spruce, are marketed chiefly in adjoining states to the North, although West Virginia spruce also is quoted in the New York

<sup>1</sup> Rates in effect on Oct. 1, 1921.

market. The volume of hemlock and spruce reported as cut in this state in 1919 was approximately 155,000,000 board feet, a quantity so limited that it was only a minor factor in the competitive markets.

*Lake States.*—Wisconsin was the only one of the Lake States which in 1920 produced more lumber than it consumed, the surplus being less than 1 per cent of the lumber cut of the country. The Lake States, therefore, are not self-supporting in sawed lumber although they ship some sawmill products to the surrounding states.

During the height of the lumber industry in this region, between 1879 and 1899, the product was distributed over the area north of the Ohio river from western Pennsylvania to the Mississippi river and westward through Kansas to Colorado and northward to the Canadian line. Previous to 1890 there was little competition from southern yellow pine or Douglas fir and the low price at which high-grade lumber was sold proved a great boon to the rapidly developing agricultural interests of the prairie states.

Lumber from the southern pineries began to move north of the Ohio river during the early "nineties" and became a keen competitor of white pine in the markets tributary to Chicago.

West Coast competition began to be aggressive about 1893, when trans-continental railroad lines made a through rate of 40 cents per 100 pounds from Seattle and other west coast points to the Minnesota Transfer. This rate also applied at that time to Inland Empire territory in which only a limited volume of lumber traffic originated.

The decrease in lumber production in the Lake States and the increase in home demand led to a gradual withdrawal of Lake States lumber from the more distant markets, except for specialized products, since there was greater profit in selling low-grade stock in home markets, which could be reached on a low freight rate, because they were so far removed from other large producing territories that the latter offered but little competition.

White pine is to-day marketed outside of the producing territory, but its limited volume and relatively high value have eliminated it largely from use in the cheaper forms of construction. It is, therefore, a less formidable competitor of southern yellow pine and Douglas fir in the prairie regions than eastern hemlock which now comprises a large part of the cheaper construction lumber produced in Michigan and Wisconsin.

*Southern Yellow Pine Region.*—The frontier line of the distribution of southern yellow pine lumber shipments runs from western Texas through eastern Colorado and Nebraska to South Dakota and eastward to the Atlantic seaboard. Mill products have reached a point as far

west as Salt Lake City, Utah, and some common grades have been shipped into the prairie regions of western Canada.

In the western half of this territory, Douglas fir has been a strong competitor, especially in those sections which can be reached from both regions on an approximately equal freight rate. The southern yellow pine region has been the dominating factor in the markets directly north of its territory because of the relatively low freight rates into that region. The eastern trade has purchased chiefly the higher-grade mill products, such as flooring, ceiling, siding, and finish which for a long time have had an established place in that region.

The shipments of southern yellow pine common lumber to the western frontier line in the prairie states have decreased in recent years owing to the increased home demand and the reduced volume produced in the pine region. Within another decade the local demands for southern yellow common lumber will require a very large proportion of the cut, and the chief products shipped outside of the producing states will be mill work for which a maximum price can be secured.

The strategic position of the yellow pine territory with reference to the Chicago market as compared to Douglas fir is shown by a comparison of the freight rates from producing points to that region. The average freight rate from southern yellow pine producing territory east of the Mississippi river to Chicago is  $39\frac{1}{2}$  cents per 100 pounds,<sup>1</sup> or \$11 per thousand board feet, on 12-inch common boards S 1 S or 2 S. From points west of the river the rate is 42 cents, or \$11.76 per thousand board feet. Douglas fir from West Coast points pays a rate of 70 cents per 100 pounds or \$17.50 per thousand board feet. This gives a differential in favor of southern pine of \$5.79 per thousand feet. The differential in favor of southern pine in the St. Louis market is \$9.29 and in the Buffalo market \$7.42. Northern hemlock from the Lake States which is a competitor of southern pine in the Chicago and other middle-western markets reaches Chicago from Northern Wisconsin on a  $20\frac{1}{2}$ -cent rate or \$5.12 per thousand board feet, and gets into Buffalo on a 42-cent rate of \$10.50 per thousand. This gives a differential in favor of hemlock of \$6.64 in the Chicago and \$4.20 in the Buffalo markets. Even with this difference in delivered costs in favor of hemlock, southern pine dominates the field because of its superior qualities and the large volume offered.

*Cypress.*—The greater part of the cypress lumber is manufactured along the Gulf Coast, chiefly in Louisiana. It also is cut in limited quantities in the upper delta of the Mississippi river and along the Atlantic Coast as far north as the Carolinas. On account of the durable character of the heart-wood, it is used for many purposes where

<sup>1</sup> Rates in effect January, 1922.

resistance to decay is desirable, and it is in demand in all portions of the United States. The largest volume, however, is sold to the general building trade in the Mississippi Valley region.

*Pacific Northwest.*—The territory in Oregon and Washington west of the Cascade Mountains produces most of the Douglas fir lumber manufactured, a limited quantity only coming from points south and east of that district. Western hemlock and Sitka spruce also comprise an appreciable part of the cut of this region. In 1913, 78 per cent of the lumber produced in the Northwest was consumed west of the Mississippi river, while in 1920 this had dropped to 55½ per cent.<sup>1</sup> Atlantic seaboard shipments<sup>2</sup> show an increase from 1.5 per cent in 1912 to 3.9 per cent in 1920. The per cent of shipments into the interior territory between the Atlantic seaboard and the Mississippi river showed little change during the two periods.

Exports to Canada, which were 3.44 per cent in 1912, dropped to 0.63 per cent in 1920, while all foreign consignments during the same period dropped from 9 per cent to 5.7 per cent.<sup>3</sup> Shipments into the southern pine territory increased from 0.057 per cent in 1913 to 0.4 per cent in 1920.

The trebling of the lumber movement to the Atlantic seaboard is due to less competition from southern yellow pine; to the expansion of the industry on the West Coast at a faster rate than local demands, which has forced the development of distant markets; to relatively low water freight rates; and to the sale of a better quality of lumber, for a given price, in Douglas fir than in southern yellow pine.

The stationary character of the trade in the interior, between the Mississippi river and the Atlantic seaboard states, is due to the keen competition offered in this territory by southern yellow pine, which has a more favorable rate into this region. The future trend of distribution will be towards a rapid increase in the volume of shipments to North Atlantic Coast points and a gradual increase in the interior states east of Chicago in which the influence of southern yellow pine is gradually decreasing owing to increased home consumption and a reduced output. The West Coast now dominates the trade of the United States in large-sized timbers since no other section can manufacture them in such large sizes and lengths. Southern yellow pine once produced large quantities of structural timbers, but stumpage suitable for this purpose

<sup>1</sup> These figures may not be strictly comparable since 25.7 per cent of the total shipments in 1920 were not classified by states.

<sup>2</sup> Includes all states bordering on the Atlantic Ocean from the southern boundary of Virginia northward to the Canadian line.

<sup>3</sup> These ratios are taken from a report by the U. S. Forest Service and are based upon 8288 million board feet sold in 1920. See West Coast Lumberman, May 15, 1921, page 36.

is now scarce and usually greater profits can be made by manufacturing it into other products.

The manufacture of shingles from western red cedar is an important industry in the states of Washington and Oregon, especially the former. In 1919 Washington produced 77.2 per cent of all shingles manufactured in the United States. Oregon was second, producing 5.8 per cent. They are shipped into every state in the Union the chief markets being in Illinois, Iowa, Kansas, Michigan, Minnesota, Missouri, Nebraska, and Texas.

*Redwood.*—Redwood lumber is produced in the extreme northern part of California and in southern Oregon. Sales are chiefly local, but some mill products and high-grade finishing material are sold throughout the northern part of the United States. The chief redwood demand, in the eastern part of the country, is for siding and for wide panel stock.

*Inland Empire.*—The territory known as the Inland Empire includes the states of Montana, Idaho, and that portion of Oregon and Washington east of the Cascade Mountains. Western yellow pine, Idaho white pine, Douglas fir, western larch, western red cedar, white fir, and spruce are produced in this region, although the first two woods comprise the major part of the cut.

Lumber manufactured in this region is marketed in the northern part of the United States west of the Mississippi river, large quantities being required for home consumption. Less than 20 per cent reaches the markets east of the Mississippi river, in which territory Wisconsin and Illinois purchase the largest amounts. No shipments are reported into southern pine territory.

The product which reaches the eastern part of the United States chiefly comprises stock which is substituted for eastern white pine in building construction, factory use, pattern making, and for similar purposes. Common grades of lumber from this region are sold almost exclusively in the home states and in the prairie regions.



## CHAPTER XIX

### FOREIGN MARKETS

#### EARLY FOREIGN MARKETS

THE shipment of the products of the forests of the United States to foreign countries became an important feature of our export trade early in the industrial life of the country. The vast forests of white pine and oak along the Atlantic seaboard contained raw material equal, if not superior, in quality to that available in Europe and from them the English early sought white pine ship masts and oak timbers for ship construction. Oak staves and hickory hoops also were in demand in the West Indies for rum casks and in the Madeira and the Teneriffe Islands for wine casks.

Southern yellow pine, known as "Georgia pine," was marketed in the West Indies and in England in the form of timbers, boards, and planks. The West Indian trade was in products suitable for house construction and ship building, while that of England was chiefly timbers which were used in dock and ship construction.

#### VOLUME OF THE EXPORT TRADE

The export trade in lumber and related products showed a gradual and steady increase from the beginning, with a few minor setbacks, until 1913, when the peak of foreign lumber shipments was reached. The total of sawed and hewed timbers, and of boards, planks, and scantlings exported that year was 3,063,650,000 board feet, which was 8 per cent of the lumber production of the United States. During that year 37 per cent of the volume of exports was shipped to Europe; 20.2 per cent to North American countries (Canada and Mexico); 18.3 per cent to South America; 6.7 per cent to the West Indies; 3 per cent to Asia; 2.1 per cent to Central America, and 12.7 per cent to other countries.

The volume of logs and other round timbers exported in 1913 was 160,000,000 board feet, 47 per cent of which was shipped to Europe, 46 per cent to North America (Canada and Mexico); and the remainder chiefly to Central America and the West Indies.

The chief exports of boards, planks, deals, and scantlings were southern yellow pine, Douglas fir, eastern spruce, eastern white pine,

TABLE XII.—EXPORTS OF HEWED AND SAWED TIMBERS AND BOARDS, PLANKS, DEALS \* AND SCANTLINGS † FROM THE UNITED STATES FOR THE CALENDAR YEARS 1913 TO 1920, INCLUSIVE ‡

Distribution	1913	1914	1915	1916	1917	1918	1919	1920
	1000 Bd. Ft.	1000 Bd. Ft.	1000 Bd. Ft.	1000 Bd. Ft.	1000 Bd. Ft.	1000 Bd. Ft.	1000 Bd. Ft.	1000 Bd. Ft.
Europe:								
Hewed and sawed timbers . . . . .	397,971	284,133	151,171	159,378	91,487	25,855	134,549	95,595
Boards, planks, deals, scantlings.	745,560	544,340	398,406	271,378	178,267	218,608	219,144	162,899
North America:								
Hewed and sawed timbers . . . . .	51,564	33,762	17,842	28,330	34,624	32,490	393\$	786\$
Boards, planks, deals, scantlings.	567,477	381,119	169,066	191,138	289,473	275,682	114,520	135,357
South America:								
Hewed and sawed timbers . . . . .	1,890	469	513	996	349	22	.....	1,497
Boards, planks, deals, scantlings.	514,356	208,988	159,985	140,592	139,447	128,314	147,030	208,855
West Indies:								
Hewed and sawed timbers . . . . .	.....	.....	.....	.....	.....	.....	.....	.....
Boards, planks, deals, scantlings.	206,935	133,713	147,512	239,605	202,877	216,719	188,923	6,223
Asia:								
Hewed and sawed timbers . . . . .	92,897	107,506	34,165	21,147	20,676	44,872	77,345	151,632
Boards, planks, deals, scantlings.	.....	.....	.....	.....	.....	.....	.....	.....
Central America:								
Hewed and sawed timbers . . . . .	67,249	73,557	38,853	65,306	27,216	24,968	30,689	33,366
Boards, planks, deals, scantlings.	.....	.....	.....	.....	.....	.....	.....	.....
All Others:								
Hewed and sawed timbers . . . . .	19,772	6,262	10,059	9,962	31,616	16,903	47,671	66,901
Boards, planks, deals, scantlings.	397,779	15,898	179,378	175,333	161,691	114,606	350,946	529,171
Total . . . . .	3,063,650	2,116,373	1,306,950	1,293,165	1,177,723	1,099,039	1,493,823	1,722,614

\* A piece 9 inches or more in width, and 3, 4, or 5 inches in thickness. † Pieces from 2 by 2 to 2 by 6 inches, 3 by 3 to 3 by 8 inches, 4 by 4 to 4 by 8 inches, and 5 by 5 to 5 by 8 inches. ‡ Based on data published in Monthly Summary of Foreign Commerce of the United States. Dept. of Commerce, Bureau of Foreign and Domestic Commerce. § Mexico not listed separately. || Not listed separately previous to 1920.

redwood, oak, gum and yellow poplar. The sawed timbers were mainly southern yellow pine and Douglas fir, and the hewed timbers were southern yellow pine and white pine. The "logs and other round timber" exports were largely oak, walnut, yellow poplar, hickory, and gum.

Exports of sawed products declined during the war, the 1918 shipments being 65 per cent less than those in 1913. The exports have been on the increase since 1917. In 1920 they were equal to 56 per cent of the 1913 shipments. The 1920 exports comprised 5 per cent of our total lumber cut, which was 1.8 per cent higher than the low point reached in 1916 and 1917.

The per cent relation between the volume of boards, planks, deals, and scantlings and that of hewed and sawed timbers is shown in Table XIII. This shows a decline in timber exports from 1913 to 1920 with an increase in the latter year.

TABLE XIII.—EXPORTS FROM THE UNITED STATES FOR THE CALENDAR YEARS 1913 TO 1920, INCLUSIVE

	1913	1914	1915	1916	1917	1918	1919	1920
	Per Cent	Per Cent	Per Cent	Per Cent	Per Cent	Per Cent	Per Cent	Per Cent
Boards, planks, deals, and scantlings.....	84.7	84.7	86.3	84.7	86.6	93.1	95.0	90.1
Timbers (sawed and hewed).....	15.3	15.3	13.7	15.3	13.4	6.9	5.0	9.9
Per cent of total lumber cut exported.....	8.0	5.7	3.5	3.2	3.2	3.4	4.4	5.1

In 1920 a marked change had taken place in the geographical distribution of our foreign shipments, the West Indies receiving 19.5 per cent, Europe 15 per cent, South America 12.2 per cent, Asia 8.8 per cent, North America 7.9 per cent, Central America 2 per cent, and not classified as to distribution 34.6 per cent. The West Indies, therefore, are now our chief foreign market, with a growing trade in Asia. European trade has fallen off 60 per cent in eight years, North American trade 61 per cent, and South American trade 33 per cent.

The chief increase in West Indian trade has been with Cuba, and in Asiatic trade with Japan. The decline in South America is due largely to smaller shipments to Argentine; in North America to greatly reduced shipments to Canada; and in Europe to a decline in shipments to the United Kingdom which, in 1920, were only 34 per cent as great as in 1913.

Log exports were 24 million board feet in 1918 and about 84 million board feet in 1920.

Canada has always been the largest importer of logs, taking about one-third of the 1913 shipment and 45 per cent of the 1918 shipment. Since the latter year, the destination of logs has not been reported by separate countries.

TABLE XIV.—DISTRIBUTION OF THE EXPORTS OF HEWED AND SAWED TIMBERS, AND BOARDS, PLANKS, DEALS, AND SCANTLINGS FROM THE UNITED STATES FOR THE CALENDAR YEARS 1913 TO 1920, INCLUSIVE.

Year	Europe, Per Cent	North America, Per Cent	South America, Per Cent	West Indies, Per Cent	Asia, Per Cent	Central America, Per Cent	All Other, Per Cent
1913	37.0	20.2	18.3	6.7	3.0	2.1	12.7
1914	39.1	19.6	9.8	6.3	5.0	3.5	16.7
1915	42.0	14.3	12.2	11.2	2.6	2.9	14.1
1916	33.3	16.9	10.9	18.9	1.6	5.0	13.4
1917	22.9	27.5	11.8	17.2	1.7	2.3	16.6
1918	22.2	28.0	11.6	19.7	4.1	2.2	12.2
1919	23.7	7.9	9.9	12.6	5.1	2.0	38.8
1920	15.0	7.9	12.2	19.5	8.8	2.0	34.6

This shift in the markets for American lumber has been due to various economic factors, in addition to the reduced exporting ability of the United States.

The increase in Cuban trade is due to the extensive development of the agricultural resources of the island brought about by the prosperous condition of the sugar industry during the war. Asiatic shipments, chiefly to Japan, are chiefly of logs and squares which are used in the construction of buildings and for the manufacture of buckets and tubs. The cessation of logging operations on Government lands in Formosa in 1920 is responsible at least for a part of our added trade with Japan. The decline in European trade is due, largely, to the unfavorable money exchange rates existing between Europe and the United States and to the disturbed economic conditions since the war. The decline in North American trade has been chiefly with Canada, which in 1913 purchased more than 500 million board feet of lumber and in 1920 less than 60 million board feet. This marked drop in sales to Canada is due to an increase in local lumber production, to very favorable home markets in the United States during 1919 and 1920, to an unfavorable rate of exchange, and to discriminating freight rates. The decline

in South American trade, chiefly with Argentina, is due to unsettled industrial conditions and unfavorable exchange rates.

#### EXPORT METHODS <sup>1</sup>

The export trade in lumber has been in the hands of foreign brokers, to a large extent, and they have been interested in creating markets for American lumber only in so far as they could sell it at a lower price than competing woods. The lumber manufacturers in this country have played only a minor part in the development of foreign trade. They have competed one with the other, because they have not had an effective organization to control distribution, and further they have not had a uniform basis for dealing with foreign purchasers, who are strongly organized.

At one time large export mills operated their own lines of sailing vessels and sold directly to brokers and importers in foreign countries. The number of mill-owned sailing vessels has decreased rapidly, however, because steamships have largely supplanted sailing vessels in the lumber carrying trade. This change in the type of carrier brought with it a change in the methods of handling foreign sales since steamer cargoes were larger than most individual mills were prepared to furnish and it became customary to split the cargo between several mills. The shippers of cargoes made up in this manner found it impracticable to deal directly with foreign importers, and consequently a need arose for the services of a middleman to assemble the cargo and to conduct the negotiations between buyer and seller. To-day foreign shipments of lumber are largely controlled either by export agents or by export merchants who may be found in the exporting sections of the country, especially in the Gulf Coast and in the Pacific Coast territories.

The export agent is a commission man who acts as an intermediary between an export merchant in the United States and a foreign broker or importer. It is the duty of the former to buy and assemble the necessary shipment and to arrange for tonnage, vessel clearance, and insurance. The export merchant usually has connections with foreign timber brokers to whom he looks for orders, which he later places directly with mills in this country or secures the necessary lumber through export agents.

There has been a growing tendency on the part of large export mills in this country, especially during the last few years, to deal directly

<sup>1</sup>See Cooperation in American Export Trade. Federal Trade Commission, Washington, 1916. Also, The Export Lumber Trade of the United States, by E. E. Pratt, Dept. of Commerce, Bureau of Foreign and Domestic Commerce. Miscellaneous Series, No. 67, Washington, 1918.

with the foreign brokers and importers. Some producers have established branch offices abroad to sell and distribute their product. This is regarded as the most satisfactory method, since it eliminates the middleman's profit, and enables the manufacturer to keep in close touch with foreign requirements. Some lumber, chiefly hardwood, is shipped on consignment, that is, it is forwarded to some foreign broker for disposal, previous to its actual sale. Such consignments often have a demoralizing effect on the market, because if a sale has not been made before the arrival of the shipment it must be put in storage, and the various charges incident to this operation may be sufficient to cause a loss to the exporter. Stored lumber is often sold at auction to the highest bidder and if the market is dull, the loss may be heavy. The chief ports to which lumber from the United States is consigned are London, Liverpool, Hamburg, Rotterdam, and Antwerp.

The local trade in European countries is handled, largely, through brokerage firms which have agencies in various cities, and which supply the importers with the products they desire. Some brokerage firms, especially in the United Kingdom, have a world-wide trade and deal, on a commission basis, in many kinds of wood. These brokers work in close harmony with the various co-operative buying combinations, which have a strong hold on the import trade of the countries in which they operate. These buying organizations also deal extensively in lumber manufactured in Sweden, Norway, Finland, and parts of the former Austro-Hungarian Empire. As a rule, they prefer to deal with these European countries since they are much nearer than the United States and also because the lumber manufactured in these countries is cut to the dimensions preferred by local consumers. There have been criticisms of lumber manufactured in the United States, one of these having reference to "scant sizes." The rules and customs of lumber manufacture in the United States give more latitude in sizes than is allowed in the softwood producing regions of northern Europe. Other criticisms relate to careless grading practice, failure to follow specifications, disregard of shipping instructions, and shortages in lumber cargoes.

A factor which operates in favor of foreign competitive softwoods is that wholesale prices for European products are more stable than those of shipments from the United States. In Sweden, Norway, and Finland a base price for the shipping season is made which is seldom deviated from throughout the year. The buyer of lumber in these countries is assured that early purchases can be made at a price which will prevail throughout the year, and hence competitors will not be able to secure stock during the latter part of the season at lower prices. American lumber, on the other hand, has no such fixed value, and there may be marked differences in price at various seasons of the year, due to transportation conditions

or to consignments made by shippers in this country, which often are sold in transit at a low price in order to avoid excessive storage charges at the destination.

The method of regulating prices in foreign lumber-producing countries may be illustrated by the Swedish Lumber Exporters' Association,<sup>1</sup> one of the most successful organizations of its kind in Europe. Similar organizations exist in Norway and in Finland and previous to the war a large co-operative organization of lumber manufacturers was in existence in Austria-Hungary, Rumania, and neighboring states. The Swedish organization has been in existence for many years and represents the shippers of more than 90 per cent of the lumber exports of the country. The mills outside of the association are small and the limited quantity of lumber produced is not sufficient in volume to affect the export association plan.

The chief object of the association is to fix and maintain a standard price on export lumber, a procedure not in violation of the laws of Sweden. This is done by a committee which sets minimum prices for each district, all members signing a contract binding themselves to observe the rules established by the association with reference to sales policy and minimum price. Failure to live up to the terms of the contract subjects the offending member to a heavy fine, which is collected through a financial guarantee which each member is required to establish in advance. Other activities of the association are, the maintenance of an arbitration force in importing countries to adjust claims against shipments; the maintenance of a freight bureau which keeps members informed regarding the freight market and also charters tonnage for members; an information service which, through a confidential magazine, keeps the members posted on foreign market conditions, prices, and stocks needed; a compilation of world-wide statistics regarding exports and imports; and an information service which keeps members informed on Swedish forest operations, floating, sawing, labor conditions, and other matters of interest to the manufacturers.

An attempt has been made to standardize the Swedish grading practice, but this has not proved successful because many of the manufacturers have long-established grades which are known to their customers, and a change would cause dissatisfaction with customers of many years' standing in foreign countries. The Swedish Lumber Exporters' Association is regarded as a semi-official organization and receives the moral support of the Government. The lumber trade is one of the most important forms of business in Sweden and the continued success of

<sup>1</sup>See *Swedish Forests, Lumber Industry and Lumber Export Trade*, by Axel H. Oxholm, Dept. of Commerce, Bureau of Foreign and Domestic Commerce. Special Agents Series, No. 195, Washington, 1921, pages 232 to 236.

the lumber industry is considered to be dependent upon the success of the association.

The South American trade, which until recent years has been of great importance, consists largely of southern yellow pine on the east coast and Douglas fir on the west coast. The greater part of the purchases on the east coast are made by importing houses, controlled by European interests, which do a general importing business. Purchases are made generally through London brokers or their American connections, sometimes through independent brokers in New York. Orders are rarely placed directly with the mills. Douglas fir purchases are made through brokers in San Francisco and Seattle who place the orders with the mills. The import lumber industry both on the east and the west coasts of South America, is controlled by a few firms, which from time to time have entered into mutual buying agreements.

The purchases in Australia, which are chiefly Douglas fir and redwood, are made through co-operative associations located in the various ports or in the consuming regions. The associations buy and distribute the imported lumber products.

The manufacturers and wholesalers in this country generally deal directly with the consumers in Canada.

The greater part of the export lumber trade to countries other than those mentioned is carried on by brokers, and the producer in this country is not in close touch with market demands.

#### LUMBER EXPORT TRADE CO-OPERATION

The lumber trade for many years was hampered in perfecting the organizations for co-operative marketing in foreign countries, by the restrictions placed upon corporations by the Sherman Anti-trust Act of July 2, 1890, which prohibited them from making agreements with reference to price, and from taking any other step which might be construed as operating in restraint of trade.

Notwithstanding this handicap, some co-operative export organizations were incorporated and had some measure of success in handling export sales and in studying foreign markets. The chief advantages sought by those who formed these co-operative organizations were economy in the development of foreign markets and in the creation of facilities for handling orders which were too large for individual mills.

One of the most serious obstacles to co-operative exports companies was removed when Congress passed the Webb-Pomerene Bill,<sup>1</sup> which

<sup>1</sup>The full text of this law may be found in *Export Trade of the United States*, by E. E. Pratt, Dept. of Commerce, Bureau of Foreign and Domestic Commerce. Miscellaneous Series, No. 67, Washington, 1918, pages 113 to 115.



was approved on April 10, 1918, making it lawful to organize corporations within the United States to engage in foreign trade without being liable under the Sherman Anti-trust Act, provided "That such Association does not, either in the United States or elsewhere, enter into any agreement, understanding or conspiracy, or do any act which artificially or intentionally enhances or depresses prices within the United States of commodities of the class exported by such association, or which substantially lessens competition within the United States or otherwise restrains trade therein."

Under this law it is legal to formulate price agreements and selling combinations for foreign trade, thus potentially placing the exporters on a more or less equal basis with those in certain competing countries of Europe. It is possible for export companies organized under this Act to undertake a systematic study of foreign market requirements and to establish closer relationships between the manufacturer in the United States and the consumer in other countries.

## EUROPEAN MARKETS

### Belgium.

The export lumber trade of the United States with Belgium has never assumed large proportions. In 1913 it was 2.1 per cent of our total exports of timbers and other sawed material and in 1920 it was 1 per cent. In the latter year, the shipments consisted of 3 million board feet of sawed pitch pine timbers and  $14\frac{1}{2}$  million board feet of boards, planks, deals, and scantlings. Log exports to Belgium were  $2\frac{1}{4}$  million board feet in 1913, with no report for 1920. During the years from 1915 to 1918, inclusive, no exports to Belgium were reported.

The chief Belgian imports from the United States are pitch pine timbers and oak and pitch pine boards, planks, deals, and scantlings. The chief sources of wood imports, previous to the war, were Russia, 39 per cent; Finland, 23.3 per cent; United States, 14.4 per cent; Sweden, 10.6 per cent; Germany, 5.7 per cent; Norway, 3.5 per cent; Japan, 2.4 per cent; and Australia, Austria-Hungary, Canada, and Rumania, 1.1 per cent. The chief importations since the war have been from Finland.

A large part of the lumber import trade in Belgium is in the hands of a co-operative association, known as the Syndicate of Lumber Importers of Belgium.

The decline in purchases from the United States, during recent years, is due to greatly decreased buying power on the part of Belgian customers and to the unfavorable rate of exchange which has existed since the close of the war. At the signing of the armistice several hundred million

board feet of Swedish lumber remained in Belgium, which was brought in by Germany, and in addition there was a large volume of hardwood logs cut by the German army in France and in Belgium. This stock was drawn upon to supply the immediate needs of the country. Various consignments of hardwood lumber have been shipped from the United States, but the demand for this stock has been limited and it has proved a disturbing factor in the market.

### France.

Although France normally imports a relatively large volume of logs and sawed forest products, she has never been an important customer of the United States. Statistics for 1920 show that about 8½ million board feet of timbers and boards, planks and deals were imported from the United States during that year, a quantity less than 0.5 per cent of our total exports of such material.

During 1913 France imported approximately 1.5 billion board feet of logs, timbers, and other sawed products, of which 29 per cent came from Finland, 27 per cent from Sweden, 25 per cent from Russia, 7.4 per cent from the United States, 6.4 per cent from Germany, 4.1 per cent from Austria-Hungary, and 1 per cent from Rumania, Norway, Japan, and Canada.

Her imports from the United States have been chiefly pitch pine timbers, boards, planks, deals, and scantling, and oak and other hardwood lumber. About 60 per cent of the lumber imports are between 1½ and 3½ inches in thickness, and 30 per cent less than 1½ inches. The pitch pine imports from this country are used for general industrial purposes, for public works, and for harbor and naval construction. Oak is used chiefly in the manufacture of furniture, interior trim, and specialized products. Pitch pine imports are handled largely by brokers and timber dealers in London, some of whom have branch offices in France. Hardwoods are often forwarded on consignment. Shipments are made both by full cargoes and by parcel shipments.

The chief lumber import centers are Bordeaux, Dunkirk, Havre, and Marseilles.

Since the war, France has purchased the major part of her import requirements from Finland.

### Germany.

The exports from the United States to Germany in the calendar year 1913 comprised 18 per cent of our total log exports, 3.7 per cent of our sawed and hewed timber exports, and 2.8 per cent of our boards, planks, and deals. From the outbreak of the war until 1920 exports to

Germany were *nil*. In 1921 small consignments of logs and some lumber were forwarded but the trade in lumber from the United States is still of small proportions as compared to the pre-war status, on account of the exchange and the unsettled political conditions which make buyers very reluctant to make purchases.

The previous log imports comprised walnut, which was used for gun butts, cabinet work, and furniture; yellow poplar for all forms of boxes, wood carving, toys, and high-grade furniture; hard maple for interior finish; oak for carriage work, furniture, and interior finish; cherry for wood carving, turning, and furniture; and hickory for carriage manufacture and for handles. The sawed material consisted chiefly of southern yellow pine (pitch pine) which was used for interior finish, flooring, and general construction. Some hardwood lumber and planks also reached the German markets.

The reported total annual pre-war German imports of logs, timbers, and other sawed products were in excess of 5 billion board feet, 3.1 per cent of which was from the United States. Russia furnished 46.7 per cent; Austria-Hungary, 37 per cent; Finland, 6.6 per cent; Sweden, 5.9 per cent; and Rumania, 0.7 per cent.

Hamburg was the chief port of entry for lumber, the business being handled by local brokerage firms. The "pitch pine" imports were controlled by three firms which also dealt in timber from the Baltic provinces, and in Douglas fir, redwood, spruce, white pine, and cypress. Nearly all sales of softwoods were made before the lumber left the United States, so-called consignment shipments being rare. Pitch pine reached Hamburg both by tramp and regular steamers from the ports of Galveston and Port Arthur, Texas; New Orleans, Louisiana; Gulfport, Mississippi; and Pascagoula and Pensacola, Florida. Pacific Coast products went by sailing vessel around Cape Horn or by steamer with trans-shipment at some Japanese port since the latter country had better steamer service with Germany than the West Coast of the United States.

Sales of American lumber usually were made through the European agents of American exporters who had headquarters in London, Hamburg, Liverpool, Rotterdam or Antwerp, although some German firms had agents in this country. These agents guaranteed delivery at Hamburg, charging a commission as high as 10 per cent of the invoice price, out of which commission they made good all losses resulting from inferior deliveries as established by a board of arbitration. Such a board consisted of one member appointed by each side with power to appoint a third member, whose decision was final, in case of the failure of the two to agree.

Local importers sometimes dealt directly with American shippers,

but this practice was not regarded as satisfactory because of the difficulty of collecting damages on faulty deliveries. Hamburg dealers maintained yards from which they made local sales, and also sales to dealers in other parts of Germany, Austria, and Hungary.

Hardwood sales were carried on through importers in Hamburg, who were equipped with lumber handling facilities, and who had business connections with shippers in the United States. Interior dealers secured their stock through these Hamburg importers. A factor which hampered direct dealings between shippers in the United States and buyers in the interior of Germany was the difficulty of securing through bills-of-lading. These could be secured through the larger steamship companies, but their charter rates usually were higher than those of tramp steamers. The most favorable rates to interior points were secured by barge shipments, rather than by rail; and the constant fluctuation of barge rates made a through-rate quotation rather difficult.

Lumber from the United States was sold for cash against shipping documents—that is, on presentation of the ocean bill-of-lading to the banker.

There were many parcel lots shipped on consignment, which often glutted the market on certain items and which had a demoralizing effect upon prices.

Lumber at Hamburg enters the customs “free zone,” and when finally sold the purchaser assumes the tariff duty. There were no lumber storage facilities on the wharves and shipments were allowed to stand forty-eight hours without charge. On the third day official charges began and these were so high that unsold lumber was usually removed to a lumber yard for storage. A large volume of hardwood was sold at private sales. Several large auctions also were held annually to rid the market of surplus stocks, most of them taking place under the direction of one brokerage firm which catalogued the lumber in storage and advertised the auctions through Germany, Austria, and Northern Europe. Buyers appeared at these auctions in person or by representation, one broker often representing several buyers. The seller was charged a fee for the auction service, which not only covered the auction charges but also the collection of the sale price from the buyer.

### **Holland.**

Russia in 1913 furnished more than 60 per cent of the log and lumber imports of Holland. The remainder came from Finland, 11.6 per cent; the United States, 11.2 per cent; Sweden, 7.5 per cent; Germany, 5.7 per cent; Rumania, 1.5 per cent; and Norway, Austria-Hungary, Japan, and Canada, 2.1 per cent.

Boards, planks, deals, and scantlings represented about 70 per cent of our total pre-war wood exports to Holland. The volume of timbers and other sawed material exported to Holland in 1920 was about 10½ million board feet, or approximately 7 per cent of the 1913 shipments to that country.

Hardwoods have been the chief log imports, among them being black walnut, oak, yellow poplar, ash, hickory, gum, and persimmon. The oak is used in ship building and for interior finish, while the other hardwoods are used chiefly by the various manufacturing industries. Some black walnut, gum, cottonwood, ash, and oak lumber also is imported.

Southern yellow pine (pitch pine) is the chief softwood secured from the United States. This comes largely in the form of sawed timbers, which are 6 by 9 inches or larger in cross-section. These are resawed to order by local mills. Pitch pine is used to a limited extent for flooring and finish in public buildings, but chiefly for piling, bridges, canal lock construction, and harbor works. It does not enter into general building construction, except on spans greater than 30 feet. The general building trade is supplied almost exclusively from Baltic products. Douglas fir is used to a limited extent for large timbers, joists, and framing for temporary structures but is not in as great demand as pitch pine, which is shipped directly from Gulf ports in parcel shipments and is sold to Dutch purchasers through English firms which have Dutch sub-agents in Rotterdam or Amsterdam.

### Italy.<sup>1</sup>

Lumber from the United States has been imported into Italy since 1867, at which time a cargo of southern yellow pine was marketed in that country. From 85 to 90 per cent of the present imports from this country are of the same kind of lumber, chiefly in the form of sawed timbers. Red gum is the wood next in importance. Small quantities of white oak, Douglas fir, yellow poplar, hickory, white ash, and white pine also have been sold in Italy. The chief competition which American woods meet in Italy is from Austrian shipments which in normal times have comprised about 80 per cent of the imports. The Baltic region and Germany also shipped limited quantities into Italy both by way of the Mediterranean Sea and the Black Sea.

Most of the shipments have been of the Genoa prime grade of southern yellow pine and No. 1 common grade of hardwoods. Southern yellow pine is used for general construction; car building and repair; mill work, such as interior finish, furniture, and office and store fixtures;

<sup>1</sup> See The Lumber Market in Italy and Reconstruction Requirements, Dept. of Commerce, Bureau of Foreign and Domestic Commerce. Special Agents Series, No. 182, Washington, 1919.

vehicle parts; and agricultural and electrical machinery. It is imported chiefly in the form of timbers and is resawed into the sizes desired. Red gum is used chiefly in the furniture trade. American oak is used for furniture, car construction, interior trim, flooring, vehicles, and machinery. Douglas fir is a comparatively new wood in Italian markets but has found favor in ship building, and general construction. Hickory and white ash lumber is used for vehicles and tool handles. Cottonwood, tupelo, yellow poplar, maple, eastern white pine, and California sugar pine have been imported in small quantities for special uses, but a stable demand for them does not exist.

Lumber shipments from the United States to Italy formerly were routed through German, Dutch, and English ports where they were trans-shipped. The trend of the trade since the war has been towards direct shipments, with settlement through American banks in Italy and branch Italian banks in the United States.

American deals usually are sold in Italy on the basis of the St. Petersburg standard, although some direct shipments are on the basis of the thousand board feet. Timber purchases often are handled on the English "load" basis (50 cubic feet), the cubic-foot average of the shipment being taken into consideration by the importer and purchaser in fixing the price. Genoa is the chief port of entry and distribution for United States lumber products. Italian importers purchase very little dressed lumber, the rough products being reworked by local wood-working establishments.

### Portugal.<sup>1</sup>

The chief lumber imports from the United States are of southern yellow pine, which in normal times amounts to approximately 9 million board feet. Small quantities of white oak and red gum also are handled. The lumber trade is conducted by middlemen. Softwood shipments are made chiefly in cargo lots on sailing vessels and steamers and hardwoods in parcel lots on the regular steamer lines. The chief uses for woods imported from the United States are for box boards, house construction, and boat building. The chief competition which United States shippers meet in Portugal is from the Baltic region in Europe and from home supplies.

### Spain.<sup>2</sup>

In 1913 Spain received only 3 per cent of our exports of timbers and boards, planks, and deals. Spanish purchases from us are chiefly deals

<sup>1</sup> See *Lumber Markets of Spain and Portugal*, by N. C. Brown, Dept. of Commerce, Bureau of Foreign and Domestic Commerce. Special Agents Series, No. 201, Washington, 1921.

<sup>2</sup> See *Lumber Markets of Spain and Portugal*, by N. C. Brown.

of "merchantable" quality, 80 per cent of which are southern yellow pine. A small per cent of her imports from this country are sawed timbers of southern yellow pine and Douglas fir, and oak and gum from 1 to 4 inches and ash from 2 to 4 inches in thickness.

The southern yellow pine in the larger sizes is used for construction purposes in and around factories, mining operations, railway terminals, docks, and wharves. The smaller sized deals are used for general building purposes, chiefly for joists, rafters, floor beams, and other places where strength and durability are essential. Southern pine is also used in car construction and as flooring in the better class of public buildings. Oak is used for high-grade furniture and cabinet work, high-grade flooring, car construction, and interior trim. Red gum is used chiefly for furniture and cabinet work; white ash for the construction of cars, vehicles of various sorts, tool handles, and furniture; Douglas fir for general construction purposes; and black walnut for high-grade furniture, cabinet work, gun stocks, and wood carving. Very small quantities of hickory, maple, basswood, beech, birch, tupelo, cypress, redwood, white pine, California sugar pine, and Idaho white pine have been imported in the past but are not important species in the Spanish markets.

The lumber sales from the United States are made chiefly through exporters and agents located both in this country and in Liverpool and London. The manufacturer seldom deals direct with buyers, although there are some agents located in this country who represent Spanish buyers. A large part of the business is done through English timber agents. Payment for American lumber is generally made on the basis of confirmed credit by London bankers. Sales of southern yellow pine also have been made on the basis of the St. Petersburg standard c.i.f., Spanish ports of delivery.

The customs charges on surfaced stock are prohibitive, in most cases, and are designed to protect the local wood-working establishments. The duty on deals, battens, timbers, and boards in the rough are assessed on the basis of the cubic meter, while veneers, cross ties, staves, fine cabinet woods, and other manufactured forms are assessed on the unit of 100 kilos.

A large part of the lumber consignments to Spain is brought in full cargo shipments, either by steamers or sailing vessels. Direct parcel shipments by steamer are confined to hardwoods.

Baltic softwoods, Austrian oak and spruce, and French, Portuguese, and local supplies of rough pine for box boards furnish the chief competition with lumber imports from the United States.

### **The United Kingdom.**

The United Kingdom imports about 84 per cent of its wood require-

ments. In 1913 the total imports of sawed material from all countries were approximately 4 billion board feet of which 190,000,000 board feet were dressed stock and 557,000,000 board feet were sawed and hewed timbers.

The United States shipped to the United Kingdom during the calendar year 1913, 201,605,000 board feet of sawed and hewed timbers, 354,197,000 board feet of boards, planks, and deals, and 159,931,000 board feet of logs and round timbers. In 1920 the imports, from the United States, of sawed timbers were only 71,000,000 board feet and those of boards, planks, and deals, were 118,236,000 board feet. The timbers comprised 42.8 per cent of our total exports of that class of material in 1913 which was far in excess of the quantity shipped to any other country, Italy being second, receiving 11.8 per cent. The per cent relation in 1920 remained unchanged for the United Kingdom, but the volume shipped to Italy was greatly reduced. As a customer for boards, planks, and deals, the United Kingdom was second, taking 13.2 per cent, Canada being first with 18.2 per cent. The United Kingdom also was our second best customer for logs, receiving 12.9 per cent of the total log shipments, Canada being first, taking 35 per cent.

The United Kingdom continues to be the largest importer of sawed and hewed timbers produced in the United States, but it has fallen to second place in boards, planks, and deals, exports to Cuba being more than twice those to the United Kingdom.

The marked drop in our lumber trade since 1913 is due probably to a constantly increasing volume of imports from Canada and to the gradual revival of trade in lumber with Russia. In 1918 Canadian imports into the United Kingdom were 12 per cent greater than those from the United States, while in 1920 they were 80 per cent greater. The Russian imports into the United Kingdom also were sixteen times greater in 1920 than in 1918 and exceeded those for the United States by 160 per cent.

The sawed and hewed timber imports from this country were largely southern yellow pine; boards, planks, and deals were southern yellow pine, Douglas fir and spruce; and logs were chiefly black walnut, yellow poplar, gum, hickory, ash, and oak. The southern yellow pine and Douglas fir are used for general construction purposes and spruce for box material. The hardwoods are used for manufacturing purposes, furniture, car and vehicle construction, and spool stock.

The chief competitive woods are from the Baltic region, which has claimed the United Kingdom as one of its chief markets for many years. The general quality of the stock from this country is superior to that from the Baltics, but the United States trade is not as well organized and shippers have not been able to secure much benefit from this factor.



The measurement in common use in the English timber markets is the St. Petersburg Standard Hundred of 165 cubic feet or 1980 board feet for deals, boards, and battens and the "load" (50 cubic feet) for sawed and hewed timbers. The price of the latter, when shipped from the United States, usually is based upon the cubic-foot average of the various pieces comprising the consignment.

The transactions usually are conducted in the following manner. A shipper in the United States contracts to deliver, within a specified time, certain lumber of a particular grade or grades and specifications at a given price per foot, c.i.f., at a particular port or ports. The transaction is conducted through an agent, who also arranges the terms of payment. Some shippers have attempted to have direct dealings with customers, thus eliminating the agent; merchants also have made efforts to deal with shippers; and agents have undertaken to deal with the consumer and eliminate the importing agent. None of these schemes has met with much success and have not become well-recognized practices.

In the Liverpool market, which is more or less typical of conditions in the United Kingdom, the business is handled through brokers or selling agents, and merchants or dealers. The function of the brokers is to act for shipping firms for which they are the agents. They undertake to make sales on a commission basis, the commission covering sales and also a guarantee of payment for such transactions as they originate. The local merchants or dealers usually are large lumber-yard owners who purchase chiefly from brokers.

Sales are made on one of three bases, namely, (1) c.i.f.; (2) ex-quay; (3) yarded or stored. Most large transactions, which usually come in cargo lots, such as southern yellow pine from the United States are handled on the c.i.f. basis, while parcel lots, especially of hardwood, often are handled on the "ex-quay" basis. The latter method of purchase is preferred by merchants. When sales are made "ex-quay," the product is invoiced on the basis of the selling broker's measurements, the shipper paying landing charges. The buyer, however, removes the product from the quay at his own expense. The "yarded or stored" terms are applicable to consignments of wood products which brokers have put into storage. The owner pays landing charges, the cost of removal from the quay to storage yards, and also the storage charges. This practice is resorted to only under exceptional circumstances, owing to the heavy handling charges.

For many years long credit has been the general custom in the timber trade of the United Kingdom. Brokers give merchants six months' credit, without collateral security and retail merchants in turn give customers a long-time credit. Brokerage firms, therefore, must be

strong financially since shippers often draw sight drafts on them on short notice.

The dock system at Liverpool is under the charge of a Docks and Harbor Board. As timber and lumber is received from vessels it is sorted out by marks and conveyed to specified places on the quay by master porters who are appointed, officially, by the Board. The latter charges for this portage and also levies a special fee for goods going over the dock estate.

Most of the lumber products bought on a c.i.f. or an ex-quay basis are stored at the purchaser's yards from which it is distributed to customers. Some brokers have storage yards, but these are used chiefly for mahogany and other stocks which generally are not sold ex-quay.

There are no official measurers or inspectors connected with the timber trade in Liverpool. Brokers have inspectors in their employ and they measure all consignments handled by the firm. This inspection is sometimes accepted by merchants, but as a rule they have a member of their own staff inspect the lumber at the time the broker's inspection is made. The broker's fee for inspection varies with the class of wood inspected.

Disputes between shippers in the United States and the brokers or merchants are settled by arbitration, broker's contracts carrying an arbitration clause which, in case of dispute, provides that buyer and seller shall each appoint an arbitrator. These two appoint an umpire who acts in case the two arbitrators fail to agree. Private settlement of disputes is usual, although cases are sometimes carried to the courts for adjustment.

## NORTH AMERICAN MARKETS

### Canada.

The importance of Canada as a market for lumber manufactured in the United States decreased during the period from 1913 to 1920. In the former year we exported to the Dominion approximately 56 million board feet of logs, 44 million board feet of sawed timbers, and 472 million board feet of boards, planks, and deals. In the latter year no log exports were recorded and only 786,000 board feet of pitch pine sawed timbers and 53 million board feet of boards, planks, and scantling, a total loss of 90 per cent in a period of eight years. The small shipments in 1919 and 1920 were due in large part to the excellent home markets and to increased production of softwoods in Canada.

The chief exports to Canada in 1920 were oak boards, planks, and scantling which comprised 78 per cent of the total shipments. Douglas fir boards, planks, and scantling comprised 18.5 per cent, and southern

yellow pine timbers and boards the remainder. The bulk of the hardwood exports go to factories in eastern Canada, southern yellow pine also goes to that section and Douglas fir to the prairie region of western Canada. Southern yellow pine formerly was used extensively for railroad and dock purposes, and car construction. This trade has now been absorbed largely by Canadian products from the Pacific Coast.

Cross ties for railroads have formed an important export to Canada for some years. In 1920 more than  $1\frac{1}{4}$  million pieces, or 20 per cent of the total cross tie exports, were shipped to the Dominion and in 1918 and 1919 the quantity exceeded  $1\frac{1}{2}$  million pieces per year. The only other country which imports a larger quantity from the United States is the United Kingdom.

Sales in Canada usually are made directly to the local distributing agencies or to large consumers, brokers playing only a limited part in the distribution of forest products from this country.

### **Mexico.**

Although certain portions of Mexico are well timbered, this country has imported considerable lumber, chiefly boards, planks, and scantling, from the United States. Native lumber is used by the mining interests, wherever it can be readily obtained from forests in the vicinity of the operations.

The woods imported from this country are southern yellow pine, Douglas fir, oak, beech, maple, and ash. Railroad ties also are imported in relatively large quantities. The most important industries in Mexico using timber from the United States are the railroads which buy construction timber and car material, and the mining industry and the petroleum industry, which rely largely upon timber from this country for derricks and other structural purposes.

The chief softwood imports are southern yellow pine, which in 1920 comprised about 90 per cent of the total boards, planks, and scantlings shipped to Mexico. A small quantity of Douglas fir lumber was also shipped to Mexico during that year. Hardwood exports to Mexico are not reported. Their chief use is for furniture manufacture.

Log exports to Mexico were about 18 million board feet in 1913, and  $6\frac{1}{2}$  million board feet in 1918. Sawed timber exports in 1913 were about  $17\frac{1}{2}$  million and in 1918, 20 million board feet.

Some years ago an extensive development of the western yellow pine forests was begun in Chihuahua, Mexico, and shipments were made to the United States through El Paso, Texas. The Mexican revolution caused a cessation of work and the sawmill and other plants at Madera, Chihuahua, were almost totally destroyed by marauding parties. The

properties have not yet been put into operating condition but in the future they may prove to be an important competitor of southern yellow pine produced in the United States.

#### SOUTH AMERICAN MARKETS

##### **Argentina.**

Among the South American republics, Argentina has been the chief market for lumber exports from the United States, nearly 80 per cent of the lumber used in Argentina and Uruguay coming from this country. During the calendar year of 1913, Argentina imports of logs, sawed and hewed timbers, and boards, planks, and deals from the United States were approximately 310 million board feet of which boards, planks, and deals comprised more than 99 per cent. In 1920, 109½ million board feet were reported as being exported to Argentine. Trade declined rapidly during the war, the volume in 1918 being less than 10 per cent of that in 1913, due largely to a lack of shipping facilities and to unsettled business conditions in Argentina.

Southern yellow pine has always furnished the greatest volume of softwood imports, limited quantities of spruce, white pine, and Douglas fir also being purchased. Oak, ash, and walnut comprise the bulk of the hardwoods shipped to Argentina from the United States. Yellow pine is moved to Argentine ports both in steamers and in sailing vessels and is shipped chiefly from Gulfport, Mississippi; Mobile, Alabama; and to a lesser extent from Port Arthur and Sabine Pass, Texas, and Pensacola, Florida.

Spruce is forwarded chiefly from Philadelphia, Baltimore, and Norfolk; white pine from Boston; Douglas fir from North Pacific ports; and the hardwoods from Baltimore, Norfolk, and New Orleans. Southern yellow pine is purchased in dimensions similar to those used in the United States for general construction purposes; the white pine in 12-inch widths; spruce in assorted widths and thickness; and hardwoods from 1 to 4 inches in thickness and 6 inches or more in width.<sup>1</sup>

The chief competition our softwoods meet is from shipments from the Baltics and from Brazil.

Although the metric system is the legal standard of measurement in Argentina, the board foot is the measure most commonly used in actual practice since cargoes of timber are measured and invoiced in accordance with the system used in the country of origin. Thus cargoes from the

<sup>1</sup> A schedule of dimensions for these markets is given in *Lumber Markets of the East Coast of South America*, by R. E. Simmons, Dept. of Commerce, Bureau of Foreign and Domestic Commerce. Special Agents Series, No. 112, Washington, D. C.

United States are billed in board feet and those from the Baltics in the St. Petersburg Standard Hundred. The Government has licensed inspectors whose measurements are accepted both by the importer and by the customs service in levying duties. A specified fee is charged for inspection work, the amount varying with the species.

One of the methods of purchasing lumber from this country is through firms doing a general import business which maintain purchasing agents in the United States and which contract for lumber stocks either with brokers or with manufacturers. Import transactions between independent importers in Argentina and exporters in the United States is not unusual.

There has been more or less dissatisfaction in the past with lumber imports from this country owing to discrepancies which have existed between the bill of lading and actual measurement at port of entry. This is reported as applying especially to southern yellow pine shipments. Owing to rigid customs regulations, these discrepancies often led to the imposition of fines against the importer.

Argentina will undoubtedly remain an important market for southern yellow pine, but trade conditions may be improved by more careful attention to shipments on the part of exporters in the United States.

### **Brazil.<sup>1</sup>**

Brazil ranks second in importance among South American countries as a market for lumber from the United States, in 1913, receiving 2.7 per cent of our exports of boards, planks, and deals. No exports of logs and timbers were reported. Of her total imports in 1913, more than 90 per cent came from the United States.

Southern yellow pine shipped from Gulf ports is the chief wood imported, the greater part of which enters the port of Rio de Janeiro. White pine and eastern spruce are also in demand in limited quantities. The chief competition with softwoods is from imports originating in the Baltic region.

About three-fourths of the southern yellow pine imports are in the form of 3- by 9-inch deals, about one-third of which are more than 30 feet in length.

The metric system is the established standard of measurement in the lumber trade, but the board foot is extensively used in Rio de Janeiro and in other coast cities of southern Brazil and is the system by which lumber from the United States is measured and invoiced. Shipments

<sup>1</sup> See *Lumber Markets of the East Coast of South America*, by R. E. Simmons, Dept. of Commerce, Bureau of Foreign and Domestic Commerce. Special Agents' Series, No. 112, Washington, 1916.

from the Baltics are measured and invoiced on the basis of the St. Petersburg Standard Hundred.

The transactions relating to lumber imports are largely conducted by import and export brokers or agents. The exporter at the port of shipment arranges for the purchase and shipment of the consignment, which upon arrival at destination, is taken in charge by the importer, who makes arrangements for discharge of the cargo, payment of freight, customs, and other charges and for the settlement of the account with the person who receives the goods. The agents, both import and export, are not necessarily independent concerns since the exporter may have his own agent act as importer and vice versa.

The chief uses for southern yellow pine in the markets of Rio de Janeiro are for rough construction, flooring, interior trim, car construction, and boxes, while white pine is used for foundry patterns, interior finish, and by the wood-using industries.

### Chile.

More than one-half of the total volume of lumber consumed in Chile is secured from the United States. During the calendar year 1920 approximately 23 million board feet were imported from this country, a very large proportion of which was Douglas fir. Small quantities of white pine, sugar pine, redwood, oak and other hardwoods are also sold in the Chilean markets.

The chief demand for United States lumber is in the northern part of Chile where it is used in general construction and in the mining and nitrate industries. The product is imported in dimensions used in the domestic markets of this country, and is measured and invoiced on the board-foot basis.

Most of the lumber purchases are made through corporations engaged in a general export business, along the west coast of Central America and of South America and also in the Far East. A home office is maintained in New York, London, or some other large city, through which orders are placed. Branch offices in the importing countries supervise the discharge of the cargo and conduct the financial transactions at the destination.

Lumber is usually handled in connection with general merchandise, some firms maintaining lumber departments in charge of men familiar with the lumber trade.

The local supply of lumber, chiefly hardwoods, is used for general construction purposes, and on account of the lower prices at which it is sold, competes with lumber from the United States for cheap structures.

**Peru.**

About 93 per cent of the total volume of lumber consumed in Peru is secured from the United States. Our exports to that country for 1920 were 57 million board feet, of which Douglas fir comprised about 80 per cent. The remainder of the imports from this country comprised small quantities of redwood, Sitka spruce, sugar pine, western white pine, southern yellow pine, oak, ash, yellow poplar, and walnut. Douglas fir ranging in size from 6 by 6 inches and larger in cross-section and from 16 to 34 feet in length is used for sash, door, and blind manufacture, interior trim, farm buildings, and for mining purposes. Thinner material also is imported for re-manufacture into mill work. Sitka spruce is purchased in thicknesses ranging from 1½ to 2½ inches, and is re-sawed and worked into box stock, ceiling, car siding, and boat parts. Redwood and sugar pine are received in the form of boards and planks and are used in the manufacture of sashes, doors, and blinds, mill-work, patterns, and car construction.

The largest users of lumber are the mines, farms, and railroads.

The import transactions are carried on through middlemen who sell to dealers in cargo and parcel lots, and to large consumers, such as mines, railroads, and plantations. Sales are usually made on the basis of future delivery, since few importers carry any stocks on hand. All lumber imports are measured and invoiced on the board-foot basis.

Orders for lumber are placed with mills in the United States by American exporting firms, which are also importers in Peru. A large part of the Peruvian lumber trade is under the control of one firm, which operates a steamship line between the United States and the South American Republics on the West Coast. Some schooner cargoes are also received, but sailing conditions are not favorable for this method of transportation and consequently it is of much less importance than the steamer trade.

## WEST INDIAN MARKETS

**Cuba.**

The demand in Cuba for lumber from the United States was greater in 1920 than in any other of the Central or South American countries, the exports being nearly three times greater than to Argentina, which ranked second. Boards, planks, and scantling have always been the chief form of product purchased, the volume in 1920 being 272 million board feet. Previous to 1920, sawed timbers were not reported separately for Cuba, but in this year the shipments were 6,223,000 board feet. Log exports to Cuba have not been reported since 1918, in which year they were 409,000 board feet.

Southern yellow pine from the Gulf ports formed 95 per cent of the exports of boards, planks, and scantlings to Cuba in 1920, Douglas fir representing the remainder. In addition 758,000 cross-ties were imported. The lumber products from the United States are used for general construction purposes, for ship, barge, and car construction, and for furniture.

Small quantities of white pine and eastern spruce are used in Cuba, but these come largely from Canada.

Lumber is brought to Cuba by sailing vessels in cargo lots ranging from 250,000 to 400,000 board feet. It is sold through importing houses in Havana, buyers seldom dealing directly with the shipper. The prices quoted usually are on a c.i.f. basis.

Cuba undoubtedly will remain one of the chief foreign markets for southern yellow pine, owing to its proximity to the producing centers in the Gulf States, and to the fact that the local softwood production is inadequate to supply the heavy demands for this class of material both for public construction and for plantation improvements.

#### ASIATIC MARKETS

##### China.

China imports annually from 100 to 200 million board feet of softwoods and from 2 to 4 million cubic feet of hardwoods. The chief sources of the imported softwoods are the United States and Japan, the former country shipping 93 million board feet of boards, planks, and deals in 1913 and nearly 89 million feet in 1920. The hardwood imports are chiefly from Japan and the Philippine Islands.

Douglas fir comprises the greater part of the imports from the United States, being shipped in the form of boards, planks, and timbers. It is used chiefly in the ports of China in the ship-building plants, for dock construction, railroad construction, and general building purposes. A small quantity of redwood also is imported for general construction purposes.

There is no market for lumber from the United States in the interior cities, which have no rail connections with the seaboard.

Sales of lumber from the United States are made through importing houses in the Chinese ports, which deal directly with the Chinese retail lumber merchant. This market has no special predilection towards our lumber, but is interested chiefly in price and has purchased our lumber in the past largely because no other timber of the same quality could be obtained at the same price.



## Japan.<sup>1</sup>

Japan is not a heavy importer of lumber, relying mainly upon its own forest resources to supply the domestic demand. In 1913 the total lumber imports were about 20 million board feet, about 80 per cent of which was Douglas fir from the Pacific Coast. The chief imports at that time were in the form of timbers of long lengths and large dimensions, which could be purchased in the United States and delivered at a lower cost than material of the same quality and size could be secured from local forests. The greater strength of Douglas fir, as compared to competing local species, is sometimes a deciding factor in structural work. Recent export statistics show a growing trade in boards, planks, and scantling, the volume of Douglas fir in 1918 being 31 million board feet and in 1920, 63 million board feet. One reason for the increase in the imports of boards is that wages in Japan have increased and the cost of whip-sawing lumber has become almost prohibitive.

Japan does not use a great deal of lumber in house construction and, therefore, does not require a large amount of lumber for general building purposes.

The lumber imports from the United States are brought largely in cargo steamers in lots of from 150,000 to 300,000 board feet and landed at Yokohama, Kobe, Osaka, or Nagasaki, from which points it is distributed by rail to the various consuming centers.

Purchases of lumber seldom are made directly by the consumers, the orders usually being placed through foreign importing firms located at the chief ports, which deal with the shippers in the United States.

## OCEANIA MARKETS

### Australia.

Lumber consumption in Australia in 1913 was approximately one billion board feet, about one-half of which was imported. In 1918 consumption had dropped to less than 600 million board feet, and imports to about 170 million board feet. About one-half of the imports during recent years have been from the United States and have consisted almost entirely of Douglas fir, the volume of which, in 1920, was about 72 million board feet. Australia also has imported from the United States, redwood, spruce, white pine, southern yellow pine, oak, and yellow poplar.

Other countries from which lumber is secured are New Zealand, Norway, Sweden, Canada, Japan, and Russia. The imports from Norway

<sup>1</sup> See Japanese Markets for American Lumber, by Franklin H. Smith, Dept. of Commerce, Bureau of Foreign and Domestic Commerce. Special Agents' Series, No. 94, Washington, 1915.

and Sweden declined greatly during the war and were practically *nil* from 1916 to 1918. There was no lumber trade with Russia during the years 1916 to 1918, inclusive, and practically none in 1915.

The bulk of our exports to Australia are in the form of rough lumber and timbers, because of the high customs duties on dressed stock. Most of the latter class of material has been secured from Sweden, Norway, and Canada.

Timber transactions are made chiefly through brokers, who have representatives in the larger cities of Australia. The main brokerage houses have connections with firms in San Francisco, London, Norway, Sweden, Germany, and Russia. Most of the business is done on a commission basis.

Douglas fir is used for general construction purposes. It will always be in demand because of its relative cheapness, strength, durability, ease of working, and light weight as compared to Australian hardwoods. Redwood is used in the manufacture of mill work, including sashes and doors.

The market for American hardwoods is very limited, due to competition of local species, and such shipments as have been made have been consigned to furniture manufacturers who find difficulty in securing properly seasoned local stock.

## CHAPTER XX

### IMPORT TRADE—LUMBER TARIFF

#### IMPORTS

#### Kind.

The forest products imported into the United States are logs, timbers, lumber, shingles, laths, pulp wood, wood-pulp, dyewoods, barks, gums, resins, India rubber, gutta-percha, naval stores, and tanning materials of which India rubber and gutta-percha represent a large per cent of the total monetary value of our forest products imports.

#### Volume.

The imports of logs, timbers, and sawed products for the calendar years 1913 to 1920, inclusive, are shown in Table XV.

TABLE XV.—LOG AND LUMBER IMPORTS INTO THE UNITED STATES FOR THE CALENDAR YEARS 1913 TO 1920, INCLUSIVE

Year	Logs and Other Round Timbers		CABINET WOODS				Boards, Planks, Deals and Other Sawed		Total
			Unmanufactured		Boards, Planks, Deals and Other Sawed				
	1000 Board Feet	Per Cent of Total	1000 Board Feet	Per Cent of Total	1000 Board Feet	Per Cent of Total	1000 Board Feet	Per Cent of Total	
1913	144,482	7.3	88,538	7.3	(*)	.....	968,509	80.5	1,201,521
1914	132,259	11.8	72,507	6.5	8,593	0.7	910,509	81.0	1,123,868
1915	166,587	13.0	49,151	3.9	12,896	1.0	1,047,415	82.1	1,276,049
1916	126,271	8.95	56,596	4.0	16,483	1.16	1,210,913	85.9	1,410,263
1917	103,154	7.6	61,767	4.5	5,212	0.4	1,198,388	87.5	1,368,521
1918	33,659	2.6	53,207	4.2	2,885	0.2	1,206,027	93.0	1,295,778
1919	93,356	7.2	50,261	3.9	3,758	0.3	1,144,187	88.6	1,291,562
1920	76,212	5.1	60,861	4.1	9,754	0.7	1,338,530	90.1	1,485,357

\* Not reported separately previous to 1914.

During the period covered by this table, the imports of boards, planks, deals, and other sawed material comprised from 80 to 93 per cent of the total volume. Logs in 1913 comprised 12 per cent of the total volume, but this had shrunk to 5.1 per cent in 1920. Cabinet woods comprised 7.3 per cent of the total volume in 1913 and 4.8 per cent in 1920.

### Source.

Data showing the source of our imports are available for the years 1913 to 1918, inclusive, but since the latter year only the imports for mahogany are segregated by countries. In 1913 the imports from North America, chiefly Canada, were 95 per cent of the total, the remainder coming from Europe, Africa, Asia, Oceania, and South America. In 1918, 98.7 per cent came from North America, chiefly Canada and the remainder from Africa, South America, Oceania, and Europe. The importance of Canada, therefore, is increasing as she now furnishes fully 99 per cent of our imports of boards, planks, deals, and other sawed material, which consists of eastern white pine, eastern spruce, Douglas fir, hemlock, and practically the entire volume of shingles and laths. The trade has grown rapidly during the last forty years, because of the increased demand for lumber in the eastern part of the United States, where agricultural and industrial development has been accompanied by the depletion of the local forest resources.

The imports from Canada of boards, planks, deals, and other sawed material were lower during the fiscal year 1898 than in any year subsequent to 1879. This rapid decline was due mainly to the passage of the Dingley Tariff Act, which went into effect on July 24, 1897, and which removed lumber from the free list and imposed an import duty of \$2 per thousand board feet on rough sawed lumber of all species, except whitewood, sycamore, and basswood. There has been a rapid increase in the importation of boards, planks, deals, and other sawed lumber since 1898, the average annual increase being 13.6 per cent per fiscal year up to and including 1916. During the fiscal year 1920 the imports of boards, planks, deals, and other sawed lumber were the highest in the history of the country, approximating 1 billion board feet.

A large volume of white pine is removed by the Great Lakes from the Georgian Bay territory of Ontario to the wholesale centers tributary to the Great Lakes, and much eastern spruce has been shipped from New Brunswick, Nova Scotia, and Quebec into the New England and New York markets. This lumber was handled by American wholesale lumber merchants who mixed it with the product from American mills and distributed it without regard to origin.

Boards, planks, deals, and other sawed material have entered the

United States chiefly through the customs districts of the St. Lawrence, Buffalo, Maine and New Hampshire, Vermont, Michigan, and Duluth and Superior.<sup>1</sup> Only relatively small quantities have come in through Atlantic Coast ports or along the western boundary. Logs and other round timbers, exclusive of pulpwood, have come in chiefly through the customs districts of Maine and New Hampshire, Vermont, and Washington. Cabinet woods in the log enter chiefly through the port of New York, while cabinet wood lumber comes through the Florida, San Francisco, and Philadelphia customs districts.

Shingles from Canada form an important feature of our imports.<sup>1</sup> The volume of shingles fluctuated more or less in unison with imports of sawed material until 1913. Following the removal of the duty on shingles, in that year, the imports grew at a rapid rate, the volume in 1920 being 383 per cent greater than in 1913. These shingles were largely the product of mills in British Columbia although some white cedar shingles also were produced in the eastern provinces and sold in this country. Shingle imports enter this country through the customs districts of Dakota, Washington, Vermont, Maine and New Hampshire, St. Lawrence, and Duluth and Superior.

Cabinet woods, chiefly from Central and South America, Cuba, Mexico and the West Coast of Africa have been imported into the United States for many years. A large part of the cabinet wood imports are mahogany for furniture and for various industrial uses, and Spanish cedar for cigar box manufacture. Some Japanese oak has been imported in recent years through the San Francisco and Puget Sound ports, and used as a substitute for American oak on the Pacific Coast for flooring, furniture manufacture, and interior trim. The high freight rates from the oak-producing regions of the Mississippi valley enabled the Japanese product to become such a serious competitor of American oak that a committee was appointed by the National Hardwood Lumber Association in 1916 to see what could be done to protect the markets for the home products. No action was taken, however, since imports had practically ceased by 1917 owing to lack of tonnage. Japanese oak again appeared in the West Coast markets in 1920 and promises to be an important competitor in the future.

## LUMBER TARIFF

### Early Tariff Acts.

The lumber industry, during the early history of this country, was not concerned seriously with the question of a tariff on lumber since the imports of lumber were negligible. Nevertheless the first tariff act

<sup>1</sup> See Fig. 156.

passed by Congress which became effective on July 4, 1789, contained a clause which placed a 5 per cent ad valorem duty on logs and other lumber products. This remained in effect until the passage of another Act on May 2, 1792, which placed "unmanufactured wood" on the free list.<sup>1</sup>

The early tariff duties on lumber were for revenue, chiefly, and not for the protection of the industry. An act effective July 1, 1794, placed an ad valorem duty "on cabinet wares, and all manufactures of wood, or of which wood is the chief material of value," but left unmanufactured wood on the free list.

An act effective July 1, 1812, placed a duty of 30 per cent ad valorem on "all manufactures of wood or of which wood is the material of chief value." This duty remained in effect until the passage of an Act effective March 3, 1833, which provided specifically, for the first time, for a tariff on "boards, planks" of 25 per cent. This Act as amended, became effective December 31, 1833, and provided for the abolition of the excess above 20 per cent ad valorem.

An Act of August 30, 1842, placed a 30 per cent tax on boards, planks, staves, and scantling, wrought; and on hewed and sawed timber, wrought; a 20 per cent tax on rough boards, planks, staves, and scantling and on rough sawed timbers; and a 15 per cent tax on rosewood, satinwood, mahogany, and cedar wood. Unmanufactured woods, not otherwise specified, remained on the free list.

An Act effective on December 1, 1846, repealed all previous duties, and levied a 30 per cent ad valorem tax on unmanufactured wood, and a 20 per cent tax on boards, planks, staves, laths, scantlings, and hewed and sawed timbers. This Act also placed a 30 per cent duty on logs which had been admitted free since 1792.

In 1855 the first reciprocity treaty with Canada, which dealt specifically with lumber, went into force and remained in effect until March, 1866, when it was abrogated by the United States. The purpose of this treaty was to secure free exchange of natural products, and led to an increase in the sawed lumber trade. It is interesting to note that in discussions held at the time this treaty was under consideration, the policy of the United States with reference to the manner of its disposal of public forest lands was severely criticised by the Canadians who, then as now, advocated the retention of forests in Government hands and the sale of stumpage, only, under license. The effect of the treaty was to place timber and lumber of all kinds, imported from Canada, on the free list from March 15, 1855, to March 17, 1866.

In 1857 the general tariff on lumber as applied to all countries

<sup>1</sup> In the History of the Lumber Industry of America, by J. E. Defebaugh, American Lumberman, 1906, Vol. 1, it is stated that under this Act, rough lumber was probably classed as "unmanufactured wood."

except Canada, was reduced to 15 per cent and on unmanufactured wood to 24 per cent. In 1861 the lumber tariff was increased to 20 per cent and that on unmanufactured wood was reduced to 20 per cent. A change was again made in 1870 when logs were restored to the free list, and the 20 per cent tax on lumber retained.

It was about this time that the lumber industry began to feel the effect of Canadian competition and took an active interest in the tariff question. The tariff law, effective August 1, 1872, was the first to make a specific schedule for lumber, and to provide for an increased tariff on lumber which had been planed or finished, the excess being 50 cents per thousand board feet for each side surfaced, and 50 cents additional when the product was tongued and grooved. A duty of \$1 per thousand board feet was levied on rough sawed boards, planks, deals, and other lumber of hemlock, whitewood, sycamore, and basswood, and \$2 per thousand board feet on all other kinds of sawed lumber. Shingles carried a duty of 35 cents and laths of 15 cents per thousand pieces, while logs remained on the free list.

#### **The Morrill Tariff Act.**

This Act, effective July 1, 1883, made no change in the duties on rough and planed lumber and on logs.

The tariff on lumber imports into the United States led to the levy, by Canada, of an export duty of \$2 per thousand feet, log scale, on logs. This was a severe blow to American manufacturers, many of whom, especially in the Saginaw Valley of Michigan, had invested in Canadian timber and brought the logs to the United States for manufacture. The log export duty of \$2 made this unprofitable and the lumber interests in this country who were directly concerned were confronted with a situation which promised a serious financial loss. Under these conditions there was little or no profit in manufacturing lumber in this country from Canadian logs, and on the other hand the establishment of plants in Canada for lumber manufacture would necessitate the payment of a duty on lumber shipped across the border.

#### **McKinley Tariff Act.**

In 1890 there arose a demand for an adjustment of the lumber tariff relations between the two countries which would correct the unfavorable situation. This was attempted through the so-called McKinley Tariff Act, effective October 6, 1890. There was an implicit understanding between the authorities in Canada and the United States that if the latter country reduced the duty on lumber to \$1 per thousand board feet, the Canadian Government would abolish the export duty on

logs. This idea was embodied in the McKinley Bill, which, however, contained a retaliatory clause providing "that in case any foreign country shall impose an export duty upon pine, spruce, elm, or other logs, . . . exported to the United States from such country, then the duty upon the sawed lumber herein provided for, when imported from such country, shall remain the same as fixed by the law in force prior to the passage of this Act."

The removal of the Canadian export duty led to a rapid increase in the movement of logs into this country, the receipts at Michigan mills, which received the major part of Canadian log imports, increasing from 80,000,000 feet, log scale, in 1891 to 301,000,000 feet in 1894. The effect of this reciprocity arrangement is shown by an increase in the imports of boards, planks, deals, and other sawed products during 1891 and 1893. Trade in 1894, however, fell to a level about equal to that in 1880, due both to an anticipated change in the tariff law which would place lumber on the free list, and to the business depression of that year which greatly reduced lumber sales.

#### **Wilson Tariff Act.**

On August 28, 1894, the Wilson Tariff Act became effective, which provided virtually for free trade in all lumber products. A marked revival in trade occurred during the period from 1895 to 1897, inclusive, the imports of boards, planks, deals, and other sawed products for the latter year being greater than during any previous one and reaching a level not again attained until 1905.

Numerous American firms transferred their manufacturing operations to Ontario, because of the high cost of log towing, since they could ship their product into this country free of duty. The heavy competition which arose between the lower grades of Canadian lumber and similar grades produced in this country, especially in the southern yellow pine region, led to a demand for the restoration of a duty on lumber, as soon as the Republican party had won in the national election of 1896.

#### **Dingley Tariff Act.**

This Act, passed in 1897, again placed lumber on the dutiable list, sawed boards, planks, deals, and other lumber of whitewood, sycamore, and basswood paying a duty of \$1 and other species a duty of \$2 per thousand board feet, and shingles 30 cents and laths 25 cents per 1000 pieces. Logs remained on the free list. For the first time, hemlock was taken out of the class with whitewood, sycamore, and basswood and placed in the group with white pine. The provisions with refer-



ence to surfaced and tongued-and-grooved lumber which were embodied in the McKinley Act were restored. The Dingley Act sought to restrain Canada from reimposing an export duty on logs, by means of a retaliatory clause, similar to that embodied in the McKinley Tariff Act. This clause provided that any export duty so levied should be added to the regular tariff on products originating in that country. Elimination of the lower grades produced in Canada from competition with home products was one of the objects sought by the lumber industry in their effort to restore a tariff on lumber.

The Ontario Government met the situation by issuing a decree prohibiting the export of any and all logs cut on Crown lands after April 1, 1898, the date of expiration of annual licenses to cut timber from such lands. The matter was carried by American limit holders to the highest courts of Canada and later to those of England in which courts the action of the Ontario Government was sustained.

Quebec issued a similar decree in 1910; New Brunswick forbade the exportation of pulpwood from Crown lands during the same year, and the Dominion of Canada, controlling the Crown lands in Manitoba, Saskatchewan, Alberta, and British Columbia also made compulsory the manufacture of logs within the Dominion. The embargo on log shipments from Crown lands in British Columbia has been raised in one or two instances in order to enable loggers to market logs that were deteriorating in the water through teredo attacks, but as soon as the emergency had passed the sale of logs to buyers in the United States was stopped.

Lumber imports during the fiscal year 1897-1898 were 60 per cent below those of the previous year, due to the necessary readjustment which followed the reimposition of a duty on lumber. However, the volume of the import lumber trade, from 1898 until 1909, showed an average annual increase of more than 13 per cent, and the volume of shingle imports increased in about the same ratio.

### **Payne-Aldrich Tariff Act.**

Agitation for a revision of the tariff on forest products was renewed in 1909, the lumber industry in general being opposed to any reduction in the duty on lumber. The Payne-Aldrich tariff bill passed in July, 1909, however, reduced the tariff on whitewood, sycamore, and basswood to 50 cents and that on other species to \$1.25 per thousand board feet. The duty on shingles was raised to 50 cents and that on laths lowered to 20 cents per 1000 pieces. This tariff Act contained a "maximum-and-minimum" clause which provided that "from and after the thirty-first day of March, 1910, there shall be levied, collected and paid

on all articles when imported from any foreign country into the United States, or into any of its possessions (except the Philippine Islands and the islands of Guam and Tutuila), the rates of duty prescribed by the schedules and paragraphs of the dutiable list of Section 1 of this Act, and in addition thereto twenty-five per centum ad valorem, which rates shall constitute the maximum tariff of the United States: Provided that whenever after the thirty-first day of March, 1910, and so long thereafter as the President shall be satisfied, in view of the character of the concessions granted by the minimum tariff of the United States that the government of any foreign country imposes no terms or restrictions, either in the way of tariff rates or provisions, trade or other regulations, charges, exactions, or in any other manner, directly or indirectly, upon the importation into or the sale in such foreign country of any agricultural, manufactured, or other product of the United States, which unduly discriminate against the United States of the products thereof, and that such foreign country pays no export bounty or imposes no export duty or prohibition upon the exportation of any article to the United States which unduly discriminates against the United States or the products thereof and that such foreign country accords to the agricultural, manufactured or other products of the United States treatment which is reciprocal and equivalent thereupon, and thereafter, upon proclamation to this effect by the President of the United States all articles when imported into the United States or any of its possessions (except the Philippine Islands and the Islands of Guam and Tutuila) from such foreign country shall . . . be admitted under the terms of the minimum tariff of the United States, as prescribed by Section 1 of this Act."

In order to assist in the administration of the maximum-and-minimum clause, the Payne-Aldrich Tariff Act provided for the appointment of a Tariff Board to study the tariff problems and to advise the President with reference to the maximum-and-minimum clause and to assist the Government in the administration of the Tariff Act.

The maximum-and-minimum clause was aimed chiefly at Canada, which at the time of the passage of this Act had in force three forms of tariff duty, namely, one applying to imports from the "Mother Country," another called an intermediate tariff applied to "favored nations," and the third a maximum tariff which applied to all imports from the United States.

Great latitude was left to the President in applying the maximum clause and in an early message to Congress his position with reference to the exercise of this power was clearly stated in the following words: "No one is seeking a tariff war or a condition in which the spirit of retaliation shall be aroused." This was brought forth because of the

fear expressed by some that the application of the maximum clause would lead to retaliation on the part of Canada, and by so doing eliminate all trade between the two countries. No action was taken on the matter, pending a study of the situation by the newly created Tariff Board.

### **Reciprocity with Canada.**

On January 26, 1911, the President sent a special message to Congress with reference to the desirability and necessity of establishing closer trade relations with Canada, laying special stress upon forest products, especially those concerned with the paper industry. This followed a study of the pulp and news-print paper industry by the Tariff Board.<sup>1</sup>

A reciprocity bill with Canada which was favorably reported in the House of Representatives early in February, 1911, and which was adopted by a large majority vote, made provision for admitting to both countries, free from import duty, the following products: timbers hewed, sided or squared otherwise than by sawing; sawed boards, planks, deals, and other lumber not further manufactured than by sawing; paving posts; railroad ties; telephone, trolley, electric light, and telegraph poles of cedar or other woods; wooden staves not further manufactured than listed or jointed; stave bolts; pickets; and palings. Shingles and laths were to pay identical duties in both countries.

Sawed boards, planks, deals, and other lumber, planed or finished on one side were to pay a duty of 50 cents per thousand board feet; planed or finished on one side and tongued-and-grooved, 75 cents; planed or finished on three sides \$1.12; and planed or finished on four sides, \$1.50.

This bill failed to come to a vote in the Senate and a special session of Congress was called in April to consider the Reciprocity Bill, which had met with opposition both in the United States and in Canada. A reciprocity bill was again introduced on April 12 and passed by the House Committee on Finance of the Senate which, on June 13, reported the bill with the Root amendment to the Senate.<sup>2</sup> The bill, as transmitted by the House, was passed without amendment on July 22 and soon after was signed by the President.

The question of a reciprocity treaty with Canada was now in the hands of the latter country. After a spirited political campaign, in

<sup>1</sup> Pulp and News-Print Paper Industry, Message from the President of the United States transmitting a Report by the Tariff Board relative to Pulp and News-Print Paper Industry. Senate Document No. 31, 62d Congress, 1st Session, Washington, 1911.

<sup>2</sup> This amendment provided that wood-pulp, paper, and board should not be admitted free until all restrictions in all provinces of the Dominion had been removed.

which the Liberal party supported the reciprocity idea, the question came to a vote and the Liberals were retired from power at an election held in September, 1911, and all hopes of a reciprocal tariff agreement were abandoned.

### **Underwood-Simmons Tariff Act.**

With the coming into power of the Democratic party in this country in 1912, the agitation for a reduction in the tariff duties was again revived and the Underwood-Simmons Tariff Bill, which placed lumber on the free list, became a law on October 3, 1913, on which date it was signed by the President. This Act placed timbers, boards, planks, and deals, both rough, and dressed and matched; logs and round unmanufactured timber; pulp woods; laths; shingles; and many other products on the free list.<sup>1</sup>

The effect of the removal of the import duty on lumber was to increase to a small extent, the imports of boards, planks, deals, and other sawed products, and to increase enormously the importation of shingles, the volume of which rose from more than 500 million pieces, during the fiscal year of 1913, to more than 2152 million pieces in 1920.

Since the return to power of the Republican party through the 1920 election, there has been agitation for the reimposition of a duty on lumber, but no definite steps have been taken to revise the tariff laws of the country.

Protection rather than revenue has been the ruling motive for many years in formulating the tariff legislation in the United States. Tariff laws relating to forest products have been formulated chiefly with reference to trade with Canada, which was the chief competitor of lumber manufacturers in the United States. It was directed against softwoods, chiefly white pine in the early days, and later eastern spruce and Douglas fir, since these are the species which competed with similar products manufactured in the United States.

The duty on hardwoods such as basswood, sycamore, and whitewood had been of little importance since Canada has never exported a large volume of these species to this country. The imports of other hardwoods, almost exclusively cabinet woods and "woods of value," have been so limited and their uses so specialized that the volume has not been affected appreciably by any past tariff provisions. Logs have been on the free list for many years because lumber manufacturers in the United States, especially those operators tributary to Canadian supplies by water routes, have found it advantageous to purchase logs in Canada to be worked up in mills in this country.

<sup>1</sup> A synopsis of Schedule D of the Underwood-Simmons Tariff Bill may be found in the Appendix, pages 517 and 518.

The lumber producers in the United States, outside of those areas adjacent to Canadian supplies, have not been affected by the presence or absence of tariff restrictions imposed on Canadian exports. This is true especially of the southern pine region. Lumber shipments from Canada to the United States have continued for many years without regard to tariff regulations. From 1898 to 1916 there was a gradual increase in shipments even though a \$2 duty was in force from 1897 to 1909, and a \$1.25 duty from 1909 to 1913. During 1914 and 1915, due to war conditions, the imports from Canada decreased, but in 1917 they reached a peak which was again on a line with the average increase from 1898.<sup>1</sup>

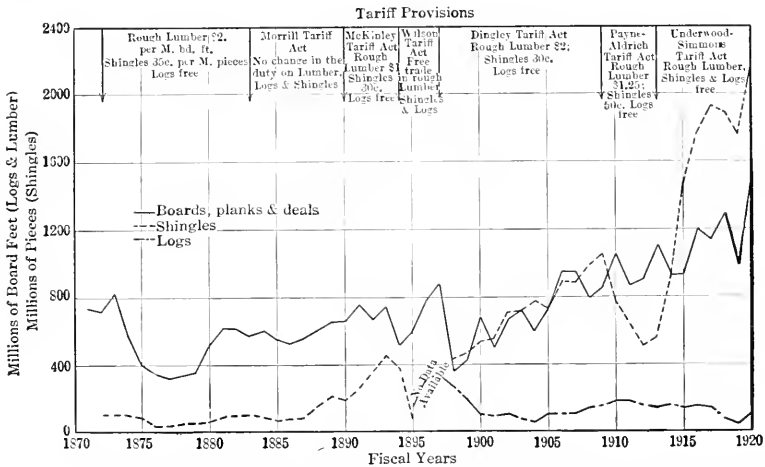

FIG. 156.—The Imports of Logs, Lumber, and Shingles into the United States and the Tariff Regulations in Effect from 1870 to 1920, inclusive.

Free lumber will play a more important part in the economic life of this country in the future than it has in the past. Our population is steadily increasing and our home production declining, and it is very desirable that we supplement our own lumber supplies with those from outside sources. Therefore, every effort should be made to encourage the import of lumber products which are in demand, and, as a means to this end, sawed lumber products and logs should continue to remain on the free list.

<sup>1</sup> Fig. 156 shows, graphically, the imports of sawed lumber, shingles and logs into the United States for the fiscal years 1872 to 1920, inclusive.



# APPENDIX

---

## BIBLIOGRAPHY

### ECONOMIC STUDIES OF THE LUMBER INDUSTRY

- Greeley, W. B.: Some Public and Economic Aspects of the Lumber Industry. U. S. Dept. of Agriculture, Report No. 114, Washington, 1917.
- Mason, D. T.: Timber Ownership and Lumber Production in the Inland Empire. The Western Pine Manufacturers' Association, Portland, Oregon, 1921.
- U. S. Dept. of Labor: Economics of the Construction Industry. Washington, 1919, pp. 90 to 107, inc.

### FOREIGN MARKETS

- Arnold, John R.: Lumbering Industry of the Philippines. Dept. of Commerce, Bureau of Foreign and Domestic Commerce, Special Agents' Series, No. 88, Washington, 1914.
- Brown, Nelson C.: The Lumber Market in Italy and Reconstruction Requirements. Dept. of Commerce, Bureau of Foreign and Domestic Commerce, Special Agents' Series, No. 182, Washington, 1919.
- Brown, Nelson C.: Lumber Markets of Spain and Portugal. Dept. of Commerce, Bureau of Foreign and Domestic Commerce, Special Agents' Series, No. 201, Washington, 1919.
- Federal Trade Commission: Report on Cooperation in American Export Trade. Part 1, Chap. V, Competitive Conditions and Export Cooperation in Particular Industries, Sec. 8, Lumber, pp 310 to 325, Washington, 1916.
- MacMillan, H. R.: Report on the Timber Trade of Australia. Supplement to Weekly Bulletin of the Dept. of Trade and Commerce, Ottawa, Canada, 1917.
- MacMillan, H. R.: Lumber Trade of Holland. Dept. of Trade and Commerce, Weekly Bulletin, Nov. 15, 1915, Ottawa, Canada.
- MacMillan, H. R.: Report on the Timber Import Trade of Australia. Supp. to Weekly Bulletin, Dept. of Trade and Commerce, Ottawa, Canada, 1917.
- Oxholm, A. H.: Forest Resources, Lumber Industry, and Lumber Export Trade of Finland. Dept. of Commerce, Special Agents' Series, No. 207, Washington, 1921.
- Oxholm, A. H.: Swedish Forests, Lumber Industry, and Lumber Export Trade. Dept. of Commerce, Bureau of Foreign and Domestic Commerce, Special Agents' Series, No. 195, Washington, 1921.
- Pratt, Edward Ewing: The Export Lumber Trade of the United States. Dept. of Commerce, Bureau of Foreign and Domestic Commerce, Misc. Series, No. 67, Washington, 1918.

- Rosenbluth, Robert: Forests and Timber Trade of the Chinese Empire. Forestry Quarterly, Vol. 10, pp. 647 to 672.
- Simmons, Roger E.: Lumber Markets of the East Coast of South America. Dept. of Commerce, Bureau of Foreign and Domestic Commerce, Special Agents' Series, No. 112, Washington, 1916.
- Simmons, Roger E.: Lumber Markets of the West and North Coasts of South America. Dept. of Commerce, Bureau of Foreign and Domestic Commerce, Special Agents' Series, No. 117, Washington, 1916.
- Smith, Franklin H.: Japanese Markets for American Lumber. Dept. of Commerce, Bureau of Foreign and Domestic Commerce, Special Agents' Series, No. 94, Washington, 1915.
- Smith, Franklin H.: Philippine Markets for American Lumber. Dept. of Commerce, Bureau of Foreign and Domestic Commerce, Special Agents' Series, No. 100, Washington, 1915.
- Smith, Franklin H.: China and Indo-China Markets for American Lumber. Dept. of Commerce, Bureau of Foreign and Domestic Commerce, Special Agents' Series, No. 104, Washington, 1915.
- Smith, Franklin H.: Trade in Siam and Indo-China. Dept. of Commerce, Bureau of Foreign and Domestic Commerce, Special Agents' Series, No. 108, Washington, 1915.
- Smith, Franklin H.: Australasian Markets for American Lumber. Dept. of Commerce, Bureau of Foreign and Domestic Commerce, Special Agents' Series, No. 109, Washington, 1915.
- Zon, Raphael: The Forest Resources of the World. U. S. Dept. of Agriculture, Forest Service Bul. 83, Washington, 1910.
- Zon, R.: Lumber Markets of the Mediterranean Region and the Near East. Dept. of Commerce, Bureau of Foreign and Domestic Commerce, Washington, 1917.

### HISTORY OF THE LUMBER INDUSTRY

- Bureau of Industrial and Labor Statistics: Thirteenth Annual Report for the State of Maine, 1899. The Lumber Industry, pp. 64 to 86, incl., Augusta, 1900.
- Craig, R. D.: History of Lumbering in the San Bernadinos. Manuscript Report, Forest Service, U. S. Dept. of Agriculture, 1904.
- Defebaugh, James Elliott: History of the Lumber Industry of America. Vols. 1 and 2, American Lumberman, Chicago, Ill., 1907.
- Folsom, Wm. C. C.: Lumbering in the St. Croix Valley with Biographic Sketches. Minnesota Historical Society Collections, Minneapolis, 1900.
- Fox, William F.: A History of the Lumber Industry in the State of New York. U. S. Dept. of Agriculture, Bureau of Forestry, Bul. 34, Washington, 1902.
- Hobbs, John E.: Beginnings of Lumbering in the New World. Forestry Quarterly, Vol. IV, No. 1, pp. 14 to 23, incl.
- Hotchkiss, Geo. W.: History of the Lumber and Forest Industry of the Northwest. G. W. Hotchkiss and Co., Chicago, Ill., 1898.
- Hotchkiss, Geo. W.: Industrial Chicago. Vol. III, The Manufacturing Interests. Goodspeed Pub. Co., Chicago, Ill., 1894. The first nine chapters treat of the lumber trade of Chicago.
- Walker, John B.: Three Centuries of North Carolina Pine. American Lumberman, Chicago, Ill., May 4, 18, 25, June 1, 8, 22, July 6, 13, 20, 27, Aug. 3, 10, 17, 31, Sept. 7, 14, 21, Oct. 5, 19, and 26, 1907.



## LABOR

- State Safety Board of Washington: Safety Regulations for Washington Sawmills. The Timberman, Portland, Oregon. May, 1920, pp. 41 to 43.
- U. S. Dept. of Labor, Bureau of Labor Statistics: Industrial Survey in Selected Industries in the United States, 1919. Preliminary Report, Prepared under the Supervision of Allan H. Willett. U. S. Dept. of Labor, Washington, 1920, pp. 348 to 363.
- U. S. Dept. of Labor, Bureau of Labor Statistics: Wages and Hours of Labor in the Lumber, Millwork, and Furniture Industries, 1915. Bul. No. 225, Washington, Feb., 1918.
- U. S. Dept. of Labor, Bureau of Labor Statistics: Workmen's Compensation Laws of the United States and Foreign Countries, Bul. No. 126, Washington, Dec. 23, 1913.
- U. S. Dept. of Labor: Descriptions of Occupations, Logging Camps and Sawmills. Washington, 1918.
- U. S. Dept. of Labor, Bureau of Labor Statistics: Industrial Survey in Selected Industries in the United States, 1919. Washington, May, 1920.
- Van Schaak, David: Woodworking Safeguards for the Prevention of Accidents in Lumbering and Woodworking Industries. Aetna Life Insurance Co., Hartford, Conn., 1911.

## LUMBER GRADES AND INSPECTION

- Betts, H. S.: How Lumber is Graded. U. S. Dept. of Agriculture, Dept. Circular 64, Washington, March, 1920.
- Curtis, Vanderveer: Lumber Grading in the Pacific Northwest. Quarterly Journal of Economics, Vol. XXII, No. 3, May, 1912, Pub. by Harvard University, Cambridge, Mass.
- Lumber Inspection Rules: The Lumber Inspection Rules. 4th Edition, 1921. For sale by American Lumberman, Chicago, Ill.
- White Pine Bureau: Classified Recommended Uses for White Pine in House Construction and White Pine Standard Grading Rules. St. Paul, Minn., 1917.

## LUMBER HANDLING

- Lumber World Review: Handling Lumber in and out of a Yard by Locomotive Crane. Lumber World Review, Chicago, Ill., July 10, 1921, pp. 35 and 36.
- Williams, J. S.: An Analysis of the Various Systems for Handling Lumber at the Mill. West Coast Lumberman, Seattle, Wash., Jan. 1, 1915, pp. 42 to 48.

## LUMBER INVENTORY SYSTEMS

- Gilbert, P. E.: The Gilbert Inventory System. American Lumberman, Chicago, Ill., June 19, 1915, pp. 32 and 33. Southern Lumberman, Nashville, Tenn., Sept. 19, 1914, pp. 38 and 39.
- Miller, Malcolm: Keeping an Accurate Inventory of Yard Stock. American Lumberman, Chicago, Ill., April 28, 1917, pp. 30 and 39.

## LUMBER MANUFACTURE

- Berry, Swift: *Lumbering in the Sugar and Yellow Pine Region of California*. U. S. Dept. of Agriculture, Bul. No. 40, Washington, 1917, pp. 65 to 96.
- Berry, Swift S.: *A Study of the Grades of Lumber Produced from California Pine, Fir, and Cedar*. The Timberman, Portland, Ore., March, 1918, pp. 36 and 37, and April, 1918, pp. 39 and 40.
- Blackman, W. J.: *Sawmill Work and Practice*. William Rider and Son, Ltd., London.
- Grondal, B. L.: *Sawmill Practice in the Pacific Northwest*. West Coast Lumberman, Seattle, Wash., May 1, 1920, pp. 118, 120, 122, 124, 125, 127, and 234 to 238.
- Larsen, L. T. and Woodbury, T. D.: *Sugar Pine*. U. S. Dept. of Agriculture, Bul. No. 426, Dec., 1916, pp. 13 to 22.
- Mattoon, W. R.: *The Southern Cypress*. U. S. Dept. of Agriculture, Bul. No. 272, pp. 14 to 18.
- Munger, T. T.: *Western Yellow Pine in Oregon*. U. S. Dept. of Agriculture, Bul. 418, Washington, 1917, pp. 34 and 35.
- Murray, F. F.: *Log Washing*: Lumber, St. Louis, Mo., Dec. 13, 1920.
- Oakleaf, H. B.: *Lumber Manufacture in the Douglas Fir Region*. Lumber, St. Louis, Mo., Feb. 16, 23; March 1, 8, 15, 22, 29; April 5, 12, 19; May 3, 10, 17, 24, 31; June 14, 21, 28; July 5, 12, 19, 26; Aug. 2, 16, 23, 30.
- Prescott, C. Clint.: *Evolution of Modern Band Mills for Sawing Logs*. The Prescott Co., Menominee, Mich., 1910.
- White, David G.: *The Manufacture and Seasoning of Oak*. *Hardwood Record*, Chicago, Ill., Aug. 25, 1921, pp. 18 to 20.

## LUMBER MERCHANDISING

- Butler, O. M.: *The Distribution of Softwood Lumber in the Middle West*. Wholesale Distribution Studies of the Lumber Industry, Part VIII, U. S. Dept. of Agriculture, Report No. 115, Washington, 1917.
- Butler, O. M.: *The Distribution of Softwood Lumber in the Middle West*. Retail Distribution. Studies of the Lumber Industry, Part IX. U. S. Dept. of Agriculture, Report No. 116, Washington, 1918.
- Gries, John M.: *Line Yards (The Chain Store in the Lumber Trade)*. American Lumberman, Chicago, Ill., March 15, 22, 29, 1919.
- Hill, Charles: *The Merchandising of Lumber*. School of Forestry, Yale University, Lumber Industry Series II, New Haven, Conn., 1922.
- Mattoon, W. L. and Barrows, W. B.: *Measuring and Marketing Woodlot Products*. U. S. Dept. of Agriculture, Farmer's Bulletin 715, Washington, 1916.
- Mueller, Ben C.: *The Mail Order Lumber Business*. American Lumberman, Chicago, Ill., Dec. 2, 16, 30, 1916; Jan. 13 and 27, 1917.
- Peterson, F. H.: *Investigation of the Trade Practices and Profits Involved in the Manufacture and Sale of Building Material*. State of Minnesota, State Department of Agriculture, Bul. No. 9, St. Paul, Minnesota, July 20, 1920.
- U. S. Dept. of Commerce and Labor, Bureau of Corporations: *The Lumber Industry, Part IV, Conditions in Production and Wholesale Distribution Including Wholesale Prices*, Washington, 1914.

## LUMBER PRICES

- Bryant, R. C.: Prices of Lumber. War Industries Board, Price Bul. No. 43, Washington, 1919.
- Bryant, R. C.: Lumber Prices. The Annals of the American Academy of Political and Social Science, Philadelphia, Pa., May, 1920.
- Butler, O. M.: Softwood Lumber Prices in the Middle West. American Lumberman, Chicago, Ill., Oct. 2, 1920.
- Compton, Wilson: The Organization of the Lumber Industry. American Lumberman, Chicago, Ill., 1916.
- Compton, Wilson: Price Problems in the Lumber Industry. American Economic Review, Vol. VII, No. 3, Sept., 1918.
- Goodman, Robert B.: The Price of Lumber. Yale University, School of Forestry, Lumber Industry Series I, New Haven, Conn., 1920. .
- Stephens, George A.: Determinants of Lumber Prices. American Economic Review, Vol. VII, No. 2, June, 1917.
- U. S. Dept. of Agriculture, Forest Service: Wholesale Lumber Prices, 1886-1908, Washington, 1909.
- U. S. Dept. of Labor, Bureau of Labor Statistics: Wholesale Prices, 1890 to 1916. Bul. No. 226, Washington, 1917.

## LUMBER TRANSPORTATION

- Interstate Commerce Commission: Digest of Answers to Interrogatories Propounded by the Interstate Commerce Commission in Docket No. 8131, in the Matter of Rates and Classification of Lumber and Lumber Products, Washington, 1916.
- Interstate Commerce Commission: No. 8131. In the Matter of Rates on and Classification of Lumber and Lumber Products. Washington, 1919, pp. 598 to 670.

## MILL SCALE STUDIES

- Berry, Swift S.: A Study of the Grades of Lumber Produced from California Pine, Fir and Cedar. The Timberman, Portland, Ore., March, 1918, pp. 36 and 37, and April, 1918, pp. 39 and 40.
- White, David G.: A Mill Scale Study of Maple. Hardwood Record, Chicago, Ill., Feb. 10, 1917, pp. 41a to 41f, incl.
- White, David G.: The Manufacture and Seasoning of Oak. Hardwood Record, Aug. 25, 1921, pp. 18 to 20, incl.

## SAWMILL MACHINERY

- Bale, M. Powis: Handbook of Saw-mill and Wood Converting Machinery. 3d Edition. William Rider and Son, Ltd., London, 1910.
- Bale, M. Powis: Sawmills—Their Arrangement and Management and the Economical Conversion of Timber. 5th Edition, Crosby Lockwood & Son, London, 1919.
- Beach, Brewster S.: Application of Electricity in Sawmills and Logging Operations. Southern Lumberman, Nashville, Tenn., Dec. 20, 1919, pp. 157 and 158.

- Hall, Allan E.: Electrically Driven Sawmills. *The Southern Lumberman*, Nashville, Tenn., Dec. 18, 1920, pp. 202 to 204.
- Leibe, R. C.: A Practical Portable Band Sawmill Plan. *American Lumberman*, Chicago, Ill., April 16, 1921, pp. 66 and 67.
- Murray, F. F.: Electric Networks for Sawmill Carriage with Particular Reference to Power Take-off Devices. *Lumber*, St. Louis, Mo., April 8, 1921, pp. 17 to 20, incl.
- Murray, F. F.: Wood-Burning Boiler Furnaces. *Lumber*, St. Louis, Mo., April 22, 1921, pp. 15 to 18, incl.
- Murray, F. F.: Belt Conveying in a Sawmill Plant. *Lumber*, St. Louis, Mo., Aug. 26, 1921, pp. 17 to 20.
- Murray, F. F.: Power Chain Drives in Sawmill and Planer. *Lumber*, St. Louis, Mo., Aug. 12, 1921, pp. 15 to 18 and 51.
- Prescott Co., The: The Evolution of Band Saw Mills for Sawing Logs. Menominee, Mich., 1910.
- Ransom, Allen E.: Specific Facts about Electricity: Its Application to the Lumber Industry. *The Timberman*, Portland, Ore., Aug., 1917, p. 39.
- Seerey, Daniel E.: Small Sawmills. U. S. Dept. of Agriculture, Bul. No. 718, Washington, 1918.
- Whitney, E. F.: Electricity in the Lumber Industry. Proceedings of the American Institute of Electrical Engineers, Vol. XXXIII, No. 2, Dec., 1914, pp. 1823 to 1862.

#### SAWS

- Atkins & Co., E. C.: Saws in the Filing Room. Indianapolis, Ind.
- Disston & Sons, Henry: The Saw in History. Philadelphia, Pa., 1915.
- Grimshaw, Robert: Saw Filing and Management of Saws. The Norman W. Henley Publishing Co., New York, 1912.
- Machinery Company of America: Saw and Knife Fitting Manual. 4th Edition, Big Rapids, Mich., 1920.

#### SEASONING LUMBER

- Betts, Harold S.: The Seasoning of Wood. U. S. Dept. of Agriculture, Bul. No. 552, Washington, July 9, 1917.
- Betts, Harold S.: Timber: Its Strength, Seasoning and Grading. McGraw-Hill Book Co., Inc., New York, 1919.
- Brewster, D. R.: Schedules for Drying Lumber. *Hardwood Record*, Chicago, Ill., July 10, 1920, pp. 19 to 21; Aug. 10, 1920, pp. 20 to 23.
- Helphenstine, Jr., R. K.: Piling Lumber to Prevent Deterioration. *Hardwood Record*, Chicago, Ill., July 25, and Aug. 10, 1920.
- Humphrey, C. J.: Timber Storage Conditions in the Eastern and Southern States with Reference to Decay Problems. U. S. Dept. of Agriculture, Bul. No. 510, Washington, 1917.
- Inurie, James E.: How to Measure the Conditions in Seasoned Lumber. *American Lumberman*, Chicago, Ill., March 10, 1917, pp. 38 and 39.
- Kempfer, Wm. H.: The Air Seasoning of Timber. American Railway Engineering Association, Bul. 161, Nov., 1913.

- Koehler, Arthur: Relation of Moisture Content and Drying Rate of Wood to Humidity of Atmosphere. American Lumberman, Chicago, Ill., July 12, 1919, pp. 54 and 55.
- Oakleaf, H. B.: Kiln Drying Douglas Fir and other Northwestern Woods. The Pacific Lumber Trade Journal, Seattle, Wash., March, 1913.
- Pratt, Merritt B.: The Deterioration of Lumber. College of Agriculture, Agricultural Experiment Station, Berkeley, Cal., Bul. No. 252, May, 1915, pp. 300 to 320.
- Teesdale, L. V.: Manual of Design and Installation of Forest Service Water Spray Dry Kiln. U. S. Dept. of Agriculture, Bul. No. 894, Washington, Oct. 18, 1920.
- Tiemann, H. D.: Kiln Drying Lumber. J. B. Lippincott Co., Philadelphia, Pa., 1917.
- Tiemann, H. D.: Kiln Drying Systems Compared. Hardwood Record, Chicago, Ill., Sept. 10, 1920, pp. 15 to 23.
- Von Schrenk, Hermann: Seasoning of Timber. U. S. Dept. of Agriculture, Bureau of Forestry, Bul. No. 41, Washington, 1903.
- Von Schrenk, Hermann: The "Bluing" and the "Red Rot" of the Western Yellow Pine, with Special Reference to the Black Hills Forest Reserve. U. S. Dept. of Agriculture, Bureau of Plant Industry, Bul. No. 36, Washington, 1903.
- Weiss, Howard F., and Barnum, Charles T.: The Prevention of Sap-stain in Lumber. U. S. Dept. of Agriculture, Forest Service Cir. 192, Washington, 1911.

## STATISTICS

- California Sugar and White Pine Manufacturers' Association. Summary of Production, Shipments, Inventory and Orders (Monthly), San Francisco, Cal.
- Defebaugh, J. E.: History of the Lumber Industry in America. Vol. I, American Lumberman, Chicago, Ill., 1906.
- Kellogg, R. S.: Exports and Imports of Forest Products: 1906. U. S. Dept. of Agriculture, Forest Service Cir. 110, Washington, 1907.
- National Lumber Manufacturers' Association. National Lumber Trade Barometer (Weekly), Washington, D. C.
- Nellis, J. C.: Lumber Used in the Manufacture of Wooden Products. U. S. Dept. of Agriculture, Bul. No. 605, Washington, Feb. 27, 1918.
- North Carolina Pine Association. Weekly Report of Orders, Shipments, and Production; Norfolk, Va.
- North Carolina Pine Association: Bulletin (Monthly). This contains monthly Summary of Stocks and Orders, and Cut and Shipments; Norfolk, Va.
- Smith, F. H. and Pierson, A. H.: Production of Lumber, Lath, and Shingles in 1918. U. S. Dept. of Agriculture, Bul. No. 845. Also contains annual production for the years 1909 to 1918, incl., Washington, April 13, 1920.
- Southern Pine Association: Weekly Trade Barometer. New Orleans, La.
- Southern Pine Association: Cost Statement (Monthly). New Orleans, La.
- Southern Pine Association: Monthly Trade Barometer. New Orleans, La.
- Southern Pine Association: Report of Sales (Tri-monthly). New Orleans, La.
- U. S. Dept. of Agriculture, Bureau of Statistics: Foreign Trade of the United States in Forest Products, 1851 to 1908. Bul. 51, Washington, 1909.
- U. S. Dept. of Agriculture, Bureau of Statistics: Imports of Farm and Forest Products: 1909 to 1911. Bul. 95, Washington, 1912.
- U. S. Dept. of Commerce and Labor, Bureau of Census: Production of Lumber, Lath, and Shingles, by States and Species, 1906, 1905, and 1904. Washington, 1907.

- U. S. Dept. of Commerce and Labor, Bureau of Census: Forest Products of the United States, 1907. Forest Products No. 10, Washington, 1909.
- U. S. Dept. of Commerce and Labor, Bureau of Census: Forest Products of the United States, 1908. Washington, 1909.
- U. S. Dept. of Commerce and Labor, Bureau of the Census: Forest Products of the United States, 1909. Washington, 1911.
- U. S. Dept. of Commerce and Labor, Bureau of the Census: Forest Products: 1919 Lumber, Lath, and Shingles. Washington, 1922.
- Western Pine Manufacturers' Association: Weekly Report of Order File and Cut. Portland, Ore.
- West Coast Lumbermen's Association. Weekly Report of Order File and Shipments. Seattle, Wash.

#### WASTE IN LUMBER MANUFACTURE

- Cline, McGarvey: Waste in Use of Timber. Report of the National Conservation Commission, Vol. II, Senate Document No. 676, 60th Congress, 2d Session, Washington, 1909, pp. 568 to 580.
- Gulick, J.: Commercial Hog Fuel and How to Burn It. The Timberman, Portland, Ore., April, 1921, pp. 42 and 43.
- Margolin, Louis: Waste in Milling. Report of the National Conservation Commission, Vol. II, Senate Document No. 676, 60th Congress, 2d Session, Washington, 1909, pp. 547 to 567.
- Thelen, Rolf: The Cost of Burning Sawmill Refuse. Southern Lumberman, Nashville, Tenn., April 22, 1916, p. 27.
- Upson, A. T.: Waste in Logging and Milling in Colorado. University of Nebraska Forest Club Annual, Lincoln, Vol. 2, 1910, pp. 67 to 77.
- Wilson, George S.: Douglas Fir Sawmill Waste Can be Used in a Well-built Gas Producer. The Timberman, Portland, Ore., March 15, 1917, p. 66.

#### WOOD-USING INDUSTRIES

- Armstrong, A. K.: Wood-using Industries of California. Cal. State Board of Forestry, Bul. No. 3, Sacramento, 1912.
- Besley, F. W.: The Wood-using Industries of Maryland. Maryland State Board of Forestry, Baltimore, 1919.
- Dunning, C. W.: Wood-using Industries of Idaho. Pacific Lumber Trade Journal, Seattle, Wash., July, 1912.
- Dunning, C. W.: Wood-using Industries of Ohio. Ohio Agricultural Experiment Station, Wooster, 1912.
- Gould, C. W.: The Wood-using Industries of Mississippi. Lumber Trade Journal, New Orleans, La., March 15, 1912.
- Gould, C. W.: The Wood-using Industries of Tennessee. Southern Lumberman, Nashville, Tenn., May 25, 1912.
- Harris, J. T.: The Wood-using Industries of Alabama. Lumber Trade Journal, New Orleans, La., May 1, 1912.
- Harris, J. T.: Wood-using Industries and National Forests of Arkansas. U. S. Dept. of Agriculture, Forest Service, Bul. 106, Washington, 1912.
- Hatch, C. F.: The Wood-using Industries of Missouri. St. Louis Lumberman, St. Louis, Mo., March 15, 1912.
- Knapp, J. B.: Montana's Secondary Wood-using Industries. The Timberman, Portland, Ore., Nov., 1912.

- Lewis, R. G.: Wood-using Industries of the Maritime Provinces. Dept. of the Interior, Forestry Branch, Ottawa, Canada, 1914.
- Lewis, R. G.: Wood-using Industries of the Prairie Provinces. Dept. of the Interior, Forestry Branch, Bul. No. 50, Ottawa, Canada, 1915.
- Lewis, R. G.: Wood-using Industries of Ontario. Dept. of Interior, Forestry Branch, Bul. No. 36, Ottawa, Canada, 1913.
- Lewis, R. G.: Wood-using Industries of Quebec. Dept. of Interior, Forestry Branch, Bul. No. 63, Ottawa, Canada, 1918.
- MacMillan, H. R.: Wood-using Industries, 1910 (Canada). Dept. of the Interior, Forestry Branch, Ottawa, Canada, 1912.
- Maxwell, H.: Wood-using Industries of Florida. Quarterly Bull., Florida, Dept. of Agriculture, July, 1913.
- Maxwell, H.: The Wood-using Industries of Iowa. Iowa Agriculture Experiment Station, Bul. 142, Ames, Iowa, 1913.
- Maxwell, H.: The Wood-using Industries of Louisiana. Lumber Trade Journal, New Orleans, La., Jan. 1, 1912.
- Maxwell, H.: Wood-using Industries of Michigan. Public Land Commission, Lansing, Michigan, 1912.
- Maxwell, H.: Wood-using Industries of Minnesota. Minn. State Forestry Board, St. Paul, 1913.
- Maxwell, H.: The Wood-using Industries of Texas. Lumber Trade Journal, New Orleans, La., 1912.
- Maxwell, H.: The Wood-using Industries of Vermont. Vermont Forestry Pub. No. 11, Rutland, 1913.
- Maxwell, H.: A Study of Massachusetts Wood-using Industries. Boston, 1910.
- Nellis, J. C.: The Wood-using Industries of Indiana. Hardwood Record, Chicago, Ill., March 1, 1916.
- Nellis, J. C.: Wood-using Industries of Maine. Report of the Forest Commission, Augusta, 1912.
- Nellis, J. C.: Wood-using Industries of West Virginia. West Virginia Dept. of Agriculture, Bul. No. 10, Charlestown, 1914.
- Oakleaf, H. B.: The Wood-using Industries of Oregon. Oregon Conservation Association, Portland, 1911.
- Oakleaf, H. B.: Box Manufacture in Washington's Secondary Wood-using Industries. Pacific Lumber Trade Journal, Seattle, Wash., Nov., 1911.
- Pierson, A. H.: Wood-using Industries of Connecticut. Conn. Agricultural Experiment Station, Bul. 174, Hartford, 1913.
- Pierson, A. H.: Wood-using Industries of New Jersey. Report of Forest Park Reservation Commission, Union Hill, N. J., 1914.
- Reynolds, R. V., and Hoyle, R. J.: Wood-using Industries of New York. Tech. Publication No. 14, New York State College of Forestry, Syracuse, 1921.
- Simmons, R. E.: The Wood-using Industries of Illinois. Dept. of Horticulture, University of Illinois, Urbana.
- Simmons, R. E.: A Study of the Wood-using Industries of Kentucky. State Board of Agriculture, Forestry and Immigration, 1910.
- Simmons, R. E.: Wood-using Industries of New Hampshire. New Hampshire Forestry Commission, Concord, 1912.
- Simmons, R. E.: Wood-using Industries of North Carolina. North Carolina Geol. and Econ. Survey, Paper No. 20, Raleigh, 1910.
- Simmons, R. E.: Wood-using Industries of Pennsylvania. Penn. Dept. of Forestry Bul. 9, Harrisburg, 1914.

- Simmons, R. E.: Wood-using Industries of Virginia. American Forestry Association, Washington, 1912.
- Smith, F. H.: A Study of Wisconsin Wood-using Industries. Madison, 1910.
- U. S. Dept. of Agriculture, Forest Service: Wood-using Industries of Georgia. Lumber Trade Journal, New Orleans, La., March 15, 1914.
- Wolfe, S. L.: Wood-using Industries of South Carolina. Dept. of Agriculture, Commerce, and Industries, Columbia, 1913.

#### WOODWORKING MACHINERY

- Bale, M. Powis: Woodworking Machinery, its Rise, Progress and Construction with Hints on the Management of Sawmills and the Economical Conversion of Timber. 4th Edition. Crosby Lockwood & Son, London, 1919.
- Madsen, Lern: Exhauster System in Wood-working Plants. Wood Worker, Indianapolis, Ind., July, Aug., Sept., and Oct., 1921.
- Nichols, H. M.: Exhaust Systems for Woodworking Machines. American Lumberman, Chicago, Ill., Nov. 26, 1921, pp. 46 and 47.
- Ransomes, Stafford: Modern Woodworking Machinery. 3d Edition. William Rider & Son, Ltd., London, 1902.
- Still, F. R.: Removal of Shop Refuse by Fans or Blowers. Wood Craft, Indianapolis, Ind., Aug., 1912, pp. 150 and 151.



## TERMS USED IN LUMBER MANUFACTURE AND DISTRIBUTION

[Letters in parentheses following definitions indicate the forest region in which the terms as defined are used.]

- (Gen.) = General = In all forest regions of the United States.
- (App.) = Appalaehian Forests.
- (L.S.) = Lake State Forests.
- (N.W.) = North Woods.
- (R.M.F.) = Rocky Mountain Forests.
- (Cal.) = California Forests.
- (E.C.) = Eastern Canada Forests.
- (N.F.) = Northern Forests.
- (S.F.) = Southern Forests.
- (P.C.F.) = Pacific Coast Forests.
- (U.K.) = United Kingdom.

**Air-dried lumber.** Lumber which has been seasoned in the open air as contrasted to that seasoned in a dry kiln. (Gen.)

**Arbor, n.** *See* Saw arbor.

**Arkansas dry kiln.** An early form of kiln consisting of an open box from 16 to 20 feet square with a platform about 8 feet above the ground, on which the lumber is piled. The kiln is open at the top. A fire is built under the platform and heat, sparks, and smoke pass up through the lumber, which gradually becomes dry. (S. F.)

**Back, n.** The upper or convex part of a saw tooth. (Gen.)

**Backing board.** In sawing lumber on a head-saw, the last board in the log to which the carriage dogs are attached.

Syn.: dog board (Gen.), back stand (R. M. F.).

**Back stand.** *See* Backing board.

**Band mill.** 1. A sawmill equipped with a band head-saw. (Gen.)

2. A machine on which band saws are mounted. (Gen.)

**Band saw.** An endless, belt-like blade of steel, toothed on one or both edges, which is used to saw lumber. (Gen.)

**Barking saw.** *See* Rock saw.

**Barnboards.** Boards used for barn siding. (L. S.)

**Barrel saw.** *See* Cylinder saw.

**Base, n.** Interior trim which is fastened to the walls of a room at the floor line. (Gen.)

Syn.: base-board.

\* A revised edition of Forest Terminology, Part II. Terms used in the Lumber Industry. Prepared by the author as Chairman of a Committee of the Society of American Foresters

- Base-board.** *See* Base.
- Bastard grain.** *See* Plain-sawed.
- Batch, n.** A raft of lumber composed of a number of units. (S. F.)
- Batt.** *See* Batten.
- Batten, n.** A narrow strip of lumber which is used on buildings to cover cracks in siding or roofing. (Gen.)  
Syn.: batt.
- Bed piece.** One of the skids placed under a pile of lumber. (N. F.)
- Bevel cribbing.** Boards beveled on both edges, which are used as siding for a corn crib. (Gen.)  
Syn.: Corn-cribbing (P. C. F.)
- Beveled dress.** *See* Spring set.
- Bevel siding.** A board cut in standard lengths and either 4 or 6 inches wide, which tapers to a thin point on one edge. It is used to cover the sides of buildings. (Gen.) *See* Clapboard; Lap siding.  
Syn.: siding, weather board.
- Bilge saw.** A cylinder saw, the center of which is of greater diameter than either end. It is used in cutting small cooperage stock. (Gen.) *See* Cylinder saw.
- Bill of lumber.** An order of lumber. (Gen.)
- Bird's-eye, a.** A piece of lumber is said to have a bird's-eye figure when numerous circlets are found on its surface. Bird's-eye is found only on plain-sawed lumber of a few species. (Gen.)  
Syn.: landscape.
- Bit, n.** 1. A tooth used in an inserted-tooth saw. (Gen.)  
Syn.: inserted tooth, point.  
2. The knives used on the cutter heads of surfacing machines to cut a tongue and a groove. (Gen.)
- Black cypress.** *See* Red cypress.
- Blank, n.** The rough sawed pieces from which axles, spokes, handles, chair rounds and other turned stock are made. (Gen.) *See* Spoke billet.
- Block setter.** One who operates the set-works on a sawmill carriage. (Gen.)  
Syn.: ratchet setter, setter.
- Blower dry kiln.** A dry kiln in which the air is heated by steam coils located outside of the drying room, and is forced into the latter by means of a fan. (Gen.)
- Blued lumber.** Lumber, the sapwood of which has been stained by fungi. (Gen.)  
*See* Sap stain.
- Bluing, n.** The result of fungous attack, which turns the sapwood of certain trees blue. (Gen.)
- Board, n.** 1. A piece of sawed lumber 1 inch in thickness and varying in width, usually by even inches, from 4 to 12 inches. A term sometimes applied to 1-inch stock of all widths.  
2. Lumber 8 feet or more in length, 6 inches or more in width and up to but not including 1½ inches in thickness. (English markets.)
- Board dog.** *See* Carriage dog.
- Board foot.** A unit of measure in the lumber trade. A board foot is a section 12 by 12 inches in size and 1 inch thick, or its equivalent. (Gen.)
- B. M.** Board measure. (Gen.)

- Board mill.** A sawmill that makes a specialty of 1- and 2-inch lumber, as compared to a timber mill which makes a specialty of material of greater thicknesses. (Gen.)
- Bolter, n.** A machine consisting of one or more circular rip saws for cutting small squares from slabs and lumber. Often used at hardwood plants to manufacture rough vehicle, furniture, and similar stock. (Gen.) *See* Knee bolter.
- Box a log, v.** To throw a log from the log trough upon the mill deck, by means of a log kicker. (P. C. F.)
- Box boards.** Lumber from which boxes are manufactured. In some grading rules a specific quality of lumber. (Gen.) *See* Wagon box boards.
- Box dolly.** A lumber-carrying truck which has a single wide-tired wheel in the center of the box frame. Used in loading timbers on vessels. (S. F.)
- Box shooks.** Pieces of lumber cut to size for boxes, but which have not yet been made into a box. (Gen.)  
Syn.: shook.
- Box the heart, v.** In sawing timbers in a sawmill, to cut boards from all sides of the heart, leaving the center as a piece of timber. (Gen.)
- Break down, v.** 1. To reduce large logs to a size which can be sawed on the main log saws in a sawmill. (P. C. F.)  
2. To cut a log into cants. (P. C. F.)  
3. To stop a mill or machine because of an accident. (P. C. F.)
- Briar dress.** *See* Spring set.
- Bright sap.** Sap which is not stained. (Gen.)
- Broadleaf, a.** *See* Hardwood.
- Buffer.** *See* Bumper.
- Buggy.** *See* Lumber buggy; Trolley.
- Bull chain.** 1. *See* Jack chain.  
2. An endless chain traveling in a trough between the sawmill pond and log deck and used to bring logs into a sawmill. A log is attached to the bull chain by means of a short chain having a hook at one end which is caught in a link of the bull chain and two log dogs at the other end which are driven into the log.
- Bull edger.** *See* Rift gang edger.
- Bull head, v.** A term used by saw filers to denote the action of a saw when it leads in or out of a cut. (Gen.)
- Bull wheel.** *See* Log turner.
- Bumper, n.** In a sawmill, a device placed at each end of the carriage run to absorb the shock of the carriage when it has traveled to the extreme end of the track. (Gen.)  
Syn.: buffer.
- Burner, n.** *See* Refuse burner.
- Butt, n.** The base of a tree, or the big end of a log. (Gen.)
- Butt, v.** *See* Trim.
- Butt cut.** 1. The first log above the stump. (Gen.)  
Syn.: butt log. (Gen.)
- Butting saw.** *See* Cut-off saw.
- Butt saw.** *See* Cut-off saw; Drag saw.

**Butt-saw man.** On a timber dock, one who operates a butt saw. (Gen.)

**Byrkit lath.** A patent backing for plaster which is made from low-grade lumber manufactured into a special pattern. (Gen.)

Syn.: patent lath, sheathing lath.

**Caliper measure.** A method of measuring square or roughly hewn logs. The thickness and breadth of the log is calipered at the middle and the cubic content determined as follows:  $\frac{B \times T \times L}{144} = C$ , in which  $B$  equals the breadth,  $T$  the

thickness,  $L$  the length, and  $C$  the cubic feet content. All breadth and thickness measurements are taken to the nearest one-fourth inch. Length measurements for logs containing less than 5 cubic feet are taken to the nearest one-fourth foot, and the contents to the nearest one-tenth cubic foot; logs containing more than 5 cubic feet, 8 inches square or under  $10\frac{1}{2}$  feet in length, have their length measured to the nearest one-half foot and the cubic content calculated to the nearest one-half cubic foot, while logs over 9 inches square and more than  $10\frac{1}{2}$  feet long have their length measured to the nearest one-half foot, with all fractional cubic feet rejected. (U. K.)

See Hoppus String Measure: Liverpool String Measure.

**Cant, n.** A log which has been slabbed on one or more sides. (Gen.)

**Cant a log, to.** To remove slabs from one or more sides of a log. (Gen.)

**Cant flipper.** In a sawmill, two or more horizontal bars placed in a line of live rollers; the outer ends are fastened to a common shaft attached to the piston of a steam cylinder, and the near ends are pivoted to a firm support. On elevating the outer ends, cants and boards are transferred at right angles to direction of travel to a temporary storage point behind the gang saw, resaw, or edger. (Gen.)

**Cant setter.** In a sawmill, one who places the cants in position for the gang saw. (Gen.)

**Carriage, n.** A frame on which are mounted the head blocks, set-works, and other mechanisms for holding a log while it is being sawed, and also for advancing the log towards the saw line after a cut has been made. The carriage frame is mounted on trucks which travel on tracks, the carriage being actuated by a steam feed, a cable, or a rack-and-pinion device, which propels it back and forth past the head-saw. (Gen.)

Syn.: saw carriage.

**Carriage dog, n.** A steel tooth-like projection, several of which are attached to a carriage knee and operated by a lever. Carriage dogs are used to hold the log firmly on the carriage. (Gen.)

Syn.: board dog P. C. F. dog.

**Carriage feed.** A device used to drive the sawmill carriage back and forth. It may consist of a rack-and-pinion, a cable and sheaves, or a large steam cylinder equipped with a piston which actuates the carriage. In large mills the steam cylinder is used for short carriages and the cable for long carriages. In portable mills the rack-and-pinion or the cable feed is used. (Gen.)

**Carriage offset.** See Carriage receder.

**Carriage receder.** A device on the underside of a sawmill carriage which, on the zig back of the carriage, automatically shunts the carriage frame on its axles about  $\frac{1}{2}$  inch away from the saw line. The carriage receder is used only in band sawmills to prevent the log tearing the band saw from the wheels. (Gen.)

Syn.: carriage off-set.

**Carriage rider.** *See* Dogger.

**Carriage trailer.** An extension section of a log carriage which may be attached or detached at will. The carriage trailer permits the sawing of long logs with a comparatively short carriage. (Gen.)

**Case harden.** In seasoning lumber, a piece is said to be case hardened when the exterior becomes very dry while the interior remains moist. This usually is due to the application of a high degree of heat in a short time. (Gen.)

**Casing, n.** A form of interior trim used for window and door cases. (Gen.)

**Catamaran, n.** A small raft often carrying a windlass and grapple, used to recover sunken logs. (Gen.)

Syn.: sinker boat (Gen.), gunboat, monitor, pontoon (P. C. F.).

**Ceiling, n.** A pattern of lumber finished on one or both sides which is used for wainscoting, ceiling, and like purposes. (Gen.)

**C. & E. B.** Center and edge bead. (Gen.)

**C. & E. V.** Center and edge V. (P. C. F.)

**Center bead (C. B.).** A partition or ceiling strip which has a bead pattern running lengthwise of the board. (Gen.)

**Center-sawed.** *See* Quarter-sawed.

**Chain sorter.** One who pulls lumber from the assorting table of a sawmill and piles it on trucks or other vehicles for transportation to the dry kilns or drying yards. (Gen.)

Syn.: sorter.

**Chamber, n.** *See* Throat.

**Chamber, v.** *See* Gum.

**Chambering machine.** *See* Gummer.

**Check, n.** A longitudinal crack in timber caused by too rapid seasoning. (Gen.)

Syn.: seam, season check.

**Checker, n.** One who counts the number of pieces of lumber as they are loaded on a vessel or into a car. (Gen.) *See* Tallyman.

**Chimney, n.** An opening left from top to bottom of a lumber pile to facilitate the circulation of air and to hasten seasoning. (Gen.)

**Chip breaker.** A pressure bar in front of the cutter knives in a planing machine which is designed to prevent splinters from being torn from the face of a board as it passes through the machine. (Gen.)

**Chipped grain.** A machine defect in surfaced lumber, the grain of the wood having been torn out in small particles by the action of the planer knives. (S. F., P. C. F.)

**Chipper, n.** *See* Hog.

**Christiana standard.** A European lumber measurement based on a piece  $1\frac{1}{4}$  inches by 9 inches in cross-section by 11 feet in length, equal to  $10\frac{5}{16}$  feet, board measure. One hundred and twenty (120) standards are known as a Christiana standard hundred, equal to  $1237\frac{1}{2}$  feet, board measure.

*See* Drammen standard, London standard, Quebec standard, St. Petersburg standard.

**Christiana standard hundred.** *See* Christiana standard.

**Churn butted** *See* Swell butted.

- Circular gang mill.** A machine having a battery of circular saws, from 22 to 26 inches in diameter, all of which are fitted to the same shaft. They usually are spaced to cut 1-inch flooring strips from 4- or 6-inch cants. The saws are sometimes mounted on one end of the edger arbor. (Gen.)
- Circular saw.** A circular plate having cutting teeth on the circumference. (Gen.)  
*See* Solid-tooth circular saw.  
 Syn.: rotary saw.
- Circular Sawmill.** 1. A sawmill which has a circular head-saw. (Gen.)  
 2. The mechanism which drives a circular head-saw. (Gen.)
- Clamp, n.** In fluming lumber, a short iron bar with recurved ends which is used to bind several boards together into a bundle. (Cal.)
- Clapboard, n.** A quarter-sawed board, either 4 or 6 inches wide and 4 or 6 feet long, which tapers to a thin point on one edge. It is used to cover the sides of buildings. (N. F.) *See* Bevel siding; Lap siding.
- Cleaner.** *See* Raker.
- Clean-up man.** One who cleans up the refuse in a sawmill or planing mill. (Gen.)
- Clear lumber.** Lumber practically free from all defects. (Gen.)
- Clip, v.** *See* Trim.
- Clipped board.** A board which has been trimmed square on the end. (Eastern markets.)
- Clipperman, n.** One who operates a shingle machine. (P. C. F.)
- Coarse grain.** As applied to the grain of lumber, that which has wide annual rings. (Gen.)
- Comb-grained.** The best quality of quarter-sawed lumber, the growth rings of which are nearly or quite at right angles to the face of the board. (Gen.)  
*See* Quarter-sawed.
- Common boards.** In southern yellow pine, the term applied to four grades of 1-inch lumber of a quality inferior to finishing lumber. The widths run, by even inches, from 8 to 12 inches. In Pacific Coast woods the widths range, by even inches, from 4 to 12 inches.
- Common dimension.** In southern yellow pine 2-inch stock ranging, by even inches from 4 to 12 inches in width. In Pacific Coast lumber, 2-inch stock ranging from 3 to 12 inches in width, and 3-inch stock ranging, by even inches, from 6 to 12 inches in width.  
 Syn.: dimension.
- Compound wood.** *See* Laminated wood.
- Concave saw.** A circular saw, concave in form, which is used to cut chair, cooperage, and vehicle stock. (Gen.)
- Constantine inspection.** *See* Constantine measure.
- Constantine measure.** A system of log measurement in the New York market used in measuring square-hewed foreign woods, chiefly mahogany and cedar logs. From first-class hewed timber, there is deducted 2 inches width from one face and 1 inch from the other face at right angles to it, this deduction being made to straighten the log and to remove axe marks. The face measurements are then used to compute the cubical contents of the log. If the log is defective the contents are reduced one-half.  
 Syn.: Constantine inspection.

- C. I. F.** A marine shipping term, "cost, insurance, and freight," meaning that the seller delivers the goods to the carrier and agrees to pay all charges to bill-of-lading destination. On delivery to buyer of the bill-of-lading with insurance policy attached the seller's responsibility ceases.
- C. I. F. E.** Cost, insurance, freight, exchange. (Gen.)
- Course, n.** A single layer of boards in a pile of lumber. (Gen.)  
Syn.: round.
- Cove siding.** *See* Drop siding.
- Cross-cut, v.** To cut a board or timber at right angles to the general direction of the fibers. (Gen.)
- Cross grain.** As applied to the grain of lumber, a piece in which the wood elements interweave and are not constant in any one direction. (Gen.)  
Syn.: spiral grain.
- Cull, v.** *See* Grade.
- Cull or Peck.** A grade of cypress comprising pieces below No. 2 common and also those cut from the "pecky" part of a log. (S. F.)
- Culler, n.** 1. One who assorts staves as they leave the saw. (S. F.)  
2. *See* Grader.
- Cupping.** In a sawmill, a term applied to the action of a band saw which cuts thick and thin lumber. (Gen.)  
Syn.: running.
- Curly grain.** As applied to the grain of lumber, pieces in which the fibers undulate but do not cross each other. When the undulations are large, wood is said to be wavy grained.
- Custom sawing.** The sawing of lumber under contract, usually to given specifications. (Gen.)
- Cut, n.** The output of a sawmill for a given period of time. (Gen.)  
Syn.: output.
- Cut-off man.** One who operates a cut-off saw in a sawmill. (Gen.)
- Cut-off saw.** A circular or band saw used in a sawmill or other woodworking establishment to cross-cut logs, timbers, and boards. (Gen.) *See* Deck saw.  
Syn.: butt saw, butting saw.
- Cutter head.** A block attached to a driving shaft of a planing machine on which is mounted one or more cutting knives. (Gen.)
- Cylinder saw.** A steel shaft and a cast-iron head to which is fastened a steel drum or cylinder, the walls of which are parallel with the mandrel for the entire length. The cutting edge consists of a toothed steel band attached to the free end of the drum. *See* Bilge saw.  
Syn.: barrel saw.
- Dado-head saw.** A grooving saw which can be adjusted to cut any size groove by the insertion of one or more cutter heads between two outside saws of special pattern. (Gen.) *See* Grooving saw.
- Deadhead, n.** A sunken or partly sunken log. (Gen.)  
Syn.: bobber (N. F.), sinker (Gen.)
- Dead rollers.** Rollers, used for the handling of lumber, which are not power driven. (Gen.) *See* Live rollers.

- Deal, *n.*** 1. In the southern yellow pine export trade, pieces 9 inches and up in width and 3, 4, or 5 inches in thickness. (S. F.)  
 2. A piece of any width and 3 inches and up in thickness is known as a "Quebec deal" in English markets. (E. C.)  
 3. A piece of lumber 12 feet or more in length, from 6 to 11 inches in width and from 2½ to 4½ inches in thickness. (English markets.)

**Deck, *n.*** *See* Log deck.

**Deck man.** In a sawmill, one who keeps straight the logs on the deck and rolls them down for loading on the carriage. (Gen.)

**Deck saw.** A saw used in cross-cutting logs as they rest in the log trough. (Gen.)  
*See* Cut-off saw.

**Deck scaler.** One who scales logs on the deck of a sawmill and also operates the levers controlling the log kicker. (Gen.)

**Deck stop.** *See* Log-stop and loader.

**Density rule.** An authorized and approved set of specifications of the Southern Pine Association and the West Coast Lumbermen's Association for grading structural timbers of southern yellow pine and Douglas fir. (Gen.)

**Dial.** *See* Set-works scale.

**Dimension, *n.*** 1. As applied to hardwood lumber, a term loosely used, but generally referring to small squares used for furniture and like purposes. (Gen.)  
*See* Common dimension.

2. Any lumber cut to size, but especially large timbers cut to order. (E. C.)

**Dimension board.** *See* Stock boards.

**Dimension planer.** *See* Sizer.

**Dimension shingles.** Those which are cut in uniform widths and only one width packed in a bundle. (Gen.)

**Dip, *v.*** To immerse in a solution designed to prevent sap stain. (Gen.)

**Dipping vat.** A tank containing a solution into which lumber is dipped in order to prevent sap-stain. (S. F.)

**Distribute lumber, to.** To take lumber to the yard and leave it at the proper pile. (Cal.) *See* Tram.

**Dock, *n.*** 1. An elevated structure at the rear of a sawmill on which sawed products are stored and from which they can be loaded into or upon cars or ships by gravity. (Gen.)

Syn.: ramp, timber dock.

2. *See* Dollyway.

**Dock man.** At a sawmill plant, one who aids in handling timbers on the loading dock.

Syn.: loader, skid man.

**Dog, *n.*** *See* Carriage dog.

**Dog board.** *See* Backing board.

**Dogger, *n.*** One who rides on a sawmill carriage and handles a lever which operates the "dogs" that hold the log. The dogger on the forward end of the carriage is sometimes called the "head-end dogger," and the one on the rear end, the "rear-end dogger." (Gen.)

Syn.: carriage rider.

**Dogging jaws.** *See* Log dog.



- Dolly, n.** 1. A roller set in a square frame on which timbers are placed when they are to be moved by hand from one place to another. (P. C. F.)  
Syn.: timber roller.  
2. See Lumber buggy.
- Dollyway, n.** An elevated tramway which runs from the sawmill to the drying yard and over which lumber is transported. (Gen.)  
Syn.: dock.
- Dote, n.** The general term used by lumbermen to denote decay or rot in timber. (Gen.)
- Doty, a.** Decayed. (Gen.)  
Syn.: dozy.
- Double circular mill.** One having a top saw. (Gen.)
- Double-cutting band saw.** A saw which is toothed on both edges and is designed to saw on both the forward and rear travel of the carriage. (Gen.)
- Double mill.** A sawmill having two head-saws. (Gen.)
- Dozy, a.** See Doty.
- Drag saw.** A reciprocating saw blade, driven either by a piston actuated by a steam cylinder or by a walking beam, which is used to cross-cut logs. (Gen.)  
Syn.: butt saw.  
See Steam bucking saw.
- Drammen standard.** A Norwegian unit of lumber measurement. It is based on a piece  $2\frac{1}{2}$  inches by  $6\frac{1}{2}$  inches in cross-section by 9 feet in length, equal to  $12\frac{3}{16}$  feet board measure. One hundred and twenty (120) standards are called a Drammen standard hundred, equal to  $1462\frac{1}{2}$  feet, board measure.  
See Christiana standard, London standard, Quebec standard, St. Petersburg standard.
- Drammen standard hundred.** See Drammen standard.
- Dress, v.** See Surface.
- Dressed and headed (D. and H.).** A flooring strip is dressed and headed when it has been surfaced, tongued, and grooved, and also has a tongue on one end and a groove on the other so that the boards need not join over a joist. (Gen.)
- Dressed and matched (D. and M.).** Boards which have been surfaced, tongued, and grooved. (Gen.)
- Dressed lumber.** Lumber which has been dressed or surfaced on one or more sides. (Gen.)
- Drop siding.** A pattern of lumber used to cover the exterior sides of buildings. (Gen.)  
Syn.: cove siding, German siding, novelty siding, patent siding, siding. (Gen.)  
rustic siding (P. C. F.)
- Dry kiln.** A structure in which lumber is dried by artificial heat. (Gen.)  
Syn.: kiln, lumber kiln.
- Dry mill.** A sawmill which has no log pond. (Gen.)
- Dry rot.** Decay in timber without apparent moisture. (Gen.)
- Dublin standard.** See London standard.
- Dump, n.** 1. A term applied to portable mill lumber yards. (New Jersey.)  
2. See Pit.

- Dunnage, *n.*** 1. Lumber of a grade below that recognized in lumber market quotations. Cull lumber usable for certain purposes. (P. C. F.)  
2. The stakes and strips used in holding lumber on open cars and any other lumber that may be needed to protect such shipments. (Gen.)
- Dutch oven.** An extension front used with boilers burning sawdust and similar fuel. It provides greater fuel space and permits more complete combustion. (Gen.)
- Edge, *v.*** To make square-edged. (Gen.)
- Edge-grained (E. G.).** See Quarter-sawed.
- Edger, *n.*** A machine used in sawmills to square-edge waney lumber and also to rip lumber. It consists of a frame supporting an arbor on which are mounted several circular saws, feed rolls, press rolls, and transmission gears. (Gen.)
- Edger helper.** See Tripper.
- Edgerman, *n.*** One who feeds boards into an edger. (Gen.)
- Edge sorter.** 1. A lumber sorting device consisting of grooves in which the lumber is placed on edge. Lines of live rollers, arranged under the grooves, carry the lumber to the desired point. (Gen.)  
2. One who operates an edge sorter.
- Edge stacker.** A machine which stacks lumber on edge on dry kiln trucks. (Gen.)  
See Stacker.
- Edger tables.** Tables with rollers which are placed both in front of and behind the edger. (Gen.)
- Edger tailer.** In a sawmill, one who removes the strips and edgings from the roller at the rear of the edger. (Gen.)  
Syn.: strip catcher, tail edger.
- Edging grinder.** See Hog.
- Edgings, *n.*** The waste strips cut from the edges of boards. (Gen.)  
Syn.: strips.
- Encased knot.** A knot surrounded wholly or partially by pitch or bark. (Gen.)
- End butt, to.** See Trim.
- End match, *v.*** To tongue and groove the ends of matched lumber. (P. C. F.)  
See Dressed and headed.
- End-pile, to.** To pile lumber on end. A method sometimes employed in storage sheds, both at the manufacturing plant and at retail yards. (Gen.)
- Equalizer, *n.*** A machine with two circular saws which is used to trim the ends of lath bundles and stave bolts. (Gen.) See Trimmer.  
Syn.: equalizing machine.
- Equalizing machine.** See Equalizer.
- Evans third saw.** A machine having four circular saws formerly used to break down large redwood logs. (P. C. F.)
- Excelsior, *n.*** Long string-like shavings made from wood and used as a filler for mattresses and as a packing material. (Gen.)
- Ex-quay.** A marine shipping term signifying that the shipper agrees to deliver the goods to the buyer on the quay at bill-of-lading destination with all quay charges, including measurement, rent, master portorage, insurance, watching, and like charges paid, until such time as the buyer takes delivery of the goods according to the custom of the port. (U. K.)

- Ex-ship.** A marine shipping term signifying that the shipper's responsibility continues until the goods are delivered overside at bill-of-lading destination, after which time it ceases. (U. K.)
- Face, *n.*** The lower concave portion of a saw tooth. (Gen.)
- Face count.** In surfaced lumber, the measurement of the actual area as contrasted to the measurement of the area of the rough strip from which it was made. (Gen.) *See* Strip count.
- Face measure.** *See* Surface measure.
- Face side.** In grading rough or S 2 S softwood boards, that side which shows the best quality, while on boards S 1 S the surfaced side is the face side. Hardwoods are usually graded from the poorer or face side.
- F. A. S.** 1. A shipping term "free alongside," which denotes that the price includes delivery alongside the vessel without cost to the buyer. (Gen.)  
2. An abbreviation used by hardwood lumbermen to designate the combined grade of Firsts and Seconds.
- Fast.** In saw filing, a saw, when raised up, is said to be "fast" in those places that come up to the straight edge. (Gen.)
- Fathom, *n.*** An English measure for pit timbers equivalent to 216 cubic feet.
- Feather-edge.** A board which is thinner on one edge than it is on the other is said to have a feather-edge. (Gen.)
- Feed, *n.*** In sawing lumber, the linear length of log, expressed in inches, which is cut at each revolution of the saw. (Gen.)
- Feed rolls.** Live rollers with a smooth, corrugated or rough surface, which are used to feed lumber into an edger, resaw, planer, or other machine. (Gen.)  
*See* Live rollers.
- Fencing, *n.*** A grade of softwood lumber usually 4 or 6 inches in width. (Gen.)
- Fiber-saturation point.** In seasoning wood, that point at which all the free water has been driven off and the cell walls begin to dry. (Gen.)
- Figure-grained.** *See* Quarter-sawed.
- File a saw, to.** *See* Fit a saw, to.
- Filer, *n.*** One who fits saws in a sawmill or other woodworking plant. (Gen.)
- Fine grain.** Wood is said to have a fine grain when the annual rings of growth are narrow. (Gen.)
- Finish, *n.*** The higher grades of lumber. (S. F., L. S.)  
Syn.: finishing, uppers.
- Finishing.** *See* Finish.
- Firm red heart.** Firm heartwood which has a reddish color due to decayed wood adjacent to it. It is an incipient stage of red rot. (S. F.)  
Syn.: red heart.
- First open water.** *See* F. O. W.
- Firsts and Seconds.** *See* F. A. S.
- Fit a saw, to.** To put it into proper condition for sawing. (Gen.)  
Syn.: file a saw, to.
- Five-ply veneer.** A piece of built-up veneer composed of five pieces glued one to the other. *See* Laminated wood.
- Flat grain (F. G.).** *See* Plain-sawed.

- Flitch, *n.*** A thick piece of lumber with wane on one or both edges. (Gen.)
- Floorer, *n.*** A type of planer-and-matcher used to manufacture flooring (F. C. F.).  
*See* Planer-and-matcher.
- F. O. B.** A shipping term, "free on board," which denotes that the price quoted includes loading on the car or vessel. (Gen.)
- F. O. B. Cars,—cent rate.** A trade term signifying that the price quoted includes the f. o. b. mill price plus a specified number of cents per 100 pounds freight charge on the net weight of the lumber. The shipper thereby limits his liability for freight charges. (Gen.)
- F. O. R.** A shipping term, "free on railway." (U. K.)
- F. O. T.** A shipping term, "free on trucks," usually railway trucks. (U. K.)
- F. O. W.** A marine shipping term, "first open water," referring to shipments through ports which, during certain periods of the year, are closed by ice. Contracts made f. o. w. while the port is closed are for shipment as soon as the water is sufficiently free from ice to permit the resumption of boat service. (U. K.)
- Free on board.** *See* F. O. B.
- Friction nigger.** A long toothed lever arm actuated by a friction device which is used to turn logs on a sawmill carriage. (Gen.) *See* Steam nigger.
- Free alongside.** *See* F. A. S.
- Free on railway.** *See* F. O. R.
- Free on trucks.** *See* F. O. T.
- Furnace kiln.** A kiln heated by means of large drums which receive their heat from furnaces located under the kiln. (Gen.)
- Furring.** A narrow strip of 1-inch lumber which is nailed to rafters, studding, and joists as a backing for lath. (Gen.)
- Gang edger.** An edger that has fixed saws. (Gen.)
- Gang mill.** A lumber sawing machine with a heavy frame supporting a sash which carries straight saw blades. The sash works in vertical slides and is driven by a pitman from below. (Gen.)  
*Syn.*: sash-gang mill.
- Gang-saw.** A ribbon of steel from 6 to 10 inches wide and from 44 to 48 inches long which is toothed on one edge. A number of these saws are stretched in the sash of a gang mill. They cut only on the downward stroke. (Gen.) *See* Mulay saw; Sash saw.
- Gang sawyer.** One who has charge of the mechanism of the gang mill. He also controls the rate of speed at which logs are sawed. (Gen.)
- Gang tailer.** In a sawmill, one who takes care of the lumber as it comes from the gang mill. (Gen.)
- Gangway.** *See* Log haul-up.
- Gate saw.** *See* Sash saw.
- Gauge, *n.*** 1. The thickness of a saw blade. In the United States it is measured according to the Stubbs wire gauge. (Gen.)  
2. A scale for measuring the thickness of a saw blade. (Gen.)  
3. *See* Set-works scale.
- Georgia pine.** A trade name for southern yellow pine lumber from the Atlantic coast region. (Gen.)

- German siding.** *See* Drop siding.
- Gig a carriage, to.** Reversing the run of a sawmill carriage after a board has been cut from the log. (Gen.)
- Gobb, n.** *See* Sticker.
- Grade, n.** A term referring to the quality of lumber. (Gen.)
- Grade, v.** To assort lumber and classify it according to quality. (Gen.)  
Syn.: cull (E. C.), inspect, survey (N. F.).
- Grader, n.** One who inspects and classifies lumber according to the defects present. (Gen.)  
Syn.: culler (E. C.), scaler, inspector.
- Grading rules.** Specifications by which lumber is grouped according to quality. (Gen.)
- Grain, n.** In wood, a term used with reference to the arrangement or direction of the wood elements and to the relative width of the growth rings. To have a specific meaning it must be qualified. (Gen.)
- Green lumber (G.).** Lumber, the moisture content of which is greater than air-dried lumber. Unseasoned. (Gen.)
- Green planer.** A planing mill in which green lumber is surfaced. (Gen.)
- Grooved roofing.** Boards with two or more semi-circular grooves worked on the face which are used for the roofs of farm and similar buildings. (Gen.)
- Grooving saw.** A small circular saw of special pattern adapted for cutting a groove in a board. (Gen.) *See* Dado-head saw.
- Gross hundred.** As referring to European lumber measurement, 120 pieces which comprise a standard hundred.
- Gullet.** *See* Throat.
- Gum, v.** To grind out the throats of a saw. (Gen.)  
Syn.: chamber.
- Gummer, n.** A tool used to cut out the throats of a saw. (Gen.)  
Syn.: chambering machine.
- Gun boat.** *See* Catamaran.
- Hammer a saw, to.** To pound it with a special type of hammer in order to adjust the tension. (Gen.)
- Hand planer.** A hand-feed surfacing machine with a single cutter head. (Gen.)  
Syn.: jointer.
- Hang a saw, to.** In a sawmill, to place a saw in position ready for operation. (Gen.)
- Hardwood, a.** As applied to lumber, that which is cut from dicotyledons. (Gen.)
- Head block.** That portion of the sawmill carriage on which the log rests. Each head block consists of a base, a knee, a taper set, dogs, and a rack-and-pinion gear, or some similar device for advancing the knees toward or withdrawing them from the saw line. (Gen.)
- Head-end dogger.** *See* Dogger.
- Heading, n.** The pieces of lumber from which a keg or barrel head is cut. (Gen.)
- Heading chipper.** A machine for dressing heading to any thickness. (Gen.)
- Heading rounder.** A machine for rounding heading. (Gen.)  
Syn.: heading shaper.

**Heading shaper.** *See* Heading rounder.

**Head-saw.** The log-cutting saw in a sawmill. (Gen.)

Syn.: log saw.

**Head sawyer.** *See* Sawyer.

**Heavy joists.** In southern yellow pine, 2-inch stock, 14 inches wide, and also 2½-inch and 3-inch stock which ranges, by even inches from 10 to 14 inches wide.

**Hedgehog, n.** A set of cone-shaped live rollers with a spiked or roughened surface. It is used in dry-land shingle mills for bringing the logs to the drag saw, being substituted for a log jack and a jacker chain. (P. C. F.)

**Hell.** *See* Refuse burner.

**Log, n.** A machine used for cutting wood into chips. Often used to convert sawmill and planing mill refuse into fuel; also to reduce pulpwood to chips. (Gen.)

Syn.: chipper (E. C.), edging grinder, refuse grinder.

**Hoist, n.** (Lum.) *See* Log haul-up.

**Holder.** *See* Shank.

**Hollow-backed (H. Bk.).** A board is said to be hollow backed when a small amount of wood has been removed from the central part of the back side in order to reduce its shipping weight. (Gen.)

**Hollow-horned.** *See* Honey-combed.

**Honey-combed, a.** Lumber is said to be in a honey-combed condition when numerous large season cracks are present on the surface. (Gen.)

Syn.: hollow-horned.

**Hook, n.** The angle between the face of a tooth and a line drawn from the extreme point of the tooth perpendicular to the back of a band saw, or to the center of a circular saw.

**Hookaroon, n.** A recurved pike, or a pike and a hook fitted to a handle from 36 to 38 inches long. Used in handling cross-ties, lumber, poles, posts, staves, timber, and like products. (Gen.)

Syn.: pickaroon.

**Hoppus String Measure.** A method of measuring the cubic contents of logs and other round timber. The formula for determining the cubic contents is—

$$\left(\frac{G}{4}\right)^2 \times \frac{L}{144} = C,$$

in which  $G$  equals the girth in inches,  $L$ , the length of log in feet, and  $C$ , the cubic contents. In practice the girth is taken at center of log, inside of bark, by means of a string, the quarter girth then being found by doubling the string (girth length) twice and measuring to the nearest quarter-inch. The length ( $L$ ) is measured to the nearest one-half foot. Contents are determined to the nearest one-half cubic foot. When the girth measurement can not be taken inside of bark an allowance is made for bark thickness.

In theory the Hoppus String Measure reduces a round log to its square equivalent. (U. K.) *See* Caliper measure; Liverpool String Measure.

**Horizontal band resaw.** A band resaw which cuts in a horizontal line, as compared to a vertical band resaw which cuts in a vertical line. (Gen.)

**Horn knot.** *See* Spike knot.

**Husk, n.** The frame supporting the arbor and other working parts of a circular head-saw. (Gen.)

**Incinerator.** *See* Refuse burner.

**Inserted-tooth, n.** *See* Bit.

**Inserted-tooth circular saw.** A circular saw on whose periphery are sockets in which removable shanks and bits are inserted. (Gen.)

**Inspect.** *See* Grade.

**Inspector.** *See* Grader.

**Interior trim.** Lumber used for finishing the interior of buildings. (Gen.)

Syn.: trim.

**Irish standard.** *See* London standard.

**Irish standard hundred.** *See* London standard.

**Jack, v.** In lumber piling, to pass boards to the piler on top of the lumber stack. (Gen.)

**Jack chain.** An endless spiked chain which moves logs from one point to another, usually from the mill pond into the sawmill. (Gen.)

Syn.: jacker chain (Gen.), bull chain, log haul chain (P. C. F.).

**Jacker.** *See* Pond man.

**Jacker chain.** *See* Jack chain.

**Jackerman.** *See* Pond man.

**Jack ladder.** *See* Log haul-up.

**Jack slip, n.** *See* Log haul-up.

**Jack works.** *See* Log jack.

**Joiner.** *See* Matcher.

**Jointed flooring.** A flooring strip which has been surfaced and the sides of which, instead of being tongued and grooved, are cut on a slight bevel. Used chiefly in New England for porch floors; sometimes for ship decking.

**Jointer, n.** 1. *See* Hand planer.

2. *See* Knot saw.

**Joist, n.** 1. A piece of dimension or a timber which is used to support the floor of a building. (Gen.)

2. A piece of lumber 8 feet or more in length, from 1½ to 4½ inches in thickness, and from 6 to 12 inches wide. (English markets.)

**Jumper, n.** *See* Swage.

**Jump saw.** A circular saw, the base of whose frame is attached to the piston of a steam cylinder, to an eccentric, or to a shaft, so that the saw frame can be raised or lowered in a vertical line. The saw is placed below a line of live rollers and is used to cross-cut long boards and timbers, the operator elevating the saw between the live rollers for this purpose. (Gen.)

**Kiln.** *See* Dry kiln.

**Kiln-dried saps.** An export grade of southern yellow pine lumber. (S. F.)

**Kiln-dried lumber (K. D.).** Lumber which has been seasoned in a dry kiln and contains less moisture than air-dried lumber. (Gen.)

**Kiln-dried sidings.** *See* Kiln-dried saps.

**Knee, n.** That portion of a sawmill carriage head block which bears the carriage dogs which hold the log while being sawed. It also supports the levers used to operate both the carriage dogs and the taper set. (Gen.)

**Knee bolter.** A machine comprising a circular saw and a small traveling carriage operated by the knee which is used for squaring up shingle bolts and for cutting out defects. (Gen.) *See* Bolter.

Syn.: sapper (P. C. F.)

**Knocked-down, *o.*** As applied to a box, the various parts previous to their assembling. (Gen.)

**Knot saw.** A small circular saw used to cut defects from shingles. (Gen.)

Syn.: jointer, shingle jointer.

**Knot sawyer.** One who operates a knot saw. (Gen.)

**Landscape, *o.*** *See* Bird's-eye.

**Lap siding.** Square-edged boards used to cover the sides of buildings, the lower edge of one board being lapped over the upper edge of the board below. In widths of 6 inches or less the edge is usually beveled, while in greater widths it is not. (Gen.) *See* Bevel siding; Clapboard.

**Large knot.** A knot that is of any diameter greater than 1½ inches. (S. F., P. C. F.)

**Lath, *n.*** A thin, narrow strip of wood nailed to the wall and ceiling, as a backing for plaster. (Gen.)

**Lath binder.** A frame in which laths are placed and the bundle compressed so that it can be tied tightly. (Gen.)

**Lath bolt.** A piece of wood from which laths are manufactured. (Gen.)

**Lath bolter.** 1. A machine having a number of small circular saws which are used to reduce slabs and other material to the proper width for lath manufacture. (Gen.)

2. One who operates a lath bolter. (Gen.)

**Lath bundler.** One who ties laths into bundles. (Gen.)

Syn.: tie man.

**Lath mill.** 1. A mill in which laths are manufactured.

2. A machine having several small circular saws which cut bolted lath material into laths. (Gen.)

**Lath mill shover.** One who feeds lath bolts into a lath mill. (Gen.)

**Left-hand sawmill.** A sawmill in which, when standing on the log deck and facing the rear of the mill, the carriage and saw are on the left hand. (Gen.) *See* Right-hand sawmill.

**Live rollers.** Power-driven rollers used in a sawmill to transport timbers, boards, and slabs. (Gen.) *See* Dead rollers.

**Liverpool String Measure.** A method of measuring the cubic contents of logs and other round timber. The formula for determining the cubic contents is—

$$\left(\frac{G}{4}\right)^2 \times \frac{L}{144} = C,$$

in which  $G$  equals the girth in inches and  $L$  the length of log in feet and  $C$  the cubic contents. The girth measurement is taken by means of a string, at the center of the log, outside of bark, with a standard allowance for the thickness of the latter. The quarter girth is then found by doubling the string (girth length) twice and taking the quarter measurement to the nearest one-half inch. The length ( $L$ ) is taken to the nearest foot, and the cubic contents to the nearest half-foot. Allowance is made for defects. On an average shipment the Liver-



pool String Measure gives results about 5 per cent below the Hoppus String Measure. (U. K.) *See* Caliper Measure; Hoppus String Measure.

**Load.** In European lumber markets, the equivalent of 1680 pounds weight, 50 cubic feet cargo space, or 600 superficial feet of 1-inch thickness.

**Loader, n.** 1. At a sawmill plant, one who loads lumber on a car. (Gen.)  
2. *See* Dock man.

**Log bracket.** *See* Log dog.

**Log chair.** *See* Log dog.

**Log deck.** 1. The platform in a sawmill upon which logs are collected and stored previous to placing them on the carriage for sawing. (Gen.)

Syn.: deck, mill deck.

2. *See* Rollway.

**Log dog.** 1. A metal plate with spuds which is attached to an endless chain used in elevating logs into a sawmill. The spuds catch on the log and enable the chain to carry them up the inclined trough to the mill deck.

Syn.: log bracket, log chair, log saddle, log shoe, log spur.

2. Powerful jaws, operated by a steam cylinder underneath the floor, which are placed in the log trough on the sawmill deck and are used to hold a log while being cross-cut into shorter lengths. One type is operated from overhead.

Syn.: dogging jaws (P. C. F.), log saddle, log seat.

**Log dump.** *See* Rollway.

**Log flipper.** *See* Log kicker.

**Log haul chain.** *See* Jack chain.

**Log haul.** *See* Log haul-up; Log jack.

**Log haul-up.** An inclined plane with a trough up which logs are drawn into a sawmill. (Gen.)

Syn.: gangway, hoist, jack ladder, jack slip, log chute, log jack, log slip, log way, slip (Gen.), log haul (E. C.), log hoist (Cal.).

**Log hoist.** *See* Log haul-up; Log jack.

**Log jack.** 1. The gearing in the sawmill driving the endless chain which elevates logs into the mill. (Gen.)

Syn.: jack works (Cal.), log jacker, log haul, log haul-up, log hoist.

2. *See* Log haul-up.

**Log jacker.** *See* Log jack.

**Log kicker.** A lever device located on the log deck, by means of which logs are thrown out of the log trough upon the deck. (Gen.)

Syn.: log flipper, log roller, log unloader.

**Log lift.** A device sometimes used at sawmill plants on tide-water to elevate logs to the log deck. Logs are floated alongside the mill, parallel with the log deck, and are lifted vertically by chain or cable slings spaced several feet apart. One end of each chain or cable is fastened to the deck and the other end is attached to a power-driven shaft hung on beams above the water.

**Log loader.** *See* Log-stop and loader.

**Log roller.** 1. At a portable sawmill plant, one who assists the sawyer in placing logs on the carriage. (N. F.)

Syn.: juggler, rail sawyer, turner.

2. *See* Log kicker.

**Log run.** In softwoods, merchantable lumber of all grades as it comes from the saw; in hardwoods, the full run of the log with No. 3 common out.

**Log saddle.** *See* Log dog.

**Log saw.** *See* Head-saw.

**Log seat.** *See* Log dog.

**Log shoe.** *See* Log dog.

**Log slip.** *See* Log haul-up.

**Log spur.** *See* Log dog.

**Log-stop and loader.** In a sawmill, a device placed at the base of the deck to hold the logs in place, and also to aid in throwing them upon the carriage. (Gen.)

Syn.: deck stop (P. C. F.), log loader, steam kicker (Gen.)

**Log turner.** 1. A device usually attached to beams over the log deck, consisting of a drum driven by friction gearing, on which is wound a chain or cable used in turning logs on a sawmill carriage. (Gen.)

Syn.: bull wheel, overhead eanter, overhead turner.

2. A device actuated by a steam piston, consisting of two or more arms or skids and a hook which are used to shove or to turn logs on a saw carriage. Especially adapted for handling large and long logs. Its movements are controlled by the sawyer. (P. C. F.) *See* Steam nigger.

Syn.: Simonson log turner, steam log turner.

**Log unloader.** *See* Log kicker.

**Log way.** *See* Log haul-up.

**London standard.** A unit of European lumber measurement. It is based on a piece 13 inches by 9 inches in cross-section by 12 feet in length equal to 27 feet, board measure. One hundred and twenty (120) standards comprise a London standard hundred, equal to 3240 feet, board measure.

Syn.: Dublin standard, Irish standard.

*See* Christiana standard, Drammen standard, Quebec standard, St. Petersburg standard.

**London standard hundred.** *See* London standard.

**Loose.** In circular or band saw fitting, a saw is "loose" in those places which fall away too much from a straight edge. (Gen.)

**Loose knot.** A knot not held firmly in place. (Gen.)

**Lumber, n.** 1. Timber sawed or split for use. (Gen.)

2. Timber sawed or split for use in building; that is, the manufactured product of logs. (Supreme Court of North Carolina, 82 Southeastern, 1036.)

**Lumber, v.** To log or to manufacture logs into lumber, or both. (Gen.)

**Lumber buggy.** A two-wheeled truck for transporting lumber around a sawmill plant and yards. (Gen.)

Syn.: buggy, dolly (Gen.), lumber truck (P. C. F.).

**Lumber gauge.** A tool used to measure the thickness of a board, or to determine the accuracy of the manufacture of the tongue and groove which have been cut on a piece of surfaced lumber. (Gen.)

**Lumber jack.** A stand or tripod, usually armed at the peak with a spike, which is used as a fulcrum in jacking lumber to the top of a lumber pile. (Gen.)

**Lumber kiln.** *See* Dry kiln.

**Lumber piler.** *See* Staeker.

**Lumber stacker.** *See* Stacker.

**Lumber transfer.** A set of lever arms, either power- or hand-operated, which are used to transfer timbers and boards from a set of live rollers to some other conveying device. The new direction of travel usually is at right angles to the original. (Gen.)

Syn.: trip. (P. C. F.)

**Lumber truck.** *See* Lumber buggy.

**Machine feeder.** One who feeds lumber into a machine in a planing mill. (Gen.)  
Syn.: planer feeder.

**Machine tailer.** One who stands at the rear of a surfacing machine and sorts or grades the lumber as it comes from the machine. (S. F.)

**Mandrel, n.** *See* Saw arbor.

**Marker, n.** 1. At a portable sawmill plant, one who takes lumber from behind the saw, scales, marks, and tallies it. (N. F.)

Syn.: scaler, surveyor.

2. One who grades lumber and places the grade symbol on each piece. (P. C. F.)

**Matcher, n.** A surfacing machine used in a planing mill for finishing lumber of average width and thickness. (Gen.)

Syn.: joiner. (P. C. F.)

**Merchantable** (Merch.), *n.* The name of a specific grade of southern yellow pine timbers. (Gen.)

**Merchantable log.** A log that will make lumber of a quality and in sufficient amount to make it profitable to take it to a mill and have it sawed. (Supreme Court of Michigan, S2 Northwest. Reporter, 230.)

**Merchantable lumber.** As applied to the output of a sawmill, the entire cut of the mill, except mill culls. (Gen.)

**Merchantable timber.** Usually interpreted to mean timber that can be manufactured and sold at not less than cost. The purpose for which the timber is to be used and local custom are factors which influence the degree of utilization.

**Mill cull.** 1. The non-merchantable part of the mill cut (Gen.)

2. In hardwoods and some softwoods, a term applied to a specific quality of low-grade lumber.

**Mill deck.** *See* Log deck.

**Mill pond.** A pond in which logs are stored at the sawmill. (Gen.)

**Mill run.** As generally understood, all of the lumber output of a sawmill which has a sale value. (Gen.)

**Mill saw.** *See* Sash saw.

**Mill scale.** The scale of logs made at the rafting boom or at the sawmill. (Gen.)

**Millwright, n.** A skilled mechanic who keeps a sawmill in repair. (Gen.)

**Molder, n.** *See* Molding machine.

**Molding, n.** Interior trim of all kinds. The term often is applied to narrow strips of lumber worked in various patterns which are used to give a finished appearance to an interior. (Gen.)

**Molding machine.** A planing mill machine on which ceiling, molding, and other finished products of small dimensions are made. (Gen.)

Syn.: molder. (P. C. F.)

**Monitor, n.** *See* Catamaran.

**Mulay saw.** A long stiff saw which is actuated by a pitman attached to the lower end. The upstroke is accomplished by means of a spring pole or some similar device. The saw is not stretched in a frame. *See* Gang saw; Sash saw.  
Syn.: Muley.

**Mule-ear knot.** *See* Spike knot.

**Muley.** *See* Mulay saw.

**Natural draft dry kilns.** A dry kiln in which heat is provided by steam pipes within the kiln, circulation of air being secured by means of ducts opening to the exterior. (Gen.)

**Nigger, n.** *See* Steam nigger.

**Nominal measure.** In the European import lumber trade, the full measure of a board before it is surfaced.

**North Carolina pine.** Pine lumber cut in the Coastal Plain region of Virginia, North Carolina, and South Carolina. (S. F.)

**Novelty siding.** *See* Drop siding.

**Odd lengths.** A term applied to lumber the length of which is in odd feet. (Gen.)

**Off-bear.** *See* Off-bearer.

**Off bearer, n.** One who stands directly behind the head-saw in the mill and seizes slabs and boards as they come from the saw, placing them flat on live rollers. (Gen.)

Syn.: off-bear, saw tailer, swamper, tail sawyer, take-away man, slab stripper. (S. F.)

**Offset, n.** A device attached to a sawmill carriage frame and also to one of the axles of the carriage trucks, which automatically shunts the carriage frame away from the saw line when the carriage is giggered back. (Gen.)

**Ogee (O. G.).** One of the most widely used moldings, having a double curve formed by a concave and a convex line. (Gen.)

**Open, v.** *See* Tension.

**Open-fire kiln.** *See* Arkansas dry kiln.

**Open up a saw, to.** To increase the tension. (Gen.)

**Out of round.** A circular saw is said to be "out of round" when its periphery is not a perfect circle. (Gen.)

**Output, n.** *See* Cut.

**Overhang, n.** The forward pitch given to a pile of lumber. (Gen.)

**Overhead canter.** *See* Log turner.

**Overhead saw.** *See* Top saw.

**Overhead trimmer.** A trimmer, the saws of which are hung above the trimmer table. (Gen.) *See* Trimmer.

**Overhead turner.** *See* Log turner.

**Overrun, n.** The difference between the mill cut of merchantable lumber and the log scale. Usually calculated as a per cent of 1000 feet log scale. (Gen.)

**Overside delivery.** Delivery direct from a vessel to a scow or barge.

- Partition, n.** A pattern of lumber used for interior partitions and similar work where both sides of the board are exposed. (Gen.)
- Patent lath.** See Byrkit lath.
- Patent siding.** See Drop siding.
- Pecky, a.** A term applied to a defect common in bald cypress. (S. F.)  
Syn.: peggy.
- Peeler, n.** See Rotary veneer machine.
- Peggy, a.** See Pecky.
- Petersburg standard.** See St. Petersburg standard.
- Petersburg standard hundred.** See St. Petersburg standard.
- Petrograd standard.** See St. Petersburg standard.
- Philadelphia fencing.** A pattern of partition used in the eastern part of the United States.
- Pickaroon.** See Hookaroon.
- Pile, v.** See Stick.
- Pile bottom.** The foundation on which lumber is piled during seasoning in a yard. (Gen.)
- Piler.** See Stacker.
- Piling strip.** See Sticker.
- Pin dote.** Small rotten spots on the ends of logs. (Gen.)
- Pine sawyer.** A beetle of the genus *Monohammus* which attacks the sapwood of pine logs. (S. F.)
- Pin knot.** A knot which is sound and not more than  $\frac{1}{2}$  inch in diameter. (S. F., P. C. F.)
- Pin worm holes.** Small holes in timber and lumber made by the larvæ of certain beetles. (Gen.)
- Pirate, n.** A manufacturer who sells direct to a consumer at a place where retailers are in business. (Gen.)
- Pit, n.** 1. A cleared space at the tail of a portable mill which is used for storing lumber.  
Syn.: dump.  
2. A hole in which the pit-sawyer stands when whip-sawing lumber. (Gen.)
- Pith knot.** A sound knot with a pith hole in the center which is not more than  $\frac{1}{4}$  inch in diameter.
- Pitch, n.** The angle between the back of a tooth and a line drawn from the extreme point of the tooth to the back of a band saw or to the center of a circular saw. (Gen.)
- Pitch pocket.** In coniferous woods, an opening between the annual growth rings containing pitch. (Gen.)  
Syn.: pitch seam. (P. C. F.)
- Pitch seam.** See Pitch pocket.
- Pitch streak.** In coniferous woods, a well-defined accumulation of pitch at one point. (Gen.)
- Pit-saw, n.** See Whip-saw.
- Pit-sawyer, n.** One who stands in the pit below the log and aids in operating a whip-saw. (Gen.)

**Plain-sawed.** All lumber which is not classed as quarter-sawed. (Gen.)

Syn.: bastard grain, flat grain, slash grain.

**Plane, v.** *See* Surface.

**Planer-and-matcher.** A machine used in a planing mill or wood-working factory to surface and match lumber. (Gen.) *See* Floorer. (P. C. F.)

**Planer feeder.** *See* Machine feeder.

**Plank, n.** 1. A piece of lumber from 2 to 3 inches thick. (Gen.)

2. In the southern yellow pine export trade, pieces 7 inches and up in width and from 2 to 2 $\frac{3}{4}$  inches in thickness. (S. F.)

3. A piece of lumber 8 feet or more in length, more than 11 inches in width, and from 1 $\frac{1}{2}$  to 4 $\frac{1}{2}$  inches in thickness. (English markets.)

**Poacher, n.** 1. A retail lumber dealer who encroaches on the sales territory of another dealer. (Gen.)

2. A wholesale lumber dealer who sells lumber to a retail lumberman, and then sells to the same retail lumberman's customers. (Gen.)

**Point, n.** *See* Bit.

**Pointer, n.** *See* Tripper.

**Pole stock.** Lumber used in the manufacture of poles for vehicles. (Gen.)

**Pond man.** One who collects logs in the mill pond and floats them to the log haul-up. (Gen.)

Syn.: boom man, slip man (P. C. F.), jacker (N. W.), jackerman (S. F.).

**Pond saw.** A power-driven saw used to cross-cut logs at a sawmill pond. (Cal.)

**Pontoon, n.** *See* Catamaran.

**Pony Band Mill.** A fully equipped band saw and carriage, smaller than the head-saw, used in Pacific Coast mills to saw flooring, stepping, and 1-inch lumber. It is a substitute for a sash-gang mill and used in connection with the head-saw, enables the operator to manufacture products of many sizes. (P. C. F.) *See* Resaw.

**Porch decking.** A board surfaced and tongued and grooved, the upper face of which has two or more semicircular depressions for carrying off rain water, and the lower surface of which often is beaded for ornamental purposes. It is used for porch roofing. (Gen.)

**Portable mill setting.** *See* Setting.

**Portable sawmill.** A small sawmill which can be readily moved from one place to another. The usual daily capacity varies from 3 to 10 M. board feet. (Gen.)

**Press roll.** A roller which holds the lumber against the feed roll when lumber is being fed into a machine. (Gen.)

**Prime log.** In the export market, one that is free from defects. (Gen.)

**Progressive dry kiln.** A dry kiln in which the lumber is gradually advanced through the kiln, a few cars being taken out of the dry end at certain intervals and the remaining cars advanced to the dry end. The "green" end of the kiln then receives cars of unseasoned lumber. (Gen.)

**Punch bar.** One of the arms on a log kicker. (P. C. F.)

**Quarter-sawed.** In hardwoods, lumber cut parallel or nearly parallel, with the medullary rays. In softwoods, lumber in which the annual growth rings do

not tip more than 45° from the vertical throughout the entire length of the board. (Gen.)

Syn.: center-sawed, comb-grained, edge-grained, figure-grained, rift-sawed, silver-grained, vertical-grained.

**Quebec deal.** *See* Deal.

**Quebec standard.** Formerly a unit for the measurement of deals in transactions between producer and shipper. Now confined to the measurement of Ottawa pine deals. It is based on a piece 3 inches by 11 inches in cross-section by 10 feet in length and contains 27½ feet, board measure. One hundred (100) Quebec standards are known as a Quebec standard hundred.

*See* Christiana standard, Drammen standard, London standard, St. Petersburg standard.

**Quebec standard hundred.** *See* Quebec standard.

**Rack-and-pinion drive.** A form of carriage drive used in portable sawmills. A rack is attached to the underside of one of the beams of the carriage frame and into it meshes a pinion wheel driven from a shaft on the saw husk. (Gen.)

**Radiator dry kiln.** A kiln in which air is heated over coils of steam pipes and then forced by fans into the chamber containing the lumber. (Gen.)

**Ramp.** *See* Dock.

**Random width shingles.** Shingles of widths varying from 2 to 16 inches. There is no uniformity of width in the shingles in each bundle. (Gen.)

**Ratchet setter.** *See* Block setter.

**Rear-end dogger.** *See* Dogger.

**Receder, n.** A device on a sawmill carriage for receding the knees away from the saw line. It may comprise either a coiled spring properly adjusted on the set-shaft, or a system of gears and friction pulleys by means of which the set-shaft can be revolved. (Gen.)

**Receiving boom.** *See* Storage boom.

**Red cypress.** Cypress lumber which has a deep color. (S. F.)

Syn.: black cypress.

**Red heart.** *See* Firm red heart.

**Refuse, n.** That portion of a tree which cannot be removed profitably from the forest or utilized profitably at the manufacturing plant. (Gen.)

**Refuse burner.** An open or enclosed structure in which slabs, sawdust, bark, and other sawmill wood refuse are burned. The open burner consists of a brick, sheet metal, or wire screen erected between the sawmill building and the open fire, while the enclosed type consists of a round brick or steel structure with fire grates at the base and a fire screen over the top to prevent the emission of large sparks. (Gen.) *See* Slab-pit.

Syn.: burner, hell, incinerator.

**Refuse conveyor.** An endless chain traveling in a trough which transports sawmill refuse. (Gen.)

Syn.: slab conveyor.

**Refuse grinder.** *See* Hog.

**Resaw, n.** A circular or band mill which is used to resaw boards, cants, planks, timbers, slabs, and other wood products. (Gen.)

Syn.: slab saw.

- Resaw, *v.*** To cut boards, planks, slabs, or other material into two or more pieces on a resaw. (Gen.)
- Resaw tailer.** In a sawmill, one who takes care of the refuse material and boards as they come from the resaw. (Gen.)
- Resawyer, *n.*** One who operates a resaw. (P. C. F.)
- Rift gang edger.** A machine for sawing cants from 3 to 8 inches in thickness into edge-grained boards or into scantlings. (Gen.)  
Syn.: bull edger.
- Rift saw.** A circular saw having four or more arms which project from the plate and carry the cutting teeth, usually of the inserted type. The indentations between the arms serve as cavities for the storage and removal of sawdust. Rift saws are used in cutting flooring strips from cants. (Gen.)
- Rift-sawed.** *See* Quarter-sawed.
- Riga "last."** A European unit of lumber measurement comprising 960 feet, board measure, of sawed deals or squared timbers.
- Right-hand sawmill.** A sawmill in which, when standing on the log deck and facing the rear of the mill, the carriage and saw are on the right hand. (Gen.)  
*See* Left-hand sawmill.
- Rip, *v.*** To cut a board lengthwise; i.e., parallel to the fibers. (Gen.)
- Rip saw.** A saw which is used to rip lumber. (Gen.)
- Rock saw.** A circular saw or a planer cutter head, driven by a belt, which is suspended by a long arm above a log in front of the head saw. The rock saw removes a wide kerf on the upper surface of the log in the line of the head-saw cut, and its object is to detect the presence of gravel, rafting dogs, and other foreign matter which might injure the head-saw. The shavings and sawdust are removed by a suction hood. (P. C. F.)  
Syn.: barking saw.
- Rock sawyer.** One who operates a rock saw. (P. C. F.)
- Rollway, *n.*** 1. A platform at the mill upon which logs are unloaded from log cars. It may be built around the edge of a pond or along the bank of a stream to aid in dumping the logs into the water, or it may be so built that it is used as a place for dry land storage of logs. (Gen.)  
Syn.: log deck (Cal.), log dump.
- Roof board.** *See* Shake.
- Roofers, *n.*** One-inch lumber nailed to rafters as a backing for shingles. (Gen.)
- Rotary saw.** *See* Circular saw.
- Rotary veneer machine.** A machine that cuts or peels a thin endless sheet of wood from a round log. (Gen.)  
Syn.: peeler.
- Rotten knot.** A knot which is not as hard as the surrounding wood. (Gen.)
- Round knot.** A knot that is oval or circular in form. (Gen.)
- St. Petersburg standard.** A unit of lumber measurement in Europe. It is based on a piece  $1\frac{1}{2}$  inches by 11 inches in cross-section by 12 feet in length, which is equal to  $16\frac{1}{2}$  feet, board measure. One hundred and twenty (120) standards are known as a St. Petersburg standard hundred, equal to 1980 feet, board measure, or 165 cubic feet.  
Syn.: Petersburg standard, Petrograd standard.  
*See* Christiana standard, Drammen standard, London standard, Quebec standard.



- St. Petersburg standard hundred.** *See* St. Petersburg standard.
- Sapper.** *See* Knee bolter.
- Sap stain.** The stain on the sapwood of logs and lumber caused by fungi. (Gen.)  
*See* Blued lumber.
- Sash, n.** The frame in which gang saws and sash saws are stretched. The frame moves up and down in vertical grooves or slides and is actuated by a pitman attached to the base. (Gen.)
- Sash saw.** A ribbon of steel, toothed on one edge, which is stretched in a sash or frame. The saws are used singly. Sash saws are employed only in water-power mills of limited capacity. (Gen.) *See* Gang saw; Mulay saw.  
Syn.: gate saw, mill saw.
- Saw alive, to.** To make all cuts on the log parallel. (Gen.)  
Syn.: saw through and through, to.
- Saw arbor, n.** The shaft and bearings on which a circular saw is mounted. (Gen.)  
Syn.: arbor, mandrel.
- Saw around, to.** In sawing, to cut from three or more faces of a log, the latter being turned in order to get the best quality of lumber. (Gen.)
- Saw bill.** The instructions given to a sawyer for sawing lumber of various kinds and sizes from given logs. (Gen.)
- Saw carriage.** *See* Carriage.
- Saw fitter.** *See* Filer.
- Saw guide.** A device for steadying a saw. (Gen.)
- Saw kerf.** The width of cut made by a saw. (Gen.)
- Sawmill, n.** A plant at which logs are sawed into salable products. It includes all the machinery necessary for the operation of the plant and also the buildings and grounds on which it is located. (Gen.)
- Saw tailer.** *See* Off bearer.
- Saw, through and through, to.** *See* Saw alive, to.
- Saw timber.** Logs suitable in size and length for the production of merchantable lumber.
- Sawyer, n.** One who controls the carriage and other machinery used in sawing logs into lumber. The quality and quantity of lumber sawed depends on his judgment, skill and speed. (Gen.)  
Syn.: head sawyer. (P. C. F.)
- Scaler, n.** *See* Grader; Marker.
- Scalper, n.** One who sells for a commission, lumber in which he has no direct financial interest. (Gen.)
- Scantling, n.** 1. A piece of timber of small size. (Gen.)  
Syn.: stud, studding. (Gen.)  
2. In the southern yellow pine export trade, pieces from 2 by 2 to 2 by 6 inches, from 3 by 3 to 8 by 8 inches, from 4 by 4 to 4 by 8 inches, and from 5 by 5 to 5 by 8 inches in size. (S. F.)
- Scout, n.** Hardwood lumber, all pieces being of a quality inferior to No. 4 Common.
- Screw rollers.** Live rollers, with a coarse spiral thread on the surface, which shunt the piece of lumber or slab to one side so that it will leave the roll. (Gen.)  
Syn.: worm roller.
- Seam.** *See* Check.

- Season, *v.*** To dry lumber, either in the open or in a dry kiln. (Gen.)
- Season check.** *See* Check.
- Season checks.** Cracks which appear on the exterior faces of lumber during the seasoning process. (Gen.)
- Season's cut.** The output of a sawmill plant for that portion of the year the mill is operated. (Gen.)
- Select structural (Sel. struc.).** The name of a specific grade of southern yellow pine timbers. (Gen.)
- Send-in man.** One who has charge of securing and sending to the planing mill such lumber as is called for by the shipping clerk. (Gen.)
- Set beam.** A shaft on a sawmill carriage, directly connected with the set works, bearing pinions one of which meshes into a rack in each head block and moves the knees forward and backward as desired. (Gen.)
- Setter, *n.*** *See* Block setter.
- Setting, *n.*** The temporary station of a portable sawmill. (Gen.)  
Syn.: portable mill setting, set-up.
- Set-up, *n.*** *See* Setting.
- Set-works.** The mechanism on a sawmill carriage by means of which the block setter advances the knees and the log toward the saw line after a piece has been cut from the log. (Gen.)
- Set-works scale.** A disc on a saw carriage which shows the distance in inches between the saw line and the face of the knees. (Gen.)  
Syn.: dial, gauge.
- Shake, *n.*** 1. A form of shingle split from a bolt of wood and used to cover both the roofs and sides of buildings. Those made of sugar pine are 32 inches long, 5 inches wide, and  $\frac{3}{16}$  inch on the thinner edge.  
Syn.: hand-made shingle, roof board. (App.)  
2. A crack in timber, due to frost or wind. (Gen.)  
Syn.: windshake.
- Shake roof.** *See* Split roof.
- Shank, *n.*** A device for locking inserted teeth in a circular saw. (Gen.)  
Syn.: holder.
- Sheathing, *n.*** Lumber used to cover the exterior of buildings. (Gen.)
- Sheathing lath.** *See* Byrkit lath.
- Shingle, *n.*** A thin, oblong piece of wood, with one end thinner than the other, in order to lap lengthwise in covering roofs and outer walls of buildings. (Gen.)
- Shingle bolt.** A short split section of a log from which shingles are manufactured. (Gen.) *See* Bolt.
- Shingle bundler.** *See* Shingle packer.
- Shingle jointer.** *See* Knot saw.
- Shingle mill.** 1. A mill in which shingles are manufactured. (Gen.)  
2. A machine used in making shingles. (Gen.)
- Shingle packer.** 1. One who packs shingles in bundles. (Gen.)  
Syn.: shingle bundler.  
2. *See* Shingle press.
- Shingle press.** A frame in which shingles are packed in bundles.  
Syn.: shingle packer.

- Shingle saw.** A circular saw used to cut shingles from bolts. (Gen.)
- Shingle weaver.** One who works in a shingle mill. (P. C. F.)
- Shiplap, n.** 1. A form of matching for lumber. A section one-half the thickness of the board is cut from the upper side of one edge, and a similar section from the lower side of the opposite edge. (Gen.)  
2. Lumber which has been worked shiplap. (Gen.)
- Ship lumber, to.** 1. To load lumber on cars or vessels for shipment, or to place lumber in the upper end of a flume for transportation. (Gen.)  
2. To transport lumber by rail or water. (Gen.)
- Shipping dry.** A condition of lumber in which the moisture content is the same as that of air-dried lumber. (Gen.)
- Shook, n.** 1. A bundle of planed, seasoned, and jointed staves, containing a complete set for one barrel. (S. F.)  
2. *See* Box shooks.
- Shop, n.** A quality of lumber in several grades which is used in the manufacture of sashes, doors, blinds, and like products. (Gen.)
- Shorts, n.** Lumber shorter than standard lengths. (Gen.)
- Shot-gun, n.** *See* Gun.
- Shot-gun feed.** *See* Steam feed.
- Shot holes.** Holes made in wood by boring insects. (App.)
- Shove-off man.** One who consecutively shoves off the top courses of lumber on a dry kiln truck when the latter is being unloaded. (Gen.)
- Siding, n.** *See* Bevel siding; Drop siding.
- Sidings, n.** Boards sawed from the outer portion of a log when the central part is made into a timber. (N. F.)
- Silver-grained.** Quarter-sawed lumber with conspicuous medullary rays. (Gen.)  
*See* Quarter-sawed.
- Simonson log turner.** *See* Log turner.
- Single band saw.** A saw that has one cutting edge. (Gen.)
- Single mill.** A sawmill having one head-saw. (Gen.)
- Sinker, n.** *See* Deadhead.
- Sinker boat.** *See* Catamaran.
- Sizer, n.** A machine for surfacing timbers. (Gen.)  
Syn.: dimension planer, timber planer. (P. C. F.)
- Skid-off, n.** A launching way for lumber rafts. (S. F.)
- Skips in dressing.** In surfacing lumber, slight depressions in boards which are below the line of cut, and therefore remain in a rough condition. (Gen.)
- Slab, n.** 1. The exterior portion of a log which is removed in sawing lumber. (Gen.)  
2. In a box shook factory, a thin piece of lumber resawed from a board. (Gen.)
- Slab conveyer.** *See* Refuse conveyer.
- Slab man.** One who works on the sawing floor of a sawmill and keeps slabs out of the way of other material. (P. C. F.)
- Slab pile.** A place where slabs and other mill waste is burned or dumped. (Gen.)
- Slab-pit.** An open refuse burner. (S. F.) *See* Refuse burner.
- Slab saw.** *See* Resaw.
- Slab slasher.** *See* Slasher.

**Slab stripper.** *See* Off-bearer.

**Slasher, n.** Several circular saws mounted on a shaft at intervals varying from 16 to 48 inches, and used to cut slabs, edgings and other wood refuse into lengths suitable for laths, firewood, pulpwood, or for transportation to the refuse burner.

Syn.: slab slasher.

**Slasher man.** In a sawmill, one who tends the conveyor chains bearing refuse to the slasher. (Gen.)

**Slash grain.** *See* Plain-sawed.

**Slash knot.** *See* Spike knot.

**Slat, n.** 1. In pencil manufacture, a standard slat is a sawed piece of wood  $7\frac{1}{4}$  by  $2\frac{1}{2}$  by  $\frac{1}{4}$  inches from which pencils are made. (Gen.)

2. A strip used in the manufacture of crates. (Gen.)

**Slat saw.** A small circular saw used in cutting small dimension stock. (Gen.)

**Slip, n.** *See* Log haul-up.

**Slip man.** *See* Pond man.

**Small knot.** In cypress and Pacific Coast woods, a knot that is sound and not more than  $\frac{3}{4}$  inch in diameter.

**Smoke-dried finish.** Lumber that has been seasoned in an Arkansas dry kiln. It is usually blackened on the surface, due to exposure to smoke during the drying process. (S. F.)

**Smoke kiln.** *See* Arkansas dry kiln.

**Snake, v.** In sawing, boards to make a wavy cut in a log. It is an indication of poor sawfitting. (Gen.)

**Softwood, a.** As applied to lumber, that which is cut from coniferous trees. (Gen.)

**Solid-plate circular saw.** *See* Solid-tooth circular saw.

**Solid-tooth circular saw.** A saw in which the teeth are cut into the periphery of the saw. (Gen.)

Syn.: solid-plate circular saw.

**Sorter, n.** *See* Chain sorter.

**Sorting boom.** A boom used to guide logs into the sorting jack, to both sides of which it is usually attached. (Gen.)

**Sorting gap.** *See* Sorting jack.

**Sorting jack.** A raft secured in a stream, through an opening in which logs pass to be sorted by their marks and diverted into pocket booms or into the downstream channel. (Gen.)

Syn.: sorting gap.

**Sorting table.** In a sawmill, a long platform extending from the rear on which lumber is assorted. (Gen.)

**Sort lumber, to.** To take lumber from the assorting table and pile it on cars or trucks in such manner that each species and grade may be taken to the proper part of the yard. (Gen.)

**Second cutting.** In hardwood lumber, a piece that is free from rot and shake.

**Sound knot.** A knot which is solid across its face, as hard as the surrounding wood and so fixed that it will retain its place in the piece. (Gen.)

- Sound merchantable.** As applied to lumber, a non-official, loosely interpreted term which does not represent any established grade. Usually interpreted as lumber that is salable for some specified purpose. (Gen.)
- Sound wormy.** A term applied to a particular quality of oak and chestnut lumber which contains pin worm holes. (Gen.)
- Spalt, n.** The residue of a shingle bolt, after cutting off shingles, which is too narrow to be cut into shingles. (P. C. F.)
- Spiked roller.** Rollers either round or concave, which are armed with spikes and designed to feed logs or slabs against a saw. They usually are power driven. (Gen.)  
Syn.: spiked rolls.
- Spiked rolls.** See Spiked roller.
- Spiked skid.** A skid in which spikes are inserted in order to keep logs from sliding back when being loaded or piled. (Gen.)
- Spike knot.** A knot sawed in a lengthwise direction. (Gen.)  
Syn.: horn knot, mule-ear knot, slash knot. (P. C. F.)
- Spiral grain.** See Cross grain.
- Spline, n.** A rectangular strip of wood which is substituted for the tongue on heavy factory flooring. (Gen.)
- Spoke billets.** The rough sawed pieces from which spokes are turned. (Gen.)  
See Blank.
- Spoke bolt.** See Bolt.
- Spool bar.** Small sawed squares of lumber from which spools are turned. (N. F.)  
Syn.: spoolwood. (E. C.)
- Spoolwood.** See Spool bar.
- Spring set.** A saw is spring set when one tooth is sprung to the right and the next one to the left. Cross-cut saws are spring set; also very narrow band saws. (Gen.)  
Syn.: beveled dress, briar dress. (P. C. F.)
- Square, n.** When applied to shingles, that number which will cover 100 square feet of surface. (Gen.)
- Square dress, n.** See Swage set.
- Square dress, to.** See Swage a saw, to.
- Square Edge and Sound (Sq. Edg-Sd.).** The name of a specific grade of southern yellow pine timbers. (Gen.)
- Stack, v.** See Stick.
- Stacker, n.** 1. One who places lumber in piles. (Gen.)  
Syn.: lumber piler, lumber stacker, piler.  
2. A machine for stacking lumber on dry kiln trucks. See Edge stacker.  
Syn.: lumber piler, lumber stacker.
- Standard, n.** See Christiana standard, Drammen standard, London standard, Quebec standard, St. Petersburg standard.
- Standard band sawmill.** One containing a single band mill and having a rated capacity of 50 M. board feet in 10 hours. (Gen.)
- Standard knot.** 1. A knot that is sound and not over  $1\frac{1}{2}$  inches in diameter. (S. F.)  
Syn.: tight knot (P. C. F.)  
2. In hardwoods and cypress, a knot that is not more than  $1\frac{1}{4}$  inches in diameter.

**Standard lengths.** Lengths into which rough lumber is cut for general use. The standard lengths in southern yellow pine are multiples of 2 feet, from 4 to 24 feet, inclusive. In surfaced products, such as flooring, ceiling, drop siding, and like material, the standard lengths range in multiples of 1 foot, from 4 to 20 feet, inclusive. Hardwood standard lengths run from 4 to 16 feet, inclusive. In the Province of Quebec, Canada, the standard lengths are 12 and 13 feet.

**Stationary sawmill.** A sawmill which has a permanent location, as contrasted with a portable mill which may be moved at frequent intervals. (Gen.)

**Steam bucking saw.** A portable steam saw used for bucking logs at the landing. (Cal.)

Syn.: drag saw.

**Steam dog.** A device operated by a steam cylinder which is placed in the log trough on the deck of a sawmill in order to hold logs while they are being cross-cut into shorter lengths. (Gen.)

**Steam feed.** A long cylinder with a piston which is attached to the rear end of the sawmill carriage and draws the latter back and forth. (Gen.)

Syn.: shot-gun feed.

**Steam kicker.** *See* Log-stop and loader.

**Steam log turner.** *See* Log turner; Steam nigger.

**Steam nigger.** A long-toothed lever arm, actuated by steam pistons, which is used to turn logs on a sawmill carriage. (Gen.) *See* Friction nigger.

Syn.: nigger, steam log turner, log turner.

**Stepping, n.** 1. Lumber worked to a size and pattern suitable for steps.

2. An export grade of southern yellow pine and Douglas fir.

**Stick, v.** To place lumber in a pile with stickers separating each course of lumber. (Gen.)

Syn.: pile, stack, strip.

**Sticker, n.** 1. A piece of lumber which separates the different courses of lumber in a pile. (Gen.)

Syn.: gobb, (E. C.), piling strip, strip.

2. A machine used in a sash, door, and blind factory for shaping door and sash rails and stiles, sash bars, and muntins. (Gen.)

**Stock boards.** Boards of even widths, usually in widths of 8, 10, and 12 inches. (Gen.)

**Stock logs, to.** To deliver logs from stump to mill or railroad. (S. F.)

**Stock widths.** Lumber cut in even widths from 4 to 12 inches. (Gen.)

**Storage boom.** A strong boom used to hold logs in storage at a sawmill, booming grounds, or wherever necessary. (Gen.)

Syn.: holding boom, receiving boom.

**Straight grain.** The wood of a tree or log is said to be straight grained when the principal wood cells are parallel to the axis of growth. A piece of lumber is said to be straight grained when the principal wood cells are parallel to its length.

**Straw boss, n.** A sub-foreman in a sawmill or a sawmill yard. (P. C. F.)

**String Measure.** *See* Hoppus String Measure; Liverpool String Measure.

**Strip, n.** 1. A narrow 1-inch board. (Gen.)

2. *See* Sticker.

**Strip, v.** *See* Stick.

**Strip catcher, n.** *See* Edger tailer.

**Strip count.** In surfaced lumber, a tally of pieces according to the width and length of the rough material from which the finished product was made. (Gen.)  
*See* Face count.

**Strips.** *See* Edgings.

**Stud, n.** *See* Scantling.

**Studding, n.** *See* Scantling.

**Superficial foot.** (S. F.) *See* Surface measure.

**Surface, v.** To plane one or more sides of a board, plank, timber, or other sawed material. (Gen.)  
Syn.: dress, plane.

**Surface Measure (S. M.).** The area in square feet on one face of a board. When the boards are 1 inch in thickness the term is synonymous with board feet. (Gen.)

Syn.: face measure, superficial foot.

**Surfacer, n.** A general term for a machine which surfaces lumber. (Gen.)

**S I S I E.** A term used to designate lumber which has been surfaced on one side and one edge. The same system is used to designate lumber which has been surfaced on a greater number of sides; e.g., S 4 S designates a board surfaced on four sides. (Gen.)

**S 4 S C S.** Surfaced four sides with a calking seam on each edge. (P. C. F.)

**Survey, v.** *See* Grade.

**Surveyor, n.** 1. A State official who inspects and tallies cargo lots of lumber. (Gen.)  
2. *See* Marker.

**Swage, n.** A tool used to spread the points of teeth of a band or circular rip saw. (Gen.)

Syn.: jumper, upset.

**Swage a saw, to.** To spread the ends of the teeth of a band or circular rip saw. (Gen.)

Syn.: square dress, to.

**Swage set.** A saw is swage set when the ends of the teeth are spread to a width greater than the thickness of the saw. Head-saws and nearly all rip saws are swage set. (Gen.)

Syn.: square dress.

**Swamper, n.** *See* Off-bearer.

**SwEEP, n.** The natural crook in a log. (Gen.)

**Swing saw.** A circular cut-off saw the frame of which is suspended on a shaft either above or below the cutting line. The saw is pulled forward to make a cut and when released automatically retires from the saw cut. (Gen.)

**Swing-up saw.** A circular cut-off saw the frame of which is hung on a shaft below the cutting line. The saw is swung up out of its housing when in use. Chiefly used to cut large timbers. (Gen.)

**Tail edger.** *See* Edger tailer.

**Tail sawyer.** *See* Log roller; Off-bearer.

**Take-away man.** *See* Off-bearer.

**Tally, n.** A record of the number of pieces and the grades of lumber. (Gen.)

- Tallyman, n.** One who records on a tally sheet the number and grade of the pieces of lumber as they leave the sawmill. (Gen.) *See* Checker.
- Tally sheet.** A card or sheet of paper on which is recorded the number of pieces and the grades of lumber. (Gen.)  
Syn.: tally card.
- T. and G.** Tongued and grooved. (Gen.)
- Taper set lever.** A lever attached to the knee of a sawmill carriage head block by means of which any knee may be placed out of alignment. It is of service when making the first cuts on swell-butted logs. (Gen.)
- Tap line.** A chartered logging railroad which shares with the trunk-line railroads in a division of the through lumber rate to market on products originating at the plant of the owner of the logging railroad. (S. F.)
- T. B. and S.** In box shook manufacture, top, bottom and sides. (Gen.)
- Tension, v.** To make a circular or a band saw more loose in the center than on the cutting edge.  
Syn.: open.
- Three-ply veneer.** A piece of built-up veneer composed of three pieces glued one to the other. *See* Laminated wood.
- Throat, n.** On a saw, the rounded cavity in which sawdust accumulates and is carried from the cut. (Gen.)  
Syn.: chamber, gullet.
- Tie man, n.** At a sawmill plant, one who ties surfaced lumber, laths, or other products into bundles. (Gen.)  
*See* Lath bundler. (Gen.)
- Tight cooperage.** Packages, consisting of two round heads and a body composed of numerous staves held together with hoops, which are used as containers for liquids. (Gen.)
- Tight knot.** *See* Standard knot.
- Timber, n.** 1. Sawed material, 4 by 4 inches or more in dimension. (Gen.)  
2. Sawed material more than  $4\frac{1}{2}$  inches in thickness and more than 6 inches in width. (English markets.)
- Timber mill.** 1. A sawmill which specializes on heavy timbers. (Gen.)  
2. In a sawmill, the sawing rig used for cutting timbers. (Gen.)
- Timber planer.** *See* Sizer.
- Timber roller.** *See* Dolly.
- Tire, n.** That part of a band saw blade, extending an inch or so back from the saw edges, which has not been stretched to conform to the segment to which the balance of the blade is tensioned. This leaves the saw tighter at the tire than it is in the middle. The width of the tire varies with the width of the saw blade and the amount of tension carried. (Gen.)
- Ton, n.** In reference to European timber measurement, 480 feet, board measure.
- Top saw.** The upper of two circular saws on a head-saw, both hung on the same husk. Circular mills frequently do not have a top saw. (Gen.)  
Syn.: overhead saw.
- Top-sawyer, n.** One who stands above the log and aids in operating a whip-saw, (Gen.)



- Torn grain.** A machine defect on surfaced lumber, the fibers of the wood having been torn out around knots and curly places by the action of the planer knives. It is classified as slight,  $\frac{1}{32}$  inch deep; medium,  $\frac{1}{16}$  inch deep; heavy,  $\frac{1}{8}$  inch deep; and deep, more than  $\frac{1}{8}$  inch. (Gen.)
- Train, n.** In fluming lumber, a number of bundles of lumber tied together end to end. (Cal.)
- Tram, v.** To transport lumber from the sawmill to the drying yard. *See* Distribute lumber, to.
- Transit car.** A shipment of lumber leaving the mill either unsold or with final destination not determined. (Gen.)
- Tray shakes.** Shakes that are used as bottoms for trays in drying fruit. They are usually 24 inches long, 6 inches wide, and  $\frac{1}{4}$  inch thick on the thinner edge. (Cal.)
- Trim, n.** *See* Interior trim.
- Trim, v.** To make square the ends of boards and timbers. (Gen.)  
Syn.: butt, clip, end butt, equalize.
- Trimmer, n.** A battery of cut-off saws, either suspended from above the trimmer table or hung beneath it, which is used to trim the ends of lumber to even lengths. (Gen.) *See* Overhead trimmer.  
Syn.: equalizer.
- Trimmer feeder.** *See* Trimmer loader.
- Trimmer leverman.** One who operates the levers by means of which the trimmer saws are raised and lowered. (Gen.)  
Syn.: trimmer man.
- Trimmer loader.** One who stands at the trimmer and places the lumber in position on the table in front of the trimmer saws. (Gen.)  
Syn.: trimmer feeder (P. C. F.), trimmer setter.
- Trimmer man.** *See* Trimmer leverman.
- Trimmer setter.** *See* Trimmer loader.
- Trip.** *See* Lumber transfer.
- Tripper, n.** One who, by means of mechanical or other devices, diverts lumber from live rollers behind the saw to the edger or to some other machine. (Gen.)  
Syn.: pointer (Cal.), edger helper, tripper man. (Gen.)
- Tripper man.** *See* Tripper.
- Trolley, n.** A small iron-wheeled car running on a wooden track, which hauls lumber from a portable sawmill to the storage yard. (N. F.)  
Syn.: buggy.
- Trucker, n.** One who handles rough lumber from the dry sheds or yards to the planing mill. (Gen.)
- Twin band mill.** A mill which has both a right-hand and a left-hand saw used to slab logs or to rip cants. Both saws may be mounted on the same frame or they may be mounted on separate movable frames, so that the distance between saw may be altered. (Gen.)
- Twin feed.** A twin-cylinder engine used to actuate the ropes driving a sawmill carriage having a cable feed. (Gen.)

- Undercut trimmer.** A trimmer, the saws of which are hung below the trimmer table, cutting from the underside of the board. (Gen.)
- Underweights.** The difference between the association standard and the actual rail shipping weights of shingles and lumber. Products are sold on the association standard shipping weights. By kiln-drying, shippers are able to reduce the actual shipping weight below the standard and thus profit by the difference in the freight charges. (Gen.)
- U/S. (Unsorted.)** A term used in European lumber trade quotations.
- Unstacker.** One who removes dry lumber from dry-kiln trucks. (Gen.)
- Uppers, n.** *See* Finish.
- Upset, n.** *See* Swage.
- Veneer, n.** A thin piece of lumber cut on a veneer machine. There are three kinds of veneers, namely, sawed, sliced, and rotary cut. (Gen.)
- Vertical band resaw.** *See* Horizontal band resaw.
- Vertical-grained.** *See* Quarter-sawed.
- Wagon box boards.** Lumber used in the manufacture of wagon boxes. (Gen.)  
Syn.: box boards.
- Wane, n.** Bark or the lack of bark or a decrease in wood from any cause on the edges of a board, plank, or timber. (Gen.)
- Waney lumber.** Lumber which is not square edged.
- Washboard, v.** A term used to denote the action of a saw or a planing machine head which makes ridges on lumber. (Gen.)
- Waste, n.** That portion of the log having a merchantable value which is not utilized. Sawdust and refuse used for fuel, and those portions of logs, slabs, edgings, and trimmings used for laths, shingles, cooperage, and other products are not waste. (Gen.)
- Water stain.** Streaks or patches of red or brown discoloration in firm wood of hemlock.
- Water streak.** A dark streak in oak lumber due to injury to the standing timber. (App.)
- Wavy grain.** *See* Curly grain.
- Weather board.** *See* Bevel siding; Siding.
- Wet mill.** A sawmill at which logs are stored in water. (Gen.)
- Whip-saw, n.** A saw, operated by two men, which is used to cut logs into lumber. (Gen.)  
Syn.: pit saw.
- Whip-saw, v.** To cut lumber with a whip-saw. (Gen.)
- White cypress.** A term used by lumber manufacturers to denote cypress lumber which is light in color. (S. F.)
- Wholesale lumber dealer.** One who buys lumber outright and takes all profits from sales.
- Wire a car, to.** In loading a flat car, to fasten together opposite car stakes with wire. (Gen.)

**Wobble saw.** A thin circular saw of small diameter firmly set at an angle on a mandrel and used to cut grooves in wood. Its object is to remove a wide kerf and obviate the necessity of using several saws. Largely becoming obsolete, due to the development of the dado-head saw. (Gen.)

**Wood fiber.** A substitute for hair in plaster, consisting of narrow shavings cut from a round block of wood by means of a special machine. (Gen.)

**Wood-wool, n.** Fine shavings made from wood and used as a substitute for hair in plaster and when made from pine and specially prepared sometimes used as a surgical dressing. (Gen.)

**Worm roller.** *See* Screw rollers.

**Yankee gang mill.** An early and obsolete type of gang mill in which the sash consisted of two parts, one holding saws for removing slabs, and the other having saws designed to cut cants into lumber. The two processes were carried on simultaneously, the log passing through one side of the sash from the front and a cant returning through the opposite side of the sash from the rear.

**Yard lumber.** Lumber which has been air-dried in a yard. A term often applied collectively to those grades of lumber usually air-dried. (Gen.)

## LUMBER GRADES

TABLE XVI.—LUMBER GRADES PRODUCED FROM SOUTHERN  
YELLOW PINE

Florida and Georgia		Arkansas	
Lumber Grade	Per Cent *	Lumber Grade	Per Cent †
Prime.....	17	B. and better.....	25.8
Merchantable.....	49	No. 1 common.....	22.6
Sound and square-edged.....	20	No. 2 common.....	39.5
No. 1 common.....	13	No. 3 common.....	11.8
No. 2 common.....	1	No. 4 common.....	0.3

\* Average based on the cut of 38 mills.

† Based on a 12-months' cut of approximately 60,000,000 board feet.

TABLE XVII.—LUMBER GRADES PRODUCED FROM WESTERN  
YELLOW PINE (CALIFORNIA)\*

Lumber Grades. Mill No. 1	Grade I Logs. Per Cent	Grade II Logs. Per Cent	Grade III Logs. Per Cent	All Logs. Per Cent
Nos. 1 and 2 clear.....	29.5	5.4	0.6	8.8
No. 3 clear.....	10.6	4.0	0.6	4.1
C. select.....	0.9	0.7	0.3	0.6
Australian.....	6.9	1.9	0.3	2.4
No. 1 shop.....	11.1	12.9	2.5	8.3
No. 2 shop.....	10.3	23.8	6.5	13.8
No. 3 shop.....	2.3	6.2	3.9	4.4
Nos. 1 and 2 common.....	12.8	24.1	48.0	31.2
Box.....	15.1	20.5	36.1	25.6
No. 3 common.....	0.5	0.5	1.2	0.8

\* Data from A Study of the Grades of Lumber Produced from California Pine, Fir and Cedar, by Swift S. Berry, The Timberman, March, 1918, pages 36 and 37, and April, 1918, pages 39 and 40.

TABLE XVIII.—LUMBER GRADES PRODUCED FROM WESTERN YELLOW PINE (WASHINGTON AND OREGON)\*

Lumber Grades	Per Cent
B. select and better.....	1.47
C. and D. select.....	7.22
Nos. 1 and 2 shop.....	13.63
No. 1 common.....	6.44
No. 2 common.....	14.61
Nos. 3 and 4 common.....	29.36
Yellow box.....	27.27

\* Based on 62.3 per cent of the total cut on the East side of the Cascade Mountains. See Character and Distribution of 1920 Lumber and Shingle Cut, by C. W. Gould, West Coast Lumberman, May 15, 1921.

TABLE XIX.—LUMBER GRADES PRODUCED FROM SUGAR PINE \*

Lumber Grades. Mill No. 1	Grade I † Logs. Per Cent	Grade II Logs. Per Cent	Grade III Logs. Per Cent	All Logs. Per Cent
Nos. 1 and 2 clear.....	32.3	5.8	0.7	8.3
No. 3 clear.....	11.2	4.3	0.4	3.8
C. select.....	2.1	0.8	0.2	0.8
Australian.....	2.3	1.0	.....	0.5
No. 1 shop.....	12.5	11.4	1.3	7.2
No. 2 shop.....	10.6	19.3	3.7	10.9
No. 3 shop.....	1.7	9.1	4.6	5.8
Nos. 1 and 2 common.....	8.7	22.1	52.0	31.3
Box.....	17.3	25.1	35.7	30.0
No. 3 common.....	1.3	1.1	1.4	1.4

\* Band-sawed lumber. Data from A Study of the Grades of Lumber Produced from California Pine, Fir and Cedar.

† The specifications for the various grades of logs are those adopted by the U. S. Forest Service for all log grading work in California. They may be found in the reference above mentioned.

TABLE XX.—LUMBER GRADES PRODUCED FROM DOUGLAS FIR (WASHINGTON AND OREGON)\*

Lumber Grades	Per Cent
No. 2 clear and better.....	22.40
No. 1 select common boards and shiplap.....	17.78
No. 1 common dimension.....	24.49
Timbers.....	16.34
No. 2 common.....	10.45
Cross ties.....	8.54

\* From Report on Character and Distribution of 1920 Lumber and Shingle Cut, by C. W. Gould, West Coast Lumberman, May 15, 1921, page 32. Data based on 72.7 per cent of the total cut of Douglas fir on the West side of the Cascade Mountains.

TABLE XXI.—LUMBER GRADES PRODUCED FROM DOUGLAS FIR  
(CALIFORNIA)\*

Lumber Grades. Mill No. 1	Grade I Logs. Per Cent	Grade II Logs. Per Cent	Grade III Logs. Per Cent	All Logs. Per Cent
Clear and select.....	35.0	6.3	1.2	10.1
Nos. 1 and 2 common.....	55.4	84.8	88.0	80.0
No. 3 common.....	9.6	8.9	10.8	9.9

\* Data from A Study of the Grades of Lumber produced from California, Fir and Cedar.

TABLE XXII.—AVERAGE LUMBER GRADES PRODUCED FROM  
EASTERN HEMLOCK \*

Lumber Grades	Per
No. 1 common.....	44
No. 2 common.....	33
No. 3 common.....	23

\* Data from The Northern Hemlock and Hardwood Manufacturers' Association, St. Louis Lumberman, Dec. 1, 1914, page 64.

TABLE XXIII.—LUMBER GRADES PRODUCED FROM RED FIR \* †

Lumber Grades. Mill No. 5	Grade I Logs. Per Cent	Grade II Logs. Per Cent	All Logs. Per Cent
Clear and select.....	28.5	3.6	5.7
Nos. 1 and 2 common.....	50.9	82.7	80.1
No. 3 common.....	20.6	13.7	14.2

\* *Abies magnifica.*

† Data from A Study of the Grades of Lumber Produced from California Pine, Fir and Cedar.

TABLE XXIV.—LUMBER GRADES PRODUCED FROM WHITE FIR \*

Lumber Grades. Mill No. 1	Grade I Logs. Per Cent	Grade II Logs. Per Cent	All Logs. Per Cent
Clear and select.....	17.1	0.5	0.8
Nos. 1 and 2 common.....	50.6	60.6	57.9
No. 3 common.....	32.3	38.9	41.3

\* Data from A Study of the Grades of Lumber Produced from California Pine, Fir and Cedar.

TABLE XXV.—LUMBER GRADES PRODUCED FROM INCENSE CEDAR \*

Lumber Grades	All Logs	
	Mill No. 1. Per Cent	Mill No. 2. Per Cent
Clear and select.....	.....	1.5
Nos. 1 and 2 common.....	99.4	69.9
No. 3 common.....	0.6	28.6

\* Data from A Study of the Grades of Lumber Produced from California Pine, Fir and Cedar.

TABLE XXVI.—LUMBER GRADES PRODUCED IN THE INLAND EMPIRE \*

Lumber Grades	Species					
	Idaho White Pine. Per Cent	Western Yellow Pine. Per Cent	Western Larch. Per Cent	Douglas Fir. Per Cent	White Fir. Per Cent	Western Red Cedar. Per Cent
Select.....	14	10.0	3.0	3.0	.....	3
Shop.....	2	22.0				
No. 1 common.....	12	0.4	3.0	3.0	.....	97‡
No. 2 common.....	29	19.0				
No. 3 common.....	26	39.0	14.0	14.0	92†	
No. 4 common.....	12	8.0	4.0	4.0	8	
No. 5 common.....	2	0.3				
Miscellaneous.....	3	1.0	76.0	76.0		

\* Data from Timber Ownership and Lumber Production in the Inland Empire, by D. T. Mason, published by The Western Pine Manufacturers' Association, Portland, Oregon, 1920.

† Includes No. 3 common and better.

‡ Includes all grades of common produced.

TABLE XXVII.—YIELD OF LUMBER BY GRADES FROM OAK LOGS \*

Basis, No. of Logs	Doyle Scale		Net Lumber Tally												Overrun Lumber Tally Over Doyle Scale	Time to Saw Log.	Feet, B. M. Produced per Hour		
	Full.	Net.	Per Cent of Each Grade						Common									Full.	Net.
			Firsts and Seconds		No. 1		No. 2		No. 3		Quar-tered.	Plain.	Quar-tered.	Plain.					
			Plain.	Quar-tered.	Plain.	Quar-tered.	Plain.	Quar-tered.	Plain.	Quar-tered.									
Feet	Feet	Feet, B. M.	Per Cent	Per Cent	Per Cent	Per Cent	Per Cent	Per Cent	Per Cent	Per Cent	Per Cent	Per Cent	Per Cent	Per Cent	Per Cent	Seconds			
WHITE OAK																			
3	15	121	187	2.75	.....	31.75	.....	29.00	0.50	36.00	+54.5	+54.5	202	3333					
1	16	144	205	3.50	.....	33.75	.....	26.00	0.75	36.00	+42.4	+42.4	221	3339					
11	17	169	227	3.75	.....	34.50	2.50	23.25	1.00	35.00	+34.3	+37.6	243	3363					
8	18	196	245	4.25	0.50	35.00	4.00	21.00	1.50	33.75	+25.0	+26.3	269	3280					
15	19	225	268	4.50	0.50	34.50	6.50	19.00	2.50	32.50	+19.1	+19.1	297	3248					
8	20	256	248	4.50	1.00	33.00	10.00	17.00	3.50	31.00	+11.3	+14.9	330	3109					
9	21	289	305	4.50	1.50	31.00	15.00	14.50	5.00	28.50	+5.5	+5.5	370	2967					
17	22	324	328	4.00	2.50	28.50	21.50	12.50	6.50	24.50	+1.2	+2.2	414	2852					
12	23	359	351	3.25	4.00	24.75	29.00	10.50	8.00	20.50	-2.2	-2.2	468	2701					
11	24	400	385	3.00	5.50	21.50	34.00	9.00	9.50	17.50	-6.8	-3.1	522	2572					
20	25	441	436	2.00	8.50	17.50	38.00	7.50	11.50	15.00	-10.9	-8.9	580	2464					
11	26	484	479	1.50	10.50	14.00	41.50	6.50	13.00	13.00	-12.4	-11.5	639	2389					
12	27	530	522	1.50	12.50	10.50	44.50	5.50	14.00	11.50	-14.9	-13.6	700	2319					
3	28	576	569	1.25	14.00	8.75	47.00	4.50	14.50	10.00	-16.5	-15.5	761	2275					
7	29	625	620	1.25	15.00	6.50	49.00	3.50	14.50	9.25	-18.2	-17.6	829	2219					
6	30	676	670	1.25	16.00	6.50	51.00	2.50	14.00	8.75	-19.5	-18.8	893	2193					
4	31	729	713	1.00	16.75	6.50	52.00	2.00	13.25	8.50	-20.5	-18.7	961	2173					
1	32	784	743	1.00	17.00	6.50	53.00	1.50	12.50	8.50	-21.6	-17.2	1027	2156					
1	33	841	841	1.00	17.50	6.00	54.00	1.50	11.50	8.50	-22.9	-22.9	1098	2124					



LUMBER GRADES

RED OAK

4	15	121	121	155	6.50	29.50	22.00	42.00	+28.1	+28.1	191	2921
2	16	144	144	189	7.00	30.75	22.00	40.25	+31.2	+31.2	206	3303
5	17	169	163	224	7.50	31.50	0.25	38.50	+32.5	+37.4	214	3769
7	18	196	185	257	8.00	33.00	0.25	36.50	+31.1	+38.9	243	3807
14	19	225	222	283	8.75	34.00	0.25	35.00	+25.8	+27.5	264	3859
8	20	256	250	325	9.75	35.00	0.25	33.25	+27.0	+30.0	287	4077
6	21	289	268	360	10.75	36.00	0.25	31.50	+24.6	+34.3	310	4181
6	22	324	320	393	11.50	36.75	0.50	30.00	+21.3	+22.8	334	4237
15	23	359	354	430	12.50	37.25	0.75	28.50	+19.8	+21.5	361	4288
7	24	400	393	464	13.50	37.50	1.00	27.00	+16.0	+18.1	389	4294
6	25	441	426	500	14.25	37.50	1.50	25.50	+13.4	+17.4	415	4338
7	26	484	451	535	15.00	37.50	2.00	24.25	+10.5	+18.6	442	4357
4	27	530	512	570	15.50	37.50	2.50	22.50	+7.5	+11.3	472	4347
7	28	576	549	605	16.25	37.00	3.00	21.25	+5.0	+10.2	502	4339
8	29	625	613	640	16.75	36.50	3.75	20.00	+2.4	+4.4	537	4290
7	30	676	643	674	17.25	35.75	4.50	19.00	-0.3	+4.8	575	4219
4	31	729	678	709	17.75	34.50	5.25	18.00	-2.7	+4.6	613	4164
1	32	784	784	742	18.25	33.25	6.00	17.00	-5.4	-5.4	650	4109
5	33	841	834	778	18.50	31.75	6.75	16.00	-7.5	-6.7	690	4059
..	34	900	900	816	19.00	30.25	7.50	15.25	-9.3	-9.3	732	4013
2	35	961	961	853	19.25	29.25	8.00	14.75	-11.2	-11.2	775	3962
..	36	1024	1024	896	19.50	27.75	8.75	14.00	-12.5	-12.5	820	3934
1	37	1089	1089	939	19.50	27.00	9.25	13.50	-13.8	-13.8	870	3888
1	38	1156	1156	983	19.75	26.25	9.50	13.00	-15.0	-15.0	915	3867
1	39	1225	1158	1032	19.75	25.25	10.00	12.50	-15.8	-10.9	970	3830
..	40	1296	1296	1083	20.00	25.50	10.50	12.00	-16.4	-16.4	1020	3822
1	41	1369	1369	1135	20.00	25.00	10.75	11.50	-17.1	-17.1	1070	3819
..	42	1444	1444	1187	20.00	24.00	11.25	11.25	-17.8	-17.8	1119	3819
..	43	1521	1521	1244	20.25	23.00	11.50	10.50	-18.2	-18.2	1170	3828
2	44	1600	1580	1300	20.25	22.00	11.75	10.00	-18.7	-17.7	1220	3836
2	45	1681	1562	1360	20.50	21.00	12.25	9.75	-19.1	-12.9	1270	3858

\* From The Manufacture and Seasoning of Oak, by D. G. White, Hardwood Record, Aug. 25, 1921, pages 18 to 20.

TABLE XXVIII.—AVERAGE LUMBER GRADES PRODUCED FROM NORTHERN HARDWOODS \*

Species	Grades			
	F. A. S. Per Cent	No. 1 Common. Per Cent	No. 2 Common. Per Cent	No. 3 Common. Per Cent
Ash.....	17	27	23	33
Basswood.....	19	29	25	27
Birch.....	20	28	21	31
Elm, rock.....	18	27	23	32
Elm, soft.....	15	25	24	36
Maple, hard.....	14	30	22	34
Maple, soft.....	18	30	22	30
Oak.....	18	27	23	32

\* Data from The Northern Hemlock and Hardwood Manufacturers' Association, St. Louis Lumberman, Dec. 1, 1914, page 64.

TABLE XXIX.—LUMBER GRADES PRODUCED FROM SOUTHERN OAK \*

Lumber Grades	Per Cent
F. A. S. plain.....	20
No. 1 common, plain.....	30
No. 2 common, plain.....	36
No. 3 common, plain.....	14

\* From the Hardwood Record, Feb. 10, 1915, page 43.

TABLE XXX.—AVERAGE LUMBER GRADES PRODUCED FROM RED GUM \*

Lumber Grades	Logs 12 to 18 Inches Diameter, Average 16 Inches. Per Cent	Logs 17 to 20 Inches Diameter, Average 18.7 Inches. Per Cent	Logs 21 to 26 Inches Diameter, Average 22.6 Inches. Per Cent	Logs 26 Inches and up in Diameter, Average 30.4 Inches. Per Cent	Logs 12 to 36 Inches Diameter, Average 21.9 Inches. Per Cent
F. A. S., red. . . . .	2.19	1.14	5.03	20.42	7.19
No. 1 common, red. . . . .	5.64	8.92	14.52	10.21	9.83
Box boards. . . . .	2.87	1.47	5.83	8.87	4.76
F. A. S., sap. . . . .	11.43	26.60	38.35	37.92	28.57
No. 1 common, sap. . . . .	25.42	23.57	15.35	6.97	17.83
No. 2 common, sap. . . . .	33.17	24.37	11.12	8.90	19.39
No. 3 common, sap. . . . .	19.28	13.93	9.80	6.71	12.43

\* Based on a study made at a band mill in Mississippi. See American Lumberman, Sept. 25, 1915, page 34.

TABLE XXXI.—LUMBER GRADES PRODUCED FROM 16-FOOT  
MAPLE LOGS \*

Logs			Net Lumber Tally by Grades (From Curves)					Overrun.	Waste † in Log.
No.	Top Diam- eter, Inside Bark. Inches	Doyle Scale.  Feet	F. and S.  Bd. Ft.	No. 1 Com- mon.  Bd. Ft.	No. 2 Com- mon.  Bd. Ft.	No. 3 Com- mon.  Bd. Ft.	Total.  Bd. Ft.		
1	9	25	.....	2.2	7.2	40.1	49.5	98.0	24.5
2	11	49	.....	6.7	14.6	57.7	79.0	61.2	30.1
3	12	64	.....	12.1	19.8	64.6	96.5	50.8	40.4
13	13	81	2.9	21.5	24.9	66.7	116.0	43.2	38.8
14	14	100	9.9	33.9	28.8	64.4	137.0	37.0	39.9
10	15	121	19.6	4.6	31.6	62.4	160.0	32.2	37.4
3	16	144	31.3	57.5	32.6	62.6	184.0	27.8	36.2
4	17	169	43.2	68.4	33.7	65.2	210.5	24.5	36.2

\* From A Mill Scale Study of Maple, by David G. White, Hardwood Record, Feb. 10, 1917, pages 41a to 41f, inclusive.

† Waste per cent includes "scoots," but does not include waste due to extra inches over the even 16-foot log.

## AVERAGE WEIGHTS OF WOODS

† TABLE XXXII.—AVERAGE WEIGHTS OF WOOD \*

Species	Locality	Weights per Cubic Foot †		
		Green. ‡ Pounds	Air-dry. § Pounds	Kiln-dry.    Pounds
<b>HARDWOODS:</b>				
Ash, black.....	Michigan	53	36	34
Ash, blue.....	Kentucky	46	41	39
Ash, green.....	Missouri	49	42	40
Ash, white.....	Arkansas	47	42	41
Aspen, largetooth.....	Wisconsin	43	27	26
Basswood.....	Wisconsin	41	25	24
Beech.....	Pennsylvania	54	43	41
Birch, paper.....	Wisconsin	58	37	31
Birch, sweet.....	Pennsylvania	59	47	45
Birch, yellow.....	Wisconsin	59	44	43
Buckeye.....	Tennessee	49	25	24
Butternut.....	Tennessee	47	28	27
Cherry.....	Pennsylvania	46	36	34
Chestnut.....	Tennessee	56	30	29
Cottonwood.....	Wisconsin	49	29	28
Cucumber.....	Tennessee	50	34	33
Elm, cork.....	Wisconsin	53	44	43
Elm, slippery.....	Indiana	53	43	42
Elm, white.....	Pennsylvania	53	35	35
Gum, black.....	Tennessee	45	36	35
Gum, red.....	Missouri	46	35	
Hickory, shellbark.....	Mississippi	62	49	47
Hickory, shagbark.....	Mississippi	63	49	47
Locust, black.....	Tennessee	58	49	48
Maple, hard.....	Pennsylvania	54	43	41
Maple, red.....	Wisconsin	54	38	37
Oak, bur.....	Wisconsin	61	45	43
Oak, red.....	Arkansas	65	45	43
Oak, white.....	Arkansas	59	48	46
Oak, white.....	Louisiana	63	47	46
Poplar, yellow.....	Tennessee	38	28	27
Sycamore.....	Tennessee	53	36	25
Tupelo.....	Louisiana	66	37	35
Walnut, black.....	Kentucky	58	44	41

TABLE XXXII.—AVERAGE WEIGHTS OF WOOD.\*—*Continued*

Species	Locality	Weights per Cubic Foot †		
		Green. ‡ Pounds	Air-dry § Pounds	Kiln-dry.    Pounds
CONIFERS:				
Cedar, Port Orford . . . . .	Washington	39	31	30
Cedar, western red . . . . .	Washington	30	24	23
Cedar, white . . . . .	Wisconsin	28	21	21
Cypress, bald . . . . .	Louisiana	51	34	33
Douglas fir . . . . .	Washington	41	37	35
Fir, balsam . . . . .	Wisconsin	45	25	24
Hemlock . . . . .	Wisconsin	49	25	24
Hemlock, western . . . . .	Washington	40	31	30
Larch, western . . . . .	Montana	51	39	37
Pine, loblolly . . . . .	Florida	54	39	37
Pine, lodgepole . . . . .	Montana	47	28	27
Pine, longleaf . . . . .	Louisiana	54	41	39
Pine, Norway . . . . .	Wisconsin	42	34	32
Pine, shortleaf . . . . .	Arkansas	45	36	35
Pine, sugar . . . . .	California	50	27	26
Pine, western white . . . . .	Montana	39	30	29
Pine, western yellow . . . . .	Arizona	44	26	25
Pine, white . . . . .	Wisconsin	39	27	26
Spruce, Englemann . . . . .	Colorado	48	23	22
Spruce, red . . . . .	New Hampshire	32	29	28
Spruce, white . . . . .	New Hampshire	28	26	25
Tamarack . . . . .	Wisconsin	47	38	37

\* Data from *The Seasoning of Wood*, by H. S. Betts, U. S. Dept. of Agriculture, Bulletin No. 552, Washington, 1917.

† Any individual lot of lumber may vary 5 per cent from the figures given, with a possible variation of 20 per cent.

‡ Average green material.

§ 12 to 15 per cent moisture content.

|| About 8 per cent moisture content.

# ESTIMATED WEIGHTS OF LUMBER

## TABLE XXXIII.—STANDARD ESTIMATED WEIGHTS OF LUMBER <sup>1</sup>

Species	Weight per 1000 Feet, Board Measure			
	Green. Pounds	Shipping Dry. Pounds	Well Seasoned. Pounds	Kiln Dried. Pounds
<b>HARDWOODS:</b>				
Ash, black.....	4600	.....	3200	3000
Ash, white.....	4600	.....	3800	3300
Basswood.....	4200	2800	2500	2100
Beech.....	5750	.....	4000	
Birch.....	5500	.....	4000	
Butternut.....	4000	.....	2500	
Cherry.....	5000	.....	3800 <sup>2</sup>	
Chestnut.....	5000	.....	2800	2450
Cottonwood.....	4600	3100	2800	2400
Elm, rock.....	5400	4300	4000	3500
Elm, soft.....	4750	3300	3100	2900
Gum, red.....	5400	3600	3300	3050
Gum, sap.....	5000	3300	3000	2750
Hackberry.....	4600	.....	3200	
Hickory.....	6000	.....	4500	
Locust.....	4800	.....	3500	
Maple, hard.....	5400	4150	3900	3400
Maple, soft.....	5000	3650	3300	3000
Oak, red.....	5500	4250	4000	3400
Oak, white.....	5700	4500	4100	3600
Poplar.....	3900	3000	2800	2400
Poplar, bay <sup>3</sup> .....	5000	.....	3000	
Sycamore.....	4750	.....	3000	
Walnut.....	4900	4000	3800	
Willow.....	4200	.....	2800	
<b>SOFTWOODS:</b>				
Cedar, western red <sup>4</sup> .....	3000	2700		
Cypress 4/4 <sup>3</sup> .....	5000	.....	3000	
Fir, Douglas, 4/4 <sup>4</sup> .....	3500	3000		2900
Hemlock, eastern (Pa.).....	4000	.....	2500	
Hemlock, western <sup>4</sup> .....	4000	2900	2500	
Larch, western <sup>6</sup> .....	.....	2700 <sup>15</sup>		
Pine, eastern white.....	4000 <sup>5</sup>	2500	2400 <sup>5</sup>	2200
Pine, Idaho white.....	4000	2900	2500	
Pine, longleaf <sup>7</sup> .....	4500 <sup>14</sup>	3500		3400
Pine, North Carolina <sup>8</sup> .....	.....	3100		
Pine, Norway <sup>5</sup> .....	4000	.....	2400	
Pine, short leaf <sup>7</sup> .....	4200 <sup>14</sup>	3400		3200
Pine, sugar <sup>9</sup> .....	.....	2600 <sup>10</sup>	2220 <sup>12</sup>	
Pine, western white <sup>12</sup> .....	5000	2500-2600	2220	
Pine, western yellow <sup>11</sup> .....	3500-3700		2400	
Redwood <sup>13</sup> .....		2400		
Spruce, Adirondack.....	3300	2700	2300	
Spruce, West Virginia.....	3000	2700	2300	2200

<sup>1</sup> Unless otherwise stated the weights quoted are those adopted by the National Wholesale Lumber Dealers' Association. <sup>2</sup> National Hardwood Lumber Association. <sup>3</sup> The Southern Cypress Manufacturers' Association. <sup>4</sup> West Coast Lumbermen's Association. <sup>5</sup> Northern Pine Manufacturers' Association. <sup>6</sup> Western Pine Manufacturers' Association. <sup>7</sup> The Southern Pine Association. <sup>8</sup> North Carolina Pine Association. <sup>9</sup> Bull. No. 440, U. S. Dept. of Agriculture. <sup>10</sup> The California White and Sugar Pine Manufacturers' Association. <sup>11</sup> Bull. No. 418, U. S. Dept. of Agriculture. <sup>12</sup> Data submitted to the Interstate Commerce Commission, Feb. 10, 1914. <sup>13</sup> Redwood Manufacturers' Association. <sup>14</sup> Timbers. <sup>15</sup> Two-inch dimension, rough. This represents a combination of air-dried and kiln-dried weights.

# STANDARD WEIGHTS OF HARDWOOD LUMBER

## TABLE XXXIV.—OFFICIAL STANDARD WEIGHTS OF HARDWOOD LUMBER \*

Species	Thick- ness.	Rough Dry. Pounds per 1000	Species	Thick- ness.	Rough Dry. Pounds per 1000	
	Inches	Bd. Ft.		Inches	Bd. Ft.	
Ash.....	3/8	1500	Maple (soft).....	4/4	3250	
	1/2	2000		} 5/4, 6/4	8/4	3350
	5/8	2500			8/4	3500
	3/4	3000			3/8	2000
	4/4	3800			1/2	2200
	5/4, 6/4	3900			5/8	2700
	8/4	4000	Oak, eastern.....	3/4	3200	
Basswood.....	4/4	2600		4/4	3900	
Beech.....	4/4	4000		} 5/4, 6/4	8/4	4200
Birch.....	4/4	4000	Chair and furniture stock.....			4200
Butternut.....	4/4	2800		Squares.....		4200
Buckeye.....	4/4	2600	Wagon stock and felloes.....		4500	
Cherry.....	4/4	4000	Plow handle strips.....		4250	
Chestnut.....	4/4	4800		1/4	1100	
	1/4	1050	Oak, Memphis Terri- tory.....	3/8	1700	
	3/8	1050		1/2	2150	
Cottonwood.....	1/2	1400		} 5/8	5/8	2700
	5/8	1750			3/4	3250
	3/4	2000			4/4	4200
	4/4	2800	} 5/4, 6/4	8/4	4300	
Elm (rock).....	5/4, 6/4	2900		Chair and furniture stock.....		4200
	8/4	3000	Squares.....			4200
Elm (soft).....	4/4	3200	Wagon stock and felloes.....		4500	
	5/4, 6/4	3300	Plow handle strips.....		4250	
Gum, black.....	8/4	3500	} 3/8	3/8	1750	
	10/4, 12/4	3600		1/2	2200	
	4/4	3400		5/8	2750	
	1/4	850		} 3/4	3/4	3400
3/8	1300	4/4	4400			
Gum, red.....	1/2	1750	} 5/4, 6/4	5/4, 6/4	4500	
	5/8	2200		8/4	4800	
	3/4	2700		Pecan.....	4/4	4800
Gum, sap.....	4/4	3500	} 3/8	3/8	1050	
	5/4, 6/4	3600		1/2	1400	
	8/4	3800	} 5/8	5/8	1600	
	1/4	800		3/4	2100	
		3/8	1250	} 4/4	4/4	2800
		1/2	1700		4/4	3200
Hickory.....	5/8	2100	Sycamore.....	4/4	3000	
	3/4	2500	Tupelo.....	} 5/4, 6/4	3100	
	4/4	3300	4/4		4000	
	5/4, 6/4	3400	Walnut.....	8/4	4200	
Axles and reaches.....	8/4	3600	Willow.....	4/4	2800	
Rim strips.....	4/4	5000				
Holly.....	4/4	3500				
Locust.....	4/4	4200				
Magnolia.....	4/4	3500				
Maple, hard.....	4/4	4000				

\* Adopted Feb. 1, 1919, by the American Hardwood Manufacturers' Association.



## STANDARD SIZES OF LUMBER

TABLE XXXV.—SOUTHERN YELLOW PINE \*

Standard Sizes of Manufactured Products Adopted by the Southern Pine Association

Product	Thickness. Inches	Width. Inches	Length.† Feet
Flooring 4/4.....	$\frac{13}{16}$	$2\frac{3}{8}$ , $3\frac{1}{4}$ , $5\frac{1}{4}$ , Face	4 to 20
Flooring 5/4.....	$1\frac{1}{16}$	$3\frac{1}{4}$ , $5\frac{1}{4}$ , Face	4 to 20
Flooring 6/4.....	$1\frac{5}{16}$	$3\frac{1}{4}$ , $5\frac{1}{4}$ , Face	4 to 20
Ceiling.....	$\frac{5}{16}$ , $\frac{7}{16}$ , $\frac{9}{16}$ , $\frac{11}{16}$	$2\frac{1}{4}$ , $2\frac{1}{2}$ , $3\frac{1}{4}$ , $5\frac{1}{4}$ Face	4 to 20
Partition.....	$\frac{3}{4}$	$3\frac{1}{4}$ , $5\frac{1}{4}$ Face	4 to 20
Drop siding, D & M.....	$\frac{3}{4}$	$3\frac{1}{4}$ , $5\frac{1}{4}$ Face	4 to 20
Finish 4/4, S 4 S.....	$\frac{13}{16}$	$3\frac{5}{8}$ , $5\frac{5}{8}$ , $7\frac{1}{2}$ , $9\frac{1}{2}$ , $11\frac{1}{2}$	8 to 20
Finish 5/4, S 4 S.....	$1\frac{1}{16}$	$3\frac{5}{8}$ , $5\frac{5}{8}$ , $7\frac{1}{2}$ , $9\frac{1}{2}$ , $11\frac{1}{2}$	8 to 20
Finish 6/4, S 4 S.....	$1\frac{5}{16}$	$3\frac{5}{8}$ , $5\frac{5}{8}$ , $7\frac{1}{2}$ , $9\frac{1}{2}$ , $11\frac{1}{2}$	8 to 20
Finish 8/4, S 4 S.....	$1\frac{5}{8}$	$3\frac{5}{8}$ , $5\frac{5}{8}$ , $7\frac{1}{2}$ , $9\frac{1}{2}$ , $11\frac{1}{2}$	8 to 20
Shiplap D & M.....	$\frac{3}{4}$	$7\frac{1}{8}$ , $9\frac{1}{8}$ , $11\frac{1}{8}$ Face	4 to 24
Grooved roofing, S 1 S 2 E.....	$\frac{13}{16}$	$9\frac{1}{2}$ , $11\frac{1}{4}$	4 to 24
Molded casing 4/4.....	$\frac{3}{4}$	$3\frac{5}{8}$ , $4\frac{1}{4}$ , $4\frac{3}{4}$ , $5\frac{1}{4}$	
Molded base 4/4.....	$\frac{3}{4}$	$4\frac{1}{4}$ , $5\frac{1}{4}$ , $5\frac{1}{2}$ , $7\frac{1}{4}$	
Common boards 4/4, S 1 S or 2 S.....	$\frac{13}{16}$	$7\frac{3}{4}$ , $9\frac{5}{8}$ , $11\frac{1}{2}$	4 to 24
Common boards 5/4.....	$1\frac{1}{8}$	$7\frac{3}{4}$ , $9\frac{5}{8}$ , $11\frac{1}{2}$	4 to 24
Common boards 6/4.....	$1\frac{3}{8}$	$7\frac{3}{4}$ , $9\frac{5}{8}$ , $11\frac{1}{2}$	4 to 24
Common boards 4/4, S 4 S.....	$\frac{13}{16}$	$7\frac{1}{2}$ , $9\frac{1}{2}$ , $11\frac{1}{2}$	4 to 24
Common boards, D & M.....	$\frac{3}{4}$	$7\frac{1}{8}$ , $9\frac{1}{8}$ , $11\frac{1}{8}$	4 to 24
Common fencing 4/4, S 1 S or 2 S.....	$\frac{13}{16}$	$3\frac{3}{4}$ , $5\frac{1}{4}$	4 to 24
Common fencing, S 2 S & C M.....	$\frac{3}{4}$	$3\frac{1}{4}$ , $5\frac{1}{4}$	4 to 24
Common dimension 8/4, S 1 S 1 E.....	$1\frac{5}{8}$	$3\frac{5}{8}$ , $5\frac{5}{8}$ , $7\frac{1}{2}$ , $9\frac{1}{2}$ , $11\frac{1}{2}$	4 to 24
Common dimension 8/4, S 4 S.....	$1\frac{1}{2}$	$3\frac{1}{2}$ , $5\frac{1}{2}$ , $7\frac{3}{8}$ , $9\frac{3}{8}$ , $11\frac{3}{8}$	4 to 24
Heavy joists 8/4, 10/4, 12/4, S 1 S 1 E.....	$1\frac{3}{4}$ , $2\frac{1}{4}$ , $2\frac{3}{4}$	$9\frac{1}{2}$ , $11\frac{1}{2}$ , $13\frac{1}{2}$	4 to 24
Heavy joists 8/4, 10/4, 12/4, S 4 S.....	$1\frac{1}{2}$ , $2$ , $2\frac{1}{2}$	$9\frac{1}{2}$ , $11\frac{1}{2}$ , $13\frac{1}{2}$	4 to 24
Timbers 4/4 and larger, S 1 S or S and E.....	$\frac{3}{8}$ off of each face surfaced	$\frac{3}{8}$ off of each face surfaced	8 to 20
Timbers 4/4 and larger, S 3 S or S 4 S.....	$\frac{1}{4}$ off of each face surfaced	$\frac{1}{4}$ off of each face surfaced	8 to 20

\* Both shortleaf and longleaf.

† The shorter lengths are permissible up to a specified per cent only.

TABLE XXXVI.—NORTH CAROLINA PINE

Standard Sizes of Manufactured Products Adopted by the North Carolina Pine Association

Kind of Product	Thickness. Inches	Width. Inches	Length.* Feet
Flooring 4/4.....	$\frac{13}{16}$	2½, 3, 3½ and 4	6 to 16†
Flooring 5/4.....	$1\frac{1}{16}$	3½, 4½	6 to 16†
Ceiling.....	$\frac{3}{8}, \frac{7}{16}, \frac{1}{2}, \frac{5}{8}, \frac{3}{4}$	.....	6 to 16†
Partition.....	$\frac{3}{4}$	.....	8 to 16†
German siding.....	$\frac{13}{16}$	5½	
Bevel siding.....	$\frac{1}{2}$	4, 6	
Base, S 4 S.....	$\frac{13}{16}$	4, 5, 6, 7	
Roofers.....	$\frac{13}{16}$	5½, 7½, 9½, 11½	
Factory flooring, T & G.....	$1\frac{3}{4}, 2\frac{1}{4}, 2\frac{3}{4}$	4¼ to 8¼	
Finish 1×4, 1×5, 1×6.....	$\frac{13}{16}$	3¾, 4¾, 5¾	6 to 16†
Finish 1×8 and wider, S 4 S.....	$\frac{13}{16}$	.....	6 to 16†
Boards and dimension 4/4, 5/4, 6/4, 8/4, S 1 S.....	$\frac{1}{4}$ for dressing		
Boards and dimension 4/4, 5/4, S 2 S.....	$\frac{3}{16}$ for dressing		
Boards and dimension 6/4 and thicker, S 2 S.....	$\frac{1}{4}$ for dressing		

\* Rough lumber lengths are from 8 to 16 feet in multiples of 2 feet.  
 † In multiples of 1 foot.

TABLE XXXVII.—EASTERN WHITE PINE

Sizes to which the Product is Manufactured \*

Kind of Product	Thickness.† Inches	Width of Face.† Inches
Lumber green, 4/4.....	$\frac{15}{16}$ ( $\frac{11}{16}$ , $\frac{31}{32}$ , 4/4)	
Lumber 4/4, S 1 S.....	$\frac{13}{16}$ ( $\frac{3}{4}$ , $\frac{25}{32}$ )	
Lumber 4/4, S 2 S.....	$\frac{13}{16}$ ( $\frac{3}{4}$ , $\frac{25}{32}$ )	
Dimension, rough, green, 2×4...	$1\frac{3}{4}$ ( $1\frac{5}{8}$ , $1\frac{11}{16}$ , $1\frac{7}{8}$ , 8/4)	4 ( $3\frac{3}{8}$ , $3\frac{3}{16}$ , $3\frac{7}{8}$ )
Dimension, rough, green, 2×6...	$1\frac{3}{4}$ ( $1\frac{5}{8}$ , $1\frac{11}{16}$ , $1\frac{7}{8}$ , $1\frac{15}{16}$ , 8/4)	6 ( $5\frac{11}{16}$ , $5\frac{3}{4}$ , $5\frac{13}{16}$ )
Dimension 2×4, S 1 S 1 E.....	$1\frac{5}{8}$ ( $1\frac{9}{16}$ , $1\frac{11}{16}$ , $1\frac{3}{4}$ )	$3\frac{3}{4}$ ( $3\frac{3}{8}$ , $3\frac{11}{16}$ )
Dimension 2×6, S 1 S 1 E.....	$1\frac{5}{8}$ ( $1\frac{9}{16}$ , $1\frac{11}{16}$ , $1\frac{3}{4}$ )	$5\frac{1}{4}$ ( $5\frac{5}{8}$ , $5\frac{11}{16}$ )
Dimension 2×8, S 1 S 1 E.....	$1\frac{5}{8}$ ( $1\frac{9}{16}$ , $1\frac{11}{16}$ , $1\frac{3}{4}$ )	$7\frac{5}{8}$
Dimension 2×10, S 1 S 1 E.....	$1\frac{5}{8}$ ( $1\frac{9}{16}$ , $1\frac{11}{16}$ , $1\frac{3}{4}$ )	$9\frac{5}{8}$
Dimension 2×12, S 1 S 1 E.....	$1\frac{5}{8}$ ( $1\frac{9}{16}$ , $1\frac{11}{16}$ , $1\frac{3}{4}$ )	$11\frac{1}{2}$
Flooring 1×4, D & M.....	$\frac{13}{16}$ ( $\frac{25}{32}$ )	$3\frac{1}{4}$ ( $3\frac{1}{8}$ , $3\frac{3}{16}$ , $3\frac{3}{8}$ , $3\frac{1}{2}$ )
Flooring 1×6, D & M.....	$\frac{13}{16}$ ( $\frac{25}{32}$ )	$5\frac{1}{4}$ ( $5\frac{1}{8}$ , $5\frac{3}{16}$ , $5\frac{3}{8}$ )
Ceiling, S 1 S.....	$\frac{3}{8}$ , $\frac{5}{8}$ , $\frac{3}{4}$ , $1\frac{1}{16}$ ( $\frac{25}{32}$ )	
Shiplap 1×8.....	$\frac{13}{16}$	$7\frac{1}{8}$ ( $7$ , $7\frac{1}{16}$ , $7\frac{1}{4}$ , $7\frac{3}{8}$ , $7\frac{1}{2}$ )
Shiplap 1×10.....	$\frac{13}{16}$	$9\frac{1}{8}$ ( $9$ , $9\frac{1}{16}$ , $9\frac{3}{16}$ , $9\frac{1}{4}$ , $9\frac{3}{8}$ , $9\frac{1}{2}$ )
Drop siding 1×8.....	$\frac{13}{16}$	$7\frac{1}{4}$ ( $6\frac{7}{8}$ , $7\frac{1}{8}$ , $7\frac{3}{16}$ , $7\frac{3}{8}$ )
Drop siding 1×10.....	$\frac{13}{16}$	$9\frac{1}{4}$ ( $8\frac{7}{8}$ , $9\frac{1}{8}$ , $9\frac{3}{16}$ , $9\frac{3}{8}$ )
Grooved roofing 1×8.....	$\frac{13}{16}$	$7\frac{1}{2}$ ( $7$ , $7\frac{1}{8}$ , $7\frac{3}{8}$ , $7\frac{11}{16}$ )
Beveled siding 1×4.....	.....	$3\frac{1}{2}$ ( $3\frac{3}{8}$ , $3\frac{7}{16}$ , $3\frac{3}{4}$ )
Beveled siding 1×6.....	.....	$5\frac{1}{2}$ ( $5\frac{1}{4}$ , $5\frac{3}{8}$ , $5\frac{7}{16}$ , $5\frac{3}{4}$ )

\* The Northern Pine Manufacturers' Association which has formulated and published "Rules for the Grading of Pine and Hemlock Lumber" does not issue an official standard of sizes for rough or manufactured products. Although most manufacturers work their product to uniform sizes, there are numerous variations from the general practice, owing to the diversified demands of the different markets in which white pine is sold.

† The first figure represents the dimension most commonly used. The figures in parentheses are those used by some manufacturers. The table is based on data submitted by the Secretary, at the semi-annual meeting of the Northern Pine Manufacturers' Association, on Aug. 11, 1908. See American Lumberman, Aug. 15, 1908, page 46.

TABLE XXXVIII.—DOUGLAS FIR, SPRUCE, CEDAR, AND WESTERN HEMLOCK

Standard Sizes of Re-manufactured Products Adopted by the West Coast Lumbermen's Association

Product	Thickness. Inches	Width. Inches	Standard Lengths. Feet
Flooring 4/4.....	$\frac{13}{16}$	2 $\frac{1}{4}$ , 3 $\frac{1}{4}$ , 5 $\frac{1}{8}$ Face	} Multiples of 1 Foot
Flooring 5/4.....	1 $\frac{1}{16}$	2 $\frac{1}{4}$ , 3 $\frac{1}{4}$ , 5 $\frac{1}{8}$ Face	
Ceiling.....	$\frac{3}{16}$ , $\frac{5}{16}$ , $\frac{9}{16}$ , $\frac{11}{16}$	3 $\frac{1}{4}$ , 5 $\frac{1}{8}$ Face	
Partition.....	$\frac{11}{16}$	3 $\frac{1}{4}$ , 5 $\frac{1}{8}$ Face	
Drop siding.....	$\frac{3}{4}$	3 $\frac{1}{4}$ , 5 $\frac{1}{8}$ , 7	
Finish 4/4, S 1 S 1 E or S 2 S 1 E.	$\frac{3}{4}$	3 $\frac{1}{2}$ , 4 $\frac{1}{2}$ , 5 $\frac{1}{2}$ , 7 $\frac{1}{4}$ , 9 $\frac{1}{4}$ , 11 $\frac{1}{4}$ , 13, 15	} Multiples of 2 Feet
Finish 5/4, S 1 S 1 E or S 2 S 1 E.	$\frac{11}{16}$	3 $\frac{1}{2}$ , 4 $\frac{1}{2}$ , 5 $\frac{1}{2}$ , 7 $\frac{1}{4}$ , 9 $\frac{1}{4}$ , 11 $\frac{1}{4}$ , 13, 15	
Finish 6/4, S 1 S 1 E or S 2 S 1 E.	1 $\frac{5}{16}$	3 $\frac{1}{2}$ , 4 $\frac{1}{2}$ , 5 $\frac{1}{2}$ , 7 $\frac{1}{4}$ , 9 $\frac{1}{4}$ , 11 $\frac{1}{4}$ , 13, 15	
Finish 8/4, S 1 S 1 E or S 2 S 1 E.	1 $\frac{3}{4}$	3 $\frac{1}{2}$ , 4 $\frac{1}{2}$ , 5 $\frac{1}{2}$ , 7 $\frac{1}{4}$ , 9 $\frac{1}{4}$ , 11 $\frac{1}{4}$ , 13, 15	
Shiplap and D & M, 4/4.....	$\frac{3}{4}$	7, 9, 11	
Dimension 8/4, S 1 S 1 E or S 4 S.	1 $\frac{5}{8}$	3 $\frac{5}{8}$ , 5 $\frac{5}{8}$ , 7 $\frac{1}{2}$ , 9 $\frac{1}{2}$ , 11 $\frac{1}{2}$	
Dimension 12/4, S 1 S 1 E or S 4 S.	2 $\frac{1}{2}$	5, 7 $\frac{1}{2}$ , 9 $\frac{1}{2}$ , 11 $\frac{1}{2}$	
Timbers 4×4 and larger.....	$\frac{1}{2}$ off	$\frac{1}{2}$ off	

TABLE XXXIX.—SOUTHERN CYPRESS

Standard Sizes for Re-manufactured Products Adopted by The Southern Cypress Association \*

## Thickness:

- 4/4 lumber S 1 S or S 2 S shall be  $\frac{1}{2}$ -inch thick.  
 5/4 lumber S 1 S or S 2 S shall be  $1\frac{1}{8}$ -inches thick.  
 6/4 lumber S 1 S or S 2 S shall be  $1\frac{3}{8}$ -inches thick.  
 8/4 lumber S 1 S or S 2 S shall be  $1\frac{5}{8}$ -inches thick.  
 10/4 lumber S 1 S or S 2 S shall be  $2\frac{1}{4}$ -inches thick.  
 12/4 lumber S 1 S or S 2 S shall be  $2\frac{3}{4}$ -inches thick.  
 16/4 lumber S 1 S or S 2 S shall be  $3\frac{3}{4}$ -inches thick.  
 All flooring and partition shall be S 2 S and C M.  
 4/4 flooring shall be  $\frac{3}{16}$ -inch thick.  
 5/4 flooring shall be  $1\frac{1}{8}$ -inches thick.  
 6/4 flooring shall be  $1\frac{3}{8}$ -inches thick.  
 8/4 flooring shall be  $1\frac{5}{8}$ -inches thick.  
 10/4 flooring shall be  $2\frac{1}{4}$ -inches thick.  
 12/4 flooring shall be  $2\frac{3}{4}$ -inches thick.  
 $\frac{3}{8}$ -inch ceiling shall be worked to  $\frac{5}{16}$ -inch S 1 S only.  
 $\frac{1}{2}$ -inch ceiling shall be worked to  $\frac{7}{16}$ -inch S 1 S only.  
 $\frac{5}{8}$ -inch ceiling shall be worked to  $\frac{9}{16}$ -inch S 1 S only.  
 $\frac{3}{4}$ -inch ceiling shall be worked to  $1\frac{1}{16}$ -inch S 1 S only.  
 $\frac{3}{8}$ -inch panel stock S 2 S shall be  $\frac{7}{32}$ -inch.  
 $\frac{1}{2}$ -inch panel stock S 2 S shall be  $\frac{5}{16}$ -inch.  
 $\frac{5}{8}$ -inch panel stock S 2 S shall be  $\frac{7}{16}$ -inch.  
 $\frac{3}{4}$ -inch panel stock S 2 S shall be  $\frac{9}{16}$ -inch.  
 3- by 3-inch to 8- by 8-inch turning squares S 4 S shall be  $\frac{1}{4}$  inch less than the rough sizes.  
 Drop siding either D & M or shiplap shall be  $1\frac{3}{8}$ -inch thick.  
 Shiplap or D & M shall be  $1\frac{3}{8}$ -inch thick.  
 Grooved roofing shall be  $1\frac{3}{8}$ -inch thick.

## Widths:

- All lumber S 1 E takes  $\frac{3}{8}$ -inch, S 2 E  $\frac{1}{2}$ -inch.  
 4/4-, 5/4-, and 6/4-inch flooring, ceiling and partition shall be  $2\frac{1}{4}$ -,  $3\frac{1}{4}$ -,  $4\frac{1}{4}$ -, or  $5\frac{1}{4}$ -inch face.  
 5/4-, 6/4-, 8/4-inch baluster stock shall be the same width as finished thickness.  
 Drop siding, D & M shall be  $3\frac{1}{4}$ - and  $5\frac{1}{4}$ -inch face. When worked shiplap it shall be  $5\frac{1}{2}$ -inches over all, allowing  $\frac{1}{2}$ -inch for lap.  
 8-, 10- and 12-inch shiplap shall be worked 7-, 9- and 11-inch face,  $\frac{1}{2}$ -inch lap.  
 8-, 10-, and 12-inch D & M shall be worked  $7\frac{1}{4}$ -,  $9\frac{1}{4}$ - and  $11\frac{1}{4}$ -inch face.  
 Grooved roofing shall be worked  $9\frac{1}{2}$ - and  $11\frac{1}{2}$ -inch face; size of groove,  $\frac{1}{2}$ -inch wide,  $\frac{1}{4}$ -inch deep, located  $1\frac{3}{16}$ -inches from outer edge of groove to outer edge of board.  
 Bevel siding or bevel cribbing shall be worked  $\frac{1}{2}$ -inch less in width than the rough strip measure.

\* Adopted Nov. 28, 1921.

TABLE XL.—EASTERN SPRUCE

Standard Sizes Adopted by the Spruce Manufacturers' Association of  
West Virginia \*

Kind of Product	Thickness. Inches	Width. Inches	Length. Feet
Dressed stock 4/4, D 1 S or D 2 S.....	$\frac{3}{16}$ scant in thickness		
Dressed stock 5/4 and 6/4, D 1 S or D 2 S....	$\frac{1}{8}$ scant in thickness		
Dressed stock 8/4 and 12/4, D 1 S or D 2 S...	$\frac{1}{4}$ scant in thickness		
Dressed stock, 4/4 5/4, 6/4, 8/4 and 12/4 D 1 E or D 2 E. From 3 to 8 inches.....	.....	$\frac{3}{8}$ scant	
Dressed stock, 4/4, 5/4 and 6/4, D 1 E or D 2 E. From 9 to 12 inches.....	.....	$\frac{1}{2}$ scant	
Matched or T & G stock.....	.....	$\frac{3}{4}$ scant face	
First and seconds.....	.....	.....	10 and up
Selects.....	.....	.....	10 and up
Dressing.....	.....	.....	10 and up
Merchantable.....	.....	.....	8 and up
Box.....	.....	.....	6 and up
Mill culls.....	.....	.....	6 and up

\* Effective Jan. 25, 1910.

TABLE XLI.—STANDARD THICKNESS FOR HARDWOOD LUMBER \*

Standard Thickness †

Rough. Inches	S 2 S.‡ Inches	Rough. Inches	S 2 S.‡ Inches
$\frac{3}{8}$	$\frac{3}{16}$	$1\frac{1}{2}$	$1\frac{11}{32}$
$\frac{1}{2}$	$\frac{5}{16}$	2	$1\frac{3}{4}$
$\frac{5}{8}$	$\frac{7}{16}$	$2\frac{1}{2}$	$2\frac{1}{4}$
$\frac{3}{4}$	$\frac{9}{16}$	3	$2\frac{3}{4}$
1	$1\frac{13}{16}$	$3\frac{1}{2}$	$3\frac{1}{4}$
$1\frac{1}{4}$	$1\frac{3}{32}$	4	$3\frac{3}{4}$

\* Adopted by the American Hardwood Manufacturers' Association, Feb. 1, 1919.

† Lumber must be standard thickness when shipping dry. Lumber showing greater variation in thickness than  $\frac{1}{16}$ -inch at any point in stock cut  $\frac{1}{2}$ -inch or less, or  $\frac{1}{2}$ -inch in  $\frac{3}{8}$ - and  $\frac{1}{2}$ -inch stock, or  $\frac{1}{4}$ -inch in 1- to 2-inch stock, or  $\frac{3}{8}$ -inch in  $2\frac{1}{2}$ -inch or thicker stock, must be measured at the thinnest part and classed as missawn, and graded and reported as such.

‡ Lumber S 1 S only, must be  $\frac{1}{16}$ -inch greater in thickness than when S 2 S.

## SHRINKAGE OF WOOD IN SEASONING

TABLE XLII.—AVERAGE SHRINKAGE OF WOOD \*

Species	Locality	Shrinkage from a Green to an Over Dry Condition †		
		Volume. Per Cent	Radial. Per Cent	Tangential. Per Cent
<b>HARDWOODS:</b>				
Ash, black.....	Michigan	15.2	5.0	7.8
Ash, white.....	Arkansas	12.6	4.3	6.4
Basswood.....	Wisconsin	14.5	6.2	8.4
Beech.....	Pennsylvania	16.5	6.8	9.9
Birch, yellow.....	Wisconsin	17.0	7.9	9.0
Buckeye.....	Tennessee	12.0	3.5	2.8
Butternut.....	Tennessee	11.1	3.0	6.5
Cherry.....	Pennsylvania	11.5	3.7	7.1
Chestnut.....	Tennessee	18.9	3.4	6.8
Cucumber.....	Tennessee	13.6	5.2	8.8
Elm, white.....	Pennsylvania	14.4	4.2	9.5
Hickory, shellbark.....	Mississippi	17.6	7.4	11.2
Locust, black.....	Tennessee	9.8	4.4	6.9
Maple, hard.....	Pennsylvania	14.7	4.8	9.2
Oak, red.....	Arkansas	14.5	4.2	8.3
Oak, white.....	Arkansas	15.8	6.2	8.3
Oak, white.....	Louisiana	16.9	5.4	9.5
Poplar, yellow.....	Tennessee	11.4	4.1	6.9
Sycamore.....	Tennessee	14.8	5.2	7.9
Tupelo.....	Louisiana	12.4	4.4	7.9
Walnut, black.....	Kentucky	11.3	5.2	7.1
<b>CONIFERS:</b>				
Cedar, western red.....	Washington	8.6	2.5	5.6
Cedar, white.....	Wisconsin	7.0	2.1	4.7
Cypress, bald.....	Louisiana	11.5	3.8	6.0
Douglas fir.....	Washington	12.3	5.0	8.3
Fir, balsam.....	Wisconsin	10.8	2.8	6.6
Hemlock.....	Wisconsin	9.2	2.3	5.0
Larch, western.....	Montana	13.2	4.2	8.1
Pine, loblolly.....	Florida	12.6	5.5	7.5
Pine, lodgepole.....	Montana	11.9	4.6	6.8
Pine, longleaf.....	Louisiana	12.8	6.0	7.6
Pine, Norway.....	Wisconsin	11.5	4.6	7.2
Pine, sugar.....	California	8.4	2.9	5.6
Pine, western white.....	Montana	11.5	4.1	7.4
Pine, western yellow.....	Arizona	9.2	4.1	6.4
Spruce, Englemann.....	Colorado	10.3	3.0	6.2
Spruce, red.....	Tennessee	11.8	3.8	7.8
Spruce, Sitka.....	Washington	11.2	4.5	7.4
Spruce, white.....	Wisconsin	14.8	3.7	7.3
Tamarack.....	Wisconsin	13.6	3.7	7.4

\* Data from The Seasoning of Wood, by H. S. Betts, U. S. Dept. of Agriculture, Bull. No. 552, Washington, 1917.

† The shrinkage from a green to a kiln-dried condition (8 per cent moisture), is about 75 per cent of that for the oven-dried condition. The shrinkage from a green to an air-dry condition (12 to 15 per cent), is about 50 per cent of the shrinkage to an oven-dry condition.

TABLE XLIII.—AVERAGE SHRINKAGE IN THICKNESS, OF HARDWOOD LUMBER, GREEN FROM THE SAW \*

Species	2 Months, Air-dry. Per Cent	4 Months, Air-dry. Per Cent	6 Months, Air-dry. Per Cent
Ash .....	3 $\frac{1}{2}$	6	6
Basswood .....	3 $\frac{1}{2}$	5	7
Beech .....	3	3 $\frac{1}{2}$	7
Butternut .....	4	6	6 $\frac{1}{2}$
Cherry .....	2 $\frac{1}{2}$	4 $\frac{1}{2}$	6 $\frac{1}{2}$
Chestnut .....	6	6 $\frac{1}{2}$	7 $\frac{1}{2}$
Cottonwood .....	6	8 $\frac{1}{2}$	10
Cypress .....	8	10	10
Elm .....	5	7	9
Gum .....	4	7 $\frac{1}{2}$	9 $\frac{1}{2}$
Hickory .....	2 $\frac{2}{3}$	4	5 $\frac{1}{2}$
Maple .....	4	7 $\frac{1}{2}$	8
White ash, plain .....	3 $\frac{1}{2}$	5	6 $\frac{1}{2}$
Red oak, plain .....	4	6	8
White oak, quartered .....	2 $\frac{1}{2}$	5	7
Red oak, quartered .....	3 $\frac{1}{2}$	6	7 $\frac{1}{2}$
Poplar .....	4	6 $\frac{1}{2}$	8 $\frac{1}{2}$
Sycamore, plain .....	3	5	6
Sycamore, quartered .....	1 $\frac{1}{2}$	4 $\frac{1}{2}$	6 $\frac{1}{2}$
Tupelo .....	4	4	6 $\frac{1}{2}$
Walnut .....	3	5 $\frac{1}{2}$	6

\* From a report of the Secretary of the Hardwood Manufacturers' Association of the United States. Hardwood Record, Jan. 25, 1909, page 29.



## HOW TO MEASURE THE CONDITIONS IN SEASONED LUMBER

### HOW TO MEASURE THE CONDITIONS IN SEASONED LUMBER \*

*Moisture Content.*—To test for moisture content select several boards from different parts of the pile and cut a section about an inch wide along the grain from near the center of each. Sections cut less than one foot from the ends of the boards are usually affected by end drying. First, remove all splinters and loose particles from the outer surfaces and label the sections so that they may be identified later. Weigh the sections separately on a sensitive balance to an accuracy of 1 per cent and record the weights of each. The next step is to place the sections on hot steam pipes or in a drying oven heated to about 212° F. When they cease losing weight reweigh them to the same accuracy. The first weight minus the second weight represents the weight of water dried out of the wood. Divide the weight of water by the dry weight of the wood and multiply by 100. The result is the moisture content of the wood expressed in per cent of the dry weight.

Lumber, the moisture content of which is under 6 per cent, may be considered thoroughly kiln dried, while a moisture content of from 10 to 15 per cent indicates thoroughly air dried lumber.

*Moisture Distribution.*—The method of testing lumber for distribution of moisture is similar to that of the moisture test described, except that the sections are resawed twice, into three equal thicknesses. The two outside parts (weighed together) and the center part of each section are labeled and at once weighed separately on a sensitive balance to an accuracy of 1 per cent. These weights should be recorded both on the outside and center portions and on paper. The parts should now be completely dried on steam pipes or in an oven until they cease losing weight, when they should be reweighed. The first weights minus the second equal the weights of water evaporated. The weights of water times 100 and divided by the weights of the dry wood give the moisture contents of the outer and inner parts of the sections in per cent of the dry weights of the wood.

*Shrinkage.*—The method of measuring the shrinkage of wood is as follows: (1) Draw a line in pencil across the board, using a square. The edges of the board should be surfaced so as to present smooth faces. Place a small hook scale, graduated in fiftieths or one hundredths of an inch, along the pencil mark. Observe the width of the board on the scale to the nearest fiftieth or one hundredth of an inch and record the reading. If the board is now placed over steam pipes or in an oven until it ceases to lose weight it may be remeasured in the manner described. The first measurement minus the dry measurement leaves the amount of shrinkage. This difference times 100, divided by the original measurement equals the shrinkage of the board in per cent of the original measurement. This process may be continued around the board and the cross-sections computed if one desires to know the shrinkage in cross-section.

\* From an article with this title by James E. Imrie, American Lumberman, March 10, 1917, page 38.

# LUMBER PRODUCTION BY

## TABLE XLIV.—LUMBER PRODUCTION

As Reported by The Bureau of Census and The Forest

	1879, M. Ft. Bd. M.	1889, M. Ft. Bd. M.	1899, M. Ft. Bd. M.	1904, M. Ft. Bd. M.	1905, M. Ft. Bd. M.	1906, M. Ft. Bd. M.	1907, M. Ft. Bd. M.	1908, M. Ft. Bd. M.	1909 M. Ft. Bd. M.
Alabama.....	251,851	589,480	1,101,386	1,243,988	843,897	1,009,783	1,224,967	1,152,079	1,691,001
Alaska.....	2	2,816	6,571	2	2	2	2	2	2
Arizona.....	10,715	5,320	36,182	55,601	88,825 <sup>3</sup>	56,960	72,134	43,287	62,731
Arkansas.....	172,503	537,884	1,623,987	1,680,536	1,488,589	1,839,368	1,988,504	1,656,991	2,111,300
California.....	304,795	517,781	737,035	1,077,499	1,061,608	1,348,559	1,345,943	996,115	1,143,507
Colorado.....	63,792	79,951	133,746	141,914	56,753	110,212	134,230	117,036	141,710
Connecticut.....	64,427	48,957	108,093	69,376	69,845	124,880	140,011	137,855	168,371
Delaware.....	31,572	23,466	35,955	30,416	12,260	44,487	50,892	41,184	55,440
Florida.....	247,627	411,869	790,373	812,693	658,007	888,137	839,058	730,906	1,201,734
Georgia.....	451,792	575,152	1,311,917	1,135,910	712,604	831,675	853,697	904,668	1,342,249
Idaho.....	18,204	27,800	65,363	211,447	212,725	418,944	513,788	518,625	645,800
Illinois.....	334,244	221,810	388,469	211,545	119,065	141,374	141,317	123,319	170,181
Indiana.....	915,943	755,407	1,036,999	563,853	352,362	447,808	504,790	411,868	556,418
Iowa.....	412,578	571,166	352,411	281,521	129,472	163,747	144,271	97,242	132,021
Kansas.....	45,281	4,037	10,665	2,120	1,272	170	2	2	3
Kentucky.....	305,684	423,185	774,651	586,371	464,676	661,299	912,908	658,539	860,712
Louisiana.....	133,472	303,726	1,115,366	2,459,321	2,293,809	2,796,395	2,972,119	2,722,421	3,551,918
Maine.....	566,656	597,481	784,647	863,860	745,705	1,088,747	1,103,808	929,350	1,111,565
Maryland.....	123,336	82,119	183,711	166,469	163,749	219,098	213,786	168,534	267,939
Massachusetts.....	205,244	211,588	344,190	262,467	252,804	354,483	364,231	364,526	361,200
Michigan.....	4,172,572	4,300,172	3,018,338	2,006,670	1,719,687	2,094,279	1,827,685	1,478,252	1,889,724
Minnesota.....	563,974	1,084,377	2,342,338	1,942,248	1,925,804	1,794,144	1,660,716	1,286,122	1,561,508
Mississippi.....	168,747	454,417	1,206,265	1,727,391	1,299,390	1,840,250	2,094,485	1,861,016	2,572,669
Missouri.....	399,744	402,052	723,754	553,940	362,217	507,084	548,774	458,938	660,159
Montana.....	21,420	89,511	255,685	236,430	189,291	328,727	343,814	311,533	308,582
Nebraska.....	13,585	8,561	4,665	1,862	5	2	2	2	2
Nevada.....	21,545	2	725	2	6	2	2	2	2
New Hampshire.....	292,267	277,063	572,477	491,591	340,727	539,259	754,023	606,760	649,606
New Jersey.....	109,679	34,052	74,118	44,058	17,704	36,253	39,942	34,930	61,620
New Mexico.....	11,195	26,112	30,880	81,113	6	103,079	113,204	79,439	91,987
New York.....	1,184,220	925,417	878,448	581,976	750,280	750,280	848,894	781,391	681,440
North Carolina.....	241,822	514,692	1,286,638	1,318,411	1,080,602	1,222,974	1,622,387	1,136,796	2,177,715
North Dakota.....	2	2	2,030	2	2	2	2	2	2
Ohio.....	910,832	565,315	990,497	420,905	331,552	438,775	529,087	459,259	542,904
Oklahoma and Indian Territory..	2	2,552	22,104	30,980	11,667	49,737	140,015	158,756	225,730
Oregon.....	177,171	446,483	734,538	987,107	1,262,610	1,604,894	1,635,563	1,468,158	1,898,995
Pennsylvania.....	1,733,844	2,133,316	2,333,278	1,738,972	1,397,164	1,620,881	1,734,729	1,203,041	1,462,771
Rhode Island.....	18,469	7,633	18,528	15,398	14,054	21,528	32,855	30,528	25,489
South Carolina.....	185,772	198,764	466,429	609,769	466,478	566,928	649,058	560,888	897,660
South Dakota.....	2	28,233 <sup>7</sup>	31,704 <sup>7</sup>	13,705	11,502	22,634	34,841	25,859	31,057
Tennessee.....	302,673	460,263	950,958	775,885	540,920	634,587	894,968	790,642	1,223,549
Texas.....	328,968	842,648	1,232,404	1,406,473	929,863	1,741,473	2,229,590	1,524,008	2,099,130
Utah.....	25,709	14,320	17,548	12,630	3,618	7,768	14,690	15,059	12,638
Vermont.....	322,942	384,476	375,809	337,238	266,676	329,422	373,660	304,017	351,571
Virginia.....	315,939	415,512	959,119	949,797	715,197	1,063,241	1,412,477	1,198,725	2,101,716
Washington.....	160,176	1,063,584	1,429,032	2,485,628	3,917,166	4,305,053	3,777,606	2,915,928	3,862,916
West Virginia.....	180,112	301,958	778,051	855,889	672,902	976,173	1,395,979	1,097,015	1,472,942
Wisconsin.....	1,542,021	2,866,153	3,389,166	2,623,157	2,543,503	2,331,305	2,003,279	1,613,315	2,025,038
Wyoming.....	2,960	6,417	16,963	7,990	4,360	13,213	17,479	18,822	28,602
All Others.....	42,751			13,039			5,891	10,627	15,946
United States.....	18,091,356	23,845,046	35,084,166	34,127,165	30,502,961	37,549,067	40,256,154	33,224,369	44,509,761
Lath (M.).....			2,523,998	2,647,847	3,111,157	3,812,807	3,663,602	3,494,718	3,703,195
Shingles (M.).....			12,102,017	14,546,551	15,340,909	11,858,260	11,824,475	12,106,483	14,907,371

<sup>1</sup> Lumber cut for the years 1900 to 1903, inclusive, is not available. <sup>2</sup> Not reported separately. <sup>3</sup> Includes New

<sup>8</sup> Preliminary report.

STATES, 1879 TO 1920

IN THE UNITED STATES, 1879 TO 1920

Service of the United States Department of Agriculture

1910, M. Ft. Bd. M.	1911, M. Ft. Bd. M.	1912, M. Ft. Bd. M.	1913, M. Ft. Bd. M.	1914, M. Ft. Bd. M.	1915, M. Ft. Bd. M.	1916, M. Ft. Bd. M.	1917, M. Ft. Bd. M.	1918, M. Ft. Bd. M.	1919, M. Ft. Bd. M.	1920, <sup>s</sup> M. Ft. Bd. M.
1,465,623	1,226,212	1,378,151	1,523,936	1,494,732	1,500,000	1,720,000	1,555,000	1,270,000	1,798,746	1,439,200
2	2	2	2	2	2	2	2	2	2	2
72,655	73,139	76,287	77,363	78,667	75,915	93,270	79,022	83,661	73,655	2
1,844,446	1,777,303	1,821,811	1,911,647	1,796,780	1,800,000	1,910,000	1,765,000	1,470,000	1,772,157	1,452,200
1,254,826	1,207,561	1,203,059	1,183,380	1,303,183	1,130,000	1,420,000	1,417,068	1,277,084	1,259,363	1,513,000
121,398	95,908	88,451	74,602	102,117	74,500	77,580	71,500	56,882	64,864	2
126,463	124,661	109,251	93,730	81,883	90,000	75,000	66,000	64,000	86,705	2
46,642	23,853	28,285	18,039	25,517	25,000	12,000	8,500	6,000	27,437	2
992,091	983,824	1,067,525	1,055,047	1,073,821	1,110,000	1,425,000	1,230,000	950,000	1,137,432	1,000,900
1,041,617	801,611	941,291	844,284	1,026,191	1,000,000	1,000,000	740,000	515,000	893,965	761,800
745,984	765,670	713,575	652,616	763,508	777,000	849,600	760,000	802,529	765,388	970,000
113,506	96,651	122,528	102,902	66,227	110,000	60,000	45,000	42,000	64,628	2
422,963	360,613	401,017	332,993	298,571	350,000	270,000	240,000	250,000	282,487	2
75,446	59,974	46,593	21,676	11,443	35,000	20,000	13,436	14,200	18,493	2
2	2	2	2	2	2	534 <sup>4</sup>	4,255 <sup>4</sup>	8,401 <sup>4</sup>	2	2
753,556	632,415	641,296	541,531	596,392	560,000	525,000	360,000	340,000	512,078	421,100
3,733,900	3,566,456	3,876,211	4,161,560	3,956,434	3,900,000	4,200,000	4,210,000	3,450,000	3,163,871	3,120,000
860,273	828,417	862,128	834,673	992,594	1,000,000	930,000	770,000	650,000	596,116	505,600
154,554	144,078	174,320	140,469	162,097	165,000	90,237	68,000	71,000	113,362	2
239,206	273,717	259,329	224,580	143,094	250,000	210,000	155,000	175,000	166,841	2
1,681,091	1,466,754	1,488,827	1,222,983	1,214,435	1,100,000	1,230,000	1,065,000	940,000	875,891	749,800
1,457,734	1,485,015	1,436,726	1,149,704	1,312,230	1,100,000	1,220,000	1,075,000	1,005,000	699,639	576,300
2,122,205	2,041,615	2,381,898	2,610,581	2,280,966	2,300,000	2,730,000	2,425,000	1,935,000	2,390,135	2,224,000
501,691	418,586	422,470	416,608	370,571	350,000	260,000	275,000	273,000	321,383	2
319,089	228,416	272,174	357,974	317,842	328,000	383,900	350,000	340,000	287,378	2
2	2	2	2	2	2	2	2	2	2	2
2	2	2	2	2	2	2	2	2	20,335	2
443,907	388,619	479,499	309,424	482,744	500,000	385,000	290,000	350,000	338,777	248,600
36,542	28,639	34,810	27,248	48,748	45,000	40,000	25,000	19,500	36,888	2
83,544	83,728	82,650	65,818	57,167	65,787	91,600	93,000	88,915	86,808	2
506,074	526,283	502,351	457,720	486,195	475,000	400,000	360,000	335,000	357,764	2
1,824,722	1,798,724	2,193,308	1,957,258	2,227,854	2,090,000	2,100,000	1,460,000	1,240,000	1,654,435	1,246,700
2	2	2	2	2	2	2	2	2	2	2
490,039	427,161	499,834	414,943	286,063	400,000	280,000	225,000	235,000	280,076	2
164,663	143,869	168,806	140,284	200,594	230,000	240,000	240,000	195,000	168,403	2
2,084,633	1,803,698	1,916,160	2,098,467	1,817,875	1,690,000	2,222,000	2,585,000	2,710,250	2,577,403	3,317,000
1,241,199	1,048,606	992,180	781,547	864,710	950,000	750,000	565,000	530,000	630,471	520,000
14,392	9,016	14,421	14,984	15,902	15,900	18,000	10,646	13,100	11,030	2
706,831	584,872	816,930	752,184	701,540	800,000	857,000	745,000	545,000	621,679	610,500
16,340	13,046	20,986	19,103	18,744	22,562	29,650	29,045	29,533	42,970	2
1,016,475	914,579	932,572	872,311	885,035	800,000	700,000	630,000	630,000	792,132	779,800
1,884,134	1,681,080	1,902,201	2,081,471	1,554,005	1,750,000	2,100,000	1,735,000	1,350,000	1,379,774	1,328,800
11,786	10,573	9,055	5,403	8,680	10,892	9,385	8,567	9,815	11,917	2
284,815	239,254	235,983	194,647	249,608	260,000	200,000	170,000	160,000	218,479	164,500
1,652,192	1,359,790	1,569,997	1,273,953	1,488,070	1,500,000	1,335,000	1,060,000	855,000	1,098,038	1,014,400
4,097,492	4,064,754	4,099,775	4,592,053	3,946,189	3,950,000	4,494,000	4,568,500	4,603,123	4,961,220	5,525,000
1,376,737	1,387,786	1,318,732	1,249,559	1,118,450	1,100,000	1,220,000	890,000	720,000	763,103	697,600
1,891,291	1,761,986	1,498,876	1,493,353	1,391,001	1,210,000	1,600,000	1,385,000	1,275,000	1,116,338	1,059,900
30,931	33,309	13,560	12,940	11,852	17,000	18,495	8,700	7,501	8,674	2
12,594	11,786	22,525	19,461	15,672	2	2	2	2	3,345	2,965,200
40,018,282	37,003,207	39,158,414	38,387,009	37,346,023	37,011,656	39,807,251	35,831,239	31,890,494	34,522,076	33,798,800
2,986,684	2,971,110	2,719,163	.....	.....	2,745,134	2,754,688	2,281,738	1,362,187	1,724,078	.....
12,976,867	12,113,867	12,037,685	.....	.....	8,459,378	9,371,333	8,696,513	5,690,182	9,192,704	.....

Mexico and Nevada. <sup>4</sup> Includes Nebraska. <sup>5</sup> Included in Kansas. <sup>6</sup> Included in Arizona. <sup>7</sup> Includes North Dakota.

## LUMBER PRODUCTION BY

### TABLE XLV.—LUMBER PRODUCTION IN THE

Based on Reports of the Bureau of Census and the

	1920,* M. Ft. Bd. M.	1919, M. Ft. Bd. M.	1918, M. Ft. Bd. M.	1917, M. Ft. Bd. M.	1916, M. Ft. Bd. M.	1915, M. Ft. Bd. M.	1914, M. Ft. Bd. M.	1913, M. Ft. Bd. M.
Southern yellow pine.	11,091,000	13,062,938	10,845,000	13,539,464	15,055,000	14,700,000	14,472,804	14,839,363
Douglas fir . . . . .	6,960,000	5,902,169	5,820,000	5,585,000	5,416,000	4,431,349	4,763,693	5,556,096
Oak . . . . .	2,500,000	2,708,280	2,025,000	2,250,000	3,300,000	2,970,000	3,278,908	3,211,718
Western yellow pine.	2,290,000	1,755,015	1,710,000	1,960,000	1,690,000	1,293,985	1,327,365	1,258,528
Hemlock . . . . .	1,850,000	1,754,998	1,875,000	2,200,000	2,350,000	2,275,000	2,165,728	2,319,982
White pine . . . . .	1,500,000	1,723,642	2,200,000	2,250,000	2,700,000	2,700,000	2,632,587	2,568,636
Maple . . . . .	875,000	857,489	815,000	860,000	975,000	900,000	909,743	901,487
Gum . . . . .	850,000	851,431	765,000	788,000	800,000	655,000	675,380	772,514
Spruce . . . . .	825,000	979,698	1,125,000	1,125,000	1,250,000	1,400,000	1,245,614	1,046,816
Cypress . . . . .	625,000	656,212	630,000	950,000	1,000,000	1,100,000	1,013,013	1,097,247
Redwood . . . . .	476,500	410,442	443,231	487,458	490,850	420,294	535,199	510,271
Chestnut . . . . .	475,000	545,696	400,000	415,000	535,000	490,000	540,591	505,802
Birch . . . . .	405,000	375,079	370,000	415,000	450,000	415,000	430,667	378,739
Larch . . . . .	390,000	388,121	355,000	360,000	455,000	375,000	358,561	395,723
Yellow poplar . . . . .	350,000	328,538	290,000	350,000	560,000	464,000	519,221	620,176
Beech . . . . .	325,000	358,985	290,000	296,000	360,000	360,000	376,464	365,501
Cedar . . . . .	†	332,234	245,000	265,000	410,000	420,000	499,903	358,444
White fir . . . . .	280,000	223,422	213,000	218,200	190,000	125,048	112,627	88,109
Elm . . . . .	225,000	194,417	195,000	205,000	235,000	210,000	214,294	214,532
Basswood . . . . .	195,000	183,562	200,000	203,000	270,000	260,000	264,656	257,102
Tupelo . . . . .	180,000	143,730	237,000	265,000	260,000	170,000	124,480	120,420
Hickory . . . . .	†	170,013	100,000	95,000	125,000	100,000	116,113	162,980
Ash . . . . .	†	154,931	170,000	175,000	210,000	190,000	189,499	207,816
Cottonwood . . . . .	†	144,155	175,000	190,000	200,000	180,000	195,198	208,938
Balsam fir . . . . .	†	68,030	82,000	88,900	125,000	100,000	125,212	93,752
Walnut . . . . .	†	39,218	100,000	62,000	90,000	90,000	25,573	40,565
Sycamore . . . . .	†	28,114	30,000	32,000	40,000	25,000	22,773	30,804
Lodgepole pine . . . . .	†	16,281	12,500	12,500	30,800	26,486	18,374	20,106
Sugar pine . . . . .	†	133,658	111,800	132,600	169,250	117,701	136,159	149,926
Cherry . . . . .	†	†	†	†	†	†	†	†
All Others . . . . .	1,131,300	61,308	60,963	56,117	40,351	47,893	55,624	85,366

\* Preliminary report.

SPECIES, 1899 TO 1920

UNITED STATES BY SPECIES, 1899 TO 1920

Forest Service of the United States Department of Agriculture

1912, M. Ft. Bd. M.	1911, M. Ft. Bd. M.	1910, M. Ft. Bd. M.	1909, M. Ft. Bd. M.	1908, M. Ft. Bd. M.	1907, M. Ft. Bd. M.	1906, M. Ft. Bd. M.	1905, M. Ft. Bd. M.	1904, M. Ft. Bd. M.	1899, M. Ft. Bd. M.
14,732,052	12,896,706	14,143,471	16,277,185	11,236,372	13,215,185	11,661,077	9,760,508	11,521,681	9,657,676
5,175,123	5,054,243	5,203,644	4,856,378	3,675,114	4,748,872	4,969,843	4,319,479	2,928,409	1,736,507
3,318,952	3,098,444	3,522,098	4,414,457	2,771,511	3,718,760	2,816,077	1,833,709	2,902,855	4,438,027
1,219,444	1,330,700	1,562,106	1,499,985	1,275,550	1,527,195	1,386,777	†	1,290,626	945,432
2,426,554	2,555,308	2,836,129	3,051,399	2,530,843	3,373,016	3,508,031	2,804,083	3,268,787	3,420,673
3,138,227	3,230,584	3,352,183	3,900,034	3,344,921	4,192,708	4,582,102	4,983,698	5,332,704	7,742,391
1,020,864	951,667	1,006,637	1,106,604	874,983	939,073	866,862	608,746	587,558	633,466
694,260	582,967	610,208	706,945	589,347	689,200	453,678	316,588	523,990	285,417
1,238,600	1,261,728	1,449,912	1,748,547	1,411,992	1,726,797	1,644,987	1,165,940	1,295,953	1,448,091
997,227	981,527	935,659	955,635	743,297	757,639	839,276	753,369	749,592	495,836
496,796	489,768	543,493	521,630	404,842	569,450	659,678	411,689	519,267	360,167
554,230	529,022	535,049	663,891	539,341	653,239	407,379	224,413	243,537	206,688
388,272	432,571	420,769	452,370	386,367	387,614	370,432	240,704	224,009	132,601
407,064	368,216	382,514	421,214	382,466	211,076	289,473	140,636	31,784	50,619
623,289	659,475	734,926	858,500	654,122	862,849	683,132	582,748	853,554	1,115,242
435,250	403,881	437,325	511,244	410,072	430,005	275,661	219,000	†	†
329,000	374,925	415,039	346,008	272,764	251,002	357,845	363,900	222,994	232,978
122,613	124,307	132,327	89,318	98,120	146,508	104,329	52,725	†	†
262,141	236,108	265,107	347,456	273,845	260,579	224,795	227,038	258,330	456,731
296,717	304,621	344,704	399,151	319,505	381,088	376,838	258,390	228,041	308,069
122,545	98,142	92,071	96,676	69,170	68,842	47,882	35,794	†	†
278,757	240,217	272,252	333,929	197,372	203,211	148,212	95,803	106,824	96,636
234,548	214,398	246,035	291,209	225,367	252,040	214,460	159,634	169,178	269,120
227,477	198,629	220,305	265,600	232,475	293,161	263,996	236,000	321,574	415,124
84,261	83,375	74,580	108,702	69,956	53,339	†	†	†	†
43,083	38,293	36,449	46,108	43,681	41,490	48,174	29,851	31,455	38,681
49,468	42,836	45,063	56,511	43,332	46,044	†	†	†	29,715
22,039	33,014	26,634	23,733	†	†	†	†	†	†
132,416	117,987	103,165	97,191	99,809	115,015	133,640	123,085	†	53,558
†	†	†	24,594	18,054	9,087	†	†	†	†
82,145	69,548	68,428	62,151	29,819	18,647	229,726	555,371	514,463	508,150

† Not reported separately.

## BAND MILL DATA

TABLE XLVI.—BAND MILL DATA\*

Diameter of Wheels (in feet) .....	6	7	7	8	8	9	9	10	10
Greatest distance between guide and base (inches).	44	55	69	55	78	78	65	80	75
Largest log it will slab and cut open (inches) ..	59	78	92	75	104	108	88	110	106
Largest log it will open up through center (inches).	34	46	56	43	60	66	52	63	65
Largest square log it will open through center (inches) .....	28	38	49	34	48	54	48	51	52
Longest saw can use (feet and inches) .....	34-4	41-10½	44-2½	45-3½	48-5½	54-4	51-10	58-5½	58-3
Shortest saw can use (feet and inches) .....	33-6	38-8	39-10	42-1	43-5	51-2	47-4	55-3½	53-10
Standard width of saw (inches) .....	9	10	10	12	14	14	14	14	16
Speed of mill for 10,000 feet, per minute .....	525	450	450	400	400	355	355	320	320
Greatest distance between wheels (inches) .....	22	35½	49½	25½	44½	49½	34	43½	40
Least distance between wheels (inches) .....	14½	14½	21½	4¼	13¼	28	6	22	13
Gauge of saws (usual) .....	17-18	15-16	15-16	14-15	14-15	13-14	13-14	13-14	13-14

\* Refers to band mills manufactured by Clark Brothers Company, Olean, N. Y.

# TIME REQUIRED TO SAW LOGS OF GIVEN DIAMETERS

TABLE XLVII.—TIME REQUIRED TO SAW WESTERN PINE LOGS \*

Diameter of Log.	Number of Logs.	Average Scale.†	Average Tally.	Overrun.	Average Time ‡ per Log.		Average Time, per M. Ft. Bd. M.	
		Ft., Bd. M.	Ft., Bd. M.	Per Cent	Min.	Sec.	Min.	Sec.
6	2	20	47	135.0	1	20	28	21
8	23	30	53	76.6	1	3	19	46
9	53	40	63	57.4	1	5	17	15
10	67	60	79	31.6	1	7	14	8
11	52	70	87	38.6	1	13	14	0
12	52	80	107	33.7	1	23	12	55
13	25	100	127	27.0	1	44	13	38
14	11	110	135	22.7	1	36	11	50
15	17	140	171	22.1	1	59	11	37
16	27	160	197	23.1	1	56	9	44
17	50	180	219	21.7	2	9	9	21
18	44	210	245	16.7	2	21	9	35
19	39	240	263	9.5	2	28	9	48
20	48	280	301	7.5	2	45	9	8
21	42	300	334	10.3	2	53	8	40
22	29	330	378	14.5	3	3	8	4
23	29	380	410	7.9	3	20	8	7
24	43	400	437	9.2	3	32	8	4
25	25	460	476	3.5	3	47	7	56
26	29	500	525	5.0	3	56	7	29
27	41	550	561	2.0	4	13	7	30
28	19	580	614	5.8	4	31	7	21
29	23	610	642	5.2	4	55	7	23
30	17	660	697	5.6	5	7	7	18
31	15	710	719	1.3	5	6	7	5
32	15	740	770	4.0	5	22	6	57
33	10	780	827	4.7	6	2	7	16
34	9	800	876	9.5	6	2	6	22
35	6	880	952	8.2	6	38	6	58
36	4	920	965	4.9	6	57	7	10
37	3	1030	1075	4.4	6	13	5	47
41	1	1270	1236	2.7	9	0	7	17
42	1	1340	1281	4.4	13	0	10	9
Average..	870	290	317	9.3	2	43	8	28

\* From A Study of the Grades of Lumber Produced from California Pine, Fir and Cedar, by Swift Berry, The Timberman, April, 1918, page 39.

† Scribner Decimal C Log Rule.

‡ Sound logs 16 feet long and cut on a band saw.

## SAW GAUGE EQUIVALENTS

TABLE XLVIII.—SAW GAUGE EQUIVALENTS \*

Gauge Number	Approximate Fractional Part of an Inch	Decimal Part of an Inch	Gauge Number	Approximate Fractional Part of an Inch	Decimal Part of an Inch
0	$\frac{2}{64}$ scant	.340	11	$\frac{1}{8}$ scant	.120
1	$\frac{19}{64}$ full	.300	12	$\frac{7}{64}$	.109
2	$\frac{9}{32}$ full	.284	13	$\frac{3}{32}$ full	.095
3	$\frac{17}{64}$ scant	.259	14	$\frac{5}{64}$ full	.083
4	$\frac{15}{64}$ full	.238	15	$\frac{5}{64}$ scant	.072
5	$\frac{7}{32}$ full	.220	16	$\frac{1}{16}$ full	.065
6	$\frac{13}{64}$ scant	.203	17	$\frac{1}{16}$ scant	.058
7	$\frac{3}{16}$ scant	.180	18	$\frac{3}{64}$ full	.049
8	$\frac{11}{64}$ scant	.165	19	$\frac{3}{64}$ scant	.042
9	$\frac{9}{64}$ full	.148	20	$\frac{1}{32}$ full	.035
10	$\frac{1}{8}$ full	.134			

\* Stubbs or Birmingham Gauge.



CIRCULAR SAW SPEEDS AND NUMBER OF TEETH

TABLE XLIX.—CIRCULAR SAW SPEEDS AND NUMBER OF TEETH \*

Rim Speed per Minute	8000 Feet		10,000 Feet		12,000 Feet		Cut-off Saws
	4 Inches and Less		Over 4 Inches and Less than 6 Inches		Over 6 Inches		
Feed per Revolution							
Diameter of Saw, Inches	Revolutions per Minute	Number of Teeth	Revolutions per Minute	Number of Teeth	Revolutions per Minute	Number of Teeth	
48	640	30 or 36	795	36, 44, or 48	.....	.....	80, 90, or 100
50	610	30 or 36	765	40, 44, or 50	.....	.....	80, 90, or 100
52	585	30 or 36	735	44, 48, or 52	.....	.....	80, 90, or 100
54	565	30, 36, or 40	705	44, 50, or 54	.....	.....	90, or 100
56	545	30, 36, or 40	680	50, 56, or 60	820	80 or 90	90, or 100
58	525	36, 40, or 44	660	50, 56, or 60	790	80 or 90	90, 100, or 120
60	510	36, 40, or 44	635	50, 56, or 60	765	80 or 90	100, 120, or 150
62	490	40, 44, or 48	615	62	740	80 or 90	100, 120, or 150
64	475	40, 44, or 48	595	64	715	80 or 90	100, 120, or 150
66	.....	.....	580	66	695	90 or 100	100, 120, or 150
68	.....	.....	560	68	675	90 or 100	120, 144, or 150
70	.....	.....	545	70	655	90 or 100	120, 144, or 150
72	.....	.....	530	72	635	90 or 100	120, 130, or 140

\* From Simonds Guide for Millmen, May, 1916, Vol. VIII, No. 3, page 13.

# THE EVAPORATIVE VALUE OF WOOD FUEL

## TABLE L.—THE EVAPORATIVE VALUE OF WOOD FUEL \*

	Unit	Boiler No. 3		Boiler No. 4	
1. Kind of furnace—Dutch oven.....	Length, ft.	6.5		6.5	
2. Grate surface.....	Sq. ft.	55.25		62.82	
3. Water heating surface....	Sq. ft.	2617		2878	
4. Type of boiler—Sterling water tube.....					
	Unit	Test No. 1	Test No. 2	Test No. 3	Test No. 4
5. Duration.....	Hours	8	4	2.5	2.5
6. Kind of wood fuel.....		Shavings and Hog	Hog Only	Shavings Only	Shavings and Hog
7. Average steam pressure..	Lbs.	131	131	128	100
8. Average temperature of feed water entering boiler.....	°F.	153	145	143	142
9. Temperature of escaping gases.....	°F.	413	427	430	531
10. Forced draught between damper and boiler....	In.	0.2	0.2	0.2	0.2
11. Cubic feet of fuel as fired.	Cu. ft.	3,000	1,055	857	717
12. Average weight of fuel, per cubic foot, as fired.	Lbs.	15.32	18.37	14.64	12.75
13. Per cent of moisture in fuel.....	Per cent	38.5	41.5	34.0	38.5
14. Total weight of water fed to boiler.....	Lbs.	115,390	52,696	30,951	27,998
15. Total units of evaporation	Lbs.	127,469	58,747	34,602	31,311
16. Factor of evaporation....		1.104	1.115	1.120	1.120
17. Cubic feet of fuel consumed per hour.....	Cu. ft.	375	264	343	287
18. Cubic feet per square foot grate surface per hour.	Cu. ft.	3.176	2.236	2.905	2.431
19. Water evaporated per hour.....	Lbs.	14,423	13,174	12,380	11,199
20. Total U. E.† evaporated per hour.....	Lbs.	15,934	14,685	13,841	12,524
21. U. E. per square foot heating surface.....	Lbs.	29.0	26.7	25.2	43.6
22. Boiler horse-power developed.....	H. P.	462	425	401	363
23. Rated capacity in U. E....	Lbs.	19,000	19,000	19,000	9,050
24. Rated boiler horse-power.	H. P.	550	550	550	262
25. Per cent of rated capacity developed.....	Per cent	84	77.2	73.0	138.8
26. Water fed per cubic foot as fired.....	Lbs.	38.46	50.0	36.10	39.0
27. U. E. cubic feet fuel as fired.....	Lbs.	42.50	55.7	40.4	43.6
28. U. E. unit of 200 cubic feet.....	Lbs.	8,500	11,400	8,080	8,720
Cubic feet of fuel per 1000 U. E.....		23.5	17.9	24.8	22.9
B.t.u.'s ‡ per cubic foot, wet.....		84,352	96,497	81,882	84,352
B.t.u.'s per pound, wet....		5,506	5,253	5,593	5,506
B.t.u.'s per pound, dry....		8,953	8,979	8,474	8,953

\* Tests made at the power plant of the St. Paul and Tacoma Lumber Co., Tacoma, Washington, on Feb. 20 and 21, 1917. See West Coast Lumberman, April 1, 1917, page 37.

† U. E. = Unit of Evaporation = 1 pound of water evaporated from and at 212° F.

‡ British thermal unit.

## RELATIVE FIRE HAZARDS OF REFUSE BURNERS

### RELATIVE FIRE HAZARDS OF REFUSE BURNERS \*

#### OPEN-PIT BURNER

##### *Location of Open Pits with Reference to Sawmill*

Under 150 feet add to rate.....	\$2.00
Over 150 feet and under 200 feet add to rate.....	1.50
Over 200 feet and under 300 feet add to rate.....	.1.00
Over 300 feet.....	no charge

##### *Location of Open Pits with Reference to Lumber Yards*

Under 100 feet add.....	300	per cent	of lumber	basis-rate
Over 100 feet and under 200 feet, add.....	240	“	“	“
Over 200 feet and under 300 feet, add.....	180	“	“	“
Over 300 feet and under 400 feet, add.....	120	“	“	“
Over 400 feet and under 500 feet, add.....	60	“	“	“
Over 500 feet.....	no charge			

##### *Location of Open Pit, with 20-foot Fire Wall, with Reference to Sawmill*

Under 300 feet, add to rate.....	\$1.00
Over 300 feet.....	no charge

##### *Location of Open Pits with 20-foot Fire Wall with Reference to Lumber Yards*

Under 100 feet, add.....	250	per cent	of lumber	basis-rate
Over 100 feet and under 200 feet, add.....	200	“	“	“
Over 200 feet and under 300 feet, add.....	150	“	“	“
Over 300 feet and under 400 feet, add.....	100	“	“	“
Over 500 feet.....	no charge			

#### CLOSED BURNER

##### *Location of Closed Burners (Standard) with Reference to Lumber Yards*

Under 50 feet, add.....	60	per cent	of lumber	basis-rate
Over 50 feet and under 100 feet, add.....	40	“	“	“
Over 100 feet and under 150 feet, add.....	20	“	“	“
Over 150 feet.....	no charge			

\* From Cost of Burning Sawmill Refuse, by Rolf Thelen, American Lumberman, April 22, 1916, page 61.

## MATERIAL USED IN THE CONSTRUCTION OF A FRAMED SAWMILL BUILDING

### MATERIAL USED IN THE CONSTRUCTION OF A WOODEN-FRAMED SAWMILL BUILDING TO HOUSE TWO BAND HEAD-SAWS AND AUXILIARY EQUIPMENT

Frame:	
Piers below grade.....	693 cubic feet of concrete
Piers above grade.....	583 cubic feet of concrete
Lumber.....	268,306 bd. ft.
Nails and spikes.....	4,025 lbs.
Log deck:	
Lumber.....	8,934 bd. ft.
Bolts.....	100 lbs.
Nails and spikes.....	134 lbs.
Canopy:	
Lumber.....	2,645 bd. ft.
Nails and spikes.....	40 lbs.
Assorting Platform and Shed 83 feet by 163 feet with 26- by 130-foot shed:	
Rubberoid roofing.....	1,600 sq. ft.
Sheet-iron roofing.....	4,250 sq. ft.
Lumber.....	89,199 bd. ft.
Nails and spikes.....	1,343 lbs.
Concrete piers (small).....	127
Refuse Conveyor Trestle:	
Concrete piers.....	4
Lumber.....	12,705 bd. ft.
Nails and spikes.....	191 lbs.
Bolts.....	124 lbs.
Log Haul Up and Shelter:	
Piling 12-inch by 20 feet.....	8
Lumber.....	9,816 bd. ft.
Rubberoid roofing.....	400 sq. ft.
Nails and spikes.....	1,474 lbs.
Bolts.....	21 lbs.
Windows:	
Ground floor.....	56
Saw floor.....	32
Filing floor.....	24
Monitor.....	12
Doors:	
Ground floor.....	16
SUMMARY	
Lumber.....	409,605 bd. ft.
Rubberoid roofing.....	2,000 sq. ft.
Sheet-iron roofing.....	4,250 sq. ft.
Nails and spikes.....	7,307 lbs.
Bolts.....	245 lbs.
Concrete.....	1,276 cu. yds.
Concrete.....	131 small piers
Piling.....	8 pieces

These figures do not include the materials used in the construction of the lath mill addition and the timber ramp.

## UNDERWOOD-SIMMONS TARIFF ACT—SCHEDULE D

### SYNOPSIS OF THE UNDERWOOD-SIMMONS TARIFF ACT— SCHEDULE D

<i>Article</i>	<i>Import Duty</i>
Timber, hewn, sided or squared otherwise than by sawing (not less than 8 in. square) . . . . .	Free
Sawed boards, planks, deals and other lumber of whitewood, sycamore and basswood . . . . .	“
Sawed lumber not specifically provided for in this section . . . . .	“
Lumber of any sort when planed or finished . . . . .	“
Briar root or briar wood . . . . .	10 Per Cent
Ivy and laurel wood . . . . .	10 “
Sawed boards, planks and deals of Spanish cedar, lignum-vitae, lancewood, ebony, boxwood, granadilla, mahogany, rosewood, satinwood, and all cabinet woods not further manufactured than sawed . . . . .	10 “
Veneers of wood . . . . .	15 “
Wood unmanufactured, not specifically provided for . . . . .	10 “
Paving posts . . . . .	10 “
Railroad ties . . . . .	10 “
Telephone, trolley, electric light and telegraph poles . . . . .	10 “
Casks . . . . .	15 “
Barrels . . . . .	15 “
Hogsheads (empty) . . . . .	15 “
Sugar box shooks . . . . .	15 “
Packing boxes (empty) . . . . .	15 “
Packing box shooks . . . . .	15 “
Boxes containing fruit . . . . .	15 “
Barrels containing fruit . . . . .	15 “
Wood comprising the sides, tops and bottoms of fruit boxes or fruit box shooks, exported and reimported, filled with fruit . . . . .	Free
Toothpicks . . . . .	20 Per Cent
Logs and round unmanufactured timber . . . . .	Free
Pulp woods . . . . .	“
Kindling and fire wood . . . . .	“
Hop poles . . . . .	“
Hoop poles . . . . .	“
Fence posts . . . . .	“
Handle bolts . . . . .	“
Shingle bolts . . . . .	“
Hubs for wheels . . . . .	“
Posts . . . . .	“
Heading bolts . . . . .	“
Stave bolts . . . . .	“
Last blocks . . . . .	“
Wagon blocks . . . . .	“
Oar blocks . . . . .	“
Heading blocks . . . . .	“
Clapboards . . . . .	“

SYNOPSIS OF THE UNDERWOOD-SIMMONS TARIFF ACT—*Continued*

	<i>Article</i>	<i>Import Duty</i>
Lath.....		Free
Pickets.....		“
Palings.....		“
Staves.....		“
Shingles.....		“
Ship timber and planking.....		“
Broom handles.....		“
Sawdust.....		“
Wood flour.....		“
Cedar, including Spanish cedar logs.....		“
Lignum-vitae logs.....		“
Lancewood logs.....		“
Ebony logs.....		“
Boxwood logs.....		“
Granadilla logs.....		“
Mahogany logs.....		“
Rosewood logs.....		“
Satinwood logs.....		“
All other forms of cabinet woods in the log.....		“
Red cedar timber, hewn, sided, squared or round.....		“
Partridge sticks.....		“
Pimento sticks.....		“
Orange sticks.....		“
Myrtle sticks.....		“
Bamboo sticks.....		“
Rattan sticks.....		“
Mechanically-ground wood pulp.....		“
Chemical wood pulp, bleached.....		“
Chemical wood pulp, unbleached.....		“

## INDEX

(Numbers refer to pages. Illustrations are indicated by an asterisk after page number.)

- Accidents, 185  
—, prevention of, 185  
Acts, Workmen's Compensation, 186  
Advertising, lumber, history of, 387  
—, —, trade-marking, 389  
Africa, lumber imports from, 428  
Air-drying, depreciation of lumber during, 244  
Air-seasoning, 205  
—, end checking, prevention of, 216  
—, pile foundations, 208, 209\*  
—, — roofs, 213, 214\*  
—, piling methods, 209  
—, pole-stacking, 214  
—, runways, 205, 207\*  
—, shed, 215, 215\*  
— storage, shed, 216  
—, time required for, 217  
—, — — —, Douglas fir, 218  
—, — — —, southern yellow pine, 218  
—, use of salt in, 217  
—, yard location, 205  
—, — sanitation, 222  
Air-velocity, dust-collecting system, 261  
Alabama Lumber Co., Ltd., 315  
Alabama, lumber production in, 506  
—, wood-using industries of, 446  
American Hardwood Manufacturers' Association, 310, 317, 344  
— — — —, legal proceedings against, 338  
American Lumber Trades Congress, 321  
American Oak Manufacturers' Association, 359  
Appalachians, portable sawmills in, 4  
—, use of drag cars at sawmills in, 33  
Appraisal, plant, 301  
Argentina, lumber markets in, 420  
Arizona, lumber production in, 506  
Arkansas, lumber production in, 506  
—, wood-using industries of, 446\*  
Arkansas and Missouri Yellow Pine Co., 315  
Ash, exports to Argentina, 420  
—, — — Holland, 413  
—, — — Italy, 413  
—, — — Mexico, 419  
—, — — Peru, 423  
—, — — United Kingdom, 416  
—, lumber production of, 508  
Asia, lumber, exports to, 1913-1920, 402  
—, —, imports from, 428  
Asiatic markets, lumber, 424  
Associated Bureau of Grades, West Coast Lumbermen's Association, 361  
Associations, activities, early manufacturers, 313  
—, —, — —, Mississippi Valley Lumbermen's Association, 316, 317  
—, —, — —, National Hardwood Lumber Association, 317  
—, —, — —, Northwestern Lumber Manufacturers' Association, 313  
—, —, — —, Southern Lumber Manufacturers' Association, 314, 316, 317  
—, —, recent manufacturers, 317  
—, legal proceedings against, 327  
—, — — —, American Hardwood Manufacturers' Association, 338  
—, — — —, Eastern States Retail Lumber Dealers' Association, 334  
—, — — —, Mississippi Valley Lumbermen's Association, 327  
—, — — —, Nebraska Lumber Dealers' Association, 328  
—, — — —, Northwestern Lumbermen's Association, 327, 336  
—, — — —, Retail Lumber Dealers' Association of Mississippi and Louisiana, 329

- Associations, legal proceedings against,  
Southern Pine Association, 341
- , —, —, Toledo (Ohio) Retailers, 333
- , —, —, West Coast Lumbermen's Association, 342
- , —, —, Western Pine Manufacturers' Association, 343
- , —, —, Yellow Pine Manufacturers' Association, 331
- , lumber trade, 305
- , —, —, character, 305
- , —, —, legal proceedings against, 327
- , —, —, manufacturers, 305
- , —, —, —, activities, early, 313
- , —, —, —, recent, 317
- , —, —, retail, 318
- , —, —, wholesale, 322
- , manufacturers', 305
- , —, California sugar and white pine, 311
- , —, cypress, 307
- , —, hardwoods, 309, 311
- , —, hemlock and hardwoods, 311
- , —, Inland Empire, 311
- , —, National Lumber Manufacturers' Association, 312
- , —, North Carolina pine, 307
- , —, redwood, 312
- , —, southern yellow pine, 306
- , —, The Hardwood Manufacturers' Institute, 344
- , —, West Coast, 309
- , —, white pine, 308
- , retail, Colorado and Wyoming Lumber Dealers' Association, 322
- , —, Eastern States Lumber Dealers' Association, 321, 334
- , —, Illinois Lumber and Builders' Supply Dealers' Association, 319
- , —, Iowa Retail Lumber Dealers' Association, 318
- , —, Lumber Secretaries' Association, 320, 321
- , —, Lumber Secretaries' Bureau of Information, 321
- , —, Michigan Retail Lumber Dealers' Association, 322
- , —, National Retail Lumber Dealers' Association, 319
- Associations, retail, lumber trade, New York Lumber Trade Association, 319
- , —, Northwestern Lumbermen's Association, 319, 322
- , —, objects of, 319
- , —, Retail Lumber Dealers' Association of Mississippi and Louisiana, 322
- , —, Retail Lumber Secretaries' Association, 321, 322
- , —, United Association of Lumbermen, 320
- , —, universal constitution of, 320
- , —, wholesale, 322
- , —, American Wholesale Lumber Association, 325
- , —, Cleveland Board of Lumber Dealers', 323
- , —, Lumber Exchange of Baltimore, 323
- , —, Lumbermen's Association of Chicago, 323
- , —, National Bureau of Wholesale Lumber Distributors, 325
- , —, National Hardwood Lumber Association, 309, 325, 429
- , —, National Wholesale Lumber Dealers' Association, 323
- , —, Pacific Coast Shippers' Association, 325
- Assorter, Hanson lumber, 138, 138\*
- Assorting lumber, green, 136
- , —, —, assorting table, 136
- , —, —, edge sorter, 137, 138\*
- , —, —, Hanson assorter, 138, 138\*
- Atlantic Coast Cypress Association, 308
- Australia, lumber market in, 425
- Band mill, data, 510
- , —, double-cutting, 86, 87\*
- , —, —, horizontal, 88, 88\*
- , —, —, log-stop and loader for, 86, 86\*
- , —, —, single-cutting, 83, 83\*
- Band saw, head saws, 122
- , —, resaws, 127
- , —, yield from logs cut by, 282
- Barges, transportation of lumber in, 376
- Bark, air-velocity required to move, 261
- , uses for, 281
- Barrels, water, and buckets, 294
- Basswood, import duty on, 428





- Carriage, sawmill, cable feed, 72, 72\* 73\*  
 —, —, feed, 69  
 —, —, —, cable, 72, 72\* 73\*  
 —, —, —, rack-and-pinion, 69, 69\*  
 —, —, —, steam, 73, 74\*  
 —, —, framework, 52, 53\*, 54  
 —, —, friction drive, 69, 70\*  
 —, —, gig-back, 71\*  
 —, —, head-blocks, 56, 57\*  
 —, —, —, dogs, 58, 58\* 59\*, 60\*, 61\*  
 —, —, —, knees, 57\*, 58, 58\*  
 —, —, —, number of, 57  
 —, —, —, spacing, 57  
 —, —, off-set, 61, 62\*  
 —, —, parts of, 52  
 —, —, rails, 55, 55\*  
 —, —, receding mechanism, 53\*, 65, 65\*  
 —, —, set-works, 62, 63\*, 64\*, 66\*, 67\*  
 —, —, —, dial, 64, 65\*  
 —, —, three-block, 53\*  
 —, —, track-cleaning device, 56, 56\*  
 —, —, trailer, 54, 55\*  
 —, —, trucks, 53\*, 55  
 Carrier, lumber, surface, 144, 144\*  
 —, —, —, bolsters for, 145, 145\*  
 Cars, small rail, for handling lumber, 154  
 Catamarans, log-raising, 20  
 Cedar, incense, grades produced from, 487  
 —, —, lumber production of, 508  
 —, Port Orford, grading rules for, 358  
 —, southern white, grading of, 358  
 —, western red, grading rules for, 358  
 —, —, —, manufacture of shingles from, 267  
 Central America, lumber, exports to, 1913-1920, 402  
 — —, —, imports from, 429  
 Central States, sawmills in, xvii  
 Chain, box or drag, 166\*, 167  
 —, flat-link, 135, 135\*  
 —, Heald No. 74, 134, 134\*  
 —, jack, and log dogs, 32, 32\*  
 —, lumber handling, 133, 152  
 —, refuse conveyor, 134, 134\*  
 —, roof-top or hog-back, 133, 133\*  
 —, transfer, 134, 134\*  
 Cherry, exports of, to Germany, 411  
 —, —, lumber production of, 508  
 Chestnut, lath manufacture from, 287  
 —, —, lumber production of, 508  
 Chile, lumber market in, 422  
 China, lumber market in, 424  
 Chips, air-velocity required to move, 261  
 Circular mill, double, 79, 79\*  
 — —, single, 78, 78\*  
 — saws, yield from logs cut by, 282  
 Classification, lumber products, rail transportation, 369  
 —, — —, — —, Esch proposed, 271  
 —, — —, — —, Central Freight Association proposed, 369  
 —, trade, retail associations, 324  
 Cleanliness, fire prevention, 292  
 Colorado, lumber production in, 506  
 Colorado and Wyoming Lumber Dealers' Association, 322  
 Columbia river, log lifts used along, 34  
 Companies, fire, sawmill plants, 299  
 Compartment dry kilns, 228  
 Concrete, foundations, lumber pile, 208, 209\*  
 —, —, sawmill building, 22  
 Congress, American Lumber Trade, 321  
 Connecticut, lumber production of, 506  
 —, wood-using industries of, 447  
 Construction, improper sawmill, as a cause of fires, 292  
 Consumption, lumber, changes in, by decades, 393, 393\*  
 —, —, — —, per capita, 393  
 —, —, — —, regional, 394  
 Conveyors, belt, 135  
 —, fuel, 164\* 166, 166\*  
 —, horse-power, 162  
 Cottonwood, exports of, 413, 414  
 —, —, lumber production of, 508  
 —, —, manufacture of box shooks from, 267  
 Cranes, cantilever, 148, 149\*  
 —, Gantry, 150, 150\*  
 —, locomotive, log handling, 15, 16\*  
 —, —, lumber handling, 151  
 Cuba, lumber market in, 423  
 Customs districts, lumber entering, 429  
 Cut-off saws, band, 41  
 — —, circular, 39, 40\*, 256, 257\*  
 Cyclone, dust-collecting system, 262, 262\*  
 Cypress, exports of, 415  
 —, —, grading rules, 357  
 —, —, lumber production of, 508  
 —, —, manufacturers' associations, 307  
 —, — —, Atlantic Coast Cypress Association, 308

- Cypress, manufacturers' associations,  
     Southern Cypress Lumber  
     Association, 308  
 —, —, Southern Cypress Lumber Sell-  
     ing Co., Ltd., 308  
 —, —, Southern Cypress Lumber and  
     Shingle Association, 308  
 —, —, Southern Cypress Manufac-  
     turers' Association, 308  
 —, —, Teche and Gulf Coast Cypress  
     and Shingle Association, 307  
 —, markets for, 398  
 —, stocks at mills, 275
- Data, band mill, 510  
 Deals, exports of, 402  
 —, imports of, 427  
 Deck, sawmill, 42, 45\*  
 Delaware, lumber production in, 506  
 Density rule, adoption of, 347  
 Department stores, sale of lumber by, 387  
 Depreciation, lumber, during seasoning,  
     244  
 Derrick, log storage, 28  
 Dial, set works, 64, 65\*  
 Dingley Tariff Act, 428, 432, 437  
 Dipping lumber, 220  
 —, objections to, 221  
 —, tank for, 220, 221\*  
 Distribution, lumber, 389  
 Docks, timber, 139, 139\*  
 Dog board, 58  
 Dogs, carriage, 57\*, 58, 58\*, 59\*, 60\*  
 —, —, boss, 58, 58\*  
 —, —, duplex, 60, 60\*  
 —, —, hammer, 58, 59\*  
 —, —, hook, 60, 61\*  
 —, —, quartering, 59, 59\*  
 —, —, single-tooth, 60, 60\*  
 —, —, spud dog, 60, 61\*  
 —, deck, 40, 41, 41\*, 42\*  
 Doors, dry kiln, 230\*, 235  
 —, —, carriers for, 230\*, 235  
 Douglas fir, depreciation of, during sea-  
     soning, 247  
 —, exports, 401  
 —, —, Argentina, 420  
 —, —, Australia, 425  
 —, —, Canada, 418  
 —, —, Chile, 422  
 —, —, China, 424  
 —, —, Germany, 411  
 Douglas fir, exports, Holland, 413  
 —, —, Italy, 413  
 —, —, Japan, 425  
 —, —, Mexico, 419  
 —, —, Peru, 423  
 —, —, Spain, 415  
 —, —, United Kingdom, 416  
 —, —, grades produced from, 485, 486  
 —, —, grading rules for, 354  
 —, —, imports of, 428  
 —, —, lumber production of, 508  
 —, —, manufacture of timbers from, 266  
 —, —, time required to air-season, 218  
 Draft, forced, for saw mill power, 165, 166\*  
 Drag car, sawmill, 33  
 Drag saws, deck, circular, 39, 39\*  
 —, —, marine, 37, 38\*  
 —, —, walking-beam, 39, 39\*  
 Drive, sawmill carriage, belt feed for, 70,  
     71\*  
 —, —, friction, 69, 70\*  
 —, —, steam, 73, 74\*  
 Drums, mud, 166  
 Dry-air kilns, furnace, 229  
 —, —, smoke, 229  
 Dry kilns, capacity, 243  
 —, —, classification, 227  
 —, —, compartment, 228  
 —, —, development of, 224  
 —, —, dry-air, 227, 229  
 —, —, equipment, 235  
 —, —, loading trucks for, 240  
 —, —, moist air, 227, 230\*  
 —, —, progressive, 228, 230\*  
 —, —, super-heated steam, 227, 234  
 —, —, Tiemann, 232, 233\*  
 —, —, unloading kiln trucks, 242  
 Dust-collecting system, planing mill, 258  
 —, —, air pressure, 261, 262  
 —, —, air-velocity, 261  
 —, —, cyclone, 258, 262\*  
 —, —, fan, 258, 258\*, 261  
 —, —, pipes, 259  
 —, —, suction force, 260  
 Dutch-oven, boiler setting, 164, 164\*  
 Eastern States Retail Lumber Dealers'  
     Association, 321, 334  
 —————, legal proceedings  
     against, 334  
 Eastern Washington and Northern Idaho  
     lumbermen's Association, 311

- Edger, 98, 99\*, 101\*  
 —, double-gang, 98, 99\*  
 —, feed rolls, 101, 101\*  
 —, saw guide, 99, 100\*  
 —, saws, 99  
 —, single-gang, 98, 101\*  
 Edge sorter, 137, 138\*  
 Edging, lumber, 98  
 —, problems of, 199  
 —, strips, volume of, log conversion, 283  
 Efficiency, labor, 177  
 —, —, measurement of, 177, 178\*  
 Electric drive, planing mills, 263  
 — —, sawmills, 37, 68, 161  
 Elevation of logs, to sawing floor, 24  
 — — —, — — —, from land storage, 26  
 — — —, — — —, from water storage, 30  
 Elm, lumber production of, 508  
 Empire State Forest Products Association, 310  
 Employment, problems of, 182  
 End-checking, lumber, prevention of, 216, 216\*  
 Endless chain and jacker, 28  
 Engines, sawmill, 158, 160  
 Equipment, auxiliary, for fire control, 297  
 —, dry kiln, boiler feed pump, 239  
 —, — —, doors, 230\*, 235  
 —, — —, instruments for measuring temperature and humidity, 239  
 —, — —, steam traps, 237, 237\*, 238\*  
 —, — —, trucks, 235, 236\*  
 —, lumber handling and transfer, 130  
 —, — — — —, belt conveyors, 135  
 —, — — — —, chains, 133  
 —, — — — —, rollers, 130  
 —, — — — —, transfers and trips, 132, 132\*, 133\*  
 Equivalent, saw gauge, 512  
 Ethics, code of, lumber trade, 321  
 Europe, lumber exports to, 1913–1920, 402  
 Exchange, sales, 382  
 Exhaust system, planing mill, 257, 258\*, 262\*  
 Export trade, lumber, cooperation in, 408  
 — —, —, 1913, 401  
 — —, —, 1913–1920, 402, 403  
 — —, —, 1920, 403  
 — —, —, methods, 405  
 Extinguishers, chemical, 295  
 Fan, exhaust, planing mill, 258, 258\*, 261  
 Farmer's stock companies, lumber sales by, 386  
 Feed, roller, edger, 100, 101\*  
 —, sawmill, belt and friction, 70, 71\*  
 —, —, cable, 72, 72\*, 73\*  
 —, —, friction, 69, 70\*  
 —, —, rack-and-pinion, 69, 69\*  
 —, —, steam, 73, 74\*  
 Filing room machinery, 121, 127, 129, 265  
 Fir, balsam, lumber production of, 508  
 —, —, yield of laths, per cord, 287  
 —, Douglas, depreciation of, during seasoning, 247  
 —, —, exports of, 401, 411, 413, 414, 415, 416, 419, 420, 422, 423, 424, 425  
 —, —, grades produced from, 485, 486  
 —, —, grading rules for, 354  
 —, —, imports of, 428  
 —, —, lumber production of, 508  
 —, —, manufacture of timbers from, 266  
 —, —, tooth patterns for, band, 123  
 —, —, — — —, circular, 117  
 —, red, grades produced from, 486  
 —, white, grades produced from, 486  
 —, —, lumber production of, 508  
 Fire, causes of, sawmill, 291  
 —, cleanliness, 292  
 —, control, 294  
 —, detection, 293  
 —, fire-proofing, 293  
 —, insurance, 299  
 —, lumber values, 301  
 —, plant appraisal, 301  
 Fire-proofing structures, 293  
 Fire retardants, 295  
 Floating sawmills, 4  
 Flooring, southern yellow pine, 268  
 Florida, lumber production of, 506  
 —, wood-using industries of, 447  
 Forced draft, power-house equipment for, 165, 166\*  
 Forest Products Exposition, 388  
 Foundations, lumber pile, concrete, 208, 209\*  
 —, — —, poorly constructed, 223\*  
 —, sawmill building, concrete, 22  
 —, — —, damage from settling, 22  
 —, — —, piles for, 22  
 —, — —, size, 24

- Framework, sawmill carriage, 52, 53\*, 54  
 France, lumber market in, 410  
 Freight rates, rail, 367  
   —, —, basis of payment, 367  
   —, —, blanket areas, 367  
   —, —, local, 368  
   —, —, through, 367  
 Friction, cause of sawmill fires, 291  
 Fuel, conveyors, 164\*, 166  
   —, use of refuse for, 285  
   —, wood, evaporative value of, 514  
 Furnace kiln, 229
- Gang mill, circular, 96, 96\*  
   —, sash, 89, 90\*  
 Gauge, saw, equivalents, 512  
 Georgia, grading and inspecting white  
   pine in, 352  
   —, lumber production in, 506  
   —, state rules for grading lumber, 348  
   —, wood-using industries of, 448  
 Georgia-Florida Saw Mill Association,  
   Inc., 307  
   — — — —, grading rules of, 351  
 Georgia Interstate Saw Mill Association,  
   307  
 Georgia Saw Mill Association, 307, 351  
 Germany, lumber market in, 410  
 Gig-back, friction, 70, 71\*  
 Glossary, lumber terms, 449  
 Grades, lumber, per cent produced, 272  
   —, —, produced from, 484  
   —, —, —, cedar, incense, 487  
   —, —, —, —, western red, 487  
   —, —, —, fir, Douglas, 485, 486, 487  
   —, —, —, —, red, 486  
   —, —, —, —, white, 486, 487  
   —, —, —, gum, red, 491  
   —, —, —, hardwoods, 490  
   —, —, —, hemlock, eastern, 486  
   —, —, —, larch, western, 487  
   —, —, —, oak, red, 489  
   —, —, —, —, southern, 490  
   —, —, —, —, white, 488  
   —, —, —, pine, Idaho, white, 487  
   —, —, —, —, southern yellow, 484  
   —, —, —, —, sugar, 485  
   —, —, —, —, western yellow, 484,  
     485, 497  
   —, —, uniform, adoption of, 317  
 Grades and inspection, basis of rules for,  
   346
- Grades and inspection, bibliography, 441  
   — — —, enforcement of rules for, 360  
   — — —, formulation of rules for, 345  
   — — —, objects of, 345  
 Grading rules, necessity for, 349  
   —, cedar, Port Orford, 358  
   —, —, southern white, 358  
   —, —, western red, 358  
   —, —, cypress, 357  
   —, fir, Douglas, 354  
   —, hardwoods, 358  
   —, hemlock, eastern, 355  
   —, —, western, 356  
   —, larch, tamarack, 357  
   —, —, western, 357  
   —, pine, eastern white, 352  
   —, —, lodgepole, 354  
   —, —, Norway, 354  
   —, —, southern yellow, 350  
   —, —, sugar, 354  
   —, —, western white, 353  
   —, —, western yellow, 353  
   —, redwood, 358  
   —, spruce, eastern, 356  
   —, —, Sitka, 356  
 Grate bars, 165, 165\*  
 Grinders, refuse, 108, 108\*  
 Grit, removal of, from logs, 35, 36\*, 97,  
   97\*  
 Gulf Coast Yellow Pine Export and Man-  
   ufacturers' Association, 351  
 Gum, exports of, 403, 413  
   —, lumber production of, 508  
   —, red, grades produced, 491  
   —, —, quarter-sawing, 198, 198\*  
 Gum Lumber Manufacturers' Associa-  
   tion, 359
- Handling lumber, bibliography, 441  
 Hardwoods, defective, sawing, 194, 194\*  
   —, grades produced, 488, 490, 491, 492  
   —, grading rules for, 358  
   —, manufacture, lath from, 267  
   —, —, timbers from, 266  
   —, manufacturer's associations, 309  
   —, —, Adirondack Lumber Manu-  
     facturers' and Shippers' Asso-  
     ciation, 310  
   —, —, American Hardwood Manu-  
     facturers' Association, 310  
   —, —, Empire State Forest Products  
     Association, 310

- Hardwoods, manufacturers' associations,  
 Hardwood Manufacturers' Association of the United States, 310
- , —, —, Michigan Hardwood Manufacturers' Association, 310
- , —, —, Mississippi Valley Hardwood Lumber Manufacturers' Association, 309
- , —, —, National Association of Hardwood Lumber Manufacturers', 309
- , —, —, Northern Hemlock and Hardwood Manufacturers' Association, 311
- , —, —, The Hardwood Manufacturers' Institute, 344
- , —, —, Wisconsin Hardwood Lumbermen's Association, 311
- , markets, lumber, 395
- , mills, stocks at, 275
- , tooth patterns, saw, band, 123\*
- , —, —, circular, 117\*
- , uses of, 346
- Hardwood Manufacturers' Association of the United States, 195, 310
- Haul-up car, 27\*
- Head-block, 56, 57\*, 59\*, 61\*
- Head-saw, band, 81
- , —, double-cutting, 85, 87\*
- , —, pony, 85
- , —, self-contained, 88, 88\*
- , —, single-cutting, 83, 83\*
- , —, twin, 87
- , circular, breaking-down, 81, 81\*
- , —, double, 78, 79\*
- , —, single, 78, 78\*
- , —, twin-circular, 80, 80\*
- Heaters, water, 166
- Hemlock, eastern, grades produced from, 486
- , —, grading rules for, 355
- , —, imports of, 428
- , —, lumber production of, 508
- , —, slab-wood for pulp, 289
- , —, tooth patterns, band saw, for, 123\*
- , manufacturers' associations, Northern Hemlock and Hardwood Manufacturers' Association, 311
- , —, —, Northwestern Hemlock Manufacturers' Association, 311
- Hemlock, western, grading rules for, 356
- , —, lumber production of, 508
- , —, sawdust, value as fuel, 285
- Hickory, exports, 411, 413, 414, 415, 416
- , lumber production of, 508
- Holland, lumber market in, 412
- Hollow-back, 272
- Hook, saw, band, 122, 123\*
- , —, circular, 116, 116\*
- Horse-power, planing mills, 265
- , sawmills, 162
- Hose, houses for, 296
- , linen, 296
- , nozzles for, 296
- , rubber-lined, 296
- Hot pond, 18, 19\*
- Hours, one-man, required to produce lumber, 177, 178\*, 180
- Housing and social welfare, 172
- Humboldt Lumber Manufacturers' Association, grading rules of, 358
- Humidity, lumber seasoning, control of, 217, 229, 231, 232
- Hydrants, 295
- Idaho, lumber production of, 506
- , wood-using industries of, 446
- Illinois, lumber production of, 506
- , wood-using industries of, 447
- Imports, logs and lumber, 1913-1920, 427
- , logs, lumber and shingles, 437\*
- , lumber, 427
- Indiana, lumber production of, 506
- , wood-using industries of, 447
- Industries, wood-using, bibliography, by states, 446
- Inland Empire, grades produced in, 487
- , —, labor, 171, 172, 183, 184
- , —, lumber produced in, 275
- , —, manufacturers' associations, 311
- , —, —, Eastern Washington and Northern Idaho Lumbermen's Association, 311
- , —, —, Western Pine Manufacturers' Association, 311
- , —, —, Western Pine Shippers' Association, 311
- , —, markets for, 400
- , —, sawmills, number of, xvii
- Inspection, lumber, rules for, 345
- , lumber grades, bibliography, 441

- Inspection service, 361  
 Institute, the Hardwood Manufacturers', 344  
 Instruments, humidity and temperature recording, 239  
 Insurance, mutual, 299  
 —, mutual-underwriting, 300  
 —, self, 301  
 —, stock company, 299  
 Interstate Rules, 350  
 Inventories, lumber, periodic, 276  
 —, —, perpetual, 276, 278  
 Inventory systems, lumber, bibliography, 441  
 Iowa, lumber production of, 506  
 —, wood-using industries of, 447  
 Italy, lumber, market in, 413
- Jack chain, 30, 31\*, 32\*  
 Jack, lumber, 212, 212\*  
 Japan, lumber market in, 425  
 Jets, stream, use in fire control, 298
- Kansas, lumber production of, 506  
 Kentucky, lumber production of, 506  
 —, wood-using industries of, 447  
 Kerf, saws, band, 77, 282  
 —, —, circular, 77, 282  
 —, —, rock, 98  
 Kicker, log, 44, 45\*, 46\*  
 Kiln drying, depreciation of lumber during, 246  
 Knee, sawmill carriage, 57\*, 58, 58\*, 59\*, 60\*, 61\*
- Labor, bibliography, 441  
 —, efficiency, 177  
 —, hours of, 181  
 —, lumber industry, 171  
 —, —, accident prevention, 185  
 —, —, character, 171  
 —, —, housing and social welfare, 172  
 —, —, manner of employment, 182  
 —, —, sawmill, occupations, 181  
 —, —, —, organization, 181  
 —, —, unions, 183  
 —, —, wage earners, 171  
 —, —, wages and efficiency, 173  
 —, —, workmen's compensation acts, 186
- Lake States, hot ponds in, 18, 19\*  
 —, —, labor problems, 171, 172, 184
- Lake States, lumber, markets, 397  
 — — —, production, 275  
 — —, sawmills in, xvii  
 — —, use of sash-gang in, 91  
 Land storage, logs, 12  
 Larch, eastern, see Tamarack.  
 —, western, grading rules for, 357  
 —, —, lumber production of, 508  
 Laths, conversion factor, to board feet, 288  
 —, imports, 428  
 —, production of, 506  
 —, size, 287  
 —, source, 267  
 —, use of mill refuse for, 286  
 Lengths, sawed products, 269  
 Lighting system, sawmill plants, 163  
 Line yards, retail trade, 385  
 Locomotive, cranes for assorting and decking logs, 15, 16\*  
 —, electric, for hauling lumber, 155, 156\*  
 Log-assorting devices, portable, 15  
 — —, stationary, 14  
 Log buggy, for elevating logs to sawing floor, 34  
 — car, for elevating logs to sawing floor, 29, 29\*  
 — conversion, loss of volume in, 280  
 — —, products of, 281  
 — —, — —, bark, 281  
 — —, — —, edging strips, 283  
 — —, — —, sawdust, 281  
 — —, — —, shavings, 284  
 — —, — —, slabs, 282  
 — —, — —, trimmings, 284  
 — deck, 42, 45\*  
 — —, framework, 44  
 — —, pitch, 44  
 — —, size, 44  
 — haul-up, 30, 31\*  
 — jack, 32, 162  
 — kicker, 44, 45\*, 46, 46\*  
 — stop and loader, 45\*, 47  
 — — — —, for double-cutting band, 86, 86\*  
 — storage, 12  
 — —, land, 12  
 — —, water, 16  
 — transfer, 46  
 — turning devices, 48  
 — — —, friction nigger, 50  
 — — —, overhead turner, 48

- Log turning devices, Simonson, 49  
 — — —, steam nigger, 52  
 — unloader and stacker, 15  
 — washing equipment, 35, 36\*
- Logs, cableway system for assorting and piling, 13, 13\*  
 —, cross-cutting, 36  
 —, export of, 403  
 —, — —, to Belgium, 409  
 —, — —, — Canada, 418  
 —, — —, — France, 410  
 —, — —, — Germany, 411  
 —, — —, — Holland, 413  
 —, — —, — Mexico, 419  
 —, — —, — United Kingdom, 416  
 —, hardwood, method of sawing, 194, 194\*, 195, 195\*, 196\*  
 — imports, 427, 437\*  
 —, —, volume of, 428  
 —, knotty, method of sawing, 193, 194\*  
 —, time required to saw, 511  
 —, unloading from cars, 17  
 —, washing of, 35, 36\*
- Louisiana Red Cypress Co., 382  
 Louisiana, lumber production in, 506  
 —, wood-using industries of, 447
- Lumber, advertising, 387  
 —, careless piling of, 223\*  
 —, consumption, 393, 393\*  
 —, distribution, 389  
 —, edging, 199  
 —, grades, 484  
 —, grades and inspection, 345  
 —, — — —, enforcement of rules for, 360  
 —, — — —, formulation of rules for, 345  
 —, — — —, private and association rules for, 349  
 —, — — —, state rules for, 348  
 —, handling, bibliography, 441  
 —, hardwood, weights of, 496  
 —, imports, 427, 437\*  
 —, manufacture, bibliography, 442  
 —, —, development of, xv  
 —, markets, 395  
 —, —, hardwood, 395  
 —, —, softwood, 395  
 —, merchandising, bibliography, 442  
 —, moisture content of, 204, 218  
 — plant, manufacturing, 3, 10\*, 26\*  
 — prices, bibliography, 443  
 — process, manufacturing, xvii
- Lumber production, 392  
 — —, by decades, xvi\*  
 — —, species, 1899-1920, 508  
 — —, states, 1879-1920, 506  
 —, re-manufacture of, 248  
 —, rough sawed, import duty on, 428  
 — rules, for grading and inspection, private and association, 349  
 — — — — —, state, 348  
 —, seasoned, how to measure conditions in, 505  
 —, seasoning, air, 205  
 —, —, bibliography, 444  
 —, —, depreciation of lumber in, 244  
 —, —, dry kilns for, 224  
 —, —, effect of, on weight, 247  
 —. —. reasons for, 204  
 —, sizes of, 497  
 —, — —, cedar, 500  
 —, — —, cypress, 501  
 —, — —, fir, Douglas, 500  
 —, — —, hardwoods, 502, 504  
 —, — —, hemlock, western, 500  
 —, — —, pine, eastern white, 499  
 —, — —, —, North Carolina, 498  
 —, — —, —, southern yellow, 497  
 —, — —, spruce, eastern, 502  
 —, — —, —, Sitka, 500  
 — tariff, 429  
 —, trade-marking of, 389  
 — transportation, bibliography, 443  
 — trust investigation, 329  
 — values, 301  
 —, weight of, 226, 493, 495
- Lumber industry, economic studies of, bibliography, 439  
 — —, history of, bibliography, 440
- Lumber Manufacturers' Association of the Northwest, 309
- Lumber Secretaries' Association, 320
- Lumber Secretaries' Bureau of Information, 321  
 — — — — —, legal proceedings against, 335
- Machinery, bibliography, sawmill, 443  
 —, —, wood-working, 448
- Mail-order house, sale of lumber by, 386
- Maine, lumber production of, 506  
 —, rules, state, for grading lumber, 348  
 —, wood-using industries of, 447



- Mains, water, and hydrants, 295  
 Manufacture, lumber, bibliography, 442  
 —, —, waste in, bibliography, 446  
 Maple, grades produced from, 492  
 —, hard, exports of, 411, 414, 415, 419  
 —, mill scale studies of, 274, 492  
 —, production, lumber, 508  
 Maritime provinces, Canada, wood-  
 using industries of, 447  
 Markets, lumber, domestic, 380  
 —, —, —, distribution, 389  
 —, —, —, methods of sale, 380  
 —, —, foreign, 401  
 —, —, —, early, 401  
 —, —, —, European, 409  
 —, —, —, export, methods, 405  
 —, —, —, —, trade cooperation in, 408  
 —, —, —, North American, 418  
 —, —, —, Oceania, 425  
 —, —, —, South American, 420  
 —, —, —, volume of, 401  
 —, —, —, West Indian, 423  
 —, —, hardwood, 395  
 —, —, softwood, 395  
 Maryland, lumber production of, 506  
 —, wood-using industries of, 446  
 Massachusetts, lumber production of, 506  
 —, wood-using industries of, 447  
 Mather, planer- and-, 252  
 McKinley Tariff Act, 431, 437\*  
 Meginn rules, inspection white pine, 352  
 Merchandising lumber, bibliography, 442  
 Mexico, lumber market in, 419  
 Michigan, lumber production of, 506  
 —, wood-using industries in, 447  
 Michigan Hardwood Manufacturers' As-  
 sociation, 310  
 Michigan Retail Lumber Dealers' Asso-  
 ciation, 322  
 Milling-in-transit, advantages of, 371  
 —, assessment of freight charges on, 372  
 Mill products, bundling of, 272  
 — refuse and its disposal, 279  
 — — — — —, loss of volume in log  
 conversion, 280  
 — — — — —, merchantable volume of  
 a tree, 279  
 — — — — —, refuse disposal, 285  
 — — — — —, uses for, 279  
 — scale studies, 274  
 — — — — —, bibliography, 443  
 Minnesota, lumber production in, 506  
 Minnesota, wood-using industries of, 447  
 Minnesota Transfer, 373  
 Mississippi, lumber production in, 506  
 —, wood-using industries of, 446  
 Mississippi Valley Hardwood Lumber  
 Manufacturers' Association, 309  
 Mississippi Valley Lumbermen's Asso-  
 ciation, 308  
 — — — — —, legal proceedings against,  
 327  
 Missouri, lumber production in, 506  
 —, wood-using industries of, 446  
 Missouri and Arkansas Yellow Pine Asso-  
 ciation, 305  
 Moist-air kilns, 230  
 — —, condensing, 232  
 — —, forced draft, or blower, 232  
 — —, humidity-regulated, steam-spray,  
 234  
 — —, —, water-spray, 232  
 — —, oven or boiling, 234  
 — —, ventilated, 230  
 Molder, inside, 254, 265  
 —, outside, 254, 265  
 Molding books, standard, 266, 271  
 — machine, 253, 265  
 —, manufacture of, 283  
 Monorail, log, 14  
 —, lumber, 145, 146\*, 148\*  
 Montana, lumber production in, 506  
 —, wood-using industries of, 446  
 Morrill Tariff Act, 431, 437\*  
 Motor truck transportation, lumber, 374  
 Mutual Lumber Company of Mississippi  
 and Louisiana, 315  
  
 National Association of Hardwood Lum-  
 ber Manufacturers, 309  
 National Bureau of Wholesale Lumber  
 Distributors, 384  
 National Hardwood Lumber Association,  
 309, 429  
 National Lumber Manufacturers' Asso-  
 ciation, 312, 321  
 — — — — —, trade extension, 388  
 National Retail Lumber Dealers' Asso-  
 ciation, 319, 322  
 Nebraska, lumber production in, 506  
 Nebraska Lumber Dealers' Association,  
 322  
 — — — — —, legal proceedings against,  
 328

- New England, lumber, markets, 395  
 — —, —, production, 275  
 — —, sawmills in, xvii
- New Hampshire cableway system used  
 in, 13  
 — —, lumber production in, 506  
 — —, wood-using industries of, 447
- New Jersey, lumber production in, 506  
 — —, wood-using industries in, 447
- New Mexico, lumber production in, 506
- New York, lumber production in, 506  
 — —, wood-using industries of, 447
- New York Lumber Trade Association,  
 319
- "Niagaras," 296
- Nigger, friction, 50, 50\*  
 —, steam, 45\*, 52
- North America, exports to, 1913-1920,  
 402  
 — —, imports from 428  
 — —, markets, 418
- North Carolina, lumber production in,  
 506  
 — —, wood-using industries of, 447
- North Carolina Dressed Lumber Co.,  
 307, 315
- North Carolina Pine Association, 307
- North Carolina Pine Lumber Co., 307
- North Carolina pine region, markets, 396  
 — — — —, sawmills, xvii
- Northeast, labor, 171  
 —, sawmills, 4
- Northeastern Lumbermen's Association,  
 310, 315
- Northeastern states, sawmills in, xvii
- Northern Hemlock and Hardwood Man-  
 ufacturers' Association, 311
- Northern Pine Manufacturers' Associa-  
 tion, 309  
 — — — —, grading rules of, 352
- Northwest, labor, 171, 172, 183  
 —, log lift, use in, 34  
 —, sawmills in, xvii  
 —, stocks at mills, 275  
 —, surface lumber carriers, use of, 144
- Northwestern Hemlock Manufacturers'  
 Association, 311  
 — — — —, grading rules of, 356
- Northwestern Lumbermen's Associa-  
 tion, 319, 322  
 — — — —, legal proceedings against, 327,  
 336
- Northwestern Lumber Manufacturers'  
 Association, 306, 313
- Oak, exports to Australia, 425  
 —, — — Belgium, 409  
 —, — — Chile, 422  
 —, — — France, 410  
 —, — — Germany, 411  
 —, — — Holland, 413  
 —, — — Italy, 413  
 —, — — Mexico, 419  
 —, — — Peru, 423  
 —, — — Portugal, 414  
 —, — — United Kingdom, 416  
 —, grades produced from, red, 489  
 —, — — —, southern, 490  
 —, — — —, white, 488  
 —, Japanese, imports of, 429  
 — logs, exports of, 403  
 — —, — —, Argentina, 420  
 — —, — —, Holland, 413  
 — lumber production, 508  
 — mill scale studies, 274
- Occupations, sawmill, 181
- Oceania, imports from, 428  
 —, lumber markets in, 425
- Odd-lengths, lumber, 270, 284  
 — —, —, Pacific Coast, 271
- Offset, sawmill carriage, 61, 62\*
- Ohio, lumber production in, 506  
 —, wood-using industries of, 446
- Oklahoma, lumber production in, 506
- Ontario, wood-using industries of, 447
- Open Competition Plan, 338
- Operators, lumber, sales methods, 382
- Oregon, lumber production in, 506  
 —, wood-using industries of, 447
- Oregon and Washington Lumber Man-  
 ufacturers' Association, 309
- Overhead cableway, log assorting and  
 storage, 28
- Overrun, sawmills, Minneapolis, Minn.,  
 77
- Pacific Coast, equipment sawmill, used  
 on, xvi, 60, 61\*, 68, 81, 83, 100,  
 102, 138, 145  
 — —, odd-lengths, lumber, 271
- Pacific Coast Lumber Manufacturers'  
 Association, 309, 355
- Pacific Coast Sugar and White Pine  
 Manufacturers' Association, 311

- Pacific Lumber Inspection Bureau, grading rules of, 355
- Pacific Northwest, lumber markets for, 399
- Pacific States, sawmills in, xvii
- Patterns, lumber, 271
- Payne-Aldrich Tariff Act, 433, 437\*
- Pennsylvania, lumber production in, 506  
—, wood-using industries of, 447
- Persimmon logs, export of, 413
- Peru, lumber market in, 423
- Piece work, sawmills, 174
- Pile, lumber, foundations, 208, 209\*  
—, —, roofs, 213
- Piling, sawmill foundations, 22
- Piling lumber, careless, 223\*  
—, —, methods of, 209
- Pine, eastern white, exports of, 401, 411, 413, 415, 420, 421, 422, 423, 425  
—, —, imports of, 428  
—, —, —, ports of entry, 429  
—, —, lumber production of, 508  
—, —, manufacturers' associations, 308  
—, —, —, Mississippi Valley Lumbermen's Association, 308  
—, —, —, Northern Pine Manufacturers' Association, 309  
—, —, —, Wisconsin Valley Lumbermen's Association, 309  
—, —, —, rules for grading, 352  
—, —, —, —, Mississippi Valley Lumbermen's Association, 352  
—, —, —, —, Northern Pine Manufacturers' Association, 352  
—, —, —, —, Tonawandas, 353  
—, —, —, tooth patterns for saws, band, 123  
—, —, —, —, circular, 117  
—, —, —, yield, saws, band, 282  
—, —, —, —, circular, 282  
—, Idaho, exports of, 415, 423  
—, —, grading rules for, 353  
—, —, sawing instructions for, 201, 203\*  
—, lodgepole, grading rules for, 354  
—, —, lumber production of, 508
- Pine, longleaf, products of average tree, 280  
—, —, weight, loss in dressing, 284  
—, North Carolina, manufacturers' associations, Carolina Dressed Lumber Association, 307  
—, —, —, Carolina Dressed Lumber Company, 307  
—, —, —, North Carolina Dressed Lumber Company, 307  
—, —, —, North Carolina Pine Association, 307  
—, —, —, South Carolina Lumber Association, 307  
—, —, —, Southern Dressed Lumber Association, 307  
—, Norway, grading rules for, 354  
—, —, tooth patterns, saw, 123  
—, mills, stocks of southern yellow, 275  
—, pitch, see southern yellow pine  
—, southern yellow, boards, width, 269  
—, —, depreciation during seasoning, 247  
—, —, exports of, 401, 409, 410, 411, 413, 414, 415, 416, 419, 420, 421, 423, 425  
—, —, flooring, dimensions of, 268  
—, —, grades, classification of sales by, 277  
—, —, —, distribution of, 276  
—, —, —, produced, 484  
—, —, grading rules for, 350  
—, —, lumber production, 508  
—, —, manufacturers' associations, 306  
—, —, —, Georgia-Florida Saw Mill Association, Inc., 307  
—, —, —, Georgia Interstate Saw Mill Association, 307  
—, —, —, Georgia Sawmill Association, 307  
—, —, —, Southern Lumber Manufacturers' Association, 306  
—, —, —, Southern Pine Association, 306  
—, —, —, Yellow Pine Manufacturers' Association, 306

- Pine, southern yellow, manufacture of timbers from, 266  
 —, —, slab-wood, use of, for pulp, 289  
 —, —, tooth patterns, saw, band, 123  
 —, —, —, —, circular, 117  
 —, sugar, depreciation of during seasoning, 245  
 —, —, exports, 414, 415, 422, 423  
 —, —, grades produced from, 273\*, 485  
 —, —, grading rules for, 354  
 —, —, lumber production, 508  
 —, —, manufacturers' associations, California White and Sugar Pine Manufacturers' Association, 312  
 —, —, —, Pacific Coast Sugar and White Pine Manufacturers' Association, 311  
 —, western yellow, depreciation of, during seasoning, 247  
 —, —, grades produced from, 484, 485  
 —, —, grading rules for, 353  
 —, —, lumber production, 508  
 —, western white, grading rules for, 353  
 Pipe, connections, wood-working, 259  
 Plain sawing, 192, 194\*  
 Planer-and-matcher, 252  
 Planing mill, 249  
 — —, odd lengths manufactured in, 270  
 Planks, exports, 1913-1920, 402, 403  
 —, imports, 1913-1920, 427, 428  
 Plant, re-manufacturing, building, 249  
 —, —, equipment, 251  
 Pole-stacking, lumber, 214  
 Pond, cleaning, 19  
 —, crew, 21  
 Poplar, yellow, exports of, 403, 411, 413, 416, 423, 425  
 —, —, lumber production of, 508  
 Portable sawmill plant, 4, 26\*  
 — — —, log storage for, 24  
 Portugal, lumber market in, 414  
 Power, planing mill, 263  
 —, sawmill, 157  
 Prairie Provinces, Canada, wood-using industries of, 447  
 Press rolls, edger, 102  
 Price control, association, 313  
 Prices, lumber, bibliography, 443  
 Products, lumber industry, 266  
 —, —, character, 266  
 Products, lumber industry, grades produced, 272  
 —, —, lumber patterns, 271  
 —, —, sizes, 267  
 —, —, stocks, 275  
 —, sawmill, routing of, pond to car, xviii\*  
 Production, lumber, by decades, xvi\*  
 —, —, —, decrease in, 392  
 —, —, —, regions, 392  
 —, —, —, species, 392, 508  
 —, —, —, states, 1879-1920, 506  
 —, —, —, states having a surplus, *Frontispiece*  
 Profile attachment, 253, 265  
 Progressive dry kilns, 228  
 Pulp, mill refuse used for, 289  
 Pumps, automatic boiler feed, 239  
 —, fire, 297  
 Quality, lumber, influence of log diameters and grades on, 272, 273\*  
 Quarter-sawing, 195, 195\*, 196\*, 198\*  
 —, eight-point method, 195, 195\*, 197  
 —, gum, red, 198\*  
 —, log dogs for, 59\*, 60\*  
 —, six-point method, 196, 196\*  
 Quebec, wood-using industries of, 447  
 Rack-and-pinion, 69, 69\*  
 Rafting lumber, 376  
 Rails, sawmill carriage, 55, 55\*  
 Rain, effect upon car weights of lumber, 367  
 Rates, freight, 367  
 Receder, set-works and, portable mill, 66, 66\*  
 Receding mechanism, friction, 65, 65\*  
 Reciprocity with Canada, 435  
 Redwood, exports, 403, 411, 415, 422, 423, 424, 425  
 —, grading rules for, 358  
 —, lumber production of, 508  
 —, manufacturers' associations, California Redwood Association, 312  
 —, markets for, 400  
 —, tooth patterns, saw, circular, 117\*  
 Redwood Company of California, 315  
 Re-edgers, 255  
 Refuse, burning of, 289  
 —, burners, 109  
 —, —, air-cooled, 111, 112\*

- Refuse, burners, capacity, 111, 112  
 —, —, enclosed, 110  
 —, —, grate surface, 110  
 —, —, open-pit, 109  
 —, —, relative fire hazard, 113, 515  
 —, disposal, burning, 289  
 —, —, fuel, 285  
 —, —, lath manufacture, 286  
 —, —, pulp stock, 289  
 —, —, shingles, 288  
 —, —, shorts and box stock, 288  
 —, equipment for handling, 257  
 —, fuel value, 286  
 —, fuelwood, use as, 286  
 —, grinders, 108, 108\*  
 —, hogged, air-velocity required to  
   move, 261  
 —, mill, disposal of, 279  
 —, —, volume of, 281  
 Re-manufacture, lumber, 248  
 —, —, equipment, 249, 263  
 Resaw, band, horizontal, 95, 95\*  
 —, —, vertical, 92, 92\*, 256\*  
 —, —, —, return roll system for, 93, 94\*  
 Resawing mills, 89  
 —, —, band, horizontal, 95, 95\*  
 —, —, —, vertical, 92, 92\*  
 —, —, circular gang, 96, 96\*  
 —, —, sash-gang, 89, 90\*  
 Retail associations, 318  
 Retail Lumber Dealers' Association of  
   Mississippi and  
   Louisiana, 322  
 —————, legal proceedings  
   against, 329  
 Retail Lumber Secretaries' Association,  
   321  
 Retail, methods of sale, 384  
 —, — — —, department stores, 387  
 —, — — —, farmers' stock companies,  
   386  
 —, — — —, mail-order houses, 386  
 —, — — —, retail yards, 385  
 —, yards, 385  
 Rhode Island, lumber production in, 506  
 Rip saw, 255  
 Rock saw, 97, 97\*  
 Rocky Mountain region, sawmills in,  
   xvii, 4  
 Roofs, lumber pile, methods of holding  
   down, 214, 214\*  
 Roller, feed, Coleman, 101, 101\*  
 Roller, live, 130, 131\*, 162  
 —, lumber-handling, 152  
 —, screw, 131, 131\*  
 —, skid, 132  
 Rollway, 12  
 Rollway and buggy, 27, 27\*  
 Rollway and canal, 28  
 Rule making, basis of, 346  
 Rules, grading and inspection, enforce-  
   ment of, 360  
 —, — — —, private and association, 349  
 —, — — —, state, 348  
 Runways, lumber yard, 205  
  
 Sales, exchange, 382  
 —, methods of, 380  
 —, — —, lumber advertising, 387  
 —, — —, retail, 384  
 —, — —, wholesale, 380  
 —, organizations, cypress, 308  
 —, southern yellow pine, classification  
   of, 277  
 Salt, use of, seasoning lumber, 217  
 Santa Clara Valley Mill and Lumber  
   Company, legal proceedings against,  
   327  
 Sap stain, prevention of, 219  
 Sash-gang mill, 89, 90\*, 162  
 Sawdust, air-velocity required to move,  
   261  
 —, fuel, use as, 285  
 —, volume, 281  
 Saws, band, feed speed, 127  
 —, —, filing-room equipment for, 127  
 —, —, fitting, 125  
 —, —, gauge, 122, 124  
 —, —, head, 122, 162  
 —, —, hook, 122, 123\*, 124  
 —, —, life of, 127  
 —, —, resaws, 127  
 —, —, self-contained mill, 89  
 —, —, size, 122, 510  
 —, —, speed, 126  
 —, —, swage, 122  
 —, —, tension, 126  
 —, —, tooth patterns, 122, 123\*, 124  
 —, —, wheel crown for, 125  
 —, —, yield of logs when cut by, 282  
 —, bibliography, 444  
 —, circular, gang, 96  
 —, —, head, 115, 162  
 —, —, —, fitting, 118

- Saws, circular, head, gauge, 115  
 —, —, —, hook, 116, 116\*  
 —, —, —, inserted-tooth, 119, 119\*  
 —, —, —, invention of, 115  
 —, —, —, life, 117  
 —, —, —, rim speed, 116, 513  
 —, —, —, size, 115  
 —, —, —, teeth, 116, 117, 117\*, 513  
 —, —, —, tension, 118  
 —, —, —, yield of logs when cut by, 282  
 —, cut-off, 36, 40\*, 121, 121\*, 162, 256, 257\*, 265  
 —, —, band, 41  
 —, —, deck, 39  
 —, —, drag, 36, 38\*  
 —, —, endless chain, 41  
 —, —, walking-beam, 39, 39\*  
 —, edger, 98, 120  
 —, filing-room equipment, 121, 127, 129  
 —, fitting, problems of, 118, 125, 128  
 —, gauge, 114, 115, 120, 121, 122, 126, 127, 128  
 —, gauge equivalents, 512  
 —, guide, edger, 100, 100\*  
 —, jump, 162  
 —, mulay, xv, 3  
 —, plate for, inserted-tooth, 119, 119\*  
 —, resaw, 127  
 —, rim speed of, band, 84  
 —, — — —, circular, 79  
 —, rip, 255  
 —, sash-gang, xv, 90, 90\*, 128  
 —, slasher, 108, 120  
 —, swing, 257, 257\*  
 —, teeth, band, 122, 123\*  
 —, —, circular, 115, 117\*  
 —, —, cut-off, 121, 121\*  
 —, —, deck cut-off, 120  
 —, —, edger, 119  
 —, —, head, 115  
 —, —, sash-gang, 128, 129\*  
 —, —, slasher, 120  
 —, —, trimmer, 120  
 Sawing, alive, 190  
 —, division of time in, 198  
 —, hardwoods, 194, 194\*  
 —, instructions for, 201  
 —, plain, 192  
 —, problems of, 189  
 —, quarter-, 195, 195\*, 196\*, 198\*  
 —, sawyer's signals, 199, 199\*  
 —, "through and through," 190  
 Sawing, western white pine, 202, 203\*  
 Sawmills, band, 77, 81  
 —, —, double-cutting, 85, 87\*  
 —, —, pony, 85  
 —, —, single-cutting, 83, 83\*  
 —, —, twin, 87  
 —, bibliography, 443  
 —, buildings, dimensions, 22  
 —, —, elevations of, 23\*, 25\*  
 —, —, fire hazards of, 22  
 —, —, foundations, 24  
 —, —, plans for, 23, 25  
 —, —, size, 24  
 —, —, types, 22, 23  
 —, circular, 77  
 —, —, breaking-down, 81  
 —, —, double, 78, 79\*  
 —, —, single, 78, 78\*  
 —, —, twin, 80, 80\*  
 —, distribution, xvii  
 —, equipment, 22  
 —, horse-power, 160  
 —, number, xvii  
 —, plants, character of, xviii  
 —, plan, ground, 10\*  
 —, pony-band, 77, 85  
 —, portable, 4, 26\*, 157  
 —, —, fuel for, 285  
 —, power plants, 157, 159  
 —, production, by classes, xvii  
 —, products, routing of, pond to car, xviii\*  
 —, sawing floor, 43\*  
 Savannah Rules of 1883, 351  
 Sawyers' signals, 199, 199\*  
 Scantlings, exports, 1913-1920, 402, 403  
 Schedule D, Underwood-Simmons Tariff Act, 517  
 Seasoned lumber, measuring moisture conditions in, 505  
 Seasoning lumber, air, 205  
 — —, bibliography, 444  
 — —, depreciation of lumber in, 244  
 — —, dry kilns, 224  
 — —, effect of, on weight, 247  
 — —, hardwoods, in sheds, 215, 215\*  
 Semi-portable sawmill, 5, 24  
 Separator, dust, or cyclone, 262, 262\*  
 Set-works, carriage, 62, 63\*, 64\*, 66\*, 67\*  
 —, —, dial, 65, 65\*  
 —, —, electrical power for, 68  
 —, —, endless rope feed for, 68

- Set-works, carriage, hand-operated, 63  
 —, —, steam-driven, 66, 67\*
- Shaft- and belt-drive, planing mill, 263  
 — — — —, sawmill, 160
- Shafting, sawmill, 160
- Shavings, air-velocity required to move, 261  
 —, disposal, 257  
 —, volume, 258  
 —, weight, 284
- Shed, storage, lumber, 216
- Sheds, seasoning hardwoods in, 215, 215\*
- Shingles, imports, 429, 437\*  
 —, manufacture of, 267  
 —, production of, 506  
 —, source, 288
- Shorts, manufacture of, from mill refuse, 288  
 —, size of, 288
- Shrinkage of wood, average, 503, 504
- Single log chain, 33
- Single yards, retail, 385
- Size, products, lumber, 497  
 —, —, —, cedar, 500  
 —, —, —, cypress, 501  
 —, —, —, fir, Douglas, 500  
 —, —, —, hardwood, 502  
 —, —, —, hemlock, western, 500  
 —, —, —, pine, eastern white, 499  
 —, —, —, —, North Carolina, 498  
 —, —, —, —, southern yellow, 497  
 —, —, —, spruce, 500, 502  
 —, —, —, sawed, 267
- Sizer, timber, 252, 253\*, 265
- Skid roller, 133
- Skids, log, 26
- Sky-line, Clark-Nickerson, lumber, 153, 153\*
- Slabs, use for, fuel, 285  
 —, — —, lath manufacture, 286  
 —, — —, — —, yield, 287  
 —, volume of, in log conversion, 282
- Slasher, 107, 107\*, 162
- Smoke kiln, 229
- Snow, effect upon car weights, 367
- Social welfare, housing and, 172
- Sodium bi-carbonate, prevention of sap stain with, 220
- Softwoods, market, lumber, 395-400  
 —, method of stacking, lumber yards, 209
- Softwoods, uses of, 346
- Sorter, edge, 137, 138\*
- South, sawmill plants, floating, 4  
 —, — —, labor, 171, 183
- South America, exports to, 1913-1920, 402  
 — —, imports from 428  
 — —, markets, lumber, 420  
 — —, —, —, Argentina, 420  
 — —, —, —, Brazil, 421  
 — —, —, —, Chile, 422  
 — —, —, —, Peru, 423
- South Carolina, lumber production in, 506  
 — —, wood-using industries of, 448
- South Carolina Lumber Association, 307
- South Dakota, lumber production in, 506
- Southern Cypress Lumber Association, 308
- Southern Cypress Lumber and Shingle Association, 308  
 — — — — — — — —, grading rules of, 357
- Southern Cypress Lumber Selling Co., Ltd., 308
- Southern Cypress Manufacturers' Association, 308, 388, 389  
 — — — — — — — —, grading rules of, 357
- Southern Dressed Lumber Association, 307
- Southern Land and Timber Association, 350
- Southern Lumber Manufacturers' Association, 306, 314, 315
- Southern Pine Association, 306  
 — — — —, grading rules, 350  
 — — — —, legal proceedings against, 341  
 — — — —, standard sizes of products, 268, 497
- Southern Poplar Lumber Co., 315
- Southern states, number of sawmills in, xvii
- Southern yellow pine region, markets, 397  
 — — — — — — — —, time required to air-season lumber in, 218
- Southwestern Washington Lumber Manufacturers' Association, 309
- Spain, lumber market in, 414
- Sparks, as a cause of sawmill fires, 292
- Sprinkler system, fire protection, 298
- Spruce, eastern, exports of, 401, 411, 416, 420, 421, 424, 425

- Spruce, eastern, grading rules for, 356  
 —, —, imports of, 428  
 —, —, length of sawed products, 269  
 —, —, yield of laths, per cord, 287  
 —, Engelmann, grading rules for, 357  
 —, inspection rules, 311  
 —, lumber production of, 508  
 —, manufacturers' associations, 310  
 —, —, Adirondack Lumber Manufacturers' and Shippers' Association, 310  
 —, —, Empire State Forest Products Association, 310  
 —, —, Northeastern Lumbermen's Association, 310  
 —, —, Spruce Manufacturers' Association, 310  
 —, Sitka, exports, 423  
 —, —, grading rules, 356  
 —, — tooth patterns, band saw, 123  
 — slab-wood, use for pulp, 289  
 Spruce Manufacturers' Association, 310  
 — — —, grading rules of, 356  
 Stacker, lumber, automatic, for dry kiln trucks, 241, 241\*  
 —, —, Hilke, 212, 213\*  
 —, —, portable, log unloader and, 15, 15\*  
 State rules, grading and inspecting lumber, 348  
 Statistics, association, collection and issuance of, 315  
 —, —, bibliography, 445  
 Steam feed, sawmill carriage, 73, 74\*  
 Steam-producing equipment, sawmills, 163  
 — — —, boilers, 163  
 — — —, —, settings for, 163, 164\*  
 — — —, forced draft, 165, 166\*  
 — — —, grates, 165, 165\*  
 — — —, horse-power, 163  
 — — —, mechanical stoking, 164\*, 166  
 Stock mills, production of lumber at, 275  
 Stocks at mills, "balanced," 276  
 — — —, "unbalanced," 276  
 — — —, volume on hand, 275  
 Strips, edging, volume of, log conversion, 283  
 Suction, dust-collecting system, 260  
 Sugar pine, depreciation during seasoning, 245  
 — — —, grades produced, 273\*, 485  
 — — —, lumber production, 508  
 Superheated-steam kilns, 234  
 Swedish Lumber Exporters' Association, 407  
 Sycamore, import duty on, 428  
 —, lumber, production of, 508  
 Syndicate of Lumber Importers of Belgium, 409  
 Table assorting, 136  
 —, automatic feed, 254, 255\*  
 Tamarack, grading rules for, 357  
 Tank, metal, for dipping lumber, 220, 221\*  
 —, water, capacity, 297  
 Taper set, sawmill carriage, 57\*, 58  
 Tariff Acts, Dingley, 428, 432  
 — — —, early, 429  
 — — —, McKinley, 431  
 — — —, Morrill, 431  
 — — —, Payne-Aldrich, 433  
 — — —, Reciprocity with Canada, 435  
 — — —, Wilson, 432]  
 — — —, Underwood-Simmons, 436  
 Teche and Gulf Coast Cypress and Shingle Association, 307  
 Teeth, saw, band, 122, 123\*  
 —, —, circular, 115, 117\*, 119\*, 513  
 —, —, cut-off, 121, 121\*  
 —, —, sash-gang, 128, 129\*  
 —, —, spring-set, 114, 114\*  
 —, —, swaged, 114, 114\*  
 Temperature, dry kiln seasoning, 227, 231, 234  
 —, instruments for recording, 239  
 Tennessee, lumber production in, 506  
 —, wood-using industries of, 446  
 Texas, lumber production in, 506  
 —, wood-using industries of, 447  
 The Hardwood Manufacturers' Institute, 344  
 Timbers, hewed and sawed, exports of, 402  
 —, — — —, source, 266  
 Timber sizer, 252, 253\*  
 Toledo, Ohio, retailers, legal proceedings against, 333  
 Tonawanda rules, grading and inspecting eastern white pine, 353  
 Tonnage, rail, 363  
 Tooth patterns, saw, 114, 117, 119, 121, 123, 129  
 Track, sawmill carriage, 55, 55\*



- Track, system for small rail cars, 155\*
- Track-cleaning device, sawmill carriage, 56, 56\*
- Traction engine, transportation of lumber with, 374
- Tractor, lumber handling, 142, 143\*
- Trade-marking lumber, 389
- Trailer, sawmill carriage, 54, 55\*
- Transfers, lumber, 132, 132\*
- Transit shipments, rail, 372
- Transportation, lumber, bibliography, 443
- , —, motor trucks for, 374
- , —, rail, 363
- , —, —, car, capacity, 365
- , —, —, —, stakes, 364
- , —, —, —, weighing service, 366
- , —, —, classification, 369
- , —, —, freight rates, 367
- , —, —, milling-in-transit, 371
- , —, —, tonnage, 363
- , —, —, transit shipments, 372
- , —, traction engine, 374
- , —, sawmill plants, cableway, 152
- , —, —, —, cranes, 148
- , —, —, —, lumber sky line, 153
- , —, —, —, monorail, 145
- , —, —, —, rollers and chains, 152
- , —, —, —, surface carriers, 144
- , —, —, —, wheeled vehicles, 140
- , —, water, barges, 376
- , —, —, rafts, 376
- , —, —, vessels, 375
- Traps, steam, dry kilns, 237, 237\*, 238\*
- Trestles, lumber yard runway, 206, 207\*
- Tree, merchantable volume of, 279
- , products of a longleaf pine, 280
- Trimmer, 102, 162
- , overhead, 104, 105\*
- , table for, 104\*
- , three-saw, 103, 103\*
- , two-saw, 103
- , under-cut, 106, 106\*
- Trimming, 200
- , odd-lengths, 284
- , volume of, log conversion, 284
- Trips, lumber, 132, 133\*
- Trucks, dry kiln, 235, 236\*
- , —, —, loading, 240, 241\*
- , —, —, unloading, 242
- , four-wheeled, 142
- , sawmill carriage, 53\*, 55
- Tupelo, exports, 414, 415
- , lumber production of, 508
- Turner, log, friction, 50, 50\*
- , —, overhead, 48, 48\*
- , —, portable sawmill, 51, 51\*
- , —, Simonson, 49, 49\*
- , —, steam nigger, 45\*, 52
- Twin-band vertical resaw, 93
- Underwood-Simmons Tariff Act, 436, 437\*
- — — —, Schedule D, 517
- Union Lumber Company, Ltd., of Texas, 315
- Unions, labor, Brotherhood of Timber Workers, 183
- , —, International Union of Timberworkers, 184
- , —, International Workers of the World, 184
- , —, Knights of Labor, 183
- , —, Loyal Legion of Loggers and Lumbermen, 183
- United Association of Lumbermen, 320
- United Kingdom, lumber markets in, 415
- Universal Constitution, retail associations, 320
- Utah, lumber production of, 506
- Value, lumber, stocks on hand, 301
- Vehicles, wheeled, 140
- , —, lumber buggies, 140, 141, 141\*
- , —, tractors, 142, 143\*
- , —, trucks, 142
- , —, wagons, 142, 142\*
- Vermont, lumber production in, 506
- , wood-using industries of, 447
- Vessels, transportation of lumber in, 375
- Virginia, lumber production in, 506
- , wood-using industries of, 448
- Volume, merchantable, of a tree, 279
- Wages, lumber industry, 173
- Wagon, lumber, four-wheeled, 142, 142\*
- Walnut, black, exports, 403, 411, 413, 415, 416, 420, 423
- , —, lumber production of, 508
- Waste, lumber manufacture, bibliography, 446
- , —, —, disposal of, 279

- Washington, lumber production in, 506  
 —, wood-using industries of, 447  
 Watchmen, sawmill plants, 293  
 Water barrels and buckets, fire control, 294  
 — power, sawmill, 6  
 — storage, logs, 16  
 — transportation, lumber, 375  
 Webb-Pomerene Bill, 408  
 Weights, lumber, 226, 249, 493, 495  
 —, —, effect of seasoning on, 247  
 —, —, hardwood, 496  
 —, —, loss of, during re-manufacture, 249, 258  
 —, wood, average, 493  
 West Coast Lumbermen's Association, 309  
 — — — —, grading rules, 355  
 — — — —, legal proceedings against, 342  
 West Coast manufacturers' associations, Lumber Manufacturers' Association of the Northwest, 309  
 — — — —, Oregon and Washington Lumber Manufacturers' Association, 309  
 — — — —, Pacific Coast Lumber Manufacturers' Association, 309  
 — — — —, Southwestern Washington Lumber Manufacturers' Association, 309  
 — — — —, West Coast Lumbermen's Association, 309  
 — — — —, West Coast Lumber Manufacturers' Association, 309  
 West Indian markets, lumber, 423  
 West Indies, exports to, 402  
 West Virginia, lumber production in, 506  
 — —, markets, 396  
 — —, sawmills in, xvii  
 — —, wood-using industries of, 447  
 Western Pine Manufacturers' Association, 311  
 — — — —, grading rules of, 353, 357  
 — — — —, legal proceedings against, 343  
 Western Pine Shippers' Association, 311  
 — — — —, grading rules of, 353  
 Whip-sawing, 3  
 Whitewood, export duty on, 428  
 Wholesale associations, American Wholesale Lumber Association, 325  
 — —, Cleveland Board of Lumber Dealers, 323  
 — —, Lumber Exchange of Baltimore, 323  
 — —, National Bureau of Wholesale Lumber Distributors, 325  
 — —, National Hardwood Lumber Association, 309, 317  
 — —, National Wholesale Lumber Dealers' Association, 323  
 — —, Pacific Coast Shippers' Association, 325  
 —, cargo centers, 380  
 —, markets, central, 381  
 —, methods, commission, 383  
 —, —, dealers, 383  
 —, —, early, 380  
 —, —, operators, 381  
 Width, sawed products, 269  
 Wilson Tariff Act, 432, 437\*  
 Wisconsin, lumber production in, 506  
 —, wood-using industries of, 448  
 Wisconsin Hardwood Lumbermen's Association, 311  
 Wisconsin Valley Lumbermen's Association, 309  
 Wood, cabinet, ports of entry, 429  
 —, —, volume of imports, 428  
 —, shrinkage of, average, 503, 504  
 —, weights of, 493  
 Wood-using industries, bibliography, 446  
 Wood-working machinery, bibliography, 448  
 Workmen's Compensation Acts, 186  
 Wyoming, lumber production in, 506  
 Yard, lumber, location, 205  
 —, —, piles, foundations for, 208  
 —, —, —, roofs for, 213, 214\*  
 —, —, piling methods, 209  
 —, —, pole-stacking, 214  
 —, —, runways, 205  
 —, —, sanitation, 222  
 Yellow Pine Manufacturers' Association, 306  
 — — — —, legal proceedings against, 331

- |   |  |   |
|---|--|---|
| Yellow Pine Manufacturers' Association,<br>length standards of, 270 |  | Yellow poplar, manufacture, box shooks<br>from, 267               |
| Yellow poplar, exports, 411, 413, 414,<br>416, 423, 425             |  | — —, —, laths from, 267, 287<br>— —, slab-wood, use for pulp, 289 |













DEC 1 1993

**UNIVERSITY OF TORONTO  
LIBRARY**

Forestry

(772600)

**DO NOT  
REMOVE  
THE  
CARD  
FROM  
THIS  
POCKET**



