

This book belongs to,
James E. Hudgins
2106 Grandblanca
Napack, Va. U.S.A.

Atsuko IF Bernot, May 1985

~~400~~
400
amm

(lists at 350 in
1973 Used Books
Price Guide)

f

p

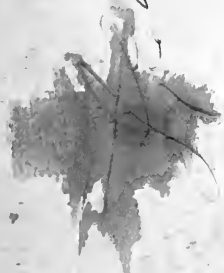



UNITED STATES SHIPPING BOARD FLAG

MANUAL
FOR THE GUIDANCE OF APPRENTICES
ON TRAINING SHIPS

BY

CAPT. EUGENE E. O'DONNELL

Formerly Supervising Inspector of Steam Vessels and
Supervisor of Sea Training



ISSUED BY
RECRUITING SERVICE
SEA TRAINING BUREAU

1918

PRESS OF
THE YACHTSMAN'S GUIDE
BOSTON, MASS.

Copyright 1918 by E. D. Wilson

PREFACE.

The rapidly growing demand for men to operate the ships of our Merchant Marine prompted the U. S. Shipping Board, early in 1918, to organize the Sea Training Bureau of the Recruiting Service with a view to supplying intensive training to young men desirous of qualifying as seamen.

As this work proceeded, it quickly became apparent that there was need of a comprehensive text book for use in the classes on the training ships, and "The Sea-Training Manual" was therefore compiled.

In the preparation of the Manual, minute and technical detail was intentionally avoided owing to the limited space of time devoted to the work on the training ships, for it is believed that after leaving the ship the apprentice will quickly adapt himself to the varying details and technicalities of the different types of vessels.

The limited amount of space in the Manual renders it impossible to treat the various subjects in detail and no attempt is made to supply information beyond what is absolutely essential. The apprentice after completing his course may readily procure text books treating directly upon the particular branch of the service in which he may be engaged.

The value of the Manual has been proved by the interest aroused among the apprentices and by their rapid advancement.

The compilation of "The Sea-Training Manual" has been made easy by the hearty co-operation of those who are in a position to render assistance in matters of this kind, and the author desires to express his thanks for valued assistance freely given.

E. E. O'D.

TABLE OF CONTENTS AND GENERAL INDEX.

	Page
PREFACE	
INTRODUCTION	
TRAINING SHIPS OF RECRUITING SERVICE	
STATUS OF MERCHANT SEAMEN	12
DISCIPLINE	13-14
TIDINESS	14
SEAMANSHIP	
Bell Time on Shipboard	15
To Mark a Lead Line	15
How to Call a Cast of the Lead	16
The Sounding Machine (Illustrated)	16-18
Knots and Miles	19
Steering Orders	19
Rules of the Road at Sea	20-21
Winds and Effect on Sound Signals	22
Wind Force (Beaufort's Scale)	22-23
Beaufort Notation (Disturbance of Sea Surface)	23
Boxing of Mariner's Compass	23
Watches as Compasses	23
The Mariner's Compass (Diagram)	24
Tables Showing Degrees and Fractions of Degrees	25
Seizings, Hitches, Bends, Splices, Etc. (Illustrated)	26-27
Knots, Bends and Splices (Illustrated)	28-38
Fancy Knots (Illustrated)	39-47
Wire Rigging	47
Working in Wire Rope (Illustrated)	48-53
Parts of a Block (Illustrated)	54
Blocks and Tackles (Illustrated)	55-57
Strength and Weight of Manila Rope	57
SAILING VESSELS	
The "Cat" Rig (Illustrated)	58
The "Sloop" Rig (Illustrated)	59
The "Cutter" Rig (Illustrated)	60
Topsail Schooner (Illustrated)	61
Brigantine (Illustrated)	61
Brig (Illustrated)	61
Schooner, 2 Mast (Illustrated)	62
Names of Spars, Sails, Etc., 2 Mast Schooner	63
Bark-Sails (Illustrated)	64
Bark-Masts and Spars (Illustrated)	65
Four Mast Bark-Sails (Illustrated)	66
Five Mast Bark-Sails (Illustrated)	67
Full Rig Ship-Masts and Spars (Illustrated)	68
Full Rig Ship-Standing Rigging (Illustrated)	69
Full Rig Ship-Running Rigging (Illustrated)	70
Full Rig Ship-Sails (Illustrated)	71
Full Rig Ship-Staysails (Illustrated)	72
Four Mast Ship-Spars and Sails (Illustrated)	73
Notes on Wooden Ship-Building	74-76
Launching	76-77
Names by which Parts of Wooden Ships are known	77-84
A. Sectional Diagrams—Wooden Ship Construction	78-81
B. Materials and Fastenings (Wooden Ships)	84-85
STEAM VESSELS	
Merchant Vessels (Illustrated)	86-89
The Difference Between Gross and Net Tonnage	90

INDEX—Continued

DESIGN AND CONSTRUCTION OF STEEL MERCHANT STEAMSHIPS

Emergency Fleet Standard Steel Steamship	92-95
A. Standard Steel Steamship (Longitudinal Section) ..	91
B. Standard Steel Steamship (Midship Sections)	93-94
Composite Steamship Construction	95
A. Composite Steamship (Midship Section)	96
STOWAGE OF CARGO	97-99
LOAD LINE MARKS, ETC.	100

STATION BILL

General Instructions for Fire Drill	101
Muster List (International Mercantile Marine)	102-105
General Instructions for Boat Drill	106
Miscellaneous Remarks on Duties at Fire and Boat Drill ..	106
Definition of Terms Used in Fire and Boat Drill	106-107
Boat Service (Rowboats)	107

DUTIES OF COAL PASSERS, FIREMEN, WATER-TENDERS AND OILERS

1. Coal Passers, Duties, Etc.	108
2. Firemen, Duties, Etc.	108-109
3. Oilers, Duties, Etc.	109-110
4. Water-Tenders, Duties, Etc.	110-111

MARINE BOILERS AND ACCESSORIES

Types of Boilers (Illustrated)	112-116
Safety Valves (Illustrated)	116-117
Water Gauge and Test Cocks (Illustrated)	117-118
Steam Gauge (Illustrated)	118-120
Stop Valves (Illustrated)	120-121
Check Valves (Illustrated)	122
Fusible Plugs	123

THE USE OF OIL FOR FUEL ON STEAM VESSELS124-132

BOILER ROOM AUXILIARIES

Feed Pumps, Etc.	133
Relief Valve (Illustrated)	133
Vertical Duplex Feed Pump (Illustrated)	134
A. Names of Parts	135
Feed Water Heater	135
Plunger Feed Pump (Illustrated)	136
Circulating Pump (Illustrated)	137
Condenser (Illustrated)	138-139
Air Pump	139
A. Diagrams of Air Pump	140
B. Lists of Parts	141
Evaporator (Illustrated)	142

MARINE ENGINES FOR MERCHANT SERVICE

Reciprocating Engines (Illustrated)	143-146
A. Names of Parts	145
Turbine Marine Engines (Illustrated)	146-163
Glands, Packing and Lubrication	147
"Parsons" High Pressure Turbine Engine (Cross Section) ..	148
A. Section Through Steam Strainer and Controls	149
Plan of Engine Room Showing Location of Turbines, Etc.	150
General Electric Marine Geared Turbine, Description	151
General Electric Marine Geared Turbine (Sectional Diagram) ..	152
List of Parts, General Electric Marine Geared Turbine ..	153-154
A. Diagram Showing Arrangement of Gears, Shafts and Bearings	155

INDEX—Continued.

B. Reduction Gears	156
C. Diagram Showing Steam Seals and Packing	157
Instructions for Care and Operation of General Electric Marine Geared Turbine	157-163
INTERNAL COMBUSTION MARINE ENGINES	
The Diesel Oil Engine	163-164
A. Diesel Engines (Illustrated)	164-167
CARE AND SUPERVISION	
Supervision of Bearings and Moving Parts (Machinery) ..	168-169
Hot Eccentric Sheaves and Straps	169
Heating of Guides	170
Hot Crosshead	170
Hot Piston Rod	170-171
Hot Main Bearings	171
Hot Crankpin	172
Hot Thrust Block	172
BOUYAGE—AIDS TO NAVIGATION	173-174
SIGNALS USED BY MARINERS	
Signals from Pilot House to Engine Room	175
Signals of Distress	175
International Code of Signals	176
International Code in Colors	177-179
United States Storm Warnings in Colors	180
United States Storm Warnings	181
Signals by Morse Code	182-185
Signaling by Light or Sound	185
Signaling by Semaphore, Etc.	186-187
Signaling by Shapes, Etc.	188-194
Signaling by Flag Waving, Wig-Wag, Etc.	194-197
HELP IN CASE OF ACCIDENTS	
Directions for First Aid, Drowning, Etc.	198-207
To Restore Persons Apparently Dead from Drowning ...	208-212
Life Saving by Gun, Rocket and Breeches Buoy	213
REQUIREMENTS FOR LICENSING OF DECK OFFICERS	
Licensing of Masters of Ocean Steam Vessels, Etc.	214-215
Licensing of Masters of Coastwise Steam Vessels	216
Licensing of Masters of Sail Vessels	217
Licensing of Chief Mate of Ocean Steam Vessels	217-218
Licensing of Second Mate of Ocean Steam Vessels	218-219
Licensing of Third Mate of Ocean Steam Vessels	219
Licensing of Chief Mate of Coastwise Steam Vessels	220
Licensing of Second Mate of Coastwise Steam Vessels ...	220-221
Licensing of Third Mate of Coastwise Steam Vessels	221-222
REQUIREMENTS FOR LICENSING OF ENGINEERS	
Licensing of Chief Engineer of Ocean Steam Vessels	222
Licensing of First Assistant Engineer of Ocean Steam Vessels	222-223
Licensing of Second Assistant Engineer of Ocean Steam Vessels	223-224
Licensing of Third Assistant Engineer of Ocean Steam Vessels	224
Qualifications and License Form for Engineers	224
NAUTICAL DICTIONARY	
Definition of Terms	225-256
Questions for Apprentices	257-261

INTRODUCTION

AMERICAN MERCHANT SEAMEN!

The Government of our Country asks our young men to give of their best and often their lives as well, and it has never yet been said that they have failed to measure up to their opportunities. When the history of these years shall be written, make sure that your record will be that of duty well and eagerly performed, as no other story has ever been told of American seamen.

With few exceptions, the thousands of apprentices which have taken the course of instruction, have made good, many of them having been promoted to higher positions in their respective departments after the first voyage.

The opportunity for rapid advancement is ever present to the earnest and willing worker, and what today is a duty, tomorrow becomes a pleasure, to the apprentice determined to succeed.

The vast fleet of vessels now being built to supply the needs of our Army engaged in the titanic struggle to preserve the freedom of humanity, ensures advancement to all who are determined to master the details of the profession and prove themselves capable and resourceful seamen.

The apprentice should always have in mind the dignity and importance of his work, and his conduct and willingness to learn while in training may well be considered as a barometer indicating his desire to fit himself to most effectively serve his Country.

Think not of the sacrifice you are making; count not the cost; but simply resolve with the other thousands of young men offering themselves for sea service that your Country calls and you respond, determined that the principles of Liberty and Justice shall survive.

SUPERVISOR OF SEA-TRAINING.

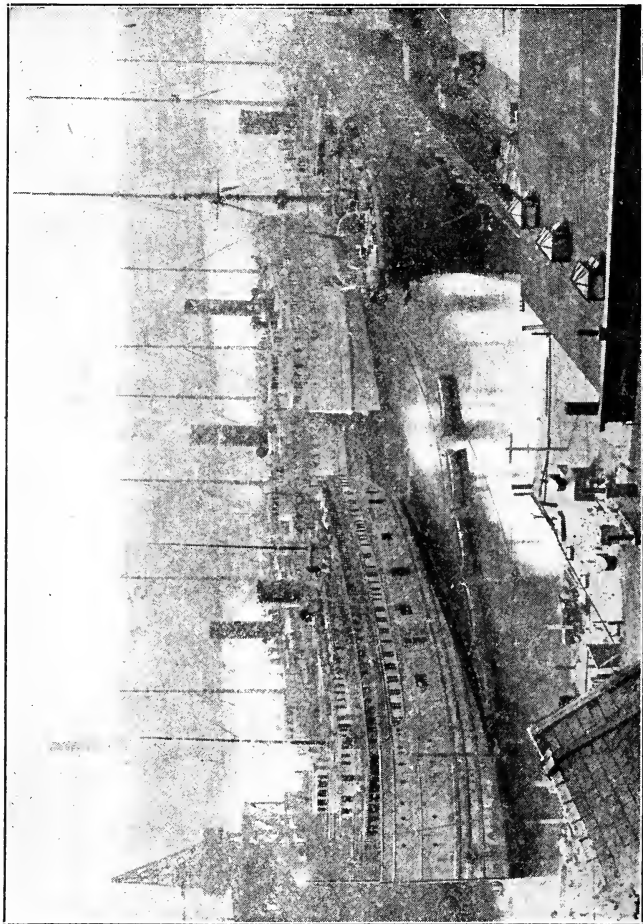

Headquarters of Recruiting Service at Boston, showing fleet of Training Ships.

Left to right — steamers Governor Dingley, Governor Cobb, Calvin Austin and U.S.S. Meade. In foreground, steamer Minnesota.

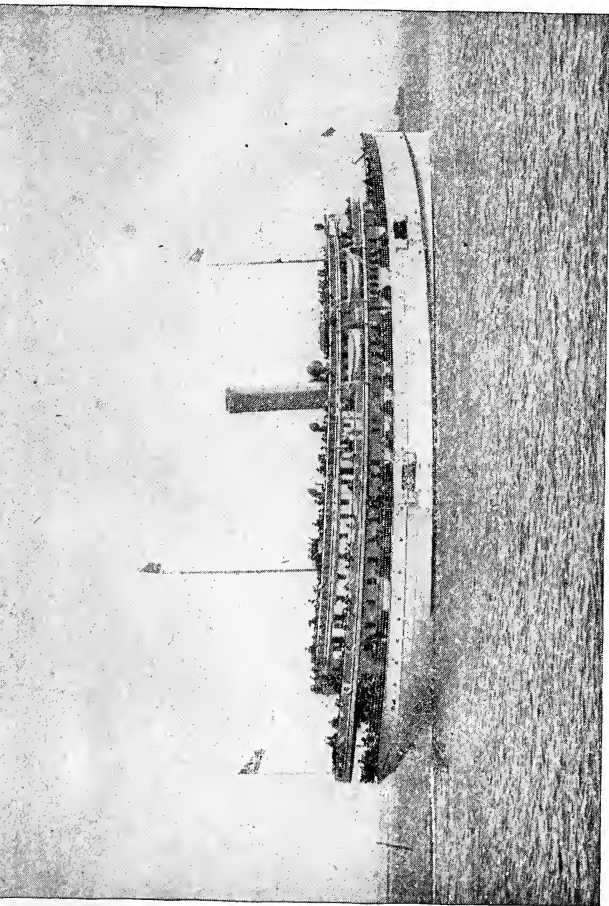

Steamship DOROTHY BRADFORD, Training Ship of the Recruiting Service.

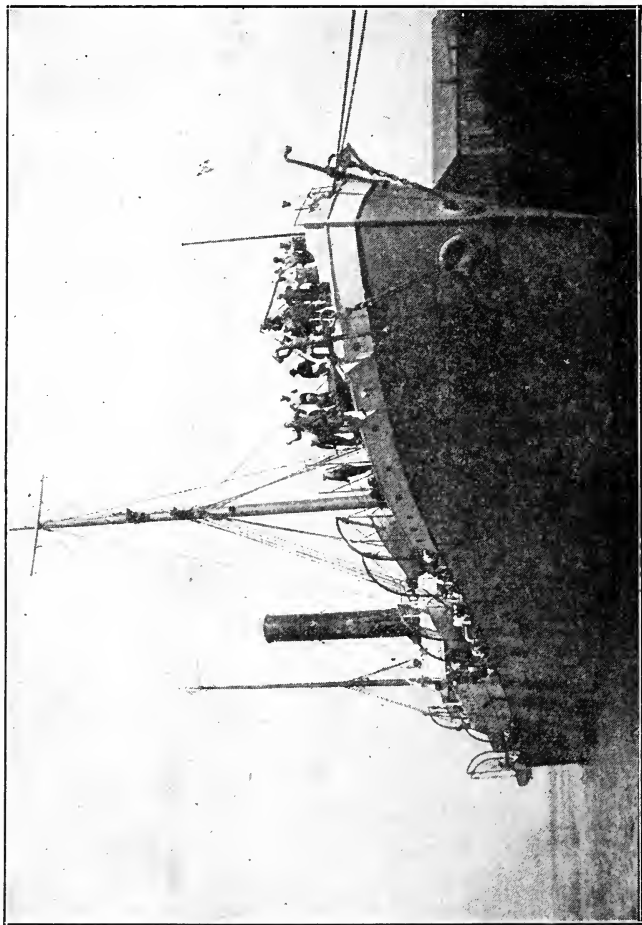

Steamship IRIS, Training Ship of the Recruiting Service.

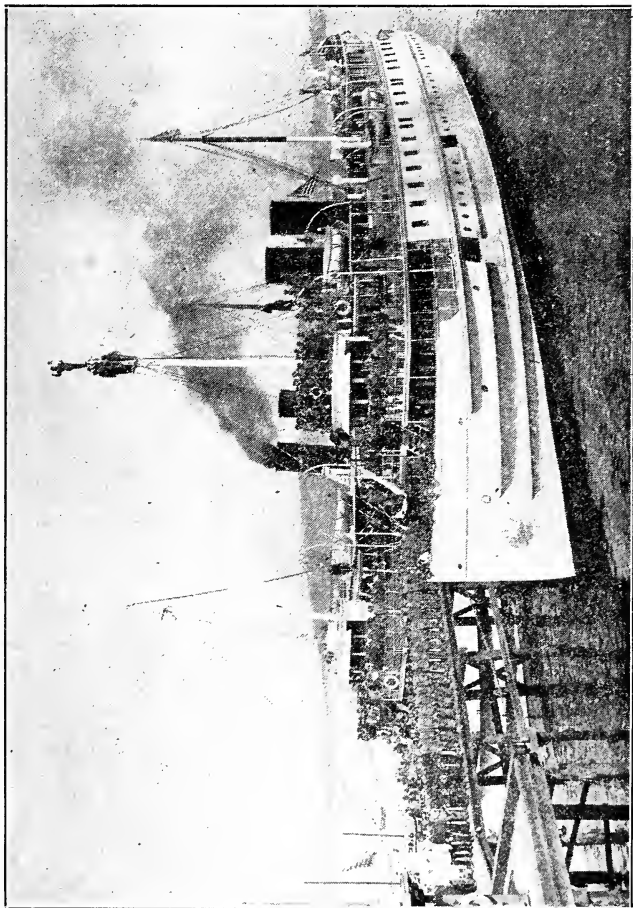

Steamships CHIPPEWA and IROQUOIS, Training Ships of the Recruiting Service.

STATUS OF MERCHANT SEAMEN

Every person having the command of any vessel belonging to any citizen of the United States shall be deemed to be the "master" thereof; and every person (apprentices excepted) who shall be employed or engaged to serve in any capacity on board the same shall be deemed and taken to be a "seaman;" and the term "vessel" shall be understood to comprehend every description of vessel navigating on any sea or channel, lake or river, to which the provisions of this Title may be applicable, and the term "owner" shall be taken and understood to comprehend all the several persons, if more than one, to whom the vessel shall belong.

*Pilots, mariners actually employed in the sea service of any citizen or merchant within the United States, and all persons who are exempted by the laws of the respective States or Territories shall be exempted from militia duty, without regard to age.

*Under the Selective Service Regulations, called the Draft Law, apprentices in training on the Training Ships of the United States Shipping Board and subject to draft are exempted from draft upon request of the Supervisor of the Training Ships. This exemption, however, applies only so long as the apprentice so exempted follows the vocation of a mariner, either in training or in actual sea service thereafter. In case an apprentice is no longer thus exempted, he then becomes subject to draft according to the classification given him under his Questionnaire.

DISCIPLINE

Obedience is the first principle of discipline. There is an orderly way to perform every task, it matters not how simple or how difficult it may be. Work on shipboard is carried on in a certain prescribed manner, each officer of the ship being in charge of various squads of men, while in performance of certain definite duties, the master in general charge over all, his jurisdiction resembling that of the Governor of a State over the heads of the various executive departments.

It is necessary, therefore, that an apprentice should diligently apply himself as soon as he is assigned to a training ship and learn his proper place on board; become conversant with his duties, paying particular attention to the daily instructions of the Chief Officer on discipline.

Respect for authority is necessary at all times,—this is true of any well organized body. When orders are given, they must be obeyed promptly and without argument or question. To properly carry out an order given by a superior officer, it must be done with due respect toward the person in authority.

Promptness and regard for authority are simple requirements which necessarily exist and form a part of the regular duty of an apprentice, just as much as the actual performance of the work assigned to him.

The successful apprentice, who will eventually become the successful Master or Chief Engineer, will not make the mistake of refusing to obey orders or of obeying them reluctantly.

An apprentice desiring to speak to an officer or an instructor shall, on approaching him, salute by facing the officer or instructor at attention raising his hand to cap; the hand should again be raised to the cap when he has finished.

In passing an officer on board ship or ashore the same salute shall be given. An officer of the Shipping Board, or of the Army or Navy shall be saluted in a similar manner, whether in uniform or civilian clothes.

If an apprentice desires to communicate with the Master of the Training Ship, he should obtain permission from the Chief Officer, who will appoint a time, should it be found that there is good and sufficient reason for the apprentice's request to consult the master.

The routine of work on shipboard from day to day will be determined by the Master and will be carried into effect by the Chief Officer and Chief Engineer through the various officers and instructors.

The following breaches of discipline and conduct will not be countenanced:

1. Disobedience.
2. Indecency.
3. Disorderly conduct.
4. Shirking work.
5. Untidiness.
6. Smoking out of hours.
7. Smoking in staterooms or in unauthorized parts of the vessel.
8. Throwing lighted cigars, cigarettes, or matches about ship or in dangerous places.
9. Using other than safety matches. (Safety matches will be provided by the ship's steward.)
10. Destroying clothing.

11. Borrowing or lending clothing.
12. Leaving station without permission.
13. Neglect of or inattention to duty.
14. Prevarication.
15. Profanity.
16. Skylarking at meals.
17. Destroying food.
18. Mutilating or destroying ship's property.
19. Being under the influence of liquor on board ship or ashore.
20. Insolence to an officer or instructor.
21. Leaving the ship without permission.
22. Attempting to bring liquor on board.
23. Overstaying liberty.
24. Desertion.

The master of the ship shall, in all cases, determine the punishment for any of the acts mentioned above. A hearing by the master will always be granted to an apprentice charged with an offence.

Healthy forms of amusement will be provided during leisure hours and off watches and an apprentice will find that there are many ways in which he may find entertainment while in training. No excuse for skylarking will, therefore, be accepted.

TIDINESS

The efficiency of an apprentice is not determined solely by the amount of work he can accomplish or his willingness to perform his duty promptly and with due respect to his superior officer.

His personal appearance counts for much in his progress while training, and also while serving in the Merchant Marine. It is important therefore, in order to obtain rapid promotion, to have careful regard for one's personal appearance.

The clothing of an apprentice should always be clean, shoes polished, buttons in place on coat and trousers, and when dressed for shore duty the apprentice should present a trim and clean cut appearance, thereby reflecting credit upon himself and the profession of which he is a part.

Facilities are provided on shipboard for frequent bathing, shaving, and also for washing of clothing at regular prescribed periods in the day's occupation. No excuse will be accepted for untidiness on shipboard, and the apprentice who is in earnest will realize the importance of these simple requirements.

All clothing provided an apprentice while in training is Government property and must be returned upon completion of course in as good condition as when received, reasonable wear and tear excepted. If clothing shows indications of abuse beyond ordinary wear and tear, deduction from wages due will be made to cover cost of each article. If an apprentice so desires, he may purchase any or all articles of clothing at cost, and apprentices are advised, if possible, to avail themselves of this opportunity.

The clothing will be useful not alone while the apprentice is serving in the Merchant Marine, but will mark the wearer in a distinctive manner as one who is serving his country in a glorious occupation.

In going to meals, apprentices should present a neat appearance. This provision applies also to officers and instructors, no one being permitted to appear at table untidy or improperly clothed.

SEAMANSHIP

BELL TIME ON SHIPBOARD

The twenty-four hours are divided on board ship into seven parts, and the crew is divided into two parts or watches, designated Port and Starboard Watches. Each watch is on duty four hours, except from 4 to 8 P. M., which time is divided into two watches of two hours each, called Dog Watches, by means of which the watches are changed every day, and each watch gets a turn of eight hours' rest at night. **First Watch**, 8 P. M. to midnight; **Middle Watch**, midnight to 4 A. M.; **Morning Watch**, 4 to 8 A. M.; **Forenoon Watch**, 8 A. M. to noon; **Afternoon Watch**, noon to 4 P. M.; **First Dog Watch**, 4 to 6 P. M.; **Second Dog Watch**, 6 to 8 P. M. In the French service there are no Dog Watches, but there are two watches of 6 hours each.

THE BELL IS STRUCK EVERY HALF HOUR TO INDICATE THE TIME

1 Bell,	12.30 A. M.	5 Bells,	6.30 A. M.	1 Bell,	12.30 P. M.	1 Bell,	6.30 P. M.
2 Bells,	1.00 "	6 "	7.00 "	2 Bells,	1.00 "	2 Bells,	7.00 "
3 "	1.30 "	7 "	7.30 "	3 "	1.30 "	3 "	7.30 "
4 "	2.00 "	8 "	8.00 "	4 "	2.00 "	4 "	8.00 "
5 "	2.30 "	1 Bell,	8.30 "	5 "	2.30 "	1 Bell,	8.30 "
6 "	3.00 "	2 Bells,	9.00 "	6 "	3.00 "	2 Bells,	9.00 "
7 "	3.30 "	3 "	9.30 "	7 "	3.30 "	3 "	9.30 "
8 "	4.00 "	4 "	10.00 "	8 "	4.00 "	4 "	10.00 "
1 Bell,	4.30 "	5 "	10.30 "	1 Bell,	1.30 "	5 "	10.30 "
2 Bells,	5.00 "	6 "	11.00 "	2 Bells,	5.00 "	6 "	11.00 "
3 "	5.30 "	7 "	11.30 "	3 "	5.30 "	7 "	11.30 "
4 "	6.00 "	8 "	12.00 noon.	4 "	6.00 "	8 "	12.00 night.

TO MARK A LEAD LINE

The hand lead has nine marks and eleven deeps, and is marked to twenty fathoms, as follows:

- 2 fathoms, two strips of leather.
- 3 fathoms, three strips of leather.
- 5 fathoms, white cotton rag.
- 7 fathoms, red woolen rag.
- 10 fathoms, leather with one round hole.
- 13 fathoms, same as three.
- 15 fathoms, same as five.
- 17 fathoms, same as seven.
- 20 fathoms, leather with two round holes.

The deep sea lead is marked the same as the hand lead up to twenty fathoms, then a plain mark for 25 fathoms, 3 knots for 30 fathoms, plain mark for 35, four knots for 40 fathoms, etc., and every ten fathoms with two knots up to one hundred fathoms which is marked with a piece of leather.

Some marks are woolen rags and some are cotton rags that they may be distinguished at night by putting the mark in the mouth.

A lead line should be of material similar to that used for log lines, and while being marked, must be thoroughly wet.

How to Report the Soundings.

In reporting or calling the soundings the leadsmen should always make the number of fathoms the last part of the call. This is seamanlike and is an advantage to the officer on watch as he will generally get the number of fathoms even though through wind or other causes the first two or three words are not clearly understood.

The following is the order in which the report should be made:

At a depth of five fathoms—by the mark five.

At a depth of $5\frac{1}{4}$ fathoms—and a quarter five.

At a depth of $5\frac{1}{2}$ fathoms—and a half five.

At a depth of $5\frac{3}{4}$ fathoms—a quarter less six.

At a depth of 6 fathoms—by the deep six.

At a depth of $6\frac{1}{4}$ fathoms—and a quarter six.

At a depth of $6\frac{1}{2}$ fathoms—and a half six.

At a depth of $6\frac{3}{4}$ fathoms—a quarter less seven.

At a depth of 7 fathoms—by the mark seven.

In learning to heave the lead the marks and deeps should be memorized. No difficulty will then be experienced in reporting the cast.

THE SOUNDING MACHINE.

For sounding purposes there is, in common use, a machine consisting of a drum or spool upon which is wound a quantity of fine steel wire. This wire is made fast to the link which is attached to the lead and may be allowed to run out freely or may be reeled in by the proper use of handles attached to the machine.

About a half turn of the crank in one direction slacks the drum, while the turning of the handle in the opposite direction sets the brake and checks the wire from running out.

The depth of water may be determined by means of a depth recorder which has a gauge and indicator, or by means of glass tubes, the insides of which are treated with a chemical preparation. The glass tube is protected by a brass case, the tube being open at the bottom and attached to the lead. As the lead descends, water is forced into the tube according to pressure comparable with the depth attained. The salt water discolors the chemical coating showing how far the water enters the tube. The discolored portion of the tube measured by a scale, gives the depth. In addition the machine has a clocklike dial which records the length of wire reeled out. This does not, however, give the accurate depth of water and serves only as a check upon the cast.

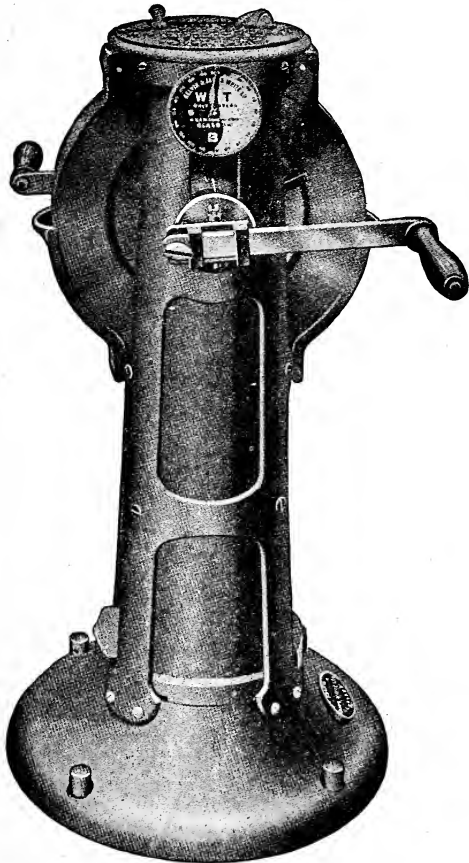

The Sounding Machine.

LOCATION OF SOUNDING MACHINE.

Select the most convenient place on the taffrail and make the fair-lead fast to the rail. The machine is placed about 12 feet away from the fair-lead and made fast to the deck by means of screws which pass through its base.

Note—The fair-lead is a pulley over which the wire passes.

METHOD OF OPERATION.

After the machine is placed and the handles attached, the arm is made fast by turning the catch around and the brake is set to prevent the wire running out. The depth recorder or the chemical tube is then adjusted and made fast to the ropes between the link and the sinker, and the wire made fast to the link.

The attachments are then carefully lowered overboard by hand, and the wire placed in the fair-lead with the link hanging just clear. The wire is then taut and the register on the machine should indicate zero.

When ready to make a cast, a slight turn of the handle will unship the brake, and the wire is controlled by pressing upon it by the finger-pin which shows when bottom is reached by a slackening of the wire under pressure of the pin.

THE INDICATOR.

Watch carefully and gradually apply the brake before all the wire has passed off the drum or bottom has been reached, then reverse the motion of the drum and re-wind the wire, guiding it inboard by hand with a piece of waste canvas. Watch until the link is close to the fair-lead and then bring the depth-recorder inboard by hand, carefully keeping it upright until read.

The speed at which the ship is moving determines the length of wire in excess of depth of water required to reach bottom, and great care must be exercised to avoid looping or slacking of the wire and to prevent kinks forming.

A kinked wire is practically destroyed as a slight pull will break it.

KNOTS AND MILES

There is a growing practice of making an improper use of the word knot, not only with landsmen, engineers and shipbuilders, but also with those who should know better. The prevailing idea appears to be that a knot is the same as the geographical, nautical or sea mile, and that the word "knot" is used to avoid possible confusion with the statute land mile. But this is quite wrong. The knot is the cosmopolitan unit of speed, employed at sea by sailors of all civilized nations. One knot is a speed of one nautical mile an hour, the nautical being the mean sexagesimal minute of latitude on the earth's surface, so that it is $90 \times 60 = 5,400$ miles from the equator to the pole, and this is the only mile the sailor knows or uses. A nautical or Admiralty measured mile (we do not say an Admiralty knot) is slightly more than 6,080 feet so that one knot is a speed of a little more than 100 feet a minute, more nearly 101 to 102 feet a minute; thus, on a log line, with a half minute glass or interval of time, the distance between the knots should be 50 feet or a little over, say 51 feet. The word knot is derived from the knots on the log line; the number of knots that pass over the ship's taffrail during the half minute or other interval of time gives the speed of the ship in knots. The only occasion then in which it is permissible to use the word knot as the equivalent of a length is in tracing the knots on the log line, and then by a familiar tendency in language, the "distance between two knots" is abbreviated in speech to the "length of a knot." By a curious perversity and straining after precision, the incorrect expression "knot an hour," to express the speed of a ship, is creeping into general use, with the effect of displacing the word mile by knot. No real sailor would say that a rock on the land was half a knot, one knot, etc., away. It is too often urged that the expression "knots an hour" is so much clearer and more definite: but we might just as well measure pressure in "atmospheres per square inch."

STEERING ORDERS

- Close Hauled**—Same as "Full-and-By."
Ease Her—To let the vessel go off a little from the wind.
Full-and-By—As close to the wind as the vessel will lay and keep her sails full.
Helm Down—To bring the vessel nearer the wind.
Helm Up—To let the vessel go off from the wind.
Make the Course Good—When running before the wind and yawing, to manage the helm so that the vessel will deviate as much on one side of the course as on the other—the middle point being the course given to the helmsman.
Meet Her—To reverse the helm and check the swing of the vessel's head.
No Higher—Not to bring the vessel any closer to the wind.
Nothing Off—Not to allow the vessel to go any more off from the wind.
Pinch Her—To put the wheel down sufficiently to shiver the sails.
Rap Full—To keep away from the wind enough to make all the sails draw well.
Steady—To hold the vessel as she pointed when the order was given.
Port Helm—To put helm towards the right hand or starboard side of ship.
Starboard Helm—To put helm towards the left hand or port side of ship.

INTERNATIONAL RULES.

PILOT RULES.

The international rules for preventing collisions at sea are to be followed by all public and private vessels of the United States upon the high seas and in all waters connected therewith, navigable by seagoing vessels, except so far as navigation of inland waters is governed by the inland rules.

These rules govern the movement of vessels by day and night with special reference to meeting and passing each other, the signals to be exchanged; the lights to be carried and the speed in fog, mist, falling snow or heavy rain storms.

The international rules have been prepared at International Conferences and agreed to by the principal maritime nations and are applicable on inland waters, unless special rules exist to the contrary duly made by local authority.

In the United States, special rules known as the inland rules are enacted by Congress, which govern the movement of vessels upon inland waters such as bays, harbors, rivers, lakes and sounds and are to be followed upon such waters that are highways of commerce or open to general or competitive navigation.

In addition to the inland rules enacted by Congress, there will be found in the "Pilot Rules" a set of regulations established by the Board of United States Supervising Inspectors, Steamboat Inspection Service, by authority of Congress. These are to be followed, unless found to be at variance with the inland rules, in which case, the courts have given precedence to the inland rules.

Inland waters are defined in the "Pilot Rules" of the Atlantic and Pacific Coast and Gulf of Mexico, by boundary lines which divide the inland waters from the high seas, and upon them the inland rules apply.

The inland rules are divided in three parts, as follows:

Rules for certain inland waters of the Atlantic and Pacific Coasts, and of the Coast of the Gulf of Mexico; Rules for the Great Lakes and their connecting and tributary waters as far East as Montreal; Rules of the Red River of the North and rivers flowing into the Gulf of Mexico.

They are somewhat similar and closely related to each other, the inland rules containing more detailed provisions for navigation of narrow and crowded waters and the language used throughout is clear and easily comprehended.

Keeping the lookout when the vessel is underway is one of the duties of a seaman aboard a merchant-ship. The lookout is stationed at or near the bow of the vessel, between the hours of sunset and sunrise; also when the weather is foggy, and when entering or leaving port.

It is therefore very essential to become familiar with the rules in order to report your observations intelligently to the officer on the bridge and thereby assist in the navigation of the vessel. Should a collision occur between your vessel and another, while you are on lookout, you will be called as one of the principal

witnesses at the trial of the licensed officers, before the U. S. Local Inspectors and again in the Federal Court, should suit be brought by the owners of either of the vessels. If you are not familiar with the rules, it may result in your testimony being considered as valueless and this may result in the officer losing his license and at the same time his livelihood, while the owner of your vessel would doubtless lose his suit for damage against the other vessel. You will, therefore, realize how important it is that you should learn these rules by heart, and understand fully their meaning and their relation to each other.

It is a good plan when off duty to discuss the rules with your shipmates, drawing diagrams of the positions of vessels meeting and passing; the proper rule to be observed in each case; and the signals to be made. If a doubt exists on any question, appeal to an officer of your ship for a decision and explanation. It will not alone be helpful to you and your shipmates, but helpful to the officer, for in this way many points are brought out to the advantage of all concerned.

RULES OF THE ROAD AT SEA

Red



White



Green



1. **Two Steamships meeting end on, or nearly end on.**

Meeting Steamers do not dread
When you see three lights ahead!
Port your helm and show your Red.

2. **Two Steamships passing.**

For Steamers passing you should try
To keep this maxim in your eye:
Green to Green, or Red to Red—
Perfect safety—go ahead.

3. **Two Steamships crossing. This is the real position of danger.**

The steamship that has the other on her own starboard side shall keep out of the way of the other.

There is nothing for it but good lookout, caution and judgment.

If to Starboard Red appear,
'Tis your duty to keep clear;
Act as judgment says is proper—
Port on Starboard, back or stop her!
But when on your port is seen
A steamer with a light of Green,
There's not so much for you to do—
The Green light must keep clear of you.

4. **All ships must keep a good lookout, and Steamships must stop and go astern, if necessary**

Both in safety and in doubt
Always keep a good lookout;
Should there not be room to turn.
Stop your ship and go astern.

WINDS AND SOUND SIGNALS

Wind is air in motion. The direction of the wind is designated by the point of the compass from which it blows. All winds are caused directly or indirectly by changes of temperature. If two neighboring regions become very unequal in temperature from any cause, the air of the warmer region, being lighter than the other, will ascend and be poured over it from above, while the heavier air of the colder region will flow in below to supply its place. The rotation of the earth alone produces no permanent wind because the atmosphere has the same velocity of rotation as that of the portion of the earth upon which it rests, but the earth's rotation materially modifies the operation of other disturbing causes.

Velocity Per Hour	Designation
Up to 2 miles.....	Calm.
“ 7 “	Light air.
“ 11 “	Light breeze.
“ 16 “	Gentle breeze.
“ 20 “	Moderate breeze.
“ 25 “	Fresh breeze.
“ 29 “	Strong breeze.
“ 35 “	Moderate gale.
“ 42 “	Fresh gale.
“ 49 “	Strong gale.
“ 57 “	Whole gale.
“ 66 “	Storm.
“ 79 “	Hurricane.

Sound is conveyed in a very capricious way through the atmosphere. Apart from wind, large areas of silence have been found in different directions and different distances from the signals, in some instances even when in close proximity to the sound signal. The mariner should not assume—

1. That he is out of ordinary hearing distance because he fails to hear the sound.
2. That because he hears a fog-signal faintly, he is a great distance away from it.
3. That he is near it because he hears the sound plainly.
4. That the distance from and the intensity of the sound on any one occasion is a guide to him for any future occasion.
5. That the fog-signal has ceased sounding because he does not hear it even when in close proximity.

WIND FORCE

Beaufort's Scale

	Velocity Miles per Hour
0—Calm. Full rigged ship, all sails set, no head-way	3
1—Light Air. Just sufficient to give steerage way	8
2—Light Breeze. Speed of one or two knots, “full and by”	13
3—Gentle Breeze. Speed of three or four knots, “full and by”	18

4—Moderate Breeze. Speed of five or six knots, "full and by"	23
5—Fresh Breeze. All plain sail, "full and by"	28
6—Strong Breeze. Topgallant sails over single-reefed topsails	34
7—Moderate Gale. Double-reefed topsails.....	40
8—Fresh Gale. Treble-reefed topsails (or reefed upper topsails and courses)	48
9—Strong Gale. Close-reefed topsails and courses (or lower topsails and courses).....	56
10—Whole Gale. Close-reefed main topsail and reefed fore sail (or lower main topsail and reefed foresail)	65
11—Storm. Storm staysails	75
12—Hurricane. Under bare poles	90

BEAUFORT NOTATION, FORMULA AS USED FOR INDICATING THE DISTURBANCE OF THE SEA

0	Calm.
1	Very Smooth.
2	Smooth.
3	Slight.
4	Moderate.
5	Rather Rough.
6	Rough.
7	High.
8	Very High.
9	Tremendous.

BOXING OF MARINERS' COMPASS

The mariners' compass should be kept as far as possible from the dynamo or any iron work on the ship. Inside the bowl of the compass will be found a vertical line called the "lubber line." This, with the center of the card, indicates the boat's longitudinal center line. Place the "lubber line" towards the bow, and the points on the compass card will indicate the direction the boat is pointing.

The names of the "points" reading in the direction the hands of a watch move are as follows: NORTH, North by East, North, Northeast, Northeast by North, Northeast, Northeast by East, East-Northeast, East by North. EAST, East by South, East-Southeast, Southeast by East, Southeast, Southeast by South, South-Southeast, South by East. SOUTH, South by West, South-Southwest, Southwest by South, Southwest, Southwest by West, West-Southwest, West by South. WEST, West by North, West-Northwest, Northwest by West, Northwest, Northwest by North, North-Northwest, North by West, North.

WATCHES AS COMPASSES

"Point the hour hand of your watch to the Sun and the South is exactly half way between the hour and figure XII. on the watch. For instance, suppose it is 4 o'clock. Point the hand indicating four to the Sun, and the II. on the watch is exactly South. Suppose it is 8 o'clock, point the hand indicating eight to the Sun, and the figure X. on the watch is due South.

THE MARINER'S COMPASS

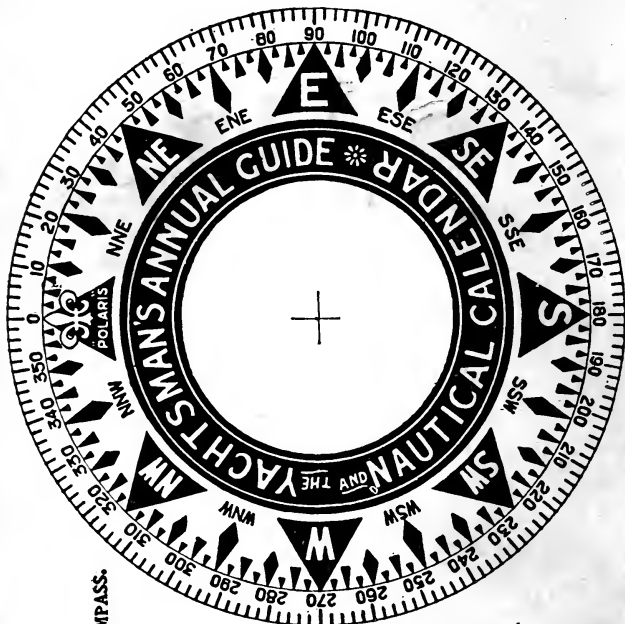

POINTS of the COMPASS.

North
 North by East
 North-East
 North-East by North
 North-East
 North-East by East
 East, North-East
 East by North
 East
 East by South
 East, South-East
 South-East by East
 South-East
 South-East by South
 South, South-East
 South by East
 South
 South by West
 South, South-West
 South-West by South
 South-West
 South-West by West
 West, South-West
 West by South
 West
 West by North
 West, North-West
 North-West by West
 North-West
 North-West by North
 North, North-West
 North by West
 North

POINTS, NUMBER OF POINTS AND FRACTIONS OF POINTS IN THE MERIDIAN.

South		Points
S. $\frac{1}{2}$ E.	S. $\frac{1}{2}$ W.	$\frac{1}{2}$ 20° 48' 45"
S. $\frac{1}{4}$ E.	S. $\frac{1}{4}$ W.	$\frac{1}{4}$ 50° 37' 30"
S. $\frac{3}{4}$ E.	S. $\frac{3}{4}$ W.	$\frac{3}{4}$ 80° 26' 15"
S.-by-E.	S.-by-W.	1 110° 15' —
S.-by-E. $\frac{1}{2}$ E.	S.-by-W. $\frac{1}{2}$ W.	$\frac{1}{2}$ 140° 3' 45"
S.-by-E. $\frac{1}{4}$ E.	S.-by-W. $\frac{1}{4}$ W.	$\frac{1}{4}$ 160° 52' 30"
S.-by-E. $\frac{3}{4}$ E.	S.-by-W. $\frac{3}{4}$ W.	$\frac{3}{4}$ 190° 41' 15"
S.S.E.	S.S.W.	2 220° 30' —
S.S.E. $\frac{1}{2}$ E.	S.S.W. $\frac{1}{2}$ W.	$\frac{1}{2}$ 250° 18' 45"
S.S.E. $\frac{1}{4}$ E.	S.S.W. $\frac{1}{4}$ W.	$\frac{1}{4}$ 280° 7' 30"
S.S.E. $\frac{3}{4}$ E.	S.S.W. $\frac{3}{4}$ W.	$\frac{3}{4}$ 300° 56' 15"
S.E.-by-S.	S.W.-by-S.	3 330° 45' —
S.E. $\frac{1}{2}$ S.	S.W. $\frac{1}{2}$ S.	$\frac{1}{2}$ 360° 33' 45"
S.E. $\frac{1}{4}$ S.	S.W. $\frac{1}{4}$ S.	$\frac{1}{4}$ 390° 22' 30"
S.E. $\frac{3}{4}$ S.	S.W. $\frac{3}{4}$ S.	$\frac{3}{4}$ 420° 11' 15"
S.E.	S.W.	4 450° —
S.E. $\frac{1}{2}$ E.	S.W. $\frac{1}{2}$ W.	$\frac{1}{2}$ 470° 48' 45"
S.E. $\frac{1}{4}$ E.	S.W. $\frac{1}{4}$ W.	$\frac{1}{4}$ 500° 37' 30"
S.E. $\frac{3}{4}$ E.	S.W. $\frac{3}{4}$ W.	$\frac{3}{4}$ 530° 26' 15"
S.E.-by-E.	S.W.-by-W.	5 560° 15' —
S.E.-by-E. $\frac{1}{2}$ E.	S.W.-by-W. $\frac{1}{2}$ W.	$\frac{1}{2}$ 590° 3' 45"
S.E.-by-E. $\frac{1}{4}$ E.	S.W.-by-W. $\frac{1}{4}$ W.	$\frac{1}{4}$ 610° 52' 30"
S.E.-by-E. $\frac{3}{4}$ E.	S.W.-by-W. $\frac{3}{4}$ W.	$\frac{3}{4}$ 640° 41' 15"
S.E.	W.S.W.	6 670° 30' —
S.E. $\frac{1}{2}$ E.	W.S.W. $\frac{1}{2}$ W.	$\frac{1}{2}$ 700° 18' 45"
S.E. $\frac{1}{4}$ E.	W.S.W. $\frac{1}{4}$ W.	$\frac{1}{4}$ 730° 7' 30"
S.E. $\frac{3}{4}$ E.	W.S.W. $\frac{3}{4}$ W.	$\frac{3}{4}$ 750° 56' 15"
S.-by-S.	W.-by-S.	7 780° 45' —
S. $\frac{1}{2}$ S.	W. $\frac{1}{2}$ S.	$\frac{1}{2}$ 810° 33' 45"
S. $\frac{1}{4}$ S.	W. $\frac{1}{4}$ S.	$\frac{1}{4}$ 840° 22' 30"
S. $\frac{3}{4}$ S.	W. $\frac{3}{4}$ S.	$\frac{3}{4}$ 870° 11' 15"
S.	West.	8 900° —

TABLES SHOWING THE NAMES OF POINTS AND QUARTER-COURSE, AND THE ANGLE MADE BY EACH WITH

North		Points
N. $\frac{1}{2}$ E.	N. $\frac{1}{2}$ W.	$\frac{1}{2}$ 20° 48' 45"
N. $\frac{1}{4}$ E.	N. $\frac{1}{4}$ W.	$\frac{1}{4}$ 50° 37' 30"
N. $\frac{3}{4}$ E.	N. $\frac{3}{4}$ W.	$\frac{3}{4}$ 80° 26' 15"
N.-by-E.	N.-by-W.	1 110° 15' —
N.-by-E. $\frac{1}{2}$ E.	N.-by-W. $\frac{1}{2}$ W.	$\frac{1}{2}$ 140° 3' 45"
N.-by-E. $\frac{1}{4}$ E.	N.-by-W. $\frac{1}{4}$ W.	$\frac{1}{4}$ 160° 52' 30"
N.-by-E. $\frac{3}{4}$ E.	N.-by-W. $\frac{3}{4}$ W.	$\frac{3}{4}$ 190° 41' 15"
N.N.E.	N.N.W.	2 220° 30' —
N.N.E. $\frac{1}{2}$ E.	N.N.W. $\frac{1}{2}$ W.	$\frac{1}{2}$ 250° 18' 45"
N.N.E. $\frac{1}{4}$ E.	N.N.W. $\frac{1}{4}$ W.	$\frac{1}{4}$ 280° 7' 30"
N.N.E. $\frac{3}{4}$ E.	N.N.W. $\frac{3}{4}$ W.	$\frac{3}{4}$ 300° 56' 15"
N.E.-by-N.	N.W.-by-N.	3 330° 45' —
N.E. $\frac{1}{2}$ N.	N.W. $\frac{1}{2}$ N.	$\frac{1}{2}$ 360° 33' 45"
N.E. $\frac{1}{4}$ N.	N.W. $\frac{1}{4}$ N.	$\frac{1}{4}$ 390° 22' 30"
N.E. $\frac{3}{4}$ N.	N.W. $\frac{3}{4}$ N.	$\frac{3}{4}$ 420° 11' 15"
N.E.	N.W.	4 450° —
N.E. $\frac{1}{2}$ E.	N.W. $\frac{1}{2}$ W.	$\frac{1}{2}$ 470° 48' 45"
N.E. $\frac{1}{4}$ E.	N.W. $\frac{1}{4}$ W.	$\frac{1}{4}$ 500° 37' 30"
N.E. $\frac{3}{4}$ E.	N.W. $\frac{3}{4}$ W.	$\frac{3}{4}$ 530° 26' 15"
N.E.-by-E.	N.W.-by-W.	5 560° 15' —
N.E.-by-E. $\frac{1}{2}$ E.	N.W.-by-W. $\frac{1}{2}$ W.	$\frac{1}{2}$ 590° 3' 45"
N.E.-by-E. $\frac{1}{4}$ E.	N.W.-by-W. $\frac{1}{4}$ W.	$\frac{1}{4}$ 610° 52' 30"
N.E.-by-E. $\frac{3}{4}$ E.	N.W.-by-W. $\frac{3}{4}$ W.	$\frac{3}{4}$ 640° 41' 15"
N.E.	W.N.W.	6 670° 30' —
N.E. $\frac{1}{2}$ E.	W.N.W. $\frac{1}{2}$ W.	$\frac{1}{2}$ 700° 18' 45"
N.E. $\frac{1}{4}$ E.	W.N.W. $\frac{1}{4}$ W.	$\frac{1}{4}$ 730° 7' 30"
N.E. $\frac{3}{4}$ E.	W.N.W. $\frac{3}{4}$ W.	$\frac{3}{4}$ 750° 56' 15"
N.-by-N.	W.-by-N.	7 780° 45' —
N. $\frac{1}{2}$ N.	W. $\frac{1}{2}$ N.	$\frac{1}{2}$ 810° 33' 45"
N. $\frac{1}{4}$ N.	W. $\frac{1}{4}$ N.	$\frac{1}{4}$ 840° 22' 30"
N. $\frac{3}{4}$ N.	W. $\frac{3}{4}$ N.	$\frac{3}{4}$ 870° 11' 15"
N.	East.	8 900° —

SEIZINGS, HITCHES, BENDS, SPLICES, Etc.
IN EVERY-DAY USE.

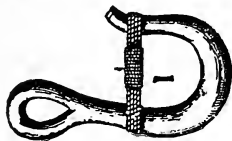

1 Mousing

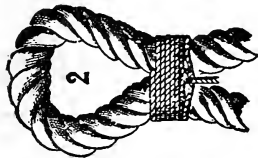

2 Throat Seizing

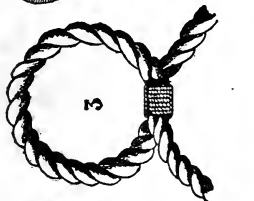

3 Half a Crown



4 Fork and Lashing Eyes

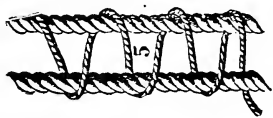

5 Racking



6



7



8



9

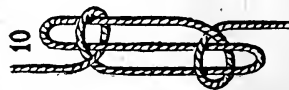

10



11



12

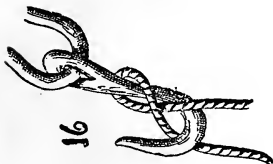
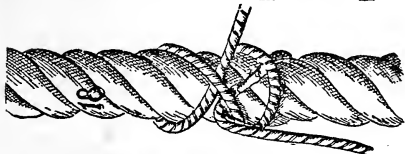
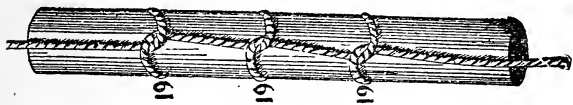

19 Marine Hitch

17 Catspaw
18 Rolling Hitch

15 Bowline on the Right
16 Black Wall Hitch

13 Carrick Bend
14 Bowline Hitch

20 Half Hitch
21 Timber Hitch
22 Clove Hitch

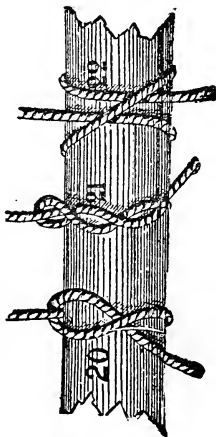

KNOTS, BENDS AND SPLICES

For the Use of

SEAMEN

There is no doubt but that a correct knowledge of how to make the various bends, knots and splices used on board ship, is of essential importance to the sailor whether amateur or professional.

Formerly, when the work of fitting and rigging a vessel was often carried out by the crew alone, such knowledge formed part of the education of every boy sent to sea.

At the present time, with the exception of the most commonly used hitches and bends, sailors as a rule know almost nothing of the art of rigging as practised by our forefathers. This has been brought about chiefly by the use of wire, and also by the fact that most of the work connected with the rigging of a vessel is performed by a special class of men styled riggers, who are regularly trained at the various dockyards for such duty. This is one reason why so many vessels, disabled at sea by loss of their upper spars and gear, return to port to refit, instead, as was formerly the case, of those in charge entrusting the work of repair to the crew, while continuing the voyage.

ROPES

The rigging of a vessel is either standing or running. The standing rigging consists of shrouds and stays, used for supporting the masts, while the running rigging is that used for halliards, sheet, tacks, etc., which, of course, reeve through blocks and sheave holes. The ropes used on board ship are of several kinds. The principal being cable laid, hawser laid and shroud laid rope.

Ropes are made either of hemp, manila, cotton or coir. Wire is also extensively used for standing rigging.

Hemp is best for standing rigging, or running rigging where a heavy purchase is required; manila for light running rigging; cotton for man ropes, ridge ropes, and yoke lines; while coir, or, as it is commonly called by sailors, bass rope, is useful for warps, as it is light and easily handled, as compared with its strength.

Hemp rope is generally tarred, but manila, cotton and coir are not tarred. Formerly, Stockholm tar was the only tar used for hemp rope, because it was thought that coal tar burnt the strands, but experiments of late years have demonstrated that of the two, coal tar is the least injurious.

Ropes are made by twisting several yarns together into strands, each strand containing an equal number of yarns, then laying them up in a spiral form, so that each separate yarn bears an equal strain. The strength of any single rope is the combined strength of each separate yarn, and unless these yarns are very carefully twisted together, so as to bring an equal strain upon each part, the rope is imperfect and untrustworthy. In choosing rope, care should be taken that the strands are smoothly, evenly, and closely laid.

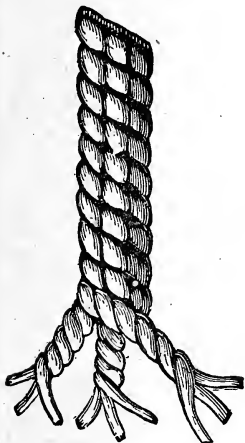

FIG. 1.



FIG. 2.



FIG. 3.

A cable laid rope is composed of three hawser laid ropes, twisted the contrary way, so that it is in fact a nine strand rope.

Figure 1 is a cable laid rope.

A shroud laid rope is a four strand rope, twisted right handed, in the same direction as the course of the sun. See Figure 2.

A hawser laid rope is composed of three strands of yarn, right handed, with the sun. Figure 3.

SPLICING

Having described the different ropes, the next step is to know how to join them together in case of breakage. This can be done either by knotting or splicing. If the rope belongs to the running rigging, which of course implies that it has to reeve through blocks or sheave holes, splicing is necessary, because a knot would present too great an obstacle to the passage of a rope through the sheave hole of a block. Begin with a short splice, as this is most commonly used, where time is to be considered.

We will suppose it is a hawser laid rope which is being operated upon. Take the two severed ends of the rope, unlay the strands to the distance of twelve inches or more, and bring the two ends of the rope together, as in Fig. 1 on next page.

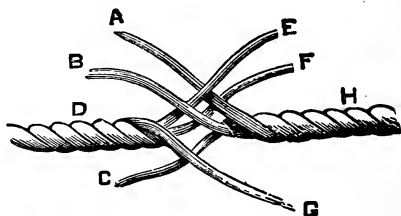

FIG. 1.

SHORT SPLICE.

Take the rope and hold it in the left hand, also the strands A, E, C. Take the strand E, and having passed it over A, tuck it through under strand C, of rope H, haul it taut. Proceed the same way with strand G, passing it over B and under A, finishing with strand F, which is treated the same way, passing it over the strand first next to it, and under the second. Turn the rope around, and do the same with the other side; then the splice will be like Fig. 2.



FIG. 2.

SHORT SPLICE—Continued.

This is not, however, sufficient for strength, so the whole process must be repeated on both sides, and if a very neat splice is required, the ends of the strands may be tapered by being scraped with a knife. A marling-spike must be used to open the strands for the second passing, as this has not been previously untwisted.



FIG. 3.

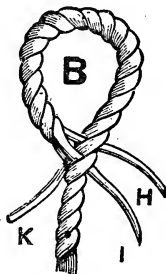

FIG. 3.

An Eye Splice, Fig. 3, is made by opening the end of a rope, and laying the strands E, F, G, at the required distance upon the standing part to form the eye. See A. The strand H is tucked through the strand next to it, having previously opened it with a marling-spike. Strand I is taken over the same strand and through the second, and strand K through the third on the other side.

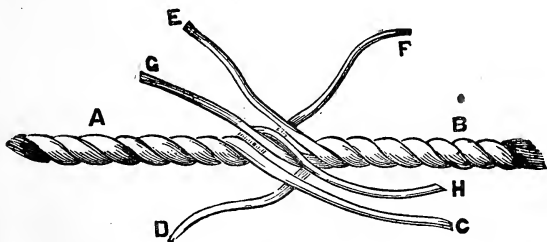

FIG. 4.

A Long Splice, Fig. 4, is the most effective of all splices, but it requires more time than the short splice. It is made thus: unlay the ends to be joined some two or three feet, according to the size of the rope. Place the two ends together as for a short splice.

Unlay strand C and lead it back to A, then take D and lay it up in the space left by C. Do this with the strand E and F on the opposite side. The rope now presents the appearance of Fig. 5.

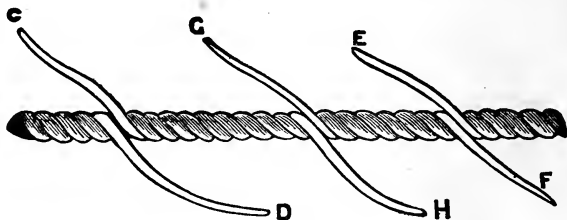

FIG. 5.

The two middle strands, G and H, must now be knotted together with an overhand knot, thus—



Fig. 6

taking care that the knot is made so that the ends follow the lay of the rope, and not across it—Fig. 6. Then divide the strands in halves, and pass them over one strand and under two, or, under one forward and one back. The strands E and F and C and D are treated in the same way. Tuck them through two or three times, stretch the splice well and then cut the ends off close.

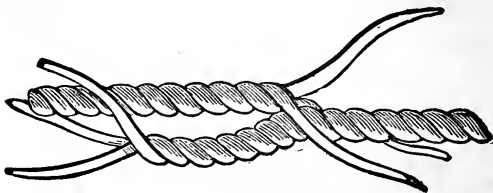

FIG. 7.

A Cut Splice is made the same as the eye splice, only with two ropes instead of one. See Fig. 7.

KNOTS AND BENDS

The knot most commonly used next to an Overhand Knot, already described, is that known as the Reef Knot, from its being always used to tie the reef points of a sail. First take an overhand knot, and then pass the ends so that they take the same lay as the crossed parts of the overhand knot, as Fig. 8. Unless this is done the knot will form a granny or lubber's knot.



FIG. 8.



FIG. 9.

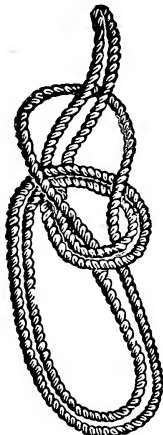

FIG. 10.



FIG. 11.

A Bowline Knot.—Hold the end of the rope in the right hand, and the standing part in the left. Lay the end over the standing part, turn the bight of the standing part over it, so that it forms a loop with the end through. Lead the end around the standing part above the loop so made, and bring it down as in Fig. 9.

Bowline on a Bight.—Proceed as for a single bowline, the bight in the right hand, the standing part in the left. Now take the bight around the standing part, and pass it over the larger bight and haul taut, it will then be like Fig. 10.

Running Bowline.—Take the end of a rope around the standing part, and make a single bowline knot on its own part, as in Fig. 11.

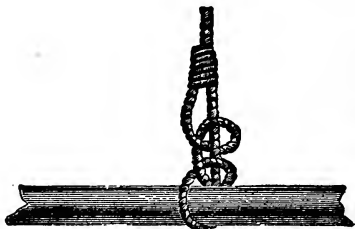

FIG. 12.

Two Half Hitches.—This is a very simple way of making a rope fast in a hurry, where a long-continued strain is not expected, such as a boat's painter. Pass the end of the rope around the standing part, and bring it up through the bight. This is a half hitch; repeat the process and draw taut. If the hitch is to bear a great strain, lash the end to the standing part with spun-yarn, as in Fig. 12. This is sometimes called a clove hitch.



FIG. 13.

Fig. of 8 knot is very simple, the sketch Fig. 13, explains itself.

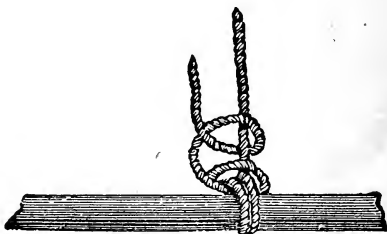

FIG. 14.

A Fisherman's Bend, Fig. 14, is sometimes used for bending on the gaff topsail halliards in a yacht, or topmast stunsail halliard in a square-rigged craft. It consists of two round turns around the spar, a half hitch around the standing part, and under the turns on the spar, then half hitch the end around the standing part.

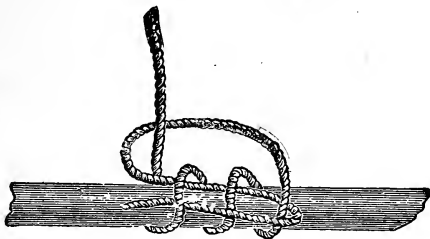

FIG. 15.

Another bend used by Yachtsmen is called the Topsail Halliard Bend, Fig. 15. This is made by taking two turns around the spar, then leading the end back around the standing part and underneath all the turns, bringing it around to its own part and back again over the two outer turns, and underneath the inner turn.

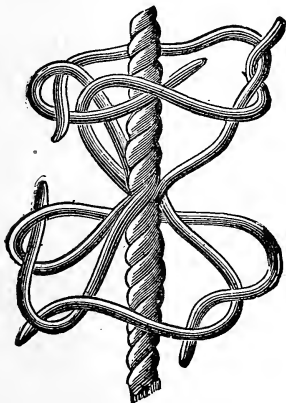

FIG. 16.



FIG. 17.

A Shroud Knot.—This is a knot used for joining a shroud or stay that has been carried away.

Take the two severed ends, unlay them the same as for a short splice. Place them together closely, take the outside strand of the lower part and pass it around the upper part in a loop. Take the next lower strand, pass it under and up through the bight of the first-named strand, then take the end of the next lower strand,

pass it around the end of the first strand, outside of the second strand, and up through the bight of the first strand, draw hand taut, and do the same with the other part. Fig. 16 shows how to pass the strands. Fig. 17 shows the knot completed. The ends of the strands may be marled and served to make a neat job.

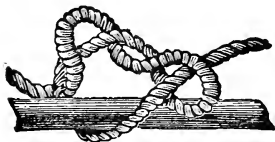

FIG. 18.



FIG. 19.



FIG. 20.

A Timber Hitch, Fig. 18, is made by passing the end of a rope around a spar or timber head, leading it up under and over the standing part, and passing a couple of turns around its own part.

A Cat's Paw, Fig. 19.—Take the end of a rope, lay it over the standing part, making a loop with the bight, form another loop, turn the two loops over from you two or three times, bring the two loops together, and put the hook of a tackle through the two loops.

A Blackwall Hitch, Fig. 20, is used sometimes for the same purpose as the before-mentioned hitch. The Fig. explains itself, the underneath part being jammed by the strain.



FIG. 20 A.



FIG. 20 B.

A Sheet Bend, Fig. 20 A.—Make a bight with one rope, then pass the end of another rope through the bight, and around both parts of the first rope A, and underneath its own part. This is generally used for bending one rope to another when in a hurry. If taken around again, and through the bight again it holds better and is less liable to jamb—see Fig. 20 B.

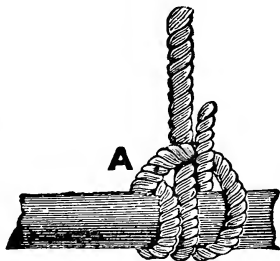

FIG. 21.

A Magnus Hitch, Fig. 21.—Pass two round turns with the end of a rope over a spar, then take it before the standing part, pass it again under the spar and up through the bight A. This is often called a Rolling Hitch. Its great value is its non-liability to slip in the direction of A.



FIG. 22.



FIG. 23.

A Midshipman's Hitch, Fig. 22 and 23.—This is a very old-fashioned hitch. It is generally used to hitch a tail block on to a rope. Take the end of the rope around the standing part and half hitch to the same; then take another turn through the bight and haul taut, then it will appear like Fig. 23.

A Carrick Bend, Fig. 24.—Take the end of a rope and make a bight with the end over the standing part. Pass the end of another rope through the bight over the standing part of the first rope at A, and under the end B, and again through the bight over its own standing part C. Haul taut. This is generally used for bending hawsers together.

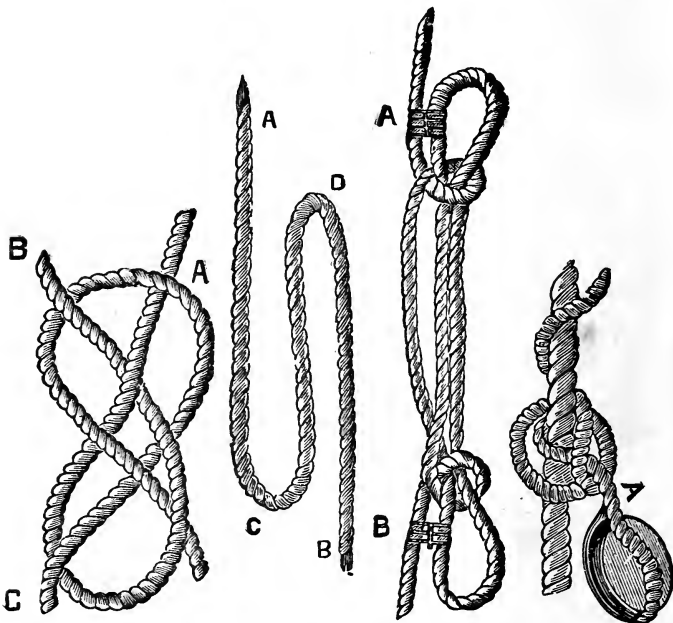

FIG. 24.

FIG. 25.

FIG. 26.

FIG. 27.

A Sheepshank, Figs. 25 and 26.—This is a quick and ready way of shortening a rope. Double the slack rope and lay it in parallel lines, as in Fig. 25. Then take a half hitch with the Fig. 25 standing parts A and B around the bights C and D and it will be like Fig. 26. A seizing of rope yarn around the bights and standing part at A and B, Fig. 26, makes it more secure.

Rolling Hitch, Fig. 27.—This is a hitch used for stoppering a rope, and is a very good method of clapping a tail block on to a reef tackle. Take a hitch with the tail or stopper around the rope, then take another hitch over the first, passing the end under the standing part A, then twist the end around the rope, with the lay.

FANCY KNOTS

These are used for the ends of lanyards, man and ridge ropes, yoke lines, etc. First is the Wall knot, Figs. 28 and 29. Unlay the end of a rope, and with the strand A, Fig. 28, form a bight, hold it down at the side B, pass the end of the next, C around A, the end of strand D around C and through the bight of A, haul taut and the knot is made as in Fig. 29.

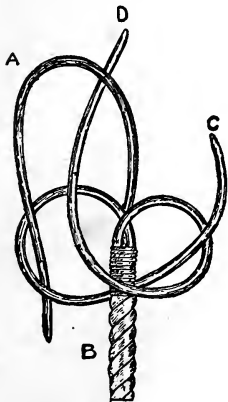

FIG. 28.

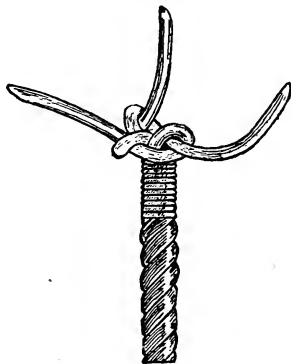

FIG. 29.

WALL KNOT

This can be crowned by taking strand A, Fig. 30, and laying it over the top of the knot. Then lay B over A, and C over B, and through the bight of A and haul taut. This is called a single crown.

A double wall and double crown is made by letting the strands follow their own parts around, first walling and then crowning, as in Fig. 31. Be careful to put a whipping around the rope when the strands are opened out, as in Fig. 28. This is also called a **Stopper Knot**. If crowned first and then walled, it is a "Man Rope Knot."

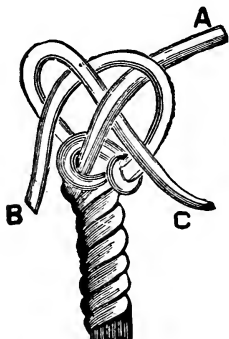

FIG. 30.



FIG. 31.



FIG. 32.

Matthew Walker Knot, Fig. 32.—Open the strands as for a small knot. Take the end A around the rope and through its own bight, the strand B underneath through the bight of A, and through its own bight, and the strand C underneath through the bights of strands A and B, and haul taut. This knot is mostly used for the ends of lanyards.

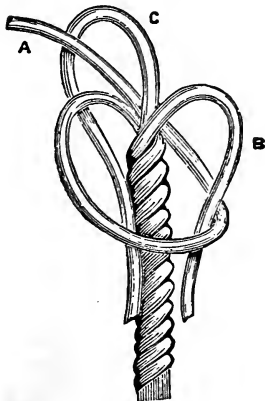

FIG. 33.



FIG. 34.



FIG. 35.

A Diamond Knot, Figs. 33 and 34.—Unlay the end of the rope rather more than for a Matthew Walker Knot, and form three bights of the strands, holding them down as in Fig. 33. Then take strand A over strand B and through the bight of strand C, take strand B over C and through the bight of A and C over A, and through the bight of B, haul taut, and lay the strands up again. The knot appears as in Fig. 34.

A double diamond knot is made by leading the strands through two single bights, the ends coming out at the top of the knot, and leading the last strand through two double bights. Then lay the strands up as before, when it will be like Fig. 35.

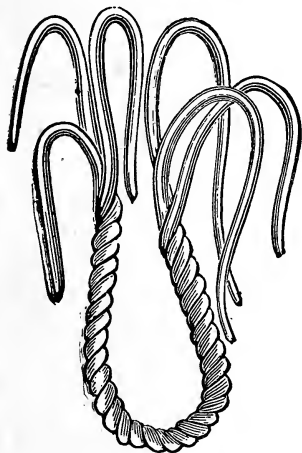

FIG. 36.

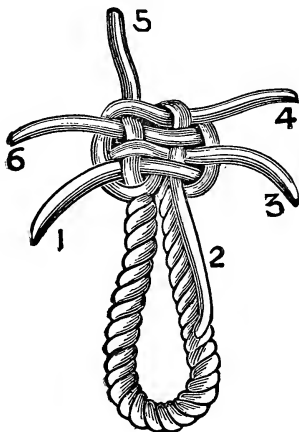

FIG. 37.

Sprit Sail Sheet Knot, Figs. 36 and 37.—This is made by unlaying the two ends of a rope, placing the two parts together, making a bight with strand 1. Proceed to make a Wall knot with the strands, precisely as a single wall knot is made with three strands, putting the second over the first strand, the third over the second, fourth over the third, fifth over the fourth, the sixth over the fifth, and through the bight made by the first, and haul taut. It is crowned by taking two strands across the top of the knot, passing the other strands alternately under and over these two. To double wall, pass the strands after crowning, beginning with 1, under the bights or wallings, as they are called by sailors, on the left of them, and through the same bights, when the ends will come up for the second crowning. To do this, follow the lead of the first crowning, the same as directed with three strands. This knot is often used as a stopper knot in the Navy and Merchant Service. Remember to wall against the lay of the rope. Thus, for a hawser laid rope, wall from right to left.

A Stopper Knot, Fig. 38, is simply double walling, without crowning, a three strand rope against the lay, and whipping the ends of the strands as in Fig. 38.

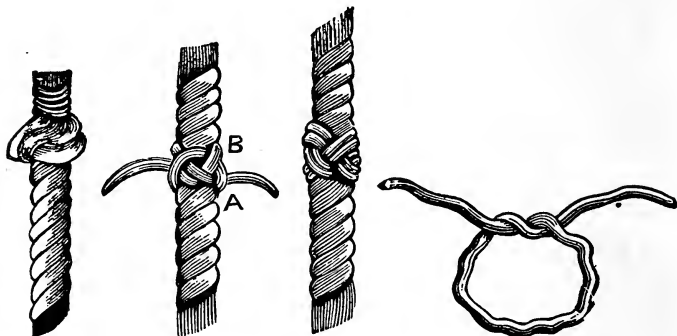

FIG. 38.

FIG. 39.

FIG. 40.

FIG. 41.

Turk's Head, Fig. 39 and 40, is an ornamental knot for man ropes, yoke lines, ridge ropes, etc. With signal halliard, or log line, take a clove hitch around the rope to be ornamented, bring the bight A under the bight B, Fig. 39, and take the end up through it, make another cross with the bights, and take the end down and it will be like Fig. 40. This is a Turk's head of two lays. It may have three, or more, according to taste, by following the lead around, as already described.

A Grommet, Fig. 41, is made out of a single strand of rope; bring the two ends together, forming a ring the size wanted. Lay up one end, twisting it in and out, when it meets the outer end take an overhand knot and tuck the ends through the strands, as in the long splice. Used for block strops, handles of sea chests, snorter for a sprit, etc. They may be parcelled and served, if wanted to look very neat.



FIG. 42.

To Lengthen a Rope for the Head and Foot of a Sail, Fig. 42. —Sometimes it is necessary to give an extra cloth, and as it is not always convenient to send the sail on shore to have this done, it is well to know how to do it. Most vessels have a spare bolt or two of canvas, and there is always some one among the crew

who understands how to handle a palm and needle. Strip the canvas off four cloths; if it is a 3-inch rope allow 2 feet for splicing, which, with the width of the cloth, inclusive of seams, will be ample. Cut the strands at equal distances apart, at the places marked A, B and C; Fig. 42. Take strand A, and unlay it to C. Then take strand B, and unlay it to C. It is better to count the lays or twists, so as to avoid cutting the same strand twice;

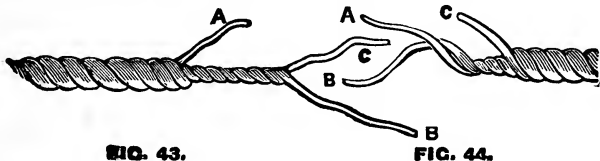

C strand should be cut last. Now draw the rope apart, as in Figs. 43 and 44. Marry the strand A, Fig. 43, to the strand C, Fig. 44, then lay up the strand B, Fig. 43, in the lays of strand A, Fig. 43, and it will present the appearance of Fig. 45. Take a strand a little over three times the length of the width of the cloth of the sail, and marry one end to the strand A, and lay it up in the space left by A and C, and marry the other end to strand C. Then splice all the ends, as in a long splice, whip the ends of the strands, and cut off within about an inch of the rope. Stretch the splice well before cutting the ends of the strands. A good rule is to take eight times the circumference of the rope for splicing, that would be about four times each side of the centre strand that has to be cut. This is in addition to the width of the extra cloth. Marrying two ends of a rope or strand, is merely sewing them together with sewing twine.

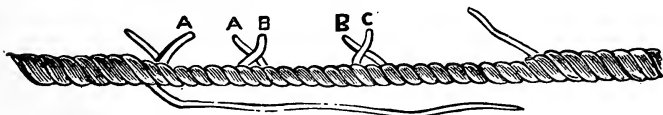

Putting a New Strand in a Rope, Fig. 46.—This is necessary when a strand is chafed through in the one part while the rest of the rope is good. Cut the strand at the chafe, unlay it a couple of feet each way, then take a new strand, same size rope, and lay up in the place of the old strand. Take an overhand knot with ends and tuck them in as in a long splice.



To Splice a Three and Four Strand Rope Together.—Unlay a long splice, one strand of the three strand rope, and fill up the space with one of the strands of the four strand rope, then unlay a strand of the four strand rope, and lay in the space a strand of the three strand rope to the distance wanted. Then you have two strands of the four strand rope, and one of the three strand rope left. Divide the single strand in two, and knot it to one of the strands of the four strand rope. Unlay the other strand and fill in with the other half of the divided strand, knot them together and tuck them in as in an ordinary long splice. Always stretch a splice well before cutting the ends of the strands projecting when finished.

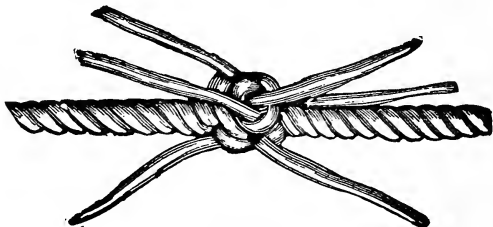

FIG. 47.

French Shroud Knot, Fig. 47.—This is a neat way of making a shroud knot. It is done by crowning backwards, or left handed, the strands of each end, then pass the ends as they lie from you, to the left of those that fall down towards you, haul taut, and they will appear as in Fig. 47. The ends may be either tucked in as in splicing or can be scraped, marled down, and served as fancy dictates.

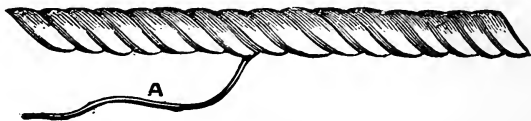

FIG. 48.

Worming a Rope, Fig. 48.—This is done by winding spunyarn into the space between the strands, so as to make it smooth.

Serving and Parcelling, Fig. 49, is done to prevent a rope from being chafed. Strips of old canvas are first tarred, and then wrapped around with the lay of the rope, the whole being kept in its place by placing marling or spunyarn around the parcelling, and hitching each turn, as C in Fig. 49. The serving mallet is laid with its groove on the rope, a turn is taken with the spunyarn around the rope and head of the mallet around the side next you, and two turns around the other side, and twist it around the handle; get another hand to pass the ball A around the rope, while you heave around the mallet. The four last turns of the service must have the end of the spunyarn put through them and hauled taut, which secures it.

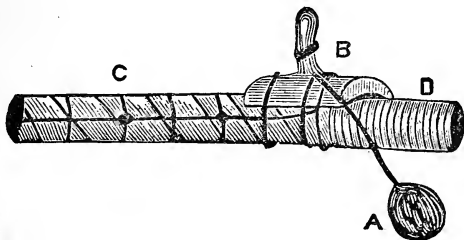

FIG. 49.

Pointing a Rope, Fig. 50.—Whip the rope about 6 or 8 inches from the end, according to its size. Unlay the strands, and open out the yarns, take the inside yarns and form what is called the heart. The outside yarns must be turned down, and the heart scraped off towards the end with a knife, and then marled down.

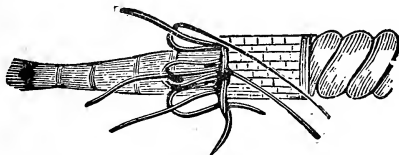

FIG. 50.

Then take the outside yarns and lay them one up and one down alternately, knot the filling with a timber hitch over the upper ones, take a couple of turns and pass the end between both, to jamb it before hauling the last turn taut, then bring the upper yarns down, and lay the lower ones up; pass the filling, and proceed as already described, hauling the yarns taut after each round, and passing the first turn of the filling under one or two of the upper ends in advance each time, instead of over them. This hides the hitch when brought up. In finishing off, securely hitch the lower yarns. Cut the upper ones off, and the lower ones after you have taken two turns of the filling. Haul the bight of the yarns close down, and hammer the point well after every turn, to make it smooth and flat.



FIG. 51.

A **Selvagee Strop**, Fig. 51, is made by laying a number of rope yarns in a bight and then keeping them together with spunyarn or marling wound around as above.

Seizing.—To fasten ropes or different parts of rope together, by winding rope yarns, marling or spunyarn around them. Blocks are generally stropped with a round seizing.



FIG. 52.



FIG. 53.

To Make a Round Seizing, Figs. 52 and 53.—Make a slip knot in one end of the marling or spunyarn, take a turn around the two parts of the rope you want to nip together, pull it well taut, using your marling-spike as a lever, by winding the spunyarn around it and drawing it back with the point of the spike against the rope, take six, eight, or nine turns, according to size of rope, then tuck the end through the last turn, Fig. 52, then take five or six turns over the others; these are called riders, and should be one less turn than those underneath. Tuck the end of the spunyarn up through the seizing, and take a couple of cross turns between the rope around the seizing, and jamb and knot the end, after heaving it well taut, as Fig. 53. When this seizing is on the two ends of a rope it is called an **End Seizing**. If upon the bight, Fig. 53, an **Eye Seizing**.

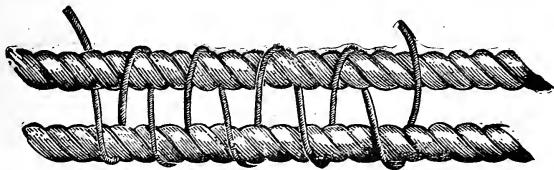

FIG. 54.

Racking or Nippering, Fig. 54, is used to jamb the two parts of a tackle fall together when the purchase wants lengthening, or nautically, "fleeting." It is made by cross turns, and then round turns over all, and tied with a reef knot.

WIRE RIGGING

Wire is now extensively used for the standing rigging of all classes of vessels.

The great advantage wire has over hemp for shrouds, back-stays, etc., is, it presents less surface to the wind, wire-rope of one-third the thickness of hemp being nearly if not quite as strong; it looks much lighter, and gives a craft a neat look about her upper works, besides being more lasting. Iron wire should be galvanized, or it will soon perish. Copper wire may have a coat of paint over it, as that keeps the verdigris from eating into the strands, thereby weakening the rope. Copper wire is very little used, except in small yachts.

When selecting the ordinary wire rigging, it is always best to break off a piece at either end of the coil; if the strands, or rather yarns, present a sparkling crystal appearance, it shows that there is a want of fibre in the iron, and therefore should not be trusted when a great strain is required. If, on the contrary, the broken part is a dull grey color, with a stringy look, it is all right, and, if properly galvanized, will last a long time. It must not be forgotten that galvanizing reduces the strength of iron some 20 per cent., so that must be taken into account when calculating the strain it will have to bear.

The operation of splicing wire-rope is so varied, that it would take up too much space to describe all the different ways of doing so. Scarcely two seamen will be found to splice it alike. The easiest way, consistent with strength, is as follows: Open out the strands as for a long splice, and lay them up in the same way. Instead, however, of knotting the strands together with an overhand knot, separate each opposite strand into two parts and cross each part, tucking the ends under and over the laid up strands until the ends are expended. Worm, parcel, and serve over, and the splice will last as long as the rope itself.

A three-quarter inch wire-rope is about equal to 2 inch hemp rope in strength.

One inch wire equals $2\frac{3}{4}$ inch hemp.

Two inch wire equals 5 inch hemp.

Two-and-a-half inch wire equals $6\frac{1}{2}$ inch hemp rope; and so on in the same proportion.

☞ See page 57 for weight and strength of Manila Rope.

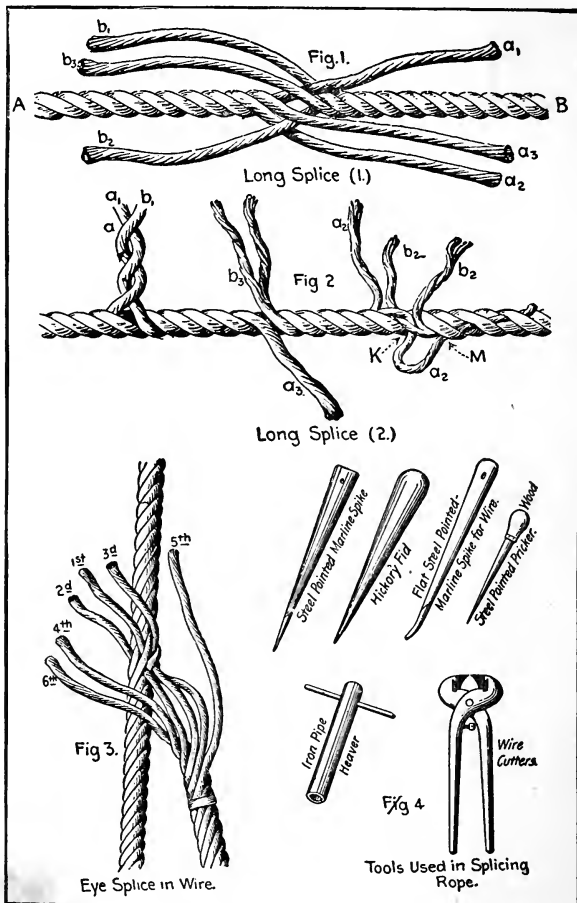

Wire Rope. Plate 1.

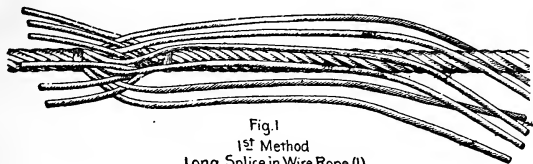

Fig. 1
1st Method
Long Splice in Wire Rope. (1)



Fig. 2
1st Method
Long Splice in Wire Rope. (2)

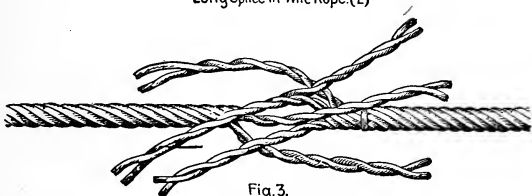

Fig. 3.
2^d Method.
Long Splice in Wire.

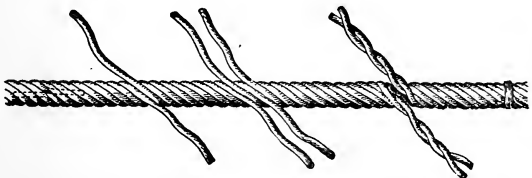

Fig. 4.
2^d Method.
Long Splice in Wire.

WORKING IN WIRE ROPE

Wire rope is usually six-stranded wound over a hemp heart.

In splicing, we may work with the strands separately or in pairs. The work calls for special appliances and for a degree of skill such as can be acquired only by long practice under expert instruction. Something may be learned from careful description, and much more from an occasional visit to a rigging loft; but the facilities which are available on ship-board do not permit of doing such work as is possible with a rigger's bench, a turning-in machine, etc. Where a heavy rope is to be bent around a thimble or the parts otherwise brought together for splicing or seizing, a rigger's-screw is needed. In the absence of this, a vise may be used, but less conveniently.

In tucking the strands of a splice, the lay of the rope is opened out and the spike left in, holding the strands apart, until the tuck has been made. For dragging the strands through, a jigger is used on each one, the body of the rope being held by another jigger or a lashing. After a tuck, the parts of the rope are hammered down tightly upon each other. Wire-cutters are used for cutting off ends.

Fig. 4, Plate 1, shows the tools used in working in wire on shipboard.

Plate 1, An Eye-Splice in Wire, Fig. 3.—Get the rope on a stretch, allow from 18 to 24 inches from the end for splicing, and put on a mark with a couple of turns of twine. Measure along the rope from this mark the length of the eye (once and one-half the round of the thimble) and put on another similar mark. Paint with red lead, worm, parcel, paint again, and double serve between the marks. Now come up the stretch and seize the thimble in, breaking the rope around by the rigger's-screw and putting on a good racking seizing around both parts. Come up the screw, unlay the end of the wire, and cut out the heart close to the service. Now, with the thimble toward you, counting from right to left 1, 2, 3, etc., stick No. 4 strand from right to left under the upper strands of the rope just clear of the service, opening the strands by a spike. Haul through by hand. In the same manner—under two and over one strand—tuck the remaining strands, in the following order: 3, 5, 2, 6, 1. Now, commencing with any strand, tuck again whole and haul through by means of a jigger. Hammer the strands down in place, cut each strand down to one-half size and tuck again, hauling through with a jigger as before. Cut the strands down to one-quarter and tuck again. Hammer down all strands and cut off the wire with a wire-cutter.

Plate 2. A Long Splice in Wire. Figs. 1 and 2.—Put on a good seizing six to ten feet—according to the size of the rope—from the end of one of the ropes to be spliced, and a similar seizing one to two feet from the end of the other rope. Unlay, open out the strands, cut out the heart, and marry the ends together with strands interlacing. Cut the seizing on the short end. Unlay one of the short strands, following it up in the same lay with the opposite long strand, leaving end enough to tuck. Continue in the same manner with the remaining strands, except as to the distance to which they are laid up, this distance being varied in such a way as to leave the successive pairs an equal distance apart, as shown in Fig. 2. Commencing with any two strands, half knot them together (full size), then divide each into three parts, and tuck these parts separately as shown; or, cut out a few inches of the heart and insert the ends of the strands in its

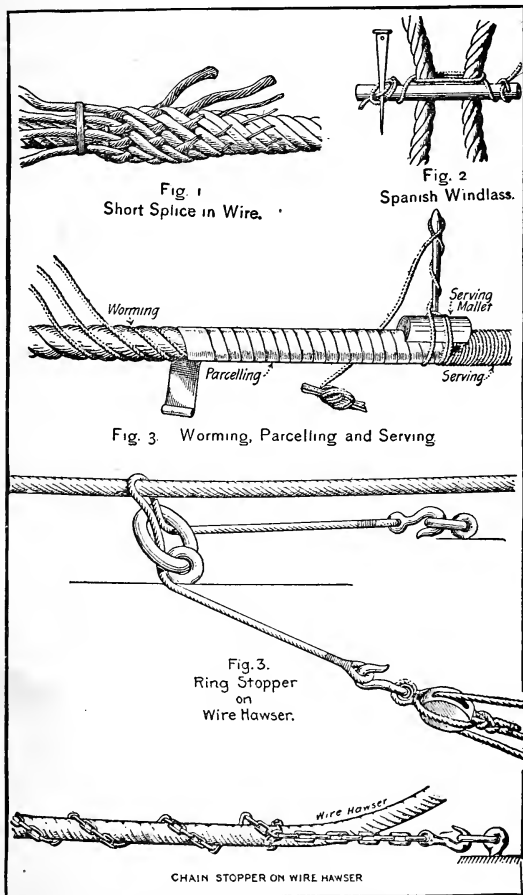

Wire Rope. Plate 3.

place in the centre of the rope. When a splice is to be served, the latter way of finishing it off answers very well, but not otherwise.

Note that this splice is made by working always to the right, the strands of A (long strands) being all worked into B.

A Long Splice in Wire, Figs. 3 and 4 (second methods).—Put on a good seizing an equal distance from the ends of the ropes to be spliced, from six to ten feet, according to the size of the rope. Unlay the strands in pairs, cut out the heart, marry together (Fig. 3), and lay up the strands in the same manner as in an ordinary three-stranded long splice in hemp, so that the strands meet an equal distance apart (Fig. 4). Then take any two ends (double strands), separate the strands, unlay one of these single strands, of A for example, and follow up in the lay with one of the corresponding single strands of B. The other single strand of A in the original pair, is left, with the corresponding single strand of B lying along side of it. This is repeated with each of the original double strands. There are now six sets of single strands of A and B lying together at different points of the rope, ready for tucking. The splice is finished off either by overhand knotting these ends, or by inserting the ends in place of the heart.

In view of the difficulty and delay involved in splicing wire rope, it is often convenient to make use of other methods for making an eye or for joining two ropes temporarily. Your attention is called to the use which may be made of the clamps shown in Plate 4. These are quickly and easily applied, and where several of them are used together, they may give nearly or quite as strong a connection as a splice.

Plate 3. A Short Splice in Wire, Fig. 1. Put on a good seizing two or three feet—according to the size of the rope—from the end of one of the ropes to be spliced, and a similar seizing one or two feet from the end of the other rope. Unlay the ends and open out the strands, cutting out the heart close to the seizings. Marry them together and clap on a temporary seizing around the short ends of the body of the rope, to hold the parts close together. Commencing with any one of the long strands, tuck each in succession over one and under two strands, opening out the lay with a spike. Tuck the remaining strands in the same manner; twice whole strands, once one-half, and once one-quarter, hauling through with a jigger each time. Then turn the splice around, cutting the temporary seizing on the short ends, and tuck the short strands once one-half and once one-quarter, heaving them through with a jigger. Hammer down all parts and trim off the ends.

A Spanish Windlass, Fig 2.—For heaving two parts of a rope together. With heavy ropes, the parts may be hove together by power of some kind, such as a Spanish Windlass, a rigger's screw, or a turning-in machine.

Worming, Parcelling, and Serving. (Plate 3.)—Rope which is to be exposed to the weather or to exceptionally hard usage is protected by worming, parcelling and serving.

Parcelling consists of wrapping the rope spirally with long strips of canvas, following the lay of the rope, and overlapping like the shingles on a roof to shed moisture.

Serving consists in wrapping small-stuff snugly over the parcelling, each turn being hove taut as possible so that the whole forms a stiff protecting cover for the rope. A "serving mallet" is used for passing the turns, each turn being hove taut by the leverage of the handle as illustrated in Plate 3.

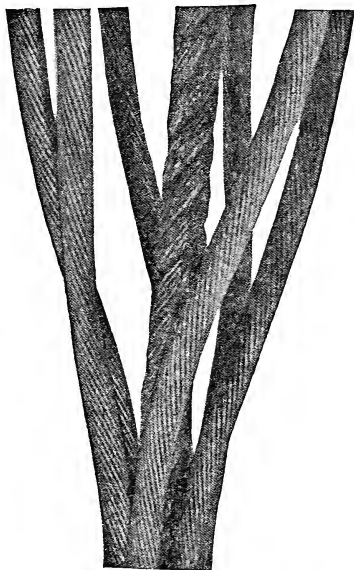

Wire Rope, Showing Hemp Core
Six stranded around a hemp heart.



Making an eye or a temporary splice by use of clamps
These clips were tested and broke under a strain of 54,000 lbs.

PARTS OF A BLOCK.

This diagram shows the various parts which, placed in proper position make it possible with other similar appliances and the use of attached ropes to handle heavy weights, raising and lowering the same, with the smallest amount of effort. The parts are the pin or axle (a), on which the sheave turns, the sheave or wheel (b) over which the rope passes and the shell (d) or outside of block. The strap, which is not shown, is made of rope or iron passed around the shell, sinking into the grooves shown and when used as a single block is fitted with a hook at the end of the strap.

The sheave may be of metal or of a very hard wood called Lignum-Vitae. If of wood it is bouched (c), which is fitting with metal inserts through which the pin passes. In patent blocks the bouching is fitted with roller bearings as at E.

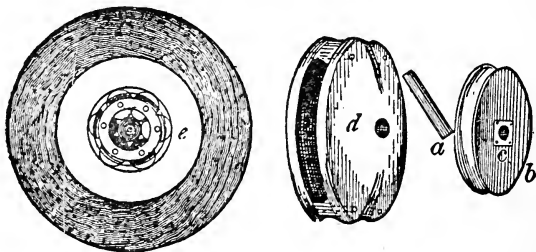

Blocks and ropes when assembled together ready for use are called Tackles and examination of the diagram will show many of the methods used to increase the lifting power and lessen the manpower or exertion required in lifting or hauling.

It is well to remember that adding blocks slows up the operation of the tackle and also causes the accumulation of rope (or fall) and may easily be carried too far. In other words, get enough power but not too much.

The amount of lifting power of a tackle is called its Purchase and with a single whip or block above (Fig. 44) you must pull with a strain equal to the weight of the object (W) to be raised. With a block at (W) as in (Fig. 45) and the block above as in (Fig. 44) or rigged as shown in (Fig. 46) only one-half the pull is required. Rigged as shown in Fig. 47 and with the rope returned through the upper block as shown in Fig. 48 only one-third the power is necessary and so on following the different tackles shown, the letter and figure under each weight giving the degree by which the lifting power is multiplied.

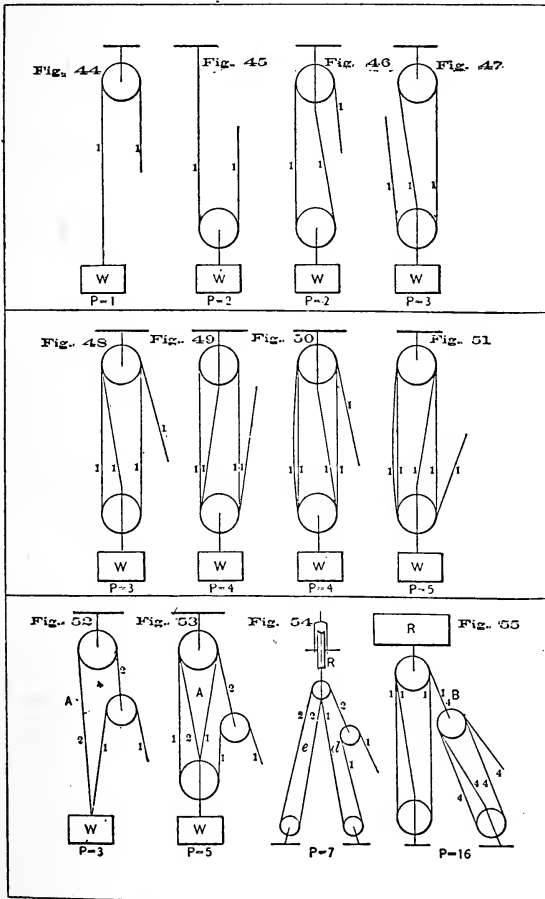

Purchase by Block and Tackle. Plate 1.

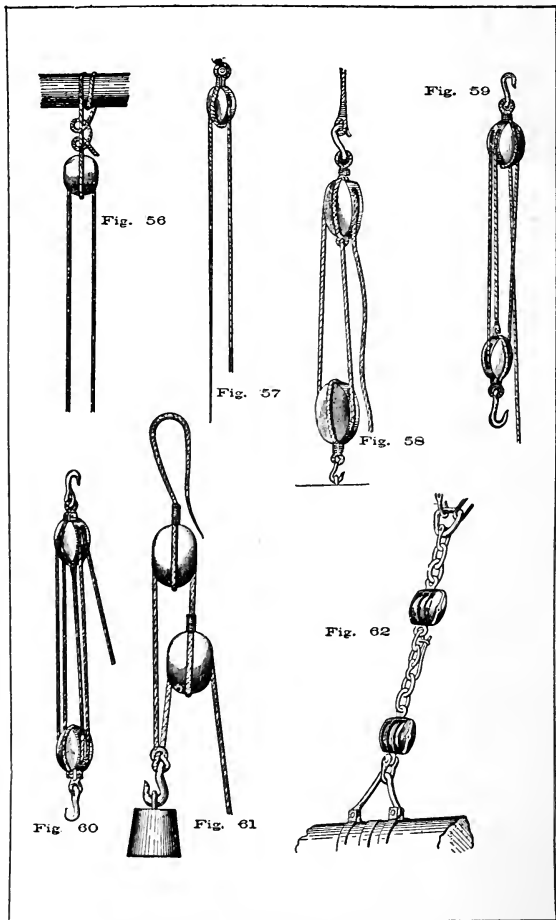

Names of Tackles shown. (See page 55).

- Fig. 44—Single whip.
 Fig. 45—Same, with Lower Block.
 Fig. 46—Gun Tackle Purchase.
 Fig. 47—Inverted Gun Tackle.
 Fig. 48—A Luff Tackle.
 Fig. 49—Inverted Luff Tackle.
 Fig. 50—Double Purchase.
 Fig. 51—Inverted Double Purchase.
 Fig. 52—Single Spanish Burton.
 Fig. 53—Double Spanish Burton.
 Fig. 54—"Bell's" Purchase.
 Fig. 55—Luff upon Luff.

The (W) suspended is in each case the weight to be raised. Figs. 54-55 are made fast below and the purchase is downward as for booms or yards.

Rules to determine power required.

Rule 1. Divide the weight of the object to be raised by the number of parts of rope at the movable block or blocks and the quotient represents the amount of power required.

(It must be remembered that a fixed or stationary block adds nothing to the lifting power of a tackle, the only help coming from the movable blocks and a liberal allowance, about one-fifth, must be made for friction.)

Rule 2. The amount of purchase required to raise a given weight with a given power is found by dividing the weight by the power and the quotient shows the number of parts of rope to be attached to the lower block.

Rule 3. The weight that a rope will bear or is "good for" multiplied by the number of parts of rope at the movable blocks, gives the "power" of the tackle or the weight it will raise.

Rule 4. Always rig with the block carrying the larger number of parts of rope as the movable block and nearest to the object to be raised.

Rule 5. It is well occasionally to shift ends of the pin in the block as it wears unequally and the sheave sometimes binds in the shell.

STRENGTH OF ROPE (Manila).

Circumference (inches)	$\frac{1}{2}$	$\frac{3}{4}$	1	$1\frac{1}{8}$	$1\frac{1}{4}$	$1\frac{1}{2}$	$1\frac{3}{4}$	2	$2\frac{1}{4}$	$2\frac{1}{2}$	$2\frac{3}{4}$	3
Diameter of Rope (inches)	$\frac{3}{16}$	$\frac{1}{4}$	$\frac{5}{16}$	$\frac{7}{16}$	$\frac{1}{2}$	$\frac{9}{16}$	$\frac{5}{8}$	$\frac{3}{4}$	$\frac{13}{16}$	$\frac{7}{8}$	$\frac{15}{16}$	1
Breaking Stress (pounds)	405	585	700	900	1170	1800	2295	3200	3750	4050	6050	7200
Weight (lbs. per foot)	.035	.045	.055	.065	.075	.085	.110	.140	.170	.200	.240	.275

This computation is for new rope and, to have a safe working load, not more than one-third of this weight should be suspended. Rope perishes rapidly and if exposed to the weather or stored where dampness or mildew can reach it, soon becomes unreliable.

Tackles as shown.

- Fig. 56—A Single Whip.
 Fig. 57—A Runner.
 Fig. 58—Gun Tackle Purchase.
 Fig. 59—A Luff Tackle.
 Fig. 60—A Twofold Purchase.
 Fig. 61—Single Spanish Burton.
 Fig. 62—Jeers (with treble purchase).

A block with one sheave is termed single-fold, with two sheaves double-fold, with three sheaves treble-fold, etc.

THE CAT RIG

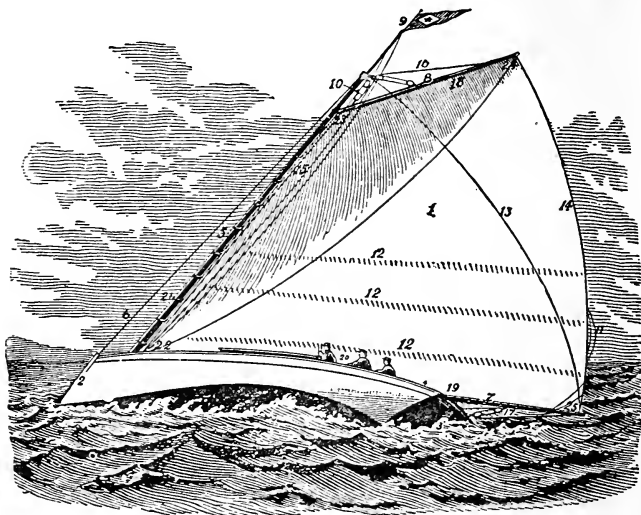

NAMES OF SPARS, SAILS, RIGGING, ETC.

1 Mainsail	10 Throat Halyards	19 Foot of Sail
2 Stem	11 Reef Cringles	20 Cockpit
3 Rudder	12 Reef Points	21 Mast Hoops
4 Tiller	13 Topping Lift	22 Tack of Sail
5 Mainmast	14 Leach of Sail	23 Throat of Sail
6 Forestay	15 Luff of Sail	24 Peak of Sail
7 Main Boom	16 Peak Halyards	25 Clew of Sail
8 Main Gaff	17 Main Sheet	
9 Truck	18 Head of Sail	

SLOOP RIG

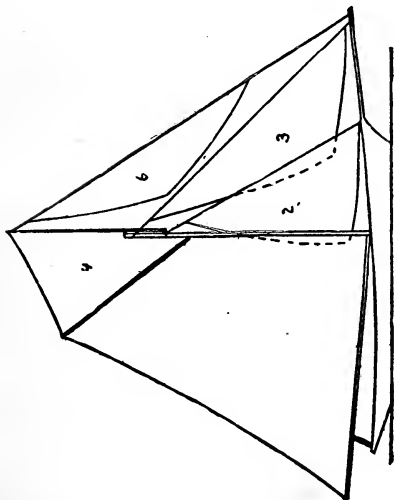

- 1 Mainsail
- 2 Fore Staysail
- 3 Jib
- 4 Working Gaff Topsail

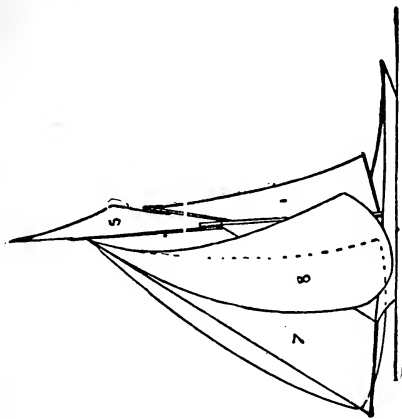

- 5 Club Topsail
- 6 Jib Topsail
- 7 Balloon Jib Topsail
- 8 Spinnaker

THE CUTTER RIG

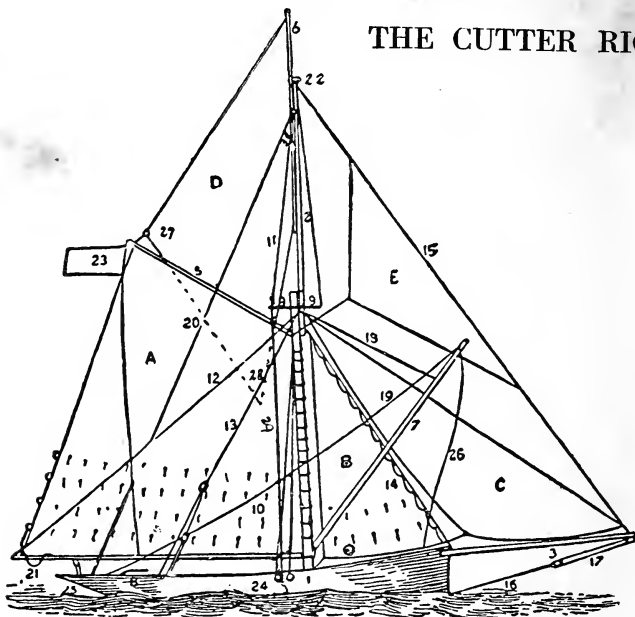

NAMES OF SPARS, SAILS, RIGGING, ETC.

SPARS

- | | | | |
|-------------|-------------|-----------------|------------------|
| 1 Lowermast | 3 Bowsprit | 5 Gaff | 7 Spinnaker Boom |
| 2 Topmast | 4 Main Boom | 6 Topsail Sprit | 8 Tiller |

RIGGING AND ROPES

- | | | |
|--------------------|---------------------|---------------------------|
| 9 Crosstrees | 16 Bobstay | 23 Ensign |
| 10 Shrouds | 17 Bobstay Fall | 24 Channels |
| 11 Topmast Shrouds | 18 Spinnaker Boom | 25 Mainsheet |
| 12 Topping Lift | Topping Lift | 26 Spinnaker Boom Guy |
| 13 Masthead Runner | 19 Spinnaker Boom | 27 Clew of Sprit Topsail |
| and Tackle | Brace | 28 Tack of Sprit Topsail |
| 14 Forestay | 20 Topmast Backstay | 29 Tack Line of Pendant |
| 15 Topmast Stay | 21 Reef Pennant | 30 Sprit Topsail Halyards |
| | 22 Truck | |

SAILS

- | | | | | |
|------------|------------|-------|-----------------|---------------|
| A Mainsail | B Foresail | C Jib | D Sprit Topsail | E Jib Topsail |
|------------|------------|-------|-----------------|---------------|

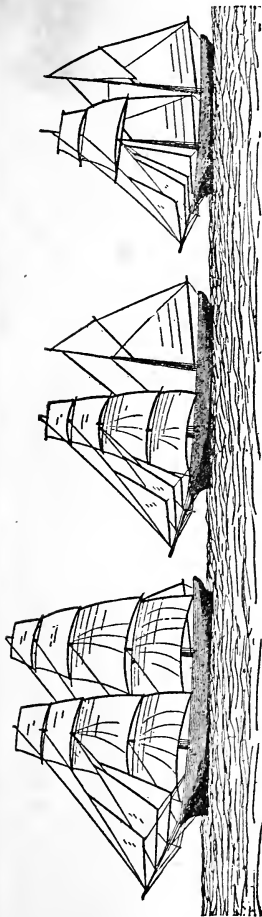

Fig. 1

THE BRIG has two masts and is rigged with square sails on both masts (Fig. 1).

THE BRIGANTINE is similar to the Brig, except that the lower sail or main sail on the main mast, is not a square-sail.

THE HERMAPHRODITE BRIG is square-rigged on the foremast but not on the mainmast (Fig. 2).

THE TOPSAIL SCHOONER has square-sails on the foremast above the foresail (Fig. 3).

(In order to make the upper sails of merchant vessels easier to handle with the small crew on board, it is the general practice to divide the topsails into two sections with separate yards. The sections are called Lower Topsails and Upper Topsails.)

Standing Rigging is the rigging used for the support of the masts, yards and jib-boom.

Running Rigging is the rigging used to control the yards and sails or to change their direction.

THE SCHOONER RIG

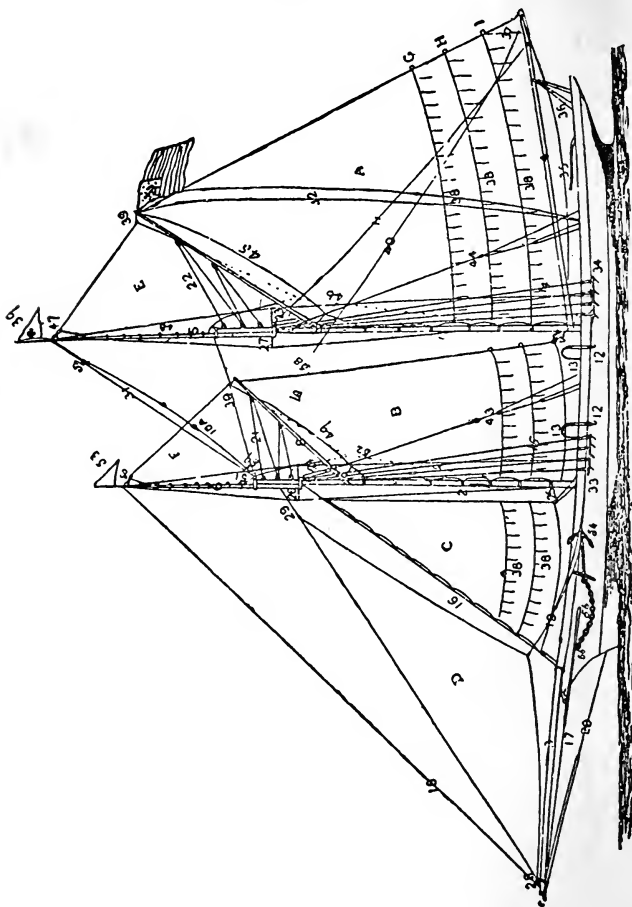

TWO MAST SCHOONER

NAMES OF SPARS, SAILS, RUNNING AND STANDING RIGGING, ETC.

SPARS, ROPES, ETC.

- | | | | |
|-----|-------------------------------|----|---|
| 1 | Mainmast | 42 | Fore Sheets |
| 2 | Foremast | 43 | Fore Masthead Runner and Tackle |
| 3 | Bowsprit | 44 | Main Masthead Runner and Tackle |
| 4 | Main Boom | 45 | Main Gaff-Topsail Sheet |
| 5 | Maintopmast | 46 | Main Gaff-Topsail Tack Line |
| 6 | Foretopmast | 47 | Main Gaff-Topsail Halyards |
| 7 | Main Gaff | 48 | Main Gaff-Topsail Mast Hoops |
| 8 | Fore Gaff | 49 | Fore Gaff-Topsail Sheet |
| 9 | Leach of Maintopmast Staysail | 50 | Fore Gaff-Topsail Halyards |
| 10 | Foot of Maintopmast Staysail | 51 | Fore Gaff-Topsail Mast Hoops |
| 10a | Luff of Maintopmast Staysail | 52 | Fore Gaff-Topsail Tack Line |
| 11 | Main Topping Lift | 53 | Club Signal |
| 12 | Davit Falls | 54 | Anebor (fished) |
| 13 | Davits | 55 | Hawse-Hole |
| 14 | Main Shrouds | 56 | Cable |
| 15 | Fore Shrouds | 57 | Maintopmast Staysail Halyards |
| 16 | Forestay | 58 | Maintopmast Staysail Clew |
| 17 | Bowsprit Shrouds | 59 | Junction of Maintopmast Staysail Head and Foot (the Tack) |
| 18 | Foretopmast Stay | | |
| 19 | Jib Sheet | | |
| 20 | Bobstay | | |
| | A Mainsail | | G H I Reef Cringles |
| | B Foresail | | J Maintopmast Staysail |
| | C Fore Staysail | | |

SAILS, ETC.

- D Jib
E Main Gaff-Topsail (American)
F Fore Gaff-Topsail (American)

Bark—Sails.

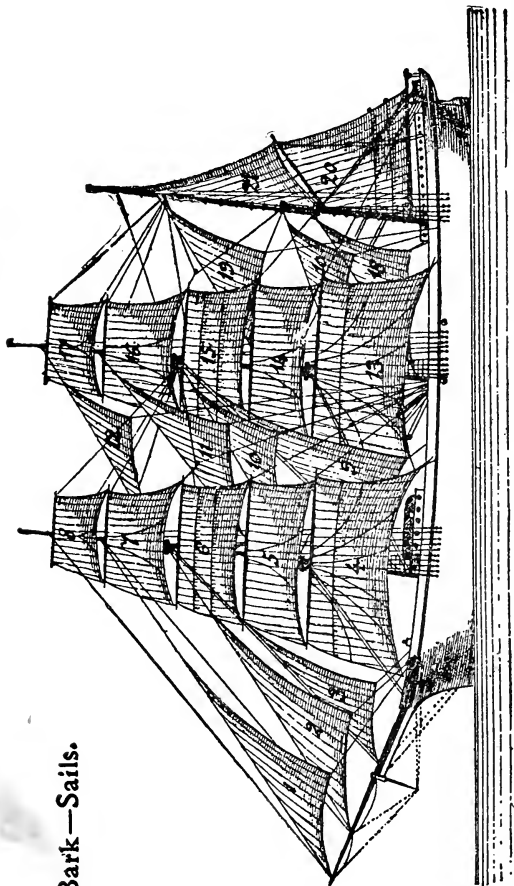

- | | | | | | | | |
|---|-----------------------|----|--------------------------|----|----------------------|----|-------------------------|
| 1 | Flying Jib | 7 | Fore Topgallant Sail | 13 | Main Sail | 19 | Mizzen Topmast Staysail |
| 2 | Jib | 8 | Fore Royal | 14 | Main Lower Topsail | 20 | Spanker |
| 3 | Fore Topmast Staysail | 9 | Main Topmast Staysail | 15 | Main Upper Topsail | 21 | Gaff Topsail |
| 4 | Fore Sail | 10 | Middle Staysail | 16 | Main Topgallant Sail | | |
| 5 | Fore Lower Topsail | 11 | Main Topgallant Staysail | 17 | Main Royal | | |
| 6 | Fore Upper Topsail | 12 | Main Royal Staysail | 18 | Mizzen Staysail | | |

BARKE NTINE is rigged same as Bark except that it is square-rigged only on foremast.

Bark—Masts and Spars.

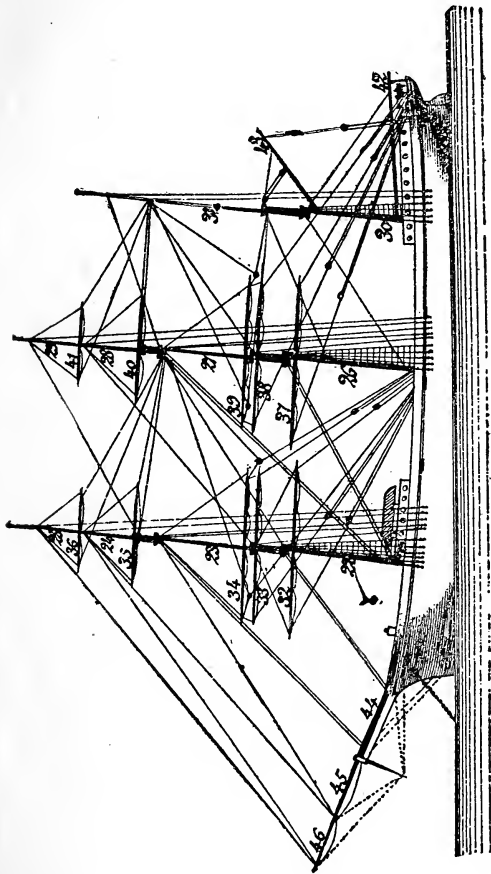

- | | | | | | | | |
|----|----------------------|----|-------------------------|----|-------------------------|----|-----------------|
| 22 | Fore Mast | 29 | Main Royal Mast | 36 | Fore Royal Yard | 43 | Spanker Gaff |
| 23 | Fore Topmast | 30 | Mizzen Mast | 37 | Main Yard | 44 | Bowspit |
| 24 | Fore Topgallant Mast | 31 | Mizzen Topmast | 38 | Main Lower Topsail Yard | 45 | Jib-boom |
| 25 | Fore Royal Mast | 32 | Fore Yard | 39 | Main Upper Topsail Yard | 46 | Flying Jib-boom |
| 26 | Main Mast | 33 | Fore Lower Topsail Yard | 40 | Main Topgallant Yard | | |
| 27 | Main Topmast | 34 | Fore Upper Topsail Yard | 41 | Main Royal Yard | | |
| 28 | Main Topgallant Mast | 35 | Fore Topgallant Yard | 42 | Spanker Boom | | |

FOUR MAST BARK

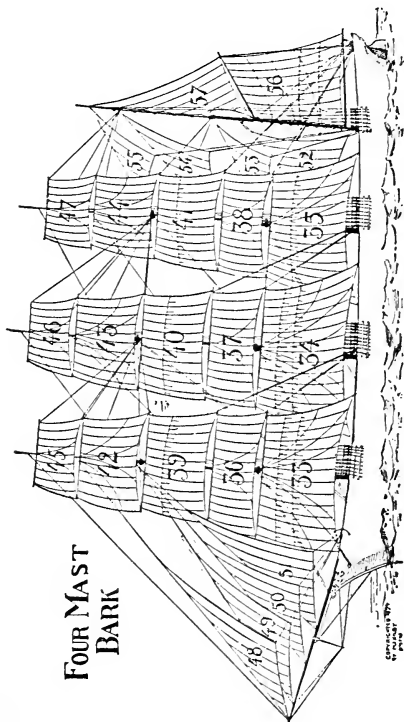

Masts, Commencing forward

Foremast Mainmast Mizzen Mast Jigger Mast

— SAILS —

- | | | | |
|-----------------------|-------------------------|---------------------------|-------------------------------|
| 33 Foresail | 38 Mizzen Lower Topsail | 43 Main Topgallant Sail | 48 Flying Jib |
| 34 Mainsail | 39 Fore Upper Topsail | 44 Mizzen Topgallant Sail | 49 Outer Jib |
| 35 Cross Jack | 40 Main Upper Topsail | 45 Fore Royal | 50 Inner Jib |
| 36 Fore Lower Topsail | 41 Mizzen Upper Topsail | 46 Main Royal | 51 Fore Topmast Staysail |
| 37 Main Lower Topsail | 42 Fore Topgallant Sail | 47 Mizzen Royal | 52 Jigger Staysail |
| | | | 53 Jigger Middle Staysail |
| | | | 54 Jigger Topmast Staysail |
| | | | 55 Jigger Topgallant Staysail |
| | | | 56 Jigger |
| | | | 57 Gaff Topsail |

FIVE MAST BARK

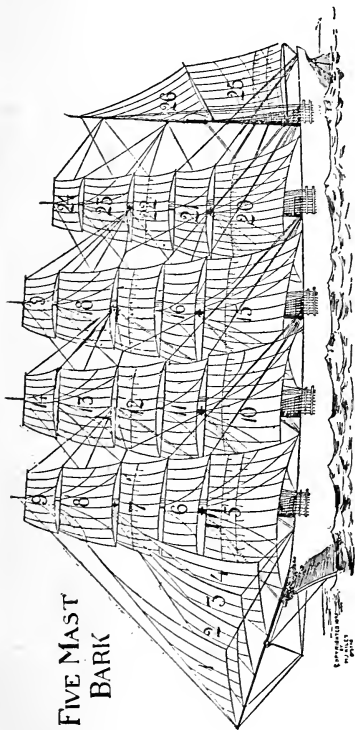

Masts, commencing forward

Foremast Mainmast Middlemast Mizzen Mast Jigger Mast

- 1 Flying Jib
- 2 Outer Jib
- 3 Inner Jib
- 4 Fore Topmast Staysail
- 5 Foresail
- 6 Fore Lower Topsail
- 7 Fore Upper Topsail

- SAILS**
- 8 Fore Topgallant Sail
 - 9 Fore Royal
 - 10 Mainsail
 - 11 Main Lower Topsail
 - 12 Main Upper Topsail
 - 13 Main Topgallant Sail

- 14 Main Royal
- 15 Middle Sail
- 16 Middle Lower Topsail
- 17 Middle Upper Topsail
- 18 Middle Topgallant Sail
- 19 Middle Royal

- 20 Cross Jack
- 21 Mizzen Lower Topsail
- 22 Mizzen Upper Topsail
- 23 Mizzen Topgallant Sail
- 24 Mizzen Royal
- 25 Jigger
- 26 Gaff Topsail

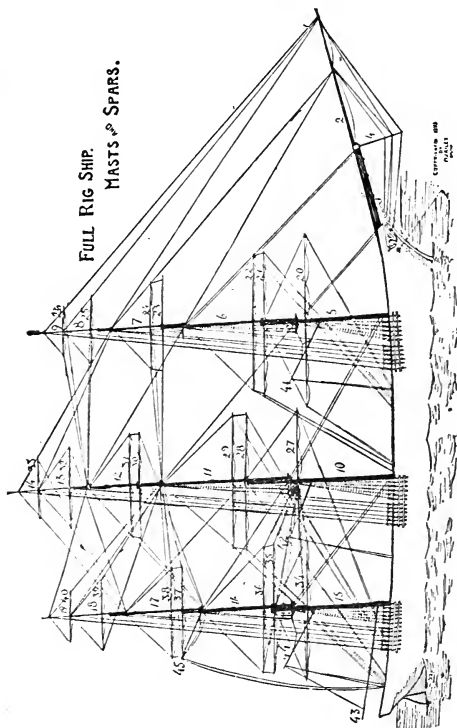

- | | | | |
|-------------------------|-------------------------------|---------------------------------|---------------------------------|
| 1 Flying Jib-boom | 13 Main Royal Mast | 25 Fore Royal Yard | 37 Mizzen Lower Topgallant Yard |
| 2 Jib-boom | 14 Main Skysail Mast | 26 Fore Skysail Yard | 38 Mizzen Upper Topgallant Yard |
| 3 Bowsprit | 15 Mizzen Mast | 27 Main Yard | 39 Mizzen Royal Yard |
| 4 Martingale Boom | 16 Mizzen Topmast | 28 Main Lower Topsail Yard | 40 Mizzen Skysail Yard |
| 5 Foremast | 17 Mizzen Topgallant Mast | 29 Main Upper Topsail Yard | 41 Fore Trysail Gaff |
| 6 Fore Topmast | 18 Mizzen Royal Mast | 30 Main Lower Topgallant Yard | 42 Main Trysail Gaff |
| 7 Fore Topgallant Mast | 19 Mizzen Skysail Mast | 31 Main Upper Topgallant Yard | 43 Spanker Boom |
| 8 Fore Royal Mast | 20 Fore Yard | 32 Main Royal Yard | 44 Spanker Gaff |
| 9 Fore Skysail Mast | 21 Fore Lower Topsail Yard | 33 Main Skysail Yard | 45 Monkey Gaff |
| 10 Mainmast | 22 Fore Upper Topsail Yard | 34 Cross Jack Yard | |
| 11 Main Topmast | 23 Fore Lower Topgallant Yard | 35 Mizzen Lower Topgallant Yard | |
| 12 Main Topgallant Mast | 24 Fore Upper Topgallant Yard | 36 Mizzen Upper Topgallant Yard | |

**FULL RIG SHIP.
STANDING RIGGING.**

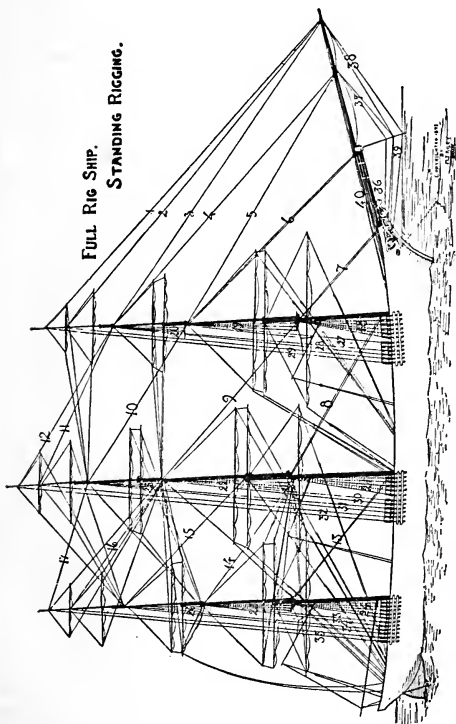

- 1 Fore Skysail Stay
- 2 Fore Royal Stay
- 3 Flying Jib Stay
- 4 Fore Topgallant Stay
- 5 Jib Stay
- 6 Fore Topmast Stay
- 7 Fore Stay
- 8 Main Stay
- 9 Main Topmast Stay
- 10 Main Topgallant Stay

- 11 Main Royal Stay
- 12 Main Skysail Stay
- 13 Mizzen Stay
- 14 Mizzen Topmast Stay
- 15 Mizzen Topgallant Stay
- 16 Mizzen Royal Stay
- 17 Mizzen Skysail Stay
- 18 Fore Rigging
- 19 Fore Topmast Rigging
- 20 Fore Topgallant Rigging

- 21 Main Rigging
- 22 Main Topmast Rigging
- 23 Main Topgallant Rigging
- 24 Mizzen Rigging
- 25 Mizzen Topmast Rigging
- 26 Mizzen Topgallant Rigging
- 27 Fore Topmast Backstays
- 28 Fore Topgallant Backstays
- 29 Fore Royal and Skysail Backstays
- 30 Main Topmast Backstay

- 31 Main Topgallant Backstay
- 32 Main Royal and Skysail Backstays
- 33 Mizzen Topmast Backstays
- 34 Mizzen Topgallant Backstays
- 35 Mizzen Royal and Skysail Backstays
- 36 Bobstays
- 37 Jib-boom Martingale Stay
- 38 Flying Jib-boom Martingale Stay
- 39 Martingale Guys or Back Ropes
- 40 Jib and Flying Jib-boom Guys

FULL RIG SHIP RUNNING RIGGING.

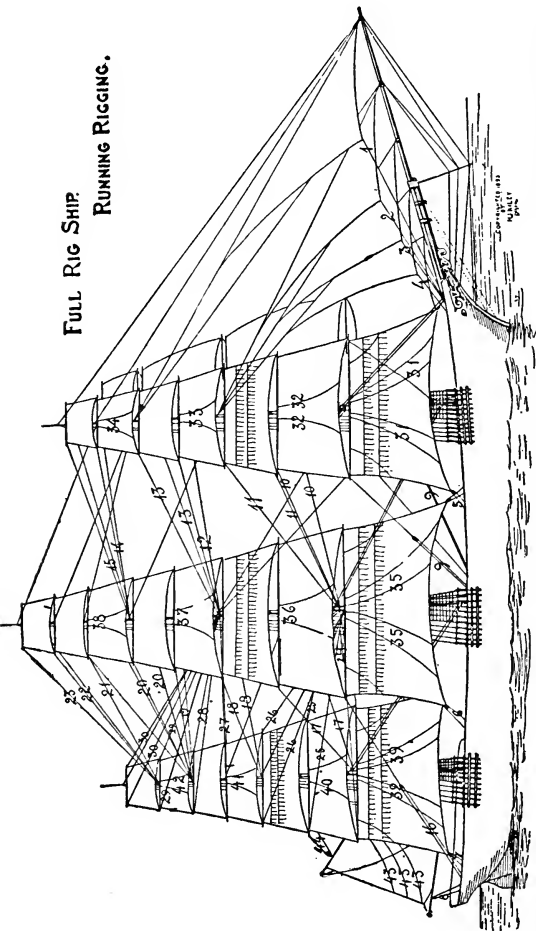

- | | | | |
|-------------------------------|--------------------------------|----------------------------------|--------------------------------|
| 1 Flying Jib Sheet | 12 Fore Lower Topgallant Brace | 23 Moonsail Brace | 34 Fore Royal Buntlines |
| 2 Jib Sheet | 13 Fore Upper Topgallant Brace | 24 Cross-Jack Brace | 35 Main Buntlines |
| 3 Middle Jib Sheet | 14 Fore Royal Brace | 25 Mizzen Lower Top sail Brace | 36 Main Topgallant Buntlines |
| 4 Fore Topmast Staysail Sheet | 15 Fore Skysail Brace | 26 Mizzen Upper Top sail Brace | 37 Main Topgallant Buntlines |
| 5 Fore Sheet | 16 Main Brace | 27 Mizzen Lower Topgallant Brace | 38 Main Royal Buntlines |
| 6 Main Sheet | 17 Main Lower Top sail Brace | 28 Mizzen Upper Topgallant Brace | 39 Cross-jack Buntlines |
| 7 Cross-jack Sheet | 18 Main Upper Top sail Brace | 29 Mizzen Royal Brace | 40 Mizzen Top sail Buntlines |
| 8 Sparker Sheet | 19 Main Lower Topgallant Brace | 30 Mizzen Skysail Brace | 41 Mizzen Topgallant Buntlines |
| 9 Fore Brace | 20 Main Upper Topgallant Brace | 31 Fore Buntlines | 42 Mizzen Royal Buntlines |
| 10 Fore Lower Top sail Brace | 21 Main Royal Brace | 32 Fore Top sail Buntlines | 43 Sparker Brails |
| 11 Fore Upper Top sail Brace | 22 Main Skysail Brace | 33 Fore Topgallant Buntlines | 44 Peak Halliard |

Full Rigged Ship—Sails.

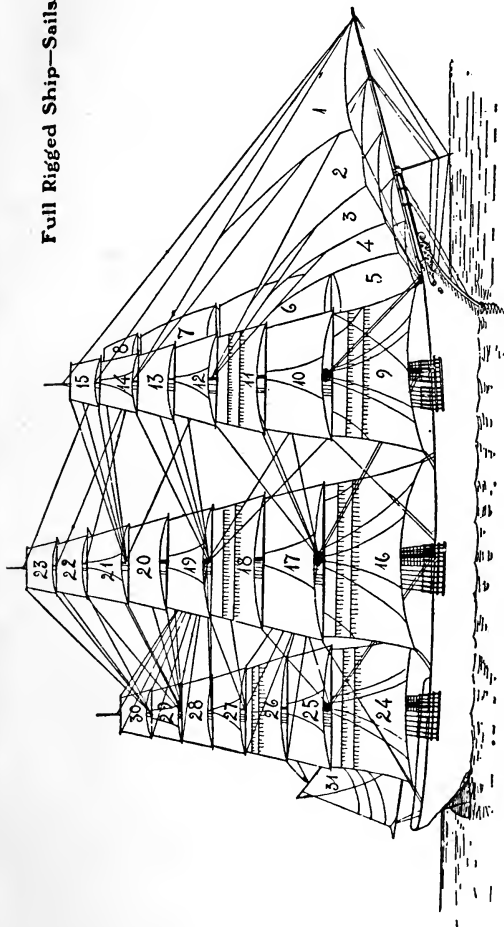

- 1 Flying Jib
- 2 Standing Jib or Outer Jib
- 3 Inner or Middle Jib
- 4 Fore Topmast Staysail
- 5 Lower Studdingsail
- 6 Topmast Studdingsail
- 7 Topgallant Studdingsail
- 8 Royal Studdingsail

- 9 Foresail or Forecourse
- 10 Fore Lower Topsail
- 11 Fore Upper Topsail
- 12 Fore Lower Topgallant Sail
- 13 Fore Upper Topgallant Sail
- 14 Fore Royal
- 15 Fore Skysail
- 16 Mainsail or Maincourse

- 17 Main Lower Topsail
- 18 Main Upper Topsail
- 19 Main Lower Topgallant Sail
- 20 Main Upper Topgallant Sail
- 21 Main Royal
- 22 Main Skysail
- 23 Moon-sail
- 24 Cross Jack

- 25 Mizzen Lower Topsail
- 26 Mizzen Upper Topsail
- 27 Mizzen Lower Topgallant Sail
- 28 Mizzen Upper Topgallant Sail
- 29 Mizzen Royal
- 30 Mizzen Skysail
- 31 Spunker

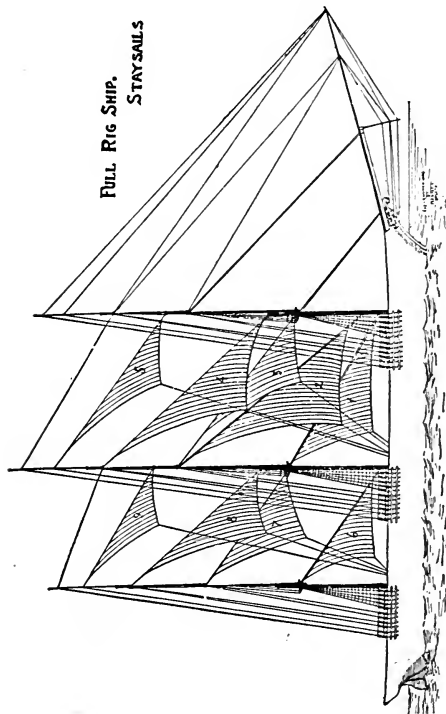

- | | | |
|-------------------------|----------------------------|------------------------------|
| 1 Main Staysail | 4 Main Topgallant Staysail | 7 Mizzen Topmast Staysail |
| 2 Main Topmast Staysail | 5 Main Royal Staysail | 8 Mizzen Topgallant Staysail |
| 3 Middle Staysail | 6 Mizzen Staysail | 9 Mizzen Royal Staysail |

FOUR MAST SHIP

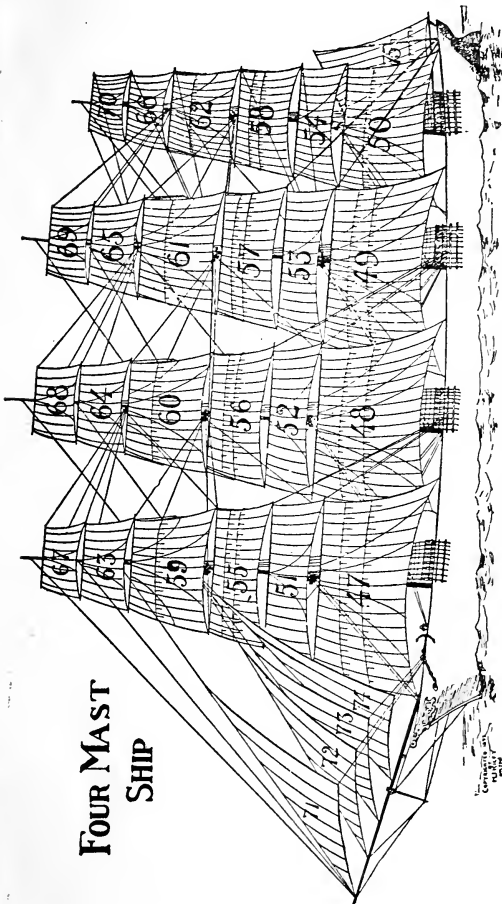

Masts, commencing forward

	Foremast	Mainmast	Mizzen Mast	Jigger Mast
	SAILS			
47	Mizzen Lower Topsail	59 Fore Topgallant Sail	65 Mizzen Royal	71 Flying Jib
48	Main Sail	60 Main Topgallant Sail	66 Jigger Royal	72 Outer Jib
49	Cross Jack	61 Mizzen Topgallant Sail	67 Fore Skysail	73 Inner Jib
50	Jigger	62 Jigger Topgallant Sail	68 Main Skysail	74 Fore Topmast Staysail
51	Fore Lower Topsail	63 Fore Royal	69 Mizzen Skysail	75 Spanker
52	Main Lower Topsail	64 Main Royal	70 Jigger Skysail	

NOTES ON WOODEN SHIP-BUILDING.

(The numbers in brackets refer to the nomenclature of the ship.)

The first thing to be considered in the building of a ship is the situation of the spot upon which it is proposed to carry on the work with reference to the difficulties which are to be overcome, first, in procuring the necessary material to be used in her construction, and, second, in launching her when finished and ready to be rigged. The most suitable location for a ship-yard with reference to the second part of this problem is by the side of a river or inland bay where there is deep water close to shore and a considerable rise and fall of the tide. The character of the ground should be such as to furnish a foundation sufficiently firm to sustain the whole weight of the new ship, so that no settling will take place during the progress of the work. In the case of heavy vessels it is generally found necessary to drive piles into the ground for the support of the ground-ways upon which the ship rests while building.

Before the work of actual construction begins the designer prepares a model made to a scale of from $\frac{1}{8}$ to $\frac{1}{4}$ inch to a foot, and shaped exactly like the new ship is to be when built. The model is usually made of several layers of different colored woods firmly joined together longitudinally for the purpose of facilitating the work of "taking off the lines" in the preparation of the plans. Measurements are now very accurately taken of the model, enlarged according to the scale used, and transferred to the floor of a large room called the "mold-loft," where they appear as sheer, half-breadth, and body plans. By means of these plans light wooden patterns called molds are made, which are the exact shape of every timber to be used in the construction of the ship. These molds being light and portable are often sent to considerable distances from the ship-yard, and are used by the workmen and shipwrights in getting out the timbers. This work is done by placing the molds and bevels upon each separate piece of rough timber and cutting or "lining" it to the shape of the mold.

When the preparatory work of getting out the timbers is finished, the foundation upon which the vessel is to rest while building is laid on the spot selected for this purpose. First to go down are the ground-ways, which consist of heavy pieces of timber resting on the ground, or on the piles which have been driven into the ground, and extending the entire length of the ship, and as far into the water as may be necessary to furnish a track or bed-way for the support of the launching-ways. On top of the ground-ways piles of blocks are laid about 5 feet apart, the uppermost blocks being wedge-shaped and made of some soft straight-grained wood. The height of the blocks depends upon the character of the work which is to be done on the bottom of the ship and on various conditions which will govern her descent into the water. Generally speaking, the blocks are so laid that when the keel is in place it will form an angle with the horizon of from $\frac{1}{2}$ to 1 inch to the foot. The amount of inclination depends upon the size of the ship—a large vessel not requiring as much inclination as a smaller one to give her the required movement toward the water when the time of launching arrives.

The first timber laid down is the keel [1], and great care must be taken when it is in place that it bears equally on all the blocks. The reason for this will be obvious when its importance, as the "backbone" or main strengthening piece of the entire frame, is

considered. In many cases the stem [34] and stern-post [40], which form the extremities of the keel, are scarfed and fastened to it before the keel is laid upon the blocks; but if not, they are the next timbers to be placed in position, and after they are secured, work is begun on the square-frame, which consists of all those ribs which are fastened to the keel. Beginning with the aftermost rib of the square-frame, they are raised from the ground by means of a derrick and set in position across the keel, to which they are securely bolted. The ribs of the square-frame are placed about 2 feet apart from centre to centre, and as each one is secured the keel is slipped down toward the water, until finally, when the last or forward rib is in place, the keel occupies the place on the blocks which it will retain until the vessel is launched. As the work progresses timber supports called shores are placed under the frame, and longitudinal strips of planking called ribbands are fastened to the ribs to bind them all together and keep them in shape. The keelson [12] is next laid parallel with the keel and directly over it and on top of the frames. It is secured to the keel by bolts, which pass through the keelson, the floor-timbers, and the keel.

Owing to the form of the ship, which gradually becomes sharper towards the stem and stern, the floor is lifted from a level line and the U-shaped ribs of the square-frame can no longer be used. The space between the after end of the square-frame and the stern-post and the forward end of the square-frame and the stem is called the cant-frame. The ribs in those spaces are called forward- and after-cants [84]. Instead of being joined together in a U-shaped form and laid across the keel, the heels of the cants abut upon the sides of a mass of timber called the forward and after dead-wood [36, 42] which is bolted to the keel, stern-post and stem. The cants are not placed perpendicularly to the keel, but incline more and more towards the extremities of the vessel as their distance from the square-frame increases. The position of their tops or heads is accurately marked on pieces of timber called harpins, which are made to conform to the proposed curve of the ship's side and extend from the tops of the forward and after ribs of the square-frame to the stem and stern-post respectively.

After the frame is all up it is set perfectly square with the middle line of the ship by means of a plummet let fall from the middle point of cross pieces of timber which join the tops of the frames at several points or stations to the middle line of the keel. Measurements are also frequently made to see that the breadth of beam as shown by the half-breadth plan is maintained before the final fastenings which secure the frame are put in. The clamps [18] or shelf-pieces are then secured in their places inside the frame timbers, and the frame is now ready for the planking [55-58] and ceiling [17]. Beginning at the keel, the outside planking is worked upward without a stop to the covering-board or planksheer [61], but the ceiling goes only as far as the marks on the ribs showing the position of the lower-deck beams [27], when they are worked to their places and the ceiling is continued to the next deck above, and so on until the upper deck is reached, if the vessel is to have more than two decks. At intervals spaces are left between the edges of the ceiling to admit air to the frame between the outer and inner planking; these spaces are called air-strakes [24].

The deck-frame, consisting of beams [25-27], ledges [29], and carlins [28], strengthened by knees, is next worked into place, and when it is finished the hatch-coamings [32], head-ledges, partners,

and thick strakes amidships are placed in position. The water-ways [19] are bolted to the deck beams and sides of the vessel, and the covering-board [61] is worked on top of the water-ways and fayed to the stanchions or tops of the frames. The decks [30] may now be laid, the rudder [45] hung, the bulwarks [63] built, and the main rail [62], catheads [67], etc. worked. To give additional strength to the structure, it is usual, in ships of considerable size, to lay one or two planks of the deck parallel with the water-ways, to which they are edge-bolted, in addition to being fastened to the beams. These planks are an inch thicker than the other deck planks and worked an inch into and over the beams. The rest of the deck planking is laid from amidships toward the water-ways on each side.

The vessel having now been decked and planked, the next work is to make her water-tight by calking the seams. This is done by driving a thread of oakum or cotton, as may be desired, in between the edges of the planks and at their ends or butts. The seams are then either painted or payed full of hot pitch, and the hull outside is carefully smoothed by going over it with planes. If the ship is not to be coppered, she is now painted, and, when dry, is ready to be launched.

Launching.

As has been explained, the weight of the ship while building is sustained by a central line of blocks resting on the ground-ways, and she is supported in an upright position by shores and spurs. When the time for launching arrives the weight of the fabric must be transferred from these blocks to inclined planes called launching-ways, which are fitted underneath the bottom of the vessel on each side of the keel, as follows: The ground-ways are first carefully smoothed and laid either to a gentle curve or to a straight line their entire length. The launching-ways may then be hauled up into place and fitted to the ground-ways. When this work has been accomplished a cradle composed of "packing," shores, poppets, and "chocks" is built upon the launching-ways to fit the bottom of the vessel. A small space is left between the packing and launching-ways for the insertion of long wedges, which are subsequently used in lifting the weight of the ship from the keel blocks. The different parts of the cradle are firmly bound together by "ribbands" and chains, which extend from one side of the framework underneath the keel to the other side and unite the whole into a rigid mass of timber. Just before launching, the cradle is shored up and the under sides of the launching-ways and the upper surface of the ground-ways are well greased with a mixture composed of tallow, oil, soap, and lamp-black; a stout piece of plank is also well greased and placed against the last pile of blocks in line with the keel, to form a track to receive the "fore-foot" when the ship leaves the ways. The sliding-ways being once more in place on top of the ground-ways the shores are removed from the cradle, and it is allowed to rest upon the wedges placed between it and the sliding ways. Finally the launching-ways are secured to the ground-ways by a stout plank fastened to both ways, and just before high water the word is given to "wedge up." Men armed with heavy sledges or battering rams are stationed at each of the wedges and simultaneously drive in the wedges until the weight of the ship is lifted from the keel blocks and rests upon the cradle, which in turn bears upon the

sliding-ways. The keel blocks are now removed one by one, beginning at the one nearest the water. The shores and spurs used in supporting the vessel while building are taken down, and now all that holds the ship is the plank which binds the ground-ways to the launching-ways. This is cut, and the ship, upheld by the cradle, gently glides down the inclined plane from the shore into her native element.

The cradle, being ballasted with pig-iron and weighted with chains and heavy timbers, sinks to the bottom, and the ship floats clear of it on the surface of the water. The anchors, having been cock-billed previous to the launch, are let go when it is desired to check the movement of the ship.

NOMENCLATURE OF THE SHIP.

(For explanation of numbers see diagram.)

1. **Keel.**—The principal timber in the frame of a ship. It is composed of several parts, the number varying with the length of the ship and store of timber, securely fastened together lengthwise by scarfs, and has grooves or rabbets cut in each of its sides to receive the edges of the garboard strakes.

2. **Shoe.**—A piece of timber of the same width, but siding less than the keel, bolted lightly to the bottom of the keel and designed to protect the keel in case of the grounding of the vessel. Short bolts are used to fasten it on, so that it may be torn off without injury to the keel in the event of the vessel's striking the bottom.

3. **Frames or Ribs.**—The separate parts of the skeleton of the ship, to which are fastened the planking, beams, etc. Each frame is composed of several parts, called **frame timbers**, bolted together to form a U-shaped structure, which rests at its middle point upon the keel, and is bolted to it. In each frame there are two **floor timbers**, called the **long** and the **short floor-head**, and they are so placed across the keel as to form alternate lines of abutment, or so that no joining line runs the entire length of the keel. Running along one side of the ship, for instance, one rib will end at the keel in a short floor-head, the opposite long one meeting it, while the next rib will end in a long one meeting the opposite short one. The remaining parts of the frame are called the 1st, 2d, 3d, 4th, and 5th futtocks, [5], [6], [7], [8], and [9], top-timber [10], and the top or stanchion [11], in the order given, counting from the floor timbers upward on each side of the keel to the main rail.

12. **Keelson.**—A piece of timber worked above the keel and floor timbers which it serves to bind to the keel. It sides the same as the keel and extends the length of the square frame and abuts on the deadwood.

13. **Scarf.**—A method of joining two ends of timbers longitudinally together by a dovetailing of their parts, which prevents them from being pulled apart lengthwise. The joint is secured vertically by scarf-bolts, which are driven through both parts of the scarf. The principal scarfs used in ship building are the butt-scarf for planking, and hook- and key-scarfs for heavier timber.

14. **Assistant (or sister) Keelson.**—A fore and aft piece of timber placed on top of the frames on either side of the main keelson, to which it is bolted.

15. Bilge Keelson.—To give additional strength to the frame, and in some ships to serve as a foundation for stanchions which support the lower-deck beams.

16. Bilge Strakes.—Thick strengthening planks which form the ceiling at the bilge.

17. Ceiling.—The inner planking of the ship.

18. Clamps (or shelf-pieces).—Heavy planks of the ceiling upon which the deck beams rest.

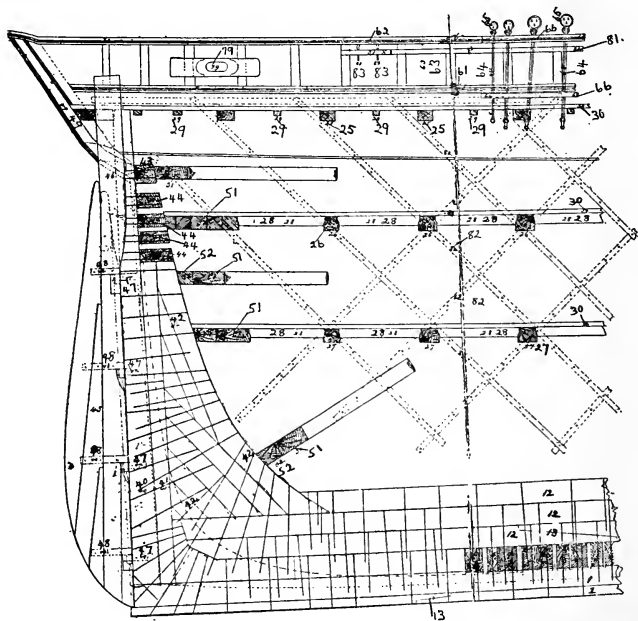

LONGITUDINAL SECTION — STERN

19. Main Water-ways.—Heavy pieces of timber worked in the angle made by the top of the deck beams and the inside of the frame timbers. It is strengthened on the lower decks of large ships by the addition of—

20. Upper Water-ways, and

21. Side Water-ways.

Knees.—A knee is a timber of natural growth with two arms nearly in shape of a right angle, and it is used to strengthen and

brace the different parts of a ship's frame, to resist the strain and pressure from every conceivable direction to which it is to be subjected. The knees are named from the position in which they are placed.

22. **Lodging Knee.**—One which is secured to the forward side of a beam and to the side of the vessel in a horizontal position.

Bosom Knee.—One which is similarly secured to the after side of a beam.

23. **Hanging Knee.**—A knee which is secured to the under side of a beam and vertically to the side of the ship. When from any cause, such as an intervening port or the peculiar shape of the ship's hull, it is not possible to secure the lower arm of a hanging knee vertically, and it is fastened diagonally to the ship's side, it is called a **dagger knee**. A **carlin knee** is used to fill the angle made by the intersection of a carlin with a beam or ledge. A **deck-hook** is a knee placed horizontally across the frames at the extremities of the ship as a support for the decks. The **stern-knee** is a large knee which fills the angle made by the intersection of the keel with the inner stern-post and forms a part of the after deadwood.

24. **Air-strakes.**—Spaces left between the edges of the ceiling planking to admit air to the frames between the inner and outer planking. Metallic ventilators, which are fitted to the covering board and so arranged that they may be screwed down tight in wet or stormy weather, serve the same purpose.

Beams.—Heavy transverse pieces of timber which form the principal part of the deck frames and serve to retain the sides of the ship in shape.

25. **Main-deck Beams.**

26. **Between-deck Beams.**

27. **Lower-deck Beams.**

28. **Carlins (or fore and afts).**—Short timbers placed fore and aft in the deck frame from one beam to another.

29. **Ledges.**—Short, transverse pieces of timber, smaller in size than the carlins, which form a part of the deck frame, and are let into the carlins and knees.

30. **Deck Planks.**—The covering of the deck frame.

31. **Hatches.**—Openings in the deck not less than two feet square. Smaller openings are called **scuttles**, and are usually not fitted with coamings.

32. **Hatch Coamings.**—Pieces of timber placed fore and aft to form a framing for the hatch. The pieces which are placed athwartships are called **head ledges**. The whole is dovetailed together and bolted to the deck frame.

33. **Hatch Covers.**—Wooden doors or covers for the hatches. The skylights or framing and sashlights which cover the hatches on the upper deck, and by which light is admitted to the decks below, are called **companions**.

34. **Stem.**—The forward termination or continuation of the keel. It is generally composed of two or more pieces of timber scarfed together. When in three parts, the separate pieces are called the upper, middle, and lower stem-piece, respectively. It is united to the keel by a hook-scarf.

35. **Gripe.**—A piece of timber bolted to the forward edge of the stem to form a finish and to protect the stem in the event of slight collisions.

Dead-wood.—Heavy pieces of timber, bolted to the inside of the keel, stem, and stern-post for increase of strength and as a solid foundation for the support of the cant frames.

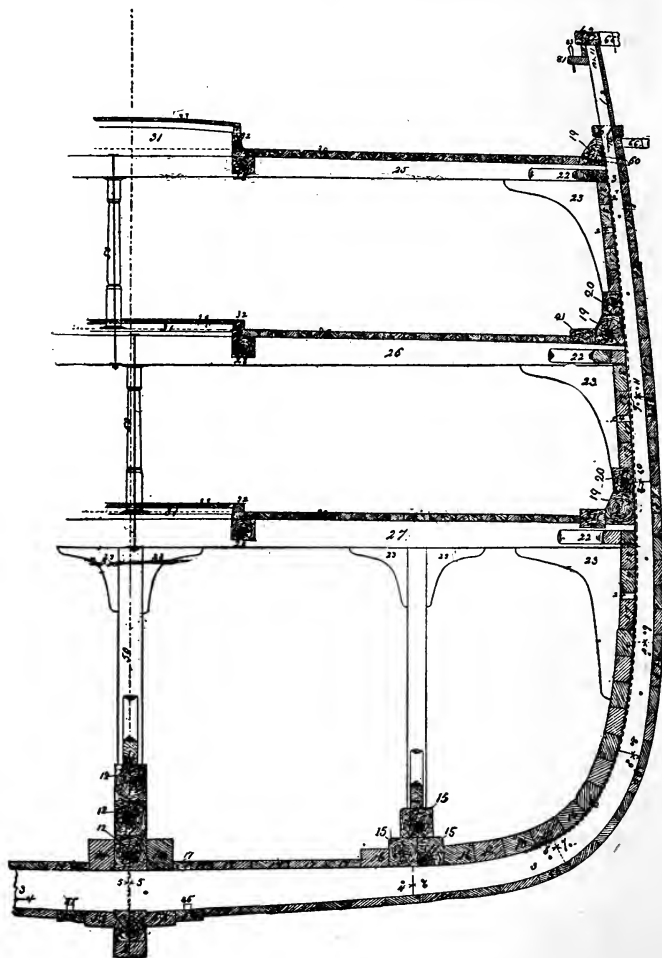

MIDSHIP CROSS SECTION

36. Forward Dead-wood.

37. Apron.—An inner strengthening timber bolted to the forward dead-wood and stem.

38. Knight-heads.—Vertical timbers bolted to the sides of the apron or forward dead-wood and extending upward on each side of the bowsprit, which they help support.

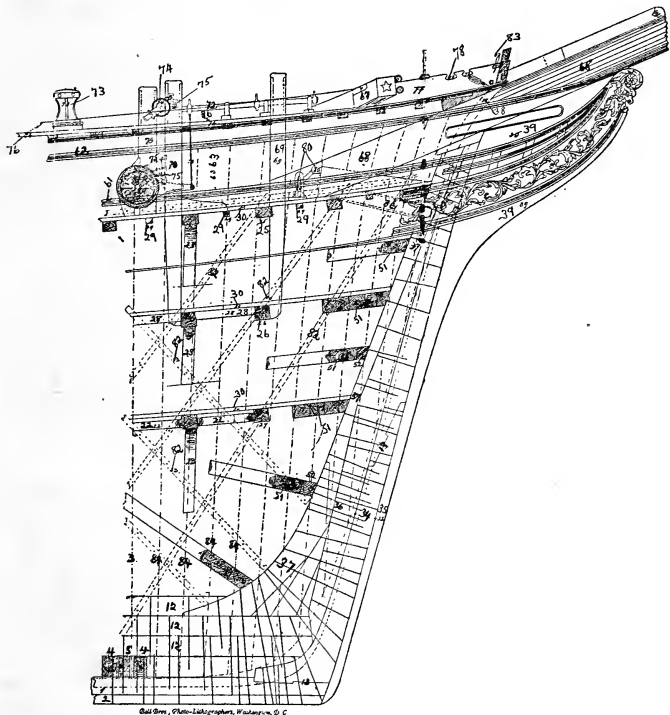

LONGITUDINAL SECTION — BOW

39. Figurehead.—The ornamental figure on the extremity of the upper stem-piece.

40. Stern-post.—The timber which forms the after extremity of the ship. It is fastened to the keel by tenon and mortise and is braced from within by the—

41. **Inner Stern-post**, and the
42. **After Dead-wood.**
43. **Main Transom.**—Horizontal pieces of timber which are bolted to the stern-post and form a part of the stern frame.
44. **Lower Transoms.**
45. **Rudder.**—The instrument by which the vessel is steered. It consists of several pieces of timber bolted together into a flat structure and hung by means of pintles and gudgeons or braces to the afterside of the stern-post.
46. **Rudder Stock.**—The main piece of the rudder. Its extension is cylindrical in shape and passes through the "rudder port" in the counter to a height above deck sufficient to connect the tiller by which the rudder is turned. The upper portion of the stock is called the "rudder head." The lower edge of the rudder is the "heel" and the upper part the "shoulder." The forward edge of the rudder is beveled to allow the required helm angle. To prevent the rudder from unshipping, a piece of wood called the "wood-lock" is placed in an aperture under the upper pintle. The after-edge of the rudder is often made concave to prevent vibration.
47. **Rudder Braces.**—Composition or copper sockets fastened to the stern-post to receive the pintles.
48. **Pintles.**—Composition or copper bolts with straps attached for fastening to the rudder. The bolts rest in the braces.
49. **Stern Frames.**
50. **Stanchions.**—Upright pieces of timber to support the decks.
51. **Breast-hooks.**—Large knees which are secured to the inner side of the apron and stemson with their arms running back across the timbers of the frame.
52. **Riders.**—Interior ribs which serve to strengthen the frame at the extremities of the ship.
- Garboard Strakes.**—The first two planks to be worked on the outside of the frame of a ship. The edge of the first garboard is rabbeted into the sides of the keel and into the stem and stern-post at the end. The garboard strakes are wider and thicker than the rest of the bottom planking.
53. **First Garboard.**
54. **Second Garboard.**
55. **Bottom Planking.**—The planks covering the frame between the garboard strakes and the bilge planking.
56. **Bilge Planking.**—The planks covering the frame at the bilge.
57. **Side Planking.**—(See Bends).
58. **Wales or Bends.**—The thickest planks on the outside. They extend from the main deck down to the turn of the bilge.
59. **Waist.**—The outside planking between the covering-board and the bends.
60. **Scupper.**—A hole cut through the water-ways and sides of the ship to carry off water from the decks.
61. **Covering-Board (or plank-sheer).**—Pieces of plank laid horizontally over the timber-heads, just above the water-ways, to cover the sides.
62. **Main Rail.**
63. **Bulwarks.**—The planking of a vessel above the upper deck.
64. **Chain Plates.**—Iron plates bolted to the outside of a ship to which are attached the dead-eyes.
65. **Dead-eyes.**—Pieces of hard wood having three holes through which the lanyards are rove for setting up the rigging.
66. **Channels.**—Pieces of oak plank bolted edgewise to the ship's side to give greater spread to the rigging, thereby affording additional support to the masts.

67. **Cat-head.**—A piece of timber secured to the topgallant-forecastle deck, having one end extending a short distance outboard and fitted with sheaves for reeving a purchase to secure the anchor and with some form of mechanical contrivance for letting it go. The part inboard is called the "cat-tail."

68. **Bowsprit.**

69. **Bits.**—Upright pieces of timber projecting above the decks, to which lines are made fast for towing, etc.

70. **Windlass Bits.**—Upright pieces of timber which support the barrel of the windlass.

71. **Windlass.**—A mechanical contrivance for raising the anchor. It consists of a horizontal cylindrical piece of wood, which is supported by the windlass bits. Around the middle of the barrel an iron ratchet band is placed, and two ratchet pawls fall in it as the barrel is turned. Upon each end of the barrel there are whelps, around which the chain is wound when heaving. The windlass is usually moved by hand-spikes inserted in holes in the cylinder, and an improved kind has pump-brakes, connected by rods to pawls in such a manner as to cause them to take in ratchets on the cylinder on the up and down strokes.

72. **Windlass Brakes.**—Long handles, serving the purpose of levers for working the windlass.

73. **Capstan.**—A machine used on shipboard for the purpose of increasing power when raising heavy weights. Greater compactness and convenience in use make it an improvement of the windlass. It consists of an upright cylinder of iron surmounted by a hemispherical drum-head, the circumference of which contains sockets for the admission of wooden or iron bars, by which the capstan is turned.

The lower part of the capstan is called the "pawl-head" and fits into a circular bed called the "pawl-rim." Around the base of the barrel short pieces of iron are secured by one end, leaving the other free to move in the direction in which the power is applied, over the tops of notches which form a part of the pawl-rim. When the power is removed the ends of the pawls drop by gravity against the notches, and by this means prevent the capstan from turning back.

The axis of the capstan consists of a vertical iron spindle which is fastened to the deck and holds the machine in place. Recent improvements in the capstan have added greatly to its power by introducing a system of gearing on the inside of the barrel which is brought into play by the action of a "lock-bolt."

When this gearing is utilized the barrel is turned in an opposite direction, the power is multiplied threefold, but at the sacrifice of time for the performance of the work.

Capstans constructed on various plans have almost entirely superseded the use of the windlass for raising the anchor, except in small vessels.

74. **Gypsy.**—An attachment on the windlass bits and sometimes placed at other parts of the ship for the purpose of increasing power when it is not convenient to use either the windlass or capstan.

75. **Gypsy and Windlass Pawls.**—Short iron-bars working on a ratchet band to prevent the backward motion of a capstan or windlass.

76. **Topgallant-forecastle Deck.**

77. **Forward Chock.**—That part of the forecastle rail which extends from the cat-heads to the knight-heads.

78. **Warping Chocks.**—Scores cut in the top of the forward chock to receive the lines used in warping.

79. **Mooring Chock.**—A large cleat fastened across the tops near the stern and pierced with a hole through which a cable is passed in mooring ship.

80. **Chain Stoppers.**—A mechanical device for preventing the chain from running out of the hawse-pipes.

81. **Pin-rail.**—Ledges of oak bolted to the inside of the main rail and pierced with holes to receive belaying-pins. **Fife-rail** is a rail for belaying-pins built around a mast. **Taffrail** is that part of the main rail around the stern of a ship.

82. **Diagonal Braces.**—Iron straps let into the outside of the frame timbers and extending from the floor timbers to the tops; used to give greater strength and rigidity to the hull. Diagonal braces were first introduced in ship building by Sir Robert Seppings about 1800. This officer was also the first to suggest the plan of filling in the spaces between the frames with solid timber as a means of preventing "hogging" of the ship's body.

83. **Belaying-Pins.**—Short cylindrical wooden pins usually made of locust for making fast the gear to the rails in the different parts of the ship.

84. **Forward Cants.**—The ribs which form the skeleton frame of the ship forward of the square-frame. Their heels abut upon the sides of the dead-wood.

85. **Limbers.**—Holes cut through the floor-timbers alongside the keelson to allow the passage of water to the pumps. **Limber boards** are boards placed fore and aft over the limbers. **Limber chains** are chains rove fore and aft through the limbers for the purpose of keeping them free from obstructions.

86. **Chain Hawse-Pipes.**—Iron pipes fitted into holes cut through the hawse-timbers to protect the wood from the chafe of the cables. In order to preserve the wood from the effects of iron rust the hawse-holes are first lined with lead.

Materials and Fastenings.

The frames should be of white oak, free from sap or decay; the timbers well seasoned and salted or pickled during the work of construction. The principal timbers should be of live-oak or other equally durable wood, and the "tops" of locust, hackmatack, or white-heart chestnut. Copper or composition bolts should be used in fastening the frames to the keel and the heels of the cants to the dead-wood.

The keel, stem, and stern-post should be of live oak, with scarfs not less than seven feet in length. The rabbets should extend sufficiently far to admit of fastening the wood-ends thereto. The keel should be of sufficient size to admit of twice the thickness of the outside planks between rabbets on the stem and stern-post. The lower piece of the stem should be a natural crook, attached to the keel by a hook scarf and strengthened by horseshoe straps of composition let in flush on either side and bolted through. The stern-post should step into the keel and be fastened by tenon

and mortise. The keelson may be of oak or yellow pine. It should be of the same size as the keel and fastened to it by copper or composition bolts driven through the keelson, each alternate floor-head and the keel. The scarfs of the keelson should be not less than six feet in length and shifted so that no scarf will be under the heel of a mast.

The beams are of oak or yellow pine and fastened to the sides by knees (natural crooks). The bosom and lodging knees must be of hackmatack and the hanging-knees of hackmatack or seasoned oak. The knees are fastened with through-bolts driven from the outside and clinched over rings, and with blunt bolts driven from the inside to within one inch of through. Each hanging knee should be keyed to the beam.

The inner stern-post and apron are of oak or pine and secured to the stern-post and stem, respectively, by copper bolts driven through and clinched over rings on the outside. The dead-wood must be of the best seasoned yellow pine, or other equally durable wood, and fastened with through-bolts driven from the inside and clinched over rings. Water-ways should be of oak or yellow pine, edge-bolted to the beams and timbers.

The outside planking must be of white oak or yellow pine and fit closely to each other on the inside.

The butts are usually fastened with copper spikes driven through the frame and clinched inside. Other parts should be fastened with locust treenails. The planks should be at least five feet long, and all butts on the same timber must have at least three planks between them.

Deck planks must be of white or yellow pine not less than 30 feet in length, free from "shakes" and knot-holes, and should be fastened with two copper or composition bolts in each butt, and one bolt in each beam or ledge which it crosses.

Garboard strakes should be of oak bolted to the floors with copper or composition bolts driven through frame and clinched, and edge-bolted through the keel in addition to treenailing. Bulwarks may be of white pine, and all interior joiner work of white pine, walnut, cherry, ash, maple, poplar, whitewood, etc., as may be desired.

In calking, the seams should be well filled with oakum thread 50 feet to the pound, and at least one thread to each half-inch of the thickness of the plank.

When old vessels are to be examined with a view to making repairs or to ascertain their condition for any purpose, particular attention should be directed to the state of the upper and main deck and coamings, the water-ways, beams, knees, and plank-sheer. The planking near the water-line and under the channels should be examined and the state of the seams with reference to the calking observed. One or two planks should be removed from the floor and the state of the frame, treenails and inside of the planking examined. In sailing ships the counter, rudder-post, mast-partners, timber-heads under bowsprit, the stern-post, and fore-foot are most liable to decay. In steamers the wood-work near the boilers, which is subjected to extremes of heat and dampness, is liable to dry-rot. Where decayed wood is suspected to exist the easiest and general way of ascertaining the condition is by boring.

Leaks are most likely to occur at the wood-ends, especially in vessels where the planks are much bent to conform to the model at the butts of planking and through treenails and seams of the planking under the channels.

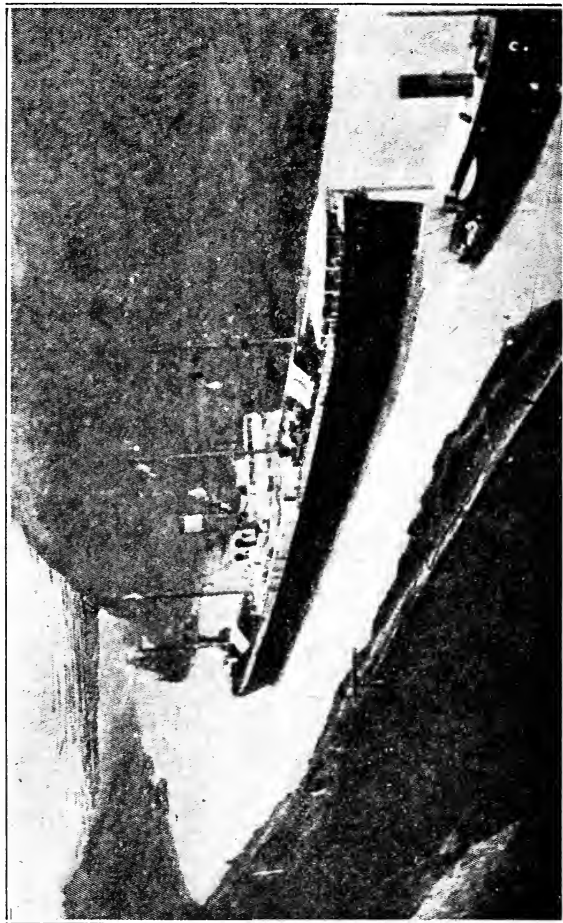

American-Hawaiian Liner MISSOURIAN, 20,000 tons displacement,
Passing through "Cucaracha Slide" in the Panama Canal.

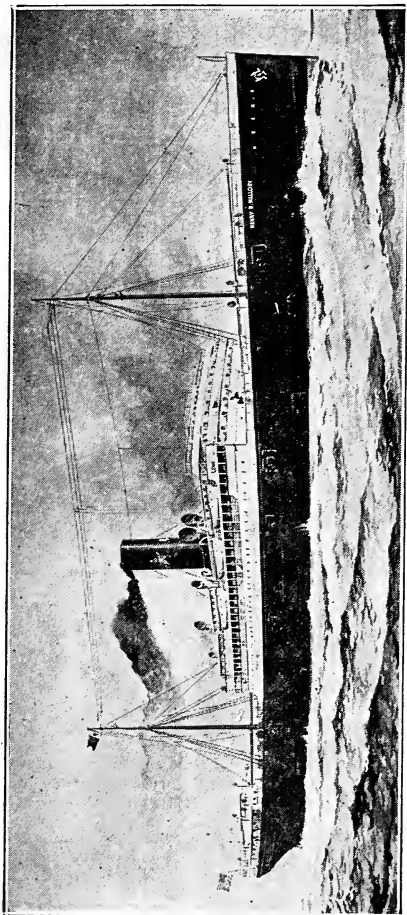

Mallory Line Steamer "HENRY R. MALLORY" 11,000 tons displacement.

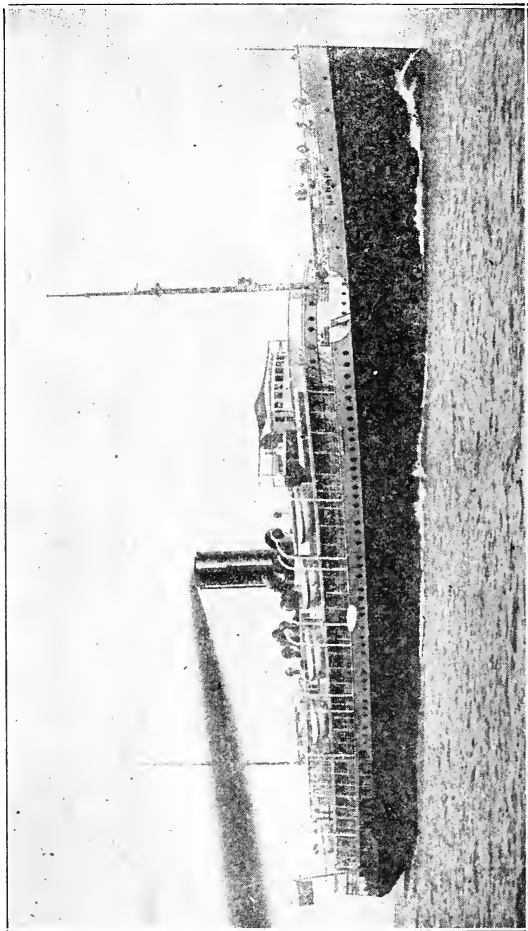

Clyde Liner "LENAPE" 8,000 tons displacement.

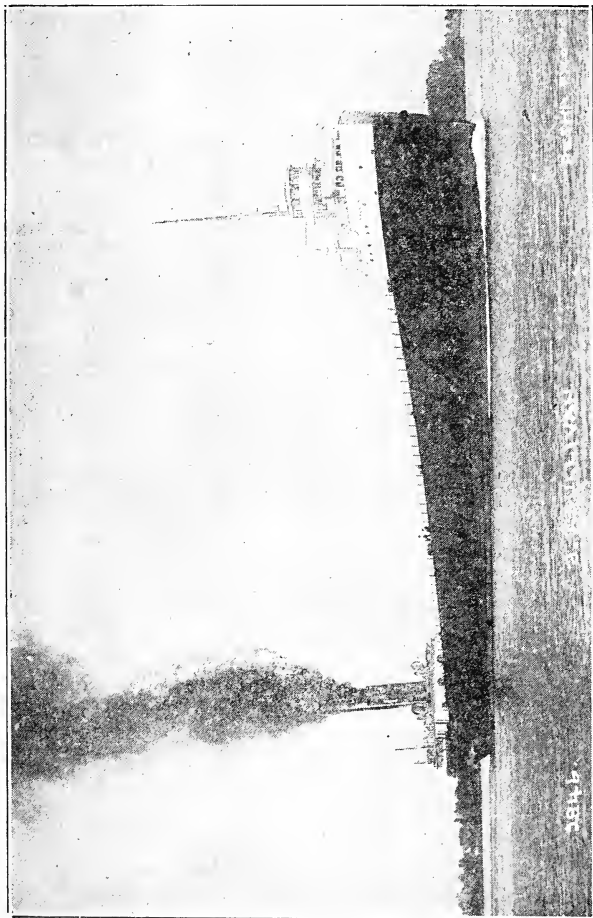

Typical Great Lakes Cargo Carrier

41884

THE DIFFERENCE BETWEEN GROSS AND NET TONNAGE.

The near-landsman is often confused as to the exact difference between the gross tonnage, net tonnage and displacement of vessels. All mercantile nations have agreed to consider the gross tonnage of a vessel its entire interior capacity, measured in tons of 100 cubic feet.

The net tonnage is the figure obtained by subtracting from the gross tonnage the space utilized by the officers' accommodations, crew and gear for working the ship; and, in the case of a steamship, all her propelling machinery, such as boilers and engines. The net tonnage of a ship is therefore the space used for carrying passengers or cargo.

Naval vessels, and also merchant ships, are rated in size according to the weight of the water in tons displaced by the ship when loaded to their displacement. The displacement of a ship is the weight of the water displaced by the ship when loaded to its normal load water line. In the case of a dreadnaught the displacement only varies as the quantity of coal or oil aboard decreases, or increases when reloading. With a merchant ship the displacement varies by the amount of cargo which it may carry. When light the displacement is equal to the weight of the ship. When loaded the displacement is equal to the weight of the ship and cargo. The quantity of water displaced in tons is, under all circumstances, equal to the weight of vessels and cargo so long as it floats. When a ship sinks, then the weight of the vessel is greater than the weight of the water which it displaces. It is impossible for a ship to displace a weight of water less than its own weight, else it would rise. In other words, the weight of the ship and cargo which is the downward force tending to sink it, is always equal to the upward pressure of the water.

The general public, which is not familiar with the distinction between these terms, is likely to believe that war ships are much larger than the great ocean liners, since the size of the former is expressed by displacement while the size of the latter is usually expressed by their carrying capacity or gross tonnage. As a matter of fact, the largest war ships are smaller than the largest ocean liners.

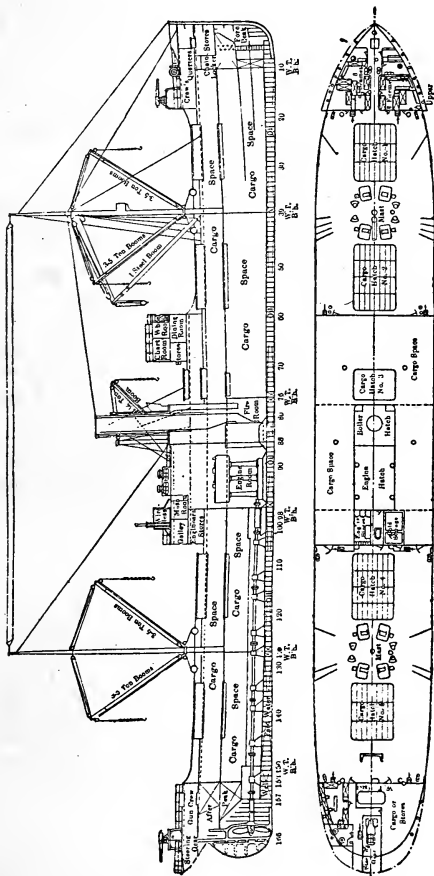

Longitudinal Section.
 Emergency Fleet Standard Steel Steamship.
 7,300 tons dead weight capacity. 11½ knots sea speed.

DESIGN AND CONSTRUCTION

OF

STEEL MERCHANT STEAMSHIPS.

EMERGENCY FLEET STANDARD STEEL STEAMSHIP.

This vessel is of the single-screw type with straight stem and elliptical stern, schooner rigged with two steel pole masts. The hull is built on the transverse system with two steel decks and a raised forecastle, long bridge and a full poop.

A complete double bottom, subdivided into five compartments longitudinally, is fitted throughout the length of the vessel. The compartments under the machinery space and under holds Nos. 1, 2 and 3 are arranged for storing fuel oil, while the compartments under hold No. 4 are arranged for feed water.

Six watertight bulkheads divide the hull into seven watertight compartments; four of the bulkheads extend to the upper deck and two to the main deck. Cargo is handled through five hatches in the upper and main decks and one cargo hatch in the bridge deck. There is also a hatch in the poop deck and one under it in the upper deck to the after peak.

GENERAL ARRANGEMENT.

As can be seen from the plans, the machinery, which consists of a triple expansion reciprocating engine driving a single screw, is located amidships with two main boilers abreast and a screen bulkhead built around them at their after end to separate the boiler and engine rooms. Side bunkers for fuel oil are fitted below the main deck in the engine and boiler rooms, in addition to the double bottom compartments arranged for oil storage.

Accommodations for the captain, deck officers, engineers, etc., are provided in deck houses on the bridge deck. Quartermasters, boatswain, mess boys, seamen and firemen are berthed in the forecastle. Quarters for the gun crew with wash room are provided in the poop.

HULL CONSTRUCTION.

The framing of the vessel is on the transverse system with two steel decks in the hull. The decks are supported by girders and deep beams with one row of wide-spaced pillars. The side frames



SECTION THRU, HOLD NO. 3 & 4

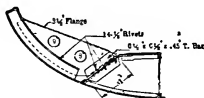

SECTION THRU, HOLD NO. 1

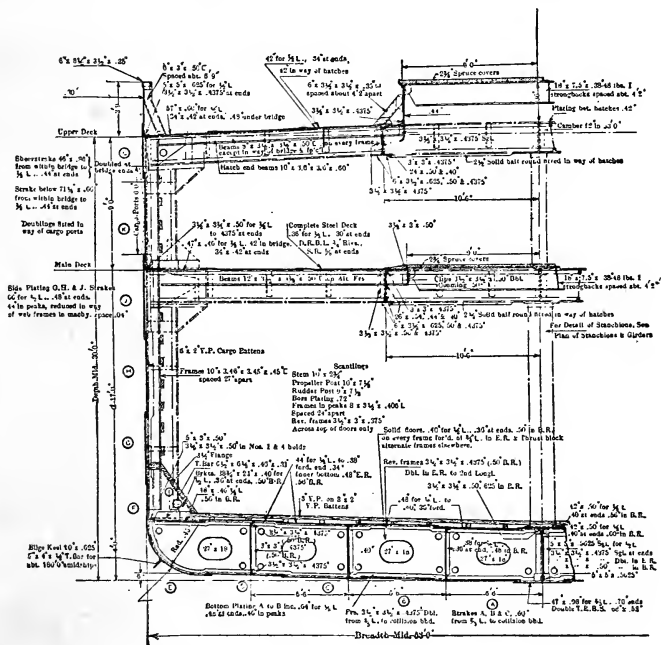

Midship Section.
Standard Steel Steamship.

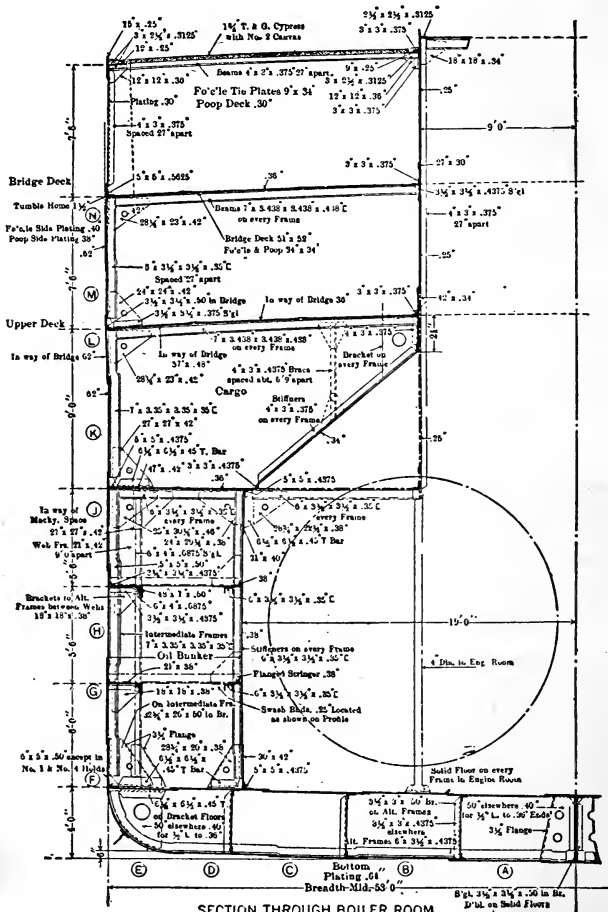

are cut and bracketed at the main deck in way of the bunkers, so that the lower bunkers may be made oil tight. All scantlings are as indicated on the midship sections.

The stem is a flat steel bar made in sections and the stern frame is of cast steel in one piece.

Complete steel decks are fitted on the main and upper decks, bridge and poop and stringers and tie plates on the forecastle. The main deck is carried through in way of the machinery casings and is oil tight over the bunkers.

In addition to the six watertight bulkheads, steel bulkheads are fitted at the forward and after ends of the bridge and the forward end of the poop and around the quarters in the forecastle.

These vessels are designed in regard to boiler equipment in such a manner that the boilers may be firetube, either for coal consumption or fuel oil; or watertube boilers may be used if desired.

COMPOSITE STEAMSHIP CONSTRUCTION.

The term "composite" as used in ship construction, generally means construction in which are used both wood and steel. In a general way the planking is of wood and the reinforcing parts, such as framing, angles, pillars, etc., are of metal.

The composite steamer is designed to provide a ship which can be economically constructed in spite of the scarcity of material.

Another very important feature of a composite vessel is the saving for cargo space made possible by the substitution of steel for wood.

Ships three hundred feet long can be built according to this method with perfect safety and it is estimated that the saving of space by using steel rather than wood in a vessel of this size would be considerably in excess of three hundred tons. The diagram here shown will give a general idea of the application of the principle of composite construction.

It is a well known fact that the larger the ship the less the cost to construct and operate per ton of carrying capacity. The fact that there is a limit beyond which the size of the all-wooden ship cannot be carried practically, is the principal handicap which that type has to meet, therefore, for economy it is necessary to turn to a substitute approaching the all-steel ship. Advocates of this type of construction claim a very considerable saving in cost of construction. Some vessels of the composite type are designed so that the wood planking can be removed and steel plating substituted, thus converting the vessel into a standard steel ship. It has also been suggested that the steel frame and reinforcements may be used and concrete substituted for the wood planking.

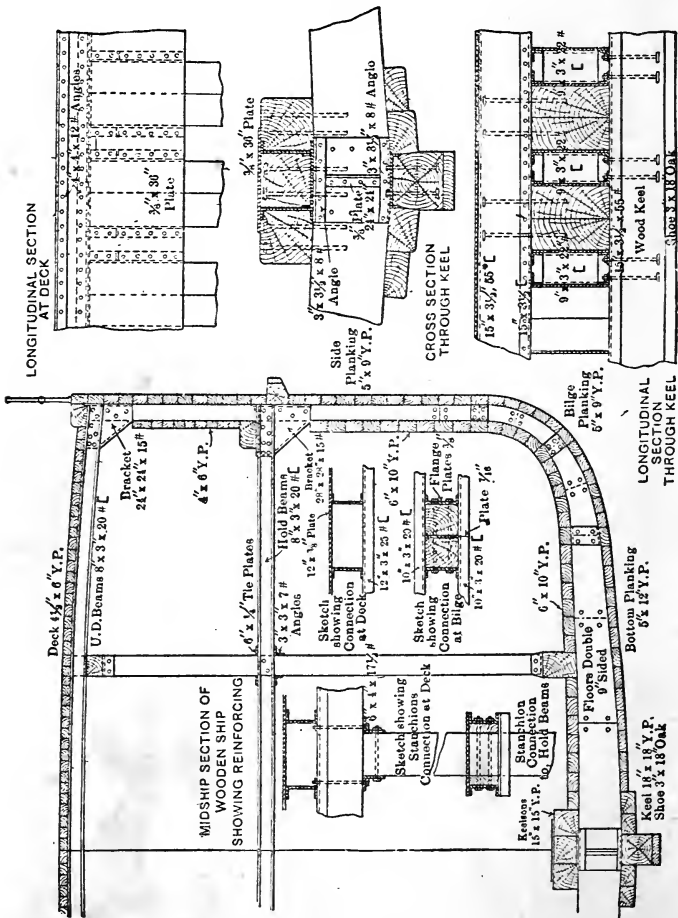

STOWAGE OF CARGO.

The proper stowage of a ship's cargo is one of the most important duties of a ship's officer. A cargo improperly stowed may not alone result in damage to the cargo, but may result in damage to the ship or perhaps cause loss of the vessel, due to the cargo shifting, causing the vessel to capsize.

At many of the ports visited by Merchant Ships, competent stevedores are not obtainable, the ships in these cases being loaded and discharged by the ship's crew. A knowledge, therefore, of this important work is necessary, so that the seaman may perform these duties intelligently and thereby, be of value to the officers of the ship in which he serves.

STABILITY OF SHIPS

A ship's stability depends upon her form, the weight of her superstructure, and the distribution of her equipment, cargo, stores, fuel and ballast.

Many ships have been designed without sufficient stability when light, to float in an upright position. The fact that vessels so designed sail the seas is not alarming, for these vessels when obliged to proceed without cargo are always loaded with sufficient ballast to make them stable. With the modern vessels, a water bottom, or double bottom so-called, is provided for carrying water ballast.

If a vessel's form and the distribution of the weights on board is such as to give her considerable stability, the vessel is termed stiff. If on the other hand, the vessel possesses small righting-leverage, she is said to be crank, or tender.

By the term stability is meant the moment of force (usually measured in foot tons or inch tons) with which a vessel, when inclined from the upright position by the action of the wind or by some other external force, immediately endeavors to right herself, or in other words if a vessel is heeled by the application of some external force the effort she possesses to return to the upright is her stability.

A stiff vessel is inclined to roll more quickly in a seaway than a tender vessel; and may cause damage by straining the structure and causing leakage, or by jerking her masts overboard. Dismasting due to this cause was not uncommon when broad-beamed sailing-ships were so ballasted as to produce over-stiffness. The tender vessel rolls slowly and her motion is easier. Passenger liners are often designed as tender ships, to make their motion in a seaway easy for the comfort of the passengers.

The above brief description of the stability of ships will give a general idea of the effect the stowage of cargo will have upon the vessel's behavior in a seaway.

GENERAL CARGO

Before the actual work of stowing the cargo begins, the ship should be prepared to receive it, for after being loaded, many of the internal parts of the vessel will be inaccessible and to insure that the cargo will be delivered at its destination in an undamaged condition, it is therefore, necessary to clean the holds and to see that the limbers, scuppers, strainers and pump wells are clear.

When the cargo is received alongside, it is the duty of the chief officer to direct its stowage and determine where it shall be placed, having in mind the stability of the vessel and the proper location for the heavy weights such as machinery, casks, cases, iron rails, or other heavy articles.

In a tender vessel, the heavy weights should be placed in the lower hold, and the lighter weights above. While in a stiff vessel, the heavy weights should be placed higher than in a tender vessel.

While the above is a general rule, the best results will be obtained if the officer in charge has an intimate knowledge of the vessel's stability, for he may then load the vessel with the assurance that the vessel will be stable when loaded and yet not so stiff as to cause violent rolling in a seaway.

BARRELS

Barrels should be stowed fore and aft in straight tiers with the bung up, and bilge free. If stowing cargo while in darkness it is well to remember that the bung is always to be found in line with the rivets in the hoops.

Barrels containing oil, or any liquid substance should be stowed under and clear of all cargo it could damage in the event of leakage.

CASES

Cases are stowed, marks and numbers up, the side which bears the marks and numbers is called the top.

BALES

Bales are stowed flat, amidships, with marks and numbers up, or on edge in the wing, with marks and numbers inboard.

IRON RAILS

Great care should be exercised in stowing a cargo of this nature, to prevent its shifting in a seaway.

It should be stowed grating fashion, and shored down from the deck beams.

CARBOYS

Carboys containing acids, gas or ether, should be stowed on deck, so that they may be thrown overboard in case of leakage.

DUNNAGE

To properly stow a general cargo, it should be dunnaged. A good rule for using dunnage is as follows: nine inches on floor, fourteen inches in the bilge, three inches in the sides and two inches on the between decks.

Dunnage is placed fore and aft in the lower hold and athwartships in the between decks, so that water may have free passage.

Regulations Regarding Carrying Dangerous Articles

SEC. 4472. No loose hay, loose cotton, or loose hemp, camphene, nitroglycerin, naphtha, benzine, benzole, coal oil, crude or refined petroleum, or other like explosive burning fluids, or like dangerous articles, shall be carried as freight or used as stores on any steamer carrying passengers; nor shall baled cotton or hemp be carried on such steamers unless the bales are compactly pressed and thoroughly covered and secured in such manner as shall be prescribed by the regulations established by the board of supervising inspectors with the approval of the Secretary of Commerce; nor shall gunpowder be carried on any such vessel except under special license; nor shall oil of vitriol, nitric or other chemical acids be carried on such steamers except on the decks or guards thereof or in such other safe part of the vessel as shall be prescribed by the inspectors. Refined petroleum which will not ignite at a temperature less than one hundred and ten degrees of Fahrenheit thermometer, may be carried on board such steamers upon routes where there is no other practicable mode of transporting it, and under such regulations as shall be prescribed by the board of supervising inspectors with the approval of the Secretary of Commerce; and oil or spirits of turpentine may be carried on such steamers when put up in good metallic vessels or casks or barrels well and securely bound with iron and stowed in a secure part of the vessel; and friction matches may be carried on such steamers when securely packed in strong, tight chests or boxes, the covers of which shall be secured by locks, screws, or other reliable fastenings, and stowed in a safe part of the vessel at a secure distance from any fire or heat. All such other provisions shall be made on every steamer carrying passengers or freight, to guard against and extinguish fire, as shall be prescribed by the board of supervising inspectors and approved by the Secretary of Commerce.

HOMOGENEOUS CARGOES

By a Homogeneous Cargo is meant one entirely composed of the same nature, such as a complete cargo of cotton, or coal, or wool, or grain.

GRAIN

When grain is carried, it must be kept absolutely dry. Should it become wet, it is apt to swell and burst the vessel's decks.

Shifting boards must be provided to prevent the cargo from shifting in a seaway.

Grain cargoes are generally loaded under the direction of an insurance surveyor.

COAL

A cargo of coal is stowed to the deck between the beams and to the ship's sides; and when properly trimmed, is not liable to shift in a seaway.

When coal is being carried on long voyages, the temperature in the various portions of the cargo should be frequently tested to guard against the danger of spontaneous combustion. The holds should be properly ventilated and during fine weather, the hatches removed.

LOAD-LINE MARKS, DRAUGHT OF WATER, AND FREE-BOARD, ADOPTED BY THE BRITISH BOARD OF TRADE.

At the present time no standard requirement is in force providing for load-line marks on American vessels. The following regulations commonly called "Plimsoll" marks are given for information and are those issued by the British Board of Trade.

The lines to be used in order to indicate the maximum load-line under different circumstances and at different seasons shall be nine inches in length and one inch in thickness, and the maximum load-line shall be the upper edge of each of such lines.

The said lines shall be horizontal lines marked on both sides of the ship, extending from and at right angles to a vertical line marked 21 inches forward of the centre of the disc. The maximum load-line in fresh water shall be marked abaft such vertical line, and the maximum load-lines in salt water shall be marked forward of such vertical line, as shown in the following diagrams:

FOR STEAMSHIPS.

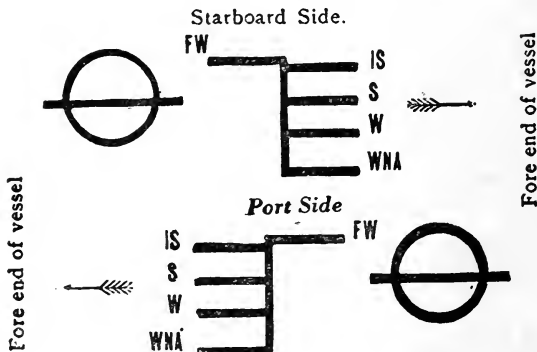

The arrow (—>) points in the direction of vessel's head. Such maximum load-lines shall be distinguished by initial letters permanently and conspicuously marked opposite such horizontal lines as aforesaid, such initial letters being as follows:—

F. W.—Fresh Water.

I. S.—Indian Summer.

W.—Winter.

W. N. A.—Winter, North Atlantic.

The upper edge of the horizontal line passing through the centre of the disc shall always indicate the summer freeboard in salt water.

STATION BILL

A station bill is a notice, giving definite information as to the post or station of duty of every person employed on board the steamer in case of fire, or abandoning ship and will be found posted in various accessible parts of the vessel, and it remains the imperative duty of every person employed on board to acquaint himself with his station of duty and the nature of the alarm signals used.

General fire alarm signal shall be a continuous rapid ringing of the ship's bell for not less than twenty (20) seconds, and this signal shall not be used for any other purpose whatsoever. The master of any steamer may establish such other emergency signals in addition to the ringing of the ship's bell, as will provide that all officers and crew of the steamer will have positive and certain notice of the existing emergency.

General Instructions for Fire Drill

1. Upon hearing the signal for fire quarters, each member of the crew will take a station quickly, quietly, and without crowding or confusion.

2. Upon hearing the alarm, attend to your specific duty, which may be any of the following:

- (a) Leading out and clearing away hose.
- (b) Seeing that nozzles are coupled and secure.
- (c) Opening valves to fire lines.
- (d) Hand pumps clear for operating.
- (e) Water tight doors closed.
- (f) Fire extinguishers taken from racks and to stand by for instructions.
- (g) Standing by with filled water buckets.
- (h) Standing by with fire axes under direction of Chief Officer or Master.
- (i) Standing by to assist passengers and distributing life preservers.
- (j) Attending and turning on emergency lights distributed throughout the vessel.
- (k) Starting fire pump under direction of engineer.

3. Attention is called to the fact that each master of a vessel may have individual ideas of the method of conducting drill and the assignment of crew. Also, it devolves upon each member of the force on board to learn thoroughly the method used on the particular vessel on which he serves and abide by the wishes of the master.

4. Upon the conclusion of fire drill—"Secure" is usually given by one stroke of ship's bell, and upon hearing this signal each member of the crew will stand by at his station for the "dismissed" signal.

General Boat Alarm Signal may be six short blasts of steam whistle or sounding on the siren.

STATION BILL

USED ON STEAMSHIPS OF THE

International Mercantile Marine

MUSTER LIST.

The alarm of Fire will be the Rapid Ringing of ship's bell followed by 1 tap if fire is Forward, 2 taps if fire is Amidships and 3 taps if fire is Aft. All members of Crew, excepting those specially excused on account of being on Duty which cannot be avoided, must immediately proceed to their stations, and stretch out the hose and otherwise see that the apparatus under their charge is ready, and remain by same until further orders.

Men in charge of Bulkhead Doors will immediately close same and keep them closed until further orders.

Alarm Blasts on the Steam Whistle (1 long and 4 short blasts) calls every member of Crew (except those unavoidably on duty elsewhere) to the Boat stations. The men must muster at their boats as quickly as possible and remain there, taking their orders from the Officer or Seaman in charge of the boat.

The ringing of the Electric Alarm Bell means that for some urgent reason all members of Crew must immediately leave their quarters and muster in an orderly manner on the lower deck awaiting further orders.

Boat Numbers	DECK DEPARTMENT		ENGINE DEPARTMENT		PASSENGER DEPARTMENT	
	Boat Station	Fire Station	Boat Station	Fire Station	Boat Station	Fire Station
No.	Commander (A.B.)	In charge of ship	1st Asst. Engineer	In charge boiler room	Purser	Muster passengers & control dept.
	Stonkskeeper (A.B.)	Forward hand fire pump	Oilier		Surgeon	In dispensary
	Marconi Operator	Remains at post	Firman No. } Coalpasser No. }	On duty remain at post	Stewardess No.	Warm passengers section
	Boat Handler No. " " No. " " No.	Fire station under the department you belong to		Off duty muster on lower deck	" "	Bullhead door section
No.	Quartermaster No.	Proceed to the bridge	Engineer	Bullhead door No.	Cook No.	Life belts in section
	In charge	Muster under bridge	Oilier			Stretch base in galley
	Able Seaman No.		Firman No. } Coalpasser No. }	On duty remain at post	Steward No.	Bullhead door section
	Boat Handler No. " " No. " " No.			Off duty muster on lower deck	" "	Life belts section
No.	Licensed Engineer		Chief Engineer	In charge of department	Cook No.	Hose nozzle in galley
	In charge		Oilier		Chief Steward	Assemble passengers, etc.
	Able Seaman No.		Firman No. } Coalpasser No. }	Off duty remain at post	Stewardess No.	Warm passengers
	Boat Handler No. " " No. " " No.			Off duty muster on lower deck	" "	Bullhead door section
No.	Quartermaster No.	Proceed to bridge	Engineer	Bullhead door No.	Cook No.	Life Bella section
	In charge	Muster under bridge	Oilier			Fire bucket fore square
	Able Seaman No.		Firman No. } Coalpasser No. }	On duty remain at post	Steward No.	Warm passengers section
	Boat Handler No. " " No. " " No.			Off duty muster on lower deck	" "	Life bella section
No.	First Officer	Attend to stretching line	Engineer		Cook No.	Fire bucket fore square
	In Charge	Muster under bridge	Oilier		2nd Cabin Steward	Assemble and control passengers
	Able Seaman No.		Firman No. } Coalpasser No. }	On duty remain at post	Stewardess No.	Warm passengers section
	Boat Handler No. " " No. " " No.			Off duty muster on lower deck	" "	Bullhead door section
No.	Able Seaman No.	Keep promenade deck orderly	Engineer		Cook No.	Life belts section
	In charge	Muster under bridge	Firman No. } Coalpasser No. }	On duty remain at post	Steward No.	Fire bucket fore square
	Able Seaman No.			Off duty muster on lower deck	" "	Warm passengers section
	Boat Handler No. " " No. " " No.				Steward No.	Life belts section

STATION BILL—Continued

No	Boatswain In charge	Muster under bridge	Engineer	On duty remain at post	3rd Class Steward	Automb and control passengers
	Able Seaman No.		Oiler			
No.	Boat Handler No.	Muster under bridge	Fireman No.	Off duty muster on lower deck	Cook	Bulkhead door section
	" " No.		Coopasser No.			
No.	Able Seaman No.	Proceed to bridge	Engineer	On duty remain at post	Cook	Fire bucket fore square
	Able Seaman No.		Fireman No.			
No.	Boat Handler No.	Muster under bridge	Coopasser No.	Off duty muster on lower deck	Cook	Stretch hose section
	" " No.		" " No.			
No.	Third Officer In charge	Keep lower deck clear and orderly	Engineer	On duty remain at post	Cook	Hydrant key section
	Able Seaman No.		Fireman No.			
No.	Deck Cadet No.	Muster on bridge	Coopasser No.	Off duty muster on lower deck	Cook	Warm passengers section
	Boat Handler No.		" " No.			
No.	Licensed Engineer In charge	Carpenter to report to City Officer at fire	Engineer	On duty remain at post	Cook	Stretch hose section
	Carpenter		Fireman No.			
No.	Boat Handler No.	Muster under bridge	Coopasser No.	Off duty muster on lower deck	Cook	Hydrant key section
	" " No.		" " No.			
No.	Lookout (A.B.) In charge	Muster under the bridge	Engineer	On duty remain at post	Cook	Fire extinguisher section
	Able Seaman No.		Fireman No.			
No.	Boat Handler No.	" " on bridge	Coopasser No.	Off duty muster on lower deck	Cook	Hose nozzle section
	" " No.		" " No.			
No.	Fourth Officer In charge	After band fire pump	Engineer	On duty remain at post	Cook	Fire bucket fore square
	Motor Engineer		Fireman No.			
Motor	Deck Cadet	1 Boat Handler No.	Coopasser No.	Off duty muster on lower deck	Cook	Hose nozzle section
	2 " " No.		" " No.			
Motor	3 " " No.	" " " " No.	" " No.	Off duty muster on lower deck	Cook	Hydrant key section
	" " " " No.		" " No.			

N.B.—Captain will have Numbers of boats inserted in proper rotation ; also the Numbers indicating the member of the Crew

MUSTER LIST

The Muster List herewith assigns duties to the different members of the CREW in connection with:

- A. The closing of the water-tight doors, valves, etc. Carpenters, Deck, Engineer, Engine, Steward, Cabins.
- B. The equipment of the boats and rafts, generally, to Chief Officer and Junior Officer.
- C. The launching of the boats attached to davits, An Officer or Able Seaman.
- D. The general preparation of the other boats and rafts, Chief Officer and Junior Officer.
- E. The muster of passengers. Purser and Chief Steward.
- F. The extinguishing of fire. Chief Officer.

The Muster List herewith assigns to the members of the STEWARD'S DEPARTMENT their several duties in relation to passengers at a time of emergency.

These duties shall include:

- A. Warning the passengers. Stewardesses.
- B. Seeing that the passengers are dressed and have put on their life jackets in a proper manner. Bedroom Stewards.
- C. Assembling the passengers. Chief Steward and Senior Assistant Stewards.
- D. Keeping order in the passages and on the stairways and, generally, controlling the movement of the passengers. Purser and Asst. Stewards.

The Muster List specifies definite ALARM SIGNALS for calling all the CREW to the BOAT and FIRE STATIONS.

Notes for Boat Handlers to Remember for Launching Boats

1. Muster at Stations. Put on life-belts.
2. See that the boat-falls are made fast.
3. Remove boat covers and boat-falls, pass out painters, and see that boat-falls are clear for running.
4. Cast adrift gripes.
5. Heave on boat-falls to take weight of boat.
6. Turn down chocks.
7. Cast adrift guys and heave out boat.
8. Man boat and lower away on both tackles.
9. Either lower boat right into the water or to the passenger deck rail to embark passengers as the Commander may direct.
10. When lowering the boat into the water, let go both boat-falls directly the boat touches the water. Release gear. The two men lowering the boat will slide down the falls into the boat as soon as she is in the water and the falls let go.
11. Where a second boat is to be launched from the same davits the second boat's crew will have her all prepared (cover off, gripes adrift, etc.) during the lowering of the first boat, and as soon as the first boat is away they will round up the falls and launch their boat.

N. B. — Members of the Crew must recognize the man appointed to be in charge of the boat, whether officer or seaman, he must be recognized by the boat's Crew as being in charge.

General Instructions for Boat Drill

1. Upon hearing the signal for "abandoning ship," each member of the crew will take his station quickly, quietly, and without crowding or confusion.

2. Upon hearing the alarm, attend to your specific duty, which may be any of the following:

- (a) Attending forward or after boat fall, clearing away same and making ready for running.
- (b) Removing boat cover and casting off gripes.
- (c) In boat and put on cap of automatic plug.
- (d) Taking out or releasing boat chocks.
- (e) Casting off forward or after guys after the boat is hoisted and rehooking after boat is swung out.
- (f) In boat and bearing off when being lowered.
- (g) Securing side ladder.
- (h) In boat and casting off releasing hook lanyards or standing by releasing gear lever.
- (i) Directing passengers and assisting in the distribution of life preservers.
- (j) Casting off the lashings of life rafts.
- (k) Attending painter of boat or raft.

3. Attention is called to the fact that each master of a vessel may have individual ideas of the method of conducting drill and the assignment of crew. Also, it is incumbent upon each member of the force on board to learn thoroughly the method used on the particular vessel on which he serves and abide by the wishes of the master.

4. Upon the conclusion of boat drill "Secure" is usually given by one stroke of ship's bell, and upon hearing this signal the boats are hoisted, swung in and replaced in their chocks. The crew will then stand by for "dismissed" signal.

Miscellaneous Remarks on Duties at Fire and Boat Drill

1. If you do not understand your duties explicitly, request one of the mates or instructors to explain them to you.
2. When leading out hose, see that there are no kinks.
3. See that the brakes are set on hand pump.
4. Do not invert fire extinguishers until ready for action.
5. Drain hose before coiling.
6. Be sure you know the proper method of belaying a fall and lowering away a boat by means of a turn on the davit cleat.
7. Proper method of adjusting the boat plug, and of handling releasing device should be understood.
8. Do not give commands to others but obey those given by the officer in charge of your fire squad or in charge of your particular boat.
9. If a signal is heard by you, quickly determine if fire or boat alarm.

General Definitions of Ordinary Terms Used in Fire and Boat Drills

Spanner: An instrument used for coupling or uncoupling hose to fire plug.

Fire main: Line of piping throughout a vessel, connected with fire pump and various outlets or fire plugs.

Steam smothering pipe: Connections for conveying steam to various holds of vessels, operated by series of valves on deck or in or near the engine department.

Sprinklers: System of perforated piping for the purpose of distributing water throughout the vessel to aid in extinguishing fire.

Manifold: Central distributing point from which various lines of piping lead to different sections of vessel to convey steam or water.

Automatic boat plug: Arrangement fitted in bilge of boat to permit of the freeing of water automatically.

Releasing gear: Arrangement fitted to forward and after ends of boat to release boat from falls.

Equipment: Various articles required to be carried in each lifeboat.

Chock: Arrangement under boat—similar to cradle—which holds boat in position and upright on deck.

Belay: Make fast the boat fall.

Breast off: Hold boat clear of side of vessel when boat is being lowered or hoisted.

Guys: Fastenings secured to davit heads and leading to deck to hold davits in position.

Span: Fastening between davit heads.

Take a turn: Take a turn around davit cleat.

Slack away handsomely: Ease slowly the fall by means of the cleat.

Painter: Rope attached to bow of lifeboat, by means of which the boat may be held in position alongside of vessel when in the water.

Life lines: Ropes attached to span used as means of steadying boat when being lowered to water.

BOAT SERVICE

The following words are the orders given by the coxswain or officer of a boat to the crew, under various circumstances, to produce a desired effect.

Give Way: To commence rowing.

Hold Water: To impede the boat's progress by keeping the blades of the oars in the water in a vertical position, and at right angles to the keel.

In Bows: To cease pulling the bow oar and to lay it down fore and aft within the boat, the blade forward.

Let Fall: To let the oars drop from the vertical to the horizontal, the loom resting in the rowlock, the blade held out of the water and horizontal, the oar itself at right angles to the keel.

Oars: To cease rowing and to maintain the oars in the same position that they are in after executing the order "Let Fall."

Ship Oars: To lift trailing oars out of the water alongside, and hold them as described for "Let Fall."

Shove Off: To force the boat away from a vessel's side or from a wharf or float.

Stern All: To row the boat backwards—the opposite to "Give Way."

Toss: To lift the oars out of the water and lay them down within the boat fore and aft, the blades forward.

Trail: To throw trailing oars out of the rowlock and allow them to trail alongside by their lanyards.

Up Oars: To raise the oars to the vertical, the blades kept fore and aft—a preface to the order "Let Fall."

Way Enough: To cease rowing, and to lift the oars out of the water and boat them at the coxswain's word, "Toss."

DUTIES OF COAL PASSERS, FIREMEN WATER-TENDERS AND OILERS.

COAL PASSERS

Duties on Going on Watch

On being called to go on watch, the coal passer reports, together with the firemen of his watch, to get out ashes that have accumulated in the fire room during the previous watch. This is done before 8 bells.

At 8 bells, the coal passer goes on watch and assists the firemen in cleaning of the fires. As the firemen haul out clinkers and ashes from the fires, the coal passers wet them down with water from the fire room hose. When fires are cleaned, the coal passer hauls ashes from ash pits and shovels all ashes away from the fronts of the boilers to a place provided for same.

During the watch he keeps the firemen supplied with coal from the bunkers. On first leaving port, the coal runs out of the bunker doors but in a short time the coal has to be brought out of the bunkers.

When time arrives for getting out the ashes that have accumulated during his watch it is the coal passer's duty to fill the ash buckets for the next watch to hoist and dump overboard. If the vessel is fitted with ash ejectors he shovels the ashes in the hopper.

In port, the coal passer sweeps the tubes, cleans out the back connections, scales and cleans the inside of the boilers, and does such general cleaning and similar work, under the direction of the engineer in charge of the fire rooms, as may be required.

FIREMEN

Duties on Going on Watch

Where no ash ejector is fitted, the firemen report to get out ashes that have accumulated during the previous watch. This is done before 8 bells. At 8 bells, the firemen go on watch and clean the fires that have been burned down by the firemen who are relieved. This is done in one of two ways; either by working the fire all over to one side of the furnace with the slice bar, and hauling out the clinker and ashes from the grates on the other side with a hoe, then working the fire back to the clean side of grates with the slice bar and hauling out clinker and ashes from the other side; the fire is then spread over the entire grate, and covered with coal. The other way is to shove all the fire to the back half of the furnace with the cleaning hoe, haul out the ashes and clinker from the front of the grate bars, then haul the good fire on the clean front grate bars, and haul out the ashes and clinker from the back half of the grate bars over the top of the fire in the front. The fire is then spread over the entire grate bars and covered in the same manner. It is customary and better practice to have a supply of broken lumps of coal to cover the fire after cleaning, as this permits a freer passage of air through the fire, thereby hastening the building up of the fire.

Firing soft or bituminous coal consists of 3 operations, covering, slicing and raking. The coal is thrown on the front half of

the fire, where it cakes and cokes. The fire is then broken up with the slice bar, which is a long bar of iron, pointed on one end with a handle on the other. This is passed under the fire directly on the grate bars and on bearing down on the outer end the bar passes up through the fire, breaking up the caked mass, thus allowing a free passage of air through it.

In a short time, the coked fuel in the front, which is now a glowing mass of fire, is shoved to the back end of the fire with a small hoe or a clinker hook. A clinker hook is made with prongs on the end instead of a blade, as a hoe has. These operations are carried on in uniform regularity, and are summed up in the "formula" shovel, slice and rake. In firing soft coal, it is necessary to insert the slice bar under the clinker which forms on the grate bars and clogs the air passages through the bars.

A short time previous to the end of the watch, usually 15 to 20 minutes, the fireman burns down the fires that are to be cleaned by the fireman who relieves him. This is simply not putting any fresh coal on the fire and working it with the slice bar and clinker hook, as above described, until it is partly burned out, so as to leave only sufficient fire to be easily shoved to one side or to the back end of the furnace, and have sufficient to start a new fire. Care must be taken that this is not done too soon, or the fire will be burned down so low as to be useless for the purpose of making steam.

In port, the fireman has various duties to perform. He is usually detailed to the engine room, and keeps all bright work on the engines cleaned, brass work polished, paint scrubbed, does whatever painting is done in the engine room. He also assists in the overhauling of the engines, his part of the work consisting of manipulating the hoisting gear used in raising and lowering cylinder heads, journals, etc. He does all the tightening up of the nuts on the bearing bolts, which is done with a sledge hammer. In doing this work he has a splendid opportunity of learning how this very important work is performed, a knowledge that is absolutely necessary for a man to obtain before he can be promoted to a higher position.

A fireman must also be prepared to perform any duties that he is directed to perform by his superior officers. On watch he is under the direct supervision of the water tender in his fireroom, and also under the engineer who is in charge of the firerooms. In port, he is under the supervision, when detailed to the engine room, of the assistant engineer in charge of the work.

OILERS

Duties on Going on Watch

An oiler goes down in the engine room 15 or 20 minutes before 8 bells. His first duty is to see that all journals are running cool. This is done by feeling every working part of the engines. Starting with the cross heads and guides, he then goes to the lower platform and feels crankpins and main journals, then in the shaft alley, feeling thrust bearing and all the shaft journals. He also feels the tail shaft stuffing box and notices whether it is leaking excessively. There should be a slight leakage in order to lubricate the packing in this stuffing box.

He should also notice all auxiliary engines, such as circulating pumps, feed pumps if in engine rooms, electric light engines, steering engine if in engine room, sanitary pump, etc. He should see that all oil cups and cylinder lubricators are filled and a supply of oil for use during the watch is on hand. He looks in the bilges to see that there is not an excessive amount of water in them. He also notes whether water service is running through the journals.

In port, he assists the engineers in the overhauling of the engines. Many times he is entrusted with the job of overhauling the smaller units of the machinery, and he should be able to perform these duties. He should be able to take leads off a journal and see that it is in proper working condition. He must be able to overhaul all pumps and see that they are properly packed and valves in good condition and should be able to tell whether the valves require renewing. He should be familiar with the capacities of oil tanks and be able to compute their capacity.

An oiler can only learn by experience about the working conditions of journals. This alone will tell him whether a journal is showing excessive heat, and he should be able to tell when a journal is beginning to overheat in order that measures may be taken to prevent it becoming hot and melting out the metal in it. The amount of oil necessary to keep a journal working properly without using an excessive quantity, which is wasteful, varies with the conditions, such as size of journal, tightness of same, also temperature of engine room and quality of oil. A bright young man will soon learn this part of his duty.

An oiler should be able to do many of the mechanical jobs that are done aboard a ship with tools. He should know how to set up a ratchet and drill and drill a hole true and fair, also be able to grind the drills. He should learn how to use a hammer and chisel and file, in order that he may be able to do the many small jobs that are necessary to be done under the supervision of the engineers.

All renewals of joints and packing of valves are done by the oilers, and he should be able and willing to perform any duties he is called on to perform by his superior officers.

WATER TENDERS

A water tender has various and very important duties to perform aboard a ship. Usually he is a man who has served his apprenticeship as a coal passer and fireman, although frequently an oiler, who desires to learn the fireroom routine, asks for and obtains a watertender's position.

On going on watch, the water tender goes below at least 15 minutes before 8 bells. His first duty is to see that there is a proper amount of water in the boilers. He must blow out all the gauge glasses and try the gauge cocks by opening each one. A water tender cannot be too careful in performing this duty as it frequently happens that a gauge glass does not show the true level of water in the boiler by reason of the fact that it sometimes becomes stopped up. When this occurs, the glass is blown out by first shutting off the bottom valve and blowing through the top

valve, then opening the bottom valve, shutting off the top valve, and blowing through the bottom valve. This is done through the drain valve that is fitted to the bottom of the gauge glass.

On ascertaining the true water level in the boilers he should have a look at the fires that are to be cleaned to see that they are properly burned down. Then see that a sufficient supply of coal has been placed on the floor plates convenient to the fires, especially the ones that are to be cleaned. See that all ashes have been cleaned out of the ash pans, and out of the fire room. See that the bilges do not have an undue amount of water in them, that feed pumps are working properly. In fact, see that everything in the fire-rooms which he is to take charge of is in proper order, when he will relieve the water tender going off the watch.

During the watch he must maintain the proper water level in the boilers by manipulating the check valves on the boilers, opening the one on the boiler in which the water level is dropping, and closing the one on the boiler in which the water level is going up, frequently trying his gauge cocks to see that the glass is showing the true level.

He also has general supervision of the firemen and coal passers, seeing that they perform their duties properly, working the fires properly and in turn. See that the bilges are kept pumped out, all under the general supervision of the engineer in charge of the watch.

In port, he also has various duties to perform. He must see that tubes are swept, connections cleaned out, boilers cleaned internally and externally. He must also be familiar enough with the interior of a boiler to be able to detect any damage or weakness such as broken stays, furnaces coming down, interior feed pipes adrift, in fact anything wrong. It is also his duty to pack all valve stems that require it, such as main and auxiliary stop valves, feed check stop valves, and all other valves in the fire rooms. He also must be able to renew all joints on pipe lines where necessary, and he should have such a knowledge of the conditions in the fire rooms as to be able to tell when this work is necessary. If the feed pumps are placed in the fire rooms, as they sometimes are, it is his duty to overhaul same, examining valves, packing where necessary and be able to tell what repairs are necessary to them. He also should be able to grind in any valves on the boilers that require it, and should be able to tell when it is necessary.

He should also be familiar enough with the repairing of boilers to see that repairs are being done properly. If a tube should give out on watch he has to plug it. This is done in several ways. Sometimes a wooden plug is driven into the tube until it covers the leak. Another way is by use of patent tube stoppers, which are heavy rubber washers that just slip into the tube. Between these washers is a piece of pipe, and through washers and pipe is a rod threaded on each end and nuts on same. This arrangement is made up in various lengths and when a tube gives out a stopper is selected that will allow one washer to pass in beyond the leak, and the other enter in the front end of the tube. On tightening up the nut on the outer end of the rod, the washers are squeezed out against the tube, forming a water-tight joint. Sometimes it is necessary to cap the tubes. This is done by placing caps that fit over the ends of the tubes. These caps are made tight with red lead putty. A rod, with a nut on each end is run through the caps and tubes, and when nuts are screwed up the caps form a water-tight joint. To perform this operation the fires have to be drawn, pressure blown off the boilers, and a man has to enter the combustion chamber in order to place the cap on the back end.

MARINE BOILERS AND ACCESSORIES.

TYPES OF BOILERS.

A steam boiler has inside the outer shell, three principal parts: A place for the fire, a place for the water and metal surfaces separating them from each other.

The value of the boiler when in use, depends almost entirely upon the amount of fire-heated surface compared with the water contents of the boiler. Therefore it is good practice to make boilers with a series of tubes running from end to end of the heating section, in order to carry the heat through the water or the water through the heat.

The ideal condition exists in a boiler when no part of the water is very far from a fire-heated surface.

There are two general types of boiler: The **watertube** and the **firetube**. If the heat from the fire passes in tubes through the water the boiler is known as a **firetube** boiler and if the water passes in tubes through the heated area it is known as a **watertube** boiler.

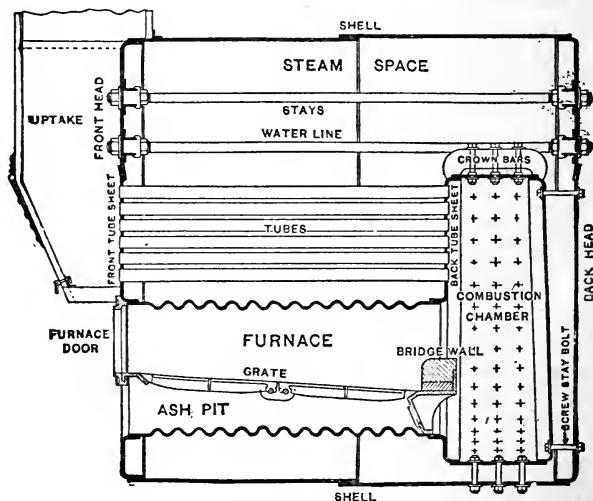

Fig. 9. Scotch Boiler

The return tubular or Scotch boiler is the type of firetube boiler generally used in marine work. A general idea of its internal arrangement is shown as Fig. 9.

Fig. 10 shows an end view of a three furnace firetube boiler.

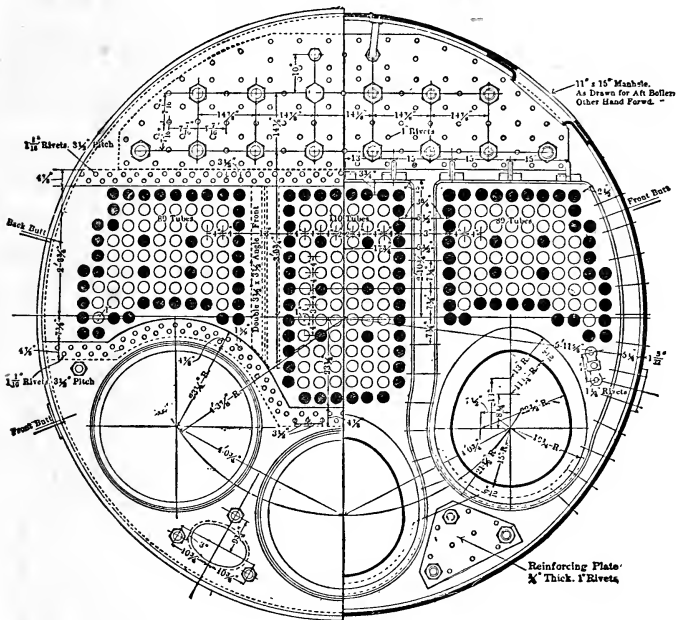
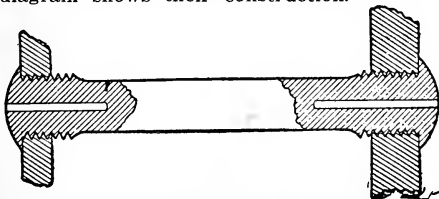

Fig. 10. Scotch Boiler, End View

Above the line of tubes showing on boiler front Fig. 10 will be noted several lines of six-sided or hexagonal nuts which are screwed on to the ends of reinforcing rods extending back to the combustion chamber. These are called screw stay-bolts and the following diagram shows their construction.



Improved Screw Stay

The latest regulations relative to the make of Stay Bolts are as follows:—

All screw stay bolts shall be drilled at the ends with a three-sixteenths-inch hole to at least a depth of one-half inch beyond the inside surface of the sheet. Stays through laps or butt straps may be drilled with larger hole to a depth so that the inner end of said larger hole shall not be nearer than the thickness of the boiler plates from the inner surface of the boiler. Hollow-rolled screw stay bolts may be used.

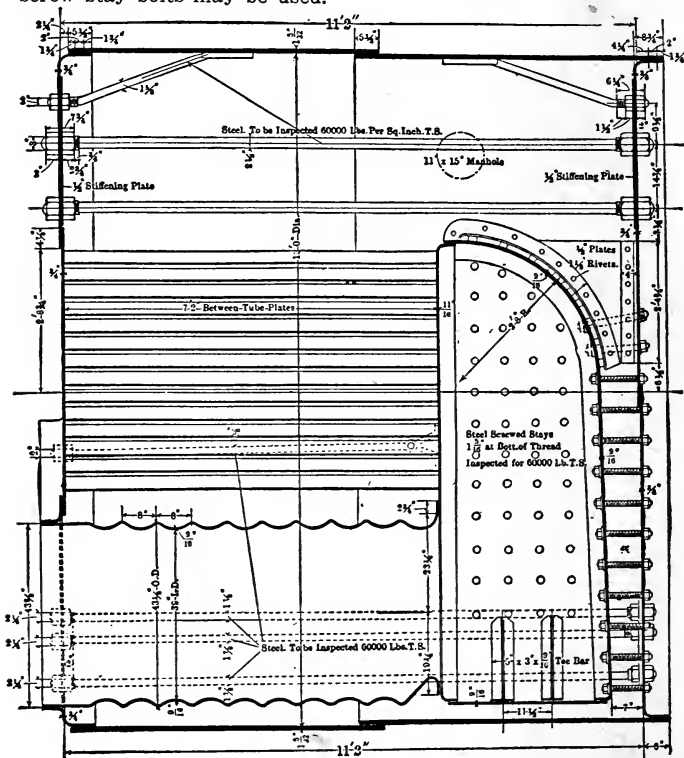

Fig. 11. Scotch Boiler, Longitudinal Section

Fig. 11 gives a sectional view of the modern type giving some detail of the construction of a Scotch boiler.

The type shown has furnaces at one end and is called a single-end with a combustion chamber at the back end. The double-end boiler has furnaces at both ends and the most satisfactory type has separate combustion chambers for each set of furnaces.

These boilers are cylindrical in shape and set horizontally, the heat and smoke from the fire passing from the fire-box, through the combustion chamber, returning through the tubes shown over the furnaces in Fig. 10 and passing through the up-take to the funnel.

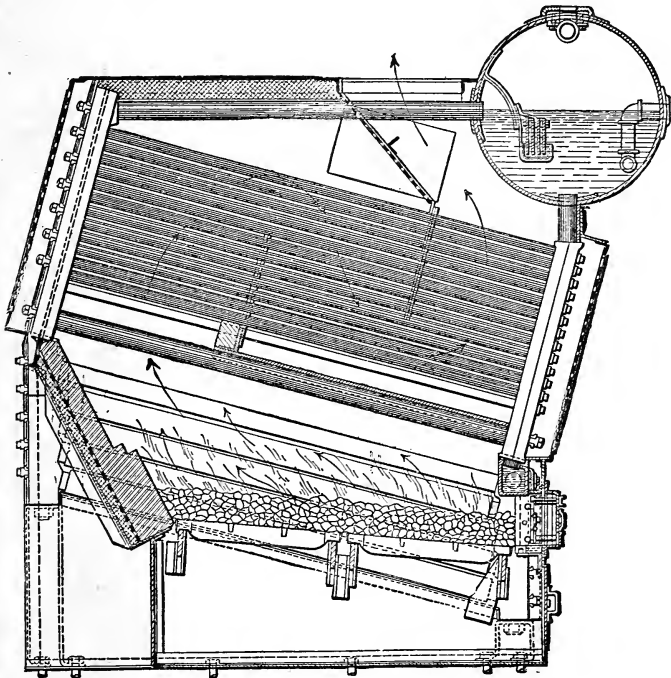

Fig. 25. One of the many Types of Coal Burning Watertube Boilers.

Merchant Vessels use firetube boilers almost to the exclusion of other types, while on the other hand the United States Navy uses watertube boilers to the same degree on account of their ability to generate horsepower readily under forced draft. A number of fast passenger steamers, known as "Ocean Greyhounds"

also use watertube boilers for the same reason. The diagram on the preceding page gives a good general idea of a modern watertube boiler.

Fresh-water feed is absolutely necessary for a watertube boiler and it is more difficult for the boiler-room force to operate a watertube boiler.

The peculiar "rake" or angle at which the tubes are placed in watertube boiler as shown in Fig. 25 is designed to speed up the circulation of the water.

SAFETY VALVES.

One of the most important of boiler fittings is the Safety Valve which is intended to allow the escape of confined pressure in the boiler when the pressure has mounted to the danger point.

Safety Valves are of two general types, lever and spring. The lever type has been generally abandoned because in some cases when valves have leaked or blown for some reason, extra weights were hung on the lever to keep the valve closed. The spring type, of which cuts are shown herewith, is the only one considered, and is not liable to be used in an objectionable manner.

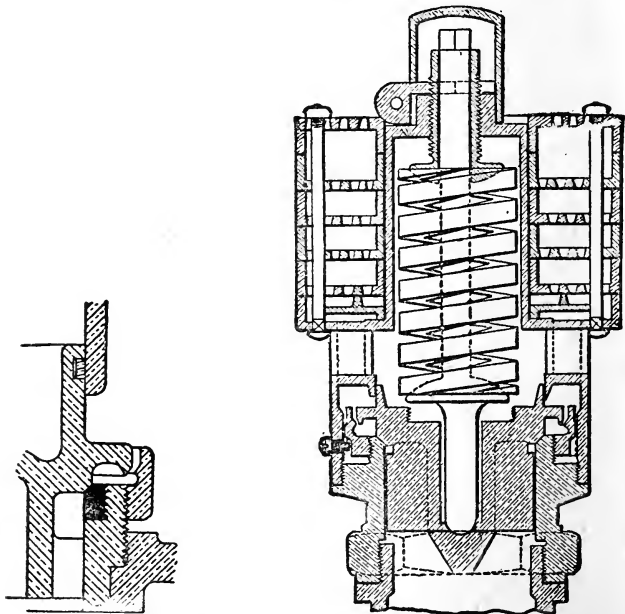

Enlarged Section of Lip

Safety Valve and Muffler

The operation of the valve depends upon the spring shown, which is set to open when the steam pressure reaches the danger point and when the pressure has been reduced to normal it closes automatically.

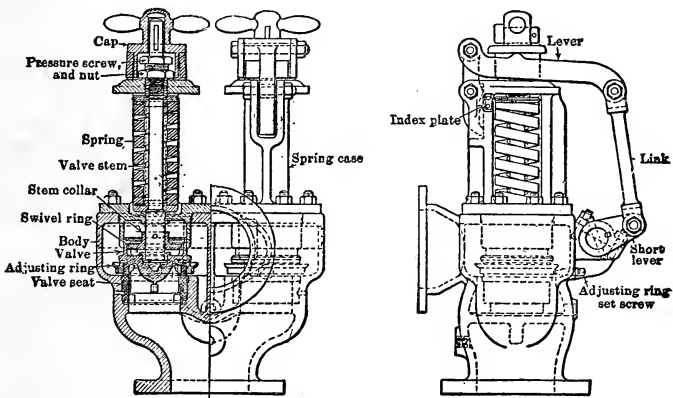

Duplex Safety Valve, showing Names of Parts

WATER GAUGE AND TEST COCKS.

There should be at all times while a boiler is in operation a sufficient amount of water in order to make steam, and the space above this water contains the steam reserve supply.

In order to know at all times just where the water line is in a boiler, a line of test cocks is placed vertically on the boiler front. To determine at a glance without opening a test cock where the water line is in the boiler, the water gauge as shown in the diagram is supplied.

Connected on a pipe column, which is joined to the boiler above and below the water line, the water level in the glass, on the principle that water finds its own level, shows the water level in the boiler.

Water gauge cocks are placed at top and bottom so that in case of breakage of glass the steam can be shut off. The modern gauge cock has a metal safety ball which rises automatically against a seat when the glass breaks and closes the opening.

At the bottom of the gauge glass is the pet-cock to drain the glass in order that it may be taken out and cleaned.

It is well not to depend on the water line as shown in the water gauge, but to test from the line of gauge cocks as well.

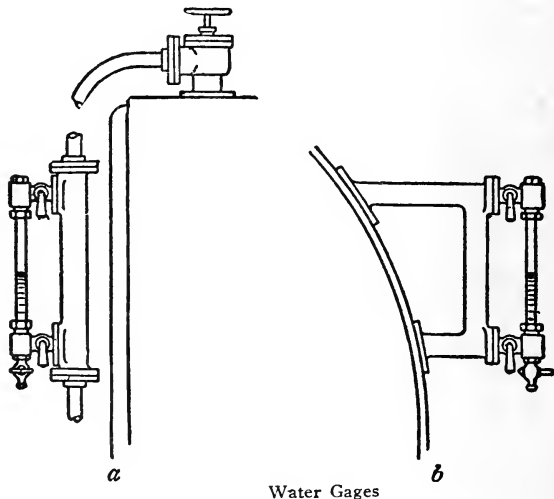

Water Gages

If the water does not show in the glass, test by means of the lowest gauge cock and if no water shows do not feed any in, but immediately draw the fire. This is very important.

STEAM GAUGE.

Indicated Steam Pressure shown on the steam gauge at the boiler front shows the excess over atmospheric pressure which is 14.7 pounds per sq. inch. The needle is therefore said to indicate steam pressure.

The diagram shows a section of the clock-like face of the gauge, and also of the working parts. The dip or "trap" in the pipe leading to the gauge fills with water and prevents the harmful action of live steam on the sensitive working parts of the gauge.

[Steam is an energy force, but if asked to define the word, just remember that "steam is an invisible gaseous fluid" not the white mist which you see, which is vapor, but the invisible something between the end of the open pipe and what most people call steam.]

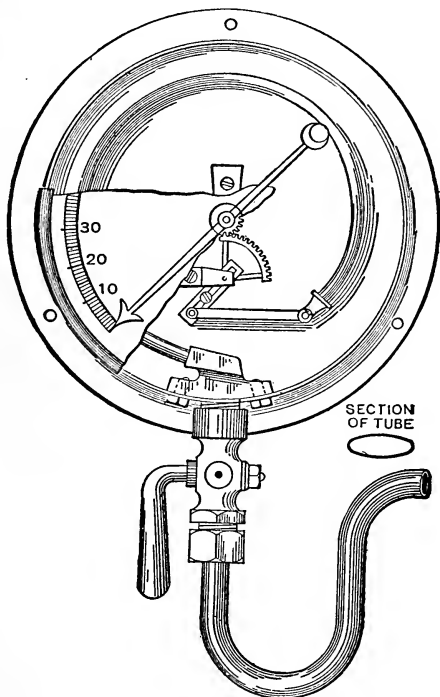

Bourdon Steam Gage

AUTOMATIC INJECTOR [Water-feed].

The water feed to boilers is pumped in by various means, among which is the device known as the Injector, which accomplishes what seems to be impossible. In operation the injector connected with the steam boiler overcomes the pressure and forces heated water into the boiler against a higher pressure than that under which the injector operates. The cut shown gives a good idea of the working parts.

The upper inlet marked, B, is connected with steampipe from boiler, the lower inlet also marked, B, connects with the water-tank or other supply. About a quarter-turn of the handle admits steam and starts water upward, the flow gradually increasing until a solid stream shows coming from the test pipe at bottom near feed pipe. A further turn of the handle closes the test pipe and forces

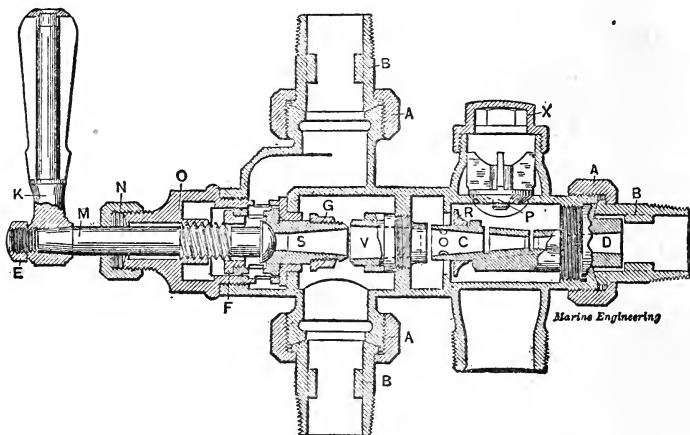

INJECTOR

the water through the opening D, and out of, B, at the extreme right, into the boiler. [The handle, K, when turned admits the steam through, S, and the steam forcing into, V, exhausts the air in the chamber, G. This causes the water to rise up in the chamber, B, and in turn the water is forced through into the passage, CD, and when the test pipe is closed, passes into the piping leading to the boiler.] The injector will start with about 25 or 30 pounds of steam and feed against any ordinary pressure in the boiler.

STOP VALVES.

At the point where the main steampipe leaves the boiler is located the main stop valve shown in the diagram.

This valve is used to shut off the steam from the system if desired and in cases where a series of boilers is arranged side

by side in battery formation, if it is desired to "cut-out" or discontinue for a time the use of a boiler this valve may be closed, the fire drawn and the boiler allowed to cool.

[Note. It may be well just here to say that if a cold boiler is being "cut-in" to a battery which is in use, care must be taken to open the stop valve slowly as the sudden jar caused in the heated boilers by rapid opening of this valve may cause an explosion.]

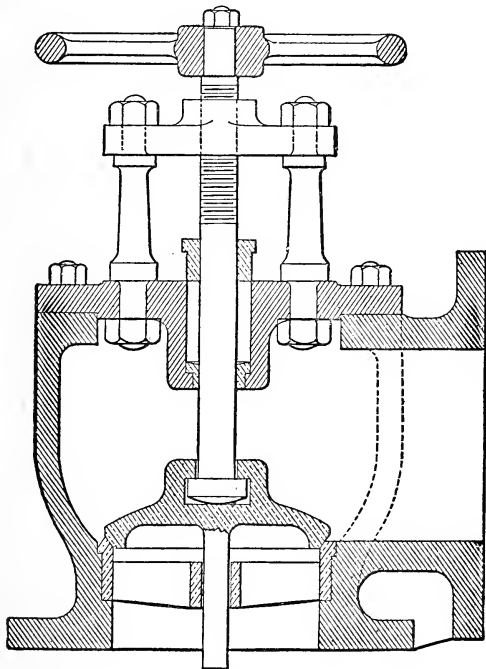

Boiler Main Stop Valve

Stop valves with large disc areas are sometimes equipped with a by-pass pipe of smaller size controlled by a valve which is opened gradually until the pressure is equalized and then the larger valve is opened wide and the by-pass closed.

CHECK VALVES.

Check valves are valves which close automatically against and automatically open with the pressure. In the diagram shown the inlet is at the bottom and the check or valve is shown seated. Water or steam pressure will raise the disc or "check" and pass by, but if the pressure is greater above the disc it will remain closed.

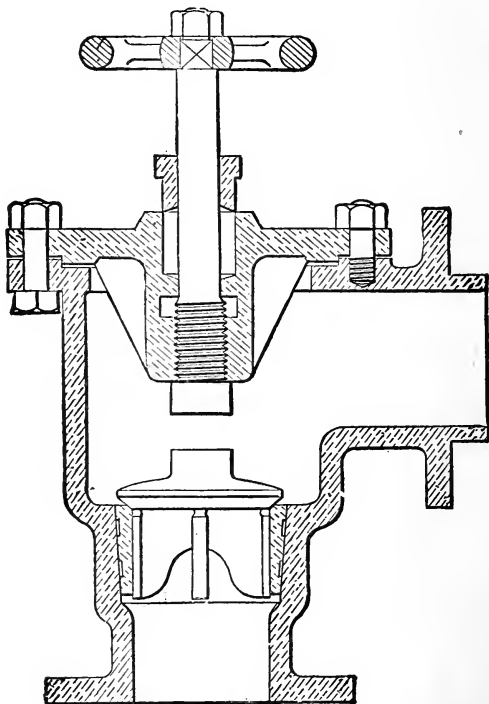

Boiler Check Valve

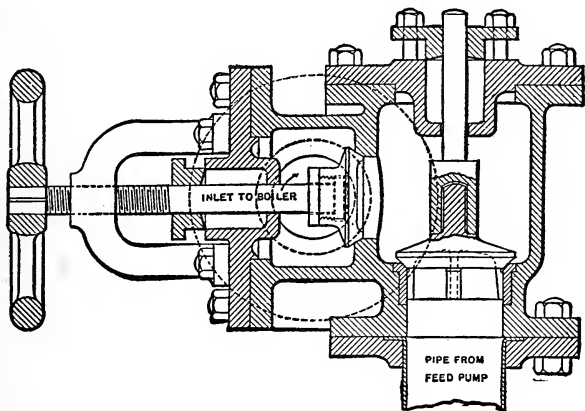

Combined Check and Stop Valve

FUSIBLE PLUGS.

A bronze casing, threaded on the outside, with a core tapering continuously and evenly from end to end and filled from end to end with tin that will fuse at low temperature, the larger end in every instance being in contact with the water and pressure from inside the boiler.

In fire box, Scotch and other types of shell boilers, two plugs are screwed in the crown sheet at the top of combustion chamber near the center and not more than 12" apart. Two kinds of plugs are used, called inside and outside plugs, the former being inserted from the inside of boiler and the latter from the combustion chamber side.

Fusible plugs are intended as a low water alarm, and are so placed that the larger end of the tin filling shall be at least 1" higher on the water side than the plate to which they are fitted. When the water drops below the plug, the tin filling is melted out by the heat of the fire, causing the escape of steam, which is a warning of low water.

Fusible plugs should be drawn and examined on both ends occasionally because sediment in the water often forms a deposit on the crown sheet covering the top of the plug, exposing it to the heat of the fire below with no protection from the water overhead. A hard scale, which is a non-conductor of heat, sometimes forms on the fire side of the fusible plug and prevents the melting of the tin in case of low water.

THE USE OF OIL FOR FUEL ON STEAM VESSELS.

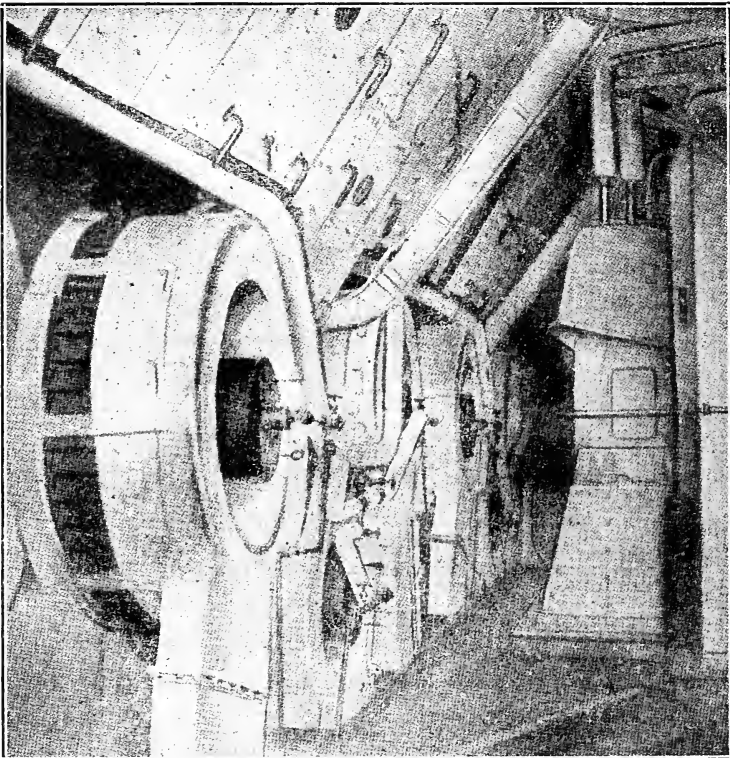

View of Fire Room Southern Pacific S. S. Co.'s Steamship "El Norte"

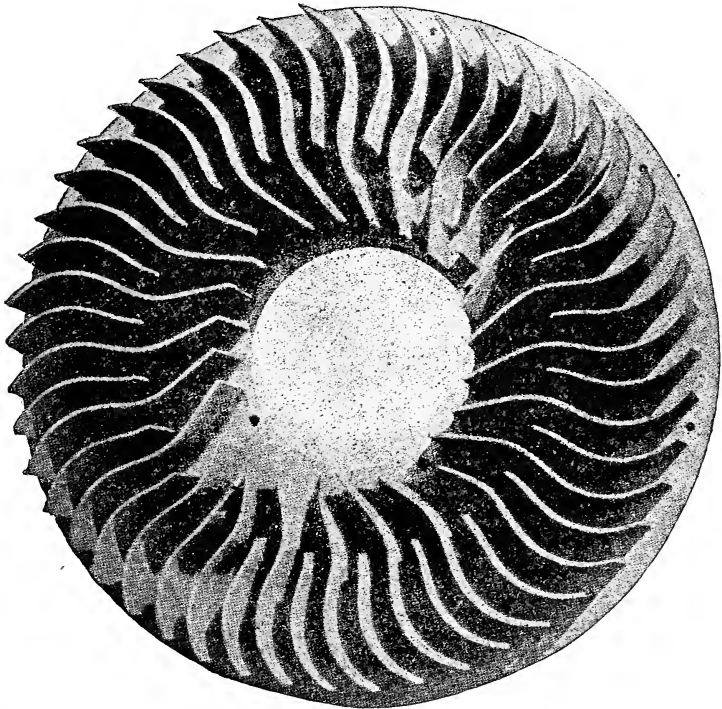

Section of Furnace Front showing Radial Vanes.

The use of oil fuel for marine purposes comprises essentially the burning of oil in the furnaces of steam boilers.

The oil is pumped aboard ship from a lighter or from a shore pipe-line, entering by one of the filling-pipe connections on either side of the ship, usually above the main deck. Thence it flows by gravity to the service tank or to the manifold, through which the oil is distributed to the storage or fuel tanks in the double-bottom of the ship.

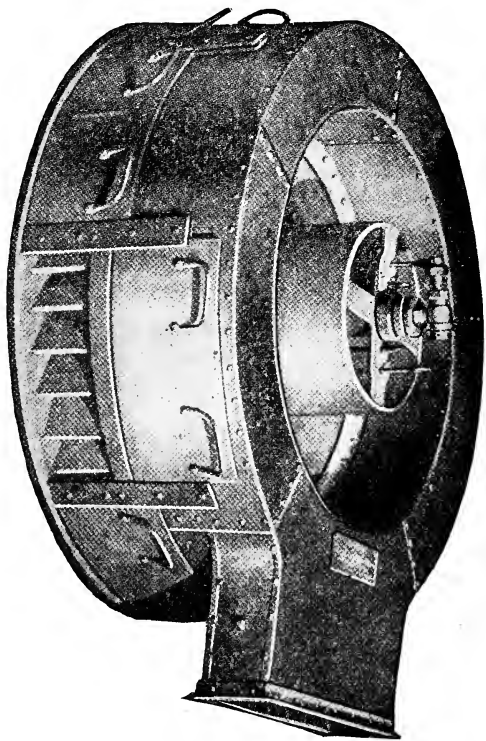

Forced Draft Furnace Front.

By means of the transfer or cargo pump and manifold the oil may be moved from any fuel tank to the service or settling tank, or vice versa, thus permitting any desired distribution to be effected by operating the proper valves. In most ships, the oil is transferred from the fuel or storage tanks to the service or settling tank, which is usually kept from half to three quarters full.

The oil is then drawn from this tank by the pressure pump through duplex strainers, on the discharge side of the pressure pump, the oil passing through another duplex strainer and thence through the heaters where its temperature is raised to between 150° and 275° F, depending upon the viscosity of the oil and the degree of heat necessary to render it fluid.

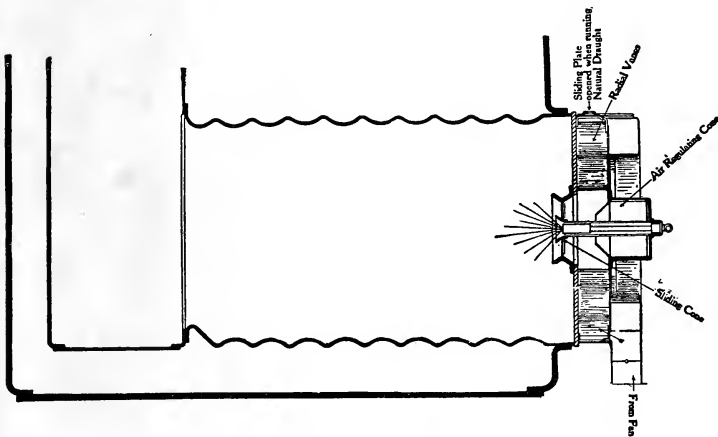

Arrangement of Furnace for Forced Draught.

After passing through the heaters at a pressure of about 90 lbs. the oil next passes through another duplex strainer to the oil feed line, thence to the burners.

On the end of the oil feed line a return line is usually fitted to allow the oil to circulate through the heaters or return to the service tank. The chief purpose of this is to afford a means of ensuring a supply of warmed oil when starting fires.

SETTLING TANKS

If the oil put aboard a vessel contains water in material amount, or if the double bottom tanks leak slightly and admit small quantities of sea water, then this oil is pumped out of the fuel tanks into the settling tanks where it is allowed to settle and the water drawn off from the bottom of tank.

In ships using oil as fuel the settling tanks are usually fitted so that while the fuel pump is taking oil from one tank the oil in the other will be settling and ready to be used as fuel when the first tank is emptied.

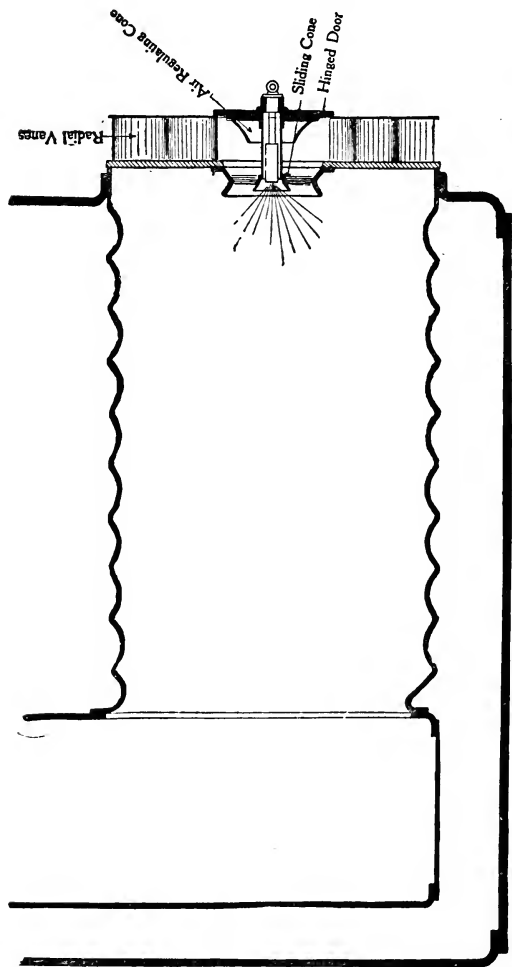

Arrangement of Furnace for Natural Draft

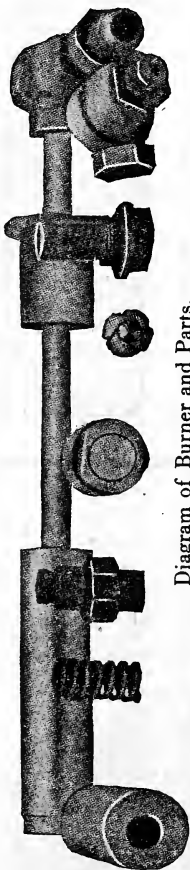

Diagram of Burner and Parts.

METHOD OF OPERATING

In case the ship is laid up with no steam or air available it will be necessary to have a hand force pump aboard connected to fuel tanks and oil feed line so that oil may be furnished to burner to raise steam on the boiler in order to operate fuel pumps.

Some ships are fitted with a Donkey boiler and a small quantity of coal to be used for just such an emergency.

A torch for lighting the burners is made of a hooked rod with either waste or asbestos wicking wrapped around the end and dipped in oil. Open all air ducts to give as much air as possible to the furnace, then open the oil valve on the burner slightly and insert the lighted torch through peep hole in furnace front and hold close in front of the burner until oil is ignited, then extinguish the torch and return it to its proper place.

The burner should be regulated with the proper amount of air and oil until the burner as viewed through the peep holes shows a bright white flame. Until the furnace is well heated an extra supply of air will be needed to prevent smoke. When the furnace becomes heated the air can be reduced to the desired quantity.

The other burners may be lighted as needed, first being sure that the air ducts are open. In case of vibration or drumming, shut off the burner until the blower is speeded up and sufficient air is obtained.

The best results will be obtained when a light gray smoke shows at the top of funnel.

THE BURNERS

The burners are generally of the mechanical atomizing type all of which operate on the same general principle.

The mechanism for atomizing consists of a cone shaped plug seating against the inner surface of the tip and held in position by a spring. The oil passes along grooves cut in the cone shaped plug, which are so arranged as to deliver the oil tangentially to the central chamber in the tip and at an angle of about 45 degrees.

This type of burner requires no controlling or needle valve to regulate the oil, the amount of fuel being regulated by the pump pressure. The tips are interchangeable and may be readily removed for cleaning and renewal.

HEATERS

The heaters are cylindrical in shape and have a single head containing stuffing boxes through which the ends of the heating coils pass. The coil ends are made oil tight by means of stuffing boxes and glands. All connections being outside, the possibility of oil leakage in the heater is eliminated.

The oil is heated for the purpose of reducing its viscosity to that requisite for rapid transit through the burner passages, and to allow of its issuing from the burner tip as a fine spray through the action of the centrifugal force imparted to it during its passage through the burner.

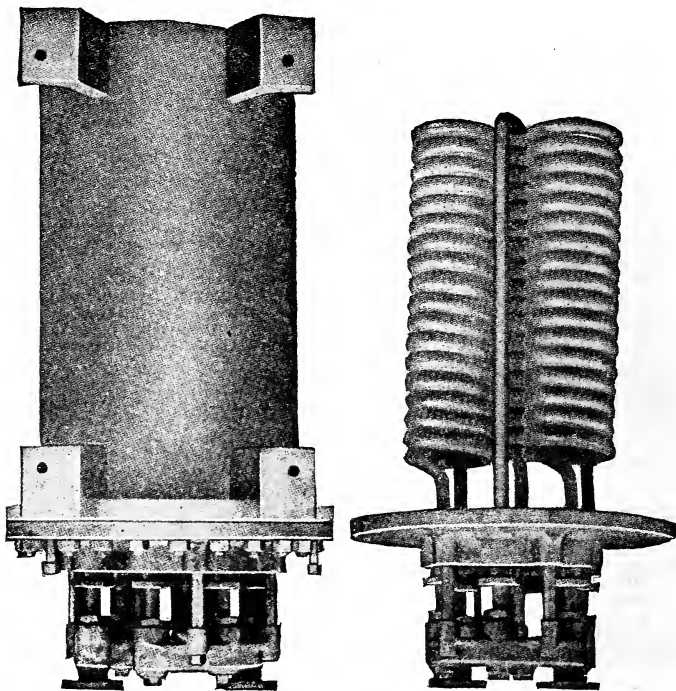

Heaters.

The desired temperature varies with different oils and depends on the relation its viscosity bears to its specific volume. As the different crude oils vary in density, the temperature and pressure can only be determined by actual burning of the oil under the varying conditions.

The steam used for heating purposes is generally the exhaust steam from fuel pumps or live steam direct from boiler. The drains for the steam condensed in the heaters lead to an inspection tank.

The inspection tanks are for the purpose of detecting any leakage of oil from the coils which might ultimately get into the boiler feed water.

STRAINERS

The fuel oil delivered from the oil wells holds in suspension fine particles of sand and grit. This is caught in the strainer baskets provided for that purpose in the line of flow between the tank and the burner.

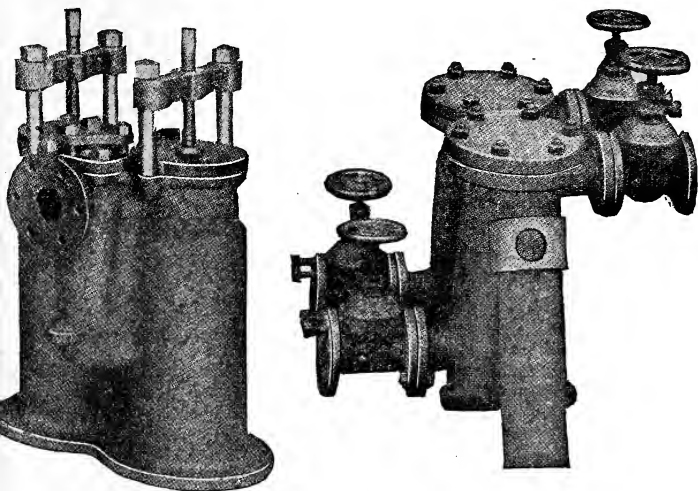

Strainers.

Usually two sets of duplex strainers are fitted. One set known as suction strainers are fitted in the suction line between the tank and the fuel service pump, and the other set, known as the discharge strainer, is fitted in the discharge line beyond the heater. These strainers are made duplex so that one strainer basket may be cleaned while the other is in service. The covers are made so as to be readily detached.

PRECAUTION AGAINST DANGER

The time has long passed when the use of oil fuel on ship-board was opposed on account of supposed insurmountable dangers. Oil has the distinct advantage over coal that it is not subject to spontaneous combustion, and many fires which have occurred in ship's bunkers at sea would not have been possible with oil for fuel.

Certain precautions, however, must be taken, such as suitable arrangements of vent pipes, protection of bulkheads if exposed to heat, and particularly the use of an oil with a reasonably high flash point. The flash point of oil is the temperature at which inflammable gas or vapor is given off.

Investigation has shown that oil is perfectly safe on board ship if the flash point is sufficiently above the temperature to which the oil may be exposed to prevent ignition or explosion. No trouble has been experienced in the safe storage and use of oil having a flash point of 150° F and upwards.

The firing or burning point is usually about 50° F above the flash point.

By giving careful attention to ventilation of the tanks and leading the vent pipes well away from all possible chance of exposure to flame, immunity from danger will be secured.

The burning point is the temperature at which sufficient vapor is given off to remain ignited.

Steam smothering pipes which are usually installed provide fairly effective means of extinguishing possible fires.

Other precautions are the fitting of pans under the furnace fronts of boilers to catch drippings of oil from the burners if they are to be removed for cleaning or renewal, and having a box filled with sand close at hand, ready to extinguish fires.

These precautions will probably prevent fires; but even then "eternal vigilance is the price of safety".

DANGER OF EXPLOSIONS.

The possible danger due to heating oil above the flash point, has been referred to, but there is always the chance that some careless or ignorant fireman may try to light a burner which has been atomizing oil and injecting it in the form of a spray into the furnace for some time previous to applying the torch. In this case it is quite possible that an explosion in the boiler furnace may occur, and for this reason, some engineers object to having dampers installed in the uptakes.

If the simple precaution is taken of always placing a lighted torch under the burner before turning on the oil, no possible danger of explosion in the furnace can exist.

Special precautions must be taken to prevent and to detect leakage from the tanks and to keep all naked lamps, fire, etc., at a safe distance.

BOILER ROOM AUXILIARIES.

FEED PUMPS, ETC.

The type of pump commonly used for feed pump purposes is shown in section on page 136 with parts numbered and is known as a "Simplex or single piston."

The pump is preferably placed on a level lower than its source of feed thereby keeping its cylinder full of water (or primed) at all times in order that any thrust of the piston rod will force water into the boiler.

The "Vertical Duplex" or double piston pump shown on page 134 is also used in many cases for feed pump purposes and the same type, with reversed areas of steam and water pistons, for bilge or other pump work.

The term duplex means that the pistons operate alternately and the piston rod of each pump operates the valves of the other.

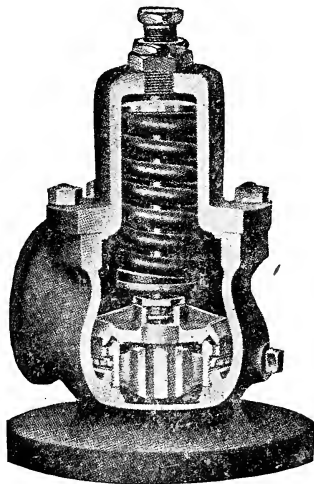

RELIEF VALVE.

As shown in cut this valve is generally made with an iron body containing a seat covered by a disc which is pressed upon by a phosphor bronze spring. This spring is adjusted by the set-screw, shown at top, to maintain a pressure upon the lower seat slightly in excess of pressure normally created by pump.

When the pressure becomes greater in pipe line than that for which spring has been set, the valve operates by compression of the spring, thus relieving the excess pressure.

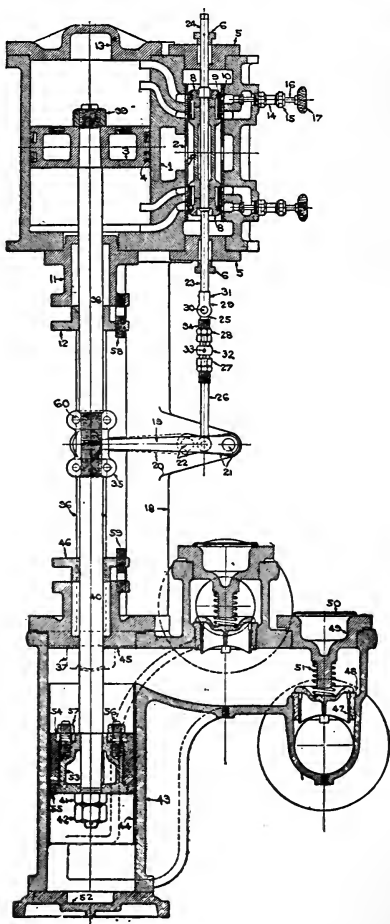

Type of Vertical Duplex Pump Commonly Used.

LIST OF PARTS OF VERTICAL DUPLEX PUMP.

No.	NAME OF PARTS.	No.	NAME OF PARTS.
1	Steam Cylinder.	31	Taper Pin.
2	Steam Chest Lining.	32	Tappet.
3	Steam Piston.	33	Tappet Pin.
4	Rings.	34	Sleeve.
5	Valve Rod Stuffing Box.	35	Crosshead.
6	Gland.	36	Tie Rods.
7	Piston Valve.	37	Tie Rods Nut.
8	Follower.	38	Steam Piston Rod.
9	Inner Ring.	39	Steam Piston Rod Nut.
10	Outer Ring.	40	Pump Piston Rod.
11	Steam Cylinder Stuffing Box.	41	Pump Piston Rod Nut.
12	Gland.	42	Pump Piston Rod Lock Nut.
13	Upper Steam Head.	43	Pump Cylinder.
14	Cushion Valve Box.	44	Lining.
15	Cap.	45	Upper Pump Head.
16	Stem.	46	Gland.
17	Handwheel.	47	Pump Valves.
18	Tie Piece Pedestal.	48	Valve Seat.
19	Long Lever.	49	Valve Cover.
20	Short Lever.	50	Cover Plate.
21	Long Crank and Shaft.	51	Spring.
22	Short Crank and Shaft.	52	Pump Base.
23	Valve Rod.	53	Pump Piston.
24	Tail Rod.	54	Follower.
25	Short Connections.	55	Ring.
26	Long Connections.	56	Follower Studs.
27	Nut.	57	Follower Stud Nuts.
28	Check Nut.	58	Gland Studs (Steam Cyl. Stuff. Box).
29	Knuckle.	59	Gland Studs (Upper Pump Head).
30	Knuckle Pin.	60	Crosshead Studs.

FEED WATER HEATER.

In order to avoid loss of steam pressure which would be caused if cold water was injected or pumped into the boiler, an appliance is used which is called the feed water heater.

The cold water is fed into this heater and steam, (usually exhaust), is forced through it until the water has almost reached 212 degrees Fahrenheit, which is the boiling point. This water is then supplied to the boiler either by the injector or feed pump.

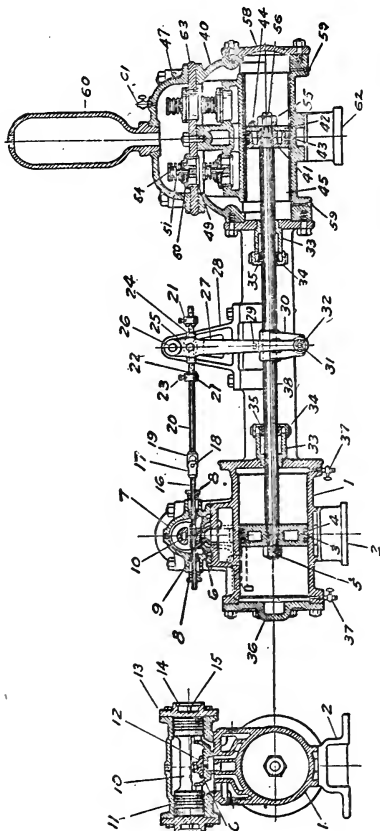

Type of Plunger Pump Commonly Used for Feed Pump Purposes with List of Parts.

1. Steam Cylinder and Centerpiece	30. Crosshead	47. Pump Cap
2. Steam Cylinder Foot	31. Lever Pin	48. Valve Seat
3. Steam Piston Rings	32. Piston Rod Stuffing Box	49. Valve
4. Steam Piston Nut (Steam)	33. Stuffing Box Cap	50. Valve Backing for rubber valve
5. Main Slide Valve	34. Steam Cylinder Gland	50-A. (not shown)
6. Auxiliary Cylinder	35. Steam Cylinder Head	51. Valve Spring
7. Valve Rod Gland	36. Piston Rod	52. Valve Bolt
8. Auxiliary Cylinder Stuffing Box	37. Piston Rod Collar Split Nut	53. Piston Rod Nut (Pump)
9. Auxiliary Plunger Rings	38. Valve Rod Collar Set Screw	54. Split Pin
10. Auxiliary Plunger Rings	39. Tappet Pin	55. Outside Pump Head
11. Auxiliary Slide Valve	40. Pump Cylinder	56. Drain Plug
12. Auxiliary Cylinder Head	41. Pump Follower	57. Air Chamber
13. Name Plate	42. Piston Follower	58. Air Cock
	43. Piston Backing	59. Pump Cylinder Foot
	44. Piston Follower Stud	60. Valve Plate
	45. Pump Cylinder Lining	61. Valve Plate
	46. Piston Follower Stud	62. Valve Plate
	47. Pump Cap	63. Valve Plate
	48. Valve Seat	
	49. Valve	
	50. Valve Backing for rubber valve	
	50-A. (not shown)	
	51. Valve Spring	
	52. Valve Bolt	
	53. Piston Rod Nut (Pump)	
	54. Split Pin	
	55. Outside Pump Head	
	56. Drain Plug	
	57. Air Chamber	
	58. Air Cock	
	59. Pump Cylinder Foot	
	60. Valve Plate	
	61. Valve Plate	
	62. Valve Plate	
	63. Valve Plate	

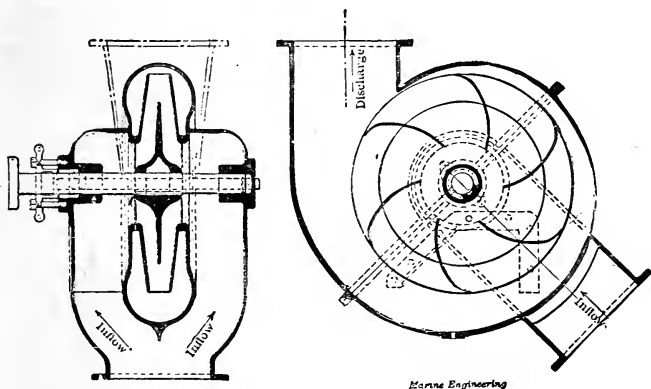

CIRCULATING PUMP.

Centrifugal Type.

CIRCULATING PUMP.

The purpose of the circulating pump is to draw from overboard, the water used in the condenser, force it through the condenser tubes and return it overboard again.

The diagram shown is what is known as the "centrifugal" pump and is the style generally used for this purpose. The inflow (or suction) pipe passes up, turns with an elbow and enters the case where the black circle is shown in the center of the radiating fans of the centrifugal.

The pump in operation with its rapidly revolving shaft and attached blades thrusts the water up through the "discharge" pipe and on to the condenser. This type of pump will deliver large quantities of water if the "head" or resistance is not great.

CONDENSERS.

Condensers are used to convert exhaust steam back again into water to be again used for feed water purposes.

The type shown is what is known as a "surface condenser" consisting of a cylindrical water-tight tank with a middle chamber and two separate end chambers. A system of small tubes extends from one end chamber to the other and when sea-water is pumped into one end it passes through the tubes to the other end and then returns through the tubing system and is discharged overboard.

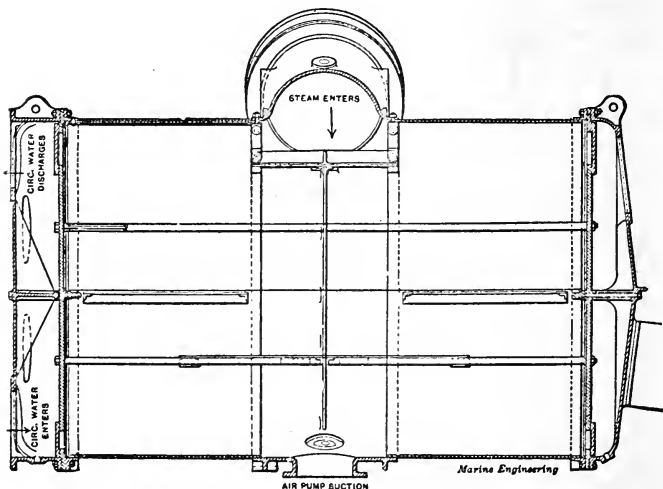

SURFACE CONDENSER.

Longitudinal Section.

The exhaust steam enters at the top of the middle chamber, sprays over the tubes and again becomes water for further use. The smaller the diameter of the tubes and the greater their number, the more rapid the operation of the condenser.

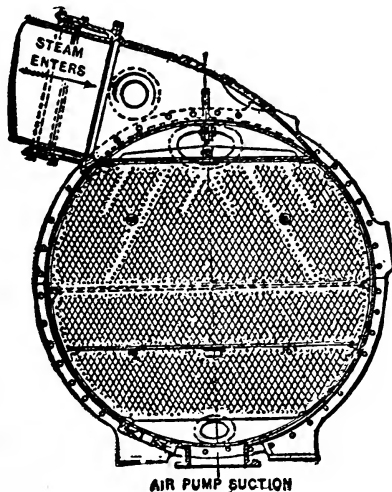

SURFACE CONDENSER.

Cross Section, Showing Tubes.

AIR PUMP.

The Air Pump is designed to remove from the condenser the water formed from exhaust steam and also such air as may have formed in the system and been passed along to the condenser.

The air pump takes its feed from the bottom of the condenser and when the plunger of the pump is lowered the cylinder fills through the valves in the bottom of the plunger. When the plunger is raised the air and water together are raised to the top of the pump whence the air passes off and the water is passed to the hot well and returned to the boiler by the feed pump.

Air pumps are sometimes operated directly by attachment to the main engine shaft but the type shown, which is generally used, is known as the "Vertical Single Acting Twin Beam" and is not so attached.

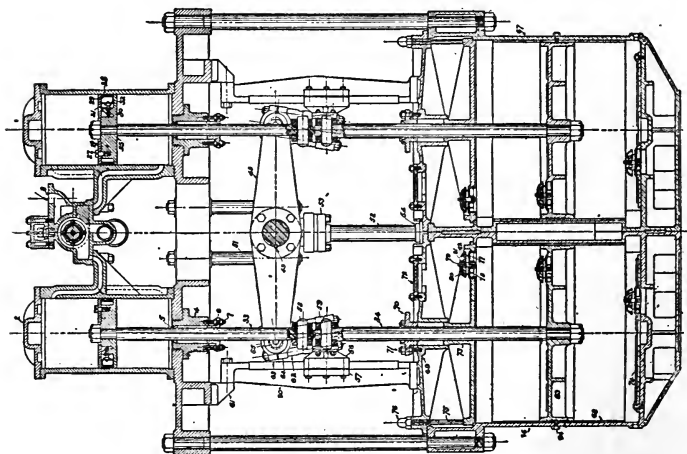
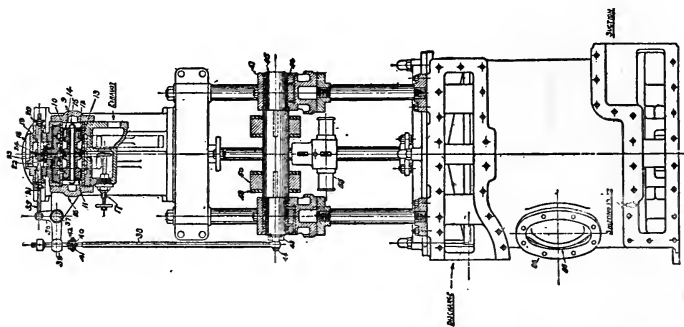

DIAGRAM OF PARTS FOR VERTICAL SINGLE ACTING
TWIN BEAM AIR PUMPS

LIST OF PARTS FOR VERTICAL SINGLE ACTING TWIN BEAM AIR PUMPS.

No.	Name of Part	No.	Name of Part
1	Steam Cylinder.	46	Beam Pedestal.
2	Upper Steam Cylinder Head.	47	Beam Pedestal Cap.
3	Entablature.	48	Beam Slab.
4	Steam Piston Rod Stuffing Box.	49	Beam Slab Key.
5	St. Pist Rod Box Throat Bushing.	50	Beam Slab Distance Piece.
6	Steam Piston-Rod Gland.	51	Upper Supporting Rod.
7	St. Pist Rod Gland Stud and Nut.	52	Lower Supporting Rod.
8	Steam Chest.	53	Upper Supporting Flange.
9	Steam Chest Back Bonnet.	54	Lower Supporting Flange.
10	Steam Chest Lining.	55	Crosshead.
11	Steam Chest Piston Valve.	56	Crosshead Slide.
12	Piston Valve Ring, outer.	57	Crosshead Slide Cap.
13	Piston Valve Ring, inner.	58	Crosshead Wedge, Steam End.
14	Piston Valve Follower.	59	Crosshead Wedge, Pump End.
15	Piston Valve Bolt, Complete.	60	Crosshead Guide.
16	Steam Chest Front Bonnet.	61	Crosshead Guide Bracket.
17	Exhaust Throttle Valve Complete.	62	Beam Link.
18	Auxiliary Steam Chest.	63	Beam Link, Upper Box.
19	Valve Rod Box Throat Bushing.	64	Beam Link, Lower Box.
20	Valve Rod Gland.	65	Beam Link Bearing Pin Complete.
21	Valve Rod Gland Stud and Nut.	66	Pump Cylinder, Left Hand.
22	Auxiliary Steam Chest Slide Valve.	67	Pump Cylinder, Right Hand.
23	Valve Rod Nut.	68	Pump Cylinder Lining.
24	Valve Rod Nut Taper Pin.	69	Upper Pump Cylinder Head.
25	Steam Piston.	70	Pump Piston Rod Gland.
26	Steam Piston Follower.	71	Pump Piston Rod Gland Stud and Nut.
27	Steam Piston Follower Bolt.	72	Upper Pump Cylinder Head Handhole Plate.
28	Steam Piston Ring, outer.	73	Head Valve Plate.
29	Steam Piston Ring, inner.	74	Foot Valve Plate.
30	Steam Piston Set-Out Bolt.	75	Head Valve Plate Holding Bolt.
31	Steam Piston Set-Out Check Nut.	76	Head Valve Plate Bolt Cap Nut.
32	Steam Piston Spring.	77	Pump Valve Disc.
33	Steam Piston Rod.	78	Pump Valve Seat.
34	Pump Piston Rod.	79	Pump Valve Bolt.
35	Valve Rod.	80	Pump Valve Spring Guard.
36	Bell Crank Lever.	81	Pump Valve Spring Guard Nut.
37	Bell Crank Lever Pin Complete.	82	Pump Valve Spring.
38	Valve-Rod Link.	83	Pump Bucket.
39	Valve Rod Link Tappet.	84	Pump Cylinder Lining Stud.
40	Valve Rod Split Nut.	85	Pump Cylinder Handhole Plug.
41	Valve Rod Collar.	86	Pump Cyl. Handhole Guard Ring.
42	Valve Rod Collar Set Screw.	87	Tie Rod (No. not shown in diagram).
43	Driving Crank.		
44	Driving Crank Pin Complete.		
45	Beam Shaft.		

EVAPORATOR.

The evaporator is designed to supply fresh water in sufficient quantity to make up the loss of feed water by leakage of steam, etc., or when steam is used for other purposes and the exhaust is not returned through the feed. This loss often amounts to more than five per cent. but must be made up and this is done by the use of sea water.

A modern evaporator such as is here shown consists of coils of pipe enclosed within a case or chamber.

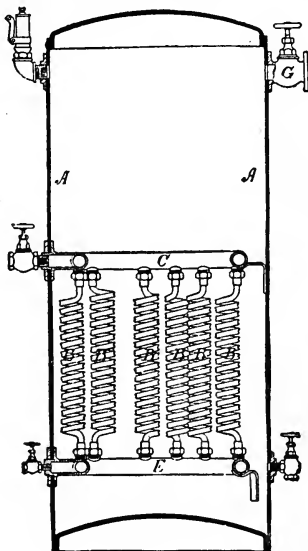

Interior Arrangement of Evaporator, Showing Tube Coils.

The sea water enters the chamber and the steam passing through the pipe coil heats the water to the vapor point. This vapor then passes on to the condenser after having (in the case of salt water) left the salt in the evaporator and becomes part of the feed water reserve.

Evaporator tubes become crusted with deposit on the outside and may be readily removed for cleaning from time to time.

MARINE ENGINES FOR MERCHANT SERVICE.

RECIPROCATING ENGINE.

There are several types of Marine engines generally used aboard Merchant Steamers, the most important of which is probably what is known as the "Reciprocating" engine.

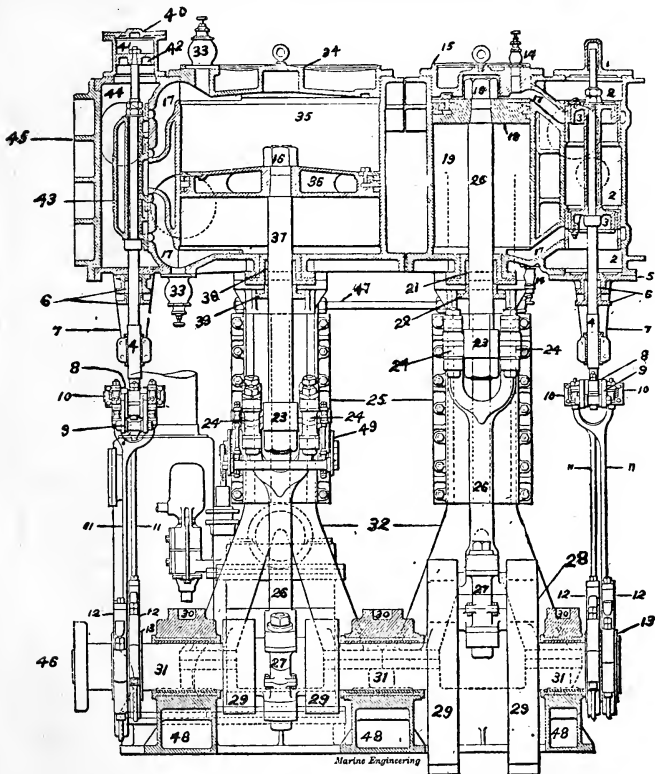

Longitudinal Section, Compound Marine Engine.

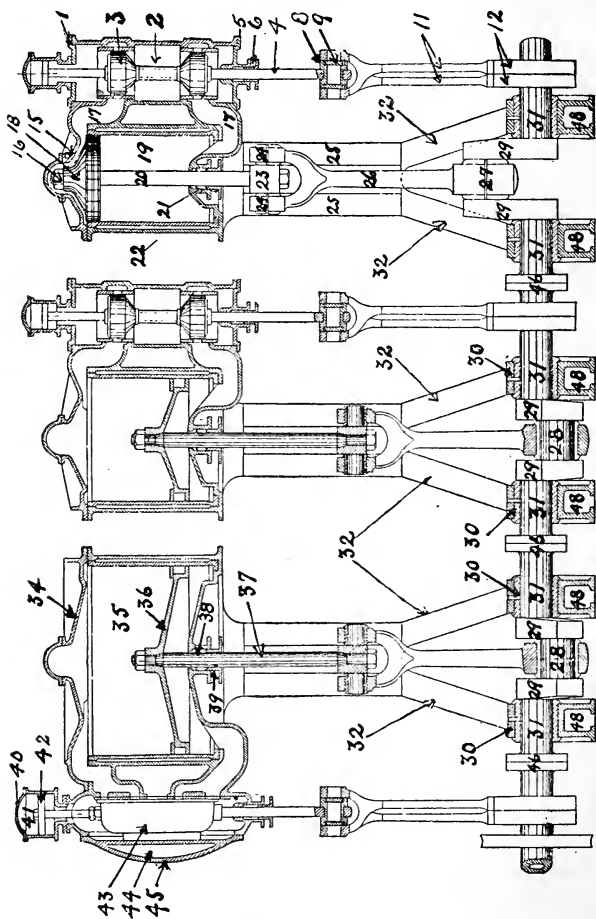

Longitudinal Section, Triple Expansion Engine.

NAMES OF PARTS

INDICATED BY NUMBERS ON DIAGRAMS OF
RECIPROCATING ENGINES, Pages 143-144.

1. H. P. Valve Chest Cover (top).
2. H. P. Valve Chest.
3. H. P. Piston Valve.
4. Valve Stem.
5. H. P. Valve Chest Cover (Bottom).
6. Valve Stem Stuffing Box & Gland.
7. Valve Stem Bracket & Guide.
8. Link Block.
9. Links.
10. Drag Links or Bridle Rods.
11. Eccentric Rods.
12. Eccentric Straps.
13. Eccentrics or Sheaves.
14. H. P. Cylinder Relief Valves.
15. H. P. Cylinder Cover.
16. Piston Rod Nut.
17. Steam Ports.
18. H. P. Piston (consisting of Follower, Bolts, Bull Ring & Packing Rings).
19. H. P. Cylinder.
20. H. P. Piston Rod.
21. H. P. Piston Rod Stuffing Box.
22. H. P. Piston Rod Gland.
23. Crosshead.
24. Crosshead Brasses.
25. Guides (in which Crosshead Slippers Run).
26. Connecting Rods.
27. Crankpin Brasses.
28. Crankpin.
29. Crank Webs.
30. Main Bearing Caps.
31. Main Bearings.
32. Cylinder Columns.
33. L. P. Cylinder Relief Valves.
34. L. P. Cylinder Cover.
35. L. P. Cylinder.
36. L. P. Piston (consisting of Follower, Bolts, Bull Ring & Packing Rings).
37. L. P. Piston Rod.
38. L. P. Piston Rod Stuffing Box.
39. L. P. Piston Rod Gland.
40. L. P. Balance Piston Cover.
41. L. P. Balance Piston Cylinder.
42. L. P. Balance Piston.
43. L. P. Double Ported Slide Valve.
44. L. P. Valve Chest.
45. L. P. Valve Chest Cover.
46. Shaft Coupling.
47. Column Tie Rod.
48. Engine Bed.
49. Air Pump Lever.

Reciprocating Engines are of several classes which are individually known as "Compound" the term applied to an engine with two cylinders, "Triple Expansion" if of three cylinders, "Quadruple Expansion" if of four cylinders, and all the classes mentioned are styled in general "Multiple Expansion" on account of the cylinders through which the steam operates being two or more in number.

The illustration on page 143 is a longitudinal section view of what is known as a compound engine of the Merchant Type, the parts being numbered for identification by the description given in the table shown on page 145.

A "Triple Expansion" engine is also shown in longitudinal section and the numbers on this drawing indicate similar parts to the numbers shown on the section view of the compound engine.

The engine shown operates in an upright or vertical position and the thrust of the piston also is vertical, the reverse of old type engines, therefore this type is designated as vertical, inverted, direct acting, multiple expansion, condensing engine.

In the modern engine the exhaust steam passes into a condenser thus giving the advantage of increased ratio of expansion and decreased back pressure. This explains the term **condensing**.

The motion of this engine is carried through the piston, piston rod, crosshead, connecting rod, crank pin and crank shaft and for this reason the term **direct acting** is used.

TURBINE MARINE ENGINES.

The Turbine or "rotary" engine is coming into more general use each year and installations are being made from time to time aboard merchant vessels. The latest development in the Turbine is the satisfactory equipment of the engine with geared drive direct from the shaft. Turbine engines are of two general types, the "Low Pressure" and the "High Pressure" and in some cases both types are included in the same installation with cross-connections permitting the use of either engine as desired.

The general principle on which the turbine operates is by rigidly mounting a system of blades, end on, to the circumference of the shaft of the engine, enclosing the shaft and blades within a casing to which steam is admitted, striking the blades and "impelling" or pushing the blades away from the steam pressure, thereby causing the shaft to revolve. Generally speaking, the operation is the exact reverse of the ordinary electric fan used to make air currents in the Summer time.

Manufacturers of Turbine engines claim their product is superior to the reciprocating engine on account of being easier to handle, requiring less space to install, being more immediately responsive to applied power and smoother in operation. It is admitted that a turbine will operate at high speed with less shock to the other sections of the unit than will any other engine developing the same power.

Manufacturers of turbine engines claim a saving of about one-third in dead weight of machine, over the ordinary reciprocating engine.

The great objection made to turbine engines is that at low speeds, they are wasteful of steam.

REDUCTION GEARS.

SHAFTS OF TURBINE ENGINES revolve at high speed and in order to adapt the speed to the slower moving propeller shaft of the vessel, use is made of what are called Reduction Gears which are simply cog-wheels of different sizes which engage together and transmit the power at reduced speed.

With the turbine shaft revolving at 3600 revolutions per minute the first reduction gear brings this down to 450 revolutions per minute and the second reduction gear brings this down still further to 70 revolutions per minute which is about the normal speed developed by the shaft of a "Parsons" turbine. The gear wheels are made of cast-iron with a steel rim or casing and are mounted on a heavy forged steel shaft and operate as it were in an oil bath.

The features mentioned, together with the condenser and circulating pumps which operate along similar lines to those that form parts of other steam power installations, give a general idea of the operation of a turbine steam engine.

GLANDS AND PACKING.

THE GLANDS AND PACKING which prevent steam leakage from one to the other of the cylinders or chambers of the engine are very important parts of the equipment of a turbine engine and these appliances are shown in considerable detail in the diagrams which follow. All parts of the engine where water is liable to collect are equipped with drain pipes to a steam ejector which pumps this water into the condenser.

THE SPEED OF THE ENGINE is automatically controlled by what is called the "governor" which is set for a certain speed and should this speed be exceeded the governor partially closes the steam supply and reduces the speed of the engine.

LUBRICATION.

Lubrication of gear teeth and bearings plays an important part in the operation of the turbine. The "Parsons" is fitted with a "gravity" tank* set overhead from which oil flows over the gears and bearings, wasting into a tank below from which it is returned by pumps connected to the shaft of the engine, filtered, cooled and returned to the engine. The oil supply to the bearings enters at the bottom and flows to the top and thence to the tank below.

*Every 27 inches in elevation of tank gives one pound pressure.

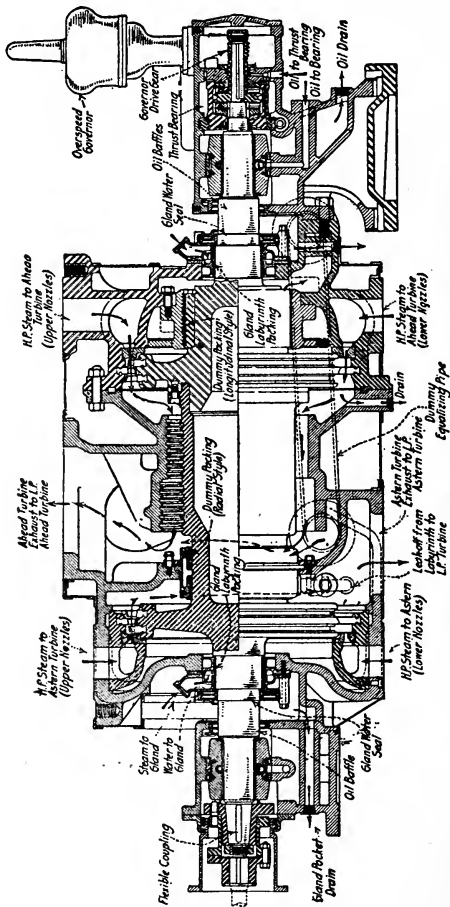

Cross Section of "Parsons" High Pressure Turbine Engine.

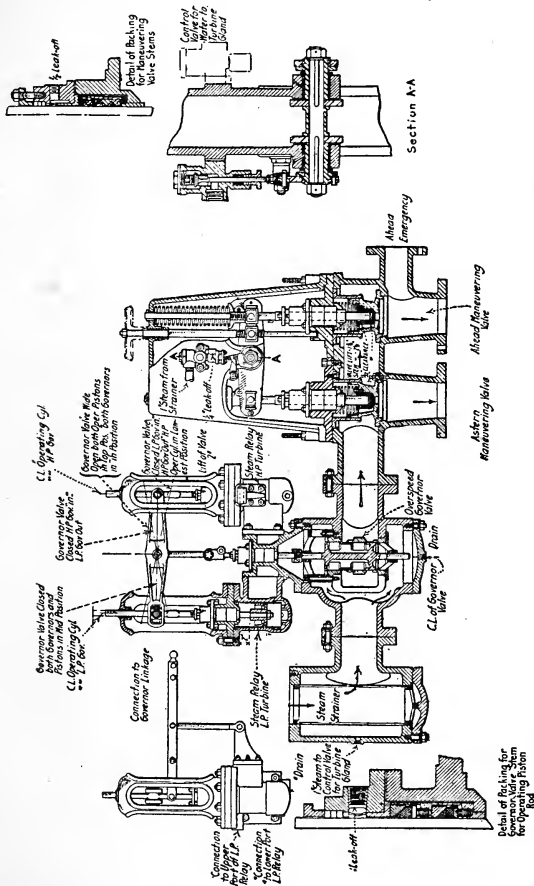

Section Through Steam Strainer, Governor and Maneuvering Valves.
Parsons High Pressure Turbine.

The above diagram gives a view of important operating parts and also of the hand controls.

The diagram that follows gives a good general idea of the arrangement and location of all the appliances and connections placed in some modern vessels built for and used in the oil carrying trade.

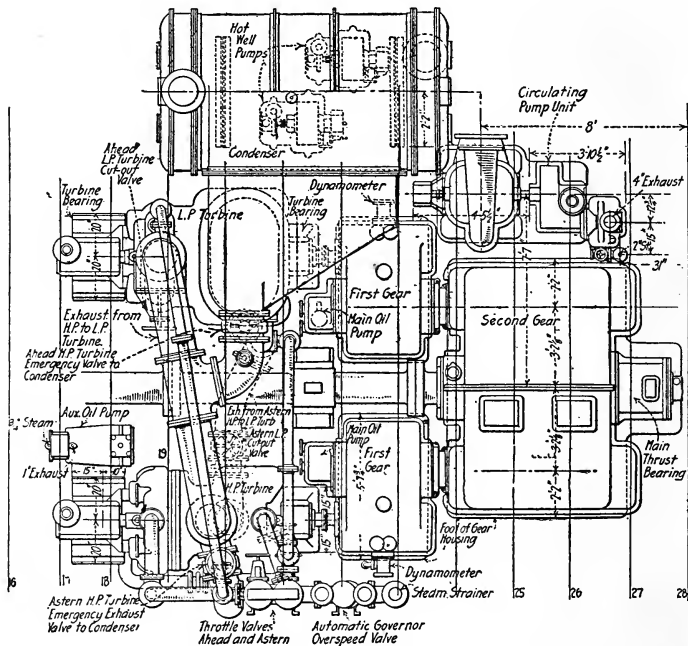

Plan of Engine Room

Showing Location and Arrangement of Turbines, etc.

PLAN OF ENGINE ROOM.

The turbines here shown are of the "Parsons" combined impulse reaction cross-compound type and fitted with both "Ahead" and "Astern" features.

The sectional views of the "Parsons" high pressure turbine shown on the two preceding pages give at a glance an idea of the interior arrangement and the proportion of the various parts, many of which are identified by name.

DESCRIPTION OF GENERAL ELECTRIC MARINE GEARED TURBINE.

TURBINE.

The turbine is so arranged that the ahead turbine and the reversing turbines are carried on the one shaft and in the same casing and consists of five stages for the forward turbine and two stages for the reversing unit. The maneuvering is done by hand and is interlocked in such a manner that it is impossible to open the valve for the astern turbine, if the valve for the forward turbine is not closed, or vice versa. The first wheels of the forward and the reversing turbines each carry a double row of buckets, the remaining wheels carrying a single row of blading.

All wheels are of forged steel with the rims machined to receive the buckets which have a dovetail shaped root of the same shape as the rim.

The intermediate segment for the first stage forward buckets is bolted to the first stage nozzle and the turbine head and the stationary buckets for the first stage reverse are dovetailed into the holder which is cast integral with the second stage nozzle diaphragm, the flange of which is bolted to the turbine shell.

The first stage forward nozzle segment is bolted to the upper half of the turbine head. The first stage nozzle ring for the reversing turbine is made in halves and bolted to the turbine shell, shoulders being turned on the nozzle which fits grooves turned in the inner flange of the turbine shell.

The second stage, forward nozzle ring consists of four flanged segments, the inner flange having a projection which rests in a ledge turned in the second stage nozzle diaphragm; the outer flange being bolted to the diaphragm.

SPEED REDUCING GEAR.

The speed reducing gear which is mounted directly abaft the turbine is of the laminated or Alquist flexible disc double reduction type, provided with helically cut teeth which are designed to equalize the driving pressure over the active driving face and limit the strain imposed at any one point.

The shafts of the pinions and gears are each carried by bearings mounted in the gear casing, which is split horizontally to provide accessibility to the enclosed parts.

The teeth of the pinions are cut integral with their shafts; the high speed pinion being connected to the turbine by a flexible coupling.

The discs of the flexible gears are keyed and pressed on their shafts in two sections against a collar which separates the two. Studs having nuts setting in counterbored holes pass through the discs and the collars and prevent axial movement at these points.

In handling, care should be taken to see that nothing comes in contact with the teeth, discs, or shafts, which might in any way injure them. In assembling, the gears and casings should be scrupulously clean and free from all lint, dirt and grit. Kerosene should be used as a cleansing medium and thoroughly wiped dry to prevent rusting. The bolts in the flanges of casing sections should be drawn up snug.

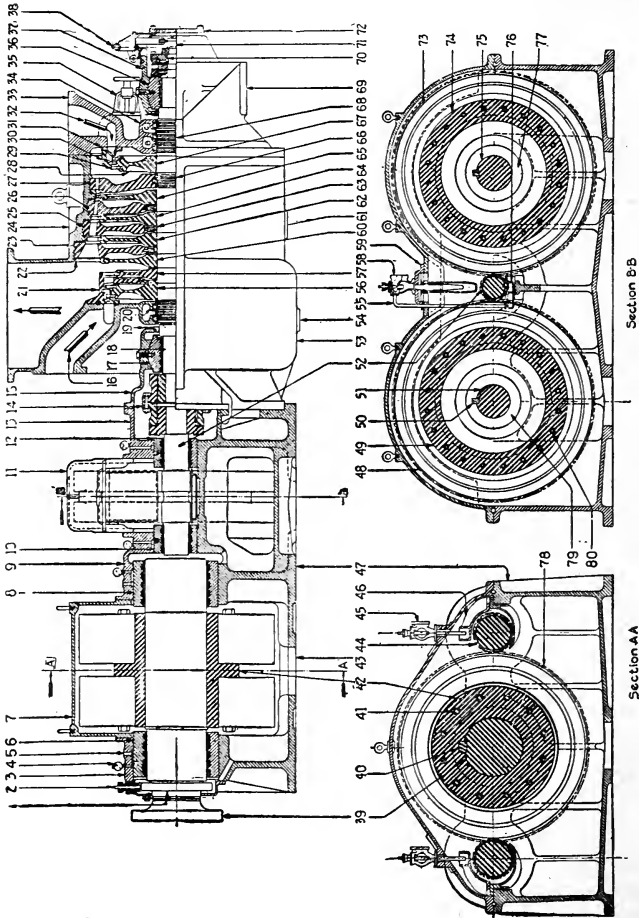

Longitudinal Section (Top) Cross Section Through Gears (Bottom)
General Electric Marine Geared Turbine

SECTION THROUGH TURBINE AND GEARS.

1. Rail for 2 halves pinned to low speed gear shaft.
2. Propeller shaft speed counting device.
3. Bearing cap 6.
4. Oil pressure gauge.
5. Connection for oil feed to bearing.
6. After bearing—low speed gear shaft.
7. After gear casing—upper.
8. Forward bearing—low speed gear shaft.
9. Bearing cap for 8 and 10.
10. After bearing—high speed pinion shaft.
11. Forward gear casing—upper.
12. Forward bearing. High speed pinion shaft.
13. Bearing cap for 12.
14. Flexible jaw coupling with bolts and nuts
15. Bearing cap for 17.
16. Steam inlet—astern turbine.
17. Turbine bearing—exhaust end.
18. Turbine shaft.
19. Oil and air deflectors.
20. Labyrinth type shaft packing—after.
21. Intermediate segment and nozzle diaphragm with packing and retaining rings.
22. Cover for buckets—Quote number of wheel.
23. Fourth forward nozzle diaphragm complete with packing and retaining rings.
24. Turbine shell—upper.
25. Third forward nozzle diaphragm complete with packing and retaining rings.
26. Second forward nozzle diaphragm complete with packing and retaining rings.
27. First forward nozzle diaphragm with packing rings.
28. First stage forward wheel.
29. Bucket—Quote number of wheel.
30. Intermediate bucket segment.
31. Nozzle—Quote whether for forward or astern turbine.
32. Steam inlet—forward turbine.
33. Turbine head—upper.
34. Labyrinth type shaft packing—forward.
35. Hand valve for further controlling steam to first stage nozzles.
36. Turbine bearing—forward.

37. Cap for 37 and 69.
38. Emergency tripping device.
39. Low speed gear shaft.
40. Key for 39 and 42.
41. Bolt and nuts for 42 and 77.
42. Flanged collar.
43. Oil discharge from gear casing.
44. Low speed pinion—port or starboard.
45. Sight feed lubricator for low speed pinion.
46. Oil nozzle or distributor—port or starboard.
47. Gear casing—lower.
48. High speed gear—port.
49. Sleeve for 48 and 79.
50. Key for 51 and 79.
51. Shaft for 49.
52. High speed pinion.
53. Turbine shell—lower.
54. Connection from chamber B and for live sealing steam for 20.
55. Oil supply pipe for 76.
56. First stage astern wheel.
57. Second stage astern wheel.
58. Sight feed lubricator for high speed pinion.
59. Flange for 58.
60. Fifth stage forward wheel.
61. Connection for pipe leading from packing chamber.
62. Fourth stage forward wheel.
63. Spacing sleeve—Quote number of wheels.
64. Third stage forward wheel.
65. Second stage forward wheel.
66. Packing sleeve—first diaphragm.
67. First stage forward wheel.
68. Packing sleeve for 18 and 34.
69. Turbine head—lower and bearing standard.
70. Turbine thrust bearing.
71. Emergency governor.
72. Cover with studs and nuts for 37 and 69.
73. High speed gear—starboard.
74. Sleeve for 73 and 77.
75. Shaft for 77.
76. Oil nozzle for 52.
77. Coupling—starboard.
78. Low speed gear.
79. Coupling—port.
80. Bolt and nuts for 48 and 49.

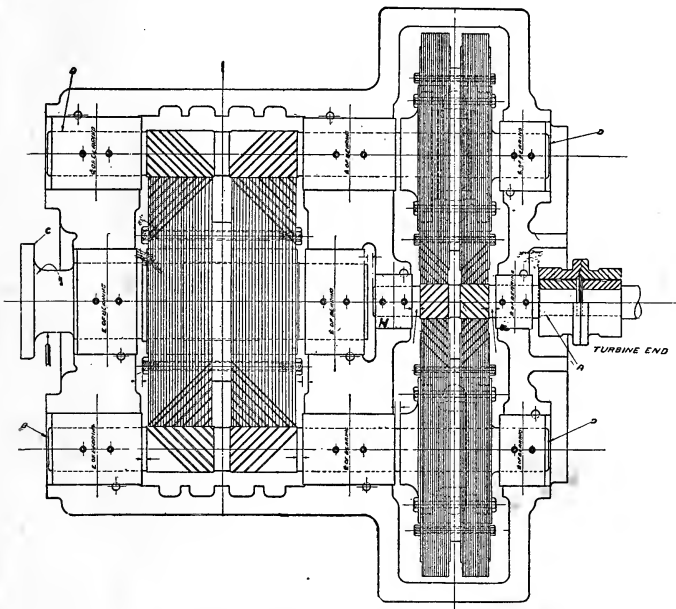

Arrangement of Gears, Shafts and Bearings
General Electric Marine Geared Turbine.

Fore and aft location of the gears and pinions in the casing is fixed by the position of the main thrust shaft.

Clearances must be maintained by the adjustment of the main thrust bearing.

Movement of the main thrust can be detected at the indicator "H," on the low speed shaft. The arrows indicate direction of rotation when going forward.

- A—High speed pinion.
- B—Intermediate speed pinion.
- C—Low speed shaft.
- D—Stub shaft.

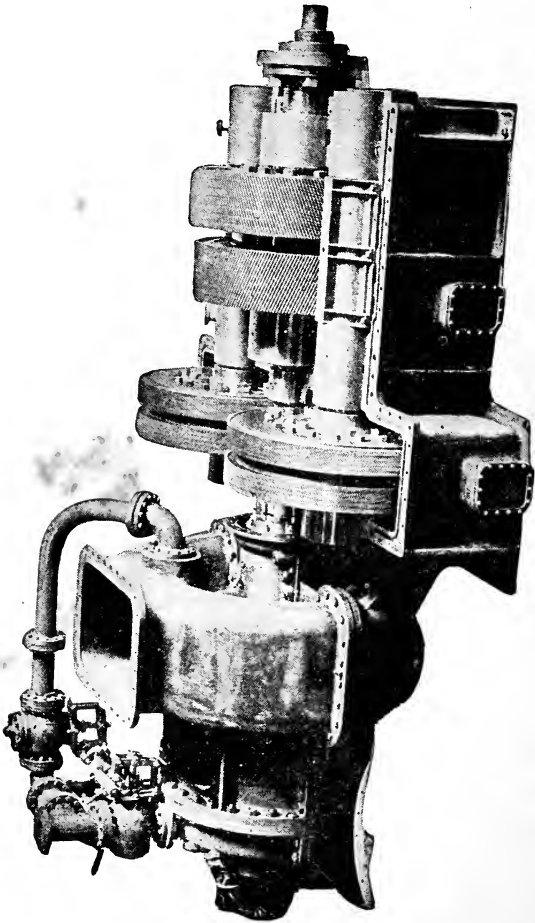

Reduction Gears of General Electric Marine Geared Turbine.
Top half of Gear Casing removed.

ARRANGEMENT OF SHAFT PACKINGS.

To take care of steam leakage around the turbine shaft where it passes through the wheel casing, labyrinth type packings are employed. In many of the earlier turbines the rotating rings were turned on the shaft, as shown in the illustration, but in later designs the revolving rings are pressed on the shaft and pinned to prevent their displacement. The stationary packing rings are in halves and are secured to the turbine head and the shell and have a radial clearance of approximately 0.005 inch. The steam leakage from the high pressure shaft packing is used to seal the low pressure packing. Any excess steam from the high pressure packing is fed into the fourth stage bowl of the forward turbine and the valve in the pipe from Chamber A should be adjusted to avoid an excessive amount of steam about the packing. When starting the turbine, and while running at low speeds, it may be necessary to admit live steam to seal the packings.

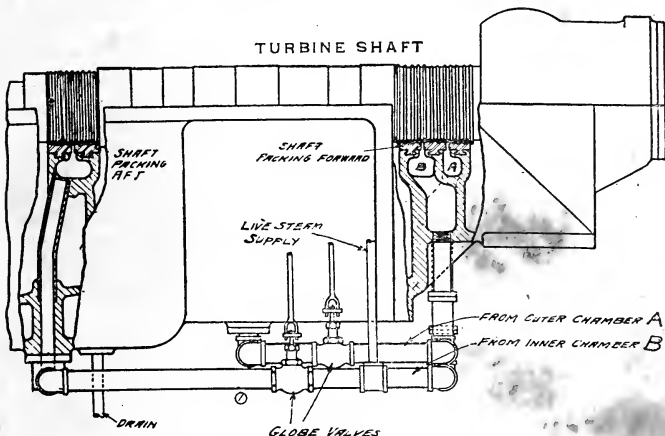

Shaft Packing and Steam Seal Piping.

Impairment of the vacuum will be avoided by properly sealing the shaft packings.

A change in speed and consequent variation in the load and steam pressure, demand immediate adjustment of the valves for the steam seal in order to maintain efficient operation of the unit.

INSTRUCTIONS FOR THE CARE AND OPERATION OF THE GENERAL ELECTRIC MARINE GEARED TURBINE.

The following instructions are necessarily brief, and further information may be had upon application to the Ship Propulsion Division of the Turbine Engineering Department, General Electric Company, Schenectady, New York.

BEFORE STARTING THE TURBINE.

1. All oil tanks must be provided with pure, clean oil.
2. Examine the oil strainers for foreign substances.
3. The steam strainer which forms a part of the emergency valve must be cleaned to avoid loss in initial steam pressure.
4. The auxiliaries must be placed in the best of working condition.

STARTING THE TURBINE.

1. See that the oil pump is furnishing an ample supply of good, clean oil to the various bearings, thrusts and gears.
2. Make certain that the oil gauges are registering properly.
3. See that the maneuvering valve is closed.
4. Open the drains from the steam pipe and valves leading to the turbine.
5. Open the header or boiler stop valve slowly, to allow the pipe to heat up and the condensate to escape through the drain pipes.
6. When the steam pipe is hot the drain valves should be closed.
7. Adjust the steam supply to the shaft packings by means of the valves furnished therefor.
8. Note if the main condenser and auxiliaries are functioning properly.
9. Close the hand valves in the upper half of the turbine head.
10. Make certain that the turbine shell is at all times free from water accumulations to avoid a loss in efficiency and damage to the rotating parts.
11. Open the "ahead" maneuvering valve to allow the turbine to start revolving and to warm up.
12. Inspect the clearance indicator and the propeller shaft speed counting device.
13. After the turbine has started to revolve, trip the emergency valve by hand several times to make sure that the tripping devices and the valves are in working order. If these are found to work satisfactorily the speed may be brought to normal.
14. Make any needed adjustments to the oil supply to the bearings, thrusts and gears.
15. Inspect the steam and vacuum joints for leakage and re-adjust the valves in the steam seal to the shaft packings.
16. Examine the "astern" maneuvering valve, also the guarding valve which is placed between the astern maneuvering valve and the steam inlet for the astern turbine, to make certain that they are closed tightly when not in use.

TO DISASSEMBLE THE TURBINE.

The head, shell and diaphragms are split horizontally to allow easy removal of the diaphragms, wheels, packings and shaft.

1. Make certain that all bolts and nuts are disengaged in the parts to be removed before lifting.
2. Do not attempt to lift the upper half of the turbine shell without having the guide pins properly placed and made tight.
3. Use care in handling to prevent damage to the various parts, especially the teeth of the shaft packings, buckets, diaphragms, shafts and bearings.
4. Avoid damage to all steam joint surfaces thereby preventing the forming of burrs and ridges.

BEARINGS.

1. The bearing clearances must not at any time exceed 0.002 inch, per inch diameter of the journal. As this maximum clearance is approached the bearings should be re-babbitted. In as-

certaining the clearances, the actual diameters of the journals should be obtained rather than using the dimensions given on the drawings.

2. In re-babbitting the bearings allow 0.001 inch per diametrical inch of the journal, e. g., when re-boring a bearing with a journal diameter of eight inches, the bearing should be bored and carefully scraped to a diameter of 8.008 inches.

3. A re-babbitting diagram blue print for the turbine and the gear bearings is furnished with each installation, and in re-babbitting, groove the bearings exactly as shown and in scraping the babbitt avoid the forming of ridges.

4. Avoid damage to the bearing surfaces of the thrust rings and journals. Use only the smoothest oil stone and kerosene if attempting to restore the polished surfaces.

5. Before reassembling the bearings, carefully wipe away all grit, scrapings, lint, waste, or other foreign matter liable to damage the bearings or to stop the oil circulation.

6. The bearings for supporting the flexible coupling must be set to give the most accurate possible alignment as to centering and direction while running. The turbine rotor and the high-speed pinion shaft are initially assembled in exact alignment and must be so maintained.

7. The jaw bearing strips of the flexible jaw coupling must be kept tight by the securing screws and ample lubrication provided to the bearing surfaces to prevent excessive wear and clearance. Should it become necessary to renew the bearing strips, use a good tough quality of bronze or bearing metal such as is used in the making of engine brasses.

8. The gears and the turbine are carefully balanced before shipment from the factory, and to avoid undue wear on the bearings the rotors as well as the propeller of the ship should be kept in as good a balance as possible.

9. Do not unmesh the gears when renewing the bearings, as the lower halves can be revolved out of position by slightly raising the shafts.

10. Under no circumstances should the turbine or gear bearings be machined at the joints. When the clearance is excessive the shells should be re-babbitted.

SEATINGS.

1. The seatings for the gear casing and the propeller thrust casing should be tied together and independent fore and aft movements absolutely prevented.

2. Where the casings have to be drilled and tapped, use care not to drill through the casings and into the oil chamber.

3. Should any unusual condition arise, such as a collision, that would tend to alter the original setting, the seatings should be carefully examined and the alignment checked to avoid damage to the gears, shafts, packings, wheels, etc.

4. From time to time the operating engineer should examine all bolts and nuts to make sure that they have not worked loose owing to the working of the ship or to temperature changes.

CAUTION.

TO AVOID POSSIBILITIES OF EXPLOSIONS, FLAMING LIGHTS SHOULD BE KEPT AWAY FROM THE GEAR CASE OPENINGS WHILE THE OIL IS HOT AND VAPOROUS.

LUBRICATION.

THE OIL MUST BE KEPT CLEAN.

1. Maintain a reserve supply of oil for emergencies.
2. Use a pure mineral, hydro-carbon oil, having a viscosity of approximately 260 seconds at 100 deg. F. (Saybolt viscosimeter). Avoid oils containing acids, thickeners and tarry, slimy or saponifiable matter.
3. The oil must not readily form an emulsion when in contact with water.
4. Maintain a line pressure of from 12 to 15 lb. gauge on the oil supply pipes to the gears and bearings. Make certain that the pressure gauges are registering properly and that ample lubrication is being supplied.
5. All pressure gauges should be throttled sufficiently to reduce needle vibration and consequent wear on the internal mechanism.
6. Be sure that the oil nozzles are properly adjusted to allow the required flow of oil.
7. The oil tank level alarm gauges must be kept in good working order.
8. Do not allow salt or other water to mix with the oil.
9. Test the oil cooler periodically for water leaks.
10. Do not allow sediment to collect in the oil pipes, gear casings, or drain tanks.
11. Take a sample of oil from the return pipe once a week to determine the amount of water and sediment carried in suspension.
12. The oil supply pipes to the pumps should be connected several inches above the bottom of the drain tank so as to draw only clean oil. The oil pump must be installed with the oil cylinders below the level of the oil in the tanks and the supply should be continuous. Air pockets in the oil feed will cause an intermittent flow of oil and injury to thrusts, gears, and bearings.
13. Do not allow the oil pump to "race."
14. A stop cock or other device must be provided at the lowest point in the tank to drain away any accumulation of water.
15. All oil tanks should be provided with suitable clean-outs for removing sediment and other foreign matter. Clean regularly. The oil pumps, coolers, strainers, and filters must be maintained in an efficient condition of operation to supply good, clean oil. A steady increase in the oil temperature, with a normal operating condition of the auxiliaries, indicates oil fatigue and make-up oil should be immediately added, all foreign matter removed from the tanks and the used oil filtered.
16. The working oil temperature should approximate 160 deg. F. Should there be a tendency to greatly exceed this, due to operation in the tropics, the depth of the grooves in the upper halves of the turbine bearing can be increased to allow a larger oil flow and greater cooling effect.
17. The low-speed gear must not dip in oil due to the oil being allowed to back up in the gear casing, because the friction thus established will cause not only undue heating of the oil and casing, but a great loss of power.
18. Any foreign matter in the oil carries with it a certain portion of hard particles. This grit carried in suspension in the oil acts as an abrasive and will result in the rapid deterioration and reduced life of the gears.
19. Do not use waste or other linty substances on oil covered surfaces. Use wiping cloths and, to avoid accident, wipe only when the apparatus is not running. Use Kerosene only. Do not use gasoline.

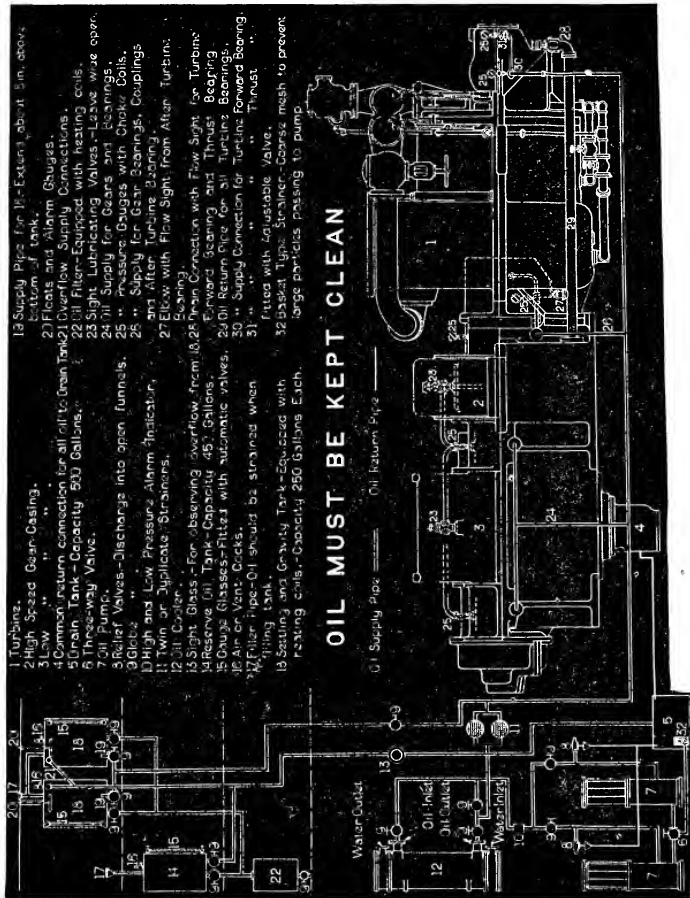

Diagram of Lubrication System of General Electric Marine Geared Turbine

FOR EMERGENCY REPAIRS AT SEA.

In General.

1. The oil should be drained from the gear casing and, if necessary, pumped from the drain to the settling tanks.
2. Break all joints in the oil supply pipes and cover the ends of the pipes with canvas to exclude dirt.
3. Assemble the propeller clamp and lock the shaft tight.
4. Remove all bolts and nuts from the gear casing joint flanges.
5. Remove and place the upper half of the casings on the engine room floor.
6. Remove the oil nozzles where necessary.
7. Before unmeshing the low-speed pinion and the high-speed gear, and to avoid loss of time incident to obtaining the mesh of the teeth as originally made, mark the teeth clearly so that they can be properly reassembled.
8. After meshing the gears, all teeth in the entire train of wheels and pinions should be bearing in the direction that the propeller turns. To secure this condition it may be necessary to clamp down any bearings which may lift and apply a torque to the pinion shaft by means of the hand-turning device assembled on the forward end of the turbine shaft.
9. The back-lash should be ascertained and the driving faces of the teeth carefully examined to make certain that they are in proper contact and that the drive on both the starboard and port side gears are equalized. Before closing up the casings, remove all dirt and lint from the interior surfaces with clean wiping cloths.
10. Assemble the gear casing covers and replace the body bound bolts and dowels in the holes corresponding to the numbers stamped on these parts.

TO REPLACE A HIGH-SPEED PINION—ONE-PLANE TYPE.

1. Remove the upper halves of the bearings from the low-speed pinion shaft.
2. Secure the pinion and gear by tackle, placing the slings between the helixes of the pinion and gear.
3. Revolve the lower half of each bearing about 90 deg. and insert a bolt to hold the bearing joint in a vertical position and draw the pinion and gear away from the low-speed gear and high-speed pinion until the teeth are out of mesh.
4. Rest the pinion and gear on wooden blockings in the casing and avoid damage to the teeth.
5. In removing the high-speed pinion and shaft, first remove the bolts and nuts from the flexible jaw coupling and force the female halves apart as far as possible, removing the caps and the upper halves of the bearings and withdraw the pinion, replacing it by the spare one. Exercise care that the new pinion is properly meshed and that the shaft of its own weight lays solidly in the bearings.
6. When replacing a high-speed pinion and after the assembly is complete the teeth of the pinion need not be marked.
7. This lack of marking will indicate that the original pinion has been replaced.
8. To reassemble the low-speed pinion and high-speed gear, the teeth should be carefully meshed to the new markings as made and the mesh checked by comparing the measurements between the journals and the casing at the points where the shells are supported. These measurements must be equivalent to the thickness of the lower halves of the bearings.
9. Raise the shaft a slight distance and revolve the lower half of the bearing into position.
10. Lower the shaft, making sure that it lays solidly in the bearings.
11. Check the teeth markings for a second time.

IN GENERAL.

1. Examine the buckets and the thrust or "squealer" rings of the turbine periodically to see that the proper clearance is maintained.

2. Adjust the pop safety or sentinel valve on the condensing system to blow off at the proper pressure. When this valve operates, the emergency valve should immediately be tripped by hand to prevent the flow of steam to the condenser and to bring the turbine to rest.

3. All bolts, nuts, and other parts must be positively locked to prevent their working loose.

4. The emergency valve and the maneuvering valve should be reground when necessary and must be kept in condition to operate properly. The emergency valve should be tripped several times each day to make certain that it is in an operative condition, and the maneuvering valve should be worked each day in order to break the scale formation on the valve spindles.

5. The emergency governor and tripping device should be systematically cleaned and adjusted to make certain that they are in an operative condition, as most accidents to turbine units have resulted from the long disuse and neglect of the safety devices.

6. Make certain that the turbine and condenser are supported in such a manner that there can be no appreciable movement between them.

7. Examine the bucket wheels periodically for indication of incrustation and erosion. Under certain operating conditions it may be necessary to remove the incrustations and re-balance the machine.

8. Guard against erosion and corrosion of the buckets, shroud bands, and nozzle divisions by supplying dry steam and drying the turbine when shutting down by continuing the operation of the air pump while the turbine is hot.

9. The drain connection at the bottom of the turbine shell must be connected to a drain pump or a vacuum trap to avoid an accumulation of water in the shell.

10. All drain connections should be so arranged as to prevent vapors entering the turbine.

11. When the turbine is shut down for some time, close the header stop valve and open the drains in the connecting pipe and valves to prevent condensation leaking into the turbine.

12. Keep all drain valves in the steam and oil pipes properly packed and the seats ground to prevent leakage.

13. For efficient operation the normal steam and exhaust pressures must be maintained.

14. Allow no change in the propeller design to cause an overload on the turbine and gears, and at full speed, loaded, the propeller should revolve at not less than 90 r. p. m.

15. The spare parts and accessories for the turbine, gears, and auxiliaries should be carefully stowed to prevent damage by rust.

16. USE THE HAND VALVES FOR FULL SPEED ONLY. WHEN OPERATING AT LOW SPEEDS KEEP THE HAND VALVES CLOSED.

INTERNAL COMBUSTION MARINE ENGINES.

THE DIESEL OIL ENGINE.

One of the latest additions to the list of power producers is the "Heavy Oil Engine." The illustration shown is that of a 300 Horsepower "Diesel" and the sectional diagrams which follow will give a general idea of the interior of the ordinary engine of this type.

This engine operates on the principle of "High" or extreme compression of air up to five or six hundred pounds pressure per square inch. Heavy fuel oil under pressure of a single atmosphere (14.7) pounds (even if slightly heated) will not vaporize if sprayed and atomized but when the same oil is finely atomized and sprayed and atomized, but when the same oil is finely atomized and ignites.

The technical operation of the "Diesel" is in many ways similar to the gasolene engine but it is too complicated to be given here in detail, and the reader may obtain textbooks treating the subject in all its details.

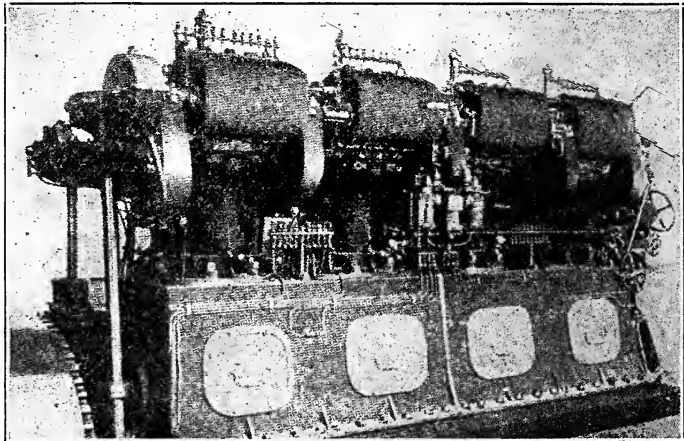

300 Horse Power Diesel Engine.

It may safely be said that combustion of fuel in this type of engine is more complete than by any other internal combustion engine, and that with proper adjustment, practically no carbon deposit remains.

The temperature in the engine is only about one-half that in the ordinary gasolene engine.

One peculiarity of the "Diesel" is that it can only be started by compressed air and several revolutions are necessary before it becomes oil fired.

Compressed air is also necessary for the oil atomized spray to feed the engine.

The air pump or compressor is attached to the engine and driven direct from the engine shaft.

Manufacturers of heavy oil engines are diligently at work attempting to produce a two-cycle engine but have not as yet succeeded. The type described is known as four-cycle.

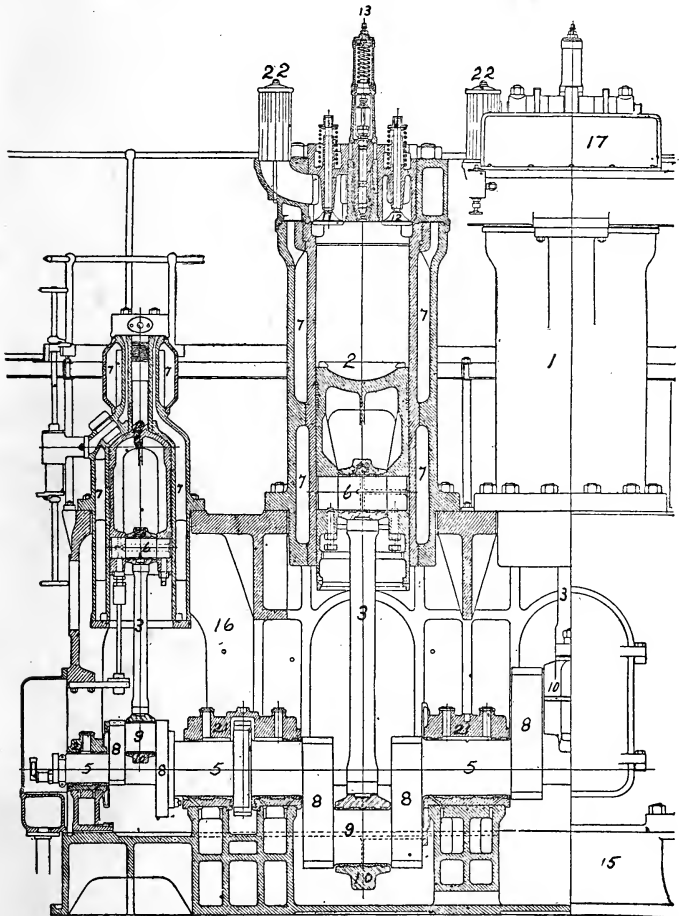

Sectional View, 500 Horse Power Diesel Engine.

List of parts on next page.

DIESEL ENGINE.

- 1 Cylinder.
- 2 Pistons.
- 3 Connecting rods.
- 4 Crank shaft.
- 5 Main bearings.
- 6 Crosshead pin.
- 7 Water jacket.
- 8 Crank webs.
- 9 Crank pin.
- 10 Crank pin brasses.
- 11 Air inlet valve.
- 12 Exhaust valve.
- 13 Fuel injection valve.
- 14 Two stage air compressor.
- 15 Engine bed.
- 16 Engine frame.
- 17 Cylinder head.
- 18 Cam levers.
- 19 Water pump.
- 20 Exhaust outlet.
- 21 Bearing caps.
- 22 Air inlet.
- 23 Crosshead brasses.

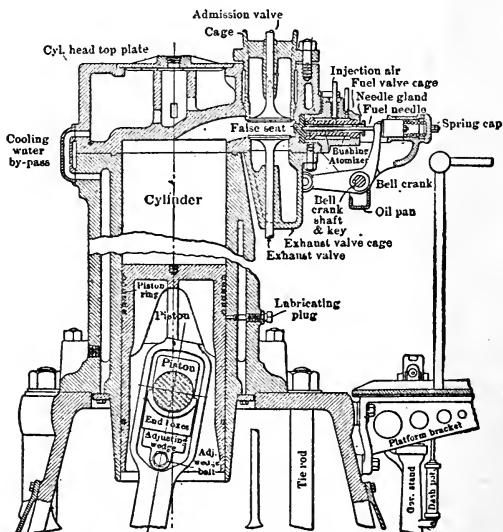

Sectional View of some Parts of another type 500 H.P. Diesel Engine

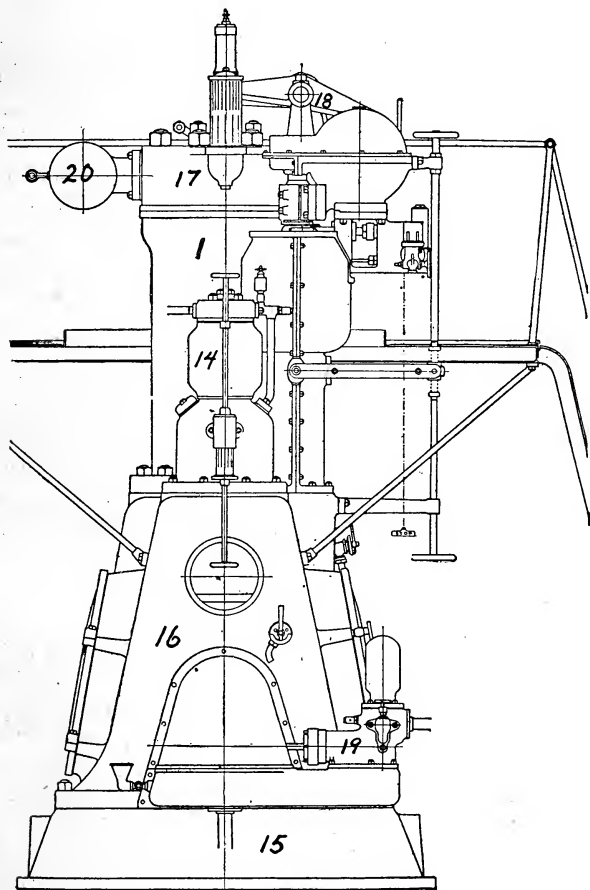

End View, 500 Horse Power Diesel Engine.

List of parts opposite page.

CARE AND SUPERVISION.

Constant Care is the keynote of success, and as no mechanical appliance has reasoning power, it remains for the man in charge to watch for the unexpected to happen and guard against serious results from accident.

More than ninety per cent of accidents so called are the result of gross carelessness and quite a number of the balance are preventable.

Both the designer and the manufacturer of each of the appliances which are used in a steam generating and power plant have done their best to ensure their product against breakage or failure to perform its duty, and it remains only for the person using the appliance to do the rest.

The boiler has the same relation to the steam power producing equipment of a vessel that the heart has to the human body, the engine and auxiliaries apply the power and it is well to consider what is necessary in order to ensure constant efficiency and the maximum of return for time and fuel used.

Each moving part, bearing, pinion or other part of a machine speaks a language which can be understood only by the man who takes pride in his work, and the mere time-server never gets intimately acquainted with his machine.

An unusual sound warns the careful fireman, oiler or water-tender as well as the most efficient engineer, that some part of the machinery is making its appeal for help.

The man who can supply what is needed and give aid promptly is the man who is worthy of the trust imposed upon him when human lives or welfare are at stake. He is the man who sooner or later goes higher.

Human ingenuity has devised aids, checks and counter checks to prevent disaster, but Care and Supervision are the qualities that save lives, perhaps including your own and property as well.

SUPERVISION OF BEARINGS AND MOVING PARTS.

If the following precautions are observed in caring for the bearings and moving parts of the engine, serious injury caused by overheating may be avoided.

The Oilers are cautioned against trusting any part of the machinery to always run well. A bearing, crankpin, crosshead, rod or guide may run for months without giving trouble, and suddenly heat up with little warning.

The feeling of parts and oiling of same should be done regularly, and with the greatest care, for if neglected, something will be sure to get hot some day, and bring disgrace along with it. Overheating can seldom be foreseen, but timely attention can always prevent serious injury to the parts, and soon reduce them to their normal condition.

Should any part of the machinery begin to heat, do not get excited and rush wildly about looking for six things at once, and in trying to cool one part, forget everything else, and thus cause a complete collapse; but keep cool, and do the right thing at the right time, and in a methodical manner. Refrain from shouting, or you may make everybody else as excited as you are yourself.

The above advice may to many seem needless, as we seldom meet a man who will own that he is excited or doing what is commonly known as losing his head, but when the Oiler has his experience with a hot pin or bearing, he will find it very difficult to follow our advice and keep cool.

An excited man is best out of the way when work has to be done rightly and promptly.

We will now proceed to give a few hints as to what to do when parts in motion show signs of heating.

HOT ECCENTRIC SHEAVES AND STRAPS.

The eccentric straps of many engines cause a great deal of trouble through heating, and there are very few eccentrics that will run without a slight supply of water. Many devices have been tried to prevent the excessive friction, but with the best of them, careful and regular attention is necessary.

Should a strap become hot enough to seize,* it invariably results in a doubled up rod, and if the engines are not stopped immediately it is more than likely that the whole of the valve gear may be carried away.

The very large eccentrics of single eccentric gears and those placed on the shaft couplings, will be found to require much more attention than the smaller ones fitted on the shaft. All should have large oil boxes fitted with syphon wicks, and it is a good plan to keep the boxes clear of the rods by placing washers on the bolts between the box and the rod.

This stops any water from the glands running down the eccentric rod, entering the boxes and washing out the oil, which it invariably does if the boxes are in direct contact with the rods, even if the boxes have lids, which are usually supplied.

Should a strap show signs of heating, plenty of oil, or oil and sulphur, or graphite should be applied, the water service put on, and the strap must be carefully watched. Should the oil not be feeding properly, the pipe and box must be cleaned, and refilled with clean oil, but should this not stop the heating, the engines had better be slowed, and on the slightest sign of the strap seizing, which will show itself by the whole gear shaking violently, the engines must be stopped at once.

On examining the strap, the brass liner will likely be found to be cracked, or one of the pins securing the liner to the strap will be found to have worked out.

A cracked sheave, or a piece of broken white metal will also cause the trouble, but these causes can, as a rule, only be discovered by stopping and stripping the gear.

The heating of the eccentrics and straps may be caused by the friction of the slide valves on their valve faces, often caused by priming, but this will generally show itself by the whole valve gear vibrating violently, and showing general signs of excessive strain. In this case the straps must be attended to at once, and then a dose of cylinder oil must be given the valves by means of the Lubricator or oil pump, usually fitted for the purpose. Should the vibration be very excessive, it is better to slow the engine until the cylinder oil has reduced the friction.

Many eccentrics that have been a constant source of trouble have been made satisfactory by running the bottom half in an oil and water bath.

*Seize—to jam or bind, sticking to the moving part.

HEATING OF GUIDES.

This may be detected by sight, by touch and also by smell, and may be caused by want of oil, or if fitted with circulation water at the back, by the stoppage of the water service. If taken in time, the guide can be cooled by a liberal application of oil with condensed water.

If very hot, slow the engines down, and use plenty of oil mixed with sulphur or graphite if you have them on board.

If the guides are scored and continue to give trouble, a small quantity of white lead mixed with Castor or Engine oil to a thick paste, and applied from time to time, will be found to give good results.

When reasonably cooled, the engines can be opened out again, and the guide brought to its normal condition by using oil and condensed water.

Should the circulating water pipe be stopped, the pipe must be cleared.

HOT CROSSHEAD.

A hot Crosshead can be detected by feeling it, and if hot enough to give off an odor the engines should be slowed down at once.

The odor from a heated bearing is similar to that given off by fat burning over the fire, and is caused by the oil being burned by the excessive heat generated by friction. Once experienced the smell is never forgotten.

The cooling of a Crosshead is generally a long job, often taking six or eight hours, and great care must be taken to prevent the heat from spreading to the piston rod and guide shoes. If constant oiling will not cool it while the engines are at full speed, the engines must be slowed down. If this does not answer, the oil is either not reaching the pin, or the bearing is too tight. If in a position to stop, this should be done, the brasses slacked back, and the oil ways cleaned, but if the steamer is in confined water, where it would be dangerous to stop the engines, the hose must be used.

This naturally makes a nasty mess, and is liable to crack the crosshead brasses, causing trouble to the Crankpin and Guides by washing dirt into, and oil out of the bearings.

It may generally be assumed that if the hose has to be used it is time to slow down or come to a stop, to readjust the bearing.

HOT PISTON ROD.

This can be detected in four ways, by change of color of the rod, by sense of touch and smell, and by spitting upon it.

If the expectoration flies off the rod as it would off a hot plate, look out for trouble; but if it adheres slightly the rod is all right. If it is hot enough to burn the packing, the odor given off is somewhat like burning indiarubber, but feeling the rod by hand is the surest way, and any heating is easily detected.

If considered too hot, but noticed before becoming dangerously so, swabbing with cylinder oil will generally bring it around all

right, but if this has no effect, the gland must be slacked back, the rod being swabbed at intervals, until there is a slight escape of steam or water. When this occurs, the rod will gradually cool, more steam and water escaping as this proceeds, and when considered in its normal condition the gland should be set up again gently.

These methods of treatment will usually answer in dealing with rods packed with soft packing, and in some cases with metallic packing, but with the latter great care and attention must be given to prevent the packing melting and seizing the rod.

Warning in such cases is sometimes given by a few streaks of the melted packing showing on the rod, and in such a case the engines should be slowed down and the same cooling methods adopted as before.

Should the metallic packing seize the rod, the engines should be stopped, if not, the result will be a badly scored rod, necessitating many hours work removing the fused metal from the rod and stuffing box. Newly packed glands, and especially those of new engines taken over after a trial trip require constant attention for a day or two, but once they are in good running order, with regular attention, but little further trouble may be expected.

HOT MAIN BEARINGS.

The Main Bearings should be given as much attention as any other part of the machine, as neglect will cause serious trouble and heavy expense. Should any of these bearings become so hot as to melt the metal, it is usually impossible to renew the brass without lifting the shaft which is a matter of great expense and delay.

When a bearing shows signs of heating, give it a good supply of oil, and note particularly if the oil is getting into the bearing, if not, lift off the oil box and see if the oil will enter the bearing through the oil holes, and if it does so the bearing will cool down. The oil box and wicks must be thoroughly cleaned and replaced. If the bearing, although taking the oil, continues to heat, apply oil and sulphur or graphite and run water gently on each side of the brass, but not on the cap; slack back the set screws, and get a sledge hammer and wrench ready for slacking back the nuts.

If the bearing continues to heat with the water service on, note the position of the nuts, slow the engine down and proceed to slack back the nuts with the sledge. A turn of half a square of the nut will generally be found ample. Continued heating of bearing after being liberally supplied with oil and water is generally caused by grit having entered with the oil, or a piece of white metal having worked loose. Slacking the bearing and slowing the engine may give it a chance to work out.

If the bearing continues to get dangerously hot, and the oil shows any sign of burning, the engine must be stopped, and the brass lifted and examined.

Once the bearing is too hot for the oil, no amount of water will make it run, and continued use will only result in scoring the shaft and metal, causing the bearing to wear rapidly and continue to give trouble until properly adjusted.

Some main bearings are fitted with a hand hole through which the bearing may be felt, and a large quantity of oil may be poured on the bearing through this handhole.

HOT CRANKPIN.

This being the largest and most important moving part that cannot be adjusted while in motion, it naturally should have the greatest care devoted to it, and any sign of heating should be immediately attended to and corrected.

It can only be felt during a small portion of its motion, therefore, one has to be particularly careful. The brasses should always be felt on both sides, as a brass will often be quite hot on one side before showing the slightest sign of heat on the other.

The Oiler should practice feeling the crankpin brasses with both right and left hands, at the same time being careful to prevent injury to his hands. Should the bearing show signs of heating apply water service carefully.

A liberal supply of oil at frequent intervals will usually reduce the heat if the oil ways are clear, if not, the water must be applied until the brass is cooled.

If, on shutting the water off, the brasses heat again, the engines ought to be stopped and the cause ascertained. If it is a choked oil pipe, the brasses will generally run all right after clearing the pipe and starting, but if not, the cause may generally be laid to a piece of white metal having become loose, thereby causing excessive friction. In the latter case the brasses should be cleaned out and the bearing readjusted.

While on the subject of Crankpin Bearings, it is well to enter a protest against the constant use of water as a cooling medium. If fitted with white metal as is the usual practice, crankpin bearings will run even when considerably heated and if the heat in any bearing is not enough to decompose the lubricant, the bearing will run well if it is regularly oiled.

If on feeling the crankpin brasses a small quantity of oil in fairly liquid state remains on the hand, and the brasses feel hot, but moist, the bearing may be said to be all right; but if the brasses give off a dry burning feeling to the hand, things are going wrong.

HOT THRUST BLOCK.

With ordinary care and attention the Thrusts are not apt to become dangerously overheated, but this may happen by reason of carelessness or faulty design of the parts. Thrusts are run in a mixture of oil and water, and if enough oil is given to combine, generally run smoothly. If they show signs of heating, it is not enough to simply increase the water supply; the oil also must be increased, and the pipes examined to see that they are free.

In the Horse Shoe Type of Thrust which has the shoes hung on a through bolt and adjusted by nuts, if any shoe shows continued heating, it can be slacked back slightly, care being taken to again secure it firmly in place, by use of the adjusting nuts.

Some Thrusts run in a bath of oil. In either case the oil or mixture must be added to from time to time, or hot collars will be the results.

USEFUL INFORMATION CONCERNING AIDS TO NAVIGATION

Buoy colors, numbers, and shapes.—Conforming with United States statutes, the following order is observed, viz:

In approaching a channel, etc., from seaward, red buoys, with even numbers, will be found on the starboard side; black buoys, with odd numbers, on the port side; red and black horizontally striped buoys on obstructions with channelways on either side of them; and white and black perpendicularly striped buoys in mid-channel, and must be passed close-to.

Perches with balls, cages, etc., on buoys, mark turning points, the color and number of the buoy indicating on which side it shall be passed.

Nun buoys, properly colored and numbered, are usually placed on the starboard side, and can buoys on the port side, of channels.

Day beacons are constructed and distinguished with special reference to each locality, and particularly in regard to the background upon which they are projected. Beacons on the sides of channels when practicable are colored to conform to the coloring of buoys, subject to the above conditions as to background.

Buoy Lists, obtainable on application to the Division of Publications, Department of Commerce, Washington, D. C., contain full description of all aids to navigation. Notices to Mariners give information of all changes in aids.

Protection of aids.—It is unlawful to interfere with or make fast to an aid to navigation, and collision with an aid must be promptly reported to the nearest inspector of steamboats.

Defects in aids to navigation should be reported at once to the nearest lighthouse inspector.

Distances of visibility for objects of various elevations above sea level:

Height, in feet.	Distance, in nautical miles.	Height, in feet.	Distance, in nautical miles.	Height, in feet.	Distance, in nautical miles.
5	2.55	50	8.08	95	11.14
10	3.61	55	8.48	100	11.43
15	4.43	60	8.85	110	11.99
20	5.11	65	9.21	120	12.52
25	5.71	70	9.56	130	13.03
30	6.26	75	9.90	140	13.52
35	6.76	80	10.22	150	14.00
40	7.23	85	10.54	200	16.16
45	7.67	90	10.84		

Add distance for height of observer's eye above sea level.

SIGNALS USED BY MARINERS.

SIGNALS FROM PILOT HOUSE TO ENGINE ROOM

When engine is stopped, One bell for Ahead Slow.

When running ahead slow, Jingle for Full Speed Ahead.

When running full speed ahead, One bell for Slow Down.

When running ahead slow, One bell for Stop.

When stopped, Two bells for Astern.

When running astern, jingle bell for full speed Astern.

When running astern, One bell for Stop.

When running full speed ahead, Four bells for Full Speed Astern.

When running ahead slow, Three bells for Full Speed Astern.

SIGNALS OF DISTRESS.

When a vessel is in distress and requires assistance from other vessels or from the shore, the following shall be the signals to be used or displayed by her, either together or separately:

IN THE DAYTIME—

(1) A gun or other explosive signal fired at intervals of about a minute;

(2) The International Code Signal of Distress indicated by NC;

(3) The distant signal, consisting of a square flag, having either above or below it a ball or anything resembling a ball.

(4) The distant signal, consisting of a cone point upward, having either above or below it a ball or anything resembling a ball;

(5) A continuous sounding with any fog signal apparatus.

AT NIGHT—

(1) A gun or other explosive signal fired at intervals of about a minute;

(2) Flames on the vessel (as from a burning tar barrel, oil barrel, etc.);

(3) Rockets or shells, throwing stars of any color or description, fired one at a time at short intervals;

(4) A continuous sounding with any fog-signal apparatus.

INTERNATIONAL CODE OF SIGNALS

INSTRUCTIONS HOW TO SIGNAL

In the following instructions the ship making the signal is called A; the ship signaled to is called B

HOW TO MAKE A SIGNAL

Ship A, wishing to make a signal, hoists her Ensign with the Code Flag under it.

If more than one vessel or signal station is in sight, and the signal is intended for a particular vessel or signal station, ship A should indicate which vessel or signal station she is addressing by making the distinguishing signal (i. e., the signal letters) of the vessel or station with which she desires to communicate.

If the distinguishing signal is not known, ship A should make use of one of the signals DI to DQ.

When ship A has been answered by the vessel she is addressing, she proceeds with the signal which she desires to make, first hauling down her Code Flag if it is required for making the signal.

Signals should always be hoisted where they can best be seen, and not necessarily at the masthead.

Each hoist should be kept flying until ship B hoists her Answering Pennant "Close up."

When ship A has finished signaling she hauls down her Ensign, and her Code Flag, if the latter has not already been hauled down.

HOW TO ANSWER A SIGNAL

Ship B (the ship signaled to), on seeing the signal made by Ship A, hoists her Answering Pennant at the "Dip."

(A flag is at the "Dip" when it is hoisted about two-thirds of the way up, that is, some little distance below where it would be when hoisted "Close Up.")

The Answering Pennant should always be hoisted where it can best be seen.

When A's hoist has been read, looked up in the Signal Book, and is understood, B hoists her Answering Pennant "Close Up" and keeps it there until A hauls her hoist down.

B then lowers her Answering Pennant to the "Dip" and waits for the next hoist.

If the flags in A's hoist can not be made out, or if, when the flags are made out, the purport of the signal is not understood, B keeps her Answering Pennant at the "Dip" and hoists the signal OWL or WCX, or such other signal as may meet the case; and when A has repeated or rectified her signal, and B thoroughly understands it, B hoists her Answering Pennant "Close Up."

Note.—Complete instructions for using the International Code may be found in the International Code Book, published by the Hydrographic Office, Washington, D. C.

INTERNATIONAL CODE OF SIGNALS

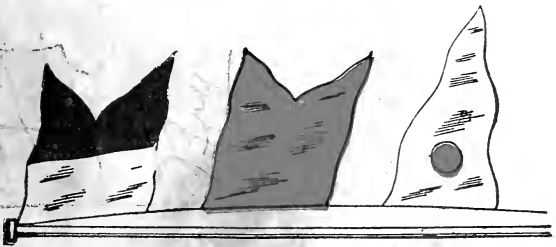
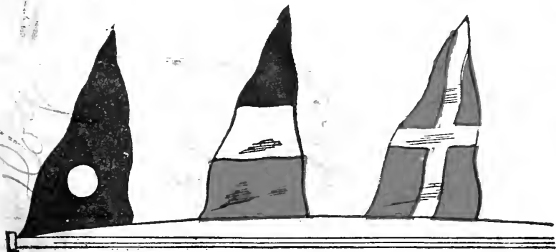
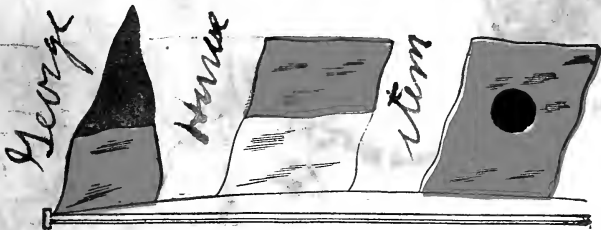

G

H

I

D

E

F

A

B

C

INTERNATIONAL CODE OF SIGNALS

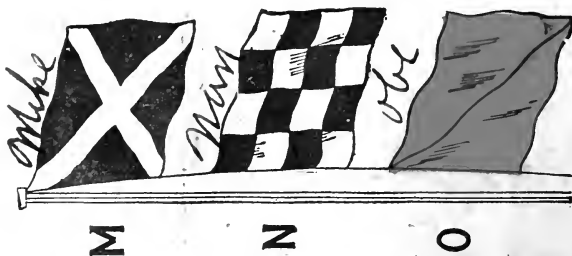
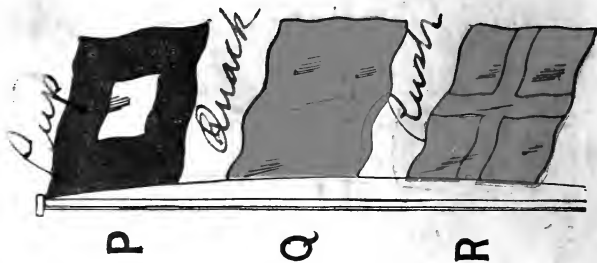

INTERNATIONAL CODE OF SIGNALS

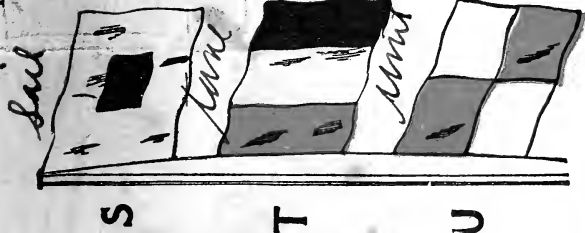

S

T

U

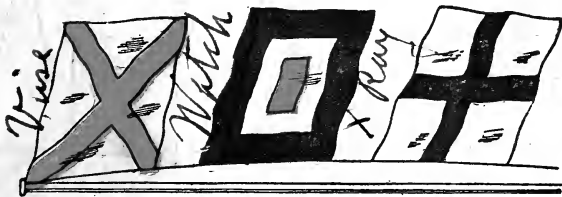

V

W

X

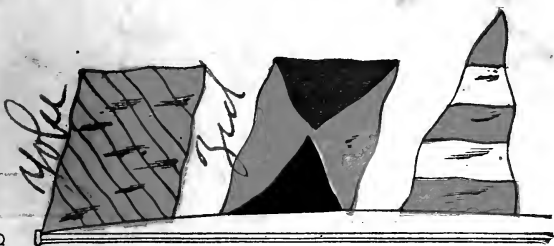

Y

Z

“CODE FLAG”
AND “ANSWERING
PENNANT”

When used as Code Flag, hoist under the ensign.
When used as Answering Pennant, hoist at masthead or where best seen.

UNITED STATES STORM WARNINGS

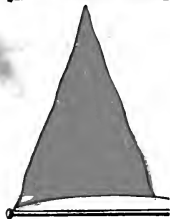

EASTERLY WINDS

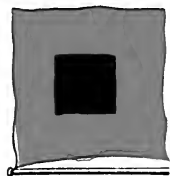

STORM SIGNAL

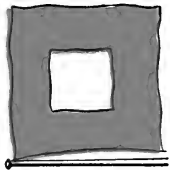

CAUTIONARY SIGNAL

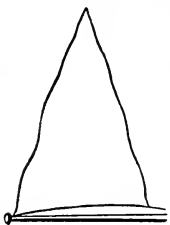

WESTERLY WINDS

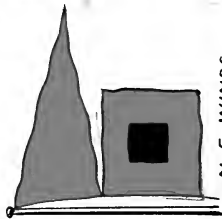

N.E. WINDS

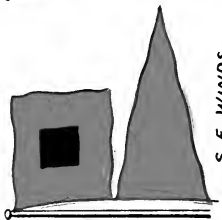

S.E. WINDS

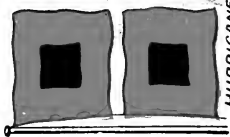

HURRICANE WARNING

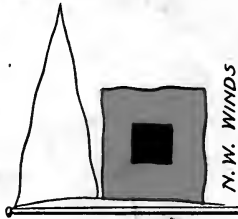

N.W. WINDS

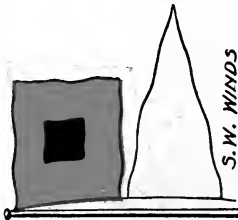

S.W. WINDS



NIGHT WARNINGS

UNITED STATES STORM WARNINGS.

The Warnings Adopted by the United States Weather Bureau for Announcing the Approach of Wind Storms are as follows:

Storm Warning (a red flag, eight feet square, with black centre, three feet square), indicates that a storm of marked violence is expected. This flag is never used alone.

Red Pennant (eight feet hoist and fifteen feet fly) displayed with the flag, indicates easterly winds, that is, from the northeast to south, inclusive, and that the storm centre is approaching.

White Pennant (eight feet hoist and fifteen feet fly) displayed with the flag, indicates westerly winds, that is, from north to southwest, inclusive, and that the centre has passed.

Red Pennant if hoisted above the Storm Warning, winds are expected from the **NORTHEAST QUADRANT**; when below, from the **SOUTHEAST QUADRANT**.

White Pennant if hoisted above the storm warning, winds are expected from the **NORTHWEST QUADRANT**; when below, from the **SOUTHWEST QUADRANT**.

Night Storm Warnings—By night a **RED LIGHT** will indicate **EASTERLY WINDS**; a **WHITE** above a **RED LIGHT** will indicate **WESTERLY WINDS**.

Hurricane Warning (two storm warning flags, red with black centres, displayed one above the other) indicates the expected approach of a tropical hurricane or of an extremely severe and dangerous storm.

No Night Hurricane Warnings are displayed.

A yellow flag with white centre is a cautionary signal.

Signals should be read from the top of the staff downward. These signals indicate the weather forecasts for the twenty-four hours commencing at 8 o'clock A. M.

MORSE SIGNAL CODE.

- indicates a LONG of about 3 seconds' duration.
 — indicates a SHORT of about 1 second duration.
 Preparative Signal to attract attention — — — — — etc.
 Answering Signal, or, I understand — — — — — etc.
 Interval between each flash or sound..... 1 second.
 Interval between each letter..... 3 seconds.
 Interval between each word..... 6 seconds.

A.....	— —	N.....	— —
B.....	— — — —	O.....	— — — —
C.....	— — — — —	P.....	— — — — —
D.....	— — — — —	Q.....	— — — — —
E.....	— —	R.....	— — — — —
F.....	— — — —	S.....	— — — —
G.....	— — — — —	T.....	— — — —
H.....	— — — — —	U.....	— — — —
I.....	— — — — —	V.....	— — — —
J.....	— — — — —	W.....	— — — —
K.....	— — — — —	X.....	— — — —
L.....	— — — — —	Y.....	— — — —
M.....	— — — — —	Z.....	— — — —

CONVENTIONAL SIGNALS: THEIR EQUIVALENT LETTERS AND THE METHOD OF ANSWERING THEM.

Meaning.	Sign.	Equivalent letter and how made.	How answered.
Preparative.	- - - - - etc.	By a succession of E's in one group.	By the general answer T
Answer.	—	T (singly).	
Break sign.	. - - - -	I I as separate letters.	
Stop.	- - - - -	I I I as separate letters.	
Finish of a message.	- - - - -	V E as one group.	- - - - R - - - - D as separate letters.
Erase sign.	- - - - - etc.	By a succession of E's as separate letters.	By a succession of E's as separate letters.
Annul.	- - W - - - W - - -	W W as one group.	By W W as one group.
Repeat word after — (when a single word is required).	<p>I - - M - - I - -</p> <p>W - - A - -</p> <p>followed by the word preceding the one required.</p>	<p>I M I as one group.</p> <p>W A as separate letters.</p>	By the general answer T.
Repeat all after — (if more than one word is required).	<p>I - - M - - I - -</p> <p>A - - A - -</p>	<p>I M I as one group.</p> <p>A A as separate letters.</p>	By the general answer T
Repeat all (if the whole message is to be repeated.)	<p>I - - M - - I - -</p> <p>A - - L - - L - -</p>	<p>I M I as one group.</p> <p>A L L as separate letters.</p>	By the general answer T

MORSE SIGNAL CODE—Continued

THE USE OF THE SPECIAL SIGNS

The Preparative.

Is used to call attention, and is answered by the General Answer.

The General Answer.

Is made by a long flash —, or letter T.

The Break Sign.

Is to be used between the address of the receiver and the text of the message, and, after the text, if the name of the sender is signalled.

The Stop.

Is made by three separate letter I's.

THE FINISH

Is to be made by V E in one group at the completion of a message, and is to be answered, if the message is understood, by R D in separate letters. N. B.—R. D. means Read.

The Erase

Is made by a series of E's as separate letters, and is used to erase a word or group that has been wrongly sent, and is to be answered by the Erase.

The Annul

Is made by W W in one group, and is used to negative ALL the message that has gone before, and is to be answered by the Annul.

Method of Answering

Each word when understood is to be answered by one long flash — (T).

If a word is not answered, the sender is to repeat it until answered by a long flash.

At the end of the message, if understood, receiver will make — — — — (or R D), meaning Read.

The Erase and Annul signs are to be answered by their own signs.

Method of Signalling Numbers

All numerals, whether representing time, distance, numbers, etc., are to be spelled in full.

If the receiver requires any word to be repeated, he makes

Repeat W A

(or, repeat word after) the word—(or, if necessary, words) preceding the doubtful word.

Note.—When W A is only sent, the Repeat sign is implied.

If the receiver requires the remainder of the message, he makes

Repeat A A

(or, repeat all after) the word—preceding the doubtful ones.

If the receiver wants all the message repeated, he makes

Repeat A L L

When he requires no more repetition, he makes — — — —
— — — — (or, R. D.) which means the signal is read.

MORSE SIGNAL CODE—Continued

If a Mistake is Made in a Word

The sender makes the Erase sign — — — — etc., E's as separate letters, which is to be answered by the Erase sign.
N. B.—This only applies to the last word made.

If a Whole Message Requires to be Negatived

The sender makes the Annul — — — — (or, W W as one group), which is to be answered by the Annul.

LIGHT AND SOUND SIGNALS, ACCORDING TO COLOMB'S FLASHING SIGNALS SYSTEM.

The following urgent and important signals may be made at night or in thick weather, either by long and short flashes of light or by long and short sounds on a steam whistle, siren, fog horn, etc.:

Instructions for the Use of Flashing or Sound Signals.

With flashing signals the lamp must always be turned toward the person addressed.

To attract attention, a series of rapid short flashes or sounds should be made and continued until the person addressed gives the sign of attention by doing the same.

If, however, it is supposed that the person addressed can not reply, the signal may be made after a moderate pause, or, under certain circumstances, the communication may be made without preparatory signs.

After making a few rapid short flashes or sounds as an acknowledgment, the receiver must watch or listen attentively until the communication is completed, when he must make the sign indicated below, showing that the message is understood.

If the receiver does not understand the message, he must wait until the signal is repeated.

Duration of short flashes or sounds —	1 second.
Duration of long flashes or sounds —	3 seconds.
Interval between each flash or sound.....	1 second.
Answer, or, "I understand" — — — — — etc.	

SIGNALS

You are standing into danger.....	— — — —
I want assistance; remain by me.....	— — — —
Have encountered ice	— — — —
Your lights are out (or, need trimming)	— — — — —
The way is off my ship; you may feel your way past me	— — — —
Stop, or, heave to; I have something important to communicate	— — — —
Am disabled; communicate with me	— — — —

When a vessel is in tow, the following signals made by flashes of light may be used between her and the tug or towing vessel:

Steer more to starboard.....	—
Steer more to port.....	—
Cast off hawsers	— — — —

SEMAPHORE SIGNALS.

Instructions for the Use of the British Movable Semaphore.

THE INDICATOR.

The Indicator denotes from which side the signs are to be read, but when first shown it is to call attention, and may be considered the preparative signal. When closed it denotes the finish of the communication.

HOW TO SEMAPHORE.

The person intending to Semaphore will make the International Code Signal VOX (I am going to Semaphore to you), and set his Semaphore at the alphabetical sign (see illustration) with the Indicator out, and wait until the person to whom the Semaphore signal is to be made hoists his answering pennant Close Up. Then he will proceed with the communication by spelling, making a momentary pause between each sign or letter; the arms are to be dropped between each word or group, the Indicator alone remaining out.

Should the answering pennant be dipped by the person taking in the signal, the last two words are to be repeated until the answering pennant is again hoisted Close Up.

When in the middle of a spelling signal numerals have to be made, the Semaphore is to be put at the numeral sign (see illustration), and the number then made. When the numeral signal is finished the alphabetical sign is to be made and the communication by spelling proceeded with.

HOW TO ANSWER AND TAKE IN SEMAPHORE SIGNALS.

The answering pennant is to be hoisted Close Up by the person taking in the Semaphore signal, thus denoting he is ready to read and write down the signal.

It is to be "dipped" when a word is lost, and the person making the signal is then to repeat the two last words until the answering pennant is hoisted again Close Up.

In answering by the Semaphore the arm in position (1) represents the answering pennant at the dip.

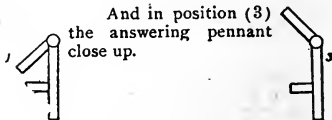

And in position (3) the answering pennant close up.

SEMAPHORING BY HAND FLAGS.

British Wig-Wag.

The British method of Semaphoring by flags held in the hand which is shown in illustration is exactly the same as the British Movable Semaphore system, the positions of the apparatus which denote the letters, numbers, and special signs being, it will be seen, identical in each case, and the only difference being in the apparatus employed.

THE BRITISH MOVABLE SEMAPHORE.									
SEMAPHORE SIGNS.					GOVERNING SIGNS.				
<p>Indicator.</p>									
					Preparative. When closed it denotes the finish.	Alphabet- ical.	Numeral.	Annul or negative.	
SIGNS.									
Alphabetical Signification.	A	B	C	D	E	F	G	H	I
Numerical Signification.	1	2	3	4	5	6	7	8	9
SIGNS.									
Alphabetical Signification.	J	K	L	M	N	O	P	Q	R
Numerical Signification.	<i>Also the alpha- betical sign.</i> 0								
SIGNS.									
Alphabetical Signification.	S	T	U	V	W	X	Y	Z	

NOTE.—If a numeral signal is to be followed by words, the end of the numerical signification of the signs is shown by the alphabetical sign being made, indicating that spelling is again to commence.

DISTANT SIGNALS.

1. Distant Signals are required when, in consequence of distance or the state of the atmosphere, it is impossible to distinguish the colors of the flags of the International Code, and, therefore, to read a signal made by those flags; they also provide an alternative system of making the signals in the Code, which can be adopted when the system of flags can not be employed.

2. Three different methods of making Distant Signals are explained below:

- (a) By Cones, Balls, and Drums.
- (b) By Balls, Square Flags, Pennants, and Whefts.
- (c) By the Fixed Coast Semaphore.

The last method (Fixed Coast Semaphore) is not necessarily a method of making Distant Signals, as it can be, and is, used at close quarters and under conditions when flags could equally be employed, but it has been placed here under the heading of Distant Signals for ease of explanation.

3. The Characteristic of Distant Signals is the Ball; one ball at least appearing in each hoist of the Distant Code. In the case of the Semaphore the ball is replaced by a Disc.

4. Hitherto only three Symbols have been required for Distant Signaling, but the increase made in the number of flags of the International Code renders four Symbols necessary, in order that it may be possible to provide a distant hoist to represent each of the flags of the Code (i. e., letters of the alphabet).

5. Distant Signals are made

From a ship—by hoisting shapes.

From the shore—by hoisting shapes, or by the position of the arms of a Semaphore.

6. The Shapes used as Symbols are:

- (a) A Cone point upward.

A Ball.

A Cone point downward, and

A Drum. (The Drum should be at least one-third greater in height than the Ball.)

- (b) A square Flag may be substituted for the cone point upward.

A Ball.

A Pennant may be substituted for the cone point downward, and

A Pennant with the fly tied to the halyards, or a Wheft for the drum. (A wheft is any flag tied in the center.)

As in calms, or when the wind is blowing toward or from the observer, it is impossible to distinguish with certainty between a square flag, pennant, and wheft, and as flags when hanging up and down may hide one of the balls and so prevent the signal being understood, the system of cones and drums is preferable to that of flags, pennants, and whefts.

- (c) In signaling by the Semaphore, the positions of the arms represent the shapes.

































7. To simplify the "Taking in," "Reporting," and "Reading off" of the Distant Signals; the four positions of the Semaphore Arms, and the four Symbols have been numbered 1, 2, 3, 4.

GENERAL ALPHABETICAL TABLE FOR MAKING THE INTERNATIONAL CODE SIGNALS BY MEANS OF DISTANT SIGNALS BY SHAPES.

"PREPARATIVE," "ANSWERING," OR "STOP," after each complete signal.		ANNUL THE WHOLE SIGNAL	
A	1 1 2	I	2 1 2
B	1 2 1	J	2 1 3
C	1 2 2	K	2 1 4
D	1 2 3	L	2 3 1
E	1 2 4	M	2 2 2
F	1 3 2	N	2 2 4
G	1 4 2	O	2 3 1
H	2 1 1	P	2 3 2
Q	2 3 3	R	2 3 4
Y	3 2 3	S	2 4 1
Z	3 2 4	T	2 4 2
SPECIAL SIGNS.		Code Flag Sign.	4 2 - 1
Alphabetical Sign.		4 2 2	
Numeral Sign.		4 2 3	
Finishing sign after completion of word or number when spelling or making numeral signals.		4 3 2	
V	3 1 2	W	3 2 1
X	3 2 2		

If no cones are available, a square flag may be substituted for the cone point upward, a pennant for the cone point downward, and a wheel for the drum.

GENERAL ALPHABETICAL TABLE FOR MAKING THE INTERNATIONAL CODE SIGNALS BY MEANS OF DISTANT SEMAPHORE.

"PREPARATIVE," "ANSWERING," or "STOP" after each complete signal.		ANNUL THE WHOLE SIGNAL.	
			
A 1 1 2 	I 2 1 2 	Q 2 3 3 	Y 3 2 3 
B 1 2 1 	J 2 1 3 	R 2 3 4 	Z 3 2 4 
C 1 2 2 	K 2 1 4 	S 2 4 1 	SPECIAL.
D 1 2 3 	L 2 2 1 	T 2 4 2 	Code Flag Sign. 4 2 1 
E 1 2 4 	M 2 2 3 	U 2 4 3 	Alphabetical Sign. 4 2 2 
F 1 3 2 	N 2 2 4 	V 3 1 2 	Numeral Sign. 4 2 3 
G 1 4 2 	O 2 3 1 	W 3 2 1 	4 3 2 
H 2 1 1 	P 2 3 2 	X 3 2 2 	Finishing sign after completion of word or number, when spelling or making numeral signals. 

- 1 representing the Semaphore Arm pointing upward, on the *opposite* side to the indicator, a Cone with the point upward, or a square Flag.

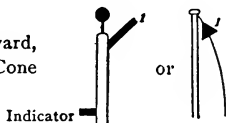

- 2 representing the Semaphore Arm pointing horizontally, on the *opposite* side to the indicator, or a Ball.

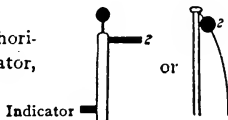

- 3 representing the Semaphore Arm pointing downward, on the *opposite* side to the indicator, a Cone with the point downward, or a Pennant.

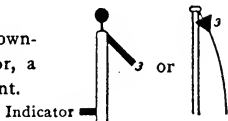

- 4 representing the Semaphore Arm pointing horizontally, on the *same* side as the indicator, a Drum, or a Pennant with the fly tied to the halyards, or a Wheft.

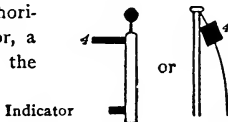

8. To facilitate signaling by Semaphore or Shapes, the signals representing the letters of the alphabet have been arranged in numerical order, the figures representing the signal for the letter A being the first in numerical sequence.

Thus A is represented by 1 1 2.

Thus B is represented by 1 2 1.

Thus C is represented by 1 2 2,
etc., etc.

The signals representing the letters from A to G begin with 1,



Those from H to U begin with 2,

Those from V to Z begin with 3,

And the Special Signs (i. e., Code Flag, Alphabetical, Numerical, and Finishing Signs) begin with 4. (See illustration.)







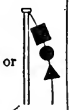
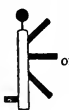

9. The Code Flag Sign 4 2 1 (see illustration) is always to be shown before signals taken from the General Vocabulary of the International Code are commenced.

10. When signals are made by the Semaphore the disc is always to be kept up until the signal is completed, and the hoist is to be read from the top arm downward.

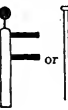
11. The Stop Signal  or  is to be made at the end of each complete signal.

12. With two Balls, two Cones, and one Drum, every signal in the International Code can be made, each hoist representing one letter of the two, three, or four letters forming the signal.

EXAMPLE OF A SIGNAL FROM THE INTERNATIONAL CODE
MADE BY FIXED SEMAPHORE OR DISTANT SIGNALS.

 or 	 or 	 or 	 or 	 or 
4 2 1—Code Flag Sign, indicating that the signal which follows is taken from the General Vocabulary of the International Code.	1 2 3—D.	2 2 4—N	2 1 2—I.	2—Stop, i. e. Signal is ended.

Looking DNI out in the International Code, we find it to be "Pilot boat is advancing toward you."

ALPHABETICAL DISTANT SIGNALS.

13. When it is desired to spell a word by Distant Signals, the Alphabetical Sign 4 2 2 (see illustration) is to be shown first. All the hoists which follow until the Finishing Sign 4 3 2 (see illustration) is shown are to be understood as representing the particular letters of the alphabet allotted to them in illustrations which, when combined, spell the word which it is desired to signal.

NUMERAL DISTANT SIGNALS.

14. When it is desired to signal numbers by Distant Signals, the Numeral Sign 4 2 3 (see illustration) is to be shown first. After that sign has been shown, and until the Finishing Sign 4 3 2 (see illustration) is shown, the hoists representing the various letters of the alphabet (see illustration) are to be understood as having the numerical values which are allotted to the particular letters under the system of making Numeral Signals by flags.

Thus, after the Numeral Sign 4 2 3 has been shown, the Distant Signal hoist representing the letter A will mean the number 1, that representing B will mean 2, that representing K will mean 11, and so on.

SPECIAL DISTANT SIGNALS.

15. As shown in the Example to Paragraph 12, above, signals from the General Vocabulary of the International Code require to

be made by more than one hoist, which involves loss of time. Arrangements have, however, been adopted by which many important signals can be made by one hoist only. These signals are called "Special Distant Signals," and are represented by numbers as explained below, and not by letters.

16. The Special Distant Signals are distinguished from Distant Signals taken from the General Vocabulary of the International Code by the fact that they are not preceded by the Code Flag Sign and that the Stop Signal immediately follows the single hoist representing the particular "Special Distant Signal" which is being made.

EXAMPLE OF A SPECIAL DISTANT SIGNAL

MADE BY SEMAPHORE OR DISTANT SIGNALS.

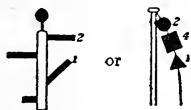

2 4 1

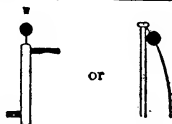

Stop

SPECIAL DISTANT SIGNALS.

Made by a Single Hoist followed by the Stop Signal. Arranged Numerically for Reading off a Signal.

These signals may be made by semaphore, by cones, balls, and drums, or by square flags, balls, pennants, and whetfs.

Signal 2—"Preparative," "Answering," or "Stop," after each complete signal.

- " 12—Aground; want immediate assistance.
- " 21—Fire, or leak; want immediate assistance.
- " 22—Annul the whole signal.
- " 23—You are running into danger; or, Your course is dangerous.
- " 24—Want water immediately.
- " 32—Short of provisions; starving.
- " 42—Annul the last hoist; I will repeat it.
- " 112—I am on fire.
- " 121—I am aground.
- " 122—Yes, or affirmative.
- " 123—No, or negative.
- " 124—Send Lifeboat.
- " 132—Do not abandon the vessel.
- " 142—Do not abandon the vessel till the tide has ebbed.
- " 211—Assistance is coming.
- " 212—Landing is impossible.
- " 213—Bar or entrance is dangerous.
- " 214—Ship disabled; will you assist me into port?
- " 221—Want a pilot.
- " 223—Want a tug; can I obtain one?
- " 224—Asks the name of ship (or signal station) in sight; or, show your distinguishing signal.
- " 231—Show your ensign.

- “ 232—Have you any despatches (message orders, or telegrams) for me?
 “ 233—Stop, bring-to, or come nearer; I have something important to communicate.
 “ 234—Repeat signal, or hoist it in a more conspicuous position.
 “ 241—Cannot distinguish your flags; come nearer, or make Distant Signals.
 “ 242—Weigh, cut, or slip; wait for nothing; get an offing.
 “ 243—Cyclone, hurricane, or typhoon expected.
 “ 312—Is war declared? or, Has war commenced?
 “ 321—War is declared; or, War has commenced.
 “ 322—Beware of torpedoes; channel is mined.
 “ 323—Beware of torpedo boats.
 “ 324—Enemy is in sight.
 “ 332—Enemy is closing with you; or, You are closing with the enemy.
 “ 342—Keep a good look-out, as it is reported that enemy's men-of-war are going about disguised as merchantmen.
 “ 412—Proceed on your voyage.

significations indicated.



You are running into danger.



Fire or leak; want immediate assistance.



Short of provisions; starving.



Aground; want immediate assistance.

SEE GENERAL TABLE FOR SIGNAL ILLUSTRATIONS.

FLASH SIGNALS WITH LANTERN, HELIOGRAPH, OR SEARCH LIGHT.

Use short flash for “1,” two short flashes in quick succession for “2,” and a long steady flash for “3.” The elements of a letter should be slightly longer than in sound signals.

To call a vessel, make the initial letter of her name until acknowledged. Then turn on a steady flash until answered by a steady flash. Then proceed with the message.

All other conventional signals are the same as with the flag.

SOUND SIGNALS WITH FOG WHISTLE, FOG HORN, OR BUGLE.

Use one toot (about half second) for “1,” two toots (in quick succession) for “2,” and a blast (about two seconds' long) for “3.” The ear and not the watch is to be relied upon for the intervals.

The signal of execution for all tactical or drill signals will be one long blast followed by two toots in quick succession.

In the use of any other appliance, such as a bell, by which a blast can not be given, three strokes in quick succession will be given in the place of the blast to indicate “3.”

When more than two vessels are in company, each vessel, after making “I understand,” should make her call letter that it may be certain which vessel has acknowledged.

UNITED STATES NAVY SIGNAL CODE.

A	2 2	H	1 2 2	O	2 1	V	1 2 2 2
B	2 1 1 2	I	1	P	1 2 1 2	W	1 1 2 1
C	1 2 1	J	1 1 2 2	Q	1 2 1 1	X	2 1 2 2
D	2 2 2	K	2 1 2 1	R	2 1 1	Y	1 1 1
E	1 2	L	2 2 1	S	2 1 2	Z	2 2 2 2
F	2 2 2 1	M	1 2 2 1	T	2	tion	1 1 1 2
G	2 2 1 1	N	1 1	U	1 1 2		

NUMERALS

1	1 1 1 1	3	1 1 1 2	5	1 1 2 2	7	1 2 2 2	9	1 2 2 1
2	2 2 2 2	4	2 2 2 1	6	2 2 1 1	8	2 1 1 1	0	2 1 1 2

ABBREVIATIONS

a	after	c	can	n	not	t	the	ur	your	wi	with
b	before	h	have	r	are	u	you	w	word	y	yes
	x x 3	"numerals follow" or "numerals end."									
	sig. 3.	"signature follows."									

CONVENTIONAL SIGNALS

End of a word	3	Repeat after (word)	121.121.3.223 (word)
End of a sentence	33	Repeat last word	121.121.333
End of a message	333	Repeat last message	121.121.121.333
Error	12.12.3	Move a little to right	211.211.3
Acknowledgement or, "I understand"	22.22.3	Move a little to left	221.221.3
Cease signaling	22.22.22.333	Signal faster	2212.3
Wait a moment	1111.3		

INSTRUCTIONS FOR USING THE SYSTEM.

The whole number opposite each letter or numeral stands for that letter or numeral.

TO SEND A MESSAGE.

"To call" a vessel, signal the initial letter of her name until acknowledged. To acknowledge a call or receipt of a message, signal "I understand."

Make a slight pause after each letter and also after "front." If the sender discovers that he has made an error, he should make the "front" and "12.12.3," after which he proceeds with the message, beginning with the word in which the error occurred.

TO SIGNAL WITH FLAG, TORCH, HAND LANTERN, OR BEAM OF SEARCH LIGHT.

There are but one position and three motions.

The first position is with the flag or other appliance held vertically, the signalman facing squarely towards the person to whom he is signaling.

In the first motion, "one" or "1," the signal is waved to the right of the sender and embraces an arc of 90 degrees, starting with a vertical and returning to it, and will be made in a plane exactly at right angles to the line connecting the two stations.

The second motion, "two" or "2," is a similar motion to the left of the sender.

To make the third motion, "front" or "three" or "3," the signal is waved to the ground directly in front of the sender, and instantly returned to the first position.

Numbers which occur in the body of the message must be spelled out in full.

To use the torch or hand lantern, a footlight must be used as a point of reference to the motion. The lantern is more conveniently swung out upwards by hand, from the footlight for "1" and "2" and raised vertically for "3."

WIG-WAG SIGNAL CODE.

Signaling by wig-wag is carried on by waving in certain defined ways, a flag fastened to a staff, represented by the figures 1, 2 and 3, and thus letters are made and words spelled.

There are two wig-wag flags, one a square white flag with a red square in the centre, and the other a square red flag with a white square in the centre.

But one flag is used in signaling, and that one is selected which can be easier seen against the flagman's background.



FIGURE 1



FIGURE 2



FIGURE 3

FLAG WAVING.

Instructions for Communicating by Flashing Signals with a Flag (Generally Termed Flag Waving).

The system used is the Morse Alphabet, the letters being made by groups of Long and Short flashes caused by moving a flag through a long or short arc, as described below.

The signalman may work from left to right, or from right to left, as shown in figures 1 and 2, according to convenience and direction of the wind.

In the normal position (a) in the above figures, the flag should make an angle of 25 degrees with a vertical line through the center of the body.

The pole should be kept high enough to permit seeing underneath the flag while in motion.

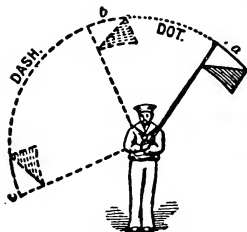































FIGURE 1.



FIGURE 2.

BRITISH WIG-WAG SIGNALS.

SIGNS.						
Alphabetical Signification.	A	B	C	D	E	F
Numeral Signification.	1	2	3	4	5	6
SIGNS						
Alphabetical Signification.	G	H	I	J	K	L
Numeral Signification.	7	8	9	ALSO ALPHABETICAL SIGN.	0	
SIGNS.						
Alphabetical Signification.	M	N	O	P	Q	R
SIGNS.						
Alphabetical Signification.	S	T	U	V	W	X
SIGNS.						
Signification.	Y	Z		ALPHABETICAL.	NUMERAL.	ANNUL.

HELP IN CASE OF ACCIDENTS

GENERAL DIRECTIONS FOR RENDERING FIRST AID.

Be calm and collected.

In any case don't get excited.

Send at once for a doctor, telling him the character of the illness or injury.

Give the patient plenty of air. Keep the crowd back.

The best position for the patient is on the back with the head low. Never raise the head more than necessary to put a small pillow, such as a folded coat, under it. With a flushed face the head may be raised to this extent. With a pale face it should not be raised at all.

If the patient is vomiting, he should be placed on his side, or his head turned to one side, so that the matter vomited will not go into his windpipe and choke him.

Unconscious patients cannot swallow, therefore never try to give them water or stimulants.

Fainting. Place flat on back; allow fresh air and sprinkle with water. Place head lower than rest of body.

Tight clothing interferes with breathing and circulation. Clothing should be loosened at once. If necessary to remove the clothing, slit up the nearest seam in the outer clothing first and cut or tear the under clothing. The sound side should be undressed first, so that the injured side will be subject to less moving. When necessary to remove boots or shoes they should be freely cut.

WOUNDS.—The object of dressing a wound is to keep dirt from getting into it. For this purpose First Aid Packages containing a clean sterile pad of absorbent gauze should be obtained. The wrappings should be removed and the pad applied over the wound without touching the fingers either to the pad or to the wound. Open the package, take hold of the sterile gauze on one side, place the other side, which has not been touched, against the wound and bind it in place.

FRACTURES.—A simple fracture is where the bone is broken and the skin is whole. The object of treatment of a fracture is to prevent further injury, especially puncture of the skin by the sharp edges of the broken bone. If this occurs, simple fracture is converted into a compound fracture—a much more serious condition. If a doctor is expected soon, support the broken bone by pillows or folded coats, taking care that it is not bent at the point of fracture. The patient should be moved as little as possible. If it is necessary to move the patient, fasten on a splint, reaching from well above the site of the break to well below it. A splint can be made out of anything stiff—a piece of board, a wire gauze, branch of a tree, etc.

A broken arm should be supported by a sling.

In case of a compound fracture the wound should be treated with a First Aid Dressing, as above, and then the fracture should be treated as detailed under Fractures.

SPRAINS.—A sprain is an injury to a joint, with laceration of its ligaments. An elastic bandage should be applied as soon as possible.

Hemorrhage. The usual treatment is rest in the recumbent position; small pieces of ice should be freely swallowed, and the application of ice wrapped in a towel, or in an ice-bag, or snow, cold water, etc., over the stomach; hot applications may be applied to the extremities.

HEMORRHAGE OR BLEEDING.—Bleeding from a wound can usually be controlled by pressure applied directly to the wound. The pad in a First Aid Package, therefore, can be bound tightly over the injured place. If the bleeding is excessive and the blood comes in spurts, it can be controlled by a tourniquet of rubber tubing, or even a twisted handkerchief, placed nearer to the heart than to the injury, and pulled as tight as possible about the limb. If the bleeding continues the tourniquet is not tight enough. Unless the patient is hours away from a doctor, the tourniquet may be left in place until the doctor arrives.

CONVULSIONS.—Place anything hard between the teeth to prevent biting of the tongue (a piece of wood, a jack-knife, or a handkerchief rolled up). Lay the patient down. Loosen clothing, particularly about the neck and waist. Do not attempt to move patient for some time after convulsion.

TREATMENT OF FROST-BITE.

Frost-bite is the result of exposure to severe cold. The vitality of the part affected is reduced to a very low point, loses its natural color, and becomes blue or purple.

TREATMENT.—Bring about reaction gradually by friction. Place the patient in a room without a fire, and avoid heat. Rub the part with snow or other cold application, and administer brandy and water carefully in small quantities. If a person is found insensible from cold, he must be kept away from the heat. Remove the clothing, and rub thoroughly with snow or cloths wrung out in cold water. Continue the friction, especially to the extremities, until signs of recovery appear. Artificial respiration may be necessary. Give brandy and beef tea in small quantities.

INTOXICATION.

Notice the odor of the breath. Lay the individual on his side on a bed, with his head raised. The patient should be induced to vomit. Stimulants should be avoided.

APOPLEXY.

Cold should be applied to the head, which should be kept well raised. Clothing removed from the neck and chest. Stimulants avoided.

SUNSTROKE.

Sunstroke. Loosen clothing. Get patient into shade and apply ice-cold water to head. Keep head in elevated position.

Ice should be applied freely to the head, and the body may also be bathed in cold water until the fever subsides.

Burns and Scalds. Cover with cooking soda, and lay wet cloths over it. Whites of eggs and olive oil. Olive oil or linseed oil, plain or mixed with chalk and whiting. Sweet or olive oil and lime water.

FIRE.

1. Send for medical aid; let the sufferer be put to bed as quickly as possible; remove all remains of clothing about the injured parts, cutting with extreme caution, as it is of the first importance to avoid tearing the skin or breaking a blister. If this is not attended to, the future danger will be greatly aggravated. If possible to avoid it, the water must not be let out of the blister.

2. As the readiest thing at hand, cover all the injured parts tenderly with clean cotton or wool, what is commonly known as wadding; the cleaner and purer, the better (the best for the purpose is kept by druggists). It relieves by excluding the air. Linen rag, soaked in a mixture of equal parts of lime-water and linseed oil, also forms a good dressing. Common whiting is also very good, applied wet and continually damped with a sponge.

3. It is better to avoid cold applications; they certainly allay pain, but, unless the cold be maintained, the momentary relief is followed by a considerable aggravation of the suffering. In extensive burns, moreover, cold water freely applied is not unattended by danger.

4. From thirty-six to fifty hours after the injury the blisters will present a milky appearance, and show surrounding inflammation; when this is the case, they may be opened with the point of a large needle. Dressing for burns may then be simple wax and oil spread on lint; but so much depends on circumstances and the state of health of the sufferer, that it is desirable as soon as possible to secure medical attendance.

5. To recover a person in a state of insensibility from the effect of smoke, dash cold water in the face, or cold and hot water alternately. Should this fail, turn him on his face, with his arms folded under his forehead. Apply pressure along the back and ribs, and turn the body gradually on the side, then again slowly on the face, repeating the pressure on the back. Persevere with these alternate rolling movements about sixteen times in a minute, until respiration is restored. A warm bath will now complete the recovery.

Fire in a Building. Crawl on the floor. The clearest air is the lowest in the room. Cover head with woolen wrap, wet if possible. Cut holes for the eyes.

POISONING.

In all cases of poisoning, first empty the stomach by giving large drinks of warm water, with a tablespoonful of mustard or salt to a pint; or by tickling the throat with your finger or a feather.

If the poison taken is Opium, Laudanum or Morphine—which kill by putting the patient to sleep—keep him awake by walking him around, slapping him, rubbing him, etc. Give strong coffee until the doctor comes.

If the poison is of an irritating nature, as Arsenic, Rough on Rats, Corrosive Sublimate, Carbolic Acid—give large drinks of milk, flour and water, or whites of eggs, or sweet or olive oil.

If the poison is strong acid, as Sulphuric or Nitric Acid, scrape plaster from the wall and make lime-water of it, and make the patient drink that, in addition to the whites of eggs or milk, etc., spoken of before.

If the poison is Caustic Potash, give lemon juice or vinegar.

GAS POISONING.

Turn off the gas. Open the windows. Bring the patient as near as possible to the window or into the open air. If the patient does not breathe begin artificial respiration. In extreme cases the administration of oxygen, if available, is of service.

Drowning. 1. Loosen the clothing, if any. 2. Empty lungs of water by laying body on its stomach and lifting it by the middle so that the head hangs down. Jerk the body a few times. 3. Pull the tongue forward, using handkerchief, or pin with string, if necessary. 4. Imitate motion of respiration by alternately compressing and expanding the lower ribs about twenty times a minute. Alternately raising and lowering the arms from the sides up above the head will stimulate the action of the lungs. Let it be done gently, but persistently. 5. Apply warmth and friction to extremities. 6. By holding tongue forward, closing the nostrils and pressing the "Adam's apple" back (thus closing entrance to stomach), direct inflation may be tried. Take a deep breath and breathe it forcibly into the mouth of patient, compress the chest to expel the air, and repeat the operation.

7. **DON'T GIVE UP!** People have been saved after HOURS of patient, vigorous effort. 8. When breathing begins, get patient into warm bed, give WARM drinks, or spirits in teaspoonfuls, fresh air and quiet.

APPEARANCES WHICH GENERALLY INDICATE DEATH.

There is no breathing nor heart's action; the eyelids are generally half-closed; the pupils dilated; the jaws clenched; the fingers semi-contracted; the tongue appearing between the teeth, and the mouth and nostrils are covered with a froth. The skin of the arms and thighs shows the appearance known as goose-flesh. Coldness and pallor of surface increase.

The treatment recommended by the Society is to be persevered in for three or four hours. It is an erroneous opinion that persons are irrecoverable because life does not soon make its appearance, as cases have had a successful result even after five hours' perseverance; and it is absurd to suppose that a body must not be meddled with or removed without permission of a coroner or medical examiner.

DIRECTIONS

FOR RESCUING DROWNING PERSONS.

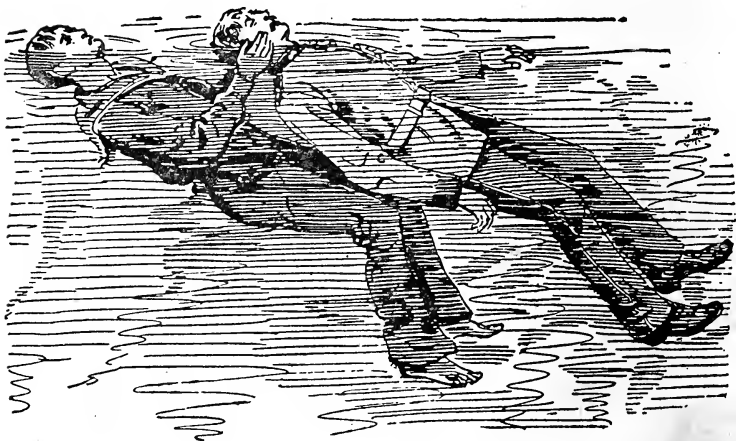

THE BEST METHOD WHEN THERE IS NO STRUGGLING.

Provided the drowning person does not struggle, turn him on his back, place your hands on either side of his face. Then turn on your back, hold him in front of you, and swim with the back stroke, taking care to keep his face above the surface of the water.

Remember that it is most important to keep the face of the drowning person above the surface of the water. Avoid all jerking, struggling or tugging, but swim with a regular, well-timed kick of the legs, husbanding the strength for continued effort.

THE BEST METHOD FOR ONE WHO STRUGGLES.

When the drowning person is struggling, and difficult to manage, turn him on his back, and take a firm hold of his arms just above the elbows. Draw the arms upward at right angles to the body and swim with the back stroke. This hold will put the drowning person under the control of the rescuer, who can prevent him from turning round or clutching.



When carrying a struggling person on the surface of the water it will be of advantage to keep the elbows well out from the sides, as this expands the chest, inflates the lungs and adds to his buoyancy. The legs should be kept well up to the surface, the body being as horizontal as possible.

THE BEST METHOD FOR ONE WHO STRUGGLES VIOLENTLY.

If the arms be difficult to grasp or the struggling so violent as to prevent a firm hold, slip your hands under the armpits of the drowning person and place them on his chest or round his arms. Raise them at right angles to the body, thus placing the drowning person completely in your power. Then turn on your back and swim with the back stroke.



Rescuers should at all times be governed by circumstances, using their judgment which method to adopt in conveying the drowning person to shore, taking care to avoid wasting their strength hopelessly against tide or stream—always float or swim with it and gradually make for shore, or wait until a boat or other help arrives.

HOW TO EFFECT A RELEASE IF CLUTCHED.

IF CLUTCHED BY THE WRISTS.

If the rescuer be held by the wrists, turn both arms simultaneously against the drowning person's thumbs, outward, and bring the arms at right angles to the body. thus dislocating the thumbs of the drowning person if he does not let go.



IF CLUTCHED ROUND THE NECK.

If clutched round the neck, take a deep breath, lean well over the drowning person. immediately place one hand in the small of his back and pass the other over on to his face; with the thumb and forefinger pinch the nostrils close, at the same time place the palm of the hand on the chin and push away with all force possible.



HOW TO HELP IN CASE OF CRAMP, ETC.

An easy method of assisting a tired swimmer or one attacked by cramp, as well as others who may be quiet. The person being assisted must place both hands on the shoulders of the rescuer with the arms at full stretch, and lie upon the back. The rescuer being uppermost, and having arms and legs free, swims with the breast stroke.

(The foregoing directions are copied from the Handbook of Instructions of the Royal Life Saving Society.)

DIRECTIONS

FOR RESTORING PERSONS APPARENTLY DEAD FROM DROWNING.



Fig. 1.

RULE 1. Unless in extreme cold weather, when there may be danger of freezing, do not move the patient, but instantly expose the face to a current of cold air, wipe dry the mouth and nostrils, rip the clothing so as to expose the chest and waist, and give two or three quick smarting slaps on the stomach and chest with the open hand. If the patient does not revive, proceed at once as follows:

RULE 2. TO DRAW OFF THE WATER FROM THE STOMACH AND LUNGS.—Turn the patient on his face, place a large roll of clothing beneath the stomach and press heavily on the back and spine over it for half a minute, or so long as fluids flow freely from the mouth. (Fig. 1.)

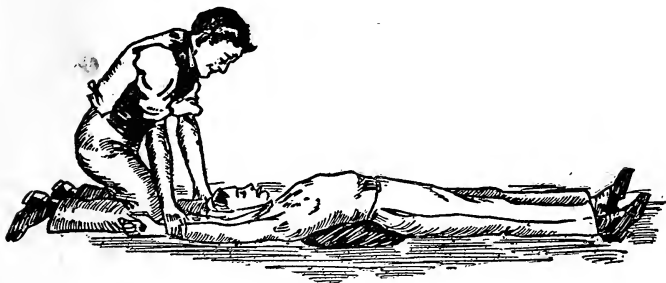

Fig. 2.

RULE 3. TO PRODUCE RESPIRATION.—If no assistance is at hand and you must work alone, place the patient on his back with the shoulders slightly raised on a folded article of clothing. Draw forward the tongue and keep it projecting beyond the lips. If the lower jaw be raised, the teeth may be made to hold the tongue in place; it may be necessary to retain the tongue by tying a handkerchief under the chin and over the head. Grasp the arms just below the elbows, and draw them steadily upward until they nearly meet above the head. (This enlarges the capacity of the chest and induces inspiration.) (Fig. 2.) Next, lower the arms to the side, and press firmly downward and inward and backward on the sides and front of the chest, over lower ribs and sternum. (This produces expiration.) (Fig. 3.)

Repeat these measures deliberately and perseveringly twelve to fifteen times in every minute. Occasionally rub the limbs upward from the extremities toward the heart, and dash cold water in the face.

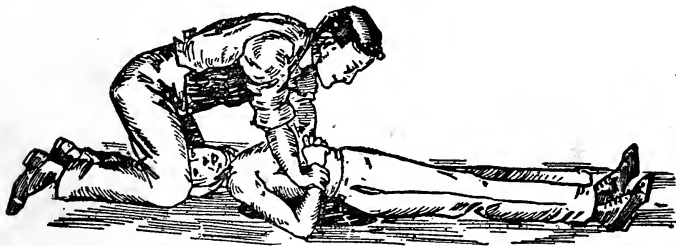

Fig. 3.

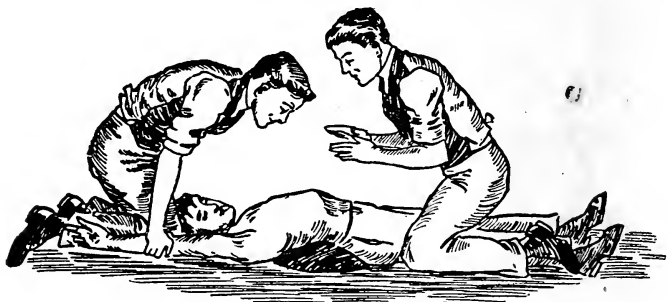

Fig. 4.

RULE 4. If an assistant is at hand, and two can work together, have one kneel at the patient's head and one astride the hips of the patient facing the patient's face. (Fig. 4.) Proceed as given above, save that when the operator at the head lowers the arms to the sides, the second operator presses on the sides and front of the chest backwards and downwards, throwing all his weight into it. (Fig. 5.) The method followed by two workers is the same as that by one, save that the second operator applies the pressure on the chest, and during the time the arms are being raised applies friction and warmth to the body.

RULE 5. Send for medical aid, stimulants and warm blankets and clothing as soon as possible.

RULE 6. Keep up the efforts for fully two hours, or until the patient breathes.

RULE 7. Practice drying and rubbing from the beginning in so far as possible without interfering with the movements of artificial respiration.

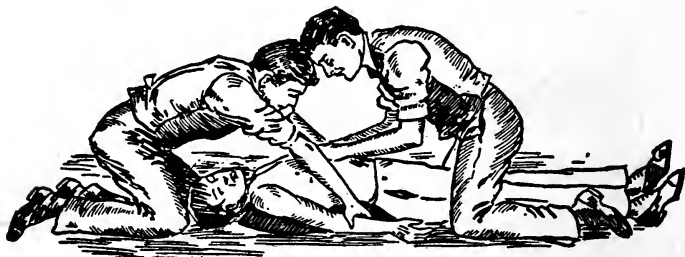

Fig. 5.

RULE 8. AFTER-TREATMENT.—As soon as the breathing is established, have the patient stripped of all wet clothing, wrapped in blankets only, put to bed comfortably warm but with a free circulation of fresh air, and left to perfect rest. Give a little brandy, hot water or other stimulant at hand, internally, every ten or fifteen minutes for the first hour, and as often after as necessary.

(The foregoing directions are copied from chart issued by The Humane Society of the Commonwealth of Massachusetts.)

THE SCHAFFER PRONE PRESSURE METHOD OF ARTIFICIAL RESPIRATION.

The following new method of resuscitation is added to the older methods which precede, on account of its alleged efficacy and its apparent greater simplicity. It requires only one operator.

The most important of the principles concerned in any method of artificial respiration is the elasticity of the lungs and thorax. The more effectually this is brought into play the better the method of artificial respiration, other things being equal. This method is considered to be better than the former methods and is known as the Prone Pressure Method.



Fig. 1

FIG. 1.—First position of operator and patient for effecting artificial respiration by the "prone pressure method" described by Professor Schaffer. The operator's hands are over the lowest ribs of the patient.

The patient lies prone on the abdomen, with the face turned to one side and the mouth clear. The operator kneels or squats by the side or opposite the patient, places his hands over the lowest ribs and sways his body forward and backward so as to allow his weight alternately to fall vertically on the wrists and to be removed. Hardly any muscular exertion is required. The pressure is exerted gradually and slowly, occupying about three seconds. It is then removed during two seconds, and again applied, and so on, about twelve times a minute. In this way an air exchange of 6,000 c. c., which is more than the average normal amount, is usually obtained. The positions of relaxation and of pressure are shown in the accompanying cuts. The advantages claimed for this method are: (1) That it is fully efficient; (2) that it can be performed without fatigue by a single individual; (3) that it is simple and easily learned; (4) that it allows the tongue to fall forward and the mucus and water to escape from the mouth so that the tendency of these to block the passage of air, which is inherent to the supine position, is altogether obviated.



Fig. 2

FIG. 2.—Second position of operator, who is throwing his weight vertically on his wrists, thus putting pressure on the thorax and abdomen of the patient. This pressure is exerted slowly, occupying some three seconds and is then removed for a period of two seconds and again applied.

INSTRUCTIONS FOR THE USE OF THE GUN AND ROCKET APPARATUS FOR SAVING LIFE FROM SHIPWRECK AS PRACTICED BY THE UNITED STATES COAST GUARD.

If your vessel is stranded and a shot with a small line is fired over it, get hold of the line and haul on board until you get a tail-block with an endless line rove through it; make the tailblock fast to the lower mast, well up, or in the event the masts are gone, to the best place to be found; cast off small shot line, see that rope in block runs free, and make a signal to shore. (Figure 1.)

A hawser will be bent to the endless line on shore and hauled off to your ship by the life-saving crew. Make hawser fast about two feet above the tailblock and unbend hawser from endless line. See that rope in block runs free and show signal to shore. (Figure 2.)

Life-savers on shore will then set hawser taut and by means of the endless line haul off to your ship a breeches buoy. (Figure 3.)

Figure 1

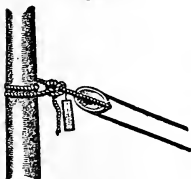

Figure 2

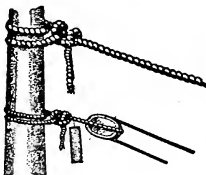
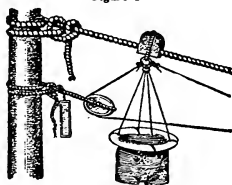

Figure 3



Let one man get clear into breeches buoy, thrusting his legs through the breeches; make signal to shore as before, and he will be hauled ashore by the life-savers and the empty buoy returned to the ship.

There should be on board every vessel a copy of detailed Instructions to Mariners in Case of Shipwreck, including wreck signals, etc., issued by the United States Coast Guard. A copy of the instructions may be secured by masters of vessels upon request addressed to the Captain Commandant, United States Coast Guard, Washington, D. C.

**INTRODUCTION TO REGULATIONS OF THE UNITED STATES
STEAMBOAT INSPECTION SERVICE GOVERNING
THE ISSUANCE OF OCEAN AND COAST-
WISE LICENSES.**

Opportunities open to American citizens for advancement in the world's best paid Merchant Marine will be many times greater, from now on, than ever before.

Competent American officers and seamen are required not merely for the duration of the war, but there will be positions for them in all the years to follow the war, for the United States will build and maintain a merchant marine in keeping with its position as a maritime nation.

The present time marks only the beginning of a new and important era in the American Merchant Marine, an era in which every man now being trained for the occupation of a seaman is destined to play his part.

The Government, through the Shipping Board, stands willing and anxious to train for advancement in its Merchant Marine every American seaman who will qualify himself for advancement.

Never before has the rapid advancement of competent American seamen depended almost wholly on their own willingness to advance in a profession that is at once, romantic, honorable, profitable, and absolutely necessary to the well-being of our country in war-time and in peace.

To encourage Americans to take to the sea and eventually rise to positions of responsibility in the Merchant Marine, the United States Steamboat Inspection Service has made provisions in its General Rules and Regulations whereby it is possible to obtain a license with a minimum amount of experience, less by far than is required by other maritime nations. These rules are incorporated in the Manual in order that interest may be aroused and the spur of ambition create the desire for promotion.

**SUBSTITUTING SERVICE IN NEXT LOWER GRADE
FOR RAISE OF GRADE**

20. Except as hereinafter provided, an applicant who has served in a lower grade than that for which he is licensed may substitute service in the grade next below that for which he is licensed, which service shall count one-half in computing experience for raise of grade. For example, if an applicant holds chief mate's license and has served 9 months as chief mate and 6 months as second mate, the 6 months' service as second mate shall count as 3 months as chief mate in computing experience.

AMENDMENTS OF ALL CLASSES OF GENERAL RULES AND REGULATIONS.

MASTER OF OCEAN STEAM VESSELS

21. An applicant for license as master of ocean steam vessels shall be eligible for examination after he has furnished satisfactory documentary evidence to the local inspectors that he has had the following experience:

First. One year's service as chief mate of ocean steam vessels, or

Second. Two years' service as second mate of ocean steam vessels, one year of such service while holding a license as chief mate of ocean steam vessels, or

Third. Two years' service as watch officers actually in charge of a bridge watch on ocean steam vessels, while holding a license as chief mate of ocean steam vessels, or

Fourth. Five years' service as third mate of ocean steam vessels, two years of such service while holding a license as chief mate of ocean steam vessels, or

Fifth. Five years' service on ocean sail vessels of 300 gross tons or over, two years of such service while holding a license as master of sail vessels, or

Sixth. One year's service as master or chief mate of coast-wise steam vessels.

Examination for Master of Ocean Steam Vessels

22. An applicant for license as master of ocean steam vessels shall pass a satisfactory examination as to his knowledge of the following subjects:

1. Latitude by meridian altitude of the sun.
2. Latitude by ex-meridian altitude of the sun.
3. Latitude by meridian altitude of a star.
4. Latitude by pole star.
5. Longitude by chronometer (a. m. and p. m.)
6. Position by Sumner's method.
7. Day's work.
8. Mercator's sailing.
9. Deviation of the compass by an amplitude.
10. Deviation of the compass by an azimuth.
11. Time of high water at a given port.
12. Chart navigation.
13. Storm signals.
14. International code of signals.
15. International rules for preventing collisions at sea.
16. Use of gun and rocket apparatus for saving life from shipwreck, as practiced by the United States Coast Guard.
17. Such further examination of a non-mathematical character as the local inspectors may require.

MASTERS OF COASTWISE STEAM VESSELS

23. An applicant for license as master of coastwise steam vessels shall be eligible for examination after he has furnished satisfactory documentary evidence to the local inspectors that he has had the following experience:

First. One year's service as chief mate of ocean or coastwise steam vessels, or

Second. Two years' service as second mate of ocean or coastwise steam vessels, one year of such service while holding a license as chief mate of ocean or coastwise steam vessels, or

Third. Five years' service as third mate of ocean or coastwise steam vessels, two years of such service while holding a license as chief mate of ocean or coastwise steam vessels, or

Fourth. One year's service as master of lake, bay, or sound steam vessels and in addition thereto one year's service as second mate, third mate, quartermaster or wheelsman on ocean or coastwise steam vessels while holding a license as master of lake, bay, or sound steam vessels, or

Fifth. Five years' service on ocean or coastwise sail vessels of 300 gross tons or over, two years of which service shall have been as master, or

Sixth. One year's service as a licensed master of ocean or coastwise sail vessels of 700 gross tons or over, or

Seventh. Two years' service as master of lake, bay, or sound towing steam vessels for license as master of coastwise towing steam vessels of 300 gross tons or under.

In cases where the experience of an applicant for license as master of coastwise steam vessels does not meet the specific requirements of this section, other service which the local inspectors consider a fair and reasonable equivalent may be accepted by them in lieu of the service herein specified.

Examination for Master of Coastwise Steam Vessels

24. An applicant for license as master of coastwise steam vessels on routes exceeding 300 miles shall pass a satisfactory examination as to his knowledge of the following subjects:

1. Latitude by meridian altitude of the sun.
2. Latitude by pole star.
3. Day's work.
4. Determination of distance from a fixed object.
5. Chart navigation.
6. International rules for preventing collisions at sea.
7. Storm signals.
8. Use of gun and rocket apparatus for saving life from shipwreck, as practiced by the United States Coast Guard.
9. Such further examination of a non-mathematical character as the local inspectors may require.

An applicant for license as master of coastwise steam vessels on routes not exceeding 300 miles shall pass a satisfactory examination as to his knowledge of the following subjects:

1. Chart navigation.
2. Aids to navigation on route.
3. Determination of distance from a fixed object.
4. International rules for preventing collisions at sea.
5. Storm signals.
6. Such further examination of a non-mathematical character as the local inspectors may require.

MASTERS OF SAIL VESSELS

25. An applicant for license as master of sail vessels of over 700 gross tons shall be eligible for examination after he has furnished satisfactory documentary evidence to the local inspectors that he has had the following experience:

First. Five years' service in the deck department of sail vessels of 200 gross tons or over, one year of such service shall have been as master of sail vessels of 500 gross tons or over, or

Second. Two years' service as master of sail vessels of 200 gross tons or over, or

Third. Two years' service as mate of sail vessels of 500 gross tons or over, or

Fourth. Two years' service as master of auxiliary sail vessels of 100 gross tons or over.

In cases where the experience of an applicant for license as master of sail vessels does not meet the specific requirements of this section, other service which the local inspectors consider a fair and reasonable equivalent may be accepted by them in lieu of the service herein specified.

Examination for License as Master of Sail Vessels

26. An applicant for license as master of sail vessels shall pass a satisfactory examination as to his knowledge of the following subjects:

1. Latitude by meridian altitude of the sun.
2. Latitude by pole star.
3. Longitude by chronometer (a. m. and p. m.).
4. Day's work.
5. Mercator's sailing.
6. Deviation of the compass by an amplitude.
7. Deviation of the compass by an azimuth.
8. Chart navigation.
9. International code of signals.
10. Storm signals.
11. International rules for preventing collisions at sea.
12. Use of gun and rocket apparatus for saving life from shipwreck, as practiced by the U. S. Coast Guard.
13. Such further examination of a non-mathematical character as the local inspectors may require.

CHIEF MATE OF OCEAN STEAM VESSELS

27. An applicant for license as chief mate of ocean steam vessels shall be eligible for examination after he has furnished satisfactory documentary evidence to the local inspectors that he has had the following experience:

First. One year's service as a licensed second mate of ocean or coastwise steam vessels, or

Second. Two years' service as watch officer on ocean or coastwise steam vessels, while holding license as second mate of ocean or coastwise steam vessels, or

Third. Two years' service as third mate of ocean or coastwise steam vessels, one year of such service while holding a license as second mate of ocean or coastwise steam vessels, or

Fourth. Two years' service as master of lake, bay, or sound steam vessels of 1,000 gross tons or over, or

Fifth. Five years' service in the deck department of ocean or coastwise sail vessels of 200 gross tons or over, two years of which service as chief mate of such ocean or coastwise sail vessels, or

Sixth. Two years' service in the deck department of steam vessels engaged in the ocean or coastwise fisheries, one year of such service to have been as master of such vessels, or

Seventh. Five years' service in the deck department of sail vessels engaged in the ocean or coastwise fisheries, two years of such service to have been as master of such vessels.

In cases where the experience of an applicant for license as chief mate of ocean steam vessels does not meet the specific requirements of this section, other service which the local inspectors consider a fair and reasonable equivalent may be accepted by them in lieu of the service herein specified.

SECOND MATE OF OCEAN STEAM VESSELS

28. An applicant for license as second mate of ocean steam vessels shall be eligible for examination after he shall have furnished satisfactory documentary evidence to the local inspectors that he has had the following experience:

First. One year's service as third mate of ocean or coastwise steam vessels, or

Second. Three years' service in the deck department of ocean or coastwise steam vessels, one year of such service shall have been as watch officer or quartermaster on such vessels, or

Third. A graduate from the seamanship class of a nautical school ship together with three months' service in the deck department of ocean or coastwise steam vessels, or

Fourth. Three years' service in the deck department of ocean or coastwise sail vessels of 200 gross tons or over, one year of such service shall have been as second mate of such vessels, or

Fifth. One year's service as quartermaster of ocean or coastwise steam vessels while holding a license as third mate of ocean or coastwise steam vessels, or

Sixth. Three years' service as a seaman in the deck department of ocean or coastwise sail vessels together with one year's service in the deck department of ocean or coastwise steam vessels, or

Seventh. Five years' service in the deck department of ocean or coastwise sail vessels of 100 gross tons or over. Service on sail vessels engaged in the ocean or coastwise fisheries shall be accepted as meeting the requirements of this paragraph, or

Eighth. One year's service as first-class pilot of lake, bay, or sound steam vessels of 500 gross tons or over, together with three months' service in the deck department of ocean or coastwise steam vessels, or

Ninth. One year's service as master of lake, bay, or sound steam vessels of 500 gross tons or over.

In cases where the experience of an applicant for license as second mate of ocean steam vessels does not meet the specific requirements of this section, other service which the local inspectors consider a fair and reasonable equivalent may be accepted by them in lieu of the service herein specified.

Examination for License as Chief Mate and Second Mate of Ocean Steam Vessels

29. An applicant for license as chief mate or second mate of ocean steam vessels shall be required to pass a satisfactory examination as to his knowledge of the following subjects:

1. Latitude by meridian altitude of the sun.
2. Latitude by meridian altitude of a star.
3. Longitude by chronometer (a. m. and p. m.)
4. Deviation of the compass by an amplitude.
5. Deviation of the compass by an azimuth.
6. Day's work.
7. Mercator's sailing.
8. Determination of distance from a fixed object.
9. Chart navigation.
10. Storm signals.
11. International code of signals.
12. International rules for preventing collisions at sea.
13. Stowage of cargo.
14. Use of gun and rocket apparatus for saving life from shipwreck, as practiced by the United States Coast Guard.
15. Such further examination of a non-mathematical character as the local inspectors may require.

THIRD MATE OF OCEAN STEAM VESSELS

30. An applicant for license as third mate of ocean steam vessels shall be eligible for examination after he has furnished satisfactory documentary evidence to the local inspectors that he has had the following experience:

First. Two years' service in the deck department of ocean or coastwise steam vessels, or

Second. Three years' service in the deck department of ocean or coastwise sail vessels, or

Third. A graduate from the seamanship class of a nautical school ship, or

Fourth. One year's service as master or pilot of lake, bay, or sound steamers.

In cases where the experience of an applicant for license as third mate of ocean steam vessels does not meet the specific requirements of this section, other service which the local inspectors consider a fair and reasonable equivalent may be accepted by them in lieu of the service herein specified.

Examination for License as Third Mate of Ocean Steam Vessels

31. An applicant for license as third mate of ocean steam vessels shall be required to pass a satisfactory examination as to his knowledge of the following subjects:

1. Latitude by meridian altitude of the sun.
2. Day's work.
3. Mercator's sailing.
4. Determination of distance from a fixed object.
5. Chart Navigation.
6. International rules for preventing collisions at sea.
7. Stowage of cargo.
8. Storm signals.
9. Such further examination of a non-mathematical character as the local inspectors may require.

CHIEF MATE OF COASTWISE STEAM VESSELS

32. An applicant for chief mate of coastwise steam vessels shall be eligible for examination after he has furnished satisfactory documentary evidence to the local inspectors that he has had the following experience:

First. One year's service as second mate of ocean or coastwise steam vessels, or

Second. One year's service as first-class pilot of lake, bay, or sound steam vessels, together with one year's service as quartermaster or wheelsman on ocean or coastwise steam vessels while holding a license as first-class pilot of lake, bay, or sound steam vessels, or

Third. Two years' service as third mate of ocean or coastwise steam vessels, or

Fourth. Two years' service in the deck department of steam vessels engaged in the ocean or coastwise fisheries, one year of such service to have been as master of such vessels, or

Fifth. Five years' service in the deck department of sail vessels engaged in the ocean or coastwise fisheries, two years' of such service to have been as master of such vessels, or

Sixth. Two years' service as master of ocean or coastwise sail vessels of 200 gross tons or over, or

Seventh. Three years' service in the deck department of ocean or coastwise steam vessels for license as chief mate of coastwise steam vessels of 500 gross tons or under, or

Eighth. Two years' service in the deck department of ocean or coastwise sail vessels together with one year's service in the deck department of ocean or coastwise steam vessels for license as chief mate of coastwise steam vessels of 500 gross tons or under, or

Ninth. One year's service as master or two years' service as first-class pilot of lake, bay or sound towing steam vessels for license as chief mate of coastwise towing steam vessels of 300 gross tons or under.

In cases where the experience of an applicant for license as chief mate of coastwise steam vessels does not meet the specific requirements of this section, other service which the local inspectors consider a fair and reasonable equivalent may be accepted by them in lieu of the service herein specified.

SECOND MATE OF COASTWISE STEAM VESSELS

33. An applicant for license as second mate of coastwise steam vessels shall be eligible for examination after he has furnished satisfactory documentary evidence to the local inspectors that he has had the following experience:

First. One year's service as third mate of ocean or coastwise steam vessels, or

Second. One year's service as quartermaster or wheelsman on ocean or coastwise steam vessels while holding a license as third mate of ocean or coastwise steam vessels, or

Third. Three years' service in the deck department of ocean or coastwise steam vessels, or

Fourth. Two years' service in the deck department of ocean or coastwise sail vessels together with one year's service in the deck department of ocean or coastwise steam vessels, or

Fifth. A graduate from the seamanship class of a nautical school ship together with three months' service in the deck department of an ocean or coastwise steam vessel, or

Sixth. One year's service as a licensed master of lake, bay, or sound steam vessels, or

Seventh. Two years' service as first-class pilot of lake, bay, or sound steam vessels, or

Eighth. One year's service as first-class pilot of lake, bay, or sound steam vessels, together with three months' service in the deck department of ocean or coastwise steam vessels, or

Ninth. One year's service as chief mate of ocean or coastwise steam vessels engaged in the fisheries, or

Tenth. One year's service as master of ocean or coastwise sail vessels engaged in the fisheries.

In cases where the experience of an applicant for license as second mate of coastwise steam vessels does not meet the specific requirements of this section, other service which the local inspectors consider a fair and reasonable equivalent may be accepted by them in lieu of the service herein specified.

THIRD MATE OF COASTWISE STEAM VESSELS

34. An applicant for license as third mate of coastwise steam vessels shall be eligible for examination after he has furnished satisfactory documentary evidence to the local inspectors that he has had the following experience:

First. Two years' service in the deck department of ocean or coastwise steam vessels, or

Second. Three years' service in the deck department of ocean or coastwise sail vessels, or

Third. A graduate from the seamanship class of a nautical school ship, or

Fourth. One year's service as master or first-class pilot of lake, bay, or sound steam vessels.

In cases where the experience of an applicant for license as third mate of coastwise steam vessels does not meet the specific requirements of this section, other service which the local inspectors consider a fair and reasonable equivalent may be accepted by them in lieu of the service herein specified.

Examination for License as Chief Mate and Second Mate of Coastwise Steam Vessels

35. An applicant for license as chief mate or second mate of coastwise steam vessels on routes exceeding 600 miles shall be required to pass a satisfactory examination as to his knowledge of the following subjects:

1. Latitude by meridian altitude of the sun.
2. Day's work.
3. Determination of distance from a fixed object.
4. International rules for preventing collisions at sea.
5. Chart navigation.
6. Stowage of cargo.
7. Storm signals.
8. Such further examination of a non-mathematical character as the local inspectors may require.

An applicant for license as chief mate or second mate of coastwise steam vessels on routes of 600 miles or less shall be required to pass a satisfactory examination as to his knowledge of the following subjects:

1. Chart navigation.
2. Aids to navigation on route.
3. Determination of distance from a fixed object.
4. Marking of lead line.
5. International rules for preventing collisions at sea.
6. Storm signals.
7. Such further examination of a non-mathematical character as the local inspectors may require.

Examination for License as Third Mate of Coastwise Steam Vessels

36. An applicant for license as third mate of coastwise steam vessels shall pass a satisfactory examination as to his knowledge of the following subjects:

1. Chart navigation.
2. Determination of distance from a fixed object.
3. International rules for preventing collisions at sea.
4. Marking lead line.
5. Storm signals.
6. Such further examination of a non-mathematical character as the local inspectors may require.

CLASSIFICATION OF ENGINEERS

CHIEF ENGINEER OF OCEAN STEAM VESSELS

34. An applicant for license as chief engineer of ocean steam vessels shall be eligible for examination after he has furnished satisfactory documentary evidence to the local inspectors that he has had the following experience:

First. One year's service as first assistant engineer of ocean or coastwise steam vessels, or

Second. One year's service as chief engineer of lake, bay, or sound steam vessels, or

Third. Two years' service as first assistant engineer of lake, bay, or sound steam vessels, or

Fourth. Two years' service as second assistant engineer of ocean or coastwise steam vessels, or

Fifth. Three years' service in the engine department of an ocean or coastwise steam vessel for license as chief engineer of ocean steam vessels of 500 gross tons or under.

In cases where the experience of an applicant for license as chief engineer of ocean steam vessels does not meet the specific requirements of this section, other service which the local inspectors consider a fair and reasonable equivalent may be accepted by them in lieu of the service herein specified.

FIRST ASSISTANT ENGINEER OF OCEAN STEAM VESSELS

An applicant for license as first assistant engineer of ocean steam vessels shall be eligible for examination after he has furnished satisfactory documentary evidence to the local inspectors that he has had the following experience:

First. One year's service as second assistant engineer of ocean or coastwise steam vessels, or

Second. One year's service as chief or first assistant engineer of lake, bay, or sound steam vessels, or

Third. Two years' service as third assistant engineer of ocean or coastwise steam vessels, or

Fourth. Three years' service as an apprentice to the machinist trade and engaged in the construction or repair of marine, stationary, or locomotive engines, together with one year's service in the engine department of ocean or coastwise steam vessels, or

Fifth. A graduate from the engineering class of a nautical school ship together with 6 months' service in the engine department of ocean or coastwise steam vessels, or

Sixth. A graduate in mechanical engineering from a duly recognized school of technology, together with 6 months' service in the engine department of ocean or coastwise steam vessels, or

Seventh. Two years' service as a locomotive or stationary engineer, together with one year's service in the engine department of ocean or coastwise steam vessels, or

Eighth. Two years' service as second assistant engineer of lake, bay or sound steam vessels, or

Ninth. Three years' service in the engine department of ocean or coastwise steam vessels, for license as first assistant engineer of ocean steam vessels of 1,000 gross tons or under.

In cases where the experience of an applicant for license as first assistant engineer of ocean steam vessels does not meet the specific requirements of this section, other service which the local inspectors consider a fair and reasonable equivalent may be accepted by them in lieu of the service herein specified.

SECOND ASSISTANT ENGINEER OF OCEAN STEAM VESSELS

An applicant for license as second assistant engineer of ocean steam vessels shall be eligible for examination after he has furnished satisfactory documentary evidence to the local inspectors that he has had the following experience:

First. One year's service as third assistant engineer of ocean or coastwise steam vessels, or

Second. Six months' service as chief engineer, first assistant engineer or second assistant engineer of lake, bay, or sound steam vessels, or

Third. One year's service as third assistant engineer of lake, bay, or sound steam vessels, or

Fourth. Three years' service as oiler, or water tender, or combined service of three years in these positions, on ocean or coastwise steam vessels, or

Fifth. A graduate from the engineering class of a nautical school ship together with 3 months' service in the engine department of ocean or coastwise steam vessels, or

Sixth. A graduate in mechanical engineering from a duly recognized school of technology, together with 3 months' service in the engine department of ocean or coastwise steam vessels, or

Seventh. Three years' service as an apprentice to the machinist trade and engaged in the construction or repair of marine, stationary, or locomotive engines, together with 6 months' service in the engine department of ocean or coastwise steam vessels, or

Eighth. One year's service as a locomotive or stationary engineer, together with 6 months' service in the engine department of ocean or coastwise steam vessels, or

Ninth. One year's service as a stationary engineer in full charge of a plant of not less than 1,000 horsepower.

In cases where the experience of an applicant for license as second assistant engineer of ocean steam vessels does not meet the specific requirements of this section, other service which the local inspectors consider a fair and reasonable equivalent may be accepted by them in lieu of the service herein specified.

THIRD ASSISTANT ENGINEER OF OCEAN STEAM VESSELS

An applicant for license as third assistant engineer of ocean steam vessels shall be eligible for examination after he has furnished satisfactory documentary evidence to the local inspectors that he has had the following experience:

First. Three years' service as fireman on ocean or coastwise steam vessels, or

Second. Two years' service as oiler, or water tender, or combined service of two years in these positions, on ocean or coastwise steam vessels, or

Third. Six months' service as chief or assistant engineer on lake, bay, or sound steam vessels, or

Fourth. One year's service as chief or assistant engineer of river steam vessels, or

Fifth. A graduate from the engineering class of a nautical school ship, or

Sixth. A journeyman machinist who has been engaged in the construction or repair of marine steam engines.

In cases where the experience of an applicant for license as third assistant engineer of ocean steam vessels does not meet the specific requirements of this section, other service which the local inspectors consider a fair and reasonable equivalent may be accepted by them in lieu of the service herein specified.

QUALIFICATIONS REQUIRED FOR LICENSE AS ENGINEER OF STEAM VESSELS AND LICENSE FORMS REQUIRED.

35. No person shall receive an original license as engineer or assistant engineer of ocean steam vessels who has not had the experience required by the foregoing section, or experience which is deemed by the local inspectors to be a fair and reasonable equivalent therefor. The examination for license as chief or assistant engineer of ocean steamers shall be such as to satisfy the local inspectors that the applicant is capable of meeting the requirements and performing the duties required by the grade of license for which he makes application. No original license shall be granted any engineer who can not read and write and who does not understand the plain rules of arithmetic. Licenses to engineers of ocean steam vessels shall be issued on Forms 876, chief engineer's license, and 877, assistant engineer's license, according to grades of chief and assistant engineers specified in Rule V.

NAUTICAL DICTIONARY

- ABACK.** The position of the sails when the wind presses their surface toward the mast, tending to force the vessel astern.
- ABAFT.** Toward the stern.
- ABEAM.** On the side of the vessel, amidships, or at right angles.
- ABOARD.** Within, on board the vessel.
- ABOUT.** To go on the opposite tack.
- ABREAST.** Alongside of. Side by side.
- A-COCK-BILL.** The position of the yards of a ship when they are topped up at an angle with the deck. The position of an anchor when it hangs to the cathead.
- ADRIFT.** Broken from moorings or fasts.
- AFLOAT.** Resting on the surface of the water.
- AFORE.** Forward. The opposite of abaft.
- AFT.** Near the stern.
- AGROUND.** Touching the bottom.
- AHEAD.** In the direction of the vessel's bow. Wind ahead is from the direction toward which the vessel's head points.
- AHULL.** When a vessel lies with her sails furled and her helm lashed alee.
- ALEE.** When the helm is in the opposite direction from that in which the wind blows.
- ALL-ABACK.** When all the sails are aback. (See Aback.)
- ALL HANDS.** The entire crew.
- ALL IN THE WIND.** When all the sails are shaking.
- ALOFT.** Above the deck.
- AMIDSHIPS.** In the centre of the vessel; either with reference to her length or to her breadth.
- ANCHOR.** An iron instrument which, when dropped to the bottom, holds the vessel.
- ANCHOR-WATCH.** (See Watch.)
- APEAK.** When the cable is hove taut so as to bring the vessel over her anchor.
- APRON.** A timber fixed behind the lower part of the stem above the fore end of the keel.
- ARM. YARD-ARM.** The extremity of a yard. Also, the lower part of an anchor, crossing the shank, and terminating in the flukes.
- ARMING.** A piece of tallow put in the cavity and over the bottom of a lead-line.
- ASTERN.** In the direction of the stern. The opposite of ahead.
- ATHWART.** Across.
Athwart-ships. Across the line of the vessel's keel.
Athwart-hawse. Across the direction of a vessel's head. Across her cable.
- ATHWART-SHIPS.** Across the length of a vessel. The opposite to fore-and-aft.
- ATRIP.** The position of the anchor when it is raised clear of the ground.
- AVAST.** To stop; "Avast heaving!"
- AWEATHER.** When the helm is put in the direction from which the wind blows.
- AWEIGH.** The same as atrip.
- AWNING.** A covering of canvas over a vessel's deck, or over a boat, to keep off sun or rain.

- AYE.** Yes; and is always used in lieu thereof at sea, as "Aye, aye, sir," meaning "I understand."
- BACK.** To back an anchor, is to carry out a smaller one ahead of the one by which the vessel rides, to take off some of the strain.
To back a sail, is to throw it aback. (See **Aback.**)
To back and fill, is to alternately back and fill the sails.
- BACKSTAYS.** Rigging running from the masthead to the vessel's side, slanting a little aft.
- BALANCE-REEF.** The closest reef, and makes the sail triangular, or nearly so.
- BALE.** To bale a boat, is to throw water out of her.
- BALLAST.** Heavy material, as iron, lead, or stone, placed in the bottom of the hold, to keep a vessel steady.
To freshen ballast, is to shift it. Shingle ballast is coarse gravel.
- BANK.** A boat is double banked when two oars, one opposite the other, are pulled by men seated on the same thwart.
- BAR.** A bank or shoal. Capstan-bars are heavy pieces of wood by which the capstan is worked.
- BARE-POLES.** The condition of a vessel when she has no sail set.
- BARGE.** A large double-banked boat, usually used by the commander of a vessel in the navy.
- BARK, OR BARQUE.** A three-masted vessel, having her fore and main masts rigged like a ship's, and her mizzen mast like the main mast of a schooner, with no sail upon it but a spanker, and gaff topsail.
- BARNACLE.** A shell-fish often found on a vessel's bottom.
- BATTENS.** Thin strips of wood put around the hatches, to keep the tarpaulin down. Also, put upon rigging to keep it from chafing. A large batten widened at the end, and put upon rigging, is called a scotchman.
Battens are often used on yachts on the leech of a mainsail to make it set flat.
- BEACON.** A post or buoy placed over a shoal or bank to warn vessels of danger. Also a signalmark on land.
- BEAMS.** Strong pieces of timber stretching across the vessel, to support the decks.
On the weather or lee beam, is in a direction to windward or leeward, at right angles with the keel.
On beam-ends. The situation of a vessel when turned over so that her beams are inclined toward the vertical.
- BEAR.** An object bears so and so, when it is in such direction from the person looking.
To bear down upon a vessel, is to approach her from the windward.
To bear a-hand. To make haste.
- BEARING.** The direction of an object from the person looking. The bearings of a vessel are the widest part of her below the plank-shear. That part of her hull which is on the water-line when she is at anchor and in her proper trim.
- BEATING.** Going toward the direction of the wind, by alternate tacks.
- BECALM.** To intercept the wind. A vessel to windward is said to becalm another. So one sail becalms another. A highland has the same effect.
- BECKET.** A piece of rope placed so as to confine a spar or another rope. A handle made of rope, in the form of a circle, the handle of a chest is called a becket.
- BEES.** Pieces of plank bolted to the outer end of the bowsprit, to reeve the foretopmast stays through.

- BELAY.** To make a rope fast by turns around a pin or coil, without hitching or seizing it.
- BEND:** To make fast.
To bend a sail, is to make it fast to the spar.
To bend a cable, is to make it fast to the anchor.
A bend, is a knot by which one rope is made fast to another.
- BENDS.** The strongest part of a vessel's side, to which the beams, knees, and foot-hooks are bolted. The part between the water's edge and the bulwarks.
- BERTH.** The place where a vessel lies. The place in which a person sleeps.
- BETWEEN DECKS.** The space between any two decks of a ship.
- BIBBS.** Pieces of timber bolted to the hounds of a mast, to support the trestle-trees.
- BIGHT.** The double part of a rope when it is folded. Any part of a rope may be called the bight, except the ends. Also, a bend in the shore, making a small bay or inlet.
- BILGE.** That part of the floor of a ship upon which she would rest if aground; being the part near the keel which is more in a horizontal than a perpendicular line.
Bilge ways. Pieces of timber bolted together and placed under the bilge, in launching.
Bilged. When the bilge is broken in.
Bilge Water. Water which settles in the bilge.
Bilge. The largest circumference of a cask.
- BILGEWAYS.** Timbers placed beneath a vessel when building.
- BILL.** The point at the extremity of a fluke of an anchor.
- BINNACLE.** A receptacle placed near the helm, containing the compass, etc.
- BITTS.** Perpendicular pieces of timber going through the deck, to secure ropes to. The cables are fastened to them, if there is no windlass. There are also bitts to secure the windlass, and on each side of the heel of the bowsprit.
- BITTER, OR BITTER-END.** That part of the cable which is abaft the bitts.
- BLADE.** The flat part of an oar which goes into the water.
- BLOCK.** A piece of wood with sheaves, or wheels, through which the running rigging passes, to add to the purchase.
- BLUFF.** A vessel which is full and square forward.
- BOARD.** The stretch a vessel makes upon one tack, when she is beating.
Stern-board. When a vessel goes stern foremost.
By the board. When the masts of a vessel fall over the side.
- BOAT-HOOK.** An iron hook with a long staff.
- BOATSWAIN.** A ship's officer who has charge of the rigging and who calls the crew to duty.
- BOBSTAYS.** Used to confine the bowsprit to the stem or cutwater.
- BOLSTERS.** Pieces of soft wood, covered with canvas, placed on the trestle-trees, for the eyes of the rigging to rest upon.
- BOLTS.** Cylindrical bars of iron, copper, or composition, used to secure the different parts of a vessel.
- BOLT-ROPE.** The rope which goes round a sail, and to which the canvas is sewed.
- BONNET.** An additional piece of canvas attached to the foot of a jib by lacings.
- BOOBY HATCH.** A raised small hatch.
- BOOM.** A spar used to extend the foot of a fore-and-aft sail or studdingsail.
- Boom-irons.** Iron rings on the yards, through which the studdingsail booms traverse.

- BOTTOMRY.** A term in marine law referring to mortgaging of ships.
- BOUND.** Wind-bound. When a vessel is kept in port by a head wind.
- BOW.** The rounded part of a vessel, forward.
- BOWER.** A working anchor, the cable of which is bent and reeved through the hawse-hole.
Best bower is the larger of the two bowers.
- BOWLINE.** A rope leading forward from the leech of a square sail, to keep the leech well out when sailing close-hauled. A vessel is said to be on a bowline, or on a taut bowline, when she is close-hauled.
- Bowline-bridle.** The span on the leech of the sail to which the bowline is toggled.
- BOWSE.** To pull upon a tackle.
- BOWSPRIT.** A large, strong spar, standing from the bows of a vessel.
- BOX-HAULING.** Wearing a vessel by backing the head sails.
- BOX.** To box the compass, is to repeat the thirty-two points of the compass in order.
- BRACE.** A rope by which a yard is turned about.
To brace a yard, is to turn it about horizontally.
To brace up, is to lay the yard more fore-and-aft.
To brace in, is to lay it nearer square.
To brace to, is to brace the head yards a little aback, in tacking or wearing.
- BRACKISH.** Half salt and half fresh water.
- BRAILS.** Ropes by which the foot or lower corners of fore-and-aft sails are hauled up.
- BRAKE.** The handle of a ship's pump.
- BREAK.** To break bulk, is to begin to unload.
To break ground, is to lift the anchor from the bottom.
To break shear, is when a vessel, at anchor, in tending, is forced the wrong way by the wind or current, so that she does not lie well to keep clear of her anchor.
- BREAKER.** A small cask containing water. **Breakers.** Waves broken by ledges or shoals.
- BREAST-FAST.** A rope used to confine a vessel broadside to a wharf, or to some other vessel.
- BREAST-HOOKS.** Knees in the forward part of a vessel, across the stern, to secure the bows.
- BREAST-ROPE.** A rope passed round a man in the chains, while sounding.
- BREECH.** The outside angle of a knee-timber. The after end of a gun.
- BREECHING.** A strong rope used to secure the breech of a gun to the ship's side.
- BRIDLE.** Spans of rope attached to the leeches of square sails to which the bowlines are made fast. **Bridle-port.** The foremost port, used for stowing the anchors.
- BRIG.** A square-rigged vessel, with two masts. An hermaphrodite brig is rigged on the foremast like a brig and on the mainmast like a schooner.
- BRING TO.** The act of stopping a sailing vessel by bringing her head up into the wind.
- BROACH-TO.** To slew round when running before the wind.
- BROADSIDE.** The whole side of a vessel.
- BROKEN-BACK.** When a vessel is so strained as to droop at each end.

- BUCKLERS.** Blocks of wood made to fit in the hawse-holes, or holes in the half-ports, when at sea. Those in the hawse-holes are sometimes called **hawse-blocks**.
- BULK.** The whole cargo when stowed.
Stowed in bulk, is when goods are stowed loose, instead of being stowed in casks or bags.
- BUNK.** Bed on board ship.
- BULK HEAD.** Strong partitions in the hold of a vessel at regular lengths, to prevent water filling all parts of the vessel in case of accident.
Temporary partitions of boards to separate different parts of a vessel.
- BULL.** A sailor's term for a small keg, holding a gallon or two.
- BULLS EYE.** A small piece of stout wood with a hole in the centre for a stay or rope to reeve through, without a sheave, and with a groove round it for the strap, which is usually of iron. Also, a piece of thick glass inserted in the deck to let in light.
- BULWARKS.** Wood work around a vessel, above deck, fastened to stanchions.
- BUM-BOATS.** Boats which lie alongside a vessel in port with provisions, fruit, etc., to sell.
- BUMPKIN.** Pieces of timber projecting from the vessel to board the fore tack to; also from each quarter, for the main brace-blocks.
- BUNT.** The middle of a sail.
- BUNTING.** Thin woolen stuff of which flags are made.
- BUNTLINES.** Ropes used for hauling up the body of a sail.
- BUOY.** A floating cask, or piece of wood, attached by a rope to an anchor, to show its position. Also, floated over a shoal, or other dangerous place as a beacon.
To stream a buoy, is dropping it into the water before letting go the anchor.
A buoy is said to watch, when it floats upon the surface of the water.
- BURGEE.** A small flag, either pointed or swallowtail.
- BURTON.** A tackle, rove in a particular manner.
A single Spanish burton has three single blocks, or two single blocks and a hook in the bight of one of the running parts.
A double Spanish burton has three double blocks.
- BUSH.** The center piece of a wooden sheave in a block.
- BUTT.** The end of a plank where it unites with the end of another.
Scuttle-butt. A cask with a hole cut in its bilge, and kept on deck to hold water.
- BUTTOCK.** That part of the convexity of a vessel abaft, under the stern, contained between the counter above and the after part of the bilge below, and between the quarter on the side and the stern-post.
- BY.** By the Head. When the head of a vessel is lower in the water than her stern. If her stern is lower, she is by the stern.
- CABLE.** A large, strong rope, made fast by the anchor, by which the vessel is secured. A cable is usually 120 fathoms in length.
- CABOOSE.** A house on deck, where the cooking is done. Commonly called the Galley.
- CALL.** Bos'n's call used for piping orders.
- CAMBER.** A curvature upwards.

- CAN-HOOKS.** Slings with flat hooks at each end, used for hoisting barrels or light casks, the hooks being placed round the chimes, and the purchase hooked to the centre of the slings.
- CANT-PIECES.** Pieces of timber fastened to the angles of fishes and side-trees, to supply any part that may prove rotten.
- CANT-TIMBERS.** Timbers at both ends of a vessel, raised obliquely from the keel.
- Lower Half Cants.** Those parts of frames situated forward and abaft the square frames or the floor timbers which cross the keel.
- CANVAS.** The cloth of which sails are made. No. 1 is the coarsest and strongest.
- CAP.** A thick, strong block of wood with two holes through it, one square and the other round, used to confine together the head of one mast and the lower part of the mast next above it.
- CAPSIZE.** To overturn.
- CAPSTAN.** A machine placed perpendicularly on the deck, used for heaving or hoisting.
- CARDINAL POINTS.** The four main points of compass.
- CAREEN.** To heave a vessel down upon her side. To lie over, when sailing on the wind.
- CARLINGS.** Pieces of timber running between the beams.
- CARRICK-BEND.** A kind of knot. Carrick bitts are the windlass bitts.
- CARRY-AWAY.** To break a spar, or part a rope.
- CARRY ON.** To carry all sail possible.
- CAST.** To pay a vessel's head off, in getting under way, on the tack she is to start upon.
- CAT.** The tackle used to hoist the anchor up to the cat-head. **Cat-block,** the block of this tackle.
- CAT-HARPIN.** An iron leg used to confine the upper part of the rigging to the mast.
- CAT-HEAD.** Large timbers projecting from the vessel's side, to which the anchor is secured.
- CAT'S-PAW.** A kind of hitch made in a rope. A light current of air on the surface of the water.
- CAULK.** To fill the seams of a vessel with oakum.
- CEILING.** The inside sheathing of a vessel.
- CHAFE.** To rub the surface. **Chafing-gear** is the stuff put upon rigging and spars to prevent chafing.
- CHAINS.** Strong links or plates of iron, the lower ends of which are bolted through the ship's side to the timbers. Their upper ends are secured to the bottom of the dead-eyes in the channels. The chain cable of a vessel is called familiarly her chain.
- Rudder-chains lead from the outer and upper end of the rudder to the quarters.
- CHAIN-PLATES.** Plates of iron bolted to the side of a ship, to which the chains and dead-eyes of the lower rigging are connected.
- CHAMFER.** To take off the edge, or bevel the plank.
- CHANNELS.** Broad pieces of plank bolted edgewise to the outside of a vessel. Used in narrow vessels for spreading the lower rigging.
- CHARTER PARTY.** A contract in marine law.
- CHECK.** To stop or impede, as to check the cable from paying out.
- CHEEKS.** The projections on each side of a mast, upon which the trestle-trees rest. The sides of the shell of a block.

- CHIMES.** The ends of the staves of a cask, where they come out beyond the head of the cask.
- CHINSE.** To drive oakum into seams.
- CHIPS.** Nickname for ship's carpenter.
- CHOCKS.** Wedges used to secure anything with, or to rest upon. The long boat rests upon two chocks, when it is stowed.
- Chock-a-block.** When the lower block of a tackle is run close up to the upper one, so that you can hoist no higher. This is also called **two-blocks**.
- CISTERN.** An apartment in the hold of a vessel, having a pipe leading out through the side, with a sea-cock, by which water may be let in.
- CLAMPS.** Thick planks on the inside of vessels, to support the ends of beams.
- CLAWING OFF.** To work off close-hauled from lee shore.
- CLEAT.** A piece of wood used in different parts of a vessel to belay ropes to.
- CLEW.** The lower corner of square sails, and the after corner of fore-and-aft sails.
- CLEWLINE.** A rope that hauls up the clew of a square sail.
- CLINCH.** A half-hitch, stopped to its own part.
- CLOSE-HAULED.** When a vessel is sailing as close to the wind as she will go.
- CLOSE-REEFED.** When all the reefs are taken in.
- CLOVE-HITCH.** Two half-hitches round a spar or other rope.
- CLOVE-HOOK.** An iron clasp, in two parts, moving upon the same pivot, and overlapping.
- CLUBBING.** Drifting down a current with an anchor out.
- COAL TAR.** Tar made from bituminous coal.
- COAMINGS.** Raised work around the hatches, to prevent water going into the hold.
- COAT.** Mast-coat is a piece of canvas, tarred or painted, placed around a mast or bowsprit, where it enters the deck to keep out water.
- COCK-BILL.** To cock-bill a yard or anchor. (See **A-cock-bill**.)
- COCK-PIT.** An apartment in a vessel of war, used by the surgeon during an action.
The standing room of a yacht.
- CODE SIGNALS.** Flag signals for speaking at sea.
- CODLINE.** An eighteen thread line.
- COIL.** To lay a rope up in a circle, with one turn or fake over another.
A coil is a quantity of rope laid up in this manner.
- COLLAR.** An eye in the end or bight of a shroud or stay, to go over the mast-head.
- COLLIER.** A vessel used in coal trade.
- COMPANION.** A wooden covering over the staircase to a cabin.
Companion-way, the staircase to the cabin. **Companion-ladder.** Leading from the poop to the main deck.
- COMPASS.** The instrument which shows the course of a vessel.
- COMPOSITE.** A vessel with iron or metal frame and wooden skin.
- CONNING, or CUNNING.** Directing the helmsman in steering a vessel.
- CORINTHIAN.** Amateur.
- COUNTER.** That part of a vessel between the bottom of the stern and the wing-transom and buttock. **Counter-timbers** are short timbers put in to strengthen the counter.
- COURSES.** The common term for the sails that hang from a ship's lower yards. The foresail is called the **fore course** and the mainsail the **main course**.

- COXSWAIN.** The person who steers a boat and has charge of her.
- CRAB.** To catch a crab is to catch the oar in the water by feathering it too soon.
- CRADLE.** A frame to hold a vessel upright when hauling her up.
- CRAFT.** A general term applied to any collection of small vessels.
- CRANES.** Pieces of iron or timber at the vessel's sides, used to stow boats or spars upon. A machine used for hoisting.
- CRANK.** A vessel which is inclined to lean over a great deal and cannot bear much sail.
- CRANSE IRON.** A cap or ring at end of bowsprit.
- CREEPER.** An iron instrument, with four claws, used for dragging the bottom of a harbor or river.
- CRINGLE.** A short piece of rope with each end spliced into the bolt-rope of a sail confining an iron ring or thimble.
- CROSS-BARS.** Round bars of iron, bent at each end, used to turn the shank of an anchor.
- CROSS-JACK.** The cross-jack yard is the lower yard on the mizzen mast.
- CROSS-PAWLS.** Pieces of timber that keep a vessel together while in frame.
- CROSS-PIECE.** A piece of timber connecting two bits.
- CROSS-SPALES.** Pieces of timber placed across a vessel, and nailed to the frames, to keep the sides together until the knees are bolted.
- CROSS-TREES.** Pieces of oak supported by the cheeks and trestle-trees at the mast-heads, to sustain the tops on the lower mast, and to spread the rigging at the topmast-head.
- CROW-FOOT.** A number of small lines rove through the evrou to suspend an awning by.
- CROWN** of an anchor, is the place where the arms are joined to the shank.
To crown a knot, is to pass the strands over and under each other above the knot.
- CRUTCH.** A knee or piece of knee-timber, placed inside of a vessel to secure the heels of the cant-timbers abaft. Also the chock upon which the spanker-boom rests when the sail is not set.
- CUCKOLD'S NECK.** A knot by which a rope is secured to a spar, the two parts of the rope crossing each other, and seized together.
- CUDDY.** A cabin in the fore part of a boat.
- CUT-WATER.** The foremost part of a vessel's bow, which projects forward of the bows.
- CUTTER.** A small boat. Also, a kind of sloop.
- DAVY JONES.** The Spirit of the sea.
Davy Jones' Locker is the bottom of the sea.
- DAVITS.** Pieces of timber or iron, with sheaves or blocks at their ends, projecting over a vessel's sides or stern, to hoist up boats. Also, a spar with a roller or sheave at its end, used for fishing the anchor, called a fish-davit.
- DEAD EYE.** A circular block of wood, with holes through it, for the lanyards of rigging to reeve through, without sheaves, and with a groove round it for an iron strap.
- DEAD-LIGHTS.** Ports placed in the cabin windows.
- DEAD RECKONING.** A reckoning kept by observing a vessel's courses and distances by the log.
- DEAD-RISING, or RISING-LINE.** Those parts of a vessel's floor, throughout her length, where the floor-timbers terminate upon the lower futtock.

- DEAD-WATER.** The eddy under a vessel's counter when in motion.
- DEAD-WOOD.** Blocks of timber, laid upon each end of the keel, where the vessel narrows.
- DECK.** The planked floor of a vessel, resting upon the beams.
- DECK-STOPPER.** A stopper used for securing the cable forward of the windlass or capstan, while it is being overhauled.
- DEEP-SEA-LEAD.** The lead used in sounding at great depths.
- DEPARTURE.** The easting or westing made by a vessel. The bearing of an object on the coast from which a vessel commences dead reckoning.
- DERELICT.** A vessel forsaken on the high seas.
- DERRICK.** A single spar, supported by stays and guys, to which a purchase is attached, used to unload vessels, and for hoisting heavy objects.
- DINGHY.** A small open boat.
- DISPLACEMENT.** The weight of water displaced by any vessel.
- DOG.** A short iron bar, with a fang or teeth at one end, and a ring at the other. Used for a purchase, the fang being placed against a beam or knee, and the block of a tackle hooked to the ring.
- DOG-VANE.** A small vane, usually made of bunting, to show the direction of the wind.
- DOG-WATCHES.** Half watches of two hours each, from 4 to 6 and 6 to 8 P. M.
- DOLPHIN.** A rope or strap around a mast to support the pud-dening, where the lower yards rest in the slings. Also, a spar or buoy, to which vessels may bend their cables.
- DOLPHIN-STRIKER.** The martingale.
- DOUSE.** To lower suddenly.
- DOWNHAUL.** A rope used to haul down jibs, staysails, and stud-sails.
- DRAG.** A machine with a bag net, used for dragging on the bot-tom for anything lost. A sea anchor to keep the head of the vessel to the wind, in bad weather.
- DRAUGHT.** The depth of water which a vessel requires to float her.
- DRAW.** A sail draws when it is filled by the wind.
- DRIFTS.** Pieces in the sheer-draught where the rails are cut off.
- DRIVE.** To scud before a gale, or to drift in a current.
- DRIVER.** A spanker.
- DROP.** The depth of a sail, from head to foot, amidships.
- DRUM-HEAD.** The top of the capstan.
- DUB.** To reduce the end of a timber.
- DUCK.** A kind of cloth, lighter and finer than canvas; used for small sails.
- DUNNAGE.** Loose material, placed on the bottom of the hold, above the ballast, to stow cargo.
- EARING.** A rope attached to the cringle of a sail, by which it is bent or reefed.
- EBB.** The reflux of the tide.
- EDDY.** A circular motion in the water caused by the meeting of opposite currents.
- ELBOW.** Two crosses in a hawse.
- ENSIGN.** The flag carried by a ship as the insignia of her na-tionality.
- EQUINOX.** The time the sun crosses the equator.
- EVEN-KEEL.** The position of a vessel when she is so trimmed that she sits evenly upon the water, neither end being down more than the other.

- EUVROU.** A piece of wood, by which the legs of the crow-foot to an awning are extended.
- EYE.** The circular part of a shroud or stay, where it goes over a mast.
- Eye-bolt.** A long iron bar, having an eye at one end, driven through a vessel's deck or side into a timber or beam, with the eye remaining out, to hook a tackle to. If there is a ring through this eye, it is called a **ring-bolt**.
- An **Eye-splice** is a kind of splice made with the end of a rope.
- Eyelet-hole.** A hole made in a sail for cringle or roband to go through.
- The **Eyes of a vessel.** The extreme forward part.
- FACE-PIECES.** Pieces of wood wrought on the fore part of the knee of the head.
- FACING.** Letting one piece of timber into another with a rabbet.
- FAG.** A rope is fagged when the end is untwisted.
- FAIR-LEADER.** A strip of board or plank or metal, with holes in it, for running rigging to lead through. Also, a block or thimble used for the same purpose.
- FAKE.** One of the circles made in coiling a rope.
- FALL.** That part of a tackle to which the power is applied in hoisting.
- FALSE KEEL.** A supplementary keel, bolted to the main keel on the outside, to give a vessel more draught.
- FANCY-LINE.** A line rove through a block at the jaws of a gaff, used as a downhaul. Also, a line used for cross-hauling the lee topping-lift.
- FASHION-PIECES.** The aftermost timbers, forming the shape of the stern.
- FAST.** A rope by which a vessel is secured. There are **bow, breast, quarter, and stern fasts**.
- FATHOM.** Six feet.
- FEATHER.** To feather an oar in rowing, is to turn the blade horizontally with the top aft as it comes out of the water, so as not to take the wind or dip up water.
- FEATHER-EDGED.** Planks which have one edge thicker than another.
- FENDERS.** Pieces of rope or wood hung over the side of a vessel or boat, to protect it from chafing. The fenders of small boats and yachts are usually made of canvas and stuffed with cork.
- FID.** A block of wood or iron, placed through the hole in the heel of a mast, and resting on the trestle-trees of the mast below. This supports the mast. Also, a wooden pin, tapered, used in splicing rigging, etc.
- FIDDLE-BLOCK.** A long shell, with one sheave over the other, the lower smaller than the upper.
- FIFE-RAIL.** The rail around a mast.
- FIGURE-HEAD.** A carved head or full-length figure, over the cut-water.
- FISH.** To raise the flukes of an anchor upon the gunwale. Also, to strengthen a spar when sprung or weakened, by fastening on other pieces.
- FISH-DAVIT.** The davit used for fishing an anchor.
- FISH-HOOK.** A hook with a pennant, to the end of which the fish-tackle is hooked.
- FISH-TACKLE.** The tackle used for fishing an anchor.
- FLARE.** When a vessel's sides go out from the perpendicular. The opposite to **turnbling-in**.

- FLAT.** A sheet is said to be hauled flat, when it is hauled down close.
- Flat-aback,** when a sail is blown with its after surface toward the stern.
- FLAW.** A gust of wind.
- FLEET.** To come up on a tackle and draw the blocks apart, for another pull, after they have been hauled **two-blocks**.
Also, to shift the position of a block or fall, so as to haul to more advantage.
- FLEMISH-HORSE.** An additional foot-rope at the ends of top-sail yards.
- FLOOR.** The bottom of a vessel, on each side of the keelson.
- FLOOR TIMBERS.** Timbers of a vessel placed across the keel.
- FLOWING SHEET.** When a vessel has the wind free, and the sheets are eased off.
- FLUKES.** The broad triangular plates at the extremity of the arms of an anchor, terminating in a point called the **bill**.
- FLUSH.** Level with.
- FLY.** That part of a flag which extends from the Union to the extreme end.
- FOOT.** The lower end of a mast or sail.
- FOOT-ROPE.** A rope upon which to stand when reefing or furling sail.
- FOOT-WALING.** The inside planks or lining of a vessel, over the floor-timbers.
- FORE.** Used to distinguish the forward part of a vessel, or things forward of amidships: as **fore mast, fore hatch**. The opposite to **aft** or **after**.
- FORE-AND-AFT.** Lengthwise with the vessel. The opposite to **athwartships**.
- FORECASTLE.** That part of the upper deck forward of the fore-mast; or, forward of the after part of the fore channels. Also, the forward part of the vessel, under the deck, where the sailors live.
- FORE-FOOT.** A piece of timber at the forward extremity of the keel, upon which the lower end of the stem rests.
- FORE-LOCK.** A flat piece of iron, driven through the end of a bolt, to prevent its drawing.
- FORE MAST.** The forward mast of a vessel.
- FORE-REACH.** To shoot ahead, as when going in stays.
- FORE-RUNNER.** A piece of rag, terminating the stray-line of the log-line.
- FORGE.** To forge ahead, to shoot ahead; as, in coming to anchor, or when going in stays.
- FORWARD.** In front of.
- FOTHER OR FODDER.** To draw a sail, filled with oakum, under a vessel's bottom, to stop a leak.
- FOUL.** The opposite of clear.
- FOUL ANCHOR.** When the cable has a turn around the anchor.
- FOUL HAWSE.** When the two cables are crossed or twisted, beyond the stem.
- FOUNDER.** When a vessel fills with water and sinks.
- FOX.** Made by twisting together two or more ropeyarns.
A Spanish fox is made by untwisting a single yarn and laying it up the contrary way.
- FRAME.** Skeleton of a vessel.
- FRAP.** To pass ropes around a sail to keep it from blowing loose. Also, to draw ropes around a vessel which is weakened, to keep her together.

- FREE.** A vessel is going free, when she has a fair wind. A vessel is free, when the water has been pumped out of her.
- FREEBOARD.** That portion of a vessel out of water.
- FRESHEN.** To relieve a rope, by moving its place; as, to freshen the nip of a stay, is to shift it so as to prevent its chafing through. To freshen ballast, is to alter its position.
- FRENCH-FAKE.** To coil a rope with each fake outside of the other, beginning in the middle. If there are to be riding fakes, they begin outside and go in. This is a Flemish coil.
- FULL-AND-BY.** Sailing close-hauled on a wind. The order given to keep the sails full and at the same time close to the wind.
- FURL.** To roll a sail up snugly on a yard or boom, and secure it.
- FUTTOCK-PLATES.** Iron plates crossing the sides of the top-rim perpendicularly. The dead-eyes of the topmast rigging are fitted to their upper ends, and the futtock-shrouds to their lower ends.
- FUTTOCK-SHROUDS.** Short shrouds, leading from the lower ends of the futtock-plates to the bend around the lower mast, just below the top.
- FUTTOCK-STAFF.** A short piece of wood or iron, seized across the upper part of the rigging, to which the cat-harpin legs are secured.
- FUTTOCK-TIMBERS.** Timbers between the floor and naval timbers, and the top-timbers. There are two—the lower, which is over the floor, and the middle, which is over the naval timber. The naval timber is sometimes called the ground futtock.
- GAFF.** A spar, to which the head of a fore-and-aft sail is bent.
- GAFF-TOPSAIL.** A light sail set over a gaff, the foot being spread by it.
- GAGE.** The depth of water of a vessel. Also, the position as to another vessel, as having the weather or lee gage.
- GALLEY.** The place where the cooking is done.
- GALLOWS-BITTS.** A strong frame raised amidships, to support spare spars, etc.
- GAMMONING.** The lashing by which the bowsprit is secured to the cutwater.
- GANG CASKS.** Small casks, used for bringing water on board in boats.
- GANGWAY.** That part of a vessel's side, amidships, where people pass in and out of the vessel.
- GARBOARD-STREAK.** The planks next the keel, on each side.
- GARLAND.** A large rope, strap or grommet, lashed to a spar when hoisting it on board.
- GARNET.** A purchase on the mainstay, for hoisting.
- GASKETS.** Ropes or piece of canvas, used to secure a sail when it is furled.
- GEAR.** A general term, meaning rigging.
- GIG.** Usually understood as the officers' boat.
- GIMBLAS.** The brass ring in which a compass sets to keep it level.
- GIMBLET.** To turn an anchor around by its stock. To turn anything around on its end.
- GIRTLINE.** A rope rove through a single block aloft, making a whip purchase.
- GIVE WAY!** An order to men in a boat to pull with more force, or to begin pulling. The same as, Lay out on your oars! or Lay out!
- GOB-LINE or GAUB-LINE.** A rope leading from the martingale inboard. The same as back-rope.

- GOOSE-NECK.** An iron ring fitted to the end of a yard or boom.
- GORES.** The angles at one or both ends of cloths that increase the breadth or depth of a sail.
- GORING-CLOTHS.** Pieces cut obliquely and put in to add to the breadth of a sail.
- GRAFTING.** Covering a rope by weaving yarns together.
- GRAINS.** An iron with four or more barbed points, used for striking small fish.
- GRANNY KNOT.** A square knot improperly tied.
- GRAPNEL.** A small anchor with several claws.
- GRAPPLING IRONS.** Crooked irons, used to seize and hold vessels fast.
- GRATING.** Open lattice work of wood. Used principally to cover hatches in good weather; also to let in light and air.
- GREAVE.** To clean a ship's bottom by burning.
- GRIPE.** The outside timber of the fore-foot, under water, fastened to the lower stem-piece. A vessel **gripes** when she tends to come up into the wind.
- GRIPEs.** Bars of iron, with lanyards, rings, and clews, by which a boat is lashed to the ring-bolts of the deck. Those for a quarter-boat are made of long strips of canvas, going round her and set taut by a lanyard.
- GROMMET.** A ring formed of rope, by laying around a single strand.
- GROUND TACKLE.** General term for anchors, cables, warps, springs, etc., anything used in securing a vessel at anchor.
- GUN-TACKLE PURCHASE.** A purchase made by two single blocks.
- GUNWALE.** The upper rail of a boat or vessel.
- GUY.** A rope attached to anything to steady it, and bear it one way or another in hoisting.
- GYBE.** To change the position of the sails of a fore-and-aft vessel from one side to the other without going in stays.
- HAIL.** To speak or call to another vessel, or to men in a different part of the ship.
- HALYARDS.** Ropes or tackles used for hoisting and lowering yards, gaffs, and sails.
- HAMMOCK.** A piece of canvas, suspended by each end, in which seamen sleep.
- HAND.** To hand a sail is to furl it. **Bear-a-hand;** make haste. **Lend-a-hand;** assist. **Hand-over-hand:** hauling rapidly on a rope, by putting one hand before the other alternately.
- HAND-LEAD.** A small lead, used for sounding in rivers and harbors.
- HANDSOMELY.** Slowly, carefully. As "Lower handsomely!"
- HANDSPIKE.** A long wooden bar, used for heaving at the windlass.
- HANDY BILLY.** A watch-tackle.
- HANKS.** Rings or hoops of wood, rope, or iron, around a stay.
- HARPINGS.** The fore part of the wales, which encompass the bows of a vessel, and are fastened to the stem.
- HARPOON.** A spear used for striking whales and other fish.
- HATCH, or HATCHWAY.** An opening in the deck to afford a passage up and down. The coverings over these openings are called hatches.
- HATCH-BAR.** An iron bar going across the hatches to keep them down.
- HAUL.** Haul her wind, when a vessel comes up close upon the wind.

- HAWSE-HOLE.** The hole in the bows through which the anchor cable runs.
- HAWSE-PIECES.** Timbers through which the hawse-holes are cut.
- HAWSE-BLOCK.** A block of wood fitted into a hawse-hole when at sea.
- HAWSER.** A large rope used for various purposes, as warping, for a spring, etc.
- HAWSER-LAID, or CABLE-LAID** rope, is rope laid with nine strands against the sun.
- HAZE.** Punishing a man by keeping him unnecessarily at some disagreeable work.
- HEAD.** The work at the prow of a vessel. If it is a carved figure, it is called a **figure-head**; if simple carved work, bending over and out, a **billet-head**; and if bending in, like the head of a violin, a **fiddle-head**. Also, the upper end of a mast, called the **mast-head**.
- HEAD-SAILS.** All sails that set forward of the fore-mast.
- HEART.** A block of wood in the shape of a heart, for stays to reeve through.
- HEART-YARNS.** The centre yarns of a strand.
- HEAVE SHORT.** To heave in on the cable until the vessel is nearly over her anchor.
- HEAVE-TO.** To put a vessel in the position of lying-to.
- HEAVE IN STAYS.** To go about, tacking.
- HEAVER.** A short wooden bar, tapering at each end, used as a purchase.
- HEEL.** The after part of the keel. The lower end of the mast or boom. Also, the lower end of the stern-post. To **heel**, is to careen on one side.
- HEELING.** The square part of the lower end of a mast, through which the fid-hole is made.
- HELM.** The machinery by which a vessel is steered, including the rudder, tiller, wheel, etc.
- HELM-PORT.** The hole in the counter through which the rudder head passes.
- HIGH AND DRY.** The situation of a vessel when she is aground, above water mark.
- HITCH.** The manner of fastening ropes.
- HOG.** A flat, rough broom, used for scrubbing the bottom of a vessel.
- HOGGED.** A vessel when, by any strain, she droops at each end.
- HOLD.** The interior of a vessel, where the cargo is stowed.
- HOLD WATER.** To stop the progress of a boat by keeping the oar-blades in the water.
- HOLY-STONE.** A large stone, used for cleaning a ship's decks.
- HOME.** The sheets of a sail are said to be **home**, when the clews are hauled chock out to the sheave-holes. An anchor comes **home** when it is loosened from the ground and is hove in.
- HOOD.** A covering for a companion hatch, skylight, etc.
- HOOD-ENDS, or HOODING-ENDS.** The ends of the planks which fit into the rabbets of the stem or stern-post.
- HOOK-AND-BUTT.** The scarfing, or laying the ends of timbers over each other.
- HORNS.** The jaws and booms and gaffs. Also, the ends of cross-trees.
- HOUNDS.** Projections at the mast-head serving as shoulders for the trestle-trees to rest upon.

- HOUSE.** To house a mast, is to lower it about half its length, and secure it by lashing its heel to the mast below. To house a gun, is to run it in clear of the port and secure it.
- HOUSING, or HOUSE-LINE.** A small rope made of three small yarns, and used for seizings.
- HULL.** The body of a vessel.
- IRONS.** A ship is in irons, when, in tacking, she will not bear away one way or the other.
- JACK.** A common term for the jack-cross-trees.
- JACK-BLOCK.** A block used in sending topgallant masts up and down.
- JACK-CROSS-TREES.** Iron cross-trees at the head of the long topgallant masts.
- JACK-STAFF.** A short staff, raised at the bowsprit cap, upon which the Union Jack is hoisted.
- JACK-STAYS.** Ropes stretched taut along a yard to bend the head of the sail to. Also, long strips of wood or iron, used for the same purpose.
- JACK-SCREW.** A purchase, used for stowing cotton.
- JACOB'S LADDER.** A ladder made of rope, with wooden steps.
- JAWS.** The inner ends of booms or gaffs, hollowed to go around the mast.
- JEERS.** Tackles for hoisting the lower yards.
- JEWEL-BLOCKS.** Single blocks at the yard-arms, through which the studdingsail halyards lead.
- JIB.** A triangular sail set on a stay, forward. The Flying-jib sets outside of the jib.
- JIB-BOOM.** The boom, rigged out beyond the bowsprit, to which the tack of the jib is lashed.
- JIGGER.** A small tackle, used about decks or aloft.
- JOLLY-BOAT.** A small boat, usually hoisted at the stern, on coasting vessels.
- JURY-MAST.** A temporary mast, rigged at sea, in place of one lost.
- KECKLING.** Old rope wound around cables, to keep them from chafing.
- KEDGE.** A small anchor, used for warping. To kedge, is to warp a vessel ahead.
- KEEL.** The lowest and principal timber of a vessel, running fore-and-aft the entire length, and supporting the frame. It is composed of several pieces, placed lengthwise, scarfed and bolted together.
- KEEL-HAUL.** To haul a man under a vessel's bottom, by ropes at the yard-arms on each side. Formerly practised as a punishment in ships of war.
- KEELSON.** A timber placed over the keel on the floor-timbers, and running parallel with it.
- KENTLEDGE.** Pig-iron ballast, laid each side of the keelson.
- KEVEL, or CAVIL.** A piece of wood, bolted to a timber or stanchion, used for belaying ropes to.
- KEVEL-HEADS.** Timber-heads, used as kevels.
- KINK.** A twist in a rope.
- KNEES.** Crooked pieces of timber, having two arms, used to connect the beams of a vessel with her timbers.
- KNIGHT-HEADS.** The timbers next the stem on each side, and continued high enough to form a support for the bowsprit.
- KNITTLES, or NETTLES.** The halves of two adjoining yarns in a rope, twisted together, for pointing or grafting. Also, small line used for seizings and for hammock-clews.

- KNOT.** A division on the log-line, answering to a mile of distance. A nautical mile is 6,080 feet; a land mile is 5,280 feet.
- LABOR.** A vessel is said to labor when she rolls or pitches heavily.
- LACING.** Rope used to lash a sail to a spar, or a bonnet to a sail.
- LAND-FALL.** Making land. A good land-fall, is when a vessel makes the land as intended.
- LAND HO!** The cry used when land is first seen when coming from sea.
- LANYARDS.** Ropes rove through dead-eyes for setting up rigging. Also a rope made fast to anything to secure it.
- LARBOARD.** The old term for the port or left-hand side of a vessel.
- LATCHINGS.** Loops on the head rope of a bonnet, by which it is laced to the foot of the sail.
- LATITUDE.** Distance north or south of the equator.
- LAUNCH.** A large boat. The Long-boat.
- LAY.** To come or to go; as, Lay aloft! Lay forward! Lay aft! Also, the direction in which the strands of a rope are twisted; as, from left to right, or from right to left.
- LEACH LINE.** A rope used for hauling up the leach of a sail.
- LEAD.** A piece of lead, in the shape of a cone or pyramid, with a small hole at the base, and a line attached to the upper end, used for sounding. The hole in the base is greased so as to get at the formation of the bottom.
- LEADING-WIND.** A fair wind. Applied to a wind abeam or quartering.
- LEDGES.** Small pieces of timber placed athwart-ships under the decks, between the beams.
- LEE.** The side opposite to that from which the wind blows; if a vessel has the wind on her starboard side, that will be the weather, and the port will be the lee side.
- A lee shore is the shore upon which the wind is blowing.
- Under the lee of anything, is when you have that between you and the wind.
- By the lee. A vessel, going free, when she has fallen off so much as to bring the wind around her stern, and to take her sails aback on the other side.
- LEE-BOARD.** A board fitted to the lee side of flat-bottomed crafts, to prevent their drifting to leeward.
- LEEWAY.** What a vessel loses by drifting to leeward. When sailing close-hauled with all sail set, a vessel should make no leeway.
- LEECH, or LEACH.** The border or edge of a sail, at the sides.
- LEEWARD.** The lee side. In a direction opposite to that from which the wind blows, which is called windward. The opposite of lee is weather, and of leeward is windward.
- LIBERTY.** Leave to go ashore.
- LIE-TO,** is to stop the progress of a vessel at sea, either by counter-bracing the yards, or by reducing sail so that she will make little or no headway, but will merely come to and fall off by the counteraction of the sails and helm.
- LIFE-LINES.** Ropes carried along yards, booms, etc., or at any part of the vessel, to hold on by.
- LIFT.** A rope or tackle, going from the yard-arms to the mast-head, to support and move the yard. Also, a term applied to the sails when the wind strikes them on the leeches and raises them slightly.
- LIGHTER.** A craft, used in loading and unloading vessels.

- LIMBERS, or LIMBERHOLES.** Holes cut in the lower part of the floor-timbers, each side of the keel, so as to allow water to flow fore-and-aft. **Limber-boards** are placed over the limbers to keep dirt from choking the limber-holes, and are movable. **Limber-chain.** A chain or small wire-rope rove fore-and-aft through the limbers, to clear them if necessary. **Limber-streak.** The streak of foot-waling nearest the keelson.
- LIST.** The inclination of a vessel to one side; as, a list to port, or a list to starboard.
- LOCKER.** A chest or box, to stow things in. **Chain-locker.** Where the chain cables are kept. **Boatswain's locker.** Where tools and small stuff for working upon rigging are kept.
- LOG-BOOK.** A journal kept by the chief officer, in which the position of the vessel, winds, weather, courses, distances, and everything of importance that occurs, is noted down.
- LOG.** An instrument for determining the speed of a vessel.
- LONG BOAT.** The largest boat in a merchant vessel.
- LONGITUDE.** Distance east or west of meridian of Greenwich.
- LONG-TIMBERS.** Timbers in the cant-bodies, reaching from the dead-wood to the head of the second futtock.
- LOOF.** That part of a vessel where the planks begin to bend as they approach the stern.
- LOOM.** That part of an oar which is within the row-lock. Also, to appear above the surface of the water; to appear larger than natural, as in a fog.
- LUBBER.** A greenhorn aboard a ship.
Lubber Line, the fore-and-aft line of a compass.
- LUBBER'S HOLE.** A hole in the top, next the mast.
- LUFF.** To put the helm so as to bring the ship up nearer the wind.
Keep your luff! etc. Order to luff. Also, the round part of a vessel's bow. The forward leech of fore-and-aft sails.
- LUFF-TACKLE.** A purchase composed of a double and single block.
Luff-upon-luff. A luff-tackle applied to the fall of another.
- LUGGER.** A small vessel carrying lug-sails.
- LUG-SAIL.** A sail used in boats and small vessels, bent to a yard which hangs obliquely to the mast.
- LURCH.** The sudden rolling of a vessel to one side.
- MADE.** A made mast or block is one composed of different pieces. A ship's lower mast is usually a made spar, her top-mast is a whole spar.
- MAIN.** In all vessels it applies to the principal mast and sail.
- MALL, or MAUL.** A heavy iron hammer used in driving bolts.
- MALLET.** A small maul, made of wood; as, caulking-mallet; also, serving-mallet, used in putting service on a rope.
- MANILLA.** A fibre grown in the Philippines.
- MAN-ROPES.** Ropes used in going up and down a vessel's side.
- MARKS.** The markings of a lead line to show depths at a glance or by feeling.
- MARL.** To wind or twist a small line or rope around another.
- MARLINE.** Small two-stranded stuff, used for marling. A finer kind of spunyarn.
- MARLING-HITCH.** A hitch used in marling.
- MARLINGSPIKE.** An iron pin, sharpened at one end, and having a hole in the other for a lanyard.
- MARRY.** To join ropes together by a worming over both.

- MARTINGALE.** A short, perpendicular spar, under the bowsprit-end, used for guying the head-stays. Sometimes called a dolphin striker.
- MAST.** A spar set upright from the deck, to support rigging, yards, and sails.
- MASTER.** The commander of a vessel.
- MAT.** Made of strands of old rope, and used to prevent chafing.
- MATE.** An officer ranking next to the master.
- MATHEW WALKER.** A stopper knot which takes its name from the originator.
- MEND.** To mend service is to add more to it.
- MESHES.** The spaces between the lines of a netting.
- MESS.** Any number of men who eat or lodge together.
- MESSENGER.** A rope used for heaving in a cable by the capstan.
- MIDSHIPS.** The timbers at the broadest part of the vessel.
- MILE.** A nautical mile is 1-60 of a degree of latitude, generally 6,080 feet.
- MISS-STAYS.** To fail of going about from one tack to another.
- MIZZEN-MAST.** The aftermost mast of a ship. The spanker is sometimes called the mizzen.
- MONKEY BLOCK.** A small single block strapped with a swivel.
- MOON-SAIL.** A small sail sometimes carried in light winds, above a skysail.
- MOP.** A cloth broom used on board vessels.
- MOULDS.** The patterns by which the frames of a vessel are worked out.
- MOUSE.** To put turns of rope-yarn or spunyarn around the end of a hook and its standing part when it is hooked to anything, so as to prevent its slipping out.
- MOUSING.** A knot or puddening, made of yarns, and placed on the outside of a rope.
- MUFFLE.** Oars are muffled by putting mats or canvas around their looms in the row-locks.
- NAVIGATION.** The art of conducting a ship from port to port.
- NEAP TIDES.** Low tides, occurring at the middle of the moon's second and fourth quarters.
- NEAPED.** The situation of a vessel when she is aground at the height of the spring tides.
- NEAR.** Close to the wind.
- NETTING.** Network of rope or small lines. Used for stowing away sails or hammocks.
- NINEPIN BLOCK.** A block in the form of a ninepin, used for a fair-leader in the rail.
- NIP.** A short turn in a rope.
- NIPPERS.** A number of yarns mauled together, used to secure a cable to the messenger.
- NOCK.** The forward upper end of a sail that sets with a boom.
- NUN-BUOY.** A buoy tapering at each end.
- NUT.** Projections on each side of the shank of an anchor, to secure the stock to its place.
- OAKUM.** Stuff made by picking rope-yarns to pieces. Used for caulking, and other purposes.
- OAR.** A long wooden instrument with a flat blade at one end, used for propelling boats.
- OFF-AND-ON.** To stand on different tacks towards and from the land.
- OFFING.** Distance from the shore.
- OUT-HAUL.** A rope used for hauling out the clew of a sail.
- OUT-RIGGER.** A spar rigged out to windward from the tops or cross-trees, to spread the breast-backstays.

- OVERHAUL.** To overhaul a tackle, is to let go the fall and pull on the leading parts so as to separate the blocks. To overhaul a rope, is generally to pull a part through a block so as to make slack. To overhaul rigging, is to examine it.
- PAINTER.** A rope attached to the bows of a boat, used for making her fast.
- PALM.** A piece of leather fitted over the hand, with an iron for the head of a needle to press against in sewing canvas. Also, the fluke of an anchor.
- PARBUCKLE.** To hoist or lower a spar or cask by single ropes passed around it.
- PARCEL.** To wind tarred canvas around a rope (called parceling).
- PARRAL.** The rope by which a yard is confined to the mast at its centre.
- PART.** To break a rope or chain.
- PARTNERS.** A frame-work of short timber fitted to the hole in a deck to receive the lower end of a mast or pump, etc.
- PAZAREE.** A rope attached to the clew of the foresail and wove through a block on the swinging boom. Used for guying the clews out when before the wind.
- PAUNCH MAT.** A thick mat, placed at the slings of a yard or elsewhere.
- PAWL.** A short bar of iron, which prevents the capstan or windlass from turning back.
- PAY-OFF.** When a vessel's head falls off from the wind. To pay. To cover over with tar or pitch. To pay out. To slack up a cable or rope, and let it run out.
- PEAK.** The upper outer corner of a sail attached to a gaff.
- PENDANT OR PENNANT.** A long narrow piece of bunting, carried at the masthead. Broad pennant, is a square piece, carried in the same way, in a commodore's vessel. Pennant. A rope to which a purchase is hooked. A long strap fitted at one end to a yard or masthead, with a hook or block at the other end, for a brace to reeve through, or to hook a tackle to.
- PILLOW.** A block which supports the inner end of the bowsprit.
- PIN.** The axis on which a sheave turns. Also, a short piece of wood or iron to belay ropes to.
- PINK-STERN.** When a vessel has a high, narrow stern, pointed at the end.
- PINNACE.** A boat, in size between a launch and the cutter.
- PINTLE.** A metal bolt, used for hanging a rudder.
- PITCH.** A resin taken from pine, and used for filling up the seams of a vessel.
- PLANKS.** Thick, strong boards, used for covering the sides and decks of vessels.
- PLUG.** A piece of wood, fitted into a hole in a vessel or boat, so as to let in or keep out water.
- POINT.** To take the end of a rope and work it over with knittles.
- POLE.** Applied to the highest mast of a ship, as sky-sail pole.
- POOP.** A deck raised over the after part of the spar deck.
- POPPETS.** Perpendicular pieces of timber fixed to the fore-and-aft part of the bilge-ways when launching.
- PORT.** The left side of a vessel as you look forward.
- PORT OR PORT-HOLE.** Holes in the side of a vessel. Also, holes in the bow of a vessel by which to load and unload large timber, etc., too long to go through the hatches.
- PORTOISE.** The gunwale. The yards are a-portoise when they rest on the gunwale.

- PRAYER BOOK.** A small, flat holystone used in narrow places.
- PREVENTER.** An additional rope or spar, used as a support.
- PRICKER.** A small marling spike, used in sail-making, rigging, etc.
- PUDDENING.** A quantity of yarns, matting, or oakum, used to prevent chafing.
- PUMP-BRAKE.** The handle to the pump.
- PURCHASE.** A mechanical power which increases the force applied.
- QUADRANT.** An instrument used in navigation.
- QUARTER.** The part of a vessel's side between the after part of the main chains and the stern. The quarter of a yard is between the slings and the yard-arm.
- QUARTER-BLOCK.** A block fitted under the quarters of a yard on each side of the slings, for the clewlines and sheets to reeve through.
- QUARTER-DECK.** That part of the upper deck abaft the mainmast.
- QUARTER-MASTER.** A petty officer, who attends the helm and binnacle, watches for signals, etc.
- QUICK-WORK.** That part of a vessel's side which is above the chainwales and decks.
- QUILTING.** A coating about a vessel, outside, formed of ropes woven together.
- QUON.** A wooden wedge for the breach of a gun to rest upon.
- RABBET.** A groove to receive the edge of a plank in ship building.
- RACE.** A strong, rippling tide.
- RACK.** To seize two ropes together, with cross-turns. Also, a fair-leader for running rigging.
- RACK-BLOCK.** A course of blocks made from one piece of wood, for fair-leaders.
- RAKE.** The inclination of a mast from the perpendicular.
- RAMLINE.** A line used in mast-making to get a straight middle line on a spar.
- RANGE OF CABLE.** A quantity of cable, ready for letting go the anchor or paying out.
- RATLINES.** Lines running across the shrouds, horizontally, and used, in going aloft, as a ladder.
- RATTLE-DOWN RIGGING.** To put ratlines upon rigging. It is still called rattling down, though rigging is now rattled up, beginning at the lowest.
- RAZEE.** A vessel of war which has had one deck cut down.
- READY ABOUT.** The order to stand by to tack ship.
- REEF.** To reduce a sail by taking in upon its head, if a square sail, and its foot, if a fore-and-aft sail.
- REEF-BAND.** A band of stout canvas sewed on the sail across, with points in it, and earings at each end for reefing.
- REEF-TACKLE.** A tackle used on a square sail to haul the middle of each leech up toward the yard, so that the sail may be easily reefed. Also, on fore-and-aft vessels, to haul out the foot of the sail.
- REEVE.** To pass the end of a rope through a block, or an aperture.
- RELIEVING TACKLE.** A tackle hooked to the tiller, to steer by in case of accident to the wheel or tiller-ropes.
- RENDER.** To pass a rope through a place. A rope is said to render or not, as it goes freely.

- RIB-BANDS.** Long, narrow, flexible pieces of timber nailed to the outside of the ribs so as to encompass the vessel lengthwise.
- RIBS.** The timbers of a vessel.
- RIDE AT ANCHOR.** To lie at anchor. Also, to bend or bear down by main strength and weight.
- RIDERS.** Interior timbers placed occasionally opposite the principal ones, to which they are bolted, reaching from the keelson to the beams of the lower deck. Also, casks forming the second tier in a vessel's hold.
- RIGGING.** The general term for all the ropes of a vessel. Also, the common term for the shrouds with their ratlines; as, the main rigging, mizzen rigging, etc.
- RIGHT.** To right the helm, is to put it amidships.
- RING.** The iron ring at the upper end of an anchor, to which the cable is bent.
- RING-BOLT.** An eye-bolt with a ring through the eye.
- RING-TAIL.** A small sail, shaped like a jib, set abaft the spanker in light winds.
- ROACH.** A curve in the foot of a square sail, by which the clews are brought below the middle of the foot. The roach of a fore-and-aft sail is in its forward leech.
- ROAD, or ROADSTEAD.** An anchorage at a distance from the shore.
- ROLLING TACKLE.** Tackles used to steady the yards in a heavy sea. Also, used on smoke stacks of steamers to keep them steady.
- ROPE-YARN.** A thread of hemp, or other stuff, of which a rope is made.
- ROUGH-TREE.** An unfinished spar.
- ROUND IN.** To haul in on a rope.
- ROUND UP.** To haul up on a tackle.
- ROUNDING.** A service of rope, hove around a spar or larger rope.
- ROWLOCKS.** The receptacles for the oars in rowing.
- ROYAL.** A light sail next above a topgallant sail.
- ROYAL YARD.** The yard from which the royal is set. The fourth from the deck.
- RUBBER.** A small instrument used to rub or flatten down the seams of a sail in sail-making.
- RUDDER.** That by which a vessel or boat is steered, attached to the stern-post.
- RULES OF THE ROAD.** The international regulations for preventing collisions at sea.
- RUN.** The after part of a vessel's bottom, which rises and narrows in approaching the stern-post. **By the run.** To let go by the run, is to let go altogether, instead of gradually.
- RUNG-HEADS.** The upper ends of the floor-timbers.
- RUNNER.** A rope to increase the power of a tackle. It is rove through a single block, and a tackle is hooked to each end, or to one end, the other being fast.
- RUNNING RIGGING.** The ropes that reeve through blocks, and are pulled and hauled, such as braces, halyards, etc.; in contrast to the standing rigging, the ends of which are securely seized, such as stays, shrouds, etc.
- SADDLES.** Pieces of wood hollowed out to fit on the yards to which they are nailed, having a hollow in the upper part for the boom to rest in.
- SAG.** To sag to leeward, is to drift off bodily to leeward.

- SAILS** are of two kinds: square sails, which hang from yards, their foot lying across the line of the keel, as the courses, topsails, etc.; and fore-and-aft-sails, which set upon gaffs, booms, etc., their foot running with the line of the keel.
- SAIL HO!** The cry used when a sail is discovered at sea.
- SAVE-ALL.** A small sail sometimes set under the foot of a lower sail, often called a catch-all.
- SCANTLING.** A term applied to any piece of timber, with regard to its breadth and thickness, when reduced to the standard size.
- SCARF.** To join pieces of timber at their ends by shaving them down and over-lapping them.
- SCHOONER.** A vessel with two or more masts. A fore-and-aft schooner has only fore-and-aft sails. A topsail schooner carries a square fore topsail, and frequently, topgallant sail and royal schooners are now built with two, three, four, and many with five masts.
- SCORE.** A groove in a block or dead-eye.
- SCOTCHMAN.** A large batten placed over the turnings-in of rigging, to prevent chafing.
- SCRAPER.** A small, triangular iron instrument, with a handle fitted to its centre, used for scraping decks, masts, etc.
- SCROWL.** A piece of timber bolted to the knees of the head, in place of a figure-head.
- SCUD.** To drive before a gale, with no sail, or only enough to steady the vessel. Also, low, thin, clouds that fly swiftly before the wind.
- SCULL.** A short oar. To scull, is to impel a boat by one oar at the stern.
- SCUPPERS.** Holes cut in the water-ways for the water to run from the decks.
- SCUTTLE.** A hole cut in a vessel's deck, as, a hatchway. Also, a hole cut in any part of a vessel. To scuttle, is to cut or bore holes in a vessel to make her sink.
- SEAMS.** The intervals between planks in a vessel's deck or side.
- SEIZE.** To fasten ropes together by turns of small stuff, to secure hooks, etc.
- SEIZINGS.** The fastenings of ropes that are seized together.
- SELVAGEE.** A skein of rope-yarns or spunyarn, marled together. Used as a neat strap.
- SENNIT, or SINNIT.** A braid, formed by plaiting rope-yarns or spunyarn together.
- SERVE.** To wind small stuff, as rope-yarns, spunyarn, etc., around a rope, to keep it from chafing. It is wound and hove round taut by a serving-board or mallet.
- SET.** To set up rigging, is to tighten it.
- SEXTANT.** The instrument used in determining altitudes of heavenly bodies.
- SHACKLES.** Links in a chain cable fitted with a movable bolt so that the chain can be separated.
- SHANK.** The main piece is an anchor; the stock is made fast at one end, and the arms at the other.
- SHANK-PAINTER.** A strong rope by which the lower part of the shank of an anchor is secured to the ship's side.
- SHARP UP.** Yards when braced as near fore-and-aft as possible.
- SHEATHING.** A casing or covering on the bottom of a vessel.
- SHEARS.** Two or more spars, raised at angles and lashed together near their upper ends, used for lowering or hoisting heavy objects.

- SHEAR HULK.** An old vessel fitted with shears, etc., and used for taking out and putting in the spars of the other vessels.
- SHEAVE.** The wheel is a block upon which the rope runs. **Sheave-hole,** the place cut in a block for the ropes to reeve through.
- SHEEP-SHANK.** A hitch or bend, used to shorten a rope temporarily.
- SHEER, or SHEER-STRAKE.** The line of plank on a vessel's side, running fore-and-aft under the gunwale. Also, a vessel's position when riding by a single anchor.
- SHEETS.** Ropes used in working a sail, to keep the clew down to its place. With square sails, the sheets run through each yard-arm. With boom sails, they haul the sails to the desired positions.
- SHEET ANCHOR.** A vessel's largest anchor.
- SHELL.** The case of a block.
- SHIP.** A vessel with three or four masts, with tops and yards. To enter on board a vessel. To fix anything in its proper place, such as ship shape.
- SHIVER.** To shake the wind out of a sail by bracing it so that the wind strikes upon the leech.
- SHOE.** A piece of wood used for the bill of an anchor to rest upon. Also, for the heels of shears, etc. Also added to a vessel's keel to give her more draft.
- SHOE-BLOCK.** A block with two sheaves, one above the other, the one horizontal and the other perpendicular.
- SHORE.** A prop or stanchion, placed under a beam. To shore, to prop up.
- SHROUDS.** Ropes on each side of a vessel, reaching from the mast-heads to the vessel's sides, to support the masts.
- SILLS.** Pieces of timber put in horizontally between the frames to form and secure openings.
- SISTER BLOCK.** A long piece of wood with two sheaves in it, one above the other, with a score between them for a seizing, and a groove around the block, lengthwise. Two blocks of same size attached to a ring usually used for jib-halyards, etc.
- SKIN.** The part of a sail which is outside and covers the rest when it is furled. Also, the sides of the hold; as, an article is said to be stowed next to the skin.
- SKYSAIL.** A light sail next above the royal.
- SKY-SCRAPER.** A skysail when it is triangular.
- SLABLINE.** A small line used to haul up the foot of a course.
- SLACK.** The part of a rope or sail that hangs down loose. **Slack in stays,** is sail of a vessel when she works slowly in tacking.
- SLEEPERS.** The knees that connect the transoms to the after timbers on the ship's quarter.
- SLING.** To set in ropes, so as to put on a tackle to hoist or lower it.
- SLINGS.** The ropes used for securing the centre of a yard to the mast. Also, a large rope fitted so as to go around anything which is to be hoisted or lowered.
- SLIP.** To let go a cable and stand out to sea. To slip the anchor.
- SLIP-ROPE.** A rope bent to the cable outside the hawse-hole, and brought in on the weather quarter, when ready to slip the anchor.
- SLOPS.** A name given to ready-made clothing supplied by the captain.
- SLOOP.** A small vessel with one mast.

- SLOOP OF WAR.** A vessel of any rig, mounting between 18 and 32 guns.
- SMALL STUFFS.** Spun-yarn, marline, and the smallest kinds of rope, such as ratline, etc.
- SNAKE.** To pass small stuff across a seizing, with marling hitches at the outer turns.
- SNATCH-BLOCK.** A single block, with an opening in its side below the sheave, or at the bottom, to receive the bight of a rope.
- SNOTTER.** A rope going over a yard-arm, with an eye, to bend a tripping-line to in sending down topgallant and royal yards, and other spars.
- SNUB.** To check a rope suddenly.
- SNYING.** A curved plank edgewise, to work in the bows of a vessel.
- SO!** An order to stop hauling upon anything when it has come to its right position.
- SOLE.** A piece of timber fastened to the foot of the rudder, to make it level with the false keel.
- SOUND.** To get the depth of water by a lead and line. The pumps are sounded by an iron sounding rod, marked with a scale of feet and inches.
- SPAN.** A rope with both ends made fast, so a purchase can be hooked to its bight.
- SPANKER.** The after sail of a ship or bark.
- SPARS.** The general term for masts, yards, booms, gaffs, etc.
- SPEAKING TRUMPET.** A trumpet for conveying orders on board vessel.
- SPELL.** The common term for a portion of time given to any work. To spell, is to relieve another.
- SPENCER.** A fore-and-aft sail, set with a gaff and no boom, and hoisting from a small mast called a spencer-mast, just abaft the fore and main masts.
- SPILL.** To shake the wind out of a sail.
- SPILLING LINE.** A rope used for spilling a sail. Used in bad weather.
- SPLICE.** To join two ropes together by interweaving their strands.
- SPINNAKER.** A light sail of great spread used on yachts when running before the wind.
- SPIRIT COMPASS.** The modern style of compass.
- SPOON-DRIFT.** Water swept from the tops of the waves by the violence of the wind, and driven along before it, covering the surface of the sea.
- SPRAY.** An occasional sprinkling dashed from the top of a wave by the wind.
- SPRING.** To crack or split a mast. To spring a leak, is to begin to leak. To spring a luff, is to force a vessel close to the wind, in sailing.
- SPRING-STAY.** A preventer-stay, to assist the regular stay.
- SPRING TIDES.** The highest and lowest course of tides, occurring every new and full moon.
- SPRIT.** A small boom or gaff, used with sails in small boats. The lower end rests in a becket or snotter by the foot of the mast, and the other end spreads and raises the outer upper corner of the sail, crossing it diagonally. A sail so rigged is called a sprit-sail.
- SPRIT-SAIL-YARD.** A yard lashed across the bowsprit or knight-heads, and used to spread the guys of the jib and flying jib-boom.

- SPUNYARN.** A rope formed by twisting together two or three rope-yarns.
- SPURLING LINE.** A line communicating between the tiller and tell-tale.
- SPURS.** Pieces of timber fixed on the bilge-ways, their upper ends being bolted to the vessel's sides above the water. Also, curved pieces of timber, serving as half beams, to support the decks where the whole beams cannot be placed.
- SPUR-SHOES.** Large pieces of timber that come abaft the pump-well.
- SQUARE.** Yards are squared when they are horizontal and at right angles with the keel. Squaring by the lifts makes them horizontal; and by the braces, makes them at right angles with the vessel's line. To square a yard, means to bring it in square by the braces.
- SQUARE-SAIL.** A temporary sail, set at the fore-mast of a schooner or the mainmast of a sloop, when going before the wind.
- STAFF.** A pole or mast, used to hoist flags upon.
- STABILITY.** Stiffness of a vessel.
- STANCHIONS.** Upright posts of wood or iron, placed so as to support the beams of a vessel. Also, upright pieces of timber, placed at intervals along the sides of a vessel, to support the bulwarks and rail, reaching down to the bends, by the side of the timbers, to which they are bolted. Also, any fixed, upright support.
- STAND BY!** To be prepared to act at once.
- STANDING.** The standing part of a rope is that which is fast, the opposite to the hauling part. The standing part of a tackle is that part which is made fast to the blocks and between that and the next sheave, the opposite to the hauling and leading parts.
- STANDING RIGGING.** That part of a vessel's rigging which is made fast to the sides.
- STARBOARD.** The right side of a vessel, looking forward.
- STATION BILL.** A list showing the station of every man, in case of accident.
- STAY.** To tack a vessel, or put her about, so that the wind, from being on one side, is brought upon the other, around the vessel's head. To stay a mast, is to incline it forward or aft, or to one side or the other, by the stays and backstays. A mast is said to be stayed too much forward or aft, or too much to port, etc.
- STAYS.** Large ropes, used to support masts, and leading from the head of one mast down to another, or to some part of the vessel. Those which lead forward are called fore-and-aft stays; and those which lead down to the vessel's sides, back-stays.
- In stays or hove in stays, a vessel when she is staying, or going from one tack to the other.
- STEADY!** To keep the helm as it is.
- STEEERAGE.** That part of the between-decks which is just forward of the cabin.
- STEEVE.** A bowsprit steeves more or less, as it is raised more or less from the horizontal. The steeve is the angle it makes with the horizon. Also, a long, heavy spar, with a place to fit a block at one end, and used in stowing cargo, which need be stowed close.

- STEM.** A piece of timber reaching from the forward end of the keel, to which it is scarfed, up to the bowsprit and to which the two sides of the vessel are secured.
- STEP.** A block of wood secured to the keel, into which the heel of the mast is placed.
- STERN.** The after end of a vessel.
- STERN-BOARD.** The motion of a vessel when going stern foremost.
- STERN-FRAME.** The frame composed of the stern-post transom and the fashion-pieces.
- STERN-POST.** The aftermost timber in a vessel, reaching from the after end of the keel to the deck. The stem and stern-post are the two extremes of a vessel's frame. The rudder is attached to the stern-post.
- STERN-SHEETS.** The after part of a boat, abaft the rowers, where the passengers sit.
- STEVEDORE.** A man who loads and unloads cargoes of vessels.
- STIFF.** The quality of a vessel which enables her to carry a great deal of sail without lying over much on her side. The opposite to crank.
- STIRRUPS.** Ropes with thimbles at their ends, through which the foot-ropes are rove, and by which they are kept up towards the yards.
- STOCK.** A beam of wood or a bar of iron, secured to the upper end of the shank of an anchor, at right angles with the arms. An iron stock usually goes with a key, and unships.
- STOCKS.** The frame upon which a vessel is built.
- STOOLS.** Small channels for the dead-eyes of the backstays.
- STOPPER.** A stout rope with a knot at one end, and sometimes a hook at the other, used for various purposes about decks; as, making fast a cable, so as to overhaul.
- STOPPER BOLTS.** Ring-bolts to which the deck stoppers are secured.
- STOP.** A fastening of small stuff. Also, small projections on the outside of the checks of a lower mast, at the upper parts of the hounds.
- STOW.** To pack the cargo.
- STRAND.** A number of rope-yarns twisted together. Three, four, or nine strands twisted together form a rope. A rope is stranded when one of its strands is parted or broken. A vessel is stranded when she is driven on shore.
- STRAP.** Rope or iron around a block to keep its parts together.
- STREAK, or STRAKE.** Planks running fore and aft on the outside of a vessel.
- STREAM.** The stream anchor is one used for warping, etc., and sometimes as a lighter anchor to moor by, with a hawser. It is smaller than the bowers, and larger than the kedgers.
- STRETCHERS.** Pieces of wood placed across a boat's bottom, inside, for the oarsmen to press their feet against, when rowing. Also, cross pieces placed between a boat's sides to keep them apart when hoisted up and griped.
- STRIKE.** To lower sail or colors.
- STRIP.** To dismantle.
- STUDDINGSAILS.** Light sails set outside the square sails, on booms rigged out for that purpose. They are only carried with a fair wind and in moderate weather.
- SUED, or SEWED.** The condition of a ship when she is high and dry on shore.
- SUPPORTERS.** The knee-timbers under the cat-heads.
- SURF.** The breaking of the sea upon the shore.

- SURGE.** A large, swelling wave. To surge a rope or cable, is to slack it up suddenly where it renders around a pin, or around the windlass or capstan.
- SWAB.** A mop, formed of old rope, used for cleaning and drying decks.
- SWAY.** To hoist up.
- SWEEP.** To drag the bottom. Also, large oars, used in small vessels to force them ahead.
- SWIFT.** To bring two shrouds or stays close together by ropes.
- SWIFTER.** The forward shroud to a lower mast. Also, ropes used to confine the capstan bars to their places when shipped.
- SWIG.** The mode of hauling upon the bight of a rope when its lower end is fast.
- SWIVEL.** A long link of iron, used in chain cables, made so as to turn upon an axis intended to keep the turns out of a chain.
- SYPHERING.** Lapping the edges of planks over each other for a bulk-head.
- TABLING.** Letting one beam-piece into another. Also, the broad hem on the borders of sails, to which the bolt-rope is sewed.
- TACK.** To put a ship about, so that from having the wind on one side it is brought around on the other by the way of her head. The opposite of wearing.
- A vessel is on the starboard tack, or has her starboard tacks on board, when she has the wind on her starboard side.
- The rope or tackle by which the weather clew of a course is hauled forward and down.
- The tack of a fore-and-aft sail is the rope that keeps down the lower forward clew; and of a studdingsail, the lower outer clew. The tack of the lower studdingsail is called the outhaul. Also, that part of a sail to which the tack is attached.
- TACKLE.** A purchase; formed by a rope rove through one or more blocks.
- TAFFRAIL.** The rail around a ship's stern.
- TAIL.** A rope spliced into the end of a block and used for making it fast to rigging or spars is called a tail-block. A ship is said to tail up or down stream, when at anchor, according as her stern swings up or down with the tide; the opposite to heading one way or another.
- TAIL-TACKLE.** A watch-tackle.
- TAIL ON!** To take hold of a rope and pull.
- TAR.** A liquid gum, taken from pine and fir trees, and used for caulking, and to put upon yarns in rope-making, and upon standing rigging, to protect it from the weather.
- TARPAULIN.** A piece of canvas, covered with tar, used for covering hatches, boats, etc. Also, the name commonly given to a sailor's hat when made of tarred or painted cloth.
- TAUT.** Tight, snug.
- TELL-TALE.** A compass hanging from the beams of the cabin, by which the heading of a vessel may be known at any time. Also, an instrument connected with the steering apparatus, and traversing so that the position of the rudder can be determined.
- TEND.** To watch a vessel at anchor at the turn of tides, and cast her by the helm, and some sail, if necessary, so as to keep turns out of the cables.
- TENON.** The heel of a mast, made to fit into the step.
- THICK-AND-THIN BLOCK.** A block having one sheave larger than the other. Sometimes used for quarter-blocks.

- THIMBLE.** An iron ring, having its rim concave on the outside for a rope or strap to fit snugly.
- THOLE-PINS.** Pins in the gunwale of a boat, between which an oar is held when pulling.
- THROAT.** The inner end of a gaff, where it widens and hollows in to fit the mast. Also, the hollow part of a knee. The throat brails, halyards, etc., are those that hoist or haul up the gaff or sail near the throat. Also, the angle where the arm of an anchor is joined to the shank.
- THRUM.** To stick short strands of yarn through a mat or canvas, to make a rough surface.
- THWARTS.** The seats going across a boat, upon which the oarsmen sit.
- TIDE.** To tide up or down a river or harbor, is to work up or down with a fair tide and head wind or calm, coming to anchor when the tide turns.
- TIDE RODE.** When a vessel, at anchor, swings by the force of the tide. Opposite to wind-rode.
- TIER.** A range of casks. Also, the range of the fakes of a cable or hawser.
The cable tier is the place in a hold or between decks where the cables are stowed.
- TILLER.** A bar of wood or iron, put into the head of the rudder, by which it is moved.
- TIMBER.** A general term for all large pieces of wood used in ship-building. Also, more particularly, long pieces of wood in a curved form, bending outward, and running from the keel up, on each side, forming the ribs of a vessel. The keel, stem, stern-posts and timbers form a vessel's outer frame.
- TIMBER-HEADS.** The ends of the timbers that come above the deck. Used for belaying hawsers and large ropes.
- TOGGLE.** A pin placed through the bight or eye of a rope, block-strap, or bolt, to keep it in its place, or to put the bight or eye of another rope upon, securing them together.
- TOMPION.** A bung or plug placed in the mouth of a cannon.
- TOP.** A platform placed over the head of a lower mast, resting on the trestle-trees, to spread the rigging, and for the convenience of men aloft. To top up a yard or boom, is to raise up one end of it by hoisting on the lift.
- TOP-BLOCK.** A large iron-bound block, hooked into a bolt under the lower cap, and used for the top-rope to reeve through in sending up and down topmasts.
- TOP-LIGHT.** A signal lantern carried to the top.
- TOP-LINING.** Lining on the after part of sails, to prevent chafing against the top-rim.
- TOPMAST.** The second mast above the deck. Next above the lower mast.
- TOPGALLANT MAST.** The third mast above the deck.
- TOP-ROPE.** The rope used for sending topmasts up and down.
- TOPSAIL.** The second sail above the deck.
- TOPGALLANT SAIL.** The third sail above the deck.
- TOPPING LIFT.** A lift used for topping up the end of a boom.
- TOP-TIMBERS.** The highest timbers on a vessel's side, being above the futtocks.
- TOSS.** To throw an oar out of the rowlock, and raise it perpendicularly on its end, and lay it down in the boat, with its blade forward.

- TOUCH.** A sail is said to touch, when the wind strikes the leech so as to shake it a little.
Luff and touch her! To bring the vessel up and see how near she will go to the wind.
- TOW.** To draw a vessel along in the water.
- TRAIN-TACKLE.** The tackle used for running guns in and out.
- TRANSOMS.** Pieces of timber going across the stern-post, to which they are bolted. Raised platforms in small vessels and yachts, used for seats, etc.
- TRANSOM-KNEES.** Knees bolted to the transoms and after timbers.
- TRAVELLER.** An iron ring, fitted so as to slip up and down rigging.
- TREENAILS, or TRUNNELS.** Long wooden pins, used for nailing a plank to a timber.
- TREND.** The lower end of the shank of an anchor, being the same distance on the shank from the throat that the arm measures from the throat to the bill.
- TRESTLE-TREES.** Two strong pieces of timber, placed horizontally and fore-and-aft on opposite sides of a mast-head, to support the cross-trees and top, and for the fid of the mast above to rest upon.
- TRIATIC STAY.** A rope secured at each end to the heads of the fore and main masts, with thimbles spliced into its bight, to hook the stay tackles to.
- TRICE.** To haul up by means of a rope.
- TRICK.** The time allotted to a man to stand at the helm. A trick at the wheel.
- TRIM.** The condition of a vessel, with reference to her cargo and ballast. A vessel is trimmed by the head or by the stern. **In ballast trim,** is when she has only ballast on board. Also, to arrange the sails by the braces with reference to the wind.
- TRIP.** To raise an anchor clear of the bottom.
- TRIPPING LINE.** A line used for tripping a spar in sending it down.
- TRUCK.** A circular piece of wood, placed at the head of the masts of a vessel. It has small holes or sheaves in it for signal halyards to be rove through. Also, the wheel of a gun-carriage.
- TRUNNIONS.** The arms on each side of a cannon by which it rests upon the carriage, and on which, as an axis, it is elevated or depressed.
- TRUSS.** The rope by which the centre of a lower yard is kept in toward the mast.

- TRYSAIL.** A fore-and-aft sail, set with a boom and gaff, and noisting on a small mast abaft the lower mast, called a trysail-mast. This name is generally confined to the sail so carried at the mainmast of a full-rigged brig; those carried at the foremast and at the mainmast of a ship or bark being called spencers, and those that are at the mizzenmast of a ship or bark, spankers.
- TUMBLING HOME.** A ship's sides when they fall in above the bends. The opposite of wall-sided.
- TURK'S HEAD.** An ornamental knot.
- TURN.** Passing a rope around a pin or kevel, to keep it fast. Also, two crosses in a cable. To turn in or turn out, nautical terms for going to rest in a berth or hammock, and getting up. Turn up! The order given to send the men up from between decks.
- TYE.** A rope connected with a yard, to the other end of which a tackle is attached for hoisting.
- TYPHOON.** A hurricane in the Eastern seas.
- UNBEND.** To cast off or to untie.
- UNION.** The upper inner corner of an ensign. The rest of the flag is called the fly. The union of the U. S. ensign is a blue field with white stars, and the fly is composed of alternate white and red stripes.
- Union-down.** The situation of a flag when it is hoisted upside down, bringing the union down instead of up. Used as a signal of distress.
- Union-jack.** A small flag, containing only the union, without the fly, usually hoisted at the bowsprit-cap.
- UNMOOR.** To heave up one anchor so that the vessel may ride at a single anchor.
- VANE.** A fly at the mast-head, revolving on a spindle, to show the direction of the wind.
- VANG.** A rope leading from the peak of the gaff of a fore-and-aft sail to the rail on each side, used for steadying the gaff.
- VEER.** The wind when it changes. Also, to slack a cable and let it run out.
- To veer and haul, is to haul and slack alternately, until the vessel gets headway.
- VIOL.** A larger messenger sometimes used in weighing an anchor by a capstan. Also, the block through which the messenger passes.
- WAIST.** That part of the upper deck between the quarter-deck and forecastle.
- Waisters.** Green hands, or broken-down seamen, placed in the waist of a man-of-war.
- WAKE.** The track or path a vessel leaves behind her when sailing.
- WALES.** Strong planks in a vessel's sides, running her entire length fore-and-aft.
- WALL.** A knot put on the end of a rope.

- WALL-SIDED.** A vessel is wall-sided when her sides run up perpendicularly from the bends. The opposite to tumbling home or flaring out.
- WARD-ROOM.** The room in a vessel of war in which the commissioned officers live.
- WARE, or WEAR.** To turn a vessel around, so that, from having the wind on one side, the wind will be on the other side, carrying her stern around by the wind. In tacking, the same result is produced by carrying a vessel's head around by the wind.
- WARP.** To move a vessel from one place to another by means of a rope made fast to some fixed object, or to a kedge. A warp is a rope used for warping. If the warp is bent to a kedge which is let go, and the vessel is hove ahead by the capstan or windlass, it would be called kedging.
- WASH-BOARD.** Light pieces of board placed above the gunwale of a boat.
- WATCH.** A division of time on board ship. There are seven watches in a day, reckoning from 12 M. round through the 24 hours, five of them being of four hours each, and the two others, called dog watches, of two hours each, viz., from 4 to 6, and from 6 to 8 P. M. Also, a certain portion of a ship's company, appointed to stand a given length of time. In the merchant service all hands are divided into two watches, port and starboard, with a mate to command each. A buoy is said to watch when it floats on the surface.
- WATCH-AND-WATCH.** The arrangement by which the watches are alternated every other four hours. In distinction from keeping all hands during one or more watches.
- Anchor watch, a small watch of one or two men, kept while in port.
- WATCH HO! WATCH!** The cry of the man that heaves the deep-sea-lead.
- WATCH-TACKLE.** A small luff purchase with a short fall, the double block having a tail to it and the single one a hook. Used about deck.
- WATER SAIL.** A save-all, set under the swinging-boom.
- WATER-WAYS.** Long pieces of timber, running fore-and-aft on both sides, connecting the deck with the vessel's sides. The scuppers run through them to let the water off.
- WEATHER.** In the direction from which the wind blows.
- A ship carries a weather helm when she tends to come up into the wind.
- Weather gage.** A vessel has the weather gage of another when she is to windward of her.
- A weatherly ship, is one that works well to windward, making but little leeway.
- WEATHER-BITT.** To take an additional turn with a cable round the windlass-end.
- WEATHER ROLL.** The roll which a ship makes to windward.
- WEIGH.** To lift up, as, to weigh an anchor or a mast.
- WHEEL.** The instrument attached to the rudder by which a vessel is steered.

- WHIP.** A purchase formed by a rope rove through a single block. To whip, is to hoist by a whip. Also, to secure the end of a rope from fagging by seizing of twine. **Whip-upon-whip.** One whip applied to the fall of another.
- WHISKERS.** The cross-trees to a bowsprit.
- WINCH.** A purchase formed by a horizontal spindle or shaft with a wheel or crank at the end.
- WINDLASS.** The machine used to weigh the anchor by.
- WIND-RODE.** The situation of a vessel at anchor when she swings and rides by the force of the wind, instead of by the tide or current.
- WING.** That part of the hold or between-decks which is next the side.
- WINGERS.** Casks stowed in the wings of a vessel.
- WING-AND-WING.** The situation of a fore-and-aft vessel when she is going dead before the wind, with her foresail on one side and her mainsail on the other.
- WITHE, or WYTHE.** An iron band fitted on the end of a boom or mast, with a ring or eye to it, through which another boom or mast or rigging is made fast.
- WOOLD.** To wind a piece of rope around a spar.
- WORK UP.** To draw the yarns from old rigging and make them into spunyarn, foxes, sennit, etc. Also, a phrase for keeping a crew constantly at work upon the needless matters, and in all weathers, and beyond their usual hours, for punishment.
- WORM.** To fill up between the lays of a rope with small stuff wound around spirally. Stuff so wound round is called worming.
- WRING.** To bend or strain a mast by setting the rigging up too taut.
- WRING-BOLTS.** Bolts that secure the planks to the timbers.
- WRING-STAVES.** Strong pieces of plank used with the wring-bolts.
- YACHT.** A vessel of pleasure or state.
- YARD.** A long piece of timber, tapering slightly toward the ends, and hung by the centre to a mast, to spread the square sails upon.
- YARD-ARM.** The extremities of a yard.
- YARD-ARM AND YARD-ARM.** The situation of two vessels, lying alongside each other so that their yard-arms cross or touch.
- YAW.** The motion of a vessel when she goes off her course.
- YAWL.** A vessel with two masts, the small one aft.
- YELLOW FLAG.** Signifies vessels in quarantine.
- YEOMAN.** A man employed in a vessel of war to take charge of a store-room; as, boatswain's yeoman, the man that has charge of the stores, of rigging, etc.
- YOKE.** A piece of wood placed across the head of a boat's rudder with a rope attached to each end, by which the boat is steered.

SELF-EXAMINATION.

The following questions have been selected indiscriminately with the object of having the apprentice search for the answers, and it is hoped a keener interest will be developed and incidentally lead to discussions among the apprentices and instructors. If this is done, it will result in valuable information being derived from such discussions which will materially benefit all concerned.

If a doubt exists as to the meaning of any question, one of the officers of your ship will make the meaning clear if requested.

By close attention to the instructions he will receive, and by observing all the details of the ship, he should be able to answer most of these questions after his third week on the Training Ship.

Before completing the course of training an apprentice in the deck department will, upon submitting to the master, answers in writing to the questions on seamanship, be given credit for same upon his record card. An apprentice in the engine department submitting to the Chief Engineer, answers in writing to the questions on engineering, will likewise be given credit upon his record card.

No American boy should be willing to be classed as a "land lubber" when he is assigned to a merchant vessel; rather he should aim to carry on his work and execute all orders given him by the officers of his ship in a seamanlike manner. In this way only can rapid promotion be obtained.

QUESTIONS FOR SELF-EXAMINATION.

SEAMANSHIP.

1. How is a lead line marked?
2. How do you arm a lead?
3. How would you take a cast of the lead?
4. How are the soundings called off when reporting the cast?
5. What is a Patent Sounding Machine?
6. How do you use a Patent Sounding Machine?
7. What is a sea anchor?
8. For what purpose is a sea anchor used?
9. What is storm oil?
10. For what purpose is storm oil used?
11. What is a patent log?
12. How can you determine the speed of a ship by log?

13. What is a rotator?
14. How do you haul in a log line?
15. How are sea watches arranged?
16. How are the bells struck on ship board?
17. How do you box the compass?
18. What is the lubber line?
19. How should an officer be addressed?
20. How should an officer be answered when he gives an order?
21. What is the ceiling of a vessel?
22. What is the Plank Shear of a vessel?
23. What is the Shear Strake of a vessel?
24. What are cargo battens?
25. For what purpose are cargo battens used?
26. What is a Cargo Port?
27. What is an Air Port?
28. What is a Hawse Pipe?
29. What is a patent anchor?
30. What is meant by fishing the anchor?
31. What is a fish tackle?
32. How can you tell when a ship is moored with two anchors?
33. How can you tell when a ship is riding to two anchors?
34. How can you tell when a ship is hove short to her anchor?
35. What is the size of the anchor on your ship?
36. What is the length between shackles in a chain cable?
37. How are the shackles placed in a cable? That is to say, which parts go out through the hawse pipe first when the anchor is let go?
38. What are the sizes of the cables on your ship?
39. How do you determine the size of a cable?
40. What is the equipment of a life boat?
41. What is a fire drill on ship board?
42. What is a boat drill?
43. What is a cargo boom or derrick?
44. For what purpose is it used?
45. What is a cargo winch?
46. For what purpose is it used?
47. What is a windlass?
48. For what purpose is it used?
49. What is a capstan?
50. For what purpose is it used?
51. Which officer is on the forecastle deck when docking or undocking?
52. Which officer is aft when docking or undocking?
53. How can you tell the ship's draught?
54. What is meant by tacking ship?
55. When is a sailing vessel close hauled?
56. When is a sailing vessel running free?
57. What is meant by wearing ship?
58. What is meant when a vessel is said to miss-stay?
59. What is meant by heaving a ship to?
60. What is a belaying pin?
61. What is a gantline?
62. What is a Bo's'n Chair?
63. How do you bend on a flag?
64. What is the standing rigging of a ship?
65. What is the running rigging of a ship?
66. What is a tarpaulin?
67. For what purpose are tarpaulins used?
68. How do you overhaul a tackle?

69. How are the cargo booms or derricks stowed when a vessel is ready for sea?
70. What is a spring line?
71. What is a breast line?
72. What is a head line?
73. What is meant by heave away?
74. What is meant by avast heaving?
75. What is meant by pay out?
76. What is meant by slack away?
77. What is meant by belay?
78. What is a jib?
79. What is a stay sail?
 - a. What is a try sail?
 - b. What is a fore sail?
 - c. What is a main sail?
80. What are the duties of a lookout?
81. When an object is sighted, how should you report to the officer on the bridge?
82. On which side is the green light located?
83. On which side is the red light located?
84. Where are the range lights placed?
85. What does one blast of the whistle indicate?
 - a. What does two blasts of the whistle indicate?
 - b. What does three blasts of the whistle indicate?
 - c. What does several short blasts of the whistle indicate?

RULES OF THE ROAD.

- 1 What is a Vessel?
- 2 What is a Steam Vessel?
- 3 What is a Sailing Vessel?
- 4 When is a Vessel underway?
- 5 When is a Vessel termed to be a burdened vessel?
- 6 When is a Vessel termed to be a privileged vessel?
- 7 Which Vessel shall keep out of the way of the other?
- 8 When is one Vessel said to be overtaking another, and what are the respective duties of each vessel in this situation?
- 9 What is the starboard hand rule?
- 10 What is the narrow channel rule?
- 11 What lights are to be carried by a Steam Vessel underway?
- 12 What lights are to be carried by a Sailing Vessel underway?
- 13 Where should lights be carried?
- 14 What light should be exhibited on a Vessel at anchor?
- 15 Through how many points of the compass should the various lights show?
- 16 What are the lights required on a Towing Vessel?
- 17 What are the lights required on a Vessel being towed?
- 18 If you should see a flare-up light, what does that indicate?
- 19 If you should see two lights in a vertical line, one above the other, what does that indicate?
- 20 When has a Steam Vessel the right of way over a Sailing Vessel?
- 21 What are the signals used by Steam Vessels meeting and passing?
- 22 When is a towing steamer required to carry three Mast-headlights?

- 23 What light or lights are Pilot Vessels required to carry, when on station?
- 24 When is the danger of collision assumed to exist?
- 25 What is the fog signal of a Steam Vessel underway?
- 26 What is the fog signal of a Steam Vessel underway, but stopped?
- 27 What is the fog signal of a Steam Vessel, not under command?
- 28 What is the fog signal of a Towing Vessel?
- 29 What is the fog signal of a Vessel being towed?
- 30 What fog signals should be sounded by a Sailing Vessel—
- (a) On the starboard tack?
- (b) On the port tack?
- (c) With the wind abaft the beam?
- 31 What is the danger signal?
- 32 May cross signals ever be used?
- 33 What is the fog signal of a Vessel at anchor?
- 34 What signal is sounded by a Steam Vessel when going full speed astern?

ENGINEERING.

1. What are the duties of a coal-passer?
2. What are the duties of a fireman?
3. What are the duties of a water-tender?
4. What are the duties of an oiler?
5. Describe the construction of a Marine Scotch Boiler?
6. Describe the construction of a water tube boiler?
7. What is a screw stay?
8. What is a through stay?
9. Where is the combustion chamber located in a single end boiler?
10. In a double end boiler?
11. Where is the front tube sheet located?
12. Where is the back tube sheet located?
13. Where is the front head of the boiler located?
14. Where is the back head located?
15. Where is the Girth Seam located?
16. What tools are used by a fireman?
17. What is a steam drum?
18. Where is the wrapper sheet located?
19. What are fusible plugs; where are they located and for what purpose?
20. What is a butt strap and where located?
21. What is a safety valve?
22. For what purpose is it used?
23. What is a water gauge?
24. What are test cocks?
25. What would you do if the water went out of sight in the glass?
26. What is a steam gauge?
27. What is an injector?
28. For what purpose is it used?
29. What is a stop valve?

30. What is a check valve?
31. What is a Relief Valve?
32. What is an evaporator?
33. For what purpose is it used?
34. What is a condenser?
35. For what purpose is it used?
36. How many kinds of condensers are commonly used in Marine Practice?
37. What is a circulating pump?
38. What is an air pump?
39. How many kinds of engines are commonly used in Merchant Ships?
40. What is a reciprocating Engine?
41. What is a single Engine?
42. What is a compound Engine?
43. What is a triple expansion Engine?
44. What is a turbine Engine?
45. On what principle does the turbine operate?
46. What is an internal combustion Engine?
47. On what principle does it operate?
48. What is meant by the term "horse power"?
49. What is "indicated horse power"?
50. What is a Ballast Pump used for?
51. What is a Bilge Pump used for?
52. What is a crank web?
53. Where are the main bearings located?
54. What is a shaft coupling?
55. What is a Bull ring?
56. What is a packing ring?
57. Where are the guides located?
58. What are the Cross Head brasses?
59. Where are the Eccentric Rods located?
60. What is a settling tank used for?
61. What is a burner?
62. What is a Strainer?
63. What is a fuel oil pump used for?
64. What is a vent pipe?
65. What is the object of a vent pipe?
66. At what temperature does water boil at sea level?
67. What is the temperature in a boiler under 200-pound steam pressure?
68. What is a feed water heater?
69. For what purpose is it used?
70. What is a "superheater"?
71. For what purpose is it used?
72. Where is the "superheater" generally located?
73. What is the uptake?
74. Where is it located?
75. What is the ordinary working pressure of a Scotch boiler?
76. What is the working pressure of a water tube boiler?
77. What is meant by "forced draught"?
78. What is meant by "natural draught"?
79. What is the pitch of a propeller?
80. What is meant by "revolutions of the propeller"?
81. What is the slip of the propeller?
82. How is the propeller secured on the shaft?
83. What is the tail-end shaft?
84. What is meant by a right hand propeller?
85. What is meant by a left hand propeller?

James E. Thurgine
P.O. Lake Park, Havana Cuba
Sept 16th 1919

Chas. B. Brewster
Washington
10/1/1919

$$\begin{array}{r} 62 \\ 25 \\ \hline 87 \end{array}$$

62

